

# MARKS PUBLISHED FOR OPPOSITION

The following marks are published in compliance with section 12(a) of the Trademark Act of 1946. Applications for the registration of marks in more than one class have been filed as provided in section 30 of said act as amended by Public Law 772, 87th Congress, approved Oct. 9, 1962, 76 Stat. 769. Opposition under section 13 may be filed within thirty days of the date of this publication. See rules 2.101 to 2.105.

A separate fee of three hundred dollars (\$300.00) for opposing each mark in each class must accompany the opposition.

## SECTION 1.— INTERNATIONAL CLASSIFICATION

The short titles associated below with the international class numbers are terms designed merely for quick identification and are not an official part of the international classification. The full names of international classes are given in section 6.1 of the trademark rules of practice.

The designation "U.S. Cl." appearing in this section refers to the U.S. class in effect prior to Sep. 1, 1973 rather than the international class which applies to applications filed on or after that date. For adoption of international classification see notice in the OFFICIAL GAZETTE of Jun. 26, 1973 (911 O.G. TM 210).

### Application in more than one class

SN 76-696,891. CODEBLACK ENTERPRISES, LLC, UNIVERSAL CITY, CA. FILED 4-16-2009.

SN 76-698,372. CNL INCOME BRETTON WOODS, LLC, ORLANDO, FL. FILED 7-13-2009.

## WHY WE LAUGH

THE MARK CONSISTS OF STANDARD CHARACTERS WITHOUT CLAIM TO ANY PARTICULAR FONT, STYLE, SIZE, OR COLOR.

### CLASS 9—ELECTRICAL AND SCIENTIFIC APPARATUS

FOR COMPACT DISCS AND AUDIO VISUAL DEVICES, NAMELY, DVDS, VIDEO RECORDINGS, AUDIO RECORDINGS AND DOWNLOADABLE MP3, AUDIO AND DIGITAL FILES ALL FEATURING DOCUMENTARIES IN THE FIELD OF DRAMATIC AND ACTION SERIES, COMEDY, SPORTS, NEWS, URBAN AFFAIRS, WORLD AFFAIRS AND NEWS RELATED WORKS; AND MUSICAL SOUND RECORDINGS; AND MOTION PICTURE FILMS (U.S. CLS. 21, 23, 26, 36 AND 38).

### CLASS 16—PAPER GOODS AND PRINTED MATTER

FOR BOOKS IN THE FIELD OF ENTERTAINMENT, COMEDY, HISTORY, WORLD, AMERICAN, AFRICAN AMERICAN AND URBAN AFFAIRS (U.S. CLS. 2, 5, 22, 23, 29, 37, 38 AND 50).

### CLASS 25—CLOTHING

FOR CLOTHING, NAMELY, TEE SHIRTS, SWEAT PANTS, SWEAT SHIRTS, HATS, WRIST BANDS, SOCKS, SLEEPWEAR AND SHOES (U.S. CLS. 22 AND 39).

### CLASS 41—EDUCATION AND ENTERTAINMENT

FOR ENTERTAINMENT IN THE NATURE OF ONGOING TELEVISION PROGRAMS FEATURING DRAMATIC, ACTION, COMEDIC, SPORTS, URBAN AFFAIRS, WORLD AFFAIRS AND NEWS RELATED WORKS, LIVE PERFORMANCES BY RECORDING, FILM AND STAGE ARTISTS AND SPECIAL EVENTS (U.S. CLS. 100, 101 AND 107).  
KIMBERLY PERRY, EXAMINING ATTORNEY

## BRETTON WOODS

THE MARK CONSISTS OF STANDARD CHARACTERS WITHOUT CLAIM TO ANY PARTICULAR FONT, STYLE, SIZE, OR COLOR.  
OWNER OF U.S. REG. NOS. 3,610,771 AND 3,641,596.  
SEC. 2(F).

### CLASS 35—ADVERTISING AND BUSINESS

FOR PROVIDING FACILITIES FOR BUSINESS MEETINGS AND CONFERENCES (U.S. CLS. 100, 101 AND 102).  
FIRST USE 12-31-2003; IN COMMERCE 12-31-2003.

### CLASS 36—INSURANCE AND FINANCIAL

FOR RENTAL AND MANAGEMENT OF VACATION HOMES AND CONDOMINIUMS (U.S. CLS. 100, 101 AND 102).  
FIRST USE 12-31-2003; IN COMMERCE 12-31-2003.  
JEFFREY LOOK, EXAMINING ATTORNEY

SN 76-701,404. KAISER, MANSUR, RICHARDSON, TX. FILED 1-29-2010.

## COLONEL KABABZ

### CLASS 29—MEATS AND PROCESSED FOODS

FOR PREPARED ENTREES CONSISTING PRIMARILY OF MEAT, FISH, POULTRY OR VEGETABLES (U.S. CL. 46).  
FIRST USE 11-0-2009; IN COMMERCE 11-0-2009.

**CLASS 43—HOTEL AND RESTAURANT SERVICES**

FOR RESTAURANT SERVICES (U.S. CLS. 100 AND 101).

FIRST USE 11-0-2009; IN COMMERCE 11-0-2009.  
GINA HAYES, EXAMINING ATTORNEY

SN 77-034,294. DESIGN CONTINUUM, INC., WEST NEWTON, MA. FILED 11-1-2006.

**CONTINUUM** 

OWNER OF U.S. REG. NO. 2,088,946.  
THE MARK CONSISTS OF THE WORD "CONTINUUM" NEXT TO THE LETTER "U" UNDERLINED AND IN A CIRCLE.

SN 77-029,980. TWENTY FIRST CENTURY COMMUNICATIONS, INC., COLUMBUS, OH. FILED 10-26-2006.



NO CLAIM IS MADE TO THE EXCLUSIVE RIGHT TO USE "COMMUNICATIONS", APART FROM THE MARK AS SHOWN.

**CLASS 35—ADVERTISING AND BUSINESS**

FOR CORPORATE IDENTITY DESIGN SERVICES (U.S. CLS. 100, 101 AND 102).

FIRST USE 9-30-1995; IN COMMERCE 9-30-1995.

**CLASS 42—SCIENTIFIC AND COMPUTER SERVICES**

FOR ENGINEERING SERVICES, NAMELY, PRODUCT ENGINEERING SERVICES; DESIGN SERVICES FOR OTHERS, NAMELY, NEW PRODUCT DESIGN AND DEVELOPMENT SERVICES FOR OTHERS; INDUSTRIAL DESIGN SERVICES, GRAPHIC DESIGN SERVICES, WEBSITE DESIGN SERVICES, PACKAGING DESIGN SERVICES FOR OTHERS; STRATEGIC PRODUCT PLANNING SERVICES, NAMELY, PRODUCT RESEARCH; PRODUCT DEVELOPMENT FOR OTHERS; PRODUCT DEVELOPMENT CONSULTATION (U.S. CLS. 100 AND 101).

FIRST USE 9-30-1995; IN COMMERCE 9-30-1995.  
MARTHA FROMM, EXAMINING ATTORNEY

**CLASS 35—ADVERTISING AND BUSINESS**

FOR DATABASE MANAGEMENT SERVICES, NAMELY, COMPILATION, VERIFICATION, UPDATING AND CLEANSING OF DATABASES CONTAINING CUSTOMER CONTACT INFORMATION FOR OTHERS IN THE FIELD OF COMMUNICATIONS DURING EMERGENCY SITUATIONS (U.S. CLS. 100, 101 AND 102).

FIRST USE 11-1-2004; IN COMMERCE 11-1-2004.

SN 77-034,301. DESIGN CONTINUUM, INC., WEST NEWTON, MA. FILED 11-1-2006.

**CLASS 38—COMMUNICATION**

FOR HIGH VOLUME TELEPHONE COMMUNICATIONS SERVICES FOR PUBLIC UTILITIES, BUSINESSES AND GOVERNMENT AGENCIES, AND PROVIDING TELEPHONE COMMUNICATIONS SERVICES DESIGNED FOR USE DURING EMERGENCY SITUATIONS; COMMUNICATION SERVICES, NAMELY, TELEPHONE COMMUNICATION SERVICES FOR REPORTING AND UPDATING THE STATUS OF TROUBLE TICKETS FOR UTILITY COMPANIES; INTERNET COMMUNICATION SERVICES, NAMELY, PROVIDING VOICE COMMUNICATIONS SERVICES VIA THE INTERNET FOR REPORTING AND UPDATING THE STATUS OF TROUBLE TICKETS FOR UTILITY COMPANIES; TELEPHONE COMMUNICATION SERVICES, NAMELY, HANDLING CUSTOMER COMPLAINTS AND QUESTIONS DURING DISASTERS AND REPORTING OUTAGES TO UTILITIES (U.S. CLS. 100, 101 AND 104).

FIRST USE 11-1-2004; IN COMMERCE 11-1-2004.

**CONTINUUM**

THE MARK CONSISTS OF STANDARD CHARACTERS WITHOUT CLAIM TO ANY PARTICULAR FONT, STYLE, SIZE, OR COLOR.

**CLASS 42—SCIENTIFIC AND COMPUTER SERVICES**

FOR COMPUTER SERVICES, NAMELY, ACTING AS AN APPLICATION SERVICE PROVIDER IN THE FIELD OF KNOWLEDGE MANAGEMENT TO HOST COMPUTER APPLICATION SOFTWARE FOR SEARCHING AND RETRIEVING INFORMATION FROM DATABASES AND COMPUTER NETWORKS IN THE FIELD OF COMMUNICATIONS DURING EMERGENCY SITUATIONS (U.S. CLS. 100 AND 101).

FIRST USE 11-1-2004; IN COMMERCE 11-1-2004.  
ALLISON HOLTZ, EXAMINING ATTORNEY

**CLASS 35—ADVERTISING AND BUSINESS**

FOR CORPORATE IDENTITY DESIGN SERVICES (U.S. CLS. 100, 101 AND 102).

FIRST USE 9-30-1995; IN COMMERCE 9-30-1995.

**CLASS 42—SCIENTIFIC AND COMPUTER SERVICES**

FOR ENGINEERING SERVICES, NAMELY, PRODUCT ENGINEERING SERVICES; DESIGN SERVICES FOR OTHERS, NAMELY, NEW PRODUCT DESIGN AND DEVELOPMENT SERVICES FOR OTHERS; INDUSTRIAL DESIGN SERVICES, GRAPHIC DESIGN SERVICES, WEBSITE DESIGN SERVICES, PACKAGING DESIGN SERVICES FOR OTHERS; STRATEGIC PRODUCT PLANNING SERVICES, NAMELY, PRODUCT RESEARCH; PRODUCT DEVELOPMENT FOR OTHERS; PRODUCT DEVELOPMENT CONSULTATION (U.S. CLS. 100 AND 101).

FIRST USE 9-30-1995; IN COMMERCE 9-30-1995.  
MARTHA FROMM, EXAMINING ATTORNEY

SN 77-107,675. ANDREW J. TOBIAS, SANTA BARBARA, CA.  
FILED 2-14-2007.

# Music Mogul

THE MARK CONSISTS OF STANDARD CHARACTERS WITHOUT CLAIM TO ANY PARTICULAR FONT, STYLE, SIZE, OR COLOR.

OWNER OF U.S. REG. NO. 3,006,118.

## CLASS 9—ELECTRICAL AND SCIENTIFIC APPARATUS

FOR COMPUTER GAME CARTRIDGES; COMPUTER GAME DISCS; COMPUTER GAME PROGRAMS; COMPUTER GAME SOFTWARE; GAME SOFTWARE; INTERACTIVE VIDEO GAME PROGRAMS; VIDEO GAME CARTRIDGES; VIDEO GAME MACHINES FOR USE WITH EXTERNAL DISPLAY SCREEN OR MONITOR; VIDEO GAME SOFTWARE; VIDEO OUTPUT GAME MACHINES FOR USE WITH TELEVISIONS; VIRTUAL REALITY GAME SOFTWARE (U.S. CLS. 21, 23, 26, 36 AND 38).

## CLASS 28—TOYS AND SPORTING GOODS

FOR BOARD GAMES; CARD GAMES; HAND HELD UNIT FOR PLAYING ELECTRONIC GAMES; HAND HELD UNIT FOR PLAYING VIDEO GAMES; HAND-HELD GAMES WITH LIQUID CRYSTAL DISPLAYS (U.S. CLS. 22, 23, 38 AND 50).

## CLASS 41—EDUCATION AND ENTERTAINMENT

FOR ENTERTAINMENT SERVICES, NAMELY, PRODUCTION AND DISTRIBUTION OF A GAME SHOW; ENTERTAINMENT SERVICES, NAMELY, PROVIDING AN ON-LINE COMPUTER GAME; TELEVISION SHOW PRODUCTION (U.S. CLS. 100, 101 AND 107).

ERNEST SHOSHO, EXAMINING ATTORNEY

SN 77-218,225. RWACHSBERG HOLDINGS INC., CONCORD, CANADA, FILED 6-28-2007.

# GREEN SPIRIT

THE MARK CONSISTS OF STANDARD CHARACTERS WITHOUT CLAIM TO ANY PARTICULAR FONT, STYLE, SIZE, OR COLOR.

PRIORITY CLAIMED UNDER SEC. 44(D) ON CANADA APPLICATION NO. 1353651, FILED 6-28-2007, REG. NO. TMA745,929, DATED 8-21-2009, EXPIRES 8-21-2024.

OWNER OF CANADA REG. NO. TMA747,640, DATED 9-15-2009, EXPIRES 9-15-2024.

NO CLAIM IS MADE TO THE EXCLUSIVE RIGHT TO USE "GREEN", APART FROM THE MARK AS SHOWN.

## CLASS 1—CHEMICALS

FOR (BASED ON 44(E)) AROMATIC SOLVENTS FOR INDUSTRIAL AND COMMERCIAL USE; CHEMICAL PREPARATIONS FOR REMOVING DEPOSITS OF BICARBONATES, CARBONATES AND HYDROXIDES OF CALCIUM, MAGNESIUM AND IRON FROM CERAMIC, METAL, PORCELAIN, CEMENT, BRICK, CHROME AND STEEL SURFACES; ALL OF THE AFOREMENTIONED GOODS BEING ENVIRONMENTALLY FRIENDLY (U.S. CLS. 1, 5, 6, 10, 26 AND 46).

## CLASS 3—COSMETICS AND CLEANING PREPARATIONS

FOR (BASED ON 44(E)) NON-MEDICATED PERSONAL CARE PRODUCTS, NAMELY, SHAMPOOS AND HAIR CONDITIONERS, SKIN MOISTURIZERS, SKIN LOTION, BODY LOTION, BODY CREAM, SKIN CREAM, ANTI-AGING CREAM, NON-MEDICATED STRETCH MARK SKIN CREAMS, NON-MEDICATED COSMETIC LOTIONS AND CREAMS FOR HANDS, NAILS, SKIN, FACE, HAIR, AND VARICOSE VEINS; DEPILATORY LOTIONS AND CREAMS, SHAVING LOTIONS AND CREAMS, NON-MEDICATED SKIN CARE PREPARATIONS, NAMELY, ANTI-WRINKLE LOTIONS AND CREAMS, AND LOTIONS AND CREAMS FOR TREATING DRY AND DAMAGED SKIN, FOR ANTI-AGING, FOR SKIN FIRING, FOR STRETCH MARKS, AND UNDER EYE AND EYELID FIRING; NON-MEDICATED SKIN CARE PREPARATIONS IN GEL FORM, NAMELY, DEPILATORY GELS, SHAVING GELS, SHOWER GELS, MOISTURIZING AND ANTI-AGING GELS, AND STRETCH MARK GELS; OILS, NAMELY, BATH OILS, BODY OILS, COSMETIC OILS, AND NUTRITIONAL OILS FOR COSMETIC PURPOSES, NON-MEDICATED SKIN AND BEAUTY SERUMS, PETROLEUM JELLY FOR COSMETIC PURPOSES, SOAPS, LIQUID SOAPS, BAR SOAPS, ANTI-BACTERIAL LIQUID SOAPS, ANTI-BACTERIAL BAR SOAPS, HUMAN BODY SPRAYS, REFRESHING BODY SPRAYS, BODY WASHING SOAPS, BUBBLE BATH, BODY AND FACIAL SCRUBS, MASKS, NAMELY, BEAUTY MASKS, FACIAL MASKS, BODY MASKS, GEL EYE MASKS, SKIN MASKS, AND SKIN MOISTURIZER MASKS, NON-MEDICATED SKIN CARE PREPARATIONS IN THE NATURE OF FACE PEELS, NON-MEDICATED SKIN CARE PREPARATIONS, AND WRINKLE REMOVING SKIN CARE PREPARATIONS, COSMETIC SUN PROTECTION CREAMS AND LOTIONS, SUN CREAMS, AFTER-SUN LOTIONS WITH OR WITHOUT SPF, SUN BLOCK, SELF-TANNING CREAMS AND LOTIONS, TALCUM POWDERS; PERSONAL DEODORANTS, ALL PURPOSE CLEANERS, FLOOR CLEANING PREPARATIONS, GLASS CLEANERS, LAUNDRY BLEACH, FABRIC SOFTENER, LAUNDRY DETERGENTS, DETERGENT SOAPS, DISH DETERGENTS, HAND SOAPS, ANTI-BACTERIAL SOAPS, DEODORIZERS FOR PETS, IMPREGNATED CLEANING CLOTHS, DISPOSABLE WIPES IN SHEET FORM IMPREGNATED WITH CHEMICALS OR COMPOUNDS FOR USE ON HUMAN SKIN AND HOUSEHOLD, INDUSTRIAL, AND COMMERCIAL SURFACES, PRE-MOISTENED COSMETIC WIPES IN SHEET FORM, PRE-MOISTENED COSMETIC TOWELETES, AND PRE-MOISTENED TOWELETES IMPREGNATED WITH DISHWASHING DETERGENT; NON-MEDICATED SKIN CARE PREPARATIONS FOR ANTI-AGING, ANTI-WRINKLES, SKIN CONDITIONING AND SKIN FIRING, NAMELY, DAYTIME AND NIGHTTIME PILLS, CAPSULES, GEL CAPS AND TABLETS; HOUSEHOLD DEODORANTS; ALL OF THE AFOREMENTIONED GOODS BEING ENVIRONMENTALLY FRIENDLY (U.S. CLS. 1, 4, 6, 50, 51 AND 52).

## CLASS 4—LUBRICANTS AND FUELS

FOR (BASED ON 44(E)) ALL PURPOSE LUBRICANTS FOR HOUSEHOLD USE; ALL OF THE AFOREMENTIONED GOODS BEING ENVIRONMENTALLY FRIENDLY (U.S. CLS. 1, 6 AND 15).

**CLASS 5—PHARMACEUTICALS**

FOR (BASED ON INTENT TO USE) BARS FOR HUMAN CONSUMPTION, NAMELY, MEAL REPLACEMENT BARS, VITAMINS AND MINERALS FORMED AND PACKAGED AS BARS; POWDERS FOR HUMAN CONSUMPTION, NAMELY, POWDERED NUTRITIONAL SUPPLEMENT DRINK MIXES, MEAL REPLACEMENT POWDERS; SHAKES FOR HUMAN CONSUMPTION, NAMELY, MEAL REPLACEMENT SHAKES, VITAMINS FOR HUMAN CONSUMPTION, NUTRITIONAL SUPPLEMENTS FOR HUMAN CONSUMPTION FOR ANTI-AGING, ANTI-WRINKLES, SKIN CONDITIONING, SKIN FIRMLING, WEIGHT LOSS AND WEIGHT MAINTENANCE, NAMELY, CAPSULES, GEL CAPS AND TABLETS; DIETARY SUPPLEMENTS FOR HUMAN CONSUMPTION FOR ANTI-AGING, ANTI-WRINKLES, SKIN CONDITIONING, SKIN FIRMLING, WEIGHT LOSS AND WEIGHT MAINTENANCE, NAMELY, PILLS, CAPSULES, GEL CAPS AND TABLETS; AND MEDICATED SKIN CARE PREPARATIONS FOR ANTI-AGING, ANTI-WRINKLES, SKIN CONDITIONING AND SKIN FIRMLING, NAMELY, DAYTIME AND NIGHTTIME PILLS, CAPSULES, GEL CAPS AND TABLETS; (BASED ON 44(E)) HOUSEHOLD DEODORANTS; ANTIBACTERIAL CLEANERS, ANTI-MICROBIAL HANDWASH, ALL PURPOSE DISINFECTANTS, AIR, CAR AND CARPET DEODORIZERS, ROOM FRESHENER IN SPRAY FORM, AND MEDICATED PRE-MOISTENED TOWELETTES; MEDICATED LOTIONS AND CREAMS FOR VARICOSE VEINS AND FOOT AND LEG MUSCLE AND JOINT PAIN; ANTIBACTERIAL ALCOHOL SKIN SANITIZER GEL; ALL OF THE AFOREMENTIONED GOODS BEING ENVIRONMENTALLY FRIENDLY (U.S. CLS. 6, 18, 44, 46, 51 AND 52).

**CLASS 21—HOUSEWARES AND GLASS**

FOR (BASED ON 44(E)) CLEANING CLOTHS, PRE-MOISTENED TOWELETTES AND SPONGES FOR HOUSEHOLD CLEANING PURPOSES; ALL OF THE AFOREMENTIONED GOODS BEING ENVIRONMENTALLY FRIENDLY (U.S. CLS. 2, 13, 23, 29, 30, 33, 40 AND 50).

ZHALEH DELANEY, EXAMINING ATTORNEY

SN 77-218,227. RWACHSBERG HOLDINGS INC., CONCORD, CANADA, FILED 6-28-2007.

**GREEN PLANET**

THE MARK CONSISTS OF STANDARD CHARACTERS WITHOUT CLAIM TO ANY PARTICULAR FONT, STYLE, SIZE, OR COLOR.

PRIORITY CLAIMED UNDER SEC. 44(D) ON CANADA APPLICATION NO. 1353647, FILED 6-28-2007, REG. NO. TMA745,925, DATED 8-21-2009, EXPIRES 8-21-2024.

OWNER OF CANADA REG. NO. TMA747,647, DATED 9-15-2009, EXPIRES 9-15-2024.

NO CLAIM IS MADE TO THE EXCLUSIVE RIGHT TO USE "GREEN", APART FROM THE MARK AS SHOWN.

**CLASS 1—CHEMICALS**

FOR (BASED ON 44(E)) AROMATIC SOLVENTS FOR INDUSTRIAL AND COMMERCIAL USE; CHEMICAL PREPARATIONS FOR REMOVING DEPOSITS OF BICARBONATES, CARBONATES AND HYDROXIDES OF CALCIUM, MAGNESIUM AND IRON FROM CERAMIC, METAL, PORCELAIN, CEMENT, BRICK, CHROME AND STEEL SURFACES; ALL OF THE AFOREMENTIONED GOODS BEING ENVIRONMENTALLY FRIENDLY (U.S. CLS. 1, 5, 6, 10, 26 AND 46).

**CLASS 3—COSMETICS AND CLEANING PREPARATIONS**

FOR (BASED ON 44(E)) NON-MEDICATED PERSONAL CARE PRODUCTS, NAMELY, SHAMPOOS AND HAIR CONDITIONERS, SKIN MOISTURIZERS, SKIN LOTION, BODY LOTION, BODY CREAM, SKIN CREAM, ANTI-AGING CREAM, NON-MEDICATED STRETCH MARK SKIN CREAMS, NON-MEDICATED COSMETIC LOTIONS AND CREAMS FOR HANDS, NAILS, SKIN, FACE, HAIR, AND VARICOSE VEINS; DEPILATORY LOTIONS AND CREAMS, SHAVING LOTIONS AND CREAMS, NON-MEDICATED SKIN CARE PREPARATIONS, NAMELY, ANTI-WRINKLE LOTIONS AND CREAMS, AND LOTIONS AND CREAMS FOR TREATING DRY AND DAMAGED SKIN, FOR ANTI-AGING, FOR SKIN FIRMLING, FOR STRETCH MARKS, AND UNDER EYE AND EYELID FIRMLING; NON-MEDICATED SKIN CARE PREPARATIONS IN GEL FORM, NAMELY, DEPILATORY GELS, SHAVING GELS, SHOWER GELS, MOISTURIZING AND ANTI-AGING GELS, AND STRETCH MARK GELS; OILS, NAMELY, BATH OILS, BODY OILS, COSMETIC OILS, AND NUTRITIONAL OILS FOR COSMETIC PURPOSES, NON-MEDICATED SKIN AND BEAUTY SERUMS, PETROLEUM JELLY FOR COSMETIC PURPOSES, SOAPS, LIQUID SOAPS, BAR SOAPS, ANTI-BACTERIAL LIQUID SOAPS, ANTI-BACTERIAL BAR SOAPS, HUMAN BODY SPRAYS, REFRESHING BODY SPRAYS, BODY WASHING SOAPS, BUBBLE BATH, BODY AND FACIAL SCRUBS, MASKS, NAMELY, BEAUTY MASKS, FACIAL MASKS, BODY MASKS, GEL EYE MASKS, SKIN MASKS, AND SKIN MOISTURIZER MASKS, NON-MEDICATED SKIN CARE PREPARATIONS IN THE NATURE OF FACE PEELS, NON-MEDICATED SKIN CARE PREPARATIONS, AND WRINKLE REMOVING SKIN CARE PREPARATIONS, COSMETIC SUN PROTECTION CREAMS AND LOTIONS, SUN CREAMS, AFTER-SUN LOTIONS WITH OR WITHOUT SPF, SUN BLOCK, SELF-TANNING CREAMS AND LOTIONS, TALCUM POWDERS; PERSONAL DEODORANTS, ALL PURPOSE CLEANERS, FLOOR CLEANING PREPARATIONS, GLASS CLEANERS, LAUNDRY BLEACH, FABRIC SOFTENER, LAUNDRY DETERGENTS, DETERGENT SOAPS, DISH DETERGENTS, HAND SOAPS, ANTI-BACTERIAL SOAPS, DEODORIZERS FOR PETS, IMPREGNATED CLEANING CLOTHS, DISPOSABLE WIPES IN SHEET FORM IMPREGNATED WITH CHEMICALS OR COMPOUNDS FOR USE ON HUMAN SKIN AND HOUSEHOLD, INDUSTRIAL, AND COMMERCIAL SURFACES, PRE-MOISTENED COSMETIC WIPES IN SHEET FORM, PRE-MOISTENED COSMETIC TOWELETTES, AND PRE-MOISTENED TOWELETTES IMPREGNATED WITH DISHWASHING DETERGENT; NON-MEDICATED SKIN CARE PREPARATIONS FOR ANTI-AGING, ANTI-WRINKLES, SKIN CONDITIONING AND SKIN FIRMLING, NAMELY, DAYTIME AND NIGHTTIME PILLS, CAPSULES, GEL CAPS AND TABLETS; HOUSEHOLD DEODORANTS; ALL OF THE AFOREMENTIONED GOODS BEING ENVIRONMENTALLY FRIENDLY (U.S. CLS. 1, 4, 6, 50, 51 AND 52).

**CLASS 4—LUBRICANTS AND FUELS**

FOR (BASED ON 44(E)) ALL PURPOSE LUBRICANTS FOR HOUSEHOLD USE; ALL OF THE AFOREMENTIONED GOODS BEING ENVIRONMENTALLY FRIENDLY (U.S. CLS. 1, 6 AND 15).

**CLASS 5—PHARMACEUTICALS**

FOR (BASED ON 44(E)) NUTRITIONAL SUPPLEMENTS FOR HUMAN CONSUMPTION FOR ANTI-WRINKLES, NAMELY, CAPSULES, GEL CAPS AND TABLETS; DIETARY SUPPLEMENTS FOR HUMAN CONSUMPTION FOR ANTI-WRINKLES, NAMELY, PILLS, CAPSULES, GEL CAPS AND TABLETS; NUTRACEUTICALS FOR USE AS A DIETARY SUPPLEMENT FOR ANTI-WRINKLES, NAMELY, PILLS, CAPSULES, GEL CAPS AND TABLETS; MEDICATED SKIN CARE PREPARATIONS FOR ANTI-WRINKLES, NAMELY, DAYTIME AND NIGHTTIME PILLS, CAPSULES, GEL CAPS AND TABLETS; HOUSEHOLD DEODORANTS; ANTIBACTERIAL CLEANERS, ANTI-MICROBIAL HANDWASH, ALL PURPOSE DISINFECTANTS, AIR, CAR AND CARPET DEODORIZERS, ROOM FRESHENER IN SPRAY FORM, AND MEDICATED PRE-MOISTENED TOWELETTES; MEDICATED LOTIONS AND CREAMS FOR VARICOSE VEINS AND FOOT AND LEG MUSCLE AND JOINT PAIN; ANTIBACTERIAL ALCOHOL SKIN SANITIZER GEL; (BASED ON INTENT TO USE) BARS FOR HUMAN CONSUMPTION, NAMELY, MEAL REPLACEMENT BARS, VITAMINS AND MINERALS FORMED AND PACKAGED AS BARS; POWDERS FOR HUMAN CONSUMPTION, NAMELY, POWDERED NUTRITIONAL SUPPLEMENT DRINK MIXES, MEAL REPLACEMENT POWDERS; SHAKES FOR HUMAN CONSUMPTION, NAMELY, MEAL REPLACEMENT SHAKES, VITAMINS FOR HUMAN CONSUMPTION; NUTRITIONAL SUPPLEMENTS FOR HUMAN CONSUMPTION FOR ANTI-AGING, SKIN CONDITIONING, SKIN FIRMLING, WEIGHT LOSS AND WEIGHT MAINTENANCE, NAMELY, CAPSULES, GEL CAPS AND TABLETS; DIETARY SUPPLEMENTS FOR HUMAN CONSUMPTION FOR ANTI-AGING, SKIN CONDITIONING, SKIN FIRMLING, WEIGHT LOSS AND WEIGHT MAINTENANCE, NAMELY, PILLS, CAPSULES, GEL CAPS AND TABLETS; NUTRACEUTICALS FOR USE AS A DIETARY SUPPLEMENT FOR ANTI-AGING, SKIN CONDITIONING, SKIN FIRMLING, WEIGHT LOSS AND WEIGHT MAINTENANCE, NAMELY, PILLS, CAPSULES, GEL CAPS AND TABLETS; AND MEDICATED SKIN CARE PREPARATIONS FOR ANTI-AGING, SKIN CONDITIONING AND SKIN FIRMLING, NAMELY, DAYTIME AND NIGHTTIME PILLS, CAPSULES, GEL CAPS AND TABLETS; ALL OF THE AFOREMENTIONED GOODS BEING ENVIRONMENTALLY FRIENDLY (U.S. CLS. 6, 18, 44, 46, 51 AND 52).

**CLASS 21—HOUSEWARES AND GLASS**

FOR (BASED ON 44(E)) CLEANING CLOTHS, PRE-MOISTENED TOWELETTES AND SPONGES FOR HOUSEHOLD CLEANING PURPOSES; ALL OF THE AFOREMENTIONED GOODS BEING ENVIRONMENTALLY FRIENDLY (U.S. CLS. 2, 13, 23, 29, 30, 33, 40 AND 50).

ZHALEH DELANEY, EXAMINING ATTORNEY

SN 77-222,238. RIG FUNDING (CAYMAN) LIMITED, GEORGE TOWN, GRAND CAYMAN, CAYMAN ISLANDS, FILED 7-5-2007.

# SEADRAGON

THE MARK CONSISTS OF STANDARD CHARACTERS WITHOUT CLAIM TO ANY PARTICULAR FONT, STYLE, SIZE, OR COLOR.

PRIORITY CLAIMED UNDER SEC. 44(D) ON UNITED KINGDOM APPLICATION NO. 2442762, FILED 1-4-2007, REG. NO. 2442762A, DATED 2-8-2008, EXPIRES 1-4-2017.

**CLASS 6—METAL GOODS**

FOR METAL BUILDING MATERIALS, NAMELY, METAL BEAMS, PRE-FABRICATED METAL ARCHITECTURAL COLUMNS, METAL ROOF TRUSSES, STRUCTURAL STEEL, SHEET METAL, STEEL PLATES FOR DOORWAYS AND STAIRS, STEEL DRILL FLOORS, STEEL DRILL LEGS, STEEL SHEETS FOR USE ON AN OFFSHORE DRILLING VESSEL, STEEL RODS, NAMELY, METAL CONNECTING RODS, STRUCTURAL BEAMS OF METAL; PREFABRICATED BUILDINGS OF METAL; TRANSPORTABLE PORTABLE BUILDINGS OF METAL; ARTICLES MADE OF METAL AND METAL ALLOYS FOR USE IN EQUIPPING OIL AND GAS RIGS, AND SEA-GOING VESSELS AND SHIPS, NAMELY, METAL PONTOONS USED FOR SUPPORTING DECKS, METAL FLOORING, NAMELY, DECK FLOORS, PRE-FABRICATED HOUSES, NAMELY, DECK HOUSES, PRE-FABRICATED METAL PLATFORMS, NAMELY, HELICOPTER DECKS; PIPES AND TUBES OF METAL; SHEETS AND PLATES OF STEEL; ANCHORS; STEEL ANCHOR PLATES; REINFORCED BUILDING MATERIALS OF METAL, NAMELY, BOARDS OF METAL; REINFORCED BUILDING MATERIALS OF METAL, NAMELY, PANELS OF METAL; DOORS OF METAL; CEILINGS PANELS OF METAL; WINDOW FRAMES OF METAL; FLOORS OF METAL; GIRDERS OF METAL; LADDERS AND STEP STOOLS OF METAL; CONSTRUCTION ELEMENTS MADE OF METAL, NAMELY, BRACES, BELTS OF METAL FOR LOAD HANDLING, NAMELY, HARNESS AND STRAPS, ALL OF METAL FOR LOAD HANDLING; PIPE FITTINGS OF METAL FOR BUILDINGS; REINFORCING MATERIALS OF METAL FOR BUILDING PURPOSES; MOORING BUOYS OF METAL; MOORING BOLLARDS OF METAL; PROPS OF METAL, NAMELY, CONSTRUCTION SUPPORTS; REINFORCING MATERIALS OF METAL FOR BUILDING PURPOSES AND CONNECTING PIPES; METAL SHELTER STRUCTURES, NAMELY, TURRETS OF METAL; STRUCTURAL STEEL, NAMELY, METAL BEAMS AND METAL JOISTS; STEEL FABRICATIONS, NAMELY, PREFABRICATED METAL BUILDINGS; SHEET METAL FABRICATIONS, NAMELY, SHEET METAL LININGS; CONTAINERS OF METAL FOR STORAGE AND TRANSPORT OF GOODS; FLOATING DOCKS OF METAL; FLOATING CONTAINERS OF METAL FOR COMPRESSED GAS OR LIQUID AIR; CLADDING OF METAL FOR CONSTRUCTION; NON-ELECTRIC CABLES OF METAL; METALLIC ACCOMMODATION MODULES, NAMELY, METAL SHELTER STRUCTURES; OFFSHORE PRODUCTION UNITS IN THE NATURE OF OFFSHORE DRILLING PLATFORMS FOR THE PRODUCTION OF OIL AND GAS, SEMI-SUBMERSIBLE UNITS IN THE NATURE OF OFFSHORE DRILLING PLATFORMS FOR THE PRODUCTION OF OIL AND GAS, OFFSHORE DRILLING PLATFORMS, ALL MADE OF METAL; METAL STORAGE TANKS, METAL RESERVOIRS, STORAGE STRUCTURES IN THE FORM OF METAL FLUID STORAGE TANKS, METAL STORAGE SHEDS AND METAL STORAGE DRUMS, METAL PENSTOCK PIPES, AND GENERAL PURPOSE METAL STORAGE CONTAINERS, METAL PIPING, AND METAL CONDUITS USED IN THE EXPLORATION, PRODUCTION, REFINING, STORAGE, TRANSPORT, AND PROCESSING OF LIQUIDS AND GASES; METALLIC PLUMBING MATERIALS, NAMELY, INDUSTRIAL METAL HOSES; METAL SAFETY DOORS, METAL GATES AND METAL LOADING RAMPS; BARRELS OF METAL FOR USE ON DRILLING RIGS; OIL AND GAS DRILLING PLATFORMS; SEMI-SUBMERSIBLE OFFSHORE DRILLING PLATFORMS; METAL CRANE HOOKS (U.S. CLS. 2, 12, 13, 14, 23, 25 AND 50).

**CLASS 7—MACHINERY**

FOR DRILLING RIGS, NAMELY, JACK UP RIGS FOR THE PRODUCTION OF OIL AND GAS, OIL AND GAS OFFSHORE DRILLING RIGS, OIL AND GAS DRILLING RIGS, SEMI-SUBMERSIBLE OFFSHORE DRILLING RIGS; POWER OPERATED APPARATUS FOR USE IN DRILLING, NAMELY, DRILL CHUCKS; DRILLING BITS; DRILLING HEADS; DRILLING MACHINES BEING ELECTRICAL DRILLS, DRILLING RIGS AND DRILLING RIGS FOR DRILLING WELLS OFFSHORE OR ON LAND; CRANES; COMPONENTS OF CRANES, NAMELY, WIRE WINCHES, TUGGER WINCHES, UTILITY WINCHES, WIRE HOISTS, OPERATOR CABINS (U.S. CLS. 13, 19, 21, 23, 31, 34 AND 35).

**CLASS 9—ELECTRICAL AND SCIENTIFIC APPARATUS**

FOR POWER SUPPLIES FOR CRANES; ELECTRICAL APPARATUS AND INSTRUMENTS FOR USE IN EQUIPPING AND BUILDING OIL AND GAS RIGS AND PLATFORMS, SEMI-SUBMERSIBLE RIGS, SEAGOING VESSELS, AND SHIPS, NAMELY, ELECTRIC INSTRUMENT CONTROL PANELS, ELECTRIC INSTRUMENT CONTROL CONSOLES, ELECTRIC CIRCUITS, NAMELY, INSTRUMENT CONTROL CIRCUITS, DATA PROCESSORS, COMPUTERS; APPARATUS AND INSTRUMENTS FOR CONDUCTING, SWITCHING, TRANSFORMING, ACCUMULATING, PRODUCING, REGULATING OR CONTROLLING ELECTRICITY, NAMELY, ELECTRICAL WIRES, TRANSFORMERS, BATTERIES, ELECTRICAL OUTLETS (U.S. CLS. 21, 23, 26, 36 AND 38).

**CLASS 12—VEHICLES**

FOR ARTICLES MADE OF METAL AND METAL ALLOYS FOR USE IN EQUIPPING OIL AND GAS RIGS, AND SEA-GOING VESSELS AND SHIPS, NAMELY, BOAT HULLS; VESSELS; SEAGOING VESSELS; SHIPS; BOATS (U.S. CLS. 19, 21, 23, 31, 35 AND 44).

**CLASS 19—NON-METALLIC BUILDING MATERIALS**

FOR BUILDING AND CONSTRUCTION MATERIALS, NAMELY, NON-METAL BEAMS, NON-METAL COLUMNS, NON-METAL ROOF TRUSSES, NON-METALLIC REINFORCEMENTS FOR CONCRETE AND WOOD BUILDING CONSTRUCTION, NAMELY, PLATES FOR DOORWAYS AND STAIRS, NON-METALLIC DRILL FLOORS, NON-METALLIC DRILL LEGS, BUILDING MATERIALS, NAMELY, NON-METALLIC PLASTIC SHEETS FOR USE ON AN OFFSHORE DRILLING VESSEL, NON-METALLIC REINFORCEMENTS FOR CONCRETE AND WOOD BUILDING CONSTRUCTION, NAMELY, CONNECTING RODS, NON-METALLIC STRUCTURAL BEAMS; PREFABRICATED NON-METALLIC BUILDINGS; NON-METALLIC TRANSPORTABLE PORTABLE BUILDINGS; NON-METALLIC ACCOMMODATION MODULES, NAMELY, SHELTER STRUCTURES; CEMENT MIXES; CEMENT POSTS AND SLABS; CONCRETE; FLOATING DOCKS NOT OF METAL; NON-METALLIC BUILDING MATERIALS, NAMELY, PLASTIC WATER PIPES; FLOORING MATERIALS NOT OF METAL, NAMELY, LAMINATE AND RUBBER FLOORING; ROOFING MATERIALS NOT OF METAL, NAMELY, ROOFING SHINGLES AND TILES (U.S. CLS. 1, 12, 33 AND 50).

**CLASS 37—CONSTRUCTION AND REPAIR**

FOR BUILDING MAINTENANCE AND REPAIR SERVICES; BUILDING CONSTRUCTION SERVICES; FABRICATION SERVICES, NAMELY, STEEL STRUCTURE CONSTRUCTION WORKS; OIL WELL CASING, TUBING, AND DRILL PIPE INSTALLATION SERVICES; DRILLING PLATFORMS MAINTENANCE AND REPAIR SERVICES; BUILDING SEALING AND INSTALLATION OF BUILDING INSULATION SERVICES; ELECTRICAL AND POWER GENERATING MACHINERY INSTALLATION, MAINTENANCE AND REPAIR; PIPELINE CONSTRUCTION AND MAINTENANCE; FABRICATION AND INSTALLATION OF OFFSHORE LIVING QUARTERS LOCATED ON DRILLING PLATFORMS; REBUILDING MACHINES THAT HAVE BEEN WORN OR PARTIALLY DESTROYED; CUSTOM SHIPBUILDING; TELEPHONE INSTALLATION AND REPAIR; REFURBISHMENT SERVICES, NAMELY, RENOVATION OF BUILDINGS; PROJECT MANAGEMENT OF REFURBISHMENT, NAMELY, CONSTRUCTION MANAGEMENT; DRILLING EQUIPMENT REFURBISHMENT; COATING AND PAINTING SERVICES; SERVICING OF CRANES FOR LOADING AND UNLOADING PURPOSES; CONSTRUCTION, REPAIR, RETROFITTING, CONVERSION, MAINTENANCE AND SERVICING OF BUILDINGS; CONSTRUCTION, MAINTENANCE AND REPAIR OF COMMERCIAL AND INDUSTRIAL STORAGE AND PROCESSING SPHERES, TERMINALS AND TOWERS; CONSTRUCTION MANAGEMENT AND SUPERVISION; CONSTRUCTION OF VESSELS, LARGE

STEEL STRUCTURES AND FACILITIES FOR THE EXPLORATION, PRODUCTION, REFINING, STORAGE, TRANSPORT, AND PROCESSING OF LIQUIDS AND GASES; INSTALLATION AND MAINTENANCE OF HEATING, VENTILATION AND AIR CONDITIONING APPARATUS; PLUMBING; RENOVATION OF PLUMBING; MAINTENANCE OF PLUMBING; CONSTRUCTION MANAGEMENT; CONSTRUCTION AND PROJECT MANAGEMENT SERVICES FOR VESSELS, LARGE STEEL STRUCTURES AND FACILITIES FOR EXPLORATION, PRODUCTION, REFINING, STORAGE, TRANSPORT, DISTRIBUTION, AND PROCESSING OF NATURAL RESOURCES, LIQUIDS, AND GASES; MAINTENANCE AND REPAIR OF TANKS, VESSELS, LARGE STEEL STRUCTURES, EQUIPMENT AND FACILITIES FOR THE EXPLORATION, PRODUCTION, REFINING, STORAGE, TRANSPORT, DISTRIBUTION, AND PROCESSING OF NATURAL RESOURCES, LIQUIDS AND GASES; INFORMATION, ADVISORY AND CONSULTANCY SERVICES IN RELATION TO ALL THE AFORESAID SERVICES (U.S. CLS. 100, 103 AND 106).

**CLASS 42—SCIENTIFIC AND COMPUTER SERVICES**

FOR ENGINEERING SERVICES; STRUCTURAL ENGINEERING; DESIGN AND ENGINEERING OF OIL AND GAS PRODUCTION FACILITIES FOR OTHERS; NAVAL ARCHITECTURE DESIGN SERVICES; ARCHITECTURE DESIGN SERVICES; CUSTOM DESIGN OF DRILLING PLATFORMS; ELECTRICAL DESIGN AND ENGINEERING OF DRILLING RIGS; DESIGN OF SEMI-SUBMERSIBLE DRILLING RIGS; OIL PIPELINE PIPE DESIGN; DESIGN OF OFFSHORE LIVING QUARTERS LOCATED ON DRILLING PLATFORMS; CONSULTING SERVICES IN THE FIELDS OF ENGINEERING AND ARCHITECTURAL DESIGN; INDUSTRIAL DESIGN SERVICES; CONSTRUCTION DRAFTING; UNDERWATER EXPLORATION; CONSUMER PRODUCT SAFETY TESTING SERVICES; GEOLOGICAL RESEARCH AND SURVEYS; INSTALLATION OF COMPUTER SOFTWARE; MAINTENANCE OF COMPUTER SOFTWARE, UPDATING OF COMPUTER SOFTWARE; MATERIAL TESTING; OIL FIELD TESTING AND SURVEYS; MECHANICAL RESEARCH; RESEARCH AND DEVELOPMENT FOR OTHERS IN THE FIELD OF OIL AND GAS PRODUCTION; OFFSHORE, SEMI-SUBMERSIBLE AND JACK UP DRILLING RIG DESIGN; ENGINEERING SERVICES; INSPECTING OFFSHORE RIGS AND OTHER PRODUCTS RELATING TO OFFSHORE DRILLING; ENGINEERING SERVICES FOR TANKS, VESSELS, LARGE STEEL STRUCTURES, EQUIPMENT AND FACILITIES FOR EXPLORATION, PRODUCTIONS, REFINING, STORAGE, TRANSPORT, DISTRIBUTION, AND PROCESSING OF NATURAL RESOURCES, LIQUIDS, AND GASES; INFORMATION AND CONSULTANCY SERVICES IN RELATION TO ALL THE AFORESAID SERVICES (U.S. CLS. 100 AND 101).  
BENJAMIN OKEKE, EXAMINING ATTORNEY

SN 77-250,852, RECKITT & COLMAN (OVERSEAS) LIMITED, HULL HU8 7DS, ENGLAND, FILED 8-9-2007.

**STOPS IN ITS TRACKS**

THE MARK CONSISTS OF STANDARD CHARACTERS WITHOUT CLAIM TO ANY PARTICULAR FONT, STYLE, SIZE, OR COLOR.

OWNER OF ERPN CMNTY TM OFC REG. NO. 006162374, DATED 7-17-2008, EXPIRES 8-2-2017.

**CLASS 3—COSMETICS AND CLEANING PREPARATIONS**

FOR NON-MEDICATED TOILETRIES; NON-MEDICATED SKIN CARE PREPARATIONS FOR THE TREATMENT OF ACNE, SKIN BLEMISHES AND SKIN CONDITIONS; PEN-SHAPED APPLICATORS CONTAINING NON-MEDICATED SKIN CARE PREPARATIONS FOR THE TREATMENT OF ACNE, SKIN BLEMISHES AND SKIN CONDITIONS; CONCEALERS FOR ACNE AND FACIAL BLEMISHES; PEN-SHAPED APPLICATORS CONTAINING CONCEALERS FOR ACNE AND FACIAL BLEMISHES (U.S. CLS. 1, 4, 6, 50, 51 AND 52).

**CLASS 5—PHARMACEUTICALS**

FOR MEDICATED PREPARATIONS FOR THE TREATMENT OF ACNE, BLEMISHES AND FOR SKIN CARE; PEN-SHAPED APPLICATORS CONTAINING MEDICATED SKIN CARE PREPARATIONS, NAMELY, TOPICAL TREATMENTS FOR ACNE, BLEMISHES AND SKIN CONDITIONS; PHARMACEUTICAL PREPARATIONS FOR THE TREATMENT OF ACNE, SKIN BLEMISHES AND SKIN CONDITIONS (U.S. CLS. 6, 18, 44, 46, 51 AND 52).

TOBY BULLOFF, EXAMINING ATTORNEY

SN 77-299,403. PETROLEUM MARKETING ANALYSIS, INC, DBA AURA OIL & LAMP CREATIONS, DELRAY BEACH, FL. FILED 10-9-2007.

**Aura Oil & Lamp Creations**

THE MARK CONSISTS OF STANDARD CHARACTERS WITHOUT CLAIM TO ANY PARTICULAR FONT, STYLE, SIZE, OR COLOR.

NO CLAIM IS MADE TO THE EXCLUSIVE RIGHT TO USE "OIL & LAMP CREATIONS", APART FROM THE MARK AS SHOWN.

**CLASS 4—LUBRICANTS AND FUELS**

FOR LAMP FUEL; LAMP OIL; LAMP WICKS (U.S. CLS. 1, 6 AND 15).  
FIRST USE 5-1-2002; IN COMMERCE 5-1-2002.

**CLASS 11—ENVIRONMENTAL CONTROL APPARATUS**

FOR OIL LAMPS (U.S. CLS. 13, 21, 23, 31 AND 34).  
FIRST USE 5-31-2001; IN COMMERCE 5-31-2001.  
JANICE KIM, EXAMINING ATTORNEY

SN 77-334,580. 7525451 CANADA INC., MONTREAL, CANADA, FILED 11-20-2007.

**AAER**

THE MARK CONSISTS OF STANDARD CHARACTERS WITHOUT CLAIM TO ANY PARTICULAR FONT, STYLE, SIZE, OR COLOR.

OWNER OF CANADA REG. NO. 1372262, DATED 11-12-2010, EXPIRES 11-12-2020.

THE WORDING "AAER" HAS NO MEANING IN A FOREIGN LANGUAGE.

**CLASS 7—MACHINERY**

FOR WIND TURBINES AND PARTS THEREOF (U.S. CLS. 13, 19, 21, 23, 31, 34 AND 35).

**CLASS 37—CONSTRUCTION AND REPAIR**

FOR ASSEMBLY AND MAINTENANCE OF WIND TURBINES (U.S. CLS. 100, 103 AND 106).

**CLASS 40—MATERIAL TREATMENT**

FOR MANUFACTURE OF WIND TURBINES TO THE ORDER AND SPECIFICATION OF OTHERS (U.S. CLS. 100, 103 AND 106).

JEFF DEFORD, EXAMINING ATTORNEY

SN 77-343,283. BROWN, STACY SMITH, NEW ORLEANS, LA. FILED 12-4-2007.

**LEMONADE BRIGADE**

THE MARK CONSISTS OF STANDARD CHARACTERS WITHOUT CLAIM TO ANY PARTICULAR FONT, STYLE, SIZE, OR COLOR.

**CLASS 36—INSURANCE AND FINANCIAL**

FOR CHARITABLE FUNDRAISING SERVICES; PHILANTHROPIC AND ELEEMOSYNARY SERVICES IN THE FIELD OF MONETARY DONATIONS (U.S. CLS. 100, 101 AND 102).

**CLASS 41—EDUCATION AND ENTERTAINMENT**

FOR EDUCATIONAL SERVICES, NAMELY, CONDUCTING WORKSHOPS IN THE FIELD OF ENTREPRENEURSHIP AND BUSINESS FORMATION, ORGANIZATION, AND MANAGEMENT, AND DISTRIBUTION OF COURSE MATERIALS IN CONNECTION THEREWITH (U.S. CLS. 100, 101 AND 107).

KIMBERLY FRYE, EXAMINING ATTORNEY

SN 77-435,794. JIAXING DEYONG TEXTILES CO., LTD, ZHEJIANG, CHINA, FILED 3-31-2008.

**ecolayer**

PRIORITY CLAIMED UNDER SEC. 44(D) ON CHINA APPLICATION NO. 6641925, FILED 3-15-2008, REG. NO. 6641925, DATED 7-21-2010, EXPIRES 7-20-2020.

PRIORITY CLAIMED UNDER SEC. 44(D) ON CHINA APPLICATION NO. 6642926, FILED 3-15-2008, REG. NO. 6642926, DATED 7-21-2010, EXPIRES 7-20-2020.

**CLASS 24—FABRICS**

FOR TEXTILE FABRICS FOR THE MANUFACTURE OF CLOTHING; KNITTED FABRIC; FELT AND NON-WOVEN TEXTILE FABRIC; OIL CLOTHS; BED SHEETS; BED PADS; NURSING SHEETS, NAMELY, BED SHEETS USED IN THE HEALTH CARE, HOME-HEALTH CARE AND NURSING HOME INDUSTRIES; PILLOW CASES; PILLOW COVERS; WATERPROOF FABRIC FOR MANUFACTURING CLOTHING, FURNITURE AND AUTOMOBILE UPHOLSTERY, AND LUGGAGE (U.S. CLS. 42 AND 50).

**CLASS 25—CLOTHING**

FOR CLOTHING, NAMELY, UNIFORMS, JACKETS, WATERPROOF JACKETS AND PANTS, RAINWEAR, JOGGING SUITS, SWEAT PANTS, SUITS, SKIRTS, SKI SUITS, SKI PANTS, TROUSERS, COATS, APRONS, GLOVES, MITTENS, BABIES' DIAPERS OF TEXTILE; WARMTH-KEEPING SUPPORTS, NAMELY, LEG WARMERS AND ARM WARMERS; HATS AND CAPS; SHOES AND BOOTS EXCLUDING SHOE DOWELS, SHOE PEGS, SHOE HANDLES, HOBNAI AND SHOE PROTECTIVE METAL MEMBERS; ATHLETIC UNIFORMS; ATHLETIC FOOTWEAR (U.S. CLS. 22 AND 39).

ALLISON HOLTZ, EXAMINING ATTORNEY

SN 77-439,283. LIQUID HOLDING COMPANY, INC., BRODHEADSVILLE, PA. FILED 4-3-2008.

# ECOLOGIC

THE MARK CONSISTS OF STANDARD CHARACTERS WITHOUT CLAIM TO ANY PARTICULAR FONT, STYLE, SIZE, OR COLOR.

**CLASS 1—CHEMICALS**

FOR LAWN AND GARDEN CARE PRODUCTS, NAMELY, FERTILIZERS AND PLANT GROWTH STIMULANTS (U.S. CLS. 1, 5, 6, 10, 26 AND 46).

**CLASS 5—PHARMACEUTICALS**

FOR LAWN AND GARDEN CARE PRODUCTS, NAMELY, WEED KILLERS (U.S. CLS. 6, 18, 44, 46, 51 AND 52).

RONALD MCMORROW, EXAMINING ATTORNEY

SN 77-439,340. LIQUID HOLDING COMPANY, INC., BRODHEADSVILLE, PA. FILED 4-3-2008.



OWNER OF U.S. REG. NOS. 2,208,895 AND 2,988,994.  
NO CLAIM IS MADE TO THE EXCLUSIVE RIGHT TO USE "COMPANY", APART FROM THE MARK AS SHOWN.  
THE COLOR(S) BLACK AND GREEN IS/ARE CLAIMED AS A FEATURE OF THE MARK.

THE MARK CONSISTS OF THE WORD "ECOLOGIC" WITH THE "ECO" IN GREEN PRINT WITH A CAPITAL "E" AND THE LETTERS "CO" IN LOWER CASE LETTERS AND THE "LOGIC" IN BLACK PRINT WITH A CAPITAL "L" AND THE "OGIC" IN LOWER CASE LETTERS WITH A LEAF COMING OUT OF THE TOP OF THE "G" IN THE WORD "LOGIC" FADING FROM BLACK TO GREEN. UNDERNEATH THE WORD "ECOLOGIC" ARE THE WORDS "FROM THE LIQUID FENCE COMPANY" IN BLACK PRINT.

**CLASS 1—CHEMICALS**

FOR LAWN AND GARDEN CARE PRODUCTS, NAMELY, FERTILIZERS AND PLANT GROWTH STIMULANTS (U.S. CLS. 1, 5, 6, 10, 26 AND 46).

**CLASS 5—PHARMACEUTICALS**

FOR LAWN AND GARDEN CARE PRODUCTS, NAMELY, WEED KILLERS (U.S. CLS. 6, 18, 44, 46, 51 AND 52).

RONALD MCMORROW, EXAMINING ATTORNEY

SN 77-450,307. BACKBONE ENTERTAINMENT, IRVINE, CA. FILED 4-16-2008.



NO CLAIM IS MADE TO THE EXCLUSIVE RIGHT TO USE "GAMES", APART FROM THE MARK AS SHOWN.

THE MARK CONSISTS OF A SERIES OF HORIZONTAL LINES PRESENTED IN AN HOURGLASS SHAPE ABOVE THE WORDS "DOUBLE HELIX GAMES".

**CLASS 9—ELECTRICAL AND SCIENTIFIC APPARATUS**

FOR COMPUTER GAME CARTRIDGES AND DISCS; COMPUTER GAME SOFTWARE; ELECTRONIC GAME SOFTWARE FOR HANDHELD ELECTRONIC DEVICES; ELECTRONIC GAME SOFTWARE FOR WIRELESS DEVICES; VIDEO GAME CARTRIDGES AND DISCS; DOWNLOADABLE COMPUTER GAMES VIA THE INTERNET AND WIRELESS DEVICES (U.S. CLS. 21, 23, 26, 36 AND 38).

**CLASS 42—SCIENTIFIC AND COMPUTER SERVICES**

FOR DESIGNING AND DEVELOPING COMPUTER GAME SOFTWARE AND VIDEO GAME SOFTWARE FOR USE WITH COMPUTERS, VIDEO GAME PROGRAM SYSTEMS AND COMPUTER NETWORKS (U.S. CLS. 100 AND 101).

FIRST USE 3-27-2008; IN COMMERCE 3-27-2008.  
BERYL GARDNER, EXAMINING ATTORNEY



SN 77-531,232. AIR NEW ZEALAND LIMITED, AUCKLAND, NEW ZEALAND, FILED 7-25-2008.

# ALTITUDE

THE MARK CONSISTS OF STANDARD CHARACTERS WITHOUT CLAIM TO ANY PARTICULAR FONT, STYLE, SIZE, OR COLOR.

OWNER OF NEW ZEALAND REG. NO. 783788, DATED 2-5-2008, EXPIRES 2-5-2018.

## CLASS 37—CONSTRUCTION AND REPAIR

FOR REPAIR AND INSTALLATION SERVICES, NAMELY, OF VEHICLES, AND APPARATUS FOR LOCOMOTION BY AIR OR WATER; VEHICLE INTERIOR CONSTRUCTION AND REPAIR; AUTOMOTIVE MAINTENANCE AND REPAIR; AIRCRAFT REPAIR AND MAINTENANCE; REPAIR AND MAINTENANCE OF AIRCRAFT PARTS AND ACCESSORIES, NAMELY, AIRCRAFT ENGINES AND AIRCRAFT ENGINE PARTS; MAINTENANCE, OVERHAUL AND REPAIR OF AIRCRAFT PARTS, AIRCRAFT ENGINES AND AIRCRAFT ENGINE PARTS; CONSULTANCY, ADVISORY, AND INFORMATION SERVICES RELATING TO THE FOREGOING (U.S. CLS. 100, 103 AND 106).

## CLASS 42—SCIENTIFIC AND COMPUTER SERVICES

FOR SCIENTIFIC AND TECHNOLOGICAL SERVICES AND RESEARCH AND DESIGN RELATING THERETO IN THE FIELD OF AVIATION, INDUSTRIAL ANALYSIS, ENGINEERING, AND INTERIOR DESIGN ALL RELATED TO THE FIELD OF AVIATION; INDUSTRIAL ANALYSIS AND RESEARCH SERVICES IN THE FIELD OF SCIENCE AND TECHNOLOGY, INDUSTRIAL ANALYSIS, ENGINEERING, AND INTERIOR DESIGN ALL RELATED TO THE FIELD OF AVIATION; ENGINEERING SERVICES, NAMELY, ENGINEERING IN THE FIELD OF AVIATION AND DESIGN ENGINEERING IN THE FIELD OF AVIATION; ENGINEERING SERVICES, NAMELY, AIRCRAFT DESIGN; INTERIOR DESIGN SERVICES INCLUDING THE DESIGN OF INTERIOR DECOR FOR COMMERCIAL BUILDINGS AND/OR THE INTERIOR DECOR FOR VEHICLES; INTERIOR DESIGN SERVICES FOR AIRCRAFT; CONSULTANCY, ADVISORY, AND INFORMATION SERVICES RELATING TO THE FOREGOING (U.S. CLS. 100 AND 101).

THOMAS MANOR, EXAMINING ATTORNEY

SN 77-536,661. SEA PEN HOLDINGS PTY LTD, COOMERA, AUSTRALIA, FILED 8-1-2008.

# SEA PEN

THE MARK CONSISTS OF STANDARD CHARACTERS WITHOUT CLAIM TO ANY PARTICULAR FONT, STYLE, SIZE, OR COLOR.

OWNER OF AUSTRALIA REG. NO. 1253583, DATED 7-25-2008, EXPIRES 7-25-2018.

NO CLAIM IS MADE TO THE EXCLUSIVE RIGHT TO USE "SEA", APART FROM THE MARK AS SHOWN.

## CLASS 12—VEHICLES

FOR BOAT HULL PROTECTORS, NAMELY, FRAMES WITH BUMPERS AND CHAFE GUARDS NOT BUMPERS OR PADS FOR PILINGS OR DOCK POSTS; REMOTELY OPERATED DRY DOCK BOAT HULL PROTECTORS, NAMELY, FRAMES WITH BUMPERS AND CHAFE GUARDS; SHAPED COVERS FOR THE UNDERSIDE OF BOATS; TARPAULINS ADAPTED BY SHAPING INTO FORMS FOR USE WITH BOATS; SLEEPING BERTHS FOR BOATS; HOODS FOR WATERCRAFT; SUNSHIELDS FOR USE ON WATERCRAFT; BOAT LAUNCHING TROLLEYS; DAVITS FOR BOATS; BOAT HOOKS; BUFFERS FOR ATTACHMENT TO WATERCRAFT; BUMPERS FOR ATTACHMENT TO WATERCRAFT; BUOYANCY BAGS ADAPTED FOR USE WITH WATERCRAFT; CARRIERS FOR TRANSPORTING WATERCRAFT; TRAILERS FOR TRANSPORTING WATERCRAFT; AND INSTRUCTIONAL MATERIALS SOLD TOGETHER WITH THE AFORESAID GOODS, AND PARTS AND FITTINGS FOR ALL THE AFORESAID GOODS (U.S. CLS. 19, 21, 23, 31, 35 AND 44).

## CLASS 19—NON-METALLIC BUILDING MATERIALS

FOR FLOATING DOCKS, NOT OF METAL, FOR MOORING INDIVIDUAL WATERCRAFT FOR THE PURPOSE OF PROTECTING THE HULL AND RUNNING GEAR OF THE WATERCRAFT AND PARTS AND FITTINGS THEREFOR; FLOATING DOCKS, NOT OF METAL, SUBMERSED UNDERWATER, FOR MOORING INDIVIDUAL WATERCRAFT AND PARTS AND FITTINGS THEREFOR; MOORING DOCKS, NOT OF METAL FOR MOORING INDIVIDUAL WATERCRAFT FOR THE PURPOSE OF PROTECTING THE HULL AND RUNNING GEAR OF THE WATERCRAFT AND PARTS AND FITTINGS THEREFOR; DRY DOCK FLOATING BOAT HULL PROTECTORS, NAMELY, SUBMERSIBLE FRAMING INCORPORATING PROTECTIVE MESH NETTING, NOT OF METAL, FOR MOORING INDIVIDUAL WATERCRAFT AND PARTS AND FITTINGS THEREFOR; NON METALLIC FLOATING BREAKWATERS FOR THE USE IN BOAT MARINAS AND PARTS AND FITTINGS THEREFOR; NON METALLIC MEMBRANES FOR WATERPROOFING AND PARTS AND FITTINGS THEREFOR; NON METALLIC SEA CARPETS FOR STABILIZING SOIL AND PARTS AND FITTINGS THEREFOR; REINFORCING MESH MADE OF TEXTILE FIBERS FOR CONSTRUCTION PURPOSES AND PARTS AND FITTINGS THEREFOR; AND INSTRUCTIONAL MATERIALS SOLD TOGETHER WITH THE AFORESAID GOODS (U.S. CLS. 1, 12, 33 AND 50).

## CLASS 39—TRANSPORTATION AND STORAGE

FOR RENTAL OF BERTHS IN THE NATURE OF UNDERWATER SUBMERSIBLE FRAMES INCORPORATING A PROTECTIVE MESH NET FOR BOATS; PROVISION OF VESSEL MOORINGS IN THE NATURE OF UNDERWATER SUBMERSIBLE FRAMES INCORPORATING A PROTECTIVE MESH NET; RENTAL OF MOORINGS IN THE NATURE OF UNDERWATER SUBMERSIBLE FRAMES INCORPORATING A PROTECTIVE MESH NET FOR WATERCRAFT; CHARTERING OF WATERCRAFT; UNLOADING AND REFLOATING OF WATERCRAFT; MARINE LIFTING AND CRANAGE SERVICES USING FLOATING AND LAND BASED CRANES NOT FOR CONSTRUCTION PURPOSES; WATERCRAFT TRANSPORTATION SERVICES; ARRANGEMENT OF THE STORAGE OF WATERCRAFT; DELIVERY OF CARGO; LOGISTICS SERVICES, NAMELY, TRANSPORT, PACKAGING, AND STORAGE OF ALL TYPES OF GOODS; PROVISION OF INFORMATION RELATING TO VESSEL MOORINGS; ADVISORY SERVICES RELATING TO THE STORAGE OF BOATS; PROVIDING INFORMATION, BY ELECTRONIC MEANS AND VIA A GLOBAL COMPUTER NETWORK, ABOUT ALL OF THE AFORESAID SERVICES (U.S. CLS. 100 AND 105).

JEFF DEFORD, EXAMINING ATTORNEY

SN 77-551,668. AACHI SPICES & FOODS, ANNA NAGAR, CHENNAI, INDIA, FILED 8-20-2008.

# AACHI

THE MARK CONSISTS OF STANDARD CHARACTERS WITHOUT CLAIM TO ANY PARTICULAR FONT, STYLE, SIZE, OR COLOR.

THE FOREIGN WORDING IN THE MARK TRANSLATES INTO ENGLISH AS A DISTINGUISHED LADY.

## CLASS 29—MEATS AND PROCESSED FOODS

FOR MEAT, FISH, POULTRY AND GAME; MEAT EXTRACTS; PRESERVED, DRIED AND COOKED FRUIT AND VEGETABLES; FRUIT SAUCES, NAMELY, CRANBERRY SAUCE AND APPLESAUCE; FRUIT CHIPS; EGGS; EDIBLE OIL; COCONUT OIL AND FAT; COCONUT POWDER; DAL (U.S. CL. 46).

## CLASS 30—STAPLE FOODS

FOR TURMERIC; FLOUR; PREPARATIONS MADE FROM CEREALS, NAMELY, INDIAN FOOD VARIETIES PREPARED FROM CEREALS, INCLUDING IDLIS, DOSAS, VADAS, BONDAS, AND BAJJIS; BREAD; PASTRY; CONFECTIONERY, NAMELY, CRYSTAL SUGAR, FONDANTS, CONFECTIONERY CHIPS FOR BAKING; ICES; HONEY; TREACLE; YEAST; BAKING POWDER; SALT; MUSTARD; VINEGAR; SAUCES, EXCLUDING SALAD DRESSINGS; COFFEE; TEA; COCOA; SUGAR; RICE; TAPIOCA; SAGO AND ARTIFICIAL COFFEE; MASALA RICE FOR BIRIYANI, AND OTHER SPICES FOR MEAT DISHES OF INDIA, NAMELY, MASALA POWDER AND SPICES FOR MEAT DISHES SUCH AS MUTTON BIRIYANI, MUTTON CURRY, MUTTON CHOPS, MUTTON FRY, MUTTON CHUKKA, CHICKEN BIRIYANI, CHILI CHICKEN, CHICKEN FRY, CHICKEN LOLLIPOP, GRILLED CHICKEN, PEPPER CHICKEN; ASAFETIDA; CHILI POWDERS; APPALUM AND PAPADUM; FRUIT SAUCES EXCLUDING CRANBERRY SAUCE AND APPLESAUCE (U.S. CL. 46).

GISELLE AGOSTO, EXAMINING ATTORNEY

SN 77-559,077. 911979 ALBERTA LTD., CALGARY, CANADA, FILED 8-29-2008.



OWNER OF CANADA REG. NO. TMA642,404, DATED 6-17-2005, EXPIRES 6-17-2020.

NO CLAIM IS MADE TO THE EXCLUSIVE RIGHT TO USE "BRAND", APART FROM THE MARK AS SHOWN.

THE COLOR(S) WHITE AND RED IS/ARE CLAIMED AS A FEATURE OF THE MARK.

THE MARK CONSISTS OF THE COLOR RED APPEARING AS AN OVAL CARRIER WITH THE COLOR WHITE APPEARING AS THE WORDING "LIFE" IN LARGE FONT ABOVE THE WORD "BRAND" IN SMALL WHITE FONT WITHIN THE OVAL.

## CLASS 3—COSMETICS AND CLEANING PREPARATIONS

FOR (BASED ON 44(E), CANADIAN REG. NO. TMA642,404) MANICURE IMPLEMENTS, NAMELY, EMERY BOARDS AND EMERY FINISHING DISCS, NAMELY, COATED ABRASIVE SANDPAPER IN THE FORM OF A DISC, FOOT CARE PRODUCTS, NAMELY, PUMICE STONES (U.S. CLS. 1, 4, 6, 50, 51 AND 52).

## CLASS 5—PHARMACEUTICALS

FOR (BASED ON 44(E), CANADIAN REG. NO. TMA642,404) THROAT LOZENGES AND MEDICAL THROAT SPRAYS; PREPARATIONS FOR TREATING COUGH AND COLD, NAMELY, COUGH AND COLD CAPSULES, COUGH AND COLD POWDERS, COUGH AND COLD PREPARATIONS WITH CODEINE, NASAL SPRAY PREPARATIONS, ANTIHISTAMINES; ANTACIDS AND NAUSEA TREATMENT PREPARATIONS, LAXATIVES, ANTI-DIARRHEAL LIQUID MEDICATION; MULTIVITAMIN PREPARATIONS, MINERAL SUPPLEMENTS, CALCIUM SUPPLEMENTS; DIETARY HEALTH FOOD SUPPLEMENTS, NAMELY, BREWER'S YEAST FOR MEDICAL PURPOSES, CALCIUM AND MAGNESIUM SUPPLEMENTS, GARLIC AND PARSLEY SUPPLEMENTS FOR MEDICAL USE, GARLIC CAPSULES FOR MEDICAL USE, ODORLESS GARLIC OIL CAPSULES FOR MEDICAL USE, GELATIN CAPSULES SOLD EMPTY FOR PHARMACEUTICALS, GINSENG CAPSULES FOR MEDICAL USE, LECITHIN FOR USE AS A DIETARY SUPPLEMENT, OAT BRAN FIBRE FOR USE AS A DIETARY SUPPLEMENT AND WHEAT GERM CAPSULES FOR USE AS A DIETARY SUPPLEMENT; EYE, EAR AND NOSE REMEDIES AND ACCESSORIES, NAMELY, EAR ACHE DROPS, SALINE SOLUTION FOR MEDICAL USE; ALCOHOL AND ALCOHOL PADS FOR TOPICAL USE; MEDICAL ADHESIVE TAPE, GAUZE BANDAGES, TOPICAL FIRST AID CREAM, OINTMENT AND LIQUIDS; ABSORBENT COTTON FOR MEDICAL USE; MEDICINAL PRODUCTS, NAMELY, WITCH HAZEL, HYDROGEN PEROXIDE, RUBBING ALCOHOL, CASTOR OIL, GLYCERINE, EPSOM SALTS, ALL OF THE FOREGOING USED FOR MEDICAL PURPOSES; DISPOSABLE INCONTINENCE PRODUCTS, NAMELY, BRIEFS, UNDERWEAR SHIELDS, UNDERGARMENTS, TAMPONS, MAXIPADS, SANITARY NAPKINS, PANTY SHIELDS AND LINERS; SUPPOSITORIES; PHARMACEUTICALS COMPRISING ANALGESICS, SEDATIVES, COUGH AND COLD REMEDIES, DERMATOLOGICAL PHARMACEUTICAL PREPARATIONS, LINIMENTS, ANTACIDS, ANTISEPTICS, ANTIBIOTICS, ANTIBIOTIC OINTMENTS, ANTI-INFLAMMATORY OINTMENTS, ANTI-ITCH OINTMENTS, MEDICATED DIAPER RASH OINTMENTS, MENTHOLATED OINTMENT FOR MEDICAL USE, NUTRITIONAL HERBAL TONIC SUPPLEMENTS, HERBAL SUPPLEMENT TONICS FOR THE SUPPORT OF IMMUNE SYSTEM FUNCTION; MEDICINAL MINERALS; VITAMINS; SURGICAL DRESSINGS; PHARMACEUTICAL PREPARATIONS FOR TREATING WOUNDS; (BASED ON INTENT-TO-USE) DIAPER PAIL DEODORIZERS (U.S. CLS. 6, 18, 44, 46, 51 AND 52).

## CLASS 8—HAND TOOLS

FOR (BASED ON 44(E), CANADIAN REG. NO. TMA642,404) MANICURE IMPLEMENTS, NAMELY, CUTICLE KNIVES, CUTICLE CLIPPERS, CUTICLE PUSHERS, CUTICLE SCISSORS, MANICURE STICKS, NAIL BUFFERS, NAIL CLIPPERS, NAIL FILES, NAIL SCISSORS, SAFETY SCISSORS, BARBER SCISSORS; BLACKHEAD REMOVERS, EYEBROW TWEEZERS, EYELASH CURLERS; RAZORS; CUTLERY, NAMELY, FORKS, SPOONS AND KNIVES; BABY CARE PRODUCTS, NAMELY, NAIL CLIPPERS, DISPOSABLE CUTLERY, NAMELY, FORKS, SPOONS AND KNIVES; FOOT CARE PRODUCTS, NAMELY, NAIL CLIPPERS, CORN BLADES; PLASTIC CUTLERY; (BASED ON INTENT-TO-USE) UTILITY KNIVES (U.S. CLS. 23, 28 AND 44).

**CLASS 10—MEDICAL APPARATUS**

FOR (BASED ON 44(E), CANADIAN REG. NO. TMA642,404) BABY PRODUCTS, NAMELY, PACIFIERS, TEETHERS, BABY BOTTLES, NIPPLES FOR BABY BOTTLES, TEETHING RINGS, NASAL ASPIRATORS, EAR SYRINGES; EYE BATH CUPS; THERAPEUTIC HOT AND COLD PACKS; SPORT WRAPS, NAMELY, BACK SUPPORTS FOR MEDICAL PURPOSES, MEDICAL BRACES FOR TENNIS ELBOW, WRIST SHAPERS FOR MEDICAL PURPOSES, WRIST SUPPORTS FOR MEDICAL PURPOSES, ANKLE SUPPORTS FOR MEDICAL PURPOSES, ELBOW SUPPORTS FOR MEDICAL PURPOSES, KNEE SUPPORTS FOR MEDICAL PURPOSES; ELASTIC BANDAGES; SPLINTS FOR MEDICAL PURPOSES; MEASURING STORAGE SUPPLIES, NAMELY, MEDICINE DROPPERS SOLD EMPTY; BED PANS; BREAST PUMPS; ICE BAGS FOR MEDICAL PURPOSES; INVALID RINGS FOR MEDICAL PURPOSES; NIPPLE SHIELDS; RECTAL SYRINGES; URINALS; LATEX MEDICAL GLOVES; EYE DROPPERS; MEDICINE SPOONS; HEATING PADS FOR MEDICAL PURPOSES; FEVER THERMOMETERS; INFRARED HEATING DEVICES, NAMELY, INFRARED RADIATOR UNITS FOR THERAPEUTIC PURPOSES, FEMININE HYGIENE ACCESSORIES, NAMELY, DOUCHE BAGS AND VAGINAL SYRINGES SOLD EMPTY FOR PHARMACEUTICAL PREPARATIONS; (BASED ON INTENT-TO-USE) BABY PRODUCTS, NAMELY, PACIFIERS, TEETHERS, TEETHING RINGS (U.S. CLS. 26, 39 AND 44).

SANDRA BUJA, EXAMINING ATTORNEY

SN 77-577,254. BLUE INK SYNDICATE, INC., SAN DIEGO, CA. FILED 9-23-2008.

**Splash!**  
ANIMALS

NO CLAIM IS MADE TO THE EXCLUSIVE RIGHT TO USE "ANIMALS", APART FROM THE MARK AS SHOWN. THE MARK CONSISTS OF THE WORD "SPASH!" LOCATED OVER THE WORD "ANIMALS".

**CLASS 16—PAPER GOODS AND PRINTED MATTER**

FOR PAINTINGS, GREETING CARDS, AND ADDRESS BOOKS (U.S. CLS. 2, 5, 22, 23, 29, 37, 38 AND 50). FIRST USE 3-1-2008; IN COMMERCE 3-1-2008.

**CLASS 25—CLOTHING**

FOR CLOTHING, NAMELY, SHIRTS, T-SHIRTS, POLO SHIRTS, SWEATSHIRTS, PAJAMAS, NIGHT SHIRTS, NIGHT GOWNS, PANTS, COVERALLS, SHORTS, DRESSES, TOPS, SHIRTDRESSES, UNDERGARMENTS, NECKTIES, FOOTWEAR, HATS, CAPS, SHOES; BABY LAYETTES (U.S. CLS. 22 AND 39).

FIRST USE 3-1-2008; IN COMMERCE 3-1-2008.

**CLASS 41—EDUCATION AND ENTERTAINMENT**

FOR WORKSHOPS AND SEMINARS IN THE FIELDS OF PAINTING WILDLIFE, ANIMALS, PLANTS AND NATURE (U.S. CLS. 100, 101 AND 107).

FIRST USE 3-1-2008; IN COMMERCE 3-1-2008. TRACY WHITTAKER-BROWN, EXAMINING ATTORNEY

SN 77-596,023. EAGLE RIDGE MANUFACTURING, DBA TECHCO, ANAHEIM, CA. FILED 10-20-2008.

**TECHCO**

THE MARK CONSISTS OF STANDARD CHARACTERS WITHOUT CLAIM TO ANY PARTICULAR FONT, STYLE, SIZE, OR COLOR.

**CLASS 7—MACHINERY**

FOR AUTOMOTIVE ENGINE COMPONENTS, NAMELY, THROTTLE BODIES (U.S. CLS. 13, 19, 21, 23, 31, 34 AND 35).

**CLASS 9—ELECTRICAL AND SCIENTIFIC APPARATUS**

FOR MASS AIR FLOW SENSOR (U.S. CLS. 21, 23, 26, 36 AND 38).

**CLASS 12—VEHICLES**

FOR HIGH PERFORMANCE LAND VEHICLE PARTS, NAMELY, POWER TRAIN COMPONENTS COMPRISED OF CLUTCH, TRANSMISSION, DRIVE SHAFT AND DIFFERENTIAL; AUTOMOBILE CHASSIS COMPONENTS, NAMELY, WATTS LINK SUSPENSION SYSTEMS FOR AUTOMOBILES; BRAKES FOR VEHICLES; TOWER BRACES, NAMELY, SUSPENSION STRUTS; AUTOMOBILE CHASSIS STIFFENING BRACES; SUSPENSIONS SPRINGS AND SUSPENSION STRUTS FOR VEHICLES; AUTOMOBILE BODY COMPONENTS, NAMELY, AUTOMOBILE HOODS AND AUTOMOBILE DOOR AND ROOF PANELS; INTERIOR COMPONENTS FOR LAND VEHICLES, NAMELY, SEATS, STEERING WHEELS, AND INTERIOR DOOR PANELS (U.S. CLS. 19, 21, 23, 31, 35 AND 44).

**CLASS 40—MATERIAL TREATMENT**

FOR AUTOMOTIVE MANUFACTURING AND ASSEMBLY FOR OTHERS (U.S. CLS. 100, 103 AND 106).

**CLASS 42—SCIENTIFIC AND COMPUTER SERVICES**

FOR AUTOMOTIVE ENGINEERING; AUTOMOTIVE DESIGN; AND AUTOMOTIVE ENGINE DYNAMOMETER TESTING SERVICES FOR OTHERS (U.S. CLS. 100 AND 101).

FIRST USE 9-29-2008; IN COMMERCE 9-29-2008. JESSICA FATHY, EXAMINING ATTORNEY

SN 77-621,268. PHT SERVICES LTD, COLUMBIA, SC. FILED 11-25-2008.

**PHTS**

OWNER OF U.S. REG. NOS. 2,002,245, 2,694,711 AND OTHERS.

THE MARK CONSISTS OF THE STYLIZED LETTERS "PHTS" ACCENTED BY SHADOWING AND SURROUNDED BY A PORTION OF A BLOCK DESIGN.

#### **CLASS 35—ADVERTISING AND BUSINESS**

FOR OUTSOURCING IN THE FIELD OF INSURANCE SERVICES, NAMELY, UNDERWRITING OR ADMINISTERING PROPERTY AND CASUALTY INSURANCE, EMPLOYEE BENEFITS AND EMPLOYEE BENEFITS CONSULTING; OUTSOURCING IN THE FIELD OF ENVIRONMENTAL HEALTH AND SAFETY SERVICES; BUSINESS RISK MANAGEMENT SERVICES FOR HEALTH CARE FACILITIES (U.S. CLS. 100, 101 AND 102).

FIRST USE 4-1-1996; IN COMMERCE 4-1-1996.

#### **CLASS 36—INSURANCE AND FINANCIAL**

FOR INSURANCE SERVICES, NAMELY, UNDERWRITING OR ADMINISTERING PROPERTY AND CASUALTY INSURANCE, AND WORKERS COMPENSATION INSURANCE; FINANCIAL RISK MANAGEMENT SERVICES FOR HEALTH CARE FACILITIES (U.S. CLS. 100, 101 AND 102).

FIRST USE 4-1-1996; IN COMMERCE 4-1-1996.

#### **CLASS 41—EDUCATION AND ENTERTAINMENT**

FOR EDUCATIONAL SERVICES, NAMELY, CONDUCTING WORKSHOPS, SEMINARS AND CLASSES IN THE FIELD OF HEALTH CARE, HOSPITAL ACCREDITATION, STAFF ORGANIZATION, HEALTH CARE FACILITY MANAGEMENT, HEALTH CARE EDUCATION, ENVIRONMENTAL HEALTH AND SAFETY AND OCCUPATIONAL HEALTH (U.S. CLS. 100, 101 AND 107).

FIRST USE 4-1-1996; IN COMMERCE 4-1-1996.

#### **CLASS 44—MEDICAL, BEAUTY AND AGRICULTURAL SERVICES**

FOR EMPLOYEE SUBSTANCE ABUSE TESTING SERVICES (U.S. CLS. 100 AND 101).

FIRST USE 4-1-1996; IN COMMERCE 4-1-1996.

#### **CLASS 45—PERSONAL AND LEGAL SERVICES**

FOR PRE-EMPLOYMENT BACKGROUND SCREENING SERVICES; SECURITY GUARD SERVICES; ENVIRONMENTAL HEALTH AND SAFETY SERVICES IN THE NATURE OF SAFETY CONSULTING SERVICES IN THE FIELDS OF HAZARD ASSESSMENTS AND ABATEMENT PROCEDURES; PROVIDING HEALTH CARE REGULATORY COMPLIANCE INFORMATION BY TELEPHONE HOTLINE (U.S. CLS. 100 AND 101).

FIRST USE 4-1-1996; IN COMMERCE 4-1-1996.  
KEVON CHISOLM, EXAMINING ATTORNEY

SN 77-677,357. MR. GARETH ALEXIS WATSON JONES, NORTH YORKSHIRE, UNITED KINGDOM, FILED 2-24-2009.

# EXPERIA

THE MARK CONSISTS OF STANDARD CHARACTERS WITHOUT CLAIM TO ANY PARTICULAR FONT, STYLE, SIZE, OR COLOR.

PRIORITY CLAIMED UNDER SEC. 44(D) ON ERPN CMNTY TM OFC APPLICATION NO. 007208036, FILED 9-3-2008, REG. NO. 007208036, DATED 6-8-2010, EXPIRES 9-3-2018.

#### **CLASS 9—ELECTRICAL AND SCIENTIFIC APPARATUS**

FOR ELECTRICAL CONTROLLING DEVICES FOR MEDICAL AND THERAPEUTIC STRUCTURES, APPARATUS OR EQUIPMENT; ELECTRICAL CONTROLLING DEVICES FOR SENSORY, TACTILE, VISUAL, ORAL OR MENTAL STIMULATION APPARATUS AND EQUIPMENT; ELECTRICAL CONTROLLING DEVICES FOR APPARATUS, EQUIPMENT, STRUCTURES, GAMES, TOYS AND PLAYTHINGS THAT IS USED WITH CHILDREN, ADULTS, THE ABLE BODIED, HANDICAPPED OR DISABLED HAVING A THERAPEUTIC OR STIMULATORY EFFECT ON THE USER; ELECTRICAL CONTROLLING DEVICES FOR ROOMS, BOOTHS, FLOORS, WALL PANELS OR OTHER STRUCTURES HAVING FEATURES OR SURFACES INTERACTIVE WITH THE USER; ELECTRICAL CONTROLLING DEVICES FOR SCULPTURED OR TEXTURED WALLS, FLOORS OR PANELS HAVING A THERAPEUTIC EFFECT ON THE USER; ELECTRICAL CONTROLLING DEVICES FOR ROOMS, WALLS, FLOORS, PANELS OR OTHER STRUCTURES HAVING ILLUMINATION OR OTHER LIGHT EFFECTS, AIR FLOW OR AUDITORY EFFECTS FOR USE BY OR FOR THE TREATMENT OF CHILDREN AND ADULTS AND FOR ABLE BODIED, HANDICAPPED OR DISABLED PEOPLE; ELECTRICAL CONTROLLING DEVICES FOR GAMES, TOYS OR PLAYTHINGS; ELECTRICAL CONTROLLING DEVICES FOR SPORTS OR PLAY APPARATUS OR EQUIPMENT FOR USE BY THE PHYSICALLY OR MENTALLY IMPAIRED OR HANDICAPPED; ELECTRICAL CONTROLLING DEVICES FOR CONSTRUCTIONAL OR INTERACTIVE TOYS OR GAMES; ELECTRICAL CONTROLLING DEVICES FOR GAMES, TOYS OR PLAYTHINGS INCORPORATING SENSORY STIMULATION EFFECTS; ELECTRICAL CONTROLLING DEVICES FOR TACTILE, VISUAL, OLFACTORY OR AUDIO EFFECTS; ELECTRICAL CONTROLLING DEVICES FOR MANIPULATIVE TOYS, GAMES OR PLAYTHINGS; INTERACTIVE SWITCH BOXES FOR USE IN CONTROLLING MEDICAL AND THERAPEUTIC STRUCTURES, APPARATUS OR EQUIPMENT, SENSORY, TACTILE, VISUAL, ORAL OR MENTAL STIMULATION APPARATUS AND EQUIPMENT; INTERACTIVE ELECTRICAL CONTROLLING DEVICES THAT ARE TRIGGERED BY SOUND, MOVEMENT OR LIGHT FOR USE IN CONTROLLING MEDICAL AND THERAPEUTIC STRUCTURES, APPARATUS OR EQUIPMENT, SENSORY, TACTILE, VISUAL, ORAL OR MENTAL STIMULATION APPARATUS AND EQUIPMENT; FIBER OPTIC CABLES; PHOTOGRAPHIC PROJECTORS; COMPONENT PARTS AND COMPONENT FITTINGS FOR ELECTRICAL CONTROLLING DEVICES; COMPUTERS FOR SENSORY, TACTILE, VISUAL, AURAL OR MENTAL STIMULATION THAT ARE USED FOR EDUCATIONAL, INTERACTIVE, CALMING, THERAPEUTIC, AND/OR STIMULATORY PURPOSES; DOWNLOADABLE ELECTRONIC PUBLICATIONS IN THE NATURE OF NEWSLETTERS, CATALOGUES, BROCHURES, E-BOOKS, TEACHING MATERIALS IN THE FIELD OF OCCUPATIONAL THERAPY AND MULTI-SENSORY DEVELOPMENT AND IN THE FIELD OF OCCUPATIONAL THERAPY AND MULTI-SENSORY DEVELOPMENT APPARATUS, EQUIPMENT AND TEACHING AIDS; DOWNLOADABLE SOFTWARE IN THE FIELD OF OCCUPATIONAL THERAPY AND MULTI-SENSORY DEVELOPMENT AND IN THE FIELD OF OCCUPATIONAL THERAPY AND MULTI-SENSORY DEVELOPMENT APPARATUS, TEACHING AIDS (U.S. CLS. 21, 23, 26, 36 AND 38).

#### **CLASS 10—MEDICAL APPARATUS**

FOR MEDICAL AND THERAPEUTIC APPARATUS OR EQUIPMENT SPECIFICALLY FOR THERAPEUTIC USE, NAMELY, DEVICES FOR ROOMS, BOOTHS, FLOORS, WALL PANELS OR OTHER STRUCTURES HAVING ILLUMINATION OR OTHER LIGHT EFFECTS, AIR-FLOW, OLFACTORY, VESTIBULAR, TACTILE, PROPRIOCEPTION OR AUDITORY OR OTHER SENSORY EFFECTS; MEDICAL APPARATUS AND EQUIPMENT SPECIFICALLY FOR THERAPEUTIC USE FOR CHILDREN AND ADULTS AND FOR THE ABLE BODIED, HANDICAPPED OR DISABLED HAVING A THERAPEUTIC OR STIMULATORY EFFECT ON THE USER, NAMELY, DEVICES FOR ROOMS, BOOTHS, FLOORS, WALL PANELS OR OTHER STRUCTURES HAVING ILLUMINATION OR OTHER LIGHT EFFECTS, AIR-

FLOW, OLFACTORY, VESTIBULAR, TACTILE, PROPRICEPTION OR AUDITORY OR OTHER SENSORY EFFECTS; COMPONENT PARTS AND COMPONENT FITTINGS FOR MEDICAL AND THERAPEUTIC APPARATUS OR EQUIPMENT SPECIFICALLY FOR THERAPEUTIC USE IN ROOMS, BOOTHS, FLOORS, WALL PANELS OR OTHER STRUCTURES HAVING ILLUMINATION OR OTHER LIGHT EFFECTS, AIRFLOW, OLFACTORY, VESTIBULAR, TACTILE, PROPRICEPTION OR AUDITORY OR OTHER SENSORY EFFECTS; SENSORY, TACTILE, VISUAL, AURAL OR MENTAL STIMULATION APPARATUS AND EQUIPMENT BEING ELECTRICAL MEDICAL AND THERAPEUTIC APPARATUS OR EQUIPMENT SPECIFICALLY FOR THERAPEUTIC USE FOR EDUCATIONAL, INTERACTIVE, CALMING, THERAPEUTIC AND/OR STIMULATORY PURPOSES FOR USE IN ROOMS, BOOTHS, FLOORS, WALL PANELS OR OTHER STRUCTURES HAVING ILLUMINATION OR OTHER LIGHT EFFECTS, AIRFLOW, OLFACTORY, VESTIBULAR, TACTILE, PROPRICEPTION OR AUDITORY EFFECTS; MEDICAL AND THERAPEUTIC APPARATUS OR EQUIPMENT SPECIFICALLY FOR THERAPEUTIC USE FOR GYMNASIAC AND SPORTING USE BY PEOPLE WITH PHYSICAL AND/OR MENTAL DISABILITIES, NAMELY, MEDICAL AND THERAPEUTIC USE TRAMPOLINES, SWINGS, BOLSTERS, AND THERAPEUTIC APPARATUS FOR SENSORY INTEGRATION; MEDICAL AND THERAPEUTIC APPARATUS OR EQUIPMENT SPECIFICALLY FOR THERAPEUTIC USE IN THE NATURE OF THERAPEUTIC USE ACTION SKILL GAMES, CAUSE AND EFFECT TOYS, MULTIPLE SKILL ACTIVITY TOYS, DEVELOPMENT AND ASSESSMENT GAMES, TOYS AND PLAYTHINGS, TRAMPOLINES, SWINGS, BOLSTERS, AND OTHER THERAPEUTIC APPARATUS AND EQUIPMENT FOR SENSORY INTEGRATION; COMPONENT PARTS AND COMPONENT FITTINGS FOR MEDICAL AND THERAPEUTIC APPARATUS OR EQUIPMENT SPECIFICALLY FOR THERAPEUTIC USE IN THE NATURE OF THERAPEUTIC USE ACTION SKILL GAMES, MULTIPLE SKILL ACTIVITY TOYS, DEVELOPMENT AND ASSESSMENT GAMES, TOYS AND PLAYTHINGS, TRAMPOLINES, SWINGS, BOLSTERS, AND OTHER GOODS AND OTHER THERAPEUTIC USE APPARATUS AND EQUIPMENT FOR SENSORY INTEGRATION (U.S. CLS. 26, 39 AND 44).

#### **CLASS 11—ENVIRONMENTAL CONTROL APPARATUS**

FOR ELECTRIC LIGHTING FIXTURES, NAMELY, PROJECTOR LAMPS, LED (LIGHT EMITTING DIODE) LIGHTING FIXTURES PRODUCING A RANGE OF LIGHTING EFFECTS; ELECTRIC LIGHTING FIXTURES DESIGNED TO STIMULATE THE VISUAL SENSES, NAMELY, PROJECTOR LAMPS, LED (LIGHT EMITTING DIODE) LIGHTING FIXTURES PRODUCING A RANGE OF LIGHTING EFFECTS; ELECTRIC LIGHTING FIXTURES INCORPORATING OPTICAL FIBERS, NAMELY, PROJECTOR LAMPS, LED (LIGHT EMITTING DIODE) LIGHTING FIXTURES PRODUCING A RANGE OF LIGHTING EFFECTS; LIGHTING TUBES; LIGHTING TUBES, NAMELY, ILLUMINATED BUBBLE TUBES; COMPONENT PARTS AND COMPONENT FITTINGS FOR PROJECTOR LAMPS, LED (LIGHT EMITTING DIODE) LIGHTING FIXTURES (U.S. CLS. 13, 21, 23, 31 AND 34).

#### **CLASS 16—PAPER GOODS AND PRINTED MATTER**

FOR PUBLICATIONS, NAMELY, BROCHURES, BOOKLETS, AND TEACHING MATERIALS IN THE FIELD OF OCCUPATIONAL THERAPY AND MULTI-SENSORY DEVELOPMENT AND IN THE FIELD OF OCCUPATIONAL THERAPY AND MULTI-SENSORY DEVELOPMENT APPARATUS, EQUIPMENT AND TEACHING AIDS; INSTRUCTIONAL AND TEACHING MATERIALS IN THE FIELD OF OCCUPATIONAL THERAPY AND MULTI-SENSORY DEVELOPMENT AND IN THE FIELD OF OCCUPATIONAL THERAPY AND MULTI-SENSORY DEVELOPMENT APPARATUS, EQUIPMENT AND TEACHING AIDS; INSTRUCTIONAL AND TEACHING WRITING INSTRUMENTS; STATIONERY, WRITING INSTRUMENTS; PERIODICALS IN THE FIELD OF OCCUPATIONAL THERAPY AND MULTI-SENSORY DEVELOPMENT AND IN THE FIELD OF

OCCUPATIONAL THERAPY AND MULTI-SENSORY DEVELOPMENT APPARATUS, EQUIPMENT AND TEACHING AIDS; BOOKS IN THE FIELD OF OCCUPATIONAL THERAPY AND MULTI-SENSORY DEVELOPMENT AND IN THE FIELD OF OCCUPATIONAL THERAPY AND MULTI-SENSORY DEVELOPMENT APPARATUS, EQUIPMENT AND TEACHING AIDS; NOTEBOOKS; MAGAZINES IN THE FIELD OF OCCUPATIONAL THERAPY AND MULTI-SENSORY DEVELOPMENT AND IN THE FIELD OF OCCUPATIONAL THERAPY AND MULTI-SENSORY DEVELOPMENT APPARATUS, EQUIPMENT AND TEACHING AIDS; CATALOGS IN THE FIELD OF OCCUPATIONAL THERAPY AND MULTI-SENSORY DEVELOPMENT AND IN THE FIELD OF OCCUPATIONAL THERAPY AND MULTI-SENSORY DEVELOPMENT APPARATUS, EQUIPMENT AND TEACHING AIDS; SOFTWARE PROGRAMS AND DATA PROCESSING PROGRAMS IN PRINTED FORM; PUBLICATIONS, NAMELY, NEWSLETTERS, CATALOGUES, BROCHURES, BOOKLETS AND TEACHING MATERIALS IN THE FIELD OF OCCUPATIONAL THERAPY AND MULTI-SENSORY DEVELOPMENT APPARATUS, EQUIPMENT AND TEACHING AIDS (U.S. CLS. 2, 5, 22, 23, 29, 37, 38 AND 50).

#### **CLASS 19—NON-METALLIC BUILDING MATERIALS**

FOR PREFABRICATED NON-METAL BUILDINGS COMPRISING ROOMS, BOOTHS, FLOORS, WALLS, PANELS OR OTHER STRUCTURES HAVING FEATURES OR SURFACES INTERACTIVE WITH THE USER, OR COMPRISING SCULPTURED OR TEXTURED WALLS, FLOORS OR PANELS HAVING A GENERALLY THERAPEUTIC EFFECT ON THE USER; PREFABRICATED NON-METAL BUILDINGS COMPRISING ROOMS, WALLS, FLOORS, PANELS OR OTHER STRUCTURES HAVING ILLUMINATION, OR OTHER LIGHT EFFECTS, AIR FLOW OR AUDITORY EFFECTS AND HAVING A GENERALLY THERAPEUTIC EFFECT ON CHILDREN, ADULTS, THE ABLE BODIED, HANDICAPPED OR DISABLED PEOPLE (U.S. CLS. 1, 12, 33 AND 50).

#### **CLASS 28—TOYS AND SPORTING GOODS**

FOR GAMES, TOYS AND PLAYTHINGS, NAMELY, ACTION SKILL GAMES; MULTIPLE ACTIVITY TOYS IN THE NATURE OF CAUSE AND EFFECT TOYS; MULTIPLE SKILL ACTIVITY TOYS; ACTION SKILL GAMES IN THE NATURE OF VISUAL STIMULATION GAMES; MULTIPLE ACTIVITY TOYS IN THE NATURE OF VISUAL STIMULATION TOYS; ACTION SKILL GAMES AND MULTIPLE ACTIVITY TOYS IN THE NATURE OF TACTILE FEEDBACK GAMES AND TOYS; ACTION SKILL GAMES AND MULTIPLE ACTIVITY TOYS IN THE NATURE OF AUDITORY FEEDBACK GAMES AND TOYS; ACTION SKILL GAMES AND MULTIPLE ACTIVITY TOYS IN THE NATURE OF TRACKING GAMES AND TOYS; ACTION SKILL GAMES AND MULTIPLE ACTIVITY TOYS IN THE NATURE OF MOTOR SKILLS GAMES AND TOYS; ACTION SKILL GAMES AND MULTIPLE ACTIVITY TOYS IN THE NATURE OF DEVELOPMENT AND ASSESSMENT GAMES AND TOYS; ACTION SKILL GAMES AND MULTIPLE ACTIVITY TOYS IN THE NATURE OF CONSTRUCTIONAL OR INTERACTIVE TOYS AND GAMES, NAMELY, ACTION SKILL GAMES, CAUSE AND EFFECT TOYS, MULTIPLE SKILL ACTIVITY TOYS, VISUAL STIMULATION GAMES AND TOYS; ACTION SKILL GAMES AND MULTIPLE ACTIVITY TOYS IN THE NATURE OF MOTOR SKILLS GAMES AND TOYS; ACTION SKILL GAMES AND MULTIPLE ACTIVITY TOYS IN THE NATURE OF DEVELOPMENT AND ASSESSMENT GAMES AND TOYS; ACTION SKILL GAMES AND MULTIPLE ACTIVITY TOYS IN THE NATURE OF TACTILE AND MANIPULATIVE TOYS AND GAMES, NAMELY, ACTION SKILL GAMES, CAUSE AND EFFECT TOYS, MULTIPLE SKILL ACTIVITY TOYS AND VISUAL STIMULATION GAMES AND TOYS (U.S. CLS. 22, 23, 38 AND 50).

**CLASS 35—ADVERTISING AND BUSINESS**

FOR THE BRINGING TOGETHER, FOR THE BENEFIT OF OTHERS, OF A VARIETY OF GOODS ENABLING CUSTOMERS TO CONVENIENTLY VIEW AND PURCHASE THOSE GOODS IN THE FIELD OF ELECTRICAL CONTROLLING DEVICES FOR MEDICAL AND THERAPEUTIC STRUCTURES, APPARATUS OR EQUIPMENT, ELECTRICAL CONTROLLING DEVICES FOR SENSORY, TACTILE, VISUAL, ORAL OR MENTAL STIMULATION APPARATUS AND EQUIPMENT, ELECTRICAL CONTROLLING DEVICES FOR APPARATUS, EQUIPMENT, STRUCTURES, GAMES, TOYS AND PLAYTHINGS THAT IS USED WITH CHILDREN, ADULTS, THE ABLE BODIED, HANDICAPPED OR DISABLED HAVING A THERAPEUTIC OR STIMULATORY EFFECT ON THE USER, ELECTRICAL CONTROLLING DEVICES FOR ROOMS, BOOTHS, FLOORS, WALL PANELS OR OTHER STRUCTURES HAVING FEATURES OR SURFACES INTERACTIVE WITH THE USER, ELECTRICAL CONTROLLING DEVICES FOR SCULPTURED OR TEXTURED WALLS, FLOORS OR PANELS HAVING A THERAPEUTIC EFFECT ON THE USER, ELECTRICAL CONTROLLING DEVICES FOR ROOMS, WALLS, FLOORS, PANELS OR OTHER STRUCTURES HAVING ILLUMINATION OR OTHER LIGHT EFFECTS, AIR FLOW OR AUDITORY EFFECTS FOR USE BY OR FOR THE TREATMENT OF CHILDREN AND ADULTS AND FOR ABLE BODIED, HANDICAPPED OR DISABLED PEOPLE, ELECTRICAL CONTROLLING DEVICES FOR GAMES, TOYS OR PLAYTHINGS, ELECTRICAL CONTROLLING DEVICES FOR SPORTS OR PLAY APPARATUS OR EQUIPMENT FOR USE BY THE PHYSICALLY OR MENTALLY IMPAIRED OR HANDICAPPED, ELECTRICAL CONTROLLING DEVICES FOR CONSTRUCTIONAL OR INTERACTIVE TOYS OR GAMES, ELECTRICAL CONTROLLING DEVICES FOR GAMES, TOYS OR PLAYTHINGS INCORPORATING SENSORY STIMULATION EFFECTS, ELECTRICAL CONTROLLING DEVICES FOR TACTILE, VISUAL, OLFACTORY OR AUDIO EFFECTS, ELECTRICAL CONTROLLING DEVICES FOR MANIPULATIVE TOYS, GAMES OR PLAYTHINGS, INTERACTIVE SWITCH BOXES FOR USE IN CONTROLLING MEDICAL AND THERAPEUTIC STRUCTURES, APPARATUS OR EQUIPMENT, SENSORY, TACTILE, VISUAL, ORAL OR MENTAL STIMULATION APPARATUS AND EQUIPMENT, INTERACTIVE ELECTRICAL CONTROLLING DEVICES THAT ARE TRIGGERED BY SOUND, MOVEMENT OR LIGHT FOR USE IN CONTROLLING MEDICAL AND THERAPEUTIC STRUCTURES, APPARATUS OR EQUIPMENT, SENSORY, TACTILE, VISUAL, ORAL OR MENTAL STIMULATION APPARATUS AND EQUIPMENT, FIBRE OPTIC APPARATUS, NAMELY, DECORATIVE FIBRE OPTIC LIGHTING AND PARTS AND ACCESSORIES THEREFORE, FIBRE OPTIC CABLES, PHOTOGRAPHIC PROJECTORS, COMPONENT PARTS AND COMPONENT FITTINGS FOR ELECTRICAL CONTROLLING DEVICES, COMPUTERS FOR SENSORY, TACTILE, VISUAL, AURAL OR MENTAL STIMULATION THAT ARE USED FOR EDUCATIONAL, INTERACTIVE, CALMING, THERAPEUTIC, AND/OR STIMULATORY PURPOSES, DOWNLOADABLE ELECTRONIC PUBLICATIONS IN THE FIELD OF OCCUPATIONAL THERAPY, MULTI-SENSORY DEVELOPMENT AND APPARATUS, EQUIPMENT AND TEACHING AIDS, MEDICAL AND THERAPEUTIC APPARATUS OR EQUIPMENT SPECIFICALLY FOR THERAPEUTIC USE, NAMELY, DEVICES FOR ROOMS, BOOTHS, FLOORS, WALL PANELS OR OTHER STRUCTURES HAVING ILLUMINATION OR OTHER LIGHT EFFECTS, AIRFLOW, OLFACTORY, VESTIBULAR, TACTILE, PROPRIOCEPTION OR AUDITORY OR OTHER SENSORY EFFECTS, MEDICAL APPARATUS AND EQUIPMENT SPECIFICALLY FOR THERAPEUTIC USE FOR CHILDREN AND ADULTS AND FOR THE ABLE BODIED, HANDICAPPED OR DISABLED HAVING A THERAPEUTIC OR STIMULATORY EFFECT ON THE USER, NAMELY, DEVICES FOR ROOMS, BOOTHS, FLOORS, WALL PANELS OR OTHER STRUCTURES HAVING ILLUMINATION OR OTHER LIGHT EFFECTS, AIRFLOW, OLFACTORY, VESTIBULAR, TACTILE, PROPRIOCEPTION OR AUDITORY OR OTHER SENSORY EFFECTS, COMPONENT PARTS AND COMPONENT FITTINGS FOR DEVICES FOR ROOMS, BOOTHS, FLOORS, WALL PANELS OR OTHER STRUCTURES HAVING ILLUMINATION OR OTHER LIGHT EFFECTS, AIRFLOW, OLFACTORY, VESTIBULAR, TACTILE, PROPRIOCEPTION OR AUDITORY OR OTHER SEN-

SORY EFFECTS, SENSORY, TACTILE, VISUAL, AURAL OR MENTAL STIMULATION APPARATUS AND EQUIPMENT BEING ELECTRICAL APPARATUS AND EQUIPMENT USED FOR EDUCATIONAL, INTERACTIVE, CALMING, THERAPEUTIC AND/OR STIMULATORY PURPOSES, NAMELY, DEVICES FOR ROOMS, BOOTHS, FLOORS, WALL PANELS OR OTHER STRUCTURES HAVING ILLUMINATION OR OTHER LIGHT EFFECTS, AIRFLOW, OLFACTORY, VESTIBULAR, TACTILE, PROPRIOCEPTION OR AUDITORY EFFECTS, GYMNASIAC AND SPORTING EQUIPMENT AND APPARATUS FOR USE BY PEOPLE WITH PHYSICAL AND/OR MENTAL DISABILITIES, NAMELY, TRAMPOLINES, SWINGS, BOLSTERS, AND OTHER APPARATUS AND EQUIPMENT FOR SENSORY INTEGRATION, GAMES, TOYS AND PLAYTHINGS, NAMELY, ACTION SKILL GAMES, CAUSE AND EFFECT TOYS, MULTIPLE SKILL ACTIVITY TOYS, DEVELOPMENT AND ASSESSMENT GAMES, TOYS AND PLAYTHINGS, TRAMPOLINES, SWINGS, BOLSTERS, AND OTHER GOODS AND SERVICES, APPARATUS AND EQUIPMENT FOR SENSORY INTEGRATION, COMPONENT PARTS AND COMPONENT FITTINGS FOR ACTION SKILL GAMES, MULTIPLE SKILL ACTIVITY TOYS, DEVELOPMENT AND ASSESSMENT GAMES, TOYS AND PLAYTHINGS, TRAMPOLINES, SWINGS, BOLSTERS, AND OTHER APPARATUS AND EQUIPMENT FOR SENSORY INTEGRATION, LIGHTING APPARATUS AND EQUIPMENT, NAMELY, LIGHT PROJECTORS, LIGHT EMITTING DIODES PRODUCING A RANGE OF LIGHTING EFFECTS, LIGHTING APPARATUS DESIGNED TO STIMULATE THE VISUAL SENSES, NAMELY, LIGHT PROJECTORS, LIGHT EMITTING DIODES PRODUCING A RANGE OF LIGHTING EFFECTS, LIGHTING APPARATUS INCORPORATING OPTICAL FIBBERS, NAMELY, LIGHT PROJECTORS, LIGHT EMITTING DIODES PRODUCING A RANGE OF LIGHTING EFFECTS, LIGHTING TUBES, LIGHTING TUBES, NAMELY, ILLUMINATED BUBBLE TUBES, COMPONENT PARTS AND COMPONENT FITTINGS FOR LIGHT PROJECTORS, LIGHT EMITTING DIODES PRODUCING A RANGE OF LIGHTING EFFECTS, PUBLICATIONS, NAMELY, BROCHURES, BOOKLETS, AND TEACHING MATERIALS IN THE FIELD OF OCCUPATIONAL THERAPY, MULTI-SENSORY DEVELOPMENT AND APPARATUS, EQUIPMENT AND TEACHING AIDS, INSTRUCTIONAL AND TEACHING MATERIALS IN THE FIELD OF OCCUPATIONAL THERAPY, MULTI-SENSORY DEVELOPMENT AND APPARATUS, EQUIPMENT AND TEACHING AIDS, INSTRUCTIONAL AND TEACHING WRITING INSTRUMENTS, STATIONERY, WRITING INSTRUMENTS, PERIODICALS IN THE FIELD OF OCCUPATIONAL THERAPY, MULTI-SENSORY DEVELOPMENT AND APPARATUS, EQUIPMENT AND TEACHING AIDS, BOOKS IN THE FIELD OF OCCUPATIONAL THERAPY, MULTI-SENSORY DEVELOPMENT AND APPARATUS, EQUIPMENT AND TEACHING AIDS, SOFTWARE PROGRAMMES AND DATA PROCESSING PROGRAMS IN PRINTED FORM, PUBLICATIONS IN THE FIELD OF OCCUPATIONAL THERAPY, MULTI-SENSORY DEVELOPMENT AND APPARATUS, EQUIPMENT AND TEACHING AIDS, CATALOGS IN THE FIELD OF OCCUPATIONAL THERAPY, MULTI-SENSORY DEVELOPMENT AND APPARATUS, EQUIPMENT AND TEACHING AIDS, PREFABRICATED NON-METAL BUILDINGS COMPRISING ROOMS, BOOTHS, FLOORS, WALLS, PANELS OR OTHER STRUCTURES HAVING FEATURES OR SURFACES INTERACTIVE WITH THE USER, OR COMPRISING SCULPTURED OR TEXTURED WALLS, FLOORS OR PANELS HAVING A GENERALLY THERAPEUTIC EFFECT ON THE USER, PREFABRICATED NON-METAL BUILDINGS COMPRISING ROOMS, WALLS, FLOORS, PANELS OR OTHER STRUCTURES HAVING ILLUMINATION, OR OTHER LIGHT EFFECTS, AIR FLOW OR AUDITORY EFFECTS AND HAVING A GENERALLY THERAPEUTIC EFFECT ON CHILDREN, ADULTS, THE ABLE BODIED, HANDICAPPED OR DISABLED PEOPLE, GAMES, TOYS AND PLAYTHINGS, NAMELY, ACTION SKILL GAMES, CAUSE AND EFFECT TOYS, MULTIPLE SKILL ACTIVITY TOYS, VISUAL STIMULATION GAMES, TOYS AND PLAYTHINGS, TACTILE FEEDBACK GAMES, TOYS AND PLAYTHINGS, AUDITORY FEEDBACK GAMES, TOYS AND PLAYTHINGS, TRACKING GAMES, TOYS AND PLAYTHINGS, MOTOR SKILLS GAMES, TOYS

AND PLAYTHINGS, DEVELOPMENT AND ASSESSMENT GAMES, TOYS AND PLAYTHINGS, CONSTRUCTIONAL OR INTERACTIVE TOYS, GAMES AND PLAYTHINGS, NAMELY, ACTION SKILL GAMES, CAUSE AND EFFECT TOYS, MULTIPLE SKILL ACTIVITY TOYS, VISUAL STIMULATION GAMES, TOYS AND PLAYTHINGS, TACTILE FEEDBACK GAMES, TOYS AND PLAYTHINGS, AUDITORY FEEDBACK GAMES, TOYS AND PLAYTHINGS, TRACKING GAMES, TOYS AND PLAYTHINGS; MOTOR SKILLS GAMES, TOYS AND PLAYTHINGS, DEVELOPMENT AND ASSESSMENT GAMES, TOYS AND PLAYTHINGS, GAMES, TOYS AND PLAYTHINGS DESIGNED TO STIMULATE THE SENSES, NAMELY, ACTION SKILL GAMES, CAUSE AND EFFECT TOYS, MULTIPLE SKILL ACTIVITY TOYS, VISUAL STIMULATION GAMES, TOYS AND PLAYTHINGS, TACTILE FEEDBACK GAMES, TOYS AND PLAYTHINGS, AUDITORY FEEDBACK GAMES, TOYS AND PLAYTHINGS, TRACKING GAMES, TOYS AND PLAYTHINGS, MOTOR SKILLS GAMES, TOYS AND PLAYTHINGS, DEVELOPMENT AND ASSESSMENT GAMES, TOYS AND PLAYTHINGS, TACTILE, MANIPULATIVE TOYS, GAMES OR PLAYTHINGS, NAMELY, ACTION SKILL GAMES, CAUSE AND EFFECT TOYS, MULTIPLE SKILL ACTIVITY TOYS, VISUAL STIMULATION GAMES, TOYS AND PLAYTHINGS, TACTILE FEEDBACK GAMES, TOYS AND PLAYTHINGS, AUDITORY FEEDBACK GAMES, TOYS AND PLAYTHINGS, TRACKING GAMES, TOYS AND PLAYTHINGS, MOTOR SKILLS GAMES, TOYS AND PLAYTHINGS, DEVELOPMENT AND ASSESSMENT GAMES, TOYS AND PLAYTHINGS (U.S. CLS. 100, 101 AND 102).

#### **CLASS 41—EDUCATION AND ENTERTAINMENT**

FOR EDUCATION SERVICES, NAMELY, THE PROVISION OF WORKSHOPS, SEMINARS, LECTURES AND ONLINE TUTORIAL SESSIONS IN THE FIELD OF OCCUPATIONAL THERAPY, AND MULTI-SENSORY DEVELOPMENT, AND OCCUPATIONAL THERAPY AND MULTI-SENSORY APPARATUS, EQUIPMENT AND TEACHING AIDS; ARRANGING OF SEMINARS FOR EDUCATIONAL PURPOSES; PROVIDING TRAINING SERVICES IN THE FIELD OF OCCUPATIONAL THERAPY, AND MULTI-SENSORY DEVELOPMENT, AND OCCUPATIONAL THERAPY AND MULTI-SENSORY APPARATUS, EQUIPMENT, TEACHING AIDS; TEACHING IN THE FIELD OF OCCUPATIONAL THERAPY, AND MULTI-SENSORY DEVELOPMENT, AND OCCUPATIONAL THERAPY AND MULTI-SENSORY APPARATUS AND EQUIPMENT AND TEACHING AIDS; ENTERTAINMENT SERVICES IN THE FIELD OF OCCUPATIONAL THERAPY, AND MULTI-SENSORY DEVELOPMENT, AND OCCUPATIONAL THERAPY AND MULTI-SENSORY APPARATUS AND EQUIPMENT, TEACHING AIDS; PROVIDING A WEBSITE FEATURING NON-DOWNLOADABLE EDUCATIONAL TEACHING MATERIALS; CONSULTANCY IN THE FIELD OF EDUCATIONAL TRAINING IN THE FIELD OF OCCUPATIONAL THERAPY AND MULTI-SENSORY DEVELOPMENT APPARATUS, TEACHING AIDS (U.S. CLS. 100, 101 AND 107).

KAREN K. BUSH, EXAMINING ATTORNEY

SN 77-677,363. JONES, MR. GARETH ALEXIS WATSON, NORTH YORKSHIRE, UNITED KINGDOM, FILED 2-24-2009.

### **M.I.L.E. - MULTI SENSORY INTERACTIVE LEARNING ENVIRONMENT**

THE MARK CONSISTS OF STANDARD CHARACTERS WITHOUT CLAIM TO ANY PARTICULAR FONT, STYLE, SIZE, OR COLOR.

PRIORITY CLAIMED UNDER SEC. 44(D) ON ERPNTY TM OFC APPLICATION NO. 007199722, FILED 8-28-2008, REG. NO. 007199722, DATED 2-22-2010, EXPIRES 8-28-2018.

NO CLAIM IS MADE TO THE EXCLUSIVE RIGHT TO USE "MULTI SENSORY INTERACTIVE LEARNING ENVIRONMENT", APART FROM THE MARK AS SHOWN.

#### **CLASS 9—ELECTRICAL AND SCIENTIFIC APPARATUS**

FOR ELECTRICAL CONTROLLING DEVICES FOR MEDICAL AND THERAPEUTIC STRUCTURES, APPARATUS OR EQUIPMENT; ELECTRICAL CONTROLLING DEVICES FOR SENSORY, TACTILE, VISUAL, ORAL OR MENTAL STIMULATION APPARATUS AND EQUIPMENT; ELECTRICAL CONTROLLING DEVICES FOR APPARATUS, EQUIPMENT, STRUCTURES, GAMES, TOYS AND PLAYTHINGS THAT IS USED WITH CHILDREN, ADULTS, THE ABLE BODIED, HANDICAPPED OR DISABLED HAVING A THERAPEUTIC OR STIMULATORY EFFECT ON THE USER; ELECTRICAL CONTROLLING DEVICES FOR ROOMS, BOOTHS, FLOORS, WALL PANELS OR OTHER STRUCTURES HAVING FEATURES OR SURFACES INTERACTIVE WITH THE USER; ELECTRICAL CONTROLLING DEVICES FOR SCULPTURED OR TEXTURED WALLS, FLOORS OR PANELS HAVING A THERAPEUTIC EFFECT ON THE USER; ELECTRICAL CONTROLLING DEVICES FOR ROOMS, WALLS, FLOORS, PANELS OR OTHER STRUCTURES HAVING ILLUMINATION OR OTHER LIGHT EFFECTS, AIR FLOW OR AUDITORY EFFECTS FOR USE BY OR FOR THE TREATMENT OF CHILDREN AND ADULTS AND FOR ABLE BODIED, HANDICAPPED OR DISABLED PEOPLE; ELECTRICAL CONTROLLING DEVICES FOR GAMES, TOYS OR PLAYTHINGS; ELECTRICAL CONTROLLING DEVICES FOR SPORTS OR PLAY APPARATUS OR EQUIPMENT FOR USE BY THE PHYSICALLY OR MENTALLY IMPAIRED OR HANDICAPPED; ELECTRICAL CONTROLLING DEVICES FOR CONSTRUCTIONAL OR INTERACTIVE TOYS OR GAMES; ELECTRICAL CONTROLLING DEVICES FOR GAMES, TOYS OR PLAYTHINGS INCORPORATING SENSORY STIMULATION EFFECTS; ELECTRICAL CONTROLLING DEVICES FOR TACTILE, VISUAL, OLFACTORY OR AUDIO EFFECTS; ELECTRICAL CONTROLLING DEVICES FOR MANIPULATIVE TOYS, GAMES OR PLAYTHINGS; INTERACTIVE SWITCH BOXES FOR USE IN CONTROLLING MEDICAL AND THERAPEUTIC STRUCTURES, APPARATUS OR EQUIPMENT, SENSORY, TACTILE, VISUAL, ORAL OR MENTAL STIMULATION APPARATUS AND EQUIPMENT; INTERACTIVE ELECTRICAL CONTROLLING DEVICES THAT ARE TRIGGERED BY SOUND, MOVEMENT OR LIGHT FOR USE IN CONTROLLING MEDICAL AND THERAPEUTIC STRUCTURES, APPARATUS OR EQUIPMENT, SENSORY, TACTILE, VISUAL, ORAL OR MENTAL STIMULATION APPARATUS AND EQUIPMENT; FIBER OPTIC CABLES; PHOTOGRAPHIC PROJECTORS; COMPONENT PARTS AND COMPONENT FITTINGS FOR ELECTRICAL CONTROLLING DEVICES; COMPUTERS FOR SENSORY, TACTILE, VISUAL, AURAL OR MENTAL STIMULATION THAT ARE USED FOR EDUCATIONAL, INTERACTIVE, CALMING, THERAPEUTIC, AND/OR STIMULATORY PURPOSES; DOWNLOADABLE ELECTRONIC PUBLICATIONS IN THE NATURE OF NEWSLETTERS, CATALOGUES, BROCHURES, E-BOOKS, TEACHING MATERIALS IN THE FIELD OF OCCUPATIONAL THERAPY AND MULTI-SENSORY DEVELOPMENT AND IN THE FIELD OF OCCUPATIONAL THERAPY AND MULTI-SENSORY DEVELOPMENT APPARATUS, EQUIPMENT AND TEACHING AIDS; DOWNLOADABLE SOFTWARE IN THE FIELD OF OCCUPATIONAL THERAPY AND MULTI-SENSORY DEVELOPMENT AND IN THE FIELD OF OCCUPATIONAL THERAPY AND MULTI-SENSORY DEVELOPMENT APPARATUS, TEACHING AIDS (U.S. CLS. 21, 23, 26, 36 AND 38).

**CLASS 10—MEDICAL APPARATUS**

FOR MEDICAL AND THERAPEUTIC APPARATUS OR EQUIPMENT SPECIFICALLY FOR THERAPEUTIC USE, NAMELY, DEVICES FOR ROOMS, BOOTHS, FLOORS, WALL PANELS OR OTHER STRUCTURES HAVING ILLUMINATION OR OTHER LIGHT EFFECTS, AIRFLOW, OLFACTORY, VESTIBULAR, TACTILE, PROPRIOCEPTION OR AUDITORY OR OTHER SENSORY EFFECTS; MEDICAL APPARATUS AND EQUIPMENT SPECIFICALLY FOR THERAPEUTIC USE FOR CHILDREN AND ADULTS AND FOR THE ABLE BODIED, HANDICAPPED OR DISABLED HAVING A THERAPEUTIC OR STIMULATORY EFFECT ON THE USER, NAMELY, DEVICES FOR ROOMS, BOOTHS, FLOORS, WALL PANELS OR OTHER STRUCTURES HAVING ILLUMINATION OR OTHER LIGHT EFFECTS, AIRFLOW, OLFACTORY, VESTIBULAR, TACTILE, PROPRIOCEPTION OR AUDITORY OR OTHER SENSORY EFFECTS; COMPONENT PARTS AND COMPONENT FITTINGS FOR MEDICAL AND THERAPEUTIC APPARATUS OR EQUIPMENT SPECIFICALLY FOR THERAPEUTIC USE IN ROOMS, BOOTHS, FLOORS, WALL PANELS OR OTHER STRUCTURES HAVING ILLUMINATION OR OTHER LIGHT EFFECTS, AIRFLOW, OLFACTORY, VESTIBULAR, TACTILE, PROPRIOCEPTION OR AUDITORY OR OTHER SENSORY EFFECTS; SENSORY, TACTILE, VISUAL, AURAL OR MENTAL STIMULATION APPARATUS AND EQUIPMENT BEING ELECTRICAL MEDICAL AND THERAPEUTIC APPARATUS OR EQUIPMENT SPECIFICALLY FOR THERAPEUTIC USE FOR EDUCATIONAL, INTERACTIVE, CALMING, THERAPEUTIC AND/OR STIMULATORY PURPOSES FOR USE IN ROOMS, BOOTHS, FLOORS, WALL PANELS OR OTHER STRUCTURES HAVING ILLUMINATION OR OTHER LIGHT EFFECTS, AIRFLOW, OLFACTORY, VESTIBULAR, TACTILE, PROPRIOCEPTION OR AUDITORY EFFECTS; MEDICAL AND THERAPEUTIC APPARATUS OR EQUIPMENT SPECIFICALLY FOR THERAPEUTIC USE FOR GYMNASIAC AND SPORTING USE BY PEOPLE WITH PHYSICAL AND/OR MENTAL DISABILITIES, NAMELY, MEDICAL AND THERAPEUTIC USE TRAMPOLINES, SWINGS, BOLSTERS, AND THERAPEUTIC APPARATUS FOR SENSORY INTEGRATION; MEDICAL AND THERAPEUTIC APPARATUS OR EQUIPMENT SPECIFICALLY FOR THERAPEUTIC USE IN THE NATURE OF THERAPEUTIC USE ACTION SKILL GAMES, CAUSE AND EFFECT TOYS, MULTIPLE SKILL ACTIVITY TOYS, DEVELOPMENT AND ASSESSMENT GAMES, TOYS AND PLAYTHINGS, TRAMPOLINES, SWINGS, BOLSTERS, AND OTHER THERAPEUTIC APPARATUS AND EQUIPMENT FOR SENSORY INTEGRATION; COMPONENT PARTS AND COMPONENT FITTINGS FOR MEDICAL AND THERAPEUTIC APPARATUS OR EQUIPMENT SPECIFICALLY FOR THERAPEUTIC USE IN THE NATURE OF THERAPEUTIC USE ACTION SKILL GAMES, MULTIPLE SKILL ACTIVITY TOYS, DEVELOPMENT AND ASSESSMENT GAMES, TOYS AND PLAYTHINGS, TRAMPOLINES, SWINGS, BOLSTERS, AND OTHER GOODS AND OTHER THERAPEUTIC USE APPARATUS AND EQUIPMENT FOR SENSORY INTEGRATION (U.S. CLS. 26, 39 AND 44).

**CLASS 11—ENVIRONMENTAL CONTROL APPARATUS**

FOR ELECTRIC LIGHTING FIXTURES, NAMELY, PROJECTOR LAMPS, LED (LIGHT EMITTING DIODE) LIGHTING FIXTURES PRODUCING A RANGE OF LIGHTING EFFECTS; ELECTRIC LIGHTING FIXTURES INCORPORATING OPTICAL FIBERS, NAMELY, PROJECTOR LAMPS, LED (LIGHT EMITTING DIODE) LIGHTING FIXTURES PRODUCING A RANGE OF LIGHTING EFFECTS; LIGHTING TUBES; LIGHTING TUBES, NAMELY, ILLUMINATED BUBBLE TUBES; COMPONENT PARTS AND COMPONENT FITTINGS FOR PROJECTOR LAMPS, LED (LIGHT EMITTING DIODE) LIGHTING FIXTURES (U.S. CLS. 13, 21, 23, 31 AND 34).

**CLASS 16—PAPER GOODS AND PRINTED MATTER**

FOR PUBLICATIONS, NAMELY, BROCHURES, BOOKLETS, AND TEACHING MATERIALS IN THE FIELD OF OCCUPATIONAL THERAPY AND MULTI-SENSORY DEVELOPMENT AND IN THE FIELD OF OCCUPATIONAL THERAPY AND MULTI-SENSORY DEVELOPMENT APPARATUS, EQUIPMENT AND TEACHING AIDS; INSTRUCTIONAL AND TEACHING MATERIALS IN THE FIELD OF OCCUPATIONAL THERAPY AND MULTI-SENSORY DEVELOPMENT AND IN THE FIELD OF OCCUPATIONAL THERAPY AND MULTI-SENSORY DEVELOPMENT APPARATUS, EQUIPMENT AND TEACHING AIDS; INSTRUCTIONAL AND TEACHING WRITING INSTRUMENTS; STATIONERY, WRITING INSTRUMENTS; PERIODICALS IN THE FIELD OF OCCUPATIONAL THERAPY AND MULTI-SENSORY DEVELOPMENT AND IN THE FIELD OF OCCUPATIONAL THERAPY AND MULTI-SENSORY DEVELOPMENT APPARATUS, EQUIPMENT AND TEACHING AIDS; BOOKS IN THE FIELD OF OCCUPATIONAL THERAPY AND MULTI-SENSORY DEVELOPMENT AND IN THE FIELD OF OCCUPATIONAL THERAPY AND MULTI-SENSORY DEVELOPMENT APPARATUS, EQUIPMENT AND TEACHING AIDS; NOTEBOOKS; MAGAZINES IN THE FIELD OF OCCUPATIONAL THERAPY AND MULTI-SENSORY DEVELOPMENT AND IN THE FIELD OF OCCUPATIONAL THERAPY AND MULTI-SENSORY DEVELOPMENT APPARATUS, EQUIPMENT AND TEACHING AIDS; CATALOGS IN THE FIELD OF OCCUPATIONAL THERAPY AND MULTI-SENSORY DEVELOPMENT AND IN THE FIELD OF OCCUPATIONAL THERAPY AND MULTI-SENSORY DEVELOPMENT APPARATUS, EQUIPMENT AND TEACHING AIDS; SOFTWARE PROGRAMS AND DATA PROCESSING PROGRAMS IN PRINTED FORM; PUBLICATIONS, NAMELY, NEWSLETTERS, CATALOGUES, BROCHURES, BOOKLETS AND TEACHING MATERIALS IN THE FIELD OF OCCUPATIONAL THERAPY AND MULTI-SENSORY DEVELOPMENT AND MULTI-SENSORY DEVELOPMENT APPARATUS, EQUIPMENT AND TEACHING AIDS (U.S. CLS. 2, 5, 22, 23, 29, 37, 38 AND 50).

**CLASS 19—NON-METALLIC BUILDING MATERIALS**

FOR PREFABRICATED NON-METAL BUILDINGS COMPRISING ROOMS, BOOTHS, FLOORS, WALLS, PANELS OR OTHER STRUCTURES HAVING FEATURES OR SURFACES INTERACTIVE WITH THE USER, OR COMPRISING SCULPTURED OR TEXTURED WALLS, FLOORS OR PANELS HAVING A GENERALLY THERAPEUTIC EFFECT ON THE USER; PREFABRICATED NON-METAL BUILDINGS COMPRISING ROOMS, WALLS, FLOORS, PANELS OR OTHER STRUCTURES HAVING ILLUMINATION, OR OTHER LIGHT EFFECTS, AIR FLOW OR AUDITORY EFFECTS AND HAVING A GENERALLY THERAPEUTIC EFFECT ON CHILDREN, ADULTS, THE ABLE BODIED, HANDICAPPED OR DISABLED PEOPLE (U.S. CLS. 1, 12, 33 AND 50).

**CLASS 35—ADVERTISING AND BUSINESS**

FOR THE BRINGING TOGETHER, FOR THE BENEFIT OF OTHERS, OF A VARIETY OF GOODS ENABLING CUSTOMERS TO CONVENIENTLY VIEW AND PURCHASE THOSE GOODS IN THE FIELD OF ELECTRICAL CONTROLLING DEVICES FOR MEDICAL AND THERAPEUTIC STRUCTURES, APPARATUS OR EQUIPMENT, ELECTRICAL CONTROLLING DEVICES FOR SENSORY, TACTILE, VISUAL, ORAL OR MENTAL STIMULATION APPARATUS AND EQUIPMENT, ELECTRICAL CONTROLLING DEVICES FOR APPARATUS, EQUIPMENT, STRUCTURES, GAMES, TOYS AND PLAYTHINGS THAT IS USED WITH CHILDREN, ADULTS, THE ABLE BODIED, HANDICAPPED OR DISABLED HAVING A THERAPEUTIC OR STIMULATORY EFFECT ON THE USER, ELECTRICAL CONTROLLING DEVICES FOR ROOMS, BOOTHS, FLOORS, WALL PANELS OR OTHER STRUCTURES HAVING FEATURES OR SURFACES INTERACTIVE WITH THE USER, ELECTRICAL CONTROLLING DEVICES FOR SCULPTURED OR TEXTURED WALLS, FLOORS OR PANELS HAVING A THERAPEUTIC EFFECT ON THE



USER, ELECTRICAL CONTROLLING DEVICES FOR ROOMS, WALLS, FLOORS, PANELS OR OTHER STRUCTURES HAVING ILLUMINATION OR OTHER LIGHT EFFECTS, AIR FLOW OR AUDITORY EFFECTS FOR USE BY OR FOR THE TREATMENT OF CHILDREN AND ADULTS AND FOR ABLE BODIED, HANDICAPPED OR DISABLED PEOPLE, ELECTRICAL CONTROLLING DEVICES FOR GAMES, TOYS OR PLAYTHINGS, ELECTRICAL CONTROLLING DEVICES FOR SPORTS OR PLAY APPARATUS OR EQUIPMENT FOR USE BY THE PHYSICALLY OR MENTALLY IMPAIRED OR HANDICAPPED, ELECTRICAL CONTROLLING DEVICES FOR CONSTRUCTIONAL OR INTERACTIVE TOYS OR GAMES, ELECTRICAL CONTROLLING DEVICES FOR GAMES, TOYS OR PLAYTHINGS INCORPORATING SENSORY STIMULATION EFFECTS, ELECTRICAL CONTROLLING DEVICES FOR TACTILE, VISUAL, OLFACTORY OR AUDIO EFFECTS, ELECTRICAL CONTROLLING DEVICES FOR MANIPULATIVE TOYS, GAMES OR PLAYTHINGS, INTERACTIVE SWITCH BOXES FOR USE IN CONTROLLING MEDICAL AND THERAPEUTIC STRUCTURES, APPARATUS OR EQUIPMENT, SENSORY, TACTILE, VISUAL, ORAL OR MENTAL STIMULATION APPARATUS AND EQUIPMENT, INTERACTIVE ELECTRICAL CONTROLLING DEVICES THAT ARE TRIGGERED BY SOUND, MOVEMENT OR LIGHT FOR USE IN CONTROLLING MEDICAL AND THERAPEUTIC STRUCTURES, APPARATUS OR EQUIPMENT, SENSORY, TACTILE, VISUAL, ORAL OR MENTAL STIMULATION APPARATUS AND EQUIPMENT, FIBRE OPTIC APPARATUS, NAMELY, DECORATIVE FIBRE OPTIC LIGHTING AND PARTS AND ACCESSORIES THEREFOR, FIBRE OPTIC CABLES, PHOTOGRAPHIC PROJECTORS, COMPONENT PARTS AND COMPONENT FITTINGS FOR ELECTRICAL CONTROLLING DEVICES, COMPUTERS FOR SENSORY, TACTILE, VISUAL, AURAL OR MENTAL STIMULATION THAT ARE USED FOR EDUCATIONAL, INTERACTIVE, CALMING, THERAPEUTIC, AND/OR STIMULATORY PURPOSES, DOWNLOADABLE ELECTRONIC PUBLICATIONS IN THE FIELD OF OCCUPATIONAL THERAPY, MULTI-SENSORY DEVELOPMENT AND APPARATUS, EQUIPMENT AND TEACHING AIDS, MEDICAL AND THERAPEUTIC APPARATUS OR EQUIPMENT SPECIFICALLY FOR THERAPEUTIC USE, NAMELY, DEVICES FOR ROOMS, BOOTHS, FLOORS, WALL PANELS OR OTHER STRUCTURES HAVING ILLUMINATION OR OTHER LIGHT EFFECTS, AIRFLOW, OLFACTORY, VESTIBULAR, TACTILE, PROPRIOCEPTION OR AUDITORY OR OTHER SENSORY EFFECTS, MEDICAL APPARATUS AND EQUIPMENT SPECIFICALLY FOR THERAPEUTIC USE FOR CHILDREN AND ADULTS AND FOR THE ABLE BODIED, HANDICAPPED OR DISABLED HAVING A THERAPEUTIC OR STIMULATORY EFFECT ON THE USER, NAMELY, DEVICES FOR ROOMS, BOOTHS, FLOORS, WALL PANELS OR OTHER STRUCTURES HAVING ILLUMINATION OR OTHER LIGHT EFFECTS, AIRFLOW, OLFACTORY, VESTIBULAR, TACTILE, PROPRIOCEPTION OR AUDITORY OR OTHER SENSORY EFFECTS, COMPONENT PARTS AND COMPONENT FITTINGS FOR DEVICES FOR ROOMS, BOOTHS, FLOORS, WALL PANELS OR OTHER STRUCTURES HAVING ILLUMINATION OR OTHER LIGHT EFFECTS, AIRFLOW, OLFACTORY, VESTIBULAR, TACTILE, PROPRIOCEPTION OR AUDITORY OR OTHER SENSORY EFFECTS, SENSORY, TACTILE, VISUAL, AURAL OR MENTAL STIMULATION APPARATUS AND EQUIPMENT BEING ELECTRICAL APPARATUS AND EQUIPMENT USED FOR EDUCATIONAL, INTERACTIVE, CALMING, THERAPEUTIC AND/OR STIMULATORY PURPOSES, NAMELY, DEVICES FOR ROOMS, BOOTHS, FLOORS, WALL PANELS OR OTHER STRUCTURES HAVING ILLUMINATION OR OTHER LIGHT EFFECTS, AIRFLOW, OLFACTORY, VESTIBULAR, TACTILE, PROPRIOCEPTION OR AUDITORY EFFECTS, GYMNASIAC AND SPORTING EQUIPMENT AND APPARATUS FOR USE BY PEOPLE WITH PHYSICAL AND/OR MENTAL DISABILITIES, NAMELY, TRAMPOLINES, SWINGS, BOLSTERS, AND OTHER APPARATUS AND EQUIPMENT FOR SENSORY INTEGRATION, GAMES, TOYS AND PLAYTHINGS, NAMELY, ACTION SKILL GAMES, CAUSE AND EFFECT TOYS, MULTIPLE SKILL ACTIVITY TOYS, DEVELOPMENT AND ASSESSMENT GAMES, TOYS AND PLAYTHINGS, TRAMPOLINES, SWINGS, BOLSTERS, AND OTHER GOODS AND SERVICES, APPARATUS AND EQUIPMENT FOR SENSORY INTEGRATION, COMPONENT PARTS AND COMPONENT FITTINGS FOR ACTION SKILL GAMES, MULTI-

PLE SKILL ACTIVITY TOYS, DEVELOPMENT AND ASSESSMENT GAMES, TOYS AND PLAYTHINGS, TRAMPOLINES, SWINGS, BOLSTERS, AND OTHER APPARATUS AND EQUIPMENT FOR SENSORY INTEGRATION, LIGHTING APPARATUS AND EQUIPMENT, NAMELY, LIGHT PROJECTORS, LIGHT EMITTING DIODES PRODUCING A RANGE OF LIGHTING EFFECTS, LIGHTING APPARATUS DESIGNED TO STIMULATE THE VISUAL SENSES, NAMELY, LIGHT PROJECTORS, LIGHT EMITTING DIODES PRODUCING A RANGE OF LIGHTING EFFECTS, LIGHTING APPARATUS INCORPORATING OPTICAL FIBBERS, NAMELY, LIGHT PROJECTORS, LIGHT EMITTING DIODES PRODUCING A RANGE OF LIGHTING EFFECTS, LIGHTING TUBES, LIGHTING TUBES, NAMELY, ILLUMINATED BUBBLE TUBES, COMPONENT PARTS AND COMPONENT FITTINGS FOR LIGHT PROJECTORS, LIGHT EMITTING DIODES PRODUCING A RANGE OF LIGHTING EFFECTS, PUBLICATIONS, NAMELY, BROCHURES, BOOKLETS, AND TEACHING MATERIALS IN THE FIELD OF OCCUPATIONAL THERAPY, MULTI-SENSORY DEVELOPMENT AND APPARATUS, EQUIPMENT AND TEACHING AIDS, INSTRUCTIONAL AND TEACHING MATERIALS IN THE FIELD OF OCCUPATIONAL THERAPY, MULTI-SENSORY DEVELOPMENT AND APPARATUS, EQUIPMENT AND TEACHING AIDS, INSTRUCTIONAL AND TEACHING WRITING INSTRUMENTS, STATIONERY, WRITING INSTRUMENTS, PERIODICALS IN THE FIELD OF OCCUPATIONAL THERAPY, MULTI-SENSORY DEVELOPMENT AND APPARATUS, EQUIPMENT AND TEACHING AIDS, BOOKS IN THE FIELD OF OCCUPATIONAL THERAPY, MULTI-SENSORY DEVELOPMENT AND APPARATUS, EQUIPMENT AND TEACHING AIDS, NOTEBOOKS, MAGAZINES IN THE FIELD OF OCCUPATIONAL THERAPY, MULTI-SENSORY DEVELOPMENT AND APPARATUS, EQUIPMENT AND TEACHING AIDS, CATALOGS IN THE FIELD OF OCCUPATIONAL THERAPY, MULTI-SENSORY DEVELOPMENT AND APPARATUS, EQUIPMENT AND TEACHING AIDS, SOFTWARE PROGRAMMES AND DATA PROCESSING PROGRAMS IN PRINTED FORM, PUBLICATIONS IN THE FIELD OF OCCUPATIONAL THERAPY, MULTI-SENSORY DEVELOPMENT AND APPARATUS, EQUIPMENT AND TEACHING AIDS, PREFABRICATED NON-METAL BUILDINGS COMPRISING ROOMS, BOOTHS, FLOORS, WALLS, PANELS OR OTHER STRUCTURES HAVING FEATURES OR SURFACES INTERACTIVE WITH THE USER, OR COMPRISING SCULPTURED OR TEXTURED WALLS, FLOORS OR PANELS HAVING A GENERALLY THERAPEUTIC EFFECT ON THE USER, PREFABRICATED NON-METAL BUILDINGS COMPRISING ROOMS, WALLS, FLOORS, PANELS OR OTHER STRUCTURES HAVING ILLUMINATION, OR OTHER LIGHT EFFECTS, AIR FLOW OR AUDITORY EFFECTS AND HAVING A GENERALLY THERAPEUTIC EFFECT ON CHILDREN, ADULTS, THE ABLE BODIED, HANDICAPPED OR DISABLED PEOPLE, GAMES, TOYS AND PLAYTHINGS, NAMELY, ACTION SKILL GAMES, CAUSE AND EFFECT TOYS, MULTIPLE SKILL ACTIVITY TOYS, VISUAL STIMULATION GAMES, TOYS AND PLAYTHINGS, TACTILE FEEDBACK GAMES, TOYS AND PLAYTHINGS, AUDITORY FEEDBACK GAMES, TOYS AND PLAYTHINGS, TRACKING GAMES, TOYS AND PLAYTHINGS, MOTOR SKILLS GAMES, TOYS AND PLAYTHINGS, DEVELOPMENT AND ASSESSMENT GAMES, TOYS AND PLAYTHINGS, CONSTRUCTIONAL OR INTERACTIVE TOYS, GAMES AND PLAYTHINGS, NAMELY, ACTION SKILL GAMES, CAUSE AND EFFECT TOYS, MULTIPLE SKILL ACTIVITY TOYS, VISUAL STIMULATION GAMES, TOYS AND PLAYTHINGS, TACTILE FEEDBACK GAMES, TOYS AND PLAYTHINGS, AUDITORY FEEDBACK GAMES, TOYS AND PLAYTHINGS, TRACKING GAMES, TOYS AND PLAYTHINGS, MOTOR SKILLS GAMES, TOYS AND PLAYTHINGS, DEVELOPMENT AND ASSESSMENT GAMES, TOYS AND PLAYTHINGS, GAMES, TOYS AND PLAYTHINGS DESIGNED TO STIMULATE THE SENSES, NAMELY, ACTION SKILL GAMES, CAUSE AND EFFECT TOYS, MULTIPLE SKILL ACTIVITY TOYS, VISUAL STIMULATION GAMES, TOYS AND PLAYTHINGS, TACTILE FEEDBACK GAMES, TOYS AND PLAYTHINGS, AUDITORY FEEDBACK GAMES, TOYS AND PLAYTHINGS, TRACKING GAMES, TOYS AND PLAYTHINGS, MOTOR SKILLS GAMES, TOYS AND PLAYTHINGS, DEVELOPMENT AND ASSESSMENT GAMES, TOYS AND PLAYTHINGS, TACTILE, MANIPULATIVE TOYS, GAMES OR PLAYTHINGS,

NAMELY, ACTION SKILL GAMES, CAUSE AND EFFECT TOYS, MULTIPLE SKILL ACTIVITY TOYS, VISUAL STIMULATION GAMES, TOYS AND PLAYTHINGS, TACTILE FEEDBACK GAMES, TOYS AND PLAYTHINGS, AUDITORY FEEDBACK GAMES, TOYS AND PLAYTHINGS, TRACKING GAMES, TOYS AND PLAYTHINGS, MOTOR SKILLS GAMES, TOYS AND PLAYTHINGS, DEVELOPMENT AND ASSESSMENT GAMES, TOYS AND PLAYTHINGS (U.S. CLS. 100, 101 AND 102).

#### **CLASS 41—EDUCATION AND ENTERTAINMENT**

FOR EDUCATION SERVICES, NAMELY, THE PROVISION OF WORKSHOPS, SEMINARS, LECTURES AND ONLINE TUTORIAL SESSIONS IN THE FIELD OF OCCUPATIONAL THERAPY, AND MULTI-SENSORY DEVELOPMENT, AND OCCUPATIONAL THERAPY AND MULTI-SENSORY APPARATUS, EQUIPMENT AND TEACHING AIDS; ARRANGING OF SEMINARS FOR EDUCATIONAL PURPOSES; PROVIDING TRAINING SERVICES IN THE FIELD OF OCCUPATIONAL THERAPY, AND MULTI-SENSORY DEVELOPMENT, AND OCCUPATIONAL THERAPY AND MULTI-SENSORY APPARATUS, EQUIPMENT, TEACHING AIDS; TEACHING IN THE FIELD OF OCCUPATIONAL THERAPY, AND MULTI-SENSORY DEVELOPMENT, AND OCCUPATIONAL THERAPY AND MULTI-SENSORY APPARATUS AND EQUIPMENT AND TEACHING AIDS; ENTERTAINMENT SERVICES IN THE FIELD OF OCCUPATIONAL THERAPY, AND MULTI-SENSORY DEVELOPMENT, AND OCCUPATIONAL THERAPY AND MULTI-SENSORY APPARATUS AND EQUIPMENT, TEACHING AIDS; PROVIDING A WEBSITE FEATURING NON-DOWNLOADABLE EDUCATIONAL TEACHING MATERIALS; CONSULTANCY IN THE FIELD OF EDUCATIONAL TRAINING IN THE FIELD OF OCCUPATIONAL THERAPY AND MULTI-SENSORY DEVELOPMENT APPARATUS, TEACHING AIDS (U.S. CLS. 100, 101 AND 107).

KAREN K. BUSH, EXAMINING ATTORNEY

SN 77-683,892. YEVGENIY A VOSKOV, ASHLAND, MA. AND YEFIM G KACHKA, ASHLAND, MA. FILED 3-5-2009.



NO CLAIM IS MADE TO THE EXCLUSIVE RIGHT TO USE "LOUNGE", APART FROM THE MARK AS SHOWN.

THE COLOR(S) RED AND BLACK IS/ARE CLAIMED AS A FEATURE OF THE MARK.

THE MARK CONSISTS OF THE WORDS "AMSTERDAM LOUNGE" IN RED FONT WITH BLACK OUTLINING.

#### **CLASS 41—EDUCATION AND ENTERTAINMENT**

FOR HOOKAH LOUNGE SERVICES; NIGHT CLUBS; SMOKING LOUNGE SERVICES (U.S. CLS. 100, 101 AND 107).

FIRST USE 2-22-2009; IN COMMERCE 3-2-2009.

#### **CLASS 43—HOTEL AND RESTAURANT SERVICES**

FOR RESTAURANT, BAR AND CATERING SERVICES (U.S. CLS. 100 AND 101).

FIRST USE 2-22-2009; IN COMMERCE 3-2-2009.

LINDA MICKLEBURGH, EXAMINING ATTORNEY

SN 77-704,888. EXCHANGE-A-BLADE LTD., DELTA, B.C., CANADA, FILED 4-1-2009.

## **ECO-CENTER**

THE MARK CONSISTS OF STANDARD CHARACTERS WITHOUT CLAIM TO ANY PARTICULAR FONT, STYLE, SIZE, OR COLOR.

PRIORITY CLAIMED UNDER SEC. 44(D) ON CANADA APPLICATION NO. 1414394, FILED 10-14-2008.

#### **CLASS 7—MACHINERY**

FOR PARTS FOR POWER OPERATED SAWS, NAMELY, EXCHANGEABLE SAW BLADES, EXCHANGEABLE ROUTER BITS AND EXCHANGEABLE BLADES FOR HOLE SAWS AND RECIPROCATING SAWS (U.S. CLS. 13, 19, 21, 23, 31, 34 AND 35).

#### **CLASS 37—CONSTRUCTION AND REPAIR**

FOR REMANUFACTURING AND RECONDITIONING OF SAW BLADES, ROUTER BITS AND BLADES FOR HOLE SAWS AND RECIPROCATING SAWS (U.S. CLS. 100, 103 AND 106).

#### **CLASS 40—MATERIAL TREATMENT**

FOR RECYCLING OF USED METAL TOOL ACCESSORIES (U.S. CLS. 100, 103 AND 106).

MARGARET POWER, EXAMINING ATTORNEY

SN 77-706,772. PRO-MART INDUSTRIES, INC., IRVINE, CA. FILED 4-3-2009.

## **MAGICBAG**

THE MARK CONSISTS OF STANDARD CHARACTERS WITHOUT CLAIM TO ANY PARTICULAR FONT, STYLE, SIZE, OR COLOR.

#### **CLASS 18—LEATHER GOODS**

FOR REUSABLE SHOPPING BAGS; ACCESSORY BAGS, NAMELY, COSMETIC BAGS SOLD EMPTY; ALL-PURPOSE CARRYING BAGS IN THE NATURE OF BAGS HAVING A TENSION-LOOP FRAME WHICH EXPANDS THE BAGS WHEN UNRESTRAINED (U.S. CLS. 1, 2, 3, 22 AND 41).

#### **CLASS 22—CORDAGE AND FIBERS**

FOR VACUUM COMPRESSION BAGS AND HANGING BAGS, NAMELY, PLASTIC BAGS WITH ONE-WAY VALVES, IN WHICH AIR IS EVACUATED FOR STORING CLOTHING OR BEDDING; CLOTH BAGS FOR STORAGE, BUT NOT FOR LUGGAGE OR TRAVEL; GARMENT BAGS FOR STORAGE, SHOE BAGS FOR STORAGE; POLY PROPYLENE BAGS USED FOR THE STORAGE OF CLOTHING AND BEDDING FOR USE UNDER BED; MESH BAGS FOR STORAGE; LAUNDRY WASH BAGS, MULTI-PURPOSE CLOTH BAGS, NAMELY, FOR HOLDING CLOTHES PINS, CANVAS BAGS FOR STORAGE OF TOYS (U.S. CLS. 1, 2, 7, 19, 22, 42 AND 50).

JULIE GUTTADAURO, EXAMINING ATTORNEY

SN 77-724,647. SECURE ELECTRANS LTD, CAPENHURST, CHESTER, UNITED KINGDOM, FILED 4-29-2009.

SN 77-724,471. PELAGO, INC., SEATTLE, WA. FILED 4-28-2009.

# GREENGAGE

## WHAT'S YOUR STORY?

THE MARK CONSISTS OF STANDARD CHARACTERS WITHOUT CLAIM TO ANY PARTICULAR FONT, STYLE, SIZE, OR COLOR.

THE MARK CONSISTS OF STANDARD CHARACTERS WITHOUT CLAIM TO ANY PARTICULAR FONT, STYLE, SIZE, OR COLOR.

OWNER OF ERPN CMNTY TM OFC REG. NO. 007072028, DATED 5-16-2010, EXPIRES 7-17-2018.

### CLASS 9—ELECTRICAL AND SCIENTIFIC APPARATUS

FOR SOCIAL NETWORKING SOFTWARE FOR USE WITH MOBILE AND WIRED COMPUTERS, PERSONAL DIGITAL ASSISTANTS (PDAS), AND MOBILE TELEPHONES TO ENABLE USERS TO LOCATE AND INTERACT WITH OTHER USERS AND GROUPS SHARING SIMILAR INTERESTS OR LOCATIONS; COMPUTER SOFTWARE FOR USE WITH MOBILE AND WIRED COMPUTERS, PERSONAL DIGITAL ASSISTANTS (PDAS), AND MOBILE TELEPHONES TO RENDER DATA, IMAGES, AND MESSAGES REGARDING POINTS OF INTEREST, ENTERTAINMENT AND EDUCATION VENUES AND EVENTS, CIVIC EVENTS AND COMMERCIAL ESTABLISHMENTS AND INDIVIDUALS, ALL FOR SOCIAL NETWORKING AND OTHER PURPOSES (U.S. CLS. 21, 23, 26, 36 AND 38).

### CLASS 9—ELECTRICAL AND SCIENTIFIC APPARATUS

FOR COMPUTER HARDWARE, FIRMWARE AND SOFTWARE RELATING TO THE HANDLING OF FINANCIAL TRANSACTIONS; ELECTRONIC APPARATUS FOR PROCESSING FINANCIAL TRANSACTIONS; ELECTRONIC APPARATUS FOR READING AND DISPLAYING INFORMATION STORED ON UTILITY METERS; ELECTRONIC APPARATUS FOR READING AND DISPLAYING INFORMATION STORED ON BANK CARDS, CREDIT CARDS, DEBIT CARDS OR PAYMENT CARDS; ELECTRONIC APPARATUS FOR VERIFYING THE AUTHENTICITY OF BANK CARDS, CREDIT CARDS, DEBIT CARDS OR PAYMENT CARDS; BLANK SMART CARDS; CARTRIDGES, DISKS, AND TAPES FOR COLLECTING AND/OR STORING DATA; ENCODERS, DECODERS, ELECTRONIC CARD READERS; COMPUTER SOFTWARE ALLOWING THE USER TO OBTAIN ACCESS TO FINANCIAL SERVICES ELECTRONICALLY; ELECTRONIC AUTOMATIC SYSTEMS COMPRISED PRIMARILY OF PAYMENT TERMINALS AND COMMUNICATION HUBS FOR FINANCIAL TRANSACTIONS OR FINANCIAL INFORMATION; PRE-PAYMENT SYSTEMS COMPRISED PRIMARILY OF PAYMENT TERMINALS AND COMMUNICATION HUBS FOR COMMODITIES; ELECTRONIC APPARATUS FOR MEASURING ENERGY, WATER AND ENVIRONMENTAL PARAMETERS; PAYMENT AND PRE-PAYMENT SYSTEMS COMPRISED PRIMARILY OF PAYMENT TERMINALS AND COMMUNICATION HUBS FOR USE IN CONNECTION WITH THE GAS, ELECTRICITY, WATER AND TELEPHONE UTILITIES; DATA CARRIERS; DATA STORAGE MEDIA, NAMELY, BLANK ELECTRONIC STORAGE MEDIA; BLANK MAGNETIC DATA CARRIER READERS; ENCODED SMART CARDS CONTAINING PROGRAMMING USED TO AUTHORIZE THE PAYMENT OF GOODS AND SERVICES; ENCODED SMART CARDS CONTAINING IDENTIFICATION DATA; MAGNETICALLY ENCODED PAYMENT CARDS; SMART CARD READERS; GAS METERS; ELECTRICITY METERS; WATER METERS; TELECOMMUNICATIONS APPARATUS IN THE NATURE OF ROUTERS AND MODEMS; COMPUTER SOFTWARE, HARDWARE AND FIRMWARE FOR MONITORING THE PERFORMANCE OF HOUSEHOLD ELECTRICAL AND ELECTRONIC EQUIPMENT (U.S. CLS. 21, 23, 26, 36 AND 38).

### CLASS 38—COMMUNICATION

FOR WIRELESS TELECOMMUNICATIONS SERVICES, NAMELY, TRANSMISSION OF DATA, IMAGES, SIGNALS, AND MESSAGES, ALL FOR SOCIAL NETWORKING AND OTHER PURPOSES (U.S. CLS. 100, 101 AND 104).

### CLASS 42—SCIENTIFIC AND COMPUTER SERVICES

FOR PROVIDING COMPUTER SEARCH ENGINE SERVICES FOR USER-DEFINED SEARCHING OF TEXT, GRAPHICS, IMAGES, AND OTHER DATA, ALL FOR SOCIAL NETWORKING AND OTHER PURPOSES (U.S. CLS. 100 AND 101).

### CLASS 43—HOTEL AND RESTAURANT SERVICES

FOR PROVIDING INFORMATION ABOUT RESTAURANTS, BARS, AND OTHER ESTABLISHMENTS SERVING FOOD OR DRINK ALL FOR SOCIAL NETWORKING AND OTHER PURPOSES; PROVIDING A WEBSITE FEATURING INFORMATION ON RESTAURANTS, BARS, AND OTHER ESTABLISHMENTS SERVING FOOD OR DRINK, ALL FOR SOCIAL NETWORKING AND OTHER PURPOSES (U.S. CLS. 100 AND 101).

### CLASS 45—PERSONAL AND LEGAL SERVICES

FOR ONLINE SOCIAL NETWORKING SERVICES; PROVIDING A WEBSITE FEATURING INFORMATION ON INDIVIDUALS FOR SOCIAL NETWORKING PURPOSES AND PROVIDING INFORMATION ON INDIVIDUALS FOR SOCIAL NETWORKING PURPOSES (U.S. CLS. 100 AND 101).

ANDREW RHIM, EXAMINING ATTORNEY

### CLASS 36—INSURANCE AND FINANCIAL

FOR PROCESSING OF CREDIT CARD, DEBIT CARD AND CHARGE CARD TRANSACTIONS AND TRANSACTION DATA; FINANCIAL TRANSACTION PROCESSING SERVICES (U.S. CLS. 100, 101 AND 102).

### CLASS 38—COMMUNICATION

FOR DATA COMMUNICATIONS SERVICES VIA THE INTERNET (U.S. CLS. 100, 101 AND 104).

TINA L. SNAPP, EXAMINING ATTORNEY

SN 77-733,444. RECKITT BENCKISER INC., PARSIPPANY, NJ. FILED 5-11-2009.



PRIORITY CLAIMED UNDER SEC. 44(D) ON ERP CMNTY TM OFC APPLICATION NO. 008225278, FILED 4-17-2009.

THE COLOR(S) BLUE, WHITE AND GREY IS/ARE CLAIMED AS A FEATURE OF THE MARK.

THE MARK CONSISTS OF A STYLIZED WHITE AND BLUE BUBBLE DESIGN WITH WHITE HIGHLIGHTS, GREY SHADING, A BLUE-GREY SHADOW, AND A BLUE SILHOUETTE WITH A SECOND SMALLER IDENTICAL BUBBLE DESIGN APPEARING ABOVE TO THE UPPER RIGHT OF THE LARGER.

#### CLASS 5—PHARMACEUTICALS

FOR AIR FRESHENING PREPARATIONS; AIR PURIFYING PREPARATIONS; ROOM AIR FRESHENERS; AIR DEODORANT; PREPARATIONS FOR NEUTRALIZING ODOURS ON CARPETING, TEXTILES, SURFACES AND IN THE AIR (U.S. CLS. 6, 18, 44, 46, 51 AND 52).

#### CLASS 11—ENVIRONMENTAL CONTROL APPARATUS

FOR ELECTRIC AND BATTERY POWERED DISPENSERS FOR ROOM FRAGRANCES, AIR FRESHENERS AND ROOM DEODORANTS FOR SCENTING, PURIFYING OR FRESHENING THE ATMOSPHERE; PARTS AND FITTINGS FOR ALL THE AFORESAID GOODS SOLD AS A UNIT THEREWITH (U.S. CLS. 13, 21, 23, 31 AND 34).

LEIGH LOWRY, EXAMINING ATTORNEY

SN 77-751,363. QUATTRINI, FABRIZIO, BUENOS AIRES, ARGENTINA, FILED 6-3-2009.

ZIBILIA

THE MARK CONSISTS OF STANDARD CHARACTERS WITHOUT CLAIM TO ANY PARTICULAR FONT, STYLE, SIZE, OR COLOR.

PRIORITY CLAIMED UNDER SEC. 44(D) ON ARGENTINA APPLICATION NO. 2.880.643, FILED 12-5-2008, REG. NO. 2333083, DATED 12-3-2009, EXPIRES 12-3-2019.

PRIORITY CLAIMED UNDER SEC. 44(D) ON ARGENTINA APPLICATION NO. 2.880.642, FILED 12-5-2008, REG. NO. 2880642, DATED 12-3-2009, EXPIRES 12-3-2019.

PRIORITY CLAIMED UNDER SEC. 44(D) ON ARGENTINA APPLICATION NO. 2.880.641, FILED 12-5-2008, REG. NO. 2333113, DATED 12-3-2009, EXPIRES 12-3-2019.

OWNER OF ARGENTINA REG. NO. 239440, DATED 9-17-2010, EXPIRES 9-17-2020.

#### CLASS 16—PAPER GOODS AND PRINTED MATTER

FOR BOOKS IN THE FIELD OF SPORTS AND CULTURE; COMIC BOOKS; COMIC STRIPS; GENERAL FEATURE MAGAZINES; MAGAZINES IN THE FIELD OF SPORTS, CULTURE AND COMICS (U.S. CLS. 2, 5, 22, 23, 29, 37, 38 AND 50).

#### CLASS 38—COMMUNICATION

FOR BROADCAST OF CABLE TELEVISION PROGRAMMES; COMMUNICATION SERVICES, NAMELY, TRANSMISSION OF VOICE, AUDIO, VISUAL IMAGES AND DATA BY TELECOMMUNICATIONS NETWORKS, WIRELESS COMMUNICATION NETWORKS, THE INTERNET, INFORMATION SERVICES NETWORKS AND DATA NETWORKS (U.S. CLS. 100, 101 AND 104).

#### CLASS 41—EDUCATION AND ENTERTAINMENT

FOR EDUCATIONAL AND ENTERTAINMENT SERVICES, NAMELY, A CONTINUING PROGRAM ABOUT SPORTS, CULTURE, COMICS AND GENERAL INFORMATION ACCESSIBLE BY RADIO, TELEVISION, SATELLITE, AUDIO, VIDEO AND COMPUTER NETWORKS; MULTIMEDIA ENTERTAINMENT SERVICES IN THE NATURE OF DEVELOPMENT, PRODUCTION AND POST-PRODUCTION SERVICES IN THE FIELDS OF VIDEO AND FILMS; PRODUCTION AND DISTRIBUTION OF TELEVISION SHOWS AND MOVIES; PRODUCTION OF CABLE TELEVISION PROGRAMS; PRODUCTION OF CLOSED CAPTION TELEVISION PROGRAMS; PRODUCTION OF VIDEO DISCS AND TAPES; PROVIDING AN INTERNET WEBSITE PORTAL IN THE FIELD OF ENTERTAINMENT, CULTURAL AND SPORTING EVENTS; PROVISION OF NON-DOWNLOADABLE FILMS AND TELEVISION PROGRAMMES VIA A VIDEO-ON-DEMAND SERVICE (U.S. CLS. 100, 101 AND 107).

HOWARD SMIGA, EXAMINING ATTORNEY

SN 77-754,173. ASTHMATX, INC., SUNNYVALE, CA. FILED 6-8-2009.



THE MARK CONSISTS OF TWO CONCENTRIC OVALS, EACH OPEN AT ONE END.

#### CLASS 9—ELECTRICAL AND SCIENTIFIC APPARATUS

FOR PRERECORDED DVDS, CDS, VIDEO TAPES, AND LASER DISKS FEATURING INFORMATION ON THE TREATMENT OF PULMONARY DISEASES; PRE-RECORDED DVDS, CDS, VIDEO TAPES, AND LASER DISKS FEATURING INFORMATION ON THE TRAINING AND TEACHING OF SURGERY AND TREATMENT OF PULMONARY DISEASES (U.S. CLS. 21, 23, 26, 36 AND 38).

FIRST USE 9-30-2010; IN COMMERCE 9-30-2010.

**CLASS 10—MEDICAL APPARATUS**

FOR MEDICAL THERAPEUTIC DEVICES FOR USE IN THE TREATMENT OF PULMONARY DISEASES, NAMELY, CATHETERS, PROBES, GENERATORS, CONTROLLERS, BRONCHOSCOPES AND PARTS AND FITTINGS THEREFOR, ELECTRODES, FOOTSWITCHES; MEDICAL THERAPEUTIC DEVICES FOR USE IN THE TREATMENT OF PULMONARY DISEASES, NAMELY, MAPPING EQUIPMENT, NAMELY, HARDWARE CONSISTING OF LOCATING IMPLEMENT, SENSOR, RENDERING SYSTEM, NAMELY, NAVIGATION TOOL FOR THE PURPOSE OF COMPILING IMAGES AND DATA, MONITOR, AND COMPUTER, AND SOFTWARE ASSOCIATED THEREWITH; IMAGING EQUIPMENT, NAMELY, ULTRASONIC, COMPUTER AIDED TOMOGRAPHY, MAGNETIC RESONANCE, POSITRON EMISSION TOMOGRAPHY, OPTICAL COHERENCE TOMOGRAPHY, AND RADIOGRAPHIC MACHINES; MEDICAL ILLUMINATION EQUIPMENT, NAMELY, LIGHT SOURCES COMPRISING LED'S, LASERS, AND OPTICAL FIBERS, ALL FOR USE IN THE TREATMENT OF PULMONARY DISEASES AND SPECIFICATION SHEETS FOR THE FOREGOING (U.S. CLS. 26, 39 AND 44).

**CLASS 41—EDUCATION AND ENTERTAINMENT**

FOR TRAINING AND TEACHING IN THE FIELD OF SURGERY AND TREATMENT OF PULMONARY DISEASES, NAMELY, TRAINING AND TEACHING IN THE USE AND OPERATION OF MEDICAL DEVICES FOR BRONCHOSCOPY, BRONCHIAL THERMOPLASTY, SURGERY OR TREATMENT AND PRINTED MATERIALS DISTRIBUTED IN CONNECTION THEREWITH (U.S. CLS. 100, 101 AND 107).

FIRST USE 5-16-2009; IN COMMERCE 5-16-2009.  
SANJEEV VOHRA, EXAMINING ATTORNEY

SN 77-756,706. WASHGEAR, LLC, GRAND JUNCTION, CO.  
FILED 6-10-2009.

**CARD WORKS**

THE MARK CONSISTS OF STANDARD CHARACTERS WITHOUT CLAIM TO ANY PARTICULAR FONT, STYLE, SIZE, OR COLOR.

NO CLAIM IS MADE TO THE EXCLUSIVE RIGHT TO USE "CARD", APART FROM THE MARK AS SHOWN.

**CLASS 9—ELECTRICAL AND SCIENTIFIC APPARATUS**

FOR MAGNETICALLY AND ELECTRONICALLY CODED STORED-VALUE CARDS, POINT OF SALE TERMINALS, AND VENDING MACHINES, MAGNETICALLY AND ELECTRONICALLY CODED CARD READERS AND OPERATING AND ANALYZING SOFTWARE THEREFOR, ALL OF WHICH ARE USED IN THE VEHICLE AND TRAILER WASHING INDUSTRY NOT FOR USE WITH COMMERCIAL LAUNDRY EQUIPMENT (U.S. CLS. 21, 23, 26, 36 AND 38).

FIRST USE 11-25-2002; IN COMMERCE 11-25-2002.

**CLASS 42—SCIENTIFIC AND COMPUTER SERVICES**

FOR TECHNICAL SUPPORT SERVICES, NAMELY, PROVIDING SOFTWARE UPGRADES IN CONNECTION WITH MAGNETICALLY AND ELECTRONICALLY CODED STORED-VALUE CARDS, POINT OF SALE TERMINALS, VENDING MACHINES, AND MAGNETICALLY AND ELECTRONICALLY CODED CARD READERS, ALL OF WHICH ARE USED IN THE VEHICLE AND TRAILER WASHING INDUSTRY NOT FOR USE WITH COMMERCIAL LAUNDRY EQUIPMENT (U.S. CLS. 100 AND 101).

FIRST USE 11-25-2002; IN COMMERCE 11-25-2002.  
RUSS HERMAN, EXAMINING ATTORNEY

SN 77-756,809. WASH GEAR, LLC, GRAND JUNCTION, CO.  
FILED 6-10-2009.



NO CLAIM IS MADE TO THE EXCLUSIVE RIGHT TO USE "WASH", APART FROM THE MARK AS SHOWN.

THE MARK CONSISTS OF THE WORD "WASH" ABOVE TWO MECHANICAL GEARS WITH THEIR TEETH MESHED TOGETHER WITH TWO DROPS OF WATER COMING OUT OF THE MESHED AREA AND WITH THE WORD "GEAR" BELOW THE GEARS.

**CLASS 9—ELECTRICAL AND SCIENTIFIC APPARATUS**

FOR MAGNETICALLY AND ELECTRONICALLY CODED STORED-VALUE CARDS, POINT OF SALE TERMINALS, AND VENDING MACHINES, MAGNETICALLY AND ELECTRONICALLY CODED CARD READERS AND OPERATING AND ANALYZING SOFTWARE THEREFOR, ALL OF WHICH ARE USED IN THE VEHICLE AND TRAILER WASHING INDUSTRY NOT FOR USE WITH COMMERCIAL LAUNDRY EQUIPMENT (U.S. CLS. 21, 23, 26, 36 AND 38).

FIRST USE 11-25-2002; IN COMMERCE 11-26-2002.

**CLASS 42—SCIENTIFIC AND COMPUTER SERVICES**

FOR TECHNICAL SUPPORT SERVICES, NAMELY, PROVIDING SOFTWARE UPGRADES AND DIAGNOSTIC TROUBLESHOOTING IN CONNECTION WITH MAGNETICALLY AND ELECTRONICALLY CODED STORED-VALUE CARDS, POINT OF SALE TERMINALS, VENDING MACHINES, AND MAGNETICALLY AND ELECTRONICALLY CODED CARD READERS, ALL OF WHICH ARE USED IN THE VEHICLE AND TRAILER WASHING INDUSTRY NOT FOR USE WITH COMMERCIAL LAUNDRY EQUIPMENT (U.S. CLS. 100 AND 101).

FIRST USE 11-25-2005; IN COMMERCE 11-25-2005.  
RUSS HERMAN, EXAMINING ATTORNEY

SN 77-762,478. STEREN BRANDS, S. DE R.L. DE C.V., MEXICO CITY, MEXICO, FILED 6-17-2009.

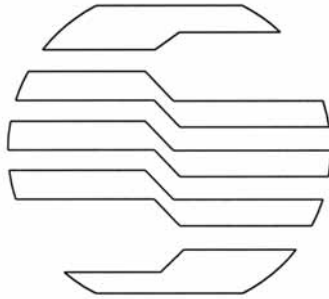

THE MARK CONSISTS OF A CIRCULAR DESIGN WITH WAVED LINES WHICH APPEAR AS CIRCUITRY IN THE SHAPE OF THE LETTER "S".

#### CLASS 7—MACHINERY

FOR ELECTRIC JUICERS; ELECTRIC DRILLS (U.S. CLS. 13, 19, 21, 23, 31, 34 AND 35).

#### CLASS 9—ELECTRICAL AND SCIENTIFIC APPARATUS

FOR PARTICLE ACCELERATORS; ACIDIMETERS FOR BATTERIES; ACIDIMETERS FOR ACCUMULATORS AND BATTERIES; ACOUSTIC COUPLERS; ELECTRIC COUPLERS; ACTINOMETERS; ACCUMULATOR BOXES; RECHARGERS FOR ACCUMULATOR BOXES; RECEIVING OR CONTAINERS ACCUMULATORS; ACCUMULATORS ANODE; ELECTRIC ACCUMULATOR; CHARGERS FOR ELECTRIC ACCUMULATORS; GRID FOR ELECTRIC ACCUMULATORS; ELECTRIC ACCUMULATORS FOR VEHICLE; ACOUSTICS SOUND ALARMS; COUPLES FOR ACOUSTICS; ACOUSTICS ELECTRICAL DUCTS; BLANK ACOUSTICS RECORDING DISCS; AEROMETER; NOTEBOOK COMPUTERS; APPARATUS AND INSTRUMENT SURVEYORS, NAMELY, SURVEYORS' LEVELS; INDICATORS FOR WATER LEVEL; ELECTRODYNAMICS DEVICES FOR THE REMOTE CONTROL NEEDLE RAILWAY CONTROLS; NEED TURNTABLE CARTRIDGES; NEEDLES FOR TURNTABLES; APPARATUS FOR IONIZATION, NAMELY, AUTOMATIC ION-EXCHANGE CHROMATOGRAPHY APPARATUS FOR LABORATORY USE, NOT FOR AIR TREATMENT; AIR ANALYSIS APPARATUS; STILLS FOR LABORATORY EXPERIMENTS; COPPER INSULATED ELECTRICAL WIRE; ELECTRIC WIRE; MAGNETIC WIRE; METAL ALLOY ELECTRICAL WIRES TO FUSE; TELEGRAPH WIRE; ELECTRONIC WARNING BELLS; SIGNAL WHISTLE; ALCOHOL METERS, NOT BREATH ANALYZERS; BATTERIES OF HIGH TENSION; LOUDSPEAKERS; SPEAKERS BOXES; ALTIMETER; BATTERIES FOR LIGHTING; AMPLIFIER; SCIENTIFIC INSTRUMENTS, NAMELY, ELECTRONIC ANALYZER FOR MEASURING GAS APPLIANCES; ANEMOMETER; INDUSTRIAL RINGS CALIBRATOR DEVICE FOR INSTRUMENTS; ANODES; BATTERIES FOR ANODES; ANTENNA; AERIAL ANTENNAS; ANTI-CATHODE; ANTI-INTERFERENCE DEVICES, NAMELY, ELECTRICITY CONDUITS; ELECTRIC ARC WELDERS; FIRE SPRINKLER; APPARATUS AND INSTRUMENTS FOR ASTRONOMY, NAMELY, TELESCOPES, BINOCULARS, EYE PIECES AND FILTERS; ELECTRICAL DEVICES TO ATTRACT AND KILL INSECTS; HEADSETS FOR MOBILE TELEPHONES, FOR USE WITH COMPUTERS; HEADSETS FOR ELECTRONIC LISTENING DEVICES; AUDIO AND VIDEO RECEIVER; AUDIO-VISUAL TEACHING EQUIPMENT, NAMELY, DATA PROJECTORS, SLIDE PROJECTORS, DVD PLAYERS AND OVERHEAD PROJECTORS; TELEPHONE HEADSETS; LIGHTING BALASTS; BRIGHT SIGNALING BUOY; BAROMETER; ELECTRIC BATTERIES; CHARGER FOR ELECTRIC BATTERIES; ELECTRIC BATTERIES FOR VEHICLE;

BATTERIES FOR FLASHLIGHTS; SOLAR BATTERIES; BINOCULARS; ELECTRICAL BOBBIN WIRES; AUDIO SPEAKERS; ELECTROMAGNETIC SWITCHES FOR MONITORING BOILER; ELECTRIC DOOR OPENERS; ELECTRICAL TELEPHONE CABLE; CABLE CONNECTORS; COAXIAL CABLE; FIBER OPTIC CABLES; ELECTRICAL CABLES; JUNCTION SLEEVES FOR ELECTRICAL CABLES; JUNCTION SLEEVES UNION FOR CABLES; ELECTRIC JUNCTION BOXES; ELECTRICAL DISTRIBUTION BOXES; CASH REGISTERS; CALCULATORS; CAMERAS; PORTABLE CAMCORDERS; LUMINOUS OR MECHANICAL ROAD SIGNS; BATTERY CHARGERS; VIDEO GAME CARTRIDGES; CASSETTE PLAYERS; VIDEO CASSETTES RECORDERS; OPTICAL READERS FOR COMPACT DISCS; BLANK AUDIO-VIDEO COMPACT DISCS; ELECTRONIC MEMORY CARD READERS FOR COMPACT DISC; CELL PHONES; ELECTRIC LOCKS; APPLIANCES TO EDIT FILMS, NAMELY, SPLIT REELS, FILM SYNCHRONIZERS, PLASTIC CONES; FILM CAMERAS; EXPOSED CINEMATOGRAFIC FILMS; MAGNETIC TAPE DRIVES FOR COMPUTER; BLANK SOUND RECORDING TAPES; BLANK VIDEO TAPES; HEAD CLEANING TAPES FOR AUDIO AND VIDEO RECORDER; BLANK MAGNETIC COMPUTER TAPES; BLANK INTEGRATED CIRCUIT CARDS; ELECTRONIC SHORT CIRCUITS; PRINTED CIRCUITS; INTEGRATED CIRCUITS; MAGNETIC ENCODERS; BARCODE SCANNERS; ELECTRONIC MEMORY CARD READS FOR COMPACT DISCS; COMPUTER GAME PROGRAMS; PRINTERS FOR COMPUTERS; MEMORY CARDS FOR COMPUTER; KEYBOARD FOR COMPUTERS; LAPTOPS COMPUTERS; ELECTRIC CAPACITORS; ELECTRIC CONDUCTORS; ELECTRICAL CONNECTORS; ELECTRICAL CONNECTIONS FOR POWER LINES; ELECTRIC SWITCHES; ELECTRIC DISTRIBUTION CONSOLE; ANSWERING MACHINES AND REMOTE CONTROL FOR RADIOS, TELEVISIONS, STEREOS; ELECTRICAL CONVERTERS; CURRENT RECTIFIERS; ELECTRIC CURRENT SWITCHES; DATE PROCESSORS; ODOMETER; BLANK MAGNETIC DATA CARRIERS; BLANK OPTICAL DATA CARRIERS; DENSIMETER; SMOKE DETECTOR; ELECTRIC LIGHT DIMMERS; DYNAMOMETER; CURRENCY COUNTING MACHINES; BLANK MAGNETIC DISKS; BLANK ACOUSTIC RECORDING DISCS; COMPACT DISCS PLAYERS; DISK DRIVE FOR COMPUTER; BLANK FLOPPY COMPUTERS DISCS; GLOBAL POSITIONING SYSTEMS (GPS); ELECTRICAL ENTERTAINMENT DEVICES TO BE USED EXCLUSIVELY WITH A TELEVISION RECEIVER, NAMELY, REMOTE CONTROL DEVICES, JOY STICKS, VIDEO PLAYERS, VIDEO GAME MACHINES FOR USE WITH AN EXTERNAL DISPLAY SCREEN OR MONITOR; SCANNERS FOR PROCESSING INFORMATION; SPECTROGRAPH APPARATUS; LABORATORY EQUIPMENT, NAMELY, SPECTROSCOPE; PERSONAL STEREOS; OPTICAL FIBERS; PHOTOGRAPHIC FLASHBULBS; FLUORESCENT SCREENS; PHOTOCOPIERS; ELECTROSTATIC COPYING MACHINES; THERMAL PRINTERS; PHOTO TELEGRAPHY APPARATUS; APPARATUS FOR RECORDING OR REPRODUCTION OF SOUND; PHOTO PRINTERS; ELECTRICAL SWITCHES; FLASH LAMPS; LASER NOT FOR MEDICAL USE; OPTICAL READERS; AUDIO PROCESSING EQUIPMENT, NAMELY, LIMITERS AND COMPRESSORS; AUTOMATIC ELECTRICAL DISTRIBUTION APPARATUS; DEVICES FOR MEASURING PRESSURE, NAMELY, PRESSURE GAUGES, PRESSURE METERS; COMPUTER MONITORS; COMPUTER MOUSE; SATELLITE NAVIGATIONAL SYSTEMS, A GLOBAL POSITIONING SYSTEM (GPS); NEON SIGNS; EYE OSCILLOGRAPH, ELECTRIC CONTROL PANELS; PROJECTION SCREEN; VIDEO SCREEN; LIGHTNING ROD; ELECTRIC IRONS FOR IRONING CLOTHES; HEAT SEALING MACHINES FOR PACKING; ELECTRONIC PENS FOR UNITS VISUAL REPRESENTATION; POLARIZING MICROSCOPES; ELECTRIC DOOR BELLS; TWO-WAY RADIOS, NAMELY, WALKIE-TALKIES; RADIO TRANSMITTER; PAGERS; RADIOS; RADIOS FOR VEHICLES; TELEPHONE RECEIVERS; MATERIAL FOR ELECTRICITY GRIDS, NAMELY, ELECTRIC WIRES AND CABLES; ELECTRIC CONDUCTOR RAILS; ELECTRICAL RELAY; ELECTRICAL INSTALLATIONS FOR PREVENTION OF ROBBERY, NAMELY, ELECTRIC AND ELECTRONIC VIDEO SURVEILLANCE INSTALLATIONS; RADIOTELEPHONY SETS; SIRENS; TACHOMETER; COMPUTER KEYBOARDS; VIDEOPHONE; MOBILE PHONES; TELEGRAPHS; TELEPRINTER; TELETYPEWRITERS; TELEVISION SETS; TEMPERATURE INDICATORS;

THERMOSTATS; TRANSFORMER; TRANSISTORS; ILLUMINATION REGULATORS; SPEEDOMETER; SPEED INDICATORS; VIDEO RECORDER; VOLTAGE SURGE PROTECTORS; VOLTMETER; ELECTRIC BUZZERS; WIRELESS NETWORK ROUTER; UNIVERSAL SERIAL BUS HARDWARE (UBS); HAND HELD JOY STICK UNITS FOR PLAYING VIDEO GAMES; MEMORIES FOR USE WITH COMPUTERS; POWER SUPPLIES; ELECTRONIC CABLES; WIRELESS TRANSMITTERS AND RECEIVERS FOR PORTABLE MEDIA PLAYER; SATELLITE RECEIVER FOR FREE AND PAID CHANNELS; SIGNAL SPLITTERS FOR ELECTRONIC APPARATUS; CONVERTERS; SPARK LIGHTNING ARRESTERS; ELECTRICAL RESISTORS; POCKET TRANSLATOR; VACUUM PRESSURE GAUGE; SPEEDOMETER; SIGNAL SPLITTER FOR ELECTRONIC APPARATUS; AUDIO AND VIDEO CONVERTERS; TELEPHONE EQUIPMENT, NAMELY, CALLER IDENTIFICATION BOXES; TAPE RECORDERS AND ACCESSORIES AND PARTS THEREOF, NAMELY, CARRYING CASES, RECHARGEABLE BATTERY PACKS, CAR BATTERY CABLES; DIGITAL VERSATILE DISC PLAYER; WIRED AND WIRELESS MICROPHONES; ANNOUNCING MACHINES, NAMELY, LOUD SPEAKERS; LOUD-SPEAKERS FOR STEREOPHONIC AND MONOPHONIC SOUND REPRODUCTION; AUTOMATIC-TRANSFORMERS; AMPLIFIERS; INVERTERS; ELECTRIC VACUUM-TUBES REPLACEMENT DEVICES, NAMELY, SOLID-STATE VACUUM TUBE EMULATORS; CONVERTERS; PICKUPS; ELECTRIC-COMMUNICATING APPARATUS, NAMELY, FACSIMILE TELEPHONES MACHINES AND TELEPHONES WITH TWO WAY VIDEO TRANSMITTERS; DICTATING MACHINES; TELEVISION CAMERAS; ELECTRICAL SOUND RECORDING APPARATUS COMPRISING ELECTRIC RECORD PLAYERS; VIDEO TAPE RECORDERS; VIDEO DISC PLAYERS; VIDEO CAMERAS; RECORDED VIDEO TAPES FEATURING MOTION PICTURES AND MUSICAL PERFORMANCES; BLANK VIDEO TAPES; COMPUTERS; WORD PROCESSORS; TELEPHONES; TRANSCEIVERS; HEADPHONES; PERSONAL STEREO; CAR STEREO; STEREO TUNERS; AUDIO SPEAKERS; BLANK AUDIO CASSETTE TAPES AND PRERECORDED CASSETTE TAPES FEATURING MUSICAL PERFORMANCES; EARPHONES; GRAPHIC EQUALIZERS; ELECTRIC IRONS; NINE VOLT BATTERIES; RADIOS COMBINED WITH ALARM CLOCKS; SEMICONDUCTORS; REMOTE CONTROL UNITS FOR TELEVISION RECEIVERS; MAGNETIC MEASURING APPARATUS, NAMELY, DIGITAL GEIGER COUNTER; MAGNETIC VIDEO RECORDERS AND PLAYERS AND BLANK MAGNETIC TAPE FOR RECORDING VIDEO AND AUDIO; TELEVISION MONITORS WITH AND WITHOUT TELEVISION TUNERS; NON-ELECTRIC SOUND AMPLIFIERS IN THE SHAPE OF HEADPHONES; PROJECTION TELEVISIONS; VIDEO CAMERAS COMBINED WITH VIDEO TAPE RECORDERS; COMPUTER JOYSTICKS; COMPUTER CONNECTION CABLES AND CONNECTORS; COLOR VIDEO PROJECTORS; MICRO TELEVISIONS; COMPACT DISC CHANGERS USED TO CHANGE PLAYBACK AND SELECTION OF MULTIPLE COMPACT DISCS; VIDEO CAMERA LENSES; OPTICAL SCALES AND ENCODERS FOR LINEAR AND ANGULAR POSITION SENSING; UTILIZING LASERS FOR NON-MEDICAL PURPOSES; UNITS FOR MEASURING DISPLACEMENT, LINEAR OR ANGULAR, WHICH UTILIZE DIFFRACTION GRATING AND LASER UNITS; FLOPPY DISC VIDEO PLAYERS; FLOPPY DISC VIDEO CAMERAS; BLANK FLOPPY DISCS FOR USE IN VIDEO PLAYERS AND CAMERAS; VIDEO CAMERA CONTROL UNITS COMPRISED OF VIDEO CAMERA SIGNAL PROCESSOR, VIDEO CAMERA CONTROL POWER UNIT, VIDEO CAMERA OPERATIONAL CONTROL UNIT AND WAVE FORM MONITOR; VIDEO CAMERA ACCESSORIES, NAMELY, OPTICAL FIBER CABLES, VIDEO CAMERA IMAGE ENHANCERS AND VIDEO CAMERA CABLE; ELECTRONIC STILL CAMERAS AND PARTS AND ACCESSORIES THEREFORE, NAMELY, BLANK MAGNETIC DISKS (U.S. CLS. 21, 23, 26, 36 AND 38).

#### **CLASS 11—ENVIRONMENTAL CONTROL APPARATUS**

FOR LAMPS, RESPIRATORS TO FILTER THE AIR OTHER THAN FOR ARTIFICIAL RESPIRATION (U.S. CLS. 13, 21, 23, 31 AND 34).  
ALICE BENMAMAN, EXAMINING ATTORNEY

SN 77-773,260. ASI SIGN SYSTEMS, INC., DALLAS, TX.  
FILED 7-2-2009.



OWNER OF U.S. REG. NOS. 1,203,363 AND 2,368,900.  
THE MARK CONSISTS OF THREE DIAMOND SHAPES FOLLOWED BY THE LETTERS "ASI."

#### **CLASS 6—METAL GOODS**

FOR NON-LUMINOUS AND NON-MECHANICAL METAL SIGNS; METAL LETTERS AND NUMBERS FOR USE IN MAKING SIGNS; ALUMINUM SIGNS (U.S. CLS. 2, 12, 13, 14, 23, 25 AND 50).

#### **CLASS 9—ELECTRICAL AND SCIENTIFIC APPARATUS**

FOR DIGITAL SIGNAGE MONITORS; ELECTRONIC LED AND LCD SIGNS; LUMINOUS SIGNS; NEON SIGNS (U.S. CLS. 21, 23, 26, 36 AND 38).

#### **CLASS 16—PAPER GOODS AND PRINTED MATTER**

FOR VINYL LETTERS AND NUMBERS FOR USE IN MAKING SIGNS (U.S. CLS. 2, 5, 22, 23, 29, 37, 38 AND 50).

#### **CLASS 19—NON-METALLIC BUILDING MATERIALS**

FOR NON-LUMINOUS, NON-MECHANICAL SIGNS NOT OF METAL; NON-LUMINOUS ACRYLIC AND PLASTIC SIGNS (U.S. CLS. 1, 12, 33 AND 50).

#### **CLASS 20—FURNITURE AND ARTICLES NOT OTHERWISE CLASSIFIED**

FOR PLASTIC LETTERS FOR USE IN MAKING COMMERCIAL SIGNS; PLASTIC SIGNBOARDS; ACRYLIC LETTERS FOR USE IN MAKING COMMERCIAL SIGNS (U.S. CLS. 2, 13, 22, 25, 32 AND 50).

#### **CLASS 21—HOUSEWARES AND GLASS**

FOR FIBERGLASS SIGNS (U.S. CLS. 2, 13, 23, 29, 30, 33, 40 AND 50).

#### **CLASS 35—ADVERTISING AND BUSINESS**

FOR BRANDING SERVICES, NAMELY, CONSULTING, DEVELOPMENT, MANAGEMENT AND MARKETING OF BRANDS FOR BUSINESSES (U.S. CLS. 100, 101 AND 102).

#### **CLASS 37—CONSTRUCTION AND REPAIR**

FOR INSTALLATION AND MAINTENANCE OF SIGNS AND LETTERING SYSTEMS (U.S. CLS. 100, 103 AND 106).

#### **CLASS 40—MATERIAL TREATMENT**

FOR CUSTOM MANUFACTURE AND FABRICATION OF SIGNS AND LETTERING SYSTEMS; CUSTOM MANUFACTURE OF SIGNAGE AND WAY FINDING SYSTEMS (U.S. CLS. 100, 103 AND 106).

**CLASS 42—SCIENTIFIC AND COMPUTER SERVICES**

FOR DESIGN SERVICES IN THE FIELD OF SIGNS, LETTERING SYSTEMS, AND WAYFINDING SYSTEMS FOR OTHERS AND CONSULTATION THEREOF; SITE SURVEY SERVICES FOR OTHERS IN THE FIELD OF SIGNAGE (U.S. CLS. 100 AND 101).

NAKIA HENRY, EXAMINING ATTORNEY

SN 77-775,600. BIG STAR SANDY SHOES INC., PORT PERRY, ONTARIO, CANADA, FILED 7-7-2009.

# SALLAZZO

THE MARK CONSISTS OF STANDARD CHARACTERS WITHOUT CLAIM TO ANY PARTICULAR FONT, STYLE, SIZE, OR COLOR.

PRIORITY CLAIMED UNDER SEC. 44(D) ON CANADA APPLICATION NO. 1423723, FILED 1-7-2009, REG. NO. TMA783620, DATED 11-29-2010, EXPIRES 11-29-2025.

**CLASS 18—LEATHER GOODS**

FOR KNAPSACKS, HANDBAGS, SHOULDER BAGS (U.S. CLS. 1, 2, 3, 22 AND 41).

**CLASS 25—CLOTHING**

FOR SPORTS AND CASUAL CLOTHING, NAMELY, SWEAT PANTS, T-SHIRTS, JACKETS, SOCKS, HEAD BANDS, HATS, VESTS, SMOCKS AND SWEATERS (U.S. CLS. 22 AND 39).

TARAH HARDY, EXAMINING ATTORNEY

SN 77-787,059. HOSTED SOLUTIONS ACQUISITION LLC, RALEIGH, NC. FILED 7-22-2009.

# HOSTED SOLUTIONS

THE MARK CONSISTS OF STANDARD CHARACTERS WITHOUT CLAIM TO ANY PARTICULAR FONT, STYLE, SIZE, OR COLOR.

NO CLAIM IS MADE TO THE EXCLUSIVE RIGHT TO USE "HOSTED", APART FROM THE MARK AS SHOWN. SEC. 2(F).

**CLASS 38—COMMUNICATION**

FOR PROVIDING THIRD PARTY ACCESS TO TELECOMMUNICATION INFRASTRUCTURE, NAMELY, MANAGED DATA CENTERS AND MEGA-SCALE COMPUTING ENVIRONMENTS, COMPUTER SERVERS, COMMUNICATION NETWORKS, OPERATING SYSTEM SOFTWARE, AND APPLICATION SOFTWARE; PROVIDING THIRD PARTY ACCESS TO TELECOMMUNICATION INFRASTRUCTURE, NAMELY, VIRTUAL AND NON VIRTUAL APPLICATION SERVERS, WEB SERVERS, FILE SERVERS, CO-LOCATION SERVERS, NETWORK AND LOAD BALANCING DEVICES, REDUNDANCY SERVERS, MEDIA SERVERS AND DATABASE SERVERS (U.S. CLS. 100, 101 AND 104).

FIRST USE 4-1-2004; IN COMMERCE 5-3-2004.

**CLASS 42—SCIENTIFIC AND COMPUTER SERVICES**

FOR COMPUTER SERVICES, NAMELY, APPLICATION SERVICE PROVIDER SERVICES FEATURING SOFTWARE FOR PROVIDING REMOTE HOSTING OF OPERATING SYSTEMS AND COMPUTER APPLICATIONS; PROVIDING TEMPORARY USE OF NON-DOWNLOADABLE SOFTWARE, ACCESSIBLE OVER A GLOBAL COMPUTER NETWORK, FOR MANAGING COMPUTER APPLICATIONS, AND PROVIDING CLOUD, GRID AND UTILITY COMPUTING SERVICES; RECORDING DATA FOR OTHERS ON OPTICAL, DIGITAL AND MAGNETIC MEDIA FOR ELECTRONIC STORAGE; COMPUTER SERVICES, NAMELY, REMOTE AND ON-SITE MANAGEMENT OF CLOUD COMPUTING SYSTEMS AND APPLICATIONS FOR OTHERS (U.S. CLS. 100 AND 101).

FIRST USE 4-1-2004; IN COMMERCE 5-3-2004.  
SANJEEV VOHRA, EXAMINING ATTORNEY

SN 77-795,210. HAZ/MAT DQE, INC., INDIANAPOLIS, IN. FILED 8-3-2009.

# DQE

THE MARK CONSISTS OF STANDARD CHARACTERS WITHOUT CLAIM TO ANY PARTICULAR FONT, STYLE, SIZE, OR COLOR.

**CLASS 9—ELECTRICAL AND SCIENTIFIC APPARATUS**

FOR EXTENSION CORDS, HAZARDOUS MATERIAL PROTECTIVE SUITS, PROTECTIVE WORK GLOVES, SHOE COVERS, SAFETY GOGGLES, PROTECTING MASKS; DECONTAMINATION SHOWERS, SHELTERS AND STRUCTURAL PARTS THEREFOR (U.S. CLS. 21, 23, 26, 36 AND 38).

FIRST USE 0-0-2005; IN COMMERCE 0-0-2005.

**CLASS 21—HOUSEWARES AND GLASS**

FOR KITS FOR CLEANING HAZARDOUS MATERIALS COMPRISED PRIMARILY OF CLEANING PADS AND PILLOWS FOR THE CONTAINMENT AND CLEAN-UP OF CHEMICAL AND OTHER SPILLS, BUCKETS, AND ALSO INCLUDING ADHESIVE LABELS, PROTECTIVE WORK GLOVES, SAFETY GOGGLES, PUTTY STICKS FOR PLUGGING LEAKS (U.S. CLS. 2, 13, 23, 29, 30, 33, 40 AND 50).

FIRST USE 0-0-2005; IN COMMERCE 0-0-2005.

**CLASS 25—CLOTHING**

FOR SHOE LINERS; KITS FOR DISASTER VICTIMS COMPRISED PRIMARILY OF WEARABLE GARMENTS AND CLOTHING, NAMELY SHIRTS, JACKETS, PANTS, UNDERGARMENTS, AND SOCKS, AND ALSO INCLUDING BAGS FOR THE COLLECTION OF CONTAMINATED CLOTHING, BAGS FOR SECURING PERSONAL VALUABLES, PAPER TOWELS, PRE-MOISTENED TOWELETTES FOR CLEANING, PENS, AND SCRUBBING BRUSHES (U.S. CLS. 22 AND 39).

FIRST USE 0-0-2005; IN COMMERCE 0-0-2005.



**CLASS 41—EDUCATION AND ENTERTAINMENT**

FOR EDUCATIONAL SERVICES, NAMELY, CONDUCTING PROGRAMS, WORKSHOPS, SEMINARS, AND SIMULATION DRILLS, IN THE FIELDS OF HEALTHCARE, SAFETY, DISASTER PREPAREDNESS AND MANAGEMENT, HAZARDOUS MATERIAL AND CONTAMINATION MANAGEMENT, AND MEDICAL AND EMERGENCY CARE; TRAINING AND ASSESSMENT IN THE FIELDS OF HEALTHCARE, SAFETY, DISASTER PREPAREDNESS AND MANAGEMENT, HAZARDOUS MATERIAL AND CONTAMINATION MANAGEMENT, AND MEDICAL AND EMERGENCY CARE (U.S. CLS. 100, 101 AND 107).

FIRST USE 0-0-2005, THE MARK WAS FIRST USED ANYWHERE IN A DIFFERENT FORM OTHER THAN THAT SOUGHT TO BE REGISTERED AT LEAST AS EARLY AS 00/00/2003; IN COMMERCE 0-0-2005, THE MARK WAS FIRST USED IN COMMERCE IN A DIFFERENT FORM OTHER THAN THAT SOUGHT TO BE REGISTERED AT LEAST AS EARLY AS 00/00/2003.

CHRIS WELLS, EXAMINING ATTORNEY

**CLASS 42—SCIENTIFIC AND COMPUTER SERVICES**

FOR SCIENTIFIC AND TECHNOLOGICAL SERVICES AND RESEARCH AND DESIGN SERVICES, ALL IN THE FIELD OF METAL CASTING; LABORATORY AND NON-DESTRUCTIVE METAL TESTING SERVICES FEATURING ON-SITE RADIOGRAPHY AND ULTRASONIC SCANNING SERVICES FOR TESTING DIE-PENETRATION IN CONNECTION WITH METAL CASTINGS; MATERIAL TESTING SERVICES FOR THE ANALYSIS OF METALS FEATURING CHEMICAL COMPOSITION, TENSILE STRENGTH, IMPACT RESISTANCE, HARDNESS, MAGNETIC PERMEABILITY AND CONDUCTIVITY; ENGINEERING AND METALLURGY SERVICES FEATURING ON-SITE CONCURRENT ENGINEERING UTILIZING COMPUTER SOFTWARE FOR DETERMINING DESIGN MANUFACTURABILITY, ALLOY SELECTION AND OPTIMIZED MANUFACTURING PROCESS SELECTION FOR ANALYSIS AND MODELING OF SOLIDIFICATION AND FLOW CHARACTERISTICS OF METAL CAST INTO MACHINE PARTS AND COMPONENTS (U.S. CLS. 100 AND 101).

RUSS HERMAN, EXAMINING ATTORNEY

SN 77-797,142. APOGEE ELECTRONICS CORPORATION, SANTA MONICA, CA. FILED 8-5-2009.

SN 77-796,128. MEIGHS CASTINGS LIMITED, STOKE-ON-TRENT, GREAT BRITAIN, FILED 8-4-2009.

# APOGEE

THE MARK CONSISTS OF STANDARD CHARACTERS WITHOUT CLAIM TO ANY PARTICULAR FONT, STYLE, SIZE, OR COLOR.

**CLASS 9—ELECTRICAL AND SCIENTIFIC APPARATUS**

FOR ANALOG TO DIGITAL CONVERTERS, DIGITAL TO ANALOG CONVERTERS, ELECTRONIC AUDIO MODIFIERS, SIGNAL PROCESSORS, INTERFACES, TONE MODULES, CONTROLLERS, EFFECTS PROCESSORS, AND EFFECTS PEDALS FOR USE WITH MUSICAL INSTRUMENTS, AMPLIFIERS, AND SOUND SPEAKERS; COMPUTER HARDWARE FOR RECORDING, MODELING, REPRODUCING, AND TRANSMITTING SOUND; DIGITAL INTERFACES FOR RECORDING, MODELING, REPRODUCING, AND TRANSMITTING SOUND; AMPLIFIERS FOR MUSICAL INSTRUMENTS AND PARTS AND ACCESSORIES FOR USE IN CONNECTION THEREWITH; COMPUTER SOFTWARE, NAMELY, AUDIO MODIFICATION SOFTWARE, AUDIO RECORDING SOFTWARE, AUDIO MODELING SOFTWARE, AND AUDIO EDITING SOFTWARE; COMPUTER SOFTWARE TO GENERATE AND CONTROL MUSICAL TONES FROM MICROPHONES AND MUSICAL INSTRUMENTS; COMPUTER SOFTWARE FOR ACCESSING PRERECORDED MUSIC; COMPUTER SOFTWARE FOR USE IN DOWNLOADING, UPLOADING, ACCESSING, RECORDING, EDITING, STORING, AND PLAYING MUSIC, TONES AND SOUNDS AND FOR PROVIDING ACCESS TO WEBSITES CONTAINING LIBRARIES OF MUSIC, TONES AND SOUNDS; DOWNLOADABLE AUDIO RECORDINGS, AUDIO SIGNAL MANIPULATION FOR REAL OR VIRTUAL MUSICAL INSTRUMENTS, ELECTRONIC EFFECTS PEDALS, ELECTRONIC FOOT CONTROLLED PEDALS FOR REMOTELY ACTIVATING AND SWITCHING FUNCTIONS ON COMPUTERS AND COMPUTER PROGRAMS, EXPRESSION PEDALS AND STOMP BOXES FOR USE WITH SOUND AMPLIFIERS AND MUSICAL INSTRUMENTS, ELECTRICAL APPARATUS FOR USE WITH GUITARS AND OTHER PURPOSES, NAMELY, LOUDSPEAKERS AND COMPONENTS AND ACCESSORIES FOR SUCH, NAMELY, CORDS, CONNECTORS, CABLES, SWITCHES, VOLUME AND RE-



OWNER OF ERPN CMNTY TM OFC REG. NO. 7224694, DATED 6-21-2009, EXPIRES 9-10-2018.

THE MARK CONSISTS OF THE LETTER "M" WITH TWO WAVES GOING THROUGH IT.

**CLASS 7—MACHINERY**

FOR MACHINE PARTS AND MACHINE COMPONENTS, NAMELY, CAST AND/OR MACHINED METAL MACHINE PARTS AND MACHINE COMPONENTS, NAMELY, BEARINGS, BUSHINGS, CYLINDERS, WEAR PLATES, AND HOODS, MADE FROM VARIOUS METAL ALLOYS INCLUDING NEARLY ANY BRONZE ALLOY, STAINLESS STEELS, NICKEL ALLOYS AND SPECIALTY AND PROPRIETARY METAL ALLOYS (U.S. CLS. 13, 19, 21, 23, 31, 34 AND 35).

**CLASS 40—MATERIAL TREATMENT**

FOR TREATMENT OF MATERIALS, NAMELY, HEAT TREATMENT OF METAL MACHINE PARTS FOR THE PURPOSE OF HARDENING SAID METALS (U.S. CLS. 100, 103 AND 106).

MOTE CONTROL PASSIVE AND ACTIVE PEDALS, AMPLIFIER CONTROLS FOR VOLUME, TONE AND EFFECTS (U.S. CLS. 21, 23, 26, 36 AND 38).

FIRST USE 12-1-1986; IN COMMERCE 12-1-1986.

#### CLASS 15—MUSICAL INSTRUMENTS

FOR MUSIC SYNTHESIZERS, MUSIC CONTROLLERS AND GUITAR INPUT DEVICES, ELECTRIC GUITARS, ELECTRONIC GUITARS, VIRTUAL GUITARS, ELECTRONIC DRUM AND PERCUSSION MACHINES; ELECTRONIC PIANOS, ELECTRONIC ORGANS AND RHYTHM MACHINES, NAMELY, INSTRUMENTS; MUSICAL KEYBOARDS, AND ELECTRIC GUITARS AND PARTS THEREFOR, ACCESSORIES FOR GUITARS SUCH AS CASES, BAGS, STRAPS, PICKS, BELTS, STANDS, HANDLES, STRINGS SOLD AS A UNIT WITH GUITARS AND PARTS THEREFOR (U.S. CLS. 2, 21 AND 36).

FIRST USE 12-1-1986; IN COMMERCE 12-1-1986.  
STEPHANIE ALI, EXAMINING ATTORNEY

SN 77-801,723. LOUISIANA TANK, INC., LAKE CHARLES, LA. FILED 8-11-2009.



NO CLAIM IS MADE TO THE EXCLUSIVE RIGHT TO USE "TANK", APART FROM THE MARK AS SHOWN.

THE COLOR(S) ARE RED AND WHITE IS/ARE CLAIMED AS A FEATURE OF THE MARK.

THE MARK CONSISTS OF A RECTANGLE SLIGHTLY TALLER THAN WIDE. THE UPPER 2/3RDS OF THE RECTANGLE IS OUTLINED IN RED WITH ROUNDED CORNERS. THE BACKGROUND OF THE UPPER 2/3RDS OF THE RECTANGLE IS WHITE. THE INITIALS "LA" IS IN RED AND IS LOCATED IN THE UPPER 2/3RDS OF THE RECTANGLE. THE BOTTOM 1/3RD OF THE RECTANGLE IS ALL IN RED EXCEPT THE WORD "TANK" IS IN WHITE.  
SEC. 2(F).

#### CLASS 1—CHEMICALS

FOR OIL RECLAMATION FLUID FOR THE SEPARATION OF CRUDE OIL FROM SOIL AND WATER (U.S. CLS. 1, 5, 6, 10, 26 AND 46).

FIRST USE 9-16-1976; IN COMMERCE 9-16-1976.

#### CLASS 4—LUBRICANTS AND FUELS

FOR CRUDE OIL (U.S. CLS. 1, 6 AND 15).  
FIRST USE 9-16-1976; IN COMMERCE 9-16-1976.

#### CLASS 7—MACHINERY

FOR OIL SEPARATORS (U.S. CLS. 13, 19, 21, 23, 31, 34 AND 35).

FIRST USE 9-16-1976; IN COMMERCE 9-16-1976.

#### CLASS 37—CONSTRUCTION AND REPAIR

FOR HAZARDOUS WASTE DISPOSAL SERVICES (U.S. CLS. 100, 103 AND 106).

FIRST USE 9-16-1976; IN COMMERCE 9-16-1976.

#### CLASS 39—TRANSPORTATION AND STORAGE

FOR HAZARDOUS WASTE TRANSPORTATION SERVICES; TANKER TRANSPORT; TRANSMISSION OF OIL OR GAS THROUGH PIPELINES; TRANSPORTATION AND STORAGE OF FUELS (U.S. CLS. 100 AND 105).

FIRST USE 9-16-1976; IN COMMERCE 9-16-1976.

ERIN FALK, EXAMINING ATTORNEY

SN 77-807,126. KEYPOINT GOVERNMENT SOLUTIONS, INC., LOVELAND, CO. FILED 8-18-2009.



NO CLAIM IS MADE TO THE EXCLUSIVE RIGHT TO USE "GOVERNMENT SOLUTIONS", APART FROM THE MARK AS SHOWN.

THE COLOR(S) LIGHT BLUE AND DARK BLUE IS/ARE CLAIMED AS A FEATURE OF THE MARK.

THE MARK CONSISTS OF THE COLOR LIGHT BLUE APPEARING IN THE BOTTOM LEFT PORTION OF THE STAR DESIGN AND THE TERMS "GOVERNMENT SOLUTIONS" AND THE COLOR DARK BLUE APPEARING IN THE REMAINDER OF THE STAR DESIGN AND THE TERM "KEYPOINT".

#### CLASS 35—ADVERTISING AND BUSINESS

FOR BUSINESS INVESTIGATIONS, NAMELY, CORPORATE AND AGENCY GOVERNANCE INVESTIGATIONS; GOVERNMENT CONTRACTOR ADVISORY SERVICES, NAMELY, CONSULTING IN THE FIELD OF BUSINESS FINANCIAL AUDITING; ANTI-MONEY LAUNDERING PROGRAMS, NAMELY, BUSINESS AUDITS AND INVESTIGATIONS; FORENSIC ACCOUNTING (U.S. CLS. 100, 101 AND 102).

FIRST USE 9-9-2009; IN COMMERCE 9-9-2009.

#### CLASS 36—INSURANCE AND FINANCIAL

FOR FINANCIAL INVESTIGATIONS, NAMELY, ASSET TRACING OF PERSONAL AND CORPORATE ASSETS; EVALUATION OF CREDIT BUREAU DATA FOR OTHERS; INVESTIGATIVE FINANCIAL DUE DILIGENCE (U.S. CLS. 100, 101 AND 102).

FIRST USE 9-9-2009; IN COMMERCE 9-9-2009.

#### CLASS 41—EDUCATION AND ENTERTAINMENT

FOR BIOMETRIC CAPTURE, PROCESSING AND EVALUATION, NAMELY, PHOTOGRAPHY (U.S. CLS. 100, 101 AND 107).

FIRST USE 9-9-2009; IN COMMERCE 9-9-2009.

#### CLASS 42—SCIENTIFIC AND COMPUTER SERVICES

FOR GOVERNMENT CONTRACTOR ADVISORY SERVICES, NAMELY, CONSULTING IN THE FIELD OF CYBER AND INFORMATION COMPUTER SECURITY (U.S. CLS. 100 AND 101).

FIRST USE 9-9-2009; IN COMMERCE 9-9-2009.

**CLASS 45—PERSONAL AND LEGAL SERVICES**

FOR PROVIDING BACKGROUND INVESTIGATIONS, PROVIDING NATIONAL SECURITY AND BACKGROUND RESEARCH SERVICES; PROVIDING INFORMATION VIA AN ON-LINE DATABASE FOR SECURITY AND BACKGROUND CLEARANCE INVESTIGATIONS; PROVIDING PUBLIC RECORDS INFORMATION FOR THE PURPOSE OF CONDUCTING CRIMINAL BACKGROUND AND SECURITY CLEARANCE INVESTIGATIONS IN THE FORM OF AN ONLINE DATABASE; PROVIDING A DATABASE FEATURING BACKGROUND SCREENING INFORMATION; EXPERT WITNESS SERVICES IN LEGAL MATTERS IN THE FIELD OF CRIMINAL JUSTICE, BACKGROUND INVESTIGATIONS AND SECURITY CLEARANCE INVESTIGATIONS; SECURITY DUE DILIGENCE SERVICES FOR INDIVIDUALS OR BUSINESSES TRAVELING OR OPENING AN OFFICE OVERSEAS, IN THE NATURE OF DETAILED FOREIGN COUNTRY BRIEFINGS, VETTING OF LOCAL PERSONNEL, ESTABLISHING HOST COUNTRY GOVERNMENT CONTRACTS, AND PROVIDING INFORMATION ON SUSTAINABLE SECURITY MEASURES OVERSEAS; ELECTRONIC LEGAL DISCOVERY CONSULTING SERVICES IN THE FIELD OF NATIONAL SECURITY; DOCUMENT GATHERING, NAMELY, GATHERING PERSONAL VITAL RECORDS AND CRIMINAL AND CIVIL CASE HISTORIES; INVESTIGATIONS SERVICES, NAMELY, PRE-EMPLOYMENT BACKGROUND INVESTIGATIONS, NATIONAL SECURITY BACKGROUND INVESTIGATIONS; BIOMETRIC CAPTURE, PROCESSING AND EVALUATION, NAMELY, FINGERPRINTING; GOVERNMENT CONTRACTOR ADVISORY SERVICES, NAMELY, CONSULTING IN THE FIELD OF PHYSICAL SECURITY AND CONSULTING IN THE FIELD INFORMATION SECURITY WHERE THE INFORMATION IS PHYSICAL; COMPLIANCE MONITORING, NAMELY, TRACKING AND MONITORING COMPLIANCE WITH POLICIES, LAWS AND REGULATIONS IN THE FIELD OF NATIONAL SECURITY, PHYSICAL SECURITY AND CRIMINAL JUSTICE (U.S. CLS. 100 AND 101).

FIRST USE 9-9-2009; IN COMMERCE 9-9-2009.  
SUNG IN, EXAMINING ATTORNEY

SN 77-807,149, KEYPOINT GOVERNMENT SOLUTIONS, INC., LOVELAND, CO. FILED 8-18-2009.

# KEYPOINT

THE MARK CONSISTS OF STANDARD CHARACTERS WITHOUT CLAIM TO ANY PARTICULAR FONT, STYLE, SIZE, OR COLOR.

**CLASS 35—ADVERTISING AND BUSINESS**

FOR BUSINESS INVESTIGATIONS, NAMELY, CORPORATE AND AGENCY GOVERNANCE INVESTIGATIONS; GOVERNMENT CONTRACTOR ADVISORY SERVICES, NAMELY, CONSULTING IN THE FIELD OF BUSINESS FINANCIAL AUDITING; ANTI-MONEY LAUNDERING PROGRAMS, NAMELY, BUSINESS AUDITS AND INVESTIGATIONS; FORENSIC ACCOUNTING (U.S. CLS. 100, 101 AND 102).

FIRST USE 9-9-2009; IN COMMERCE 9-9-2009.

**CLASS 36—INSURANCE AND FINANCIAL**

FOR FINANCIAL INVESTIGATIONS, NAMELY, ASSET TRACING OF PERSONAL AND CORPORATE ASSETS; EVALUATION OF CREDIT BUREAU DATA FOR OTHERS; INVESTIGATIVE FINANCIAL DUE DILIGENCE (U.S. CLS. 100, 101 AND 102).

FIRST USE 9-9-2009; IN COMMERCE 9-9-2009.

**CLASS 41—EDUCATION AND ENTERTAINMENT**

FOR BIOMETRIC CAPTURE, PROCESSING AND EVALUATION, NAMELY, PHOTOGRAPHY (U.S. CLS. 100, 101 AND 107).

FIRST USE 9-9-2009; IN COMMERCE 9-9-2009.

**CLASS 42—SCIENTIFIC AND COMPUTER SERVICES**

FOR GOVERNMENT CONTRACTOR ADVISORY SERVICES, NAMELY, CONSULTING IN THE FIELD OF CYBER AND INFORMATION COMPUTER SECURITY (U.S. CLS. 100 AND 101).

FIRST USE 9-9-2009; IN COMMERCE 9-9-2009.

**CLASS 45—PERSONAL AND LEGAL SERVICES**

FOR PROVIDING BACKGROUND INVESTIGATIONS, PROVIDING NATIONAL SECURITY AND BACKGROUND RESEARCH SERVICES; PROVIDING INFORMATION VIA AN ON-LINE DATABASE FOR SECURITY AND BACKGROUND CLEARANCE INVESTIGATIONS; PROVIDING PUBLIC RECORDS INFORMATION FOR THE PURPOSE OF CONDUCTING CRIMINAL BACKGROUND AND SECURITY CLEARANCE INVESTIGATIONS IN THE FORM OF AN ONLINE DATABASE; PROVIDING A DATABASE FEATURING BACKGROUND SCREENING INFORMATION; EXPERT WITNESS SERVICES IN LEGAL MATTERS IN THE FIELD OF CRIMINAL JUSTICE, BACKGROUND INVESTIGATIONS AND SECURITY CLEARANCE INVESTIGATIONS; SECURITY DUE DILIGENCE SERVICES FOR INDIVIDUALS OR BUSINESSES TRAVELING OR OPENING AN OFFICE OVERSEAS, IN THE NATURE OF DETAILED FOREIGN COUNTRY BRIEFINGS, VETTING OF LOCAL PERSONNEL, ESTABLISHING HOST COUNTRY GOVERNMENT CONTRACTS, AND PROVIDING INFORMATION ON SUSTAINABLE SECURITY MEASURES OVERSEAS; ELECTRONIC LEGAL DISCOVERY CONSULTING SERVICES IN THE FIELD OF NATIONAL SECURITY; DOCUMENT GATHERING, NAMELY, GATHERING PERSONAL VITAL RECORDS AND CRIMINAL AND CIVIL CASE HISTORIES; INVESTIGATIONS SERVICES, NAMELY, PRE-EMPLOYMENT BACKGROUND INVESTIGATIONS, NATIONAL SECURITY BACKGROUND INVESTIGATIONS; BIOMETRIC CAPTURE, PROCESSING AND EVALUATION, NAMELY, FINGERPRINTING; GOVERNMENT CONTRACTOR ADVISORY SERVICES, NAMELY, CONSULTING IN THE FIELD OF PHYSICAL SECURITY AND CONSULTING IN THE FIELD INFORMATION SECURITY WHERE THE INFORMATION IS PHYSICAL; COMPLIANCE MONITORING, NAMELY, TRACKING AND MONITORING COMPLIANCE WITH POLICIES, LAWS AND REGULATIONS IN THE FIELD OF NATIONAL SECURITY, PHYSICAL SECURITY AND CRIMINAL JUSTICE (U.S. CLS. 100 AND 101).

FIRST USE 9-9-2009; IN COMMERCE 9-9-2009.

SUNG IN, EXAMINING ATTORNEY

SN 77-807,152, KEYPOINT GOVERNMENT SOLUTIONS, INC., LOVELAND, CO. FILED 8-18-2009.

# KEYPOINT GOVERNMENT SOLUTIONS

THE MARK CONSISTS OF STANDARD CHARACTERS WITHOUT CLAIM TO ANY PARTICULAR FONT, STYLE, SIZE, OR COLOR.

NO CLAIM IS MADE TO THE EXCLUSIVE RIGHT TO USE "GOVERNMENT SOLUTIONS", APART FROM THE MARK AS SHOWN.

**CLASS 35—ADVERTISING AND BUSINESS**

FOR BUSINESS INVESTIGATIONS, NAMELY, CORPORATE AND AGENCY GOVERNANCE INVESTIGATIONS; GOVERNMENT CONTRACTOR ADVISORY SERVICES, NAMELY, CONSULTING IN THE FIELD OF BUSINESS FINANCIAL AUDITING; ANTI-MONEY LAUNDERING PROGRAMS, NAMELY, BUSINESS AUDITS AND INVESTIGATIONS; FORENSIC ACCOUNTING (U.S. CLS. 100, 101 AND 102).

FIRST USE 9-9-2009; IN COMMERCE 9-9-2009.

**CLASS 36—INSURANCE AND FINANCIAL**

FOR FINANCIAL INVESTIGATIONS, NAMELY, ASSET TRACING OF PERSONAL AND CORPORATE ASSETS; EVALUATION OF CREDIT BUREAU DATA FOR OTHERS; INVESTIGATIVE FINANCIAL DUE DILIGENCE (U.S. CLS. 100, 101 AND 102).

FIRST USE 9-9-2009; IN COMMERCE 9-9-2009.

**CLASS 41—EDUCATION AND ENTERTAINMENT**

FOR BIOMETRIC CAPTURE, PROCESSING AND EVALUATION, NAMELY, PHOTOGRAPHY (U.S. CLS. 100, 101 AND 107).

FIRST USE 9-9-2009; IN COMMERCE 9-9-2009.

**CLASS 42—SCIENTIFIC AND COMPUTER SERVICES**

FOR GOVERNMENT CONTRACTOR ADVISORY SERVICES, NAMELY, CONSULTING IN THE FIELD OF CYBER AND INFORMATION COMPUTER SECURITY (U.S. CLS. 100 AND 101).

FIRST USE 9-9-2009; IN COMMERCE 9-9-2009.

**CLASS 45—PERSONAL AND LEGAL SERVICES**

FOR PROVIDING BACKGROUND INVESTIGATIONS, PROVIDING NATIONAL SECURITY AND BACKGROUND RESEARCH SERVICES; PROVIDING INFORMATION VIA AN ON-LINE DATABASE FOR SECURITY AND BACKGROUND CLEARANCE INVESTIGATIONS; PROVIDING PUBLIC RECORDS INFORMATION FOR THE PURPOSE OF CONDUCTING CRIMINAL BACKGROUND AND SECURITY CLEARANCE INVESTIGATIONS IN THE FORM OF AN ONLINE DATABASE; PROVIDING A DATABASE FEATURING BACKGROUND SCREENING INFORMATION; EXPERT WITNESS SERVICES IN LEGAL MATTERS IN THE FIELD OF CRIMINAL JUSTICE, BACKGROUND INVESTIGATIONS AND SECURITY CLEARANCE INVESTIGATIONS; SECURITY DUE DILIGENCE SERVICES FOR INDIVIDUALS OR BUSINESSES TRAVELING OR OPENING AN OFFICE OVERSEAS, IN THE NATURE OF DETAILED FOREIGN COUNTRY BRIEFINGS, VETTING OF LOCAL PERSONNEL, ESTABLISHING HOST COUNTRY GOVERNMENT CONTRACTS, AND PROVIDING INFORMATION ON SUSTAINABLE SECURITY MEASURES OVERSEAS; ELECTRONIC LEGAL DISCOVERY CONSULTING SERVICES IN THE FIELD OF NATIONAL SECURITY; DOCUMENT GATHERING, NAMELY, GATHERING PERSONAL VITAL RECORDS AND CRIMINAL AND CIVIL CASE HISTORIES; INVESTIGATIONS SERVICES, NAMELY, PRE-EMPLOYMENT BACKGROUND INVESTIGATIONS, NATIONAL SECURITY BACKGROUND INVESTIGATIONS; BIOMETRIC CAPTURE, PROCESSING AND EVALUATION, NAMELY, FINGERPRINTING; GOVERNMENT CONTRACTOR ADVISORY SERVICES, NAMELY, CONSULTING IN THE FIELD OF PHYSICAL SECURITY AND CONSULTING IN THE FIELD INFORMATION SECURITY WHERE THE INFORMATION IS PHYSICAL; COMPLIANCE MONITORING, NAMELY, TRACKING AND MONITORING COMPLIANCE WITH POLICIES, LAWS AND REGULATIONS IN THE FIELD OF NATIONAL SECURITY, PHYSICAL SECURITY AND CRIMINAL JUSTICE (U.S. CLS. 100 AND 101).

FIRST USE 9-9-2009; IN COMMERCE 9-9-2009.  
SUNG IN, EXAMINING ATTORNEY

SN 77-807,426. ZONIT STRUCTURED SOLUTIONS LLC, BOULDER, CO. FILED 8-18-2009.

# COOL-ZONIT

THE MARK CONSISTS OF STANDARD CHARACTERS WITHOUT CLAIM TO ANY PARTICULAR FONT, STYLE, SIZE, OR COLOR.

**CLASS 9—ELECTRICAL AND SCIENTIFIC APPARATUS**

FOR DATA CENTER EQUIPMENT, NAMELY, SYSTEMS COMPRISED OF TEMPERATURE CONTROLLERS AND ASSOCIATED EXTERNAL COOLING FANS AND AIR-BASED COOLING CONDUITS FOR COOLING DATA CENTERS, DATA CENTER RACKS, AND ELECTRONIC DEVICES THEREIN (U.S. CLS. 21, 23, 26, 31 AND 38).

**CLASS 42—SCIENTIFIC AND COMPUTER SERVICES**

FOR DATA CENTER EQUIPMENT SERVICES, NAMELY, DESIGN FOR OTHERS IN THE FIELD OF DATA CENTER EQUIPMENT IN THE NATURE OF CONFIGURING DATA CENTERS AND EQUIPMENT WITHIN RACKS FOR ENHANCED COOLING OF ELECTRONIC DATA EQUIPMENT (U.S. CLS. 100 AND 101).  
CHRISTINA SOBRAL, EXAMINING ATTORNEY

SN 77-809,130. NATURAL BODY INTERNATIONAL, INC., ATLANTA, GA. FILED 8-20-2009.



OWNER OF U.S. REG. NOS. 1,706,141, 2,240,421 AND OTHERS.

NO CLAIM IS MADE TO THE EXCLUSIVE RIGHT TO USE "SPA AND SHOP" FOR INTERNATIONAL CLASS 3 AND "BODY" FOR INTERNATIONAL CLASS 3, 35 AND 44 AND "SPA AND SHOP" FOR INTERNATIONAL CLASSES 35 AND 44, APART FROM THE MARK AS SHOWN.

THE MARK CONSISTS OF THE LETTER "N" INSIDE OF A BOX WITH A LEAF ON TOP OF THE LEFT STEM IN THE LETTER "N" AND A LEAF AT THE BOTTOM RIGHT LEG OF THE LETTER "N". THE WORDS "NATURAL BODY" UNDER THE DESIGN AND THE WORDS "SPA AND SHOP" ARE UNDERNEATH THAT.

**CLASS 3—COSMETICS AND CLEANING PREPARATIONS**

FOR SOAP, SHAMPOO, HAIR CONDITIONER, SHOWER GEL, BUBBLE BATH, FACIAL CREAM, HAND CREAM, BODY LOTION, TALCUM POWDER AND PERFUME (U.S. CLS. 1, 4, 6, 50, 51 AND 52).

FIRST USE 6-1-2008; IN COMMERCE 6-1-2008.

**CLASS 35—ADVERTISING AND BUSINESS**

FOR RETAIL STORE SERVICES FEATURING SKIN AND BODY CARE PRODUCTS (U.S. CLS. 100, 101 AND 102).

FIRST USE 6-1-2008; IN COMMERCE 6-1-2008.

**CLASS 44—MEDICAL, BEAUTY AND AGRICULTURAL SERVICES**

FOR HEALTH SPAS FEATURING AROMATHERAPY, FACIALS, MASSAGES, BODY WRAPS, STRESS THERAPY, MANICURES AND PEDICURES, AYURVEDIC TREATMENTS, BODY POLISH, AND GENERAL WELLNESS CONSULTATION (U.S. CLS. 100 AND 101).

FIRST USE 6-1-2008; IN COMMERCE 6-1-2008.

MICHELLE DUBOIS, EXAMINING ATTORNEY

**CLASS 5—PHARMACEUTICALS**

FOR EYE DROPS; HYDROCORTISONE CREAMS; DIETARY SUPPLEMENTS; VITAMIN SUPPLEMENTS; ANTISEPTIC; ASPIRIN; NASAL DECONGESTANTS; MEDICATED MOUTHWASH; ASPIRIN FREE CAPSULES, NAMELY, IBUPROFEN FOR USE AS AN ORAL ANALGESIC; ANTI-DIARRHEA MEDICATION; PAIN RELIEF MEDICATION; MULTIVITAMIN PREPARATIONS; NON-ASPIRIN ACETAMINOPHEN CAPLETS; TOPICAL FIRST AID REMEDY OINTMENT; ACETAMINOPHEN GEL TABS; COUGH SYRUP; EXPECTORANTS; ANTIHISTAMINES; PREPARATIONS FOR TREATING FEVER, COLD AND FLU; DENTAL RINSE; LAXATIVE; DIETARY SUPPLEMENTS; ADULT INCONTINENCE GARMENTS; ANTACIDS AND ANTI-GAS TABLETS; VAGINAL PREPARATIONS, NAMELY, ANTI FUNGAL CREAMS; PAIN RELIEF MEDICATION, ALLERGY AND SINUS MEDICATIONS; SLEEPING PILLS; BANDAGE STRIPS FOR SKIN WOUNDS; ATHLETES FOOT CREAM; COUGH DROPS; PANTY LINERS; NAPROXEN SODIUM CAPLETS; NASAL SPRAYS; HEMORRHOID TREATMENT OINTMENT; LIQUID MAGNESIA PREPARATION FOR THE TREATMENT OF SOUR STOMACH; HERBAL SUPPLEMENTS; PETROLEUM JELLY FOR MEDICAL PURPOSES; ANALGESICS; DECONGESTANTS; CALAMINE ANTI-ITCH LOTION; STERILE PADS IN THE NATURE OF WOUND DRESSINGS; LAXATIVE SUPPOSITORY; ANTI-ARTHRITIC COMPOSITIONS AND PREPARATIONS; ENEMAS; GAUZE ROLL; BISMUTH PREPARATIONS FOR PHARMACEUTICAL PURPOSES; DENTURE ADHESIVE; SORE THROAT ANESTHETIC AND SPRAYS; ANTI-ITCH CREAM; VAGINAL SUPPOSITORIES; LYSINE AMINO ACID PREPARATIONS; DISPOSABLE DOUCHE; MEDICATED FOOT POWDER; DIET AID PILLS; MEDICATED CHEST RUB; SANITIZING WIPES; CHEST CONGESTION RELIEF PREPARATIONS; STOOL SOFTENER; GELS USED FOR PERSONAL LUBRICANT; PHARMACEUTICAL PREPARATION FOR THE RELIEF OF THROAT AND MOUTH SORENESS (U.S. CLS. 6, 18, 44, 46, 51 AND 52).

SN 77-813,448. THE GREAT ATLANTIC & PACIFIC TEA COMPANY, INC., MONTVALE, NJ. FILED 8-26-2009.

**CLASS 21—HOUSEWARES AND GLASS**

FOR DENTAL FLOSS; DENTAL TAPE (U.S. CLS. 2, 13, 23, 29, 30, 33, 40 AND 50).

**CLASS 25—CLOTHING**

FOR FOOT CARE DEVICE IN THE NATURE OF INSOLES, NAMELY, GEL INSOLES, BAMBOO INSOLES, FOAM INSOLES, BALL OF FOOT INSOLES, HEEL LINER, ODOR STOPPER INSOLES, OPEN STYLE INSOLES AND MOLE FOAM PADDING INSOLES (U.S. CLS. 22 AND 39).

LAURA KOVALSKY, EXAMINING ATTORNEY

**LIVE BETTER**

SN 77-813,710. FUEL SAVING TECHNOLOGIES, LLC, HONOLULU, HI. FILED 8-27-2009.

THE MARK CONSISTS OF STANDARD CHARACTERS WITHOUT CLAIM TO ANY PARTICULAR FONT, STYLE, SIZE, OR COLOR.

OWNER OF U.S. REG. NOS. 3,452,346 AND 3,491,210.

**CLASS 3—COSMETICS AND CLEANING PREPARATIONS**

FOR COTTON SWABS FOR COSMETIC PURPOSES; DENTURE CLEANERS; PETROLEUM JELLY FOR COSMETIC PURPOSES; NON-MEDICATED BABY OINTMENT FOR THE PREVENTION AND TREATMENT OF DIAPER RASH; BABY BATH LIQUID SOAP; COTTON PUFFS FOR COSMETIC PURPOSES; TOOTHPASTE; BREATH FRESHENER; DENTIFRICES IN THE FORM OF CHEWING GUM; LIP BALM; NON-MEDICATED MOUTHWASH; NON-MEDICATED FOOT POWDER (U.S. CLS. 1, 4, 6, 50, 51 AND 52).

**PULSED CRUISE**

THE MARK CONSISTS OF STANDARD CHARACTERS WITHOUT CLAIM TO ANY PARTICULAR FONT, STYLE, SIZE, OR COLOR.

**CLASS 9—ELECTRICAL AND SCIENTIFIC APPARATUS**

FOR ELECTRONIC CONTROL SYSTEMS FOR GASOLINE ENGINES FOR PROVIDING VEHICLE FUEL AND ENERGY MANAGEMENT; AND ELECTRONIC CONTROL SYSTEMS FOR MACHINES FOR PROVIDING FUEL AND ENERGY MANAGEMENT (U.S. CLS. 21, 23, 26, 36 AND 38).

**CLASS 12—VEHICLES**

FOR MOTORIZED VEHICLES, NAMELY, MOTORIZED LAND, WATER AND AIR VEHICLES (U.S. CLS. 19, 21, 23, 31, 35 AND 44).

MARK T. MULLEN, EXAMINING ATTORNEY

SN 77-815,896. BAISDEN MEDIA GROUP, LLC, DALLAS, TX. FILED 8-29-2009.

**MINGLE CITY**

THE MARK CONSISTS OF STANDARD CHARACTERS WITHOUT CLAIM TO ANY PARTICULAR FONT, STYLE, SIZE, OR COLOR.

**CLASS 35—ADVERTISING AND BUSINESS**

FOR ADVERTISING AND INFORMATION DISTRIBUTION SERVICES, NAMELY, PROVIDING ADVERTISING SPACE VIA A GLOBAL COMPUTER NETWORK; ADVERTISING AND MARKETING SERVICES, NAMELY, PROMOTING THE GOODS AND SERVICES OF OTHERS; ELECTRONIC COMMERCE SERVICES, NAMELY, PROVIDING INFORMATION ABOUT PRODUCTS VIA TELECOMMUNICATION NETWORKS FOR ADVERTISING AND SALES PURPOSES; PROMOTING THE PARTIES AND SPECIAL EVENTS OF OTHERS; PROVIDING AN ON-LINE COMPUTER DATABASE FEATURING TRADE INFORMATION IN THE FIELDS OF CLASSIFIED LISTINGS AND WANT ADS; PROVIDING AN ON-LINE SEARCHABLE DATABASE FEATURING CLASSIFIED AD LISTINGS AND EMPLOYMENT OPPORTUNITIES; ONLINE RETAIL STORE SERVICES FEATURING MUSIC, MOVIES, EVENT TICKETS, AND CLOTHING; ONLINE RETAIL STORE SERVICES FEATURING PRODUCTS IN THE FIELDS OF MUSIC AND ENTERTAINMENT, NAMELY, MUSIC AND ENTERTAINMENT VIDEOS; ADVERTISING AND MARKETING SERVICES, NAMELY, PROVIDING AN INTERNET WEBSITE PORTAL FEATURING LINKS TO WEBSITES TO PROMOTE THE GOODS AND SERVICES OF OTHERS FROM A WIDE VARIETY OF BUSINESSES (U.S. CLS. 100, 101 AND 102).

FIRST USE 9-25-2005; IN COMMERCE 9-25-2005.

**CLASS 38—COMMUNICATION**

FOR PROVIDING ONLINE CHAT ROOMS AND ELECTRONIC BULLETIN BOARDS FOR TRANSMISSION OF MESSAGES AMONG USERS IN THE FIELDS OF GENERAL INTEREST, SOCIAL NETWORKING, CLASSIFIEDS, AND VIRTUAL COMMUNITY; PROVIDING EMAIL AND INSTANT MESSAGING SERVICES; AUDIO AND VIDEO BROADCASTING SERVICES OVER THE INTERNET OR OTHER COMMUNICATIONS NETWORK, NAMELY, ELECTRONICALLY TRANSMITTING INFORMATION, AUDIO CLIPS, AND VIDEO CLIPS; PROVIDING ACCESS TO COMPUTER DATABASES; ELECTRONIC TRANSMISSION OF INSTANT MESSAGES AND DATA; PROVIDING ONLINE COMPUTER DATABASES AND ON-LINE SEARCHABLE DATABASES IN THE FIELDS OF TRANSMISSION OF PHOTOGRAPHIC IMAGES AND PROVISION OF ONLINE FORUMS FOR COMMUNICATION ON TOPICS OF

GENERAL INTEREST; PROVIDING ACCESS TO ELECTRONIC SITES FOR INFORMATION, AUDIO, AND VIDEO VIA WEBSITES, ONLINE FORUMS, CHAT ROOMS, ELECTRONIC MAILING LISTS AND BLOGS OVER THE INTERNET; TEXT AND NUMERIC WIRELESS DIGITAL MESSAGING SERVICES; COMMUNICATION SERVICES, NAMELY, TRANSMISSION OF VOICE, AUDIO, VISUAL IMAGES AND DATA BY TELECOMMUNICATIONS NETWORKS, WIRELESS COMMUNICATION NETWORKS, THE INTERNET, INFORMATION SERVICES NETWORKS AND DATA NETWORKS; PROVIDING VOICE COMMUNICATION SERVICES OVER THE INTERNET; PROVIDING ONLINE CHAT ROOMS FOR TRANSMISSION OF MESSAGES AMONG COMPUTER USERS CONCERNING INFORMATION IN THE FIELDS OF GENERAL INTEREST, SOCIAL NETWORKING, CLASSIFIEDS, AND VIRTUAL COMMUNITY; TELECOMMUNICATION SERVICES, NAMELY, WORLDWIDE SWITCHED TEXT AND MESSAGE TRANSMISSION SERVICES, ELECTRONIC MESSAGE SENDING AND OUTCALL NOTIFICATION SERVICES; ELECTRONIC DATA TRANSMISSION, NAMELY, PROVIDING TRANSMISSION SERVICES VIA MOBILE DEVICES TO LOOK UP USER PROFILE INFORMATION, SEARCH FOR USERS, SEND MESSAGES TO USERS, POST INFORMATION VIEWABLE BY USERS, ADD CONTACTS, AND PROVIDE NOTIFICATIONS (U.S. CLS. 100, 101 AND 104).

FIRST USE 9-25-2005; IN COMMERCE 9-25-2005.

**CLASS 41—EDUCATION AND ENTERTAINMENT**

FOR ARRANGING AND CONDUCTING SPECIAL EVENTS FOR SOCIAL ENTERTAINMENT PURPOSES; ENTERTAINMENT SERVICES, NAMELY, PROVIDING A WEB SITE FEATURING MUSICAL PERFORMANCES, MUSICAL VIDEOS, RELATED FILM CLIPS, PHOTOGRAPHS, AND OTHER MULTIMEDIA MATERIALS IN THE FIELDS OF RELATIONSHIPS, BUSINESS, HEALTH, BOOKS, MUSIC, AND POLITICS; ENTERTAINMENT SERVICES, NAMELY, PROVIDING AN ELECTRONIC NEWSLETTER IN THE FIELDS OF RELATIONSHIPS, BUSINESS, HEALTH, BOOKS, MUSIC, AND POLITICS; ENTERTAINMENT SERVICES, NAMELY, PROVIDING A WEB SITE FEATURING USER-GENERATED VIDEOS ON A VARIETY OF TOPICS AND SUBJECTS; ENTERTAINMENT SERVICES, NAMELY, PROVIDING A WEBSITE AT WHICH THE GENERAL PUBLIC CAN RECEIVE ADVICE AND COUNSEL IN THE FIELDS OF RELATIONSHIPS FOR ENTERTAINMENT PURPOSES ONLY; ENTERTAINMENT SERVICES, NAMELY, PROVIDING NON-DOWNLOADABLE PRERECORDED MUSIC AND INFORMATION IN THE FIELDS OF MUSIC, COMMENTARY, AND ARTICLES ABOUT MUSIC, ALL ONLINE VIA A GLOBAL COMPUTER NETWORK; PROVIDING INFORMATION, NEWS, AND COMMENTARY IN THE FIELD OF ENTERTAINMENT; SPECIAL EVENT PLANNING; ENTERTAINMENT SERVICES IN THE NATURE OF LIVE MUSICAL PERFORMANCES; ENTERTAINMENT SERVICES, NAMELY, PERSONAL APPEARANCES BY A NATIONALLY SYNDICATED RADIO PERSONALITY, BEST-SELLING AUTHOR, AND MOTIVATIONAL SPEAKER; ENTERTAINMENT SERVICES, NAMELY, PROVIDING A RADIO PROGRAM IN THE FIELDS OF RELATIONSHIPS, BUSINESS, HEALTH, BOOKS, MUSIC, AND POLITICS VIA A GLOBAL COMPUTER NETWORK; ENTERTAINMENT SERVICES IN THE NATURE OF AN ONGOING TELEVISION PROGRAM IN THE FIELD OF RELATIONSHIPS, BUSINESS, HEALTH, BOOKS, MUSIC, AND POLITICS VIA A GLOBAL COMPUTER NETWORK; ENTERTAINMENT SERVICES, NAMELY, PROVIDING ONLINE REVIEWS OF BOOKS, MUSIC, TV, FILM, MOVIES, SHOW TOPICS, AND COMPUTER GAMES; ONLINE JOURNALS, NAMELY, BLOGS FEATURING DISCUSSIONS ABOUT BOOKS, MUSIC, RADIO SHOW TOPICS, SOCIAL ENTERTAINMENT TOPICS, FAN CLUBS, EVENTS, POEMS, AND INTERVIEWS; PRODUCTION OF RADIO OR TELEVISION PROGRAMS; PROVIDING A WEB SITE WHERE USERS CAN POST RATINGS, REVIEWS, AND RECOMMENDATIONS ON EVENTS AND ACTIVITIES IN THE FIELD OF ENTERTAINMENT AND EDUCATION; RADIO ENTERTAINMENT SERVICES, NAMELY, RADIO PROGRAMS FEATURING PERFORMANCES BY A NATIONALLY SYNDICATED RADIO PERSONALITY, BEST-SELLING AUTHOR, AND MOTIVATIONAL

SPEAKER; TICKET RESERVATION AND BOOKING SERVICES FOR ENTERTAINMENT, SPORTING, AND CULTURAL EVENTS; ENTERTAINMENT SERVICES, NAMELY, CONDUCTING PARTIES FOR THE PURPOSE OF DATING AND SOCIAL INTRODUCTION FOR ADULTS (U.S. CLS. 100, 101 AND 107).

FIRST USE 9-25-2005; IN COMMERCE 9-25-2005.

#### **CLASS 42—SCIENTIFIC AND COMPUTER SERVICES**

FOR COMPUTER SERVICES IN THE NATURE OF CUSTOMIZED WEB PAGES FEATURING USER-DEFINED INFORMATION, PERSONAL PROFILES, AND MULTIMEDIA CONTENT; COMPUTER SERVICES, NAMELY, CREATING AN ONLINE COMMUNITY FOR REGISTERED USERS TO PARTICIPATE IN DISCUSSIONS, GET FEEDBACK FROM THEIR PEERS, AND ENGAGE IN SOCIAL NETWORKING; PROVIDING A WEB SITE FEATURING TEMPORARY USE OF NON-DOWNLOADABLE SOFTWARE ALLOWING WEB SITE USERS TO UPLOAD, POST, AND DISPLAY ONLINE VIDEOS FOR SHARING WITH OTHERS FOR ENTERTAINMENT AND INFORMATION PURPOSES; PROVIDING TEMPORARY USE OF NON-DOWNLOADABLE SOFTWARE APPLICATIONS FOR PHOTO SHARING, VIDEO SHARING, AND TRANSMISSION OF PHOTOGRAPHIC IMAGES; COMPUTER SERVICES, NAMELY, HOSTING ONLINE WEB FACILITIES FOR OTHERS FOR ORGANIZING AND CONDUCTING ONLINE MEETINGS, GATHERINGS, AND INTERACTIVE DISCUSSIONS; APPLICATION SERVICE PROVIDER FEATURING SOFTWARE TO ENABLE UPLOADING, POSTING, SHOWING, DISPLAYING, TAGGING, BLOGGING, SHARING OR OTHERWISE PROVIDING ELECTRONIC MEDIA OR INFORMATION OVER THE INTERNET OR OTHER COMMUNICATIONS NETWORK; PROVIDING A WEB SITE OVER THE INTERNET OR ELECTRONIC COMMUNICATIONS NETWORKS THAT GIVES COMPUTER USERS THE ABILITY TO TAG VIDEO CLIPS; PROVIDING TEMPORARY USE OF NON-DOWNLOADABLE SOFTWARE APPLICATIONS FOR CREATING AND POSTING CLASSIFIED ADVERTISEMENTS (U.S. CLS. 100 AND 101).

FIRST USE 9-25-2005; IN COMMERCE 9-25-2005.

#### **CLASS 45—PERSONAL AND LEGAL SERVICES**

FOR PROVIDING A SOCIAL NETWORKING WEBSITE FOR ENTERTAINMENT PURPOSES; PROVIDING ONLINE COMPUTER DATABASES AND ON-LINE SEARCHABLE DATABASES IN THE FIELD OF SOCIAL NETWORKING (U.S. CLS. 100 AND 101).

FIRST USE 9-25-2005; IN COMMERCE 9-25-2005.

CAROL SPILS, EXAMINING ATTORNEY

SN 77-815.906. BAISDEN MEDIA GROUP, LLC, DALLAS, TX. FILED 8-29-2009.



THE MARK CONSISTS OF THE LITERAL ELEMENT "MINGLE CITY" HAVING A PLURALITY OF TALL BUILDINGS ARCUATELY ARRANGED TO SIMULATE A TILTED CROWN OVER THE LETTER "M" AND THE LITERAL ELEMENT ".COM" RIGHT-JUSTIFIED THEREUNDER.

#### **CLASS 35—ADVERTISING AND BUSINESS**

FOR ADVERTISING AND INFORMATION DISTRIBUTION SERVICES, NAMELY, PROVIDING ADVERTISING SPACE VIA A GLOBAL COMPUTER NETWORK; ADVERTISING AND MARKETING SERVICES, NAMELY, PROMOTING THE GOODS AND SERVICES OF OTHERS; ELECTRONIC COMMERCE SERVICES, NAMELY, PROVIDING INFORMATION ABOUT PRODUCTS VIA TELECOMMUNICATION NETWORKS FOR ADVERTISING AND SALES PURPOSES; PROMOTING THE PARTIES AND SPECIAL EVENTS OF OTHERS; PROVIDING AN ON-LINE COMPUTER DATABASE FEATURING TRADE INFORMATION IN THE FIELDS OF CLASSIFIED LISTINGS AND WANT ADS; PROVIDING AN ON-LINE SEARCHABLE DATABASE FEATURING CLASSIFIED AD LISTINGS AND EMPLOYMENT OPPORTUNITIES; ONLINE RETAIL STORE SERVICES FEATURING MUSIC, MOVIES, EVENT TICKETS, AND CLOTHING; ONLINE RETAIL STORE SERVICES FEATURING PRODUCTS IN THE FIELDS OF MUSIC AND ENTERTAINMENT, NAMELY, MUSIC AND ENTERTAINMENT VIDEOS; ADVERTISING AND MARKETING SERVICES, NAMELY, PROVIDING AN INTERNET WEBSITE PORTAL FEATURING LINKS TO WEBSITES TO PROMOTE THE GOODS AND SERVICES OF OTHERS FROM A WIDE VARIETY OF BUSINESSES (U.S. CLS. 100, 101 AND 102).

FIRST USE 9-25-2005; IN COMMERCE 9-25-2005.

#### **CLASS 38—COMMUNICATION**

FOR PROVIDING ONLINE CHAT ROOMS AND ELECTRONIC BULLETIN BOARDS FOR TRANSMISSION OF MESSAGES AMONG USERS IN THE FIELDS OF GENERAL INTEREST, SOCIAL NETWORKING, CLASSIFIEDS, AND VIRTUAL COMMUNITY; PROVIDING EMAIL AND INSTANT MESSAGING SERVICES; AUDIO AND VIDEO BROADCASTING SERVICES OVER THE INTERNET OR OTHER COMMUNICATIONS NETWORK, NAMELY, ELECTRONICALLY TRANSMITTING INFORMATION, AUDIO CLIPS, AND VIDEO CLIPS; PROVIDING ACCESS TO COMPUTER DATABASES; ELECTRONIC TRANSMISSION OF INSTANT MESSAGES AND DATA; PROVIDING ONLINE COMPUTER DATABASES AND ON-LINE SEARCHABLE DATABASES IN THE FIELDS OF TRANSMISSION OF PHOTOGRAPHIC IMAGES AND PROVISION OF ONLINE FORUMS FOR COMMUNICATION ON TOPICS OF GENERAL INTEREST; PROVIDING ACCESS TO ELECTRONIC SITES FOR INFORMATION, AUDIO, AND VIDEO VIA WEBSITES, ONLINE FORUMS, CHAT ROOMS, ELECTRONIC MAILING LISTS AND BLOGS OVER THE INTERNET; TEXT AND NUMERIC WIRELESS DIGITAL MESSAGING SERVICES; COMMUNICATION SERVICES, NAMELY, TRANSMISSION OF VOICE, AUDIO, VISUAL IMAGES AND DATA BY TELECOMMUNICATIONS NETWORKS, WIRELESS COMMUNICATION NETWORKS, THE INTERNET, INFORMATION SERVICES NETWORKS AND DATA NETWORKS; PROVIDING VOICE COMMUNICATION SERVICES OVER THE INTERNET; PROVIDING ONLINE CHAT ROOMS FOR TRANSMISSION OF MESSAGES AMONG COMPUTER USERS CONCERNING INFORMATION IN THE FIELDS OF GENERAL INTEREST, SOCIAL NETWORKING, CLASSIFIEDS, AND VIRTUAL COMMUNITY; TELECOMMUNICATION SERVICES, NAMELY, WORLDWIDE SWITCHED TEXT AND MESSAGE TRANSMISSION SERVICES, ELECTRONIC MESSAGE SENDING AND OUTCALL NOTIFICATION SERVICES; ELECTRONIC DATA TRANSMISSION, NAMELY, PROVIDING TRANSMISSION SERVICES VIA MOBILE DEVICES TO LOOK UP USER PROFILE INFORMATION, SEARCH FOR USERS, SEND MESSAGES TO USERS, POST INFORMATION VIEWABLE BY USERS, ADD CONTACTS, AND PROVIDE NOTIFICATIONS (U.S. CLS. 100, 101 AND 104).

FIRST USE 9-25-2005; IN COMMERCE 9-25-2005.

**CLASS 41—EDUCATION AND ENTERTAINMENT**

FOR ARRANGING AND CONDUCTING SPECIAL EVENTS FOR SOCIAL ENTERTAINMENT PURPOSES; ENTERTAINMENT SERVICES, NAMELY, PROVIDING A WEB SITE FEATURING MUSICAL PERFORMANCES, MUSICAL VIDEOS, RELATED FILM CLIPS, PHOTOGRAPHS, AND OTHER MULTIMEDIA MATERIALS IN THE FIELDS OF RELATIONSHIPS, BUSINESS, HEALTH, BOOKS, MUSIC, AND POLITICS; ENTERTAINMENT SERVICES, NAMELY, PROVIDING AN ELECTRONIC NEWSLETTER IN THE FIELDS OF RELATIONSHIPS, BUSINESS, HEALTH, BOOKS, MUSIC, AND POLITICS; ENTERTAINMENT SERVICES, NAMELY, PROVIDING A WEB SITE FEATURING USER-GENERATED VIDEOS ON A VARIETY OF TOPICS AND SUBJECTS; ENTERTAINMENT SERVICES, NAMELY, PROVIDING A WEBSITE AT WHICH THE GENERAL PUBLIC CAN RECEIVE ADVICE AND COUNSEL IN THE FIELDS OF RELATIONSHIPS FOR ENTERTAINMENT PURPOSES ONLY; ENTERTAINMENT SERVICES, NAMELY, PROVIDING NON-DOWNLOADABLE PRERECORDED MUSIC AND INFORMATION IN THE FIELDS OF MUSIC, COMMENTARY, AND ARTICLES ABOUT MUSIC, ALL ONLINE VIA A GLOBAL COMPUTER NETWORK; PROVIDING INFORMATION, NEWS, AND COMMENTARY IN THE FIELD OF ENTERTAINMENT; SPECIAL EVENT PLANNING; ENTERTAINMENT SERVICES IN THE NATURE OF LIVE MUSICAL PERFORMANCES; ENTERTAINMENT SERVICES, NAMELY, PERSONAL APPEARANCES BY A NATIONALLY SYNDICATED RADIO PERSONALITY, BEST-SELLING AUTHOR, AND MOTIVATIONAL SPEAKER; ENTERTAINMENT SERVICES, NAMELY, PROVIDING A RADIO PROGRAM IN THE FIELDS OF RELATIONSHIPS, BUSINESS, HEALTH, BOOKS, MUSIC, AND POLITICS VIA A GLOBAL COMPUTER NETWORK; ENTERTAINMENT SERVICES IN THE NATURE OF AN ONGOING TELEVISION PROGRAM IN THE FIELD OF RELATIONSHIPS, BUSINESS, HEALTH, BOOKS, MUSIC, AND POLITICS VIA A GLOBAL COMPUTER NETWORK; ENTERTAINMENT SERVICES, NAMELY, PROVIDING ONLINE REVIEWS OF BOOKS, MUSIC, TV, FILM, MOVIES, SHOW TOPICS, SOCIAL ENTERTAINMENT, AND COMPUTER GAMES; ONLINE JOURNALS, NAMELY, BLOGS FEATURING DISCUSSIONS ABOUT BOOKS, MUSIC, SOCIAL ENTERTAINMENT TOPICS, RADIO SHOW TOPICS, FAN CLUBS, EVENTS, POEMS, AND INTERVIEWS; PRODUCTION OF RADIO OR TELEVISION PROGRAMS; PROVIDING A WEB SITE WHERE USERS CAN POST RATINGS, REVIEWS, AND RECOMMENDATIONS ON EVENTS AND ACTIVITIES IN THE FIELD OF ENTERTAINMENT AND EDUCATION; RADIO ENTERTAINMENT SERVICES, NAMELY, RADIO PROGRAMS FEATURING PERFORMANCES BY A NATIONALLY SYNDICATED RADIO PERSONALITY, BEST-SELLING AUTHOR, AND MOTIVATIONAL SPEAKER; TICKET RESERVATION AND BOOKING SERVICES FOR ENTERTAINMENT, SPORTING, AND CULTURAL EVENTS; ENTERTAINMENT SERVICES, NAMELY, CONDUCTING PARTIES FOR THE PURPOSE OF DATING AND SOCIAL INTRODUCTION FOR ADULTS (U.S. CLS. 100, 101 AND 107).

FIRST USE 9-25-2005; IN COMMERCE 9-25-2005.

**CLASS 42—SCIENTIFIC AND COMPUTER SERVICES**

FOR COMPUTER SERVICES IN THE NATURE OF CUSTOMIZED WEB PAGES FEATURING USER-DEFINED INFORMATION, PERSONAL PROFILES, AND MULTIMEDIA CONTENT; COMPUTER SERVICES, NAMELY, CREATING AN ONLINE COMMUNITY FOR REGISTERED USERS TO PARTICIPATE IN DISCUSSIONS, GET FEEDBACK FROM THEIR PEERS, AND ENGAGE IN SOCIAL NETWORKING; PROVIDING A WEB SITE FEATURING TEMPORARY USE OF NON-DOWNLOADABLE SOFTWARE ALLOWING WEB SITE USERS TO UPLOAD, POST, AND DISPLAY ONLINE VIDEOS FOR SHARING WITH OTHERS FOR ENTERTAINMENT AND INFORMATION PURPOSES; PROVIDING TEMPORARY USE OF NON-DOWNLOADABLE SOFTWARE APPLICATIONS FOR PHOTO SHARING, VIDEO SHARING, AND TRANSMISSION OF PHOTOGRAPHIC IMAGES; COMPUTER SERVICES, NAMELY, HOSTING ONLINE WEB FACILITIES FOR OTHERS

FOR ORGANIZING AND CONDUCTING ONLINE MEETINGS, GATHERINGS, AND INTERACTIVE DISCUSSIONS; APPLICATION SERVICE PROVIDER FEATURING SOFTWARE TO ENABLE UPLOADING, POSTING, SHOWING, DISPLAYING, TAGGING, BLOGGING, SHARING OR OTHERWISE PROVIDING ELECTRONIC MEDIA OR INFORMATION OVER THE INTERNET OR OTHER COMMUNICATIONS NETWORK; PROVIDING A WEB SITE OVER THE INTERNET OR ELECTRONIC COMMUNICATIONS NETWORKS THAT GIVES COMPUTER USERS THE ABILITY TO TAG VIDEO CLIPS; PROVIDING TEMPORARY USE OF NON-DOWNLOADABLE SOFTWARE APPLICATIONS FOR CREATING AND POSTING CLASSIFIED ADVERTISEMENTS (U.S. CLS. 100 AND 101).

FIRST USE 9-25-2005; IN COMMERCE 9-25-2005.

**CLASS 45—PERSONAL AND LEGAL SERVICES**

FOR PROVIDING A SOCIAL NETWORKING WEBSITE FOR ENTERTAINMENT PURPOSES; PROVIDING ONLINE COMPUTER DATABASES AND ON-LINE SEARCHABLE DATABASES IN THE FIELD OF SOCIAL NETWORKING (U.S. CLS. 100 AND 101).

FIRST USE 9-25-2005; IN COMMERCE 9-25-2005.  
CAROL SPILS, EXAMINING ATTORNEY

---

SN 77-818,189. DUTCH BLACKSMITH SHOP LTD., PILOT BUTTE SK, CANADA, FILED 9-2-2009.

**QUALITY FOR GENERATIONS**

THE MARK CONSISTS OF STANDARD CHARACTERS WITHOUT CLAIM TO ANY PARTICULAR FONT, STYLE, SIZE, OR COLOR.

OWNER OF CANADA REG. NO. TMA783,553, DATED 11-26-2010, EXPIRES 11-26-2025.

NO CLAIM IS MADE TO THE EXCLUSIVE RIGHT TO USE "QUALITY", APART FROM THE MARK AS SHOWN.

**CLASS 7—MACHINERY**

FOR AGRICULTURAL MACHINE PRODUCTS, NAMELY, BANDING AND SEEDING OPENERS, RIGID CROP LIFTERS, CAB FILTERS, CHAFF/STRAW SPREADERS, CATTLE OILERS, AND WINDMILLS (U.S. CLS. 13, 19, 21, 23, 31, 34 AND 35).

**CLASS 37—CONSTRUCTION AND REPAIR**

FOR REPAIR OF METAL PRODUCTS IN THE FIELDS OF AGRICULTURE AND INDUSTRY (U.S. CLS. 100, 103 AND 106).

**CLASS 40—MATERIAL TREATMENT**

FOR MANUFACTURING AND FABRICATION OF METAL PRODUCTS IN THE FIELDS OF AGRICULTURE AND INDUSTRY (U.S. CLS. 100, 103 AND 106).  
ZACHARY BELLO, EXAMINING ATTORNEY



SN 77-818,566. AAFM, LLC, AKA ACADEMY OF FINANCIAL MANAGEMENT, METAIRIE, LA. FILED 9-2-2009.

## IAFM International Academy of Financial Management

THE MARK CONSISTS OF STANDARD CHARACTERS WITHOUT CLAIM TO ANY PARTICULAR FONT, STYLE, SIZE, OR COLOR.

OWNER OF U.S. REG. NO. 3,714,562.

NO CLAIM IS MADE TO THE EXCLUSIVE RIGHT TO USE "INTERNATIONAL ACADEMY OF FINANCIAL MANAGEMENT", APART FROM THE MARK AS SHOWN.

### CLASS 35—ADVERTISING AND BUSINESS

FOR ADVERTISING AND BUSINESS SERVICES, NAMELY, PROVIDING AN ONLINE WEBSITES WHERE ADVERTISERS, MARKETERS, AND CONTENT PROVIDERS CAN INTERACT WITH USERS FOR ADVERTISING, BRANDING, AND PROMOTING KNOWLEDGE, PRODUCTS, AND SERVICES, AND TRADESHOWS, ON BEHALF OF THEMSELVES AND OTHERS, AND FOR EVALUATING AND RATING THE SAME, ALL THE FOREGOING RELEVANT TO HUMAN ACTIVITIES AFFECTING CLIMATE CHANGE AND RELATED FIELDS; ADVERTISING SERVICES, NAMELY, PROVIDING A WEBSITE FOR THE PROMOTION OF THE BOOKS OF OTHERS IN THE FIELD OF LAW, INCLUDING NEWS AND REVIEWS REGARDING SAME (U.S. CLS. 100, 101 AND 102).

FIRST USE 1-1-2000; IN COMMERCE 12-1-2004.

### CLASS 41—EDUCATION AND ENTERTAINMENT

FOR PROVIDING AN ACADEMIC HONOR SOCIETY IN WHICH STUDENTS ARE ADMITTED IN RECOGNITION OF ACADEMIC ACHIEVEMENT (U.S. CLS. 100, 101 AND 107).

FIRST USE 1-1-2000; IN COMMERCE 12-1-2004.

STEVEN PEREZ, EXAMINING ATTORNEY

SN 77-819,118. AUTOSALES, INCORPORATED, TALLMADGE, OH. FILED 9-3-2009.

## TRICK FLOW

THE MARK CONSISTS OF STANDARD CHARACTERS WITHOUT CLAIM TO ANY PARTICULAR FONT, STYLE, SIZE, OR COLOR.

OWNER OF U.S. REG. NOS. 1,887,752, 2,681,311 AND OTHERS.

### CLASS 4—LUBRICANTS AND FUELS

FOR (BASED ON INTENT TO USE) AUTOMOBILE LUBRICANTS, NAMELY, ASSEMBLY LUBE (BASED ON USE IN COMMERCE) AUTOMOBILE LUBRICANTS, NAMELY, ENGINE OIL SUPPLEMENTS (U.S. CLS. 1, 6 AND 15).

FIRST USE 2-16-2009; IN COMMERCE 2-16-2009.

### CLASS 7—MACHINERY

FOR (BASED ON USE IN COMMERCE) INTERNAL COMBUSTION VEHICLE ENGINE PARTS, NAMELY, IGNITION WIRES, GASKETS, ELECTRONIC FUEL INJECTION (EFI) SPACERS AND PHENOLIC SPACERS FOR USE WITH INTAKE MANIFOLDS, PISTONS, PULL-EYS, AIR CLEANERS, AIR INLET ELBOWS, INTAKE MANIFOLD PLENUMS, VALVE COVERS, VALVE SPRINGS, VALVE SEATS, VALVE GUIDES, GUIDE-PLATES, STUD GIRDLES, LIFTERS, FUEL INJECTORS, FUEL FILTERS AND ELEMENTS, FUEL RAILS, FUEL PUMPS, FUEL PRESSURE REGULATORS, TIMING CHAINS AND GEAR SETS, OIL FILLER TUBES, OIL OVERFLOW TANKS, COLD AIR INTAKE TUBES, BRACKETS, FILTERS AND FILTER ELEMENTS, THROTTLE BODY ADAPTORS, CYLINDER HEADS FOR ENGINES, INTAKE VALVES, EXHAUST VALVES, AUTOMOTIVE INTAKE MANIFOLDS, ROCKER ARMS, CAMSHAFTS, PUSH RODS, AND COOLANT AND TRANSMISSION FLUID HOSES AND COUPLINGS THEREFOR; NITROUS OXIDE INJECTORS AND INJECTOR PARTS FOR LAND AND WATER VEHICLE ENGINES, AND VEHICLE ENGINE FASTENERS, NAMELY, BOLTS, STUDS AND LOCK NUTS; FASTENERS FOR VEHICLE ENGINE COMPONENTS, NAMELY, AIR CLEANER STUDS, ENGINE MANIFOLD FASTENERS, AIR CONDITIONER (AC) ELEMENT BRACKETS, VALVE COVER STUDS, AND VALVE COVER SPACERS (BASED ON INTENT TO USE) INTERNAL COMBUSTION ENGINE PARTS, NAMELY, EXHAUST HEADERS AS PART OF A VEHICLE EXHAUST SYSTEM (U.S. CLS. 13, 19, 21, 23, 31, 34 AND 35).

FIRST USE 8-1-1986; IN COMMERCE 8-1-1986.

### CLASS 9—ELECTRICAL AND SCIENTIFIC APPARATUS

FOR (BASED ON USE IN COMMERCE) CAM DEGREE KITS FOR DIAGNOSING AND TUNING VEHICLE ENGINES, COMPRISING A CAM DEGREE WHEEL, CAM CHECKING FIXTURE, DIAL INDICATOR, PISTON STOP, VALVE SPRING CHECKING SPRING, INSTRUCTIONS, AND A CASE; (BASED ON INTENT TO USE) ELECTRONIC PROGRAMMING EQUIPMENT, NAMELY, POWERTRAIN CONTROL MODULE (PCM) FLASH TUNERS FOR USE IN REPLACING AND REPROGRAMMING ENGINE CONTROL MODULES (U.S. CLS. 21, 23, 26, 36 AND 38).

### CLASS 12—VEHICLES

FOR (BASED ON USE IN COMMERCE) LAND VEHICLE TRANSMISSION PARTS, NAMELY, TRANSMISSION PANS AND DIFFERENTIAL COVERS; (BASED ON INTENT-TO-USE) LAND VEHICLE TRANSMISSION PARTS, NAMELY, FLYWHEELS (U.S. CLS. 19, 21, 23, 31, 35 AND 44).

FIRST USE 10-31-2007; IN COMMERCE 10-31-2007.

JOHN GARTNER, EXAMINING ATTORNEY

SN 77-819,158. AUTOSALES, INCORPORATED, TALLMADGE, OH. FILED 9-3-2009.

OWNER OF U.S. REG. NOS. 1,887,752, 2,229,388 AND 2,681,311.

THE MARK CONSISTS OF THE WORDS "TRICK FLOW" IN SCRIPT.

**CLASS 4—LUBRICANTS AND FUELS**

FOR (BASED ON INTENT TO USE) AUTOMOBILE LUBRICANTS, NAMELY, ASSEMBLY LUBE (BASED ON USE IN COMMERCE) AUTOMOBILE LUBRICANTS, NAMELY, ENGINE OIL SUPPLEMENTS (U.S. CLS. 1, 6 AND 15).

FIRST USE 2-16-2009; IN COMMERCE 2-16-2009.

SN 77-831,654. DACHIS GROUP, AUSTIN, TX. FILED 9-22-2009.

**SOCIAL BUSINESS DESIGN**

THE MARK CONSISTS OF STANDARD CHARACTERS WITHOUT CLAIM TO ANY PARTICULAR FONT, STYLE, SIZE, OR COLOR.

NO CLAIM IS MADE TO THE EXCLUSIVE RIGHT TO USE "BUSINESS DESIGN", APART FROM THE MARK AS SHOWN.

**CLASS 7—MACHINERY**

FOR (BASED ON USE IN COMMERCE) INTERNAL COMBUSTION VEHICLE ENGINE PARTS, NAMELY, IGNITION WIRES, GASKETS, ELECTRONIC FUEL INJECTION (EFI) SPACERS AND PHENOLIC SPACERS FOR USE WITH INTAKE MANIFOLDS, PISTONS, PULL-YS, AIR CLEANERS, AIR INLET ELBOWS, INTAKE MANIFOLD PLENUMS, VALVE COVERS, VALVE SPRINGS, VALVE SEATS, VALVE GUIDES, GUIDE-PLATES, STUD GIRDLES, LIFTERS, FUEL INJECTORS, FUEL FILTERS AND ELEMENTS, FUEL RAILS, FUEL PUMPS, FUEL PRESSURE REGULATORS, TIMING CHAINS AND GEAR SETS, OIL FILLER TUBES, OIL OVERFLOW TANKS, COLD AIR INTAKE TUBES, BRACKETS, FILTERS AND FILTER ELEMENTS, THROTTLE BODY ADAPTORS, CYLINDER HEADS FOR ENGINES, INTAKE VALVES, EXHAUST VALVES, AUTOMOTIVE INTAKE MANIFOLDS, ROCKER ARMS, CAMSHAFTS, PUSH RODS, AND COOLANT AND TRANSMISSION FLUID HOSES AND COUPLINGS THEREFOR; NITROUS OXIDE INJECTORS AND INJECTOR PARTS FOR LAND AND WATER VEHICLE ENGINES, AND VEHICLE ENGINE FASTENERS, NAMELY, BOLTS, STUDS AND LOCK NUTS; FASTENERS FOR VEHICLE ENGINE COMPONENTS, NAMELY, AIR CLEANER STUDS, ENGINE MANIFOLD FASTENERS, AIR CONDITIONER (AC) ELEMENT BRACKETS, VALVE COVER STUDS, AND VALVE COVER SPACERS (BASED ON INTENT TO USE) INTERNAL COMBUSTION ENGINE PARTS, NAMELY, EXHAUST HEADERS AS PART OF A VEHICLE EXHAUST SYSTEM (U.S. CLS. 13, 19, 21, 23, 31, 34 AND 35).

FIRST USE 8-1-1986; IN COMMERCE 8-1-1986.

**CLASS 35—ADVERTISING AND BUSINESS**

FOR CONSULTATION SERVICES FOR DEVELOPING A METHODOLOGY, PROCESS AND SERVICE DELIVERY FRAMEWORK FOR THE DELIVERY OF BUSINESS TRANSFORMATION SERVICES, NAMELY, MANAGEMENT CONSULTING, CHANGE MANAGEMENT, BUSINESS PROCESS REENGINEERING, MARKETING COMMUNICATION SERVICES AND BUSINESS INTEGRATION SERVICES IN THE NATURE OF ORGANIZATIONAL DEVELOPMENT FOR BUSINESS AND COMMERCIAL GAIN FOR THE CREATION OF DYNAMIC AND SOCIALLY CALIBRATED SYSTEMS, PROCESS AND CULTURE (U.S. CLS. 100, 101 AND 102).

**CLASS 42—SCIENTIFIC AND COMPUTER SERVICES**

FOR TECHNICAL DESIGN AND DEVELOPMENT SERVICES; DEVELOPMENT OF SOFTWARE APPLICATIONS FOR THE CREATION AND EXECUTION OF DYNAMIC AND SOCIALLY CALIBRATED SYSTEMS, PROCESS AND CULTURE (U.S. CLS. 100 AND 101).

JACQUELINE A. LAVINE, EXAMINING ATTORNEY

**CLASS 9—ELECTRICAL AND SCIENTIFIC APPARATUS**

FOR (BASED ON USE IN COMMERCE) CAM DEGREE KITS FOR DIAGNOSING AND TUNING VEHICLE ENGINES, COMPRISING A CAM DEGREE WHEEL, CAM CHECKING FIXTURE, DIAL INDICATOR, PISTON STOP, VALVE SPRING CHECKING SPRING, INSTRUCTIONS, AND A CASE; (BASED ON INTENT-TO-USE) ELECTRONIC PROGRAMMING EQUIPMENT, NAMELY, POWERTRAIN CONTROL MODULE (PCM) FLASH TUNERS FOR USE IN REPLACING AND REPROGRAMMING ENGINE CONTROL MODULES (U.S. CLS. 21, 23, 26, 36 AND 38).

SN 77-835,616. GOOGLE INC., MOUNTAIN VIEW, CA. FILED 9-25-2009.

**GOOGLE LATITUDE**

THE MARK CONSISTS OF STANDARD CHARACTERS WITHOUT CLAIM TO ANY PARTICULAR FONT, STYLE, SIZE, OR COLOR.

SEC. 2(F) AS TO "LATITUDE".

THE 2(F) IN PART CLAIM IS RESTRICTED TO CLASS(ES) 9 AND 42

**CLASS 12—VEHICLES**

FOR (BASED ON USE IN COMMERCE) LAND VEHICLE TRANSMISSION PARTS, NAMELY, TRANSMISSION PANS AND DIFFERENTIAL COVERS; (BASED ON INTENT-TO-USE) LAND VEHICLE TRANSMISSION PARTS, NAMELY, FLYWHEELS (U.S. CLS. 19, 21, 23, 31, 35 AND 44).

FIRST USE 10-31-2007; IN COMMERCE 10-31-2007.  
JOHN GARTNER, EXAMINING ATTORNEY

**CLASS 9—ELECTRICAL AND SCIENTIFIC APPARATUS**

FOR DOWNLOADABLE SOFTWARE IN THE NATURE OF A MOBILE APPLICATION FOR DISPLAYING AND SHARING A USER'S LOCATION, AND FINDING AND LOCATING OTHER USERS (U.S. CLS. 21, 23, 26, 36 AND 38).

FIRST USE 2-4-2009; IN COMMERCE 2-4-2009.

**CLASS 42—SCIENTIFIC AND COMPUTER SERVICES**

FOR PROVIDING ON-LINE NON-DOWNLOADABLE SOFTWARE FOR DISPLAYING AND SHARING A USER'S LOCATION, AND FINDING AND LOCATING OTHER USERS (U.S. CLS. 100 AND 101).  
FIRST USE 2-4-2009; IN COMMERCE 2-4-2009.

**CLASS 45—PERSONAL AND LEGAL SERVICES**

FOR ON-LINE SOCIAL NETWORKING SERVICES (U.S. CLS. 100 AND 101).  
FIRST USE 2-4-2009; IN COMMERCE 2-4-2009.  
DAVID TOOLEY, EXAMINING ATTORNEY

SN 77-836,477. BURNDY TECHNOLOGY LLC, MANCHESTER, NH. FILED 9-28-2009.



THE MARK CONSISTS OF A STYLIZED LETTER "B" CREATED BY TWO CENTRAL PARALLEL LINES, THE END OF THE UPPER LINE LOOPING UP AND OVER ITSELF, AND THE END OF THE LOWER LINE LOOPING BELOW AND UNDER ITSELF.

**CLASS 4—LUBRICANTS AND FUELS**

FOR METAL SEALING AND OXIDE INHIBITING COMPOUND FOR USE AS AN ANTI-SEIZING THREAD LUBRICANT IN ELECTRICAL CONNECTORS (U.S. CLS. 1, 6 AND 15).  
FIRST USE 12-31-1975; IN COMMERCE 12-31-1975.

**CLASS 7—MACHINERY**

FOR HAND HELD BATTERY OPERATED CRIMPING TOOLS AND DIES THEREFOR (U.S. CLS. 13, 19, 21, 23, 31, 34 AND 35).  
FIRST USE 12-31-1994; IN COMMERCE 12-31-1994.

**CLASS 8—HAND TOOLS**

FOR HAND TOOLS AND HAND INSTRUMENTS, NAMELY, HAND CRIMPING TOOLS FOR INSTALLING TERMINALS AND CRIMPING ELECTRICAL OR ELECTRONIC WIRES AND CABLES; WIRE AND CABLE CUTTERS; ACCESSORIES IN THE NATURE OF HAMMERS; RATCHET WRENCHES; PLIERS AND DIES (U.S. CLS. 23, 28 AND 44).  
FIRST USE 1-6-1966; IN COMMERCE 1-6-1966.

**CLASS 9—ELECTRICAL AND SCIENTIFIC APPARATUS**

FOR ELECTRICAL AND ELECTRONIC CONNECTORS AND PARTS THEREOF (U.S. CLS. 21, 23, 26, 36 AND 38).  
FIRST USE 1-6-1966; IN COMMERCE 1-6-1966.

**CLASS 22—CORDAGE AND FIBERS**

FOR CABLE TIES (U.S. CLS. 1, 2, 7, 19, 22, 42 AND 50).  
FIRST USE 12-31-1984; IN COMMERCE 12-31-1984.  
JOHN WILKE, EXAMINING ATTORNEY

SN 77-837,497. ANTHONY L. BIRCH, BETHESDA, MD. FILED 9-29-2009.

**GREEN FLOW**

THE MARK CONSISTS OF STANDARD CHARACTERS WITHOUT CLAIM TO ANY PARTICULAR FONT, STYLE, SIZE, OR COLOR.

NO CLAIM IS MADE TO THE EXCLUSIVE RIGHT TO USE "GREEN", APART FROM THE MARK AS SHOWN.

**CLASS 35—ADVERTISING AND BUSINESS**

FOR RETAIL STORE SERVICES FEATURING CONVENIENCE STORE ITEMS (U.S. CLS. 100, 101 AND 102).

**CLASS 37—CONSTRUCTION AND REPAIR**

FOR VEHICLE SERVICE STATIONS FEATURING ALTERNATIVE FUELS, NAMELY, NATURAL GAS (U.S. CLS. 100, 103 AND 106).

**CLASS 39—TRANSPORTATION AND STORAGE**

FOR DISTRIBUTION OF ELECTRICAL ENERGY (U.S. CLS. 100 AND 105).  
TINA BROWN, EXAMINING ATTORNEY

SN 77-838,940. J&L MARKETING, INC., LOUISVILLE, KY. FILED 10-1-2009.

**BPREPARED PROFIT ATLAS**

THE MARK CONSISTS OF STANDARD CHARACTERS WITHOUT CLAIM TO ANY PARTICULAR FONT, STYLE, SIZE, OR COLOR.

NO CLAIM IS MADE TO THE EXCLUSIVE RIGHT TO USE "PROFIT", APART FROM THE MARK AS SHOWN.

**CLASS 9—ELECTRICAL AND SCIENTIFIC APPARATUS**

FOR DOWNLOADABLE ELECTRONIC PUBLICATIONS, NAMELY, BEST PRACTICES MANUALS FOR MARKETING EVENTS (U.S. CLS. 21, 23, 26, 36 AND 38).

**CLASS 16—PAPER GOODS AND PRINTED MATTER**

FOR PRINTED PUBLICATIONS, NAMELY, BEST PRACTICES MANUALS FOR MARKETING EVENTS (U.S. CLS. 2, 5, 22, 23, 29, 37, 38 AND 50).  
NAPOLEON SHARMA, EXAMINING ATTORNEY

SN 77-838,992. ACCESS TO MONEY, INC., CHERRY HILL, NJ. FILED 10-1-2009.

# ACCESS TO MONEY

THE MARK CONSISTS OF STANDARD CHARACTERS WITHOUT CLAIM TO ANY PARTICULAR FONT, STYLE, SIZE, OR COLOR.

OWNER OF U.S. REG. NOS. 2,530,861 AND 3,425,289.

## CLASS 35—ADVERTISING AND BUSINESS

FOR DATA PROCESSING SERVICES, NAMELY, PROCESSING TRANSACTIONS RELATED TO AUTOMATED TRANSACTION MACHINES AND AUTOMATED TELLER MACHINES; ADVERTISING FOR OTHERS VIA COMMUNICATIONS ON TRANSACTION RECEIPTS, AUTOMATED TRANSACTION MACHINES AND AUTOMATED TELLER MACHINES; RETAIL SALE AND WHOLESALE DISTRIBUTORSHIP SERVICES IN THE FIELD OF EQUIPMENT USED BY FINANCIAL INSTITUTIONS, NAMELY, ALARM SYSTEMS, AUTOMATED TRANSACTION MACHINES, AUTOMATED TELLER MACHINES, BULLET PROOF GLASS, CASH RECYCLERS, PNEUMATIC TELLER DEVICES, SAFE DEPOSIT BOXES, UNDER COUNTER STEEL, VAULTS, AND VIDEO CAMERAS (U.S. CLS. 100, 101 AND 102).

FIRST USE 2-28-1997; IN COMMERCE 2-28-1997.

## CLASS 36—INSURANCE AND FINANCIAL

FOR ELECTRONIC FUNDS TRANSFER SERVICES; LEASING OF AUTOMATED TRANSACTION MACHINES AND AUTOMATED TELLER MACHINES; ELECTRONIC BANKING SERVICES; AUTOMATED TRANSACTION MACHINE SERVICES; AUTOMATED TELLER MACHINE SERVICES; FINANCIAL INFORMATION SERVICES PROVIDED BY ELECTRONIC MEANS; OPERATION OF AUTOMATED TRANSACTION MACHINES AND AUTOMATED TELLER MACHINES FOR OTHERS (U.S. CLS. 100, 101 AND 102).

FIRST USE 2-28-1997; IN COMMERCE 2-28-1997.

## CLASS 37—CONSTRUCTION AND REPAIR

FOR MAINTENANCE OF EQUIPMENT PRIMARILY USED BY FINANCIAL INSTITUTIONS, NAMELY, ALARM SYSTEMS, AUTOMATED TRANSACTION MACHINES, AUTOMATED TELLER MACHINES, BULLET PROOF GLASS, CASH RECYCLERS, PNEUMATIC TELLER DEVICES, SAFE DEPOSIT BOXES, UNDER COUNTER STEEL, VAULTS, AND VIDEO CAMERAS (U.S. CLS. 100, 103 AND 106).

FIRST USE 2-28-1997; IN COMMERCE 2-28-1997.

LINDA ESTRADA, EXAMINING ATTORNEY

SN 77-839,506. COMSOL AB, STOCKHOLM, SWEDEN, FILED 10-1-2009.

# LIVELINK

THE MARK CONSISTS OF STANDARD CHARACTERS WITHOUT CLAIM TO ANY PARTICULAR FONT, STYLE, SIZE, OR COLOR.

## CLASS 9—ELECTRICAL AND SCIENTIFIC APPARATUS

FOR COMPUTER SOFTWARE, NAMELY, SOFTWARE FOR USE IN PROVIDING A GRAPHICAL USER INTERFACE AND CONNECTION BETWEEN FINITE ELEMENT ANALYSIS (FEA) BASED MATHEMATICAL SOFTWARE AND CAD SOFTWARE, AND FEA BASED MATHEMATICAL SOFTWARE AND GENERAL MATHEMATICAL TECHNICAL COMPUTING SOFTWARE PACKAGES (U.S. CLS. 21, 23, 26, 36 AND 38).

## CLASS 42—SCIENTIFIC AND COMPUTER SERVICES

FOR PROVIDING TEMPORARY USE OF NON-DOWNLOADABLE SOFTWARE FOR USE IN PROVIDING A GRAPHICAL USER INTERFACE AND CONNECTION BETWEEN FINITE ELEMENT ANALYSIS (FEA) BASED MATHEMATICAL SOFTWARE AND CAD SOFTWARE, AND FEA BASED MATHEMATICAL SOFTWARE AND GENERAL MATHEMATICAL TECHNICAL COMPUTING SOFTWARE PACKAGES; RENTAL OF COMPUTER SOFTWARE FOR USE IN PROVIDING A GRAPHICAL USER INTERFACE AND CONNECTION BETWEEN FINITE ELEMENT ANALYSIS (FEA) BASED MATHEMATICAL SOFTWARE AND CAD SOFTWARE, AND FEA BASED MATHEMATICAL SOFTWARE AND GENERAL MATHEMATICAL TECHNICAL COMPUTING SOFTWARE PACKAGES; PROVIDING MAINTENANCE AND REPAIR TO SOFTWARE USED TO PROVIDE A GRAPHICAL USER INTERFACE AND CONNECTION BETWEEN FINITE ELEMENT ANALYSIS (FEA) BASED MATHEMATICAL SOFTWARE AND CAD SOFTWARE, AND FEA BASED MATHEMATICAL SOFTWARE AND GENERAL MATHEMATICAL TECHNICAL COMPUTING SOFTWARE PACKAGES; PROVIDING UPDATES TO SOFTWARE USED TO PROVIDE A GRAPHICAL USER INTERFACE AND CONNECTION BETWEEN FINITE ELEMENT ANALYSIS (FEA) BASED MATHEMATICAL SOFTWARE AND CAD SOFTWARE, AND FEA BASED MATHEMATICAL SOFTWARE AND GENERAL MATHEMATICAL TECHNICAL COMPUTING SOFTWARE PACKAGES (U.S. CLS. 100 AND 101).

## CLASS 45—PERSONAL AND LEGAL SERVICES

FOR LICENSING OF COMPUTER SOFTWARE FOR USE IN PROVIDING A GRAPHICAL USER INTERFACE AND CONNECTION BETWEEN FINITE ELEMENT ANALYSIS (FEA) BASED MATHEMATICAL SOFTWARE AND CAD SOFTWARE, AND FEA BASED MATHEMATICAL SOFTWARE AND GENERAL MATHEMATICAL TECHNICAL COMPUTING SOFTWARE PACKAGES (U.S. CLS. 100 AND 101).

JOHN DWYER, EXAMINING ATTORNEY

SN 77-840,613. RFI ENTERPRISES, INC., SAN JOSE, CA. FILED 10-2-2009.

## PERMISSION GRANTED

THE MARK CONSISTS OF STANDARD CHARACTERS WITHOUT CLAIM TO ANY PARTICULAR FONT, STYLE, SIZE, OR COLOR.

**CLASS 9—ELECTRICAL AND SCIENTIFIC APPARATUS**

FOR SECURITY ACCESS CONTROL AND ALARM MONITORING SYSTEM COMPRISED OF CONTROLLERS, MICROPROCESSORS, MOTHERBOARDS, CODED CARDS, TAGS AND BADGES AND READERS, MEMORY MODULES, ASSOCIATED COMPUTER SOFTWARE FOR USE IN CONFIGURING AND MANAGING CARD ACCESS AND FOR PROVIDING A USER INTERFACE, ALL SOLD AS A UNIT (U.S. CLS. 21, 23, 26, 36 AND 38).

FIRST USE 8-24-2009; IN COMMERCE 8-24-2009.

**CLASS 37—CONSTRUCTION AND REPAIR**

FOR INSTALLATION AND MAINTENANCE OF SURVEILLANCE AND SECURITY ACCESS CONTROL SYSTEMS (U.S. CLS. 100, 103 AND 106).

FIRST USE 8-24-2009; IN COMMERCE 8-24-2009.  
REGINA DRUMMOND, EXAMINING ATTORNEY

SN 77-843,384. LG ELECTRONICS INC., SEOUL, REPUBLIC OF KOREA, FILED 10-7-2009.

# Swing

THE MARK CONSISTS OF STANDARD CHARACTERS WITHOUT CLAIM TO ANY PARTICULAR FONT, STYLE, SIZE, OR COLOR.

**CLASS 7—MACHINERY**

FOR CLOTHES WASHING MACHINES (U.S. CLS. 13, 19, 21, 23, 31, 34 AND 35).

**CLASS 11—ENVIRONMENTAL CONTROL APPARATUS**

FOR CLOTHES DRYERS (U.S. CLS. 13, 21, 23, 31 AND 34).

ADA HAN, EXAMINING ATTORNEY

SN 77-844,980. DEFENSE ELECTRONICS CORPORATION, ST. PETERSBURG, FL. FILED 10-9-2009.



NO CLAIM IS MADE TO THE EXCLUSIVE RIGHT TO USE "DEFENSE ELECTRONICS CORPORATION", APART FROM THE MARK AS SHOWN.

THE MARK CONSISTS OF THE STYLIZED LETTERS "DEC" WITH A SINGLE STAR LOCATED TO THE LEFT OF THE "D" AND A SINGLE STAR LOCATED TO THE RIGHT OF THE "C" WITH ALL CONTAINED WITHIN A RECTANGLE; BELOW "DEC" IS THE STYLIZED WORDING "DEFENSE ELECTRONICS CORPORATION".

**CLASS 9—ELECTRICAL AND SCIENTIFIC APPARATUS**

FOR ELECTRONIC COMPONENTS, NAMELY, ELECTRONIC CONTROLS FOR USE WITH MILITARY, INDUSTRIAL AND COMMERCIAL ELECTRONIC AND ELECTRICAL EQUIPMENT; POWER ELECTRONICS, NAMELY, POWER SUPPLIES FOR USE WITH MILITARY, INDUSTRIAL AND COMMERCIAL ELECTRONIC AND ELECTRICAL EQUIPMENT; ENERGY HYBRID AND SCAVENGING DEVICES FOR COLLECTING EXCESS AND UNUSED ENERGY FROM MILITARY, INDUSTRIAL AND COMMERCIAL ELECTRONIC AND ELECTRICAL EQUIPMENT, NAMELY, THERMOELECTRIC CONVERTERS, ELECTRONIC AND ELECTRICAL APPARATUS FOR USE IN COLLECTING ENERGY FROM WIND, VIBRATION, THERMAL ENERGY, PHOTO-ELECTRIC ENERGY SOURCES AND KINETIC ENERGY SOURCES, MICRO-ELECTRO MECHANICAL APPARATUS AND CAPACITORS, SUPER CAPACITORS AND BATTERIES FOR USE IN COLLECTING AND STORING ENERGY, ELECTROMAGNETIC DEVICES COMPRISED OF OSCILLATING MAGNETS, PHOTOVOLTAIC SOLAR MODULES, SOLAR CELLS; INTELLIGENT POWER MANAGEMENT DEVICES, NAMELY, POWER FACTOR REGULATORS AND POWER VOLTAGE REGULATORS FOR USE WITH MILITARY, INDUSTRIAL AND COMMERCIAL ELECTRONIC AND ELECTRICAL EQUIPMENT; INTEGRATED CIRCUIT CARDS AND NON-INTEGRATED CIRCUIT CARDS, NAMELY, BLANK INTEGRATED CIRCUIT CARDS AND INTEGRATED CIRCUIT BOARDS AND NON-INTEGRATED CIRCUIT BOARD ASSEMBLIES, NAMELY, BLANK CIRCUIT BOARDS; ELECTRIC CABLES AND CABLE HARNESES FOR CONNECTING MILITARY, INDUSTRIAL AND COMMERCIAL ELECTRONIC AND ELECTRICAL EQUIPMENT; ENCAPSULATED AND EMBEDDED DEVICES, NAMELY, CIRCUIT BOARDS AND DISCRETE COMPONENTS, NAMELY, ELECTRICAL COMPONENTS IN THE NATURE OF PROTECTION RELAYS FOR PROTECTING MILITARY, INDUSTRIAL AND COMMERCIAL ELECTRONIC AND ELECTRICAL EQUIPMENT; APPARATUS FOR TRANSMISSION OF COMMUNICATION; CHARGING APPLIANCES FOR RECHARGEABLE EQUIPMENT, NAMELY, NITROGEN CHARGING SYSTEMS FOR MILITARY, INDUSTRIAL AND COMMERCIAL USE; ELECTRONIC COMMUNICATION DEVICES, NAMELY, TELEMETRY DATA SENSOR COMMUNICATIONS LINKS COMPRISED OF ELECTRONIC TRANSMITTERS, ELECTRONIC RECEIVERS, AND MICROPROCESSORS AND REMOTE MONITORING SUBSYSTEMS COMPRISED OF COMPUTER HARDWARE AND OPERATING SOFTWARE, CAMERAS FOR MONITORING, RADIO RECEIVERS, AUDIOVISUAL RECEIVERS, AND ELECTRONIC TRANSMITTERS FOR TRANSMITTING AUDIO, VIDEO AND TEXTUAL INFORMATION; SATELLITE COMMUNICATION EQUIPMENT, NAMELY, ANTENNAS; MICROWAVE SENSING EQUIPMENT, NAMELY, ELECTRONIC SENSORS FOR DETECTING MICROWAVES; WIRELESS COMMUNICATION EQUIPMENT, NAMELY, TRANSMITTERS AND RECEIVERS FOR WIRELESS NETWORKS; SENSING COMPUTER HARDWARE, NAMELY, ELECTRONIC TEST AND ANALYSIS EQUIPMENT AND DATA ACQUISITION DEVICES FOR POWER CONTROL AND MONITORING DEVICES; ELECTRONIC MONITORS, NAMELY, CAMERA AIDED MONITORS FOR SURVEILLANCE AND MONITORING; NIGHT VISION GOGGLES; SECURITY THREAT WARNING MONITORS, NAMELY, LCD MONITORS FOR SECURITY PURPOSES; SUBMINIATURE ELECTRONIC SENSORS FOR SENSING VISUAL OBJECTS AND ACOUSTIC INFORMATION; ELECTRONIC DATA LOGGERS FOR CAPTURING INFORMATION FROM MILITARY, INDUSTRIAL AND COMMERCIAL DATA ACQUISITION SENSORS; ELECTRIC AND ELECTRONIC TELEMETRY SENSORS, VIDEO SENSORS AND ACOUSTICAL SENSORS FOR USE IN SENSING THE PRESENCE OF INDIVIDUALS OR OBJECTS FOR SECURITY PURPOSES; ELECTRONIC SENSORS, NAMELY, NETWORKED SENSORS FOR USE IN SURVEILLANCE AND MONITORING; ELECTRONIC UNATTENDED GROUND SENSORS FOR USE IN SURVEILLANCE AND MONITORING (U.S. CLS. 21, 23, 26, 36 AND 38).

**CLASS 40—MATERIAL TREATMENT**

FOR PROTOTYPE FABRICATION, FABRICATION AND ASSEMBLY OF MECHANICAL, ELECTRICAL, AND ELECTROMECHANICAL DEVICES FOR OTHERS (U.S. CLS. 100, 103 AND 106).

**CLASS 42—SCIENTIFIC AND COMPUTER SERVICES**

FOR TESTING OF MECHANICAL, ELECTRICAL AND ELECTROMECHANICAL DEVICES FOR OTHERS; ENGINEERING RESEARCH AND DEVELOPMENT OF MECHANICAL, ELECTRICAL, AND ELECTROMECHANICAL DEVICES FOR OTHERS; SOFTWARE DEVELOPMENT FOR DECISION SUPPORT APPLICATIONS SENSORS, MONITORING AND CONTROL SYSTEMS FOR COMMAND, CONTROL, COMMUNICATIONS, COMPUTER OPERATING SOFTWARE AND SOFTWARE FOR GENERATING INFORMATION DISPLAYS, ALL FOR USE IN MILITARY SURVEILLANCE, SOFTWARE DEVELOPMENT FOR REAL-TIME EMBEDDED SYSTEMS FOR USE IN SATELLITE COMMUNICATIONS EQUIPMENT, ANTENNA BEAM STEERING CONTROL, AND FOR UNATTENDED GROUND SENSOR SYSTEMS USED FOR SURVEILLANCE; ONLINE SYSTEM MANAGEMENT SERVICES, NAMELY, WIRELESS MONITORING AND REMOTE CONTROL OF NETWORK DEVICES; SOFTWARE DEVELOPMENT FOR DIGITAL SIGNAL PROCESSING SYSTEMS, INTELLIGENT POWER MANAGEMENT ALGORITHMS, IMAGE COMPRESSION AND ENCRYPTION ALGORITHMS, AND WEB ENABLING SOFTWARE FOR USE IN ACCESSING THE INTERNET; SOFTWARE DEVELOPMENT FOR HUMAN COMPUTER AND GRAPHICAL USER INTERFACES (HCI/GUI), OPERATING SYSTEMS SOFTWARE DEVELOPMENT; SOFTWARE DEVELOPMENT FOR INTEGRATION OF LINE OF SIGHT TERRESTRIAL AND SATELLITE COMMUNICATIONS LINKS, COMPUTER HARDWARE AND SOFTWARE; SOFTWARE DEVELOPMENT FOR EMBEDDED WIRELESS NETWORKING; PROTOTYPE DESIGN OF MECHANICAL, ELECTRICAL AND ELECTROMECHANICAL DEVICES FOR OTHERS (U.S. CLS. 100 AND 101).

MARY CRAWFORD, EXAMINING ATTORNEY

SN 77-844,989. JEJU SPECIAL SELF-GOVERNING PROVINCE, JEJU-SI, REPUBLIC OF KOREA, FILED 10-9-2009.



PRIORITY CLAIMED UNDER SEC. 44(D) ON REPUBLIC OF KOREA APPLICATION NO. 2009-0037068, FILED 8-3-2009, REG. NO. 0843032, DATED 11-17-2010, EXPIRES 11-17-2020.

NO CLAIM IS MADE TO THE EXCLUSIVE RIGHT TO USE "JEJU OFFICIAL CERTIFICATION WATER" AND "JEJU WATER", APART FROM THE MARK AS SHOWN.

THE COLOR(S) BLUE, GRAY, GREEN AND LIGHT BLUE IS/ARE CLAIMED AS A FEATURE OF THE MARK.

THE MARK CONSISTS OF THE SEMI-CIRCULAR GRAY WORDING "JEJU OFFICIAL CERTIFICATION WATER" ON THE TOP HALF BETWEEN TWO BLUE CONCENTRIC CIRCLES AND THE BLUE WORDING "JEJU WATER" ON THE BOTTOM BETWEEN TWO BLUE CONCENTRIC CIRCLES. INSIDE THE BLUE CONCENTRIC CIRCLES IS A STYLIZED REPRESENTATION OF A FACE COMPRISED OF A GREEN AND GRAY HAT, BLUE EYES AND NOSE AND A LIGHT BLUE MOUTH.

**CLASS 32—LIGHT BEVERAGES**

FOR BEER; MINERAL WATER; DRINKING WATER; AERATED WATER; NON-AERATED WATER; JUICE, NAMELY, VEGETABLE JUICE AND FRUIT JUICE; NON-ALCOHOLIC BEVERAGES, NAMELY, FRUIT-BASED BEVERAGES AND CARBONATED BEVERAGES; SOFT DRINKS; SODA WATER; SYRUPS FOR MAKING BEVERAGES (U.S. CLS. 45, 46 AND 48).

**CLASS 33—WINES AND SPIRITS**

FOR LIQUEURS; VODKA; BRANDY; WINE; ALCOHOLIC BEVERAGES CONTAINING FRUIT; WHISKEY; ALCOHOLIC COCKTAIL MIXES AND PREPARED WINE COCKTAILS; COFFEE-BASED LIQUEURS; KAOLIANG LIQUOR; KOREAN "SOJU" LIQUOR DISTILLED MAINLY FROM GRAINS; SAKE (U.S. CLS. 47 AND 49).  
ALLISON HOLTZ, EXAMINING ATTORNEY

SN 77-846,643. PBM PRODUCTS, LLC, GORDONSVILLE, VA. FILED 10-12-2009.

**ADVANCED NUTRITION,  
SENSIBLE PRICES**

THE MARK CONSISTS OF STANDARD CHARACTERS WITHOUT CLAIM TO ANY PARTICULAR FONT, STYLE, SIZE, OR COLOR.

**CLASS 5—PHARMACEUTICALS**

FOR INFANT FORMULA; PEDIATRIC NUTRITIONAL DRINKS FOR CHILDREN; NUTRITIONAL DRINKS FOR DIABETICS; NUTRITIONAL DRINKS, NAMELY, MEAL REPLACEMENT DRINKS AND NUTRITIONAL SUPPLEMENTS IN BEVERAGE FORM; ANTI-DIABETIC PREPARATIONS, INCLUDING GEL FOR ASSISTING DIABETICS IN REGULATING THEIR BLOOD SUGAR (U.S. CLS. 6, 18, 44, 46, 51 AND 52).

**CLASS 30—STAPLE FOODS**

FOR CEREAL-BASED SNACK FOODS (U.S. CL. 46).  
NICHOLAS COLEMAN, EXAMINING ATTORNEY

SN 77-847,343. GREENE, RHAMELLE M., BROOKLYN, NY. FILED 10-13-2009.

**MOVE THE CROWD**

THE MARK CONSISTS OF STANDARD CHARACTERS WITHOUT CLAIM TO ANY PARTICULAR FONT, STYLE, SIZE, OR COLOR.

**CLASS 35—ADVERTISING AND BUSINESS**

FOR ONLINE RETAIL STORE SERVICES FEATURING EDUCATIONAL MATERIALS, APPAREL, AND A WIDE VARIETY OF CONSUMER GOODS OF OTHERS; RETAIL STORE SERVICES FEATURING EDUCATIONAL MATERIALS, APPAREL, AND A WIDE VARIETY OF CONSUMER GOODS OF OTHERS (U.S. CLS. 100, 101 AND 102).

**CLASS 38—COMMUNICATION**

FOR ONLINE VIDEO STREAMING AND PODCASTING SERVICES FEATURING LIVE AND PRE-RECORDED CULTURAL PROGRAMS, TELEVISION SHOWS, FILMS AND RADIO PROGRAMS (U.S. CLS. 100, 101 AND 104).

**CLASS 41—EDUCATION AND ENTERTAINMENT**

FOR ENTERTAINMENT SERVICES, NAMELY, LIVE STAGE AND MUSICAL PERFORMANCES, ONGOING RADIO SHOWS AND ONGOING TELEVISION SHOWS, ALL IN THE FIELDS OF ENTREPRENEURSHIP AND PERSONAL AND PROFESSIONAL DEVELOPMENT (U.S. CLS. 100, 101 AND 107).

MARTHA FROMM, EXAMINING ATTORNEY

**CLASS 7—MACHINERY**

FOR (BASED ON USE IN COMMERCE) INTERNAL COMBUSTION VEHICLE ENGINE PARTS, NAMELY, IGNITION WIRES, GASKETS, ELECTRONIC FUEL INJECTION (EFI) SPACERS AND PHENOLIC SPACERS FOR USE WITH INTAKE MANIFOLDS, PISTONS, PULLEYS, AIR CLEANERS, AIR INLET ELBOWS, INTAKE MANIFOLD PLENUMS, VALVE COVERS, VALVE SPRINGS, VALVE SEATS, VALVE GUIDES, GUIDE-PLATES, STUD GIRDLES, LIFTERS, FUEL INJECTORS, FUEL FILTERS AND ELEMENTS, FUEL RAILS, FUEL PUMPS, FUEL PRESSURE REGULATORS, TIMING CHAINS AND GEAR SETS, OIL FILLER TUBES, OIL OVERFLOW TANKS, COLD AIR INTAKE TUBES, BRACKETS, FILTERS AND FILTER ELEMENTS, THROTTLE BODY ADAPTORS, CYLINDER HEADS FOR ENGINES, INTAKE VALVES, EXHAUST VALVES, AUTOMOTIVE INTAKE MANIFOLDS, ROCKER ARMS, CAMSHAFTS, PUSH RODS, AND COOLANT AND TRANSMISSION FLUID HOSES AND COUPLINGS THEREFOR; NITROUS OXIDE INJECTORS AND INJECTOR PARTS FOR LAND AND WATER VEHICLE ENGINES, AND VEHICLE ENGINE FASTENERS, NAMELY, BOLTS, STUDS AND LOCK NUTS; (BASED ON INTENT TO USE) HEADERS AS PART OF A VEHICLE EXHAUST SYSTEM (U.S. CLS. 13, 19, 21, 23, 31, 34 AND 35).

FIRST USE 11-2-2004; IN COMMERCE 11-2-2004.

**CLASS 9—ELECTRICAL AND SCIENTIFIC APPARATUS**

FOR (BASED ON USE IN COMMERCE) CAM DEGREE KITS FOR DIAGNOSING AND TUNING VEHICLE ENGINES, COMPRISING A CAM DEGREE WHEEL, CAM CHECKING FIXTURE, DIAL INDICATOR, PISTON STOP, VALVE SPRING CHECKING SPRING, INSTRUCTIONS, AND A CASE (BASED ON INTENT TO USE) ELECTRONIC PROGRAMMING EQUIPMENT, NAMELY, POWERTRAIN CONTROL MODULE (PCM) FLASH TUNERS FOR USE IN REPLACING AND REPROGRAMMING ENGINE CONTROL MODULES (U.S. CLS. 21, 23, 26, 36 AND 38).

**CLASS 12—VEHICLES**

FOR (BASED ON USE IN COMMERCE) LAND VEHICLE TRANSMISSION PARTS, NAMELY, TRANSMISSION PANS AND DIFFERENTIAL COVERS (BASED ON INTENT-TO-USE) LAND VEHICLE TRANSMISSION PARTS, NAMELY, FLYWHEELS (U.S. CLS. 19, 21, 23, 31, 35 AND 44).

FIRST USE 10-31-2007; IN COMMERCE 10-31-2007.

JOHN GARTNER, EXAMINING ATTORNEY

SN 77-848,492. AUTOSALES, INCORPORATED, TALLMADGE, OH. FILED 10-14-2009.

SN 77-848,509. NATIONAL URBAN LEAGUE, INC., NEW YORK, NY. FILED 10-14-2009.

**ULTIMATE BOLT-ON PERFORMANCE!**

**NATIONAL URBAN LEAGUE YOUNG PROFESSIONALS**

THE MARK CONSISTS OF STANDARD CHARACTERS WITHOUT CLAIM TO ANY PARTICULAR FONT, STYLE, SIZE, OR COLOR.

NO CLAIM IS MADE TO THE EXCLUSIVE RIGHT TO USE "BOLT-ON", APART FROM THE MARK AS SHOWN.

THE MARK CONSISTS OF STANDARD CHARACTERS WITHOUT CLAIM TO ANY PARTICULAR FONT, STYLE, SIZE, OR COLOR.

OWNER OF U.S. REG. NOS. 1,742,003, 2,023,561 AND OTHERS.

NO CLAIM IS MADE TO THE EXCLUSIVE RIGHT TO USE "YOUNG PROFESSIONALS", APART FROM THE MARK AS SHOWN.

SEC. 2(F) AS TO "NATIONAL URBAN LEAGUE".

**CLASS 4—LUBRICANTS AND FUELS**

FOR (BASED ON INTENT TO USE) AUTOMOBILE LUBRICANTS, NAMELY, ASSEMBLY LUBE AND ENGINE OIL SUPPLEMENTS (U.S. CLS. 1, 6 AND 15).

**CLASS 35—ADVERTISING AND BUSINESS**

FOR EDUCATION LEADERSHIP DEVELOPMENT IN SUPPORT OF AFRICAN-AMERICANS AND OTHERS (U.S. CLS. 100, 101 AND 102).

**CLASS 41—EDUCATION AND ENTERTAINMENT**

FOR EDUCATION SERVICES, NAMELY, PROVIDING FORUMS, CONFERENCES, CLASSES, SEMINARS, PANELS AND WORKSHOPS IN THE FIELD OF PROFESSIONAL DEVELOPMENT IN SUPPORT OF AFRICAN-AMERICANS AND OTHER PERSONS (U.S. CLS. 100, 101 AND 107).

**CLASS 45—PERSONAL AND LEGAL SERVICES**

FOR PROVIDING INFORMATION IN THE FIELD OF PERSONAL DEVELOPMENT, NAMELY, SELF-IMPROVEMENT, SELF-FULFILLMENT, AND INTERPERSONAL COMMUNICATION IN SUPPORT OF AFRICAN-AMERICANS AND OTHERS (U.S. CLS. 100 AND 101).  
ANNE E. GUSTASON, EXAMINING ATTORNEY

SN 77-849,676. M. KATAYAMA, TOKYO, JAPAN, FILED 10-15-2009.

**WONDERWALL**

THE MARK CONSISTS OF STANDARD CHARACTERS WITHOUT CLAIM TO ANY PARTICULAR FONT, STYLE, SIZE, OR COLOR.

**CLASS 16—PAPER GOODS AND PRINTED MATTER**

FOR PAPER, CARDBOARD AND GOODS MADE FROM PAPER AND CARDBOARD, NAMELY, BINDERS FOR OFFICE USE; PRINTED MATTER, NAMELY, NEWSPAPER, PHOTOGRAPHS, MAGAZINES, BOOKS, PRINTED PERIODICALS, NEWSLETTERS AND BROCHURES IN THE FIELD OF INTERIOR DECORATING AND ARCHITECTURE DESIGN; BOOKBINDING MATERIAL; PHOTOGRAPHS; STATIONERY; ADHESIVES FOR STATIONERY OR HOUSEHOLD PURPOSES; ARTISTS' MATERIALS, NAMELY, ARTISTS' PASTELS, ARTISTS' PENCILS, ARTISTS' PENS, PENCILS FOR PAINTING AND DRAWING; PAINT BRUSHES; TYPEWRITERS AND OFFICE REQUISITES, NAMELY, PAPER FOLDING MACHINES FOR OFFICE USE, PAPER FEEDING MACHINES FOR OFFICE USE; PACKAGED KITS COMPRISING PRINTED INSTRUCTIONAL, EDUCATIONAL, AND TEACHING MATERIALS FOR EDUCATIONAL ACTIVITY IN THE FIELD OF INTERIOR DECORATING AND ARCHITECTURAL DESIGN; PRINTERS' TYPE; PRINTING BLOCKS (U.S. CLS. 2, 5, 22, 23, 29, 37, 38 AND 50).

**CLASS 35—ADVERTISING AND BUSINESS**

FOR ADVERTISING SERVICES; BUSINESS MANAGEMENT; BUSINESS ADMINISTRATION; OFFICE FUNCTIONS (U.S. CLS. 100, 101 AND 102).

**CLASS 42—SCIENTIFIC AND COMPUTER SERVICES**

FOR INTERIOR DECORATING; INTERIOR DESIGN; ARCHITECTURAL DESIGN SERVICES; ARCHITECTURAL CONSULTATION; GRAPHIC ART DESIGN; INDUSTRIAL DESIGN; DESIGN OF INTERIOR DECOR; PACKAGING DESIGN SERVICES; INTERIOR STYLING SERVICES; CONSTRUCTION DRAFTING; DRAWING UP OF PLANS AND ENGINEERING DRAWINGS (U.S. CLS. 100 AND 101).

KIM MONINGHOFF, EXAMINING ATTORNEY

SN 77-851,142. SAVITHA FAMILY DENTISTRY, DMD, PC, CHANTILLY, VA. FILED 10-17-2009.

**TOOTH FAIRY FAMILY & COSMETIC DENTISTRY**

THE MARK CONSISTS OF STANDARD CHARACTERS WITHOUT CLAIM TO ANY PARTICULAR FONT, STYLE, SIZE, OR COLOR.

NO CLAIM IS MADE TO THE EXCLUSIVE RIGHT TO USE "FAMILY & COSMETIC DENTISTRY", APART FROM THE MARK AS SHOWN.

**CLASS 40—MATERIAL TREATMENT**

FOR DENTAL SERVICES, NAMELY, DENTAL TECHNICIAN SERVICES; DENTAL SERVICES, NAMELY, DENTAL LABORATORIES AND DENTAL LABORATORIES SERVICES (U.S. CLS. 100, 103 AND 106).  
FIRST USE 10-17-2009; IN COMMERCE 10-17-2009.

**CLASS 44—MEDICAL, BEAUTY AND AGRICULTURAL SERVICES**

FOR DENTAL SERVICES, NAMELY, DENTAL IMPLANT SERVICES, DENTAL CROWN SERVICES, AND DENTAL BRIDGE SERVICES; DENTIST SERVICES; COSMETIC DENTISTRY; DENTAL HYGIENIST SERVICES (U.S. CLS. 100 AND 101).

FIRST USE 10-17-2009; IN COMMERCE 10-17-2009.  
JEAN IM, EXAMINING ATTORNEY

SN 77-852,615. FRANCHISE FOUNDRY, LLC, OREM, UT. FILED 10-20-2009.

**Franhive**

THE MARK CONSISTS OF STANDARD CHARACTERS WITHOUT CLAIM TO ANY PARTICULAR FONT, STYLE, SIZE, OR COLOR.



**CLASS 35—ADVERTISING AND BUSINESS**

FOR ADVERTISING, MARKETING AND PROMOTION SERVICES; ADVERTISING, MARKETING AND PROMOTIONAL SERVICES RELATED TO ALL INDUSTRIES FOR THE PURPOSE OF FACILITATING NETWORKING AND SOCIALIZING OPPORTUNITIES FOR BUSINESS PURPOSES; ASSISTANCE, ADVISORY SERVICES AND CONSULTANCY WITH REGARD TO BUSINESS PLANNING, BUSINESS ANALYSIS, BUSINESS MANAGEMENT, BUSINESS ORGANIZATION, MARKETING AND CUSTOMER ANALYSIS; DISSEMINATION OF ADVERTISING, SCHEDULING AND MANAGING OF TRAINING COURSES AND PROGRAMS FOR OTHERS VIA A GLOBAL COMPUTER NETWORK; ON-LINE BUSINESS NETWORKING SERVICES; RECORDS MANAGEMENT SERVICES, NAMELY, DOCUMENT INDEXING FOR OTHERS (U.S. CLS. 100, 101 AND 102).

**CLASS 41—EDUCATION AND ENTERTAINMENT**

FOR PROVIDING ON-LINE ADVERTISING, MARKETING, FRANCHISE OPERATIONS, AND BUSINESS TRAINING COURSES AND DISTRIBUTION OF RELATED COURSE MATERIALS IN CONNECTION THEREWITH, NAMELY, QUIZZES, REPORTS, FORMS, VIDEOS, CERTIFICATES/DIPLOMAS (U.S. CLS. 100, 101 AND 107).

PATRICIA EVANKO, EXAMINING ATTORNEY

---

SN 77-852,713, HOFFMASTER GROUP, INC., INDIANAPOLIS, IN. FILED 10-20-2009.

**ELISE**

THE MARK CONSISTS OF STANDARD CHARACTERS WITHOUT CLAIM TO ANY PARTICULAR FONT, STYLE, SIZE, OR COLOR.

**CLASS 16—PAPER GOODS AND PRINTED MATTER**

FOR PARTY SUPPLIES OF A NON-AUTOMOTIVE THEME AND UNRELATED TO ANY PARTICULAR AUTOMOTIVE MARQUE, NAMELY, PAPER NAPKINS; PAPER TABLE COVERS; PAPER TABLE RUNNERS; FACIAL TISSUES; AND PLACE CARDS (U.S. CLS. 2, 5, 22, 23, 29, 37, 38 AND 50).

**CLASS 21—HOUSEWARES AND GLASS**

FOR PAPER PLATES AND PAPER CUPS (U.S. CLS. 2, 13, 23, 29, 30, 33, 40 AND 50).

**CLASS 24—FABRICS**

FOR PLASTIC TABLE RUNNERS; PLASTIC TABLE COVERS (U.S. CLS. 42 AND 50).

KATHERINE STOIDES, EXAMINING ATTORNEY

SN 77-853,212. SOLO CUP OPERATING CORPORATION, LAKE FOREST, IL. FILED 10-20-2009.



THE MARK CONSISTS OF THREE GEOMETRIC SHAPES RESEMBLING THREE LEAVES.

**CLASS 20—FURNITURE AND ARTICLES NOT OTHERWISE CLASSIFIED**

FOR DISPOSABLE NON-METAL LIDS; DISPOSABLE NON-METAL FOOD CONTAINERS FOR COMMERCIAL USE (U.S. CLS. 2, 13, 22, 25, 32 AND 50).

**CLASS 21—HOUSEWARES AND GLASS**

FOR DISPOSABLE CUPS, PLATES, AND BOWLS; DISPOSABLE FOOD CONTAINERS FOR HOUSEHOLD USE (U.S. CLS. 2, 13, 23, 29, 30, 33, 40 AND 50).  
FIRST USE 3-13-2008; IN COMMERCE 3-13-2008.  
RENEE MCCRAY, EXAMINING ATTORNEY

---

SN 77-853,395. INSUREZONE, INC., FORT WORTH, TX. FILED 10-20-2009.

**BROKERSECURE**

THE MARK CONSISTS OF STANDARD CHARACTERS WITHOUT CLAIM TO ANY PARTICULAR FONT, STYLE, SIZE, OR COLOR.

**CLASS 35—ADVERTISING AND BUSINESS**

FOR BUSINESS CONSULTATION SERVICES, NAMELY, PROVIDING BUSINESS ASSISTANCE IN THE FIELD OF INSURANCE BROKERAGE AND ADMINISTRATION (U.S. CLS. 100, 101 AND 102).  
FIRST USE 7-18-2001; IN COMMERCE 7-18-2001.

**CLASS 36—INSURANCE AND FINANCIAL**

FOR INSURANCE SERVICES, NAMELY, INSURANCE QUOTE PROCESSING AND UNDERWRITING ALL IN THE FIELDS OF COMMERCIAL AND PERSONAL INSURANCE; POLICY SERVICING, NAMELY, PROVIDING INFORMATION IN INSURANCE MATTERS; INSURANCE BROKERAGE, INSURANCE ADMINISTRATION, AND INSURANCE CONSULTATION (U.S. CLS. 100, 101 AND 102).  
FIRST USE 7-18-2001; IN COMMERCE 7-18-2001.

**CLASS 42—SCIENTIFIC AND COMPUTER SERVICES**

FOR APPLICATION SERVICE PROVIDER SERVICES, NAMELY, WEB-BASED COMPUTER APPLICATION HOSTING FOR OTHERS OVER THE GLOBAL COMPUTER NETWORK FOR APPLICATIONS RELATED TO INSURANCE QUOTE PROCESSING AND BINDING, POLICY SERVICING, INSURANCE BROKERAGE, AND INSURANCE ADMINISTRATION (U.S. CLS. 100 AND 101).

FIRST USE 7-18-2001; IN COMMERCE 7-18-2001.  
WILLIAM ROSSMAN, EXAMINING ATTORNEY

---

SN 77-853,666. CENTROSOLAR GROUP AG, 80807 MUNICH, FED REP GERMANY, FILED 10-21-2009.

SUNSHINE IS OUR BUSINESS

THE MARK CONSISTS OF STANDARD CHARACTERS WITHOUT CLAIM TO ANY PARTICULAR FONT, STYLE, SIZE, OR COLOR.

PRIORITY CLAIMED UNDER SEC. 44(D) ON ERPN CMNTY TM OFC APPLICATION NO. 8303174, FILED 5-15-2009, REG. NO. 008303174, DATED 3-29-2010, EXPIRES 5-15-2019.

**CLASS 6—METAL GOODS**

FOR BUILDING MATERIALS AND STRUCTURAL MEMBERS OF METAL, IN PARTICULAR FOR PHOTOVOLTAIC, SOLAR THERMAL OR SOLAR INSTALLATIONS, NAMELY, MODULE FRAMES FOR MOUNTING SOLAR PANELS, MOUNTING SYSTEMS CONSISTING OF, SLATS, END CAPS, COUNTERTOPS, SOFFITS, FASCIA, CORRUGATED METAL SHEETS, FLASHINGS, MOUNTING RAILS, RAIL SPLICES, SPACERS AND PROFILES, AND FASTENING SYSTEMS CONSISTING OF ROOF HOOKS, CLIPS, CLAMPS, BOLTS AND NUTS; BUILDING MATERIALS AND STRUCTURAL MEMBERS OF METAL CONTAINING SOLAR CELLS, SOLAR MODULES AND SOLAR COLLECTORS FOR USE IN TILTED AND FLAT ROOFS, NAMELY, MOUNTING SYSTEMS COMPRISED OF MODULE FRAMES FOR MOUNTING SOLAR PANELS, CORRUGATED METAL SHEETS AND, FLASHINGS; METAL ROOF FLASHING WITH INTEGRATED SOLAR CELLS, SOLAR MODULES OR SOLAR COLLECTORS; RIGID METAL BUILDING PIPES AND METAL FASTENERS, NAMELY, BOLTS, NAILS, RIVETS, SCREWS, CLIPS, LOCKS, ROOF HOOKS, ANCHORS, THREADED BOLTS, L-FOOTS, MOUNTING RAILS, RAIL SPLICES, MODULE CLAMPS AND LAMINATE CLAMPS FOR PHOTOVOLTAIC, SOLAR THERMAL OR SOLAR INSTALLATIONS (U.S. CLS. 2, 12, 13, 14, 23, 25 AND 50).

**CLASS 9—ELECTRICAL AND SCIENTIFIC APPARATUS**

FOR SOLAR CELLS; SPECIAL-PURPOSE GLASS FOR OPTICAL, CHEMICAL, PHYSICAL, ELECTRICAL, ELECTROTECHNICAL, VACUUM-TECHNICAL AND ELECTRONICAL PURPOSES, NAMELY, GLASS COVERED WITH AN ELECTRICAL CONDUCTOR; CONDUCTIVE FIBERS, NAMELY, FLUORIDE GLASS FIBERS; MEASURING, CHECKING AND CONTROL APPARATUS AND INSTRUMENTS, NAMELY, BEVELS, RAIN GAUGES, LASER DISTANCE METER, REMOTE CONTROLS USED FOR THE REGULATION AND CONTROL OF INTERIOR AND EXTERIOR WINDOW BLINDS, TEMPERATURE SENSORS, ELECTRIC WIND SENSORS, AND ELECTRIC SUN SENSORS; APPARATUS AND INSTRUMENTS FOR CONDUCTING, SWITCHING, TRANSFORMING, ACCUMULATING, REGULATING OR CONTROLLING ELECTRICITY, NAMELY, ELECTRIC CONDUCTORS, ELECTRIC SWITCHES, ELECTRIC TRANSFORMERS, ELECTRIC ACCUMULATORS, ELECTRIC COMMUTATORS, ELECTRIC STORAGE BATTERIES AND VOLTAGE REGULATORS FOR ELECTRIC POWER AND AUTOMATIC SWITCHBOARDS; APPARATUS FOR POWER PRODUCTION, NAMELY, APPARATUS FOR THE TRANSFORMATION OF LIGHT INTO ELECTRICITY, NAMELY, SOLAR PANELS FOR PRODUCTION OF ELECTRICITY; SOLAR CONTROLLERS, NAMELY, CONTROLLERS AND ACTUATORS THAT REGULATE THE VOLTAGE TO AVOID AN UNDERLOADING OR OVERLOADING OF A SOLAR BATTERY; MEASURING INSTRUMENTS, IN PARTICULAR POWER INVERTERS AND ELECTRONIC DATA LOGGERS FOR POWER INVERTERS; ELECTRONIC CABLES, WIRES AND CONNECTIVE FITTINGS THEREFOR; PHOTOVOLTAIC SOLAR MODULES; ALL OF THE AFOREMENTIONED GOODS IN PARTICULAR WITH USE IN THE FIELD OF PHOTOVOLTAIC, SOLAR THERMAL AND SOLAR INSTALLATIONS (U.S. CLS. 21, 23, 26, 36 AND 38).

**CLASS 11—ENVIRONMENTAL CONTROL APPARATUS**

FOR SOLAR HEAT COLLECTION PANELS; SOLAR INSTALLATION SYSTEMS FOR HEATING CONSISTING OF BOILERS, VALVES, PIPES, MANIFOLDS, SOLAR PANELS, CONTROL PANEL, SWITCHES AND ELECTRICAL WIRE, ALL SOLD AS A UNIT; THERMAL HEAT PUMPS; SOLAR THERMAL COLLECTORS; SOLAR THERMAL MODULES AND SOLAR COLLECTORS (U.S. CLS. 13, 21, 23, 31 AND 34).

**CLASS 19—NON-METALLIC BUILDING MATERIALS**

FOR BUILDING MATERIALS AND STRUCTURAL MEMBERS, NOT OF METAL, FOR PHOTOVOLTAIC, SOLAR THERMAL AND/OR SOLAR INSTALLATIONS, NAMELY, MODULE FRAMES FOR MOUNTING SOLAR PANELS, MOUNTING SYSTEMS CONSISTING OF SLATS, END CAPS, COUNTERTOPS, SOFFITS, FASCIA, FLASHINGS, PLASTIC MULTI-LAYER PANELS, MOUNTING RAILS, RAIL SPLICES, SPACERS AND PROFILES, NON-METAL BONDING FASTENING SYSTEMS FOR MOUNTING OF CEILING AND WALL PANELS CONSISTING OF ROOF HOOKS, PIPE AND CABLE CLIPS, CLAMPS, BOLTS AND NUTS AND ANTI-SLIP PROTECTIONS; BUILDING MATERIALS AND STRUCTURAL MEMBERS, NOT OF METAL, CONTAINING SOLAR CELLS, SOLAR MODULES AND SOLAR COLLECTORS, NAMELY, MOUNTING SYSTEMS CONSISTING OF ENCAPSULANT FRAMES IN THE NATURE OF SOLAR PANEL MOUNTS, FLASHINGS, AND PLASTIC MULTI-LAYER PANELS; NON-METAL ROOF FLASHING, WITH INTEGRATED SOLAR CELLS, SOLAR MODULES OR SOLAR COLLECTORS; NON-METALLIC PIPES, NAMELY, GUTTER PIPES, WATER PIPES, SEWER PIPES, POLYETHYLENE PIPES FOR GEOTHERMAL HEATING AND COOLING SYSTEMS, PIPES OF POLYPROPYLENE FOR GEOTHERMAL HEATING AND COOLING SYSTEMS AND NON-METALLIC FASTENING SYSTEMS CONSISTING OF MOUNTING RAILS AND RAIL SPLICES FOR ALL FOR USE WITH PHOTOVOLTAIC, SOLAR THERMAL AND/OR SOLAR INSTALLATIONS (U.S. CLS. 1, 12, 33 AND 50).

**CLASS 37—CONSTRUCTION AND REPAIR**

FOR INSTALLATION, REPAIR AND MAINTENANCE OF PHOTOVOLTAIC, SOLAR AND SOLAR THERMAL INSTALLATIONS AS WELL AS COMPONENTS AND ACCESSORIES THEREFOR; CONSTRUCTION PLANNING AND CONSULTANCY FOR SOLAR ENERGY USE; CONSULTANCY FOR SOLAR ENERGY USE, NAMELY, HOME ENERGY ASSESSMENT SERVICES FOR THE PURPOSE OF DETERMINING HOME IMPROVEMENTS NEEDED TO IMPROVE SOLAR ENERGY USE AND EFFICIENCY (U.S. CLS. 100, 103 AND 106).

**CLASS 40—MATERIAL TREATMENT**

FOR POWER PRODUCTION, IN PARTICULAR PRODUCTION OF SOLAR ENERGY FOR THE PURPOSE OF GENERATING ELECTRICITY; TREATMENT OF MATERIALS FOR THE MANUFACTURE OF PARTS FOR SOLAR, SOLAR THERMAL AND PHOTOVOLTAIC INSTALLATIONS AND THEIR COMPONENTS AND ACCESSORIES; CONSULTANCY IN THE FIELD OF POWER PRODUCTION, NAMELY, TECHNICAL CONSULTATION IN THE FIELD OF SOLAR ENERGY PRODUCTION; ASSEMBLY FOR OTHERS OF PHOTOVOLTAIC, SOLAR AND SOLAR THERMAL INSTALLATIONS AS WELL AS COMPONENTS AND ACCESSORIES THEREFOR; TECHNICAL CONSULTANCY AND EXPERT OPINIONS IN CONNECTION WITH SOLAR ENERGY TECHNOLOGY (U.S. CLS. 100, 103 AND 106).

**CLASS 42—SCIENTIFIC AND COMPUTER SERVICES**

FOR BUILDING PLANNING; ENGINEERING SERVICES; TECHNICAL PLANNING OF SOLAR ENERGY BASED POWER PLANTS AND OF SOLAR THERMAL AND PHOTOVOLTAIC INSTALLATIONS AS WELL AS COMPONENTS AND ACCESSORIES THEREFOR; TECHNICAL CONSULTANCY AND EXPERT OPINIONS IN CONNECTION WITH SOLAR TECHNOLOGY, SOLAR THERMAL AND PHOTOVOLTAIC INSTALLATIONS (U.S. CLS. 100 AND 101).

MEGHAN REINHART, EXAMINING ATTORNEY

SN 77-855,108. THE ENDURANCE INTERNATIONAL GROUP, INC., BURLINGTON, MA. FILED 10-22-2009.

# DOT5HOSTING

THE MARK CONSISTS OF STANDARD CHARACTERS WITHOUT CLAIM TO ANY PARTICULAR FONT, STYLE, SIZE, OR COLOR.

**CLASS 35—ADVERTISING AND BUSINESS**

FOR E-COMMERCE SERVICES, NAMELY, COORDINATION OF MARKETING AND ADVERTISING SERVICES FOR OTHERS (U.S. CLS. 100, 101 AND 102).  
FIRST USE 0-0-2007; IN COMMERCE 0-0-2007.

**CLASS 38—COMMUNICATION**

FOR ELECTRONIC MAIL SERVICES; EMAIL AND WEBSITE FORWARDING SERVICES; PROVIDING MULTIPLE USER-ACCESS TO A GLOBAL COMPUTER INFORMATION NETWORK (U.S. CLS. 100, 101 AND 104).

FIRST USE 0-0-2002; IN COMMERCE 0-0-2002.

**CLASS 42—SCIENTIFIC AND COMPUTER SERVICES**

FOR COMPUTER SERVICES, NAMELY, DOMAIN NAME SEARCHING SERVICES FOR THE PURPOSE OF FINDING URL ADDRESSES, SPECIFICALLY, CONDUCTING ONLINE COMPUTERIZED SEARCHES FOR THE AVAILABILITY OF DOMAIN NAMES TO BE USED IN URL ADDRESSES; DESIGN, CREATION, HOSTING, AND MAINTENANCE OF WEBSITES FOR OTHERS ON A GLOBAL COMPUTER NETWORK; PROVIDING INFORMATION REGARDING WEBSITE DEVELOPMENT; COMPUTER WEBSITE DESIGN CONSULTATION; PROVIDING TEMPORARY USE OF ON-LINE NON-DOWNLOADABLE COMPUTER SOFTWARE DEVELOPMENT TOOLS FOR CREATING WEB SITES, ONLINE STORES, ELECTRONIC BULLETIN BOARDS, AND BLOGS; TECHNICAL SUPPORT, NAMELY, MONITORING THE PERFORMANCE OF WEBSITES FOR PURPOSES OF REPORTING ANY ERRORS RELATED TO WEB SITE TRAFFIC; COMPUTER VIRUS PROTECTION SERVICES; TECHNICAL SUPPORT, NAMELY, TROUBLESHOOTING OF COMPUTER SOFTWARE PROBLEMS; PROVIDING TECHNICAL SUPPORT IN THE NATURE OF TROUBLESHOOTING OF COMPUTER SOFTWARE PROBLEMS AND CONSULTATION RELATED THERETO, ALL IN THE FIELDS OF DOMAIN NAME REGISTRATION, WEBSITE DESIGN SERVICES, WEB HOSTING SERVICES, WEBSITE MAINTENANCE, ELECTRONIC MAIL SERVICES, BLOG DEVELOPMENT AND MAINTENANCE, E-COMMERCE SERVICES, AND DESIGN AND MAINTENANCE OF ONLINE RETAIL STORES; PROVIDING TEMPORARY USE OF NON-DOWNLOADABLE SOFTWARE FOR USE IN E-COMMERCE SERVICES TO ALLOW USERS TO PERFORM ELECTRONIC TRANSACTIONS AND DESIGN AND DEVELOP PROMOTIONAL AND MARKETING CAMPAIGNS (U.S. CLS. 100 AND 101).

FIRST USE 0-0-2002; IN COMMERCE 0-0-2002.

**CLASS 45—PERSONAL AND LEGAL SERVICES**

FOR REGISTRATION SERVICES ENABLING ENTITIES TO MANAGE INFORMATION RELATED TO DOMAIN NAMES FOR USE ON A GLOBAL COMPUTER NETWORK, NAMELY, REGISTRATION OF DOMAIN NAMES; MONITORING OF COMPUTER SYSTEMS FOR SECURITY PURPOSES; DOMAIN NAME REGISTRATION CONSULTATION (U.S. CLS. 100 AND 101).

FIRST USE 0-0-2002; IN COMMERCE 0-0-2002.

MAUREEN DALL, EXAMINING ATTORNEY

SN 77-857,772. ARP AMERICAN RESEARCH PRODUCTS, INC., BELMONT, MA. FILED 10-26-2009.



NO CLAIM IS MADE TO THE EXCLUSIVE RIGHT TO USE "PRODUCTS, INC.", APART FROM THE MARK AS SHOWN.

SEC. 2(F) AS TO "AMERICAN RESEARCH PRODUCTS, INC."

**CLASS 1—CHEMICALS**

FOR ASSAYS FOR RESEARCH PURPOSES; BIOCHEMICALS, NAMELY, MONOCLONAL ANTIBODIES FOR IN VITRO SCIENTIFIC OR RESEARCH USE; BIOCHEMICALS, NAMELY, POLYPEPTIDES FOR IN VITRO RESEARCH USE; BIOMEDICAL COMPOUNDS, NAMELY, PEPTIDE SUBSTRATES USED IN ANALYZING AND DETECTING CERTAIN TOXINS FOR LABORATORY OR RESEARCH USE; DIAGNOSTIC KITS CONSISTING PRIMARILY OF MONOCLONAL ANTIBODIES, BUFFERS, AND REAGENTS TO MONITOR TOXICITY OF DRUGS; DIAGNOSTIC REAGENTS FOR IN VITRO USE IN BIOCHEMISTRY, CLINICAL CHEMISTRY AND MICROBIOLOGY; ENZYMES FOR SCIENTIFIC AND RESEARCH PURPOSES; REAGENTS FOR RESEARCH PURPOSES (U.S. CLS. 1, 5, 6, 10, 26 AND 46).  
FIRST USE 2-22-2009; IN COMMERCE 2-22-2009.

**CLASS 5—PHARMACEUTICALS**

FOR DIAGNOSTIC KITS CONSISTING PRIMARILY OF MONOCLONAL ANTIBODIES, BUFFERS, AND REAGENTS FOR USE IN DISEASE TESTING (U.S. CLS. 6, 18, 44, 46, 51 AND 52).  
FIRST USE 2-22-2009; IN COMMERCE 2-22-2009.  
KATHRYN COWARD, EXAMINING ATTORNEY

**CLASS 41—EDUCATION AND ENTERTAINMENT**

FOR ENTERTAINMENT, NAMELY, LIVE PERFORMANCES BY A MUSICAL BAND; MUSIC PRODUCTION SERVICES; ARTIST DEVELOPMENT, NAMELY, ENTERTAINMENT AND EDUCATIONAL SERVICES, PROVIDING ADVICE AND INFORMATION FOR MUSIC, VIDEO AND FILM CONCEPT, AND SCRIPT DEVELOPMENT; ARTIST PUBLISHING, NAMELY, MUSIC PUBLISHING SERVICES; CD PRODUCTION, NAMELY, MUSIC PRODUCTION SERVICES; DISTRIBUTION OF RADIO PROGRAMS; ENTERTAINMENT SERVICES IN THE NATURE OF AUDIO VISUAL ENTERTAINMENT, NAMELY, MUSICAL SHOWS AND MUSICAL ENTERTAINMENT, NAMELY, LIVE PERFORMANCES BY MUSICAL BANDS; FILM PRODUCTION; TELEVISION PRODUCTION, NAMELY, PRODUCTION OF TELEVISION PROGRAMS (U.S. CLS. 100, 101 AND 107).  
JESSICA FATHY, EXAMINING ATTORNEY

SN 77-858,267. J&L MARKETING, INC., LOUISVILLE, KY.  
FILED 10-27-2009.

SN 77-858,058. VELVETBOX INC., OTTAWA, ONTARIO, CANADA, FILED 10-27-2009.

**VELVETBOX**

THE MARK CONSISTS OF STANDARD CHARACTERS WITHOUT CLAIM TO ANY PARTICULAR FONT, STYLE, SIZE, OR COLOR.

PRIORITY CLAIMED UNDER SEC. 44(D) ON CANADA APPLICATION NO. 1453544, FILED 9-29-2009, REG. NO. TMA788684, DATED 1-26-2011, EXPIRES 1-26-2026.

**CLASS 3—COSMETICS AND CLEANING PREPARATIONS**

FOR FRAGRANCES (U.S. CLS. 1, 4, 6, 50, 51 AND 52).

**CLASS 9—ELECTRICAL AND SCIENTIFIC APPARATUS**

FOR PRE-RECORDED CDS FEATURING MUSICAL ENTERTAINMENT; VINYL RECORDS FEATURING MUSICAL ENTERTAINMENT; DIGITAL DOWNLOADS IN THE FIELD OF MUSICAL ENTERTAINMENT (U.S. CLS. 21, 23, 26, 36 AND 38).

**CLASS 25—CLOTHING**

FOR T-SHIRTS; HATS; UNDERWEAR; JACKETS; SUITS (U.S. CLS. 22 AND 39).

**BCOMPELLING**

THE MARK CONSISTS OF STANDARD CHARACTERS WITHOUT CLAIM TO ANY PARTICULAR FONT, STYLE, SIZE, OR COLOR.

**CLASS 35—ADVERTISING AND BUSINESS**

FOR BUSINESS AND ADVERTISING SERVICES IN THE NATURE OF DEVELOPING AND PROVIDING DIRECT RESPONSE MARKETING SERVICES FOR OTHERS; BUSINESS AND ADVERTISING SERVICES IN THE NATURE OF DEVELOPING AND PROVIDING PROMOTIONAL FORMS AND ADVERTISING MATERIALS FOR OTHERS (U.S. CLS. 100, 101 AND 102).

**CLASS 42—SCIENTIFIC AND COMPUTER SERVICES**

FOR DEVELOPING WEBSITES FOR OTHERS FOR DIRECT MARKETING PURPOSES; DEVELOPING WEBSITES FOR OTHERS TO FACILITATE MARKETING EVENTS AND CAMPAIGNS (U.S. CLS. 100 AND 101).  
NAPOLEON SHARMA, EXAMINING ATTORNEY

SN 77-860,349. OPEL, INC., SHELTON, CT. FILED 10-29-2009.

**OPEL**

THE MARK CONSISTS OF STANDARD CHARACTERS WITHOUT CLAIM TO ANY PARTICULAR FONT, STYLE, SIZE, OR COLOR.  
SEC. 2(F).

**CLASS 6—METAL GOODS**

FOR METAL STRUCTURES FOR MOUNTING SOLAR PANELS SOLAR PANEL MOUNTS MADE OF METAL; SUBSTRATES PRIMARILY OF METAL FOR SUPPORTING SOLAR CELLS, PHOTOVOLTAIC CELLS AND SOLAR COLLECTORS (U.S. CLS. 2, 12, 13, 14, 23, 25 AND 50).

FIRST USE 6-1-2006; IN COMMERCE 6-1-2006.

**CLASS 7—MACHINERY**

FOR MOTORS, GEARS AND DRIVES FOR ORIENTATING SOLAR PANELS (U.S. CLS. 13, 19, 21, 23, 31, 34 AND 35).

FIRST USE 6-1-2006; IN COMMERCE 6-1-2006.

**CLASS 9—ELECTRICAL AND SCIENTIFIC APPARATUS**

FOR APPARATUS FOR CONVERTING SOLAR RADIATION TO ELECTRICAL ENERGY, NAMELY, PHOTOVOLTAIC SOLAR MODULES, PHOTOVOLTAIC SOLAR HYBRID MODULES, PHOTOVOLTAIC THERMAL MODULE, PVT MODULE AND SOLAR CONCENTRATING PANELS; APPARATUS FOR CONVERTING ELECTRONIC RADIATION TO ELECTRICAL ENERGY, NAMELY, PHOTOVOLTAIC SOLAR MODULES AND PHOTOVOLTAIC ROOFING MEMBERS; HEAT SINKS FOR TRIPLE JUNCTION PHOTOVOLTAIC CELLS; HEAT SINKS FOR USE IN PHOTOVOLTAIC CELLS AND ELECTRONIC COMPONENTS CONCENTRATORS; MAGNIFYING LENSES AND OPTICAL LENSES; PHOTOVOLTAIC CELLS AND MODULES; SILICON SOLAR CELL MATERIAL FOR ELECTRICITY GENERATION INCORPORATED INTO PAVEMENT MATERIALS; AND SOLAR CELLS (U.S. CLS. 21, 23, 26, 36 AND 38).

FIRST USE 6-1-2006; IN COMMERCE 6-1-2006.

**CLASS 11—ENVIRONMENTAL CONTROL APPARATUS**

FOR HEAT SINKS FOR USE IN HEATING, COOLING AND VENTILATING APPARATUS; PHOTOVOLTAIC-BASED POWER PLANTS; HEAT SINKS FOR USE IN HEATING, COLLING AND VENTILATING APPARATUS, NAMELY, SOLAR CONCENTRATORS AND COLLECTORS (U.S. CLS. 13, 21, 23, 31 AND 34).

FIRST USE 6-1-2006; IN COMMERCE 6-1-2006.

**CLASS 17—RUBBER GOODS**

FOR SUBSTRATES PRIMARILY OF CERAMIC SILICON AND NON-METALS FOR ELECTRICAL OR THERMAL INSULATION OF SOLAR CELLS, PHOTOVOLTAIC CELLS, AND SOLAR COLLECTORS (U.S. CLS. 1, 5, 12, 13, 35 AND 50).

FIRST USE 6-1-2006; IN COMMERCE 6-1-2006.

**CLASS 19—NON-METALLIC BUILDING MATERIALS**

FOR NON-METAL STRUCTURES FOR MOUNTING SOLAR PANELS (U.S. CLS. 1, 12, 33 AND 50).

FIRST USE 6-1-2006; IN COMMERCE 6-1-2006.

**CLASS 37—CONSTRUCTION AND REPAIR**

FOR INSTALLATION AND MAINTENANCE OF PHOTOVOLTAIC INSTALLATIONS (U.S. CLS. 100, 103 AND 106).

FIRST USE 6-1-2006; IN COMMERCE 6-1-2006.

**CLASS 42—SCIENTIFIC AND COMPUTER SERVICES**

FOR DESIGN OF SOLAR PHOTOVOLTAIC SYSTEMS; DRAFTING AND DEVELOPMENT OF PHOTOVOLTAIC SYSTEMS; TECHNICAL PLANNING OF PHOTOVOLTAIC INSTALLATIONS (U.S. CLS. 100 AND 101).

FIRST USE 6-1-2006; IN COMMERCE 6-1-2006.  
LOURDES AYALA, EXAMINING ATTORNEY

SN 77-863,338. RED PANDA NETWORK, MOUNTAIN VIEW, CA. FILED 11-2-2009.



**RED PANDA  
NETWORK**

NO CLAIM IS MADE TO THE EXCLUSIVE RIGHT TO USE "RED PANDA NETWORK", APART FROM THE MARK AS SHOWN.

THE MARK CONSISTS OF THE WORDING "RED PANDA NETWORK" TO THE RIGHT OF A STYLIZED DESIGN OF A RED PANDA HEAD.

**CLASS 35—ADVERTISING AND BUSINESS**

FOR PROMOTING PUBLIC AWARENESS IN THE FIELD OF RED PANDAS, THE PLIGHT OF RED PANDAS IN THE WILD, AND THE IMPORTANCE OF RED PANDA PROTECTION (U.S. CLS. 100, 101 AND 102).

FIRST USE 8-1-2007; IN COMMERCE 8-1-2007.

**CLASS 41—EDUCATION AND ENTERTAINMENT**

FOR EDUCATIONAL SERVICES IN THE NATURE OF CLASSES, SEMINARS AND WORKSHOPS IN THE FIELD OF PROTECTION OF RED PANDAS IN THE WILD (U.S. CLS. 100, 101 AND 107).

FIRST USE 8-1-2007; IN COMMERCE 8-1-2007.

**CLASS 42—SCIENTIFIC AND COMPUTER SERVICES**

FOR RESEARCH IN THE FIELD OF PROTECTION OF RED PANDAS IN THE WILD; SCIENTIFIC RESEARCH IN THE FIELD OF PROTECTION OF RED PANDAS IN THE WILD, NAMELY, HABITAT PROTECTION STUDIES (U.S. CLS. 100 AND 101).

FIRST USE 8-1-2007; IN COMMERCE 8-1-2007.

KAREN SEVERSON, EXAMINING ATTORNEY

SN 77-863,390. RNL BIO CO., LTD., GWNAK-GU, REPUBLIC OF KOREA, FILED 11-2-2009.

**LIPOSTEM**

THE MARK CONSISTS OF STANDARD CHARACTERS WITHOUT CLAIM TO ANY PARTICULAR FONT, STYLE, SIZE, OR COLOR.

**CLASS 5—PHARMACEUTICALS**

FOR PHARMACEUTICAL PREPARATIONS TO CULTURE BIOLOGICAL CELLS FOR THERAPEUTIC USE; DIAGNOSTIC AND THERAPEUTIC PREPARATIONS OF STEM CELLS, STEM CELL DERIVATIVES, AND STEM CELL BYPRODUCTS FOR MEDICAL, CLINICAL, AND VETERINARY PURPOSES; STEM CELLS, STEM CELL DERIVATIVES, AND STEM CELL BYPRODUCTS FOR DIAGNOSTIC AND THERAPEUTIC MEDICAL, CLINICAL, VETERINARY PURPOSES (U.S. CLS. 6, 18, 44, 46, 51 AND 52).

**CLASS 44—MEDICAL, BEAUTY AND AGRICULTURAL SERVICES**

FOR CLINICAL THERAPEUTIC MEDICAL AND VETERINARY SERVICES, FEATURING RETRIEVAL, PREPARATION, TREATMENT, AND TRANSPLANTATION WITH BIOLOGICAL MATERIALS SUCH AS STEM CELLS, STEM CELL DERIVATIVES, AND STEM CELL BYPRODUCTS (U.S. CLS. 100 AND 101).

HOWARD B. LEVINE, EXAMINING ATTORNEY

SN 77-866,092. DR. KLATZ, RONALD, NEW YORK, NY. FILED S.R. 11-5-2009; AM. P.R. 8-9-2010.



NO CLAIM IS MADE TO THE EXCLUSIVE RIGHT TO USE "LONGEVITY MAGAZINE E-JOURNAL", APART FROM THE MARK AS SHOWN.

THE MARK CONSISTS OF THE WORDS "LONGEVITY MAGAZINE E-JOURNAL" AND TWO PRIMARY DESIGN ELEMENTS FRAMED IN A RECTANGULAR BORDER. BETWEEN THE WORDS "LONGEVITY" AND "MAGAZINE" IS A DESIGN ELEMENT CONSISTING OF A OUTLINED DRAWING OF A GALAPAGOS TORTOISE. THE GALAPAGOS TORTOISE IS SLANTED WITH ITS HEAD POINTING IN A NORTH-WEST DIRECTION. SET IN THE BACKGROUND OF THE WORD "LONGEVITY" AND THE GALAPAGOS TORTOISE IS A SECOND DESIGN ELEMENT REPRESENTING THE GLOBE CONSISTING OF OUTSIDE CURVED LINE WITH ADDITIONAL OFFSET HORIZONTAL AND VERTICAL CURVED LINES (REPRESENTING LONGITUDINAL AND LATITUDINAL LINES ON A GLOBE). BELOW THE WORD "MAGAZINE" AND ALIGNED TO THE RIGHT OF IT IS THE WORD "E-JOURNAL". THE DASH BETWEEN "E" AND "JOURNAL" IS IN FACT A BOLD DOT (SYMBOL) AND THE WORD "JOURNAL" IS IN CAPS. THE FONTS OF THE WORDS ARE AS FOLLOWS: (I) "LONGEVITY" IS IN HELVETICA NEUE BOLD CONDENSED; (II) "MAGAZINE" IS IN HELVETICA NEUE CONDENSED; (III) THE "E" OF "E-JOURNAL" IS IN ADOBE GARAMOND PRO ITALIC; (V) "." OF "E-JOURNAL" IS IN FACT A BOLD DOT AND IS IN HELVETICA NEUE CONDENSED; AND (VI) "JOURNAL" OF "E-JOURNAL" IS IN HELVETICA NEUE MEDIUM CONDENSED. FONTS ARE PROVIDED FOR DESCRIPTIVE PURPOSES ONLY.

**CLASS 9—ELECTRICAL AND SCIENTIFIC APPARATUS**

FOR ELECTRONIC PUBLICATIONS, NAMELY, MAGAZINES FEATURING ANTI-AGING, WELLNESS, NUTRITION, BEAUTY CONTENT RECORDED ON COMPUTER MEDIA; DOWNLOADABLE MP3 FILES, MP3 RECORDINGS, ONLINE DISCUSSION BOARDS, WEBCASTS AND PODCASTS FEATURING MUSIC, AUDIO BOOKS AND NEWS BROADCASTS (U.S. CLS. 21, 23, 26, 36 AND 38).

FIRST USE 11-5-2009; IN COMMERCE 11-5-2009.

**CLASS 16—PAPER GOODS AND PRINTED MATTER**

FOR MAGAZINE COLUMNS ABOUT ANTI-AGING, WELLNESS, NUTRITION, BEAUTY; MAGAZINE SECTIONS IN THE FIELD OF ANTI-AGING, WELLNESS, NUTRITION, BEAUTY; MAGAZINE SUPPLEMENTS TO NEWSPAPERS IN THE FIELD OF ANTI-AGING, WELLNESS, NUTRITION, BEAUTY; MAGAZINES FEATURING ANTI-AGING, WELLNESS, NUTRITION, BEAUTY CONTENT (U.S. CLS. 2, 5, 22, 23, 29, 37, 38 AND 50).

FIRST USE 11-5-2009; IN COMMERCE 11-5-2009.

**CLASS 35—ADVERTISING AND BUSINESS**

FOR DISSEMINATION OF ADVERTISEMENTS AND OF ADVERTISING MATERIAL; PROMOTION, ADVERTISING AND MARKETING OF ON-LINE WEBSITES (U.S. CLS. 100, 101 AND 102).

FIRST USE 11-5-2009; IN COMMERCE 11-5-2009.

**CLASS 38—COMMUNICATION**

FOR BROADCAST OF CABLE TELEVISION PROGRAMS; BROADCASTING OF RADIO AND TELEVISION PROGRAMS; BROADCASTING PROGRAMS VIA A GLOBAL COMPUTER NETWORK (U.S. CLS. 100, 101 AND 104).

FIRST USE 11-5-2009; IN COMMERCE 11-5-2009.

**CLASS 41—EDUCATION AND ENTERTAINMENT**

FOR PUBLICATION OF MAGAZINES; PUBLICATION OF TEXTS, BOOKS, MAGAZINES AND OTHER PRINTED MATTER; PUBLISHING OF ELECTRONIC PUBLICATIONS; PUBLISHING OF WEB MAGAZINES; MULTIMEDIA PUBLISHING OF BOOKS, MAGAZINES, JOURNALS, SOFTWARE, GAMES, MUSIC, AND ELECTRONIC PUBLICATIONS; ONLINE ELECTRONIC PUBLISHING OF BOOKS AND PERIODICALS; ORGANIZATION OF CONFERENCES AND SYMPOSIA IN THE FIELD OF MEDICAL SCIENCE; EDUCATION SERVICES, NAMELY, PROVIDING CONFERENCES, SEMINARS, WORKSHOPS IN THE FIELD OF ANTI-AGING, WELLNESS, NUTRITION, BEAUTY; EDUCATIONAL SERVICES, NAMELY, DEVELOPING, ARRANGING, AND CONDUCTING EDUCATIONAL CONFERENCES AND PROGRAMS AND PROVIDING COURSES OF INSTRUCTION IN THE FIELD OF ANTI-AGING, WELLNESS, NUTRITION, BEAUTY; EDUCATIONAL AND ENTERTAINMENT SERVICES, NAMELY, A CONTINUING PROGRAM ABOUT ANTI-AGING, WELLNESS, NUTRITION, BEAUTY ACCESSIBLE BY RADIO, TELEVISION, SATELLITE, AUDIO, VIDEO AND COMPUTER NETWORKS (U.S. CLS. 100, 101 AND 107).

FIRST USE 11-5-2009; IN COMMERCE 11-5-2009.  
KATHY DE JONGE, EXAMINING ATTORNEY

SN 77-866,889. FITNESS QUEST INC., CANTON, OH. FILED 11-6-2009.

**New You Next Week**

THE MARK CONSISTS OF STANDARD CHARACTERS WITHOUT CLAIM TO ANY PARTICULAR FONT, STYLE, SIZE, OR COLOR.

**CLASS 9—ELECTRICAL AND SCIENTIFIC APPARATUS**

FOR PRE-RECORDED MEDIA, NAMELY, VIDEO TAPES, DVDS, AND CDS FEATURING PHYSICAL EXERCISE SHOWS OR INFORMATION; DOWNLOADABLE ELECTRONIC PUBLICATIONS, NAMELY, NEWSLETTERS FEATURING DIET, HEALTHCARE, AND FITNESS INFORMATION (U.S. CLS. 21, 23, 26, 36 AND 38).

**CLASS 16—PAPER GOODS AND PRINTED MATTER**

FOR PRINTED PUBLICATIONS, NAMELY, BOOKS AND BOOKLETS FEATURING FITNESS, DIETARY AND HEALTHCARE INFORMATION (U.S. CLS. 2, 5, 22, 23, 29, 37, 38 AND 50).

**CLASS 38—COMMUNICATION**

FOR ELECTRONIC MAIL SERVICES FOR DATA, FEATURING NEWSLETTERS IN THE FIELDS OF DIET, HEALTHCARE, AND FITNESS INFORMATION (U.S. CLS. 100, 101 AND 104).

**CLASS 44—MEDICAL, BEAUTY AND AGRICULTURAL SERVICES**

FOR PROVIDING DIET, HEALTHCARE, AND FITNESS INFORMATION VIA THE INTERNET OVER LOCAL AND WORLDWIDE COMPUTER NETWORKS (U.S. CLS. 100 AND 101).

TRACY WHITTAKER-BROWN, EXAMINING ATTORNEY

SN 77-869,424. SUIT HOUSE, INC., PLAINFIELD, IL. FILED 11-10-2009.

---

# SUITHOUSE

---

THE MARK CONSISTS OF STANDARD CHARACTERS WITHOUT CLAIM TO ANY PARTICULAR FONT, STYLE, SIZE, OR COLOR.

**CLASS 25—CLOTHING**

FOR CLOTHING, NAMELY, SUITS, SPORTS COATS, BLAZERS, COATS, JACKETS, PANTS, SHORTS, SHIRTS, SWEATERS, DRESSES, SKIRTS, BLOUSES, TANK TOPS, SLEEPWEAR, ROBES, JUMPSUITS, JEANS, UNDERWEAR, SWIMSUITS, T-SHIRTS, TUXEDOS, VESTS, NECKWEAR, HOSIERY, GLOVES, SCARVES, HEADWEAR, SWEATSHIRTS, SWEATPANTS, BELTS, CUMMERBUNDS, SUSPENDERS, SOCKS, FOOTWEAR (U.S. CLS. 22 AND 39).

**CLASS 35—ADVERTISING AND BUSINESS**

FOR RETAIL AND ONLINE STORE SERVICES FEATURING CLOTHING (U.S. CLS. 100, 101 AND 102).

TEJBIR SINGH, EXAMINING ATTORNEY

SN 77-870,295. RNL BIO CO. LTD., GWNAK-GU, REPUBLIC OF KOREA, FILED 11-11-2009.

---

# RNL Life Science

---

THE MARK CONSISTS OF STANDARD CHARACTERS WITHOUT CLAIM TO ANY PARTICULAR FONT, STYLE, SIZE, OR COLOR.

NO CLAIM IS MADE TO THE EXCLUSIVE RIGHT TO USE "LIFE SCIENCE", APART FROM THE MARK AS SHOWN.

**CLASS 35—ADVERTISING AND BUSINESS**

FOR RETAIL STORES, ONLINE RETAIL STORES, MAIL ORDER SERVICES, AND WHOLESALE ORDERING SERVICES, ALL OF THE AFOREMENTIONED FEATURING STEM CELLS, STEM CELL DERIVATIVES, AND STEM CELL BYPRODUCTS (U.S. CLS. 100, 101 AND 102).

FIRST USE 8-31-2000; IN COMMERCE 2-28-2009.

**CLASS 44—MEDICAL, BEAUTY AND AGRICULTURAL SERVICES**

FOR MEDICAL SERVICES FEATURING THE USE OF STEM CELLS, STEM CELL DERIVATIVES, AND STEM CELL BYPRODUCTS; VETERINARY SERVICES FEATURING THE USE OF STEM CELLS, STEM CELL DERIVATIVES, AND STEM CELL BYPRODUCTS; DISPENSING OF PHARMACEUTICALS FEATURING STEM CELLS, STEM CELL DERIVATIVES, AND STEM CELL BYPRODUCTS; MEDICAL SERVICES FEATURING THE HARVESTING AND TRANSPORTATION OF STEM CELLS; ISOLATION, COLLECTION, AND BANKING OF STEM CELLS (U.S. CLS. 100 AND 101).

FIRST USE 8-31-2000; IN COMMERCE 2-28-2009.  
ELI HELLMAN, EXAMINING ATTORNEY

SN 77-874,337. QUIET RIOTS LTD, RICHMOND, SURREY, UNITED KINGDOM, FILED 11-17-2009.

---

# QUIET RIOTS

---

THE MARK CONSISTS OF STANDARD CHARACTERS WITHOUT CLAIM TO ANY PARTICULAR FONT, STYLE, SIZE, OR COLOR.

PRIORITY CLAIMED UNDER SEC. 44(D) ON ERPN CMNTY TM OFC APPLICATION NO. 008310121, FILED 5-19-2009, REG. NO. 008310121, DATED 11-22-2009, EXPIRES 5-19-2019.

OWNER OF ERPN CMNTY TM OFC REG. NO. 008310121, DATED 11-22-2009, EXPIRES 5-19-2019.

**CLASS 9—ELECTRICAL AND SCIENTIFIC APPARATUS**

FOR DOWNLOADABLE ELECTRONIC PUBLICATIONS IN THE NATURE OF NEWSLETTERS ADDRESSING AND PROMOTING ISSUES RELATED TO CULTURAL, ECONOMIC, ENVIRONMENTAL, GOVERNMENTAL AND SOCIAL CHANGE; RECORDED DISCS, DVDS AND C-ROMS FEATURING SOFTWARE AND PROGRAMS RELATED TO ADDRESSING AND PROMOTING ISSUES RELATED TO CULTURAL, ECONOMIC, ENVIRONMENTAL, GOVERNMENTAL AND SOCIAL CHANGE; INFORMATION STORED ON ELECTRONIC, MAGNETIC AND/OR BY OPTICAL MEANS, NAMELY, PROGRAMS RELATED TO ADDRESSING AND PROMOTING ISSUES RELATED TO CULTURAL, ECONOMIC, ENVIRONMENTAL, GOVERNMENTAL AND SOCIAL CHANGE; COMPUTER SOFTWARE PROVIDING PLATFORMS ALLOWING INDIVIDUALS TO JOIN TOGETHER IN GROUPS TO ADDRESS AND PROMOTE ISSUES RELATED TO CULTURAL, ECONOMIC, ENVIRONMENTAL, GOVERNMENTAL AND SOCIAL CHANGE; DOWNLOADABLE SOFTWARE PROVIDING A PLATFORM THAT ALLOWS INDIVIDUALS TO JOIN TOGETHER IN GROUPS TO ADDRESS AND PROMOTE ISSUES RELATED TO CULTURAL, ECONOMIC, ENVIRONMENTAL, GOVERNMENTAL AND SOCIAL CHANGE; ELECTRONIC PUBLICATIONS AND INFORMATION, NAMELY, NEWSLETTERS IN THE FIELD OF ADDRESSING AND PROMOTING ISSUES RELATED TO CULTURAL, ECONOMIC, ENVIRONMENTAL, GOVERNMENTAL AND SOCIAL CHANGE PROVIDED ON-LINE FROM A DATABASE OR FROM FACILITIES PROVIDED ON THE INTERNET OR OTHER NETWORKS; SOFTWARE TO ENABLE UPLOADING, POSTING, BLOGGING, INSTANT MESSAGING AND SHARING OF COMMUNICATION OR INFORMATION; COMPUTER SOFTWARE RELATING TO SOCIAL NETWORKING AND ON-LINE COMMUNITIES THAT ALLOWS INDIVIDUALS TO JOIN TOGETHER IN GROUPS TO ADDRESS AND PROMOTE ISSUES RELATED TO CULTURAL, ECONOMIC, ENVIRONMENTAL, GOVERNMENTAL AND SOCIAL CHANGE; COMPUTER SOFTWARE FOR ALLOWING DATA RETRIEVAL, UPLOAD, ACCESS AND MANAGEMENT; COMPUTER SOFTWARE THAT ENABLES USERS TO CREATE AND/OR SHARE MULTIMEDIA CONTENT WITH THIRD PARTIES VIA A GLOBAL COMPUTER NETWORK (U.S. CLS. 21, 23, 26, 36 AND 38).

**CLASS 35—ADVERTISING AND BUSINESS**

FOR MARKET RESEARCH; ADVISORY SERVICES RELATING TO MARKET RESEARCH; ANALYSIS OF MARKET RESEARCH DATA; MARKET SURVEILLANCE; COLLECTION OF MARKET RESEARCH INFORMATION; INTERPRETATION OF MARKET RESEARCH DATA; PROVISION OF MARKET RESEARCH INFORMATION; RESEARCH SERVICES RELATING TO MARKETING; RESEARCH SERVICES RELATED TO ASCERTAINING THE PERCEPTIONS AND INSIGHTS OF CONSUMERS AND BUSINESSES; BUSINESS INFORMATION SERVICES; BUSINESS ADVICE AND ANALYSIS OF MARKETS; CONSUMER MARKET INFORMATION SERVICES; CONSUMER RESEARCH; CONSUMER RESPONSE ANALYSIS; COMMERCIAL INFORMATION AND ADVICE FOR CONSUMERS; ONLINE INTERACTIVE CONSUMER ADVICE SERVICES; ASSISTANCE AND ADVICE RELATING TO COMPLAINTS BY CONSUMERS AGAINST BUSINESSES; PROVIDING ONLINE INFORMATION DIRECTORIES AND DATABASES RELATING TO CONSUMER ADVICE; ADVERTISING BY TRANSMISSION OF ONLINE PUBLICITY FOR THIRD PARTIES THROUGH ELECTRONIC COMMUNICATIONS NETWORKS; PROMOTING THE GOODS AND SERVICES OF OTHERS OVER THE INTERNET; CONDUCTING, ORGANIZING OR ARRANGING EXHIBITIONS AND SHOWS FOR TRADE, COMMERCIAL OR ADVERTISING PURPOSES; ADVERTISING SERVICES BY MEANS OF TELEVISION SCREEN BASED TEXT; ADVERTISING SERVICES PROVIDED BY TELEVISION; PRODUCTION OF TELEVISION COMMERCIALS; PROVISION OF TELEVISION ADVERTISING FOR OTHERS; CONDUCTING, ORGANIZING OR ARRANGING SEMINARS OR CONFERENCES FOR TRADE, COMMERCIAL OR ADVERTISING PURPOSES (U.S. CLS. 100, 101 AND 102).

**CLASS 38—COMMUNICATION**

FOR ON-LINE COMMUNICATION SERVICES, NAMELY, TRANSFER OF INFORMATION AND MESSAGES, INCLUDING EMAIL; ON-LINE TELECOMMUNICATIONS SERVICES AND TRANSMISSIONS IN THE FORM OF TRANSFER OF INFORMATION AND MESSAGES INCLUDING E-MAIL; ON-LINE DOCUMENT DELIVERY VIA A GLOBAL COMPUTER NETWORK; PROVIDING ACCESS TO ON-LINE INFORMATION, DATABASES AND COMMUNICATION SERVICES; PROVIDING ACCESS TO ON-LINE MAGAZINES, BOOKS, MANUALS AND CATALOGS; PROVIDING ON-LINE ELECTRONIC BULLETIN BOARD SERVICES AND CHAT ROOMS; PROVIDING ACCESS TO ON-LINE BLOGS; PROVIDING ON-LINE FORUMS FOR TRANSMISSION OF MESSAGES AMONG COMPUTER USERS; PROVISION OF ON-LINE ACCESS TO DATABASES RELATING TO CONSUMER ADVICE; BROADCASTING OF INFORMATION BY TELEVISION; TELEVISION BROADCASTING; TELEVISION SCREEN-BASED TEXT TRANSMISSION SERVICES; TRANSMISSION OF COMPUTERIZED DATA BY MEANS OF TELEVISION; TRANSMISSION OF TELEVISION PROGRAMS; TELECONFERENCING SERVICES, NAMELY, ORGANIZING AND CONDUCTING ON-LINE MEETINGS AND INTERACTIVE DISCUSSIONS; PROVIDING AND MANAGING ON-LINE FORUMS FOR TRANSMISSION OF DISCUSSIONS AMONG COMPUTER USERS (U.S. CLS. 100, 101 AND 104).

**CLASS 41—EDUCATION AND ENTERTAINMENT**

FOR CONDUCTING, ORGANIZING AND ARRANGING LIVE AND ON-LINE EXHIBITIONS, SHOWS, SEMINARS OR CONFERENCES, OPEN TO THE PUBLIC, IN THE FIELD OF ADDRESSING AND PROMOTING ISSUES RELATED TO CULTURAL, ECONOMIC, ENVIRONMENTAL, GOVERNMENTAL AND SOCIAL CHANGE; DISTRIBUTION OF TELEVISION PROGRAMS; ENTERTAINMENT AND EDUCATION BY MEANS OF TELEVISION, NAMELY, PROGRAMS ADDRESSING AND PROMOTING ISSUES RELATED TO CULTURAL, ECONOMIC, ENVIRONMENTAL, GOVERNMENTAL AND SOCIAL CHANGE; NEWS AND INFORMATION PROGRAM SERVICES FOR TELEVISION; PRESENTATION OF TELEVISION PROGRAMS IN THE FIELD OF ADDRESSING AND PROMOTING ISSUES RELATED TO CULTURAL, ECONOMIC, ENVIRONMENTAL, GOVERNMENTAL AND SOCIAL CHANGE; PRODUCTION OF RADIO AND TELEVISION PROGRAMS; PROVISION OF INFORMATION RELATING TO TELEVISION PROGRAMS; SYNDICATION OF TELEVISION PROGRAMS (U.S. CLS. 100, 101 AND 107).

**CLASS 42—SCIENTIFIC AND COMPUTER SERVICES**

FOR CREATING ELECTRONICALLY STORED WEB PAGES FOR ON-LINE SERVICES AND THE INTERNET; HOSTING OF DIGITAL CONTENT, NAMELY, ONLINE JOURNALS, PERSONAL AND BUSINESS PROFILES, BUSINESS AND SOCIAL NETWORKING INFORMATION, INFORMATION RELATING TO CONSUMER ADVICE, CONSUMER COMPLAINTS, AND THE QUALITY OF GOODS AND SERVICES PROVIDED BY BUSINESSES; HOSTING AN INTERACTIVE WEBSITE THROUGH WHICH USERS CREATE, MANIPULATE AND SHARE INFORMATION, COMMENTS AND USER-GENERATED CONTENT; PROVIDING TEMPORARY USE OF ONLINE, NON-DOWNLOADABLE SOFTWARE THAT ENABLES USERS TO SHARE USER-GENERATED CONTENT WITH THIRD PARTIES VIA A GLOBAL COMPUTER NETWORK; PROVISION OF AN INTERNET PLATFORM FOR SOCIAL NETWORKING SERVICES (U.S. CLS. 100 AND 101).



**CLASS 45—PERSONAL AND LEGAL SERVICES**

FOR INTERNET BASED INTRODUCTION AND SOCIAL NETWORKING SERVICES; PROVIDING ONLINE INFORMATION DIRECTORIES AND DATABASES RELATING TO SOCIAL NETWORKING; ADVISORY SERVICES RELATING TO CONSUMERS RIGHTS; INFORMATION SERVICES RELATING TO CONSUMER RIGHTS (U.S. CLS. 100 AND 101).

BRIAN NEVILLE, EXAMINING ATTORNEY

SN 77-875,336. KLARÄLVDALENS DATAKONSULT AKTIEBOLAG, SE-683 21 HAGFORS, SWEDEN, FILED 11-18-2009.



PRIORITY CLAIMED UNDER SEC. 44(D) ON ERPN CMNTY TM OFC APPLICATION NO. 008409229, FILED 7-7-2009, REG. NO. 008409229, DATED 7-7-2009, EXPIRES 7-7-2019.

OWNER OF U.S. REG. NO. 3,135,223.

THE MARK CONSISTS OF A MISCELLANEOUS DESIGN OF A HALF TREE.

**CLASS 9—ELECTRICAL AND SCIENTIFIC APPARATUS**

FOR DATA PROCESSING APPARATUS, COMPUTERS, COMPUTER PERIPHERAL DEVICES; REGISTERED COMPUTER PROGRAMS FOR SOFTWARE DEVELOPERS, NAMELY, COMPUTER SOFTWARE DEVELOPMENT TOOLS FOR USE TO ALLOW REPORT GENERATING, CALENDARING, CHARTING AND GENERAL USER INTERACTION FUNCTIONALITIES IN THE DEVELOPMENT OF OTHER SOFTWARE PROGRAMS AND WHICH INCLUDES FILE SOFTWARE UPDATING, SOFTWARE TESTING, SYSTEM MONITORING, PROGRAMMING TOOLS, AND FOR USE IN INSERTING USER INTERFACE WIDGETS INTO SOFTWARE APPLICATIONS BY USING C++ CROSS-PLATFORM APPLICATION AND USER INTERFACE SOFTWARE FRAMEWORKS; COMPUTER HARDWARE (U.S. CLS. 21, 23, 26, 36 AND 38).

**CLASS 41—EDUCATION AND ENTERTAINMENT**

FOR EDUCATIONAL SERVICES, NAMELY, CLASSES AND SEMINARS IN THE FIELD OF COMPUTER SOFTWARE AND COMPUTER PROGRAMS, NAMELY, PROGRAMMING USING C++ CROSS-PLATFORM APPLICATION AND USER INTERFACE SOFTWARE FRAMEWORKS FOR DESKTOP, EMBEDDED AND MOBILE AND INDUSTRIAL COMPUTING SYSTEMS; EDUCATIONAL SERVICES, NAMELY, CLASSES AND SEMINARS IN THE FIELD OF TESTING OF SOFTWARE FOR DESKTOP, EMBEDDED AND MOBILE AND INDUSTRIAL COMPUTING SYSTEMS; COMPUTER EDUCATION TRAINING SERVICES (U.S. CLS. 100, 101 AND 107).

**CLASS 42—SCIENTIFIC AND COMPUTER SERVICES**

FOR COMPUTER PROGRAMMING, COMPUTER SYSTEMS ANALYSIS, CONSULTANCY IN THE FIELD OF COMPUTER SOFTWARE, NAMELY, MAINTENANCE, UPDATING AND DESIGN (U.S. CLS. 100 AND 101).

DANIEL CAPSHAW, EXAMINING ATTORNEY

SN 77-875,369. KLARÄLVDALENS DATAKONSULT AKTIEBOLAG, SE-683 21 HAGFORS, SWEDEN, FILED 11-18-2009.

OWNER OF ERPN CMNTY TM OFC REG. NO. 008409211, DATED 7-7-2009, EXPIRES 7-7-2019.

OWNER OF U.S. REG. NO. 3,135,223.

THE MARK CONSISTS OF THE STYLIZED LETTERS "KDAB".

**CLASS 9—ELECTRICAL AND SCIENTIFIC APPARATUS**

FOR DATA PROCESSING APPARATUS, COMPUTERS, COMPUTER PERIPHERAL DEVICES; REGISTERED COMPUTER PROGRAMS FOR SOFTWARE DEVELOPERS, NAMELY, COMPUTER SOFTWARE DEVELOPMENT TOOLS FOR USE TO ALLOW REPORT GENERATING, CALENDARING, CHARTING AND GENERAL USER INTERACTION FUNCTIONALITIES IN THE DEVELOPMENT OF OTHER SOFTWARE PROGRAMS AND WHICH INCLUDES FILE SOFTWARE UPDATING, SOFTWARE TESTING, SYSTEM MONITORING, PROGRAMMING TOOLS, AND FOR USE IN INSERTING USER INTERFACE WIDGETS INTO SOFTWARE APPLICATIONS BY USING C++ CROSS-PLATFORM APPLICATION AND USER INTERFACE SOFTWARE FRAMEWORKS; COMPUTER HARDWARE (U.S. CLS. 21, 23, 26, 36 AND 38).

**CLASS 41—EDUCATION AND ENTERTAINMENT**

FOR EDUCATIONAL SERVICES, NAMELY, CLASSES AND SEMINARS IN THE FIELD OF COMPUTER SOFTWARE AND COMPUTER PROGRAMS, NAMELY, PROGRAMMING USING C++ CROSS-PLATFORM APPLICATION AND USER INTERFACE SOFTWARE FRAMEWORKS FOR DESKTOP, EMBEDDED AND MOBILE AND INDUSTRIAL COMPUTING SYSTEMS; EDUCATIONAL SERVICES, NAMELY, CLASSES AND SEMINARS IN THE FIELD OF TESTING OF SOFTWARE FOR DESKTOP, EMBEDDED AND MOBILE AND INDUSTRIAL COMPUTING SYSTEMS; COMPUTER EDUCATION TRAINING SERVICES (U.S. CLS. 100, 101 AND 107).

**CLASS 42—SCIENTIFIC AND COMPUTER SERVICES**

FOR COMPUTER PROGRAMMING, COMPUTER SYSTEMS ANALYSIS, CONSULTANCY IN THE FIELD OF COMPUTER SOFTWARE, NAMELY, MAINTENANCE, UPDATING AND DESIGN (U.S. CLS. 100 AND 101).

DANIEL CAPSHAW, EXAMINING ATTORNEY

SN 77-876,383. KLARÄLVDALENS DATAKONSULT AKTIEBOLAG, SE-683 21 HAGFORS, SWEDEN, FILED 11-19-2009.

SN 77-876,682. RUGGEDCOM INC., CONCORD, CANADA, FILED 11-19-2009.



PRIORITY CLAIMED UNDER SEC. 44(D) ON ERPNTY TM OFC APPLICATION NO. 008409237, FILED 7-7-2009, REG. NO. 008409237, DATED 7-7-2009, EXPIRES 7-7-2019.

OWNER OF U.S. REG. NO. 3,135,223.  
THE MARK CONSISTS OF A MISCELLANEOUS DESIGN OF A HALF TREE AND A STYLIZED WORD FOR "KDAB".

#### **CLASS 9—ELECTRICAL AND SCIENTIFIC APPARATUS**

FOR DATA PROCESSING APPARATUS, COMPUTERS, COMPUTER PERIPHERAL DEVICES; REGISTERED COMPUTER PROGRAMS FOR SOFTWARE DEVELOPERS, NAMELY, COMPUTER SOFTWARE DEVELOPMENT TOOLS FOR USE TO ALLOW REPORT GENERATING, CALENDARING, CHARTING AND GENERAL USER INTERACTION FUNCTIONALITIES IN THE DEVELOPMENT OF OTHER SOFTWARE PROGRAMS AND WHICH INCLUDES FILE SOFTWARE UPDATING, SOFTWARE TESTING, SYSTEM MONITORING, PROGRAMMING TOOLS, AND FOR USE IN INSERTING USER INTERFACE WIDGETS INTO SOFTWARE APPLICATIONS BY USING C++ CROSS-PLATFORM APPLICATION AND USER INTERFACE SOFTWARE FRAMEWORKS; COMPUTER HARDWARE (U.S. CLS. 21, 23, 26, 36 AND 38).

#### **CLASS 41—EDUCATION AND ENTERTAINMENT**

FOR EDUCATIONAL SERVICES, NAMELY, CLASSES AND SEMINARS IN THE FIELD OF COMPUTER SOFTWARE AND COMPUTER PROGRAMS, NAMELY, PROGRAMMING USING C++ CROSS-PLATFORM APPLICATION AND USER INTERFACE SOFTWARE FRAMEWORKS FOR DESKTOP, EMBEDDED AND MOBILE AND INDUSTRIAL COMPUTING SYSTEMS; EDUCATIONAL SERVICES, NAMELY, CLASSES AND SEMINARS IN THE FIELD OF TESTING OF SOFTWARE FOR DESKTOP, EMBEDDED AND MOBILE AND INDUSTRIAL COMPUTING SYSTEMS; COMPUTER EDUCATION TRAINING SERVICES (U.S. CLS. 100, 101 AND 107).

#### **CLASS 42—SCIENTIFIC AND COMPUTER SERVICES**

FOR COMPUTER PROGRAMMING, COMPUTER SYSTEMS ANALYSIS, CONSULTANCY IN THE FIELD OF COMPUTER SOFTWARE, NAMELY, MAINTENANCE, UPDATING AND DESIGN (U.S. CLS. 100 AND 101).  
DANIEL CAPSHAW, EXAMINING ATTORNEY

## **RUGGEDMAX**

THE MARK CONSISTS OF STANDARD CHARACTERS WITHOUT CLAIM TO ANY PARTICULAR FONT, STYLE, SIZE, OR COLOR.

PRIORITY CLAIMED UNDER SEC. 44(D) ON CANADA APPLICATION NO. 1440691, FILED 6-8-2009, REG. NO. TMA782133, DATED 11-10-2010, EXPIRES 11-10-2025.

OWNER OF U.S. REG. NOS. 2,861,221, 3,342,227 AND 3,350,474.

#### **CLASS 9—ELECTRICAL AND SCIENTIFIC APPARATUS**

FOR COMPUTER HARDWARE; COMPUTER SOFTWARE, NAMELY, AN EMBEDDED OPERATING SYSTEM FOR COMPUTERS, MANAGED ETHERNET SWITCHES AND/OR SERIAL DEVICE SERVERS FORMING A NETWORK; COMPUTER SOFTWARE, NAMELY, AN OPERATING SYSTEM FOR COMPUTERS AND/OR MANAGED ETHERNET SWITCHES AND/OR SERIAL DEVICE SERVERS CONNECTED TO A NETWORK; COMPUTER SOFTWARE FOR VISUALIZING A COMPUTER NETWORK; COMPUTER SOFTWARE FOR DISCOVERING DEVICES CONNECTED TO A COMPUTER NETWORK; COMMUNICATION ROUTERS, SWITCHES, COMPUTERS AND MODEMS; GATEWAY ROUTERS IN THE NATURE OF COMPUTER CONTROL HARDWARE; FIBER OPTIC CABLES, CONNECTORS AND FILTERS; FIBER OPTICAL NETWORKS COMPRISED PRIMARILY OF HUBS, COMPUTER SWITCHES AND FIBER-TO-ELECTRICAL MEDIA CONVERTERS, COMMUNICATION HUBS, COMMUNICATION ROUTERS AND SWITCHES HAVING MIXED FIBER OPTICAL AND ELECTRICAL MEDIA PORTS; COMPUTER NETWORK HUBS, COMPUTER SWITCHES AND ROUTERS HAVING FIBER OPTICAL PORTS; COMPUTER HUBS, ROUTERS AND COMPUTER SWITCHES HAVING MIXED FIBER OPTICAL AND ELECTRICAL MEDIA PORTS; FIBER OPTICAL ETHERNET NETWORKS COMPRISED OF COMMUNICATION HUBS, SWITCHES, FIBER-TO-ELECTRICAL MEDIA CONVERTERS, SERIAL TO ETHERNET SERVERS, COMMUNICATION HUBS, COMMUNICATION ROUTERS, COMPUTER HUBS, COMPUTER NETWORK ROUTERS, COMPUTER SWITCHES AND SERIAL TO ETHERNET SERVERS HAVING MIXED FIBER OPTIC TO ELECTRICAL MEDIA PORTS; COMPUTER NETWORK HUBS, SWITCHES AND ROUTERS HAVING OPTICAL PORTS; COMPUTER HUBS, ROUTERS, SWITCHES, SERIAL TO ETHERNET COMPUTER SERVERS AND SERIAL DEVICE COMPUTER SERVERS HAVING MIXED FIBER OPTIC AND COPPER PORTS; VIDEO ENCODERS; FIBER OPTIC TO CABLE CONVERTERS; FIBER OPTICAL TO ELECTRICAL MEDIA CONVERTERS; SERIAL TO ETHERNET GATEWAY ROUTERS IN THE NATURE OF COMPUTER CONTROL HARDWARE; SERIAL DEVICE COMPUTER SERVERS (U.S. CLS. 21, 23, 26, 36 AND 38).

#### **CLASS 35—ADVERTISING AND BUSINESS**

FOR ON-LINE RETAIL STORE SERVICES FEATURING FIBER OPTICAL NETWORKS, ROUTERS, SWITCHES, GATEWAYS, MODEMS, FIBER OPTIC CABLES, CONNECTORS AND FILTERS, FIBER OPTICAL NETWORKS, FIBER OPTICAL ETHERNET NETWORKS, COMPUTER HARDWARE, COMPUTER SOFTWARE AND COMMUNICATION EQUIPMENT; COMPUTERIZED ON-LINE RETAIL STORE SERVICES IN THE FIELD OF FIBER OPTICAL NETWORKS, ROUTERS, SWITCHES, GATEWAYS, MODEMS, FIBER OPTIC CABLES, CONNECTORS AND FILTERS, FIBER OPTICAL NETWORKS, FIBER OPTICAL ETHERNET NETWORKS, COMPUTER HARDWARE, COMPUTER SOFTWARE AND COMMUNICATION EQUIPMENT; ONLINE RETAIL STORE FEATURING COMMUNICA-

TION ROUTERS, SWITCHES, GATEWAYS, COMPUTERS, MODEMS, FIBER OPTIC CABLES, CONNECTORS AND FILTERS, FIBER OPTICAL NETWORKS, FIBER OPTICAL ETHERNET NETWORKS; RETAIL STORE SERVICES FEATURING FIBER OPTICAL NETWORKS, ROUTERS, SWITCHES, GATEWAYS, MODEMS, FIBER OPTIC CABLES, CONNECTORS AND FILTERS, FIBER OPTICAL NETWORKS, FIBER OPTICAL ETHERNET NETWORKS, COMPUTER HARDWARE, COMPUTER SOFTWARE AND COMMUNICATION EQUIPMENT; ARRANGING AND CONDUCTING COMMERCIAL EXHIBITIONS OF FIBER OPTICAL NETWORKS, COMPUTER HARDWARE, COMPUTER SOFTWARE AND COMMUNICATIONS EQUIPMENT FOR RETAIL PURPOSE ON COMMUNICATION MEDIA; PROVIDING ONLINE BUSINESS INFORMATION SERVICES IN THE FIELD OF THE COMMERCIAL USES OF FIBER OPTICAL NETWORKS, COMPUTER HARDWARE, COMPUTER SOFTWARE AND COMMUNICATIONS EQUIPMENT; TELECOMMUNICATIONS NETWORK MANAGEMENT SERVICES, NAMELY, THE OPERATION AND ADMINISTRATION OF TELECOMMUNICATION SYSTEMS AND NETWORKS FOR OTHERS (U.S. CLS. 100, 101 AND 102).

#### **CLASS 42—SCIENTIFIC AND COMPUTER SERVICES**

FOR TECHNICAL SUPPORT, NAMELY, MONITORING OF NETWORK SYSTEMS; COMPUTER DIAGNOSTIC SERVICES FOR NETWORK SYSTEM; COMPUTER NETWORK DESIGN FOR OTHERS; COMPUTER NETWORK CONSULTING SERVICES; DESIGN, DEPLOYMENT AND MANAGEMENT OF COMPUTER NETWORKS FOR OTHERS; COMPUTER COMMUNICATION NETWORK CONSULTING SERVICES; MONITORING OF COMPUTER NETWORK SYSTEMS FOR SYSTEM FAILURE OR DECREASE IN PERFORMANCE; MONITORING OF THE PERFORMANCE AND PHYSICAL STRUCTURE OF A COMPUTER NETWORK (U.S. CLS. 100 AND 101).

#### **CLASS 45—PERSONAL AND LEGAL SERVICES**

FOR MONITORING OF COMPUTER NETWORK SYSTEMS FOR SECURITY PURPOSES (U.S. CLS. 100 AND 101).

JOHN DALIER, EXAMINING ATTORNEY

SN 77-876,897. VELOCITYSHARES, LLC, NEW CANAAN, CT. FILED 11-19-2009.

## **GEARED FOR TRADERS**

THE MARK CONSISTS OF STANDARD CHARACTERS WITHOUT CLAIM TO ANY PARTICULAR FONT, STYLE, SIZE, OR COLOR.

NO CLAIM IS MADE TO THE EXCLUSIVE RIGHT TO USE "TRADERS", APART FROM THE MARK AS SHOWN.

#### **CLASS 35—ADVERTISING AND BUSINESS**

FOR PROVIDING FINANCIAL INDICES BASED ON SELECTED GROUPS OF SECURITIES; ADVERTISING AND MARKETING SERVICES FEATURING INDEXES, INDEX FUNDS, EXCHANGE TRADED FUNDS, EXCHANGE TRADED NOTES, INVESTMENT SECURITIES, COMMODITY POOLS, FINANCIAL FUTURES CONTRACTS, OPTIONS, STRUCTURED NOTES, AND DERIVATIVES; MARKETING OF INVESTMENT VEHICLES ALSO KNOWN AS INVESTMENT COMPANIES, NAMELY, OPEN-END INVESTMENT COMPANIES, MUTUAL FUNDS AND EXCHANGE TRADED FUNDS, EXCHANGE TRADED NOTES, CLOSED-END INVESTMENT COMPANIES, COMMODITY POOLS, AND BUSINESS DEVELOPMENT COMPANIES (U.S. CLS. 100, 101 AND 102).

#### **CLASS 36—INSURANCE AND FINANCIAL**

FOR FINANCIAL SERVICES IN THE NATURE OF INVESTMENT SECURITIES; BROKERAGE OF SHARES AND OTHER SECURITIES; FINANCIAL SERVICES, NAMELY, SPONSORING, OFFERING, BROKERING, MANAGING AND ADMINISTERING INDEX FUNDS, EXCHANGE TRADED FUNDS, EXCHANGE TRADED NOTES, INVESTMENT SECURITIES, COMMODITY POOLS, FINANCIAL FUTURES CONTRACTS, OPTIONS, STRUCTURED NOTES, AND DERIVATIVES; FINANCIAL SERVICES, NAMELY, SPONSORING, OFFERING, BROKERING, MANAGING AND ADMINISTERING INVESTMENT VEHICLES ALSO KNOWN AS INVESTMENT COMPANIES, NAMELY, OPEN-END INVESTMENT COMPANIES, MUTUAL FUNDS AND EXCHANGE TRADED FUNDS, EXCHANGE TRADED NOTES, CLOSED-END INVESTMENT COMPANIES, COMMODITY POOLS, AND BUSINESS DEVELOPMENT COMPANIES (U.S. CLS. 100, 101 AND 102).

HEATHER BIDDULPH, EXAMINING ATTORNEY

SN 77-877,369. FAIRCHILD KOREA SEMICONDUCTOR LTD., BUCHEON-SI, GYEONGGI-DO, REPUBLIC OF KOREA, FILED 11-20-2009.

## **Auto-SPM**

THE MARK CONSISTS OF STANDARD CHARACTERS WITHOUT CLAIM TO ANY PARTICULAR FONT, STYLE, SIZE, OR COLOR.

OWNER OF U.S. REG. NO. 2,828,934.

#### **CLASS 7—MACHINERY**

FOR VEHICLE ENGINE PARTS, NAMELY, SEMICONDUCTOR DEVICES, COMPUTER CHIPS AND INTEGRATED CIRCUITS SOLD AS AN INTEGRAL COMPONENT OF VEHICLE ENGINES (U.S. CLS. 13, 19, 21, 23, 31, 34 AND 35).

#### **CLASS 9—ELECTRICAL AND SCIENTIFIC APPARATUS**

FOR SEMICONDUCTOR DEVICES; COMPUTER CHIPS; INTEGRATED CIRCUITS (U.S. CLS. 21, 23, 26, 36 AND 38).

#### **CLASS 12—VEHICLES**

FOR ELECTRONIC AND ELECTRIC PARTS FOR VEHICLES, NAMELY, SEMICONDUCTOR DEVICES, COMPUTER CHIPS AND INTEGRATED CIRCUITS SOLD AS AN INTEGRAL COMPONENT OF LAND VEHICLES (U.S. CLS. 19, 21, 23, 31, 35 AND 44).

MAYUR VAGHANI, EXAMINING ATTORNEY

SN 77-879,039. TRUE VALUE COMPANY, CHICAGO, IL.  
FILED 11-23-2009.

## MASTER PLUMBER

THE MARK CONSISTS OF STANDARD CHARACTERS WITHOUT CLAIM TO ANY PARTICULAR FONT, STYLE, SIZE, OR COLOR.

OWNER OF U.S. REG. NOS. 751,518, 1,432,602 AND OTHERS.

### CLASS 3—COSMETICS AND CLEANING PREPARATIONS

FOR SANDPAPER, NAMELY, PLUMBER'S ABRASIVE SAND CLOTH USED FOR CLEANING, POLISHING, AND FOR PREPARATION OF JOINTS FOR SOLDERING (U.S. CLS. 1, 4, 6, 50, 51 AND 52).

FIRST USE 7-1-2009; IN COMMERCE 7-1-2009.

### CLASS 4—LUBRICANTS AND FUELS

FOR LUBRICANT FOR FAUCETS, NAMELY, SILICONE GREASE (U.S. CLS. 1, 6 AND 15).

FIRST USE 7-1-2009; IN COMMERCE 7-1-2009.

### CLASS 6—METAL GOODS

FOR DEEP FLANGES MADE OF METAL; SHALLOW PIPE COVERS WITH A CHROME METAL FINISH; HARDWARE MOUNTING SYSTEM COMPRISED OF METAL BRACKETS FOR MOUNTING SHOWER HEADS, HANDHELD SHOWER HEADS, SHOWER ARMS, AND SHOWER SWIVEL CONNECTORS (U.S. CLS. 2, 12, 13, 14, 23, 25 AND 50).

FIRST USE 7-1-2009; IN COMMERCE 7-1-2009.

### CLASS 7—MACHINERY

FOR PUMP CONTROL VALVES, NAMELY, SUMP PUMP CHECK VALVES; ELECTRIC PUMPS, NAMELY, NON-EJECTOR SEWAGE PUMPS, EFFLUENT PUMPS, AND SEWAGE EJECTOR PUMPS; ELECTRIC PUMP SYSTEM COMPRISED OF A SUMP PUMP, TEN-GALLON STORAGE TANK, CHECK VALVE, GROMMETS, AND FITTINGS, FOR USE UNDER LAUNDRY TUBS, WET BARS, AIR CONDITIONER DRAINING, SINK DRAINING, OR TUB DRAINING (U.S. CLS. 13, 19, 21, 23, 31, 34 AND 35).

FIRST USE 7-1-2009; IN COMMERCE 7-1-2009.

### CLASS 8—HAND TOOLS

FOR HAND TOOLS, NAMELY, RIGID AND ROD HAND BENDERS FOR USE ON PIPES; HAND TOOLS, NAMELY, LEVER-STYLE TUBE BENDERS; HAND TOOLS, NAMELY, STAINLESS STEEL CABLE SAWS FOR CUTTING THROUGH PLASTIC PIPE; HAND-OPERATED DRILL PUMPS (U.S. CLS. 23, 28 AND 44).

FIRST USE 7-1-2009; IN COMMERCE 7-1-2009.

### CLASS 9—ELECTRICAL AND SCIENTIFIC APPARATUS

FOR REPLACEMENT ELECTRIC SWITCHES FOR COLUMN SUMP PUMP MACHINES; GAS LEAK DETECTORS IN LIQUID FORM; ELECTRIC SWITCHES, NAMELY, TETHERED UNIVERSAL FLOAT SWITCHES FOR SUMP PUMPS AND SUBMERSIBLE VERTICAL PUMP SWITCHES FOR SUMP PUMPS (U.S. CLS. 21, 23, 26, 36 AND 38).

FIRST USE 7-1-2009; IN COMMERCE 7-1-2009.

### CLASS 11—ENVIRONMENTAL CONTROL APPARATUS

FOR PLUMBING FIXTURES AND FITTINGS, NAMELY, SEWAGE CHECK VALVES, CHROME-PLATED METAL CONNECTORS FOR SHOWER SWIVELS, MANUALLY-OPERATED CHROME SHOWER FLOW VALVES, FAUCET STEMS, CHROME-PLATED COMPRESSION FITTINGS CONSISTING OF NUTS AND SLEEVES, CHROME-PLATED STRAIGHT COMPRESSION FITTINGS, CHROME-PLATED COMPRESSION NUTS AND SLEEVES, CHROME-PLATED ANGLED COMPRESSION FITTINGS, FAUCET ADAPTERS, SNAP-ON STAINLESS STEEL DRAIN COVERS, TOP ASSEMBLY ANTI-SIPHON FILL VALVE REPLACEMENT CAPS, PLASTIC FLUSH VALVE WITH RUBBER FLAPPERS, AND FLUSH VALVES IN THE NATURE OF HANDLE ASSEMBLIES MADE OF METAL; PLUMBING FIXTURES, NAMELY, SINK SPRAY HOSE GUIDE WITH PLASTIC CHROME FINISH; CHROME OR POWDER-COATED STEEL SINK HOLE COVERS WITH BOLTS AND WING NUTS FOR INSTALLATION; PLUMBING FIXTURES, NAMELY, TOILET FILL VALVE REPAIR KIT CONSISTING OF PLUNGER WASHERS AND THUMB SCREWS; PLUMBING FITTINGS, NAMELY, TOILET FILL VALVE REPAIR KIT FOR REPLACING BALLCOCK ASSEMBLIES; PLUMBING FITTINGS, NAMELY, ANTI-SIPHON TOILET FILL VALVES; PLUMBING FIXTURES, NAMELY, TOILET FILL VALVE REPAIR KITS CONSISTING OF A COMBINATION OF O-RINGS OR DIAPHRAGMS, PLASTIC PLUNGER ASSEMBLIES, PLASTIC SEATS, AND SCREWS; PLUMBING FIXTURES, NAMELY, FLUSH VALVE SEALS MADE OF RUBBER; PLUMBING FITTINGS, NAMELY, STAINLESS STEEL TOILET FLAPPER CHAINS WITH HOOKS; PLUMBING FITTINGS, NAMELY, PIPE STRAPPINGS MADE OF COPPER AND STEEL; PLUMBING FIXTURES, NAMELY, SHOWER ARM BALL ADAPTERS; PLUMBING FIXTURES, NAMELY, RELIEF VALVES MADE OF PLASTIC; PLUMBING FIXTURES, NAMELY, WATER SAVER VALVE ASSEMBLIES FOR SIPHON JET TOILETS AND WATER CLOSETS; PLUMBING SUPPLIES, NAMELY, SNAP-IN SINK HOLE COVERS MADE OF CHROME; CHROME NUT KITS FOR PLUMBING PURPOSES CONSISTING OF SLIP JOINT NUTS, WASHERS, AND BRASS FRICTION RINGS; FAUCET SHANK NUT KIT FOR PLUMBING PURPOSES CONSISTING OF METAL FAUCET SHANK NUT, CONE WASHER, AND BRASS FRICTION RING; TOILET TANK REPAIR KITS COMPRISED OF FILL VALVES, REFILL TUBES, CLIPS, FLOATS, FLAPPERS, FLOAT RODS, CHAINS, LOCK NUTS, AND COUPLING NUTS; WATER SAVER TOILET REPAIR KITS COMPRISED OF ANTI-SIPHON FILL VALVES, ADJUSTABLE WATER SAVER FLAPPERS, FLOATS, FLOAT RODS, REFILL TUBES, CONE WASHERS, LOCK NUTS, AND COUPLING NUTS; TOILET REPAIR KITS COMPRISED OF PLASTIC BULLOCK NUTS, CONE WASHERS, AND BRASS RINGS FOR CONNECTING THE WATER SUPPLY LINE TO THE TANK; PLUMBING FIXTURES IN THE NATURE OF TOILET FLAPPERS, NAMELY, REPLACEMENT FLUSH VALVE ACTUATOR WITH METAL CHAINS; PLUMBING FIXTURES IN THE NATURE OF TOILET FLUSH VALVE AND ACTUATING UNITS COMPRISED OF METAL CHAINS, METAL Y HOOKS, RUBBER SNAP ON SEAT DISCS, AND RUBBER WASHERS TO CONNECT TANK TO BOWL; METAL LOG LIGHTER KEYS, NAMELY, DEVICES FOR CONTROLLING GAS DELIVERY SYSTEMS IN GAS FIREPLACES; PLUMBING FIXTURES, NAMELY, SHOWER ARMS AND ADJUSTABLE SHOWER ARMS MADE OF CHROME OR BRASS; PLUMBING FIXTURES IN THE NATURE OF TOILET/URINAL TOP FILL VALVE ASSEMBLY MADE OF PLASTIC; PLUMBING FIXTURES IN THE NATURE OF SHOWER COUPLINGS WITH MOUNTING ARMS, USED FOR MOUNTING HANDHELD SHOWER HEADS, SHOWER HEADS, SHOWER ARMS, AND SHOWER SWIVEL CONNECTORS (U.S. CLS. 13, 21, 23, 31 AND 34).

FIRST USE 7-1-2009; IN COMMERCE 7-1-2009.

**CLASS 17—RUBBER GOODS**

FOR OUTDOOR FAUCET PROTECTORS, NAMELY, FOAM INSULATION FOR OUTDOOR FAUCETS; PIPE PLUG KITS FOR USE IN PLUMBING CONSISTING OF SEALING PLUGS MADE PRIMARILY FROM RUBBER; WASHERS OF RUBBER FOR USE AS FLUSH VALVE DISCS FOR PLUMBING USES; FLUSH VALVE SHANK WASHERS OF RUBBER FOR PLUMBING PURPOSES; SOLDERING SHIELDS, NAMELY, FIBERGLASS SHEETS USED TO COVER AND PROTECT OBJECTS FROM HEAT WHILE SOLDERING; SUMP PUMP ACCESSORIES, NAMELY, NONMETAL GAS SUCTION AND DISCHARGE HOSES FOR USE WITH ENGINE DRIVEN SUMP PUMPS (U.S. CLS. 1, 5, 12, 13, 35 AND 50).

FIRST USE 7-1-2009; IN COMMERCE 7-1-2009.

**CLASS 21—HOUSEWARES AND GLASS**

FOR WIRE BRUSHES, NOT BEING MACHINE PARTS, FOR USE AS TUBE CLEANING BRUSHES FOR CLEANING THE INSIDE OR OUTSIDE OF TUBES; CHROME-FINISH LIQUID SOAP DISPENSER (U.S. CLS. 2, 13, 23, 29, 30, 33, 40 AND 50).

FIRST USE 7-1-2009; IN COMMERCE 7-1-2009.  
CORY BOONE, EXAMINING ATTORNEY

SN 77-880,532. MITSUBISHI CATERPILLAR FORKLIFT AMERICA INC., HOUSTON, TX. FILED 11-25-2009.

# PROSHIFT

THE MARK CONSISTS OF STANDARD CHARACTERS WITHOUT CLAIM TO ANY PARTICULAR FONT, STYLE, SIZE, OR COLOR.

**CLASS 9—ELECTRICAL AND SCIENTIFIC APPARATUS**

FOR MICROPROCESSORS FOR TRANSMISSIONS FOR LAND VEHICLES (U.S. CLS. 21, 23, 26, 36 AND 38).

**CLASS 12—VEHICLES**

FOR TRANSMISSION MECHANISMS FOR LAND VEHICLES (U.S. CLS. 19, 21, 23, 31, 35 AND 44).  
STEVEN R. FINE, EXAMINING ATTORNEY

SN 77-884,385. LES INDUSTRIES STE-ANNE-DE-LA-ROCHELLE INC., STE-ANNE-DE-LA-ROCHELLE, CANADA, FILED 12-2-2009.

# ECOTERRA

THE MARK CONSISTS OF STANDARD CHARACTERS WITHOUT CLAIM TO ANY PARTICULAR FONT, STYLE, SIZE, OR COLOR.

OWNER OF CANADA REG. NO. TMA732,391, DATED 1-14-2009, EXPIRES 1-14-2024.

**CLASS 37—CONSTRUCTION AND REPAIR**

FOR CUSTOM CONSTRUCTION OF HOMES; CONSTRUCTION OF HOUSES (U.S. CLS. 100, 103 AND 106).

**CLASS 40—MATERIAL TREATMENT**

FOR CUSTOM MANUFACTURE OF STRUCTURAL COMPONENTS OF HOUSES (U.S. CLS. 100, 103 AND 106).

APRIL HESIK, EXAMINING ATTORNEY

SN 77-885,627. ETERA CONSULTING, LLC, AKRON, OH. FILED 12-3-2009.

## EARLY INFORMATION ASSESSMENT

THE MARK CONSISTS OF STANDARD CHARACTERS WITHOUT CLAIM TO ANY PARTICULAR FONT, STYLE, SIZE, OR COLOR.

NO CLAIM IS MADE TO THE EXCLUSIVE RIGHT TO USE "INFORMATION ASSESSMENT", APART FROM THE MARK AS SHOWN.

**CLASS 42—SCIENTIFIC AND COMPUTER SERVICES**

FOR CONVERSION OF DATA OR DOCUMENTS FROM PHYSICAL TO ELECTRONIC MEDIA; DOCUMENT DATA TRANSFER FROM ONE COMPUTER FORMAT TO ANOTHER; ELECTRONIC LEGAL DISCOVERY CONSULTING SERVICES (U.S. CLS. 100 AND 101).

**CLASS 45—PERSONAL AND LEGAL SERVICES**

FOR LITIGATION SUPPORT SERVICES (U.S. CLS. 100 AND 101).

DAVID MILLER, EXAMINING ATTORNEY

SN 77-888,843. MEANINGFUL FOOD LLC, MIAMI, FL. FILED 12-8-2009.

# meaningful.

THE MARK CONSISTS OF THE WORD "MEANINGFUL" IN ALL LOWER-CASE LETTERS IN A PARTICULAR FONT WITH A PERIOD FOLLOWING IT.

**CLASS 5—PHARMACEUTICALS**

FOR ENERGY BOOSTING BARS FOR USE AS A MEAL SUBSTITUTE; COUGH DROPS (U.S. CLS. 6, 18, 44, 46, 51 AND 52).

**CLASS 29—MEATS AND PROCESSED FOODS**

FOR FRUIT PUREES; FRUIT PUREES, FRUIT JUICES, AND NON-ALCOHOLIC FRUIT EXTRACTS USED AS INGREDIENTS OF FOODS (U.S. CL. 46).

**CLASS 30—STAPLE FOODS**

FOR BREAKFAST CEREALS; CEREAL-BASED ENERGY BARS NOT FOR USE AS A MEAL REPLACEMENT; ICE CREAM; SORBET; CHEWING GUM; CANDY; FROZEN CONFECTIONS (U.S. CL. 46).

**CLASS 32—LIGHT BEVERAGES**

FOR FRUIT JUICES; NON-ALCOHOLIC FRUIT EXTRACTS USED IN THE PREPARATION OF ALCOHOLIC AND NON-ALCOHOLIC BEVERAGES; FRUIT JUICES AND FRUIT PUREES USED AS INGREDIENTS OF ALCOHOLIC AND NON-ALCOHOLIC BEVERAGES; FRUIT FLAVORED NON-ALCOHOLIC BEVERAGES; FLAVORED WATER; SPARKLING FLAVORED WATER; ENERGY DRINKS; ENERGY DRINKS IN THE FORM OF SINGLE SHOTS (U.S. CLS. 45, 46 AND 48).

**CLASS 33—WINES AND SPIRITS**

FOR ALCOHOLIC ENERGY DRINKS; FRUIT FLAVORED ALCOHOLIC SPIRITS; ALCOHOLIC FRUIT EXTRACTS; ALCOHOLIC FRUIT JUICES (U.S. CLS. 47 AND 49).

DAVID TAYLOR, EXAMINING ATTORNEY

SN 77-897,755. BLOOM, AKIVAH, BROOKLYN, NY. FILED 12-20-2009.



THE MARK CONSISTS OF THE STYLIZED WORDING "BACKSEAT BETTE". THE LETTER "T" IN THE WORD "BACKSEAT" CONSISTS OF TWO HORNS AND A HALO. THE MARK ALSO CONSISTS OF A CAR WITH A MAN, BOY AND GIRL IN IT PLACED ABOVE THE STYLIZED LETTERS "BACKS" IN THE WORD "BACKSEAT". UNDERNEATH THE STYLIZED LETTER "B" IN "BACKSEAT" AND BESIDE THE STYLIZED LETTER "B" IN THE WORD "BETTE" THERE ARE THREE STARS. IN THE STYLIZED LETTER "B" IN THE WORD "BETTE" THERE IS A HEART WITH TWO BONES IN THEM. BESIDE THE STYLIZED LETTER "E" IN THE WORD "BETTE" AND ON AND/OR UNDERNEATH THE STYLIZED LETTERS "EAT" IN THE WORD "BACKSEAT" THERE IS A GIRL MAKING A COMMENT IN A WORD BUBBLE. THE WORDING IN THE BUBBLE IS "I DID IT, BUT I'M BLAMING YOU!".

**CLASS 16—PAPER GOODS AND PRINTED MATTER**

FOR ADDRESS BOOKS, ADDRESS LABELS, ADHESIVE NOTE PADS, ALBUMS FOR STICKERS, ANIMATION CELLS, ANNIVERSARY BOOKS, ANNOUNCEMENT CARDS, APPLIQUES IN THE FORM OF DECALS, APPOINTMENT BOOKS, ART ETCHINGS, ART PADS, ART PAPER, ART PICTURES, ART PRINTS, ARTISTS' BRUSHES, ARTISTS' PASTELS, ARTISTS' PENCILS, ARTISTS' PENS, ARTS AND CRAFTS CLAY KITS, ARTS AND CRAFTS PAINT KITS, AUTOGRAPH BOOKS, BABIES DIAPERS OF PAPER, BABY BOOKS, BALL PENS, BALL POINT PENS, BANK CHECKS, BANNERS OF PAPER, BINDERS, BLACKBOARD CHALK ERASERS, BLACKBOARDS, BLANK CARDS, BLANK NOTE CARDS, BLANK OR PARTIALLY PRINTED POST CARDS, BOND PAPER, BOOK BINDINGS, BOOK COVERS, BOOK HOLDERS, BOOK

PLATES, BOOKENDS, BOOKLETS DEALING WITH CHARACTER BIOGRAPHY AND PET CARE, BOOKMARKS, BOOK-COVER PAPER, BOXES OF PAPER OR CARDBOARD, BUMPER STICKERS, BURP PADS OF PAPER, CALENDAR DESK PADS, CALENDAR DESK STANDS, CALENDAR STANDS, CALENDARS, CARDS, NAMELY, STATIONERY CARDS, CARICATURES, CARTOON PRINTS, CARTOON STRIPS, CHALK, CHALK BOARDS FOR SCHOOL AND HOME USE, CHALK ERASERS, CHARCOAL PENCILS, CHECK BOOKS, CHECKBOOK COVERS, CHECKBOOK HOLDERS, CHILDREN'S ACTIVITY BOOKS, CHILDREN'S BOOKS, CHILDREN'S STORYBOOKS, COASTERS MADE OF PAPER, COLOR PENCILS, COLOR PRINTS, COLOR BOARD, NAMELY, COLORED PAPERBOARD, COLORING BOOKS, COMIC BOOKS, COMIC STRIPS, COMMEMORATIVE STAMP SHEETS, COMPOSITION BOOKS, COMPUTER GAME INSTRUCTION MANUALS, COMPUTER PAPER, COMPUTER PROGRAM MANUALS FOR USE IN CONNECTION WITH SCREEN SAVERS, EDUCATIONAL ACTIVITIES AND COMPUTER ART, CONSTRUCTION PAPER, COOK BOOKS, COSMETIC PENCIL SHARPENERS, CRAYONS, DAILY PLANNERS, DATE BOOKS, DAY PLANNERS, DECALS, DECORATIONS FOR PENCILS, DECORATIVE PAPER CENTERPIECES, DECORATIVE PENCIL-TOP ORNAMENTS, DECORATIVE STICKERS FOR HELMETS, DESK BASKETS FOR DESK ACCESSORIES, DESK CALENDARS, DESK PADS, DESK SETS, DESK STANDS AND HOLDERS FOR PENS, PENCILS, AND INK, DESK TOP ORGANIZERS, DESK TOP PLANNERS, DIARIES, DICTIONARIES, DISPOSABLE DIAPERS, DISPOSABLE NAPKINS, DISPOSABLE PADS FOR DIAPER CHANGING, DISPOSABLE TRAINING PANTS, DISPOSABLE WIPES NOT IMPREGNATED WITH CHEMICALS OR COMPOUNDS, DRAFTING RULERS, DRAWING BOARDS, DRAWING PADS, DRAWING PAPER, DRAWING RULERS, DRAWINGS, EASELS, EDUCATIONAL BOOKS DEALING WITH EARLY CHILDHOOD AND PET CARE, ELECTRONIC PENCILS SHARPENERS, EMBROIDERY DESIGN PATTERNS PRINTED ON PAPER, ENCYCLOPEDIAS, ENGRAVING PLATES, ENGRAVINGS, ENGRAVINGS AND THEIR REPRODUCTIONS, ENVELOPE PAPER, ENVELOPES, ERASERS, ETCHINGS, EVENT ALBUMS, EXERCISE BOOKS, FABRIC GIFT BAGS, FACIAL TISSUE, FELT PENS, FELT TIPS MARKERS, FLASH CARDS, FOLDERS, FOOD WRAPPERS, GIFT CARDS, GIFT WRAPPING PAPER, GLUE FOR STATIONERY OR HOUSEHOLD USE, GLUE STICKS FOR STATIONERY OR HOUSEHOLD USE, GRAPHIC ART REPRODUCTIONS, GRAPHIC NOVELS, GREETING CARDS, GUIDE BOOKS DEALING WITH PET CARE, HAND TOWELS OF PAPER, ILLUSTRATED NOTE PADS, ILLUSTRATION BOARDS, ILLUSTRATION PAPER, ILLUSTRATIONS, IMPRESSION STAMPS, INK STAMPS, INK PADS, INVITATION CARDS, LETTER CLIPS, LITHOGRAPHIC PRINTS, LITHOGRAPHS, LOOSE LEAF BINDERS, LOOSE LEAF PAPER, LOOSE-LEAF PADS, LUNCH BAGS, MAGAZINES FOR YOUNG GIRLS AND DOG CARE, MAGNETIC BOARDS, MARKERS, MECHANICAL PENCILS, MEMO BLOCKS, MEMO PADS, MEMORY BOOKS IN THE NATURE OF PHOTO ALBUMS, MODELING CLAY FOR CHILDREN, MOLDS FOR MODELING CLAY, MURALS, MUSICAL GREETING CARDS, NAPKIN PAPER, NEWSLETTER FOR YOUNG GIRLS AND DOG CARE, NEWSPAPER CARTOONS, NEWSPAPER COMIC STRIPS, NEWSPAPERS, NOTEBOOKS, NOTEBOOK DIVIDERS, OCCASION CARDS, OIL PASTELS, PLASTIC BAGS FOR PACKAGING, PAINT BRUSHES, PAINT TRAYS, PAINTING PALETTES, PAINTING SETS FOR CHILDREN, PAINTINGS, PAINTINGS AND THEIR REPRODUCTIONS, PAPER, NAMELY, PRINTING PAPER; PAPER BABY BIBS, PAPER BAGS, PAPER BANNERS, PAPER CAKE DECORATIONS, PAPER CLIP HOLDERS, PAPER CLIPS, PAPER DIAPERS, PAPER DOILIES, PAPER ENVELOPES FOR PACKAGING, PAPER GIFT BAGS, PAPER GIFT WRAP BOWS, PAPER GIFT WRAPPING RIBBONS, PAPER HAND TOWELS, PAPER IDENTIFICATION TAGS, PAPER ILLUSTRATION BOARDS, PAPER LABELS, PAPER MACHE FIGURINES, PAPER NAPKINS, PAPER PARTY BAGS, PAPER PARTY DECORATIONS, PAPER PARTY FAVORS, PAPER STATIONERY, PAPER TABLE LINENS, PAPER TAGS, PAPER TOWELS, PAPERWEIGHTS, PASTEL CRAYONS, PASTELS, PATTERNS FOR MAKING CLOTHING AND FURNITURE, PENS AND PENCILS CASES AND BOXES, PEN RESTS, PENCIL BOXES, PENCIL OR PEN BOXES, STATIONERY

PENCIL ORNAMENTS, PENCIL SHARPENERS, PENCILS, PENHOLDERS, PENS, PERSONAL ORGANIZERS, PHOTOGRAPH ALBUMS, PHOTOGRAPH PRINTS, PHOTOGRAPHS, PICTORIAL PRINTS, PICTURE BOOKS, PICTURE POSTCARDS, PICTURES, PLACE CARDS, PLACE MATS OF PAPER, PLASTIC BAGS FOR DISPOSING OF PET WASTE, PLASTIC GIFT WRAP, PLASTIC SANDWICH BAGS, POCKET CALENDARS, POCKET MEMORANDUM BOOKS, POCKET SECRETARIES, POSTCARDS, POSTERS, PRINTED ART REPRODUCTIONS, PRINTED AWARDS, PRINTED CALENDARS, PRINTED CERTIFICATES, PRINTED EMBLEMS, PRINTED GUIDES FOR HOW TO TAKE CARE OF ONES PET, PRINTED INVITATIONS, PRINTED MUSIC BOOKS, PRINTED PAPER LABELS, PRINTED PAPER SIGNS, PRINTED PATTERNS, PRINTS, PROTECTIVE COVERS FOR BOOKS, RECIPE BOOKS, REFERENCE BOOKS DEALING WITH PET CARE, RUBBER ERASERS, RUBBER STAMPS, SANDWICH BAGS, SCHOOL WRITING BOOKS, SCRAPBOOK ALBUMS, SCRAPBOOKS, SERIES OF FICTION BOOKS, SKETCH BOOKS, SKETCH PADS, SKETCHES, SMALL BLACKBOARDS, SONG BOOKS, STAMP ALBUMS, STAMP CASES, STAMP PADS, STANDS FOR PEN OR PENCIL, STATIONERY, STATIONERY BOXES, STATIONERY CASES, STATIONERY FOLDERS, STATIONERY WRITING PAPER AND ENVELOPES, STICKERS, STORIES IN ILLUSTRATED FORM, STORY BOOKS, STUDY GUIDES, SYNDICATED MAGAZINE SECTIONS DEALING WITH YOUNG GIRLS AND PET CARE, SYNDICATED NEWSPAPER COLUMNS DEALING WITH YOUNG GIRLS AND PET CARE, TABLE CLOTHS OF PAPER, TABLE LINENS OF PAPER, TABLE MATS OF PAPER, TABLE NAPKINS OF PAPER, TALKING CHILDREN'S BOOKS, TELEPHONE DIRECTORIES, TEMPORARY TATTOOS, THREE-RING BINDERS, TRADING CARDS, TRANSFERS, NAMELY, IRON-ON TRANSFERS AND PLASTIC TRANSFERS SIMILAR TO DECALS, TRIVIA CARDS, WALL CALENDARS, WORKBOOKS DIRECTED TO EARLY CHILDHOOD EDUCATION, WRAPPING PAPER, WRITING PAPER, WRITING PADS, AND WRITING PAPER PADS (U.S. CLS. 2, 5, 22, 23, 29, 37, 38 AND 50).

#### CLASS 25—CLOTHING

FOR ANKLE BOOTS, ANKLE SOCKS, ANKLET SOCKS, FOOTWEAR, ATHLETIC FOOTWEAR, SHOES, ATHLETIC SHOES, BABY BIBS NOT OF PAPER, BABY BUNTING, BABY DOLL PAJAMAS, BANDANAS, BANDEAUX, BASEBALL CAPS, BATHING SUITS, BATHROBES, BEACH COVER-UPS, BEACH FOOTWEAR, BEACH SHOES, BEACHWEAR, BELTS, BERETS, BIKINIS, BLAZERS, BLOOMERS, BLOUSES, BODY SUITS, BONNETS, BOOTIES, BOOTS, BOTTOMS, BOXER SHORTS, BRAS, UNDERWEAR BRIEFS, CAMISOLES, CAMP SHIRTS, CAP VISORS, CAPS IN THE NATURE OF CLOTHING, CAPS WITH VISORS, CAPRI PANTS, CARDIGANS, CHILDREN'S CLOTH EATING BIBS, CHILDREN'S HEADWEAR, CLOGS, CLOTHING NAMELY, WRAP-AROUNDS, COATS, COSTUMES FOR USE IN ROLE-PLAYING GAMES, COVERALLS, COVER-UPS, CROP TOPS, CREEPERS, CULOTTES, DENIM JACKET, DENIM COATS, DENIM PANTS, DENIM SHIRTS, DENIM DRESSES, DOWN JACKET, DRESSES, DUNGAREES, EAR MUFFS, EMBOSSED SOLES AND HEELS OF RUBBER OR OF PLASTIC MATERIALS, FLEECE PULL-OVERS, FLEECE SHORTS, FOOTWEAR, FOUL WEATHER GEAR, GAUCHOS, GLOVES, GOWNS, HALLOWEEN COSTUMES, HATS, HEAD BANDS, HEAD SCARVES, HEAD SWEATBANDS, HEADWEAR, HEADGEAR, NAMELY, HATS, CAPS AND VISORS, HOSIERY, INFANTS' SHOES AND BOOTS, INFANTWEAR, JACKETS, JEANS, JERSEYS IN THE NATURE OF CLOTHING, JOGGING PANTS, JOGGING SUITS, JUMPERS, JUMPSUITS, KERCHIEFS, KNEE HIGHS, KNEE-HIGH STOCKINGS, KNICKERS, LAYETTES, LEGGINGS, LEOTARDS, LINGERIE, LOUNGEWEAR, MINISKIRTS, MITTENS, MOCK TURTLE-NECK SWEATERS, MUFFS, NECK BANDS, NECKERCHIEFS, NECKWEAR, NIGHT GOWNS, NIGHT SHIRTS, NIGHTCAPS, NIGHT-DRESSES, NIGHTWEAR, OVERALLS, PAJAMAS, PANTALOONS, PANTIES, SHORTS AND BRIEFS, PANTS, PANTYHOSE, PARKAS, PETTICOATS, PLASTIC BABY BIBS, PLAY SUITS, POLO SHIRTS, PONCHOS, PULL-OVERS, RAIN BOOTS, RAIN COATS, RAIN JACKET, RAIN SUITS, RAIN TROUSERS, RAINCOATS, RAINWEAR, RASH GUARDS, ROBES, ROMPERS, RUBBER

SHOES, RUBBERS, SANDALS, SARONGS, SCARVES, SHAWLS, SHIRTS, SHORTS, SKIRTS AND DRESSES, SKORTS, SLEEP SHIRTS, SLEEPWEAR, SLIPPERS, SMOCKS, SNEAKERS, SOCKS, STOCKINGS, SUITS; SUN VISORS, SUN SUITS, SURF WEAR, SUSPENDERS, SWEAT BANDS, SWEAT PANTS, SWEAT SHIRTS, SWEAT SHORTS, SWEAT SUITS, SWEATERS, SWIM TRUNKS, SWIMSUITS, SWIMWEAR, TANK TOPS, TEDDIES, TENNIS WEAR, TEXTILE DIAPERS, THONG FOOTWEAR, THONG UNDERWEAR, TIGHTS, TOPS IN THE NATURE OF CLOTHING, TROUSERS, TURTLE-NECK SWEATERS, TURTLENECKS, T-SHIRTS, UNDERGARMENTS, UNDERSHIRTS, UNDERWEAR, VESTS, V-NECK SWEATERS, WIND JACKETS, WRAPS IN THE NATURE OF CLOTHING, WRISTBANDS (U.S. CLS. 22 AND 39).

#### CLASS 41—EDUCATION AND ENTERTAINMENT

FOR PROVIDING A WEBSITE FEATURING ENTERTAINMENT FOR CHILDREN, ENTERTAINMENT SERVICES, NAMELY, PROVIDING AN ON-LINE COMPUTER GAME, ENTERTAINMENT IN THE NATURE OF AN ON-GOING TELEVISION PROGRAMS IN THE FIELD OF CARTOONS, PUBLISHING OF ILLUSTRATIONS, PUBLISHING OF BOOKS (U.S. CLS. 100, 101 AND 107).

TINA L. SNAPP, EXAMINING ATTORNEY

SN 77-897,909. TIMES NEWSPAPERS LIMITED, LONDON, UNITED KINGDOM, FILED 12-21-2009.

## THE SUNDAY TIMES

THE MARK CONSISTS OF STANDARD CHARACTERS WITHOUT CLAIM TO ANY PARTICULAR FONT, STYLE, SIZE, OR COLOR.

OWNER OF UNITED KINGDOM REG. NO. 2139752, DATED 10-26-2001, EXPIRES 7-22-2017.

OWNER OF U.S. REG. NO. 1,112,255.

NO CLAIM IS MADE TO THE EXCLUSIVE RIGHT TO USE "SUNDAY" AS TO INTERNATIONAL CLASSES 009, 035, 036 AND 041, APART FROM THE MARK AS SHOWN.

#### CLASS 9—ELECTRICAL AND SCIENTIFIC APPARATUS

FOR COMPUTER HARDWARE AND COMPUTER SOFTWARE FOR USE IN DATABASE MANAGEMENT FOR ELECTRONIC MOBILE DEVICES IN THE FIELD OF GENERAL NEWSPAPERS, NAMELY, CURRENT EVENTS, FINANCE, BUSINESS, ENTERTAINMENT, SPORTS, FASHION, AND LEISURE; COMPUTER PROGRAMS FOR USE IN DATABASE MANAGEMENT FOR ELECTRONIC MOBILE DEVICES IN THE FIELD OF GENERAL NEWSPAPER CONTENT, NAMELY, CURRENT EVENTS, FINANCE, BUSINESS, ENTERTAINMENT, SPORTS, FASHION, AND LEISURE; DATA STORAGE MEDIA, NAMELY, BLANK TAPES FOR STORAGE OF COMPUTER DATA; ELECTRONIC PUBLICATIONS, NAMELY, NEWSPAPERS AND NEWSPAPER ARTICLES FEATURING INFORMATION ABOUT CURRENT EVENTS, FINANCE, BUSINESS, ENTERTAINMENT, SPORTS, FASHION, AND LEISURE RECORDED ON COMPUTER MEDIA; BLANK CD-ROMS FOR SOUND OR VIDEO RECORDING; APPARATUS FOR RECORDING, TRANSMISSION AND REPRODUCTION OF SOUND OR IMAGES; BLANK MAGNETIC DATA CARRIERS, DATA PROCESSING EQUIPMENT AND COMPUTERS; REPLACEMENT PARTS FOR ALL THE AFORESAID GOODS (U.S. CLS. 21, 23, 26, 36 AND 38).

**CLASS 35—ADVERTISING AND BUSINESS**

FOR ADVERTISING INFORMATION AND BUSINESS SERVICES, NAMELY, ADVERTISING AND COMMERCIAL INFORMATION SERVICES PROVIDED VIA THE INTERNET; ADVERTISING AND MARKETING SERVICES, PUBLIC RELATION SERVICES, ADVERTISING AND PUBLICITY SERVICES, AND ADVERTISING AND PROMOTIONAL SERVICES; ADVERTISING, INFORMATION AND BUSINESS SERVICES, NAMELY, CONSUMER PRODUCT INFORMATION PROVIDED ON-LINE FROM A COMPUTER DATABASE AND FROM THE INTERNET; COMPILATION OF ADVERTISEMENTS FOR USE AS WEB PAGES ON THE INTERNET; CLASSIFIED ADVERTISING SERVICES; NEWS CLIPPING SERVICES (U.S. CLS. 100, 101 AND 102).

SN 77-899,206. WM. MICHAEL STEMLER, INCORPORATED, DBA DELTA HEALTH SYSTEMS, STOCKTON, CA. FILED 12-22-2009.

PARAGON HEALTH CARE NETWORK

**CLASS 36—INSURANCE AND FINANCIAL**

FOR PROVIDING INSURANCE AND FINANCIAL INFORMATION; PROVIDING INSURANCE AND FINANCIAL ANALYSIS, EVALUATION, ADVICE AND INFORMATION; FINANCIAL MANAGEMENT SERVICES; FINANCIAL ADVISORY SERVICES; FINANCIAL SERVICES RENDERED IN CONNECTION WITH CREDIT CARD SERVICES; INVESTMENT SCHEMES AND ACCOUNTS, NAMELY, INFORMATION AND ADVICE IN THE FIELD OF FINANCIAL INVESTMENTS, MORTGAGES, TAXES, PENSIONS AND INSURANCE; ALL THE AFORESAID INFORMATION AND SERVICES ALSO PROVIDED ON-LINE FROM A COMPUTER DATABASE AND FROM THE INTERNET (U.S. CLS. 100, 101 AND 102).

THE MARK CONSISTS OF STANDARD CHARACTERS WITHOUT CLAIM TO ANY PARTICULAR FONT, STYLE, SIZE, OR COLOR.

NO CLAIM IS MADE TO THE EXCLUSIVE RIGHT TO USE "HEALTH CARE NETWORK", APART FROM THE MARK AS SHOWN.

**CLASS 35—ADVERTISING AND BUSINESS**

FOR BUSINESS SERVICES IN THE FIELD OF HEALTH CARE PREFERRED PROVIDER ORGANIZATION (PPO) NETWORKS, NAMELY, CREDENTIALING AND ORGANIZING THIRD-PARTY CONTRACTORS, NAMELY, HOSPITALS, DOCTORS AND ANCILLARY PROVIDERS; ORGANIZING A HEALTH CARE PREFERRED PROVIDER ORGANIZATION NETWORK (U.S. CLS. 100, 101 AND 102).

**CLASS 36—INSURANCE AND FINANCIAL**

FOR ADMINISTERING A HEALTH CARE PREFERRED PROVIDER ORGANIZATION (PPO) NETWORK (U.S. CLS. 100, 101 AND 102).

C. DIONNE CLYBURN, EXAMINING ATTORNEY

**CLASS 38—COMMUNICATION**

FOR COMMUNICATION SERVICES AND INFORMATION SERVICES RELATING THERETO, NAMELY, ELECTRONIC MAIL AND INSTANT MESSAGING SERVICES; COMMUNICATION SERVICES, NAMELY, TRANSMISSION OF VOICE, AUDIO, VISUAL IMAGES AND DATA BY TELECOMMUNICATIONS NETWORKS, WIRELESS COMMUNICATION NETWORKS, THE INTERNET, INFORMATION SERVICES NETWORKS AND DATA NETWORKS; COMMUNICATION AND INFORMATION SERVICES, NAMELY, ELECTRONIC MAIL AND INSTANT MESSAGING, ALL PROVIDED ON-LINE FROM A COMPUTER DATABASE AND FROM THE INTERNET (U.S. CLS. 100, 101 AND 104).

SN 77-901,936. SEQUEL MEDIA & SERVICES, LLC, FAIRFAX, VA. FILED 12-29-2009.

**CLASS 41—EDUCATION AND ENTERTAINMENT**

FOR PROVISION OF INFORMATION RELATING TO EDUCATIONAL AND ENTERTAINMENT ACTIVITIES AND EVENTS FOR CHILDREN AND ADULTS; PUBLISHING SERVICES, NAMELY, NEWSPAPERS, MAGAZINES, JOURNALS, PERIODICALS, NEWSPAPER ARTICLES AND BOOKS; PUBLICATION OF PRINTED MATTER AND PRINTED PUBLICATIONS, NAMELY, NEWSPAPERS, MAGAZINES, JOURNALS, PERIODICALS, NEWSPAPER ARTICLES AND BOOKS; PROVIDING INFORMATION RELATING TO EDUCATIONAL SERVICES, AND PROVISION OF INFORMATION RELATING TO MULTIMEDIA PUBLISHING; PROVISION OF INFORMATION RELATING TO SPORTS; ORGANIZATION OF COMPETITIONS NAMELY, QUIZZES AND GAMES; NEWS PROGRAM SERVICES; ALL THE AFORESAID SERVICES ALSO PROVIDED ON-LINE FROM A COMPUTER DATABASE AND FROM THE INTERNET; PROVIDING NEWS IN THE NATURE OF CURRENT EVENT REPORTING (U.S. CLS. 100, 101 AND 107).

ASMAT KHAN, EXAMINING ATTORNEY

ECRIMETOOLS.COM

THE MARK CONSISTS OF STANDARD CHARACTERS WITHOUT CLAIM TO ANY PARTICULAR FONT, STYLE, SIZE, OR COLOR.

**CLASS 9—ELECTRICAL AND SCIENTIFIC APPARATUS**

FOR DOWNLOADABLE ELECTRONIC NEWSLETTERS AND AND ISSUE PAPERS IN THE FIELDS OF LAW AND THE INTERNET (U.S. CLS. 21, 23, 26, 36 AND 38).



**CLASS 35—ADVERTISING AND BUSINESS**

FOR TRADEMARK, TRADE NAME AND DOMAIN NAME MONITORING SERVICES; PROVIDING AN ONLINE DIRECTORY INFORMATION SERVICE FEATURING TELEPHONE NUMBERS, ADDRESSES AND BUSINESS INFORMATION; ONLINE RETAIL STORE SERVICES FEATURING BOOKS; ADVERTISING AND DIRECTORY SERVICES, NAMELY, PROMOTING THE SERVICES OF OTHERS BY PROVIDING A WEB PAGE FEATURING LINKS TO THE WEBSITES OF OTHERS; PROVIDING AN ONLINE COMMERCIAL INFORMATION DIRECTORY ON THE INTERNET; MARKET ANALYSIS SERVICES; PROVIDING AN ONLINE SEARCHABLE DATABASE FEATURING BUSINESS INFORMATION ABOUT THE RELATIONSHIPS BETWEEN SUBJECT WEBSITES, INTERNET PROTOCOL ADDRESSES OR DOMAIN NAMES ON THE INTERNET USED TO RESEARCH, TRACK AND INVESTIGATE POTENTIAL OWNERSHIP OF OR AFFILIATION BETWEEN WEBSITES THAT ARE CONNECTED BY HYPERLINKS (U.S. CLS. 100, 101 AND 102).

**CLASS 42—SCIENTIFIC AND COMPUTER SERVICES**

FOR PROVIDING AN ONLINE SEARCHABLE DATABASE FEATURING INFORMATION ABOUT THE CHARACTERISTICS OF TARGETED SERVERS ON THE INTERNET, INFORMATION ABOUT SHARED SERVER ARRANGEMENTS BETWEEN SUBJECT WEBSITES, HISTORIC INFORMATION ABOUT INTERNET HOSTING ARRANGEMENTS FOR SUBJECT WEBSITES; DATA RETRIEVAL SERVICES PERFORMED BY COMPUTER (U.S. CLS. 100 AND 101).

**CLASS 45—PERSONAL AND LEGAL SERVICES**

FOR PROVIDING AN ONLINE SEARCHABLE DATABASE FEATURING LEGAL INFORMATION ABOUT CASE LAW, STATUTORY LAW, TREATIES AND RELATED REGULATIONS AND POLICY; COMPUTER SERVICES PROVIDED THROUGH A GLOBAL COMPUTER NETWORK, NAMELY, COMPUTER-ASSISTED LEGAL RESEARCH SERVICES; COMPUTER SERVICES, NAMELY, PROVIDING DATABASES FEATURING LEGAL INFORMATION (U.S. CLS. 100 AND 101).

GINA HAYES, EXAMINING ATTORNEY

SN 77-902,064. BACK APP AS, 1929 AULI, NORWAY, FILED 12-29-2009.

# BACK APP

THE MARK CONSISTS OF STANDARD CHARACTERS WITHOUT CLAIM TO ANY PARTICULAR FONT, STYLE, SIZE, OR COLOR.

OWNER OF NORWAY REG. NO. 247066, DATED 8-5-2008, EXPIRES 8-5-2018.

NO CLAIM IS MADE TO THE EXCLUSIVE RIGHT TO USE "BACK", APART FROM THE MARK AS SHOWN.

**CLASS 10—MEDICAL APPARATUS**

FOR APPARATUS FOR PHYSICAL TRAINING FOR MEDICAL USE (U.S. CLS. 26, 39 AND 44).

**CLASS 28—TOYS AND SPORTING GOODS**

FOR BODY-TRAINING APPARATUS (U.S. CLS. 22, 23, 38 AND 50).

DANNEAN HETZEL, EXAMINING ATTORNEY

SN 77-903,495. HILLARY ROSE, LLC, LOS ANGELES, CA. FILED 12-31-2009.

# HEAL! BY HRY

THE MARK CONSISTS OF STANDARD CHARACTERS WITHOUT CLAIM TO ANY PARTICULAR FONT, STYLE, SIZE, OR COLOR.

NO CLAIM IS MADE TO THE EXCLUSIVE RIGHT TO USE "HEAL", APART FROM THE MARK AS SHOWN.

THE NAME(S), PORTRAIT(S), AND/OR SIGNATURE(S) SHOWN IN THE MARK IDENTIFIES HILLARY ROSE YABLON, WHOSE CONSENT(S) TO REGISTER IS MADE OF RECORD.

**CLASS 3—COSMETICS AND CLEANING PREPARATIONS**

FOR NON-MEDICATED SKIN PREPARATIONS; NON-MEDICATED SKIN LOTIONS, SKIN CREAMS, SKIN GELS, SKIN OINTMENTS AND SKIN SERUMS; COSMETICS (U.S. CLS. 1, 4, 6, 50, 51 AND 52).

**CLASS 5—PHARMACEUTICALS**

FOR MEDICATED SKIN CARE PREPARATIONS, MEDICINAL HERBAL SKIN CARE PREPARATIONS FOR TREATMENT OF WOUNDS, SKIN IRRITATIONS, AND OTHER SKIN CONDITIONS; MEDICATED SKIN LOTIONS, SKIN CREAMS, SKIN GELS; MEDICATED SKIN OINTMENTS, NAMELY, ANTIBIOTIC OINTMENTS, AND ANTI-INFLAMMATORY OINTMENTS; MEDICATED SKIN SERUMS FOR TREATMENT OF WOUNDS, SKIN IRRITATIONS, AND OTHER SKIN CONDITIONS; MEDICINAL HERBAL PREPARATIONS IN THE NATURE OF HERBAL SKIN LOTIONS, SKIN CREAMS, SKIN GELS, SKIN OINTMENTS AND SKIN SERUMS; TOPICAL ANALGESICS, TOPICAL PREPARATIONS FOR TREATMENT OF WOUNDS, SKIN IRRITATIONS, AND OTHER SKIN CONDITIONS, NAMELY, TOPICAL PREPARATIONS FOR TREATING AND PREVENTING INFLAMMATION IN OPEN WOUNDS, CUTS, STITCHES, ABRASIONS, INSECT BITES, HOT SPOTS, RASHES; ANTI-ITCH OINTMENTS, CREAMS, LOTIONS, GELS AND SERUMS; ANTI-ITCH OINTMENTS, CREAMS, LOTIONS, GELS AND SERUMS FOR ANIMALS; MEDICINAL HERBAL PREPARATIONS TO ASSIST IN THE HEALING OF WOUNDS AND SKIN IRRITATIONS, FOR USE ON HUMANS AND ANIMALS (U.S. CLS. 6, 18, 44, 46, 51 AND 52).

SAIMA MAKHDOOM, EXAMINING ATTORNEY

SN 77-904,167. MITSUBISHI ELECTRIC CORPORATION, TOKYO, JAPAN, FILED 1-4-2010.

# MITSUBISHI

THE MARK CONSISTS OF STANDARD CHARACTERS WITHOUT CLAIM TO ANY PARTICULAR FONT, STYLE, SIZE, OR COLOR.

OWNER OF U.S. REG. NOS. 780,988, 1,350,392 AND OTHERS.

THE ENGLISH TRANSLATION OF "MITSUBISHI" IN THE MARK IS "THREE RHOMBOIDS".

**CLASS 7—MACHINERY**

FOR AIR COOLED CONDENSERS, ELECTRIC DISTRIBUTORS FOR VEHICLE, SOLAR POWER ELECTRICITY GENERATORS (U.S. CLS. 13, 19, 21, 23, 31, 34 AND 35).

**CLASS 9—ELECTRICAL AND SCIENTIFIC APPARATUS**

FOR MOISTURE METERS, AUTOMATIC TITRATORS, TOTAL NITROGEN ANALYZERS, TOTAL ORGANIC HALOGEN ANALYZERS, TOTAL SULFUR ANALYZERS, TOTAL SULFUR CHLORIDE ANALYZERS, ELECTRONIC CONTROLLED AIR FLOW SENSORS FOR VEHICLE, ELECTRONIC REVOLUTION SENSORS FOR VEHICLE, WATER TEMPERATURE SENSORS, AIR TEMPERATURE SENSORS, ELECTRONIC CONTROL UNITS FOR ENGINE OF VEHICLE, ELECTRIC IGNITERS FOR VEHICLE USED IN CONNECTION WITH BALLASTS TO START DISCHARGE LAMPS, ELECTRONIC CONTROLS FOR ANTISKID BRAKE CONTROL UNITS FOR VEHICLES, ELECTRONIC CONTROLS FOR POWER STEERING UNITS FOR VEHICLES, TRANSMISSION CONTROL UNITS FOR LAND VEHICLE ELECTRONIC CONTROLS FOR TRANSMISSION CONTROL UNITS FOR LAND VEHICLES, MILLIMETER WAVE SENSORS, GRAVITY SENSORS, ELECTRONIC LOCATION AND IMMOBILIZATION DEVICES INSTALLED AFTER PURCHASE FOR USE WITH VEHICLES, ACCELERATION SENSORS, MICROWAVE RADARS, ELECTRIC TOLL CONTROL APPARATUS FOR LAND VEHICLE, SIDE IMPACT SENSORS FOR LAND VEHICLE, CONTACT IMAGE SENSORS, SECURITY CAMERAS, INFRARED IMAGING APPARATUS FOR NON-MEDICAL PURPOSES, IMAGE SENSORS, ELECTRIC TIMERS, ELECTRICITY METERS, ELECTRIC COMMUNICATION SYSTEM FOR BUSINESS USE COMPRISING OF DEVICE FOR TRANSPORTING, SWITCHING AND AGGREGATING VOICE, DATA AND VIDEO COMMUNICATIONS ACROSS MULTIPLE NETWORK INFRASTRUCTURES AND COMMUNICATION PROTOCOLS; OPTICAL NETWORK PRODUCTS, NAMELY, SWITCHES, MULTIPLEXERS, AMPLIFIERS, OPTICAL TRANSPORTERS, OPTOELECTRONIC TRANSCIEVERS, COMMUNICATION HUBS, OPTICAL WAVE GUIDES; TELECOMMUNICATIONS NETWORK HARDWARE AND SOFTWARE FOR INTERCONNECTING, MANAGING, CONTROLLING AND OPERATING ENTERPRISE, LOCAL AND WIDE AREA NETWORKS; OPTICAL TRANSPORT HARDWARE FOR USE IN THE TRANSMISSION AND ROUTING OF INTERNET, VOICE, VIDEO AND DATA COMMUNICATIONS; RAILROAD STATION INFORMATION APPARATUS COMPRISING OF COMPUTERS FOR GATHERING INFORMATION OF POWER EQUIPMENT, TELECOMMUNICATION EQUIPMENT, MACHINERY CONTROLLED PANEL AUTO FIRE ALARM EQUIPMENT OR DISASTER PREVENTION EQUIPMENT AND DISPLAY MONITORS DISPLAYING SUCH INFORMATION; RAILROAD ROOF TOP MONITORING APPARATUS COMPRISING OF CAMERAS FOR TAKING PHOTOGRAPHS OF ROOF TOP AND PANTOGRAPHS OF MOVING RAILROAD AND COMPUTERS FOR CHECKING THE STATUS OF SAID ROOF TOP OR PANTOGRAPH; WHEEL SHAPE MEASURING APPARATUS COMPRISING OF CAMERAS, LASER LIGHT SOURCES, FOR AUTOMATICALLY CALCULATING THE MEASUREMENTS OF DIAMETER, THICKNESS, HEIGHT AND RELATED INFORMATION OF THE TIRES OF RAILROAD, AND COMPUTER FOR MANAGING SAID VALUES OF MEASUREMENTS; MAGNETIC CONTACTORS, INDUSTRIAL TIME SWITCHES, ELECTRIC SWITCHES, MAGNETIC SWITCHES, SWITCH BOXES, ELECTRIC CIRCUIT BREAKERS, ELECTRIC RELAYS, GAS CIRCUIT BREAKERS, VACUUM CIRCUIT BREAKERS, POWER TRANSFORMER AND ELECTRIC SWITCHGEARS, LIQUID RHEOSTATS, SWITCH GEARS, MANUAL AND AUTOMATIC SWITCH BOARDS, ELECTRIC CONTROL PANELS FOR TRANSMISSION SYSTEM, ELECTRIC CONTROL PANELS FOR POWER PLANT, ELECTRICAL DISTRIBUTION BOARDS, ELECTRIC DISTRIBUTION BOXES, AC POWER CONTROLLERS, AMPLIFIERS, ELECTRONIC OPTICAL TERMINAL BOXES, BRUSHLESS STATIC EXCITERS, ELECTRONIC CONTROLLERS FOR FACTORY AUTOMATION, ELECTRONIC NUMERICAL CONTROLS FOR MACHINE TOOLS, CRUISE CON-

TROLS FOR MOTOR VEHICLE, MODEMS, LIGHTNING ARRESTERS, ELECTRIC POWER SUBSTATIONS IN WHICH ALL EQUIPMENTS ARE HOUSED IN GROUNDED METAL ENCLOSURES SEALED AND FILLED WITH SULFUR HEXAFLUORIDE GAS, ELECTRICAL REACTORS, ELECTRIC CONNECTORS, ELECTRIC CONVERTERS, ELECTRIC REGULATORS, ELECTRICITY CURRENT LIMITERS, GAS INSULATED SUBSTATION, VOLTAGE REGULATORS, ELECTRIC ENERGY MANAGEMENT APPARATUS COMPRISING OF COMPUTER HARDWARE AND SOFTWARE, AUTOMATIC DISTRIBUTION APPARATUS FOR ELECTRIC POWER PLANT COMPRISING OF COMPUTER HARDWARE AND SOFTWARE, ELECTRIC POWER TRANSMISSION APPARATUS COMPRISING OF THYRISTOR VALVES AND AC/DC CONVERTERS; TESTERS FOR USE IN TESTING QUALITY AND OTHER CONDITIONS OF WARE, NAMELY, CONTROL BOARDS, MOTORS, ENGINES, CLUTCHES; VACUUM SWITCH TUBES FOR RADIOS, PHOTO VOLTAIC MODULES FOR ELECTRICITY GENERATION, PHOTO VOLTAIC INVERTERS, UNINTERRUPTIBLE ELECTRIC POWER SUPPLYING APPARATUS, WATT HOUR METERS, LASER OSCILLATORS, ELECTRIC CABLES, COAXIAL CABLES, OPTICAL FIBER CABLES, PHOTO COPY MACHINES, CALCULATORS, PHOTOGRAPHIC CAMERAS, TELEPHONE APPARATUS, MOBILE TELEPHONES, NETWORK ROUTERS, VIDEO TRANSMISSION APPARATUS, FACSIMILE MACHINES, VOICE-FREQUENCY CONVERTERS, TIME-DIVISION DIGITAL MULTIPLEXORS, DIGITAL CIRCUIT MULTIPLICATION EQUIPMENT, INTERFACES FOR COMPUTERS, LOUDSPEAKERS FOR AUDIO, CAR RADIOS, CAR STEREOS, NAVIGATIONAL INSTRUMENTS FOR LAND VEHICLE, LOUDSPEAKERS FOR AUDIO SYSTEMS, STEREO AMPLIFIERS, DIGITAL AUDIO DISK PLAYERS, DIGITAL AUDIO TAPE PLAYERS, VIDEO CASSETTE RECORDERS, DIGITAL VIDEO EQUIPMENT, NAMELY, CAMERAS AND DISC DRIVES, SOUND RECORDING APPARATUS, SOUND REPRODUCTION APPARATUS, TELEVISION RECEIVERS, DVD PLAYERS, DVD RECORDERS, CD PLAYERS, VIDEO PROJECTORS, VIDEO COPY PROCESSORS, CD CHANGERS, DIGITAL COLOR PRINTERS, LARGE SCREEN VIDEO DISPLAYS, VIDEO DISPLAY WALLS, IMAGE DISPLAY PANELS AND SCREENS, MULTIMEDIA PROJECTORS, LIQUID CRYSTAL DISPLAY PROJECTORS, DIGITAL PHOTO PRINTERS, SUPERVISORY CONTROL AND DATA ACQUISITIONS SYSTEM MASTER STATION COMPRISING OF COMPUTER HARDWARE, ELECTRONIC DISPLAY INTERFACES, OPERATING SYSTEMS SOFTWARE, AND APPLICATION SOFTWARE FOR USE IN THE ELECTRIC ENERGY SUPPLY; ELECTRONIC PLANT CONTROLLERS COMPRISING OF SUPERVISORY DEVICE FOR MONITORING MACHINES IN THE INDUSTRIAL PLANT, CENTRAL PROCESSING UNIT, INPUT/OUTPUT INTERFACE OF CONTROL SIGNAL, AND DISPLAY, MONITORING AND DIAGNOSING THE ACTIVITY OR STATUS OF MACHINES IN THE INDUSTRIAL PLANT; MONITORING SYSTEMS FOR POWER TRANSMISSION AND DISTRIBUTION, COMPRISING OF VARIOUS METERS AND SENSORS, NAMELY, VOLTAGE METERS, AMMETERS, TEMPERATURE SENSORS, PRESSURE SENSORS ALL FOR SENSING THE STATUS OF ELECTRIC POWER TRANSMISSION AND DISTRIBUTION IN VARIOUS FACTORIES AND PLANTS, SUPERVISORY MACHINES FOR DIAGNOSING THE STATUS VIA SAID METERS AND SENSORS, AND GRAPHIC PANELS FOR DISPLAY SAID STATUS; ELECTRIC INSTALLATIONS FOR REMOTE CONTROL OF INDUSTRIAL OPERATION, COMPRISING OF SUPERVISORY DEVICE FOR MONITORING MACHINES IN THE INDUSTRIAL PLANT, CENTRAL PROCESSING UNIT, INPUT/OUTPUT INTERFACE OF CONTROL SIGNAL, AND DISPLAY, MONITORING AND DIAGNOSING THE ACTIVITY OR STATUS OF MACHINES IN THE INDUSTRIAL PLANT; ELECTRICAL CONTROLLERS FOR CONTROLLING THE MOVEMENTS OF ELEVATOR, VEHICLE TRACKING DEVICES COMPRISED OF CELLULAR RADIO MODULES, COMPUTER SOFTWARE AND COMPUTER HARDWARE, SENSORS, TRANSMITTERS, RECEIVERS AND GLOBAL POSITIONING SATELLITE RECEIVERS, ALL FOR USE IN CONNECTION WITH VEHICLE TRACKING, VEHICLE MONITORING AND ANTI-THEFT VEHICLE ALARMS, ANTENNAS, WAVEGUIDES FOR HIGH POWER BEAM DELIVERY, ELECTRONIC DATA LOGGERS, LASER DISPLAY MONITORS, LIQUID-CRYSTAL DISPLAYS, PLASMA

DISPLAY PANELS, PRINTERS FOR USE WITH COMPUTERS, THERMAL PRINTERS, COPYING APPARATUS AND MACHINES, OPTICAL DISK DRIVES, BLANK OPTICAL DATA MEDIA CARRIERS, ENCODED MAGNETIC CARDS, BLANK MAGNETIC DISKS, BLANK OPTICAL DISK, COMPUTERS, COMPUTER NETWORKING HARDWARE, COMPUTER SERVERS; COMPUTER SOFTWARE FOR COMMUNICATIONS, NAMELY, FOR USE IN THE NETWORK COMMUNICATIONS IN THE AUTOMATED FACTORY; COMPUTER SOFTWARE FOR DATA PROCESSING; COMPUTER SOFTWARE FOR ENSURING THE SECURITY OF DATA BY MEANS OF CRYPTOGRAPHY; COMPUTER SOFTWARE FOR USE IN DEFINING AND EDITING THE WORKFLOW OF BUSINESS; COMPUTER SOFTWARE FOR USE IN DATABASE MANAGEMENT FOR BUSINESS USE; COMPUTER SOFTWARE FOR SECURITY OF DATA TO BE TRANSMITTED OVER COMPUTER NETWORKS; COMPUTER SOFTWARE FOR USE IN MOBILE AGENT TECHNOLOGY TO INTEGRATE AND CONNECT APPLICATIONS OVER THE GLOBAL COMPUTER NETWORK WITHIN A SINGLE ENTERPRISE OR ACROSS MULTIPLE ENTERPRISES; COMPUTER SOFTWARE FOR SECURING INFORMATION SYSTEMS BY MEANS OF CRYPTOGRAPHY; COMPUTER SOFTWARE FOR USE IN THE GENERAL BUSINESS WORKFLOW MANAGEMENT, DOCUMENT MANAGEMENT, INTEGRATED DATABASE MANAGEMENT, SALES ANALYSIS, COMMUNICATIONS AND LOG ANALYSIS AND COMPUTER NETWORKS SECURITY; COMPUTER SOFTWARE FOR USE IN EXCHANGE, USAGE AND MANAGEMENT OF TECHNICAL INFORMATION VIA A COMPUTER NETWORK IN A PLANT PROJECT MANAGEMENT; COMPUTER SOFTWARE FOR USE IN STARTING AND CONTROLLING OPERATION OF TESTING MACHINES AND APPARATUS; COMPUTER SOFTWARE FOR USE IN REMOTELY MONITORING THE ONLINE OPERATION OF LASER MACHINES FOR METALWORKING; COMPUTER SOFTWARE FOR USE IN MONITORING AND DIAGNOSING MACHINES AND EQUIPMENT FOR FACTORY AUTOMATION; COMPUTER SOFTWARE FOR USE IN ELECTRICITY CONTROL OF FACTORY MACHINES FOR ENERGY SAVING; COMPUTER SOFTWARE FOR USE IN DISPLAYING IMAGES AND DRAWINGS ON MONITOR SCREEN USED IN THE FIELD OF FACTORY AUTOMATION; COMPUTER SOFTWARE FOR USE IN SETTING PARAMETERS AND CREATING PROGRAMS FOR CONTROL AND OPERATION OF MACHINES AND EQUIPMENT FOR FACTORY AUTOMATION, AND STARTING, CONTROLLING, OPERATING, TESTING AND INSPECTING SAID MACHINES AND EQUIPMENT; COMPUTER SOFTWARE FOR ENGINEERING, DEBUGGING AND MAINTENANCE OF COMPUTER PROGRAM FOR CONTROLLING SERVO MOTOR; COMPUTER SOFTWARE FOR USE IN THE SETUP AND AUTOMATIC CONTROL OF MECHANICAL AND INDUSTRIAL PROCESSORS IN FACTORY; COMPUTER SOFTWARE FOR ADMINISTRATION, CONTROL, MANAGEMENT AND DEVELOPMENT OF PROCESSES, SYSTEMS AND MACHINERY FOR USE IN FACTORY AUTOMATION; COMPUTER SOFTWARE FOR LINKAGE, DATA INTEGRATION AND DATA SHARING WITH OTHER COMPUTER SOFTWARE FOR USE IN FACTORY AUTOMATION; COMPUTER SOFTWARE FOR USE IN SIMULATING, MONITORING, WATCHING, CONTROLLING AND RECORDING OPERATION OF POWER AND INDUSTRIAL PLANTS FOR MANAGEMENT OF OPERATION AND SECURITY THEREOF, AND FOR USE IN DESIGNING, CONSTRUCTING, REPAIRING AND MAINTAINING POWER AND INDUSTRIAL PLANTS; COMPUTER SOFTWARE FOR USE IN THE DATA MANAGEMENT OF CUSTOMERS, SALES AND BIDDING SITUATIONS IN THE BUSINESS FIELD OF SALES OF ENERGY AND ELECTRIC POWER AND IN THE BUSINESS FIELD OF SALES, CONSTRUCTION, REPAIR AND MAINTENANCE OF POWER AND INDUSTRIAL PLANTS; DATA PROCESSORS, IC CARDS, BLANK COMPACT DISKS, ELECTRONIC ENCRYPTION UNITS, TIME LOCATION RECORDERS, WIRED AND WIRELESS RADIO AND TELEPHONE TRANSMITTERS AND RECEIVERS, TRANSMITTING AND RECEIVING APPARATUS FOR RADIO AND TELEVISION BROADCASTING, ELECTRONIC COMMUNICATIONS NETWORK COMPUTER HARDWARE, ELECTRIC MOTOR CONTROLS, BUILDING AUTOMATION SYSTEMS, COMPRISING OF COMPUTER SERVERS, COMPUTER DISPLAY MONITORS, PRINTERS, MONITORING, DATA ANALYZING AND DIAGNOSING OF THE STATUS OF ELECTRICITY

SUPPLYING, LIGHTING, AIR CONDITIONING, SECURITY OF THE BUILDING; ELECTRONIC PROGRAMMABLE CONTROLLERS FOR FACTORY AUTOMATION, ELECTRONIC CONTROLLERS FOR SERVO MOTOR, AMPLIFIERS FOR SERVO MOTOR, HUMAN INTERFACE MONITORS FOR FACTORY AUTOMATION, ELECTRONIC TENSION CONTROLLERS FOR FACTORY AUTOMATION, SEMICONDUCTOR DEVICES, POWER SEMICONDUCTORS, CATHODE RAY TUBES, DRY BATTERIES, RADAR APPARATUS, LASERS NOT FOR MEDICAL USES, SOLAR BATTERIES, LIGHT EMITTING DIODES, SOLAR POWER SATELLITES, ELECTRIC CONTROL PANELS AND ELECTRIC CONTROL BOARDS FOR USE IN MONITORING, SUPERVISING AND CONTROLLING THE STATUS OF OPERATIONS OF NUCLEAR POWER PLANTS, IN-VEHICLE EQUIPMENT FOR ETC (ELECTRONIC TOLL COLLECTION SYSTEM) COMPRISING OF A TRANSPONDER AND MAGNETIC CARD, INTELLIGENT TRANSPORT SYSTEMS (ITS) COMPRISING OF NAVIGATION SYSTEMS, ELECTRONIC TOLL COLLECTION SYSTEMS COMPRISING OF ANTENNAS AND CONTROLLERS INSTALLED IN THE ROAD SIDE WHICH COMMUNICATE WITH IN-VEHICLE EQUIPMENT FOR ETC (U.S. CLS. 21, 23, 26, 36 AND 38).

#### CLASS 11—ENVIRONMENTAL CONTROL APPARATUS

FOR APPARATUS FOR LIGHTING, NAMELY, CEILING LIGHTS, AUTOMOBILE LIGHTS, ELECTRIC LAMPS, LED LAMPS, FLASHLIGHTS, LIGHT BULBS, SOCKETS FOR ELECTRIC LIGHTS; HEAT PIPES TO COOL HEAT PRODUCING COMPONENTS; HEAT EXCHANGERS, FAN COIL UNITS FOR ROOM HEATERS AND WATER CHILLERS, SOLAR WATER HEATERS, REFRIGERATORS, AIR COOLED REFRIGERATOR CONDENSERS, HEAT PUMP CHILLERS, BRINE CHILLERS, CONDENSING UNITS, ELECTRIC HAND DRYING APPARATUS FOR WASHROOM, AIR CONDITIONERS, AIR CONDITIONERS FOR VEHICLE, HOUSEHOLD AIR CLEANERS, DEHUMIDIFIERS, HUMIDIFIERS, AIR PURIFIERS, ELECTRIC FANS, VENTILATORS FOR RESIDENTIAL, COMMERCIAL AND INDUSTRIAL USE, VENTILATION HOODS, GAS STOVES, GAS HEATERS, KEROSENE HEATERS, ELECTRIC COOKERS WITH INDUCTION HEATERS, CO<sub>2</sub> RECOVERY EQUIPMENT FROM FLUE GASES OF COMBUSTION APPARATUS, NAMELY, BOILERS, GAS TURBINES AND FURNACES; OZONE WATER TREATMENT APPARATUS, NAMELY, OZONIZERS (U.S. CLS. 13, 21, 23, 31 AND 34).

DARRYL SPRULL, EXAMINING ATTORNEY

---

SN 77-904.205. U-NICA INTERNATIONAL AG, MALANS, SWITZERLAND, FILED 1-4-2010.

# NANOTRACE

THE MARK CONSISTS OF STANDARD CHARACTERS WITHOUT CLAIM TO ANY PARTICULAR FONT, STYLE, SIZE, OR COLOR.

PRIORITY CLAIMED UNDER SEC. 44(D) ON SWITZERLAND APPLICATION NO. 57468/2009, FILED 7-8-2009, REG. NO. 599276, DATED 7-8-2009, EXPIRES 7-8-2019.

**CLASS 9—ELECTRICAL AND SCIENTIFIC APPARATUS**

FOR OPTICAL READERS; DATA PROCESSING EQUIPMENT; INFRARED DETECTORS FOR USE IN INDUSTRIAL APPLICATIONS; TRACKING DEVICES, NAMELY, COMPUTER HARDWARE AND SOFTWARE SYSTEM FOR TRACKING PEOPLE, OBJECTS AND PETS USING GPS DATA ON A DEVICE ON THE TRACKED PEOPLE, OBJECTS AND PETS; MARKING AND ENCODING DEVICES, NAMELY, LASERS FOR INDUSTRIAL USE; DATA ENCODING DEVICES, NAMELY, ELECTRONIC ENCRYPTION UNITS FOR USE IN OPTICAL AND CHEMICAL ENCODING METHODS; LASERS NOT FOR MEDICAL USE (U.S. CLS. 21, 23, 26, 36 AND 38).

**CLASS 40—MATERIAL TREATMENT**

FOR TREATMENT AND MARKING OF MATERIALS AND OBJECTS, NAMELY, AFFIXING AND EMBEDDING PRODUCT AUTHENTICATION SECURITY DEVICES AND MATERIALS IN A WIDE VARIETY OF PRODUCTS AND DOCUMENTS TO PROTECT AGAINST COUNTERFEITING, TAMPERING, AND DIVERSION, AND TO ENSURE THE INTEGRITY OF GENUINE PRODUCTS AND DOCUMENTS (U.S. CLS. 100, 103 AND 106).

**CLASS 42—SCIENTIFIC AND COMPUTER SERVICES**

FOR SCIENTIFIC AND TECHNOLOGICAL SERVICES, NAMELY, ENGINEERING SERVICES FOR THE PLANNING AND DEVELOPMENT OF PRODUCT IDENTIFICATION SYSTEMS, SECURITY SYSTEMS AND PRODUCT TRACKING SYSTEMS (U.S. CLS. 100 AND 101).

MICHAEL LITZAU, EXAMINING ATTORNEY

SN 77-904,865. CLAUD, COLLING, GAMMELSDORF, FED REP GERMANY, FILED 1-5-2010.

**GALEFORCE**

THE MARK CONSISTS OF STANDARD CHARACTERS WITHOUT CLAIM TO ANY PARTICULAR FONT, STYLE, SIZE, OR COLOR.

OWNER OF ERPN CMNTY TM OFC REG. NO. 8442361, DATED 3-5-2010, EXPIRES 7-22-2019.

**CLASS 7—MACHINERY**

FOR MACHINES AND INSTALLATIONS CONSTRUCTED THEREFROM FOR RENEWABLE ENERGY GENERATION, NAMELY, WIND ENERGY INSTALLATIONS, NAMELY, WIND ENERGY CONVERTERS FOR CONVERTING WIND ENERGY INTO ELECTRICITY, WIND TURBINES, WIND TURBINE ROTORS, WIND TURBINE LIFT TYPES, WIND TURBINE ROTOR BLADES AND ROTORS, VERTICAL TURBINES FOR WIND ENERGY INSTALLATIONS, PARTS FOR AFORESAID GOODS (U.S. CLS. 13, 19, 21, 23, 31, 34 AND 35).

**CLASS 9—ELECTRICAL AND SCIENTIFIC APPARATUS**

FOR ELECTRIC APPARATUS, INSTRUMENTS AND MACHINES, AND INSTALLATIONS CONSTRUCTED THEREFROM FOR GENERATING ENERGY BY MEANS OF WIND, NAMELY, ELECTRICAL TRANSFORMERS, ELECTRIC LINES, CIRCUIT CLOSERS, CIRCUIT BREAKERS, AMPERE METERS, TRANSDUCERS, ELECTRIC COMMUTATORS, FREQUENCY CONVERTERS, INVERTERS, CONTROL CABINETS, SWITCHING EQUIPMENT; COMPUTER PROGRAMS FOR CONTROLLING WIND ENERGY INSTALLATIONS; DATA PROCESSORS AND COMPUTERS, EXCLUSIVELY FOR MONITORING AND CONTROLLING WIND ENERGY INSTALLATIONS; PARTS FOR AFORESAID GOODS (U.S. CLS. 21, 23, 26, 36 AND 38).

**CLASS 11—ENVIRONMENTAL CONTROL APPARATUS**

FOR ELECTRICITY POWER PLANTS (U.S. CLS. 13, 21, 23, 31 AND 34).

**CLASS 37—CONSTRUCTION AND REPAIR**

FOR ASSEMBLY, MAINTENANCE AND TECHNICAL SERVICING ADVICE OF WIND ENERGY INSTALLATIONS (U.S. CLS. 100, 103 AND 106).

**CLASS 42—SCIENTIFIC AND COMPUTER SERVICES**

FOR TECHNICAL CONSULTANCY FOR OPERATORS OF WIND ENERGY INSTALLATIONS, NAMELY, TROUBLESHOOTING OF COMPUTER SOFTWARE PROBLEMS (U.S. CLS. 100 AND 101).

SHAUNIA CARLYLE, EXAMINING ATTORNEY

SN 77-909,565. SANTA CLARITA COMMUNITY COLLEGE DISTRICT, SANTA CLARITA, CA. FILED 1-11-2010.



NO CLAIM IS MADE TO THE EXCLUSIVE RIGHT TO USE "COLLEGE", APART FROM THE MARK AS SHOWN.

THE MARK CONSISTS OF TWO LINES AT AN ANGLE TO THE LEFT OF A TRIANGLE ABOVE THE WORDS "COLLEGE OF THE CANYONS" ALL ABOVE THE IMAGE OF TWO LINES AT AN ANGLE TO THE LEFT OF A TRIANGLE.

**CLASS 35—ADVERTISING AND BUSINESS**

FOR CONSULTING SERVICES IN THE FIELD OF HIGHER EDUCATION ADMINISTRATION; EDUCATION LEADERSHIP DEVELOPMENT; PROMOTING PUBLIC INTEREST IN EDUCATION, RECOGNITION, CAREER ADVANCEMENT, AND LEADERSHIP FOR ELITE MANAGERS AND EXECUTIVES IN CORPORATIONS AND PROFESSIONAL SERVICE FIRMS; PUBLIC ADVOCACY TO PROMOTE AWARENESS OF COMMUNITY COLLEGES; RECRUITMENT OF STUDENTS FOR HIGHER EDUCATION INSTITUTIONS (U.S. CLS. 100, 101 AND 102).

FIRST USE 11-0-1995; IN COMMERCE 11-0-1995.

**CLASS 36—INSURANCE AND FINANCIAL**

FOR CHARITABLE FUND RAISING SERVICES, NAMELY, RAISING FUNDS FOR COLLEGE EDUCATION COSTS; PROVIDING AN ON-LINE SEARCHABLE DATABASE FEATURING EDUCATION GRANTS (U.S. CLS. 100, 101 AND 102).

FIRST USE 11-0-1995; IN COMMERCE 11-0-1995.

**CLASS 41—EDUCATION AND ENTERTAINMENT**

FOR COMPUTER EDUCATION TRAINING; COMPUTER EDUCATION TRAINING SERVICES; CONTINUING EDUCATION SERVICES, NAMELY, PROVIDING LIVE AND ON-LINE CONTINUING PROFESSIONAL EDUCATION SEMINARS IN THE FIELDS OF COLLEGE LEVEL ACADEMIC DISCIPLINES; CONTINUING EDUCATION SERVICES, NAMELY, PROVIDING LIVE AND ON-LINE CONTINUING PROFESSIONAL EDUCATION SEMINARS IN THE LEGAL, MEDICAL, ACCOUNTING, AND REAL ESTATE FIELDS; EDUCATION COURSES RELATING TO THE TRAVEL INDUSTRY; EDUCATION IN THE FIELD OF COLLEGE LEVEL ACADEMIC DISCIPLINES RENDERED THROUGH CORRESPONDENCE COURSES; EDUCATION IN THE FIELD OF COLLEGE LEVEL ACADEMIC DISCIPLINES RENDERED THROUGH VIDEO CONFERENCE; EDUCATION INFORMATION; EDUCATION SERVICES IN THE NATURE OF COURSES AT THE UNIVERSITY LEVEL; EDUCATION SERVICES IN THE NATURE OF EARLY CHILDHOOD INSTRUCTION; EDUCATION SERVICES, NAMELY, MENTORING IN THE FIELD OF COLLEGE LEVEL ACADEMIC DISCIPLINES; EDUCATION SERVICES, NAMELY, ONE-ON-ONE MENTORING IN THE FIELD OF COLLEGE LEVEL ACADEMIC DISCIPLINES; EDUCATION SERVICES, NAMELY, PROVIDING CLASSES AND INSTRUCTION IN THE FIELD OF DANCE; EDUCATION SERVICES, NAMELY, PROVIDING LIVE AND ON-LINE CLASSES, SEMINARS, WORKSHOPS, CONFERENCES IN THE FIELD OF COLLEGE LEVEL ACADEMIC DISCIPLINES; EDUCATION SERVICES, NAMELY, PROVIDING MENTORING, TUTORING, CLASSES, SEMINARS AND WORKSHOPS IN THE FIELD OF COLLEGE LEVEL ACADEMIC DISCIPLINES; EDUCATION SERVICES, NAMELY, PROVIDING ON-LINE CLASSES, SEMINARS, WORKSHOPS, CONFERENCES IN THE FIELD OF COLLEGE LEVEL ACADEMIC DISCIPLINES; EDUCATION SERVICES, NAMELY, PROVIDING TUTORIAL SESSIONS IN THE FIELD(S) OF COLLEGE LEVEL ACADEMIC DISCIPLINES; EDUCATION SERVICES, NAMELY, PROVIDING TUTORING IN THE FIELD OF COLLEGE LEVEL ACADEMIC DISCIPLINES; EDUCATION SERVICES, NAMELY, PROVIDING CLASSROOM AND ONLINE SEMINARS, CLASSES, WORKSHOPS, CONFERENCES IN THE FIELDS OF COLLEGE LEVEL ACADEMIC DISCIPLINES; EDUCATION SERVICES, NAMELY, TRAINING EDUCATORS TO TEACH THROUGH SERVICE LEARNING AND CIVIC ENGAGEMENT AND PROVIDING CURRICULA IN CONNECTION THEREWITH; EDUCATIONAL COUNSELING SERVICES TO ASSIST STUDENTS IN PLANNING AND PREPARING FOR FURTHER EDUCATION; EDUCATIONAL SERVICES, NAMELY, PROVIDING CONTINUING PROFESSIONAL EDUCATION COURSES IN THE FIELD OF COLLEGE LEVEL ACADEMIC DISCIPLINES; EDUCATIONAL SERVICES, NAMELY, THE OFFERING OF WEB BASED AND CLASSROOM TRAINING FOR CERTIFICATION OF TEACHERS AND CONTINUING EDUCATION FOR TEACHERS AND PRINCIPALS; ENTERTAINMENT AND EDUCATION SERVICES IN THE NATURE OF LIVE DANCE AND MUSICAL PERFORMANCES; INFORMATION ABOUT EDUCATION; INFORMATION IN THE FIELD OF PARENTING CONCERNING EDUCATION OF CHILDREN; INFORMATION ON EDUCATION; INFORMATION RELATING TO ENTERTAINMENT AND EDUCATION, PROVIDED ON-LINE FROM A COMPUTER DATABASE OR THE INTERNET; ORGANIZING LIVE EXHIBITIONS AND CONFERENCES IN THE FIELDS OF EDUCATION, CULTURE, SPORTS AND ENTERTAINMENT FOR NON-BUSINESS AND NON-COMMERCIAL PURPOSES; PHYSICAL EDUCATION; PHYSICAL EDUCATION SERVICES; PROVIDING A WEB SITE THAT FEATURES INFORMATION ABOUT ONLINE HIGHER EDUCATION RESOURCES; PROVIDING A WEBSITE FEATURING EDUCATION AND ENTERTAINMENT FOR CHILDREN;

PROVIDING CONTINUING BUSINESS EDUCATION COURSES; PROVIDING CONTINUING LEGAL EDUCATION COURSES; PROVIDING CONTINUING NURSING EDUCATION COURSES; PROVIDING INFORMATION AND NEWS IN THE FIELD OF TEACHING METHODOLOGY AND EDUCATION; PROVIDING INFORMATION ON TEACHING METHODOLOGY AND EDUCATION ISSUES TO MUSIC EDUCATORS; PROVISION OF INFORMATION IN THE FIELD OF CHILDREN'S EDUCATION; VOCATIONAL EDUCATION IN THE FIELDS OF AUTOMOTIVE, WELDING, PARALEGAL, CULINARY (U.S. CLS. 100, 101 AND 107).

FIRST USE 11-0-1995; IN COMMERCE 11-0-1995.

BRIAN PINO, EXAMINING ATTORNEY

---

SN 77-910,465. SANTA CLARITA COMMUNITY COLLEGE DISTRICT, SANTA CLARITA, CA. FILED 1-12-2010.



NO CLAIM IS MADE TO THE EXCLUSIVE RIGHT TO USE "COLLEGE" OR "SANTA CLARITA COMMUNITY COLLEGE DISTRICT", APART FROM THE MARK AS SHOWN.

THE MARK CONSISTS OF TWO LINES AT AN ANGLE TO THE LEFT OF A TRIANGLE ABOVE A MIRROR IMAGE OF THIS SAME DESIGN ALL ENCLOSED WITHIN A CIRCULAR BORDER BEARING THE WORDS "SANTA CLARITA COMMUNITY COLLEGE DISTRICT COLLEGE OF THE CANYONS".

**CLASS 35—ADVERTISING AND BUSINESS**

FOR CONSULTING SERVICES IN THE FIELD OF HIGHER EDUCATION ADMINISTRATION; EDUCATION LEADERSHIP DEVELOPMENT; PROMOTING PUBLIC INTEREST IN EDUCATION, RECOGNITION, CAREER ADVANCEMENT, AND LEADERSHIP FOR ELITE MANAGERS AND EXECUTIVES IN CORPORATIONS AND PROFESSIONAL SERVICE FIRMS; PUBLIC ADVOCACY TO PROMOTE AWARENESS OF COMMUNITY COLLEGES; RECRUITMENT OF STUDENTS FOR HIGHER EDUCATION INSTITUTIONS (U.S. CLS. 100, 101 AND 102).

FIRST USE 8-27-2007; IN COMMERCE 8-27-2007.

**CLASS 36—INSURANCE AND FINANCIAL**

FOR CHARITABLE FUND RAISING SERVICES, NAMELY, RAISING FUNDS FOR COLLEGE EDUCATION COSTS; PROVIDING AN ON-LINE SEARCHABLE DATABASE FEATURING EDUCATION GRANTS (U.S. CLS. 100, 101 AND 102).

FIRST USE 8-27-2007; IN COMMERCE 8-27-2007.

**CLASS 41—EDUCATION AND ENTERTAINMENT**

FOR COMPUTER EDUCATION TRAINING; COMPUTER EDUCATION TRAINING SERVICES; CONTINUING EDUCATION SERVICES, NAMELY, PROVIDING LIVE AND ON-LINE CONTINUING PROFESSIONAL EDUCATION SEMINARS IN THE FIELDS OF COLLEGE LEVEL ACADEMIC DISCIPLINES; CONTINUING EDUCATION SERVICES, NAMELY, PROVIDING LIVE AND ON-LINE CONTINUING PROFESSIONAL EDUCATION SEMINARS IN THE LEGAL, MEDICAL, ACCOUNTING, AND REAL ESTATE FIELDS; EDUCATION COURSES RELATING TO THE TRAVEL INDUSTRY; EDUCATION IN THE FIELD OF COLLEGE LEVEL ACADEMIC DISCIPLINES RENDERED THROUGH CORRESPONDENCE COURSES; EDUCATION IN THE FIELD OF COLLEGE LEVEL ACADEMIC DISCIPLINES RENDERED THROUGH VIDEO CONFERENCE; EDUCATION INFORMATION; EDUCATION SERVICES IN THE NATURE OF COURSES AT THE UNIVERSITY LEVEL; EDUCATION SERVICES IN THE NATURE OF EARLY CHILDHOOD INSTRUCTION; EDUCATION SERVICES, NAMELY, MENTORING IN THE FIELD OF COLLEGE LEVEL ACADEMIC DISCIPLINES; EDUCATION SERVICES, NAMELY, ONE-ON-ONE MENTORING IN THE FIELD OF COLLEGE LEVEL ACADEMIC DISCIPLINES; EDUCATION SERVICES, NAMELY, PROVIDING CLASSES AND INSTRUCTION IN THE FIELD OF DANCE; EDUCATION SERVICES, NAMELY, PROVIDING LIVE AND ON-LINE CLASSES, SEMINARS, WORKSHOPS, CONFERENCES IN THE FIELD OF COLLEGE LEVEL ACADEMIC DISCIPLINES; EDUCATION SERVICES, NAMELY, PROVIDING MENTORING, TUTORING, CLASSES, SEMINARS AND WORKSHOPS IN THE FIELD OF COLLEGE LEVEL ACADEMIC DISCIPLINES; EDUCATION SERVICES, NAMELY, PROVIDING ON-LINE CLASSES, SEMINARS, WORKSHOPS, CONFERENCES IN THE FIELD OF COLLEGE LEVEL ACADEMIC DISCIPLINES; EDUCATION SERVICES, NAMELY, PROVIDING TUTORIAL SESSIONS IN THE FIELD(S) OF COLLEGE LEVEL ACADEMIC DISCIPLINES; EDUCATION SERVICES, NAMELY, PROVIDING TUTORING IN THE FIELD OF COLLEGE LEVEL ACADEMIC DISCIPLINES; EDUCATION SERVICES, NAMELY, PROVIDING CLASSROOM AND ONLINE SEMINARS, CLASSES, WORKSHOPS, CONFERENCES IN THE FIELDS OF COLLEGE LEVEL ACADEMIC DISCIPLINES; EDUCATION SERVICES, NAMELY, TRAINING EDUCATORS TO TEACH THROUGH SERVICE LEARNING AND CIVIC ENGAGEMENT AND PROVIDING CURRICULA IN CONNECTION THEREWITH; EDUCATIONAL COUNSELING SERVICES TO ASSIST STUDENTS IN PLANNING AND PREPARING FOR FURTHER EDUCATION; EDUCATIONAL SERVICES, NAMELY, PROVIDING CONTINUING PROFESSIONAL EDUCATION COURSES IN THE FIELD OF COLLEGE LEVEL ACADEMIC DISCIPLINES; EDUCATIONAL SERVICES, NAMELY, THE OFFERING OF WEB BASED AND CLASSROOM TRAINING FOR CERTIFICATION OF TEACHERS AND CONTINUING EDUCATION FOR TEACHERS AND PRINCIPALS; ENTERTAINMENT AND EDUCATION SERVICES IN THE NATURE OF LIVE DANCE AND MUSICAL PERFORMANCES; INFORMATION ABOUT EDUCATION; INFORMATION IN THE FIELD OF PARENTING CONCERNING EDUCATION OF CHILDREN; INFORMATION ON EDUCATION; INFORMATION RELATING TO ENTERTAINMENT AND EDUCATION, PROVIDED ON-LINE FROM A COMPUTER DATABASE OR THE INTERNET; ORGANIZING LIVE EXHIBITIONS AND CONFERENCES IN THE FIELDS OF EDUCATION, CULTURE, SPORTS AND ENTERTAINMENT FOR NON-BUSINESS AND NON-COMMERCIAL PURPOSES; PHYSICAL EDUCATION; PHYSICAL EDUCATION SERVICES; PROVIDING A WEB SITE THAT FEATURES INFORMATION ABOUT ONLINE HIGHER EDUCATION RESOURCES; PROVIDING A WEBSITE FEATURING EDUCATION AND ENTERTAINMENT FOR CHILDREN; PROVIDING CONTINUING BUSINESS EDUCATION COURSES; PROVIDING CONTINUING LEGAL EDUCATION COURSES; PROVIDING CONTINUING NURSING EDUCATION COURSES; PROVIDING INFORMATION AND NEWS IN THE FIELD OF TEACHING METHODOLOGY AND EDUCATION; PROVIDING INFORMATION ON TEACHING METHODOLOGY AND EDUCATION ISSUES TO MUSIC EDUCATORS; PROVISION OF INFORMATION IN THE FIELD OF CHIL-

DREN'S EDUCATION; VOCATIONAL EDUCATION IN THE FIELDS OF AUTOMOTIVE, WELDING, PARALEGAL, CULINARY (U.S. CLS. 100, 101 AND 107).  
FIRST USE 8-27-2007; IN COMMERCE 8-27-2007.  
BRIAN PINO, EXAMINING ATTORNEY

SN 77-915,530. ANUE SYSTEMS, INC., AUSTIN, TX. FILED 1-20-2010.



THE MARK CONSISTS OF THE WORD "ANUE" SURROUNDED BY AN OVAL DESIGN.  
THE ENGLISH TRANSLATION OF "ANUE" IN THE MARK IS "RAINBOW".

**CLASS 9—ELECTRICAL AND SCIENTIFIC APPARATUS**

FOR COMPUTER HARDWARE AND SOFTWARE FOR TESTING AND MONITORING NETWORKS, APPLICATIONS BEING RUN ON THOSE NETWORKS, AND NETWORKING EQUIPMENT; COMPUTER HARDWARE AND SOFTWARE FOR SETTING UP AND CONFIGURING NETWORKS; COMPUTER HARDWARE AND SOFTWARE FOR NETWORK IMPAIRMENT EMULATION; COMPUTER HARDWARE AND SOFTWARE FOR TESTING AND MEASURING NETWORK IMPAIRMENT LEVELS; COMPUTER HARDWARE AND SOFTWARE FOR PROVIDING SECURITY TO NETWORKS; COMPUTER HARDWARE AND SOFTWARE TO IMPROVE THE PERFORMANCE OF NETWORKS; COMPUTER HARDWARE AND SOFTWARE FOR TROUBLESHOOTING ISSUES ON NETWORKS; COMPUTER HARDWARE AND SOFTWARE TO PROVIDE ACCESS TO MONITOR NETWORKS (U.S. CLS. 21, 23, 26, 36 AND 38).

**CLASS 42—SCIENTIFIC AND COMPUTER SERVICES**

FOR COMPUTER HARDWARE AND SOFTWARE CONSULTING SERVICES; CONSULTING SERVICES IN THE FIELD OF DESIGN, SELECTION, IMPLEMENTATION AND USE OF COMPUTER HARDWARE AND SOFTWARE SYSTEMS FOR OTHERS; COMPUTER SYSTEMS ANALYSIS; PROFESSIONAL COMPUTER SERVICES, NAMELY, NETWORK ANALYSIS, LAN/WAN DESIGN, WIRELESS ENGINEERING, VIRTUALIZATION AND COMPUTER PROJECT MANAGEMENT; MONITORING THE COMPUTER SYSTEMS OF OTHERS FOR TECHNICAL PURPOSES; TECHNICAL CONSULTING AND ASSISTANCE WITH COMPUTER-BASED INFORMATION SYSTEMS AND COMPONENTS; TECHNICAL SUPPORT SERVICES, NAMELY, TROUBLESHOOTING OF COMPUTER NETWORK, HARDWARE AND SOFTWARE PROBLEMS; TECHNICAL CONSULTING TO HELP COMPANIES SECURE THEIR NETWORKS; TECHNICAL CONSULTING TO HELP COMPANIES IMPROVE THE PERFORMANCE OF THE NETWORKS; TECHNICAL CONSULTING TO HELP COMPANIES KEEP THE OPERATIONS COMPLIANT WITH REGULATORY REQUIREMENTS (U.S. CLS. 100 AND 101).

SCOTT BIBB, EXAMINING ATTORNEY

SN 77-923,305. MYSCHOOLSTREAMS, LLC, PONTE VEDRA BEACH, FL. FILED 1-29-2010.

planetHS

THE MARK CONSISTS OF STANDARD CHARACTERS WITHOUT CLAIM TO ANY PARTICULAR FONT, STYLE, SIZE, OR COLOR.

#### CLASS 38—COMMUNICATION

FOR STREAMING OF VIDEO MATERIAL ON THE INTERNET (U.S. CLS. 100, 101 AND 104).  
FIRST USE 11-29-2009; IN COMMERCE 11-29-2009.

#### CLASS 42—SCIENTIFIC AND COMPUTER SERVICES

FOR HOSTING AN ONLINE WEBSITE FEATURING ORGANIZATION SPECIFIC WEB PAGES THAT INCLUDE CALENDARS, PHOTOS, CURRENT EVENTS, VIDEOS, DOCUMENTS AND OTHER INFORMATION, AS WELL AS LIVE STREAMING OF ORGANIZATIONAL SPORTS, ARTS AND ORGANIZATION RELATED EVENTS (U.S. CLS. 100 AND 101).  
FIRST USE 11-29-2009; IN COMMERCE 11-29-2009.  
THOMAS MANOR, EXAMINING ATTORNEY

SN 77-923,489. NEC BIGLOBE, LTD., TOKYO, JAPAN, FILED 1-29-2010.

ANDRONAVI

THE MARK CONSISTS OF STANDARD CHARACTERS WITHOUT CLAIM TO ANY PARTICULAR FONT, STYLE, SIZE, OR COLOR.

#### CLASS 35—ADVERTISING AND BUSINESS

FOR ONLINE RETAIL STORE SERVICES FEATURING DOWNLOADABLE SOUND, MUSIC, IMAGE, VIDEO AND MULTIMEDIA CONTENT PROVIDED VIA THE INTERNET AND OTHER COMPUTER AND ELECTRONIC COMMUNICATION NETWORKS; ONLINE RETAIL STORE SERVICES FEATURING DOWNLOADABLE COMPUTER APPLICATION SOFTWARE; PROMOTING THE GOODS AND SERVICES OF OTHERS BY PROVIDING ONLINE CONSUMER PRODUCT REVIEWS OF MOBILE PHONES, MOBILE HAND HELD DEVICES, PORTABLE HAND HELD DEVICES, DIGITAL HAND HELD DEVICES AND COMPUTER APPLICATION SOFTWARE; PROVIDING ONLINE CONSUMER INFORMATION AND RELATED NEWS IN THE FIELD OF MOBILE PHONES, MOBILE HAND HELD DEVICES, PORTABLE HAND HELD DEVICES, DIGITAL HAND HELD DEVICES AND COMPUTER APPLICATION SOFTWARE (U.S. CLS. 100, 101 AND 102).

#### CLASS 42—SCIENTIFIC AND COMPUTER SERVICES

FOR HOSTING OF COMPUTER WEBSITES; HOSTING OF DIGITAL CONTENT APPLICABLE FOR MOBILE PHONES, MOBILE HAND HELD DEVICES, PORTABLE HAND HELD DEVICES AND DIGITAL HANDHELD DEVICES VIA THE INTERNET AND OTHER COMPUTER AND ELECTRONIC COMMUNICATION NETWORKS; PROVIDING TEMPORARY USE OF NON-DOWNLOADABLE COMPUTER APPLICATION SOFTWARE FOR VIEWING, SEARCHING AND BROWSING TEXT, AUDIO, VISUAL AND MULTIMEDIA DATA AND CONTENT FOR MOBILE PHONES, CELLULAR PHONES, SMART PHONES, MOBILE HAND HELD DEVICES, PORTABLE HAND HELD DEVICES AND DIGITAL HAND HELD DEVICES (U.S. CLS. 100 AND 101).

LINDA ORNDORFF, EXAMINING ATTORNEY

SN 77-927,976. SUSTAINET ENTERPRISES INC., VANCOUVER, BC, CANADA, FILED 2-4-2010.

SUSTAINET

THE MARK CONSISTS OF STANDARD CHARACTERS WITHOUT CLAIM TO ANY PARTICULAR FONT, STYLE, SIZE, OR COLOR.

PRIORITY CLAIMED UNDER SEC. 44(D) ON CANADA APPLICATION NO. 1468221, FILED 2-3-2010, REG. NO. TMA788913, DATED 1-27-2011, EXPIRES 1-27-2026.

#### CLASS 9—ELECTRICAL AND SCIENTIFIC APPARATUS

FOR SOFTWARE FOR USE IN MANAGING INFORMATION FOR CORPORATE SOCIAL RESPONSIBILITY AND CORPORATE SUSTAINABILITY GOALS, NAMELY, STAKEHOLDER INFORMATION MANAGEMENT, STAKEHOLDER DATA MANAGEMENT, ENVIRONMENTAL INFORMATION MANAGEMENT, ENVIRONMENTAL DATA MANAGEMENT, CORPORATE CHANGE MANAGEMENT, ISSUES MANAGEMENT, RISK MANAGEMENT, TASK MANAGEMENT, COMMITMENTS MANAGEMENT, MEETINGS MANAGEMENT, RECORDS MANAGEMENT, ISSUES RESOLUTION MANAGEMENT, STAKEHOLDER AND CUSTOMER CONTACT MANAGEMENT, DATA VISUALIZATION OF GEOGRAPHIC INFORMATION AND COMPLIMENTARY MODULES THAT RELATE TO ONLINE AND OFFLINE COMMUNITY ENGAGEMENT AND PUBLIC CONSULTATION (U.S. CLS. 21, 23, 26, 36 AND 38).

#### CLASS 35—ADVERTISING AND BUSINESS

FOR ONLINE RETAIL AND ENTERPRISE-TO-ENTERPRISE STORE SERVICES FEATURING THIRD PARTY SOFTWARE FOR USE IN MANAGING INFORMATION FOR CORPORATE SOCIAL RESPONSIBILITY AND CORPORATE SUSTAINABILITY GOALS (U.S. CLS. 100, 101 AND 102).

#### CLASS 41—EDUCATION AND ENTERTAINMENT

FOR TRAINING IN THE PROPER USE OF SOFTWARE FOR USE IN MANAGING INFORMATION FOR CORPORATE SOCIAL RESPONSIBILITY AND CORPORATE SUSTAINABILITY GOALS (U.S. CLS. 100, 101 AND 107).

**CLASS 42—SCIENTIFIC AND COMPUTER SERVICES**

FOR TECHNOLOGY CONSULTING IN THE FIELD OF MANAGING INFORMATION FOR CORPORATE SOCIAL RESPONSIBILITY AND CORPORATE SUSTAINABILITY GOALS; DESIGNING AND IMPLEMENTING SOFTWARE FOR USE IN MANAGING INFORMATION FOR CORPORATE SOCIAL RESPONSIBILITY AND CORPORATE SUSTAINABILITY GOALS; PROFESSIONAL SUPPORT, NAMELY, TROUBLESHOOTING OF SOFTWARE PROBLEMS IN THE FIELD OF SOFTWARE FOR USE IN MANAGING INFORMATION FOR CORPORATE SOCIAL RESPONSIBILITY AND CORPORATE SUSTAINABILITY GOALS (U.S. CLS. 100 AND 101).

DOUGLAS LEE, EXAMINING ATTORNEY

SN 77-931,281. AMIRA FOODS (INDIA) LTD., MEHRAULI, NEW DELHI, INDIA, FILED 2-9-2010.

# SATIVA

THE MARK CONSISTS OF STANDARD CHARACTERS WITHOUT CLAIM TO ANY PARTICULAR FONT, STYLE, SIZE, OR COLOR.

**CLASS 29—MEATS AND PROCESSED FOODS**

FOR MEAT, FISH, POULTRY AND GAME, MEAT EXTRACTS; EDIBLE OILS AND FATS; FRUIT PRESERVES AND PICKLES; PRESERVED, DRIED AND COOKED FRUITS AND VEGETABLES, JELLIES, JAMS, MILK AND OTHER DAIRY PRODUCTS EXCLUDING ICE CREAM, ICE MILK AND FROZEN YOGURT (U.S. CL. 46).

**CLASS 30—STAPLE FOODS**

FOR COFFEE, TEA, COCOA, SUGAR, RICE, TAPIOCA, SAGO, ARTIFICIAL COFFEE, FLOUR, PREPARATIONS MADE FROM CEREALS, NAMELY, SNACK FOODS; PUFFED RICE, RICE FLOUR, WHOLE MEAL RICE, STARCH RICE FLOUR, ENRICHED COOKED RICE, CEREAL BASED SNACK FOODS, CONFECTIONERY, NAMELY, CHOCOLATE, CONFECTIONERY CHIPS FOR BAKING, CONFECTIONERY MADE OF SUGAR; CONFECTIONERY, NAMELY, PASTILLES, FONDANTS, CRYSTAL SUGAR PIECES (U.S. CL. 46).

MAUREEN DALL, EXAMINING ATTORNEY

SN 77-928,047. THE INTERNATIONAL PEDIATRIC NUTRITION ALLIANCE, LLC, ST. LOUIS, MO. FILED 2-4-2010.

## GLOBAL HARVEST ALLIANCE

THE MARK CONSISTS OF STANDARD CHARACTERS WITHOUT CLAIM TO ANY PARTICULAR FONT, STYLE, SIZE, OR COLOR.

NO CLAIM IS MADE TO THE EXCLUSIVE RIGHT TO USE "GLOBAL" AND "ALLIANCE", APART FROM THE MARK AS SHOWN.

**CLASS 36—INSURANCE AND FINANCIAL**

FOR (BASED ON INTENT TO USE) CHARITABLE FUNDRAISING SERVICES (U.S. CLS. 100, 101 AND 102).

**CLASS 41—EDUCATION AND ENTERTAINMENT**

FOR (BASED ON INTENT TO USE) EDUCATIONAL SERVICES, NAMELY, CONDUCTING CONFERENCES, SEMINARS, AND WEBINARS VIA THE INTERNET IN THE FIELDS OF AGRICULTURE, MEDICINE AND PLANT SCIENCES TO DEVELOP SOLUTIONS TO ERADICATE CHILDHOOD HUNGER AND MALNUTRITION (U.S. CLS. 100, 101 AND 107).

**CLASS 42—SCIENTIFIC AND COMPUTER SERVICES**

FOR (BASED ON USE IN COMMERCE) SCIENTIFIC RESEARCH IN THE FIELDS OF AGRICULTURE, MEDICINE AND PLANT SCIENCES TO DEVELOP SOLUTIONS TO ERADICATE CHILDHOOD HUNGER AND MALNUTRITION (U.S. CLS. 100 AND 101).

FIRST USE 7-28-2009; IN COMMERCE 7-28-2009.  
AMEEN IMAM, EXAMINING ATTORNEY

SN 77-931,923. INTERNATIONAL INDEX COMPANY LIMITED, LONDON SE1 2AP, UNITED KINGDOM, AND MARKIT NORTH AMERICA INC., NEW YORK, NY. FILED 2-9-2010.

# SOVX

THE MARK CONSISTS OF STANDARD CHARACTERS WITHOUT CLAIM TO ANY PARTICULAR FONT, STYLE, SIZE, OR COLOR.



**CLASS 9—ELECTRICAL AND SCIENTIFIC APPARATUS**

FOR COMPUTER SOFTWARE FOR USE IN THE FINANCIAL SERVICES FIELD AND FOR FINANCIAL AND BUSINESS INFORMATION, NAMELY, FOR ACCESSING BUSINESS, COMMERCIAL AND FINANCIAL NEWS, INFORMATION AND DATA; COMPUTER HARDWARE; COMPUTER FIRMWARE FOR USE IN THE FIELD OF FINANCIAL AND BUSINESS INFORMATION, NAMELY, FOR ACCESSING BUSINESS, COMMERCIAL AND FINANCIAL NEWS, INFORMATION AND DATA; COMPUTER SOFTWARE AND DOWNLOADABLE COMPUTER SOFTWARE FOR DATA PROCESSING; COMPUTER PROGRAMMING APPARATUS, NAMELY, COMPUTER SOFTWARE FOR COMPUTER PROGRAMMING FOR USE IN THE FIELD OF FINANCIAL AND BUSINESS INFORMATION; APPLICATION PROGRAMMING APPARATUS, NAMELY, COMPUTER SOFTWARE FOR APPLICATION PROGRAMMING FOR USE IN THE FIELD OF FINANCIAL AND BUSINESS INFORMATION; COMPUTER SOFTWARE AND COMPUTER SOFTWARE APPLICATIONS FOR USE IN PROCESSING FINANCIAL AND BANKING INFORMATION AND DATA; APPARATUS FOR RECORDING, TRANSMISSION OR REPRODUCTION OF SOUND OR IMAGES; DATA PROCESSING EQUIPMENT; COMPUTERS; COMPUTER SOFTWARE DEVELOPMENT TOOLS; DOWNLOADABLE ELECTRONIC NEWSLETTERS IN THE FIELD OF FINANCIAL NEWS AND INFORMATION; DOWNLOADABLE ELECTRONIC FINANCIAL AND BUSINESS INFORMATION DATA FILES VIA THE INTERNET AND WIRELESS DEVICES; COMPUTER HARDWARE AND COMPUTER SOFTWARE FOR DATABASE MANAGEMENT; COMPUTER PROGRAMS FOR USE IN THE FINANCIAL AND BUSINESS SERVICES FIELD, NAMELY, FOR ACCESSING BUSINESS, COMMERCIAL AND FINANCIAL NEWS, INFORMATION AND DATA; DOWNLOADABLE ELECTRONIC PUBLICATIONS IN THE FORM OF NEWSLETTERS AND INFORMATION SHEETS IN THE FIELD OF FINANCIAL AND BUSINESS INFORMATION; INTERACTIVE COMPUTER SOFTWARE FOR USE IN THE FINANCIAL AND BUSINESS SERVICES FIELD, NAMELY, FOR ACCESSING BUSINESS, COMMERCIAL AND FINANCIAL NEWS, INFORMATION AND DATA; COMPUTER SEARCH ENGINE SOFTWARE (U.S. CLS. 21, 23, 26, 36 AND 38).

**CLASS 35—ADVERTISING AND BUSINESS**

FOR PROVIDING BUSINESS AND COMMERCIAL INFORMATION FOR USE IN THE FINANCIAL AND BUSINESS SERVICES FIELD; COMPILATION AND SYSTEMIZATION OF INFORMATION INTO COMPUTER DATABASES; BUSINESS INVESTIGATIONS; ECONOMIC FORECASTING; BUSINESS RESEARCH; PROVIDING STATISTICAL INFORMATION FOR BUSINESS OR COMMERCIAL PURPOSES; BUSINESS DATA ANALYSIS; DATABASE MANAGEMENT; COLLECTION, PREPARATION, COMPILATION, PROCESSING, PROVISION AND MANAGEMENT OF BUSINESS DATA; PROVIDING A COMPUTER DATABASE IN THE FIELD OF BUSINESS INFORMATION (U.S. CLS. 100, 101 AND 102).

**CLASS 36—INSURANCE AND FINANCIAL**

FOR PROVIDING FINANCIAL INFORMATION AND DATA; THE PROVISION OF FINANCIAL INFORMATION; PROVIDING ONLINE FINANCIAL AND BANKING INFORMATION AND DATA VIA A GLOBAL COMPUTER NETWORK; PROVIDING A WEBSITE FEATURING FINANCIAL NEWS, INFORMATION AND DATA; FINANCIAL MANAGEMENT; FINANCIAL ANALYSES; FINANCIAL INFORMATION AND ADVISORY SERVICES; STOCK EXCHANGE PRICE QUOTATION; STOCK EXCHANGE INFORMATION SERVICES; ELECTRONIC TRADE PROCESSING SERVICES, NAMELY, ELECTRONIC FINANCIAL TRADING SERVICES; PROVIDING INFORMATION AND DATA RELATING TO SECURITIES PRICING, EQUITIES PRICING, CREDIT PRICING, CREDIT MARKET PRICING, FINANCIAL INSTRUMENT PRICE DISCREPANCY, PRICE DISCREPANCY, INDIVIDUAL AND SECTOR CREDIT CURVE CONSTRUCTION, CREDIT CURVES, AND FINANCIAL INSTRUMENT PRICES; FINANCIAL RESEARCH AND INFORMATION SERVICES, NAMELY, COLLECTING,

VERIFYING, ORGANIZING, MANAGING, PROCESSING AND PROVIDING INFORMATION FOR USE IN FINANCIAL RISK MANAGEMENT, FINANCIAL RISK MITIGATION, CREDIT RISK MANAGEMENT AND FINANCIAL TRADING; FACILITATING, PROCESSING AND COMPLETING TRANSACTIONS FOR AND TRADES OF SECURITIES; FINANCIAL NEWS REPORTING SERVICES; PROVIDING A COMPUTER DATABASE IN THE FIELD OF FINANCIAL SERVICES; PROVIDING ON-LINE COMPUTER DATABASE IN THE FIELD OF FINANCIAL SERVICES, NAMELY, FINANCIAL ADVISORY AND CONSULTANCY SERVICES (U.S. CLS. 100, 101 AND 102).

**CLASS 38—COMMUNICATION**

FOR PROVIDING ACCESS TO DATABASES CONTAINING ONLINE FINANCIAL AND BANKING INFORMATION, FINANCIAL NEWS, SECURITIES PRICING, EQUITIES PRICING, CREDIT PRICING, CREDIT MARKET PRICING, FINANCIAL INSTRUMENT PRICE DISCREPANCY, PRICE DISCREPANCY, INDIVIDUAL AND CREDIT CURVE CONSTRUCTION, CREDIT CURVES, FINANCIAL INSTRUMENT PRICES, SYNDICATED LOANS, AND INFORMATION AND ANALYSIS REGARDING FINANCIAL MARKETS, FISCAL ASSESSMENTS AND STOCK EXCHANGE QUOTATIONS; PROVIDING ACCESS TO DATABASES CONTAINING FINANCIAL AND BUSINESS INFORMATION; PROVISION OF TELECOMMUNICATION SERVICES FOR THE TRANSMISSION OF ELECTRONIC FINANCIAL DATA DISPLAY AND FILES (U.S. CLS. 100, 101 AND 104).

**CLASS 41—EDUCATION AND ENTERTAINMENT**

FOR PROVIDING NON-DOWNLOADABLE ELECTRONIC PUBLICATIONS, NAMELY, NEWSLETTERS IN THE FIELDS OF FINANCIAL AND BUSINESS NEWS AND INFORMATION; PROVIDING ONLINE ELECTRONIC PUBLICATIONS, NAMELY, NEWSLETTERS IN THE FIELDS OF FINANCIAL AND BUSINESS NEWS AND INFORMATION (U.S. CLS. 100, 101 AND 107).

**CLASS 42—SCIENTIFIC AND COMPUTER SERVICES**

FOR PROVIDING TEMPORARY USE OF ONLINE NON-DOWNLOADABLE COMPUTER SOFTWARE FOR PROCESSING FINANCIAL AND BANKING TRANSACTIONS; PROVIDING TEMPORARY USE OF ONLINE NON-DOWNLOADABLE COMPUTER SOFTWARE FOR USE IN THE FINANCIAL SERVICES FIELD, NAMELY, FOR ACCESSING BUSINESS, COMMERCIAL AND FINANCIAL NEWS, INFORMATION AND DATA; PROVIDING TEMPORARY USE OF ONLINE NON-DOWNLOADABLE COMPUTER SOFTWARE FOR USE IN THE FINANCIAL SERVICES FIELD, NAMELY, FOR ACCESSING FINANCIAL-RELATED BUSINESS RESEARCH; PROVIDING TEMPORARY USE OF ONLINE NON-DOWNLOADABLE COMPUTER SOFTWARE FOR ACCESSING INFORMATION AND DATA RELATING TO SECURITIES PRICING, EQUITIES PRICING, CREDIT PRICING, CREDIT MARKET PRICING, FINANCIAL INSTRUMENT PRICE DISCREPANCY, PRICE DISCREPANCY, INDIVIDUAL AND SECTOR CREDIT CURVE CONSTRUCTION, CREDIT CURVES, FINANCIAL INSTRUMENT PRICES, AND SYNDICATED LOANS; RECOVERY OF COMPUTER DATA (U.S. CLS. 100 AND 101).

SHARON MEIER, EXAMINING ATTORNEY

SN 77-932,034. HID GLOBAL CORPORATION, IRVINE, CA.  
FILED 2-9-2010.

JORDAN BAKER, EXAMINING ATTORNEY

### GENUINE HID TECHNOLOGY

THE MARK CONSISTS OF STANDARD CHARACTERS WITHOUT CLAIM TO ANY PARTICULAR FONT, STYLE, SIZE, OR COLOR.

PRIORITY CLAIMED UNDER SEC. 44(D) ON ERPN CMNTY TM OFC APPLICATION NO. 008604217, FILED 10-8-2009, REG. NO. 008604217, DATED 5-27-2010, EXPIRES 10-8-2019.

OWNER OF U.S. REG. NOS. 2,249,625, 3,329,275 AND OTHERS.

NO CLAIM IS MADE TO THE EXCLUSIVE RIGHT TO USE "GENUINE" AND "TECHNOLOGY", APART FROM THE MARK AS SHOWN.

#### CLASS 16—PAPER GOODS AND PRINTED MATTER

FOR PAPER, CARDBOARD AND PRINTED GOODS MADE FROM THESE MATERIALS, NAMELY, CARDS, TICKETS, IDENTITY BADGES, TAGS, STICKERS; PRINTED MATTER, NAMELY, TICKETS, IDENTITY BADGES, TAGS, STICKERS; BROCHURES AND MAGAZINES IN THE FIELD OF SECURITY AND IDENTITY AND ACCESS CONTROL; PRINTED PUBLICATIONS, NAMELY, NEWSLETTERS, MANUALS, MARKETING COLLATERAL IN THE FIELD OF SECURITY AND IDENTITY AND ACCESS CONTROL; BOOKS IN THE FIELD OF SECURITY AND IDENTITY AND ACCESS CONTROL; MATERIALS USED IN ADVERTISING SUCH AS POSTERS, TRANSPARENCIES, MADE OF PAPER AND PLASTIC; BOOKBINDING MATERIAL; PHOTOGRAPHS; STATIONERY; ADHESIVES FOR STATIONERY OR HOUSEHOLD PURPOSES; ARTISTS' MATERIALS, NAMELY, PAPER RIBBONS, STICKERS, ADHESIVES, LAMINATES FOR GRAPHIC DESIGNS; PAINT BRUSHES; TYPEWRITERS; INSTRUCTIONAL AND TEACHING MATERIAL, NAMELY, BROCHURES IN THE FIELD OF SECURITY AND IDENTITY AND ACCESS CONTROL; PRINTERS' TYPE; PRINTING BLOCKS (U.S. CLS. 2, 5, 22, 23, 29, 37, 38 AND 50).

#### CLASS 42—SCIENTIFIC AND COMPUTER SERVICES

FOR SCIENTIFIC AND TECHNOLOGICAL SERVICES AND RESEARCH AND DESIGN RELATING THERETO, ALL IN THE FIELD OF IDENTITY AND SECURITY AND ACCESS CONTROL; INDUSTRIAL ANALYSIS AND RESEARCH SERVICES IN THE FIELD OF IDENTITY AND SECURITY AND ACCESS CONTROL; DESIGN AND DEVELOPMENT OF COMPUTER HARDWARE AND SOFTWARE; DESIGN AND DEVELOPMENT OF RADIO FREQUENCY IDENTIFICATION (RFID) SYSTEMS; COMPUTER SYSTEM DESIGN; COMPUTER RENTAL; QUALITY CONTROL SERVICES FOR OTHERS; CERTIFICATION OF PROCEDURES AND APPARATUS, VIA TESTING, ANALYSIS, AND EVALUATION OF THE GOODS AND SERVICES OF OTHERS, FOR PURPOSE OF CERTIFICATION; RENTAL OF ELECTRONIC DEVICE HARDWARE, NAMELY, RENTAL OF RADIO FREQUENCY IDENTIFICATION (RFID) SYSTEM; COMPUTER SOFTWARE DESIGN, INSTALLATION OF COMPUTER SOFTWARE; MAINTENANCE OF COMPUTER SOFTWARE; TECHNICAL RESEARCH IN THE FIELD OF IDENTITY AND SECURITY AND ACCESS CONTROL; MATERIAL TESTING; DATABASE SERVICES, NAMELY, DEVELOPMENT SERVICES, CONFIGURATION AND CUSTOMIZATION OF COMPUTER DATABASE SOFTWARE, KEY MANAGEMENT AND CARD MANAGEMENT; TECHNICAL COMPUTER SERVICES IN THE NATURE OF TROUBLESHOOTING COMPUTER SOFTWARE PROBLEMS AND DIAGNOSING COMPUTER HARDWARE AND SOFTWARE PROBLEMS, ACCESS CONTROL AND SECURITY (U.S. CLS. 100 AND 101).

SN 77-933,126. INNOV8 TRANSPORT INC., AUSTIN, TX.  
FILED 2-10-2010.



THE COLOR(S) DARK GREEN AND LIME GREEN AND BLACK IS/ARE CLAIMED AS A FEATURE OF THE MARK. THE MARK CONSISTS OF THE WORDING "SKYWAY" IN STYLIZED FORM, WITH AN ARROW DESIGN RUNNING FROM LEFT TO RIGHT THROUGH THE LETTERS "SKY" AND ABOVE THE LETTERS "WAY". THE LETTERS "SKY" ARE IN DARK GREEN, THE LETTERS "WAY" ARE IN BLACK, AND THE ARROW IS COMPOSED OF ALTERNATING DARK GREEN AND LIME GREEN.

#### CLASS 6—METAL GOODS

FOR GUIDE-WAYS PRIMARILY OF STEEL THAT ALSO CONTAIN CONCRETE, WHICH ALLOW FOR TRAVEL OF INDIVIDUAL CARS, TRAINS AND FREIGHT TRUCKS WITH BOTH MAGNETIC LEVITATION MOTORS AND THE ABILITY TO DRIVE ON BOTH ROADS AND THE ELECTRIC GUIDE-WAY (U.S. CLS. 2, 12, 13, 14, 23, 25 AND 50).

#### CLASS 19—NON-METALLIC BUILDING MATERIALS

FOR GUIDE-WAYS PRIMARILY OF CONCRETE THAT ALSO CONTAIN STEEL, WHICH ALLOW FOR TRAVEL OF INDIVIDUAL CARS, TRAINS AND FREIGHT TRUCKS WITH BOTH MAGNETIC LEVITATION MOTORS AND THE ABILITY TO DRIVE ON BOTH ROADS AND THE ELECTRIC GUIDE-WAY (U.S. CLS. 1, 12, 33 AND 50).

JANET LEE, EXAMINING ATTORNEY

SN 77-933,251. DIPL.-ING. HERWATH REICH GMBH, BOCHUM, FED REP GERMANY, FILED 2-11-2010.

## Reich Kupplungen

THE MARK CONSISTS OF STANDARD CHARACTERS WITHOUT CLAIM TO ANY PARTICULAR FONT, STYLE, SIZE, OR COLOR.

OWNER OF FED REP GERMANY REG. NO. 30420865, DATED 8-16-2004, EXPIRES 4-30-2014.

NO CLAIM IS MADE TO THE EXCLUSIVE RIGHT TO USE "KUPPLUNGEN", APART FROM THE MARK AS SHOWN.

THE ENGLISH TRANSLATION OF "KUPPLUNGEN" IN THE MARK IS "COUPLINGS".

#### CLASS 7—MACHINERY

FOR COUPLINGS FOR MACHINES, NAMELY, CLAW COUPLINGS, METALLIC COUPLINGS, FLEXIBLE PIN TYPE COUPLINGS, CROWNED TOOTH GEAR COUPLINGS, BARREL COUPLINGS, TYPE COUPLINGS, SHAFT COUPLINGS AND STRUCTURAL PARTS OF THE AFORESAID COUPLINGS (U.S. CLS. 13, 19, 21, 23, 31, 34 AND 35).

**CLASS 12—VEHICLES**

FOR SHAFT COUPLINGS FOR LAND VEHICLES, NAMELY, SHIFTING COUPLINGS, RUBBER DISK COUPLINGS, FLANGE COUPLINGS, SERIES COUPLINGS AND STRUCTURAL PARTS OF THE FORESAID COUPLINGS (U.S. CLS. 19, 21, 23, 31, 35 AND 44).

**CLASS 42—SCIENTIFIC AND COMPUTER SERVICES**

FOR CONSULTING IN THE FIELD OF THE IMPLEMENTATION, DESIGN AND DEVELOPMENT OF NEW PRODUCTS IN THE FIELD OF COUPLING AND DRIVE TECHNOLOGY (U.S. CLS. 100 AND 101).

SETH A. RAPPAPORT, EXAMINING ATTORNEY

SN 77-933,590. LIGHT IN THE NIGHT, LLC, MARIETTA, GA. FILED 2-11-2010.



THE MARK CONSISTS OF A CREATURE AT THE BOTTOM LEFT CORNER OF THE MARK. THE CREATURE HAS A FACE, ARMS, BODY, EYES AND EARS. THE CREATURE IS HOLDING A SIGN IN HIS LEFT HAND WHICH READS "NO MONSTERS" IN CAPITALIZED LETTERS. DIRECTLY BELOW THE WORDS "NO MONSTERS" APPEARS A "NO SYMBOL" IN FRONT OF VARIOUS MONSTERS.

**CLASS 16—PAPER GOODS AND PRINTED MATTER**

FOR CHILDREN'S BOOKS (U.S. CLS. 2, 5, 22, 23, 29, 37, 38 AND 50).

FIRST USE 2-10-2010; IN COMMERCE 2-10-2010.

**CLASS 28—TOYS AND SPORTING GOODS**

FOR PLUSH DOLLS; DOLLS AND CHILDREN'S BOOKS, SOLD AS A UNIT (U.S. CLS. 22, 23, 38 AND 50).

FIRST USE 2-10-2010; IN COMMERCE 2-10-2010.  
KATHLEEN LORENZO, EXAMINING ATTORNEY

SN 77-934,251. CGI TECHNOLOGIES AND SOLUTIONS INC., FAIRFAX, VA. FILED 2-12-2010.

CGI COLLECTIONS360

THE MARK CONSISTS OF STANDARD CHARACTERS WITHOUT CLAIM TO ANY PARTICULAR FONT, STYLE, SIZE, OR COLOR.

OWNER OF U.S. REG. NOS. 3,664,147 AND 3,669,855.

**CLASS 35—ADVERTISING AND BUSINESS**

FOR BUSINESS MANAGEMENT AND CONSULTATION IN THE FIELD OF DEBT COLLECTION; BUSINESS PROCESS OUTSOURCING SERVICES IN THE FIELD OF DEBT COLLECTION; DATA MANAGEMENT SERVICE FOR USE IN REPORTING DEBT COLLECTION ACCOUNTS TO A COLLECTION AGENCY; DATA MANAGEMENT SERVICES FOR USE IN DEBT COLLECTION, NAMELY, ELECTRONIC DATA COLLECTION AND ON-LINE CLAIMS MANAGEMENT; DATA PROCESSING SERVICES (U.S. CLS. 100, 101 AND 102).

**CLASS 42—SCIENTIFIC AND COMPUTER SERVICES**

FOR PROVIDING TEMPORARY USE OF ON-LINE NON-DOWNLOADABLE SOFTWARE FOR USE ON BEHALF OF CREDITORS TO STORE, MANAGE, OBTAIN AND REPORT INFORMATION IN THE FIELD OF DEBT COLLECTION, NEGOTIATION, SETTLEMENT AND ACCOUNTING (U.S. CLS. 100 AND 101).

TIMOTHY FINNEGAN, EXAMINING ATTORNEY

SN 77-934,326. OPUL LLC, LOS ANGELES, CA. FILED 2-12-2010.

OPUL

THE MARK CONSISTS OF STANDARD CHARACTERS WITHOUT CLAIM TO ANY PARTICULAR FONT, STYLE, SIZE, OR COLOR.

**CLASS 35—ADVERTISING AND BUSINESS**

FOR FRANCHISE SERVICES, NAMELY, BUSINESS MANAGEMENT IN THE ESTABLISHMENT AND OPERATION OF RESORTS AND HOTELS; HOTEL MANAGEMENT SERVICES; CUSTOMER LOYALTY PROGRAM SERVICES FOR COMMERCIAL, PROMOTIONAL AND ADVERTISING PURPOSES; MEMBERSHIP CLUB SERVICES, NAMELY, THE MANAGEMENT, PROMOTION, MARKETING, AND BUSINESS OPERATION OF MEMBERSHIP CLUBS THAT PROVIDE MEMBERS ACCESS TO THE USE OF SPA, WELLNESS, FITNESS, ATHLETIC, SOCIAL AND DINING FACILITIES OR EVENTS; REAL ESTATE SALES MANAGEMENT AND REAL ESTATE MARKETING MANAGEMENT; ADVERTISING SERVICES AND PROMOTIONAL SERVICES FOR OTHERS (U.S. CLS. 100, 101 AND 102).

**CLASS 36—INSURANCE AND FINANCIAL**

FOR VACATION REAL ESTATE TIMESHARE SERVICES; REAL ESTATE MANAGEMENT SERVICES; RESIDENTIAL REAL ESTATE AGENCY SERVICES; FINANCIAL EVALUATION, NAMELY, INSURANCE, BANKING AND REAL ESTATE EVALUATION; BROKERAGE SERVICES IN THE FIELDS OF REAL ESTATE, VACATION TIMESHARES AND CLUB MEMBERSHIPS; LENDING CONSULTANT SERVICES (U.S. CLS. 100, 101 AND 102).

**CLASS 37—CONSTRUCTION AND REPAIR**

FOR REAL ESTATE DEVELOPMENT; CONSTRUCTION OF COMMERCIAL, RESIDENTIAL AND HOTEL PROPERTY (U.S. CLS. 100, 103 AND 106).

**CLASS 41—EDUCATION AND ENTERTAINMENT**

FOR HEALTH AND FITNESS TRAINING (U.S. CLS. 100, 101 AND 107).

**CLASS 43—HOTEL AND RESTAURANT SERVICES**

FOR HOTELS; RESORT HOTELS; RESORT LODGING SERVICES; HOTEL SERVICES FOR PREFERRED CUSTOMERS; CATERING SERVICES; CONVENTION, EXHIBITION, EVENT AND MEETING SERVICES, NAMELY, PROVIDING FACILITIES FOR CONVENTIONS, EXHIBITIONS, AND EVENTS; RESTAURANT AND COCKTAIL LOUNGE SERVICES (U.S. CLS. 100 AND 101).

**CLASS 44—MEDICAL, BEAUTY AND AGRICULTURAL SERVICES**

FOR HEALTH SPA SERVICES, NAMELY, FOR HEALTH AND WELLNESS OF THE MIND, BODY AND SPIRIT; COSMETIC BODY CARE SERVICES, MASSAGE, FACIAL AND BODY TREATMENT SERVICES; BODY WRAPS, MUD TREATMENTS, SEAWEED TREATMENTS, HYDROTHERAPY BATHS, AND BODY SCRUBS; LASER TREATMENTS FOR ACNE, REJUVENATION, SCARS, AND TATTOO REMOVAL (U.S. CLS. 100 AND 101).

**CLASS 45—PERSONAL AND LEGAL SERVICES**

FOR CONCIERGE SERVICES FOR OTHERS COMPRISING OF MAKING REQUESTED PERSONAL ARRANGEMENTS AND RESERVATIONS (U.S. CLS. 100 AND 101).

ANDREA HACK, EXAMINING ATTORNEY

SN 77-937,865. SOLOMON MORDECHAI, BUCHAREST, ROMANIA, FILED 2-17-2010.

**GLOBAL EYE INVESTMENTS**

THE MARK CONSISTS OF STANDARD CHARACTERS WITHOUT CLAIM TO ANY PARTICULAR FONT, STYLE, SIZE, OR COLOR.

NO CLAIM IS MADE TO THE EXCLUSIVE RIGHT TO USE "GLOBAL" AND "INVESTMENTS", APART FROM THE MARK AS SHOWN.

**CLASS 35—ADVERTISING AND BUSINESS**

FOR ADVERTISING AND MARKETING FOR ORGANIZATIONS AND ENTERPRISES; MARKET RESEARCH AND MARKET ANALYSIS; FINANCIAL INTERMEDIARY SERVICES, NAMELY, FACILITATING THE CHANNELING OF FUNDS BETWEEN LENDERS AND BORROWERS BY CONNECTING THOSE WITH A FINANCIAL SURPLUS WITH THOSE HAVING A FINANCIAL DEFICIT; NONE OF THE FOREMENTIONED SERVICES RELATING TO THE FIELDS OF MOVING AND RELOCATION OR REAL ESTATE (U.S. CLS. 100, 101 AND 102).

**CLASS 36—INSURANCE AND FINANCIAL**

FOR INSURANCE SERVICES, NAMELY, INSURANCE CONSULTING SERVICES; DEBT COLLECTION SERVICES; FACTORING AGENCY SERVICES; MUTUAL CAPITAL SERVICES, NAMELY, CAPITAL INVESTMENT SERVICES; INVESTMENT MANAGEMENT FOR ORGANIZATIONS AND ENTERPRISES; CONSULTING SERVICES IN THE FIELD OF INVESTMENTS FOR ORGANIZATIONS AND ENTERPRISES; NONE OF THE FOREMENTIONED SERVICES RELATING TO THE FIELDS OF MOVING AND RELOCATION OR REAL ESTATE (U.S. CLS. 100, 101 AND 102).

AMY KERTGATE, EXAMINING ATTORNEY

SN 77-937,939. PANALYTICAL B.V., ALMELO, NETHERLANDS, FILED 2-17-2010.

**PANASSIST**

THE MARK CONSISTS OF STANDARD CHARACTERS WITHOUT CLAIM TO ANY PARTICULAR FONT, STYLE, SIZE, OR COLOR.

PRIORITY CLAIMED UNDER SEC. 44(D) ON ERPNCMNTY TM OFC APPLICATION NO. 008853384, FILED 2-2-2010, REG. NO. 008853384, DATED 9-14-2010, EXPIRES 2-2-2020.

**CLASS 9—ELECTRICAL AND SCIENTIFIC APPARATUS**

FOR COMPUTER HARDWARE; COMPUTER SOFTWARE AND HARDWARE FOR USE IN CONNECTION WITH MONITORING AND DETECTING AND DIAGNOSING PROBLEMS WITH AND ADVISING ON THE USE OF X-RAY APPARATUS, X-RAY DIFFRACTOMETERS AND SPECTROMETERS, WAFER ANALYZERS AND X-RAY TUBES; DOWNLOADABLE ELECTRONIC PUBLICATIONS, NAMELY, NEWSLETTERS, MAGAZINES, BOOKS, AND REPORTS IN THE FIELD OF X-RAY TECHNOLOGY, X-RAY APPARATUS, X-RAY DIFFRACTOMETERS AND SPECTROMETERS, AND WAFER ANALYZERS; THE PROVISION OF DATA ONLINE, NAMELY, PROVIDING A DOWNLOADABLE COMPUTER DATABASE IN THE FIELD OF X-RAY TECHNOLOGY, X-RAY APPARATUS, X-RAY DIFFRACTOMETERS AND SPECTROMETERS, AND WAFER ANALYZERS (U.S. CLS. 21, 23, 26, 36 AND 38).

**CLASS 37—CONSTRUCTION AND REPAIR**

FOR PROVIDING ONLINE ADVICE AND CONSULTANCY IN RELATION TO THE INSTALLATION, MAINTENANCE AND REPAIR OF X-RAY APPARATUS, X-RAY DIFFRACTOMETERS AND SPECTROMETERS, WAFER ANALYSERS AND X-RAY TUBES; INSTALLATION OF SCIENTIFIC AND MEASURING APPARATUS AND INSTRUMENTS, NAMELY, X-RAY DIFFRACTION AND SPECTROMETRY APPARATUS, X-RAY ANALYSERS, SPECTROMETERS AND X-RAY FLUORESCENCE SPECTROMETERS; PROVIDING ONLINE ADVICE AND CONSULTANCY SERVICES IN RELATION TO THE REPAIR AND MAINTENANCE OF COMPUTER HARDWARE RELATING TO X-RAY APPARATUS, X-RAY DIFFRACTOMETERS AND SPECTROMETERS, WAFER ANALYSERS AND X-RAY TUBES; REPAIR AND MAINTENANCE OF COMPUTER HARDWARE RELATING TO X-RAY APPARATUS, X-RAY DIFFRACTOMETERS AND SPECTROMETERS, WAFER ANALYSERS AND X-RAY TUBES; THE PROVISION OF DATA ONLINE, NAMELY, PROVIDING A COMPUTER DATABASE IN THE FIELD OF REPAIR AND MAINTENANCE OF COMPUTER HARDWARE RELATING X-RAY TECHNOLOGY, X-RAY APPARATUS, X-RAY DIFFRACTOMETERS AND SPECTROMETERS, AND WAFER ANALYZERS; INFORMATION, ADVISORY AND CONSULTANCY SERVICES ALL RELATING TO THE AFORESAID, INCLUDING ONLINE AND BY TELEPHONE (U.S. CLS. 100, 103 AND 106).

**CLASS 42—SCIENTIFIC AND COMPUTER SERVICES**

FOR PROVIDING ONLINE ADVICE AND CONSULTANCY SERVICES RELATING TO THE REPAIR AND MAINTENANCE OF COMPUTER SOFTWARE RELATING TO X-RAY APPARATUS, X-RAY DIFFRACTOMETERS AND SPECTROMETERS, WAFER ANALYSERS AND X-RAY TUBES; REPAIR AND MAINTENANCE OF COMPUTER SOFTWARE RELATING TO X-RAY APPARATUS, X-RAY DIFFRACTOMETERS AND SPECTROMETERS, WAFER ANALYSERS AND X-RAY TUBES; THE PROVISION OF DATA ONLINE, NAMELY, PROVIDING A COMPUTER DATABASE IN THE FIELD OF REPAIR AND MAINTENANCE OF COMPUTER SOFTWARE RELATING X-RAY TECHNOLOGY, X-RAY APPARATUS, X-RAY DIFFRACTOMETERS AND SPECTROMETERS, AND WAFER ANALYZERS; THE PROVISION OF DATA ONLINE, NAMELY, PROVIDING A COMPUTER DATABASE IN THE FIELD OF MATERIAL TESTING RELATING TO X-RAY TECHNOLOGY, X-RAY APPARATUS, X-RAY DIFFRACTOMETERS AND SPECTROMETERS, AND WAFER ANALYZERS; COMPUTER CONSULTANCY AND ADVISORY SERVICES IN RELATION TO COMPUTER SOFTWARE AND HARDWARE INCLUDING ONLINE AND BY TELEPHONE; INFORMATION, ADVISORY AND CONSULTANCY SERVICES ALL RELATING TO THE AFORESAID (U.S. CLS. 100 AND 101).

TRACY FLETCHER, EXAMINING ATTORNEY

SN 77-939,497. SENSEMAN PHILLIP E., TEMPE, AZ. FILED 2-19-2010.



THE COLOR(S) BLUE, RED AND BLACK IS/ARE CLAIMED AS A FEATURE OF THE MARK.

THE MARK CONSISTS OF THE WORD "SKADDLE" WITH THE LETTER "S" APPEARING AS A GEOMETRIC FIGURE OF A PERSON STANDING ON A SKATEBOARD AND HOLDING A SHAFT WHICH EXTENDS DOWNWARD FROM TWO BALLS ON THE SHAFT THAT REPRESENT ITS HANDS TO THE AREA BENEATH THE SKATEBOARD

DECK; THE WORD "SKADDLE", THE HEAD OF THE GEOMETRIC FIGURE, THE BALLS ON THE SHAFT; THE SHAFT IS RED; THE SKATEBOARD DECK, AND THE OUTLINE ON WHEELS ARE IN BLACK; EACH WHEEL HAS A BLUE DOT IN ITS CENTER REPRESENTING THE AXLE; THE STATEMENT WITHIN QUOTATION MARKS "IT'S A SKATEBOARD PADDLE!" IS BENEATH THE SKATEBOARD; THE QUOTATION MARK, THE ELLIPSIS, THE WORDING "IT'S A SKATEBOARD PADDLE" AND THE EXCLAMATION POINT ALL APPEAR IN THE COLOR BLACK.

**CLASS 25—CLOTHING**

FOR ATHLETIC FOOTWEAR; ATHLETIC SHOES; ATHLETIC UNIFORMS; BANDANAS; BASEBALL CAPS AND HATS; BEACH FOOTWEAR; BEANIES; BICYCLING GLOVES; CANVAS SHOES; CAP VISORS; CAPS; CLOTHING FOR ATHLETIC USE, NAMELY, PADDED SHORTS; COATS OF DENIM; GYM SUITS; HEAD SWEATBANDS; HOODED SWEAT SHIRTS; LONG SLEEVE PULLOVERS; PADDED JACKETS; POLO SHIRTS; SANDALS; SKIRTS; T-SHIRTS; TANK TOPS; WRISTBANDS (U.S. CLS. 22 AND 39).

**CLASS 28—TOYS AND SPORTING GOODS**

FOR BALL BEARINGS FOR SKATEBOARDS; BENDABLE TOYS; ELBOW GUARDS FOR ATHLETIC USE; ELBOW PADS FOR ATHLETIC USE; EXERCISE TREADMILLS; FINGERBOARD WHEELS; FINGERBOARDS; KNEE GUARDS FOR ATHLETIC USE; KNEE PADS FOR ATHLETIC USE; LONGBOARDS; PROTECTIVE PADDING FOR SKATEBOARDING; RUBBER ACTION BALLS; RUBBER BALLS; SKATEBOARD DECKS; SKATEBOARDS; SPORTS EQUIPMENT, NAMELY, NORDIC WALKING POLES; STAND-UP SURF PADDLES; STORAGE APPARATUS COMPRISING HOOKS, SUPPORT ARMS, AND SHELVING SPECIALLY ADAPTED FOR SPORTS EQUIPMENT; STORAGE RACKS FOR ATHLETIC EQUIPMENT; STRESS RELIEF BALLS FOR HAND EXERCISE; SURF PADDLES; TREKKING POLES; TRUCKS FOR LONGBOARDS (U.S. CLS. 22, 23, 38 AND 50).

GINA HAYES, EXAMINING ATTORNEY

SN 77-941,219. LOWERY COMPANIES, LLC, MCKINNEY, TX. FILED 2-22-2010.

# WholeLife

THE MARK CONSISTS OF STANDARD CHARACTERS WITHOUT CLAIM TO ANY PARTICULAR FONT, STYLE, SIZE, OR COLOR.

**CLASS 36—INSURANCE AND FINANCIAL**

FOR REAL ESTATE MANAGEMENT SERVICES; REAL ESTATE BROKERAGE; LEASING OF REAL ESTATE (U.S. CLS. 100, 101 AND 102).

**CLASS 37—CONSTRUCTION AND REPAIR**

FOR REAL ESTATE DEVELOPMENT; REAL ESTATE DEVELOPMENT, NAMELY, PLANNING, LAYING OUT, CONSTRUCTION AND PROJECT MANAGEMENT OF PLANNED SENIOR LIVING COMMUNITIES AND ASSOCIATED COMMERCIAL PROPERTIES (U.S. CLS. 100, 103 AND 106).

ALYSSA STEEL, EXAMINING ATTORNEY

SN 77-941,386. HIGH SCOPE EDUCATIONAL RESEARCH FOUNDATION, YPSILANTI, MI. FILED 2-22-2010.



OWNER OF U.S. REG. NOS. 1,462,318 AND 2,274,331.  
THE MARK CONSISTS OF FOUR SQUARES CONTAINING AN OUTLINE OF AN INDIVIDUAL IN EACH SQUARE NEXT, TO THE LEFT OF THE WORD "HIGHSCOPE".

#### **CLASS 9—ELECTRICAL AND SCIENTIFIC APPARATUS**

FOR AUDIOVISUAL EDUCATIONAL MATERIALS, NAMELY, CDS, DVDS, AND VIDEOS IN THE FIELDS OF HUMAN DEVELOPMENT, CURRICULUM DEVELOPMENT AND IMPLEMENTATION, PROFESSIONAL DEVELOPMENT, ASSESSMENT, RESEARCH AND EVALUATION, AND POLICY (U.S. CLS. 21, 23, 26, 36 AND 38).

#### **CLASS 16—PAPER GOODS AND PRINTED MATTER**

FOR PRINT EDUCATIONAL MATERIALS, NAMELY, BOOKS, PERIODICALS, GUIDES, ACTIVITY CARDS, MANUALS, POSTERS, FACT SHEETS, NEWSLETTERS, AND ASSESSMENT TOOLS, IN THE FIELDS OF HUMAN DEVELOPMENT, CURRICULUM DEVELOPMENT AND IMPLEMENTATION, PROFESSIONAL DEVELOPMENT, ASSESSMENT, RESEARCH AND EVALUATION, AND POLICY; PRINTED TRAINING MATERIALS IN THE FIELDS OF EARLY CHILDHOOD, ELEMENTARY AND SECONDARY EDUCATION; PRINTED EDUCATION ASSESSMENT MATERIALS IN THE FIELDS OF EARLY CHILDHOOD, ELEMENTARY AND SECONDARY EDUCATION; PRINTED CURRICULUM ASSESSMENTS IN THE FIELDS OF EARLY CHILDHOOD, ELEMENTARY, AND SECONDARY EDUCATION; PLANNING AND EVALUATION QUESTIONNAIRES AND SCORING SYSTEMS, NAMELY, PRINTED FORMS FOR MEASURING SCHOOL READINESS, PREPAREDNESS, PERFORMANCE, QUALITY AND EFFECTIVENESS; EDUCATIONAL KITS SOLD AS A UNIT IN THE FIELDS OF EARLY CHILDHOOD, ELEMENTARY AND SECONDARY EDUCATION CONSISTING PRIMARILY OF AN EDUCATIONAL BOOK AND DVD; EDUCATIONAL KITS SOLD AS A UNIT IN THE FIELDS OF EARLY CHILDHOOD, ELEMENTARY AND SECONDARY EDUCATION CONSISTING PRIMARILY OF AN EDUCATIONAL BOOK AND CD (U.S. CLS. 2, 5, 22, 23, 29, 37, 38 AND 50).

#### **CLASS 41—EDUCATION AND ENTERTAINMENT**

FOR PROFESSIONAL DEVELOPMENT SERVICES, NAMELY, CONDUCTING COURSES, WORKSHOPS, AND SEMINARS IN THE FIELDS OF HUMAN DEVELOPMENT, CURRICULUM DEVELOPMENT AND IMPLEMENTATION, PROFESSIONAL DEVELOPMENT, ASSESSMENT, RESEARCH AND EVALUATION, AND POLICY; EDUCATIONAL SERVICES, NAMELY, CONDUCTING COURSES, WORKSHOPS, AND SEMINARS IN THE FIELDS OF EARLY CHILDHOOD, ELEMENTARY AND SECONDARY EDUCATION; EDUCATIONAL SERVICES, NAMELY, EVALUATION, CONSULTATION, ASSESSMENT, AND TRAINING SERVICES IN THE FIELD OF EDUCATION; EDUCATIONAL SERVICES, NAMELY, EVALUATION, CONSULTATION, ASSESSMENT, AND TRAINING SERVICES RELATING TO MEASURING SCHOOL PREPAREDNESS AND EFFECTIVENESS; EDUCATIONAL SERVICES, NAMELY, EVALUATION, CONSULTATION, ASSESSMENT, AND TRAINING SERVICES RELATING TO CURRICULUM DEVELOPMENT; EDUCATIONAL SERVICES, NAMELY, EVALUATION, CONSULTATION, AND ASSESSMENT OF STAFF PRACTICES, RESOURCES, AND PROGRAM IMPROVEMENT IN THE FIELDS OF EARLY CHILDHOOD, ELEMENTARY AND SECONDARY EDUCATION; EDUCATIONAL SERVICES, NAMELY, EVALUATION, CONSULTATION, ASSESSMENT, AND DEVELOPMENT OF PROGRAM IMPROVEMENT STRATEGIES IN THE FIELDS OF EARLY CHILDHOOD, ELEMENTARY AND SECONDARY EDUCATION FOR ACCOUNTABILITY PURPOSES; EDUCATIONAL SERVICES, NAMELY, DEVELOPMENT OF COMPREHENSIVE CURRICULUM AND ASSESSMENT SERVICES FOR OTHERS (U.S. CLS. 100, 101 AND 107).

ELIZABETH KAJUBI, EXAMINING ATTORNEY

SN 77-941,395. HIGH SCOPE EDUCATIONAL RESEARCH FOUNDATION, YPSILANTI, MI. FILED 2-22-2010.



THE MARK CONSISTS OF STANDARD CHARACTERS WITHOUT CLAIM TO ANY PARTICULAR FONT, STYLE, SIZE, OR COLOR.

OWNER OF U.S. REG. NOS. 1,462,318 AND 2,274,331.

#### **CLASS 9—ELECTRICAL AND SCIENTIFIC APPARATUS**

FOR AUDIOVISUAL EDUCATIONAL MATERIALS, NAMELY, CDS, DVDS, AND VIDEOS IN THE FIELDS OF HUMAN DEVELOPMENT, CURRICULUM DEVELOPMENT AND IMPLEMENTATION, PROFESSIONAL DEVELOPMENT, ASSESSMENT, RESEARCH AND EVALUATION, AND POLICY (U.S. CLS. 21, 23, 26, 36 AND 38).

**CLASS 16—PAPER GOODS AND PRINTED MATTER**

FOR PRINT EDUCATIONAL MATERIALS, NAMELY, BOOKS, PERIODICALS, GUIDES, ACTIVITY CARDS, MANUALS, POSTERS, FACT SHEETS, NEWSLETTERS, AND ASSESSMENT TOOLS, IN THE FIELDS OF HUMAN DEVELOPMENT, CURRICULUM DEVELOPMENT AND IMPLEMENTATION, PROFESSIONAL DEVELOPMENT, ASSESSMENT, RESEARCH AND EVALUATION, AND POLICY; PRINTED TRAINING MATERIALS IN THE FIELDS OF EARLY CHILDHOOD, ELEMENTARY AND SECONDARY EDUCATION; PRINTED EDUCATION ASSESSMENT MATERIALS IN THE FIELDS OF EARLY CHILDHOOD, ELEMENTARY AND SECONDARY EDUCATION; PRINTED CURRICULUM ASSESSMENTS IN THE FIELDS OF EARLY CHILDHOOD, ELEMENTARY, AND SECONDARY EDUCATION; PLANNING AND EVALUATION QUESTIONNAIRES AND SCORING SYSTEMS, NAMELY, PRINTED FORMS FOR MEASURING SCHOOL READINESS, PREPAREDNESS, PERFORMANCE, QUALITY AND EFFECTIVENESS; EDUCATIONAL KITS SOLD AS A UNIT IN THE FIELDS OF EARLY CHILDHOOD, ELEMENTARY AND SECONDARY EDUCATION CONSISTING PRIMARILY OF AN EDUCATIONAL BOOK AND DVD; EDUCATIONAL KITS SOLD AS A UNIT IN THE FIELDS OF EARLY CHILDHOOD, ELEMENTARY AND SECONDARY EDUCATION CONSISTING PRIMARILY OF AN EDUCATIONAL BOOK AND CD (U.S. CLS. 2, 5, 22, 23, 29, 37, 38 AND 50).

SN 77-942,000. EASTERN GLOBAL TRIUMPH SDN BHD, KUALA LUMPUR, MALAYSIA, FILED 2-22-2010.

# MIDO

THE MARK CONSISTS OF STANDARD CHARACTERS WITHOUT CLAIM TO ANY PARTICULAR FONT, STYLE, SIZE, OR COLOR.

**CLASS 29—MEATS AND PROCESSED FOODS**

FOR COOKING OIL; JELLIES AND JAMS; MILK POWDER; PRESERVED, DRIED AND COOKED FRUIT AND VEGETABLES (U.S. CL. 46).

**CLASS 30—STAPLE FOODS**

FOR COFFEE; KETCHUP; OATMEAL (U.S. CL. 46). TRACY WHITTAKER-BROWN, EXAMINING ATTORNEY

**CLASS 41—EDUCATION AND ENTERTAINMENT**

FOR PROFESSIONAL DEVELOPMENT SERVICES, NAMELY, CONDUCTING COURSES, WORKSHOPS, AND SEMINARS IN THE FIELDS OF HUMAN DEVELOPMENT, CURRICULUM DEVELOPMENT AND IMPLEMENTATION, PROFESSIONAL DEVELOPMENT, ASSESSMENT, RESEARCH AND EVALUATION, AND POLICY; EDUCATIONAL SERVICES, NAMELY, CONDUCTING COURSES, WORKSHOPS, AND SEMINARS IN THE FIELDS OF EARLY CHILDHOOD, ELEMENTARY AND SECONDARY EDUCATION; EDUCATIONAL SERVICES, NAMELY, EVALUATION, CONSULTATION, ASSESSMENT, AND TRAINING SERVICES IN THE FIELD OF EDUCATION; EDUCATIONAL SERVICES, NAMELY, EVALUATION, CONSULTATION, ASSESSMENT, AND TRAINING SERVICES RELATING TO MEASURING SCHOOL PREPAREDNESS AND EFFECTIVENESS; EDUCATIONAL SERVICES, NAMELY, EVALUATION, CONSULTATION, ASSESSMENT, AND TRAINING SERVICES RELATING TO CURRICULUM DEVELOPMENT; EDUCATIONAL SERVICES, NAMELY, EVALUATION, CONSULTATION, AND ASSESSMENT OF STAFF PRACTICES, RESOURCES, AND PROGRAM IMPROVEMENT IN THE FIELDS OF EARLY CHILDHOOD, ELEMENTARY AND SECONDARY EDUCATION; EDUCATIONAL SERVICES, NAMELY, EVALUATION, CONSULTATION, ASSESSMENT, AND DEVELOPMENT OF PROGRAM IMPROVEMENT STRATEGIES IN THE FIELDS OF EARLY CHILDHOOD, ELEMENTARY AND SECONDARY EDUCATION FOR ACCOUNTABILITY PURPOSES; EDUCATIONAL SERVICES, NAMELY, DEVELOPMENT OF COMPREHENSIVE CURRICULUM AND ASSESSMENT SERVICES FOR OTHERS (U.S. CLS. 100, 101 AND 107).

ELIZABETH KAJUBI, EXAMINING ATTORNEY

SN 77-947,458. VENDOR SAFE TECHNOLOGIES, LLC, HOUSTON, TX. FILED 3-1-2010.

# vendorsafe

THE MARK CONSISTS OF STANDARD CHARACTERS WITHOUT CLAIM TO ANY PARTICULAR FONT, STYLE, SIZE, OR COLOR.

OWNER OF U.S. REG. NO. 3,106,071.

**CLASS 36—INSURANCE AND FINANCIAL**

FOR PROVIDING ELECTRONIC PROCESSING OF CREDIT CARD TRANSACTIONS AND ELECTRONIC PAYMENTS VIA A GLOBAL COMPUTER NETWORK (U.S. CLS. 100, 101 AND 102).

FIRST USE 12-1-2004; IN COMMERCE 12-1-2004.

**CLASS 38—COMMUNICATION**

FOR PROVIDING ELECTRONIC TRANSMISSION OF CREDIT CARD TRANSACTION DATA AND ELECTRONIC PAYMENT DATA VIA A GLOBAL COMPUTER NETWORK (U.S. CLS. 100, 101 AND 104).

FIRST USE 12-1-2004; IN COMMERCE 12-1-2004.

**CLASS 42—SCIENTIFIC AND COMPUTER SERVICES**

FOR COMPUTER NETWORK DESIGN AND COMPUTER SOFTWARE DESIGN FOR THE PURPOSE OF NETWORK SECURITY, REMOTE COMMUNICATION AND MONITORING, ESPECIALLY AS IT RELATES TO CREDIT CARD OR PAYMENT CARD ENVIRONMENTS THAT NEED TO MEET THE PAYMENT CARD INDUSTRY DATA SECURITY STANDARD; DESIGN FOR OTHERS IN THE FIELD OF COMPUTER NETWORKS, SOFTWARE, AND ENGINEERING FOR THE PURPOSE OF NETWORK SECURITY, REMOTE COMMUNICATION AND MONITORING, ESPECIALLY AS IT RELATES TO CREDIT CARD OR PAYMENT CARD ENVIRONMENTS THAT NEED TO MEET THE PAYMENT CARD INDUSTRY DATA SECURITY STANDARD; DESIGN OF COMPUTER NETWORKS AND SOFTWARE FOR OTHERS FOR THE PURPOSE OF NETWORK SECURITY, REMOTE COMMUNICATION AND MONITORING, ESPECIALLY AS IT RELATES TO CREDIT CARD OR PAYMENT CARD ENVIRONMENTS THAT NEED TO MEET THE PAYMENT CARD INDUSTRY DATA SECURITY STANDARD; ON-LINE SECURITY SERVICES, NAMELY, PROVIDING SECURITY AND ANONYMITY FOR ELECTRONICALLY TRANSMITTED CREDIT CARD TRANSACTIONS (U.S. CLS. 100 AND 101).

FIRST USE 12-1-2004; IN COMMERCE 12-1-2004.  
PATRICIA EVANKO, EXAMINING ATTORNEY

SN 77-947,619. J.D. MURCHISON INTERESTS, INC., PLANO, TX. FILED 3-1-2010.

J.D. MURCHISON INTERESTS,  
INC.

THE MARK CONSISTS OF STANDARD CHARACTERS WITHOUT CLAIM TO ANY PARTICULAR FONT, STYLE, SIZE, OR COLOR.

NO CLAIM IS MADE TO THE EXCLUSIVE RIGHT TO USE "INC.", APART FROM THE MARK AS SHOWN.

THE NAME(S), PORTRAIT(S), AND/OR SIGNATURE(S) SHOWN IN THE MARK IDENTIFIES "J. D. MURCHISON", WHOSE CONSENT(S) TO REGISTER IS MADE OF RECORD.

**CLASS 37—CONSTRUCTION AND REPAIR**

FOR OIL AND GAS WELL DRILLING (U.S. CLS. 100, 103 AND 106).

FIRST USE 0-0-1982; IN COMMERCE 0-0-1982.

**CLASS 40—MATERIAL TREATMENT**

FOR OIL AND GAS PRODUCTION (U.S. CLS. 100, 103 AND 106).

FIRST USE 0-0-1982; IN COMMERCE 0-0-1982.

**CLASS 42—SCIENTIFIC AND COMPUTER SERVICES**

FOR OIL AND GAS EXPLORATION (U.S. CLS. 100 AND 101).

FIRST USE 0-0-1982; IN COMMERCE 0-0-1982.  
GILBERT SWIFT, EXAMINING ATTORNEY

SN 77-947,684. VENDOR SAFE TECHNOLOGIES, LLC, HOUSTON, TX. FILED 3-1-2010.



OWNER OF U.S. REG. NO. 3,106,071.

NO CLAIM IS MADE TO THE EXCLUSIVE RIGHT TO USE "TECHNOLOGIES" AND "PROTECT DATA. SECURE BUSINESS", APART FROM THE MARK AS SHOWN.

THE COLOR(S) GOLD, DARK BLUE, AND MEDIUM BLUE IS/ARE CLAIMED AS A FEATURE OF THE MARK.

THE MARK CONSISTS OF THE WORD "VENDOR" IN DARK BLUE FOLLOWED BY THE WORD "SAFE" WITH NO SPACE SEPARATING THE TWO WORDS, IN WHICH THE "S", THE "F", AND THE "E" ARE IN MEDIUM BLUE, AND IN WHICH THE "A" IS REPRESENTED BY THE SYMBOL OF A LOCK WHICH IS IN DARK BLUE AND OVER WHICH THREE PROGRESSIVELY LARGER CONCENTRIC ARCS APPEAR, AND UNDER WHICH THE PREVIOUSLY DESCRIBED ART APPEARS A RECTANGULAR-SHAPED GOLD BAR APPROXIMATELY ONE-THIRD THE HEIGHT OF THE "V" WHICH BEGINS THE WORD "VENDOR" AND INSIDE WHICH IS THE WORD "TECHNOLOGIES" IN DARK BLUE IN ALL CAPITAL LETTERS, RIGHT JUSTIFIED, UNDERNEATH WHICH, WITH FULL JUSTIFICATION IN RELATION TO THE GOLD BAR, ARE THE WORDS "PROJECT DATA. SECURE BUSINESS." IN MEDIUM BLUE.

**CLASS 36—INSURANCE AND FINANCIAL**

FOR PROVIDING ELECTRONIC PROCESSING OF CREDIT CARD TRANSACTIONS AND ELECTRONIC PAYMENTS VIA A GLOBAL COMPUTER NETWORK (U.S. CLS. 100, 101 AND 102).

FIRST USE 8-1-2009; IN COMMERCE 8-1-2009.

**CLASS 38—COMMUNICATION**

FOR PROVIDING ELECTRONIC TRANSMISSION OF CREDIT CARD TRANSACTION DATA AND ELECTRONIC PAYMENT DATA VIA A GLOBAL COMPUTER NETWORK (U.S. CLS. 100, 101 AND 104).

FIRST USE 8-1-2009; IN COMMERCE 8-1-2009.

**CLASS 42—SCIENTIFIC AND COMPUTER SERVICES**

FOR COMPUTER NETWORK DESIGN AND COMPUTER SOFTWARE DESIGN FOR THE PURPOSE OF NETWORK SECURITY, REMOTE COMMUNICATION AND MONITORING, ESPECIALLY AS IT RELATES TO CREDIT CARD OR PAYMENT CARD ENVIRONMENTS THAT NEED TO MEET THE PAYMENT CARD INDUSTRY DATA SECURITY STANDARD; DESIGN FOR OTHERS IN THE FIELD OF COMPUTER NETWORKS, SOFTWARE, AND ENGINEERING FOR THE PURPOSE OF NETWORK SECURITY, REMOTE COMMUNICATION AND MONITORING, ESPECIALLY AS IT RELATES TO CREDIT CARD OR PAYMENT CARD ENVIRONMENTS THAT NEED TO MEET THE PAYMENT CARD INDUSTRY DATA SECURITY STANDARD; DESIGN OF COMPUTER NETWORKS AND SOFTWARE FOR OTHERS FOR THE PURPOSE OF NETWORK SECURITY, REMOTE COMMUNICATION AND MONITORING, ESPECIALLY AS IT RELATES TO CREDIT CARD OR PAYMENT CARD ENVIRONMENTS THAT NEED TO MEET THE PAYMENT CARD INDUSTRY DATA SECURITY STANDARD; ON-LINE SECURITY SERVICES, NAMELY, PROVIDING SECURITY AND ANONYMITY FOR ELECTRONICALLY TRANSMITTED CREDIT CARD TRANSACTIONS (U.S. CLS. 100 AND 101).

FIRST USE 8-1-2009; IN COMMERCE 8-1-2009.  
PATRICIA EVANKO, EXAMINING ATTORNEY



SN 77-955,538. HDS COSMETICS LAB, INC., NEW YORK, NY. FILED 3-10-2010.



OWNER OF U.S. REG. NOS. 1,957,741 AND 3,175,843.  
NO CLAIM IS MADE TO THE EXCLUSIVE RIGHT TO USE "DOCTOR'S DERMATOLOGIC FORMULA", APART FROM THE MARK AS SHOWN.  
THE MARK CONSISTS OF THE LETTERS "DDF" ABOVE THE WORDS "DOCTOR'S DERMATOLOGIC FORMULA".

**CLASS 3—COSMETICS AND CLEANING PREPARATIONS**

FOR NON-MEDICATED SKIN CARE PREPARATIONS (U.S. CLS. 1, 4, 6, 50, 51 AND 52).

**CLASS 5—PHARMACEUTICALS**

FOR MEDICATED SKIN CARE PREPARATIONS (U.S. CLS. 6, 18, 44, 46, 51 AND 52).  
CYNTHIA TRIPI, EXAMINING ATTORNEY

SN 77-955,634. PANOPTO, INC., PITTSBURGH, PA. FILED 3-10-2010.

**PANOPTO**

THE MARK CONSISTS OF STANDARD CHARACTERS WITHOUT CLAIM TO ANY PARTICULAR FONT, STYLE, SIZE, OR COLOR.

**CLASS 9—ELECTRICAL AND SCIENTIFIC APPARATUS**

FOR DOWNLOADABLE COMPUTER SOFTWARE FOR THE CAPTURE, RECORDING, AND DISTRIBUTION OF MULTIMEDIA CONTENT VIA A COMPUTER NETWORK TO PERSONAL COMPUTERS, PDAS AND CELL PHONES (U.S. CLS. 21, 23, 26, 36 AND 38).  
FIRST USE 5-0-2007; IN COMMERCE 5-0-2007.

**CLASS 41—EDUCATION AND ENTERTAINMENT**

FOR PROVIDING COMPUTER SOFTWARE TRAINING TO END USERS OF SOFTWARE (U.S. CLS. 100, 101 AND 107).  
FIRST USE 10-0-2007; IN COMMERCE 10-0-2007.

**CLASS 42—SCIENTIFIC AND COMPUTER SERVICES**

FOR PROVIDING INSTALLATION OF SOFTWARE AND TECHNICAL SUPPORT SERVICES, NAMELY, TECHNICAL ADVICE RELATED TO THE INSTALLATION OF SOFTWARE TO END USERS; AND COMPUTER SERVICES, NAMELY, INTERACTIVE HOSTING SERVICES WHICH ALLOW THE USER TO RECORD AND DISPLAY AUDIO AND VIDEO CONTENT (U.S. CLS. 100 AND 101).

FIRST USE 10-0-2007; IN COMMERCE 10-0-2007.  
MARY ROSSMAN, EXAMINING ATTORNEY

SN 77-955,643. PANOPTO, INC., PITTSBURGH, PA. FILED 3-10-2010.

**PANOPTO**

THE COLOR(S) GREEN, GRAY, AND BLACK IS/ARE CLAIMED AS A FEATURE OF THE MARK.

THE MARK CONSISTS OF THE LITERAL ELEMENT "PANOPTO," WITH THE LETTERS "PAN" IN BLACK, THE INNER LETTER "O" BEING FORMED BY A GRAY TRIANGLE INSIDE A GREEN CIRCLE, AND THE LETTERS "PTO" IN BLACK.

**CLASS 9—ELECTRICAL AND SCIENTIFIC APPARATUS**

FOR DOWNLOADABLE COMPUTER SOFTWARE FOR THE CAPTURE, RECORDING, AND DISTRIBUTION OF MULTIMEDIA CONTENT VIA A COMPUTER NETWORK TO PERSONAL COMPUTERS, PDAS AND CELL PHONES (U.S. CLS. 21, 23, 26, 36 AND 38).  
FIRST USE 2-0-2008; IN COMMERCE 2-0-2008.

**CLASS 41—EDUCATION AND ENTERTAINMENT**

FOR PROVIDING COMPUTER SOFTWARE TRAINING TO END USERS OF SOFTWARE (U.S. CLS. 100, 101 AND 107).  
FIRST USE 2-0-2008; IN COMMERCE 2-0-2008.

**CLASS 42—SCIENTIFIC AND COMPUTER SERVICES**

FOR PROVIDING INSTALLATION OF SOFTWARE AND TECHNICAL SUPPORT SERVICES, NAMELY, TECHNICAL ADVICE RELATED TO THE INSTALLATION OF SOFTWARE TO END USERS; AND COMPUTER SERVICES, NAMELY, INTERACTIVE HOSTING SERVICES WHICH ALLOW THE USER TO RECORD AND DISPLAY AUDIO AND VIDEO CONTENT (U.S. CLS. 100 AND 101).

FIRST USE 2-0-2008; IN COMMERCE 2-0-2008.  
MARY ROSSMAN, EXAMINING ATTORNEY

SN 77-956,534. PICKEL, MICHAEL, R, WEST GROVE, PA. FILED 3-11-2010.

**LawnScapes**

THE COLOR(S) BROWN, GREEN IS/ARE CLAIMED AS A FEATURE OF THE MARK.

THE MARK CONSISTS OF THE STYLIZED WORDING "LAWNSCAPES" IN DARK GREEN, WITH A LEAF IN LIGHT GREEN WITH A BROWN STEM BENEATH THE WORDING.

#### **CLASS 5—PHARMACEUTICALS**

FOR HERBICIDES, INSECTICIDES, PESTICIDES AND FUNGICIDES FOR HOME, GARDEN AND LAWN USE AND FOR PROFESSIONAL USE (U.S. CLS. 6, 18, 44, 46, 51 AND 52).

#### **CLASS 44—MEDICAL, BEAUTY AND AGRICULTURAL SERVICES**

FOR LANDSCAPE DESIGN; LAWN CARE; LAWN MOWING SERVICES (U.S. CLS. 100 AND 101).  
KELLEY WELLS, EXAMINING ATTORNEY

#### **CLASS 42—SCIENTIFIC AND COMPUTER SERVICES**

FOR PROVIDING AN INTERACTIVE WEB SITE THAT ENABLES USERS TO ENTER, ACCESS, TRACK, SEARCH, MONITOR, PURCHASE AND GENERATE REPORTS REGARDING MEDICAL EQUIPMENT, FURNITURE AND FIXTURES; PROVIDING TEMPORARY USE OF NON-DOWNLOADABLE COMPUTER SOFTWARE FOR ENTERING, ACCESSING, TRACKING, MONITORING, COST ESTIMATING, PLANNING, PURCHASING AND GENERATING REPORTS REGARDING MEDICAL EQUIPMENT, FURNITURE AND FIXTURES; PLANNING AND LAYOUT DESIGN FOR THE INTERIOR SPACE OF HEALTHCARE AND MEDICAL FACILITIES; INTERIOR DESIGN SERVICES INCLUDING SPACE PLANNING, EQUIPMENT SELECTION, FURNITURE SELECTION, AND FIXTURE SELECTION; PLANNING OF BUILDINGS AND INFRASTRUCTURE SYSTEMS FOR BUILDINGS; CONSULTING IN THE FIELD OF INTERIOR DESIGN FOR HEALTHCARE AND MEDICAL FACILITIES (U.S. CLS. 100 AND 101).

FIRST USE 11-30-2008; IN COMMERCE 11-30-2008.  
ROBERT STRUCK, EXAMINING ATTORNEY

SN 77-956,909. ESP DEVELOPMENT, LLC, SMYRNA, GA.  
FILED 3-11-2010.

**ESP**

THE MARK CONSISTS OF STANDARD CHARACTERS WITHOUT CLAIM TO ANY PARTICULAR FONT, STYLE, SIZE, OR COLOR.

#### **CLASS 9—ELECTRICAL AND SCIENTIFIC APPARATUS**

FOR COMPUTER SOFTWARE FOR USE IN CREATING AND MANAGING BUDGETS IN THE FIELD OF HEALTHCARE FACILITY DESIGN AND PLANNING, INCLUDING MEDICAL EQUIPMENT; COMPUTER SOFTWARE FOR USE IN GATHERING AND MANAGING INFORMATION IN THE FIELD OF HEALTHCARE FACILITY DESIGN AND PLANNING, INCLUDING MEDICAL EQUIPMENT; DATABASE MANAGEMENT SOFTWARE FOR USE IN THE FIELD OF HEALTHCARE FACILITY DESIGN AND PLANNING, INCLUDING MEDICAL EQUIPMENT; SOFTWARE USED IN THE BUDGETING AND PLANNING OF EQUIPMENT REQUIREMENTS FOR FACILITIES; ARCHITECTURAL DESIGN SOFTWARE; COMPUTER SOFTWARE FOR MANAGING REQUESTS AND RESPONSES BETWEEN BUYERS AND SELLERS IN THE FIELD OF HEALTHCARE FACILITY DESIGN AND PLANNING, INCLUDING MEDICAL EQUIPMENT; COMPUTER SOFTWARE FOR FORECASTING DEMAND IN THE FIELD OF HEALTHCARE FACILITY DESIGN AND PLANNING, INCLUDING MEDICAL EQUIPMENT (U.S. CLS. 21, 23, 26, 36 AND 38).  
FIRST USE 11-30-2008; IN COMMERCE 11-30-2008.

#### **CLASS 35—ADVERTISING AND BUSINESS**

FOR BUSINESS CONSULTING SERVICES IN THE FIELD OF HEALTHCARE FACILITY DESIGN AND PLANNING, NAMELY, COST ESTIMATING AND BUDGETING FOR MEDICAL FACILITIES, MEDICAL EQUIPMENT, MEDICAL FURNITURE AND MEDICAL FIXTURES; COST PRICE ANALYSIS IN THE FIELD OF EQUIPMENT SELECTION FOR HEALTHCARE AND MEDICAL FACILITIES (U.S. CLS. 100, 101 AND 102).  
FIRST USE 11-30-2008; IN COMMERCE 11-30-2008.

SN 77-957,010. NIMBUS GAMES INC., WALNUT CREEK, CA. FILED 3-11-2010.

#### **BOUNTY QUEST MYSTERY**

THE MARK CONSISTS OF STANDARD CHARACTERS WITHOUT CLAIM TO ANY PARTICULAR FONT, STYLE, SIZE, OR COLOR.

NO CLAIM IS MADE TO THE EXCLUSIVE RIGHT TO USE "MYSTERY", APART FROM THE MARK AS SHOWN.

#### **CLASS 9—ELECTRICAL AND SCIENTIFIC APPARATUS**

FOR DOWNLOADABLE COMPUTER GAME SOFTWARE; DOWNLOADABLE INTERACTIVE VIDEO GAME PROGRAMS; DOWNLOADABLE ELECTRONIC GAME SOFTWARE THAT MAY BE ACCESSED VIA THE INTERNET, COMPUTERS, WIRELESS DEVICES, HANDHELD ELECTRONIC DEVICES AND VIA OTHER ELECTRONIC MEANS OF DELIVERY; DOWNLOADABLE VIRTUAL GOODS, NAMELY, COMPUTER PROGRAMS FEATURING AVATARS, MASCOTS, PETS, ARTICLES OF CLOTHING, ACCESSORIES, FURNITURE, DECORATIONS, VEHICLES AND OTHER CONSUMER GOODS FOR USE IN ONLINE VIRTUAL WORLDS (U.S. CLS. 21, 23, 26, 36 AND 38).

**CLASS 41—EDUCATION AND ENTERTAINMENT**

FOR PROVIDING ONLINE GAMES; ENTERTAINMENT SERVICES, NAMELY, PROVIDING TEMPORARY USE OF COMPUTER GAMES, VIDEO GAMES; ENTERTAINMENT SERVICES, NAMELY, PROVIDING ONLINE COMPUTER GAMES AND VIDEO GAMES; ENTERTAINMENT SERVICES, NAMELY, PROVIDING REVIEWS OF COMPUTER GAMES, AND PROVIDING ENTERTAINMENT INFORMATION RELATING TO COMPUTER GAMES; ENTERTAINMENT SERVICES, NAMELY, PROVIDING VIRTUAL ENVIRONMENTS IN WHICH USERS CAN INTERACT THROUGH SOCIAL COMPUTER GAMES FOR RECREATIONAL, LEISURE, ENTERTAINMENT; ENTERTAINMENT SERVICES, NAMELY, PROVIDING NEWS AND INFORMATION REGARDING COMPUTER GAMES AND OPPORTUNITIES; ENTERTAINMENT SERVICES, NAMELY, PROVIDING SOCIAL GAMES VIA THE INTERNET, OTHER COMMUNICATION NETWORKS WITH THIRD PARTIES, OR OTHER ELECTRONIC MEANS (U.S. CLS. 100, 101 AND 107).

TRACY WHITTAKER-BROWN, EXAMINING ATTORNEY

SN 77-958,278. TURCO, CANDELA, NEW YORK, NY. FILED 3-12-2010.

# PASIONAE

THE MARK CONSISTS OF STANDARD CHARACTERS WITHOUT CLAIM TO ANY PARTICULAR FONT, STYLE, SIZE, OR COLOR.

**CLASS 18—LEATHER GOODS**

FOR CLUTCH PURSES; HANDBAGS; LEATHER BAGS AND WALLETS; PURSES; SHOULDER BAGS; WALLETS (U.S. CLS. 1, 2, 3, 22 AND 41).

FIRST USE 2-9-2009; IN COMMERCE 11-4-2009.

**CLASS 25—CLOTHING**

FOR BELTS; BLOUSES; COATS; DRESSES; GLOVES; HATS; JACKETS; LEATHER BELTS; PANTS; PULL-OVERS; SCARVES; SHAWLS; SHIRTS; SHORTS; SKIRTS; SWEATERS; T-SHIRTS; TOPS; TUNICS; VESTS (U.S. CLS. 22 AND 39).

FIRST USE 2-9-2009; IN COMMERCE 11-4-2009.

PAUL E. FAHRENKOPF, EXAMINING ATTORNEY

SN 77-957,748. HONESTLY NOW, INC., POUND RIDGE, NY. FILED 3-12-2010.

# HONESTLY, NOW

THE MARK CONSISTS OF STANDARD CHARACTERS WITHOUT CLAIM TO ANY PARTICULAR FONT, STYLE, SIZE, OR COLOR.

**CLASS 42—SCIENTIFIC AND COMPUTER SERVICES**

FOR PROVIDING TEMPORARY USE OF A WEB-BASED SOFTWARE TO ENABLE DISPLAYING AND SHARING ELECTRONIC MEDIA OR INFORMATION THAT ALLOWS USERS TO CONSULT WITH AND SOLICIT OPINIONS AND FEEDBACK FROM OTHER USERS REGARDING PERSONAL FASHION STYLE, WORK WARDROBE STYLE, PERSONAL RELATIONSHIPS, WORKPLACE RELATIONSHIPS AND OTHER PROFESSIONAL AND CAREER ISSUES, AND TABULATE THE RESULTS (U.S. CLS. 100 AND 101).

**CLASS 45—PERSONAL AND LEGAL SERVICES**

FOR PERSONAL IMAGE CONSULTING SERVICES PROVIDED ON-LINE; PROVIDING A WEBSITE FEATURING INFORMATION ABOUT PERSONAL FASHION STYLE, WORK WARDROBE STYLE, AND PERSONAL RELATIONSHIPS AND DATING (U.S. CLS. 100 AND 101).

DEBRA LEE, EXAMINING ATTORNEY

SN 77-958,285. TURCO, CANDELA, NEW YORK, NY. FILED 3-12-2010.



THE MARK CONSISTS OF A VERTICAL RECTANGLE WITH THE WORD "PASIONAE" AT THE TOP. WITHIN THE RECTANGLE ARE EIGHT TRIANGLES POINTING IN DIFFERENT DIRECTIONS ONE OF WHICH IS OVERLAPPING WITH A TRIANGLE OUTLINE.

**CLASS 18—LEATHER GOODS**

FOR CLUTCH PURSES; HANDBAGS; LEATHER BAGS AND WALLETS; PURSES; SHOULDER BAGS; WALLETS (U.S. CLS. 1, 2, 3, 22 AND 41).

FIRST USE 6-10-2009; IN COMMERCE 11-4-2009.

**CLASS 25—CLOTHING**

FOR BELTS; BLOUSES; COATS; DRESSES; GLOVES; HATS; JACKETS; LEATHER BELTS; PANTS; PULL-OVERS; SCARVES; SHAWLS; SHIRTS; SHORTS; SKIRTS; SWEATERS; T-SHIRTS; TOPS; TUNICS; VESTS (U.S. CLS. 22 AND 39).

FIRST USE 6-10-2009; IN COMMERCE 11-4-2009.

PAUL E. FAHRENKOPF, EXAMINING ATTORNEY

SN 77-960,703. CITY OF BEVERLY HILLS, BEVERLY HILLS, CA. FILED 3-17-2010.

## THE SMART CITY

THE MARK CONSISTS OF STANDARD CHARACTERS WITHOUT CLAIM TO ANY PARTICULAR FONT, STYLE, SIZE, OR COLOR.

NO CLAIM IS MADE TO THE EXCLUSIVE RIGHT TO USE "CITY", APART FROM THE MARK AS SHOWN.

### CLASS 25—CLOTHING

FOR CLOTHING, NAMELY, SHIRTS (U.S. CLS. 22 AND 39).

### CLASS 35—ADVERTISING AND BUSINESS

FOR PROMOTING BUSINESS, TOURISM, CULTURAL EVENTS AND ECONOMIC DEVELOPMENT IN THE CITY OF BEVERLY HILLS (U.S. CLS. 100, 101 AND 102).

### CLASS 41—EDUCATION AND ENTERTAINMENT

FOR EDUCATION AND ENTERTAINMENT SERVICES, NAMELY, ORGANIZING AND CONDUCTING COMMUNITY, CULTURAL, EDUCATIONAL, RECREATIONAL AND SAFETY-PREPAREDNESS EVENTS; EDUCATIONAL CLASSES IN THE FIELDS OF ART, DANCE, MUSIC, FINE ARTS, FOREIGN LANGUAGE, ATHLETICS, HOMEMAKING, COMPUTERS, LEISURE ACTIVITIES, TECHNOLOGY, ECOLOGY, ENVIRONMENTAL INITIATIVES, SUSTAINABLE AND SOCIALLY RESPONSIBLE PRACTICES, GOVERNMENT, POLITICS, AND SCIENCE; PROVIDING INFORMATION, NEWS AND COMMENTARY ABOUT COMMUNITY, CULTURAL AND CIVIC EVENTS (U.S. CLS. 100, 101 AND 107).

C. DIONNE CLYBURN, EXAMINING ATTORNEY

SN 77-963,674. SUNRISE GLOBAL SOLUTIONS, INC., BELLEVUE, WA. FILED 3-19-2010.

## MIOBY

THE MARK CONSISTS OF STANDARD CHARACTERS WITHOUT CLAIM TO ANY PARTICULAR FONT, STYLE, SIZE, OR COLOR.

THE WORDING "MIOBY" HAS NO MEANING IN A FOREIGN LANGUAGE.

### CLASS 25—CLOTHING

FOR CLOTHES, NAMELY, T-SHIRTS, POLO SHIRTS, TANK TOPS, SWEATSHIRTS, SWEATERS, JACKETS, COATS, VESTS, PANTS, SHORTS, PAJAMAS, SOCKS, GLOVES, MITTENS, HATS, AND BANDANNAS (U.S. CLS. 22 AND 39).

### CLASS 35—ADVERTISING AND BUSINESS

FOR PROVIDING INCENTIVE, RECOGNITION, AND AWARD PROGRAMS FOR EMPLOYEES FOR THE PURPOSE OF PROMOTING AND IMPROVING CUSTOMER SERVICE, PERFORMANCE, PRODUCTIVITY, SALES, LOYALTY, TENURE, AND IDEAS; PROVIDING INCENTIVE AND AWARD PROGRAMS FOR CUSTOMERS FOR THE PURPOSE OF PROMOTING AND IMPROVING CUSTOMER LOYALTY, IDEAS, AND CUSTOMER FEEDBACK; PROVIDING INCENTIVE AND AWARD PROGRAMS FOR BUSINESSES BASED ON CUSTOMER FEEDBACK FOR THE PURPOSE OF PROMOTING AND IMPROVING CUSTOMER SERVICE, PERFORMANCE, PRODUCTIVITY SALES, LOYALTY, AND IDEA (U.S. CLS. 100, 101 AND 102).

### CLASS 42—SCIENTIFIC AND COMPUTER SERVICES

FOR COMPUTER SERVICES, NAMELY, DESIGNING, DEVELOPING, AND UPDATING COMPUTER SOFTWARE FOR OTHERS FOR PROVIDING INCENTIVE, LOYALTY, AND EMPLOYEE RECOGNITION PROGRAMS (U.S. CLS. 100 AND 101).

MEGHAN REINHART, EXAMINING ATTORNEY

SN 77-964,583. SAMFORD UNIVERSITY, BIRMINGHAM, AL. FILED 3-22-2010.



OWNER OF U.S. REG. NO. 2,028,504.  
NO CLAIM IS MADE TO THE EXCLUSIVE RIGHT TO USE "UNIVERSITY", APART FROM THE MARK AS SHOWN.

THE COLOR(S) RED AND BLUE IS/ARE CLAIMED AS A FEATURE OF THE MARK.

THE MARK CONSISTS OF THE STEEPLE AND WORDS, "SAMFORD UNIVERSITY" IN BLUE WITH A RED LINE BETWEEN THE TWO WORDS. WHITE IS NOT CLAIMED AS A COLOR AND IS TO INDICATE A TRANSPARENT AREA.

### CLASS 16—PAPER GOODS AND PRINTED MATTER

FOR PRINTED MATERIALS, NAMELY, NOTEBOOKS, REPORT COVERS, STATIONERY, HISTORICAL BOOKS AND PAMPHLETS AND EDUCATIONAL RECORDS, NAMELY, TRANSCRIPTS AND DIPLOMAS (U.S. CLS. 2, 5, 22, 23, 29, 37, 38 AND 50).

FIRST USE 7-1-2009; IN COMMERCE 7-1-2009.

**CLASS 41—EDUCATION AND ENTERTAINMENT**

FOR EDUCATIONAL SERVICES, NAMELY, PROVIDING COURSES OF INSTRUCTION AT THE UNDERGRADUATE, GRADUATE, AND COMMUNITY LEVELS; PROVIDING LECTURES, WORKSHOPS, SEMINARS AND CONFERENCES IN THE FIELDS OF LIBERAL ARTS, MEDICINE, BUSINESS, THEOLOGY, SCIENCE AND EDUCATION; PROVIDING LIVE PERFORMANCES BY BANDS, ORCHESTRAS AND SINGING GROUPS; ORGANIZING SPORTING EVENTS, NAMELY FOOTBALL, BASKETBALL, SOFTBALL, VOLLEYBALL, SOCCER, TRACK AND FIELD, CROSS COUNTRY, GOLF, TENNIS AND BASEBALL; AND THEATRICAL PRODUCTIONS FOR USE IN THE FINANCIAL AND MORAL SUPPORT OF HIGHER EDUCATION (U.S. CLS. 100, 101 AND 107).

FIRST USE 7-1-2009; IN COMMERCE 7-1-2009.  
DEZMONA MIZELLE, EXAMINING ATTORNEY

SN 77-966,717. SVETLANA FUCHS, LAS VEGAS, NV. FILED 3-23-2010.



THE MARK CONSISTS OF OVERLAPPING LETTERS "B" AND "M".

**CLASS 14—JEWELRY**

FOR BODY JEWELRY; BRACELETS; CHARMS; CUFFLINKS; JEWELRY; JEWELRY AND IMITATION JEWELRY; JEWELRY CHAINS; JEWELRY, NAMELY, CROSSES; KEY RINGS OF PRECIOUS METALS; PENDANTS; PINS BEING JEWELRY; RINGS; RINGS BEING JEWELRY; TIE BARS; TIE PINS; TIE TACKS (U.S. CLS. 2, 27, 28 AND 50).

FIRST USE 9-30-2009; IN COMMERCE 9-30-2009.

**CLASS 18—LEATHER GOODS**

FOR CARRY-ALL BAGS; DUFFEL BAGS; IMITATION LEATHER KEY CHAINS; LEATHER AND IMITATION LEATHER BAGS; LEATHER BAGS AND WALLETS; LEATHER BAGS, SUITCASES AND WALLETS; LEATHER CASES FOR KEYS; LEATHER CREDIT CARD CASES; LEATHER PURSES; MESSENGER BAGS; SHOULDER BAGS; SPORTS BAGS; TOTE BAGS; TRAVELLING BAGS; WALLETS MADE OF LEATHER OR OTHER MATERIALS (U.S. CLS. 1, 2, 3, 22 AND 41).

FIRST USE 9-30-2009; IN COMMERCE 9-30-2009.

**CLASS 25—CLOTHING**

FOR BASEBALL CAPS AND HATS; BELTS; BELTS MADE OF LEATHER; BOMBER JACKETS; BOTTOMS; CAPS; DENIM JACKETS; DENIMS; DRESS SHIRTS; DRESSES; FOULARDS; GLOVES AS CLOTHING; HATS; HEAD SCARVES; HEADBANDS FOR CLOTHING; HOODED PULLOVERS; HOODED SWEAT SHIRTS; HOODS; JACKET LINERS; JACKETS; JACKETS AND SOCKS; JEANS; JERSEYS; LEATHER BELTS; LEATHER COATS; LEATHER JACKETS; LEATHER PANTS; LEATHER SHOES; LEGGINGS; MEN'S AND WOMEN'S JACKETS, COATS, TROUSERS, VESTS; OUTER JACKETS; PANTS; SCARVES; SHIRTS; SHOES; SILK SCARVES; SKIRTS AND DRESSES; SLEEVED OR SLEEVELESS JACKETS; SWEAT JACKETS; SWEAT SHIRTS; SWEAT SUITS; T-SHIRTS; TIES; TOPS; VESTS (U.S. CLS. 22 AND 39).

FIRST USE 9-30-2009; IN COMMERCE 9-30-2009.  
PAM WILLIS, EXAMINING ATTORNEY

SN 77-965,913. EASY BUS RENTAL, LLC, GLOUCESTER, MA. FILED 3-23-2010.

**GROUPIZE**

THE MARK CONSISTS OF STANDARD CHARACTERS WITHOUT CLAIM TO ANY PARTICULAR FONT, STYLE, SIZE, OR COLOR.

**CLASS 39—TRANSPORTATION AND STORAGE**

FOR TRAVEL AGENCY SERVICES, NAMELY, MAKING RESERVATIONS AND BOOKINGS FOR TRANSPORTATION; CHARTERING OF BUSES, MOTOR COACHES AND LIMOUSINES; ORGANIZATION, BOOKING AND ARRANGEMENT OF EXCURSIONS, DAY TRIPS, AND SIGHTSEEING TOURS; TOUR GUIDE SERVICES; TRAVEL GUIDE AND TRAVEL INFORMATION SERVICES; ARRANGING GROUP TRAVEL TOURS VIA THE INTERNET; ONLINE TRIP AND TRAVEL RESERVATION SERVICES; PROVIDING INFORMATION CONCERNING TRAVEL, TRAVEL NEWS AND TRAVEL-RELATED TOPICS NOT INCLUDING INFORMATION RELATED TO TEMPORARY ACCOMMODATIONS OR LODGING VIA ELECTRONIC COMMUNICATION NETWORKS (U.S. CLS. 100 AND 105).

**CLASS 43—HOTEL AND RESTAURANT SERVICES**

FOR PROVIDING TRAVEL LODGING INFORMATION SERVICES AND TRAVEL LODGING BOOKING AGENCY SERVICES FOR TRAVELERS VIA THE INTERNET (U.S. CLS. 100 AND 101).

JIM RINGLE, EXAMINING ATTORNEY

SN 77-967,635. PEYRON, BRUNO, FR-44350 GUERANDE, FRANCE, FILED 3-24-2010.



OWNER OF FRANCE REG. NO. 96652202, DATED 11-25-1996, RENEWED AS REG. NO. 96652202, DATED 11-22-2006, EXPIRES 11-25-2016.

NO CLAIM IS MADE TO THE EXCLUSIVE RIGHT TO USE "RACE" AS TO CLASSES 009 & 041 ONLY, APART FROM THE MARK AS SHOWN.

THE COLOR(S) BLACK, GRAY, WHITE AND RED IS/ ARE CLAIMED AS A FEATURE OF THE MARK.

THE MARK CONSISTS OF THE WORDING "THE RACE" IN THE COLOR GRAY CONTAINED WITHIN A BLACK RECTANGLE WITH A STYLIZED GLOBE DESIGN INTERSECTING THE BOTTOM CENTER PORTION OF THE RECTANGLE. THE STYLIZED GLOBE DESIGN IS SLIGHTLY OVERLAPPING THE LOWER PORTION OF THE LETTER "E" IN THE WORD "THE" AND THE LETTER "R" IN THE WORD "RACE". THE STYLIZED GLOBE DESIGN IS COLORED RED WITH SHADING OF BLACK AND WHITE.

#### **CLASS 9—ELECTRICAL AND SCIENTIFIC APPARATUS**

FOR APPARATUS FOR RECORDING, TRANSMISSION OR REPRODUCTION OF SOUND AND IMAGES; BLANK MAGNETIC DATA CARRIERS; PRERECORDED MAGNETIC DATA CARRIERS FEATURING MARITIME RACE SOUNDS AND IMAGES; BLANK COMPUTER DISCS FOR RECORDING SOUND AND IMAGES; COMPACT DISCS, AUDIO TAPES, VIDEO TAPES, MOTION PICTURE FILMS, ALL FEATURING MARITIME RACES; DATA PROCESSORS; COMPUTERS; COMPUTER GAME SOFTWARE; INTERACTIVE GAME SOFTWARE AND PROGRAMS; INTERACTIVE VIDEO GAME PROGRAMS; COMPUTER HARDWARE; AMUSEMENT APPARATUS AND GAMES IN THE NATURE OF ELECTRONIC GAMES AND VIDEO GAMES ADAPTED FOR USE WITH TELEVISIONS OR WITH VIDEO EQUIPMENT (U.S. CLS. 21, 23, 26, 36 AND 38).

#### **CLASS 25—CLOTHING**

FOR CLOTHING, NAMELY, SHIRTS, TROUSERS, JACKETS, SHORTS, SOCKS, UNDERWEAR, T-SHIRTS, DRESSES, GLOVES, SWIM SUITS, COATS, PARKAS, SWEAT SUITS; FOOTWEAR; HEADWEAR (U.S. CLS. 22 AND 39).

#### **CLASS 41—EDUCATION AND ENTERTAINMENT**

FOR ENTERTAINMENT SERVICES IN THE NATURE OF MARITIME RACES; ENTERTAINMENT SERVICES IN THE NATURE OF ORGANIZING MARITIME RACING AND EXHIBITIONS; ORGANIZING SPORTING EVENTS, NAMELY, MARITIME RACES; ENTERTAINMENT IN THE NATURE OF ORGANIZING A CULTURAL FESTIVAL IN THE FIELD OF SPORTING EVENTS; ORGANIZING COMMUNITY SPORTING AND CULTURAL EVENTS; PUBLISHING OF BOOKS, MAGAZINES; EDUCATIONAL SERVICES, NAMELY, PROVIDING COURSES IN THE FIELD OF MARITIME RACING AND TRAINING SERVICES IN THE USE OF RACING BOATS; ENTERTAINMENT SERVICES, NAMELY, CONDUCTING CONTESTS RELATING TO MARITIME RACES; ORGANIZATION OF EXHIBITIONS AND SHOWS FOR CULTURAL OR EDUCATIONAL PURPOSES (U.S. CLS. 100, 101 AND 107).

ALICIA COLLINS, EXAMINING ATTORNEY

SN 77-967,745. ESSENTIAL BRANDS, INC., ABINGDON, MD. FILED 3-24-2010.

### **PARENTING ESSENTIALS**

THE MARK CONSISTS OF STANDARD CHARACTERS WITHOUT CLAIM TO ANY PARTICULAR FONT, STYLE, SIZE, OR COLOR.

OWNER OF U.S. REG. NO. 3,610,064.

NO CLAIM IS MADE TO THE EXCLUSIVE RIGHT TO USE "PARENTING", APART FROM THE MARK AS SHOWN.

#### **CLASS 41—EDUCATION AND ENTERTAINMENT**

FOR PROVIDING INFORMATION IN THE FIELD OF PARENTING CONCERNING EDUCATION OF CHILDREN; PROVIDING ONLINE PUBLICATIONS IN THE FIELDS OF PARENTING, EARLY CHILDHOOD EDUCATION, CHILD DAY CARE CENTER SERVICES, EARLY CHILDHOOD EDUCATION AND CHILD DAY CARE METHODS AND SYSTEMS (U.S. CLS. 100, 101 AND 107).

FIRST USE 4-0-2009; IN COMMERCE 4-0-2009.

#### **CLASS 44—MEDICAL, BEAUTY AND AGRICULTURAL SERVICES**

FOR INFORMATION IN THE FIELD OF PARENTING CONCERNING THE HEALTH AND MENTAL HEALTH OF CHILDREN (U.S. CLS. 100 AND 101).

FIRST USE 4-0-2009; IN COMMERCE 4-0-2009.

#### **CLASS 45—PERSONAL AND LEGAL SERVICES**

FOR PROVIDING INFORMATION IN THE FIELD OF PARENTING CONCERNING INTRAFAMILY RELATIONSHIPS (U.S. CLS. 100 AND 101).

FIRST USE 4-0-2009; IN COMMERCE 4-0-2009.

MARCIE MILONE, EXAMINING ATTORNEY

SN 77-968,209. PRINT MEDIA ASSOCIATES, INC., CHARLOTTE, NC. FILED 3-25-2010.



NO CLAIM IS MADE TO THE EXCLUSIVE RIGHT TO USE "PRINT", APART FROM THE MARK AS SHOWN.

THE MARK CONSISTS OF AN LINE OUTLINE OF A CITY SKYLINE WITH THE WORDS "SOUTH CITY PRINT" BENEATH IT.

#### **CLASS 35—ADVERTISING AND BUSINESS**

FOR DOCUMENT REPRODUCTION SERVICES; PHOTOCOPYING SERVICES; MAIL SERVICES, NAMELY, RECEIVING AND PROCESSING OF DOMESTIC AND INTERNATIONAL MAIL FOR INFUSION INTO ESTABLISHED POSTAL SERVICES AS REGULAR MAIL AND AS BULK MAIL; PREPARING MAILING LISTS; COPYING DOCUMENTS FOR CORPORATE AND BUSINESS CLIENTS; DATA PROCESSING SERVICES; ONLINE RETAIL MAIL ORDER SERVICES IN THE FIELD OF CUSTOMIZED STATIONERY, BUSINESS FORMS AND BUSINESS CARDS; MANAGEMENT AND OPERATION ASSISTANCE TO COMMERCIAL BUSINESSES IN THE NATURE OF MANAGEMENT OF COPYING AND PRINTING OPERATIONS FOR CORPORATE AND BUSINESS CLIENTS (U.S. CLS. 100, 101 AND 102).

FIRST USE 3-22-2010; IN COMMERCE 3-22-2010.

#### **CLASS 40—MATERIAL TREATMENT**

FOR DOCUMENT BINDING, NAMELY, BINDING OF HARD AND SOFT COVER BOOKS FOR OTHERS; PRINTING SERVICES; DESIGN PRINTING FOR OTHERS; OFFSET PRINTING; TYPESETTING SERVICES, NAMELY, LASER TYPESETTING AND DISK TO LASER TYPESETTING; DIGITAL PHOTO PRINTING SERVICES; PHOTOGRAPHIC PRINTING (U.S. CLS. 100, 103 AND 106).

FIRST USE 3-22-2010; IN COMMERCE 3-22-2010.

**CLASS 42—SCIENTIFIC AND COMPUTER SERVICES**

FOR MEDIA DUPLICATION OF DATA AND DIGITAL INFORMATION; GRAPHICS ART DESIGN; COMPUTER-AIDED GRAPHIC DESIGN; DESIGN AND CREATION OF WEBSITES FOR OTHERS; GRAPHIC ILLUSTRATION FOR OTHERS; CONVERSION OF DATA OR PRINTED DOCUMENTS FROM PHYSICAL TO ELECTRONIC MEDIA (U.S. CLS. 100 AND 101).

FIRST USE 3-22-2010; IN COMMERCE 3-22-2010.  
SUSAN RICHARDS, EXAMINING ATTORNEY

**CLASS 9—ELECTRICAL AND SCIENTIFIC APPARATUS**

FOR DIGITAL MEDIA, NAMELY, PRE-RECORDED VIDEO CASSETTES, DIGITAL VIDEO DISCS, DIGITAL VERSATILE DISCS, DOWNLOADABLE AUDIO AND VIDEO RECORDINGS, DVDS, AND HIGH DEFINITION DIGITAL DISCS FEATURING FILM AND TELEVISION CONTAINING ACTION/ADVENTURE, SCIENCE FICTION AND FANTASY CONTENT AND VIDEO GAMES; INTERACTIVE GAME SOFTWARE (U.S. CLS. 21, 23, 26, 36 AND 38).

**CLASS 41—EDUCATION AND ENTERTAINMENT**

FOR ENTERTAINMENT SERVICES IN THE NATURE OF DEVELOPMENT, CREATION, PRODUCTION AND POST-PRODUCTION SERVICES OF MULTIMEDIA ENTERTAINMENT CONTENT (U.S. CLS. 100, 101 AND 107).  
LINDA MICKLEBURGH, EXAMINING ATTORNEY

SN 77-969,576. KILLSPACE ENTERTAINMENT INC., CALABASAS, CA. FILED 3-26-2010.

SN 77-969,673. KILLSPACE ENTERTAINMENT INC., CALABASAS, CA. FILED 3-26-2010.

**Clockwork**

**Recursive**

THE MARK CONSISTS OF STANDARD CHARACTERS WITHOUT CLAIM TO ANY PARTICULAR FONT, STYLE, SIZE, OR COLOR.

THE MARK CONSISTS OF STANDARD CHARACTERS WITHOUT CLAIM TO ANY PARTICULAR FONT, STYLE, SIZE, OR COLOR.

**CLASS 9—ELECTRICAL AND SCIENTIFIC APPARATUS**

FOR DIGITAL MEDIA, NAMELY, PRE-RECORDED VIDEO CASSETTES, DIGITAL VIDEO DISCS, DIGITAL VERSATILE DISCS, DOWNLOADABLE AUDIO AND VIDEO RECORDINGS, DVDS, AND HIGH DEFINITION DIGITAL DISCS FEATURING FILM, TELEVISION CONTAINING ACTION/ADVENTURE, SCIENCE FICTION AND FANTASY CONTENT AND VIDEO GAMES; INTERACTIVE GAME SOFTWARE (U.S. CLS. 21, 23, 26, 36 AND 38).

**CLASS 9—ELECTRICAL AND SCIENTIFIC APPARATUS**

FOR DIGITAL MEDIA, NAMELY, PRE-RECORDED VIDEO CASSETTES, DIGITAL VIDEO DISCS, DIGITAL VERSATILE DISCS, DOWNLOADABLE AUDIO AND VIDEO RECORDINGS, DVDS, AND HIGH DEFINITION DIGITAL DISCS FEATURING FILM AND TELEVISION CONTAINING ACTION/ADVENTURE, SCIENCE FICTION AND FANTASY CONTENT AND VIDEO GAMES; INTERACTIVE GAME SOFTWARE (U.S. CLS. 21, 23, 26, 36 AND 38).

**CLASS 41—EDUCATION AND ENTERTAINMENT**

FOR ENTERTAINMENT SERVICES IN THE NATURE OF DEVELOPMENT, CREATION, PRODUCTION AND POST-PRODUCTION SERVICES OF MULTIMEDIA ENTERTAINMENT CONTENT (U.S. CLS. 100, 101 AND 107).  
LINDA MICKLEBURGH, EXAMINING ATTORNEY

**CLASS 41—EDUCATION AND ENTERTAINMENT**

FOR ENTERTAINMENT SERVICES IN THE NATURE OF DEVELOPMENT, CREATION, PRODUCTION AND POST-PRODUCTION SERVICES OF MULTIMEDIA ENTERTAINMENT CONTENT (U.S. CLS. 100, 101 AND 107).  
LINDA MICKLEBURGH, EXAMINING ATTORNEY

SN 77-969,590. KILLSPACE ENTERTAINMENT INC., CALABASAS, CA. FILED 3-26-2010.

SN 77-969,703. KILLSPACE ENTERTAINMENT INC., CALABASAS, TX. FILED 3-26-2010.

**Clockwork Creations**

**Recursive Studio**

THE MARK CONSISTS OF STANDARD CHARACTERS WITHOUT CLAIM TO ANY PARTICULAR FONT, STYLE, SIZE, OR COLOR.

THE MARK CONSISTS OF STANDARD CHARACTERS WITHOUT CLAIM TO ANY PARTICULAR FONT, STYLE, SIZE, OR COLOR.  
NO CLAIM IS MADE TO THE EXCLUSIVE RIGHT TO USE "STUDIO", APART FROM THE MARK AS SHOWN.

**CLASS 9—ELECTRICAL AND SCIENTIFIC APPARATUS**

FOR DIGITAL MEDIA, NAMELY, PRE-RECORDED VIDEO CASSETTES, DIGITAL VIDEO DISCS, DIGITAL VERSATILE DISCS, DOWNLOADABLE AUDIO AND VIDEO RECORDINGS, DVDS, AND HIGH DEFINITION DIGITAL DISCS FEATURING FILM AND TELEVISION CONTAINING ACTION/ADVENTURE, SCIENCE FICTION AND FANTASY CONTENT AND VIDEO GAMES; INTERACTIVE GAME SOFTWARE (U.S. CLS. 21, 23, 26, 36 AND 38).

**CLASS 41—EDUCATION AND ENTERTAINMENT**

FOR ENTERTAINMENT SERVICES IN THE NATURE OF DEVELOPMENT, CREATION, PRODUCTION AND POST-PRODUCTION SERVICES OF MULTIMEDIA ENTERTAINMENT CONTENT (U.S. CLS. 100, 101 AND 107).  
LINDA MICKLEBURGH, EXAMINING ATTORNEY

SN 77-970,077. CRUISER CUSTOMIZING, INC., LIVERMORE, CA. FILED 3-26-2010.

**CRUISER CUSTOMIZING**

THE MARK CONSISTS OF STANDARD CHARACTERS WITHOUT CLAIM TO ANY PARTICULAR FONT, STYLE, SIZE, OR COLOR.

NO CLAIM IS MADE TO THE EXCLUSIVE RIGHT TO USE "CRUISER" IN INTERNATIONAL CLASS 42, APART FROM THE MARK AS SHOWN.

SEC. 2(F).

THE 2(F) CLAIM IS RESTRICTED TO CLASS(ES) 35

**CLASS 35—ADVERTISING AND BUSINESS**

FOR ON-LINE RETAIL STORE SERVICES FEATURING MOTORCYCLE PARTS AND ACCESSORIES (U.S. CLS. 100, 101 AND 102).

FIRST USE 7-20-2001; IN COMMERCE 7-20-2001.

**CLASS 42—SCIENTIFIC AND COMPUTER SERVICES**

FOR HOSTING AN ON-LINE COMMUNITY WEB SITE FEATURING TOPICS OF INTEREST TO MOTORCYCLE AFICIONADOS (U.S. CLS. 100 AND 101).

FIRST USE 9-30-2008; IN COMMERCE 9-30-2008.

BRENDAN MCCAULEY, EXAMINING ATTORNEY

SN 77-981,337. AMERICAN SPECIALTIES, INC., YONKERS, NY. FILED 6-29-2009.

**ROVAL**

THE MARK CONSISTS OF STANDARD CHARACTERS WITHOUT CLAIM TO ANY PARTICULAR FONT, STYLE, SIZE, OR COLOR.

**CLASS 6—METAL GOODS**

FOR DISPENSERS MADE PRIMARILY OF METAL, NAMELY, TOWEL DISPENSERS, SANITARY NAPKIN DISPENSERS, TOILET SEAT COVER DISPENSERS (U.S. CLS. 2, 12, 13, 14, 23, 25 AND 50).

FIRST USE 11-0-2009; IN COMMERCE 11-0-2009.

**CLASS 21—HOUSEWARES AND GLASS**

FOR TOILET TISSUE DISPENSERS AND SOAP DISPENSERS MADE PRIMARILY OF METAL; WASTE PAPER RECEPTACLES MADE PRIMARILY OF METAL; WASTE RECEPTACLES MADE PRIMARILY OF METAL (U.S. CLS. 2, 13, 23, 29, 30, 33, 40 AND 50).

FIRST USE 11-0-2009; IN COMMERCE 11-0-2009.

JAMES GRIFFIN, EXAMINING ATTORNEY

SN 78-149,064. DOMINGUE, STEPHEN, HERMOSA BEACH, CA. FILED 7-30-2002.

**FOUR-PEAT SAKES****CLASS 21—HOUSEWARES AND GLASS**

FOR COLLECTABLE PLATES, MUGS, AND TANKARDS (U.S. CLS. 2, 13, 23, 29, 30, 33, 40 AND 50).

**CLASS 25—CLOTHING**

FOR SHIRTS, JACKETS, AND HATS (U.S. CLS. 22 AND 39).

SHARON MEIER, EXAMINING ATTORNEY

SN 78-649,739. CORPORACIÓN BELLEZA JUVENIL, S.A., SAN JOSE, COSTA RICA, FILED 6-13-2005.



NO CLAIM IS MADE TO THE EXCLUSIVE RIGHT TO USE "COSMETICS", APART FROM THE MARK AS SHOWN.

THE COLOR(S) BLACK, WHITE, AND GREEN IS/ARE CLAIMED AS A FEATURE OF THE MARK.

THE COLOR GREEN APPEARS IN THE LETTER "I" IN THE TERM "DION"; THE COLOR WHITE APPEARS IN THE WORD "COSMETICS", THE LETTERS "D" AND "ON" OF THE WORD "DION"; AND THE COLOR BLACK APPEARS IN THE BACKGROUND OF THE SQUARE.



**CLASS 3—COSMETICS AND CLEANING PREPARATIONS**

FOR PERFUMES, EAU DE TOILET, TOILET SOAPS; COSMETICS, NAMELY, DEODORANTS FOR PERSONAL USE, CREAMS, LOTIONS AND OIL FOR THE FACE AND THE BODY; CLEANSING MILKS, CREAMS AND OILS; MAKE-UP CREAMS, BEAUTY MASKS, MAKE-UP REMOVERS, EYE SHADOWS; LIPSTICKS, LIP GLOSS; CRAYONS FOR THE EYES AND THE LIPS, MASCARA; ROUGE AND FACE POWDERS; CREAMS, OILS AND LOTIONS FOR SUNTANNING AND AFTER-SUN EXPOSURE; PRE- AND AFTER-SHAVE LOTIONS; TALCUM POWDERS; NON-MEDICATED BATH SALTS; FOAM AND OIL BATH; AFTER-BATH CREAMS AND LOTIONS; DEPILATORY PREPARATIONS, NAMELY, DEPILATORY CREAMS AND LOTIONS; NAIL POLISHES, SHAMPOOS, CUTICLE CONDITIONERS, HAIR CONDITIONERS, HAIR LOTIONS, HAIR CARE LOTIONS, HAIR WAVING LOTIONS, DENTIFRICES (U.S. CLS. 1, 4, 6, 50, 51 AND 52).

**CLASS 5—PHARMACEUTICALS**

FOR DEODORANTS OTHER THAN FOR PERSONAL USE, NAMELY, AIR DEODORANTS, ALL-PURPOSE DEODORIZING PREPARATIONS, CAR DEODORANT, CURTAIN DEODORANTS, DRAPERY DEODORANTS; SANITARY PREPARATIONS, NAMELY, ANTISEPTICS, ANTIBACTERIAL HANDWASH; DIAGNOSTIC PREPARATIONS FOR MEDICAL USE; OTHER PHARMACEUTICALS, NAMELY, ASTRINGENTS, PHARMACEUTICAL SKIN LOTIONS AND PHARMACEUTICAL PREPARATIONS FOR WOUNDS; FIRST AID KITS CONTAINING ANTISEPTIC SOLUTIONS, GAUZE, BANDAGES AND OTHER FIRST AID PRODUCTS; DIETARY AND NUTRITIONAL SUPPLEMENTS (U.S. CLS. 6, 18, 44, 46, 51 AND 52).

MARY ROSSMAN, EXAMINING ATTORNEY

SN 78-802,832. AEG LIVE, LLC, LOS ANGELES, CA. FILED 1-30-2006.

**NETWORK LIVE**

THE MARK CONSISTS OF STANDARD CHARACTERS WITHOUT CLAIM TO ANY PARTICULAR FONT, STYLE, SIZE, OR COLOR.

NO CLAIM IS MADE TO THE EXCLUSIVE RIGHT TO USE "LIVE", APART FROM THE MARK AS SHOWN. SEC. 2(F).

**CLASS 38—COMMUNICATION**

FOR STREAMING OF LIVE AND RECORDED AUDIO AND AUDIOVISUAL CONTENT VIA THE INTERNET AND MOBILE DEVICES; BROADCASTING OF AUDIO AND AUDIOVISUAL CONTENT VIA THE INTERNET, MOBILE DEVICES, COMPUTING DEVICES, TELEVISION, RADIO, AND SATELLITE RADIO (U.S. CLS. 100, 101 AND 104).

FIRST USE 9-19-2005; IN COMMERCE 9-19-2005.

**CLASS 41—EDUCATION AND ENTERTAINMENT**

FOR PROVIDING TICKETS FOR VARIOUS ENTERTAINMENT SHOWS AND EVENTS; AND ENTERTAINMENT SERVICES, NAMELY, PRODUCING, DIRECTING, AND DISTRIBUTION FOR OTHERS, OF LIVE AND RECORDED AUDIOVISUAL PROGRAMMING IN THE FIELDS OF ENTERTAINMENT, MUSIC, COMEDY, DRAMA, AND NEWS (U.S. CLS. 100, 101 AND 107).

FIRST USE 9-19-2005; IN COMMERCE 9-19-2005.

ROBIN CHOSID, EXAMINING ATTORNEY

SN 78-921,505. DICKHOUSE ENTERTAINMENT, INC., BEVERLY HILLS, CA. FILED 6-30-2006.



THE COLOR(S) RED, ORANGE, YELLOW, GREEN, LIGHT BLUE, DARK BLUE, PURPLE AND BLACK IS/ARE CLAIMED AS A FEATURE OF THE MARK.

THE MARK CONSISTS OF A STYLIZED RAINBOW OF THE COLORS: RED, ORANGE, YELLOW, GREEN, LIGHT BLUE, DARK BLUE AND PURPLE WITH THE WORD "DICKHOUSE" IN BLACK BELOW THE RAINBOW.

**CLASS 25—CLOTHING**

FOR SHIRTS, BANDANNAS, PANTS, CAPS, HATS, VISORS, FOOTWEAR, JACKETS, UNDERWEAR, BELTS AND PAJAMAS (U.S. CLS. 22 AND 39).

**CLASS 41—EDUCATION AND ENTERTAINMENT**

FOR TELEVISION AND MOTION PICTURE PRODUCTION SERVICES (U.S. CLS. 100, 101 AND 107).

TINA L. SNAPP, EXAMINING ATTORNEY

SN 79-056,855. TOM TAILOR GMBH, FED REP GERMANY, FILED 12-5-2007.



OWNER OF INTERNATIONAL REGISTRATION 0925686 DATED 2-12-2007, EXPIRES 2-12-2017.

OWNER OF U.S. REG. NOS. 2,945,474, 3,024,986 AND OTHERS.

NO CLAIM IS MADE TO THE EXCLUSIVE RIGHT TO USE "DENIM", APART FROM THE MARK AS SHOWN.

"TOM TAILOR" DOES NOT IDENTIFY A LIVING INDIVIDUAL.

THE MARK CONSISTS OF THE STYLIZED WORDING "TOM TAILOR DENIM" ON A SOLID RECTANGULAR BACKGROUND.

**CLASS 9—ELECTRICAL AND SCIENTIFIC APPARATUS**

FOR OPTICS, NAMELY, SPECTACLES; SPECTACLE FRAMES; SPECTACLE CASES; SPECTACLE GLASSES; SUNGLASSES (U.S. CLS. 21, 23, 26, 36 AND 38).

**CLASS 14—JEWELRY**

FOR JEWELLERY, NAMELY, BRACELET; WRIST-WATCHES; JEWELLERY, NAMELY, BROOCHES; GOODS MADE OF PRECIOUS METALS AND THEIR ALLOYS OR PLATED THEREWITH, NAMELY, BADGES, BOXES, JEWEL CASES, PRECIOUS STONES; ORNAMENTS OF UNWROUGHT OR SEMI-WROUGHT JET; JEWELLERY, NAMELY, NECKLACES; HAT ORNAMENTS OF PRECIOUS METAL; JEWELLERY; TIE CLIPS; TIE PINS; JEWELLERY, NAMELY, MEDALLIONS; EARRINGS; JEWELLERY, NAMELY, PEARLS; PEARLS MADE OF AMBEROID, NAMELY, PRESSED AMBER; JEWELLERY, NAMELY, RINGS; KEY RING TRINKETS AND KEY RING FOBS OF PRECIOUS METAL; SHOE ORNAMENTS OF PRECIOUS METAL; ORNAMENTS OF PRECIOUS METAL; WATCHES; HOROLOGICAL AND CHRONOMETRIC INSTRUMENTS; CLOCKS; CASES FOR CLOCKS AND WATCHES (U.S. CLS. 2, 27, 28 AND 50).

**CLASS 16—PAPER GOODS AND PRINTED MATTER**

FOR PICTURES; PRINTED MATTER, NAMELY, BOOKS, BROCHURES, GREETING CARDS, POSTCARDS, PICTURES, CALENDARS ALL IN THE FIELD OF FASHION AND LIFESTYLE, BOOKLETS IN THE FIELD OF FASHION AND LIFESTYLE; PICTURE POST CARDS, INFORMATIONAL FLYERS IN THE FIELD OF FASHION AND LIFESTYLE; MAGAZINE INSERTS IN THE NATURE OF PRINTED ADVERTISEMENTS PRODUCED FOR OTHERS IN THE FIELD OF FASHION AND LIFESTYLE; PENHOLDERS; PEN CASES; CATALOGUES IN THE FIELD OF FASHION AND LIFESTYLE; PRINTED CHARTS; MAGAZINES, NAMELY, PERIODICALS FEATURING FASHION AND LIFESTYLE; GOODS MADE OF PAPER AND CARDBOARD, NAMELY, PAPER BAGS, GIFT BOXES MADE OF PAPER OR CARDBOARD, PAPER BADGES, PAPER BOARDS, PAPER BOWS FOR GIFT WRAP, PAPER PARTY DECORATIONS, PAPER DISPLAY BOXES, AGENDAS, PRICE TAGS, PAPER FLAGS, PAPER PLACE MATS, PAPER COASTERS, PAPER BOTTLE WRAPPERS; PAPER FOR INDUSTRIAL USE; PHOTOGRAPHS; POSTERS; NEWSLETTERS IN THE FIELD OF FASHION AND LIFESTYLE; STATIONERY; RUBBER STAMPS; BOXES OF CARDBOARD OR PAPER; PRINTED PUBLICATIONS, NAMELY, BROCHURES, BOOKLETS AND TEACHING MATERIALS IN THE FIELD OF FASHION AND LIFESTYLE; BOTTLE WRAPPERS OF CARDBOARD OR PAPER; PLASTIC OR PAPER BAGS, ENVELOPES AND POUCHES FOR MERCHANDISE PACKAGING; PLASTIC FILMS FOR WRAPPING, NOT FOR COMMERCIAL OR INDUSTRIAL PURPOSES; SHEETS OF RECLAIMED CELLULOSE FOR WRAPPING, NAMELY, FOR MERCHANDISE PACKAGING; CARDBOARD ARTICLES, NAMELY, CARDBOARD CARTONS, CARDBOARD BAGS, CARDBOARD BOXES, GIFT WRAPPING CARDBOARD, GIFT BOXES MADE OF CARDBOARD, CARDBOARD CARTONS, CARDBOARD CONTAINERS, CARDBOARD DIVIDERS FOR BOXES, CARDBOARD FOLDERS, CARDBOARD CARTONS FOR DELIVERING GOODS, CARRYING CASES MADE OF CARDBOARD; PACKAGING MATERIAL OF PAPER, NAMELY, PACKAGING PAPER; GIFT WRAPPING PAPER; NEWSPAPERS (U.S. CLS. 2, 5, 22, 23, 29, 37, 38 AND 50).

**CLASS 18—LEATHER GOODS**

FOR BRIEFCASES; POCKET WALLETS OF DENIM; DENIM ATTACHE CASES; ANIMAL SKINS; DENIM PURSES; DENIM HANDBAGS; SUITCASES; ANIMAL HIDES; DENIM VANITY CASES NOT FITTED; GOODS MADE OF LEATHER AND IMITATION LEATHER, NAMELY, TOTE BAGS, KNAPSACKS; LEATHER GOODS FOR HOUSEHOLD USE, NAMELY, LEATHER BOXES, CASES; UNFITTED DENIM FURNITURE COVERINGS; TRAVELLING TRUNKS; UMBRELLAS, PARASOLS AND WALKING STICKS; DENIM RUCKSACKS; WHEELED DENIM SHOPPING BAGS (U.S. CLS. 1, 2, 3, 22 AND 41).

**CLASS 25—CLOTHING**

FOR SUITS; WORKING CLOTHES, NAMELY, PANTS, APRONS, SMOCKS, COVERALLS, VESTS; CLOTHING, NAMELY, CHAPS, BLOUSES; FRÖCKS; BELTS; JEANS; JACKETS; SCARVES; TROUSERS; HOT PANTS; HATS; HEAD BANDANAS, HEAD SCARVES, CLOTHING FOR CHILDREN, NAMELY, SWEATERS, PANTS, SKIRTS, T-SHIRTS, DRESSES, SHIRTS, JACKETS; COATS; CAPS; CAP PEAKS; PARKAS; FOOTWEAR; SHAWLS; COMBINATIONS CLOTHING, NAMELY, OVERALLS, DRESSES FOR WEARING TO WORK, SHORTS, SHIRTS; OVERALLS; SHOES; BOOTS; OVERCOATS; WAISTCOATS; ALL OF THE AFOREMENTIONED GOODS ARE MADE IN WHOLE OR SUBSTANTIALLY IN PART OF DENIM (U.S. CLS. 22 AND 39).

ALYSSA STEEL, EXAMINING ATTORNEY

SN 79-058,224. FMR - ART' E' S.P.A., ITALY, FILED 2-11-2008.

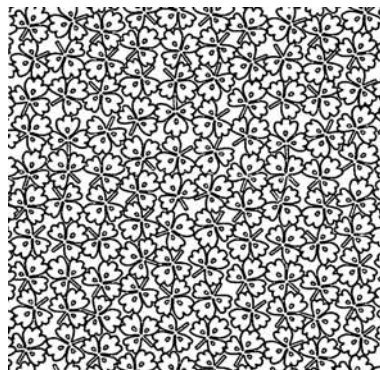

PRIORITY DATE OF 10-16-2007 IS CLAIMED.  
OWNER OF INTERNATIONAL REGISTRATION 0975707  
DATED 2-11-2008, EXPIRES 2-11-2018.

THE MARK IS A COMPLEX STRUCTURE AS IT CONSISTS OF A SERIES OF LEAVES PLACED ON DIFFERENT LEVELS; EACH LEAF CONSISTS OF THREE SMALL STYLISED LEAVES.

**CLASS 35—ADVERTISING AND BUSINESS**

FOR BUSINESS SERVICES, NAMELY, BUSINESS CONSULTATION; BUSINESS ACQUISITIONS CONSULTATION; BUSINESS DEVELOPMENT SERVICES, NAMELY, PROVIDING START-UP SUPPORT AND BUSINESS INQUIRIES FOR BUSINESSES; BUSINESS ORGANIZATION AND BUSINESS ECONOMIC CONSULTING; CONSULTING CONCERNING OPERATION, ADMINISTRATION AND MANAGEMENT OF COMMERCIAL COMPANIES; ADVICE AND ASSISTANCE IN CONNECTION WITH MANAGEMENT OF BUSINESS ACTIVITIES; PROVIDING BUSINESS ADVICE CONCERNING COMMERCIAL MERGERS, ACQUISITIONS, FRANCHISES AND LIQUIDATIONS; BUSINESS MANAGEMENT CONSULTATION CONCERNING SALES AND ACQUISITIONS OF COMPANIES, INCORPORATION OF COMPANIES AND COMMERCIAL INVESTIGATIONS (U.S. CLS. 100, 101 AND 102).

**CLASS 39—TRANSPORTATION AND STORAGE**

FOR TRANSPORT AND STORAGE OF GOODS; PASSENGER TRANSPORT SERVICES; SERVICES PROVIDED BY COMPANIES OPERATING STATIONS OR BRIDGES USED BY THOSE INVOLVED IN TRANSPORT, NAMELY, BRIDGE OPERATION; RENTAL SERVICES FOR TRANSPORT VEHICLES; MARINE TOWING, CARGO UNLOADING, MANAGEMENT OF PORTS AND DOCKS IN THE NATURE OF RESCUE OF SHIPS IN DANGER AND UNLOADING THEREOF; AIRPORT SERVICES; PACKAGING OF GOODS BEFORE SHIPMENT; PROVISION OF TRAVEL INFORMATION AND TRANSPORTATION OF GOODS INFORMATION PROVIDED BY BROKERS AND TRAVEL AGENCIES; PROVISION OF INFORMATION IN THE FIELD OF TRANSPORTATION AND RELATED TARIFFS AND TIMETABLES (U.S. CLS. 100 AND 105).

**CLASS 41—EDUCATION AND ENTERTAINMENT**

FOR EDUCATIONAL SERVICES, NAMELY, INSTRUCTION IN THE FIELD OF ART HISTORY; EDUCATIONAL SERVICES, NAMELY, TEACHING IN THE FIELD OF REMEDIAL READING; EDUCATIONAL SERVICES, NAMELY, SEMINARS IN THE FIELD OF ART; SERVICES RENDERED BY PUBLISHERS, NAMELY, BOOK AND PERIODICAL PUBLISHING; PUBLISHING OF ELECTRONIC PUBLICATIONS; DESKTOP PUBLISHING FOR OTHERS; PUBLICATION OF BOOKS, MAGAZINES AND PERIODICALS; PUBLICATION OF PRINTED MATTER, NAMELY, BROCHURES, CATALOGUES, BOOKS, JOURNALS, NEWSPAPERS; PUBLICATION OF TEXT; ONLINE ELECTRONIC PUBLISHING OF BOOKS AND PERIODICALS ACCESSIBLE VIA COMPUTER DATABANKS OR VIA THE INTERNET; PUBLISHING OF ELECTRONIC PUBLICATIONS RECORDED ON MAGNETIC OR OPTICAL DATA MEDIA; MULTIMEDIA PUBLISHING OF BOOKS, MAGAZINES, NEWSPAPER, SOFTWARE, TEXT AND GRAPHIC WORKS OF OTHERS CD-ROM, DVD AND ONLINE; ENTERTAINMENT IN THE NATURE OF COMPETITIONS IN THE FIELD OF ATHLETICS (U.S. CLS. 100, 101 AND 107).

**CLASS 42—SCIENTIFIC AND COMPUTER SERVICES**

FOR DESIGN FOR OTHERS IN THE FIELD OF SCIENTIFIC AND TECHNICAL DESIGN OF CLOTHING, FABRICS, MACHINES, ILLUSTRATIONS AND GRAPHICS; SCIENCE AND TECHNOLOGY SERVICES, NAMELY, SCIENTIFIC RESEARCH; SCIENTIFIC RESEARCH AND DEVELOPMENT; INDUSTRIAL RESEARCH AND ANALYSIS IN THE FIELD OF SCIENCE AND CHEMISTRY; DESIGN AND DEVELOPMENT OF COMPUTERS AND PROGRAMS FOR COMPUTERS (U.S. CLS. 100 AND 101).

SIMON TENG, EXAMINING ATTORNEY

**CLASS 9—ELECTRICAL AND SCIENTIFIC APPARATUS**

FOR SCIENTIFIC, NAUTICAL, SURVEYING, PHOTOGRAPHIC, CINEMATOGRAPHIC, OPTICAL, WEIGHING, MEASURING, SIGNALING, CHECKING, LIFE-SAVING AND TEACHING APPARATUS AND INSTRUMENTS, NAMELY, SUNGLASSES, EYE GLASSES CASES, EYE GLASSES CORDS, EYE GLASSES CHAINS, EYEGLASSES FRAMES, EYEGLASSES LENSES, EYEWEAR, CAMERAS; APPARATUS FOR RECORDING, TRANSMISSION OR REPRODUCTION OF SOUND OR IMAGES, NAMELY, CAR NAVIGATION COMPUTERS, CAR TELEVISIONS, CAR VIDEO RECORDERS, CAR BROADCASTING TUNERS, CD PLAYERS, CELL PHONES, CELLULAR PHONE ACCESSORY CHARMS, CELL PHONE COVERS, PERSONAL COMPUTERS, PORTABLE DVD PLAYERS, PORTABLE MEDIA PLAYERS, PORTABLE LISTENING DEVICES, NAMELY, MP3 PLAYERS, VIDEO CAMERAS, TELEVISIONS, VIDEO MONITORS, TELEVISION SETS, LAPTOP COMPUTERS, LAPTOP CARRYING CASES; BLANK MAGNETIC DATA CARRIERS, BLANK OPTICAL RECORDING DISCS; AUTOMATIC VENDING MACHINES AND MECHANISMS FOR COIN OPERATED APPARATUS; CALCULATING MACHINES, DATA PROCESSORS; COMPUTERS (U.S. CLS. 21, 23, 26, 36 AND 38).

**CLASS 12—VEHICLES**

FOR ALL TERRAIN VEHICLES; AUTOMOBILES; CARS; LAND VEHICLES; RACING CARS (U.S. CLS. 19, 21, 23, 31, 35 AND 44).

**CLASS 14—JEWELRY**

FOR PRECIOUS METALS AND THEIR ALLOYS; GOODS IN PRECIOUS METALS OR COATED THEREWITH, NAMELY, ANKLE BRACELETS, BANGLE BRACELETS, BRACELETS, CHOKERS, EARRINGS, CUFFLINKS, CLOCKS, FIGURES OF PRECIOUS METAL, KEY CHAINS, KEY HOLDERS, KEY RINGS, MEDALLIONS, MEDALS, ORNAMENTAL PINS, PENDANTS, RINGS, COMMEMORATIVE COINS, COLLECTIBLE COINS, STATUETTES OF PRECIOUS METALS, STATUES OF PRECIOUS METALS, BOXES OF PRECIOUS METALS; JEWELRY, PRECIOUS STONES; HOROLOGICAL AND CHRONOMETRIC INSTRUMENTS; WATCHES AND CLOCKS (U.S. CLS. 2, 27, 28 AND 50).

**CLASS 16—PAPER GOODS AND PRINTED MATTER**

FOR PAPER CARDBOARD AND GOODS MADE FROM THESE MATERIALS, NAMELY, AGENDAS, ALBUMS FOR STICKERS, AUTOGRAPH BOOKS, BLANK NOTE CARDS, BOOK MARKERS, FILE FOLDERS, MEMO BLOCK, LOOSE LEAF PAPERS, LOOSE LEAF PADS, MEMORANDUM BOARDS, MEMORANDUM BOOKS, NOTE BOOKS, NOTE CARDS, NOTE PAPERS, NOTEBOOKS, NOTEPADS, NOTE BOARDS, PAPER STATIONERY, PERSONAL ORGANIZERS, POCKET MEMORANDUM BOOK, SCRAP BOOKS, STICKERS; IRON ON OR PLASTIC TRANSFERS; PRINTED MATTERS, NAMELY, CALENDARS AND DIARIES, CORRESPONDENCE CARDS, DAILY NEWSPAPER, DAY PLANNERS, DESK CALENDARS, DESKTOP ORGANIZERS, POST CARDS, PRINTED PERIODICALS IN THE FIELD OF VEHICLES, CARS AND AUTOMOBILES; PHOTOGRAPHS; STATIONERY; ADHESIVE FOR STATIONERY OR HOUSEHOLD PURPOSES; TYPEWRITERS AND OFFICE REQUISITES, NAMELY, DESK SETS, PENCILS, PENS, PAPER CLIPS, PAPER CLIP HOLDERS, AUTOMATIC PENCILS, BALL PENS, BALL POINT PENS, COLORED PENCILS, COLORED PENS, CRAYONS, GEL ROLLER PENS, HIGHLIGHTER PENS, MARKERS, ERASERS, PEN AND PENCIL CASES AND BOXES, PEN CLIPS, PEN INK REFILLS, PEN CARTRIDGES, RETRACTABLE PENCILS, ROLLER BALL PENS; PRINTERS' TYPE; PRINTING BLOCKS (U.S. CLS. 2, 5, 22, 23, 29, 37, 38 AND 50).

SN 79-058,975, HORACIO PAGANI S.P.A., I-41018 SAN CESARIO SUL PANARO (MO), ITALY, FILED 7-7-2008.

**PAGANI**

PRIORITY DATE OF 5-30-2008 IS CLAIMED.  
OWNER OF INTERNATIONAL REGISTRATION 0977556 DATED 7-7-2008, EXPIRES 7-7-2018.

THE MARK CONSISTS OF THE WORDING "PAGANI" WRITTEN IN FANCY CHARACTERS PLACED INSIDE A SUBSTANTIALLY ELLIPTICAL SHAPED LABEL.

**CLASS 18—LEATHER GOODS**

FOR LEATHER AND IMITATION OF LEATHER, AND GOOD MADE OF THESE MATERIALS, NAMELY, ALL PURPOSE SPORT BAGS, ALL-PURPOSE ATHLETIC BAGS, ALL-PURPOSE CARRYING BAGS, ATTACHE CASES, BACKPACKS, BAGS FOR SPORTS, BANKNOTE HOLDERS, BEACH BAGS, BELT BAGS, BILLFOLDS, BOOK BAGS, CARD WALLETS, CARRYALLS, CARRYING CASES, CARRYING CASES FOR DOCUMENTS, CARRY-ALL BAGS, CARRY-ON BAGS, COIN PURSES, COSMETIC BAGS SOLD EMPTY, CREDIT CARD CASES, DOCUMENT CASES, EVENING HANDBAGS, FASHION HANDBAGS, FLIGHT BAGS, GYM BAGS, HANDBAGS, HOLDALLS, HUNTING BAGS, KEY CHAINS, KEY BAGS, KEY CASES, KEY WALLETS; ANIMAL SKINS; ANIMAL HIDES; TRUNKS AND TRAVELING BAGS; UMBRELLAS, PARASOLS AND WALKING STICKS; WHIPS, HARNESSES AND SADDLERY (U.S. CLS. 1, 2, 3, 22 AND 41).

**CLASS 20—FURNITURE AND ARTICLES NOT OTHERWISE CLASSIFIED**

FOR FURNITURE, MIRRORS, OF WOOD, CORK REED, CANE, WICKER, HORN, BONE, IVORY, WHALEBONE, SHELL, AMBER, MOTHER-OF-PEARL, MEERSCHAUM AND SUBSTITUTES FOR ALL THESE MATERIALS, OR OF PLASTIC, NAMELY, BOXES, STATUES, FIGURINES; UMBRELLA STANDS; WALL PLAQUE; ARMCHAIRS; ARMOIRES; BEDROOM FURNITURE; BEDS; BOOK CASES; BOOKSHELVES; CABINETS; CAMPING FURNITURE; CHAIRS; CHAISE LOUNGES; COAT STANDS; COMPUTER FURNITURE; COUCHES; COTS; SOFAS; CRADLES; CREDENZAS; CRIBS; CUPBOARDS; DESKS; DINING ROOM TABLES; DIVANS; DRAWERS; TABLES, FURNITURE; FURNITURE FOR HOUSE, OFFICE AND GARDEN (U.S. CLS. 2, 13, 22, 25, 32 AND 50).

**CLASS 25—CLOTHING**

FOR CLOTHING, NAMELY, BANDANAS, BATHING COSTUMES, BATHING SUITS, BATHING TRUNKS, BEACH COVER-UPS, BEACHWEAR, BELTS, BERMUDA SHORTS, BIKINIS, BLAZERS, BLOUSES, BLOUSONS, BOARD SHORTS, BOAS, BODICES, BODY LINEN, BOLEROS, BOW TIES, BOXER BRIEFS, BOXER SHORTS, BRAS, BRASSIERES, BREECHES, BRIEFS, CAMISETTES, CAMISOLES, CAMP SHIRTS, CARDIGANS, CHEMISES, CHEMISETTES, COATS, CORSELETS, CORSETS, CRAVATS, CUFFS, CULOTTES, DENIM JACKETS, DRESS SHIELDS, DRESS SHIRTS, DRESS SUITS, DRESSES, DRESSING GOWNS, GILETS, GLOVES, GOLF PANTS, SHIRTS AND SKIRTS, GOLF TROUSERS, GOWNS, GREATCOAT, GYM PANTS, GYM SHORTS, GYM SUITS, HEAD SCARVES, HOODED PULLOVERS, HOODED SWEAT SHIRTS, HOODS, HOSIERY, JACKETS, JEANS, JERSEYS, JERKINS, JUMPERS, KNICKERS, LEISURE SUITS, LEGGINGS, LINGERIE, MINISKIRTS, NECKTIES, NEGLIGEEES, NIGHT SHIRTS, NIGHTDRESSES, NIGHTIES, NIGHTWEAR, PYJAMAS, PETTICOATS, PLAY SUITS, POLO SHIRTS, PULLOVERS, RAINWEAR, RIDING COATS, RIDING GLOVES, ROBES, SHAWLS, SHIRTS, SHORTS, SHORTS TROUSERS, SILK SCARVES, SINGLETTS, SKI GLOVES, SKI SUITS, SKI WEAR, SKI MASKS, SKI PANTS, SKI TROUSERS, SKI JACKETS, SKIRTS, SLEEPING GARMENTS, SLIPS, SLIPPERS, SNOW SUITS, SNOW PANTS, SNOW GLOVES, SOCKS, SOCK SUSPENDERS, SPORT COATS, SPORT SHIRTS, SPORTS JACKETS, SPORTS JERSEYS, SPORTS PANTS, SPORTS SHIRTS, STOCKINGS, SUITS, SURF WEAR, SWIM TRUNKS, SWIM WEAR, SWIMSUITS, SWIMWEAR, TAILLEURS, TEE SHIRTS, TENNIS DRESSES, TENNIS WEAR, TIES, TIGHTS, TOPS, TRACK JACKETS, TRACK PANTS, TRACK SUITS, TRAINING SUITS, TRUNKS, TROUSERS, TUXEDOS, TWIN SETS, UNDER GARMENTS, UNDERCLOTHES, UNDERSHIRTS, UNDERPANTS, UNDERWEAR, UNDERSKIRTS, WATERPROOF JACKETS AND PANTS; SWEATERS, JUMPSUITS, BODY-SUITS, SWEAT SHORTS, T-SHIRTS, VESTS, WAISTCOATS, PANTIES, OVERCOATS, ANORAKS, RAINCOATS, SHORT PETTICOATS, PETTI-PANTS, NIGHT-GOWNS, TANKINIS, BATH-ROBES, PAREOS, CAFTANS, KIMONOS, GARTER BELTS, WRAPS, FOULARD, SCARVES, STOLEES; FOOTWEAR, BEACH FOOTWEAR, BEACH

SHOES; HEADGEAR, NAMELY, BATHING CAPS, BERETS, BONNETS; BOOTIES, BOOTS, CAPELETS, CAPS, SHOES, DANCE SHOES, DECK-SHOES, GOLF CAPS, GOLF SHOES, GYMNASTIC SHOES, HATS, HORSE-RIDING BOOTS, LEATHER SHOES, LEATHER HEADWEAR, LEISURE SHOES, MOCCASINS, RAIN HATS, RUBBER SHOES, RUNNING SHOES, SABOT, SANDALS, SHOWER CAPS, SKI BOOTS, SKIING SHOES, SMALL HATS, SNEAKERS, SNOW BOOTS, SNOWBOARD BOOTS, SWIM CAPS, TENNIS SHOES, TRACK AND FIELD SHOES, TRAINING SHOES (U.S. CLS. 22 AND 39).

**CLASS 28—TOYS AND SPORTING GOODS**

FOR GAMES, NAMELY, CARD GAMES, BOARD GAMES, ELECTRONIC DART GAMES, PLAYING CARDS, CONSTRUCTION TOYS, MODEL CARS, TOY MODEL CARS, MODEL TOY STEAM ENGINES, MODEL TOYS STEAM OPERATED ENGINES, MODEL PLASTIC TOYS FIGURINES, MODEL TOY FIGURES, TOY VEHICLES AND ACCESSORIES THEREFOR, TOY VEHICLES WITH TRANSFORMING PARTS; SPORTING ARTICLES, NAMELY, GOLF CLUBS, BAGS SPECIALLY ADAPTED FOR SPORTS EQUIPMENT, GOLF BAGS, GOLF IRONS, GOLF GLOVES, GOLF PUTTERS, GOLF PUTTERS COVERS, GOLF TEES, GOLF BALLS, TENNIS RACKETS; GYMNASTIC APPARATUS (U.S. CLS. 22, 23, 38 AND 50).

FRED CARL, EXAMINING ATTORNEY

SN 79-061,487. BOOKRIX GMBH & CO. KG, FED REP GERMANY, FILED 8-4-2008.

web your book

THE MARK CONSISTS OF STANDARD CHARACTERS WITHOUT CLAIM TO ANY PARTICULAR FONT, STYLE, SIZE, OR COLOR.

PRIORITY DATE OF 2-11-2008 IS CLAIMED.  
OWNER OF INTERNATIONAL REGISTRATION 0983483  
DATED 8-4-2008, EXPIRES 8-4-2018.  
OWNER OF U.S. REG. NO. 3,705,499.

**CLASS 38—COMMUNICATION**

FOR TELECOMMUNICATIONS SERVICES, NAMELY, PROVIDING ACCESS TO MULTI-USER INTERNET PLATFORMS AND PORTALS; PROVIDING MULTIPLE USER ACCESS TO A GLOBAL COMPUTER INFORMATION NETWORK; COMPUTER AIDED TRANSMISSION OF MESSAGES AND IMAGES; PROVIDING TELECOMMUNICATION CHANNELS FOR TELESOPPING SERVICES (U.S. CLS. 100, 101 AND 104).

**CLASS 41—EDUCATION AND ENTERTAINMENT**

FOR PUBLICATION OF PERIODICALS AND BOOKS IN ELECTRONIC FORM; PUBLICATION OF ELECTRONIC BOOKS AND JOURNALS ON-LINE; PUBLICATION OF PRINTED MATTER, NAMELY, MAGAZINES, BROCHURES, NEWSPAPERS, COMIC BOOKS, MANGAS, CD-BOOKLETS, DVD-BOOKLETS, SCIENTIFIC PAPERS, ALBUMS FOR STICKERS OR STAMPS, EVENT ALBUMS, PHOTO ALBUMS, GREETING CARDS, WEDDING CARDS, NAME CARDS, MENU CARDS, CATALOGS; PROVIDING A WEBSITE FEATURING INFORMATION CONCERNING WRITING, EDITING AND READING TECHNIQUES, CONCERNING PUBLICATION OF LITERATURE, AND CONCERNING TRAINING IN THE FIELDS OF COMMUNICATION TECHNOLOGY AND COMPUTERS; PUBLICATION OF BOOKS; PROVIDING NON-DOWNLOADABLE ON-LINE PUBLICATIONS IN THE NATURE OF SCIENTIFIC PAPERS ON BIOLOGY, BOTANY, HEALTH, CHEMISTRY, PHYSICS, GEOLOGY; PROVIDING NON-DOWNLOADABLE ON-LINE PUBLICATIONS IN THE NATURE OF MAGAZINES, BOOKS, AUDIO BOOKS, VIDEOS, BROCHURES, NEWSPAPERS, COMIC BOOKS, MANGAS, BOOKLETS FOR CD AND DVDS, IN THE FIELDS OF ADVENTURE, EDUCATION, BIOGRAPHY, BOTANY, BUSINESS, COMEDY, EROTICISM, ESOTERICISM, FAMILY, FANFICTION, FANTASY, FICTION, HOBBIES, HISTORY, HEALTH, HORROR, HUMOR, YOUNG PEOPLE'S LITERATURE, CHILDREN'S LITERATURE, COOKING, THRILLERS, DETECTIVE STORIES, ART, LOVE STORIES, MEMOIRS, FASHION, PHILOSOPHY, POETRY, POLITICS, RELIGION, SATIRE, SCIENCE FICTION, LYRICISM, SPORTS, TECHNOLOGY, ANIMALS, PSYCHOLOGY, GEOGRAPHY, SCIENCE; PROVIDING NON-DOWNLOADABLE ON-LINE PUBLICATIONS IN THE NATURE OF GUIDEBOOKS FOR TRAVEL, SPORTS, LEISURE TIME, HOMEWORK, TOOLS, HOME IMPROVEMENT; ELECTRONIC DESKTOP PUBLISHING FOR OTHERS; SERVICES OF A PUBLISHING COMPANY, NAMELY, PROOF READING OF MANUSCRIPTS FOR OTHERS, EDITING OF WRITTEN TEXTS FOR OTHERS; PUBLICATION OF TEXTS, OTHER THAN PUBLICITY TEXTS; LAYOUT SERVICES, OTHER THAN FOR ADVERTISING PURPOSES; SCRIPTWRITING SERVICES; WRITING OF TEXTS, OTHER THAN PUBLICITY TEXTS; EDUCATION SERVICES, NAMELY, PROVIDING CLASSES, SEMINARS, WORKSHOPS IN THE FIELD OF WRITING, EDITING, READING, PUBLISHING, COMMUNICATION, COMPUTERS, LITERATURE; EDUCATION SERVICES, NAMELY, PROVIDING ONLINE CLASSES, WORKSHOPS, SEMINARS, TUTORING AND MENTORING, VIA COMPUTER DATABASE OR THE INTERNET, IN THE FIELD OF WRITING, READING, PUBLISHING AND LITERATURE; PROVIDING TRAINING IN THE FIELD OF COMMUNICATION TECHNOLOGY AND COMPUTERS; ENTERTAINMENT IN THE NATURE OF CONDUCTING READINGS, CONVENTIONS, FESTIVALS, PARTIES FOR MEMBERS OF CLUBS IN THE FIELD OF MULTIMEDIA TECHNOLOGY AND LITERATURE (U.S. CLS. 100, 101 AND 107).

**CLASS 42—SCIENTIFIC AND COMPUTER SERVICES**

FOR CONVERSION OF DATA OR DOCUMENTS FROM PHYSICAL TO ELECTRONIC MEDIA; CONVERSION OF PRINTED CONTENT IN PHYSICAL FORM, NAMELY, OF BOOKS, MAGAZINES, BROCHURES, NEWSPAPERS, COMIC BOOKS, MANGAS, BOOKLETS FOR CDS AND DVDS, SCIENTIFIC PAPERS, PHOTOGRAPHS, INVITATIONAL CARDS, GREETING CARDS, WEDDING CARDS, NAME CARDS, MENU CARDS, CATALOGS, TO ELECTRONIC FORM FOR USE IN E-READERS (U.S. CLS. 100 AND 101).

JERI J. FICKES, EXAMINING ATTORNEY

SN 79-065,237. SNAP-ON INCORPORATED, KENOSHA, WI. FILED 11-21-2008.

# Sun Test Systems

THE MARK CONSISTS OF STANDARD CHARACTERS WITHOUT CLAIM TO ANY PARTICULAR FONT, STYLE, SIZE, OR COLOR.

OWNER OF INTERNATIONAL REGISTRATION 0823220A DATED 2-27-2004, EXPIRES 2-27-2014.

NO CLAIM IS MADE TO THE EXCLUSIVE RIGHT TO USE "TEST SYSTEMS", APART FROM THE MARK AS SHOWN.

**CLASS 9—ELECTRICAL AND SCIENTIFIC APPARATUS**

FOR MECHANICAL, ELECTRICAL AND ELECTRONIC APPARATUS FOR TESTING IN THE NATURE OF ROLLING TEST BENCHES FOR THE TESTING OF AXLES, WHEELS, SUSPENSIONS FOR CARS, LORRIES, BUSES, LAND VEHICLES AND AIRCRAFT; MECHANICAL, ELECTRICAL AND ELECTRONIC APPARATUS FOR TESTING IN THE NATURE OF BRAKE TEST BENCHES FOR THE TESTING OF BRAKES FOR CARS, LORRIES, BUSES, LAND VEHICLES AND AIRCRAFT; MECHANICAL, ELECTRICAL AND ELECTRONIC APPARATUS FOR THE AIRCRAFT INDUSTRY FOR THE TESTING OF HYDRAULIC SYSTEMS (U.S. CLS. 21, 23, 26, 36 AND 38).

**CLASS 37—CONSTRUCTION AND REPAIR**

FOR INSTALLATION AND REPAIR OF TEST APPARATUS FOR CARS, LORRIES, BUSES, LAND VEHICLES AND AIRCRAFT (U.S. CLS. 100, 103 AND 106).

**CLASS 42—SCIENTIFIC AND COMPUTER SERVICES**

FOR SCIENTIFIC AND TECHNOLOGICAL SERVICES, NAMELY, RESEARCH AND DESIGN IN THE FIELD OF TEST APPARATUS FOR CARS, LORRIES, BUSES, LAND VEHICLES AND AIRCRAFT; INDUSTRIAL ENGINEERING ANALYSIS AND ENGINEERING RESEARCH SERVICES IN THE FIELD OF TEST APPARATUS FOR CARS, LORRIES, BUSES LAND VEHICLES AND AIRCRAFT; DESIGN AND DEVELOPMENT OF COMPUTER HARDWARE AND SOFTWARE IN THE FIELD OF TEST APPARATUS FOR CARS, LORRIES, BUSES, LAND VEHICLES AND AIRCRAFT (U.S. CLS. 100 AND 101).

STEVEN R. FINE, EXAMINING ATTORNEY

SN 79-066,679. FORDAYS CO., LTD., JAPAN, FILED 10-21-2008.



OWNER OF INTERNATIONAL REGISTRATION 0997169 DATED 10-21-2008, EXPIRES 10-21-2018.

THE COLOR(S) RED AND ORANGE IS/ARE CLAIMED AS A FEATURE OF THE MARK.

THE MARK CONSISTS OF A DESIGN CONTAINING INTERMINGLING FLAMES THAT APPEAR IN THE COLORS RED AND ORANGE.

### CLASS 3—COSMETICS AND CLEANING PREPARATIONS

FOR ANTISTATIC PREPARATIONS FOR HOUSEHOLD PURPOSES, NAMELY, ANTI-STATIC SPRAY FOR CLOTHING; DEGREASING PREPARATIONS FOR HOUSEHOLD PURPOSES IN THE FIELD OF LAUNDRY; RUST REMOVING PREPARATIONS; STAIN REMOVING PREPARATIONS IN THE NATURE OF BENZENE; FABRIC SOFTENERS FOR LAUNDRY USE; LAUNDRY BLEACH; ADHESIVES FOR AFFIXING FALSE HAIR; ADHESIVES FOR AFFIXING FALSE EYELASHES; LAUNDRY STARCH; SEAWEED GELATINE FOR LAUNDRY USE (FUNORI); PAINT STRIPPING PREPARATIONS; SHOE AND BOOT CREAM; SHOE BLACK AND SHOE POLISH; POLISHING PREPARATIONS; DENTIFRICES; COSMETICS AND NON-MEDICATED TOILETRIES; SOAPS AND DETERGENTS; PERFUMERY, FRAGRANCES AND INCENSE, NAMELY, FRAGRANCES AND INCENSE OTHER THAN PERFUMES USED AS COSMETICS OR TOILETRIES; ABRASIVE PAPER AND SANDPAPER; ABRASIVE CLOTH; ABRASIVE SAND; ARTIFICIAL PUMICE STONE FOR PERSONAL USE; POLISHING PAPER, NAMELY, CLEANING AND POLISHING PAPER; FALSE NAILS; FALSE EYELASHES (U.S. CLS. 1, 4, 6, 50, 51 AND 52).

### CLASS 29—MEATS AND PROCESSED FOODS

FOR PROCESSED FOOD NOT ADAPTED FOR MEDICAL PURPOSES, IN CAPSULATED, GRANULATED, POWDERED OR GRAINED FORM PRIMARILY MADE FROM NUCLEIC ACID OR VITAMINS EXTRACTED FROM SALMON SOFT ROE, BEER YEAST AND/OR BREWING YEAST; CAPSULATED, GRANULATED, POWDERED OR GRAINED PROCESSED MUSHROOMS, NAMELY, PHELLINUS LINTEUS MUSHROOMS (MESHIMAKOBU); EDIBLE OILS AND FATS; MILK PRODUCTS EXCLUDING ICE CREAM, ICE MILK AND FROZEN YOGURT; FRESH, CHILLED OR FROZEN MEAT FOR HUMAN CONSUMPTION; EGGS; FRESH, CHILLED OR FROZEN EDIBLE AQUATIC ANIMALS, NOT LIVE, NAMELY, FISH, SHELLFISH, CRABS, LOBSTERS; FROZEN VEGETABLES; FROZEN FRUITS; PROCESSED MEAT PRODUCTS, NAMELY, HAM, TURKEY, LAMB, VEAL; PROCESSED SEAFOOD, NAMELY, FROZEN PRE-PACKAGED ENTREES CONSISTING PRIMARILY OF SEAFOOD AND PREPARED ENTREES CONSISTING PRIMARILY OF SEAFOOD; PROCESSED VEGETABLES AND FRUITS; FRIED TOFU PIECES (ABURA-AGE); FREEZE-DRIED TOFU PIECES (KOHRI-DOFU); JELLY MADE FROM DEVILS' TONGUE ROOT (KÖNYAKU); SOYA MILK USED AS A MILK SUBSTITUTE; TOFU; FERMENTED SOYBEANS (NATTO); PROCESSED EGGS; BOUILLON FOR USE IN MAKING STEW AND SOUP; DRIED FLAKES OF LIVER FOR SPRINKLING ON RICE IN HOT WATER (OCHAZUKE-NORI); SIDE DISHES IN THE NATURE OF FROZEN PRE-PACKAGED ENTREES MADE OF FERMENTED SOYBEANS (NAME-MONO); PULSES; PROTEIN POWDERS FOR HUMAN CONSUMPTION FOR USE AS A FOOD ADDITIVE (U.S. CL. 46).

### CLASS 30—STAPLE FOODS

FOR STARCH-BASED BINDING AGENTS FOR ICE CREAM; MEAT TENDERIZERS FOR HOUSEHOLD PURPOSES; PREPARATIONS FOR STIFFENING WHIPPED CREAM, NAMELY, CARBOHYDRATES AND SACCHARIDES IN POWDERED FORM; AROMATIC PREPARATIONS OTHER THAN ESSENTIAL OILS FOR FOOD, NAMELY, FOOD FLAVORINGS; TEA; COFFEE AND COCOA; ICE; CONFECTIONERY, NAMELY, CAKES AND PASTRIES; BREAD AND BUNS; SEASONINGS; SPICES; ICE CREAM MIXES; SHERBET MIXES; UNROASTED COFFEE AND UNPROCESSED COFFEE; ALMOND PASTE; CHINESE STUFFED DUMPLINGS, NAMELY, COOKED GYOZA; SANDWICHES; CHINESE STEAMED DUMPLINGS, NAMELY, COOKED SHUMAI; SUSHI; FRIED BALLS OF BATTER MIXED WITH

SMALL PIECES OF OCTOPUS (TAKOYAKI); STEAMED BUNS STUFFED WITH MINCED MEAT (NIKU-MANJU); HAMBURGER SANDWICHES; PIZZAS; PACKAGED MEAL KITS CONSISTING PRIMARILY OF RICE USED IN BOXED LUNCHES; HOT DOG SANDWICHES; MEAT PIES; RAVIOLI; YEAST POWDER; FERMENTED RICE FOR FOOD (KOJI); YEAST; BAKING POWDER; INSTANT CONFECTIONERY MIXES, NAMELY, BREAD MIXES, MUFFIN MIXES AND CAKE MIXES; SEASONINGS, NAMELY, SAKE LEES; HUSKED RICE; HUSKED OATS; HUSKED BARLEY; FLOUR FOR FOOD; GLUTEN FOR FOOD; SEASONED POWDER FOR SPRINKLING ON RICE (FURI-KAKE); CURRY MIXES (U.S. CL. 46).

RONALD DELGIZZI, EXAMINING ATTORNEY

SN 79-068,256. NADER ANGHA, 41239 MÖNCHENGLADBACH, FED REP GERMANY, FILED 3-3-2009.

## SUFI ASSOCIATION

THE MARK CONSISTS OF STANDARD CHARACTERS WITHOUT CLAIM TO ANY PARTICULAR FONT, STYLE, SIZE, OR COLOR.

OWNER OF INTERNATIONAL REGISTRATION 0861392 DATED 3-31-2005, EXPIRES 3-31-2015.

NO CLAIM IS MADE TO THE EXCLUSIVE RIGHT TO USE "ASSOCIATION", APART FROM THE MARK AS SHOWN.

SEC. 2(F) AS TO "SUFI".

### CLASS 16—PAPER GOODS AND PRINTED MATTER

FOR PRINTED PUBLICATIONS, NAMELY, PRINTED INSTRUCTIONAL, EDUCATIONAL AND TEACHING MATERIALS IN THE FIELDS OF SUFISM, ISLAM AND RELIGION; PAPERBACKS, SMALL BOOKS, BOOKS, AND INSTRUCTION MANUALS ALL IN THE FIELDS OF SUFISM AND RELIGION (U.S. CLS. 2, 5, 22, 23, 29, 37, 38 AND 50).

### CLASS 41—EDUCATION AND ENTERTAINMENT

FOR EDUCATION IN THE NATURE OF CONDUCTING PROGRAMS, COURSES, CLASSES, INSTRUCTION, SEMINARS, CONFERENCES, LECTURES, EXHIBITS, WORKSHOPS AND RETREATS IN THE FIELDS OF SUFISM AND RELIGION; ARRANGING AND CONDUCTING OF EDUCATIONAL COURSES, CLASSES, INSTRUCTION, SEMINARS, LECTURES AND WORKSHOPS IN THE FIELDS OF SUFISM AND RELIGION; EDUCATIONAL SERVICES IN THE NATURE OF CONDUCTING PROGRAMS, COURSES, CLASSES, INSTRUCTION, SEMINARS, CONFERENCES, LECTURES, EXHIBITS, WORKSHOPS AND RETREATS RELATING TO RELIGIOUS DEVELOPMENT CONCERNING SUFISM, EDUCATIONAL SERVICES IN THE NATURE OF PROGRAMS, COURSES, CLASSES, INSTRUCTION, SEMINARS, CONFERENCES, LECTURES, EXHIBITS, WORKSHOPS AND RETREATS RELATING TO SPIRITUAL AND PERSONAL DEVELOPMENT (U.S. CLS. 100, 101 AND 107).

### CLASS 45—PERSONAL AND LEGAL SERVICES

FOR ORGANIZATION OF RELIGIOUS MEETINGS, PROVIDING INFORMATION IN THE FIELDS OF SUFISM AND RELIGION ON THE INTERNET (U.S. CLS. 100 AND 101).

WILLIAM ROSSMAN, EXAMINING ATTORNEY

SN 79-068.871. PROFIBUS NUTZERORGANISATION E.V.,  
FED REP GERMANY, FILED 4-6-2009.

SN 79-069.346. VALENTINO FASHION GROUP S.P.A., I-  
20121 MILANO, ITALY, FILED 12-2-2008.



OWNER OF INTERNATIONAL REGISTRATION 1002865  
DATED 4-6-2009, EXPIRES 4-6-2019.

OWNER OF U.S. REG. NO. 3,114,423.

NO CLAIM IS MADE TO THE EXCLUSIVE RIGHT TO  
USE "INDUSTRIAL ETHERNET" AND "NET", APART  
FROM THE MARK AS SHOWN.

THE COLOR(S) GREEN AND WHITE IS/ARE CLAIMED  
AS A FEATURE OF THE MARK.

THE MARK CONSISTS OF A GREEN LINE WITH FIVE  
GREEN SQUARES WITH ROUNDED CORNERS IN A LINE  
ABOVE THE GREEN LINE AND FIVE GREEN SQUARES  
WITH ROUNDED CORNERS APPEARING BELOW THE  
GREEN LINE. EACH SQUARE IS CONNECTED TO THE  
CENTER GREEN LINE BY A SHORT GREEN LINE. THE  
WORDS "INDUSTRIAL ETHERNET" APPEAR IN WHITE  
LETTERS IN THE MIDDLE OF THE CENTER GREEN LINE.  
THE WORD "PROFI" APPEAR IN THE SQUARES ABOVE  
THE LINE IN WHITE, AND THE LETTERS "NET" APPEAR  
IN THE SQUARES BELOW THE LINE, ALSO IN WHITE.

#### **CLASS 9—ELECTRICAL AND SCIENTIFIC APPARATUS**

FOR ELECTROTECHNICAL AND ELECTRONIC AP-  
PLIANCES, DEVICES AND INSTRUMENTS, NAMELY,  
COMPUTER HARDWARE, ELECTRICAL PROGRAM-  
MERS AND ELECTRICAL CONTROLLERS FOR INDUS-  
TRIAL AUTOMATION AND CONTROL OF  
INDUSTRIAL MACHINES, PROGRAMMING CON-  
TROLLERS, ELECTRICAL CONTROLLERS, DISTRIBUTED  
INPUT OUTPUT DEVICES FOR COMPUTER  
HARDWARE AND PROGRAMMING CONTROLLERS,  
ELECTRICAL CONTROLLERS FOR OPERATING  
AUTOMATION MACHINERY, COMPUTER MONITORS  
AND COMPUTER HARDWARE FOR CONTROLLING  
AND MONITORING AUTOMATION PROCESSES, ELEC-  
TRICAL SENSORS, PROXIMITY SENSORS, RADIO  
FREQUENCY IDENTIFICATION SENSORS, OPTICAL  
SENSORS, SENSORS FOR AUTOMATION PROCESSES  
TO RECORD, COUNT, MEASURE, POSITION, TRACK  
AND INSPECT MATERIALS AND TO CONTROL AND  
OPTIMIZE MATERIAL FLOW AND LOGISTICS, ELEC-  
TRICAL AND COMPUTER CABLES, ELECTRICAL AND  
COMPUTER CONNECTORS; OPEN AND CLOSED-LOOP  
CONTROL AND SWITCHING DEVICES; ELECTRICAL  
DEVICES FOR INPUT, PROCESSING, TRANSMISSION,  
STORAGE AND OUTPUT OF DATA; REPLACEMENT  
PARTS OF THE MENTIONED ABOVE APPLIANCES,  
DEVICES AND INSTRUMENTS; DATA PROCESSING  
PROGRAMS (U.S. CLS. 21, 23, 26, 36 AND 38).

#### **CLASS 16—PAPER GOODS AND PRINTED MATTER**

FOR PRINTED MATERIALS, NAMELY, BOOKS,  
MANUALS, AND PAMPHLETS, ALL PERTAINING TO  
INFORMATION AND DATA SYSTEMS TECHNOLOGY  
(U.S. CLS. 2, 5, 22, 23, 29, 37, 38 AND 50).

#### **CLASS 42—SCIENTIFIC AND COMPUTER SERVICES**

FOR DEVELOPMENT, GENERATION AND RENTING  
OF DATA PROCESSING PROGRAMS (U.S. CLS. 100  
AND 101).

DAVID HOFFMAN, EXAMINING ATTORNEY



PRIORITY DATE OF 6-4-2008 IS CLAIMED.

OWNER OF INTERNATIONAL REGISTRATION 1003965  
DATED 12-2-2008, EXPIRES 12-2-2018.

THE MARK CONSISTS OF THE STYLIZED WORDING  
"MCS".

#### **CLASS 3—COSMETICS AND CLEANING PRE- PARATIONS**

FOR COSMETICS, INCLUDING NIGHT AND DAY  
CREAMS; CLEANING PREPARATIONS FOR CARE OF  
THE FACE AND BODY, BATH FOAM; SHAVING FOAM,  
AFTERSHAVES; FOUNDATION MAKEUP; NAIL POL-  
ISH; DEODORANTS FOR PERSONAL USE FOR MEN  
AND WOMEN; HAND AND BODY SOAPS; HAIR  
SHAMPOOS AND RINSES; HAIR SPRAY; TOOTHPASTE;  
FRAGRANCES, NAMELY, PERFUME, TOILET WATER  
AND ESSENTIAL OILS FOR PERSONAL USE FOR MEN  
AND WOMEN (U.S. CLS. 1, 4, 6, 50, 51 AND 52).

#### **CLASS 9—ELECTRICAL AND SCIENTIFIC APPARATUS**

FOR OPTICAL INSTRUMENTS, APPARATUS AND  
EQUIPMENT, NAMELY, OPTICAL TRANSMITTERS;  
EYEGLASSES, SUNGLASSES; SPECTACLES; SPECTA-  
CLE FRAMES; MONOCLES; LORGNETTES; STRUC-  
TURAL PARTS AND CASES FOR ALL THE  
AFORESAID GOODS (U.S. CLS. 21, 23, 26, 36 AND 38).

#### **CLASS 14—JEWELRY**

FOR ARTICLES MADE OF PRECIOUS METALS AND  
ALLOYS OF PRECIOUS METALS WITH OR WITHOUT  
PRECIOUS STONES, NAMELY, RINGS, NECKLACES,  
BRACELETS, BROOCHES, EARRINGS, TIE CLIPS, CUF-  
FLINKS, DIAMONDS, JEWEL CASES, WATCHES,  
CLOCKS, CHRONOMETERS, WATCH CASES; COS-  
TUME JEWELRY; KEY CHAINS; STRUCTURAL PARTS  
AND FITTINGS FOR ALL THE AFORESAID GOODS  
(U.S. CLS. 2, 27, 28 AND 50).

#### **CLASS 16—PAPER GOODS AND PRINTED MATTER**

FOR STATIONERY ARTICLES, NAMELY, PAPER,  
LETTER PAPER, LOOSE-LEAF PAPER, EXERCISE  
BOOKS, ADDRESS BOOKS AND NOTEBOOKS, FLASH  
CARDS, NAMELY, NUMERICAL AND ALPHABETICAL  
INSERTS, ENVELOPES, CARDS, NAMELY, GREETING  
CARDS, NOTE CARDS, BUSINESS CARDS, PLACE  
CARDS, CORRESPONDENCE CARDS, ALBUMS FOR  
EVENTS, COINS, PHOTOGRAPHS, STAMPS, STICKERS,  
WEDDING; FILE BOOKS, NAMELY, ADDRESS BOOKS,  
RECIPE BOOKS, BABY BOOKS, WRITING AND MARK-  
ING INSTRUMENTS, NAMELY, PENS, FELT-TIPPED  
PENS, MARKING PENS, PENCILS AND PENCIL LEADS,  
REFILLS FOR PENS, ERASERS; PRINTED MATTER,  
NAMELY, BOOKS ABOUT FASHION; PERIODICAL  
PUBLICATIONS, NAMELY, MAGAZINES ABOUT  
CLOTHING, BOOKS IN THE FIELD OF FASHION,  
PRINTING TYPE, LEAFLETS ABOUT FASHION AND  
CLOTHING (U.S. CLS. 2, 5, 22, 23, 29, 37, 38 AND 50).

**CLASS 18—LEATHER GOODS**

FOR LEATHER AND IMITATIONS OF LEATHER, HANDBAGS, WALLETS, LUGGAGE, ATTACHÉ CASES, TOTE BAGS, BRIEFCASES, SPORTS BAGS, TRAVELING TRUNKS, CARRY-ON BAGS, SHOULDER BAGS, GARMENT BAGS FOR TRAVELING, KEY CASES, UMBRELLAS, PARASOLS, WALKING STICKS, WHIPS, HARNESSSES, SADDLERY (U.S. CLS. 1, 2, 3, 22 AND 41).

**CLASS 24—FABRICS**

FOR BATH LINEN, BED LINEN; BED BLANKETS, CASHMERE BLANKETS; CURTAINS; UNFITTED FURNITURE COVERS NOT OF PAPER; HANDKERCHIEFS; KITCHEN TOWELS; ALL THE AFOREMENTIONED GOODS NOT FOR MOISTURE CONTROL (U.S. CLS. 42 AND 50).

**CLASS 25—CLOTHING**

FOR CLOTHING FOR MEN, WOMEN AND CHILDREN, NAMELY, BELTS, COATS, RAINCOATS, WAISTCOATS, BLOUSES AND PULLOVERS, JACKETS, TROUSERS, SKIRTS, DRESSES, SUITS, SHIRTS AND CHEMISES, T-SHIRTS, SWEATERS, UNDERWEAR, SOCKS AND STOCKINGS, GLOVES, TIES, SCARVES, HATS AND CAPS, BOOTS, SHOES AND SLIPPERS, NOT SPECIFICALLY DEVOTED TO MOISTURE CONTROL AND/OR NOT MADE FROM FABRIC SPECIFICALLY DEVOTED TO MOISTURE CONTROL (U.S. CLS. 22 AND 39).

TASNEEM HUSSAIN, EXAMINING ATTORNEY

SN 79-074,507. UNIVERSITY COURT; OF THE UNIVERSITY OF ABERDEEN, KINGS COLLEGE; ABERDEEN, UNITED KINGDOM, FILED 9-30-2009.

**DRAM**

THE MARK CONSISTS OF STANDARD CHARACTERS WITHOUT CLAIM TO ANY PARTICULAR FONT, STYLE, SIZE, OR COLOR.

OWNER OF INTERNATIONAL REGISTRATION 1017618 DATED 9-30-2009, EXPIRES 9-30-2019.

**CLASS 1—CHEMICALS**

FOR INDUSTRIAL CHEMICALS FOR TREATING CONTAMINATED WATER AND SOIL; DRAFF FOR CHEMICALLY REMOVING POLLUTANTS FROM CONTAMINATED WATER AND SOIL AS A RESULT OF ITS CHEMICAL ABSORPTION PROPERTIES AND BY MINERALIZING ORGANIC MOLECULES AND RENDERING THEM INTO CARBON DIOXIDE AND WATER (U.S. CLS. 1, 5, 6, 10, 26 AND 46).

**CLASS 40—MATERIAL TREATMENT**

FOR TREATMENT OF CONTAMINATED WATER AND SOIL; CONSULTANCY AND ADVISORY SERVICES IN THE FIELD OF TREATMENT OF CONTAMINATED WATER AND SOIL (U.S. CLS. 100, 103 AND 106).  
LAURA HAMMEL, EXAMINING ATTORNEY

SN 79-074,780. SMS GMBH, FED REP GERMANY, FILED 9-29-2009.



PRIORITY DATE OF 4-7-2009 IS CLAIMED.

OWNER OF INTERNATIONAL REGISTRATION 1018392 DATED 9-29-2009, EXPIRES 9-29-2019.

THE COLOR(S) BLACK, RED AND BLUE IS/ARE CLAIMED AS A FEATURE OF THE MARK.

THE MARK CONSISTS OF A BLACK SOLID CIRCLE WITHIN A LARGER, INCOMPLETE RED CIRCLE, WHICH IS IN TURN WITHIN A LARGER, INCOMPLETE BLUE CIRCLE, WHICH IS IN TURN WITHIN A LARGER, INCOMPLETE RED CIRCLE. THE COLOR WHITE REPRESENTS BACKGROUND AND TRANSPARENT AREAS AND IS NOT PART OF THE MARK.

**CLASS 6—METAL GOODS**

FOR COMMON METALS AND THEIR ALLOYS, NAMELY, CAST IRON, STEEL, COPPER INGOTS, ALUMINUM INGOTS, IRON ALLOYS, STEEL ALLOYS, COPPER ALLOYS AND ALUMINUM ALLOYS; METAL BUILDING MATERIALS, NAMELY, STRUCTURAL STEELS, SHEET PILING, SECTIONAL BEAMS AND PIPES MADE OF METAL; NON-ELECTRIC CABLES AND WIRES OF COMMON METAL; PIPES AND TUBES OF METAL (U.S. CLS. 2, 12, 13, 14, 23, 25 AND 50).

**CLASS 7—MACHINERY**

FOR MACHINES FOR THE TREATMENT, PROCESSING, AND PRODUCTION OF METALS AND PLASTICS, NAMELY, MILLING MACHINES AND GRINDING MACHINES, AND MACHINES UTILIZING ROTATIONAL MOTION FOR HIGH ENERGY SURFACE FINISHING AND MATERIAL TREATMENT, IN PARTICULAR, HEAVY, MEDIUM AND LIGHT SECTION ROLLING MILLS, COLD AND HOT MILLS, STRIP AND WIDE STRIP MILLS, PLATE AND SHEET MILLS, BLOOMING, SLABBING AND BILLET MILLS, UNIVERSAL MILLS, PLANETARY MILLS, MULTI-PURPOSE COLD MILLS, ROD, BAR AND TUBE MILLS, CONTINUOUS MILLS, REVERSING MILLS, PILGRIM MILLS, DETACHING MILLS AND MILLS FOR THE ROLLING OF STEEL, IRON, ALUMINUM AND COPPER OR FOR THE ROLLING OF ALLOYS OF THE SAME, AND STRUCTURAL PARTS FOR THE AFOREMENTIONED ROLLING MILLS; ROLLING MILLS FOR WIRE, STEEL ROLLING MILLS, BLOOM ROLLING MILLS, RAIL ROLLING MILLS, AND SECTION ROLLING MILLS, DRAWING MACHINES, WIRE RING PRESSES, METAL REELING MACHINES; MACHINES FOR MANUFACTURING, PROCESSING AND WORKING SEAMLESS AND WELDED PIPES, NAMELY, PIPE EXPANDING MACHINES, LARGE PIPE MANUFACTURING MACHINES, HOT AND COLD PIPE ROLLING MILLS, PRESSES, IN PARTICULAR, EXTRUSION PRESSES, IMPACT EXTRUSION, COLD EXTRUSION AND BACKFLOW EXTRUSION PRESSES, CABLE SHEATHING PRESSES, STRAIGHTENING AND BENDING PRESSES, PLATE SHAPING PRESSES, DEEP-DRAWING PRESSES, MULTI-STAGE PRESSES, HYDRAULIC METAL POWDER PRESSES, AND STRUCTURAL PARTS THEREFOR; FORGING MACHINES, IN PARTICULAR, OPEN-DIE FORGING MACHINES, AUTOMATIC FORGING HAMMERS, FORGING PRESSES, PIERCING PRESSES AND



COUNTER BLOW HAMMERS, AND STRUCTURAL PARTS FOR THE AFOREMENTIONED FORGING MACHINES; CASTING MACHINES, IN PARTICULAR, CONTINUOUS STEEL SLAB CASTING MACHINES AND MACHINES FOR THE CONTINUOUS CASTING OF METALS, PLASTIC EXTRUSION AND PLASTIC MOLDING MACHINES, AND STRUCTURAL PARTS FOR THE AFOREMENTIONED CASTING MACHINES; ELECTRIC POWER GENERATION MACHINES FOR ROLLING, PRESSING, FORGING AND CASTING INSTALLATIONS; MACHINES FOR THE TREATMENT, PROCESSING, AND PRODUCTION OF METALS AND PLASTICS, NAMELY, ROLLING MILLS AND CONTINUOUS METAL CASTING MACHINES FEATURING COOLING APPARATUS IN THE NATURE OF WATER SPRAYERS AND AIR COOLERS AS INTEGRAL COMPONENTS THEREOF; HYDRAULIC DRIVING MACHINES, NAMELY, TORQUE CONVERTERS NOT FOR LAND VEHICLES; SUPPORTING CHAIN CONVEYORS AND HOISTS, ROLLER TABLES IN THE NATURE OF CONVEYORS, TILTERS IN THE NATURE OF INDUSTRIAL MACHINES FOR POSITIONING METAL AS IT IS BEING CUT, SCALE ELECTRIC WASHING MACHINES FOR INDUSTRIAL PURPOSES, AND CLEANING MACHINES FOR CLEANING ROLLER CONVEYORS, AND ROLLING MACHINES FOR ROLLING METALS; CONVEYORS FOR THE CONVEYING OF ROLLED, PRESSED, FORGED AND CAST ARTICLES TO AND FROM ROLLING, PRESSING, FORGING AND CASTING INSTALLATIONS; ELECTRIC WELDING MACHINES, IN PARTICULAR, PIPE WELDING MACHINES, BUTT-WELDING MACHINES; CUTTING MACHINES FOR CUTTING AND TRIMMING, LONGITUDINALLY OR TRANSVERSELY, ROLLED METAL PIPE, ROLLED PROFILES, INGOTS, AND STRIPS; FLAME CUTTING MACHINES FOR STRIPPING SCALE OFF INGOTS, BLOOMS AND STRIPS; MACHINES FOR FILLING AND EMPTYING BLAST FURNACES; MACHINES FOR TILTING, PIVOTING, AND MOVING CONVERTERS AND LADLES, NAMELY, CRANES AND MECHANICAL AND HYDRAULIC LIFTS FOR MANIPULATING CRUCIBLES FILLED WITH MOLTEN METAL SO THAT THE METALS CAN BE Poured INTO MOLDS OF A CONTINUOUS CASTER; ALL THE AFOREMENTIONED MACHINES FOR THE TREATMENT, PROCESSING, AND PRODUCTION OF METALS AND PLASTICS; MACHINES FOR THE CHEMICAL INDUSTRY, NAMELY, CHEMICAL FIBER DRYING MACHINES, EXTRACTING MACHINES FOR CHEMICAL PROCESSING; MACHINES FOR AGRICULTURE, NAMELY, COMBINES, HARVESTERS, THRESHERS, AND TILTERS; MACHINES FOR MINING, IN PARTICULAR, EXCAVATORS, CUTTERS, EARTH AND BURDEN MOVERS, LOADERS, CUTTERS AND CONVEYORS; MACHINES FOR MINING, NAMELY, MINING SHAFT EXCAVATORS, HOISTS, SKIPS FOR LIFTING LARGE LOADS IN MINING OPERATIONS, WINDLASSES; MACHINES FOR MINING, NAMELY, INCLINED CONVEYORS, WINDING ENGINES IN THE NATURE OF HAULING ENGINES FOR DRIVING THE DRUM OVER WHICH A CABLE EXTENDING ALONG THE LENGTH OF A MINE IS WOUND, BUCKET CONVEYORS, CONVEYOR BELTS, MINE CAR FILLERS, UNLOADING MACHINES, AND WINDING TOWERS FOR CARRYING A DRIVE DRUM FOR MINING CABLES AT THE SURFACE FEATURING HEAD FRAMES AS INTEGRATED COMPONENTS THEREOF; MACHINES FOR MINING, NAMELY, HYDRAULIC AND PNEUMATIC CONVEYORS AND SOLIDS TRANSPORTERS; MACHINES FOR MINING, NAMELY, PIPELINE CONVEYORS; MACHINES FOR MINING, NAMELY, WASTE DISPOSAL COMMUNUTERS, CONVEYORS, LOADERS FOR LOADING CONTAINERS WITH RADIO-ACTIVE WASTE, TRANSPORTERS FOR RADIOACTIVE WASTE CONTAINERS; MACHINES FOR THE TREATMENT, PROCESSING AND PRODUCTION OF METALS AND PLASTICS, NAMELY, METAL COIL HANDLERS, METAL COIL WINDERS, METAL COIL CONVEYORS, METAL COIL PACKAGERS, METAL COIL STACKERS; MACHINES FOR THE TREATMENT, PROCESSING AND PRODUCTION OF METALS AND PLASTICS, NAMELY, CRANES, HOISTS AND CLAMPS BEING STRUCTURAL PARTS THEREOF; MACHINES FOR THE TREATMENT, PROCESSING AND PRODUCTION OF METALS AND PLASTICS, NAMELY, ROLLING MILL ROLL REPLACE- MENT MACHINES; MOTORS AND ENGINES EXCEPT FOR LAND VEHICLES, NAMELY, ELECTRIC MOTORS OR ELECTRIC GEAR MOTORS; MACHINE COUPLING AND TRANSMISSION COMPONENTS NOT FOR LAND

VEHICLES, NAMELY, HYDRAULIC AND MECHANICAL TRANSMISSIONS FOR MACHINERY AND STRUCTURAL PARTS THEREFOR (U.S. CLS. 13, 19, 21, 23, 31, 34 AND 35).

#### **CLASS 9—ELECTRICAL AND SCIENTIFIC APPARATUS**

FOR WEIGHING, MEASURING, SIGNALING, AND CHECKING APPARATUS AND INSTRUMENTS FOR CONDUCTING, SWITCHING, TRANSFORMING, ACCUMULATING, REGULATING OR CONTROLLING ELECTRICITY, NAMELY, STRIP TENSION DYNAMOMETERS, STRIP FLATNESS METERS, THERMOMETERS, SPEEDOMETERS, PRESSURE GAUGES, ANGLE GAUGES, DISTANCE METERS, ROUGHNESS GAUGES, AND ELECTRIC AND ELECTRONIC CONTROLLERS FOR MACHINES IN THE NATURE OF FLATNESS CONTROLLERS, ROUGHNESS CONTROLLERS, PRESSURE CONTROLLERS AND TENSIONING CONTROLLERS FOR INFLUENCING THE PROPERTIES OF ROLLED STEEL; ELECTRONIC CONTROL PANELS FOR ROLLING MILLS, ELECTRICAL AND MAGNETIC DETECTORS FOR MONITORING THE PROPERTIES OF ROLLED STEEL; FREQUENCY METERS; CALCULATING MACHINES; DATA PROCESSORS, AND COMPUTERS FOR USE IN OPERATING AND CONTROLLING OPERATIONS OF METALLURGICAL PLANTS AND ROLLING MILLS; PRERECORDED MAGNETIC DATA CARRIERS FEATURING COMPUTER APPLICATION SOFTWARE FOR CONTROLLING AND REGULATING MACHINES AND MACHINE TOOLS FOR THE METAL INDUSTRY; COMPUTERS FEATURING PROGRAMS FOR CONTROLLING ROLLING MILLS, FURNACE PLANTS, CONTINUOUS CASTING MACHINES; COMPUTER PROGRAMS FOR CONTROLLING AND REGULATING MACHINES FOR THE METALLURGICAL INDUSTRY, MACHINES FOR THE STEEL INDUSTRY, CONTINUOUS CASTING MACHINES, ROLLING MACHINES, FORGING MACHINES, PRESSING MACHINES AND MACHINES FOR PROCESSING SYNTHETIC MATERIALS (U.S. CLS. 21, 23, 26, 36 AND 38).

#### **CLASS 11—ENVIRONMENTAL CONTROL APPARATUS**

FOR APPARATUS FOR HEATING, STEAM GENERATING, COOKING, REFRIGERATING, DRYING, VENTILATING, AND WATER SUPPLY PURPOSES, NAMELY, FURNACES FOR METALLURGICAL PLANTS, STEEL MILLS, CONTINUOUS CASTING PLANTS, AND FORGING AND PRESSING PLANTS; INDUSTRIAL WATER RECIRCULATION COOLING AND HEATING SYSTEMS FOR ROLLING, PRESSING, FORGING AND CASTING INSTALLATIONS, COMPRISING FURNACES, COOLING TOWERS, COOLING FANS, HEAT INSULATION, WATER ROLL COOLERS, STRIP PREHEATERS, SPRAY WATER COOLING SECTIONS SPRAYERS, AND SLAB COOLING WHEELS; OIL AND WATER TREATMENT, COOLING, AND PURIFYING SYSTEMS FOR ROLLING, PRESSING, FORGING AND CASTING INSTALLATIONS IN THE METALLURGICAL AND STEEL MILL INDUSTRIES, COMPRISING SEPARATORS FOR THE CLEANING AND PURIFICATION OF LIQUIDS, WATER SEPARATORS, WATER FILTERS, COOLANT PURIFYING DEVICES, WATER NEUTRALIZATION PLANTS, AND WASHING BRUSHING MACHINES; APPARATUS FOR HEATING, NAMELY, WATER HEATERS FOR INDUSTRIAL PURPOSES, HEAT SINKS FOR USE IN INDUSTRIAL HEATING APPARATUS, ELECTRIC HEATING PANELS USED FOR INDOOR HEATING PURPOSES; ELECTRIC HEATERS AND FURNACES FOR ROLLING STOCK, NAMELY, FOR ROLLING METAL PRODUCTS SUBJECT TO ROLLING IN A ROLLING MILL, AND FOR CONTINUOUS CASTING PLANTS; STEAM GENERATORS; REFRIGERATED MERCHANDISE DISPLAY CASES; AIR COOLING APPARATUS FOR USE IN THE METALLURGICAL AND STEEL MILL INDUSTRIES IN THE NATURE OF DEVICES FOR COOLING THE ENVIRONMENT IN AN INDUSTRIAL SETTING; VENTILATING AND DRYING FANS FOR COMMERCIAL AND INDUSTRIAL USE; VENTILATING LOUVERS; COOLING WATER CIRCUIT INSTALLATIONS, NAMELY, WATER COOLING TOWERS; AIR COOLERS FOR METALLURGICAL PLANTS, STEEL MILLS, CONTINUOUS CASTING PLANTS, ROLLING MILLS, AND FORGING AND

PRESSING PLANTS; SMELTING MACHINES; INDUSTRIAL AIR FILTER MACHINES FOR USE WITH ROLLING, PRESSING, FORGING, AND CASTING INSTALLATIONS (U.S. CLS. 13, 21, 23, 31 AND 34).

#### CLASS 35—ADVERTISING AND BUSINESS

FOR ADVERTISING SERVICES; BUSINESS MANAGEMENT CONSULTANCY; BUSINESS ADMINISTRATION; PROVIDING OFFICE FUNCTIONS (U.S. CLS. 100, 101 AND 102).

#### CLASS 37—CONSTRUCTION AND REPAIR

FOR INSTALLATION AND REPAIR OF INDUSTRIAL AND MACHINERY SYSTEMS, NAMELY, MACHINES FOR THE METALLURGICAL INDUSTRY, MACHINES FOR THE STEEL MILL INDUSTRY, CONTINUOUS CASTING MACHINES, ROLLING MACHINES FOR THE ROLLING OF METALS, FORGING MACHINES, PRESSES FOR METALS, MACHINES FOR THE WORKING AND PROCESSING OF PLASTICS, MACHINE TOOLS, ENGINES AND MOTORS, EXCEPT ENGINES FOR LAND VEHICLES, CLUTCHES AND COUPLINGS AND DEVICES FOR POWER TRANSFER, EXCEPT FOR LAND VEHICLES (U.S. CLS. 100, 103 AND 106).

#### CLASS 40—MATERIAL TREATMENT

FOR TREATMENT OF MATERIALS, NAMELY, METAL TREATING, ROLLING, FORGING, GRINDING, PARTS MOLDING, SWAGING, TEMPERING, CASTING, MILLING, PLANING, COATING, CUTTING, TURNING, SURFACE REFINING BY ABRASION, AND PLATING OF METALS TO THE ORDER AND SPECIFICATION OF OTHERS (U.S. CLS. 100, 103 AND 106).

#### CLASS 42—SCIENTIFIC AND COMPUTER SERVICES

FOR SCIENTIFIC RESEARCH IN THE FIELD OF THE TREATMENT, PROCESSING, AND PRODUCTION OF METALS AND PLASTICS; TECHNOLOGICAL CONSULTING SERVICES IN THE FIELD OF THE TREATMENT, PROCESSING, AND PRODUCTION OF METALS AND PLASTICS; DESIGN AND DEVELOPMENT OF COMPUTERS AND COMPUTER SOFTWARE FOR OTHERS; TECHNICAL CONSULTANCY IN RELATION TO THE OPERATION OF MACHINES FOR THE METALLURGICAL INDUSTRY, MACHINES FOR THE STEEL MILL INDUSTRY, CONTINUOUS CASTING PLANTS, ROLLING MACHINES, FORGING MACHINES, PRESSING MACHINES, TECHNICAL CONSULTANCY FOR THE METALLURGICAL INDUSTRY REGARDING TESTING, ANALYSIS AND EVALUATION OF MACHINERY FOR THE STEEL MILL INDUSTRY, INCLUDING CONTINUOUS CASTING PLANTS, ROLLING MACHINES, FORGING MACHINES, PRESSING MACHINES (U.S. CLS. 100 AND 101).

JAMES MACFARLANE, EXAMINING ATTORNEY

SN 79-075,089. SPANSET INTER AG, CH-8832 WOLLERAU, SWITZERLAND, FILED 6-23-2009.

# Gotcha

THE MARK CONSISTS OF STANDARD CHARACTERS WITHOUT CLAIM TO ANY PARTICULAR FONT, STYLE, SIZE, OR COLOR.

OWNER OF INTERNATIONAL REGISTRATION 1019172 DATED 6-23-2009, EXPIRES 6-23-2019.

#### CLASS 7—MACHINERY

FOR POWER-OPERATED LIFE-SAVING SAFETY MECHANISM, NAMELY, A CONTROLLED DESCENT DEVICE COMPRISED OF SEVERAL DESCENT SLOWING MECHANISMS ALLOWING FOR THE REGULATED DESCENT AT A FIXED AND SAFE SPEED, A HARNESS ATTACHED AT EITHER END OF A STEEL FIBER CABLE, AND AN ASSORTMENT OF ACCESSORIES ATTACHED THERETO, NAMELY, BELTS FOR LIFTS, BELTS FOR SECURING PERSONNEL, CABLES FOR LIFTS, CABLES BEING PARTS OF HOISTING MACHINES, PULLEYS BEING PARTS OF LIFTS, AND PULLEYS BEING PARTS OF HOISTING MACHINES; PARTS OF THE AFOREMENTIONED MACHINES; REPLACEMENT PARTS OF THE AFOREMENTIONED MACHINES (U.S. CLS. 13, 19, 21, 23, 31, 34 AND 35).

#### CLASS 22—CORDAGE AND FIBERS

FOR NON-METALLIC ARTICLES FOR LIFTING, LOWERING, AND SECURING, NAMELY, HOISTING SLINGS, CABLES, LIFTING COLLARS, NAMELY SLINGS, LIFTING HARNESES; REPLACEMENT PARTS OF THESE PRODUCTS (U.S. CLS. 1, 2, 7, 19, 22, 42 AND 50).

DEBRA LEE, EXAMINING ATTORNEY

SN 79-075,134. ETABLISSEMENTS SIMOND, FRANCE, FILED 4-28-2009.

# SIMOND

PRIORITY DATE OF 11-7-2008 IS CLAIMED.  
OWNER OF INTERNATIONAL REGISTRATION 1019308 DATED 4-28-2009, EXPIRES 4-28-2019.  
OWNER OF U.S. REG. NO. 1,442,784.  
SEC. 2(F).

#### CLASS 6—METAL GOODS

FOR COMMON METALS, UNWROUGHT AND SEMI-WROUGHT, AND THEIR ALLOYS FOR THE MANUFACTURE OF MOUNTAINEERING AND CLIMBING ARTICLES; ROLLED AND CAST METAL BARS FOR THE MANUFACTURE OF MOUNTAINEERING AND CLIMBING ARTICLES; CLIMBING IRONS, METAL PITONS, CLIMBING STIRRUPS, METAL HOOKS FOR CARRIERS, MASTS OF METAL, METAL CLIMBING STAKES, METAL KARABINERS, METAL BUCKLES, FASTENERS FOR CRAMPONS; PULLEYS OF METAL OTHER THAN FOR MACHINES, METAL EXPANSION PITONS, PREFABRICATED METAL PLATFORMS, METAL LADDERS, METAL CLIMBING BOARDS, METAL WHEEL CHOCKS (U.S. CLS. 2, 12, 13, 14, 23, 25 AND 50).

#### CLASS 8—HAND TOOLS

FOR HAND-OPERATED HAND TOOLS AND IMPLEMENTS FOR MOUNTAINEERING AND CLIMBING, NAMELY, MOUNTAINEERING PICKS, ICE AXES, PICKAXES, PICKS, SNOW AND CAMPING SHOVELS; ICE KNIVES, HAND-POWERED DRILLS (U.S. CLS. 23, 28 AND 44).

**CLASS 9—ELECTRICAL AND SCIENTIFIC APPARATUS**

FOR OPTICAL APPARATUS AND INSTRUMENTS, NAMELY, BINOCULARS, EYE GLASSES, AND TELESCOPES; SIGNALING APPARATUS AND INSTRUMENTS FOR MOUNTAINEERING AND CLIMBING, NAMELY, GLOBAL POSITIONING SYSTEM (GPS) FOR MOUNTAINEERING AND CLIMBING, EMERGENCY FLARES, AND RESCUE FLARES; LIFE-SAVING RESCUE APPARATUS AND INSTRUMENTS FOR MOUNTAINEERING AND CLIMBING, NAMELY, AVALANCHE PROBES, NAMELY, ELONGATED RODS USED TO MANUALLY PROBE FOR PEOPLE OR OBJECTS COVERED BY AN AVALANCHE; PROTECTION DEVICES FOR PERSONAL USE AGAINST MOUNTAINEERING AND CLIMBING ACCIDENTS, NAMELY, NETS FOR PROTECTION AGAINST MOUNTAINEERING AND CLIMBING ACCIDENTS; CLOTHING AND GLOVES FOR PROTECTION AGAINST MOUNTAINEERING AND CLIMBING ACCIDENTS; AVALANCHE SENSORS, AVALANCHE DETECTORS; PROTECTIVE HELMETS, HELMETS FOR MOUNTAINEERING, HELMETS FOR CLIMBING, SPECTACLES (U.S. CLS. 21, 23, 26, 36 AND 38).

**CLASS 11—ENVIRONMENTAL CONTROL APPARATUS**

FOR ELECTRIC POCKET TORCHES FOR LIGHTING, ELECTRIC HEADBAND LAMPS, EMERGENCY LAMPS FOR MOUNTAIN SPORTS CLIMBING AND CLIMBING (U.S. CLS. 13, 21, 23, 31 AND 34).

**CLASS 18—LEATHER GOODS**

FOR ANIMAL SKINS, ANIMAL HIDES, TRUNKS AND TRAVELING BAGS, UMBRELLAS, PARASOLS AND WALKING STICKS, WHIPS, HARNESSES AND SADDLERY, ALPENSTOCKS AND BAGS FOR CLIMBERS; SPORTS BAGS; TRAVELING BAGS; LUGGAGE; MOUNTAINEERING STICKS; CHALK BAGS; BAGS FOR CAMPERS; RUCKSACKS; WAIST BAGS; HORSESHOES; METAL STIRRUPS (U.S. CLS. 1, 2, 3, 22 AND 41).

**CLASS 20—FURNITURE AND ARTICLES NOT OTHERWISE CLASSIFIED**

FOR TENT PEGS, NOT OF METAL; SLEEPING BAGS FOR CAMPING; CAMP BEDS; MATTRESSES FOR CAMPING (U.S. CLS. 2, 13, 22, 25, 32 AND 50).

**CLASS 22—CORDAGE AND FIBERS**

FOR ROPES, ROPE LADDERS, STRINGS, CAMOUFLAGE NETS FOR VISUAL AND RADAR USES, TENTS, TARPAULINS, SAILS, BAGS, NAMELY, MULTI-PURPOSE CLOTH BAGS, PADDING MATERIALS, NAMELY, ANIMAL HAIR, KAPOK, FEATHERS FOR STUFFING, SEAWEED FOR STUFFING; RAW FIBROUS TEXTILE MATERIALS; NON-METALLIC CABLES; SAFETY LANYARDS FOR FALL PROTECTION (U.S. CLS. 1, 2, 7, 19, 22, 42 AND 50).

**CLASS 25—CLOTHING**

FOR CLOTHING FOR MOUNTAINEERING AND CLIMBING, NAMELY, PANTS, SHIRTS, TROUSERS, JACKETS, GLOVES; FOOTWEAR, EXCEPT ORTHOPEDIC FOOTWEAR, FOR MOUNTAINEERING AND CLIMBING; HEADWEAR FOR MOUNTAINEERING AND CLIMBING; WATERPROOF CLOTHING, NAMELY, ANORAKS, PARKAS, WIND RESISTANT JACKETS, COATS FOR MOUNTAINEERING AND CLIMBING; SOLES FOR FOOTWEAR FOR MOUNTAINEERING AND CLIMBING; CLIMBING SHOES; BELTS; WATERPROOF OVERALLS, CLIMBING LEGGINGS (U.S. CLS. 22 AND 39).

**CLASS 28—TOYS AND SPORTING GOODS**

FOR SPORTS ARTICLES FOR MOUNTAINEERING AND CLIMBING, NAMELY, HANDLED ASCENDERS, DESCENDERS, SAFETY AND RAPPEL ROPES AND BINDINGS, CLIMBING HARNESSSES, HARNESSSES, CLIMBING PEG BOARDS (U.S. CLS. 22, 23, 38 AND 50).

**CLASS 35—ADVERTISING AND BUSINESS**

FOR RETAIL STORE SERVICES FEATURING SPORTS ARTICLES FOR MOUNTAINEERING AND CLIMBING, HANDLED JUMARS, DESCENDERS, SAFETY AND RAPPEL ROPES AND BINDINGS, CLIMBING HARNESSSES, HARNESSSES, CLIMBING BOARDS; ADVERTISING AGENCY SERVICES (U.S. CLS. 100, 101 AND 102).

WILLIAM BRECKENFELD, EXAMINING ATTORNEY

SN 79-075,414. SMS GMBH, FED REP GERMANY, FILED 9-29-2009.



PRIORITY DATE OF 4-7-2009 IS CLAIMED.  
OWNER OF INTERNATIONAL REGISTRATION 1019582 DATED 9-29-2009, EXPIRES 9-29-2019.

THE MARK CONSISTS OF A SOLID CIRCLE WITHIN A LARGER, INCOMPLETE CIRCLE, WHICH IS IN TURN WITHIN A LARGER, INCOMPLETE CIRCLE, WHICH IS IN TURN WITHIN A LARGER, INCOMPLETE CIRCLE.

**CLASS 6—METAL GOODS**

FOR COMMON METALS AND THEIR ALLOYS, NAMELY, CAST IRON, STEEL, COPPER INGOTS, ALUMINUM INGOTS, IRON ALLOYS, STEEL ALLOYS, COPPER ALLOYS AND ALUMINUM ALLOYS; METAL BUILDING MATERIALS, NAMELY, STRUCTURAL STEELS, SHEET PILING, SECTIONAL BEAMS AND PIPES MADE OF METAL; NON-ELECTRIC CABLES AND WIRES OF COMMON METAL; PIPES AND TUBES OF METAL (U.S. CLS. 2, 12, 13, 14, 23, 25 AND 50).

**CLASS 7—MACHINERY**

FOR MACHINES FOR THE TREATMENT, PROCESSING, AND PRODUCTION OF METALS AND PLASTICS, NAMELY, MILLING MACHINES AND GRINDING MACHINES, AND MACHINES UTILIZING ROTATIONAL MOTION FOR HIGH ENERGY SURFACE FINISHING AND MATERIAL TREATMENT, IN PARTICULAR, HEAVY, MEDIUM AND LIGHT SECTION ROLLING MILLS, COLD AND HOT MILLS, STRIP AND WIDE STRIP MILLS, PLATE AND SHEET MILLS, BLOOMING, SLABBING AND BILLET MILLS, UNIVERSAL MILLS, PLANETARY MILLS, MULTI-PURPOSE COLD MILLS, ROD, BAR AND TUBE MILLS, CONTINUOUS MILLS, REVERSING MILLS, PILGRIM MILLS, DETACHING MILLS AND MILLS FOR THE ROLLING OF STEEL, IRON, ALUMINUM AND COPPER OR FOR THE ROLLING OF ALLOYS OF THE SAME, AND STRUCTURAL PARTS FOR THE AFOREMENTIONED ROLLING

MILLS; ROLLING MILLS FOR WIRE, STEEL ROD ROLLING MILLS, BLOOM ROLLING MILLS, RAIL ROLLING MILLS, AND SECTION ROLLING MILLS, DRAWING MACHINES, WIRE RING PRESSES, METAL REELING MACHINES; MACHINES FOR MANUFACTURING, PROCESSING AND WORKING SEAMLESS AND WELDED PIPES, NAMELY, PIPE EXPANDING MACHINES, LARGE PIPE MANUFACTURING MACHINES, HOT AND COLD PIPE ROLLING MILLS, PRESSES, IN PARTICULAR, EXTRUSION PRESSES, IMPACT EXTRUSION, COLD EXTRUSION AND BACK-FLOW EXTRUSION PRESSES, CABLE SHEATHING PRESSES, STRAIGHTENING AND BENDING PRESSES, PLATE SHAPING PRESSES, DEEP-DRAWING PRESSES, MULTI-STAGE PRESSES, HYDRAULIC METAL POWDER PRESSES, AND STRUCTURAL PARTS THEREOF; FORGING MACHINES, IN PARTICULAR, OPEN-DIE FORGING MACHINES, AUTOMATIC FORGING HAMMERS, FORGING PRESSES, PIERCING PRESSES AND COUNTER BLOW HAMMERS, AND STRUCTURAL PARTS FOR THE AFOREMENTIONED FORGING MACHINES; CASTING MACHINES, IN PARTICULAR, CONTINUOUS STEEL SLAB CASTING MACHINES AND MACHINES FOR THE CONTINUOUS CASTING OF METALS, PLASTIC EXTRUSION AND PLASTIC MOLDING MACHINES, AND STRUCTURAL PARTS FOR THE AFOREMENTIONED CASTING MACHINES; ELECTRIC POWER GENERATION MACHINES FOR ROLLING, PRESSING, FORGING AND CASTING INSTALLATIONS; MACHINES FOR THE TREATMENT, PROCESSING, AND PRODUCTION OF METALS AND PLASTICS, NAMELY, ROLLING MILLS AND CONTINUOUS METAL CASTING MACHINES FEATURING COOLING APPARATUS IN THE NATURE OF WATER SPRAYERS AND AIR COOLERS AS INTEGRAL COMPONENTS THEREOF; HYDRAULIC DRIVING MACHINES, NAMELY, TORQUE CONVERTERS NOT FOR LAND VEHICLES; SUPPORTING CHAIN CONVEYORS AND HOISTS, ROLLER TABLES IN THE NATURE OF CONVEYORS, FILTERS IN THE NATURE OF INDUSTRIAL MACHINES FOR POSITIONING METAL AS IT IS BEING CUT, SCALE ELECTRIC WASHING MACHINES FOR INDUSTRIAL PURPOSES, AND CLEANING MACHINES FOR CLEANING ROLLER CONVEYORS, AND ROLLING MACHINES FOR ROLLING METALS; CONVEYORS FOR THE CONVEYING OF ROLLED, PRESSED, FORGED AND CAST ARTICLES TO AND FROM ROLLING, PRESSING, FORGING AND CASTING INSTALLATIONS; ELECTRIC WELDING MACHINES, IN PARTICULAR, PIPE WELDING MACHINES, BUTT-WELDING MACHINES; CUTTING MACHINES FOR CUTTING AND TRIMMING, LONGITUDINALLY OR TRANSVERSELY, ROLLED METAL PIPE, ROLLED PROFILES, INGOTS, AND STRIPS; FLAME CUTTING MACHINES FOR STRIPPING SCALE OFF INGOTS, BLOOMS AND STRIPS; MACHINES FOR FILLING AND EMPTYING BLAST FURNACES; MACHINES FOR TILTING, PIVOTING, AND MOVING CONVERTERS AND LADLES, NAMELY, CRANES AND MECHANICAL AND HYDRAULIC LIFTS FOR MANIPULATING CRUCIBLES FILLED WITH MOLTEN METAL SO THAT THE METALS CAN BE Poured INTO MOLDS OF A CONTINUOUS CASTER; ALL THE AFOREMENTIONED MACHINES FOR THE TREATMENT, PROCESSING, AND PRODUCTION OF METALS AND PLASTICS; MACHINES FOR THE CHEMICAL INDUSTRY, NAMELY, CHEMICAL FIBER DRYING MACHINES, EXTRACTING MACHINES FOR CHEMICAL PROCESSING; MACHINES FOR AGRICULTURE, NAMELY, COMBINES, HARVESTERS, THRESHERS, AND TILERS; MACHINES FOR MINING, IN PARTICULAR, EXCAVATORS, CUTTERS, EARTH AND BURDEN MOVERS, LOADERS, CUTTERS AND CONVEYORS; MACHINES FOR MINING, NAMELY, MINING SHAFT EXCAVATORS, HOISTS, SKIPS FOR LIFTING LARGE LOADS IN MINING OPERATIONS, WINDLASSES; MACHINES FOR MINING, NAMELY, INCLINED CONVEYORS, WINDING ENGINES IN THE NATURE OF HAULING ENGINES FOR DRIVING THE DRUM OVER WHICH A CABLE EXTENDING ALONG THE LENGTH OF A MINE IS WOUND, BUCKET CONVEYORS, CONVEYOR BELTS, MINE CAR FILLERS, UNLOADING MACHINES, AND WINDING TOWERS FOR CARRYING A DRIVE DRUM FOR MINING CABLES AT THE SURFACE FEATURING HEAD FRAMES AS INTEGRATED COMPONENTS THEREOF; MACHINES FOR MINING, NAMELY, HYDRAULIC AND PNEUMATIC CONVEYORS AND SOLIDS TRANSPORTERS; MACHINES FOR MINING, NAMELY, PIPELINE CONVEYORS; MA-

CHINES FOR MINING, NAMELY, WASTE DISPOSAL COMMINUTERS, CONVEYORS, LOADERS FOR LOADING CONTAINERS WITH RADIO-ACTIVE WASTE, TRANSPORTERS FOR RADIOACTIVE WASTE CONTAINERS; MACHINES FOR THE TREATMENT, PROCESSING AND PRODUCTION OF METALS AND PLASTICS, NAMELY, METAL COIL HANDLERS, METAL COIL WINDERS, METAL COIL CONVEYORS, METAL COIL PACKAGERS, METAL COIL STACKERS; MACHINES FOR THE TREATMENT, PROCESSING AND PRODUCTION OF METALS AND PLASTICS, NAMELY, CRANES, HOISTS AND CLAMPS BEING STRUCTURAL PARTS THEREOF; MACHINES FOR THE TREATMENT, PROCESSING AND PRODUCTION OF METALS AND PLASTICS, NAMELY, ROLLING MILL ROLL REPLACEMENT MACHINES; MOTORS AND ENGINES EXCEPT FOR LAND VEHICLES, NAMELY, ELECTRIC MOTORS OR ELECTRIC GEAR MOTORS; MACHINE COUPLING AND TRANSMISSION COMPONENTS NOT FOR LAND VEHICLES, NAMELY, HYDRAULIC AND MECHANICAL TRANSMISSIONS FOR MACHINERY AND STRUCTURAL PARTS THEREFOR (U.S. CLS. 13, 19, 21, 23, 31, 34 AND 35).

### **CLASS 9—ELECTRICAL AND SCIENTIFIC APPARATUS**

FOR WEIGHING, MEASURING, SIGNALING, AND CHECKING APPARATUS AND INSTRUMENTS FOR CONDUCTING, SWITCHING, TRANSFORMING, ACCUMULATING, REGULATING OR CONTROLLING ELECTRICITY, NAMELY, STRIP TENSION DYNAMOMETERS, STRIP FLATNESS METERS, THERMOMETERS, SPEEDOMETERS, PRESSURE GAUGES, ANGLE GAUGES, DISTANCE METERS, ROUGHNESS GAUGES, AND ELECTRIC AND ELECTRONIC CONTROLLERS FOR MACHINES IN THE NATURE OF FLATNESS CONTROLLERS, ROUGHNESS CONTROLLERS, PRESSURE CONTROLLERS AND TENSIONING CONTROLLERS FOR INFLUENCING THE PROPERTIES OF ROLLED STEEL; ELECTRONIC CONTROL PANELS FOR ROLLING MILLS, ELECTRICAL AND MAGNETIC DETECTORS FOR MONITORING THE PROPERTIES OF ROLLED STEEL; FREQUENCY METERS; CALCULATING MACHINES; DATA PROCESSORS, AND COMPUTERS FOR USE IN OPERATING AND CONTROLLING OPERATIONS OF METALLURGICAL PLANTS AND ROLLING MILLS; PRERECORDED MAGNETIC DATA CARRIERS FEATURING COMPUTER APPLICATION SOFTWARE FOR CONTROLLING AND REGULATING MACHINES AND MACHINE TOOLS FOR THE METAL INDUSTRY; COMPUTERS FEATURING PROGRAMS FOR CONTROLLING ROLLING MILLS, FURNACE PLANTS, CONTINUOUS CASTING MACHINES; COMPUTER PROGRAMS FOR CONTROLLING AND REGULATING MACHINES FOR THE METALLURGICAL INDUSTRY, MACHINES FOR THE STEEL INDUSTRY, CONTINUOUS CASTING MACHINES, ROLLING MACHINES, FORGING MACHINES, PRESSING MACHINES AND MACHINES FOR PROCESSING SYNTHETIC MATERIALS (U.S. CLS. 21, 23, 26, 36 AND 38).

### **CLASS 11—ENVIRONMENTAL CONTROL APPARATUS**

FOR APPARATUS FOR HEATING, STEAM GENERATING, COOKING, REFRIGERATING, DRYING, VENTILATING, AND WATER SUPPLY PURPOSES, NAMELY, FURNACES FOR METALLURGICAL PLANTS, STEEL MILLS, CONTINUOUS CASTING PLANTS, AND FORGING AND PRESSING PLANTS; INDUSTRIAL WATER RECIRCULATION COOLING AND HEATING SYSTEMS FOR ROLLING, PRESSING, FORGING AND CASTING INSTALLATIONS, COMPRISING FURNACES, COOLING TOWERS, COOLING FANS, HEAT INSULATION, WATER ROLL COOLERS, STRIP PREHEATERS, SPRAY WATER COOLING SECTIONS SPRAYERS, AND SLAB COOLING WHEELS; OIL AND WATER TREATMENT, COOLING, AND PURIFYING SYSTEMS FOR ROLLING, PRESSING, FORGING AND CASTING INSTALLATIONS IN THE METALLURGICAL AND STEEL MILL INDUSTRIES, COMPRISING SEPARATORS FOR THE CLEANING AND PURIFICATION OF LIQUIDS, WATER SEPARATORS, WATER FILTERS, COOLANT PURIFYING DEVICES, WATER NEUTRALIZATION PLANTS, AND WASHING BRUSHING MACHINES; APPARATUS FOR HEATING, NAMELY,

WATER HEATERS FOR INDUSTRIAL PURPOSES, HEAT SINKS FOR USE IN INDUSTRIAL HEATING APPARATUS, ELECTRIC HEATING PANELS USED FOR INDOOR HEATING PURPOSES; ELECTRIC HEATERS AND FURNACES FOR ROLLING STOCK, NAMELY, FOR ROLLING METAL PRODUCTS SUBJECT TO ROLLING IN A ROLLING MILL, AND FOR CONTINUOUS CASTING PLANTS; STEAM GENERATORS; REFRIGERATED MERCHANDISE DISPLAY CASES; AIR COOLING APPARATUS FOR USE IN THE METALLURGICAL AND STEEL MILL INDUSTRIES IN THE NATURE OF DEVICES FOR COOLING THE ENVIRONMENT IN AN INDUSTRIAL SETTING; VENTILATING AND DRYING FANS FOR COMMERCIAL AND INDUSTRIAL USE; VENTILATING LOUVERS; COOLING WATER CIRCUIT INSTALLATIONS, NAMELY, WATER COOLING TOWERS; AIR COOLERS FOR METALLURGICAL PLANTS, STEEL MILLS, CONTINUOUS CASTING PLANTS, ROLLING MILLS, AND FORGING AND PRESSING PLANTS; SMELTING MACHINES; INDUSTRIAL AIR FILTER MACHINES FOR USE WITH ROLLING, PRESSING, FORGING, AND CASTING INSTALLATIONS (U.S. CLS. 13, 21, 23, 31 AND 34).

#### **CLASS 35—ADVERTISING AND BUSINESS**

FOR ADVERTISING SERVICES; BUSINESS MANAGEMENT CONSULTANCY; BUSINESS ADMINISTRATION; PROVIDING OFFICE FUNCTIONS (U.S. CLS. 100, 101 AND 102).

#### **CLASS 37—CONSTRUCTION AND REPAIR**

FOR INSTALLATION AND REPAIR OF INDUSTRIAL AND MACHINERY SYSTEMS, NAMELY, MACHINES FOR THE METALLURGICAL INDUSTRY, MACHINES FOR THE STEEL MILL INDUSTRY, CONTINUOUS CASTING MACHINES, ROLLING MACHINES FOR THE ROLLING OF METALS, FORGING MACHINES, PRESSES FOR METALS, MACHINES FOR THE WORKING AND PROCESSING OF PLASTICS, MACHINE TOOLS, ENGINES AND MOTORS, EXCEPT ENGINES FOR LAND VEHICLES, CLUTCHES AND COUPLINGS AND DEVICES FOR POWER TRANSFER, EXCEPT FOR LAND VEHICLES (U.S. CLS. 100, 103 AND 106).

#### **CLASS 40—MATERIAL TREATMENT**

FOR TREATMENT OF MATERIALS, NAMELY, METAL TREATING, ROLLING, FORGING, GRINDING, PARTS MOLDING, SWAGING, TEMPERING, CASTING, MILLING, PLANING, COATING, CUTTING, TURNING, SURFACE REFINING BY ABRASION, AND PLATING OF METALS TO THE ORDER AND SPECIFICATION OF OTHERS (U.S. CLS. 100, 103 AND 106).

#### **CLASS 42—SCIENTIFIC AND COMPUTER SERVICES**

FOR SCIENTIFIC RESEARCH IN THE FIELD OF THE TREATMENT, PROCESSING, AND PRODUCTION OF METALS AND PLASTICS; TECHNOLOGICAL CONSULTING SERVICES IN THE FIELD OF THE TREATMENT, PROCESSING, AND PRODUCTION OF METALS AND PLASTICS; DESIGN AND DEVELOPMENT OF COMPUTERS AND COMPUTER SOFTWARE FOR OTHERS; TECHNICAL CONSULTANCY IN RELATION TO THE OPERATION OF MACHINES FOR THE METALLURGICAL INDUSTRY, MACHINES FOR THE STEEL MILL INDUSTRY, CONTINUOUS CASTING PLANTS, ROLLING MACHINES, FORGING MACHINES, PRESSING MACHINES, TECHNICAL CONSULTANCY FOR THE METALLURGICAL INDUSTRY REGARDING TESTING, ANALYSIS AND EVALUATION OF MACHINERY FOR THE STEEL MILL INDUSTRY, INCLUDING CONTINUOUS CASTING PLANTS, ROLLING MACHINES, FORGING MACHINES, PRESSING MACHINES (U.S. CLS. 100 AND 101).

JAMES MACFARLANE, EXAMINING ATTORNEY

SN 79-075,741. ZICA D.O.O., HR-10000 ZAGREB, CROATIA, FILED 3-31-2009.

## **PRESS THE PRESIDENT**

THE MARK CONSISTS OF STANDARD CHARACTERS WITHOUT CLAIM TO ANY PARTICULAR FONT, STYLE, SIZE, OR COLOR.

PRIORITY DATE OF 12-8-2008 IS CLAIMED.

OWNER OF INTERNATIONAL REGISTRATION 1020596 DATED 3-31-2009, EXPIRES 3-31-2019.

#### **CLASS 25—CLOTHING**

FOR CLOTHING, NAMELY, T-SHIRTS, JACKETS, PANTS, DRESSES, SKIRTS, SHORTS, HOODED SWEATSHIRTS, LOUNGEWEAR, BLOUSES, COATS, JACKETS, SLEEPWEAR, UNDERWEAR, SWEATERS, JEANS, SOCKS AND HOSIERY, SWIMWEAR, SUITS; FOOTWEAR; HEADGEAR, NAMELY, HATS, CAPS, VISORS, BERETS, BOWLERS, FEDORAS (U.S. CLS. 22 AND 39).

#### **CLASS 35—ADVERTISING AND BUSINESS**

FOR RETAIL STORE SERVICES AND RETAIL STORES SERVICES VIA THE INTERNET FEATURING CLOTHING, CHILDREN'S CLOTHING, FOOTWEAR, HEADGEAR, JEWELRY, WATCHES, MAGAZINES, BOOKS, MUSIC, VIDEOTAPES, AUDIOCASSETTES, COMPACT DISCS, FLOPPY DISCS AND CD-ROMS, DVD MOVIES, GAMES, MUSICAL INSTRUMENTS, VIDEO GAMES, GAMING EQUIPMENT, PRINTED MATTERS, PHONOGRAPHS, RECORDED MUSIC, TOYS, ELECTRONIC PUBLICATIONS AND GREETING CARDS, COMPUTERS, OFFICE EQUIPMENT AND SUPPLIES, COMPUTER ACCESSORIES AND COMPONENTS, COMPUTER PRINTERS AND SUPPLIES, SOFTWARE, ELECTRONICS, HOUSEHOLD ELECTRONIC APPLIANCES, HEALTH AND BEAUTY SUPPLIES, SOAPS, PERFUMERY, COSMETICS, HOME AND GARDEN SUPPLIES, POTS, TABLEWARE, KITCHEN AND HOUSEHOLD UTENSILS, PLAYTHINGS, EXERCISE AND FITNESS EQUIPMENT, ATHLETIC AND RECREATION CLOTHING, TOOLS, AUTO AND INDUSTRIAL TOOLS AND EQUIPMENT, PLUMBING FIXTURES, LIGHTING AND ELECTRICAL FIXTURES, POWER EQUIPMENT, MANUAL AND POWER TOOLS, AUTOMOTIVE EQUIPMENT; SERVICES FOR ONLINE ELECTRONIC RESEARCH, ORDERING AND DISTRIBUTION IN THE FRAMEWORK OF RETAIL AND WHOLESALE OF CONVENIENCE GOODS, NAMELY, WHOLESALE ORDERING SERVICES, WHOLESALE DISTRIBUTORSHIPS AND RETAIL STORE SERVICES ALL FEATURING CONVENIENCE STORE ITEMS; DISSEMINATION OF ADVERTISING MATTER ONLINE ON A COMPUTER NETWORK FOR THIRD PARTIES; PROMOTIONAL SERVICES FOR THIRD PARTIES, NAMELY, PROMOTING THE GOODS AND SERVICES OF OTHERS BY DISTRIBUTING ADVERTISING MATERIALS THROUGH A VARIETY OF METHODS (U.S. CLS. 100, 101 AND 102).

#### **CLASS 38—COMMUNICATION**

FOR TELECOMMUNICATIONS, NAMELY, THE ELECTRONIC TRANSMISSION OF DATA AND INFORMATION, PROVIDING TELECOMMUNICATIONS CONNECTIONS TO A GLOBAL COMPUTER NETWORK, TELECOMMUNICATION ACCESS SERVICES; BROADCASTING OF AUDIO, VIDEO AND MULTIMEDIA BROADCASTING SERVICES VIA THE INTERNET AND OTHER COMMUNICATIONS NETWORKS, NAMELY, UPLOADING, POSTING, SHOWING, DISPLAYING, TAGGING AND ELECTRONICALLY TRANSMITTING INFORMATION, AUDIO AND VIDEO CLIPS; WEB CASTING SERVICES; PROVIDING PORTAL SERVICES FOR SHARING VIDEOS, NAMELY, STREAMING OF VIDEO MATERIAL ON THE INTERNET, ELECTRONIC EXCHANGE OF DATA STORED IN DATABASES ACCESSIBLE VIA TELECOMMUNICATION NETWORKS; DISSEMINATION SERVICES, NAMELY UPLOADING TO A SERVER IN THE NATURE OF PROVIDING MULTIPLE USE ACCESS TO GLOBAL COMPUTER INFORMATION NETWORKS FOR THE TRANSFER AND DISSEMINATION OF A WIDE RANGE OF IN-

FORMATION BY MEANS OF POSTING MESSAGES, DISPLAYING VARIOUS CONTENTS, EXHIBITIONS AND PROVIDING ACCESS TO VARIOUS ELECTRONIC CONTENTS BY TAGGING; INTERNET ACCESS PROVIDER SERVICES AND PROVIDING ON-LINE FORUMS FOR TRANSMISSION OF MESSAGES AMONG COMPUTER USERS; PROVISION OF ELECTRONIC TELECOMMUNICATIONS CONNECTIONS; TRANSMISSION OF MESSAGES, DATA AND CONTENT VIA THE INTERNET AND ANY OTHER COMPUTER AND COMMUNICATION NETWORK; PROVIDING ONLINE DISCUSSION FORUMS, ONLINE CHAT ROOMS, AND ELECTRONIC BULLETIN BOARDS FOR THE TRANSMISSION OF MESSAGES, COMMENTS OR MULTIMEDIA CONTENT BETWEEN USERS IN THE FIELD OF GENERAL INTERESTS; PROVIDING MULTIPLE USE ACCESS TO GLOBAL COMPUTER INFORMATION NETWORKS FOR THE ELECTRONIC DISSEMINATION OF MULTIMEDIA CONTENT, VIDEOS, FILMS, IMAGES, STAGED EVENTS, TEXTS, PHOTOGRAPHS, GAMES, AND CONTENT PRODUCED BY USERS, AUDIO CONTENT AND INFORMATION; PROVIDING SERVICES INCLUDED IN THIS CLASS TO USERS OF ONLINE CHAT ROOMS, IN CONNECTION WITH SENDING, SEARCHING, VIEWING, EXCHANGING, CRITICIZING, EVALUATING AND COMMENTARIES ON VIDEOS AND OTHER MULTIMEDIA CONTENT, NAMELY, PROVIDING INTERNET CHAT ROOMS AND ELECTRONIC BULLETIN BOARDS FOR TRANSMISSION OF MESSAGES AMONG USERS IN THE FIELD OF GENERAL INTEREST; DISTRIBUTING IN THE NATURE OF TRANSMITTING TELEVISION PROGRAMS FOR AUDIOVISUAL DIGITAL BROADCASTING OVER THE INTERNET (U.S. CLS. 100, 101 AND 104).

#### **CLASS 41—EDUCATION AND ENTERTAINMENT**

FOR TRAINING AND VOCATIONAL TRAINING VIA COMMUNICATION AND COMPUTER NETWORKS INCLUDING THE GLOBAL COMPUTER NETWORK, NAMELY, CONDUCTING CLASSES, SEMINARS, CONFERENCES, WORKSHOPS FEATURING MULTIMEDIA, VIDEOS, FILMS, IMAGES, STAGED EVENTS, TEXTS, PHOTOGRAPHS AND GAMES, ALL OF WHICH ARE INSTRUCTIONAL IN NATURE IN THE FIELDS OF MEDIA, COMPUTER TECHNOLOGIES, INTERNET TECHNOLOGIES, COMMUNICATIONS AND ARTISTIC EXPRESSION OF ANY KIND; ENTERTAINMENT SERVICES AND EDUCATION SERVICES, NAMELY, PROVIDING A WEBSITE FEATURING AUDIO CLIPS, VIDEO CLIPS, MUSICAL PERFORMANCES, MUSICAL VIDEOS, FILM CLIPS, PHOTOGRAPHS, OTHER MULTIMEDIA MATERIALS, AND INFORMATION IN THE FIELD OF ENTERTAINMENT, SPORTING AND CULTURAL ACTIVITIES, FOR ENTERTAINMENT PURPOSES, NAMELY, ORGANIZING COMMUNITY SPORTING AND CULTURAL EVENTS, ORGANIZING AND CONDUCTING FANTASY SPORTS CONTESTS AND LEAGUES; PROVIDING AN INTERNET WEBSITE PORTAL IN THE FIELD OF ENTERTAINMENT, CULTURAL AND SPORTING EVENTS FOR SHARING VIDEO CONTENT INTENDED FOR ENTERTAINMENT AND EDUCATION; EDUCATIONAL SERVICES VIA THE INTERNET, IN THE FORM OF WEB BASED SEMINARS FEATURING MULTIMEDIA CONTENT, ALL USED AS INSTRUCTIONAL AIDES IN THE FORM OF VIDEOS, FILMS, IMAGES, STAGED EVENTS, TEXTS, PHOTOGRAPHS, GAMES, CONTENT PRODUCED BY USERS, AUDIO CONTENT, ALL OF WHICH ARE INSTRUCTIONAL IN NATURE IN THE FIELD OF MEDIA, COMPUTER TECHNOLOGIES, INTERNET TECHNOLOGIES, COMMUNICATIONS, AND PERFORMING ARTS; BROADCASTING SERVICES FOR DISSEMINATION OF AUDIOVISUAL AND MULTIMEDIA DIGITAL CONTENT FOR ENTERTAINMENT PURPOSES, NAMELY, PROVIDING A CONTINUING VARIETY NEWS, COMEDY, SHOW BROADCAST OVER TELEVISION, SATELLITE, AUDIO AND VIDEO MEDIA PROVIDED OVER COMPUTER NETWORKS; PROVIDING MULTIMEDIA ENTERTAINMENT CONTENT AND EDUCATIONAL CONTENT INTENDED FOR ALL TYPES OF USERS, NAMELY, PROVIDING ENTERTAINMENT INFORMATION AND EDUCATION INFORMATION VIA COMMUNICATION AND COMPUTER NETWORKS INCLUDING THE GLOBAL COMPUTER NETWORK (U.S. CLS. 100, 101 AND 107).

MARIAM MAHMOUDI, EXAMINING ATTORNEY

SN 79-075,792. CAMILLE BAUER AG, SWITZERLAND, FILED 4-3-2009.

# **CAMILLE BAUER**

THE MARK CONSISTS OF STANDARD CHARACTERS WITHOUT CLAIM TO ANY PARTICULAR FONT, STYLE, SIZE, OR COLOR.

OWNER OF INTERNATIONAL REGISTRATION 0642771 DATED 9-12-1995, EXPIRES 9-12-2015.

THE NAME(S), PORTRAIT(S), AND/OR SIGNATURE(S) SHOWN IN THE MARK DOES NOT IDENTIFY A PARTICULAR LIVING INDIVIDUAL.

THE WORDING "CAMILLE BAUER" HAS NO MEANING IN A FOREIGN LANGUAGE.

#### **CLASS 9—ELECTRICAL AND SCIENTIFIC APPARATUS**

FOR LIMITING VALUE DETECTORS, NAMELY, SIGNAL PROCESSORS FOR DETECTION OF LIMIT VALUES, LIMITING VALUES, INSTRUMENT DETECTION LIMITS, AND LIMITS OF QUANTIFICATION; SENSORS FOR LIMITING VALUE SIGNALS; ELECTRICAL TRANSDUCERS, LEVEL INDICATORS FOR QUANTITY MEASUREMENT; MONITOR SIGNAL AMPLIFIERS; TRANSDUCERS FOR ELECTRICAL VARIABLES, ANGLE ELECTRICAL TRANSDUCERS, TEMPERATURE ELECTRICAL TRANSDUCERS, INTERFACES ELECTRICAL TRANSDUCERS; VIDEO RECORDERS; TEMPERATURE CONTROLLERS FOR LIMITING VALUE DETECTORS, RECTIFIERS; MEASURING APPARATUS FOR ELECTRICAL, MECHANICAL, PHYSICAL AND GEOMETRICAL VALUES WITH THEIR CONVERSION TO ELECTRICAL ANALOGUE OR DIGITAL OUTPUT SIGNALS; PROGRAM-CONTROLLED SIGNAL PROCESSORS FOR SWITCHING POWER; POWER AMPLIFIERS FOR SIGNALS, LIMITS, VALUES, POWER, ENERGY, MONITORING, ANALYSIS, CONVERSION, AND TRANSFORMATION; SIGNAL BAND SEPARATORS FOR USE IN POWER DISTRIBUTION AND SUPPLY, POWER GENERATION, POWER PLANTS, HYDRO-ELECTRIC PLANTS, SHIP BUILDING, FOOD AND BEVERAGE, CHEMICAL AND PETROCHEMICAL INDUSTRY; POWER SUPPLY APPARATUS, NAMELY, POWER CABLES, POWER SWITCHES, POWER AMPLIFIER, AUXILIARY POWER UNITS FOR SUPPLYING ELECTRICAL POWER AND POWER CORDS; MEASURING INSTRUMENTS RECORDING DATA CONTINUOUSLY, NAMELY, ELECTRONIC DATA CHART RECORDERS, AND RECORDING DATA DISCONTINUOUSLY, NAMELY, ELECTRONIC DATA POINT RECORDERS; INDICATING APPARATUS, NAMELY, ELECTRONIC TESTING APPARATUS FOR TESTING THE ACCURACY OF MEASURING EQUIPMENT; FREQUENCY INDICATING APPARATUS, NAMELY, ELECTRONIC APPARATUS FOR MEASURING WAVE FREQUENCIES, MEASURING APPARATUS, NAMELY, CLAMP METERS FOR MEASURING ELECTRICITY; VALVE CONTROL UNITS, NAMELY, CONTROL VALVES FOR REGULATING THE FLOW OF GASES AND LIQUIDS (U.S. CLS. 21, 23, 26, 36 AND 38).

#### **CLASS 42—SCIENTIFIC AND COMPUTER SERVICES**

FOR ENGINEERING SERVICES; MEASUREMENT EVALUATIONS OF ELECTROMAGNETIC COMPATIBILITY IN THE FIELD OF POWER DISTRIBUTION AND SUPPLY, POWER GENERATION, ENGINEERING, PROCESS MEASUREMENT, SHIP BUILDING, ENGINEERING, FOOD AND BEVERAGE, CHEMICAL AND PETROCHEMICAL INDUSTRY (U.S. CLS. 100 AND 101).

KAPIL BHANOT, EXAMINING ATTORNEY

SN 79-076,366. BEIJING TONGYIZHONG SPECIALTY; FIBRE TECHNOLOGY & DEVELOPMENT CO., LTD., BEIJING, CHINA, FILED 11-4-2009.

SN 79-076,378. CLARIANT PRODUKTE (DEUTSCHLAND) GMBH, 65929 FRANKFURT, FED REP GERMANY, FILED 10-29-2009.

# DOYENTRONTEX

PRIORITY DATE OF 5-20-2009 IS CLAIMED.  
OWNER OF INTERNATIONAL REGISTRATION 1022182 DATED 11-4-2009, EXPIRES 11-4-2019.  
THE MARK CONSISTS OF THE WORDING "DOYENTRONTEX" IN STYLIZED FONT.

## CLASS 9—ELECTRICAL AND SCIENTIFIC APPARATUS

FOR GLOVES FOR PROTECTION AGAINST ACCIDENTS, NAMELY, PROTECTIVE WORK GLOVES; CLOTHING FOR PROTECTION AGAINST ACCIDENTS, IRRADIATION AND FIRE, NAMELY, PROTECTIVE CLOTHING; PROTECTIVE HELMETS; BULLET-PROOF WAISTCOATS; PROTECTIVE HELMETS; NETS FOR PROTECTION AGAINST ACCIDENTS; SAFETY NETS; SAFETY RESTRAINTS, OTHER THAN FOR VEHICLE SEATS AND SPORTS EQUIPMENT; SHOES FOR PROTECTION AGAINST ACCIDENTS, IRRADIATION AND FIRE (U.S. CLS. 21, 23, 26, 36 AND 38).

## CLASS 10—MEDICAL APPARATUS

FOR SURGICAL APPARATUS AND INSTRUMENTS; ARTIFICIAL LIMBS; ARTIFICIAL EYES; ARTIFICIAL TEETH; SUTURE MATERIALS; SURGICAL IMPLANTS COMPRISING ARTIFICIAL MATERIALS (U.S. CLS. 26, 39 AND 44).

## CLASS 12—VEHICLES

FOR ANTI-THEFT DEVICES FOR MOTOR CARS; ANTI-THEFT ALARMS FOR VEHICLES; BODIES FOR VEHICLES; MILITARY VEHICLES FOR TRANSPORT, NAMELY, MILITARY TRUCKS; CARS; DOOR PANELS FOR VEHICLES; UNDERCARRIAGES FOR VEHICLES; SAFETY BELTS FOR VEHICLE SEATS; PARACHUTES (U.S. CLS. 19, 21, 23, 31, 35 AND 44).

## CLASS 22—CORDAGE AND FIBERS

FOR TEXTILE FIBERS; ROPES; ROPES, NOT OF METAL; FISHING NETS; STRING; SASH CORDS; SAILS; TWINE FOR NETS; CAR TOWING ROPES (U.S. CLS. 1, 2, 7, 19, 22, 42 AND 50).

## CLASS 24—FABRICS

FOR NON-WOVEN TEXTILE FABRICS; KNITTED FABRIC; FABRICS FOR TEXTILE USE; DOOR CURTAINS; FABRIC IMPERVIOUS TO GASES FOR AERONAUTICAL BALLOONS; FILTERING MATERIALS OF TEXTILE, NAMELY, MESH-WOVEN FABRICS; ADHESIVE FABRIC FOR APPLICATION BY HEAT (U.S. CLS. 42 AND 50).

## CLASS 28—TOYS AND SPORTING GOODS

FOR MACHINES FOR PHYSICAL EXERCISES, NAMELY, EXERCISE MACHINES; SAILBOARDS; CLIMBERS' HARNESS; BATS FOR GAMES; FISHING TACKLE; GUTS FOR RACKETS; STRINGS FOR RACKETS (U.S. CLS. 22, 23, 38 AND 50).  
EVELYN BRADLEY, EXAMINING ATTORNEY

# SANODYE

THE MARK CONSISTS OF STANDARD CHARACTERS WITHOUT CLAIM TO ANY PARTICULAR FONT, STYLE, SIZE, OR COLOR.

OWNER OF INTERNATIONAL REGISTRATION 1022211 DATED 10-29-2009, EXPIRES 10-29-2019.

THE ENGLISH TRANSLATION OF THE WORD "SANO" IN THE MARK IS "HEALTH".

## CLASS 1—CHEMICALS

FOR CHEMICALS FOR THE TEXTILE, LEATHER AND PAPER INDUSTRY AS WELL AS INDUSTRIAL CHEMICALS FOR ALUMINIUM PRODUCTION, EXCEPT THOSE FOR MOLTEN ALUMINIUM (U.S. CLS. 1, 5, 6, 10, 26 AND 46).

## CLASS 2—PAINTS

FOR PAINTS, VARNISHES, LACQUERS; PRESERVATIVES AGAINST RUST IN THE NATURE OF COATINGS; PRESERVATIVES AGAINST DETERIORATION OF WOOD; COLOURANTS; MORDANT DYES; RAW NATURAL RESINS; COLOURANTS FOR DYEING ALUMINIUM; AUXILIARY GOODS FOR DYEING, NAMELY, WOOD DYES, NATURAL RESINS AND COLOURANTS FOR ALUMINIUM, ANILINE DYES; ALIZARIN NATURAL DYES AND OTHER COLOURANTS (U.S. CLS. 6, 11 AND 16).

## CLASS 16—PAPER GOODS AND PRINTED MATTER

FOR PAPER, CARDBOARD AND GOODS MADE FROM PAPER AND CARDBOARD, NAMELY, BOXES, PRINTED MATTER, NAMELY, INDUSTRIAL TRADE PUBLICATIONS IN THE NATURE OF MAGAZINES ABOUT THE COAL MINING INDUSTRY, BOOKS ABOUT THE MOTION PICTURE FILM INDUSTRY; BOOKBINDING MATERIAL, NAMELY, BOOKBINDING TAPE; PHOTOGRAPHS; STATIONERY; ADHESIVES FOR STATIONERY OR HOUSEHOLD PURPOSES; ARTISTS' MATERIALS, NAMELY, PAINTBRUSHES; TYPEWRITERS; OFFICE REQUISITES, NAMELY, STAPLERS; PRINTED INSTRUCTIONAL AND TEACHING MATERIAL IN THE FIELD OF CHEMISTRY; PLASTIC MATERIALS FOR PACKAGING, NAMELY, PLASTIC BAGS FOR PACKAGING; PRINTERS' TYPE; PRINTING BLOCKS; PAMPHLETS ON THE SUBJECT OF CHEMICAL PRODUCTS; PROPAGANDA BROCHURES AND MANUALS PREPARED FOR OTHERS FOR THEIR ADVERTISING NEEDS (U.S. CLS. 2, 5, 22, 23, 29, 37, 38 AND 50).

**CLASS 35—ADVERTISING AND BUSINESS**

FOR ADVERTISING; BUSINESS MANAGEMENT OF INFORMATION AND MANAGEMENT OF DATA BANKS VIA COMPUTERS; SERVICES IN CONNECTION WITH DATA BANKS, NAMELY, COMPILATION, ORGANISATION AND SYSTEMIZATION OF INFORMATION IN DATA BANKS; ADMINISTRATIVE PROCESSING OF ORDERS AND INFORMATION PERTAINING TO CHEMICALS, PIGMENTS, COLOURANTS AND AUXILIARY GOODS FOR DYEING IN THE FIELD OF ADVERTISING AND WHOLESALE TRADE, NAMELY, BRINGING TOGETHER CHEMICALS, PIGMENTS, COLOURANTS AND AUXILIARY GOODS FOR DYEING, EXCLUDING THEIR TRANSPORT, FOR THIRD PARTIES, ENABLING CONSUMERS TO VIEW AND PURCHASE THEM BY ORDERING THEM FROM A WHOLESALER; ADVERTISING FOR CHEMICALS, PIGMENTS, COLOURANTS AND AUXILIARY GOODS FOR DYEING VIA GLOBAL COMPUTER NETWORKS AND THE INTERNET; WHOLESALE STORE SERVICES, NAMELY, THE BRINGING TOGETHER FOR THE BENEFIT OF THIRD PARTIES CHEMICALS, PIGMENTS, COLOURANTS AND AUXILIARY GOODS FOR DYEING, EXCLUDING THEIR TRANSPORT, FOR THIRD PARTIES, AND ENABLING CONSUMERS TO VIEW AND BUY THEM FROM A WHOLESALER, ONLINE WHOLESALE STORE SERVICES FEATURING THE BRINGING TOGETHER FOR THE BENEFIT OF THIRD PARTIES CHEMICALS, PIGMENTS, COLOURANTS AND AUXILIARY GOODS FOR DYEING, EXCLUDING THEIR TRANSPORT, AND ENABLING CONSUMERS TO VIEW AND PURCHASE THEM FROM A WHOLESALER BY MEANS OF GLOBAL COMPUTER NETWORKS AND THE INTERNET (U.S. CLS. 100, 101 AND 102).

**CLASS 42—SCIENTIFIC AND COMPUTER SERVICES**

FOR SERVICES OF A CHEMIST, SERVICES OF A CHEMICAL ENGINEER, SERVICES OF A CHEMICAL LABORATORY, TECHNICAL CONSULTING IN THE FIELD OF CHEMISTRY AND CHEMICAL ENGINEERING, PARTICULARLY CONSULTING IN CONNECTION WITH IMPLEMENTATION OF PRODUCTION PROCESSES BY TECHNICAL INSTALLATIONS; CONSULTING IN THE FIELD OF CHEMISTRY AND LABORATORY-RELATED COLOR ANALYSIS TECHNOLOGY, NAMELY, COLOR ANALYSIS CONSULTATION FEATURING ANALYSIS OF COLORS FROM LABORATORY RESULTS, ANALYZING COLOR ASSORTMENTS AND ANALYSIS IN CONNECTION WITH THE STANDARDIZATION OF COLORS; CHEMISTRY-RELATED SCIENTIFIC CONSULTING AND RESEARCH SERVICES IN THE FIELD OF INDUSTRIAL USE OF CHEMICALS, PIGMENTS AND COLORANTS; DESIGNING, INSTALLING, MAINTAINING AND UPDATING SOFTWARE SPECIFIC TO CUSTOMERS IN THE FIELD OF INDUSTRIAL USE OF CHEMICALS, PIGMENTS AND COLORANTS (U.S. CLS. 100 AND 101).

MAUREEN DALL, EXAMINING ATTORNEY

**CLASS 5—PHARMACEUTICALS**

FOR BIOLOGICAL PREPARATIONS FOR CELL CULTURES; CELL CULTURE MEDIA, NAMELY, CULTURE MEDIA FOR ENDOTHELIAL AND MYOCARDIAC CELLS; CULTURE MEDIA FOR CELL GROWTH FOR MEDICAL BIOTECHNOLOGY, NAMELY, CULTURE MEDIA FOR GROWING AND REGENERATING ENDOTHELIAL AND MYOCARDIAC CELLS; BIOLOGICAL REAGENTS FOR MOLECULAR BIOLOGY; CHEMICAL REAGENTS FOR MEDICAL USE FOR BIOLOGICAL PROCESSES; CARRIERS OF CULTURE MEDIA FOR MEDICAL USE, NAMELY, ISCOVE'S MODIFIED DUL-BECCO'S MEDIUM, USED FOR RAPIDLY PROLIFERATING HIGH DENSITY CELL CULTURES; CELLULAR FUNCTION ACTIVATING AGENTS, NAMELY, CELL GROWTH FACTORS, HEMATOPOIETIC FACTORS, SERUMS, NAMELY, HUMAN AND ANIMAL SERUMS FOR CELL CULTURE; ANTIBODIES, NAMELY, MONOCLONAL ANTIBODIES FOR DETECTION AND TREATMENT OF PATHOLOGIES; ALL THESE PRODUCTS BEING FOR MEDICAL USE (U.S. CLS. 6, 18, 44, 46, 51 AND 52).

**CLASS 10—MEDICAL APPARATUS**

FOR MEDICAL APPARATUS AND INSTRUMENTS, NAMELY, INTRAVASCULAR CELL REINJECTION CATHETERS; APPARATUS FOR HUMAN CELL CULTURE, NAMELY, MEDICAL DEVICE FOR PROVIDING HUMAN CELL CULTURE DIAGNOSIS AND TREATMENT; CELL ANALYZERS FOR MEDICAL TREATMENT AND DIAGNOSTIC USE; MEDICAL DEVICE FOR PRODUCTION OF HUMAN CELL GRAFTS, NAMELY, MEDICAL DEVICE ALLOWING IN VITRO STEM CELL EXPANSION FOR THERAPEUTIC USE; INSTRUMENTS FOR CELL CULTURE, NAMELY, MEDICAL INSTRUMENTS USED FOR CELL CULTURE DIAGNOSIS AND TREATMENT; MEDICAL DEVICE FOR HUMAN CELL SELECTION, NAMELY, MEDICAL DEVICE FOR HUMAN CELL IMMUNE SELECTION USED FOR DIAGNOSIS AND TREATMENT (U.S. CLS. 26, 39 AND 44).

**CLASS 42—SCIENTIFIC AND COMPUTER SERVICES**

FOR RESEARCH AND DEVELOPMENT OF NEW PRODUCTS IN THE FIELD OF BIOTECHNOLOGY; SERVICES FOR SCIENTIFIC ANALYSIS FOR MEDICAL PURPOSES, NAMELY, MEDICAL RESEARCH LABORATORY SERVICES; DEVELOPMENT OF NEW PRODUCTS FOR MEDICAL RESEARCH FOR THIRD PARTIES (U.S. CLS. 100 AND 101).

SN 79-076,423. CELLPROTHERA, FRANCE, FILED 7-31-2009.

**CellProthera**

PRIORITY DATE OF 2-3-2009 IS CLAIMED.  
OWNER OF INTERNATIONAL REGISTRATION 1022358  
DATED 7-31-2009, EXPIRES 7-31-2019.  
THE MARK CONSISTS OF THE WORDING "CELL-  
PROTHERA" IN A STYLIZED FONT WITH THE LETTER  
"O" REPRESENTED BY A SOLID CIRCLE.

**CLASS 44—MEDICAL, BEAUTY AND AGRICULTURAL SERVICES**

FOR MEDICAL CARE AND TREATMENT; MEDICAL SERVICES FOR CELL SAMPLING AND ISOLATION, NAMELY, LEUKAPHERESIS MEDICAL TREATMENT SERVICES; SERVICES FOR MEDICAL ANALYSIS RELATING TO TREATING INDIVIDUALS, NAMELY, BEHAVIOR ANALYSIS FOR MEDICAL PURPOSES; THERAPEUTIC TREATMENT, NAMELY, CELL THERAPY FOR REGENERATIVE MEDICINE (U.S. CLS. 100 AND 101).

APRIL ROACH, EXAMINING ATTORNEY



SN 79-077,069. NED, FRANCE, FILED 8-6-2009.



OWNER OF INTERNATIONAL REGISTRATION 1024210 DATED 8-6-2009, EXPIRES 8-6-2019.

OWNER OF U.S. REG. NO. 2,286,897.

THE COLOR(S) ORANGE AND BLACK IS/ARE CLAIMED AS A FEATURE OF THE MARK.

THE MARK CONSISTS OF THE WORDING "COP.COPINE" APPEARING IN THE COLOR BLACK FEATURED BELOW THE DESIGN OF A STYLIZED HUMAN CHARACTER APPEARING IN THE COLOR ORANGE COMPRISED OF A CIRCLE APPEARING ABOVE A GEOMETRIC RECTANGULAR SHAPE.

THE ENGLISH TRANSLATION OF "COPINE" IN THE MARK IS "FEMALE FRIEND".

### CLASS 3—COSMETICS AND CLEANING PREPARATIONS

FOR COSMETIC PRODUCTS, NAMELY, AFTER-SUN GELS, COSMETIC PREPARATIONS, PRE-MOISTENED COSMETIC TISSUES; PERFUMERY AND BEAUTY PRODUCTS, NAMELY, BEAUTY GELS, BEAUTY CREAMS FOR BODY CARE, AND FACIAL BEAUTY MASKS; SOAPS, PERFUMES, ESSENTIAL OILS, HAIR LOTIONS; COSMETIC KITS COMPRISED OF LIPSTICK AND LIP GLOSS; BATH SALTS, NOT FOR MEDICAL PURPOSES; SCENTED LINEN WATER; INCENSE STICKS; BLEACHING PREPARATIONS FOR COSMETIC USE; LAUNDERING PREPARATIONS, NAMELY, CLEANING, POLISHING AND ABRASIVE PREPARATIONS, DEGREASING PREPARATIONS, POLISH AND CREAMS FOR THE CARE AND PRESERVATION OF LEATHER (U.S. CLS. 1, 4, 6, 50, 51 AND 52).

### CLASS 9—ELECTRICAL AND SCIENTIFIC APPARATUS

FOR SUNGLASSES, SPORTS GLASSES, OPTICAL GOODS, NAMELY, ANTI-GLARE GLASSES, EYE GLASSES, CORRECTIVE GLASSES, EYEWEAR CASES; MAGNETIC CARDS; BLANK CD-ROMS FOR SOUND OR VIDEO RECORDING; COMPACT DISCS FEATURING MUSIC; SOUND RECORDING DISCS, NAMELY, PRE-RECORDED CDS, VIDEO TAPES, LASER DISKS FEATURING MUSIC; MAGNETIC DATA MEDIA, NAMELY, BLANK HARD COMPUTER DISCS AND BLANK FLOPPY COMPUTER DISCS; MOUSE PADS; MOBILE PHONES (U.S. CLS. 21, 23, 26, 36 AND 38).

### CLASS 14—JEWELRY

FOR JEWELRY AND FASHION JEWELRY PRODUCTS, NAMELY, IMITATION JEWELRY, BROOCHES, BANGLES, RINGS, FINGER RINGS, EARRINGS, BRACELETS, CHAINS, NECKLACES, TIE PINS, MEDALLIONS, JEWELRY, ORNAMENTAL PINS, TIMEPIECES AND CHRONOMETRIC INSTRUMENTS OF PRECIOUS METALS, NAMELY, WATCHES, WRISTWATCHES, WATCH BANDS, WATCH CASES, CHRONOMETERS, AND ALARM CLOCKS (U.S. CLS. 2, 27, 28 AND 50).

### CLASS 18—LEATHER GOODS

FOR LEATHER GOODS, NAMELY, BRIEFCASES, KEY CASES, AND PURSES; HANDBAGS, ALL-PURPOSE CARRYING BAGS, BEACH BAGS, TRAVELLING BAGS, VALISES, TRUNKS, PORTMANTEAUS, ATTACHE CASES, WALLETS, COIN HOLDERS IN THE NATURE OF WALLETS, SUITCASES, TOILETRY BAGS SOLD EMPTY, HANDBAGS, SHOULDER BAGS, DOCUMENT CASES, CARD CASES, NAMELY, BUSINESS CARD CASES, CALLING CARD CASES, AND NAME CARD CASES; LEATHER POUCHES; DOG COLLARS, CLOTHING FOR ANIMALS; KEY CASES; UMBRELLAS, SUNSHADE PARASOLS, CANES; GARMENT BAGS FOR TRAVEL (U.S. CLS. 1, 2, 3, 22 AND 41).

### CLASS 25—CLOTHING

FOR CLOTHING, NAMELY, BOOTS, SOCKS, APRONS, ATHLETIC FOOTWEAR, UNIFORMS, BANDANAS, HEAD BANDS, ROBES, BEACHWEAR, BELTS, BERETS, BERMUDA SHORTS, BLOUSES, BOXER SHORTS AND BRIEFS, COATS, COVERALLS, COVER-UPS, DRESSES, DUNGAREES, FOOTWEAR, GLOVES, NIGHT GOWNS, GYM SHORTS AND SUITS, HALTER TOPS, HATS, HEAD WEAR, HOODS, INFANT WEAR, NAMELY, INFANT CLOTH DIAPERS, SHIRTS, PANTS AND PAJAMAS, JACKETS, JERSEYS, JOGGING SUITS, JUMPERS, JUMP SUITS, KNIT SHIRTS, LINGERIE, LOUNGE WEAR, MINISKIRTS, NECKWEAR, NIGHT SHIRTS, OVERALLS, PYJAMAS, PANTIES, SKI PANTS, SNOW PANTS, SWEAT PANTS, BALLOON PANTS, PARKAS, PLAY SUITS, POLO SHIRTS, PULLOVERS, RAIN WEAR, NAMELY, RAIN COATS, RAIN SUITS, RAIN BOOTS AND RAIN HATS, SANDALS, WARM-UP SUITS, SUN VISORS, SUSPENDERS, SWEAT SHIRTS, SWEAT SHORTS, SWEATERS, SWIM WEAR, T-SHIRTS, TANK TOPS, THONGS, TIGHTS, TROUSERS, TURTLENECK SWEATERS, UNDER CLOTHES, THERMAL UNDERWEAR AND VESTS (U.S. CLS. 22 AND 39).

CHARISMA HAMPTON, EXAMINING ATTORNEY

SN 79-077,070. RADIUS SYSTEMS LIMITED, UNITED KINGDOM, FILED 8-19-2009.



PRIORITY DATE OF 2-20-2009 IS CLAIMED.  
OWNER OF INTERNATIONAL REGISTRATION 1024214 DATED 8-19-2009, EXPIRES 8-19-2019.

THE MARK CONSISTS OF A MAN WITH AN OUTSTRETCHED RIGHT ARM WITH A CIRCLE EMANATING FROM THE MAN'S HAND AND ONLY THREE QUARTERS OF THE CIRCLE REPRESENTED.

**CLASS 6—METAL GOODS**

FOR METALLIC PIPES; METALLIC GUTTERS, METALLIC INSPECTION WELLS AND METAL INSPECTION RINGS NOT INCLUDING METAL SEAL RINGS, ALL USED FOR WATER SUPPLY, SEWERAGE SYSTEMS, GAS SUPPLY, ELECTRICITY SUPPLY, IRRIGATION, DRAINAGE, PLUMBING AND USED TO HOUSE ELECTRICAL CABLES, TELECOMMUNICATION CABLES, OPTICAL CABLES, SIGNALLING CABLES FOR ROADS AND RAILWAYS; PARTS AND FITTINGS FOR ALL THE AFORESAID GOODS, NAMELY, METALLIC PIPE JOINTS, CONNECTORS AND CONNECTOR SLEEVES, PIPE AND GUTTER CONNECTORS, TEES, FLANGES AND END CAPS, ALL MADE OF METAL; PARTS AND FITTINGS FOR ALL THE AFORESAID GOODS, BEING COMPONENTS OF THE AFORESAID GOODS (U.S. CLS. 2, 12, 13, 14, 23, 25 AND 50).

**CLASS 9—ELECTRICAL AND SCIENTIFIC APPARATUS**

FOR PLASTIC CONDUITS FOR ELECTRICAL WIRING (U.S. CLS. 21, 23, 26, 36 AND 38).

**CLASS 11—ENVIRONMENTAL CONTROL APPARATUS**

FOR APPARATUS AND INSTALLATIONS FOR HEATING, WATER SUPPLY AND SANITARY PURPOSES, NAMELY, UNDER FLOOR HEATING AND AIR COOLING INSTALLATIONS, SOLAR WATER HEATING SYSTEMS COMPRISED OF SOLAR COLLECTORS AND SOLAR WATER HEATERS, GROUND SOURCE HEAT PUMP INSTALLATIONS COMPRISED OF HEAT PUMPS, BORE HOLE WATER EXTRACTION INSTALLATIONS COMPRISED OF PRESSURE REGULATORS FOR WATER INSTALLATIONS; PARTS AND FITTINGS FOR ALL THE AFORESAID GOODS, BEING COMPONENTS OF THE AFORESAID GOODS (U.S. CLS. 13, 21, 23, 31 AND 34).

**CLASS 17—RUBBER GOODS**

FOR FLEXIBLE PLASTIC PIPES AND TUBES USED FOR WATER SUPPLY, SEWERAGE SYSTEMS, GAS SUPPLY, ELECTRICITY SUPPLY, IRRIGATION, DRAINAGE, PLUMBING AND USED TO HOUSE ELECTRICAL CABLES, TELECOMMUNICATION CABLES, OPTICAL CABLES, SIGNALLING CABLES FOR ROADS AND RAILWAYS; NON-METAL PIPE JOINTS, CONNECTORS AND CONNECTOR SLEEVES USED TO JOIN PIPES, TUBES AND CONDUITS AND USED IN WATER SUPPLY, SEWERAGE SYSTEMS, GAS SUPPLY, IRRIGATION, DRAINAGE, PLUMBING; PARTS AND FITTINGS FOR ALL THE AFORESAID GOODS, NAMELY, PIPE CONNECTORS, TEES FOR JOINING PIPES, FLANGES AND END CAPS ALL MADE OF PLASTIC FOR FLEXIBLE PIPES; PLASTIC CONDUITS FOR PLUMBING USE; PLASTIC DUCTS USED FOR WATER SUPPLY, SEWERAGE SYSTEMS, GAS SUPPLY, IRRIGATION, DRAINAGE AND PLUMBING; PARTS AND FITTINGS FOR ALL THE AFORESAID GOODS, BEING COMPONENTS OF THE AFORESAID GOODS (U.S. CLS. 1, 5, 12, 13, 35 AND 50).

**CLASS 19—NON-METALLIC BUILDING MATERIALS**

FOR RIGID NON-METALLIC PIPES, TUBES AND CONDUITS AND PIPES, TUBES AND CONDUITS MADE FROM COMPOSITE MATERIALS, NAMELY, HYBRID PIPES MADE FROM METAL AND PLASTIC MADE IN SUBSTANTIAL PART OF NON-METAL MATERIAL, ALL USED FOR WATER SUPPLY, SEWERAGE SYSTEMS, GAS SUPPLY, ELECTRICITY SUPPLY, IRRIGATION, DRAINAGE, PLUMBING AND USED TO HOUSE ELECTRICAL CABLES, TELECOMMUNICATION CABLES, OPTICAL CABLES, SIGNALLING CABLES FOR ROADS AND RAILWAYS; CHAMBERS IN THE NATURE OF NON-METAL STRUCTURES BEING ACCESS POINTS INTO DUCTING TO ALLOW INSPECTION AND ALTERATION OF INFRASTRUCTURE SERVICES RUNNING INSIDE DUCTING AND BOXES, THAT SERVE AS PARTS OF INFRASTRUCTURE TRUNK

SYSTEMS USED FOR SPLICING JOINTS AND ROUTING CABLES/FIBRES AWAY FROM A MAIN TRUNK SYSTEM; NON-METAL GUTTERS; NON-METAL INSPECTION WELLS USED TO CHECK THE CONDITION OF UNDERGROUND PIPES AND UNDERGROUND UTILITY INFRASTRUCTURE, SUCH AS, WATER, SEWAGE, ELECTRICITY, COMMUNICATIONS PIPELINES; ASPHALT, PITCH AND BITUMEN; DRAINAGE INSTALLATIONS, NAMELY, PLASTIC CONDUIT FOR DRAINAGE, CONCRETE DRAINAGE STRUCTURES IN THE FORM OF STORM MANHOLES, PLASTIC DEBRIS TRAP FOR STORM DRAINAGE, AND MOISTURE DRAINAGE SYSTEM CONSISTING OF NON-METAL TROUGHS; PLASTIC CONDUITS FOR DRAINAGE AND IRRIGATION; NON-METAL PIPE JOINTS, NON-METAL CONNECTORS AND NON-METAL CONNECTOR SLEEVES USED TO JOIN RIGID NON-METALLIC PIPES AND USED TO JOIN PIPES MADE OF COMPOSITE MATERIALS, NAMELY, HYBRID PIPES MADE FROM METAL AND PLASTIC MADE IN SUBSTANTIAL PART OF NON-METAL MATERIAL AND USED FOR WATER SUPPLY, SEWERAGE SYSTEMS, GAS SUPPLY, IRRIGATION, DRAINAGE AND PLUMBING; NON-METAL GUTTER CONNECTORS; PIPE CONNECTORS TEES FOR JOINING PIPES, FLANGES AND END CAPS ALL MADE OF PLASTIC FOR RIGID NON-METALLIC PIPES AND USED TO JOIN PIPES MADE OF COMPOSITE MATERIALS, NAMELY, HYBRID PIPES MADE FROM METAL AND PLASTIC MADE IN SUBSTANTIAL PART OF NON-METAL MATERIAL; PARTS AND FITTINGS FOR ALL THE AFORESAID GOODS BEING COMPONENTS OF THE AFORESAID GOODS (U.S. CLS. 1, 12, 33 AND 50).

**CLASS 41—EDUCATION AND ENTERTAINMENT**

FOR EDUCATION SERVICES, NAMELY, THE PROVISION OF CLASSES, SEMINARS, AND CORRESPONDENCE COURSES IN THE FIELD OF PLASTIC PIPING SYSTEMS FOR UTILITY INFRASTRUCTURE APPLICATIONS; PROVISION OF TRAINING, NAMELY, PROVISION OF PRACTICAL COURSES AND EDUCATIONAL DEMONSTRATIONS IN THE FIELD OF PLASTIC PIPING SYSTEMS FOR UTILITY INFRASTRUCTURE APPLICATIONS; EDUCATIONAL SERVICES, NAMELY, PROVISION OF SEMINARS AND WORKSHOPS IN THE FIELD OF PLASTIC PIPING SYSTEMS FOR UTILITY INFRASTRUCTURE APPLICATIONS (U.S. CLS. 100, 101 AND 107).

**CLASS 42—SCIENTIFIC AND COMPUTER SERVICES**

FOR SCIENTIFIC AND TECHNOLOGICAL SERVICES AND RESEARCH AND DESIGN RELATING THERETO, NAMELY, THE DESIGN AND DEVELOPMENT OF PIPES, PIPING SYSTEMS FOR UTILITY INFRASTRUCTURE APPLICATIONS; INDUSTRIAL ANALYSIS AND RESEARCH SERVICES, NAMELY, ANALYZING AND RESEARCHING THE TECHNICAL CHARACTERISTICS OF NEW TYPES OF PIPES, PIPING SYSTEMS FOR UTILITY INFRASTRUCTURE APPLICATIONS; TECHNICAL CONSULTANCY SERVICES, NAMELY, PROVIDING ADVICE TO OTHERS IN THE FIELD OF CIVIL ENGINEERING, SPECIFICALLY PROVIDING ADVICE ON THE DESIGN, DEVELOPMENT AND CONSTRUCTION UTILITY INFRASTRUCTURE SYSTEMS CONSISTING OF PIPES, TUBES AND CONDUITS (U.S. CLS. 100 AND 101).

WILLIAM VERHOSEK, EXAMINING ATTORNEY

SN 79-077,072. BENHAMOU MARCEL, 0162 TBILISSI, REP OF GEORGIA, FILED 8-20-2009.

PRIORITY DATE OF 6-5-2009 IS CLAIMED.  
OWNER OF INTERNATIONAL REGISTRATION 1024216 DATED 8-20-2009, EXPIRES 8-20-2019.  
THE WORDING "DZE" AND "DC", AS USED BY APPLICANT, HAS NO MEANING IN A FOREIGN LANGUAGE.

### CLASS 3—COSMETICS AND CLEANING PREPARATIONS

FOR COSMETIC PRODUCTS, NAMELY, CREAMS, GELS, LOTIONS, WATERS, MILKS, PRE-MOISTENED COSMETIC WIPES FOR THE CARE, UPKEEP, HYDRATION, REFRESHMENT, REVITALISING AND TONING OF THE SKIN; ANTI-WRINKLE CREAMS; EXFOLIANTS FOR THE SKIN; ESSENTIAL OILS; OILS FOR TOILETRY USE; MASSAGE OILS; BEAUTY MASKS; POMADES FOR COSMETIC PURPOSES; COSMETIC BATH PREPARATIONS; COSMETIC SUN-TANNING PREPARATIONS; COSMETIC PRODUCTS IN THE FORM OF AEROSOLS FOR SKIN CARE; COSMETIC SUN-TANNING PREPARATIONS; MAKE-UP REMOVING PRODUCTS, NAMELY, WATERS, LOTIONS, WIPES IMPREGNATED WITH A SKIN CLEANSER, OR GELS FOR MAKE-UP REMOVING, AND MAKE-UP REMOVING MILKS; SHAVING PRODUCTS, NAMELY, SHAVING GELS AND CREAMS, SHAVING SOAPS, AFTER-SHAVE LOTIONS; SKIN FRESHENING PREPARATIONS IN THE FORM OF AEROSOL; TALCUM POWDER FOR TOILETRY USE; BODY AND HAIR HYGIENE PRODUCTS, NAMELY, BATH AND SHOWER GELS AND CREAMS, SOAPS; DEODORANTS FOR PERSONAL USE, SHAMPOOS, HAIR CONDITIONERS, HAIR LOTIONS; PERFUMERY, NAMELY, COLOGNE WATERS; TOILET WATERS; PERFUMES; DEODORANT FOR BODY CARE IN THE FORM OF ALUM STONES; BATH SALTS, NOT FOR MEDICAL USE (U.S. CLS. 1, 4, 6, 50, 51 AND 52).

### CLASS 5—PHARMACEUTICALS

FOR DIETETIC BEVERAGES ADAPTED FOR MEDICAL USES; HERBAL MUD FOR BATHS FOR THERAPEUTIC PURPOSES; MEDICINAL PREPARATION FOR USE IN THERMAL THERAPY, NAMELY, MUD PACKS; MINERAL WATERS FOR USE IN TREATING DERMATOLOGY AND SKIN CARE ISSUES; THERMAL WATER FOR USE IN TREATING DERMATOLOGY AND SKIN CARE ISSUES; NUTRITIONAL OILS FOR USE IN TREATING DERMATOLOGY AND SKIN CARE ISSUES; MEDICAL PREPARATIONS FOR SLIMMING USE; BATH SALTS FOR MEDICAL USE; PHARMACEUTICAL PRODUCTS AND PREPARATIONS FOR SKIN CARE, MEDICATED SUNSCREEN PREPARATIONS; THERAPEUTIC MEDICATED BATH PREPARATIONS, IN PARTICULAR PLANT-BASED; MEDICATED BATH PREPARATIONS; AIR FRESHENERS AND AIR PURIFYING PREPARATIONS; BALMS FOR MEDICAL USE, MEDICINAL INFUSIONS, NAMELY, PLANT EXTRACT INFUSIONS FOR MEDICAL PURPOSES; REDUCING TEA FOR MEDICAL USE, HERBAL TEAS FOR MEDICAL PURPOSE; MEDICINAL TONICS FOR THE TREATMENT OF LACK OF ENERGY (U.S. CLS. 6, 18, 44, 46, 51 AND 52).

### CLASS 32—LIGHT BEVERAGES

FOR NON-ALCOHOLIC FRUIT BEVERAGES; SOFT DRINKS; DRINKING WATERS; FLAVOURED WATERS; AERATED WATERS; MINERAL WATERS; SELTZER WATER; TABLE WATERS; SYRUPS FOR BEVERAGES (U.S. CLS. 45, 46 AND 48).

SHAILA SETTLES, EXAMINING ATTORNEY

SN 79-077,293. UMICORE, SOCIÉTÉ ANONYME, BELGIUM, FILED 8-20-2009.

THE MARK CONSISTS OF STANDARD CHARACTERS WITHOUT CLAIM TO ANY PARTICULAR FONT, STYLE, SIZE, OR COLOR.

PRIORITY DATE OF 3-13-2009 IS CLAIMED.  
OWNER OF INTERNATIONAL REGISTRATION 1024836 DATED 8-20-2009, EXPIRES 8-20-2019.

OWNER OF U.S. REG. NO. 2,996,277.

### CLASS 7—MACHINERY

FOR MOTORS AND ENGINES, EXCEPT FOR LAND VEHICLES; MOTOR AND ENGINE EXHAUST SYSTEMS COMPRISED OF PIPES, COLLECTOR AND MUFFLER; AIR FILTERS FOR ENGINES AND ANTI-POLLUTION DEVICES FOR MOTORS AND ENGINES IN THE NATURE OF CATALYZERS FOR CATALYTIC EMISSION CONTROL; PARTS OF MOTORS AND ENGINES, NAMELY, CATALYTIC EXHAUST-GAS CONVERTERS; INDIVIDUAL COMPONENTS OF EMISSION CONTROL SYSTEMS FOR VEHICLES, NAMELY, CATALYTIC CONVERTERS, PARTS OF MOTORS AND ENGINES, NAMELY, EXHAUST GAS FILTERS AND AIR PARTICLE FILTERS (U.S. CLS. 13, 19, 21, 23, 31, 34 AND 35).

### CLASS 11—ENVIRONMENTAL CONTROL APPARATUS

FOR ANTI-DAZZLE DEVICE FOR VEHICLE HEADLIGHTS, NAMELY, VEHICLE REFLECTORS; APPARATUS FOR EXHAUSTING GASES, NAMELY, VENTILATING EXHAUST FANS; APPARATUS FOR FILTERING GASES, NAMELY, APPARATUS AND INSTRUMENTS FOR USE IN THE PURIFICATION AND SEPARATION OF LIQUIDS AND GASES USED IN THE AUTOMOTIVE INDUSTRY AND FILTERS AND FILTERING DEVICES FOR AIR AND GAS CONDITIONING; VEHICLE HEADLIGHTS; AIR CONDITIONING APPARATUS AND INSTALLATIONS (U.S. CLS. 13, 21, 23, 31 AND 34).

TAMARA FRAZIER, EXAMINING ATTORNEY

SN 79-078,142. MUOVITECH AB, BRÄMHULT, SWEDEN, FILED 12-16-2009.

THE MARK CONSISTS OF STANDARD CHARACTERS WITHOUT CLAIM TO ANY PARTICULAR FONT, STYLE, SIZE, OR COLOR.

PRIORITY DATE OF 6-24-2009 IS CLAIMED.  
OWNER OF INTERNATIONAL REGISTRATION 1026935 DATED 12-16-2009, EXPIRES 12-16-2019.

**CLASS 11—ENVIRONMENTAL CONTROL APPARATUS**

FOR HEATING SYSTEMS COMPOSED PRIMARILY OF TUBES AND PIPES THROUGH WHICH COLD TO WARM WATER CIRCULATES (U.S. CLS. 13, 21, 23, 31 AND 34).

**CLASS 17—RUBBER GOODS**

FOR FLEXIBLE TUBES, NOT OF METAL, NAMELY, POLYETHELENE TUBES, NAMELY, PLASTIC TUBES FOR GENERAL INDUSTRIAL USE (U.S. CLS. 1, 5, 12, 13, 35 AND 50).

**CLASS 19—NON-METALLIC BUILDING MATERIALS**

FOR BUILDING MATERIALS, NAMELY, NON-METAL RIGID PIPES AND TUBES, NAMELY, NON-METAL PIPES AND TUBES USED FOR EXTRACTION, STORAGE AND TRANSPORTATION OF HEAT (U.S. CLS. 1, 12, 33 AND 50).

TASNEEM HUSSAIN, EXAMINING ATTORNEY

**CLASS 42—SCIENTIFIC AND COMPUTER SERVICES**

FOR DESIGN AND DEVELOPMENT OF COMPUTERS AND COMPUTER PROGRAMS FROM NUMERICAL CONTROL DEVICES FOR USE WITH MACHINES AND MACHINE TOOLS FOR WORKING WOOD, PLASTIC, GLASS, MARBLE, METAL; TECHNOLOGICAL SERVICES, NAMELY, TECHNOLOGICAL CONSULTATION IN THE TECHNOLOGY FIELD OF MACHINES AND MACHINE TOOLS FOR WORKING WOOD, PLASTIC, GLASS, MARBLE, METAL AND TECHNOLOGICAL RESEARCH AND DESIGN FOR OTHERS RELATING THERETO; INDUSTRIAL ANALYSIS IN THE FIELD OF MACHINES AND MACHINE TOOLS FOR WORKING WOOD, PLASTIC, GLASS, MARBLE, METAL, NAMELY, TESTING, QUALITY CONTROL, PROCESS CONTROL, ANALYSIS AND EVALUATION OF MATERIALS, NAMELY, WOOD, PLASTIC, GLASS, MARBLE, METAL; RESEARCH SERVICES IN THE FIELD OF MACHINES AND MACHINE TOOLS FOR WORKING WOOD, PLASTIC, GLASS, MARBLE, METAL (U.S. CLS. 100 AND 101).

KAELIE KUNG, EXAMINING ATTORNEY

SN 79-078,687. PRIMA ELECTRONICS SPA, ITALY, FILED 11-25-2009.



THE MARK CONSISTS OF STANDARD CHARACTERS WITHOUT CLAIM TO ANY PARTICULAR FONT, STYLE, SIZE, OR COLOR.

PRIORITY DATE OF 11-11-2009 IS CLAIMED.  
OWNER OF INTERNATIONAL REGISTRATION 1028210 DATED 11-25-2009, EXPIRES 11-25-2019.

**CLASS 7—MACHINERY**

FOR MACHINES AND MACHINE TOOLS FOR THE CUTTING AND FORMING OF MATERIALS, NAMELY, FOR WORKING WOOD, PLASTIC, GLASS, MARBLE, METAL; NUMERICALLY CONTROLLED MACHINES AND MACHINE TOOLS USED FOR THE CUTTING AND FORMING OF MATERIALS, NAMELY, FOR WORKING WOOD, PLASTIC, GLASS, MARBLE, METAL (U.S. CLS. 13, 19, 21, 23, 31, 34 AND 35).

**CLASS 9—ELECTRICAL AND SCIENTIFIC APPARATUS**

FOR ELECTRONIC SYSTEMS AND ELECTRONIC APPARATUS, NAMELY, ELECTRONIC SERVO MOTOR CONTROLLERS, AXES CONTROLLERS, SERVO BOARDS, CONTROLLERS OF MACHINE DEVICES, ELECTRONIC INTERFACE EQUIPMENT FOR MACHINE TOOLS TO INPUT OR OUTPUT CNC (COMPUTER NUMERICAL CONTROL) DATA, PLC'S (PROGRAMMABLE LOGIC CONTROLLER), HMI (HUMAN MACHINE INTERFACE), FOR MACHINES AND MACHINE TOOLS FOR WORKING WOOD, PLASTIC, GLASS, MARBLE, METAL; COMPUTER PROGRAMS FOR THE INDUSTRIAL AUTOMATION OF MACHINES AND MACHINE TOOLS FOR WORKING WOOD, PLASTIC, GLASS, MARBLE, METAL; NUMERICAL CONTROL ELECTRONIC SYSTEMS FOR MACHINES AND MACHINE TOOLS FOR WORKING WOOD, PLASTIC, GLASS, MARBLE, METAL (U.S. CLS. 21, 23, 26, 36 AND 38).

SN 79-080,670. LAERDAL MEDICAL AS, NORWAY, FILED 11-18-2009.



THE MARK CONSISTS OF STANDARD CHARACTERS WITHOUT CLAIM TO ANY PARTICULAR FONT, STYLE, SIZE, OR COLOR.

PRIORITY DATE OF 11-12-2009 IS CLAIMED.  
OWNER OF INTERNATIONAL REGISTRATION 1033511 DATED 11-18-2009, EXPIRES 11-18-2019.  
OWNER OF U.S. REG. NOS. 2,580,409, 3,274,778 AND 3,754,931.

**CLASS 9—ELECTRICAL AND SCIENTIFIC APPARATUS**

FOR APPARATUS AND INSTRUMENTS FOR LIFE-SAVING, EDUCATION AND TRAINING, NAMELY, RESUSCITATION MANNEQUINS; PRERECORDED DVDS, CDS, AND MAGNETIC DATA CARRIERS FEATURING DATA IN THE FIELDS OF MEDICAL TREATMENT AND TRAINING; SOFTWARE CONTAINING INSTRUCTIONS FOR MEDICAL TREATMENT AND TRAINING; COMPUTER HARDWARE; RESUSCITATION SIMULATORS IN THE NATURE OF RESUSCITATION MANNEQUINS; PATIENT SIMULATORS CAPABLE OF SIMULATING SOUNDS, SYMPTOMS, MEDICAL CONDITIONS, AND EVENTS, IN THE FORM OF ANIMATED HUMANOID MEDICAL TEACHING MANNEQUINS WITH SIMULATED INJECTION, MONITORING AND ANALYSIS SITES, AND ALSO INCORPORATING SUB-ASSEMBLY SYSTEMS CONSISTING OF ELECTRONICS, PNEUMATICS AND ELECTRO-MECHANICS WHICH CONTAIN COMPUTERIZED PROGRAMS, TRAINING SYSTEMS, DIAGNOSTIC PROCEDURES, ANALYSIS, AND REPORTING FUNCTIONS (U.S. CLS. 21, 23, 26, 36 AND 38).

**CLASS 16—PAPER GOODS AND PRINTED MATTER**

FOR PRINTED INSTRUCTIONAL AND TEACHING MANUALS AND HANDBOOKS FOR INSTRUCTION ON THE USE OF MEDICAL APPARATUS AND INSTRUMENTS, AND FOR INSTRUCTION ON THE USE OF APPARATUS AND INSTRUMENTS USED IN LIFE-SAVING, EDUCATION AND TRAINING SETTINGS (U.S. CLS. 2, 5, 22, 23, 29, 37, 38 AND 50).

**CLASS 41—EDUCATION AND ENTERTAINMENT**

FOR EDUCATIONAL SERVICES, NAMELY, PROVIDING COURSES OF INSTRUCTION REGARDING THE USE OF PATIENT SIMULATORS WHICH SIMULATE SOUNDS, SYMPTOMS, MEDICAL CONDITIONS AND EVENTS, IN THE FORM OF ANIMATED HUMANOID MEDICAL TEACHING MANNEQUINS WITH SIMULATED INJECTION, MONITORING AND ANALYSIS SITES, AND ALSO INCORPORATING SUB-ASSEMBLY SYSTEMS CONSISTING OF ELECTRONICS, PNEUMATICS AND ELECTRO-MECHANICS, AND DISTRIBUTION OF PRINTED REPORTS IN CONNECTION THEREWITH (U.S. CLS. 100, 101 AND 107).

**CLASS 42—SCIENTIFIC AND COMPUTER SERVICES**

FOR SCIENTIFIC RESEARCH AND TECHNOLOGICAL SERVICES IN THE NATURE OF TECHNOLOGICAL CONSULTING IN THE TECHNOLOGY FIELD OF MEDICAL TREATMENT AND TRAINING INSTRUMENTS AND APPARATUS AND PRODUCT RESEARCH AND DESIGN RELATING THERETO; PRODUCT DEVELOPMENT; ALL THE AFOREMENTIONED SERVICES WITHIN THE FIELDS OF MEDICAL TREATMENT AND TRAINING INSTRUMENTS AND APPARATUS (U.S. CLS. 100 AND 101).

**CLASS 44—MEDICAL, BEAUTY AND AGRICULTURAL SERVICES**

FOR PROVIDING MEDICAL INFORMATION, CONSULTANCY AND ADVISORY SERVICES (U.S. CLS. 100 AND 101).  
ANDREA HACK, EXAMINING ATTORNEY

**CLASS 35—ADVERTISING AND BUSINESS**

FOR THE BRINGING TOGETHER, FOR THE BENEFIT OF OTHERS, OF A VARIETY OF GOODS ENABLING CUSTOMER TO CONVENIENTLY VIEW AND PURCHASE THOSE GOODS FROM AN INTERNET WEB SITE SPECIALIZING IN THE FIELD OF TRAVEL AND ACCOMMODATION RENTAL, HOTEL AND/OR RESTAURANT RESERVATIONS, NAMELY, TICKETS, ATTRACTION TICKETS, TOWELS, CLOTHING, FOOTWEAR AND HEADGEAR, TOYS, GAMES AND PUZZLES, TOILETRIES, SOAPS, PERFUMES, ESSENTIAL OILS, COSMETICS, BAGS, SUITCASES, TRUNKS AND OTHER TRAVEL BAGS, CAMERAS, VIDEO CAMERAS, FILM, STORAGE MEDIA, SPORTS EQUIPMENT, BOOKS, BROCHURES, CATALOGUES, MAPS, SUNGLASSES, INCLUDING THE GOODS OF OTHER PROVIDERS; DATABASE MANAGEMENT; ADVERTISING SERVICES; MARKETING, PROMOTIONAL, PUBLICITY, AND PUBLIC RELATIONS SERVICES; DIRECT MARKETING; SALES PROMOTION; COMPILATION OF ADVERTISEMENTS FOR USE AS WEB PAGES; COMPILATION OF TRAVEL AND LEISURE BUSINESS DIRECTORIES FOR PUBLISHING ON THE INTERNET; PROVISION OF SPACE ON WEB SITES FOR ADVERTISING GOODS AND SERVICES; RESEARCH, REVIEW AND ANALYSIS OF MARKETING STRATEGY; COMMUNICATION PROMOTION STRATEGY MARKET SURVEYS; BUSINESS STRATEGY SERVICES; MARKET RESEARCH; ANALYSIS OF MARKET RESEARCH DATA; OPINION POLLING; TRAVEL AND LEISURE MARKET RESEARCH, NAMELY, MARKET TRENDS FORECASTING; MARKETING CONSULTANCY; BUSINESS ADMINISTRATION SERVICES FOR THE PROCESSING OF INTERNET SALES; BUSINESS INFORMATION, ADVICE AND CONSULTATION IN RESPECT OF THE AFORESAID; PROVIDING BUSINESS INFORMATION BY MEANS OF A GLOBAL COMPUTER NETWORK IN RELATION TO THE AFORESAID SERVICES (U.S. CLS. 100, 101 AND 102).

SN 79-080,780. TRAVEL REPUBLIC LIMITED, KINGSTON-UPON THAMES KT2 6NH, UNITED KINGDOM, FILED 2-16-2010.

# Travel Republic

THE MARK CONSISTS OF STANDARD CHARACTERS WITHOUT CLAIM TO ANY PARTICULAR FONT, STYLE, SIZE, OR COLOR.

OWNER OF INTERNATIONAL REGISTRATION 1033825 DATED 2-16-2010, EXPIRES 2-16-2020.

NO CLAIM IS MADE TO THE EXCLUSIVE RIGHT TO USE "TRAVEL", APART FROM THE MARK AS SHOWN.

**CLASS 39—TRANSPORTATION AND STORAGE**

FOR TRAVEL ARRANGEMENT; ORGANIZING AND ARRANGING TRAVEL; ORGANIZING AND ARRANGING BUSINESS AND LEISURE TRAVEL; TOURIST AGENCY, TOURIST OFFICE AND TOURIST GUIDE SERVICE ALL IN THE NATURE OF A TRAVEL BOOKING AGENCY; ESCORTING OF TRAVELLERS; ARRANGING OF TOURS AND EXCURSIONS; TRANSPORT RESERVATION SERVICES; AGENCY SERVICES FOR ARRANGING THE TRANSPORTATION OF TRAVELLERS; TRAVEL AGENCY SERVICES; TRAVEL AGENCY CONSULTANCY; TRAVEL AGENCY AND RESERVATION SERVICES FOR TRAVEL BY AIR, RAIL, ROAD, WATER OR SEA; ARRANGEMENT FOR THE TRANSPORTATION OF PASSENGERS BY AIR, RAIL, ROAD, WATER AND SEA; BOOKING AGENCY SERVICES RELATING TO TRAVEL; BOOKING OF SEATS FOR TRAVEL BY AIR, RAIL, ROAD, WATER AND SEA; PARKING SPACE RENTAL; PACKAGING OF ARTICLES FOR TRANSPORTATION; DELIVERY OF GOODS; PARCEL DELIVERY; FREIGHT BROKERAGE; FREIGHT FORWARDING; INFORMATION SERVICES RELATING TO TRAVEL; COMPUTERIZED INFORMATION SERVICES RELATING TO TRAVEL AND TRAVEL RESERVATIONS; PROVIDING INFORMATION BY MEANS OF GLOBAL COMPUTER NETWORK IN RELATION TO THE AFORESAID SERVICE, NAMELY, TRAVEL AGENCY SERVICE INFORMATION; VEHICLE RENTAL INFORMATION; CONSULTATION IN RELATION TO TRAVEL ARRANGEMENT, TRANSPORT RESERVATION SERVICES PACKAGING OF ARTICLES FOR TRANSPORTATION, DELIVERY OF GOODS, PARCEL DELIVERY, FREIGHT BROKERAGE AND FREIGHT FORWARDING (U.S. CLS. 100 AND 105).

**CLASS 42—SCIENTIFIC AND COMPUTER SERVICES**

FOR TRAVEL AND LEISURE MARKET INFORMATION DATABASE CREATION, NAMELY, DATABASE DESIGN AND DEVELOPMENT AND DATABASE SOFTWARE MAINTENANCE SERVICES FOR OTHERS; COMPUTER DESIGN SERVICES; WEB SITE DESIGN AND DEVELOPMENT SERVICES; CREATING, MAINTAINING AND HOSTING THE WEB SITES OF OTHERS; COMPUTER DESIGN RESEARCH; GRAPHIC DESIGN SERVICES, NAMELY, DESIGN OF BROCHURES, CATALOGUES, MAGAZINES, PUBLICATIONS, PRINTED MATERIAL; DATABASE DEVELOPMENT SERVICES (U.S. CLS. 100 AND 101).

**CLASS 43—HOTEL AND RESTAURANT SERVICES**

FOR PROVISION OF HOTEL AND TEMPORARY ACCOMMODATION; ARRANGING AND RENTAL OF HOLIDAY TEMPORARY ACCOMMODATION; HOTEL RESERVATION SERVICES; TEMPORARY ACCOMMODATION SERVICES RELATING TO VILLAS, APARTMENTS; BOOKING OF TEMPORARY ACCOMMODATION; RESTAURANT, CAFETERIA AND CATERING SERVICES; RESTAURANT RESERVATION SERVICES; BAR SERVICES (U.S. CLS. 100 AND 101).  
WILLIAM ROSSMAN, EXAMINING ATTORNEY

**CLASS 9—ELECTRICAL AND SCIENTIFIC APPARATUS**

FOR TELECOMMUNICATIONS AND DATA PROCESSING APPARATUS AND EQUIPMENT, NAMELY, TELECOMMUNICATION ROUTERS, SWITCHES, MULTIPLEXERS, DEMULTIPLEXERS, GATEWAY HARDWARE, AND SERVERS, LAN (LOCAL AREA NETWORK), MAN (METROPOLITAN AREA NETWORK), WAN (WIDE AREA NETWORK), SAN (STORAGE AREA NETWORK) AND VPN (VIRTUAL PRIVATE NETWORK) HARDWARE AND OPERATING SOFTWARE; COMPUTER SOFTWARE FOR ACCESSING, MANAGING, SECURING, OPERATING AND MONITORING TELECOMMUNICATIONS NETWORKS AND TELEPHONY SYSTEMS; SOFTWARE FOR QUALITY CONTROL AND DETECTION OF DEFAULTS AND INCIDENTS IN TELECOMMUNICATIONS NETWORKS; SOFTWARE FOR FACILITATING ELECTRONIC MAIL; SOFTWARE FOR FACILITATING VOICE MESSAGING; COMPUTER E-COMMERCE SOFTWARE TO ALLOW USERS TO PERFORM ELECTRONIC BUSINESS TRANSACTIONS VIA A GLOBAL COMPUTER NETWORK; SOFTWARE FOR ACCOUNTING AND FOR BILLING TELECOMMUNICATIONS COSTS; SOFTWARE FOR ANALYZING TELECOMMUNICATIONS FLOW, TIME AND COSTS; SOFTWARE FOR MANAGING TELEPHONE DIRECTORIES; SOFTWARE FOR MAINTAINING CONFIDENTIALITY OF COMPUTER COMMUNICATIONS BY USING PERSONAL USER IDENTIFICATIONS, ACCESS CONTROL AND ENCRYPTION; COMPUTERS AND MICROCOMPUTERS, THEIR ELECTRICAL AND ELECTRONIC UNITS AND COMPONENTS BEING PART THEREOF AND COMPUTER AND MICROCOMPUTER PERIPHERAL EQUIPMENT; APPARATUS FOR RECORDING, TRANSMISSION OR REPRODUCTION OF SOUND OR IMAGES; BLANK MAGNETIC AND BLANK OPTICAL DATA MEDIA (U.S. CLS. 21, 23, 26, 36 AND 38).

**CLASS 16—PAPER GOODS AND PRINTED MATTER**

FOR INSTRUCTIONAL AND TEACHING MATERIAL, NAMELY, PRINTED TEACHING MATERIALS IN THE FIELDS OF TELECOMMUNICATIONS AND COMPUTER TECHNOLOGY; PAMPHLETS ABOUT TELECOMMUNICATIONS AND COMPUTER TECHNOLOGY; NEWSPAPERS; BOOKS, MANUALS, PERIODICALS AND REVIEWS, ALL IN THE FIELDS OF TELECOMMUNICATIONS AND COMPUTER TECHNOLOGY (U.S. CLS. 2, 5, 22, 23, 29, 37, 38 AND 50).

**CLASS 35—ADVERTISING AND BUSINESS**

FOR DATA PROCESSING SERVICES USING COMPUTERS; RENTAL OF APPARATUS, EQUIPMENT, MACHINES AND INSTALLATIONS IN CONNECTION WITH THE FIELD OF OFFICE TECHNOLOGY; STATISTICAL ANALYSIS SERVICES IN CONNECTION WITH TELECOMMUNICATIONS FOR BUSINESS PURPOSES; BUSINESS AUDITING SERVICES IN THE FIELD OF TELECOMMUNICATIONS; PROVISION OF QUALIFIED PERSONNEL FOR CARRYING OUT SPECIFIC ASSIGNMENTS RELATING PARTICULARLY TO ENGINEERING, INSTALLATION AND TRAINING IN THE FIELD OF TELECOMMUNICATIONS; COMPUTER FILE MANAGEMENT; ORGANIZATION OF EXHIBITIONS FOR COMMERCIAL OR ADVERTISING PURPOSES (U.S. CLS. 100, 101 AND 102).

**CLASS 37—CONSTRUCTION AND REPAIR**

FOR INSTALLATION, MAINTENANCE AND REPAIR OF TELECOMMUNICATIONS AND DATA PROCESSING APPARATUS AND EQUIPMENT (U.S. CLS. 100, 103 AND 106).

SN 79-081,330. ALCATEL LUCENT, FRANCE, FILED 2-1-2010.

**TRANSFORMING COMMUNICATIONS**

THE MARK CONSISTS OF STANDARD CHARACTERS WITHOUT CLAIM TO ANY PARTICULAR FONT, STYLE, SIZE, OR COLOR.

PRIORITY DATE OF 8-7-2009 IS CLAIMED.  
OWNER OF INTERNATIONAL REGISTRATION 1035416 DATED 2-1-2010, EXPIRES 2-1-2020.

OWNER OF U.S. REG. NO. 3,784,970.  
NO CLAIM IS MADE TO THE EXCLUSIVE RIGHT TO USE "COMMUNICATIONS", APART FROM THE MARK AS SHOWN.

**CLASS 38—COMMUNICATION**

FOR TELECOMMUNICATIONS, NAMELY, ELECTRONIC, ELECTRIC, DIGITAL, AND RADIO TRANSMISSION OF VOICE, DATA, IMAGES, SIGNALS, AND MESSAGES; TRANSMISSION OF INFORMATION AND DATA; COMPUTER AIDED TRANSMISSIONS OF MESSAGES AND IMAGES; COMMUNICATIONS BY COMPUTER TERMINALS; ELECTRONIC MAIL SERVICES; INFORMATION ON TELECOMMUNICATIONS; RENTAL OF ACCESS TIME TO GLOBAL COMPUTER NETWORKS (U.S. CLS. 100, 101 AND 104).

**CLASS 41—EDUCATION AND ENTERTAINMENT**

FOR TRAINING SERVICES, PARTICULARLY IN CONNECTION WITH TELECOMMUNICATIONS; ARRANGING AND CONDUCTING OF TRAINING WORKSHOPS, COLLOQUIUMS, CONFERENCES, CONGRESSES, SEMINARS AND SYMPOSIUMS, PARTICULARLY IN CONNECTION WITH TELECOMMUNICATIONS; ORGANIZATION OF EXHIBITIONS FOR CULTURAL AND EDUCATIONAL PURPOSES (U.S. CLS. 100, 101 AND 107).

**CLASS 42—SCIENTIFIC AND COMPUTER SERVICES**

FOR ENGINEERING SERVICES IN THE FIELDS OF TELECOMMUNICATIONS AND DATA PROCESSING; DESIGN, UPDATING, MAINTENANCE, INSTALLATION AND RENTAL OF SOFTWARE; RENTAL OF DATA PROCESSING APPARATUS AND EQUIPMENT; DESIGN AND HOSTING OF INTERNET SITES (U.S. CLS. 100 AND 101).

MICHELLE DUBOIS, EXAMINING ATTORNEY

SN 79-081,430. ROLIC AG, SWITZERLAND, FILED 3-3-2010.

**ROLICURE PEARL**

THE MARK CONSISTS OF STANDARD CHARACTERS WITHOUT CLAIM TO ANY PARTICULAR FONT, STYLE, SIZE, OR COLOR.

PRIORITY DATE OF 10-21-2009 IS CLAIMED.

OWNER OF INTERNATIONAL REGISTRATION 1035600 DATED 3-3-2010, EXPIRES 3-3-2020.

OWNER OF U.S. REG. NOS. 3,130,125 AND 3,239,981.

**CLASS 16—PAPER GOODS AND PRINTED MATTER**

FOR SHEETS OF PAPER USED FOR SECUREMENT PURPOSES IN PRINTING OF FIDUCIARY DOCUMENTS, NAMELY, FOR USE IN PRINTING BANKNOTES, CHEQUES, MONEY ORDERS, POSTAL STAMPS, TAX STAMPS, BANDEROLES, BANK CERTIFICATES, REVENUE CERTIFICATES, SHARES OF STOCK, SHARE CERTIFICATES, GIFT VOUCHERS, AND IDENTIFICATION DOCUMENTS, NAMELY, PASSPORTS, IDENTIFICATION CARDS, DRIVER LICENSES, SOCIAL SECURITY CARDS, VISAS, BIRTH CERTIFICATES, WORKING PERMITS, RESIDENCE PERMITS, VEHICLE REGISTRATION DOCUMENTS; SHEETS OF PAPER FOR PROTECTING MARKS, NAMELY, SHEETS OF PAPER USED FOR SECUREMENT PURPOSES IN PRINTING AND AFFIXING TRADEMARKS TO GOODS AND THEIR PACKAGES; CARDS OF PLASTIC NOT MAGNETICALLY CODED USED FOR BUSINESS TRANSACTIONS; DECORATIVE AND SECURITY SHEETS OF PLASTIC FOR PACKAGING PURPOSES (U.S. CLS. 2, 5, 22, 23, 29, 37, 38 AND 50).

**CLASS 17—RUBBER GOODS**

FOR SHEETS OF PLASTIC FOR APPLICATION TO A SUBSTRATE, NOT FOR PACKAGING PURPOSES, NAMELY, COVERED AND/OR PLASTICIZED SHEETS OF PLASTIC FOR SECUREMENT APPLICATIONS, PARTICULARLY BANKNOTES, CHEQUES, FUNDS TRANSFERS, BANDEROLES, BANK CERTIFICATES, REVENUE CERTIFICATES, SHARES OF STOCK, SHARE CERTIFICATES, GIFT VOUCHERS, PASSPORTS, IDENTIFICATION CARDS, WORKING PERMITS, VEHICLE REGISTRATION DOCUMENTS; SEMI FINISHED SHEETS OF PLASTIC USED FOR MANUFACTURE OF BANKNOTES, CHEQUES, FUNDS TRANSFERS, BANDEROLES, BANK CERTIFICATES, REVENUE CERTIFICATES, SHARES OF STOCK, SHARE CERTIFICATES, GIFT VOUCHERS, PASSPORTS, IDENTIFICATION CARDS, DRIVER LICENSES, SOCIAL SECURITY CARDS, VISAS, BIRTH CERTIFICATES, WORKING PERMITS, RESIDENCE PERMITS, VEHICLE REGISTRATION DOCUMENTS (U.S. CLS. 1, 5, 12, 13, 35 AND 50).

LEIGH CAROLINE CASE, EXAMINING ATTORNEY

SN 79-081,589. RHODIA OPERATIONS, FRANCE, FILED 3-16-2010.



PRIORITY DATE OF 9-23-2009 IS CLAIMED.

OWNER OF INTERNATIONAL REGISTRATION 1036004 DATED 3-16-2010, EXPIRES 3-16-2020.

NO CLAIM IS MADE TO THE EXCLUSIVE RIGHT TO USE "DESIGN", APART FROM THE MARK AS SHOWN.

THE MARK CONSISTS OF THE WORDING "MMI" APPEARING ABOVE AND TO THE RIGHT OF THE WORDING "CONFIDENTDESIGN", WITH ALL OF THE FOREGOING ENCIRCLED BY A BROKEN OVAL DESIGN WITH THE OPEN OF THE OVAL DESIGN NEAR THE BOTTOM-LEFT OF THE MARK. THE STIPPLING IN THE DRAWING IS FOR SHADING PURPOSES AND IS NOT A FEATURE OF THE MARK.

**CLASS 40—MATERIAL TREATMENT**

FOR TREATMENT OF MATERIALS IN THE NATURE OF PLASTICS, NAMELY, INJECTION MOLDING OF FIBER REINFORCED POLYMERS; PROVIDING MATERIALS TREATMENT INFORMATION, NAMELY, INFORMATION REGARDING THE TREATMENT OF PLASTICS (U.S. CLS. 100, 103 AND 106).

**CLASS 42—SCIENTIFIC AND COMPUTER SERVICES**

FOR SCIENTIFIC AND TECHNOLOGICAL SERVICES AND RESEARCH AND DESIGN SERVICES RELATED THERETO, NAMELY, MECHANICAL ANALYSIS OF PLASTICS; INDUSTRIAL RESEARCH IN THE FIELD OF MECHANICAL ANALYSIS; INDUSTRIAL ANALYSIS, NAMELY, MECHANICAL ANALYSIS OF FIBER REINFORCED POLYMERS; QUALITY CONTROL FOR OTHERS; DATA CONVERSION OF COMPUTER PROGRAMS AND DATA, NOT PHYSICAL CONVERSION; SCIENTIFIC RESEARCH IN THE NATURE OF TECHNICAL PROJECT STUDIES, NAMELY, CONDUCTING OF MECHANICAL STUDIES; APPRAISAL SERVICES IN THE FIELD OF ENGINEERING, NAMELY, CONDUCTING ENGINEERING SURVEYS; MATERIAL TESTING; ENGINEERING SERVICES IN THE FIELDS OF SCIENCE AND TECHNOLOGY (U.S. CLS. 100 AND 101).

KEVIN CORWIN, EXAMINING ATTORNEY

---

SN 79-081,762. OCEANUS OPERATING COMPANY LIMITED, UNITED KINGDOM, FILED 3-29-2010.

# FULLVIEW

THE MARK CONSISTS OF STANDARD CHARACTERS WITHOUT CLAIM TO ANY PARTICULAR FONT, STYLE, SIZE, OR COLOR.

OWNER OF INTERNATIONAL REGISTRATION 1036466 DATED 3-29-2010, EXPIRES 3-29-2020.

## CLASS 9—ELECTRICAL AND SCIENTIFIC APPARATUS

FOR COMPUTER SOFTWARE FOR MANAGING AND PROCESSING ELECTRONIC DATA (U.S. CLS. 21, 23, 26, 36 AND 38).

## CLASS 42—SCIENTIFIC AND COMPUTER SERVICES

FOR COMPUTER PROGRAMMING SERVICES TO TAILOR COMPUTER SOFTWARE FOR MANAGING AND PROCESSING ELECTRONIC DATA TO USERS; COMPUTER SOFTWARE DESIGN, DEVELOPMENT, MAINTENANCE AND INSTALLATION; COMPUTER SYSTEMS ANALYSIS; ALL OF THE AFORESAID RELATING TO COMPUTER SOFTWARE FOR MANAGING AND PROCESSING ELECTRONIC DATA (U.S. CLS. 100 AND 101).

KEVIN CORWIN, EXAMINING ATTORNEY

---

SN 79-081,960. CALEFFI S.P.A., ITALY, FILED 12-18-2009.

# CALEFFI GEO

THE MARK CONSISTS OF STANDARD CHARACTERS WITHOUT CLAIM TO ANY PARTICULAR FONT, STYLE, SIZE, OR COLOR.

PRIORITY DATE OF 12-15-2009 IS CLAIMED.

OWNER OF INTERNATIONAL REGISTRATION 1037006 DATED 12-18-2009, EXPIRES 12-18-2019.

THE WORDING "CALEFFI GEO", "CALEFFI", OR "GEO" HAS NO MEANING IN A FOREIGN LANGUAGE.

## CLASS 6—METAL GOODS

FOR MANIFOLDS IN THE NATURE OF METAL PIPES FOR HEAT PUMPS, DISTRIBUTION MANIFOLDS IN THE NATURE OF METAL PIPES FOR HEAT PUMP SYSTEMS (U.S. CLS. 2, 12, 13, 14, 23, 25 AND 50).

## CLASS 7—MACHINERY

FOR DISTRIBUTION MANIFOLDS, NAMELY, CHARGING MANIFOLDS FOR HEAT PUMP SYSTEMS AND THEIR COMPONENTS (U.S. CLS. 13, 19, 21, 23, 31, 34 AND 35).

## CLASS 11—ENVIRONMENTAL CONTROL APPARATUS

FOR BALANCING VALVES WITH FLOWMETER FOR HEATING AND SANITARY SYSTEMS, ISOLATING AND BALANCING VALVES FOR HYDRAULIC AND SANITARY SYSTEMS, ANTI-FROST PROTECTION APPARATUS IN THE NATURE OF VALVES FOR HEAT PUMPS (U.S. CLS. 13, 21, 23, 31 AND 34).

RAMONA ORTIGA, EXAMINING ATTORNEY

---

SN 79-082,031. FOMAS S.P.A., ITALY, FILED 3-24-2010.

# FOMAS

THE MARK CONSISTS OF STANDARD CHARACTERS WITHOUT CLAIM TO ANY PARTICULAR FONT, STYLE, SIZE, OR COLOR.

OWNER OF INTERNATIONAL REGISTRATION 1037173 DATED 3-24-2010, EXPIRES 3-24-2020.

THE WORDING "FOMAS" HAS NO MEANING IN A FOREIGN LANGUAGE.

## CLASS 6—METAL GOODS

FOR METALLIC CONSTRUCTIONS, NAMELY, METAL FORGINGS AND CASTINGS FOR USE IN THE CUSTOM MANUFACTURE OF HEAVY INDUSTRIAL EQUIPMENT, INCLUDING STEAM TURBINE ROTOR SHAFTS, GAS TURBINE COMPRESSOR ROTOR DISCS AND TURBINE ROTOR DISCS, SHELLS, TUBE SHEETS AND NOZZLES FOR PROCESS REACTORS, HEAVY STEEL COMPONENTS FOR NUCLEAR POWER STATIONS, AND STEEL RINGS FOR BEARINGS AND GEARS IN NUCLEAR REACTORS (U.S. CLS. 2, 12, 13, 14, 23, 25 AND 50).

## CLASS 40—MATERIAL TREATMENT

FOR TREATMENT OF METALLIC MATERIALS; TRANSFORMATION SERVICES OF METALLIC MATERIALS BY STAMPING; TRANSFORMATION SERVICES OF METALLIC MATERIALS BY FORGING TO THE ORDER AND SPECIFICATION OF OTHERS; TRANSFORMATION SERVICES OF METALLIC MATERIALS BY CASTING; TRANSFORMATION SERVICES OF METALLIC MATERIALS BY MOLDING (U.S. CLS. 100, 103 AND 106).

LAURA HAMMEL, EXAMINING ATTORNEY

---

SN 79-082,301. POLYSIUS AG, FED REP GERMANY, FILED 2-23-2010.

# CEMCAT

THE MARK CONSISTS OF STANDARD CHARACTERS WITHOUT CLAIM TO ANY PARTICULAR FONT, STYLE, SIZE, OR COLOR.

PRIORITY DATE OF 8-25-2009 IS CLAIMED.

OWNER OF INTERNATIONAL REGISTRATION 1037926 DATED 2-23-2010, EXPIRES 2-23-2020.



**CLASS 7—MACHINERY**

FOR MACHINES AND MACHINE PARTS FOR THE CEMENT, LIME, GYPSUM, CERAMIC, REFRACTORY, IRON AND STEEL AND CHEMICAL INDUSTRIES, NAMELY, EXHAUST GAS COMBUSTION TREATMENT APPARATUS FOR ENGINES POWERED BY DIESEL, GAS, COAL AND/OR WASTE, EXHAUST GAS CATALYTIC CONVERTERS AND EXHAUST GAS PURIFYING APPARATUS FOR ENGINES POWERED BY DIESEL, GAS, COAL AND/OR WASTE FOR USE ON FACTORY AND PLANT FLUE GAS SYSTEMS, FOR USE ON FLUE GAS CLEANING SYSTEMS FOR CLEANING FACTORY AND PLANT FLUES, AND PARTS THEREFOR (U.S. CLS. 13, 19, 21, 23, 31, 34 AND 35).

**CLASS 9—ELECTRICAL AND SCIENTIFIC APPARATUS**

FOR ELECTRIC AND ELECTRONIC DEVICES AND PARTS THEREFOR, NAMELY, MEASURING APPARATUS FOR TAKING MEASUREMENTS AS TO THE AMOUNT OF EXHAUST GASES OR PURITY OF EXHAUST GASES IN THE FACTORY FLUES, PLANT FLUES, AND MACHINES; ELECTRIC REGULATORS FOR FACTORY AND PLANT FLUES AND MACHINES; APPARATUS AND INSTRUMENTS FOR CONTROLLING ELECTRICITY FOR FACTORY FLUES, PLANT FLUES AND MACHINES, NAMELY, ELECTRIC RESISTORS, CAPACITORS, VOLTAGE METERS, CURRENT SENSORS, TRANSFORMERS, AND DIODES; ELECTRICITY ROUTERS FOR MANAGING AND OPTIMIZING ENERGY LOADS WITHIN THE MACHINES; ELECTRICITY CONDUITS, ELECTRICITY LIMITERS, ELECTRICITY ADAPTERS AND ELECTRICAL WIRES; ELECTRIC MONITORS FOR FACTORY FLUES, PLANT FLUES AND MACHINES; INDICATING AND RECORDING APPARATUS FOR FACTORY FLUES, PLANT FLUES AND MACHINES, NAMELY, SENSORS AND ELECTRONIC DATA RECORDERS FOR SENSING AND RECORDING THE AMOUNT OF EXHAUST GASES IN THE FACTORY FLUES, PLANT FLUES AND MACHINES, ALL FOR THE CEMENT, LIME, GYPSUM, CERAMIC, REFRACTORY, IRON AND STEEL AND CHEMICAL INDUSTRIES (U.S. CLS. 21, 23, 26, 36 AND 38).

**CLASS 11—ENVIRONMENTAL CONTROL APPARATUS**

FOR FURNACES, CALCINERS, PREHEATERS AND COOLERS, ALL FOR USE WITH FACTORY AND PLANT FLUES AND MACHINES THEREFOR, FOR THE CEMENT, LIME, GYPSUM, CERAMIC, REFRACTORY, IRON AND STEEL AND CHEMICAL INDUSTRIES (U.S. CLS. 13, 21, 23, 31 AND 34).

DOMINIC FATHY, EXAMINING ATTORNEY

SN 79-082,411. ITALGENIO S.R.L., ITALY, FILED 3-11-2010.

**ITALGENIO**

PRIORITY DATE OF 11-25-2009 IS CLAIMED.  
OWNER OF INTERNATIONAL REGISTRATION 1038257 DATED 3-11-2010, EXPIRES 3-11-2020.

THE MARK CONSISTS OF THE WORD "ITALGENIO" WRITTEN IN SPECIAL CHARACTERS, WHERE THE LETTERS "I" ARE UPSIDE DOWN AND THE LETTER "O" CONSISTS OF A STYLIZED PRINT EVOCATIVE OF A LETTER "T" INSERTED IN A LETTER "U".

THE WORDING "ITALGENIO" HAS NO MEANING IN A FOREIGN LANGUAGE.

**CLASS 9—ELECTRICAL AND SCIENTIFIC APPARATUS**

FOR ELECTRIC ACCUMULATORS; ELECTRIC BATTERIES; ELECTRIC CABLES; JUNCTION SLEEVES FOR ELECTRIC CABLES; ELECTRIC COILS; ELECTRIC APPARATUS FOR COMMUTATION, NAMELY, SWITCHES AND ROTATING SWITCHES; ELECTRIC CONDUCTORS; ELECTRIC CONNECTIONS; ELECTRIC CONTACTS; ELECTRIC CONVERTERS; ELECTRIC COUPLINGS; ELECTRIC AND ELECTRONIC CONNECTORS, NAMELY, CLAMPS; COVERS FOR ELECTRIC OUTLETS; ELECTRIC CURRENT MONITORS; IDENTIFICATION SHEATHS FOR ELECTRIC WIRES; PLUGS, SOCKETS AND OTHER ELECTRIC CONNECTIONS; ELECTRIC RELAYS; ELECTRIC RESISTANCES; SHEATHS FOR ELECTRIC CABLES; ELECTRIC SWITCHES; ELECTRIC WIRES; ELECTRICITY CONDUITS; ELECTRICAL CONNECTORS; ELECTRICAL INDUCTORS; ELECTRICAL INVERTERS; JUNCTION BOXES FOR ELECTRICITY; ELECTRICAL SWITCHBOXES; ELECTRICAL TRANSFORMERS; ELECTRIC WIRE CONNECTORS; ELECTRIC CONTROL PANELS (U.S. CLS. 21, 23, 26, 36 AND 38).

**CLASS 42—SCIENTIFIC AND COMPUTER SERVICES**

FOR DESIGN AND DEVELOPMENT OF SYSTEMS AND COMPONENTS FOR ELECTRICAL CONNECTIONS (U.S. CLS. 100 AND 101).

BARNEY CHARLON, EXAMINING ATTORNEY

SN 79-082,490. ATTILA BAKONYI-KISS, HUNGARY, FILED 3-8-2010.



PRIORITY DATE OF 2-24-2010 IS CLAIMED.  
OWNER OF INTERNATIONAL REGISTRATION 1038445 DATED 3-8-2010, EXPIRES 3-8-2020.

NO CLAIM IS MADE TO THE EXCLUSIVE RIGHT TO USE "DIET SYSTEM", APART FROM THE MARK AS SHOWN.

THE COLOR(S) MAGENTA, PURPLE, ORANGE AND YELLOW IS/ARE CLAIMED AS A FEATURE OF THE MARK.

THE MARK CONSISTS OF THE LETTERS "A" IN PURPLE, "B" IN ORANGE, AND "C" IN MAGENTA, EACH LETTER CONTAINED IN SWIRLING YELLOW CIRCLES WITH A MAGENTA COLORED CRESCENT APPEARING ON THE LEFT SIDE OF EACH CIRCLE. BELOW THESE FEATURES IS THE WORDING "DIET SYSTEM", "DIET" IN ORANGE AND "SYSTEM" IN MAGENTA, OVER A MAGENTA RANDOM WAVE DESIGN.

**CLASS 25—CLOTHING**

FOR CLOTHING, NAMELY, PANTS, SHORTS, SHIRTS, HATS, CAPS, SHIRTS, T-SHIRTS, CLOTH BIBS, CLOTH HEADBANDS AND VISORS, SWEATERS, JACKETS, RAINCOATS, COATS, WARM-UP SUITS, BATHING SUITS, ROBES, PAJAMAS, UNDERWEAR, SOCKS, SHOES, BOOTS, SLIPPERS, DRESSES, SKIRTS, UNITARDS, LEOTARDS, HOSIERY, SCARVES, VESTS, SPORT JACKETS, PARKAS, BELTS, TIES, SUITS, BLAZERS, GLOVES, SLEEPWEAR, NIGHTGOWNS, LINGERIE (U.S. CLS. 22 AND 39).

**CLASS 29—MEATS AND PROCESSED FOODS**

FOR MEAT, FISH, POULTRY AND GAME; MEAT EXTRACTS; PRESERVED, FROZEN, DRIED AND COOKED FRUITS AND VEGETABLES; JELLIES, JAMS, COMPOTES; EGGS, MILK; MILK PRODUCTS EXCLUDING ICE CREAM, ICE MILK AND FROZEN YOGURT; EDIBLE OILS AND FATS (U.S. CL. 46).

**CLASS 30—STAPLE FOODS**

FOR COFFEE, TEA, COCOA, SUGAR, RICE, TAPIOCA, SAGO, ARTIFICIAL COFFEE; FLOUR; PROCESSED CEREALS, BREAD, PASTRY AND CONFECTIONERY MADE OF SUGAR, EDIBLE ICES; HONEY, TREACLE; YEAST, BAKING-POWDER; SALT, MUSTARD; VINEGAR, SAUCES; SPICES; ICE (U.S. CL. 46).

**CLASS 32—LIGHT BEVERAGES**

FOR BEERS; MINERAL AND AERATED WATERS; NON-ALCOHOLIC DRINKS, NAMELY, SOFT DRINKS, COLAS, ENERGY DRINKS, ISOTONIC DRINKS, CIDER; FRUIT DRINKS AND FRUIT JUICES; SYRUPS FOR MAKING BEVERAGES; PREPARATIONS FOR MAKING BEVERAGES, NAMELY, SOFT DRINKS, COLAS, ENERGY DRINKS AND ISOTONIC DRINKS, FRUIT DRINKS AND FRUIT JUICES (U.S. CLS. 45, 46 AND 48).

**CLASS 35—ADVERTISING AND BUSINESS**

FOR RETAIL AND WHOLESALE STORES AND DISTRIBUTORSHIPS, AND ADVERTISING AGENCIES, ALL IN THE FIELD OF FOODSTUFFS, COSMETIC AND CLEANING PREPARATIONS, STATIONERY, HOUSEHOLD UTENSILS, CLOTHING, BEER, TABLE WATERS, NON-ALCOHOLIC BEVERAGES, ALCOHOLIC BEVERAGES AND TOBACCO PRODUCTS (U.S. CLS. 100, 101 AND 102).

**CLASS 43—HOTEL AND RESTAURANT SERVICES**

FOR SERVICES FOR PROVIDING FOOD AND DRINK, NAMELY, RESTAURANT, BARS, AND CAFE SERVICES; FOOD PREPARATION SERVICES FEATURING FRESH, PROPERLY PROPORTIONED, HEALTHY MEALS MADE TO ORDER FOR HOME DELIVERY; PROVIDING TEMPORARY ACCOMMODATION (U.S. CLS. 100 AND 101).

DAWN HAN, EXAMINING ATTORNEY

SN 79-082,573. VIESTINTÄFABRIKKI VIMMA OY, FINLAND, FILED 4-21-2010.

**RON DE JEREMY**

THE MARK CONSISTS OF STANDARD CHARACTERS WITHOUT CLAIM TO ANY PARTICULAR FONT, STYLE, SIZE, OR COLOR.

PRIORITY DATE OF 10-26-2009 IS CLAIMED.

OWNER OF INTERNATIONAL REGISTRATION 1038738 DATED 4-21-2010, EXPIRES 4-21-2020.

THE NAME "RON JEREMY" IDENTIFIES A LIVING INDIVIDUAL WHOSE CONSENT IS OF RECORD.

**CLASS 25—CLOTHING**

FOR CLOTHING, NAMELY, TOPS, BOTTOMS, SHIRTS, PANTS, SHORTS, UNDERWEAR; FOOTWEAR; HEADGEAR, NAMELY, HATS AND CAPS (U.S. CLS. 22 AND 39).

**CLASS 33—WINES AND SPIRITS**

FOR ALCOHOLIC BEVERAGES, EXCEPT BEER (U.S. CLS. 47 AND 49).

DAVID HOFFMAN, EXAMINING ATTORNEY

SN 79-082,762. MASSIMO OSTI S.P.A., ITALY, FILED 12-21-2009.

**MASSIMO  
OSTI  
ARCHIVE**

PRIORITY DATE OF 7-3-2009 IS CLAIMED.

OWNER OF INTERNATIONAL REGISTRATION 1039334 DATED 12-21-2009, EXPIRES 12-21-2019.

OWNER OF U.S. REG. NO. 3,903,286.

THE NAME "MASSIMO OSTI" DOES NOT IDENTIFY A LIVING INDIVIDUAL.

THE MARK CONSISTS OF A SIGN DEPICTING THE WORDING "MASSIMO OSTI ARCHIVE" IN FANCY CHARACTERS PLACED ON THREE LEVELS, BEING THE PORTION "OSTI" PLACED UNDER THE FIRST THREE LETTERS OF THE PORTION "MASSIMO" AND ABOVE THE FIRST THREE LETTERS OF THE PORTION "ARCHIVE".

THE ENGLISH TRANSLATION OF THE WORDS "MASSIMO OSTI" IN THE MARK IS "MAXIMUM INNKEEPERS".

**CLASS 18—LEATHER GOODS**

FOR KNAPSACKS, RUCKSACKS, BACKPACKS, BRIEFCASES, SCHOOL BAGS, PURSES, POCKET WALLET; SPORTS BAGS NOT SPECIALLY ADAPTED FOR MOUNTAIN-CLIMBING; SACHELS, BOSTON BAGS, HANDBAGS, LUGGAGE, SHOULDER BAGS, BEACH BAGS, CLUTCH BAGS, ALL PURPOSE SPORTS BAGS, ATTACHE CASES, TOTE BAGS, TRAVELING BAGS, BUSINESS CARD CASES, CREDIT CARD CASES; CASES OF LEATHER OR LEATHER BOARD; VANITY CASES SOLD EMPTY, KEY CASES MADE OF LEATHER OR LEATHER BOARD, TRAVELING TRUNKS; TRAVELING SETS IN THE NATURE OF A COMBINATION OF SUITCASES, UNFITTED VANITY CASES, TRAVELLING BAGS, WHEELED SUITCASES AND WHEELED TRAVELLING BAGS; SUITCASES; UMBRELLAS, PARASOLS, WALKING STICKS (U.S. CLS. 1, 2, 3, 22 AND 41).

**CLASS 25—CLOTHING**

FOR BRASSIERES; CORSETS, BEING CLOTHING; SINGLETS, PETTICOATS, NIGHTGOWNS, PAJAMAS, DRESSING GOWNS, PULLOVERS, BATH ROBES, BATHING SUITS; GLOVES AND MUFFS, BEING CLOTHING; CARDIGANS; JERSEYS, BEING CLOTHING; NECKTIES, NECKERCHIEFS, SCARVES, SWEATERS, SOCKS, STOCKINGS, SWEAT-ABSORBENT STOCKINGS, TIGHTS, TROUSERS, LEGGINGS, SKIRTS, JACKETS, JERKINS, SHIRTS, POLO SHIRTS, VESTS, WAISTCOATS, JUMPERS, TRACK SUITS, BLOUSES, JEANS, PANTIES, UNDERPANTS, PANTS, BERMUDA SHORTS, SHORTS, T-SHIRTS, SWEAT-SHIRTS, SUITS AND DRESSES, OVERCOATS, ANORAKS, COATS, RAINCOATS, KIMONOS, OVERALLS, SHAWLS, WINDCHEATERS, MITTENS; FOULARDS, BEING CLOTHING; HOSIERY; SASHES FOR WEAR, BEING CLOTHING; BELTS, BEING CLOTHING; WAISTBANDS, BRACES, SUSPENDERS, SUSPENDER BELTS; LOUNGEWEAR, UNDERWEAR, BEACHWEAR, SLEEPWEAR, HEADWEAR, FOOTWEAR (U.S. CLS. 22 AND 39).

NAPOLÉON SHARMA, EXAMINING ATTORNEY

SN 79-082,787. RODA SRL, ITALY, FILED 12-30-2009.

# RODA

THE MARK CONSISTS OF STANDARD CHARACTERS WITHOUT CLAIM TO ANY PARTICULAR FONT, STYLE, SIZE, OR COLOR.

PRIORITY DATE OF 11-30-2009 IS CLAIMED.

OWNER OF INTERNATIONAL REGISTRATION 1039408 DATED 12-30-2009, EXPIRES 12-30-2019.

THE ENGLISH TRANSLATION OF THE WORD "RODA" IN THE MARK IS "WHEEL".

## CLASS 6—METAL GOODS

FOR PORTABLE METAL BUILDINGS; METAL SHELTER STRUCTURES FOR GARDENS; METAL ARCHES, NAMELY, PRE-FABRICATED METAL ARCHITECTURAL COLUMNS, ARBORS, PERGOLAS PRIMARILY OF METAL AND KIOSKS OF METAL FOR THE GARDENS, NAMELY, OPEN PAVILIONS; METAL FIREPLACE SURROUNDS AND METAL DECORATIVE FIREPLACE FACINGS, METAL CHIMNEY POTS, NAMELY, METAL CHIMINEAS, METAL FENCES IN THE NATURE OF METAL EMBER RETAINER FOR USE ON FIREPLACE GRATES, AND METAL BORDERS IN THE NATURE OF METAL MANTLES FOR FIREPLACES; FLOWER BOXES, NAMELY, METAL PLANTERS AND STRUCTURAL PARTS AND ACCESSORIES FOR THE ABOVE MENTIONED PRODUCTS WITHIN THIS INTERNATIONAL CLASS (U.S. CLS. 2, 12, 13, 14, 23, 25 AND 50).

## CLASS 11—ENVIRONMENTAL CONTROL APPARATUS

FOR TABLE LAMPS, FLOOR LAMPS, DESK LAMPS, CEILING LAMPS, WALL LAMPS, GARDEN LAMPS; ELECTRIC SPACE HEATERS; REFRIGERATORS; VENTILATION HOODS FOR STOVES; WATER SUPPLY APPARATUS, NAMELY, WATER COOLERS; ELECTRIC LAMPS AND SUSPENSIONS FOR LAMPS, NAMELY, FOR UMBRELLAS AND GAZEBOS AND TENSILE STRUCTURES FOR GARDENS ALL SOLD TOGETHER AS A SINGLE UNIT (U.S. CLS. 13, 21, 23, 31 AND 34).

## CLASS 18—LEATHER GOODS

FOR GARDEN PARASOLS FOR PROTECTING AGAINST SUN, WIND AND/OR RAIN (U.S. CLS. 1, 2, 3, 22 AND 41).

## CLASS 19—NON-METALLIC BUILDING MATERIALS

FOR PREFABRICATED NON-METAL BUILDINGS; PREFABRICATED NON METAL STRUCTURES AND TENSILE STRUCTURES FOR GARDENS, NAMELY, PREFABRICATED NON-METAL BUILDINGS FOR GARDENS; NON-METAL SCAFFOLDING, NON-METAL FENCINGS, NON-METAL STORAGE SHEDS, NON-METAL FENCING PANELS, PERGOLAS NOT PRIMARILY OF METAL, NON-METAL ARCHES, NAMELY, PREFABRICATED NON-METAL ARCHITECTURAL COLUMNS, ARBORS, NON-METAL TRELLIS, BEAMS NOT OF METAL, NON-METAL KIOSKS FOR THE GARDENS, NAMELY, OPEN PAVILIONS; NON-METAL FENCES FOR GARDENS, NON-METAL RAILINGS FOR USE AS FENCES IN GARDENS AND STRUCTURAL AND REPLACEMENT PARTS FOR THE ABOVE MENTIONED PRODUCTS WITHIN THIS INTERNATIONAL CLASS; NON-METAL AND NON-PRECIOUS NATURAL STONES AND CEMENT STONES FOR GARDENS, NAMELY, BALUSTRADES, COLUMNS, STATUES, PILLARS AND KIOSKS NOT OF METAL, NAMELY, OPEN PAVILIONS; FIREPLACES NOT OF METAL FOR GARDENS, NAMELY, NON-COMBUSTIBLE FIREPLACE SURROUNDS AND DECORATIVE FIREPLACE FACINGS MADE OF NON-METAL NON-COMBUSTIBLE MATERIALS; PONDS INCORPORATING FOUNTAINS, NAMELY, NON-METAL ARTIFICIAL PONDS INCORPORATING FOUNTAINS SOLD AS A SINGLE INTEGRAL UNIT (U.S. CLS. 1, 12, 33 AND 50).

## CLASS 20—FURNITURE AND ARTICLES NOT OTHERWISE CLASSIFIED

FOR INDOOR AND OUTDOOR FURNITURE, NAMELY, CHAIRS, SEATS, SOFAS, STOOLS, FOOTRESTS, TABLES, DECK CHAIRS, BENCHES FOR GARDENS, BEACH CHAIRS, SMALL BEDS AND ALL ABOVE MENTIONED GOODS MADE USING WOOD, CORK, REED, CANE, WICKER, HORN, BONE, BAMBOO, CLOTH, METAL, AND COMBINATION OF THE ABOVE MENTIONED MATERIALS WITH PLASTIC AND NOT INCLUDED IN OTHER CLASSES; PILLOWS FOR SOFAS AND FOR CHAIRS; MIRRORS AND MIRROR FRAMES; LETTER BOXES NOT OF METAL (U.S. CLS. 2, 13, 22, 25, 32 AND 50).

## CLASS 27—FLOOR COVERINGS

FOR CARPETS, RUGS, MATS AND MATTING, LINOLEUM AND FOR COVERING EXISTING FLOORS; NON-TEXTILE WALL HANGINGS (U.S. CLS. 19, 20, 37, 42 AND 50).

## CLASS 42—SCIENTIFIC AND COMPUTER SERVICES

FOR DESIGN OF SPECIALTY INTERIOR AND EXTERIOR ENVIRONMENT SETTINGS IN THE NATURE OF INTERIOR AND EXTERIOR DESIGN SERVICES INCLUDING SPACE PLANNING, FURNITURE SELECTION, MATERIAL AND SURFACE SELECTION (U.S. CLS. 100 AND 101).

NAPOLEON SHARMA, EXAMINING ATTORNEY

SN 79-082,789. NOBLE ROCK CAPITAL MANAGEMENT LIMITED, UNITED KINGDOM, FILED 12-29-2009.

# VIRTO

THE MARK CONSISTS OF STANDARD CHARACTERS WITHOUT CLAIM TO ANY PARTICULAR FONT, STYLE, SIZE, OR COLOR.

PRIORITY DATE OF 12-17-2009 IS CLAIMED.

OWNER OF INTERNATIONAL REGISTRATION 1039411  
DATED 12-29-2009, EXPIRES 12-29-2019.

SN 79-082,909. MOVENTAS OY, FINLAND, FILED 4-21-2010.

### CLASS 7—MACHINERY

FOR VIBRATORY SCREEN SEPARATORS; ELECTRIC MOTORS FOR VIBRATORY SCREEN SEPARATORS; VIBRATORY FEEDERS FOR FEEDING SAND, GRAVEL, AGGREGATES, STONE, MINERALS, ORE, METAL, COAL, CERAMICS, GLASS, PLASTICS, CHEMICALS, POWDERS, FOODSTUFFS, AGRICULTURAL PRODUCTS, WOOD, RECYCLABLES AND WASTE INTO VIBRATORY SCREEN SEPARATORS; SCREENS FOR VIBRATORY SCREEN SEPARATORS; CONVEYORS FOR CONVEYING SAND, GRAVEL, AGGREGATES, STONE, MINERALS, ORE, METAL, COAL, CERAMICS, GLASS, PLASTICS, CHEMICALS, POWDERS, FOODSTUFFS, AGRICULTURAL PRODUCTS, WOOD, RECYCLABLES AND WASTE TO AND FROM VIBRATORY SCREEN SEPARATORS; VIBRATION AMPLIFIERS (U.S. CLS. 13, 19, 21, 23, 31, 34 AND 35).

### CLASS 9—ELECTRICAL AND SCIENTIFIC APPARATUS

FOR COMPUTERS, COMPUTER HARDWARE AND COMPUTER SOFTWARE AND COMPUTER PROGRAMS FOR USE IN VIBRATING SCREENING MACHINES; MICROCHIPS FOR USE IN VIBRATING SCREENING MACHINES; INTEGRATED CIRCUITS FOR USE IN VIBRATING SCREENING MACHINES; COMPUTER SOFTWARE, PROGRAMS, MICROCHIPS AND INTEGRATED CIRCUITS FOR USE IN OPERATING VIBRATION MACHINES, SCREENING MACHINES AND SIFTING MACHINES AND IN VIBRATION MACHINE SYSTEMS AND INDUSTRIAL SCREENING PROCESSES; PLUG ADAPTORS FOR USE IN VIBRATION MACHINES, SCREENING MACHINES AND SIFTING MACHINES; STRUCTURAL AND REPLACEMENTS PARTS AND FITTINGS FOR ALL THE AFORESAID GOODS WITHIN THIS INTERNATIONAL CLASS (U.S. CLS. 21, 23, 26, 36 AND 38).

### CLASS 37—CONSTRUCTION AND REPAIR

FOR MINING EXTRACTION (U.S. CLS. 100, 103 AND 106).

### CLASS 42—SCIENTIFIC AND COMPUTER SERVICES

FOR ENGINEERING SERVICES; TECHNOLOGICAL SERVICES AND RESEARCH AND DESIGN IN THE FIELD OF MINING EXTRACTION AND INDUSTRIAL SCREENING; INDUSTRIAL RESEARCH SERVICES IN THE FIELD OF MINING EXTRACTION; DESIGN AND DEVELOPMENT OF COMPUTER HARDWARE AND SOFTWARE FOR USE IN THE FIELD OF MINING EXTRACTION AND INDUSTRIAL SCREENING; DEVELOPMENT OF TECHNOLOGY, NAMELY, OF VIBRATING SCREENING MACHINES AND DEVELOPMENT OF COMPUTER SOFTWARE AND PROGRAMS RELATING TO ACCELERATED VIBRATION IN SCREENING, SIFTING AND VIBRATING MACHINES; PROVIDING OF INFORMATION, ADVICE AND CONSULTANCY RELATING TO THE AFORESAID, NAMELY, DEVELOPMENT OF COMPUTER SOFTWARE AND HARDWARE AND COMPUTER SOFTWARE AND PROGRAM CONSULTATION IN RELATION TO ACCELERATED VIBRATION SCREENING, SIFTING AND VIBRATION MACHINES (U.S. CLS. 100 AND 101).

NAPOLEON SHARMA, EXAMINING ATTORNEY

# CMAS

THE MARK CONSISTS OF STANDARD CHARACTERS WITHOUT CLAIM TO ANY PARTICULAR FONT, STYLE, SIZE, OR COLOR.

PRIORITY DATE OF 2-26-2010 IS CLAIMED.  
OWNER OF INTERNATIONAL REGISTRATION 1039728  
DATED 4-21-2010, EXPIRES 4-21-2020.

### CLASS 7—MACHINERY

FOR MECHANICAL POWER TRANSMISSION EQUIPMENT AND PARTS THEREFOR FOR THE ENERGY AND PROCESS INDUSTRIES, NAMELY, GEARS, DRIVES, GEARBOXES, GEAR HOUSINGS, GEAR UNITS, GIRTH RINGS, PRESSES, SHAFTS, CLUTCHES, COUPLERS, GEAR WHEELS, GEAR TRAINS, GEAR CLUSTERS, PINIONS, DIFFERENTIALS, GEAR RACKS, TORQUE LIMITERS, IDLERS, TIGHTENERS, SHEAVES, VARIABLE PITCH SHEAVES, BEARINGS, BEARING SEALS, ADAPTOR BEARINGS, PILLOW BLOCKS, FLANGE BLOCKS, TAKE-UP UNITS, TAKE-UP FRAMES, BUSHINGS, BELTS, FLEXIBLE COUPLINGS, ROLLER CHAIN DRIVES, SPROCKETS, ROLLER CHAINS, PULLEYS, MOTOR BASES, CHAIN TOOLS, KEYS, SET COLLARS, HUBS, KEYSTOCK, SPEED REDUCERS, GEARED SPROCKETS, ELECTRICAL ADJUSTABLE SPEED DRIVES, AC AND DC ELECTRIC MOTORS NOT FOR LAND VEHICLES, CLUTCHES, CLUTCH BRAKES, CLUTCH BRAKE COUPLINGS, ANTI-FRICTION BEARINGS, BEARING SEALS, RUBBER BELTING IN WHICH CORDS ARE EMBEDDED, FLEXIBLE LINK BELTING, SYNCHRONOUS DRIVE BELTS, SPRINGS, PINS, RETAINER RINGS AND WIRE FOR MAINTAINING A UNIFORM AIR GAP IN ELECTROMAGNETIC FRICTION CLUTCHES AND BRAKES, BALL SCREWS, MACHINERY SHAFT COUPLINGS, CONVEYOR PULLEYS, AND LOCKING COLLARS FOR ANTI-FRICTION BEARING UNITS (U.S. CLS. 13, 19, 21, 23, 31, 34 AND 35).

### CLASS 9—ELECTRICAL AND SCIENTIFIC APPARATUS

FOR ELECTRICAL AND ELECTRONIC INSTRUMENTS AND MEASURING, CONTROLLING, MONITORING, AND DISPLAY DEVICES, NAMELY, OPTICAL, ELECTRIC, HYDRAULIC AND PNEUMATIC MEASURING INSTRUMENTS FOR MEASURING TEMPERATURE, VIBRATION, TORQUE, PRESSURE, RPM, AND OIL QUALITIES OF POWER TRANSMISSION EQUIPMENT; INFORMATION INPUT AND OUTPUT DEVICES, NAMELY, DATA TRANSMITTERS; COMPUTER CENTRAL PROCESSING UNITS, CABLES FOR DATA TRANSFER, ELECTRONIC SENSORS, COMPUTERS AND COMPUTER SOFTWARE FOR MONITORING, REGULATING AND CONTROLLING OPERATING PARAMETERS OF POWER TRANSMISSION EQUIPMENT (U.S. CLS. 21, 23, 26, 36 AND 38).

### CLASS 37—CONSTRUCTION AND REPAIR

FOR REPAIR AND INSTALLATION OF MECHANICAL POWER TRANSMISSION DEVICES AND EQUIPMENT AND THEIR PARTS (U.S. CLS. 100, 103 AND 106).

### CLASS 42—SCIENTIFIC AND COMPUTER SERVICES

FOR ENGINEERING SERVICES, NAMELY, ANALYZING TECHNICAL DATA RECEIVED FROM POWER TRANSMISSION EQUIPMENT FOR MONITORING, MANAGING AND SUPERVISING EQUIPMENT CONDITION, AND FOR CONTROLLING AND ADJUSTING MECHANICAL GEAR UNITS (U.S. CLS. 100 AND 101).

DAVID HOFFMAN, EXAMINING ATTORNEY

SN 79-082,941. CHARLES MOUYAT, AUSTRALIA, AND LARA VAN DER WALL, AUSTRALIA, FILED 4-7-2010.



OWNER OF INTERNATIONAL REGISTRATION 1039803 DATED 4-7-2010, EXPIRES 4-7-2020.

THE MARK CONSISTS OF THE WORD "ARTMAKER" WHERE THE FIRST LETTER A IS STYLIZED IN A BRUSH STROKE FASHION.

#### CLASS 2—PAINTS

FOR PAINTS FOR ARTISTS (U.S. CLS. 6, 11 AND 16).

#### CLASS 9—ELECTRICAL AND SCIENTIFIC APPARATUS

FOR PRE-RECORDED DVDS FEATURING FILMS BEARING RECORDED EDUCATIONAL MATERIAL IN THE FIELD OF ART (U.S. CLS. 21, 23, 26, 36 AND 38).

#### CLASS 16—PAPER GOODS AND PRINTED MATTER

FOR ARTISTS' BOARDS, NAMELY, FOR DRAWING; ARTISTS' BRUSHES; ARTISTS' CANVAS FOR PAINTING; ARTISTS' CHARCOAL STICKS AND PENCILS; ARTISTS' EASELS; ARTISTS' MODELLING MATERIALS, NAMELY, CLAY; ARTISTS' PAINT BRUSHES; ARTISTS' PALETTES FOR PAINTING; ARTISTS' PAPERS FOR DRAWING, PAINTING AND PRINTING; ARTISTS' PENCILS SOLD IN TINS AND BOXES; ARTISTS' SAUCERS FOR PAINTING; ARTISTS' SKETCH BOOKS; ARTISTS' SPONGES FOR PAINT APPLICATION; ARTISTS' PAINT TRAYS; ARTISTS' WATERCOLOUR SAUCERS; CHALKS FOR ARTISTS' USE; EASELS FOR MOUNTING MATERIALS IN PREPARATION FOR ARTISTS' USE; EASELS FOR SUPPORTING MATERIALS IN PREPARATION FOR USE BY ARTISTS; EASELS FOR USE BY ARTISTS; LINOLEUM BLOCKS FOR ARTISTS FOR PRINTMAKING; MODELLING MATERIALS FOR ARTISTIC USE, NAMELY, CERAMICS AND SCULPTURE; PENCILS FOR ARTISTS; STRETCHERS BEING ARTISTS' MATERIALS, NAMELY, FOR STRETCHING CANVAS FRAMES; WATERCOLOUR SAUCERS FOR ARTISTS; TEACHING MATERIALS FOR EDUCATION, NAMELY, PRINTED INSTRUCTIONS, PRINTED ACTIVITIES SHEETS, PRINTED REFERENCE INFORMATION IN THE FORM OF BOOKS, REPORTS, AND PRINTED SHEETS, AND POSTERS FOR USE IN TEACHING IN THE FIELD OF ART EDUCATION (U.S. CLS. 2, 5, 22, 23, 29, 37, 38 AND 50).

#### CLASS 41—EDUCATION AND ENTERTAINMENT

FOR ADULT EDUCATION, NAMELY, TUTORIALS, ACTIVITIES AND WORKSHOPS IN THE FIELD OF ART; ARRANGING OF EXHIBITIONS FOR EDUCATIONAL PURPOSES IN THE FIELD OF ART; CONDUCTING OF EXHIBITIONS FOR EDUCATIONAL PURPOSES IN THE FIELD OF ART; EDUCATIONAL INSTRUCTION, NAMELY, ART EDUCATION; EDUCATIONAL SERVICES, NAMELY, ART EDUCATION SERVICES; ORGANIZATION OF EXHIBITIONS FOR CULTURAL AND EDUCATIONAL PURPOSES IN THE FIELD OF ART; PROVISION OF EDUCATIONAL COURSES IN THE FIELD OF ART; PROVISION OF EDUCATIONAL INFORMATION IN THE FORM OF TUTORIALS, ACTIVITIES AND WORKSHOPS IN THE FIELD OF ART; PUBLICATION OF EDUCATIONAL MATERIALS; PUBLICATION OF EDUCATIONAL TEXTS (U.S. CLS. 100, 101 AND 107).

FRANK LATTUCA, EXAMINING ATTORNEY

SN 79-082,997. ALEXANDRA GABNER, FED REP GERMANY, FILED 3-16-2010.

# Polesports

THE MARK CONSISTS OF STANDARD CHARACTERS WITHOUT CLAIM TO ANY PARTICULAR FONT, STYLE, SIZE, OR COLOR.

OWNER OF INTERNATIONAL REGISTRATION 1039918 DATED 3-16-2010, EXPIRES 3-16-2020.

#### CLASS 16—PAPER GOODS AND PRINTED MATTER

FOR PRINTED MATTER, NAMELY, PAPER SIGNS, BOOKS, BOOKLETS, PAMPHLETS, LEAFLETS, FLYERS, CALENDARS, MAGAZINES, MANUALS, CURRICULA, NEWSLETTERS, NEWSPAPERS, PHOTOGRAPHS, POSTERS, POSTCARDS, GREETING CARDS, STICKERS, PAPER PATCHES, TICKETS, INFORMATIONAL CARDS, LEARNING CARDS, ACTIVITY CARDS, BROCHURES, PRINTED PERIODICALS, PRINTED HOLOGRAMS, PRINTED VINYL STATIC CLING SHEETS, AND PRINTED PUZZLES IN THE FIELD OF POLE DANCE; PRINTED EDUCATIONAL MATERIALS IN THE FIELD OF POLE DANCE; PRINTED TEACHING MATERIALS IN THE FIELD OF POLE DANCE (U.S. CLS. 2, 5, 22, 23, 29, 37, 38 AND 50).

#### CLASS 41—EDUCATION AND ENTERTAINMENT

FOR ENTERTAINMENT SERVICES, NAMELY, ORGANIZING, ARRANGING, CONDUCTING AND PARTICIPATING IN POLE DANCE EVENTS AND COMPETITIONS; EDUCATIONAL SERVICES, NAMELY, PROVIDING CLASSES, SEMINARS, WORKSHOPS, TUTORING, AND MENTORING IN THE FIELD OF POLE DANCE (U.S. CLS. 100, 101 AND 107).

RAUL CORDOVA, EXAMINING ATTORNEY

SN 79-083,000. CHEMISCHE BOUWSTOFFEN TILLMAN B.V., NETHERLANDS, FILED 4-22-2010.



PRIORITY DATE OF 12-18-2009 IS CLAIMED.  
OWNER OF INTERNATIONAL REGISTRATION 1039922  
DATED 4-22-2010, EXPIRES 4-22-2020.

#### **CLASS 1—CHEMICALS**

FOR CHEMICALS USED IN BUILDING MATERIALS INDUSTRY; ADHESIVES USED IN INDUSTRY (U.S. CLS. 1, 5, 6, 10, 26 AND 46).

#### **CLASS 19—NON-METALLIC BUILDING MATERIALS**

FOR BINDING AGENTS FOR CONCRETE AND MORTAR (U.S. CLS. 1, 12, 33 AND 50).  
FLORENTINA BLANDU, EXAMINING ATTORNEY

---

SN 79-083,057. INSTITUT NATIONAL DE LA RECHERCHE AGRONOMIQUE, PARIS, FRANCE, FILED 4-28-2010.

# **AGREENIUM**

THE MARK CONSISTS OF STANDARD CHARACTERS WITHOUT CLAIM TO ANY PARTICULAR FONT, STYLE, SIZE, OR COLOR.

PRIORITY DATE OF 10-28-2009 IS CLAIMED.  
OWNER OF INTERNATIONAL REGISTRATION 1040095  
DATED 4-28-2010, EXPIRES 4-28-2020.

THE WORDING "AGREENIUM" HAS NO MEANING IN A FOREIGN LANGUAGE.

#### **CLASS 41—EDUCATION AND ENTERTAINMENT**

FOR EDUCATION SERVICES, NAMELY, PROVIDING CLASSES, SEMINARS, WORKSHOPS, TUTORING, IN THE FIELD OF AGRONOMIC SCIENCES, FARMING ACTIVITIES, ANIMAL BREEDING, IRRIGATION AND SOIL FERTILIZING, AFFORESTATION, VETERINARY SCIENCES, GARDENING; PROVIDING OF TRAINING SERVICES IN THE FIELD OF AGRONOMIC AND VETERINARY SCIENCES, ENVIRONMENTAL PROTECTION, FOOD AND NUTRITION RESEARCH; ARRANGING AND CONDUCTING OF COLLOQUIUMS, CONFERENCES AND CONGRESSES IN THE FIELD OF AGRONOMIC AND VETERINARY RESEARCH, FARMING ACTIVITIES, ANIMAL BREEDING, ENVIRONMENTAL PROTECTION, FOOD AND NUTRITION; PROVIDING NON-DOWNLOADABLE ONLINE ELECTRONIC PUBLICATIONS IN THE NATURE OF E-ZINE AND NEWSLETTER IN THE FIELD OF AGRONOMIC AND VETERINARY RESEARCH, FARMING ACTIVITIES, ANIMAL BREEDING, ENVIRONMENTAL PROTECTION, FOOD AND NUTRITION, WATER MANAGEMENT, ANIMAL HEALTH; ORGANIZATION OF EXHIBITIONS FOR CULTURAL OR EDUCATIONAL PURPOSES; PUBLICATION OF BOOKS, MAGAZINES AND NEWSPAPERS, ELECTRONIC DESKTOP PUBLISHING FOR OTHERS; ELECTRONIC PUBLICATION OF BOOKS AND PERIODICALS ONLINE; FILM PRODUCTION; ENTERTAINMENT SERVICES, NAMELY, PROVIDING AN ON-GOING TELEVISION AND RADIO PROGRAM IN THE FIELD OF ENVIRONMENTAL PROTECTION, FOOD AND NUTRITION, ANIMAL BREEDING, FARMING ACTIVITIES, AGRONOMIC AND VETERINARY RESEARCH; PROVIDING INFORMATION ABOUT ONLINE HIGHER EDUCATION RESOURCES AND TEACHING; EDUCATIONAL SERVICES, NAMELY, CONDUCTING DISTANCE LEARNING INSTRUCTION AT THE GRADUATE AND UNIVERSITY LEVEL VIA ANY TELECOMMUNICATION MEDIA OR VIA A COMPUTER NETWORK (U.S. CLS. 100, 101 AND 107).

#### **CLASS 42—SCIENTIFIC AND COMPUTER SERVICES**

FOR BIOLOGICAL, VETERINARY AND AGRONOMIC RESEARCH; INDUSTRIAL ANALYSIS AND RESEARCH SERVICES IN THE FIELDS OF AGRICULTURE, ANIMAL BREEDING, ENVIRONMENTAL PROTECTION, FOOD AND NUTRITION; TECHNICAL PROJECTS STUDIES IN THE FIELDS OF AGRICULTURE, ANIMAL BREEDING, ENVIRONMENTAL PROTECTION, FOOD AND NUTRITION; PROVIDING INFORMATION ON SCIENTIFIC RESEARCH; DESIGN AND DEVELOPMENT OF COMPUTER HARDWARE AND SOFTWARE; VALUATIONS, ESTIMATE AND SCIENTIFIC AND TECHNOLOGICAL INVESTIGATIONS IN THE FIELDS OF FARMING ACTIVITIES, ENVIRONMENTAL PROTECTION, FOOD AND NUTRITION PROVIDED BY ENGINEERS, RESEARCHERS OR TEACHERS; RESEARCH AND DEVELOPMENT OF NEW PRODUCTS FOR OTHERS (U.S. CLS. 100 AND 101).

#### **CLASS 44—MEDICAL, BEAUTY AND AGRICULTURAL SERVICES**

FOR VETERINARY SERVICES AND ANIMAL CARE, NAMELY, ANIMAL HUSBANDRY AND ANIMAL GROWING; AGRICULTURE SERVICES, NAMELY, ADVISORY SERVICES IN THE FIELDS OF IRRIGATION AND FERTILIZATION, AGRONOMIC CONSULTING SERVICES, CONDUCTING SURVEYS OF FARMING ACTIVITIES AND CONSULTATION IN CONNECTION THEREWITH, NUTRITION COUNSELING FOR FARM ANIMALS, PROVIDING A WEBSITE FEATURING INFORMATION AND COUNSELS IN THE FIELDS OF FARMING ACTIVITIES, ENVIRONMENTAL PROTECTION, GRAPE GROWING AND CULTIVATION OF GRAPES, ANIMAL BREEDING, IRRIGATION AND FERTILIZATION, PROVIDING AN ON-LINE DATABASE FEATURING INFORMATION REGARDING PLANT AND SEED COLLECTION FOR AGRICULTURAL PURPOSES; AGRICULTURE SERVICES, NAMELY, PLANTING, GROWING, FERTILIZING PLANTS, VEGETABLES AND FRUIT TREES; AGRICULTURE SERVICES, NAMELY, TECHNICAL CONSULTATION IN

THE FIELDS OF FEEDING AND RAISING FISH, SHRIMPS AND OTHER FARM-RAISED MARINE LIFE; HORTICULTURE SERVICES, NAMELY, PLANTING, GROWING AND FERTILIZING ORNAMENTAL TREES AND FLOWERS, CONSULTING SERVICES FOR CULTIVATION OF ORNAMENTAL TREES AND FLOWERS, GARDENING; FORESTRY SERVICES, NAMELY, FORESTRY MANAGEMENT SERVICES, PROVIDING A WEBSITE FEATURING INFORMATION AND COUNSELS ON FORESTRY MANAGEMENT, AFFORESTATION AND FOREST HABITAT RESTORATION; ANIMAL BREEDING; VERMIN EXTERMINATING FOR AGRICULTURE, HORTICULTURE AND FORESTRY; WEED KILLING; SERVICES PROVIDED BY LANDSCAPE GARDENERS AND NURSERY GARDENERS (U.S. CLS. 100 AND 101).

WARREN L. OLANDRIA, EXAMINING ATTORNEY

SN 79-083,242. NAOMARQ, FRANCE, AND ALCEN, FRANCE, FILED 3-31-2010.

**naomarq**

OWNER OF INTERNATIONAL REGISTRATION 1040647 DATED 3-31-2010, EXPIRES 3-31-2020.

THE WORDING "NAOMARQ" HAS NO MEANING IN A FOREIGN LANGUAGE.

#### CLASS 9—ELECTRICAL AND SCIENTIFIC APPARATUS

FOR SCIENTIFIC APPARATUS AND INSTRUMENTS FOR TRACING, DETECTING, DECODING AND MONITORING, NAMELY, NANOPARTICLE SENSORS AND READERS (U.S. CLS. 21, 23, 26, 36 AND 38).

#### CLASS 42—SCIENTIFIC AND COMPUTER SERVICES

FOR TECHNICAL PROJECT STUDIES, NAMELY, DESIGN OF SYSTEMS FOR TRACING, DETECTING, DECODING AND MONITORING THE AUTHENTICATION OF PRODUCTS TO PREVENT FORGERY AND REPRODUCTION (U.S. CLS. 100 AND 101).

BERNICE MIDDLETON, EXAMINING ATTORNEY

SN 79-083,256. SCARPARI PAOLO, I-30174 VENEZIA, ITALY, FILED 1-20-2010.

 prosperitynet

PRIORITY DATE OF 10-21-2009 IS CLAIMED. OWNER OF INTERNATIONAL REGISTRATION 1040674 DATED 1-20-2010, EXPIRES 1-20-2020.

THE MARK CONSISTS OF THE WORDING "PROSPERITYNET" TO THE RIGHT OF A DESIGN OF TWO INCOMPLETE INTERSECTING OVALS.

#### CLASS 9—ELECTRICAL AND SCIENTIFIC APPARATUS

FOR DOWNLOADABLE AUDIO AND VIDEO FILES FEATURING MENTAL TRAINING AND PERSONAL SELF-IMPROVEMENT, EXCLUDING REAL ESTATE AND REAL ESTATE INVESTING FOR TEACHING PURPOSES; DOWNLOADABLE ELECTRONIC PUBLICATIONS IN THE NATURE OF BOOKS, BOOKLETS, DIARIES, NEWSLETTERS, MAGAZINES, MANUALS FOR USE BY TEACHERS AND PROFESSIONALS IN THE FIELDS OF MENTAL TRAINING AND PERSONAL SELF-IMPROVEMENT, EXCLUDING REAL ESTATE AND REAL ESTATE INVESTING (U.S. CLS. 21, 23, 26, 36 AND 38).

#### CLASS 41—EDUCATION AND ENTERTAINMENT

FOR ARRANGING AND CONDUCTING OF EDUCATIONAL COURSES RELATING TO EDUCATION IN THE FIELDS OF MENTAL TRAINING AND PERSONAL SELF-IMPROVEMENT EXCLUDING REAL ESTATE AND REAL ESTATE INVESTING, PROFESSIONAL TRAINING IN THE FIELDS OF MENTAL TRAINING AND PERSONAL SELF-IMPROVEMENT EXCLUDING REAL ESTATE AND REAL ESTATE INVESTING, AND BUSINESS TRAINING AND BUSINESS MANAGEMENT TRAINING EXCLUDING REAL ESTATE AND REAL ESTATE INVESTING, IN CLASSROOMS AS WELL AS THROUGH WEB PLATFORMS USING THE INTERNET; EDUCATIONAL SERVICES, NAMELY, PROVIDING TRAINING AND EDUCATIONAL INSTRUCTION AND DISTRIBUTION OF TRAINING MATERIAL IN CONNECTION THEREWITH IN THE FIELDS OF MENTAL TRAINING AND PERSONAL DEVELOPMENT EXCLUDING REAL ESTATE AND REAL ESTATE INVESTING; PERSONAL COACHING SERVICES IN THE FIELD OF BUSINESS EXCLUDING REAL ESTATE AND REAL ESTATE INVESTING; PERSONAL COACHING SERVICES IN THE FIELD OF PERSONAL DEVELOPMENT; EDUCATIONAL SERVICES, NAMELY, OFFERING AND LEADING COURSES, SEMINARS, WORKSHOPS AND CLASSES ON PERSONAL IMPROVEMENT COMMUNICATIONS, ON PERSONAL AWARENESS, ON NEGOTIATING SKILLS, ON CRITICAL THINKING AND ON IMPROVEMENT OF RELATIONS AND BEHAVIOR IN INDIVIDUALS AND GROUPS NONE OF THE FOREGOING IN THE FIELDS OF REAL ESTATE OR REAL ESTATE INVESTING; EDUCATIONAL SERVICES, NAMELY, OFFERING AND LEADING COURSES, SEMINARS, WORKSHOPS AND CLASSES ON WEALTH PROCESS AND POTENTIAL GROWTH AND ON BUSINESS TOPICS, EXCLUDING REAL ESTATE AND REAL ESTATE INVESTING IN INDIVIDUALS AND GROUPS; TRAINING IN THE FIELD OF PSYCHOLOGY; BUSINESS COACHING AND BUSINESS DEVELOPMENT EDUCATION SERVICES, NAMELY, WORKSHOPS, SEMINARS, ONLINE LEARNING PROGRAMS, PRIVATE BUSINESS COACHING AND BUSINESS DEVELOPMENT TRAINING SERVICES, EXCLUDING REAL ESTATE AND REAL ESTATE INVESTING (U.S. CLS. 100, 101 AND 107).

HAI-LY LAM, EXAMINING ATTORNEY

SN 79-083,372. VTC CO PTY LTD, AUSTRALIA, FILED 4-27-2010.

 MARKET ANALYST  
Advanced Tools for Advanced Traders

PRIORITY DATE OF 10-29-2009 IS CLAIMED. OWNER OF INTERNATIONAL REGISTRATION 1040957 DATED 4-27-2010, EXPIRES 4-27-2020.

NO CLAIM IS MADE TO THE EXCLUSIVE RIGHT TO USE "MARKET ANALYST", APART FROM THE MARK AS SHOWN.

THE MARK CONSISTS OF THE WORDS "MARKET ANALYST ADVANCED TOOLS FOR ADVANCED TRADERS" NEXT TO A DIAMOND SHAPE CONTAINING INTERSECTING LINES.

#### **CLASS 9—ELECTRICAL AND SCIENTIFIC APPARATUS**

FOR SOFTWARE AND PROGRAMS FOR ANALYSIS OF SHARES, STOCKS, FUTURES, CURRENCIES AND OTHER SECURITIES; SOFTWARE FOR TRADING SHARES, STOCKS, FUTURES, CURRENCIES AND OTHER SECURITIES; SOFTWARE FOR ASSESSING AND EVALUATING TRADING DATA (U.S. CLS. 21, 23, 26, 36 AND 38).

#### **CLASS 36—INSURANCE AND FINANCIAL**

FOR FINANCIAL AND MONETARY SERVICES, NAMELY, FINANCIAL INFORMATION, MANAGEMENT AND ANALYSIS SERVICES; BROKERAGE SERVICES IN THE FIELD OF SHARES, STOCKS, FUTURES, CURRENCIES AND OTHER SECURITIES; PROVIDING OF FINANCIAL ANALYSIS AND ADVICE; INVESTMENT SERVICES, NAMELY, CAPITAL INVESTMENT SERVICES; FINANCIAL CONSULTANCY AND ADVISORY SERVICES FOR TRADING IN SHARES, STOCKS, FUTURES, CURRENCIES AND OTHER SECURITIES; FINANCIAL ANALYSIS AND ADVISORY SERVICES OF SECURITIES AND FUNDS (U.S. CLS. 100, 101 AND 102).

#### **CLASS 41—EDUCATION AND ENTERTAINMENT**

FOR EDUCATION AND TRAINING SERVICES, NAMELY, PROVIDING SEMINARS IN THE FIELD OF TRADING SHARES, STOCKS, FUTURES, CURRENCIES AND OTHER SECURITIES AND PROVIDING RELATED COURSE MATERIALS AND PUBLICATIONS SUCH AS BOOKS, MAGAZINES, PAPERS, CDS, DVDS, IN CONNECTION THEREWITH; EDUCATION, NAMELY, PROVIDING SEMINARS FOR TRADING SHARES, STOCKS, FUTURES, CURRENCIES AND OTHER SECURITIES; PROVIDING SEMINARS, WEBINARS, CONFERENCES CONCERNING TRADING SHARES, STOCKS, FUTURES, CURRENCIES AND OTHER SECURITIES; PROVIDING ON-LINE PUBLICATIONS, NAMELY, ARTICLES REGARDING TRADING SHARES, STOCKS, FUTURES, CURRENCIES AND OTHER SECURITIES; PROVIDING ON-LINE ELECTRONIC PUBLICATIONS, NAMELY, BOOKS, MAGAZINES AND PAPERS IN THE FIELD OF TRADING SHARES, STOCKS, FUTURES, CURRENCIES AND OTHER SECURITIES; PUBLICATION OF VIDEO AND AUDIO MATERIAL, NAMELY, MAGAZINES (U.S. CLS. 100, 101 AND 107).

SANI KHOURI, EXAMINING ATTORNEY

SN 79-083,426. ALSA GMBH, FED REP GERMANY, FILED 4-23-2010.

# ÖKO-step

THE MARK CONSISTS OF STANDARD CHARACTERS WITHOUT CLAIM TO ANY PARTICULAR FONT, STYLE, SIZE, OR COLOR.

PRIORITY DATE OF 11-2-2009 IS CLAIMED.  
OWNER OF INTERNATIONAL REGISTRATION 1041083 DATED 4-23-2010, EXPIRES 4-23-2020.

ÖKO" IS THE SHORT FORM OF THE GERMAN WORD "ÖKOLOGISCH" WHICH TRANSLATES IN ENGLISH TO "ECOLOGICAL" OR "ECOLOGICALLY."

#### **CLASS 10—MEDICAL APPARATUS**

FOR ORTHOPEDIC ARTICLES, NAMELY, ORTHOPEDIC FOOTWEAR, INCLUDING FOOTWEAR FOR REHABILITATION PURPOSES, FOR FOOT GYMNASTICS AND THERAPY, AND FOR WORK, LEISURE AND SPORT, INCLUDING SANDALS, CHILDREN'S SANDALS, GYMNASTIC SANDALS, OPEN-TOED SANDALS, BACKLESS SLIPPERS, SLIPPERS, SANDALS WITH HEEL STRAPS, HAND-SEWN SANDALS AND CLOGS, FEATURING FOOT BEDS AND FOOT MOULDS, OR WITH ORTHOPEDIC FOOT AND SHOE INSERTS, NAMELY, ANATOMICALLY SHAPED DEEP FOOT BEDS, ORTHOPEDIC FOOT PADS AND SHOE INSERTS, INSERTS TO PROTECT THE PRESSURE-SENSITIVE POINTS OF THE FOOT, FOOTRESTS, FITTED PARTS, HEEL CUPS, WEDGES, PADS, INSOLES AND SHAPED SOLES AND PARTS THEREFOR, NAMELY, SHAPED SOLES WITH FOAM CUSHIONS AND/OR FOAM PADS AND SHAPED SOLES IN THE FORM OF SOLID PLASTIC INSERTS WITH FOOT BEDS OR ANATOMICALLY SHAPED DEEP FOOT BEDS, MADE OF NATURAL CORK, THERMAL CORK, PLASTIC, LATEX OR FOAMED PLASTIC MATERIALS, INCLUDING OF ELASTIC COMPOUNDS OF CORK-LATEX OR PLASTIC-CORK MIXTURES, ALL AFOREMENTIONED GOODS FOR ORTHOPEDIC PURPOSES (U.S. CLS. 26, 39 AND 44).

#### **CLASS 25—CLOTHING**

FOR CLOTHING, NAMELY, UNDERWEAR, UNDERGARMENTS, HEADWEAR, GLOVES FOR CLOTHING, SHIRTS, NECKTIES, TIES, BOW TIES, EAR MUFFS, HEADBANDS, MITTENS AND SHORTS; FOOTWEAR, INCLUDING COMFORTABLE FOOTWEAR, SPORTS AND LEISURE FOOTWEAR, SPORTS AND LEISURE SHOES, WORK SHOES, SHOES AND SANDALS FOR MEN, FOOTWEAR FOR FOOT GYMNASTICS AND THERAPY AND FOR WORK, LEISURE AND SPORTS, INCLUDING SANDALS, CHILDREN'S SANDALS, GYMNASTIC SANDALS, OPEN-TOED SANDALS, BACKLESS SLIPPERS, SLIPPERS, SANDALS WITH HEEL STRAPS, HAND-SEWN SANDALS, CLOGS, FEATURING FOOT BEDS AND FOOT MOULDS, OR NON-ORTHOPEDIC FOOT AND SHOE INSERTS, NAMELY, ANATOMICALLY SHAPED DEEP FOOT BEDS, FOOT PADS AND SHOE INSERTS, INSERTS TO PROTECT THE PRESSURE-SENSITIVE POINTS OF THE FOOT, FOOTRESTS, FITTED PARTS, HEEL CUPS, WEDGES, PADS, INSOLES, HEELS, SOLES, PARTS OF SHOE BOTTOMS, FOOT BEDS AND SHAPED SOLES AND PARTS THEREFOR, NAMELY, NON-ORTHOPEDIC SHAPED SOLES AND FOOT BEDS IN THE FORM OF SOLID PLASTIC INSERTS WITH FOOT BEDS OR ANATOMICALLY SHAPED DEEP FOOT BEDS MADE OF NATURAL CORK, THERMAL CORK, OR PLASTIC, LATEX OR FOAMED PLASTIC MATERIALS, INCLUDING OF ELASTIC COMPOUNDS OF CORK-LATEX OR PLASTIC-CORK MIXTURES; NON-ORTHOPEDIC FOOTWEAR UPPERS AND COMPONENTS OF SHOES AND SHOE INSERTS, NAMELY, SHOE BOTTOM SYSTEMS COMPRISING AN OUTER SOLE AND A FOOT BED; ALL AFOREMENTIONED GOODS NOT FOR MEDICAL PURPOSES (U.S. CLS. 22 AND 39).

MICHELE SWAIN, EXAMINING ATTORNEY

SN 79-083,440. WOOGA GMBH, FED REP GERMANY, FILED 4-15-2010.

# Bubble Island

THE MARK CONSISTS OF STANDARD CHARACTERS WITHOUT CLAIM TO ANY PARTICULAR FONT, STYLE, SIZE, OR COLOR.

PRIORITY DATE OF 1-12-2010 IS CLAIMED.  
OWNER OF INTERNATIONAL REGISTRATION 1041125 DATED 4-15-2010, EXPIRES 4-15-2020.



**CLASS 9—ELECTRICAL AND SCIENTIFIC APPARATUS**

FOR COMPUTERS, RECORDED COMPUTER PROGRAMS FOR COMPUTER, VIDEO, ONLINE AND BROWSER GAMES, FOR DATABASE MANAGEMENT, AND FOR USING THE INTERNET AND WORLD WIDE WEB; DOWNLOADABLE COMPUTER PROGRAMS AND SOFTWARE FOR COMPUTER, VIDEO, ONLINE AND BROWSER GAMES, FOR DATABASE MANAGEMENT, AND FOR USING THE INTERNET AND WORLD WIDE WEB; RECORDED AND DOWNLOADABLE COMPUTER PROGRAMS, NAMELY, COMPUTER, VIDEO, ONLINE AND BROWSER GAMES AND COMPUTER GAME PROGRAMS FOR MOBILE PHONES (U.S. CLS. 21, 23, 26, 36 AND 38).

SN 79-083,538, KLOTH & KÖHNKEN TEEHANDEL GMBH, FED REP GERMANY, FILED 3-26-2010.

**CLASS 28—TOYS AND SPORTING GOODS**

FOR GAMES, NAMELY, BATTERY-POWERED COMPUTER GAMES WITH LCD SCREEN WHICH FEATURES ANIMATION AND SOUND EFFECTS, ELECTRONIC GAMES OTHER THAN THOSE ADAPTED FOR USE WITH AN EXTERNAL DISPLAY SCREEN OR MONITOR, ARCADE GAMES, BOARD GAMES AND CARD GAMES; ELECTRONIC GAMES, OTHER THAN THOSE ADAPTED FOR USE WITH TELEVISION RECEIVERS ONLY, NAMELY, ARCADE-TYPE ELECTRONIC VIDEO GAMES (U.S. CLS. 22, 23, 38 AND 50).

PRIORITY DATE OF 3-4-2010 IS CLAIMED. OWNER OF INTERNATIONAL REGISTRATION 1041400 DATED 3-26-2010, EXPIRES 3-26-2020.

NO CLAIM IS MADE TO THE EXCLUSIVE RIGHT TO USE "ORGANIC" AND "NACHHALTIG SUSTAINABLE", APART FROM THE MARK AS SHOWN.

THE COLOR(S) GREEN, BLACK AND WHITE IS/ARE CLAIMED AS A FEATURE OF THE MARK.

THE MARK CONSISTS OF THE WORDING, "NACHHALTIG SUSTAINABLE", IN WHITE DEPICTED ALONG THE INSIDE BORDER OF THE BLACK CIRCLE DESIGN FEATURING TWO GREEN BANDS AGAINST A WHITE BACKGROUND, AND THE WORDING, "ORGANIC BIO", IN WHITE SUPERIMPOSED OVER A GREEN LEAF DEPICTED IN THE CENTER OF A BLACK CIRCLE, AND WEB ADDRESS "WWW.FAIRBIOTEADE" BELOW THE LEAF DESIGN.

THE ENGLISH TRANSLATION OF "NACHHALTIG" IN THE MARK IS "SUSTAINABLE".

**CLASS 38—COMMUNICATION**

FOR PROVIDING INTERNET ACCESS THAT ALLOWS USERS TO VIEW INFORMATION IN THE FORM OF TEXT, IMAGES, SPEECH AND SOUNDS VIA AN INTERNET PAGE; INFORMATION TRANSMISSION VIA ELECTRONIC COMMUNICATIONS NETWORKS, NAMELY, ELECTRONIC TRANSMISSION OF INFORMATION IN THE FORM OF TEXT, IMAGES, SPEECH AND SOUNDS VIA AN INTERNET PAGE; RENTAL OF ACCESS TIME TO AN INTERNET PAGE; PROVIDING ACCESS TO COMPUTER PROGRAMS FOR INTERNET ACCESS IN DATA NETWORKS; VIDEO BROADCASTING FEATURING MOVIES, TELEVISION BROADCASTING, RADIO BROADCASTING, TELEVISION BROADCASTING SERVICES FEATURING VIDEO TEXT, TELETEXT PROGRAMS OR ADVERTISING SPOTS; PROVIDING ACCESS TO DATABASES; PROVIDING INTERNET ACCESS ALLOWING USERS TO ACCESS DATABASE INFORMATION FROM THE INTERNET (U.S. CLS. 100, 101 AND 104).

**CLASS 30—STAPLE FOODS**

FOR ORGANIC TEA NOT FOR MEDICAL PURPOSES (U.S. CL. 46).

**CLASS 42—SCIENTIFIC AND COMPUTER SERVICES**

FOR SCIENTIFIC AND TECHNOLOGICAL SERVICES, NAMELY, SCIENTIFIC RESEARCH; INDUSTRIAL RESEARCH SERVICES; CHEMICAL ANALYSIS; CHEMISTRY CONSULTATION AND RESEARCH IN THE FIELD OF CHEMISTRY; RESEARCH IN THE FIELD OF ENVIRONMENTAL PROTECTION; QUALITY CONTROL FOR OTHERS (U.S. CLS. 100 AND 101).

WARREN L. OLANDRIA, EXAMINING ATTORNEY

**CLASS 41—EDUCATION AND ENTERTAINMENT**

FOR ORGANIZING OF GAMES IN THE INTERNET; ENTERTAINMENT SERVICES, NAMELY, PROVIDING ONLINE COMPUTER GAMES, IN PARTICULAR, COMPUTER, VIDEO, ONLINE AND BROWSER GAMES ALL PROVIDED ONLINE; ENTERTAINMENT SERVICES, NAMELY, PROVIDING TEMPORARY USE OF NON-DOWNLOADABLE COMPUTER GAMES FOR MOBILE PHONES PROVIDED ON THE INTERNET; ENTERTAINMENT SERVICES, NAMELY, PROVIDING AN ONLINE COMPUTER GAME (U.S. CLS. 100, 101 AND 107).

KATHERINE E. HALMEN, EXAMINING ATTORNEY

SN 79-083,595, DOMENICO DE LUCIA S.P.A., ITALY, FILED 3-23-2010.



PRIORITY DATE OF 12-29-2009 IS CLAIMED. OWNER OF INTERNATIONAL REGISTRATION 1041511 DATED 3-23-2010, EXPIRES 3-23-2020.

THE NAME(S), PORTRAIT(S), AND/OR SIGNATURE(S) SHOWN IN THE MARK DOES NOT IDENTIFY A PARTICULAR LIVING INDIVIDUAL.

THE MARK CONSISTS OF THE WORDING IN THE STYLIZED LETTERS "DOMENICO DELUCIA" WITH THE WORDS ONE ON TOP OF THE OTHER AND BELOW THE OTHER WORDING IN THE STYLIZED LETTERS "LA NATURA PRATICA DEL GUSTO" ALL ENCLOSED IN THE STYLIZED FRAME CONSISTING OF QUADRILATERALS.

THE ENGLISH TRANSLATION OF "LA NATURA PRATICA DEL GUSTO" IN THE MARK IS "THE PRACTICAL NATURE OF THE TASTE". THE WORDING "DOMENICO DELUCIA" HAS NO MEANING IN A FOREIGN LANGUAGE.

#### CLASS 29—MEATS AND PROCESSED FOODS

FOR PRESERVED, DRIED AND COOKED FRUITS AND VEGETABLES; JELLIES, JAMS, FRUIT SAUCES, NAMELY, APPLESAUCE AND CRANBERRY SAUCES; EGGS; EDIBLE OILS AND FATS (U.S. CL. 46).

#### CLASS 30—STAPLE FOODS

FOR COFFEE, TEA, COCOA, SUGAR, RICE, TAPIOCA, SAGO, ARTIFICIAL COFFEE; FLOUR AND PREPARATIONS MADE FROM CEREALS, NAMELY, PREPARED OR PACKAGED MEALS CONSISTING PRIMARILY OF GRAINS AND RICE, BAKERY PRODUCTS, NAMELY, BREAD, PIZZA; HONEY, TREACLE; YEAST, BAKING-POWDER; SALT, MUSTARD; VINEGAR, SAUCES; SPICES (U.S. CL. 46).

#### CLASS 31—NATURAL AGRICULTURAL PRODUCTS

FOR AGRICULTURAL, HORTICULTURAL AND FORESTRY PRODUCTS AND GRAINS NOT INCLUDED IN OTHER CLASSES, NAMELY, AGRICULTURAL SEEDS, BULBS FOR AGRICULTURAL PURPOSES, BULBS FOR HORTICULTURAL PURPOSES, SEEDS FOR HORTICULTURAL PURPOSES, AND WOOD CHIPS FOR USE AS A GROUND COVER; LIVE ANIMALS; FRESH FRUITS AND VEGETABLES; SEEDS, NAMELY, FLOWER SEEDS AND PLANT SEEDS; NATURAL PLANTS AND FLOWERS; FOODSTUFFS FOR ANIMALS; MALT, NAMELY, MALT FOR BREWING AND DISTILLING (U.S. CLS. 1 AND 46).

WARREN L. OLANDRIA, EXAMINING ATTORNEY

SN 79-083,808. PRODUKT.SCHMIEDE CONSULTING GMBH, AUSTRIA, FILED 3-23-2010.

# COFAIN 699

THE MARK CONSISTS OF STANDARD CHARACTERS WITHOUT CLAIM TO ANY PARTICULAR FONT, STYLE, SIZE, OR COLOR.

OWNER OF INTERNATIONAL REGISTRATION 1042175 DATED 3-23-2010, EXPIRES 3-23-2020.

NO CLAIM IS MADE TO THE EXCLUSIVE RIGHT TO USE "699", APART FROM THE MARK AS SHOWN.

THE WORDING "COFAIN" HAS NO MEANING IN A FOREIGN LANGUAGE.

#### CLASS 30—STAPLE FOODS

FOR COFFEE, TEA, COCOA, SUGAR, RICE, TAPIOCA, SAGO, ARTIFICIAL COFFEE; FLOUR AND PREPARATIONS MADE FROM CEREALS, NAMELY, BREAKFAST CEREALS, SNACK FOODS AND READY-TO-EAT CEREALS, BREAD, PASTRY AND CONFECTIONERY, NAMELY, FROZEN CONFECTIONS, CONFECTIONERY MADE OF SUGAR AND CRYSTAL SUGAR, EDIBLE AND FLAVORED ICES; HONEY, TREACLE; YEAST, BAKING-POWDER; SALT, MUSTARD; VINEGAR, CONDIMENTS, NAMELY, SAUCES; SPICES; ICE; CAFFEINE DRINKS, NAMELY, COFFEE AND TEA BASED BEVERAGES (U.S. CL. 46).

#### CLASS 32—LIGHT BEVERAGES

FOR BEERS; MINERAL AND AERATED WATERS AND OTHER NON-ALCOHOLIC DRINKS, NAMELY, NON-ALCOHOLIC BEER, CIDER, WINES AND MALT COOLERS; FRUIT DRINKS AND FRUIT JUICES; SYRUPS FOR MAKING BEVERAGES AND PREPARATIONS FOR MAKING BEVERAGES, NAMELY, FRUIT, SPORT AND ENERGY DRINKS (U.S. CLS. 45, 46 AND 48).

ERNEST SHOSHO, EXAMINING ATTORNEY

SN 79-083,819. NEO-CONCEPT (HOLDINGS) CO. LTD, HONG KONG, CHINA, FILED 3-4-2010.

# les 100 ciels

THE MARK CONSISTS OF STANDARD CHARACTERS WITHOUT CLAIM TO ANY PARTICULAR FONT, STYLE, SIZE, OR COLOR.

OWNER OF INTERNATIONAL REGISTRATION 1042212 DATED 3-4-2010, EXPIRES 3-4-2020.

THE ENGLISH TRANSLATION OF "LES" IN THE MARK IS "THE", AND THE ENGLISH TRANSLATION OF "CIELS" IN THE MARK IS "SKIES".

#### CLASS 18—LEATHER GOODS

FOR LEATHER AND IMITATIONS OF LEATHER AND GOODS MADE OF THESE MATERIALS, NAMELY, HANDBAGS, TRAVELLING BAGS, WALLETS, PURSES; RUCKSACKS; TRUNKS; ANIMAL SKINS, HIDES; UMBRELLAS, PARASOLS AND WALKING STICKS; WHIPS; HARNESS AND SADDLERY; CLOTHING FOR ANIMALS (U.S. CLS. 1, 2, 3, 22 AND 41).

#### CLASS 24—FABRICS

FOR TEXTILE, NAMELY, FELT AND NON-WOVEN TEXTILE FABRICS; FABRICS INCORPORATING SYNTHETIC FILAMENT YARN AND NATURAL YARN; TEXTILE GOODS, NAMELY, HAND TOWELS OF TEXTILE; HOUSEHOLD LINEN OF TEXTILE; BED BLANKETS; BLANKET THROWS; QUILTS; BED SHEETS; PILLOW COVERS; DUVET COVERS; CURTAINS AND DRAPERIES; TABLE NAPKINS OF TEXTILE; TABLE LINEN OF TEXTILE; GIFT WRAP OF TEXTILE, HANDKERCHIEFS OF TEXTILE (U.S. CLS. 42 AND 50).

#### CLASS 25—CLOTHING

FOR CLOTHING, NAMELY, JERSEYS, JUMPERS, CARDIGANS, PULLOVERS, T-SHIRT, WOMEN'S CLOTHING, NAMELY, DRESSES, SKIRTS, BLOUSES, TOPS, SHIRTS; TROUSERS, SHORTS, BERMUDA SHORTS, JACKETS, WAISTCOATS, VESTS, MEN'S SUITS, STOCKINGS, SOCKS, SHOES, HATS, BERETS, SCARVES, GLOVES, UNDERWEAR; ARTICLES OF CLOTHING OF LEATHER OR IMITATIONS OF LEATHER, NAMELY, COATS, PANTS; BELTS (U.S. CLS. 22 AND 39).

#### CLASS 42—SCIENTIFIC AND COMPUTER SERVICES

FOR PRODUCT DEVELOPMENT, SCIENTIFIC RESEARCH AND DESIGN SERVICES RELATING TO CLOTHING, FOOTWEAR, HEADGEAR, TEXTILES AND TEXTILES GOODS; FASHION DESIGN SERVICES; CONSULTANCY, ADVICE AND INFORMATION SERVICES RELATING TO ALL AFORESAID (U.S. CLS. 100 AND 101).

ALLISON SCHRODY, EXAMINING ATTORNEY

SN 79-083,908. SAVOX COMMUNICATIONS OY AB (LTD), FINLAND, FILED 3-31-2010.

OWNER OF INTERNATIONAL REGISTRATION 1042594 DATED 5-28-2010, EXPIRES 5-28-2020.

## IMP-IP MOBIL PLATFORM

THE MARK CONSISTS OF STANDARD CHARACTERS WITHOUT CLAIM TO ANY PARTICULAR FONT, STYLE, SIZE, OR COLOR.

PRIORITY DATE OF 3-10-2010 IS CLAIMED.

OWNER OF INTERNATIONAL REGISTRATION 1042492 DATED 3-31-2010, EXPIRES 3-31-2020.

NO CLAIM IS MADE TO THE EXCLUSIVE RIGHT TO USE "MOBILE PLATFORM", APART FROM THE MARK AS SHOWN.

### CLASS 9—ELECTRICAL AND SCIENTIFIC APPARATUS

FOR COMMUNICATION EQUIPMENT AND ACCESSORIES FOR SAFETY AND SECURITY SOLUTIONS AND FOR MILITARY OPERATIONS, NAMELY, TWO-WAY COMMUNICATION CONTROL UNITS FOR USE TO COMMUNICATE VIA VOICE AND/OR DATA; DIGITAL INTERCOMMUNICATION SYSTEMS HAVING AT LEAST TWO OR MORE INTERCOM COMMAND MODULES, WEARABLE PERSONAL CONTROL UNITS, HEADSETS, SPEAKERS, REMOTE SPEAKERS, MICROPHONES AND ACCESSORIES AND CABLES THEREFORE; MOBILE RADIOS; MOBILE PHONES; HEADSETS; SPEAKERS; REMOTE SPEAKERS; MICROPHONES; RADIOS; PUSH-TO-TALK TWO WAY RADIOS; ELECTRONIC SECURITY ALARMS AND SENSORS; COMMUNICATION CABLES; BATTERIES FOR MOBILE RADIOS, MOBILE PHONES, RADIOS; SIGNAL AND SOUND AMPLIFIERS; RADIO INTERFACES FOR APPLICATION ON BREATHING MASKS AND ON PROTECTIVE HELMETS; RADIO TRANSCEIVERS FOR VOICE AND DATA COMMUNICATION; COMPUTER HARDWARE; COMMUNICATION SOFTWARE FOR USE WITH INTERCONNECTING COMPUTERS AND IN INTERCOMMUNICATION SYSTEMS; COMPUTER SOFTWARE USED FOR THE CONTROL OF VOICE AND DATA CONTROLLED INFORMATION AND COMMUNICATION DEVICES AND FOR SETTING UP AND CONFIGURING LOCAL AND WIDE AREA NETWORKS; CARRYING CASES FOR THE AFOREMENTIONED GOODS (U.S. CLS. 21, 23, 26, 36 AND 38).

### CLASS 38—COMMUNICATION

FOR TELECOMMUNICATIONS, NAMELY, TELECOMMUNICATIONS CONSULTATION, CONSULTATION IN THE FIELD OF AUDIO, TEXT, AND DATA TRANSMISSION AND COMMUNICATION, TELECOMMUNICATION ACCESS SERVICES, TRANSFER OF DATA BY TELECOMMUNICATION, TRANSMISSION OF VOICE, DATA AND DOCUMENTS IN THE FIELD OF SEARCH AND RESCUE OPERATIONS AND FIRE FIGHTING OPERATIONS, TRANSMISSION OF VOICE DATA AND DOCUMENTS IN THE FIELD OF ENVIRONMENTAL PROTECTION, PROVIDING ACCESS TO PICTURES, VIDEO, ALARM STATUS BUILDING PLANS AND OTHER BUILDING AND SECURITY INFORMATION AT A REMOTE STATION, WIRELESS TELEPHONE SERVICES, TELECOMMUNICATION GATEWAY AND ISDN SERVICES, TRANSMISSION AND RECEPTION OF DATABASE INFORMATION VIA TELECOMMUNICATION NETWORKS (U.S. CLS. 100, 101 AND 104).

RUDY R. SINGLETON, EXAMINING ATTORNEY

SN 79-083,937. ISTITUTO LEONARDA VACACRI, ITALY, AND SPAZIO VISIVO SOC. COOP. A.R.L., ITALY, FILED 5-28-2010.

## NOBE NO OBSTACLE TO EMOTION

THE MARK CONSISTS OF STANDARD CHARACTERS WITHOUT CLAIM TO ANY PARTICULAR FONT, STYLE, SIZE, OR COLOR.

PRIORITY DATE OF 12-1-2009 IS CLAIMED.

### CLASS 9—ELECTRICAL AND SCIENTIFIC APPARATUS

FOR TELEVISION APPARATUS FOR PROJECTION PURPOSES; SOUND TRANSMITTING APPARATUS; ELECTRONIC APPARATUS, NAMELY, MOTION DETECTORS THAT EMIT SCENT; TOUCH PANELS; ELECTRIC SOUND VIBRATION SENSORS FOR ENJOYING WORKS OF ART; WORKSTATION COMPRISED OF COMPUTER HARDWARE AND SOFTWARE FOR GATHERING AND TRANSMITTING IMAGES, SOUND, VIBRATION AND SCENT FOR ENJOYING WORKS OF ART (U.S. CLS. 21, 23, 26, 36 AND 38).

### CLASS 10—MEDICAL APPARATUS

FOR ELECTRONIC APPARATUS WITH MULTISENSORY DEVICES THAT UTILIZES LIGHT, SOUND, SCENT DISPENSERS AND VIBRATION FOR RELAXATION THERAPY WHICH HELPS TO ENJOY WORKS OF ART FOR THERAPEUTIC PURPOSES; VIBRATION GENERATING APPARATUS FOR MEDICAL THERAPEUTIC USE; INFRARED RADIATOR UNITS FOR THERAPEUTIC PURPOSES (U.S. CLS. 26, 39 AND 44).

KATHERINE M. DUBRAY, EXAMINING ATTORNEY

SN 79-083,967. KARVER, FRANCE, FILED 1-25-2010.



PRIORITY DATE OF 9-28-2009 IS CLAIMED.

OWNER OF INTERNATIONAL REGISTRATION 1042659 DATED 1-25-2010, EXPIRES 1-25-2020.

THE MARK CONSISTS OF THE WORD "KARVER" AND TO THE RIGHT OF THIS WORD ARE FOUR CURVED TRIANGLES SPACED IN SUCH A WAY TO CREATE THE LETTER "K".

### CLASS 6—METAL GOODS

FOR PULLEYS OF METAL; PULLEYS OF METAL ATTACHED BY A LACING LINE THROUGH THE CENTRE; PULLEYS OF METAL WITH INTEGRATED LOAD SENSORS; METAL MARINE HARDWARE, NAMELY, THIMBLES; BOTTOM SHEAVES MADE OF METAL WHICH ARE USED FOR REDUCING THE TENSION ON A HALYARD OF THE SAIL; SNAP HOOKS MADE OF METAL WHICH USE A SPRING-ACTIVATED LOCKING MECHANISM FOR CLOSING AND UNLOCKING USED FOR SAILING NAVIGATION; METAL SHACKLES FOR LIFTING AND RIGGING; ALL OF THE AFOREMENTIONED GOODS INTENDED FOR SAILING NAVIGATION (U.S. CLS. 2, 12, 13, 14, 23, 25 AND 50).

**CLASS 12—VEHICLES**

FOR SAIL FURLERS WHICH ARE USED FOR FURLING SAILS AROUND THE EDGES OF SAILS; FURLERS WHICH ARE USED FOR FURLING SAILS AROUND THE EDGES OF SAILS WITH INTEGRATED LOAD SENSORS; BOAT HOOKS, NAMELY, NON-METAL BOAT HOOKS SPECIALLY DESIGNED FOR USE TO HOLD BOAT ACCESSORIES IN THE BOAT; PROTECTIVE COVERS FOR TURRETS WHICH ARE THE LOWER PART OF THE FURLER FIXED TO THE DECK OF THE BOAT AND USED FOR FURLING THE SAIL; FRICTION SHEAVES WHICH HAVE THE ROPE TURNING AROUND THE SHEAVE WITH NO-ROTATION AND CAUSING FRICTION; FURLING LINE BLOCKS WHICH ARE USED FOR SECURING A ROPE; STRUCTURAL PARTS FOR SAIL BOATS, NAMELY, RAILS WHICH ARE CONNECTED TO A BOAT HULL FOR SECURING SAILS ON A BOAT; CARTS FOR SECURING SAILS ON A BOAT; ALL THE AFOREMENTIONED GOODS INTENDED FOR SAILING NAVIGATION (U.S. CLS. 19, 21, 23, 31, 35 AND 44).

**CLASS 20—FURNITURE AND ARTICLES NOT OTHERWISE CLASSIFIED**

FOR PULLEYS OF PLASTIC; PULLEYS OF PLASTIC MATERIALS ATTACHED BY A LACING LINE THROUGH THE CENTRE; PULLEYS OF PLASTIC MATERIALS WITH INTEGRATED LOAD SENSORS; BOTTOM SHEAVES OF PLASTIC MATERIALS WHICH ARE USED FOR REDUCING THE TENSION ON A HALYARD OF THE SAIL; PROTECTIVE COVERS FOR SWIVELS; MARINE HARDWARE MADE OF PLASTIC, NAMELY, THIMBLES; ALL THE AFOREMENTIONED GOODS INTENDED FOR SAILING NAVIGATION (U.S. CLS. 2, 13, 22, 25, 32 AND 50).

**CLASS 22—CORDAGE AND FIBERS**

FOR NON-METAL FURLING LINES SOLD AS AN INTEGRAL COMPONENT OF A SAIL HANDLING SYSTEM USED FOR SAILING NAVIGATION (U.S. CLS. 1, 2, 7, 19, 22, 42 AND 50).

SIMON TENG, EXAMINING ATTORNEY

SN 79-083,987. GIEMME BRANDSCORPORATE S.P.A., I-25026 PONTEVICO (BS), ITALY, FILED 5-28-2010.

# CALIBAN

THE MARK CONSISTS OF STANDARD CHARACTERS WITHOUT CLAIM TO ANY PARTICULAR FONT, STYLE, SIZE, OR COLOR.

PRIORITY DATE OF 12-11-2009 IS CLAIMED.

OWNER OF INTERNATIONAL REGISTRATION 1042726 DATED 5-28-2010, EXPIRES 5-28-2020.

**CLASS 18—LEATHER GOODS**

FOR LEATHER AND IMITATIONS OF LEATHER, AND GOODS MADE OF THESE MATERIALS AND NOT INCLUDED IN OTHER CLASSES, NAMELY, LEATHER CASES, KEY CASES, HANDBAGS; ANIMAL SKINS, HIDES; TRUNKS AND TRAVELING BAGS; UMBRELLAS, PARASOLS AND WALKING STICKS; WHIPS, HARNESS AND SADDLERY (U.S. CLS. 1, 2, 3, 22 AND 41).

**CLASS 25—CLOTHING**

FOR CLOTHING, NAMELY, SHIRTS, PANTS, SKIRTS, DRESSES, TOPS AND BOTTOMS; FOOTWEAR; HEADGEAR, NAMELY, HATS AND CAPS (U.S. CLS. 22 AND 39).

KATHERINE M. DUBRAY, EXAMINING ATTORNEY

SN 79-084,070. ISOGENICA LTD, CAMBRIDGESHIRE, UNITED KINGDOM, FILED 1-22-2010.

# ISOGENICA

THE MARK CONSISTS OF STANDARD CHARACTERS WITHOUT CLAIM TO ANY PARTICULAR FONT, STYLE, SIZE, OR COLOR.

OWNER OF INTERNATIONAL REGISTRATION 1042806 DATED 1-22-2010, EXPIRES 1-22-2020.

**CLASS 5—PHARMACEUTICALS**

FOR DIAGNOSTIC AND THERAPEUTIC SYNTHETIC PEPTIDES, PROTEINS, MOLECULES, ANTIBODIES, POLYPEPTIDES AND POLYMERS FOR THE TREATMENT OF VIRAL, METABOLIC, ENDOCRINE, MUSCULOSKELETAL, CARDIOVASCULAR, CARDIOPULMONARY, GENITOURINARY, SEXUAL DYSFUNCTION, ONCOLOGICAL, HEPATOLOGICAL, OPHTHALMIC, RESPIRATORY, NEUROLOGICAL, GASTROINTESTINAL, HORMONAL, DERMATOLOGICAL, PSYCHIATRIC AND IMMUNE SYSTEM RELATED DISEASES AND DISORDERS; DIAGNOSTIC PREPARATIONS FOR MEDICAL USE; PHARMACEUTICAL PREPARATIONS AND SUBSTANCES FOR THE TREATMENT OF VIRAL, METABOLIC, ENDOCRINE, MUSCULOSKELETAL, CARDIOVASCULAR, CARDIOPULMONARY, GENITOURINARY, SEXUAL DYSFUNCTION, ONCOLOGICAL, HEPATOLOGICAL, OPHTHALMIC, RESPIRATORY, NEUROLOGICAL, GASTROINTESTINAL, HORMONAL, DERMATOLOGICAL, PSYCHIATRIC AND IMMUNE SYSTEM RELATED DISEASES AND DISORDERS (U.S. CLS. 6, 18, 44, 46, 51 AND 52).

**CLASS 42—SCIENTIFIC AND COMPUTER SERVICES**

FOR SCIENTIFIC, PHARMACEUTICAL, MEDICAL, BIOLOGICAL, BIOCHEMICAL, BIOTECHNOLOGY AND DIAGNOSTIC RESEARCH IN THE FIELD OF IN-VITRO SCREENING AND PROTEIN ENGINEERING; BIOCHEMICAL RESEARCH AND DEVELOPMENT; BIOTECHNOLOGICAL ENGINEERING, NAMELY, THE ENGINEERING OF PEPTIDES, PROTEINS, MOLECULES, ANTIBODIES, POLYPEPTIDES AND POLYMERS (U.S. CLS. 100 AND 101).

**CLASS 45—PERSONAL AND LEGAL SERVICES**

FOR LICENSING OF INTELLECTUAL PROPERTY; LICENSING OF TECHNOLOGY IN THE FIELD OF IN-VITRO SCREENING AND PROTEIN ENGINEERING RELATING TO DISCOVERY OF PEPTIDES FOR THERAPEUTIC AND NON-THERAPEUTIC APPLICATIONS (U.S. CLS. 100 AND 101).

GINA HAYES, EXAMINING ATTORNEY

SN 79-084,173. AAVA MOBILE OY, FINLAND, FILED 2-9-2010.

# AAVA MOBILE

THE MARK CONSISTS OF STANDARD CHARACTERS WITHOUT CLAIM TO ANY PARTICULAR FONT, STYLE, SIZE, OR COLOR.

PRIORITY DATE OF 11-26-2009 IS CLAIMED.

OWNER OF INTERNATIONAL REGISTRATION 1043065 DATED 2-9-2010, EXPIRES 2-9-2020.

NO CLAIM IS MADE TO THE EXCLUSIVE RIGHT TO USE "MOBILE", APART FROM THE MARK AS SHOWN.

**CLASS 9—ELECTRICAL AND SCIENTIFIC APPARATUS**

FOR WIRELESS TELEPHONY APPARATUS; TELEMATICS APPARATUS, NAMELY, WIRELESS INTERNET DEVICES WHICH PROVIDE TELEMATIC SERVICES AND HAVE A CELLULAR PHONE FUNCTION; WIRELESS COMMUNICATION DEVICES FEATURING VOICE, DATA AND IMAGE TRANSMISSION INCLUDING VOICE, TEXT AND PICTURE MESSAGING, A VIDEO AND STILL IMAGE CAMERA, ALSO FUNCTIONAL TO PURCHASE MUSIC, GAMES, VIDEO AND SOFTWARE APPLICATIONS OVER THE AIR FOR DOWNLOADING TO THE DEVICE; DIGITAL TELEPHONE PLATFORMS AND SOFTWARE; MOBILE COMPUTING AND OPERATING PLATFORMS CONSISTING OF DATA TRANSCEIVERS, WIRELESS NETWORKS AND GATEWAYS FOR COLLECTION AND MANAGEMENT OF DATA; DIGITAL TELEPHONE PLATFORMS AND SOFTWARE; MOBILE COMPUTING AND OPERATING PLATFORMS CONSISTING OF DATA TRANSCEIVERS, WIRELESS NETWORKS AND GATEWAYS FOR COLLECTION AND MANAGEMENT OF DATA (U.S. CLS. 21, 23, 26, 36 AND 38).

**CLASS 42—SCIENTIFIC AND COMPUTER SERVICES**

FOR DESIGN AND DEVELOPMENT OF COMPUTER HARDWARE AND SOFTWARE; DESIGN AND DEVELOPMENT OF MOBILE DEVICES, COMPUTER SOFTWARE TO BE USED IN MOBILE DEVICES AND MOBILE DEVICE PRODUCT PLATFORMS (U.S. CLS. 100 AND 101).

PAUL MORENO, EXAMINING ATTORNEY

**CLASS 9—ELECTRICAL AND SCIENTIFIC APPARATUS**

FOR MEASURING, SIGNALING, AND CHECKING APPARATUS AND INSTRUMENTS, NAMELY, DETECTORS FOR FLUX, HEAT, AND PRESSURE OF STEAM AND WATER, PRESSURE MEASURING APPARATUS FOR THE PRESSURE OF STEAM AND WATER, FLUID MEASURING AND CONTROL APPARATUS, NAMELY, THERMOMETERS NOT FOR MEDICAL PURPOSES, THERMOSTATS, CALORIMETERS, WATER LEVEL INDICATORS, WATER METERS, NAMELY, DOMESTIC AND COMMERCIAL WATER METERS, AND WATER COUNTERS; ELECTROTECHNICAL APPARATUS, NAMELY, CONTROL AND REGULATING APPARATUS FOR CONTROL AND REGULATION OF FLUX, HEAT, AND PRESSURE OF STEAM AND WATER, THERMAL ENERGY METERS FOR MEASURING, CONTROLLING, OR REGULATING FLUX, HEAT, OR PRESSURE OF STEAM AND WATER, TRANSMITTERS AND RECEIVERS FOR ELECTRONIC SIGNALS FOR MEASURING, SIGNALING, AND CONTROLLING OF FLUX, HEAT, AND PRESSURE OF STEAM AND WATER; PARTS AND COMPONENTS FOR ALL THE AFORESAID GOODS; COMPUTER SOFTWARE FOR THE MEASUREMENT, REGULATION, AND CONTROL OF THE FLUX, HEAT, AND PRESSURE OF STEAM AND WATER (U.S. CLS. 21, 23, 26, 36 AND 38).

**CLASS 11—ENVIRONMENTAL CONTROL APPARATUS**

FOR HEATING, BATHING, AND WATER CONDUCTING APPARATUS AND INSTALLATIONS, AND SANITARY APPARATUS AND INSTALLATIONS, NAMELY, WATER HEATERS, STEAM GENERATING INSTALLATIONS, STEAM ACCUMULATORS, FLUSHING VALVES FOR WATER CONTROL AND REGULATION, PRESSURE WATER TANKS, PIPE AERATORS FOR WATER CONDUCTING APPARATUS AND INSTALLATIONS, WATER-FILTERING APPARATUS, GAS BOILERS, STEAM BOILERS, HEATING BOILERS, HEATING ELEMENTS, AND HEATING APPARATUS, NAMELY, HOT AIR OVENS; PLUMBING, SANITARY, AND WATER FITTINGS, NAMELY, OUTLET VALVES, CONNECTOR VALVES, SAFETY VALVES, SHUT-OFF VALVES, FREE-FLOW VALVES, PISTON VALVES, SLIDING STEM VALVES, PLUMBING MIXER TAPES, PIPELINE COCKS, BACKFLOW PREVENTERS, SPIN MANIFOLDS FOR WATER CONTROL AND REGULATION, SYSTEM-ADAPTER VALVES, VALVE MANIFOLDS FOR PLUMBING AND WATER REGULATION, CIRCULATION VALVES; CONNECTING PLUMBING FITTINGS BEING PARTS OF WATER PIPES AND HEATING RADIATORS; THREADED PLUMBING FITTINGS FOR SANITARY PIPES; RADIATOR CAPS AND VALVES; WATER-FILTERING APPARATUS; VALVES, SLIDING VALVES AND TAP FAUCETS OF METAL AND PLASTIC FOR LIQUID MEDIA FOR PLUMBING; FLUSHING VALVES FOR SANITARY APPARATUS AND DEVICES; PRESSURE WATER TANKS; PIPE AERATORS FOR WATER CONDUCTING APPARATUS AND INSTALLATIONS; FILTERS FOR APPARATUS AND INSTALLATIONS INVOLVING STEAM AND WATER; PIPES BEING PARTS OF HEATING BOILERS AND SANITARY INSTALLATIONS, COILS BEING PARTS FOR HEATING INSTALLATIONS; THERMOSTATIC VALVES AS PARTS OF HEATING INSTALLATIONS; PARTS AND COMPONENTS FOR ALL THE AFORESAID GOODS (U.S. CLS. 13, 21, 23, 31 AND 34).

**CLASS 37—CONSTRUCTION AND REPAIR**

FOR INSTALLATION AND REPAIR OF HEATING, WATER CONDUCTING AND IRRIGATION INSTALLATIONS, NAMELY, COMMISSIONING, INSTALLATION, REPAIR, CLEANING AND MAINTENANCE OF MEASURING, SIGNALING AND CHECKING APPARATUS AND INSTRUMENTS, NAMELY, DETECTORS, PRESSURE MEASURING APPARATUS, FLUID MEASURING AND CONTROL APPARATUS, THERMOMETERS NOT FOR MEDICAL PURPOSES, THERMOSTATS, CALORIMETERS, WATER LEVEL INDICATORS, WATER METERS, NAMELY, DOMESTIC AND COMMERCIAL WATER METERS, COUNTERS, METERS, ELECTROTECHNICAL APPARATUS, NAMELY, CONTROL AND REGULATING APPARATUS, THERMAL ENERGY ME-

SN 79-084,175. ROSSWEINER ARMATUREN UND MESSGERÄTE; GMBH & CO. OHG, FED REP GERMANY, FILED 2-22-2010.



PRIORITY DATE OF 8-25-2009 IS CLAIMED.  
OWNER OF INTERNATIONAL REGISTRATION 1043071 DATED 2-22-2010, EXPIRES 2-22-2020.  
THE MARK CONSISTS OF A HEXAGON WITH A CIRCLE INSIDE. TWO HORIZONTAL BARS EXTEND TO THE RIGHT FROM INSIDE THE CIRCLE.

TERS, TRANSMITTERS AND RECEIVERS FOR ELECTRONIC SIGNALS, HEATING, BATHING AND WATER CONDUCTING APPARATUS AND INSTALLATIONS, AND SANITARY APPARATUS AND INSTALLATIONS, FITTINGS, SANITARY AND WATER FITTINGS, IN PARTICULAR OUTLET VALVES, CONNECTOR VALVES, COMBINATION FITTINGS, SAFETY VALVES, SHUT-OFF FITTINGS, FREE-FLOW VALVES, PISTON VALVES, SLIDING STEM VALVES, MIXER TAPES FOR WATER PIPES, PIPELINE COCKS, BACKFLOW PREVENTERS, SPIN MANIFOLDS, SYSTEM-ADAPTER VALVES, VALVE MANIFOLDS, DISTRIBUTION STATIONS, PRE-WALL SYSTEMS FOR SANITARY INSTALLATIONS, CIRCULATION VALVES, CONNECTING FITTINGS FOR WATER METERS, WATER PIPES AND RADIATORS, THREADED FITTINGS FOR SANITARY PIPES, RADIATOR CAPS AND VALVES, REGULATING AND SAFETY ACCESSORIES FOR WATER PIPES AND WATER APPARATUS, WATER FILTERING APPARATUS, WATER DISPENSING APPARATUS, FEED WATER AERATORS, VALVES, SLIDING VALVES AND TAPS OF METAL AND PLASTIC FOR LIQUID MEDIA, FLUSHING VALVES, PRESSURE WATER TANKS, PIPE AERATORS, FILTERS BEING PARTS FOR HOUSEHOLD OR INDUSTRIAL INSTALLATIONS, PIPES BEING PARTS OF SANITARY INSTALLATIONS, NAMELY, PIPES FOR HEATING BOILERS, COILS BEING PARTS FOR HEATING INSTALLATIONS, THERMOSTAT VALVES BEING PARTS FOR HEATING INSTALLATIONS; PLUMBING (U.S. CLS. 100, 103 AND 106).

#### **CLASS 42—SCIENTIFIC AND COMPUTER SERVICES**

FOR CONSULTANCY RELATING TO THE CONSERVATION OF ENERGY, NAMELY, IN THE FIELDS OF HEATING, VENTILATION, AIR CONDITIONING, AND WATER HEATING; ENGINEERING CONSULTING SERVICES IN THE FIELDS OF HEATING, VENTILATION, AIR CONDITIONING, WATER HEATING, SANITATION ENGINEERING, AND ENERGY CONSERVATION; CALIBRATION, NAMELY, OF MEASURING, SIGNALING, AND MONITORING APPARATUS AND INSTRUMENTS IN RELATED TO HEATING, VENTILATION, AIR CONDITIONING, WATER HEATING, AND SANITATION DEVICES; TECHNICAL CONSULTANCY AND TECHNICAL PROJECT STUDIES WITH REGARD TO NEW PRODUCT DESIGN FOR MEASURING, SIGNALING AND CHECKING APPARATUS AND INSTRUMENTS, INCLUDING DETECTORS, PRESSURE MEASURING APPARATUS, FLUID MEASURING AND CONTROL APPARATUS, THERMOMETERS NOT FOR MEDICAL PURPOSES, THERMOSTATS, CALORIMETERS, WATER LEVEL INDICATORS, WATER METERS, INCLUDING DOMESTIC WATER METERS, COUNTERS, METERS, ELECTROTECHNICAL APPARATUS, NAMELY, CONTROL AND REGULATING APPARATUS, THERMAL ENERGY METERS, TRANSMITTERS AND RECEIVERS FOR ELECTRONIC SIGNALS, HEATING, BATHING AND WATER CONDUCTING APPARATUS AND INSTALLATIONS, AND SANITARY APPARATUS AND INSTALLATIONS, FITTINGS, SANITARY AND WATER FITTINGS, IN PARTICULAR OUTLET VALVES, CONNECTOR VALVES, COMBINATION FITTINGS, SAFETY VALVES, SHUT-OFF FITTINGS, FREE-FLOW VALVES, PISTON VALVES, SLIDING STEM VALVES, MIXER TAPES FOR WATER PIPES, PIPELINE COCKS, BACKFLOW PREVENTERS, SPIN MANIFOLDS, SYSTEM-ADAPTER VALVES, VALVE MANIFOLDS, DISTRIBUTION STATIONS, PRE-WALL SYSTEMS FOR SANITARY INSTALLATIONS, CIRCULATION VALVES, CONNECTING FITTINGS FOR WATER METERS, WATER PIPES AND RADIATORS, THREADED FITTINGS FOR SANITARY PIPES, RADIATOR CAPS AND VALVES, REGULATING AND SAFETY ACCESSORIES FOR WATER PIPES AND WATER APPARATUS, WATER FILTERING APPARATUS, WATER DISPENSING APPARATUS, FEED WATER AERATORS, VALVES, SLIDING VALVES AND TAPS OF METAL AND PLASTIC FOR LIQUID MEDIA, FLUSHING VALVES, PRESSURE WATER TANKS, PIPE AERATORS, FILTERS BEING PARTS FOR HOUSEHOLD OR INDUSTRIAL INSTALLATIONS, PIPES BEING PARTS OF SANITARY INSTALLATIONS, IN PARTICULAR PIPES FOR HEATING BOILERS, COILS BEING PARTS FOR HEATING INSTALLATIONS, THERMOSTAT VALVES BEING PARTS FOR HEATING INSTALLATIONS; COMPUTER SOFTWARE DESIGN AND

UPDATING; INSTALLATION, MAINTENANCE, REPAIR AND SERVICING OF COMPUTER SOFTWARE (U.S. CLS. 100 AND 101).

KATHLEEN M. VANSTON, EXAMINING ATTORNEY

SN 79-084,207. WILHELM HEDRICH VAKUUMANLAGEN; GMBH & CO. KG, FED REP GERMANY, FILED 3-11-2010.

# Hedrich

THE MARK CONSISTS OF STANDARD CHARACTERS WITHOUT CLAIM TO ANY PARTICULAR FONT, STYLE, SIZE, OR COLOR.

PRIORITY DATE OF 9-11-2009 IS CLAIMED.

OWNER OF INTERNATIONAL REGISTRATION 1043173 DATED 3-11-2010, EXPIRES 3-11-2020.

THE WORD(S) "HEDRICH" HAS NO MEANING IN A FOREIGN LANGUAGE.

SEC. 2(F).

#### **CLASS 6—METAL GOODS**

FOR GOODS OF METAL FOR VACUUM EQUIPMENT AND VACUUM PROCESS EQUIPMENT, NAMELY, METAL PIPES AND TUBES AND METAL FITTINGS THEREFOR; PIPELINES OF METAL, NAMELY, DRAIN PIPES; VESSELS IN THE NATURE OF METAL STORAGE TANKS, STORAGE AND BUFFER TANKS OF METAL FOR CAST RESIN CONSTITUENTS (U.S. CLS. 2, 12, 13, 14, 23, 25 AND 50).

#### **CLASS 7—MACHINERY**

FOR MACHINE TOOLS, NAMELY, COIL WINDING MACHINES, HELIX COIL WINDING MACHINES IN THE FORM OF LINEAR WINDING MACHINES, TABLE-MOUNTED WINDING MACHINES FOR WINDING WIRE, FOIL, PAPER, AND GLASS; NEEDLE WINDING MACHINES, FLYER WINDING MACHINES FOR WINDING WIRE, FOIL, PAPER, AND GLASS; REVOLVING TRANSFER MACHINES, NAMELY, HEAT TRANSFER PRESSES, AND COIL PRODUCTION MACHINES, NAMELY, COIL WINDING MACHINES; ACCESSORIES FOR THE AFOREMENTIONED GOODS, NAMELY, MACHINE ENGINES AND BELTS; EVACUATION MACHINES AND VACUUM PROCESS EQUIPMENT, NAMELY, IMPREGNATING AND DEGASSING MACHINES FOR VOLTAGE, HIGH VOLTAGE AND EXTRA-HIGH VOLTAGE CABLES AS WELL AS FOR PLASTICS AND SYNTHETIC RESINS; MACHINES FOR PREPARING INSULATING MATERIAL FOR ELECTRICAL TRANSFORMERS AND ELECTRICAL INSTRUMENT TRANSFORMERS; MACHINE PARTS, NAMELY, CONDENSERS, MOVABLE OIL PROCESSING MACHINES, NAMELY, OIL FILTERING AND DEGASSING AND DRYING MACHINES; VACUUM CASTING MACHINES, NAMELY, MACHINES FOR PREPARING AND CASTING SYNTHETIC RESINS; MACHINE PARTS, NAMELY, VACUUM PUMPS AND VACUUM PUMPING UNITS CONSISTING OF VACUUM PUMPS AND ACCESSORIES, NAMELY, DRIVES AND SHAFT BEARINGS FOR VACUUM PUMPS, AND CONTROL UNITS FOR VACUUM PUMPS, OIL SEPARATORS, CONDENSATE SEPARATORS, COOLERS FOR OPERATING LIQUIDS, DUST SEPARATORS, CONDENSERS FOR VAPORS, AIR FILTERS FOR MECHANICAL PURPOSES, STEAM CONDENSERS AND FLANGES; MACHINE PARTS, NAMELY, VALVES, FEEDER PUMPS FOR OPERATING AND PROCESSING LIQUIDS, DOSING PUMPS FOR MACHINES; MACHINE PARTS, NAMELY, SURFACE CONDENSERS FOR CONDENSING VAPORS; MACHINE PARTS, NAMELY, VALVES; MACHINE PARTS, NAMELY, HEAT EXCHANGERS; MACHINE PARTS, NAMELY, VACUUM-TIGHT MECHANICAL AND ELECTRICAL BUSHINGS (U.S. CLS. 13, 19, 21, 23, 31, 34 AND 35).

**CLASS 9—ELECTRICAL AND SCIENTIFIC APPARATUS**

FOR ELECTRICAL AND ELECTRONIC APPARATUS AND INSTRUMENTS FOR CONTROL, SIGNAL AND MONITORING PURPOSES, NAMELY, FLOW SWITCHES FOR MONITORING AND CONTROLLING THE FLOW OF GASES OR LIQUIDS; AUTOMATED PROCESS CONTROL SYSTEM, NAMELY, MICRO-PROCESSOR BASED HARDWARE AND SOFTWARE USED TO MONITOR THE STATUS OF INDUSTRIAL PROCESSES, NAMELY, VACUUM PROCESS TECHNOLOGY; ELECTRONIC VALVES FOR CONTROLLING GAS OR FLUIDS; GAS DETECTORS FOR DETECTING THE PRESENCE OF GAS; COMPUTER PROGRAMS FOR DATA PROCESSING, AND CONTROL AND AUTOMATION SOFTWARE IN THE FIELD OF VACUUM PROCESS TECHNOLOGY (U.S. CLS. 21, 23, 26, 36 AND 38).

**CLASS 11—ENVIRONMENTAL CONTROL APPARATUS**

FOR HEATING, STEAM GENERATION, COOLING AND DRYING DEVICES, NAMELY, HEAT DRYING OVENS, HEAT EXCHANGERS, COOLING UNITS FOR INDUSTRIAL PURPOSES, ELECTRIC FLOW HEATERS; DRYING DEVICES AND SYSTEMS, NAMELY, INDUSTRIAL VACUUM DRYING APPARATUS FOR USE IN DRYING AND IMPREGNATING ELECTRIC COMPONENTS; DEGASSING VESSELS FOR HEATING SYSTEMS IN THE NATURE OF FILTERS AND FILTERING DEVICES FOR GAS CONDITIONING; DRYING MACHINES, NAMELY, VACUUM DRYERS FOR VOLTAGE, HIGH VOLTAGE AND EXTRA-HIGH VOLTAGE CABLES AS WELL AS FOR PLASTICS AND SYNTHETIC RESINS (U.S. CLS. 13, 21, 23, 31 AND 34).

**CLASS 41—EDUCATION AND ENTERTAINMENT**

FOR TRAINING AND ADVANCED TRAINING FOR USERS IN THE FIELD OF COMPUTER SOFTWARE, DATA PROCESSING, CONTROL AND AUTOMATION TECHNOLOGY (U.S. CLS. 100, 101 AND 107).

**CLASS 42—SCIENTIFIC AND COMPUTER SERVICES**

FOR DESIGN, DEVELOPMENT, INSTALLATION AND MAINTENANCE OF COMPUTER PROGRAMS FOR DATA PROCESSING, IN PARTICULAR SOFTWARE DEVELOPMENT FOR CONTROL AND AUTOMATION TECHNOLOGY; SERVICES OF ENGINEERS, NAMELY, ENGINEERING SERVICES; TECHNICAL CONSULTANCY FOR USERS IN THE FIELD OF COMPUTER SOFTWARE (U.S. CLS. 100 AND 101).

SUE LAWRENCE, EXAMINING ATTORNEY

SN 79-084,251. MINISTERO DELLE POLITICHE AGRICOLE.; ALIMENTARI E FORESTALI -; DIPARTIMENTO DELLE POLITICHE; COMPETITIVE DEL MONDO RURALE; E DELLA QUALITA' -; DIREZIONE GENERALE PER LO SVILUPPO AGROALIMENTARE.; LA QUALITA' E LA TUTELA; DEL CONSUMATORE, ITALY, FILED 4-16-2010.

**CIPOLLOTTO NOCERINO**

THE MARK CONSISTS OF STANDARD CHARACTERS WITHOUT CLAIM TO ANY PARTICULAR FONT, STYLE, SIZE, OR COLOR.

PRIORITY DATE OF 2-8-2010 IS CLAIMED.  
OWNER OF INTERNATIONAL REGISTRATION 1043270 DATED 4-16-2010, EXPIRES 4-16-2020.

NO CLAIM IS MADE TO THE EXCLUSIVE RIGHT TO USE "CIPOLLOTTO", APART FROM THE MARK AS SHOWN.

THE ENGLISH TRANSLATION OF "CIPOLLOTTO NOCERINO" IN THE MARK IS NOCERA ONION.

THE CERTIFICATION MARK, AS INTENDED TO BE USED BY PERSONS AUTHORIZED BY THE CERTIFIER, IS INTENDED TO CERTIFY THAT THE GOODS PROVIDED ORIGINATE THROUGHOUT THE BASIN OF THE SARNO VALLEY IN THE TERRITORY OF ARGO NOCERINO IN THE PROVINCE OF SALERNO AND THE SOUTH-WESTERN PART OF THE PROVINCE OF NAPLES IN ITALY, AND THAT THE PREPARATION, PRODUCTION, AND/OR PROCESSING OF THE GOODS TAKE PLACE ACCORDING TO THE STANDARD OF RECORD.

**CLASS 29—MEATS AND PROCESSED FOODS**

FOR PRESERVED ONIONS (U.S. CL. 46).

**CLASS 31—NATURAL AGRICULTURAL PRODUCTS**

FOR FRESH ONIONS (U.S. CLS. 1 AND 46).  
MARK RADEMACHER, EXAMINING ATTORNEY

SN 79-084,328. AJINOMOTO EUROLYSINE, PARIS, FRANCE, FILED 3-31-2010.

# EVAPIG

THE MARK CONSISTS OF STANDARD CHARACTERS WITHOUT CLAIM TO ANY PARTICULAR FONT, STYLE, SIZE, OR COLOR.

OWNER OF INTERNATIONAL REGISTRATION 0955232 DATED 10-23-2007, EXPIRES 10-23-2017.

**CLASS 9—ELECTRICAL AND SCIENTIFIC APPARATUS**

FOR CALCULATING MACHINES; DATA PROCESSING EQUIPMENT, COMPUTER HARDWARE, AND COMPUTER PERIPHERAL EQUIPMENT FOR REVIEW, MEASUREMENT, AND ANALYSIS FOR OPTIMIZATION OF ANIMAL GROWTH AND PHYSIOLOGICAL PARAMETERS AND CALCULATION OF ENERGY, AMINO ACID AND PHOSPHORUS VALUES OF INGREDIENTS AND DIETS FOR ANIMALS; COMPUTER SOFTWARE PROGRAMS FOR REVIEW, MEASUREMENT, AND ANALYSIS FOR OPTIMIZATION OF ANIMAL GROWTH AND PHYSIOLOGICAL PARAMETERS AND CALCULATION OF ENERGY, AMINO ACID AND PHOSPHORUS VALUES OF INGREDIENTS AND DIETS FOR ANIMALS (U.S. CLS. 21, 23, 26, 36 AND 38).

**CLASS 35—ADVERTISING AND BUSINESS**

FOR UPDATING OF DATABASES, NAMELY, DATABASE MANAGEMENT (U.S. CLS. 100, 101 AND 102).

**CLASS 42—SCIENTIFIC AND COMPUTER SERVICES**

FOR EVALUATION AND TESTING OF THE VALUE OF INGREDIENTS AND DIETS FOR ANIMALS; ENGINEERING SERVICES, NAMELY, EVALUATION, RESEARCH, ESTIMATION, AND WRITING OF REPORTS IN THE FIELDS OF SCIENCE AND TECHNOLOGY, NAMELY, EXPERT REPORTS OF ENGINEERS; ANALYSIS AND INDUSTRIAL RESEARCH SERVICES IN THE FIELD OF OPTIMIZATION AND ANALYSIS OF ANIMAL GROWTH AND PHYSIOLOGICAL PARAMETERS; SOFTWARE DESIGN AND DEVELOPMENT; INSTALLATION, UPDATING, RENTAL OF COMPUTER SOFTWARE; CONSULTANCY SERVICES WITH REGARD TO SOFTWARE; MAINTENANCE OF COMPUTER SOFTWARE; COMPUTER PROGRAMMING; DATABASE DESIGN AND DEVELOPMENT; RENTAL OF WEB SERVERS (U.S. CLS. 100 AND 101).

TRICIA SONNEBORN, EXAMINING ATTORNEY

SN 79-084,434. MAC GROUP S.R.L., ITALY, FILED 3-30-2010.

## UNIQUES SPECIAL ONES

THE MARK CONSISTS OF STANDARD CHARACTERS WITHOUT CLAIM TO ANY PARTICULAR FONT, STYLE, SIZE, OR COLOR.

PRIORITY DATE OF 3-23-2010 IS CLAIMED.  
OWNER OF INTERNATIONAL REGISTRATION 1043612 DATED 3-30-2010, EXPIRES 3-30-2020.

### CLASS 25—CLOTHING

FOR LEATHER COATS; LEATHER JACKETS; TROUSERS OF LEATHER; COATS; OVERCOATS; RAINCOATS; JACKETS BEING CLOTHING; ANORAKS; PARKAS; SPORTS JACKETS; OVERALLS; WAISTCOATS; TROUSERS; JEANS; TRACKSUITS; BERMUDA SHORTS; SKIRTS; SWEATERS; SINGLET; VESTS; SHIRTS; T-SHIRTS; SWEAT SHIRTS; BLOUSES; CHEMISETTES; CAMISOLES; CARDIGANS; JERSEYS BEING CLOTHING; DRESSING GOWNS; PULLOVERS; JUMPERS; SUITS AND DRESSES; HOSIERY; NIGHTGOWNS; PYJAMAS; UNDERWEAR; PANTS; SLIPS; PANTIES; UNDERPANTS; BRASSIERES; PETTICOATS; SOCKS; STOCKINGS; STOCKING SUSPENDERS; GARTERS; LEGGINGS; TIGHTS; GLOVES BEING CLOTHING; MUFFS BEING CLOTHING; HEADBANDS BEING CLOTHING; SCARVES; FOULARDS BEING CLOTHING ARTICLE; SHAWLS; NECKERCHIEFS; NECKTIES; BELTS BEING CLOTHING; SASHERS; BRACES FOR CLOTHING; WRISTBANDS BEING CLOTHING; BATHING SUITS; BATH ROBES; PAREOS; HATS; BERETS; CAPS BEING HEADWEAR; CAP PEAKS; SHOES; BOOTS; SANDALS; ESPADRILLES; SLIPPERS; CLOGS; SKI BOOTS; SNOWBOARD BOOTS; TRACK SHOES; RUNNING SHOES; GYMNASTIC SHOES; BEACH SHOES; KNICKERS (U.S. CLS. 22 AND 39).

### CLASS 35—ADVERTISING AND BUSINESS

FOR ORGANIZATION OF EVENTS, EXHIBITIONS, FAIRS AND SHOWS FOR COMMERCIAL, PROMOTIONAL AND ADVERTISING PURPOSES; ORGANIZING, PROMOTING AND CONDUCTING EXHIBITIONS, TRADE SHOWS AND EVENTS FOR BUSINESS PURPOSES; PROVIDING MARKETING AND PROMOTION OF SPECIAL EVENTS; PUBLIC RELATIONS; ADVERTISING, MARKETING AND PROMOTION SERVICES; CONTESTS AND INCENTIVE AWARD PROGRAMS TO PROMOTE THE SALE OF PRODUCTS AND SERVICES OF OTHERS; PROMOTING THE SALE OF GOODS AND SERVICES OF OTHERS THROUGH THE DISTRIBUTION OF PRINTED MATERIAL AND PROMOTIONAL CONTESTS; PROMOTING THE GOODS AND SERVICES OF OTHERS BY ARRANGING FOR SPONSORS TO AFFILIATE THEIR GOODS AND SERVICES WITH AN AWARDS PROGRAM, A SPORTS COMPETITION AND SPORTING ACTIVITIES; ORGANIZATION OF BUSINESS CONVENTIONS; ADVERTISING AND MARKETING; ADVERTISING CONSULTATION; BUSINESS ADMINISTRATION CONSULTANCY (U.S. CLS. 100, 101 AND 102).

### CLASS 38—COMMUNICATION

FOR PROVISION OF ACCESS TO A GLOBAL COMPUTER NETWORK; STREAMING OF AUDIO, VISUAL AND AUDIOVISUAL MATERIAL VIA A GLOBAL COMPUTER NETWORK; TRANSMISSION AND DISTRIBUTION OF DATA OR AUDIO VISUAL IMAGES VIA A GLOBAL COMPUTER NETWORK OR THE INTERNET; COMMUNICATION SERVICES, NAMELY, TRANSMISSION OF VOICE, AUDIO, VISUAL IMAGES AND DATA BY TELECOMMUNICATIONS NETWORKS, WIRELESS COMMUNICATION NETWORKS, THE INTERNET, INFORMATION SERVICES NETWORKS AND DATA NETWORKS; PROVIDING ON-LINE CHAT ROOMS AND ELECTRONIC BULLETIN BOARDS FOR TRANSMISSION OF MESSAGES AMONG USERS IN THE FIELD

OF SPECIAL EVENTS, EXHIBITIONS, FAIRS AND SHOWS, CONTESTS AND COMPETITIONS; NEWS AGENCY SERVICES FOR ELECTRONIC TRANSMISSION; PROVIDING AN ON-LINE FORUM FOR COMPANIES TO SHOWCASE, DISPLAY, DEMONSTRATE AND PROMOTE NEW AND INNOVATIVE IDEAS, PRODUCTS AND SERVICES IN THE CONVENTION/MEETING MANAGEMENT ARENA; COMMUNICATION SERVICES, NAMELY, ELECTRONIC TRANSMISSION OF DATA AND DOCUMENTS AMONG USERS OF COMPUTERS; PROVIDING ACCESS TO DATABASES (U.S. CLS. 100, 101 AND 104).

### CLASS 41—EDUCATION AND ENTERTAINMENT

FOR ORGANIZING AND ARRANGING EXHIBITIONS FOR ENTERTAINMENT PURPOSES; ENTERTAINMENT SERVICES, NAMELY, CONDUCTING FAIRS NOT FOR COMMERCIAL PURPOSES; ARRANGING AND CONDUCTING SPECIAL EVENTS FOR SOCIAL ENTERTAINMENT PURPOSES; ORGANIZING CULTURAL AND ARTS EVENTS; SPECIAL EVENT PLANNING FOR SOCIAL ENTERTAINMENT PURPOSES; ARRANGING OF CONTESTS; ARRANGING OF BEAUTY CONTESTS; CONDUCTING AND ORGANIZING ENTERTAINMENT AND SOCIAL EVENTS, NAMELY, CAR SHOWS, CAR EXHIBITIONS, CAR COMPETITIONS; ENTERTAINMENT SERVICES IN THE NATURE OF AUTOMOBILE RACING AND EXHIBITIONS; MEETING AND SEMINAR ARRANGING; ORGANIZING COMMUNITY SPORTING AND CULTURAL EVENTS; ORGANISATION OF SPORTS COMPETITIONS; ENTERTAINMENT, NAMELY, LIVE MUSIC CONCERTS; PUBLICATION OF MANUALS, BOOKS, MAGAZINES, BROCHURES, PAMPHLETS, AND PRINTED EDUCATIONAL AND TEACHING MATERIAL (U.S. CLS. 100, 101 AND 107).

### CLASS 43—HOTEL AND RESTAURANT SERVICES

FOR ARENA SERVICES, NAMELY, PROVIDING GENERAL PURPOSE FACILITIES FOR EXHIBITIONS, CONVENTIONS, SPECIAL EVENTS, TRADE FAIRS, CONTESTS AND COMPETITIONS; PROVIDING SOCIAL MEETING, BANQUET AND SOCIAL FUNCTION FACILITIES; PROVIDING BANQUET AND SOCIAL FUNCTION FACILITIES FOR SPECIAL OCCASIONS; RESTAURANT, BAR AND CATERING SERVICES; PROVIDING TEMPORARY ACCOMMODATION (U.S. CLS. 100 AND 101).

MARTHA FROMM, EXAMINING ATTORNEY

SN 79-084,486. DANIEL TANZER, A-6111 VOLDERS, AUSTRIA, AND JÖRG HARRER, A-8614 BREITENAU, AUSTRIA, FILED 3-23-2010.



PRIORITY DATE OF 12-23-2009 IS CLAIMED.  
OWNER OF INTERNATIONAL REGISTRATION 1043754 DATED 3-23-2010, EXPIRES 3-23-2020.



THE MARK CONSISTS OF A CIRCULAR DESIGN WITH THE STYLIZED WORDING "MAN OF THE DAY" THEREIN.

#### CLASS 14—JEWELRY

FOR PRECIOUS METALS AND THEIR ALLOYS, MEDALS, JEWELLERY, CLOCKS, WATCHES (U.S. CLS. 2, 27, 28 AND 50).

#### CLASS 25—CLOTHING

FOR CLOTHING, NAMELY, T-SHIRTS, SHORTS, HOODED JACKETS, HATS, AND CAPS (U.S. CLS. 22 AND 39).

#### CLASS 41—EDUCATION AND ENTERTAINMENT

FOR ENTERTAINMENT SERVICES, NAMELY, PROVIDING A WEBSITE FEATURING ENTERTAINMENT INFORMATION (U.S. CLS. 100, 101 AND 107).  
MAUREEN DALL, EXAMINING ATTORNEY

SN 79-084,598. MORE SALES TECHNOLOGY LIMITED, UNITED KINGDOM, FILED 2-9-2010.



PRIORITY DATE OF 8-10-2009 IS CLAIMED.  
OWNER OF INTERNATIONAL REGISTRATION 1044053 DATED 2-9-2010, EXPIRES 2-9-2020.

THE MARK CONSISTS OF THE WORD "SALESROCKET": ABOVE THE LETTERS "ET" IN "SALESROCKET" APPEARS A FIGURE OF A ROCKET SHIP AIMING UP AND TO THE RIGHT, THE ROCKET SHIP HAS THREE FINS AT ITS BOTTOM END AND TWO STRIPES AROUND ITS CIRCUMFERENCE, ONE NEAR THE CONE TIP AND ONE AT THE TOP OF THE FINS.

#### CLASS 9—ELECTRICAL AND SCIENTIFIC APPARATUS

FOR COMPUTER SOFTWARE FOR USE IN DATABASE MANAGEMENT; COMPUTER SOFTWARE FOR USE IN DATABASE MANAGEMENT IN RELATION TO INTERNET MARKETING AND PROMOTION; COMPUTER SOFTWARE FOR USE IN DATABASE MANAGEMENT IN RELATION TO INVENTORY MANAGEMENT AND ORDER PROCESSING (U.S. CLS. 21, 23, 26, 36 AND 38).

#### CLASS 35—ADVERTISING AND BUSINESS

FOR ADVERTISING, MARKETING AND PROMOTION SERVICES PROVIDED VIA A COMPUTER DATABASE AND THE INTERNET; BUSINESS ADMINISTRATION SERVICES FOR THE PROCESSING OF PRODUCT AND SERVICE ORDERS MADE VIA THE INTERNET; COMPILATION OF ADVERTISEMENTS FOR USE AS WEB-PAGES ON THE INTERNET; CUSTOMER RELATIONSHIP MANAGEMENT PROVIDED VIA A COMPUTER DATABASE AND THE INTERNET; INVENTORY CONTROL PROVIDED VIA A COMPUTER DATABASE AND THE INTERNET; BUSINESS MANAGEMENT CONSULTANCY (U.S. CLS. 100, 101 AND 102).

#### CLASS 42—SCIENTIFIC AND COMPUTER SERVICES

FOR COMPUTER SOFTWARE DESIGN (U.S. CLS. 100 AND 101).  
STEVEN JACKSON, EXAMINING ATTORNEY

SN 79-084,607. YACHT CLUB COSTA SMERALDA, ITALY, FILED 5-12-2010.



PRIORITY DATE OF 5-3-2010 IS CLAIMED.  
OWNER OF INTERNATIONAL REGISTRATION 1044073 DATED 5-12-2010, EXPIRES 5-12-2020.

THE COLOR(S) LIGHT BLUE, BLUE, GREEN, RED AND WHITE IS/ARE CLAIMED AS A FEATURE OF THE MARK.  
THE MARK CONSISTS OF A LETTER "A" FORMED BY A STYLIZED PAIR OF SAILBOAT SAILS. THE UPPER PORTION OF THE MARK IS FORMED BY TWO LIGHT BLUE TRIANGLES WITH A RED FOUR-POINTED STAR, OUTLINED IN WHITE, IN THE RIGHT TRIANGLE, AND THE BOTTOM PORTION IS FORMED BY TWO BLUE QUADRILATERALS. GREEN, WHITE, AND RED HORIZONTAL STRIPES SEPARATE THE TWO PORTIONS.

#### CLASS 18—LEATHER GOODS

FOR LEATHER AND IMITATIONS OF LEATHER; GOODS MADE OF LEATHER AND IMITATION LEATHER, NAMELY, LEATHER BRIEFCASES, LEATHER PURSES; ANIMAL SKINS, HIDES; TRUNKS AND TRAVELLING BAGS; UMBRELLAS, PARASOLS AND WALKING STICKS; WHIPS, HARNESS AND SADDLERY (U.S. CLS. 1, 2, 3, 22 AND 41).

#### CLASS 25—CLOTHING

FOR CLOTHING, NAMELY, SHIRTS, PANTS, DRESSES, JACKETS, CARDIGANS, BELTS, TROUSERS, SHORTS, JEANS, COATS, RAINWEAR, WIND-CHEATERS, SPORT COATS, BEACHWEAR, BATH ROBES, SOCKS AND STOCKINGS, PYJAMAS; FOOTWEAR; HEADGEAR, NAMELY, HATS, CAPS (U.S. CLS. 22 AND 39).  
LIEF MARTIN, EXAMINING ATTORNEY

SN 79-084,629. SCANDINAVIAN REGULATORY SERVICES AB, SWEDEN, FILED 5-11-2010.

# EMERADE

PRIORITY DATE OF 11-13-2009 IS CLAIMED.  
OWNER OF INTERNATIONAL REGISTRATION 1044142 DATED 5-11-2010, EXPIRES 5-11-2020.

**CLASS 5—PHARMACEUTICALS**

FOR PREPARATIONS FOR HUMAN USE IN THE FORM OF INJECTION LIQUIDS FOR THE TREATMENT OF ALLERGY, AVAILABLE ON PRESCRIPTION ONLY (U.S. CLS. 6, 18, 44, 46, 51 AND 52).

**CLASS 10—MEDICAL APPARATUS**

FOR MEDICAL APPARATUS AND INSTRUMENTS FOR INJECTION PURPOSES (U.S. CLS. 26, 39 AND 44).  
APRIL ROACH, EXAMINING ATTORNEY

SN 79-084,631. YACHT CLUB COSTA SMERALDA, ITALY,  
FILED 5-12-2010.



PRIORITY DATE OF 5-3-2010 IS CLAIMED.  
OWNER OF INTERNATIONAL REGISTRATION 1044150  
DATED 5-12-2010, EXPIRES 5-12-2020.

THE COLOR(S) LIGHT BLUE, BLUE, GREEN, RED AND WHITE IS/ARE CLAIMED AS A FEATURE OF THE MARK.  
THE MARK CONSISTS OF A LETTER "A" FORMED BY A STYLIZED PAIR OF SAILBOAT SAILS. THE UPPER PORTION OF THE MARK IS FORMED BY TWO LIGHT BLUE TRIANGLES WITH A RED FOUR-POINTED STAR, OUTLINED IN WHITE, IN THE RIGHT TRIANGLE, AND THE BOTTOM PORTION IS FORMED BY TWO BLUE QUADRILATERALS. GREEN, WHITE, AND RED HORIZONTAL STRIPES SEPARATE THE TWO PORTIONS.

**CLASS 9—ELECTRICAL AND SCIENTIFIC APPARATUS**

FOR SCIENTIFIC, NAUTICAL, SURVEYING, PHOTOGRAPHIC, CINEMATOGRAPHIC, OPTICAL, WEIGHING, MEASURING, SIGNALLING, CHECKING, LIFE-SAVING AND TEACHING APPARATUS AND INSTRUMENTS, NAMELY, TELESCOPES, MICROSCOPES, CAMERAS, DIGITAL SIGNAL PROCESSORS, CENTERING APPARATUS FOR PHOTOGRAPHIC TRANSPARENCIES, PHOTOMETERS, CAMCORDERS, CINEMATOGRAPHIC CAMERAS, FILM CUTTING APPARATUS, BINOCULARS, SPECTACLES, PRECISION BALANCES, SCALES, BAROMETRES, THERMOMETERS, SIGNAL OR ALARM BELLS, AIR ANALYSIS APPARATUS, NAMELY, GAS DETECTORS FOR DETECTING THE PRESENCE OF GAS IN THE AIR; APPARATUS AND INSTRUMENTS FOR CONDUCTING, SWITCHING, TRANSFORMING, ACCUMULATING, REGULATING OR CONTROLLING ELECTRICITY, NAMELY, ADAPTERS, ELECTRIC ACCUMULATORS, ELECTRIC ACTUATORS, ELECTRICAL CABLES, ELECTRIC WIRES, CONDUCTORS AND CONNECTION FITTINGS THEREFORE, ELECTRICAL SWITCHES, ELECTRICAL DISTRIBUTION PANELS, SWITCHBOARD, ELECTRICAL CONTROL PANELS, DISTRIBUTION CABINETS AND SWITCH CABINETS, ELECTRIC POWER SUPPLY DEVICES, SWITCH-MODE ELECTRICAL POWER SUPPLIES, SWITCHING POWER SUPPLIES, HIGH-FREQUENCY CHANGEOVER ELECTRICAL SWITCHES, MATCHING NETWORK SWITCHES AND TRANSFORMERS FOR ELECTRIC POWER AND ELECTRIC POWER SUPPLIES; APPARATUS FOR RECORDING, TRANSMISSION OR REPRODUCTION OF SOUND OR IMAGES; MAGNETIC DATA CARRIERS, NAMELY, BLANK MAGNETIC DATA CARRIERS; RECORDING DISCS, NAMELY, BLANK RECORDABLE OPTICAL DISC, BLANK RECORD DISKS, BLANK DISKETTES; AUTOMATIC VENDING MACHINES AND MECHANISMS FOR COIN-OPERATED APPARATUS; CASH REGISTERS, CALCULATING MACHINES, DATA PROCESSING EQUIPMENT AND COMPUTERS; FIRE-EXTINGUISHING APPARATUS; COMPUTER OPERATING RECORDED PROGRAMS (U.S. CLS. 21, 23, 26, 36 AND 38).

**CLASS 12—VEHICLES**

FOR VEHICLES, NAMELY, LAND VEHICLES, BOATS, SAIL SHIPS, MOTOR YACHTS, YACHTS; APPARATUS FOR LOCOMOTION BY LAND, AIR OR WATER, NAMELY, AIRPLANES, LOCOMOTIVES, SHIPS AND BOATS (U.S. CLS. 19, 21, 23, 31, 35 AND 44).

**CLASS 14—JEWELRY**

FOR PRECIOUS METALS AND THEIR ALLOYS; GOODS IN PRECIOUS METALS OR COATED THEREWITH, NAMELY, CUFF LINKS OF PRECIOUS METAL; JEWELLERY, PRECIOUS STONES; HOROLOGICAL AND CHRONOMETRIC INSTRUMENTS (U.S. CLS. 2, 27, 28 AND 50).

**CLASS 16—PAPER GOODS AND PRINTED MATTER**

FOR PAPER AND CARDBOARD; GOODS OF PAPER AND CARDBOARD, NAMELY, BOXES OF PAPER AND CARDBOARD; PRINTED MATTER, NAMELY, PRINTED CALENDARS; BOOKBINDING MATERIAL; PHOTOGRAPHS; STATIONERY; ADHESIVES FOR STATIONERY OR HOUSEHOLD PURPOSES; ARTISTS' MATERIALS, NAMELY, MOLDS FOR MODELLING CLAYS; PAINT BRUSHES; TYPEWRITERS; OFFICE REQUISITES, NAMELY, STAPLERS, RUBBER BANDS, HOLE-PUNCHES; PRINTED INSTRUCTIONAL AND TEACHING MATERIAL IN THE FIELD OF SPORT ACTIVITIES AND SAILING; PLASTIC MATERIALS FOR PACKAGING, NAMELY, PLASTIC BAGS FOR PACKAGING; PRINTERS' TYPE; PRINTING BLOCKS (U.S. CLS. 2, 5, 22, 23, 29, 37, 38 AND 50).

**CLASS 22—CORDAGE AND FIBERS**

FOR ROPES; STRING; NETS, NAMELY, FISHING NETS; TENTS; AWNINGS; TARPAULINS; SAILS; SACKS AND BAGS FOR THE TRANSPORTATION OR STORAGE OF MATERIALS IN BULK; PADDING AND STUFFING MATERIALS, NOT OF RUBBER, PAPER OR PLASTICS; RAW FIBROUS TEXTILE MATERIALS (U.S. CLS. 1, 2, 7, 19, 22, 42 AND 50).

**CLASS 28—TOYS AND SPORTING GOODS**

FOR GAMES AND PLAYTHINGS, NAMELY, DART BOARDS; GYMNASTIC AND SPORTING ARTICLES, NAMELY, GYMNASTIC PARALLEL BARS; DECORATIONS FOR CHRISTMAS TREES (U.S. CLS. 22, 23, 38 AND 50).

**CLASS 41—EDUCATION AND ENTERTAINMENT**

FOR EDUCATION, NAMELY, PROVIDING CLASSES, SEMINARS, WORKSHOPS IN THE FIELD OF SPORT ACTIVITIES, SAILING; PROVIDING OF TRAINING IN THE FIELD OF SPORT ACTIVITIES, SAILING; ENTERTAINMENT IN THE NATURE OF YACHT RACES; SPORTING AND CULTURAL ACTIVITIES, NAMELY, CONDUCTING EVENTS INVOLVING SURFING, SAIL BOARDING AND KITE SURFING (U.S. CLS. 100, 101 AND 107).

LIEF MARTIN, EXAMINING ATTORNEY

**CLASS 41—EDUCATION AND ENTERTAINMENT**

FOR MULTIMEDIA PUBLICATION OF ELECTRONIC BOOKS AND PUBLICATIONS (U.S. CLS. 100, 101 AND 107).

KELLY TRUSILO, EXAMINING ATTORNEY

SN 79-085,000. ROTALIANA S.R.L., ITALY, FILED 2-15-2010.

SN 79-084,928. DIGITAL BOOKS, S.L., E-08006 BARCELONA, SPAIN, FILED 6-23-2010.



The logo for AMABOOK features the word "AMABOOK" in a bold, sans-serif font. The letters "AMA" are in black, and "BOOK" is in purple. The letter "A" in "BOOK" is shaded with a white-to-purple gradient.

OWNER OF INTERNATIONAL REGISTRATION 1044760 DATED 6-23-2010, EXPIRES 6-23-2020.

THE COLOR(S) VIOLET, BLACK AND GREY IS/ARE CLAIMED AS A FEATURE OF THE MARK.

THE MARK CONSISTS OF THE WORD "AMABOOK" WITH THE LETTERS "AMA" APPEARING IN BLACK AND THE LETTERS "BOOK" APPEARING IN VIOLET, WITH THE CORNER OF THE SECOND LETTER "A" OVERLAPPING THE LETTER "B" AND APPEARING IN GREY. THE COLOR WHITE CONSTITUTES SHADING, AND IS NOT PART OF THE MARK.

**CLASS 9—ELECTRICAL AND SCIENTIFIC APPARATUS**

FOR ELECTRONIC PUBLICATIONS, NAMELY, BOOKS ON COMPANIES AND BUSINESS, BOOKS ON CULTURAL THEMES AND WORKS OF FICTION, ESSAYS ON ECONOMICS, SOCIOLOGY, CONSUMPTION AND GEOPOLITICS, SELF-HELP BOOKS, BOOKS ON ROMANCE AND ROMANTIC NOVELS ALL OF THESE BEING STORED ON ELECTRONIC MEDIA (U.S. CLS. 21, 23, 26, 36 AND 38).

**CLASS 35—ADVERTISING AND BUSINESS**

FOR ONLINE RETAIL STORE SERVICES FEATURING ELECTRONIC PUBLICATIONS, NAMELY, BOOKS ON COMPANIES AND BUSINESS, BOOKS ON CULTURAL THEMES AND WORKS OF FICTION, ESSAYS ON ECONOMICS, SOCIOLOGY, CONSUMPTION AND GEOPOLITICS, SELF-HELP BOOKS, BOOKS ON ROMANCE AND ROMANTIC NOVELS ALL OF THESE BEING STORED ON ELECTRONIC MEDIA (U.S. CLS. 100, 101 AND 102).



PRIORITY DATE OF 10-6-2009 IS CLAIMED.

OWNER OF INTERNATIONAL REGISTRATION 1044983 DATED 2-15-2010, EXPIRES 2-15-2020.

OWNER OF U.S. REG. NO. 2,819,713.

THE MARK CONSISTS OF THE STYLIZED WORDING "ROTALIANA" WITHIN A SQUARE WITH A SMALL CIRCLE IN THE MIDDLE OF THE SQUARE.

**CLASS 9—ELECTRICAL AND SCIENTIFIC APPARATUS**

FOR ELECTRICAL SOCKETS, ELECTRONIC CALENDARS, BATTERY CHARGERS, ELECTRIC WIRES, ELECTRICAL MULTIPLE SOCKETS, MULTI-OUTLET SOCKET BLOCKS, ELECTRONIC ALBUMS; ELECTRONIC DIARIES, ELECTRICAL OUTLETS, ELECTRICAL MULTIPLE OUTLETS, CIRCUIT BREAKERS, ELECTRIC CABLES, COMPUTER NETWORK HUBS, DIGITAL MEDIA HUBS, ELECTRICAL TRANSFORMERS; COMPUTER PERIPHERAL DEVICES, ELECTRONIC AGENDAS, TIME RECORDING APPARATUS, CHRONOGRAPHS FOR USE AS SPECIALIZED TIME RECORDING APPARATUSES, TIME CLOCKS, BEING TIME RECORDING DEVICES; TELEPHONE TRANSMITTERS AND RECEIVERS, PERSONAL STEREOs, CD AND MP3 PLAYERS, RADIOS, HEADPHONES, LOUD-SPEAKERS; AUDIO AND VIDEO-RECEIVERS; ELECTRICAL SOCKETS AND PLUGS, COVERS FOR ELECTRIC OUTLETS, ELECTRIC CONNECTIONS, ELECTRIC SWITCHES, ELECTRIC LIGHT DIMMERS, LIGHT CONDUCTING FILAMENTS; REMOTE CONTROLS FOR RADIOS AND LAMPS (U.S. CLS. 21, 23, 26, 36 AND 38).

**CLASS 11—ENVIRONMENTAL CONTROL APPARATUS**

FOR LAMPS, CHANDELIERS, TABLE LAMPS, WALL LAMPS, CEILING LAMPS, FLOOR LAMPS, CEILING LIGHTS, HANGING LAMPS, LIGHT DIFFUSERS; MULTIFUNCTIONAL LAMPS, COMPOSED OF A LAMP WITH AN AMPLIFIER, A RADIO, A LOUDSPEAKER, A BATTERY CHARGER, AN AUDIO-VIDEO REPRODUCER, ALL SOLD AS A UNIT; MULTIFUNCTIONAL LAMPS, COMPOSED OF A LAMP, A MULTI-OUTLET ELECTRICAL SOCKET, AND A SPACE TO TIDY ELECTRIC WIRES, ELECTRIC CABLES AND TRANSFORMERS, ALL SOLD AS A UNIT; MULTIFUNCTIONAL LAMPS, COMPOSED OF A LAMP, PHOTOGRAPH HOLDER, A MULTI-OUTLET ELECTRICAL SOCKET, A DIGITAL CALENDAR, A DIGITAL ALARM CLOCK, A BATTERY CHARGER AND A SPACE TO TIDY ELECTRIC WIRES, ELECTRIC CABLES AND TRANSFORMERS, ALL SOLD AS A UNIT; ELECTRIC LAMPS INCORPORATING DEODORIZING APPARATUS AND FRAGRANCE DIFFUSERS; FLUORESCENT LAMPS, HALOGEN LAMPS, ELECTRIC CANDELABRAS, ELECTRIC TRACK LIGHTING UNITS, ELECTRIC LIGHTING FIXTURES, ELECTRIC LANTERNS, SWINGING LAMPS, BRACKET LAMPS; CEILING LIGHT FIXTURES, LAMP SHADES, LIGHT BULBS, LAMP SHADE HOLDERS, FITTINGS FOR HANGING LAMPS, NAMELY, HANGINGS FOR LAMPS AND LAMP HANGING SUPPORTS, SOCKETS FOR ELECTRIC LIGHTS, LIGHTING TUBES (U.S. CLS. 13, 21, 23, 31 AND 34).

ALICE BENMAMAN, EXAMINING ATTORNEY

SN 79-085.436. OBSHCHESTVO S OGRANICHENNOY OTVETSTVENNOSTYU "PLANETA LITA-TSVET M", MOSKVA, RUSSIAN FED., FILED 4-29-2010.



studio

PRIORITY DATE OF 12-10-2009 IS CLAIMED.

OWNER OF INTERNATIONAL REGISTRATION 1046005 DATED 4-29-2010, EXPIRES 4-29-2020.

THE MARK CONSISTS OF A STYLIZED LETTER "R" INSIDE A PLAIN SINGLE LINE SQUARE WITH THE STYLIZED WORDING "STUDIO" BELOW THE SQUARE DESIGN.

**CLASS 3—COSMETICS AND CLEANING PREPARATIONS**

FOR ADHESIVES FOR AFFIXING FALSE EYELASHES; ADHESIVES FOR AFFIXING FALSE HAIR; ADHESIVES FOR COSMETIC PURPOSES; AFTERSHAVE LOTIONS; ALMOND MILK FOR COSMETIC PURPOSES; ALMOND OIL FOR COSMETIC PURPOSES; ALMOND SOAP; ALUM STONES FOR PERSONAL COSMETIC USE; PERFUME IN THE NATURE OF AMBER PERFUME; ANTIPERSPIRANT SOAP; ANTIPERSPIRANTS; AROMATIC ESSENTIAL OILS; ASTRINGENTS FOR COSMETIC PURPOSES; ESSENTIAL OILS, NAMELY, BADIAN ESSENCE; PERFUME OILS FOR FLOWER PERFUMES; BATH SALTS, NOT FOR MEDICAL PURPOSES; BEAUTY MASKS; BEARD DYES; BERGAMOT OIL; BLEACHING PREPARATIONS FOR COSMETIC PURPOSES; BLEACHING SALTS; BREATH

FRESHENING SPRAYS; CAKES OF TOILET SOAP; CLEANING PREPARATIONS; CLEANSING MILK FOR TOILET PURPOSES; HAIR COLOR REMOVING PREPARATIONS; COSMETIC CREAMS; COSMETIC DYES; MAKE UP KITS COMPRISED OF LIPSTICK, LIP GLOSS AND COSMETICS; COSMETIC PENCILS; COSMETIC PREPARATIONS FOR BATHS; COSMETIC PREPARATIONS FOR EYELASHES; COSMETIC PREPARATIONS FOR SKIN CARE; COSMETIC PREPARATIONS FOR SLIMMING PURPOSES; COSMETICS; COTTON STICKS FOR COSMETIC PURPOSES; COTTON WOOL FOR COSMETIC PURPOSES; CREAMS FOR LEATHER; DECORATIVE TRANSFERS FOR COSMETIC PURPOSES; DENTAL BLEACHING GELS; DENTIFRICES; DEODORANTS FOR PERSONAL USE; DEODORANT SOAP; DEGREASERS OTHER THAN FOR USE IN MANUFACTURING PROCESSES FOR USE IN HOUSEHOLD PURPOSES FOR OILY SKIN; DEPILATORIES; DEPILATORY PREPARATIONS; DEPILATORY WAX; DETERGENTS FOR HOUSEHOLD USE AND OTHER THAN FOR USE IN MANUFACTURING OPERATIONS AND FOR MEDICAL PURPOSES; DISINFECTANT SOAP; EAU DE COLOGNE; ESSENTIAL OILS; ESSENTIAL OILS OF CEDARWOOD; ESSENTIAL OILS OF CITRON; ESSENTIAL OILS OF LEMON; ETHEREAL OILS; ETHEREAL ESSENCES; FLOWER EXTRACTS SOLD AS A COMPONENT OF PERFUMES; EYEBROW COSMETICS; EYEBROW PENCILS; FALSE EYELASHES; FALSE NAILS; PERFUME IN THE NATURE OF FUMIGATING INCENSES; HAIR COLORANTS; HAIR DYES; HAIR LOTIONS; HAIR SPRAY; PERFUME OILS, NAMELY, HELIOTROPINE; HYALURONIC ACID FOR COSMETIC PURPOSES; HYDROGEN PEROXIDE FOR COSMETIC PURPOSES; PERFUME OILS, NAMELY, GAULTHERIA OIL AND GERANIOL; GREASES FOR COSMETIC PURPOSES; INCENSE; PERFUMES MADE OF IONONE; JASMINE OIL FOR PERSONAL USE; JAVELLE WATER FOR USE AS PERFUME; JOSS STICKS; LACQUER-REMOVING PREPARATIONS FOR COSMETIC PURPOSES; LAVENDER OIL; LAVENDER WATER; LEATHER CLEANING PREPARATIONS IN THE NATURE OF LEATHER BLEACH; LIPSTICKS; LOTIONS FOR COSMETIC PURPOSES; MAKE-UP; MAKE-UP POWDER; MAKE-UP PREPARATIONS; MAKE-UP REMOVING PREPARATIONS; MASCARA; MEDICATED SOAP; ESSENTIAL OILS, NAMELY, MINT ESSENCE; MINT FOR PERFUMERY; MOUSTACHE WAX; MOUTH WASHES, NOT FOR MEDICAL PURPOSES; MUSK; MUSTACHE WAX; NAIL CARE PREPARATIONS; NAIL POLISH; NAIL VARNISH; HAIR CARE PREPARATIONS, NAMELY, NEUTRALIZERS FOR PERMANENT WAVING; OILS FOR CLEANING PURPOSES; OILS FOR COSMETIC PURPOSES; OILS FOR TOILET PURPOSES; OILS FOR PERFUMES AND SCENTS; PAINT STRIPPING PREPARATIONS; PERFUMERY; PERFUMES; PETROLEUM JELLY FOR COSMETIC PURPOSES; POMADES FOR COSMETIC PURPOSES; POTPOURRI; NON-MEDICATED COSMETIC PREPARATIONS FOR CORRECTION OF FACE AND BODY SKIN WRINKLES AND ABNORMALITIES; COSMETIC SKIN PREPARATIONS FOR THE CORRECTION OF WRINKLES; COSMETIC SKIN PREPARATIONS, NAMELY, HYALURONIC ACID PREPARATIONS FOR USE AS A SKIN PEEL; ROSE OIL FOR COSMETIC PURPOSES; SACHETS FOR PERFUMING LINEN; ESSENTIAL OILS, NAMELY, SAFROL; SCOURING SOLUTIONS; SHAMPOOS; SHAVING PREPARATIONS; SHAVING SOAP; ANTISEPTIC SHAVING STONES; SCENTED LINEN WATER; SKIN WHITENING CREAMS; SOAP; SOAP FOR FOOT PERSPIRATION; SUNSCREEN PREPARATIONS; SUN-TANNING PREPARATIONS; COTTON SWABS FOR COSMETIC PURPOSES; TALCUM POWDER, FOR TOILET USE; ESSENTIAL OILS, NAMELY, TERPENES; TISSUES IMPREGNATED WITH COSMETIC LOTIONS; NON-MEDICATED TOILETRIES; TOILET WATER; VARNISH-REMOVING PREPARATIONS; WAVING PREPARATIONS FOR THE HAIR; WAXES FOR LEATHER (U.S. CLS. 1, 4, 6, 50, 51 AND 52).

**CLASS 5—PHARMACEUTICALS**

FOR ABSORBENT COTTON AND WADDING FOR MEDICAL PURPOSES; ADDITIVES TO FODDER FOR MEDICAL PURPOSES; ADJUTANTS FOR MEDICAL PURPOSES; ALBUMINOUS MILK FOR MEDICAL PURPOSES; ALBUMINOUS FOODSTUFFS FOR MEDICAL PURPOSES; ALUMINOUS PREPARATIONS FOR MEDICAL PURPOSES; ANALGESICS; ANTISEPTIC COTTON FOR MEDICAL PURPOSES; ANTISEPTICS; APPETITE SUPPRESSANTS FOR MEDICAL PURPOSES; ASEPTIC COTTON FOR MEDICAL PURPOSES; BACTERIAL PREPARATIONS FOR MEDICAL AND VETERINARY USE; BACTERIOLOGICAL PREPARATIONS FOR MEDICAL AND VETERINARY USE; BALMS FOR MEDICAL PURPOSES; BALSAMIC PREPARATIONS FOR MEDICAL PURPOSES; MEDICATED BATH PREPARATIONS; BATH SALTS FOR MEDICAL PURPOSES; CAMPHOR FOR MEDICAL PURPOSES; MEDICAL PREPARATIONS FOR THE TREATMENT OF CHILBLAIN; COD LIVER OIL; COTTON FOR MEDICAL PURPOSES; DENTAL LACQUER; AIR DEODORANT; CAR DEODORANT; DEODORANTS FOR CLOTHING OR TEXTILES; DISINFECTING DETERGENTS FOR MEDICAL PURPOSES; DIETETIC BEVERAGES ADAPTED FOR MEDICAL PURPOSES; DIETETIC FOOD PREPARATIONS ADAPTED FOR MEDICAL PURPOSES; DIETETIC FOODS ADAPTED FOR MEDICAL PURPOSES; DIETETIC SUBSTANCES ADAPTED FOR MEDICAL USE; DISINFECTANTS FOR HYGIENE PURPOSES; MEDICAL AND SURGICAL DRESSINGS; ENZYME PREPARATIONS FOR MEDICAL PURPOSES; ENZYMES FOR MEDICAL PURPOSES; EYE-WASH; FERMENTS FOR PHARMACEUTICAL PURPOSES; FOOD FOR BABIES; FROSTBITE SALVE FOR PHARMACEUTICAL PURPOSES; FUMIGANTS, NAMELY, FUMIGATING STICKS; GELATIN CAPSULES SOLD EMPTY FOR PHARMACEUTICALS; GERMICIDES; GLYCERINE FOR MEDICAL PURPOSES; GREASES FOR MEDICAL PURPOSES; HERBS TEAS FOR MEDICINAL PURPOSES; HORMONES FOR MEDICAL PURPOSES; HYALURONIC ACID FOR MEDICAL PURPOSES; HYDROGEN PEROXIDE FOR MEDICAL PURPOSES; HYGIENIC PREPARATIONS FOR MEDICAL PURPOSES; LINIMENTS; PHARMACEUTICAL SKIN LOTIONS; MEDICAL PREPARATIONS FOR WEIGHT LOSS; MEDICINAL HAIR GROWTH PREPARATIONS; MEDICINAL HERBS; HERBAL MUD PACKS FOR THERAPEUTIC PURPOSES; CASTOR OIL; MEDICINAL ROOTS; MEDICINAL TEA; MILK FERMENTS FOR PHARMACEUTICAL PURPOSES; MILK OF ALMONDS FOR PHARMACEUTICAL PURPOSES; MINERAL FOOD-SUPPLEMENTS; MINERAL WATER FOR MEDICAL PURPOSES; MINERAL WATER SALTS FOR MEDICAL PURPOSES; MOUTHWASHES FOR MEDICAL PURPOSES; MUD FOR MUD BATHS FOR THERAPEUTIC PURPOSES; NUTRITIONAL ADDITIVES FOR MEDICAL PURPOSES; OXYGEN FOR MEDICAL USE, NAMELY, OXYGEN BATHS; PETROLEUM JELLY FOR MEDICAL PURPOSES; PHARMACEUTICAL PREPARATIONS FOR SKIN CARE; PHARMACEUTICAL PREPARATIONS FOR TREATING DANDRUFF; MEDICAL PLASTERS; POMADES FOR MEDICAL PURPOSES; BURN DRESSINGS; PHARMACEUTICAL PREPARATIONS FOR THE TREATMENT OF BURNS; WEIGHT REDUCING TEA FOR MEDICAL PURPOSES; MEDICATED REMEDIES FOR FOOT PERSPIRATION; MEDICATED REMEDIES FOR PERSPIRATION; ROYAL JELLY FOR MEDICAL PURPOSES; SODIUM SALTS FOR MEDICAL PURPOSES; BATH SALTS FOR MEDICINAL MINERAL WATER BATHS; SEA WATER FOR MEDICINAL BATHING; MEDICATED SERUMS FOR THE TREATMENT OF HAIR, SKIN AND LIPS; MEDICATED SUNBURN OINTMENTS; SUNBURN PREPARATIONS FOR PHARMACEUTICAL PURPOSES; THERAPEUTIC MEDICATED BATH PREPARATIONS; VITAMIN PREPARATIONS; WADDING FOR MEDICAL PURPOSES, NAMELY, WOUND DRESSING; YEAST FOR PHARMACEUTICAL PURPOSES (U.S. CLS. 6, 18, 44, 46, 51 AND 52).

DANIEL CAPSHAW, EXAMINING ATTORNEY

SN 79-085,473. MONDO SPA, ITALY, FILED 12-2-2009.



PRIORITY DATE OF 11-11-2009 IS CLAIMED.  
OWNER OF INTERNATIONAL REGISTRATION 1046097  
DATED 12-2-2009, EXPIRES 12-2-2019.

THE MARK CONSISTS OF FIVE FILLED FISH EYE LENS SHAPES AND REPRESENTS THE MERIDIAN OR LINE OF LONGITUDE DISPLAYED IN A ROW.

**CLASS 12—VEHICLES**

FOR BOATS (U.S. CLS. 19, 21, 23, 31, 35 AND 44).

**CLASS 19—NON-METALLIC BUILDING MATERIALS**

FOR FLOOR COVERINGS FOR BUILDINGS AND SPORTS FIELD; INDOOR AND OUTDOOR RUNNING TRACK AND PLAYING FIELD SURFACES MADE OF POLYURETHANE; SPORTING FLOORINGS TO BE PLACED ON EXISTING INDOOR AND OUTDOOR FLOORS; WOODEN FLOORINGS; FLOOR PARQUET; WOOD PAYERS, BOTH FOR CIVIL AND SPORT USE; CERAMIC TILES; ROOF COVERINGS, NOT OF METAL; PLASTIC BOARD FOR CONSTRUCTION (U.S. CLS. 1, 12, 33 AND 50).

**CLASS 27—FLOOR COVERINGS**

FOR FLOOR COVERING FOR INDOOR AND OUTDOOR USE; FLOOR COVERING MATS FOR USE IN SPORTING ACTIVITIES; ARTIFICIAL TURF FOR CIVIL AND SPORTS USE; GYMNASIUM MATS; RUBBER FLOOR MATS (U.S. CLS. 19, 20, 37, 42 AND 50).

**CLASS 28—TOYS AND SPORTING GOODS**

FOR BALLS OF ALL KINDS FOR SPORTS AND PLAY USE; RUBBER TOYS, NAMELY, INFLATABLE THIN RUBBER TOYS, RUBBER ACTION BALLS, RUBBER BALLS, RUBBER BASEBALLS, AND RUBBER CHARACTER TOYS; TOY SETS, NAMELY, TOY CONSTRUCTION SETS, TOY HOOP SETS, TOY MODEL TRAIN SETS, AND TOYS SETS OF CARPENTERS' TOOLS; PLASTIC TOYS, NAMELY, CLOCK TOYS OF PLASTIC, MODELED PLASTIC TOY FIGURINES, PLASTIC CHARACTER TOYS, AND PLASTIC TOY HOOPS; BOARD GAMES; PLASTIC SURF BOARDS FOR PLAY USE; SWIMMING POOLS (U.S. CLS. 22, 23, 38 AND 50).

WARREN L. OLANDRIA, EXAMINING ATTORNEY

SN 79-085,507. MDP DEVELOPPEMENT, FRANCE, FILED 7-2-2010.

## MEZZO DI PASTA

THE MARK CONSISTS OF STANDARD CHARACTERS WITHOUT CLAIM TO ANY PARTICULAR FONT, STYLE, SIZE, OR COLOR.

OWNER OF INTERNATIONAL REGISTRATION 1046205 DATED 7-2-2010, EXPIRES 7-2-2020.

NO CLAIM IS MADE TO THE EXCLUSIVE RIGHT TO USE "PASTA", APART FROM THE MARK AS SHOWN. THE ENGLISH TRANSLATION OF THE FOREIGN WORD(S) IN THE MARK IS: "MIDDLE OF PASTA".

### CLASS 30—STAPLE FOODS

FOR FLOUR AND CEREAL PREPARATIONS, NAMELY, BREAKFAST CEREALS, CEREAL-BASED SNACK FOODS, PASTA, PROCESSED CEREALS; CONDIMENTS IN THE NATURE OF PIZZA SAUCE, SALAD SAUCE, HOT SAUCE, PASTA SAUCE; PASTRY AND CONFECTIONERY, NAMELY, CONFECTIONERY MADE OF SUGAR; EDIBLE ICES; SANDWICHES; PIZZAS (U.S. CL. 46).

### CLASS 43—HOTEL AND RESTAURANT SERVICES

FOR SERVICES FOR PROVIDING FOOD AND DRINK, BAR SERVICES, FOOD AND DRINK CATERING, HOTELS (U.S. CLS. 100 AND 101).

DOUGLAS LEE, EXAMINING ATTORNEY

SN 79-085,856. BENJAMIN ERISOGLU, FRANCE, FILED 6-22-2010.

## BEN TOUCH

THE MARK CONSISTS OF STANDARD CHARACTERS WITHOUT CLAIM TO ANY PARTICULAR FONT, STYLE, SIZE, OR COLOR.

PRIORITY DATE OF 12-28-2009 IS CLAIMED.

OWNER OF INTERNATIONAL REGISTRATION 1047050 DATED 6-22-2010, EXPIRES 6-22-2020.

THE NAME "BEN TOUCH" DOES NOT IDENTIFY ANY KNOWN LIVING INDIVIDUAL.

### CLASS 1—CHEMICALS

FOR CHEMICALS FOR USE IN INDUSTRY, SCIENCE AND PHOTOGRAPHY, AGRICULTURE, HORTICULTURE AND FORESTRY, NAMELY, UNPROCESSED ARTIFICIAL RESINS, AND UNPROCESSED PLASTICS (U.S. CLS. 1, 5, 6, 10, 26 AND 46).

### CLASS 2—PAINTS

FOR PAINTS, VARNISHES AND LACQUERS; PRESERVATIVES AGAINST RUST AND AGAINST THE DETERIORATION OF WOOD, NAMELY, WOOD PRESERVATIVES, WOOD PRESERVING OILS, AND ANTI-RUST GREASES AND OILS AND RUST INHIBITING COATINGS; NATURAL RESINS; RAW WOOD COATINGS IN THE NATURE OF PAINTS; WOOD PRESERVATIVES AND WOOD STAINS (U.S. CLS. 6, 11 AND 16).

### CLASS 11—ENVIRONMENTAL CONTROL APPARATUS

FOR WATER FILTRATION APPARATUS AND WATER PURIFICATION APPARATUS (U.S. CLS. 13, 21, 23, 31 AND 34).

### CLASS 18—LEATHER GOODS

FOR LEATHER AND IMITATION LEATHER; ANIMAL SKINS; TRUNKS AND TRAVELING BAGS; HAND BAGS; SHOULDER BAGS; BRIEFCASES; SCHOOL BAGS; ATTACHE CASES; WALLET(S); PURSES; AND UMBRELLAS (U.S. CLS. 1, 2, 3, 22 AND 41).

### CLASS 19—NON-METALLIC BUILDING MATERIALS

FOR PORTABLE NON-METAL BUILDINGS; NON-METAL SWIMMING POOLS; NON-METALLIC RIGID PIPES FOR BUILDING SWIMMING POOLS; BUILDING TIMBER; AND WOOD PANELING (U.S. CLS. 1, 12, 33 AND 50).

### CLASS 25—CLOTHING

FOR CLOTHING, NAMELY, SHIRTS, PANTS, COATS, DRESSES; FOOTWEAR; HATS AND CAPS; SOCKS; SLIPPERS; BEACH, SKI AND SPORTS FOOTWEAR; AND UNDERWEAR (U.S. CLS. 22 AND 39).

### CLASS 35—ADVERTISING AND BUSINESS

FOR ADVERTISING; BUSINESS MANAGEMENT; BUSINESS ADMINISTRATION; OFFICE FUNCTIONS; DIRECT MAIL ADVERTISING; ARRANGING NEWSPAPER SUBSCRIPTIONS FOR OTHERS; BUSINESS MANAGEMENT AND ORGANIZATION CONSULTANCY; BOOK-KEEPING; DOCUMENT REPRODUCTION; EMPLOYMENT AGENCIES; COMPUTERIZED FILE MANAGEMENT; ORGANIZATION OF EXHIBITIONS FOR COMMERCIAL OR ADVERTISING PURPOSES; ONLINE ADVERTISING ON A COMPUTER NETWORK; RENTAL OF ADVERTISING TIME ON COMMUNICATION MEDIA; PUBLICATION OF PUBLICITY TEXTS; RENTAL OF ADVERTISING SPACE; DISSEMINATION OF ADVERTISING MATTER; PUBLIC RELATIONS (U.S. CLS. 100, 101 AND 102).

### CLASS 36—INSURANCE AND FINANCIAL

FOR PROVIDING FINANCIAL ADVICE ON HOME LOANS; HOUSING AGENT SERVICES; CONSULTING AND INFORMATION CONCERNING INSURANCE IN THE FIELD OF HOME LOANS; BANKING; REAL ESTATE AGENCY SERVICES; REAL ESTATE BROKERAGE; REAL ESTATE CONSULTATION; SAVINGS BANK SERVICES; REAL ESTATE APPRAISALS AND VALUATION; REAL ESTATE MANAGEMENT; FINANCING SERVICES; FINANCIAL ANALYSIS; FINANCIAL EVALUATION OF ASSETS; MUTUAL FUNDS AND CAPITAL INVESTMENT; FINANCIAL CONSULTANCY; FINANCIAL EVALUATIONS IN THE FIELDS OF INSURANCE, BANKING AND REAL ESTATE; AND CAPITAL INVESTMENT SERVICES (U.S. CLS. 100, 101 AND 102).

### CLASS 37—CONSTRUCTION AND REPAIR

FOR CONSTRUCTION OF PERMANENT BUILDINGS, HIGHWAYS AND BRIDGES; PROVIDING CONSTRUCTION INFORMATION, NAMELY, INFORMATION RELATING TO BUILDING, HIGHWAY AND BRIDGE CONSTRUCTION; BUILDING CONSTRUCTION SUPERVISION; MASONRY SERVICES; ROOFING SERVICES; BUILDING SEALING; CLEANING OF BUILDING INTERIORS AND EXTERIORS; WINDOW CLEANING; REFURBISHMENT OF BUILDINGS; CONSTRUCTION AND REPAIR OF SWIMMING POOLS; PLUMBING; ELECTRICAL SERVICES, NAMELY, ELECTRICAL CONTRACTING, ELECTRICAL REPAIRS, MAINTENANCE AND INSTALLATION OF ELECTRICAL WIRING, OUTLETS, LIGHT FIXTURES AND ELECTRICAL PANELS; GENERAL BUILDING MAINTENANCE SERVICES; MAINTENANCE OF SWIMMING POOLS, SPAS, COVERS AND EQUIPMENT FOR SWIMMING POOLS (U.S. CLS. 100, 103 AND 106).

**CLASS 41—EDUCATION AND ENTERTAINMENT**

FOR PROVIDING OF TRAINING IN THE FIELDS OF BUSINESS AND BUILDING CONSTRUCTION AND MAINTENANCE; PUBLICATION OF BOOKS, REVIEWS, NEWSPAPERS; ARRANGING AND CONDUCTING COLLOQUIUMS AND TRAINING WORKSHOPS IN THE FIELD OF BUILDING CONSTRUCTION AND MAINTENANCE; INTERVIEWS FOR DEFINING OCCUPATIONAL TRAINING PATHS, NAMELY, CAREER GUIDANCE; AND CONSULTING IN TRAINING IN THE FIELDS OF BUSINESS AND BUILDING CONSTRUCTION AND MAINTENANCE (U.S. CLS. 100, 101 AND 107).

**CLASS 43—HOTEL AND RESTAURANT SERVICES**

FOR SERVICES FOR PROVIDING FOOD AND DRINK; TEMPORARY ACCOMMODATION; BAR SERVICES; FOOD AND DRINK CATERING; HOTELS; TEMPORARY ACCOMMODATION RESERVATIONS (U.S. CLS. 100 AND 101).

APRIL HESIK, EXAMINING ATTORNEY

**CLASS 41—EDUCATION AND ENTERTAINMENT**

FOR TEACHING AND TRAINING IN THE FIELDS OF BUSINESS, INDUSTRY AND INFORMATION TECHNOLOGY; CULTURAL ACTIVITIES, NAMELY, ORGANIZING CULTURAL AND ARTS EVENTS; PROVISION OF TRAINING SERVICES, NAMELY, CONDUCTING EDUCATIONAL WORKSHOPS AND SEMINARS FOR COMPANIES IN THE FIELDS OF BUSINESS, INDUSTRY AND INFORMATION TECHNOLOGY (U.S. CLS. 100, 101 AND 107).

**CLASS 42—SCIENTIFIC AND COMPUTER SERVICES**

FOR SCIENTIFIC RESEARCH AND DEVELOPMENT; TECHNICAL SUPPORT SERVICES FOR BUSINESSES, NAMELY, TECHNICAL ADVICE RELATED TO THE INSTALLATION OF SOFTWARE AND INSTALLATION OF COMPUTERS; INDUSTRIAL ANALYSIS AND RESEARCH SERVICES, NAMELY, RESEARCH IN THE FIELD OF CIVIL ENGINEERING (U.S. CLS. 100 AND 101).

JAMES MACFARLANE, EXAMINING ATTORNEY

SN 79-086,317. AGENCIA DE SUPORT A L'EMPRESA CATALANA, SPAIN, FILED 7-9-2010.



PRIORITY DATE OF 3-5-2010 IS CLAIMED.  
OWNER OF INTERNATIONAL REGISTRATION 1048331 DATED 7-9-2010, EXPIRES 7-9-2020.  
THE COLOR(S) TEAL IS/ARE CLAIMED AS A FEATURE OF THE MARK.  
THE MARK CONSISTS OF THE WORDING "ACCIÓ COMPETITIVENESS FOR CATALONIA" IN TEAL, IN A STYLIZED FONT.  
THE WORDING "ACCIÓ" HAS NO MEANING IN A FOREIGN LANGUAGE.

**CLASS 35—ADVERTISING AND BUSINESS**

FOR ADVERTISEMENT SERVICES; BUSINESS PLANNING, BUSINESS MANAGEMENT AND GUIDANCE SERVICES IN THE NATURE OF BUSINESS ADVICE, ALL FOR COMPANIES AND BUSINESSES; BUSINESS ORGANIZATION CONSULTING SERVICES; MARKET ANALYSIS; SALES PROMOTION FOR OTHERS (U.S. CLS. 100, 101 AND 102).

**CLASS 36—INSURANCE AND FINANCIAL**

FOR FINANCIAL SERVICES, NAMELY, FINANCIAL ADVICE AND CONSULTANCY SERVICES, FINANCIAL ADVISORY AND CONSULTANCY SERVICES, NAMELY, THE CREATION OF PERSONALIZED STRATEGIES TO ACHIEVE FINANCIAL INDEPENDENCE, FINANCIAL ANALYSIS AND CONSULTATION, FINANCIAL CONSULTING SERVICES, NAMELY, EXPERT ANALYSIS IN FINANCE, FINANCIAL EXCHANGE, FINANCIAL PORTFOLIO ANALYSIS SERVICES, FINANCIAL RESEARCH, FINANCIAL VALUATIONS; FINANCIAL ASSESSMENTS (U.S. CLS. 100, 101 AND 102).

SN 79-086,389. MAG. CLAUDIA KOWATSCH, AUSTRIA, FILED 1-27-2010.

# AMOREX

THE MARK CONSISTS OF STANDARD CHARACTERS WITHOUT CLAIM TO ANY PARTICULAR FONT, STYLE, SIZE, OR COLOR.

PRIORITY DATE OF 7-31-2009 IS CLAIMED.  
OWNER OF INTERNATIONAL REGISTRATION 1048487 DATED 1-27-2010, EXPIRES 1-27-2020.  
THE WORDING "AMOREX" HAS NO MEANING IN A FOREIGN LANGUAGE.

**CLASS 5—PHARMACEUTICALS**

FOR PHARMACEUTICAL PREPARATIONS FOR THE TREATMENT OF STRESS, ROMANTIC STRESS DISORDER, EMOTIONAL STRESS, PHYSICAL STRESS, DEPRESSION, SADNESS, MOOD-SWINGS, AGGRESSION, ANXIETY, FATIGUE, LOVE SICKNESS, INSOMNIA, LACK OF CONCENTRATION, ERECTILE DYSFUNCTION, SEXUAL DISORDER; AND OTHER PREPARATIONS FOR MEDICAL PURPOSES, NAMELY, PREPARATIONS FOR REGENERATION, ANTIDEPRESSANTS, PREPARATIONS TO IMPROVE RELAXATION, DECREASE PHYSICAL AND MENTAL TENSION, IMPROVE THE PSYCHO EMOTIONAL STATE, INFLUENCE FEELINGS OF LOVE, INFLUENCE FEELINGS OF BONDING, MEDICAL HERBAL PREPARATIONS; PHARMACEUTICAL PREPARATIONS FOR THE TREATMENT OF STRESS, ROMANTIC STRESS, EMOTIONAL STRESS, PHYSICAL STRESS, DEPRESSION, TENSION, SADNESS, MOOD-SWINGS, ANXIETY, FATIGUE, LOVE SICKNESS, INSOMNIA, LACK OF CONCENTRATION, ERECTILE DYSFUNCTION, LACK OF SEXUAL INTEREST IN FORM OF TABLETS, DRAGEES, CAPSULES, GRANULE, POWDERS, TEAS, SPRAYS, AS SOLUTIONS AND JUICES; SANITARY PREPARATIONS FOR MEDICAL USE; DIETETIC FOODS AND BEVERAGES ADAPTED FOR MEDICAL USE; PLASTERS FOR MEDICAL PURPOSES; MATERIALS FOR DRESSINGS, NAMELY, GAUZE FOR DRESSINGS AND BANDAGES FOR DRESSINGS; MEDICAL TRANSFERMAL PLASTERS; PHARMACEUTICAL AND MEDICAL PREPARATIONS AGAINST DEPRESSION, DEPRESSIVE MOODS, MOOD SWINGS AND EMOTIONAL DISTRESS; NUTRITIONAL ADDITIVES FOR MEDICAL PURPOSES FOR USE IN FOODS AND DIETARY SUPPLEMENTS FOR HUMAN CONSUMPTION; SANITARY PREPARATIONS FOR PERSONAL USE, NAMELY, SPRAY SANITIZER FOR PERSONAL USE (U.S. CLS. 6, 18, 44, 46, 51 AND 52).

**CLASS 30—STAPLE FOODS**

FOR COFFEE, TEA, COCOA, SUGAR, RICE, TAPIOCA, STARCH, SAGO, ARTIFICIAL COFFEE; FLOUR AND PREPARATIONS MADE FROM CEREALS, NAMELY, BISCUITS, TARTS AND CAKES; BREAD, PASTRY AND CONFECTIONERY MADE OF SUGAR, FLOUR, TAPIOCA; EDIBLE ICES; HONEY, TREACLE; YEAST; BAKING-POWDER; SALT; MUSTARD; VINEGAR; SAUCES USED AS CONDIMENTS; SPICES; ICE; NUTRITIONAL ADDITIVES AND FOOD SUPPLEMENT, NOT FOR MEDICAL PURPOSE, PREDOMINANTLY CONSISTING OF MICRO CRYSTALLINE CELLULOSE FOR NUTRITIONAL PURPOSES, DEXTROSE, PLANT POWDER, PLANT EXTRACT, LEGUMINOUS FLOUR, LEGUMINOUS PREPARATIONS, NAMELY, THICKENING AGENTS FOR USE IN COOKING, BINDING AND FILLING AGENTS FOR USE IN FOOD PREPARATIONS AND FOOD SUPPLEMENTS, NOT FOR MEDICAL USE (U.S. CL. 46).

KATHERINE M. DUBRAY, EXAMINING ATTORNEY

SN 79-086,404. DR. HERMANN GEUPEL, OBERHACHING, FED REP GERMANY, FILED 8-3-2010.

# MindCash

THE MARK CONSISTS OF STANDARD CHARACTERS WITHOUT CLAIM TO ANY PARTICULAR FONT, STYLE, SIZE, OR COLOR.

PRIORITY DATE OF 2-11-2010 IS CLAIMED.  
OWNER OF INTERNATIONAL REGISTRATION 1048538 DATED 8-3-2010, EXPIRES 8-3-2020.

**CLASS 35—ADVERTISING AND BUSINESS**

FOR COMPILATION, SYSTEMATIZATION, UPDATING, AND MANAGEMENT OF INFORMATION IN COMPUTER DATABASES (U.S. CLS. 100, 101 AND 102).

**CLASS 38—COMMUNICATION**

FOR TELECOMMUNICATIONS BY MEANS OF PLATFORMS AND PORTALS ON THE INTERNET, NAMELY, PROVIDING TELECOMMUNICATION CONNECTIONS TO DATABASES; PROVIDING ACCESS TO DATABASES (U.S. CLS. 100, 101 AND 104).

**CLASS 42—SCIENTIFIC AND COMPUTER SERVICES**

FOR ONLINE TECHNICAL AND SCIENTIFIC CONSULTANCY IN THE FIELDS OF BIOCHEMICAL RESEARCH AND DEVELOPMENT, CHEMICAL RESEARCH, ENGINEERING, PHYSICS, INFORMATION TECHNOLOGY, TELECOMMUNICATION TECHNOLOGY, MEDICAL RESEARCH, FOOD RESEARCH, RESEARCH AND DEVELOPMENT IN THE PHARMACEUTICAL AND BIOTECHNOLOGY FIELDS, RESEARCH AND DEVELOPMENT OF NEW PRODUCTS; DEVELOPMENT OF SOFTWARE FOR DATABASES AND ONLINE SERVICES; PROVIDING AN ONLINE SEARCHABLE DATABASE IN THE FIELDS OF BIOCHEMICAL RESEARCH AND DEVELOPMENT, CHEMICAL RESEARCH, ENGINEERING, PHYSICS, INFORMATION TECHNOLOGY, TELECOMMUNICATION TECHNOLOGY, MEDICAL RESEARCH, FOOD RESEARCH, RESEARCH AND DEVELOPMENT IN THE PHARMACEUTICAL AND BIOTECHNOLOGY FIELDS, RESEARCH AND DEVELOPMENT OF NEW PRODUCTS, ARCHITECTURAL DESIGN, INTERIOR DESIGN, GRAPHIC DESIGN (U.S. CLS. 100 AND 101).

**CLASS 45—PERSONAL AND LEGAL SERVICES**

FOR ONLINE CONSULTANCY RELATING TO INTELLECTUAL PROPERTY (U.S. CLS. 100 AND 101).  
CHRISTINE MARTIN, EXAMINING ATTORNEY

SN 79-086,608. SIEMENS AUDIOLOGISCHE TECHNIK GMBH, FED REP GERMANY, FILED 8-5-2010.



PRIORITY DATE OF 2-12-2010 IS CLAIMED.  
OWNER OF INTERNATIONAL REGISTRATION 1049054 DATED 8-5-2010, EXPIRES 8-5-2020.

NO CLAIM IS MADE TO THE EXCLUSIVE RIGHT TO USE "TECHNOLOGY", APART FROM THE MARK AS SHOWN.

THE COLOR(S) BLACK, WHITE AND GRAY IS/ARE CLAIMED AS A FEATURE OF THE MARK.

THE MARK CONSISTS OF THE WORDING "BEST-SOUND TECHNOLOGY" IN STYLIZED GRAY FONT WITHIN A RECTANGULAR BUTTON SHAPED GRAY BACKGROUND WITH BLACK SHADOWING AND WHITE HIGHLIGHTING.

**CLASS 9—ELECTRICAL AND SCIENTIFIC APPARATUS**

FOR APPARATUS FOR RECORDING, TRANSMISSION, PROCESSING AND REPRODUCTION OF SOUNDS, IMAGES AND DATA; COMPUTER HARDWARE FOR STORAGE AND RETRIEVAL OF DIGITAL CONTENT, NAMELY, SIGNALS, DATA, IMAGES AND SOUND; COMPUTERS; COMPUTER PERIPHERALS; COMPUTER SOFTWARE FOR DATA PROCESSING, NAMELY, COMPUTER SOFTWARE FOR FITTING OF HEARING AIDS (U.S. CLS. 21, 23, 26, 36 AND 38).

**CLASS 10—MEDICAL APPARATUS**

FOR MEDICAL HEARING AIDS AND PARTS THEREOF (U.S. CLS. 26, 39 AND 44).

**CLASS 42—SCIENTIFIC AND COMPUTER SERVICES**

FOR PLANNING AND DESIGN OF TELECOMMUNICATIONS AND INFORMATION TECHNOLOGY COMPUTER SYSTEMS AND NETWORKS FOR OTHERS; PLANNING AND DESIGN OF DATA PROCESSING COMPUTER SYSTEMS; DESIGN, WRITING AND RENTAL OF DATA PROCESSING COMPUTER SOFTWARE (U.S. CLS. 100 AND 101).

STEVEN PEREZ, EXAMINING ATTORNEY

SN 79-087,554. CALZATURIFICIO LORI S.R.L., I-63018 PORTO SANT'ELPIDIO (AP), ITALY, FILED 8-2-2010.

# LORIBLU

THE MARK CONSISTS OF STANDARD CHARACTERS WITHOUT CLAIM TO ANY PARTICULAR FONT, STYLE, SIZE, OR COLOR.



PRIORITY DATE OF 4-19-2010 IS CLAIMED.  
OWNER OF INTERNATIONAL REGISTRATION 1051681  
DATED 8-2-2010, EXPIRES 8-2-2020.

#### CLASS 18—LEATHER GOODS

FOR ANIMAL SKINS, ATTACHE CASES, BACKPACKS, BEACH BAGS, BELT BAGS, BILLFOLDS, BOSTON BAGS, BRIEFCASES, CARRY-ON BAGS, CLUTCH PURSES, COIN PURSES, DUFFLE BAGS, EVENING HANDBAGS, GLADSTONE BAGS, HANDBAGS, LEATHER AND IMITATION LEATHER BAGS, KEY CASES, PURSES, NOT OF PRECIOUS METAL, SHOULDER BAGS, SPORTS BAGS, SUITCASES, TOTE BAGS, TRAVELLING BAGS, TRAVELLING CASES OF LEATHER, TRUNKS, UMBRELLAS, VALISES, VANITY CASES SOLD EMPTY, WALLETS, NOT OF PRECIOUS METAL (U.S. CLS. 1, 2, 3, 22 AND 41).

#### CLASS 25—CLOTHING

FOR HEADGEAR, NAMELY, CAPS AND HATS; HEADWEAR; FOOTWEAR, NAMELY, BOOTS, BOOTIES, SANDALS, SHOES, SLIPPERS AND SNEAKERS; CLOTHING, NAMELY, ANORAKS, BEACHWEAR, BELTS, BLOUSES, BLOUSONS, CARDIGANS, COATS, GLOVES, GYM SUITS, HEADWEAR, JACKETS, JEANS, JERKINS, JERSEYS, JUMPERS, KNICKERS, LEATHER BELTS, LEATHER COATS, LEATHER PANTS, LEGGINGS, LOUNGEWEAR, NECKWEAR, OVERALLS, OVERCOATS, PAJAMAS, PANTS, PULLOVERS, RAINCOATS, SHIRTS, SHORTS, SKIRTS, SLEEPWEAR, SOCKS, STOCKINGS, SUITS AND DRESSES, SUSPENDERS, SWEAT PANTS, SWEATERS, SWEAT SHIRTS, TIGHTS, TRACK SUITS, TROUSERS, T-SHIRTS, UNDERWEAR, VESTS, WAISTCOATS (U.S. CLS. 22 AND 39).

#### CLASS 35—ADVERTISING AND BUSINESS

FOR ADVERTISING SERVICES; BUSINESS MANAGEMENT; BUSINESS OPERATION, BUSINESS ADMINISTRATION AND OFFICE FUNCTIONS; PRESENTATION OF GOODS ON COMMUNICATION MEDIA FOR RETAIL PURPOSES (U.S. CLS. 100, 101 AND 102).  
EVELYN BRADLEY, EXAMINING ATTORNEY

#### CLASS 18—LEATHER GOODS

FOR ANIMAL SKINS, ATTACHE CASES, BACKPACKS, BEACH BAGS, BELT BAGS, BILLFOLDS, BOSTON BAGS, BRIEFCASES, CARRY-ON BAGS, CLUTCH PURSES, COIN PURSES, DUFFLE BAGS, EVENING HANDBAGS, GLADSTONE BAGS, HANDBAGS, LEATHER AND IMITATION LEATHER BAGS, KEY CASES, PURSES, NOT OF PRECIOUS METAL, SHOULDER BAGS, SPORTS BAGS, SUITCASES, TOTE BAGS, TRAVELLING BAGS, TRAVELLING CASES OF LEATHER, TRUNKS, UMBRELLAS, VALISES, VANITY CASES SOLD EMPTY, WALLETS, NOT OF PRECIOUS METAL (U.S. CLS. 1, 2, 3, 22 AND 41).

#### CLASS 25—CLOTHING

FOR HEADGEAR, NAMELY, CAPS AND HATS; HEADWEAR; FOOTWEAR, NAMELY, BOOTS, BOOTIES, SANDALS, SHOES, SLIPPERS AND SNEAKERS; CLOTHING, NAMELY, ANORAKS, BEACHWEAR, BELTS, BLOUSES, BLOUSONS, CARDIGANS, COATS, GLOVES, GYM SUITS, HEADWEAR, JACKETS, JEANS, JERKINS, JERSEYS, JUMPERS, KNICKERS, LEATHER BELTS, LEATHER COATS, LEATHER PANTS, LEGGINGS, LOUNGEWEAR, NECKWEAR, OVERALLS, OVERCOATS, PAJAMAS, PANTS, PULLOVERS, RAINCOATS, SHIRTS, SHORTS, SKIRTS, SLEEPWEAR, SOCKS, STOCKINGS, SUITS AND DRESSES, SUSPENDERS, SWEAT PANTS, SWEATERS, SWEAT SHIRTS, TIGHTS, TRACK SUITS, TROUSERS, T-SHIRTS, UNDERWEAR, VESTS, WAISTCOATS (U.S. CLS. 22 AND 39).

#### CLASS 35—ADVERTISING AND BUSINESS

FOR ADVERTISING SERVICES; BUSINESS MANAGEMENT; BUSINESS OPERATION, BUSINESS ADMINISTRATION AND OFFICE FUNCTIONS; PRESENTATION OF GOODS ON COMMUNICATION MEDIA FOR RETAIL PURPOSES (U.S. CLS. 100, 101 AND 102).  
EVELYN BRADLEY, EXAMINING ATTORNEY

SN 79-087,872. RECKITT BENCKISER N.V., NETHERLANDS, FILED 8-25-2010.

SN 79-087,671. CALZATURIFICIO LORI S.R.L., I-63018 PORTO SANT'ELPIDIO (FM), ITALY, FILED 8-2-2010.

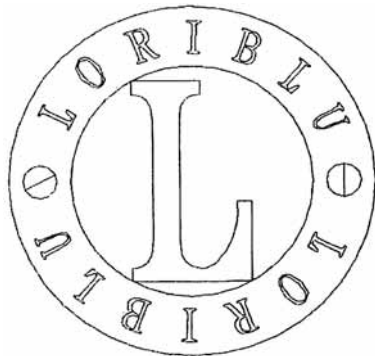

PRIORITY DATE OF 4-19-2010 IS CLAIMED.  
OWNER OF INTERNATIONAL REGISTRATION 1052016  
DATED 8-2-2010, EXPIRES 8-2-2020.

THE MARK CONSISTS OF THE WORDING "LORIBLU LORIBLU" SEPARATED BY TWO SMALL CIRCLES DIVIDED INTO TWO, ALL PLACED BETWEEN TWO LARGE CIRCLES, AND THE LETTER "L" DISPLAYED WITHIN THE INNER CIRCLE.



OWNER OF INTERNATIONAL REGISTRATION 1052560  
DATED 8-25-2010, EXPIRES 8-25-2020.

OWNER OF U.S. REG. NO. 3,857,294.  
THE COLOR(S) BLUE, GREEN, BLACK AND WHITE IS/ARE CLAIMED AS A FEATURE OF THE MARK.

THE MARK CONSISTS OF A PARTIALLY SHADED GREEN CIRCLE. THE WORDING "OUR HOME OUR PLANET" IN THE COLOR WHITE, A STYLIZED BLUE HOUSE AGAINST A WHITE BACKGROUND, AND A STYLIZED GLOBE IN THE COLORS BLUE, GREEN, BLACK, AND WHITE.

**CLASS 3—COSMETICS AND CLEANING PREPARATIONS**

FOR BLEACHING PREPARATIONS AND DETERGENTS FOR LAUNDRY USE AND DISHWASHING ; DETERGENTS FOR HOUSEHOLD USE; SOAPS; LAUNDRY STARCH; LAUNDRY BLUEING ; LAUNDRY PREPARATIONS, NAMELY, LAUNDRY BLEACH, LAUNDRY BLUEING, LAUNDRY DETERGENTS, LAUNDRY PRE-SOAK, LAUNDRY SOAP, AND LAUNDRY STARCH; LAUNDRY PREPARATIONS FOR DRY CLEANERS, NAMELY, DRY CLEANING SOLVENTS, DRY CLEANING FLUIDS AND SPOT REMOVERS; CARPET CLEANERS; SHAMPOOS; DECALCIFYING AND DESCALING PREPARATIONS FOR HOUSEHOLD PURPOSES; FABRIC SOFTENERS, STAIN REMOVING PREPARATIONS; DISHWASHING PREPARATIONS, NAMELY, DISHWASHING DETERGENTS; DISHWASHER CLEANER, FRESHENER AND DEODORISER; RINSE AGENTS FOR MACHINE DISHWASHERS ; POLISHING PREPARATIONS FOR KITCHEN AND GLASSWARE; CLEANING, POLISHING, SCOURING AND ABRASIVE PREPARATIONS; CARPET CLEANERS; SOAPS; DECALCIFYING AND DESCALING PREPARATIONS FOR DOMESTIC USE; FABRIC SOFTENERS; ALL AFOREMENTIONED GOODS WITH OR WITHOUT A DISINFECTIVE COMPONENT; BLEACHING PREPARATIONS FOR HOUSEHOLD USE; CLEANING, POLISHING, SCOURING AND ABRASIVE PREPARATIONS; DRAIN AND SINK CLEANING PREPARATIONS; LIMESCALE REMOVERS, RUST REMOVERS, DECALCIFYING AND DESCALING PREPARATIONS FOR HOUSEHOLD USE; CLEANING PREPARATIONS WHICH PREVENT THE BUILD-UP OF STAINS AND LIMESCALE; PERFUMING PREPARATIONS FOR THE ATMOSPHERE; ESSENTIAL OILS; CLOTHS, WIPES, TISSUES AND SPONGES IMPREGNATED WITH CLEANING PREPARATIONS, POLISHING PREPARATIONS, DETERGENT OR DISINFECTANT FOR HOUSEHOLD CLEANING; HAND WASHES, NAMELY, HAND CLEANING PREPARATIONS; NON-MEDICATED TOILETRIES; TALCUM POWDER; NON-MEDICATED SKIN CARE PREPARATIONS; NON-MEDICATED SKIN CARE PREPARATIONS, NAMELY, BARRIER PREPARATIONS FOR THE SKIN; SHAVING PREPARATIONS; DEODORANTS FOR PERSONAL USE; DENTIFRICES, MOUTHWASHES (U.S. CLS. 1, 4, 6, 50, 51 AND 52).

**CLASS 5—PHARMACEUTICALS**

FOR SANITARY STERILIZING PREPARATIONS; ALL PURPOSE DISINFECTANTS; DISINFECTANT PREPARATIONS FOR HYGIENE PURPOSES; ALL PURPOSE DISINFECTANT SOLUTIONS FOR USE IN WIPING SURFACES; ALL PURPOSE DISINFECTANTS FOR HOUSEHOLD USE; DISINFECTANTS FOR HYGIENE OR SANITARY PURPOSES; ALL PURPOSE DISINFECTING AGENTS AND PREPARATIONS HAVING DISINFECTING PROPERTIES; ANTI-BACTERIAL PREPARATIONS; AIR FRESHENING AND AIR PURIFYING PREPARATIONS; FUNGICIDES; PREPARATIONS OR SUBSTANCES HAVING SANITARY, DISINFECTING, AIR FRESHENING, AIR PURIFYING OR FUNGICIDAL PROPERTIES, NAMELY, FUNGICIDES FOR DOMESTIC USE; PHARMACEUTICAL PREPARATIONS FOR WOUNDS; PHARMACEUTICAL PREPARATIONS, NAMELY, ANALGESICS; PHARMACEUTICAL PREPARATIONS FOR THE RELIEF OF COLDS AND INFLUENZA; DECONGESTANTS; VETERINARY PREPARATIONS, NAMELY, ANTIOXIDANTS; SANITARY PREPARATIONS FOR MEDICAL USE; ANTISEPTIC PREPARATIONS, ANTI-BACTERIAL PREPARATIONS, NAMELY, ANTIBACTERIAL SOAP, ANTIBACTERIAL CLEANERS, ANTIBACTERIAL SPRAY, DISINFECTING PREPARATIONS, NAMELY, ALL PURPOSE DISINFECTANTS, GERMICIDES; INSECTICIDES AND MITICIDES FOR DOMESTIC USE; INSECT REPELLENTS; PREPARATIONS FOR DESTROYING AND REPELLING VERMIN; HOUSEHOLD DEODORANTS AND HOUSEHOLD DEODORIZERS (OTHER THAN FOR PERSONAL USE); ODOR NEUTRALIZERS; PREPARATIONS FOR NEUTRALIZING, CONTROLLING OR REDUCING ALLERGENS DELIVERED VIA SPRAY AND AEROSOL; CLOTHS, WIPES, TISSUES AND SPONGES IMPREGNATED WITH ANTISEPTIC FOR PERSONAL AND HOUSEHOLD USE, ANTIBACTERIAL OR DISINFECTANT PREPARATIONS FOR HYGIENE USE; BACTERICIDAL SKIN CLEANSING PREPARA-

TIONS FOR MEDICAL USE; MEDICATED TOILETRIES, NAMELY, MEDICATED SKIN CARE PREPARATIONS, MEDICATED TALCUM POWDER; MEDICAL PLASTERS, MATERIALS FOR DRESSING WOUNDS AND BURNS, NAMELY, GAUZE AND MEDICAL ADHESIVE TAPE; FIRST AID KITS (U.S. CLS. 6, 18, 44, 46, 51 AND 52).

JOHN KELLY, EXAMINING ATTORNEY

SN 79-088,021. VENERGY PTY LTD, AUSTRALIA, FILED 7-29-2010.

# VENERGY

THE MARK CONSISTS OF STANDARD CHARACTERS WITHOUT CLAIM TO ANY PARTICULAR FONT, STYLE, SIZE, OR COLOR.

PRIORITY DATE OF 6-24-2010 IS CLAIMED.

OWNER OF INTERNATIONAL REGISTRATION 1052945 DATED 7-29-2010, EXPIRES 7-29-2020.

**CLASS 9—ELECTRICAL AND SCIENTIFIC APPARATUS**

FOR APPARATUS AND INSTRUMENTS FOR CONDUCTING, SWITCHING, TRANSFORMING, ACCUMULATING, REGULATING OR CONTROLLING ELECTRICITY, NAMELY, ELECTRIC CONDUCTORS, ELECTRIC SWITCHES, ELECTRICAL TRANSFORMERS, ELECTRIC ACCUMULATORS, VOLTAGE REGULATORS FOR ELECTRIC POWER AND ELECTRICAL CONTROLLERS; SOLAR ENERGY EQUIPMENT, NAMELY, PHOTOVOLTAIC CELLS, PHOTOVOLTAIC SOLAR MODULES FOR PRODUCTION OF ELECTRICITY, AND SOLAR PANELS FOR PRODUCTION OF ELECTRICITY; EQUIPMENT FOR USE IN COLLECTING AND CONVERTING SOLAR ENERGY INTO ELECTRICITY, NAMELY, SOLAR POWERED ELECTRICITY GENERATORS AND ELECTRIC CONVERTERS; REPLACEMENT PARTS FOR THE AFOREMENTIONED GOODS (U.S. CLS. 21, 23, 26, 36 AND 38).

**CLASS 35—ADVERTISING AND BUSINESS**

FOR RETAIL AND WHOLESALE STORES FEATURING SOLAR ENERGY EQUIPMENT, INCLUDING PHOTOVOLTAIC CELLS, PHOTOVOLTAIC SOLAR MODULES, SOLAR PANELS, SOLAR POWERED ELECTRICITY GENERATORS AND CONVERTERS, INVERTERS, BATTERIES, POWER SUPPLIES; RETAIL AND WHOLESALE STORES FEATURING APPARATUS FOR GENERATING ELECTRICITY, ACCUMULATING, HEATING, LIGHTING, PUMPING AND COOLING (U.S. CLS. 100, 101 AND 102).

**CLASS 37—CONSTRUCTION AND REPAIR**

FOR INSTALLATION OF SOLAR ENERGY SYSTEMS FOR DOMESTIC, COMMERCIAL, GOVERNMENT AND SOLAR FARM APPLICATIONS; CONSTRUCTION PROJECT MANAGEMENT RELATING TO THE INSTALLATION OF SOLAR ENERGY SYSTEMS (U.S. CLS. 100, 103 AND 106).

CHRISIE B. KING, EXAMINING ATTORNEY

SN 79-088,157. CORPORATION BECS, JAPAN, FILED 8-24-2010.

# バイオナンバー

OWNER OF INTERNATIONAL REGISTRATION 1053372 DATED 8-24-2010, EXPIRES 8-24-2020.

THE ENGLISH TRANSLATION OF THE FOREIGN WORD(S) IN THE MARK IS: BIO NUMBER.

THE NON-LATIN CHARACTERS IN THE MARK TRANSLITERATE TO BAIO NAMBA AND THIS MEANS BIO NUMBER IN ENGLISH.

#### **CLASS 9—ELECTRICAL AND SCIENTIFIC APPARATUS**

FOR ELECTRONIC CALCULATORS AND THEIR STRUCTURAL AND REPLACEMENT PARTS; RECORDED VIDEO DISCS AND VIDEO TAPES FEATURING BUSINESS MANAGEMENT; ELECTRONIC BOOKS FEATURING BUSINESS MANAGEMENT RECORDED ON COMPUTER MEDIA; DOWNLOADABLE BOOKS FEATURING BUSINESS MANAGEMENT INFORMATION IN THE FIELD OF HUMAN RESOURCES; DOWNLOADABLE SOFTWARE FOR MOBILE PHONES IN THE FIELD OF BUSINESS MANAGEMENT FOR THE PURPOSE OF MAINTAINING BUSINESS AND HUMAN RESOURCES CONTACT INFORMATION AND DOCUMENTS (U.S. CLS. 21, 23, 26, 36 AND 38).

#### **CLASS 16—PAPER GOODS AND PRINTED MATTER**

FOR CATALOGUES IN THE FIELD OF BUSINESS MANAGEMENT; MAGAZINES IN THE FIELD OF BUSINESS MANAGEMENT; BOOKS IN THE FIELD OF BUSINESS MANAGEMENT; NEWSLETTERS IN THE FIELD OF BUSINESS MANAGEMENT (U.S. CLS. 2, 5, 22, 23, 29, 37, 38 AND 50).

#### **CLASS 35—ADVERTISING AND BUSINESS**

FOR PERSONNEL MANAGEMENT CONSULTANCY; PROVIDING BUSINESS ENTERPRISE INFORMATION; MARKETING RESEARCH; PROVIDING EMPLOYMENT INFORMATION (U.S. CLS. 100, 101 AND 102).

#### **CLASS 41—EDUCATION AND ENTERTAINMENT**

FOR EDUCATIONAL TRAINING ON DEVELOPING HUMAN CAPABILITY; PROVIDING EMPLOYEE TRAINING CONSULTANCY; ARRANGING, CONDUCTING AND ORGANIZATION OF SEMINARS IN THE FIELD OF BUSINESS MANAGEMENT; PUBLISHING OF ELECTRONIC PUBLICATIONS; PUBLICATION OF BOOKS; PRODUCTION OF VIDEO TAPE FILM IN THE FIELDS OF EDUCATION; PROVIDING FACILITIES FOR EDUCATIONAL TRAINING (U.S. CLS. 100, 101 AND 107).

TOBY BULLOFF, EXAMINING ATTORNEY

SN 79-088,864. TOMTOM INTERNATIONAL B.V., AMSTERDAM, NETHERLANDS, FILED 7-15-2010.



PRIORITY DATE OF 7-15-2010 IS CLAIMED.  
OWNER OF INTERNATIONAL REGISTRATION 1055334 DATED 7-15-2010, EXPIRES 7-15-2020.

THE MARK CONSISTS OF THE WORD "VIVA" WITH THE HORIZONTAL BAR IN THE LETTER "A" FORMING AN ARROW.

#### **CLASS 9—ELECTRICAL AND SCIENTIFIC APPARATUS**

FOR COMPUTER HARDWARE AND SOFTWARE TO BE USED WITH SATELLITE AND GPS NAVIGATION SYSTEMS FOR NAVIGATION PURPOSES; COMPUTER SOFTWARE FEATURING ROUTE PLANNERS AND ELECTRONIC MAPS FOR NAVIGATION AND DIGITAL DICTIONARIES FOR TRANSLATION PURPOSES; SOFTWARE FOR TRAVEL INFORMATION SYSTEMS FOR PROVIDING OR DISPLAYING TRAVEL ADVICE AND INFORMATION REGARDING PETROL STATIONS, CAR PARKS, RESTAURANTS, CAR DEALERS AND OTHER TRAVEL AND TRANSPORT RELATED INFORMATION; SOFTWARE FOR INFORMATION MANAGEMENT FOR THE TRANSPORT AND TRAFFIC SECTOR; SOFTWARE FOR VIEWING ELECTRONIC MAPS; DOWNLOADABLE ELECTRONIC MAPS; SOFTWARE FOR OPERATING ROUTE PLANNERS; ROUTE PLANNERS IN THE FORM OF HAND-HELD PERSONAL COMPUTERS; LOCATION, ORIENTATION AND NAVIGATION SYSTEMS AS WELL AS GLOBAL POSITIONING SYSTEMS (GPS) CONSISTING OF COMPUTERS, COMPUTER SOFTWARE, TRANSMITTERS, GLOBAL POSITIONING SYSTEM RECEIVERS (GPS) AND SATELLITE RECEIVERS, NETWORK LINK FOR INTERFACE SYSTEMS, PATCH CABLES, AND PARTS AND ACCESSORIES THEREFOR INCLUDING STANDS, ESPECIALLY ADAPTED COVERS, USB CLA ADAPTERS AND CHARGERS; HOLDERS FOR HAND-HELD COMPUTERS; SATELLITE AND RADIO TRANSMITTER AND RECEIVER APPARATUS, NAMELY, PROCESSORS, MOBILE TELEPHONES AND RECEIVERS; TELECOMMUNICATIONS INSTALLATIONS, NETWORKS AND APPARATUS, NAMELY, MOUNTING RACKS ESPECIALLY FITTED FOR TELECOMMUNICATIONS HARDWARE AND TELECOMMUNICATION SWITCHES; COMPUTER TERMINALS, ALL IN PARTICULAR TO BE USED WITH NAVIGATION SYSTEMS, ROUTE PLANNERS, AND DIGITAL MAPS (U.S. CLS. 21, 23, 26, 36 AND 38).

#### **CLASS 38—COMMUNICATION**

FOR SECURE AND INSECURE TELECOMMUNICATIONS SERVICES, NAMELY, TRANSMISSION AND DELIVERY OF DIGITAL DATA, PHOTOGRAPHS, AUDIO FILES, DATA, INFORMATION AND IMAGE SIGNALS BY MEANS OF COMPUTERS, CABLE RADIO AND SATELLITE TRANSFER, ALL IN PARTICULAR FOR NAVIGATION SYSTEMS, ROUTE PLANNERS AND THE USE OF ELECTRONIC MAPS; TELECOMMUNICATION SERVICES, NAMELY, PROVIDING OF TEMPORARY ACCESS TO NON-DOWNLOADABLE SOFTWARE PROVIDING MAP IMAGES AND GEOGRAPHICAL AND ITINERARY INFORMATION OBTAINED WITH THE AID OF A GLOBAL POSITIONING SYSTEM (GPS) TO ENABLE OTHERS TO DETERMINE LOCATIONS OR DIRECTIONS ACCURATELY; SECURE AND INSECURE TELECOMMUNICATION SERVICES FOR THE ELECTRONIC TRANSFER AND TEMPORARY STORAGE OF DIGITAL DATA, PHOTOGRAPHS, AUDIO FILES, DATA, INFORMATION AND IMAGE SIGNALS, ALL IN PARTICULAR FOR NAVIGATION SYSTEMS, ROUTE PLANNERS AND THE USE OF ELECTRONIC MAPS; TECHNICAL CONSULTANCY IN CONNECTION WITH THE AFOREMENTIONED SERVICES (U.S. CLS. 100, 101 AND 104).

#### **CLASS 39—TRANSPORTATION AND STORAGE**

FOR PROVIDING OF NAVIGATION AND INFORMATION SERVICES, NAMELY, INFORMATION RELATING TO TRAFFIC AND TRAFFIC JAMS; ALL THE AFOREMENTIONED SERVICES ALSO PROVIDED VIA COMMUNICATIONS NETWORK OR A CELLULAR TELEPHONE OR WIRELESS NAVIGATION SYSTEM (U.S. CLS. 100 AND 105).

MARILYN IZZI, EXAMINING ATTORNEY

SN 79-088,881. VERAZ HOLDING AB, SWEDEN, FILED 10-1-2010.



OWNER OF INTERNATIONAL REGISTRATION 0840562 DATED 9-13-2004, EXPIRES 9-13-2014.

NO CLAIM IS MADE TO THE EXCLUSIVE RIGHT TO USE "LE PAIN FRANCAIS" AND "PAINS SPECIAUX" "GATEAUX" "PATISSERIE" "SANDWICHS" "BOISSONS", APART FROM THE MARK AS SHOWN.

THE COLOR(S) DARK BLUE, LIGHT BLUE, GREY, WHITE, BLACK, RED, BROWN, AND TAN IS/ARE CLAIMED AS A FEATURE OF THE MARK.

THE MARK CONSISTS OF THE TEXT "LE PAIN FRANCAIS" OVER THE STACKED WORDS "PAINS SPECIAUX" "GATEAUX" "PATISSERIE" "SANDWICHS" "BOISSONS" WITH A DESIGN OF A BASKET OF BREADS AND TEAPOTS BETWEEN THE TEXT AND A PICTURE OF WORKERS WITH BUILDINGS IN THE BACKGROUND ABOVE THE TEXT, ALL WITHIN A BORDERED RECTANGULAR BACKGROUND. THE COLOR DARK BLUE APPEARS IN THE OUTLINE AND THE BACKGROUND AND IN THE WORDS "LE PAIN;" THE COLOR LIGHT BLUE APPEARS IN THE WORDS "PAINS SPECIAUX" "GATEAUX" "PATISSERIE" "SANDWICHS" "BOISSONS" AND IN THE SCENE OF THE WORKERS; THE COLOR GREY APPEARS IN THE CITY SCENE, IN THE BACKGROUND WITHIN THE RECTANGULAR BORDER AND IN THE TEAPOTS; THE COLOR WHITE APPEARS IN THE OUTLINE CREATING A SEPARATION BETWEEN THE BACKGROUND OF THE DESIGN AND THE BACKGROUND OF THE RECTANGLE OUTLINE OF THE MARK, IN THE SCENE WITH THE WORKERS AND BUILDINGS; AND IN THE BACKGROUND RECTANGLE CONTAINING THE WORDS "LE PAIN FRANCAIS"; THE COLOR BLACK APPEARS AS THE OUTER BORDER OF THE RECTANGULAR BACKGROUND, AND IN THE SCENE OF THE WORKERS AND BUILDINGS; THE COLOR RED APPEARS IN THE WORD "FRANCAIS"; THE COLORS BROWN AND TAN APPEAR IN THE BASKET OF BREAD AND IN THE DESIGN UNDERNEATH IT.

THE ENGLISH TRANSLATION OF "LE PAIN FRANCAIS" AND "PAINS SPECIAUX" "GATEAUX" AND "BOISSONS" IN THE MARK IS "FRENCH BREAD, SPECIAL BREADS, CAKES, DRINKS".

### CLASS 30—STAPLE FOODS

FOR COFFEE, TEA, COCOA, SUGAR, RICE, TAPIOCA, SAGO, ARTIFICIAL COFFEE, BREAD, PASTRY, EDIBLE ICES, HONEY, TREACLE, YEAST, BAKING POWDER, SALT, MUSTARD, VINEGAR, SAUCES; SPICES; ICE (U.S. CL. 46).

### CLASS 35—ADVERTISING AND BUSINESS

FOR ADVERTISING; BUSINESS MANAGEMENT; BUSINESS ADMINISTRATION; OFFICE FUNCTIONS (U.S. CLS. 100, 101 AND 102).

### CLASS 43—HOTEL AND RESTAURANT SERVICES

FOR PROVIDING OF FOOD AND DRINK; PROVIDING TEMPORARY ACCOMMODATION (U.S. CLS. 100 AND 101).

CARYN GLASSER, EXAMINING ATTORNEY

SN 79-088,921. ZHANG FENGXIA, CHINA, FILED 5-17-2010.

# HOAMGAR

THE MARK CONSISTS OF STANDARD CHARACTERS WITHOUT CLAIM TO ANY PARTICULAR FONT, STYLE, SIZE, OR COLOR.

OWNER OF INTERNATIONAL REGISTRATION 1055478 DATED 5-17-2010, EXPIRES 5-17-2020.

THE WORDING "HOAMGAR" HAS NO MEANING IN A FOREIGN LANGUAGE.

### CLASS 3—COSMETICS AND CLEANING PREPARATIONS

FOR CLEANSING MILK FOR FACE SKIN CLEANING PURPOSES; BODY LOTION; COSMETICS, NAMELY, EYE CREAM, FACE AND BODY BEAUTY CREAMS, FACE CREAMS, HAIR CREAMS, HAND CREAMS, MAKE-UP REMOVING MILK, GEL, LOTIONS AND CREAMS, NAIL VARNISHES, FOUNDATIONS, FACIAL BEAUTY MASKS, LIPSTICKS, SUNSCREENS, EYE SHADOWS, MAKE-UP POWDER, HAIR COLORANTS, HAIR NOURISHERS, FACIAL LOTION; BLUSHERS; SHAMPOO; PERFUMERY; MOUTH WASHES, NOT FOR MEDICAL PURPOSES; WASHING PREPARATIONS; PRESERVATIVES FOR LEATHER IN THE NATURE OF POLISHES; CLEANING PREPARATIONS (U.S. CLS. 1, 4, 6, 50, 51 AND 52).

### CLASS 14—JEWELRY

FOR DIAMONDS; PRECIOUS STONES; GOLD ORNAMENTS; SILVER ORNAMENTS; PLATINUM ORNAMENTS; PRECIOUS METALS, UNWROUGHT OR SEMI-WROUGHT; CARVED JADE JEWELRY; WORKS OF ART OF PRECIOUS METAL; JEWELRY CASES; WATCHES (U.S. CLS. 2, 27, 28 AND 50).

### CLASS 18—LEATHER GOODS

FOR HANDBAGS; VALISES; LEATHER STRAPS; FURSKINS; CANES; UMBRELLAS; PURSES; KEY CASES AS LEATHERWARE; ANIMAL SKINS; TRIMMINGS OF LEATHER FOR FURNITURE (U.S. CLS. 1, 2, 3, 22 AND 41).

### CLASS 25—CLOTHING

FOR CLOTHING, NAMELY, SHIRTS, SKIRT SUITS, SKIRTS, SKIRTS AND DRESSES, TROUSERS, COATS, OVERCOATS; WEDDING DRESSES; SWIMMING SUITS; GIRDLES; SHOES; HATS; HOSIERY; GLOVES; SHAWLS; NECKTIES (U.S. CLS. 22 AND 39).

### CLASS 35—ADVERTISING AND BUSINESS

FOR ADVERTISING; SALES PROMOTION FOR OTHERS, NAMELY, SALES PROMOTION FOR THIRD PARTIES; IMPORT-EXPORT AGENCIES; PROCUREMENT SERVICES FOR OTHERS IN THE NATURE OF PURCHASING GOODS AND SERVICES FOR OTHER BUSINESS, NAMELY, PROCUREMENT OF JEWELRY, CLOTHING, COSMETICS, HANDBAGS; ORGANIZATION OF TRADE FAIRS FOR COMMERCIAL OR ADVERTISING PURPOSES; FASHION SHOW EXHIBITION FOR ADVERTISING OR SALES; BUSINESS MANAGEMENT OF PERFORMING ARTISTS; RELOCATION SERVICES FOR BUSINESS; ACCOUNTING SERVICES; SECRETARIAL SERVICES (U.S. CLS. 100, 101 AND 102).

**CLASS 43—HOTEL AND RESTAURANT SERVICES**

FOR ACCOMMODATION BUREAUX, NAMELY, HOTELS, BOARDING HOUSES; HOTELS; RETIREMENT HOMES; DAY-NURSERIES; BOARDING FOR ANIMALS; RENTAL OF CHAIRS, TABLES, TABLE LINEN, GLASSWARE; HOLIDAY CAMP SERVICES IN THE NATURE OF LODGING; WINE BARS; TEA BARS (U.S. CLS. 100 AND 101).

REBECCA POVARCHUK, EXAMINING ATTORNEY

SN 79-088,933. HUMAN MED AG, FED REP GERMANY, FILED 9-16-2010.

**body-jet**

THE MARK CONSISTS OF STANDARD CHARACTERS WITHOUT CLAIM TO ANY PARTICULAR FONT, STYLE, SIZE, OR COLOR.

PRIORITY DATE OF 3-17-2010 IS CLAIMED.  
OWNER OF INTERNATIONAL REGISTRATION 1055506  
DATED 9-16-2010, EXPIRES 9-16-2020.  
OWNER OF U.S. REG. NO. 3,792,602.

**CLASS 7—MACHINERY**

FOR MACHINES FOR THE WATER JET SEPARATION OF BIOLOGICAL STRUCTURE, NOT FOR MEDICAL PURPOSES (U.S. CLS. 13, 19, 21, 23, 31, 34 AND 35).

**CLASS 10—MEDICAL APPARATUS**

FOR INSTRUMENTS AND APPARATUS FOR USE IN MEDICAL WATER JET CUTTING (U.S. CLS. 26, 39 AND 44).

**CLASS 35—ADVERTISING AND BUSINESS**

FOR ADVERTISING AND ADVERTISING SERVICES, NAMELY, DEVELOPMENT OF ADVERTISING CAMPAIGNS AND DISTRIBUTION OF ADVERTISING MATERIALS FOR OTHERS IN THE FIELDS OF MEDICAL SERVICES FOR HUMANS, NAMELY, SURGERY, AND VETERINARIAN SERVICES, NAMELY, SURGERY (U.S. CLS. 100, 101 AND 102).

**CLASS 44—MEDICAL, BEAUTY AND AGRICULTURAL SERVICES**

FOR MEDICAL SERVICES FOR HUMAN BEINGS, NAMELY, SURGERY; VETERINARY SERVICES, NAMELY, SURGERY; HEALTH AND BEAUTY CARE FOR HUMAN BEINGS AND ANIMALS (U.S. CLS. 100 AND 101).

KATHY DE JONGE, EXAMINING ATTORNEY

SN 79-089,930. WORKCUBE E-IS SISTEMLERI SANAYI VE TICARET ANONIM SIRKETI, TURKEY, FILED 8-19-2010.

**workcube**

OWNER OF INTERNATIONAL REGISTRATION 1058131  
DATED 8-19-2010, EXPIRES 8-19-2020.

**CLASS 35—ADVERTISING AND BUSINESS**

FOR ADVERTISING AGENCIES; ADVERTISING SERVICES, NAMELY, ADVERTISING BY MAIL ORDER; PROVIDING COMMERCIAL INFORMATION AND ADVICE FOR CONSUMERS; PROMOTION SERVICES; PROFESSIONAL BUSINESS CONSULTANCY; GOODS IMPORT-EXPORT AGENCIES; ORGANIZATION OF EXHIBITIONS FOR COMMERCIAL OR ADVERTISING PURPOSES; RENTAL OF OFFICE MACHINE; PROVIDING RENTAL OF EQUIPMENT FOR EXHIBITIONS FOR COMMERCIAL OR ADVERTISING PURPOSES; SALES PROMOTION FOR OTHERS; PERSONNEL RECRUITMENT; ACCOUNTING SERVICES; DRAWING UP OF STATEMENTS OF ACCOUNTS; TAX PREPARATION; PROVIDING STATISTICAL INFORMATION FOR BUSINESS OR COMMERCIAL PURPOSES; COMPUTERIZES ONLINE ORDERING SERVICES FEATURING GENERAL MERCHANDISE AND GENERAL CONSUMERS GOODS IN ORDER TO ENABLE CUSTOMERS TO EXAMINE AND PURCHASE THEM CONVENIENTLY (U.S. CLS. 100, 101 AND 102).

**CLASS 38—COMMUNICATION**

FOR BROADCASTING SERVICES; COMMUNICATION SERVICE, NAMELY, TRANSMISSION OF VOICE, AUDIO, VISUAL IMAGES AND DATA BY TELECOMMUNICATIONS NETWORKS, WIRELESS COMMUNICATION NETWORKS, THE INTERNET, INFORMATION SERVICES NETWORKS AND DATA NETWORKS; TELEGRAPH SERVICES; TELEPHONE COMMUNICATIONS SERVICES; ELECTRONIC MAIL SERVICES; COMMUNICATIONS BY COMPUTER TERMINALS; TELECOMMUNICATIONS SERVICES, NAMELY, TRANSMISSION OF VOICE, DATA, GRAPHICS, IMAGES, AUDIO AND VIDEO BY MEANS OF TELECOMMUNICATIONS NETWORKS, WIRELESS COMMUNICATION NETWORKS, AND THE INTERNET; PROVIDING INFORMATION ABOUT TELECOMMUNICATION (U.S. CLS. 100, 101 AND 104).

**CLASS 42—SCIENTIFIC AND COMPUTER SERVICES**

FOR ARCHITECTURAL CONSULTATION; COMPUTER SOFTWARE CONSULTATION; COMPUTER SOFTWARE CONSULTANCY; CONSULTANCY IN THE FIELD OF COMPUTER HARDWARE; MAINTENANCE OF COMPUTER SOFTWARE; INSTALLATION OF COMPUTER SOFTWARE; UPDATING OF COMPUTER SOFTWARE; DATA CONVERSION OF COMPUTER PROGRAMS AND DATA NOT BEING PHYSICAL CONVERSION; RENTAL OF COMPUTERS; AUTHENTICATING WORKS OF ART; BIOLOGICAL RESEARCH; RECOVERY OF COMPUTER DATA; COMPUTER PROGRAMMING (U.S. CLS. 100 AND 101).

JACLYN KIDWELL WALKER, EXAMINING ATTORNEY

SN 79-089,986. STABILIMENTO FARMACEUTICO CAV. G. TESTA S.R.L., ITALY, FILED 9-30-2010.

**TEKAF**

THE MARK CONSISTS OF STANDARD CHARACTERS WITHOUT CLAIM TO ANY PARTICULAR FONT, STYLE, SIZE, OR COLOR.

PRIORITY DATE OF 4-30-2010 IS CLAIMED.  
OWNER OF INTERNATIONAL REGISTRATION 1058278  
DATED 9-30-2010, EXPIRES 9-30-2020.

**CLASS 1—CHEMICALS**

FOR CHEMICAL PRODUCTS USED IN INDUSTRY, NAMELY, CAFFEINE AND CAFFEINE EXTRACT USED IN INDUSTRY, ADDITIVES FOR USE IN THE MANUFACTURE OF FLAVOURS IN THE FLAVOUR INDUSTRY; CHEMICAL PRODUCTS USED TO PRESERVE FOODSTUFF (U.S. CLS. 1, 5, 6, 10, 26 AND 46).

**CLASS 3—COSMETICS AND CLEANING PREPARATIONS**

FOR SOAPS; PERFUMERY, ESSENTIAL OILS, COSMETICS, NAMELY, COSMETIC PREPARATIONS FOR BODY CARE; COSMETIC PREPARATIONS FOR BEAUTY CARE; COSMETIC PREPARATIONS FOR SKIN CARE; HAIR LOTIONS; DENTIFRICES; DENTIFRICES IN THE FORM OF CHEWING GUM FOR COSMETIC PURPOSES (U.S. CLS. 1, 4, 6, 50, 51 AND 52).

**CLASS 5—PHARMACEUTICALS**

FOR DIETETIC PREPARATIONS AND SUBSTANCES, NAMELY, DIETETIC FOODS AND BEVERAGES ADAPTED FOR MEDICAL PURPOSES; FOOD SUPPLEMENTS, NAMELY, DIETETIC CAFFEINE PREPARATIONS FOR STIMULATIVE USE; CONFECTIONERY CONTAINING CAFFEINE FOR MEDICAL PURPOSES; CHEWS ENHANCED WITH CAFFEINE FOR USE AS A DIETARY SUPPLEMENT ADAPTED FOR MEDICAL USE; CHEWING GUM CONTAINING CAFFEINE FOR USE AS A DIETARY AND MEDICAL PURPOSES; FOOD SUPPLEMENTS AND DIETARY SUPPLEMENTS ADAPTED FOR MEDICAL USE; NUTRITIONAL DRINKS AND MEAL REPLACEMENT DRINKS ADAPTED FOR MEDICAL USE (U.S. CLS. 6, 18, 44, 46, 51 AND 52).

**CLASS 32—LIGHT BEVERAGES**

FOR BEERS; MINERAL AND AERATED WATERS AND OTHER NON-ALCOHOLIC DRINKS, NAMELY, ISOTONIC DRINKS, ENERGY DRINKS; SPORTS DRINKS; FRUIT DRINKS AND FRUIT JUICES; SYRUPS AND OTHER PREPARATIONS FOR MAKING BEVERAGES, NAMELY, FRUIT DRINKS, SOFT DRINKS (U.S. CLS. 45, 46 AND 48).

JOSETTE BEVERLY, EXAMINING ATTORNEY

SN 79-090.008, ASA SELECTION GMBH, FED REP GERMANY, FILED 8-25-2010.



PRIORITY DATE OF 2-26-2010 IS CLAIMED.  
OWNER OF INTERNATIONAL REGISTRATION 1058339  
DATED 8-25-2010, EXPIRES 8-25-2020.

OWNER OF U.S. REG. NO. 3,335,448.  
NO CLAIM IS MADE TO THE EXCLUSIVE RIGHT TO USE "SELECTION GERMANY", APART FROM THE MARK AS SHOWN.

THE MARK CONSISTS OF A SINGLE LINE SQUARE CARRIER WITH THE STYLIZED WORDING "ASA" IN THE TOP PORTION OF THE SQUARE, BENEATH THE WORDING "ASA" THE STYLIZED WORDING "SELECTION" APPEARS IN A SHADED QUADRILATERAL, AT THE BOTTOM OF THE SQUARE THE STYLIZED WORDING "GERMANY" APPEARS.

**CLASS 21—HOUSEWARES AND GLASS**

FOR CERAMIC HOUSEHOLD OR KITCHEN PRODUCTS, NAMELY, CERAMIC GOBLET, CERAMIC CUPS, CERAMIC MUGS, CERAMIC PLATES; CERAMIC TEA POTS; CERAMIC ESPRESSO CUPS; CERAMIC JARS; CERAMIC BOTTLES; CERAMIC PITCHER; CERAMIC BREAD BOWLS; CERAMIC FLOWER POTS, CERAMIC VASES; CERAMIC CANDLE HOLDERS; CERAMIC TEALIGHT HOLDERS; CERAMIC PLANTERS, CERAMIC FLOWER-POT COVERS, NOT OF PAPER; CERAMIC EGG CUPS, CERAMIC CRUETS, CERAMIC BEVERAGES CONTAINER, CERAMIC VEGETABLE DISHES, CERAMIC COOKING POT SETS, CERAMIC MORTARS; CERAMIC CAKE PLATTER; CERAMIC PEPPERMILLS; CERAMIC SUGAR-AND PEPPER SHAKER; CERAMIC OIL AND VINEGAR BOTTLES; CERAMIC WINE COOLER; CERAMIC TABLEWARE, OTHER THAN KNIVES, FORKS, SPOONS; CERAMIC SERVICES IN THE NATURE OF DISHES, CERAMIC TOILET PAPER HOLDERS, CERAMIC NAPKIN HOLDERS, CERAMIC COFFEE SERVICES, CERAMIC TEAPOTS, CERAMIC JUGS, CERAMIC DECANTERS, CERAMIC FRUIT CUPS, CERAMIC SALAD BOWLS, CERAMIC DRINKING VESSELS, PORCELAIN HOUSEHOLD OR KITCHEN PRODUCTS, NAMELY, PORCELAIN GOBLET, PORCELAIN CUPS; PORCELAIN MUGS; PORCELAIN THERMO MUGS; PORCELAIN PLATES; PORCELAIN TEA POTS; PORCELAIN ESPRESSO CUPS; PORCELAIN JARS; PORCELAIN BOTTLES; PORCELAIN PITCHER; PORCELAIN BREAD BOWLS; PORCELAIN FLOWER POTS; PORCELAIN PLANTERS; PORCELAIN VASES; PORCELAIN CANDLE HOLDERS; PORCELAIN TEALIGHT HOLDERS; PORCELAIN FLOWER-POT COVERS, NOT OF PAPER; PORCELAIN EGG CUPS, PORCELAIN CRUETS, PORCELAIN BEVERAGE CONTAINERS, PORCELAIN VEGETABLE DISHES, PORCELAIN COOKING POT SETS, PORCELAIN MORTARS, PORCELAIN CAKE PLATTER; PORCELAIN WINE COOLER; PORCELAIN PEPPERMILLS; PORCELAIN SUGAR-AND PEPPER SHAKER PORCELAIN OIL AND VINEGAR BOTTLES; PORCELAIN TABLEWARE, OTHER THAN KNIVES, FORKS, SPOONS; PORCELAIN SERVICES IN THE NATURE OF DISHES; PORCELAIN TOILET PAPER HOLDERS, PORCELAIN NAPKIN HOLDERS, PORCELAIN COFFEE SERVICES, PORCELAIN TEAPOTS, PORCELAIN JUGS, PORCELAIN DECANTERS, PORCELAIN FRUIT CUPS, PORCELAIN SALAD BOWLS, PORCELAIN DRINKING VESSELS (U.S. CLS. 2, 13, 23, 29, 30, 33, 40 AND 50).

**CLASS 24—FABRICS**

FOR TABLE LINEN, NOT OF PAPER; TABLE MATS FOR CARAFES, NOT OF PAPER; TABLE CLOTHS, NOT OF PAPER; TABLE RUNNER, NOT OF PAPER; PLACE MATS, NOT OF PAPER; NAPKINS OF TEXTILES; KITCHEN TOWELS, NOT OF PAPER; BARBECUE GLOVES; POT HOLDERS; APRONS, NOT OF PAPER (U.S. CLS. 42 AND 50).

**CLASS 35—ADVERTISING AND BUSINESS**

FOR RETAIL STORE SERVICES AND WHOLESALE STORE SERVICES, INCLUDING VIA THE INTERNET AND BY MAIL ORDER FEATURING THE FOLLOWING GOODS, NAMELY, HOUSEHOLD OR KITCHEN CONTAINERS, CERAMIC PRODUCTS FOR HOUSEHOLD PURPOSES, PORCELAIN PRODUCTS FOR HOUSEHOLD PURPOSES, TABLE LINEN, TABLE COVERS, TABLE RUNNERS, PLACE MATS, TABLE NAPKINS OF TEXTILE (U.S. CLS. 100, 101 AND 102).

MARILYN IZZI, EXAMINING ATTORNEY

SN 79-090,030. BAYERISCHE MOTOREN WERKE AKTIEN-GESELLSCHAFT, MÜNCHEN, FED REP GERMANY, FILED 9-28-2010.

# BMW Gran Coupe

THE MARK CONSISTS OF STANDARD CHARACTERS WITHOUT CLAIM TO ANY PARTICULAR FONT, STYLE, SIZE, OR COLOR.

PRIORITY DATE OF 4-21-2010 IS CLAIMED.

OWNER OF INTERNATIONAL REGISTRATION 1058411 DATED 9-28-2010, EXPIRES 9-28-2020.

OWNER OF U.S. REG. NOS. 611,710, 2,816,178 AND OTHERS.

NO CLAIM IS MADE TO THE EXCLUSIVE RIGHT TO USE "COUPE", APART FROM THE MARK AS SHOWN.

THE ENGLISH TRANSLATION OF "GRAN" IN THE MARK IS GRAND.

## CLASS 12—VEHICLES

FOR AUTOMOBILES (U.S. CLS. 19, 21, 23, 31, 35 AND 44).

## CLASS 28—TOYS AND SPORTING GOODS

FOR SCALE MODEL VEHICLES (U.S. CLS. 22, 23, 38 AND 50).

COLLEEN DOMBROW, EXAMINING ATTORNEY

SN 79-090,084. CAMBI AS, NORWAY, FILED 7-22-2010.

# CAMBI

THE MARK CONSISTS OF STANDARD CHARACTERS WITHOUT CLAIM TO ANY PARTICULAR FONT, STYLE, SIZE, OR COLOR.

OWNER OF INTERNATIONAL REGISTRATION 1058602 DATED 7-22-2010, EXPIRES 7-22-2020.

## CLASS 11—ENVIRONMENTAL CONTROL APPARATUS

FOR PLANTS FOR TREATMENT OF SEWAGE SLUDGE, HOUSEHOLD WASTE, AND/OR INDUSTRIAL AND AGRICULTURAL WASTES, SLUDGE AND OTHER BY-PRODUCTS; PLANTS FOR THERMAL HYDROLYSIS AND STEAM EXPLOSION OF SEWAGE SLUDGE, HOUSEHOLD WASTE, INDUSTRIAL SLUDGE, INDUSTRIAL WASTE, AGRICULTURAL WASTE AND/OR ANY OTHER ORGANIC MATERIAL SUCH AS STRAW AND WOOD; PLANTS FOR CONVERSION OF SEWAGE SLUDGE, HOUSEHOLD WASTE, AND/OR INDUSTRIAL AND AGRICULTURAL WASTE, SLUDGE AND OTHER BY-PRODUCTS TO RENEWABLE ENERGY AND BIO-GAS (U.S. CLS. 13, 21, 23, 31 AND 34).

## CLASS 37—CONSTRUCTION AND REPAIR

FOR BUILDING CONSTRUCTION, BUILDING CONSTRUCTION MANAGEMENT, BUILDING CONSTRUCTION INFORMATION, BUILDING REPAIR SERVICES, INSTALLATION AND MAINTENANCE OF COMPUTER HARDWARE (U.S. CLS. 100, 103 AND 106).

## CLASS 40—MATERIAL TREATMENT

FOR TREATMENT OF MATERIALS, NAMELY, TREATMENT OF SLUDGE FROM WASTE WATER TREATMENT PLANTS; TREATMENT OF SOLID AND LIQUID HOUSEHOLD WASTE, ORGANIC INDUSTRIAL WASTE, SEWAGE SLUDGE, FISH WASTE AND ANIMAL BY-PRODUCTS; CONVERSION OF SEWAGE SLUDGE, HOUSEHOLD WASTE, AND/OR INDUSTRIAL AND AGRICULTURAL WASTE, SLUDGE AND OTHER BY-PRODUCTS TO RENEWABLE ENERGY AND BIO-GAS; WATER TREATMENT SERVICES (U.S. CLS. 100, 103 AND 106).

## CLASS 42—SCIENTIFIC AND COMPUTER SERVICES

FOR SCIENTIFIC AND TECHNOLOGICAL SERVICES AND RESEARCH AND DESIGN RELATING THERETO IN THE FIELDS OF TREATMENT PLANTS AND REFUSE DISPOSAL PLANTS; INDUSTRIAL ANALYSIS AND RESEARCH SERVICES; PRODUCT DEVELOPMENT; INDUSTRIAL DESIGN; DESIGN AND DEVELOPMENT OF COMPUTER HARDWARE AND SOFTWARE; UPDATING AND MAINTENANCE OF COMPUTER SOFTWARE; LAND SURVEYING; DRAWING UP OF ENGINEERING DRAWINGS REGARDING CONSTRUCTION; CONDUCTING TECHNICAL FEASIBILITY STUDIES; CONSULTING SERVICES REGARDING THE DESIGN OF TREATMENT PLANTS AND REFUSE DISPOSAL PLANTS (U.S. CLS. 100 AND 101).

DAVID ELTON, EXAMINING ATTORNEY

SN 79-091,282. NEWMEDIA LIVING LIMITED, CHESHIRE, UNITED KINGDOM, FILED 10-13-2010.



PRIORITY DATE OF 8-13-2010 IS CLAIMED.  
OWNER OF INTERNATIONAL REGISTRATION 1061772 DATED 10-13-2010, EXPIRES 10-13-2020.  
THE MARK CONSISTS OF A CARTOON DESIGN OF A BUNNY RABBIT.

## CLASS 35—ADVERTISING AND BUSINESS

FOR ADVERTISING SERVICES; PROVISION OF ADVERTISING SPACE ON INTERNET WEBSITES; CLASSIFIED ADVERTISING; DISSEMINATION OF ADVERTISING FOR OTHERS VIA AN ON-LINE ELECTRONIC COMMUNICATIONS NETWORK; COMPILATION OF AN ON-LINE BUSINESS/COMMERCIAL INFORMATION DIRECTORY; BUSINESS MANAGEMENT; BUSINESS ADMINISTRATION; PROVIDING OFFICE FUNCTIONS; BUSINESS INFORMATION MANAGEMENT; ARRANGING AND CONDUCTING MARKETING PROMOTIONAL EVENTS FOR OTHERS; RETAIL STORE SERVICES AND WHOLESALE DISTRIBUTORSHIP SERVICES CONNECTED WITH THE SALE OF APPARATUS FOR RECORDING, TRANSMISSION OR REPRODUCTION OF SOUND AND/OR IMAGES, TELECOMMUNICATIONS APPARATUS AND EQUIPMENT, COMMUNICATIONS APPARATUS AND EQUIPMENT, DATA PROCESSING EQUIPMENT AND

COMPUTERS, COMPUTER HARDWARE AND FIRMWARE, COMPUTER SOFTWARE, COMPUTER GAMES EQUIPMENT, COMPUTER GAMES, MOBILE PHONE ACCESSORIES, MUSICAL RECORDINGS, CDS, DVDS, VIDEOS, SOUND RECORDINGS, VIDEO RECORDINGS, CLOTHING FOR CHILDREN, BOYS, GIRLS, MEN AND/OR WOMEN, FOOTWEAR AND HEADGEAR, EYEWEAR, SPORTING ARTICLES, SPORTING APPARATUS AND EQUIPMENT, HOROLOGICAL AND CHRONOMETRIC INSTRUMENTS, CLOCKS AND WATCHES, JEWELRY, APPARATUS FOR LIGHTING, HEATING, STEAM GENERATING, COOKING, REFRIGERATING, DRYING, VENTILATING, WASHING MACHINES, IRONS, VACUUM CLEANERS, DISH WASHERS, JUICERS, COFFEE MACHINES, TOASTERS, KITCHEN ELECTRICAL APPLIANCES, WHITE GOODS, DEODORANTS FOR PERSONAL USE, FRAGRANCES, PERFUMERY, TOILETRY PRODUCTS, BLEACHING PREPARATIONS AND OTHER SUBSTANCES FOR LAUNDRY USE, CLEANING, POLISHING, SCOURING AND ABRASIVE PREPARATIONS, SOAPS, PERFUMERY, ESSENTIAL OILS, COSMETICS, HAIR LOTIONS, BEAUTY CARE PRODUCTS AND PREPARATIONS, PAINTS, VARNISHES, LACQUERS, INDUSTRIAL OILS AND GREASES, LUBRICANTS, FUELS AND ILLUMINANTS, CANDLES AND WICKS FOR LIGHTING, MATERIAL FOR STOPPING TEETH, DENTAL WAX, DISINFECTANTS, FUNGICIDES, HERBICIDES, MACHINE TOOLS, POWER TOOLS, HAND TOOLS AND HAND OPERATED IMPLEMENTS, SCIENTIFIC, NAUTICAL, SURVEYING, PHOTOGRAPHIC, CINEMATOGRAPHIC, OPTICAL, WEIGHING, MEASURING, SIGNALING, SUPERVISION, LIFE-SAVING AND TEACHING APPARATUS AND INSTALLMENTS, VEHICLES, APPARATUS FOR LOCOMOTION BY LAND, AIR OR WATER, MUSICAL INSTRUMENTS, STANDS AND CASES ADAPTED FOR MUSICAL INSTRUMENTS, PAPER AND CARDBOARD AND GOODS MADE FROM THESE MATERIALS, STATIONERY, LEATHER AND IMITATIONS OF LEATHER, TRUNKS AND TRAVELING BAGS, HANDBAGS, RUCKSACKS, PURSES, UMBRELLAS, PARASOLS AND WALKING STICKS, WHIPS, HARNESS AND SADDLERY, FURNITURE, MIRRORS, PICTURE FRAMES, PILLOWS AND CUSHIONS; BEDDING FOR USE BY HUMAN BEINGS, HOUSEHOLD OR KITCHEN UTENSILS AND CONTAINERS, TEXTILES AND TEXTILE GOODS, CARPETS, RUGS, FLOOR COVERINGS, FOOD PRODUCTS AND FOOD AND FOODSTUFFS AND FOOD PREPARATIONS ALL FOR HUMAN CONSUMPTION, NON-ALCOHOLIC DRINKS, ALCOHOLIC DRINKS, GLASSWARE, TABLEWARE, TOBACCO AND SMOKERS' ARTICLES, PHARMACEUTICAL PRODUCTS, TENTS, CAMPING APPARATUS; BUSINESS ADVICE AND INFORMATION RELATING TO ADVERTISING, MARKETING AND RETAIL SERVICES (U.S. CLS. 100, 101 AND 102).

#### **CLASS 41—EDUCATION AND ENTERTAINMENT**

FOR PROVIDING ONLINE NON-DOWNLOADABLE PUBLICATION IN THE NATURE OF A WEBSITE RELATING TO ENTERTAINMENT, LEISURE, RECREATION, SPORT, ARTS AND CULTURE, CULTURAL ACTIVITIES; NEWS SYNDICATION REPORTING; PROVIDING NEWS IN THE NATURE OF CURRENT EVENT REPORTING, ALSO VIA THE INTERNET; PROVISION OF INFORMATION RELATING TO ENTERTAINMENT, LEISURE, RECREATION, SPORT, ARTS AND CULTURE, CULTURAL ACTIVITIES; PROVIDING INFORMATION IN THE FIELD OF PUBLISHING AND CURRENT EVENT REPORTING (U.S. CLS. 100, 101 AND 107).

#### **CLASS 45—PERSONAL AND LEGAL SERVICES**

FOR SOCIAL INTRODUCTION SERVICES; INTERNET-BASED SOCIAL INTRODUCTION SERVICES; PROVIDING INFORMATION IN THE FIELD OF SOCIAL INTRODUCTION SERVICES (U.S. CLS. 100 AND 101).

JANICE L. MCMORROW, EXAMINING ATTORNEY

---

SN 85-000,652. REZZABLE PRODUCTIONS LTD, LONDON, EC2A 4BH, UNITED KINGDOM, FILED 3-29-2010.

# REZZABLE

#### **CLASS 38—COMMUNICATION**

FOR PROVIDING ACCESS TO A WEB PORTAL; ELECTRONIC MAIL SERVICES, VOICE-MAIL AND MESSAGING SERVICES; ELECTRONIC TRANSMISSION OF DATA, NAMELY, IMAGES, GRAPHICS, SOUND TEST OR AUDIOVISUAL DATA, MESSAGES AND DOCUMENTS; DATA TRANSMISSION SERVICES; E-MAIL AND INSTANT MESSAGING SERVICES; BROADCASTING SERVICES, NAMELY, TRANSMITTING, UPLOADING, RECEIVING, AND FORWARDING ELECTRONIC MEDIA, DATA OR INFORMATION OVER THE INTERNET OR OTHER COMMUNICATIONS NETWORK; PROVIDING USER ACCESS TO THE INTERNET; NEWS AGENCY SERVICES, NAMELY, TRANSMISSION OF NEWS; TELECOMMUNICATION CONSULTATION IN THE NATURE OF TECHNICAL CONSULTING IN THE FIELD OF AUDIO, TEXT, AND VISUAL DATA TRANSMISSION AND COMMUNICATION (U.S. CLS. 100, 101 AND 104).

THE MARK CONSISTS OF STANDARD CHARACTERS WITHOUT CLAIM TO ANY PARTICULAR FONT, STYLE, SIZE, OR COLOR.

OWNER OF UNITED KINGDOM REG. NO. 2527486, DATED 9-29-2009, EXPIRES 9-29-2019.



**CLASS 9—ELECTRICAL AND SCIENTIFIC APPARATUS**

FOR COMPUTER SOFTWARE FOR TEACHING HISTORY OR CULTURE, OR FOR PROVIDING INFORMATION ABOUT HISTORIC SITES, ARTEFACTS, MUSEUMS, PEOPLE, PUBLICATIONS AND HISTORIC EVENTS; COMPUTER GAME SOFTWARE; VIRTUAL REALITY GAME SOFTWARE; ENTERTAINMENT SOFTWARE, NAMELY, COMPUTER SOFTWARE FEATURING MULTI-PLAYER ACCESS TO AN ONLINE GAME ENVIRONMENT; ELECTRONIC PUBLICATIONS, NAMELY, BOOKS, MAGAZINES, MANUALS FEATURING INFORMATION RELATING TO HISTORY, CULTURE, HISTORIC SITES, ARTEFACTS, MUSEUMS, PEOPLE, PUBLICATIONS AND HISTORIC EVENTS BEING RECORDED ON COMPUTER MEDIA AND BOOKS, MAGAZINES, MANUALS FEATURING INFORMATION RELATING TO HISTORY, CULTURE, HISTORIC SITES, ARTEFACTS, MUSEUMS, PEOPLE, PUBLICATIONS AND HISTORIC EVENTS BEING DOWNLOADABLE FROM THE INTERNET; APPARATUS FOR RECORDING, TRANSMISSION OR REPRODUCTION OF SOUND OR IMAGES; BLANK MAGNETIC DATA CARRIERS; PRERECORDED MAGNETIC DATA CARRIERS FEATURING INFORMATION RELATING TO HISTORY, CULTURE, HISTORIC SITES, ARTEFACTS, MUSEUMS, PEOPLE, PUBLICATIONS AND HISTORIC EVENTS; PRERECORDED DIGITAL VIDEO DISCS, CD-ROMS, DVDS FEATURING INFORMATION RELATING TO HISTORY, CULTURE, HISTORIC SITES, ARTEFACTS, MUSEUMS, PEOPLE, PUBLICATIONS AND HISTORIC EVENTS; AUDIO AND VIDEO RECORDINGS FEATURING INFORMATION RELATING TO HISTORY, CULTURE, HISTORIC SITES, ARTEFACTS, MUSEUMS, PEOPLE, PUBLICATIONS AND HISTORIC EVENTS; DOWNLOADABLE ELECTRONIC DATA FILES AND DATABASES, NAMELY, BUSINESS AND TAX FORMS, FOR USE WITH COMPUTER SOFTWARE; ELECTRONIC DATABASE IN THE FIELD OF INFORMATION RELATING TO HISTORY, CULTURE, HISTORIC SITES, ARTEFACTS, MUSEUMS, PEOPLE, PUBLICATIONS AND HISTORIC EVENTS, RECORDED ON COMPUTER MEDIA; COMPUTER SOFTWARE FOR APPLICATION AND DATABASE INTEGRATION (U.S. CLS. 21, 23, 26, 36 AND 38).

**CLASS 16—PAPER GOODS AND PRINTED MATTER**

FOR PRINTED MATTER, NAMELY, BOOKS, MAGAZINES, MANUALS, HAND-OUTS, WORKBOOKS FEATURING INFORMATION RELATING TO HISTORY, CULTURE, HISTORIC SITES, ARTEFACTS, MUSEUMS, PEOPLE, PUBLICATIONS AND HISTORIC EVENTS; EDUCATIONAL PUBLICATIONS, NAMELY, BOOKS, MAGAZINES, MANUALS, HAND-OUTS, WORKBOOKS FEATURING INFORMATION RELATING TO HISTORY, CULTURE, HISTORIC SITES, ARTEFACTS, MUSEUMS, PEOPLE, PUBLICATIONS AND HISTORIC EVENTS; LEAFLETS, CATALOGUES, BROCHURES FEATURING INFORMATION RELATING TO HISTORY, CULTURE, HISTORIC SITES, ARTEFACTS, MUSEUMS, PEOPLE, PUBLICATIONS AND HISTORIC EVENTS; A SERIES OF WRITTEN ARTICLES FEATURING INFORMATION RELATING TO HISTORY, CULTURE, HISTORIC SITES, ARTEFACTS, MUSEUMS, PEOPLE, PUBLICATIONS AND HISTORIC EVENTS; CALENDARS; MAPS; PRINTED INSTRUCTIONAL, EDUCATIONAL AND TEACHING MATERIALS FEATURING INFORMATION RELATING TO HISTORY, CULTURE, HISTORIC SITES, ARTEFACTS, MUSEUMS, PEOPLE, PUBLICATIONS AND HISTORIC EVENTS; PHOTOGRAPHS; STATIONERY; WRITING AND DRAWING INSTRUMENTS (U.S. CLS. 2, 5, 22, 23, 29, 37, 38 AND 50).

**CLASS 25—CLOTHING**

FOR CLOTHING, NAMELY, TROUSERS, SKIRTS, DRESSES, SHORTS, SWEATSHIRTS, SWEATERS, CARDIGANS, SHIRTS, BLOUSES, T-SHIRTS, JACKETS, COATS, GILETS, CLOAKS, NIGHTDRESSES, PAJAMAS, DRESSING GOWNS, UNDERGARMENTS, SHAWLS, SCARVES; FOOTWEAR; HEADGEAR, NAMELY, HATS, CAPS (U.S. CLS. 22 AND 39).

**CLASS 38—COMMUNICATION**

FOR COMMUNICATIONS AND TELECOMMUNICATIONS SERVICES, NAMELY, COMMUNICATIONS AND TELECOMMUNICATIONS BY COMPUTER TERMINALS, RADIO BROADCASTING, TELEVISION BROADCASTING; PROVIDING MULTIPLE-USER ACCESS TO A GLOBAL COMPUTER INFORMATION NETWORK; PROVIDING ON-LINE ELECTRONIC BULLETIN BOARDS FOR TRANSMISSION OF MESSAGES AMONG COMPUTER USERS IN THE FIELD OF GENERAL INTEREST; TELECOMMUNICATIONS SERVICES, NAMELY, PROVIDING MULTIPLE-USER ACCESS TO A GLOBAL COMPUTER INFORMATION NETWORK; PROVIDING ACCESS TO ONLINE GAME WEBSITES ON THE INTERNET; TEXT AND NUMERIC WIRELESS DIGITAL MESSAGING SERVICES IN THE FIELD OF ONLINE COMPUTER GAMES; PROVIDING ACCESS TO DATABASES; VIRTUAL CHATROOMS ESTABLISHED VIA TEXT MESSAGING; PROVIDING ONLINE FORUMS FOR TRANSMISSION OF MESSAGES AMONG COMPUTER USERS; PROVIDING ONLINE FORUMS FOR ENTERTAINMENT, EDUCATIONAL OR CULTURAL PURPOSES, NAMELY, FOR HISTORY, CULTURE, HISTORIC SITES, ARTEFACTS, MUSEUMS, PEOPLE, PUBLICATIONS AND HISTORIC EVENTS; ADVISORY, CONSULTANCY AND INFORMATION SERVICES RELATING TO ALL THE AFORESAID, NAMELY, COMMUNICATIONS AND TELECOMMUNICATIONS CONSULTATION, RADIO BROADCASTING CONSULTATION, TELEVISION BROADCASTING CONSULTATION (U.S. CLS. 100, 101 AND 104).

**CLASS 41—EDUCATION AND ENTERTAINMENT**

FOR EDUCATION, NAMELY, CLASSES AND SEMINARS IN THE FIELD OF HISTORY, CULTURE, HISTORIC SITES, ARTEFACTS, MUSEUMS, PEOPLE, PUBLICATIONS AND HISTORIC EVENTS; PROVIDING OF TRAINING SERVICES IN THE FIELD OF HISTORY, CULTURE, HISTORIC SITES, ARTEFACTS, MUSEUMS, PEOPLE, PUBLICATIONS AND HISTORIC EVENTS; ENTERTAINMENT, SPORTING AND CULTURAL ACTIVITIES, NAMELY, ORGANIZING LIVE EXHIBITIONS AND CONFERENCES IN THE FIELDS OF EDUCATION, CULTURE, SPORTS AND ENTERTAINMENT FOR NON-BUSINESS AND NON-COMMERCIAL PURPOSES; ENTERTAINMENT SERVICES, NAMELY, PROVIDING AN ONLINE COMPUTER GAME BY MEANS OF COMMUNICATIONS NETWORKS; ENTERTAINMENT SERVICES, NAMELY, PROVIDING AN ONLINE MULTI-PLAYER ELECTRONIC COMPUTER GAME; ENTERTAINMENT SERVICES, NAMELY, PROVIDING AN ONLINE COMPUTER GAME THAT MAY BE ACCESSED BY MEANS OF COMMUNICATIONS NETWORKS; ENTERTAINMENT SERVICES, NAMELY, PROVIDING VIRTUAL ENVIRONMENTS FOR CULTURAL, EDUCATIONAL, RECREATIONAL, LEISURE OR ENTERTAINMENT PURPOSES; ARRANGING EXHIBITIONS FOR ENTERTAINMENT, EDUCATIONAL OR CULTURAL PURPOSES, NAMELY, ORGANIZING LIVE EXHIBITIONS AND CONFERENCES IN THE FIELDS OF EDUCATION, CULTURE, SPORTS AND ENTERTAINMENT FOR NON-BUSINESS AND NON-COMMERCIAL PURPOSES; PROVIDING CLASSES, SEMINARS, WORKSHOPS, LECTURES IN THE FIELDS OF HISTORY, CULTURE, HISTORIC SITES, ARTEFACTS, MUSEUMS, PEOPLE, PUBLICATIONS AND HISTORIC EVENTS; ARRANGING OF QUIZZES, NAMELY, EDUCATIONAL EXAMINATION SERVICES; ADVISORY, CONSULTANCY AND INFORMATION SERVICES RELATING TO ALL THE AFORESAID, NAMELY, BUSINESS TRAINING CONSULTANCY SERVICES, CONSULTATION IN THE FIELD OF SPECIAL EVENT PLANNING FOR SOCIAL ENTERTAINMENT PURPOSES; ON-LINE JOURNALS FOR ENTERTAINMENT, EDUCATIONAL

OR CULTURAL PURPOSES, NAMELY, BLOGS FEATURING HISTORY, CULTURE, HISTORIC SITES, ARTEFACTS, MUSEUMS, PEOPLE, PUBLICATIONS AND HISTORIC EVENTS; INTERACTIVE EDUCATIONAL AND ENTERTAINMENT SERVICES, NAMELY, PROVIDING ON-LINE, NON-DOWNLOADABLE VIRTUAL GAMES FOR USE IN VIRTUAL ENVIRONMENTS CREATED FOR ENTERTAINMENT PURPOSES (U.S. CLS. 100, 101 AND 107).

#### **CLASS 42—SCIENTIFIC AND COMPUTER SERVICES**

FOR DESIGN AND DEVELOPMENT OF COMPUTER HARDWARE AND SOFTWARE; DESIGN AND DEVELOPMENT OF COMPUTER GAME SOFTWARE AND VIRTUAL REALITY SOFTWARE; COMPUTER SERVICES, NAMELY, CREATING AN ONLINE COMMUNITY FOR REGISTERED USERS TO PARTICIPATE IN DISCUSSIONS, GET FEEDBACK FROM THEIR PEERS, FORM VIRTUAL COMMUNITIES AND ENGAGE IN SOCIAL NETWORKING; REPAIR AND MAINTENANCE OF COMPUTER SOFTWARE; ADVISORY, CONSULTANCY AND INFORMATION SERVICES RELATING TO COMPUTER SOFTWARE; ADVISORY, CONSULTANCY AND INFORMATION SERVICES RELATING TO SCIENTIFIC RESEARCH IN THE FIELD OF HISTORY, CULTURE, HISTORIC SITES, ARTEFACTS, MUSEUMS, PEOPLE, PUBLICATIONS AND HISTORIC EVENTS (U.S. CLS. 100 AND 101).

MARCIE MILONE, EXAMINING ATTORNEY

#### **CLASS 9—ELECTRICAL AND SCIENTIFIC APPARATUS**

FOR COMPUTER SOFTWARE FOR TEACHING HISTORY OR CULTURE, OR FOR PROVIDING INFORMATION ABOUT HISTORIC SITES, ARTEFACTS, MUSEUMS, PEOPLE, PUBLICATIONS AND HISTORIC EVENTS; COMPUTER GAME SOFTWARE; VIRTUAL REALITY GAME SOFTWARE; ENTERTAINMENT SOFTWARE, NAMELY, COMPUTER SOFTWARE FEATURING MULTI-PLAYER ACCESS TO AN ONLINE GAME ENVIRONMENT; ELECTRONIC PUBLICATIONS, NAMELY, BOOKS, MAGAZINES, MANUALS FEATURING INFORMATION RELATING TO HISTORY, CULTURE, HISTORIC SITES, ARTEFACTS, MUSEUMS, PEOPLE, PUBLICATIONS AND HISTORIC EVENTS BEING RECORDED ON COMPUTER MEDIA AND BOOKS, MAGAZINES, MANUALS FEATURING INFORMATION RELATING TO HISTORY, CULTURE, HISTORIC SITES, ARTEFACTS, MUSEUMS, PEOPLE, PUBLICATIONS AND HISTORIC EVENTS BEING DOWNLOADABLE FROM THE INTERNET; APPARATUS FOR RECORDING, TRANSMISSION OR REPRODUCTION OF SOUND OR IMAGES; BLANK MAGNETIC DATA CARRIERS; PRERECORDED MAGNETIC DATA CARRIERS FEATURING INFORMATION RELATING TO HISTORY, CULTURE, HISTORIC SITES, ARTEFACTS, MUSEUMS, PEOPLE, PUBLICATIONS AND HISTORIC EVENTS; PRERECORDED DIGITAL VIDEO DISCS, CD-ROMS, DVDS FEATURING INFORMATION RELATING TO HISTORY, CULTURE, HISTORIC SITES, ARTEFACTS, MUSEUMS, PEOPLE, PUBLICATIONS AND HISTORIC EVENTS; AUDIO AND VIDEO RECORDINGS FEATURING INFORMATION RELATING TO HISTORY, CULTURE, HISTORIC SITES, ARTEFACTS, MUSEUMS, PEOPLE, PUBLICATIONS AND HISTORIC EVENTS; DOWNLOADABLE ELECTRONIC DATA FILES AND DATABASES, NAMELY, BUSINESS AND TAX FORMS, FOR USE WITH COMPUTER SOFTWARE; ELECTRONIC DATABASE IN THE FIELD OF INFORMATION RELATING TO HISTORY, CULTURE, HISTORIC SITES, ARTEFACTS, MUSEUMS, PEOPLE, PUBLICATIONS AND HISTORIC EVENTS, RECORDED ON COMPUTER MEDIA; COMPUTER SOFTWARE FOR APPLICATION AND DATABASE INTEGRATION (U.S. CLS. 21, 23, 26, 36 AND 38).

SN 85-000,755. REZZABLE PRODUCTIONS LTD, LONDON, EC2A 4BH, UNITED KINGDOM, FILED 3-29-2010.

## **HERITAGE KEY**

THE MARK CONSISTS OF STANDARD CHARACTERS WITHOUT CLAIM TO ANY PARTICULAR FONT, STYLE, SIZE, OR COLOR.

OWNER OF UNITED KINGDOM REG. NO. 2527484, DATED 9-29-2009, EXPIRES 9-29-2019.

#### **CLASS 16—PAPER GOODS AND PRINTED MATTER**

FOR PRINTED MATTER, NAMELY, BOOKS, MAGAZINES, MANUALS, HAND-OUTS, WORKBOOKS FEATURING INFORMATION RELATING TO HISTORY, CULTURE, HISTORIC SITES, ARTEFACTS, MUSEUMS, PEOPLE, PUBLICATIONS AND HISTORIC EVENTS; EDUCATIONAL PUBLICATIONS, NAMELY, BOOKS, MAGAZINES, MANUALS, HAND-OUTS, WORKBOOKS FEATURING INFORMATION RELATING TO HISTORY, CULTURE, HISTORIC SITES, ARTEFACTS, MUSEUMS, PEOPLE, PUBLICATIONS AND HISTORIC EVENTS; LEAFLETS, CATALOGUES, BROCHURES FEATURING INFORMATION RELATING TO HISTORY, CULTURE, HISTORIC SITES, ARTEFACTS, MUSEUMS, PEOPLE, PUBLICATIONS AND HISTORIC EVENTS; A SERIES OF WRITTEN ARTICLES FEATURING INFORMATION RELATING TO HISTORY, CULTURE, HISTORIC SITES, ARTEFACTS, MUSEUMS, PEOPLE, PUBLICATIONS AND HISTORIC EVENTS; CALENDARS; MAPS; PRINTED INSTRUCTIONAL, EDUCATIONAL AND TEACHING MATERIALS FEATURING INFORMATION RELATING TO HISTORY, CULTURE, HISTORIC SITES, ARTEFACTS, MUSEUMS, PEOPLE, PUBLICATIONS AND HISTORIC EVENTS; INSTRUCTION MANUALS FEATURING INFORMATION RELATING TO HISTORY, CULTURE, HISTORIC SITES, ARTEFACTS, MUSEUMS, PEOPLE, PUBLICATIONS AND HISTORIC EVENTS; PHOTOGRAPHS; STATIONERY; WRITING AND DRAWING INSTRUMENTS (U.S. CLS. 2, 5, 22, 23, 29, 37, 38 AND 50).

**CLASS 25—CLOTHING**

FOR CLOTHING, NAMELY, TROUSERS, SKIRTS, DRESSES, SHORTS, SWEATSHIRTS, SWEATERS, CARDIGANS, SHIRTS, BLOUSES, T-SHIRTS, JACKETS, COATS, GILETS, CLOAKS, NIGHTDRESSES, PAJAMAS, DRESSING GOWNS, UNDERGARMENTS, SHAWLS, SCARVES; FOOTWEAR; HEADGEAR, NAMELY, HATS, CAPS (U.S. CLS. 22 AND 39).

**CLASS 38—COMMUNICATION**

FOR COMMUNICATIONS AND TELECOMMUNICATIONS SERVICES, NAMELY, COMMUNICATIONS AND TELECOMMUNICATIONS BY COMPUTER TERMINALS, RADIO BROADCASTING, TELEVISION BROADCASTING; PROVIDING MULTIPLE-USER ACCESS TO A GLOBAL COMPUTER INFORMATION NETWORK; PROVIDING ON-LINE ELECTRONIC BULLETIN BOARDS FOR TRANSMISSION OF MESSAGES AMONG COMPUTER USERS IN THE FIELD OF GENERAL INTEREST; TELECOMMUNICATIONS SERVICES, NAMELY, PROVIDING MULTIPLE-USER ACCESS TO A GLOBAL COMPUTER INFORMATION NETWORK; PROVIDING ACCESS TO ONLINE GAME WEBSITES ON THE INTERNET; TEXT AND NUMERIC WIRELESS DIGITAL MESSAGING SERVICES IN THE FIELD OF ONLINE COMPUTER GAMES; PROVIDING ACCESS TO DATABASES; VIRTUAL CHATROOMS ESTABLISHED VIA TEXT MESSAGING; PROVIDING ONLINE FORUMS FOR TRANSMISSION OF MESSAGES AMONG COMPUTER USERS; PROVIDING ONLINE FORUMS FOR ENTERTAINMENT, EDUCATIONAL OR CULTURAL PURPOSES, NAMELY, FOR HISTORY, CULTURE, HISTORIC SITES, ARTEFACTS, MUSEUMS, PEOPLE, PUBLICATIONS AND HISTORIC EVENTS; ADVISORY, CONSULTANCY AND INFORMATION SERVICES RELATING TO ALL THE AFORESAID, NAMELY, COMMUNICATIONS AND TELECOMMUNICATIONS CONSULTATION, RADIO BROADCASTING CONSULTATION, TELEVISION BROADCASTING CONSULTATION (U.S. CLS. 100, 101 AND 104).

**CLASS 41—EDUCATION AND ENTERTAINMENT**

FOR EDUCATION, NAMELY, CLASSES AND SEMINARS IN THE FIELD OF HISTORY, CULTURE, HISTORIC SITES, ARTEFACTS, MUSEUMS, PEOPLE, PUBLICATIONS AND HISTORIC EVENTS; PROVIDING OF TRAINING SERVICES IN THE FIELD OF HISTORY, CULTURE, HISTORIC SITES, ARTEFACTS, MUSEUMS, PEOPLE, PUBLICATIONS AND HISTORIC EVENTS; ENTERTAINMENT, SPORTING AND CULTURAL ACTIVITIES, NAMELY, ORGANIZING LIVE EXHIBITIONS AND CONFERENCES IN THE FIELDS OF EDUCATION, CULTURE, SPORTS AND ENTERTAINMENT FOR NON-BUSINESS AND NON-COMMERCIAL PURPOSES; ENTERTAINMENT SERVICES, NAMELY, PROVIDING AN ONLINE COMPUTER GAME BY MEANS OF COMMUNICATIONS NETWORKS; ENTERTAINMENT SERVICES, NAMELY, PROVIDING AN ONLINE MULTI-PLAYER ELECTRONIC COMPUTER GAME; ENTERTAINMENT SERVICES, NAMELY, PROVIDING AN ONLINE COMPUTER GAME THAT MAY BE ACCESSED BY MEANS OF COMMUNICATIONS NETWORKS; ENTERTAINMENT SERVICES, NAMELY, PROVIDING VIRTUAL ENVIRONMENTS FOR CULTURAL, EDUCATIONAL, RECREATIONAL, LEISURE OR ENTERTAINMENT PURPOSES; ARRANGING EXHIBITIONS FOR ENTERTAINMENT, EDUCATIONAL OR CULTURAL PURPOSES, NAMELY, ORGANIZING LIVE EXHIBITIONS AND CONFERENCES IN THE FIELDS OF EDUCATION, CULTURE, SPORTS AND ENTERTAINMENT FOR NON-BUSINESS AND NON-COMMERCIAL PURPOSES; PROVIDING CLASSES, SEMINARS, WORKSHOPS, LECTURES IN THE FIELDS OF HISTORY, CULTURE, HISTORIC SITES, ARTEFACTS, MUSEUMS, PEOPLE, PUBLICATIONS AND HISTORIC EVENTS; ARRANGING OF QUIZZES, NAMELY, EDUCATIONAL EXAMINATION SERVICES; ADVISORY, CONSULTANCY AND INFORMATION SERVICES RELATING TO ALL THE AFORESAID, NAMELY, BUSINESS TRAINING CONSULTANCY SERVICES, CONSULTATION IN THE FIELD OF SPECIAL EVENT PLANNING FOR SOCIAL ENTERTAINMENT PURPOSES; ON-LINE JOURNALS FOR ENTERTAINMENT, EDUCATIONAL

OR CULTURAL PURPOSES, NAMELY, BLOGS FEATURING HISTORY, CULTURE, HISTORIC SITES, ARTEFACTS, MUSEUMS, PEOPLE, PUBLICATIONS AND HISTORIC EVENTS; INTERACTIVE EDUCATIONAL AND ENTERTAINMENT SERVICES, NAMELY, PROVIDING ON-LINE, NON-DOWNLOADABLE VIRTUAL GAMES FOR USE IN VIRTUAL ENVIRONMENTS CREATED FOR ENTERTAINMENT PURPOSES (U.S. CLS. 100, 101 AND 107).

**CLASS 42—SCIENTIFIC AND COMPUTER SERVICES**

FOR DESIGN AND DEVELOPMENT OF COMPUTER HARDWARE AND SOFTWARE; DESIGN AND DEVELOPMENT OF COMPUTER GAME SOFTWARE AND VIRTUAL REALITY SOFTWARE; COMPUTER SERVICES, NAMELY, CREATING AN ONLINE COMMUNITY FOR REGISTERED USERS TO PARTICIPATE IN DISCUSSIONS, GET FEEDBACK FROM THEIR PEERS, FORM VIRTUAL COMMUNITIES AND ENGAGE IN SOCIAL NETWORKING; REPAIR AND MAINTENANCE OF COMPUTER SOFTWARE; ADVISORY, CONSULTANCY AND INFORMATION SERVICES RELATING TO COMPUTER SOFTWARE; ADVISORY, CONSULTANCY AND INFORMATION SERVICES RELATING TO SCIENTIFIC RESEARCH IN THE FIELD OF HISTORY, CULTURE, HISTORIC SITES, ARTEFACTS, MUSEUMS, PEOPLE, PUBLICATIONS AND HISTORIC EVENTS (U.S. CLS. 100 AND 101).

MARCIE MILONE, EXAMINING ATTORNEY

SN 85-001,145. ALL SAINTS RETAIL LIMITED, LONDON, UNITED KINGDOM, FILED 3-29-2010.

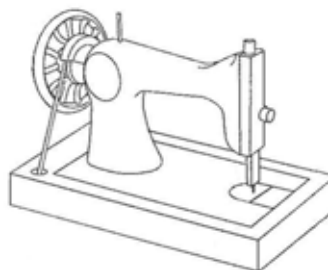

THE MARK CONSISTS OF AN IMAGE OF A SEWING MACHINE.

**CLASS 3—COSMETICS AND CLEANING PREPARATIONS**

FOR BATH SOAPS, PERFUMERY, ESSENTIAL OILS, COSMETICS, NON-MEDICATED SKIN CARE PREPARATIONS, HAIR LOTIONS, SHAMPOOS, CONDITIONERS, SHAVING PREPARATIONS AND AFTER-SHAVE PREPARATIONS, BODY DEODORANTS, DENTIFRICES, LIP BALM, EYE CREAMS AND GELS, SUNSCREEN AND TANNING PREPARATIONS, EXFOLIATORS, NAMELY, SKIN ABRASIVE PREPARATIONS AND CLEANING PREPARATIONS, LAUNDRY DETERGENT; LAUNDRY BLEACH; NON-MEDICATED BATH AND SHOWER FOAMS AND GELS, BATH AND SHOWER PREPARATIONS AND DEPILATORY COMPOSITIONS (U.S. CLS. 1, 4, 6, 50, 51 AND 52).

**CLASS 14—JEWELRY**

FOR JEWELRY, PRECIOUS STONES, HOROLOGICAL AND CHRONOMETRIC INSTRUMENTS, CLOCKS AND WATCHES, EARRINGS, KEY FOBS AND RINGS OF PRECIOUS METAL, BADGES OF PRECIOUS METAL, BUCKLES FOR WATCHSTRAPS, JEWELRY CHAINS, JEWELRY PINS, PARTS AND FITTINGS FOR ALL THE AFORESAID GOODS (U.S. CLS. 2, 27, 28 AND 50).

**CLASS 18—LEATHER GOODS**

FOR BAGS, NAMELY, TRAVEL BAGS, BEACH BAGS, LUGGAGE, RUCKSACKS, BUM BAGS, HANDBAGS, KEYCASES, TOTE BAGS, HOLD ALL BAGS, SHOULDER BAGS, WALLETS, UMBRELLAS, SATCHELS, SUITCASES, TRUNKS, VALISES, KIT BAGS, TOILETRY BAGS FOR TRAVEL, REPLACEMENT PARTS AND FITTINGS FOR ALL THE AFORESAID GOODS (U.S. CLS. 1, 2, 3, 22 AND 41).

**CLASS 25—CLOTHING**

FOR ARTICLES OF MEN'S, WOMEN'S AND CHILDREN'S CLOTHING, NAMELY, SHIRTS, PANTS, TROUSERS, T-SHIRTS, HATS, CAPS, SUITS, BLOUSES, SKIRTS, SHORTS, JEANS, UNDERGARMENTS; MEN'S, WOMEN'S AND CHILDREN'S OUTERWEAR, NAMELY, COATS, OVERCOATS, JACKETS, WIND-RESISTANT JACKETS AND SHELLS; MEN'S WOMEN'S AND CHILDREN'S ATHLETIC WEAR, NAMELY, RUNNING PANTS, ATHLETIC SHORT, SWEAT SUITS, TRACK SUITS, SWEAT PANTS, SWEAT SHIRTS; FOOTWEAR AND HEADWEAR; BELTS MADE OF LEATHER OR IMITATION LEATHER (U.S. CLS. 22 AND 39).

**CLASS 35—ADVERTISING AND BUSINESS**

FOR RETAIL AND WHOLESALE STORE SERVICES OF ARTICLES OF SOAPS, PERFUMERY, ESSENTIAL OILS, COSMETICS, SKIN PREPARATIONS, HAIR LOTIONS, SHAMPOOS, CONDITIONERS, SHAVING PREPARATIONS AND AFTER-SHAVE PREPARATIONS, DEODORANTS, DENTIFRICES, LIP BALM, EYE CREAMS AND GELS, SUNSCREEN AND TANNING PREPARATIONS, EXFOLIATORS AND CLEANING PREPARATIONS, LAUNDRY PREPARATIONS, BATH AND SHOWER FOAMS AND GELS, BATH AND SHOWER PREPARATIONS AND DEPILETORY COMPOSITIONS, JEWELRY, PRECIOUS STONES, HOROLOGICAL AND CHRONOMETRIC INSTRUMENTS, CLOCKS AND WATCHES, EARRINGS, KEY FOBS AND RINGS, BADGES, BUCKLES, CHAINS, PINS, BAGS, TRAVEL BAGS, BEACH BAGS, LUGGAGE, RUCKSACKS, BUM BAGS, HANDBAGS, KEYCASES, TOTE BAGS, HOLD ALL BAGS, SHOULDER BAGS, BELTS MADE OF LEATHER OR IMITATION LEATHER, WALLETS, UMBRELLAS, SATCHELS, SUITCASES, TRUNKS, VALISES, TRAVEL GOODS AND BAGS BEING MADE OF LEATHER OR IMITATION LEATHER, PARTS AND FITTINGS FOR ALL THE AFORESAID GOODS, ARTICLES OF CLOTHING, FOOTWEAR AND HEADGEAR (U.S. CLS. 100, 101 AND 102).

ANNE MADDEN, EXAMINING ATTORNEY

SN 85-004,256. DIANA INGREDIENTS S.A.S., SAINT-NOLFF, FRANCE, FILED 4-1-2010.

**DIANAPLANTSCIENCES**

THE MARK CONSISTS OF STANDARD CHARACTERS WITHOUT CLAIM TO ANY PARTICULAR FONT, STYLE, SIZE, OR COLOR.

OWNER OF FRANCE REG. NO. 103726314, DATED 3-31-2010, EXPIRES 3-31-2020.

**CLASS 1—CHEMICALS**

FOR PLANT, FRUIT AND VEGETABLE EXTRACTS FOR USE IN THE MANUFACTURE OF COSMETICS (U.S. CLS. 1, 5, 6, 10, 26 AND 46).

**CLASS 2—PAINTS**

FOR PLANT, FRUIT AND VEGETABLE EXTRACTS USED AS FOOD COLOR ADDITIVES (U.S. CLS. 6, 11 AND 16).

**CLASS 5—PHARMACEUTICALS**

FOR PLANT, FRUIT AND VEGETABLE EXTRACTS FOR MEDICAL, VETERINARY AND PHARMACEUTICAL PURPOSES; FOOD SUPPLEMENTS (U.S. CLS. 6, 18, 44, 46, 51 AND 52).

**CLASS 29—MEATS AND PROCESSED FOODS**

FOR INGREDIENTS AND FOOD ADDITIVES, NAMELY, NATURAL FOOD EXTRACTS DERIVED FROM PLANTS, FRUITS, VEGETABLES, BEEF, POULTRY, AND SEAFOOD NOT FOR MEDICINAL PURPOSES AND FOR HUMAN CONSUMPTION (U.S. CL. 46).

**CLASS 30—STAPLE FOODS**

FOR COCOA EXTRACTS FOR HUMAN CONSUMPTION; EXTRACTS USED AS FLAVORING FOR HUMAN CONSUMPTION (U.S. CL. 46).

**CLASS 31—NATURAL AGRICULTURAL PRODUCTS**

FOR INGREDIENTS AND FOOD ADDITIVES, NAMELY, NATURAL FOOD EXTRACTS DERIVED FROM PLANTS, FRUITS, VEGETABLES, BEEF, POULTRY, AND SEAFOOD NOT FOR MEDICINAL PURPOSES AND FOR ANIMAL CONSUMPTION (U.S. CLS. 1 AND 46).

WON TEAK OH, EXAMINING ATTORNEY

SN 85-004,698. DIGITALGLOBE, INC., LONGMONT, CO. FILED 4-1-2010.

**WORLDVIEW GLOBAL ALLIANCE**

THE MARK CONSISTS OF STANDARD CHARACTERS WITHOUT CLAIM TO ANY PARTICULAR FONT, STYLE, SIZE, OR COLOR.

NO CLAIM IS MADE TO THE EXCLUSIVE RIGHT TO USE "GLOBAL ALLIANCE", APART FROM THE MARK AS SHOWN.

**CLASS 9—ELECTRICAL AND SCIENTIFIC APPARATUS**

FOR DOWNLOADABLE AERIAL, GEOGRAPHIC AND SATELLITE IMAGES FOR USE AND MANIPULATION; SOFTWARE FOR USE IN MANIPULATING AERIAL, GEOGRAPHIC, AND SATELLITE IMAGERY; APPLICATION PROGRAMMING INTERFACE SOFTWARE FOR USE BY OTHERS TO CREATE, ACCESS, SEARCH, MANAGE, DOWNLOAD, VIEW, AND EDIT AERIAL, GEOGRAPHIC, AND SATELLITE IMAGERY AND VECTOR DATA AND TO INTEGRATE SELECTED IMAGES AND DATA INTO PORTALS, WEB-APPLICATIONS, PROGRAMS, AND WE-SERVICES ENABLED DEVICES FOR ACCESS AND USE BY OTHER THIRD PARTIES (U.S. CLS. 21, 23, 26, 36 AND 38).

**CLASS 35—ADVERTISING AND BUSINESS**

FOR BUSINESS-TO-BUSINESS ELECTRONIC RETAIL AND WHOLESALE IMAGE PROVIDER SERVICES, NAMELY, PROVIDING A SERVICE THAT ALLOWS CUSTOMERS TO PURCHASE GEOGRAPHIC AND EARTH IMAGES CAPTURED BY AIRCRAFT AND SATELLITE, WHERE CUSTOMERS INCLUDE TELEVISION STATIONS, REAL ESTATE AGENCIES, MAP PRODUCERS, EDUCATIONAL INSTITUTIONS AND THE LIKE (U.S. CLS. 100, 101 AND 102).

**CLASS 38—COMMUNICATION**

FOR ELECTRONIC DELIVERY OF IMAGES, PHOTOGRAPHS AND MAPS VIA A GLOBAL COMPUTER NETWORK (U.S. CLS. 100, 101 AND 104).

**CLASS 41—EDUCATION AND ENTERTAINMENT**

FOR DIGITAL IMAGING SERVICES OF AERIAL, GEOGRAPHIC AND SATELLITE IMAGES (U.S. CLS. 100, 101 AND 107).

**CLASS 42—SCIENTIFIC AND COMPUTER SERVICES**

FOR PROVIDING GEOGRAPHIC COORDINATE DATA AND TOPOGRAPHIC INFORMATION VIA IMAGES OF AERIAL, GEOGRAPHIC AND SATELLITE IMAGERY DATA OF THE EARTH; COMPUTER SERVICES IN THE NATURE OF ELECTRONIC IMAGING OF AERIAL, GEOGRAPHIC, AND SATELLITE IMAGES (U.S. CLS. 100 AND 101).

LEIGH LOWRY, EXAMINING ATTORNEY

**CLASS 35—ADVERTISING AND BUSINESS**

FOR BUSINESS MANAGEMENT, BUT EXCLUDING ANY SUCH SERVICES PROVIDED BY A JUGGLER OR RELATING TO JUGGLING; DISSEMINATION OF ADVERTISING MATTER, BUT EXCLUDING ANY SUCH SERVICES PROVIDED BY A JUGGLER OR RELATING TO JUGGLING; BUSINESS MARKETING CONSULTING SERVICES, BUT EXCLUDING ANY SUCH SERVICES PROVIDED BY A JUGGLER OR RELATING TO JUGGLING; MANAGEMENT OF PERFORMING ARTISTS, BUT EXCLUDING ANY SUCH SERVICES PROVIDED BY A JUGGLER OR RELATING TO JUGGLING; ENTERTAINMENT MARKETING SERVICES, NAMELY, MARKETING, PROMOTION AND ADVERTISING FOR PROFESSIONAL ARTISTS, BUT EXCLUDING ANY SUCH SERVICES PROVIDED BY A JUGGLER OR RELATING TO JUGGLING; PUBLIC RELATIONS SERVICES, BUT EXCLUDING ANY SUCH SERVICES PROVIDED BY A JUGGLER OR RELATING TO JUGGLING; PUBLICATION OF PUBLICITY TEXTS IN PRINT AND ON-LINE, BUT EXCLUDING ANY SUCH SERVICES PROVIDED BY A JUGGLER OR RELATING TO JUGGLING; ADVERTISING AND PUBLICITY SERVICES, BUT EXCLUDING ANY SUCH SERVICES PROVIDED BY A JUGGLER OR RELATING TO JUGGLING; PROMOTING THE GOODS AND SERVICES OF OTHERS VIA A GLOBAL COMPUTER NETWORK AND BY MEANS OF DISTRIBUTING ADVERTISING ON THE INTERNET, BUT EXCLUDING ANY SUCH SERVICES PROVIDED BY A JUGGLER OR RELATING TO JUGGLING; PROMOTING THE GOODS AND SERVICES OF OTHERS BY PROVIDING HYPERTEXT LINKS TO THE WEB SITES OF OTHERS, BY PROVIDING A WEB SITE AT WHICH USERS CAN LINK TO ENTERTAINMENT, COMEDY, COMEDY AND THEATER ACTS, AND COMEDY AND THEATER EVENTS, AND BY MEANS OF OPERATING AN ON-LINE SHOPPING MALL WITH LINKS TO THE RETAIL WEB SITES OF OTHERS, BUT EXCLUDING ANY SUCH SERVICES PROVIDED BY A JUGGLER OR RELATING TO JUGGLING; PROMOTING THE GOODS AND SERVICES OF OTHERS THROUGH ON-LINE ORDERING AND CATALOGING OF THOSE GOODS AND SERVICES, BUT EXCLUDING ANY SUCH SERVICES PROVIDED BY A JUGGLER OR RELATING TO JUGGLING (U.S. CLS. 100, 101 AND 102).

SN 85-004,946. DAVY, JOHN ROBERT, LONDON, UNITED KINGDOM, AND KEMPINSKA, MARIA ZOFIA, LONDON, UNITED KINGDOM, FILED 4-2-2010.

# JONGLEURS

THE MARK CONSISTS OF STANDARD CHARACTERS WITHOUT CLAIM TO ANY PARTICULAR FONT, STYLE, SIZE, OR COLOR.

OWNER OF U.S. REG. NOS. 2,774,327 AND 2,778,950.  
THE ENGLISH TRANSLATION OF "JONGLEURS" IN THE MARK IS "JUGGLERS".

**CLASS 38—COMMUNICATION**

FOR AUDIO AND VIDEO BROADCASTING SERVICES VIA THE INTERNET OR OTHER COMMUNICATIONS NETWORK, NAMELY, UPLOADING, POSTING, SHOWING, DISPLAYING, TAGGING AND ELECTRONICALLY TRANSMITTING INFORMATION, AUDIO, AND VIDEO CLIPS, BUT EXCLUDING ANY SUCH SERVICES PROVIDED BY A JUGGLER OR RELATING TO JUGGLING; INTERNET BROADCASTING SERVICES, BUT EXCLUDING ANY SUCH SERVICES PROVIDED BY A JUGGLER OR RELATING TO JUGGLING; WEB CASTING SERVICES, BUT EXCLUDING ANY SUCH SERVICES PROVIDED BY A JUGGLER OR RELATING TO JUGGLING; PROVIDING AN ON-LINE FORUM FOR USERS FOR THE SHARING AND TRANSMISSION OF INFORMATION AND ELECTRONIC MEDIA CONCERNING ENTERTAINMENT, COMEDY, COMEDY AND THEATRE ACTS, AND COMEDY AND THEATRE EVENTS, BUT EXCLUDING ANY SUCH SERVICES PROVIDED BY A JUGGLER OR RELATING TO JUGGLING; PROVIDING ON-LINE CHAT ROOMS AND ELECTRONIC BULLETIN BOARDS FOR TRANSMISSION OF MESSAGES AMONG USERS IN THE FIELD OF ENTERTAINMENT, COMEDY, COMEDY AND THEATRE ACTS, AND COMEDY AND THEATRE EVENTS, BUT EXCLUDING ANY SUCH SERVICES PROVIDED BY A JUGGLER OR RELATING TO JUGGLING (U.S. CLS. 100, 101 AND 104).

**CLASS 41—EDUCATION AND ENTERTAINMENT**

FOR PROVIDING A WEBSITE FEATURING ENTERTAINMENT AND RECREATION INFORMATION, BUT EXCLUDING ANY SUCH SERVICES PROVIDED BY A JUGGLER OR RELATING TO JUGGLING; PROVIDING INFORMATION IN THE FIELD OF ENTERTAINMENT, COMEDY, COMEDY AND THEATER ACTS, AND COMEDY AND THEATER EVENTS, BUT EXCLUDING ANY SUCH SERVICES PROVIDED BY A JUGGLER OR RELATING TO JUGGLING VIA THE INTERNET; PROVIDING AN INTERNET WEBSITE PORTAL IN THE FIELD OF ENTERTAINMENT, COMEDY, COMEDY AND THEATER ACTS, AND COMEDY AND THEATER EVENTS, BUT EXCLUDING ANY SUCH SERVICES PROVIDED BY A JUGGLER OR RELATING TO JUGGLING; ENTERTAINMENT TICKET AGENCY SERVICES, BUT EXCLUDING ANY SUCH SERVICES PROVIDED BY A JUGGLER OR RELATING TO JUGGLING; PROVIDING NEWSLETTERS IN THE FIELD OF ENTERTAINMENT, COMEDY, COMEDY AND THEATER ACTS, AND COMEDY AND THEATER EVENTS VIA E-MAIL, BUT EXCLUDING ANY SUCH SERVICES PROVIDED BY A JUGGLER OR RELATING TO JUGGLING; ON-LINE JOURNALS, NAMELY, BLOGS FEATURING INFORMATION IN THE FIELD OF ENTERTAINMENT, COMEDY, COMEDY AND THEATER ACTS, AND COMEDY AND THEATER EVENTS, BUT EXCLUDING ANY SUCH SERVICES PROVIDED BY A JUGGLER OR RELATING TO JUGGLING; INFORMATION SERVICES, NAMELY, PROVIDING A WEB SITE FEATURING AUDIO AND VIDEO IN THE FIELD OF ENTERTAINMENT, COMEDY, COMEDY AND THEATER ACTS, AND COMEDY AND THEATER EVENTS, BUT EXCLUDING ANY SUCH SERVICES PROVIDED BY A JUGGLER OR RELATING TO JUGGLING (U.S. CLS. 100, 101 AND 107).

DAVID TAYLOR, EXAMINING ATTORNEY

**CLASS 41—EDUCATION AND ENTERTAINMENT**

FOR NON-DOWNLOADABLE ELECTRONIC PUBLICATIONS IN THE NATURE OF GENERAL FEATURE MAGAZINES AND NEWSLETTERS FOR WOMEN IN THE FIELD OF LIFE STYLE, BEAUTY, CLOTHING, SHOPPING, MENTAL AND PHYSICAL HEALTH, FITNESS, EXERCISE, DIET, DECORATING, ART AND ARCHITECTURE, INTERIOR DESIGN, ENTERTAINMENT, FOOD AND FOOD RECIPES, DINING, PARTY PLANNING, CRAFT INSTRUCTIONS, FAMILY PROJECTS, FAMILY ISSUES, PARENTING, CHILD DEVELOPMENT, CHILDREN AND FAMILY RELATIONS, CHARITABLE GIVING, AND VOLUNTEERISM; ENTERTAINMENT SERVICES, NAMELY, PROVIDING ON-LINE REVIEWS OF COMMUNITY EVENTS IN THE NATURE OF SPORTING EVENTS, WINE TASTINGS, MUSIC CONCERTS, MOVIES, THEATRE, FAIRS AND FESTIVALS, DANCE PERFORMANCES, CRAFTS MARKETS, ART AND ARCHITECTURE; PROVIDING A WEB SITE WHERE USERS CAN POST RATINGS, REVIEWS AND RECOMMENDATIONS ON EVENTS AND ACTIVITIES IN THE FIELD OF ENTERTAINMENT AND EDUCATION; PROVIDING ADVICE AND INFORMATION IN THE FIELD OF EDUCATIONAL AND ENTERTAINMENT ACTIVITIES AND EVENTS; ORGANIZING COMMUNITY, SPORTING AND CULTURAL EVENTS (U.S. CLS. 100, 101 AND 107).

FIRST USE 5-1-2007; IN COMMERCE 5-1-2007.

**CLASS 43—HOTEL AND RESTAURANT SERVICES**

FOR ENTERTAINMENT SERVICES, NAMELY, PROVIDING ON-LINE REVIEWS OF RESTAURANTS AND HOTELS (U.S. CLS. 100 AND 101).

FIRST USE 5-1-2007; IN COMMERCE 5-1-2007.

SUSAN STIGLITZ, EXAMINING ATTORNEY

SN 85-006,114. MAKE IT BETTER LLC, WILMETTE, IL. FILED 4-5-2010.



NO CLAIM IS MADE TO THE EXCLUSIVE RIGHT TO USE "NORTH SHORE", APART FROM THE MARK AS SHOWN.

THE MARK CONSISTS OF FOUR FEMALE FIGURES ALIGNED HORIZONTALLY WITH THE FIGURE FURTHEST TO THE LEFT HOLDING A SMALL BARBELL AND THE FIGURE FURTHEST TO THE RIGHT WEARING EYEGLASSES. THESE FIGURES APPEAR TO THE LEFT OF THE WORDING "MAKE IT BETTER NORTH SHORE - FAMILY, COMMUNITY AND YOU".

**CLASS 35—ADVERTISING AND BUSINESS**

FOR PROMOTING VISUAL AND PERFORMING ARTS EVENTS BY MEANS OF PROVIDING AN ONLINE EVENTS CALENDAR, ORIGINAL ARTICLES, INTERVIEWS, INFORMATION ABOUT ART, ARTISTS AND ART EVENTS VIA AN INTERNET WEB SITE, ALL FOR PROMOTIONAL PURPOSES; PROVIDING CONSUMER INFORMATION SERVICES AND MAKING REFERRALS IN THE FIELD OF ENTERTAINMENT AND RETAIL SERVICES FOR PRODUCTS, SERVICES, EVENTS, ACTIVITIES, ATTRACTIONS, FACILITIES AND LOCATIONS; PROVIDING MARKETING AND PROMOTION OF SPECIAL EVENTS; PROVIDING ONLINE REVIEWS OF RETAIL STORES (U.S. CLS. 100, 101 AND 102).

FIRST USE 5-31-2007; IN COMMERCE 5-31-2007.

SN 85-006,227. UNIVERSITY CONNECTIONS, LLC, HOUSTON, TX. FILED 4-5-2010.

**University Connections**

THE MARK CONSISTS OF STANDARD CHARACTERS WITHOUT CLAIM TO ANY PARTICULAR FONT, STYLE, SIZE, OR COLOR.

NO CLAIM IS MADE TO THE EXCLUSIVE RIGHT TO USE "UNIVERSITY", APART FROM THE MARK AS SHOWN.

**CLASS 35—ADVERTISING AND BUSINESS**

FOR BUSINESS CONSULTING SERVICES IN THE FIELDS OF COMMUNICATION STRATEGY AND SKILLS, TEAM DEVELOPMENT, LEADERSHIP AND INTERPERSONAL SKILLS, CHANGE MANAGEMENT, WRITTEN COMMUNICATION AND EDITING, PRESENTATION TRAINING, MEETING MANAGEMENT, CROSS-CULTURAL COMMUNICATIONS, NEGOTIATIONS, INTERNAL AND EXTERNAL RELATIONS, BUSINESS DEVELOPMENT AND SALES, MENTORING IN THE NATURE OF ON-BOARDING, AND NEW HIRE ORIENTATION (U.S. CLS. 100, 101 AND 102).

FIRST USE 1-1-2005; IN COMMERCE 1-1-2005.

**CLASS 41—EDUCATION AND ENTERTAINMENT**

FOR EDUCATIONAL TRAINING SERVICES, NAMELY, CONDUCTING CLASSES, TRAINING, WORKSHOPS, ONE-ON-ONE COACHING AND GROUP COACHING IN THE FIELDS OF COMMUNICATION STRATEGY AND SKILLS, TEAM DEVELOPMENT, LEADERSHIP AND INTERPERSONAL SKILLS, CHANGE MANAGEMENT, WRITTEN COMMUNICATION AND EDITING, PRESENTATION TRAINING, MEETING MANAGEMENT, CROSS-CULTURAL COMMUNICATIONS, NEGOTIATIONS, INTERNAL AND EXTERNAL RELATIONS, BUSINESS DEVELOPMENT AND SALES, MENTORING IN THE NATURE OF ON-BOARDING, AND NEW HIRE ORIENTATION, AND DISTRIBUTING COURSE MATERIALS IN CONNECTION THEREWITH (U.S. CLS. 100, 101 AND 107).

FIRST USE 1-1-2005; IN COMMERCE 1-1-2005.  
NELSON SNYDER, EXAMINING ATTORNEY

SN 85-007,076. GUARDIAN MEDIA ENTERTAINMENT, LLC, BEVERLY HILLS, CA. FILED 4-6-2010.

**GUARDIAN PROJECT**

THE MARK CONSISTS OF STANDARD CHARACTERS WITHOUT CLAIM TO ANY PARTICULAR FONT, STYLE, SIZE, OR COLOR.

**CLASS 9—ELECTRICAL AND SCIENTIFIC APPARATUS**

FOR VIDEO, ELECTRONIC AND COMPUTER PRODUCTS, NAMELY, PORTABLE LISTENING DEVICES, NAMELY, MP3 PLAYERS; MP3 PLAYER SKINS; MP3 PLAYER CASES; MPV PLAYERS WITH MULTI-MEDIA CAPABILITIES; AUDIO TAPE SETS INCLUDING AN ACCOMPANYING BOOK; AUDIO AND VIDEO CARDS FOR MULTI-MEDIA APPLICATIONS; VIDEO MICRO-GAMES FOR USE WITH COMPUTERS, HANDHELD VIDEO GAME PLAYERS, VIDEO GAME CONSOLES AND HANDHELD MULTI-MEDIA COMMUNICATIONS DEVICES; BLANK USB FLASH DRIVES; DOWNLOADABLE PRE-RECORDED PHONE MESSAGES; STORAGE ACCESSORIES FOR HANDHELD DEVICES, NAMELY, CASES FOR SMALL HANDHELD COMPUTERS; ELECTRONIC DOCKING STATIONS; RADIOS; COMPUTER GAME SOFTWARE FOR USE WITH PERSONAL COMPUTERS, HOME VIDEO GAME CONSOLES USED WITH TELEVISIONS, AND FOR ARCADE-BASED VIDEO GAME CONSOLES; COMPUTER GAME SOFTWARE DOWNLOADABLE FROM A GLOBAL COMPUTER NETWORK; COMPUTER GAME SOFTWARE FOR USE ON MOBILE AND CELLULAR PHONES; COMPUTER HARDWARE; COMPUTER MICE; DVDS FEATURING ANIMATED AND NON-ANIMATED ACTION/ADVENTURE, COMIC BOOK AND SPORTS ENTERTAINMENT FARE; COMPACT DISCS FEATURING MUSIC AND ENTERTAINMENT FARE; DOWNLOADABLE AND RECORDED COMPUTER MEDIA ELECTRONIC BOOKS FEATURING ACTION/ADVENTURE, COMIC BOOK AND SPORTS ENTERTAINMENT FARE; MOUSE PADS; MAGNETIC DEVICES, NAMELY, MAGNETS; DIGITAL PHOTO FRAMES FOR DISPLAYING PICTURES, VIDEO CLIPS AND MUSIC; MOTION PICTURES, NAMELY, ANIMATED FEATURE FILMS, DOCUMENTARY FILMS, LIVE ACTION FILMS FEATURING ACTION/ADVENTURE, COMIC BOOK AND SPORTS ENTERTAINMENT FARE; DOWNLOADABLE MOTION PICTURES AND TELEVISION SHOWS FEATURING ANIMATED AND NON-ANIMATED ACTION/ADVENTURE, COMIC BOOK AND SPORTS ENTERTAINMENT FARE; TELEPHONES, NAMELY, CELL PHONES; CELL PHONE FACE PLATES; CELL PHONE HEADSETS; CELL PHONE STRAPS; WALKIE-TALKIES; EYEWEAR, NAMELY, 3D GLASSES, OPTICAL FRAMES, SUNGLASSES, PRESCRIPTION EYEWEAR, NON-PRESCRIPTION EYEWEAR, PROTECTIVE GOGGLES, NAMELY, MOTORCYCLE GOGGLES, SAFETY GOGGLES, SWIM GOGGLES, SKI AND SNOW GOGGLES AND SPORTS GOGGLES; TELESCOPES; BINOCULARS (U.S. CLS. 21, 23, 26, 36 AND 38).

SN 85-006,962. JOHNSON & JOHNSON, NEW BRUNSWICK, NJ. FILED 4-6-2010.

**REMBRANDT DEEPLY WHITE**

THE MARK CONSISTS OF STANDARD CHARACTERS WITHOUT CLAIM TO ANY PARTICULAR FONT, STYLE, SIZE, OR COLOR.

OWNER OF U.S. REG. NOS. 1,423,544, 3,587,562 AND OTHERS.

NO CLAIM IS MADE TO THE EXCLUSIVE RIGHT TO USE "WHITE" IN INTERNATIONAL CLASSES 3 AND 5, APART FROM THE MARK AS SHOWN.

**CLASS 3—COSMETICS AND CLEANING PREPARATIONS**

FOR TOOTHPASTES AND DENTIFRICES; COSMETIC TOOTH WHITENING PREPARATIONS, NAMELY, TEETH WHITENING FILMS, STRIPS, GELS, BLEACHING AGENTS, APPLICATORS, NAMELY, PENS AND WANDS, MOUTH GUARDS AND SYRINGES CONTAINING TOOTH WHITENING GEL SOLD A UNIT; NON-MEDICATED MOUTHWASH AND MOUTH RINSE (U.S. CLS. 1, 4, 6, 50, 51 AND 52).

**CLASS 5—PHARMACEUTICALS**

FOR MEDICATED MOUTHWASH AND MOUTH RINSE; MEDICATED TOOTH BLEACHING GEL (U.S. CLS. 6, 18, 44, 46, 51 AND 52).

**CLASS 44—MEDICAL, BEAUTY AND AGRICULTURAL SERVICES**

FOR WEBSITE FEATURING INFORMATION ON ORAL HEALTH (U.S. CLS. 100 AND 101).  
BARBARA GAYNOR, EXAMINING ATTORNEY

**CLASS 14—JEWELRY**

FOR CLOCKS (U.S. CLS. 2, 27, 28 AND 50).

**CLASS 20—FURNITURE AND ARTICLES NOT OTHERWISE CLASSIFIED**

FOR MAGNETIC PICTURE FRAMES (U.S. CLS. 2, 13, 22, 25, 32 AND 50).

**CLASS 41—EDUCATION AND ENTERTAINMENT**

FOR NON-DOWNLOADABLE ELECTRONIC BOOKS IN THE FIELD OF ACTION/ADVENTURE, COMIC BOOK AND SPORTS ENTERTAINMENT FARE (U.S. CLS. 100, 101 AND 107).

ELLEN BURNS, EXAMINING ATTORNEY

**CLASS 16—PAPER GOODS AND PRINTED MATTER**

FOR PRINTED MATTER, NAMELY, BOOKS IN THE FIELD OF ACTION/ADVENTURE, COMIC BOOK AND SPORTS ENTERTAINMENT FARE, COMIC BOOKS, NOVELTY BOOKS IN THE FIELD OF ACTION/ADVENTURE, COMIC BOOK AND SPORTS ENTERTAINMENT FARE, POSTER BOOKS, CHILDREN'S BOOKS, COMMEMORATIVE BOOKS FEATURING ACTION/ADVENTURE, COMIC BOOK AND SPORTS ENTERTAINMENT FARE, ACTIVITY BOOKS, COLORING BOOKS, NOTEBOOKS, APPOINTMENT BOOKS, AUTOGRAPH BOOKS, ADDRESS/TELEPHONE BOOKS, SCRAPBOOKS, DIARIES, STATISTICAL AND BIOGRAPHICAL SUMMARIES, GAME PROGRAMS, GAME TICKETS; POSTERS AND PHOTOGRAPHS, NAMELY, FRAMED POSTERS AND UNFRAMED POSTERS, PROMOTIONAL POSTERS, PHOTOGRAPHS, MATTED PHOTOGRAPHS; PRINTED SIGNAGE OF PAPER AND CARDBOARD; SIGNED PRINTED PRODUCTS, NAMELY, BIOGRAPHICAL BOOKS, COMMEMORATIVE PHOTOGRAPHS, DRAWINGS, POSTERS, TRADING CARDS AND COMIC BOOKS; FRAMED AND UNFRAMED PRINTED PRODUCTS, NAMELY, COMMEMORATIVE PHOTOGRAPHS, DRAWINGS, POSTER, TRADING CARDS AND COMIC BOOKS; PROGRAM COVERS; MOUNTED AND UNMOUNTED PERSONALIZED PHOTOGRAPHS; PHOTO ALBUMS; PAINTINGS; LITHOGRAPHIC WORKS OF ART; CALENDARS, WALL CALENDARS, MAIL ORDER CATALOGS FEATURING GENERAL RETAIL MERCHANDISE; GREETING CARDS; POSTCARDS; TRADING CARDS; HOLIDAY CARDS; INVITATION CARDS; STATIONARY SUPPLIES, NAMELY, WRITING PENS AND PENCILS, PEN AND PENCIL CASES, ENVELOPES, MEMO PADS, DRAWING RULERS, WIPE OFF MEMO BOARDS, BOOK COVERS, LETTER OPENERS, NOTECARDS, PRE-INKED STAMPERS, PRINTED AWARDS/CERTIFICATES; DESK ACCESSORIES, NAMELY, DESK BLOTTERS, DESK FILE TRAYS, DESK SETS; BOOKMARKS; PAPER WEIGHTS; COLLECTOR ALBUMS FOR COINS, PHOTOGRAPHS, STAMPS, TRADING CARDS AND COMIC BOOKS; BUMPER STICKERS; BUMPER STICKER ALBUMS; LABELS, NAMELY, PAPER LABELS AND ADHESIVE LABELS; MISCELLANEOUS COLLECTIBLES AND MEMORABILIA, NAMELY, COLLECTIBLE PAPER MONEY, STICKERS, CARICATURES, DECORATIVE PENCIL-TOP ORNAMENTS AND FIGURES MADE OF PAPER; SHELF LINERS, NAMELY, SHELF PAPER AND SELF-ADHESIVE PLASTIC SHEETS FOR LINING SHELVES; DECALS; PAPER BANNERS; PARTY GOODS, NAMELY, PAPER DECORATIONS, PAPER PARTY FAVORS, PAPER PARTY BAGS; PRINTED TISSUE PAPER, PAPER FLAGS (U.S. CLS. 2, 5, 22, 23, 29, 37, 38 AND 50).

SN 85-007,081. GUARDIAN MEDIA ENTERTAINMENT, LLC, BEVERLY HILLS, CA. FILED 4-6-2010.

**GUARDIAN PROJECT**

THE MARK CONSISTS OF STANDARD CHARACTERS WITHOUT CLAIM TO ANY PARTICULAR FONT, STYLE, SIZE, OR COLOR.

**CLASS 6—METAL GOODS**

FOR NON-LUMINOUS AND NON-MECHANICAL METAL SIGNS; COLLECTIBLE FIGURINES OF COMMON METAL (U.S. CLS. 2, 12, 13, 14, 23, 25 AND 50).

**CLASS 9—ELECTRICAL AND SCIENTIFIC APPARATUS**

FOR ELECTRIC SIGNS; NEON SIGNS; GRADUATED RULERS FOR OFFICE AND STATIONERY (U.S. CLS. 21, 23, 26, 36 AND 38).

**CLASS 14—JEWELRY**

FOR COLLECTIBLE COINS; COMMEMORATIVE MEDALS; COLLECTIBLE FIGURINES OF PRECIOUS METAL (U.S. CLS. 2, 27, 28 AND 50).

**CLASS 18—LEATHER GOODS**

FOR SOUVENIR BAGS (U.S. CLS. 1, 2, 3, 22 AND 41).

**CLASS 20—FURNITURE AND ARTICLES NOT OTHERWISE CLASSIFIED**

FOR PARTY ORNAMENTS OF PLASTIC; PLASTIC LABELS; PLASTIC MESH CUSHIONING SHEETS FOR LINING SHELVES; COLLECTIBLE COLD CAST RESIN FIGURINES (U.S. CLS. 2, 13, 22, 25, 32 AND 50).

**CLASS 21—HOUSEWARES AND GLASS**

FOR COMMEMORATIVE PLATES; COLLECTIBLE FIGURINES OF CERAMIC; COLLECTIBLE FIGURINES OF GLASS (U.S. CLS. 2, 13, 23, 29, 30, 33, 40 AND 50).

**CLASS 28—TOYS AND SPORTING GOODS**

FOR PLAYING CARDS; PAPER PARTY HATS; PLASTIC PARTY HATS (U.S. CLS. 22, 23, 38 AND 50).  
ELLEN BURNS, EXAMINING ATTORNEY



SN 85-007,095. GUARDIAN MEDIA ENTERTAINMENT, LLC, BEVERLY HILLS, CA. FILED 4-6-2010.

SN 85-007,101. GUARDIAN MEDIA ENTERTAINMENT, LLC, BEVERLY HILLS, CA. FILED 4-6-2010.

## GUARDIAN PROJECT

THE MARK CONSISTS OF STANDARD CHARACTERS WITHOUT CLAIM TO ANY PARTICULAR FONT, STYLE, SIZE, OR COLOR.

### CLASS 6—METAL GOODS

FOR HOLIDAY ORNAMENTS OF COMMON METAL; BELLS OF COMMON METAL (U.S. CLS. 2, 12, 13, 14, 23, 25 AND 50).

### CLASS 9—ELECTRICAL AND SCIENTIFIC APPARATUS

FOR SPORTS HELMETS; BICYCLE HELMETS (U.S. CLS. 21, 23, 26, 36 AND 38).

### CLASS 12—VEHICLES

FOR BICYCLES, BICYCLE BELLS (U.S. CLS. 19, 21, 23, 31, 35 AND 44).

### CLASS 20—FURNITURE AND ARTICLES NOT OTHERWISE CLASSIFIED

FOR HOLIDAY ORNAMENTS OF PLASTIC (U.S. CLS. 2, 13, 22, 25, 32 AND 50).

### CLASS 21—HOUSEWARES AND GLASS

FOR HOLIDAY ORNAMENTS OF CHINA, CRYSTAL, GLASS, PORCELAIN AND CERAMIC (U.S. CLS. 2, 13, 23, 29, 30, 33, 40 AND 50).

### CLASS 28—TOYS AND SPORTING GOODS

FOR TOYS, NAMELY, ACTION FIGURES, BOBBLE HEAD TOYS, CHILDREN'S ACTIVITY GAME KIT COMPRISING PREPRINTED PLAY SURFACE AND REUSABLE SELF-ADHERING DESIGN PIECES, BABY RATTLES, DOLLS, OUTDOOR WATER TOYS, BALLOONS, PUPPETS, PIÑATAS, BEAN BAGS, INFLATABLE TOYS, YO-YOS, TOY HOCKEY STICKS, POM-POMS, TOY PROTECTIVE EQUIPMENT, TOY PUCKS, TOY VEHICLES, DOLL CLOTHING, RUBBER BALLS, TOY AIRPLANES, BILLIARD BALLS, JIGSAW AND MANIPULATIVE PUZZLES, STUFFED ANIMALS, BOARD GAMES, NON-ELECTRONIC NON-PROGRAMMABLE HANDHELD GAMES, NON-ELECTRONIC NON-PROGRAMMABLE TABLE TOP GAMES, DART BOARDS, POOL TABLE COVERS, TABLES FOR INDOOR HOCKEY WITH AIR PROPULSION FEATURE, STICK HOCKEY GAMES, POOL TABLES, CHESS SETS, CHECKER SETS, MARBLES, GOALIE EQUIPMENT, NAMELY, PADS, MASKS, GLOVES AND MITTS, SKATE BOARDS, IN-LINE SKATES, GOLF CLUBS, INFLATABLE HOCKEY RINKS, COLLECTIBLE BOBBLE HEADS, COLLECTIBLE ACTION FIGURES, COLLECTIBLE DOLLS, COLLECTIBLE MINIATURE TOYS, COIN-OPERATED PINBALL GAMES; CHILDREN'S DRESS UP ACCESSORIES, NAMELY, TOY HELMETS FOR PLAY; MINIATURE TOY HELMETS; HOLIDAY ORNAMENTS, NAMELY, CHRISTMAS TREE ORNAMENTS; CHRISTMAS TREE ORNAMENTS, NAMELY, BELLS (U.S. CLS. 22, 23, 38 AND 50).

ELLEN BURNS, EXAMINING ATTORNEY

## GUARDIAN PROJECT

THE MARK CONSISTS OF STANDARD CHARACTERS WITHOUT CLAIM TO ANY PARTICULAR FONT, STYLE, SIZE, OR COLOR.

NO CLAIM IS MADE TO THE EXCLUSIVE RIGHT TO USE "PROJECT", APART FROM THE MARK AS SHOWN.

### CLASS 9—ELECTRICAL AND SCIENTIFIC APPARATUS

FOR DOWNLOADABLE AUDIO/VIDEO PODCASTS IN THE FIELD OF ANIMATED AND NON-ANIMATED ACTION/ADVENTURE, COMIC BOOK AND SPORTS ENTERTAINMENT FARE; DOWNLOADABLE COMPUTER GAME PROGRAMS (U.S. CLS. 21, 23, 26, 36 AND 38).

### CLASS 41—EDUCATION AND ENTERTAINMENT

FOR ENTERTAINMENT AND EDUCATION SERVICES, NAMELY, ORGANIZING AND CONDUCTING CHARITY EVENTS IN THE NATURE OF THEATRICAL AND MUSICAL ENTERTAINMENT AND SPORTING EVENTS; ORGANIZING OF HOCKEY EXHIBITIONS FOR ENTERTAINMENT PURPOSES; PRODUCTION OF COMPUTER GENERATED IMAGERY AND COMPUTER GENERATED GRAPHICS FOR MOTION PICTURES, VIDEOS, AND MOVIE TRAILERS; PRODUCTION AND DISTRIBUTION OF ONGOING PROGRAMS ON TELEVISION AND VIA THE INTERNET; PRODUCTION AND DISTRIBUTION OF MOTION PICTURE FILMS; PROVIDING ONLINE INTERACTIVE STORIES AND GAMES; ENTERTAINMENT SERVICES, NAMELY, AN ON-GOING SERIES FEATURING ANIMATED AND NON-ANIMATED ACTION/ADVENTURE, COMIC BOOK AND SPORTS ENTERTAINMENT FARE PROVIDED THROUGH TELEVISION AND WEBCASTS; PROVIDING ONLINE NON-DOWNLOADABLE COMPUTER GAMES; PROVIDING ONLINE NON-DOWNLOADABLE AUDIO/VIDEO PODCASTS IN THE FIELD OF ANIMATED AND NON-ANIMATED ACTION/ADVENTURE, COMIC BOOK AND SPORTS ENTERTAINMENT FARE; INTERNET SERVICES, NAMELY, PROVIDING AN INTERNET WEBSITE PORTAL IN THE FIELD OF ENTERTAINMENT, CULTURAL AND SPORTING EVENTS (U.S. CLS. 100, 101 AND 107).

ELLEN BURNS, EXAMINING ATTORNEY

SN 85-008,308. ACCURISTIX INC., OAKVILLE, ONTARIO, CANADA, FILED 4-7-2010.

## ACCURISTIX

THE MARK CONSISTS OF STANDARD CHARACTERS WITHOUT CLAIM TO ANY PARTICULAR FONT, STYLE, SIZE, OR COLOR.

PRIORITY CLAIMED UNDER SEC. 44(D) ON CANADA APPLICATION NO. 1474685, FILED 3-26-2010, REG. NO. 1474685, DATED 12-22-2010, EXPIRES 12-22-2025.

**CLASS 35—ADVERTISING AND BUSINESS**

FOR THIRD PARTY LOGISTICS SERVICES PROVIDED TO HEALTHCARE MANUFACTURERS OR HEALTHCARE PRODUCT OWNERS, NAMELY, SUPPLY CHAIN DISTRIBUTION MANAGEMENT, ORDER MANAGEMENT AND CUSTOMER SERVICE, ORDER FULFILLMENT, PROVIDING A GUARANTEED PRICING PROGRAM AND ASSISTING WITH THE FORMATION, NEGOTIATION, AND MANAGEMENT OF CONTRACTS WITH PUBLIC SECTOR ENTITIES, INVOICING, ACCOUNTS RECEIVABLES MANAGEMENT, RETURNS AND RECALL MANAGEMENT, NAMELY, MANAGEMENT OF RECALLED MERCHANDISE AND TRANSPORTATION MANAGEMENT SERVICES, NAMELY, PLANNING AND COORDINATING TRANSPORTATION OF GOODS FOR OTHERS, ALL OF THE FOREGOING IN THE FIELDS OF HEALTHCARE, PHARMACEUTICALS, NARCOTICS AND CONTROLLED SUBSTANCES, BIOTECHNOLOGY, BIOPHARMACEUTICALS, NUTRITIONAL HEALTH PRODUCTS, DIAGNOSTIC, LABORATORY, MEDICAL DEVICES AND EQUIPMENT, CONSUMER HEALTH PRODUCTS, NATURAL HEALTH PRODUCTS, CLINICAL TRIAL AND SAP PRODUCTS, COSMETICS, BEAUTY SUPPLIES AND RELATED HEALTHCARE PRODUCTS (U.S. CLS. 100, 101 AND 102).

**CLASS 39—TRANSPORTATION AND STORAGE**

FOR WAREHOUSING SERVICES; AND REPACKAGING ARTICLES FOR TRANSPORTATION, ALL OF THE FOREGOING IN THE FIELDS OF HEALTHCARE, PHARMACEUTICALS, NARCOTICS AND CONTROLLED SUBSTANCES, BIOTECHNOLOGY, BIOPHARMACEUTICALS, NUTRITIONAL HEALTH PRODUCTS, DIAGNOSTIC, LABORATORY, MEDICAL DEVICES AND EQUIPMENT, CONSUMER HEALTH PRODUCTS, NATURAL HEALTH PRODUCTS, CLINICAL TRIAL AND SAP PRODUCTS, COSMETICS, BEAUTY SUPPLIES AND RELATED HEALTHCARE PRODUCTS (U.S. CLS. 100 AND 105).

**CLASS 42—SCIENTIFIC AND COMPUTER SERVICES**

FOR PROVIDING QUALITY ASSURANCE SERVICES IN THE FIELDS OF HEALTHCARE, PHARMACEUTICALS, NARCOTICS AND CONTROLLED SUBSTANCES, BIOTECHNOLOGY, BIOPHARMACEUTICALS, NUTRITIONAL HEALTH PRODUCTS, DIAGNOSTIC, LABORATORY, MEDICAL DEVICES AND EQUIPMENT, CONSUMER HEALTH PRODUCTS, NATURAL HEALTH PRODUCTS, CLINICAL TRIAL AND SAP PRODUCTS, COSMETICS, BEAUTY SUPPLIES AND RELATED HEALTHCARE PRODUCTS (U.S. CLS. 100 AND 101).

MARK T. MULLEN, EXAMINING ATTORNEY

**CLASS 35—ADVERTISING AND BUSINESS**

FOR THIRD PARTY LOGISTICS SERVICES PROVIDED TO HEALTHCARE MANUFACTURERS OR HEALTHCARE PRODUCT OWNERS, NAMELY, SUPPLY CHAIN DISTRIBUTION MANAGEMENT, ORDER MANAGEMENT AND CUSTOMER SERVICE, ORDER FULFILLMENT, PROVIDING A GUARANTEED PRICING PROGRAM AND ASSISTING WITH THE FORMATION, NEGOTIATION, AND MANAGEMENT OF CONTRACTS WITH PUBLIC SECTOR ENTITIES, INVOICING, ACCOUNTS RECEIVABLES MANAGEMENT, RETURNS AND RECALL MANAGEMENT, NAMELY, MANAGEMENT OF RECALLED MERCHANDISE AND TRANSPORTATION MANAGEMENT SERVICES, NAMELY, PLANNING AND COORDINATING TRANSPORTATION OF PEOPLE FOR OTHERS, ALL OF THE FOREGOING IN THE FIELDS OF HEALTHCARE, PHARMACEUTICALS, NARCOTICS AND CONTROLLED SUBSTANCES, BIOTECHNOLOGY, BIOPHARMACEUTICALS, NUTRITIONAL HEALTH PRODUCTS, DIAGNOSTIC, LABORATORY, MEDICAL DEVICES AND EQUIPMENT, CONSUMER HEALTH PRODUCTS, NATURAL HEALTH PRODUCTS, CLINICAL TRIAL AND SAP PRODUCTS, COSMETICS, BEAUTY SUPPLIES AND RELATED HEALTHCARE PRODUCTS (U.S. CLS. 100, 101 AND 102).

**CLASS 39—TRANSPORTATION AND STORAGE**

FOR WAREHOUSING SERVICES; AND REPACKAGING ARTICLES FOR TRANSPORTATION, ALL OF THE FOREGOING IN THE FIELDS OF HEALTHCARE, PHARMACEUTICALS, NARCOTICS AND CONTROLLED SUBSTANCES, BIOTECHNOLOGY, BIOPHARMACEUTICALS, NUTRITIONAL HEALTH PRODUCTS, DIAGNOSTIC, LABORATORY, MEDICAL DEVICES AND EQUIPMENT, CONSUMER HEALTH PRODUCTS, NATURAL HEALTH PRODUCTS, CLINICAL TRIAL AND SAP PRODUCTS, COSMETICS, BEAUTY SUPPLIES AND RELATED HEALTHCARE PRODUCTS (U.S. CLS. 100 AND 105).

**CLASS 42—SCIENTIFIC AND COMPUTER SERVICES**

FOR PROVIDING QUALITY ASSURANCE SERVICES IN THE FIELDS OF HEALTHCARE, PHARMACEUTICALS, NARCOTICS AND CONTROLLED SUBSTANCES, BIOTECHNOLOGY, BIOPHARMACEUTICALS, NUTRITIONAL HEALTH PRODUCTS, DIAGNOSTIC, LABORATORY, MEDICAL DEVICES AND EQUIPMENT, CONSUMER HEALTH PRODUCTS, NATURAL HEALTH PRODUCTS, CLINICAL TRIAL AND SAP PRODUCTS, COSMETICS, BEAUTY SUPPLIES AND RELATED HEALTHCARE PRODUCTS (U.S. CLS. 100 AND 101).

MARK T. MULLEN, EXAMINING ATTORNEY

SN 85-008,341. ACCURISTIX INC., OAKVILLE ONTARIO, CANADA, FILED 4-7-2010.

SN 85-008,846. CROSBY, WILLIAM, S. DENNIS, MA. FILED 4-7-2010.



WAREHOUSE HOCKEY

PRIORITY CLAIMED UNDER SEC. 44(D) ON CANADA APPLICATION NO. 1474686, FILED 3-26-2010, REG. NO. 1474686, DATED 12-22-2010, EXPIRES 12-22-2025.

THE MARK CONSISTS OF "ACCURISTIX" & DESIGN.

THE MARK CONSISTS OF STANDARD CHARACTERS WITHOUT CLAIM TO ANY PARTICULAR FONT, STYLE, SIZE, OR COLOR.

NO CLAIM IS MADE TO THE EXCLUSIVE RIGHT TO USE "HOCKEY", APART FROM THE MARK AS SHOWN.

**CLASS 16—PAPER GOODS AND PRINTED MATTER**

FOR PAPER AND PRINTED MATERIALS, NAMELY, STICKERS AND DECALS (U.S. CLS. 2, 5, 22, 23, 29, 37, 38 AND 50).

**CLASS 25—CLOTHING**

FOR APPAREL, NAMELY, T-SHIRTS, HATS, SWEAT-SHIRTS, JACKETS (U.S. CLS. 22 AND 39).

**CLASS 41—EDUCATION AND ENTERTAINMENT**

FOR ORGANIZING AND CONDUCTING HOCKEY LEAGUES (U.S. CLS. 100, 101 AND 107).  
TEJBIR SINGH, EXAMINING ATTORNEY

---

SN 85-009,180. I.E. NETWORK, LLC, MINNEAPOLIS, MN.  
FILED 4-8-2010.

## The Alliance for a Healthier Minnesota

THE MARK CONSISTS OF STANDARD CHARACTERS WITHOUT CLAIM TO ANY PARTICULAR FONT, STYLE, SIZE, OR COLOR.

NO CLAIM IS MADE TO THE EXCLUSIVE RIGHT TO USE "THE ALLIANCE" AND "MINNESOTA", APART FROM THE MARK AS SHOWN.

**CLASS 16—PAPER GOODS AND PRINTED MATTER**

FOR BOOKS, MAGAZINES, BROCHURES AND NEWSLETTERS IN THE FIELD OF HEALTH AND WELLNESS (U.S. CLS. 2, 5, 22, 23, 29, 37, 38 AND 50).

**CLASS 35—ADVERTISING AND BUSINESS**

FOR CONDUCTING PUBLIC OPINION POLLS IN THE FIELD OF HEALTH AND WELLNESS; PROVIDING ASSISTANCE, FITNESS EVALUATION AND CONSULTATION TO CORPORATE CLIENTS TO HELP THEIR EMPLOYEES MAKE HEALTH, WELLNESS AND NUTRITIONAL CHANGES IN THEIR DAILY LIVING TO INCREASE PRODUCTIVITY AND LOWER HEALTH CARE COSTS (U.S. CLS. 100, 101 AND 102).

**CLASS 41—EDUCATION AND ENTERTAINMENT**

FOR ARRANGING AND CONDUCTING EDUCATIONAL CONFERENCES RELATED TO HEALTH AND WELLNESS (U.S. CLS. 100, 101 AND 107).

**CLASS 44—MEDICAL, BEAUTY AND AGRICULTURAL SERVICES**

FOR PROVIDING ASSISTANCE, FITNESS EVALUATION AND CONSULTATION TO CORPORATE CLIENTS TO HELP THEIR EMPLOYEES MAKE HEALTH, WELLNESS AND NUTRITIONAL CHANGES IN THEIR DAILY LIVING TO IMPROVE HEALTH; HEALTH AND WELLNESS SERVICES, NAMELY, ORGANIZING COMPETITIONS TO PROMOTE WEIGHT LOSS (U.S. CLS. 100 AND 101).

KHANH LE, EXAMINING ATTORNEY

SN 85-010,078. MTLTD TOP LEVEL DOMAIN LIMITED, IFSC, DUBLIN 1, IRELAND, FILED 4-9-2010.

## GOMOBI

THE MARK CONSISTS OF STANDARD CHARACTERS WITHOUT CLAIM TO ANY PARTICULAR FONT, STYLE, SIZE, OR COLOR.

OWNER OF ERPN CMNTY TM OFC REG. NO. 8835985, DATED 7-13-2010, EXPIRES 1-26-2020.

**CLASS 9—ELECTRICAL AND SCIENTIFIC APPARATUS**

FOR COMPUTER SOFTWARE FOR USE IN DELIVERING A MOBILE WEBSITE; SOFTWARE FOR USE IN DELIVERING A MOBILE WEBSITE DOWNLOADABLE FROM THE INTERNET (U.S. CLS. 21, 23, 26, 36 AND 38).

**CLASS 42—SCIENTIFIC AND COMPUTER SERVICES**

FOR SCIENTIFIC AND TECHNOLOGICAL SERVICES AND RESEARCH AND DESIGN RELATING THERETO, AND INDUSTRIAL ANALYSIS AND RESEARCH SERVICES, ALL THE AFORESAID RELATING TO COMPUTING, THE INTERNET AND TO DOMAIN NAMES; DESIGN AND DEVELOPMENT OF COMPUTER HARDWARE AND SOFTWARE AND COMPUTER SYSTEMS; CREATING, MAINTAINING AND HOSTING THE WEBSITES OF OTHERS; COMPUTER SERVICES, NAMELY, PROVIDING SEARCH ENGINES FOR OBTAINING DATA ON THE INTERNET; SOFTWARE DEVELOPMENT FOR THIRD PARTIES, INCLUDING IN RELATION TO ELECTRONIC MAIL, DOMAIN NAME RESERVATION, REGISTRATION, MAINTENANCE AND MANAGEMENT APPLICATIONS; ADVISORY AND CONSULTANCY SERVICES IN THE FIELDS OF INTERNET WEBSITES AND APPLICATIONS; COMPUTER SERVICES, NAMELY, PROVIDING TEMPORARY USE OF A NON-DOWNLOADABLE WEB-BASED SOFTWARE SYSTEM THAT ALLOWS FORMATTING OF WEBSITES FOR ACCURATE DISPLAY AND READING ON MOBILE DEVICES (U.S. CLS. 100 AND 101).

DAVID H. STINE, EXAMINING ATTORNEY

---

SN 85-010,263. NOMADIC SOLUTIONS, MELUN, FRANCE, FILED 4-9-2010.



THE MARK CONSISTS OF THE WORD "ECOGYZER" WITH AN ARC DESIGN IN 3 SEGMENTS ABOVE THE WORD, AND TWO SLIGHTLY CURVED PARALLEL LINES BELOW THE WORD EXTENDING FROM THE BOTTOM OF THE LETTER "Y".

**CLASS 9—ELECTRICAL AND SCIENTIFIC APPARATUS**

FOR ELECTRONIC DATA LOGGERS AND ELECTRONIC COMMUNICATIONS INSTRUMENT IN THE NATURE OF OPTICAL TRANSMITTERS FOR ANALYZING DRIVING DATA IN THE FIELD OF KILOMETERS, SPEED, FUEL CONSUMPTION ACCELERATIONS, ECOLOGICAL DRIVING OPERATION; COMPUTER SOFTWARE AND SERVERS FOR ANALYZING DRIVING DATA (U.S. CLS. 21, 23, 26, 36 AND 38).

FIRST USE 3-1-2009; IN COMMERCE 8-12-2009.

**CLASS 42—SCIENTIFIC AND COMPUTER SERVICES**

FOR DATA CONVERSION OF PROCESSED COMPUTER PROGRAM DATA; TECHNICAL RESEARCH IN THE FIELD OF ENERGY EFFICIENCY; QUALITY EVALUATION SERVICES, NAMELY, QUALITY EVALUATION IN THE FIELD OF MOTOR VEHICLES' ENERGY CONSUMPTION; ENVIRONMENTAL AUTOMOBILE FUEL EMISSION TESTING SERVICES (U.S. CLS. 100 AND 101).

FIRST USE 3-1-2009; IN COMMERCE 8-12-2009.  
DAWN HAN, EXAMINING ATTORNEY

**CLASS 42—SCIENTIFIC AND COMPUTER SERVICES**

FOR DESIGN AND DEVELOPMENT OF COMPUTER SYSTEMS IN THE FIELD OF TRANSMISSION, ELECTRONIC DELIVERY AND STREAMING OF DIGITAL MEDIA CONTENT, NAMELY, VIDEO, AUDIO, IMAGES AND TEXT, FOR OTHERS VIA THE INTERNET, TELEPHONE NETWORKS, CELLULAR NETWORKS, WIRELESS NETWORKS, CABLE TELEVISION NETWORKS AND OTHER TELECOMMUNICATIONS NETWORKS; PRODUCT RESEARCH IN THE FIELD OF THE TRANSMISSION, ELECTRONIC DELIVERY AND STREAMING OF DIGITAL MEDIA CONTENT, NAMELY, VIDEO, AUDIO, IMAGES AND TEXT, FOR OTHERS VIA THE INTERNET, TELEPHONE NETWORKS, CELLULAR NETWORKS, WIRELESS NETWORKS, CABLE TELEVISION NETWORKS AND OTHER TELECOMMUNICATIONS NETWORKS; PRODUCT DEVELOPMENT CONSULTATION REGARDING EQUIPMENT, ELECTRONIC DEVICES AND COMPUTER SYSTEMS USED IN CONNECTION WITH THE TRANSMISSION, ELECTRONIC DELIVERY AND STREAMING OF DIGITAL MEDIA CONTENT (U.S. CLS. 100 AND 101).

FLORENTINA BLANDU, EXAMINING ATTORNEY

SN 85-010,461. VIDEX, INC., SANTA CLARA, CA. FILED 4-9-2010.

SN 85-010,665. MERZ PHARMA GMBH & CO. KGAA, FRANKFURT AM MAIN, FED REP GERMANY, FILED 4-9-2010.

# SPEEDL

## MERZ AESTHETICS

THE MARK CONSISTS OF STANDARD CHARACTERS WITHOUT CLAIM TO ANY PARTICULAR FONT, STYLE, SIZE, OR COLOR.

**CLASS 35—ADVERTISING AND BUSINESS**

FOR ADVERTISING SERVICES, NAMELY, THE CREATION OF ADVERTISEMENTS FOR OTHERS DISTRIBUTED THROUGH THE INTERNET, TELEPHONE NETWORKS, CELLULAR NETWORKS, WIRELESS NETWORKS, CABLE TELEVISION NETWORKS AND OTHER TELECOMMUNICATIONS NETWORKS (U.S. CLS. 100, 101 AND 102).

**CLASS 38—COMMUNICATION**

FOR CONSULTING SERVICES IN THE FIELD OF THE TRANSMISSION, ELECTRONIC DELIVERY AND STREAMING OF DIGITAL MEDIA CONTENT, NAMELY, VIDEO, AUDIO, IMAGES AND TEXT, FOR OTHERS VIA THE INTERNET, TELEPHONE NETWORKS, CELLULAR NETWORKS, WIRELESS NETWORKS, CABLE TELEVISION NETWORKS AND OTHER TELECOMMUNICATIONS NETWORKS (U.S. CLS. 100, 101 AND 104).

THE MARK CONSISTS OF STANDARD CHARACTERS WITHOUT CLAIM TO ANY PARTICULAR FONT, STYLE, SIZE, OR COLOR.

OWNER OF ERPN CMNTY TM OFC REG. NO. 007308935, DATED 5-14-2009, EXPIRES 10-12-2018.

OWNER OF U.S. REG. NOS. 1,111,173, 2,221,421 AND OTHERS.

NO CLAIM IS MADE TO THE EXCLUSIVE RIGHT TO USE "AESTHETICS", APART FROM THE MARK AS SHOWN.

**CLASS 3—COSMETICS AND CLEANING PREPARATIONS**

FOR NON-MEDICATED SKIN CARE PREPARATIONS; COSMETICS (U.S. CLS. 1, 4, 6, 50, 51 AND 52).

**CLASS 5—PHARMACEUTICALS**

FOR A FULL LINE OF DERMATOLOGICAL AND SKIN CARE PHARMACEUTICAL PRODUCTS; PHARMACEUTICAL PREPARATIONS FOR USE IN DERMATOLOGY (U.S. CLS. 6, 18, 44, 46, 51 AND 52).

**CLASS 10—MEDICAL APPARATUS**

FOR MEDICAL INSTRUMENTS AND APPARATUS FOR USE IN DERMATOLOGICAL AND SKIN CARE (U.S. CLS. 26, 39 AND 44).

MARGARET POWER, EXAMINING ATTORNEY

SN 85-010,895. SCULPTURE HOUSE, INC., SKILLMAN, NJ.  
FILED 4-9-2010.

# Encaustips

THE MARK CONSISTS OF STANDARD CHARACTERS WITHOUT CLAIM TO ANY PARTICULAR FONT, STYLE, SIZE, OR COLOR.

## CLASS 8—HAND TOOLS

FOR HAND TOOLS FOR ENCAUSTICS, NAMELY, SCRAPERS AND SPATULAS FOR SPREADING HOT WAX; ENCAUSTIC TOOL TIP HANDLES FOR SCRAPERS AND SPATULAS FOR SPREADING HOT WAX (U.S. CLS. 23, 28 AND 44).

## CLASS 9—ELECTRICAL AND SCIENTIFIC APPARATUS

FOR ENCAUSTIC HEATED TOOL TIPS FOR ELECTRIC POWERED SOLDERING IRONS (U.S. CLS. 21, 23, 26, 36 AND 38).

AMEEN IMAM, EXAMINING ATTORNEY

SN 85-011,832. SHOWA SHELL SEKIYU K.K., TOKYO, JAPAN, FILED 4-12-2010.



PRIORITY CLAIMED UNDER SEC. 44(D) ON JAPAN APPLICATION NO. 2010-013652, FILED 2-24-2010, REG. NO. 5350638, DATED 9-3-2010, EXPIRES 9-3-2020.

NO CLAIM IS MADE TO THE EXCLUSIVE RIGHT TO USE "SOLAR", APART FROM THE MARK AS SHOWN.

THE COLOR(S) ORANGE, BLUE AND WHITE IS/ARE CLAIMED AS A FEATURE OF THE MARK.

THE MARK CONSISTS OF A GEOMETRIC CIRCLE, WITH SWIRLING AND CURVED AREAS IN THE COLORS WHITE AND BLUE APPEARING IN THE LOWER PORTION OF THE CIRCLE, AND WITH THE UPPER PORTION OF THE CIRCLE APPEARING IN THE COLOR ORANGE. THE WORDING "SOLAR FRONTIER" APPEARS TO THE RIGHT OF THE CIRCLE, WITH THE WORD "SOLAR" APPEARING IN THE COLOR ORANGE, AND THE WORD "FRONTIER" APPEARING IN THE COLOR BLUE.

## CLASS 6—METAL GOODS

FOR METAL ROOFING INCORPORATING SOLAR CELLS; BUILDING MATERIALS OF METAL INCORPORATING SOLAR CELLS, NAMELY, COMPOSITE PANELS COMPOSED PRIMARILY OF METAL; METAL REINFORCEMENT MATERIALS FOR BUILDING INCORPORATING SOLAR CELLS; METAL MATERIALS USED EXCLUSIVELY FOR BUILDING OR CONSTRUCTION INCORPORATING SOLAR CELLS, NAMELY, METAL WALLS, DOORS AND WINDOWS INCORPORATING SOLAR CELLS; PREFABRICATED METAL BUILDINGS INCORPORATING SOLAR CELLS; SOLAR PANEL MOUNTS MADE OF METAL (U.S. CLS. 2, 12, 13, 14, 23, 25 AND 50).

## CLASS 19—NON-METALLIC BUILDING MATERIALS

FOR ROOFING, NOT OF METAL, INCORPORATING SOLAR CELLS; NON-METAL BUILDING MATERIALS INCORPORATING SOLAR CELLS, NAMELY, WALLS, DOORS AND WINDOWS; PREFABRICATED BUILDINGS NOT OF METAL, INCORPORATING SOLAR CELLS (U.S. CLS. 1, 12, 33 AND 50).

REBECCA SMITH, EXAMINING ATTORNEY

SN 85-011,964. PRESCOTT BREWING COMPANY, INC., PRESCOTT, AZ. FILED 4-12-2010.

# PBC

THE MARK CONSISTS OF STANDARD CHARACTERS WITHOUT CLAIM TO ANY PARTICULAR FONT, STYLE, SIZE, OR COLOR.

## CLASS 32—LIGHT BEVERAGES

FOR BEVERAGES, NAMELY, BEER AND ALE (U.S. CLS. 45, 46 AND 48).

FIRST USE 3-15-1994; IN COMMERCE 3-15-1994.

## CLASS 43—HOTEL AND RESTAURANT SERVICES

FOR BAR AND RESTAURANT SERVICES (U.S. CLS. 100 AND 101).

FIRST USE 3-15-1994; IN COMMERCE 3-15-1994.

MARK SHINER, EXAMINING ATTORNEY

SN 85-012,018. DIAMOND FOODS, INC., STOCKTON, CA. FILED 4-12-2010.

# MOVIE NIGHT MAKER

THE MARK CONSISTS OF STANDARD CHARACTERS WITHOUT CLAIM TO ANY PARTICULAR FONT, STYLE, SIZE, OR COLOR.

NO CLAIM IS MADE TO THE EXCLUSIVE RIGHT TO USE "MOVIE", APART FROM THE MARK AS SHOWN.

## CLASS 35—ADVERTISING AND BUSINESS

FOR PROVIDING ON-LINE CONSUMER INFORMATION CONCERNING THE LOCATION OF SNACK FOOD PROVIDERS; PROVIDING ON-LINE CONSUMER INFORMATION IN THE FIELD OF MOTION PICTURE FILMS TO ASSIST IN THE SELECTION OF FILMS FOR VIEWING PARTIES (U.S. CLS. 100, 101 AND 102).

FIRST USE 2-5-2010; IN COMMERCE 2-5-2010.

**CLASS 42—SCIENTIFIC AND COMPUTER SERVICES**

FOR COMPUTER SERVICES, NAMELY, PROVIDING A WEB SITE FOR OTHERS THAT AUTOMATES PARTY AND ENTERTAINMENT EVENTS MANAGEMENT THAT CONSISTS OF MOVIE VIEWING PARTY INVITATION CREATION AND DELIVERY (U.S. CLS. 100 AND 101).

FIRST USE 2-5-2010; IN COMMERCE 2-5-2010.  
JIM RINGLE, EXAMINING ATTORNEY

SN 85-012,891. DENISON, ANNA U., KNOXVILLE, TN.  
FILED 4-13-2010.

**FRETS ALIVE**

THE MARK CONSISTS OF STANDARD CHARACTERS WITHOUT CLAIM TO ANY PARTICULAR FONT, STYLE, SIZE, OR COLOR.

**CLASS 9—ELECTRICAL AND SCIENTIFIC APPARATUS**

FOR PRE-RECORDED DIGITAL VIDEO DISCS AND DIGITAL MEDIA STORAGE DEVICES FEATURING INFORMATION ABOUT MUSIC AND MUSIC INSTRUCTION (U.S. CLS. 21, 23, 26, 36 AND 38).

**CLASS 41—EDUCATION AND ENTERTAINMENT**

FOR MUSIC LESSONS, ONLINE WEBSITE FEATURING MUSIC INFORMATION, AND MUSIC INSTRUCTION (U.S. CLS. 100, 101 AND 107).

PRISCILLA MILTON, EXAMINING ATTORNEY

SN 85-012,421. CYCLES LAMBERT INC., LEVIS, CANADA,  
FILED 4-13-2010.

**TOBA**

THE MARK CONSISTS OF STANDARD CHARACTERS WITHOUT CLAIM TO ANY PARTICULAR FONT, STYLE, SIZE, OR COLOR.

**CLASS 7—MACHINERY**

FOR PNEUMATIC TOOLS IN THE NATURE OF PUMPS (U.S. CLS. 13, 19, 21, 23, 31, 34 AND 35).

**CLASS 8—HAND TOOLS**

FOR BICYCLE TOOLS, NAMELY, HAND TOOLS FOR REPAIR AND MAINTENANCE OF BICYCLES IN THE NATURE OF TOOLS FOR WHEELS AND TIRES; COMBINATION TOOLS IN THE NATURE OF HEX KEYS, HEXALOBULAR KEYS, CHAIN TOOLS, PHILLIPS SCREWDRIVERS, FLAT SCREWDRIVERS, SPOKE WRENCHES, TIRE LEVERS, BOX END WRENCHES, ADJUSTABLE WRENCHES, LOCK RING HOOKS, PEDAL WRENCHES, SOCKETS, DUST CAP REMOVERS; HEX KEYS; CHAIN TOOLS; DRAWPLATES; SPLINE WRENCHES (U.S. CLS. 23, 28 AND 44).

**CLASS 12—VEHICLES**

FOR BICYCLE PARTS AND ACCESSORIES, NAMELY, FORKS, STEMS, HANDLEBARS, HANDLEBAR END FITTINGS IN THE NATURE OF EXTENSIONS, BICYCLE PANNIERS, GRIPS AND HANDLEBAR TAPES, WHEEL RIMS, INNER TUBES, SADDLE POSTS, SADDLES, QUICK RELEASES FOR BICYCLE WHEELS, SADDLE COLLARS, SEAT CLAMPS, FORK ADAPTORS, BICYCLE STANDS; SADDLE COLLARS, BOTTLE HOLDERS, BICYCLE PUMPS, MIRRORS, BASKETS ADAPTED FOR BICYCLES, BICYCLE STANDS, BICYCLE BAGS, SEATS, SEAT COVERS, HANDLES, PEDALS, STEMS, SEAT POSTS, SEAT CLAMPS, SADDLES, GRIPS (U.S. CLS. 19, 21, 23, 31, 35 AND 44).

**CLASS 25—CLOTHING**

FOR SPORTING APPAREL, NAMELY, VESTS, APRONS, CYCLING SHOES, BANNERS IN THE NATURE OF COMPETITORS NUMBERS OF TEXTILE, TQUES, PEAK CAPS, CAPS (U.S. CLS. 22 AND 39).  
MICHAEL KEATING, EXAMINING ATTORNEY

SN 85-013,061. GOOGLE INC., MOUNTAIN VIEW, CA.  
FILED 4-13-2010.

**ADX**

THE MARK CONSISTS OF STANDARD CHARACTERS WITHOUT CLAIM TO ANY PARTICULAR FONT, STYLE, SIZE, OR COLOR.

**CLASS 9—ELECTRICAL AND SCIENTIFIC APPARATUS**

FOR COMPUTER SOFTWARE FOR ADMINISTERING ONLINE EXCHANGES AND ONLINE AUCTIONS FOR BUYING AND SELLING ADVERTISING, FOR MATCHING BUYERS AND SELLERS OF ADVERTISING, FOR TRACKING ADVERTISING PERFORMANCE, FOR MANAGING, DISTRIBUTING AND SERVING ADVERTISING, FOR ANALYZING ADVERTISING DATA, FOR REPORTING ADVERTISING DATA, AND FOR OPTIMIZING ADVERTISING PERFORMANCE (U.S. CLS. 21, 23, 26, 36 AND 38).

**CLASS 42—SCIENTIFIC AND COMPUTER SERVICES**

FOR COMPUTER SERVICES, NAMELY, ACTING AS AN APPLICATION SERVICE PROVIDER (ASP) FEATURING SOFTWARE FOR ADMINISTERING ONLINE EXCHANGES AND ONLINE AUCTIONS FOR BUYING AND SELLING ADVERTISING, FOR MATCHING BUYERS AND SELLERS OF ADVERTISING, FOR TRACKING ADVERTISING PERFORMANCE, FOR MANAGING, DISTRIBUTING AND SERVING ADVERTISING, FOR ANALYZING ADVERTISING DATA, FOR REPORTING ADVERTISING DATA, AND FOR OPTIMIZING ADVERTISING PERFORMANCE (U.S. CLS. 100 AND 101).

ANDREW LEASER, EXAMINING ATTORNEY

SN 85-013,125. GOOGLE INC., MOUNTAIN VIEW, CA.  
FILED 4-13-2010.

# DFA

THE MARK CONSISTS OF STANDARD CHARACTERS WITHOUT CLAIM TO ANY PARTICULAR FONT, STYLE, SIZE, OR COLOR.

## CLASS 9—ELECTRICAL AND SCIENTIFIC APPARATUS

FOR COMPUTER SOFTWARE FOR ADMINISTERING ONLINE EXCHANGES AND ONLINE AUCTIONS FOR BUYING AND SELLING ADVERTISING, FOR MATCHING BUYERS AND SELLERS OF ADVERTISING, FOR TRACKING ADVERTISING PERFORMANCE, FOR MANAGING, DISTRIBUTING AND SERVING ADVERTISING, FOR ANALYZING ADVERTISING DATA, FOR REPORTING ADVERTISING DATA, AND FOR OPTIMIZING ADVERTISING PERFORMANCE (U.S. CLS. 21, 23, 26, 36 AND 38).

## CLASS 42—SCIENTIFIC AND COMPUTER SERVICES

FOR COMPUTER SERVICES, NAMELY, ACTING AS AN APPLICATION SERVICE PROVIDER (ASP) FEATURING SOFTWARE FOR ADMINISTERING ONLINE EXCHANGES AND ONLINE AUCTIONS FOR BUYING AND SELLING ADVERTISING, FOR MATCHING BUYERS AND SELLERS OF ADVERTISING, FOR TRACKING ADVERTISING PERFORMANCE, FOR MANAGING, DISTRIBUTING AND SERVING ADVERTISING, FOR ANALYZING ADVERTISING DATA, FOR REPORTING ADVERTISING DATA, AND FOR OPTIMIZING ADVERTISING PERFORMANCE (U.S. CLS. 100 AND 101).

ANDREW LEASER, EXAMINING ATTORNEY

SN 85-013,136. GOOGLE INC., MOUNTAIN VIEW, CA.  
FILED 4-13-2010.

# DFP

THE MARK CONSISTS OF STANDARD CHARACTERS WITHOUT CLAIM TO ANY PARTICULAR FONT, STYLE, SIZE, OR COLOR.

## CLASS 9—ELECTRICAL AND SCIENTIFIC APPARATUS

FOR COMPUTER SOFTWARE FOR ADMINISTERING ONLINE EXCHANGES AND ONLINE AUCTIONS FOR BUYING AND SELLING ADVERTISING, FOR MATCHING BUYERS AND SELLERS OF ADVERTISING, FOR TRACKING ADVERTISING PERFORMANCE, FOR MANAGING, DISTRIBUTING AND SERVING ADVERTISING, FOR ANALYZING ADVERTISING DATA, FOR REPORTING ADVERTISING DATA, AND FOR OPTIMIZING ADVERTISING PERFORMANCE (U.S. CLS. 21, 23, 26, 36 AND 38).

## CLASS 42—SCIENTIFIC AND COMPUTER SERVICES

FOR COMPUTER SERVICES, NAMELY, ACTING AS AN APPLICATION SERVICE PROVIDER (ASP) FEATURING SOFTWARE FOR ADMINISTERING ONLINE EXCHANGES AND ONLINE AUCTIONS FOR BUYING AND SELLING ADVERTISING, FOR MATCHING BUYERS AND SELLERS OF ADVERTISING, FOR TRACKING ADVERTISING PERFORMANCE, FOR MANAGING, DISTRIBUTING AND SERVING ADVERTISING, FOR ANALYZING ADVERTISING DATA, FOR REPORTING ADVERTISING DATA, AND FOR OPTIMIZING ADVERTISING PERFORMANCE (U.S. CLS. 100 AND 101).

ANDREW LEASER, EXAMINING ATTORNEY

SN 85-013,220. THE WORLD HEALTH EDUCATION ORGANIZATION FOUNDATION, CHULA VISTA, CA. FILED 4-13-2010.



NO CLAIM IS MADE TO THE EXCLUSIVE RIGHT TO USE "WORLD HEALTH AND EDUCATION ORGANIZATION FOUNDATION", APART FROM THE MARK AS SHOWN.

THE MARK CONSISTS OF THE WORDS "WORLD HEALTH AND EDUCATION ORGANIZATION FOUNDATION" WRITTEN AROUND A CIRCULAR SHAPE WITH THREE LINES CUT OUT OF THE MIDDLE, AND A DOT BETWEEN THE WORDING ON THE LEFT AND RIGHT SIDE OF THE DESIGN.

## CLASS 36—INSURANCE AND FINANCIAL

FOR CHARITABLE SERVICES, NAMELY, SUPPORTING EDUCATION THROUGH FINANCIAL CONTRIBUTIONS TO EDUCATIONAL INSTITUTIONS (U.S. CLS. 100, 101 AND 102).

## CLASS 44—MEDICAL, BEAUTY AND AGRICULTURAL SERVICES

FOR CHARITABLE SERVICES, NAMELY, PROVIDING ACCESS TO HEALTHCARE AT A REDUCED COST TO THE PUBLIC (U.S. CLS. 100 AND 101).

## CLASS 45—PERSONAL AND LEGAL SERVICES

FOR CHARITABLE SERVICES, NAMELY, PROVIDING LEGAL SERVICES TO HELP THE PUBLIC ENFORCE CONTRACTUAL RESTRICTIONS TO PROTECT PATIENTS FROM INCREASED HEALTH CARE COSTS (U.S. CLS. 100 AND 101).

FRANK LATTUCA, EXAMINING ATTORNEY

SN 85-013,619. HERMES INTERNATIONAL, 75008 PARIS, FRANCE, FILED 4-14-2010.



PRIORITY CLAIMED UNDER SEC. 44(D) ON FRANCE APPLICATION NO. 093686883, FILED 10-27-2009, REG. NO. 3686883, DATED 10-27-2009, EXPIRES 10-27-2019.

OWNER OF U.S. REG. NOS. 3,561,331, 3,612,593 AND OTHERS.

THE MARK CONSISTS OF THE LETTER "H" SURROUNDED BY A CIRCLE WITH THREE HORIZONTAL RECTANGLES IN THE BACKGROUND.

#### CLASS 16—PAPER GOODS AND PRINTED MATTER

FOR PAPER, CARDBOARD AND GOODS MADE OF THESE MATERIALS, NAMELY, BOXES, BAGS, SACKS, ENVELOPES, PAPER POUCHES FOR PACKAGING, WRAPPING PAPER, PRINTING TYPES; PRINTING BLOCKS; BOOKBINDING MATERIALS; STATIONERY; PHOTOGRAPH ALBUMS AND SCRAPBOOK ALBUMS; COLORING BOOKS; AGENDAS; STATIONERY PADS; STATIONERY PAPER SHEETS; WRITING PAPER; DRAWING PADS; WRITING BOOKS; CALENDARS; NOTE BOOKS; INDEXES, NAMELY, INDEX CARDS; PENCIL LEAD HOLDERS; PENCILS; PENCIL CASES; FOUNTAIN PENS; FELT-TIP PENS; DRAWINGS; DRAWING INSTRUMENTS; STATIONERY ENVELOPES; GLUES FOR STATIONERY OR HOUSEHOLD PURPOSES; TYPEWRITERS; INSTRUCTIONAL AND TEACHING MATERIALS, NAMELY, BOOKS AND PAMPHLETS IN THE FIELD OF IN THE FIELD OF WEARING APPAREL, SHOES, HANDBAGS, WATCHES, PERFUME, LEATHER ACCESSORIES, HOME FURNISHINGS, SADDLERY AND CULTURAL EVENTS; PLASTICS FOR PACKAGING, NAMELY, BAGS, SACKS AND FILMS NOT FOR COMMERCIAL OR INDUSTRIAL PURPOSES; CHECK-BOOK HOLDERS; PHOTOGRAPHS; ENGRAVINGS; PICTURES; POSTERS; LITHOGRAPHS; BOOKS IN THE FIELD OF WEARING APPAREL, SHOES, HANDBAGS, WATCHES, PERFUME, LEATHER ACCESSORIES, HOME FURNISHINGS, SADDLERY AND CULTURAL EVENTS; CATALOGUES IN THE FIELD OF WEARING APPAREL, SHOES, HANDBAGS, WATCHES, PERFUME, LEATHER ACCESSORIES, HOME FURNISHINGS, SADDLERY AND CULTURAL EVENTS; PAMPHLETS IN THE FIELD OF WEARING APPAREL, SHOES, HANDBAGS, WATCHES, PERFUME, LEATHER ACCESSORIES, HOME FURNISHINGS, SADDLERY AND CULTURAL EVENTS; MAGAZINES IN THE FIELD OF WEARING APPAREL, SHOES, HANDBAGS, WATCHES, PERFUME, LEATHER ACCESSORIES, HOME FURNISHINGS, SADDLERY AND CULTURAL EVENTS; NEWSPAPERS; POSTAL CARDS; GREETING CARDS; MONEY CLIPS; SEALS; SIGNBOARDS OF PAPER OR CARDBOARD; LETTER OPENERS; TABLE LINENS OF PAPER; BOOKENDS; BOOKMARKERS; PASSPORT HOLDERS; WRITING PADS; HAT BOXES OF CARDBOARD; PAPER BOOK COVERS; PHOTOGRAPH STANDS; LETTER TRAYS; PENCIL CUPS; PENCIL CASE; PEN BOXES; PAPERWEIGHTS; PRINTED PAPER LABELS; ARTISTS' MATERIALS, NAMELY, PAINT BOXES AND BRUSHES, PASTEL CRAYONS, PAINTERS' EASELS, PAINTING PALETTES, PAINTING SETS FOR CHILDREN, PAINT TRAYS, DRAWING PAPER, ARTS AND CRAFT PAINT KITS, ARTS AND CRAFTS CLAY KITS, CANVAS PANELS FOR ARTISTS, ARTISTS' PENS, ARTISTS' PENCILS, MOLDS FOR MODELING CLAYS, CHALK; LEATHER AGENDA COVERS (U.S. CLS. 2, 5, 22, 23, 29, 37, 38 AND 50).

#### CLASS 18—LEATHER GOODS

FOR LEATHER AND IMITATIONS OF LEATHER, AND GOODS MADE OF THESE MATERIALS, NAMELY, HANDBAGS, TRAVELLING BAGS, RUCKSACKS, SCHOOL SATCHELS AND SCHOOL BAGS, BEACH BAGS, SHOPPING BAGS, GARMENT BAGS FOR TRAVEL AND BAGS FOR SPORT; CHANGING BAGS FOR BABIES; WHEELED BAGS, LEATHER SACKS AND POUCHES; SLING BAGS FOR CARRYING CHILDREN, POCKET WALLETS, PURSES IN LEATHER, CARD CASES; ATTACHÉ CASES, BRIEFCASES, KEY CASES IN LEATHER, TRUNKS, SUITCASES, TOILETRY POUCHES SOLD EMPTY; VANITY CASES SOLD EMPTY, SADDLERY; BOXES IN LEATHER OR IN LEATHER BOARD, PARASOLS, UMBRELLAS; TRAVELLING BAGS OF TEXTILE; CHANGING BAGS FOR BABIES MADE OF TEXTILE, BAGS SPECIALLY ADAPTED FOR TRAVELING, BAGS MADE OF TEXTILE FOR TRAVEL (U.S. CLS. 1, 2, 3, 22 AND 41).

#### CLASS 20—FURNITURE AND ARTICLES NOT OTHERWISE CLASSIFIED

FOR FURNITURE, PICTURE FRAMES, CHESTS FOR TOYS, NON-METAL BINS, CUSHIONS, MATTRESSES, BOXES AND CASES OF WOOD AND PLASTIC, MIRRORS, HAND-HELD MIRRORS; TABLE TOPS, UMBRELLA STANDS, BOOK RESTS; MAGAZINE RACKS, HAT STANDS, SEATS, SCREENS, TABLES, OFFICE FURNITURE, DESKS, WORKS OF ART OF WOOD, WAX, PLASTER AND PLASTIC; DECORATIVE MOBILES; WIND CHIMES; TEXTILE INDOOR BLINDS; SLEEPING BAGS (U.S. CLS. 2, 13, 22, 25, 32 AND 50).

#### CLASS 24—FABRICS

FOR SILK CLOTHS, WOVEN, NON-WOVEN OR KNITTED FABRICS FOR THE MANUFACTURE OF CLOTHING; BED BLANKETS AND TABLE LINENS, CURTAINS MADE OF TEXTILE OR MADE OF PLASTIC; FABRIC TABLE RUNNERS, COVERS FOR CUSHIONS, BEDSPREADS, BED LINEN, BED SHEETS, BATH SHEETS, FACE TOWELS, WASHING MITTS, GUEST TOWELS, TABLE LINEN NOT OF PAPER, TEXTILE NAPKINS, PLACE MATS NOT MADE OF PAPER, HANDKERCHIEFS MADE OF TEXTILE; LABELS OF CLOTH, TRACED CLOTHS FOR EMBROIDERY, BOXES MADE OF TEXTILE; UPHOLSTERY FABRICS, TRAVELLING RUGS, TAPESTRY MADE OF TEXTILE; BAGS SPECIALLY ADAPTED FOR TRAVELLING RUGS (U.S. CLS. 42 AND 50).

#### CLASS 25—CLOTHING

FOR T-SHIRTS, SWEATSHIRTS, SHORTS, TANK TOPS, JEANS, SWEATERS, SHORTS, PANTS, JACKETS, JUMPSUITS, JERSEYS; SHIRTS; DRESSES; SWIMWEAR; RAINCOATS, PARKAS, PONCHOS, SLEEPWEAR, UNDERWEAR; ROBES; MITTENS; APRONS; HEADBANDS; HOSIERY; BATHROBES; DRESSING GOWNS, BOOTS, SHOES, SLIPPERS, HATS, CAPS, GLOVES, TIES, BELTS, SCARVES, POCKET SQUARES, SASHES, STOCKINGS, SOCKS, TIGHTS, SUSPENDERS AND PAREOS (U.S. CLS. 22 AND 39).

#### CLASS 34—SMOKERS' ARTICLES

FOR MATCHES, MATCH BOXES, CIGARETTE CASES AND BOXES, CIGAR CASES AND BOXES, LIGHTERS FOR SMOKERS, ASHTRAYS FOR SMOKERS, CIGAR CUTTERS, TOBACCO JARS AND SNUFF BOXES ALL NOT IN PRECIOUS METAL (U.S. CLS. 2, 8, 9 AND 17).  
HEATHER BIDDULPH, EXAMINING ATTORNEY



SN 85-013,984. THE COLMAN GROUP, INC., ELKHORN, WI.  
FILED 4-14-2010.

SN 85-014,752. BETTER METAL, LLC, LA VERGNE, TN.  
FILED 4-15-2010.

# CHEF-TEX

THE MARK CONSISTS OF STANDARD CHARACTERS WITHOUT CLAIM TO ANY PARTICULAR FONT, STYLE, SIZE, OR COLOR.

## CLASS 24—FABRICS

FOR FABRIC FOR CHEF'S CLOTHING (U.S. CLS. 42 AND 50).

## CLASS 25—CLOTHING

FOR JACKETS, PANTS, AND APRONS (U.S. CLS. 22 AND 39).  
ZACHARY BELLO, EXAMINING ATTORNEY



SN 85-014,390. PROXIMA, INC., DBA NICKA K. COSMETICS, JAMAICA, NY. FILED 4-15-2010.

THE MARK CONSISTS OF RECTANGLE BOX THAT CONTAINS THE PHRASE "BETTER" IN ALL CAPS; ABOVE A SAME SIZE RECTANGLE BOX THAT CONTAIN THE PHRASE "METAL" IN ALL CAPS AND ON THE RIGHT OUTER SIDE HAS THE PHRASE ".COM" IN SMALL CAPS. SEC. 2(F) AS TO "BETTER METAL.COM".

# ABSOLUTE!

THE MARK CONSISTS OF STANDARD CHARACTERS WITHOUT CLAIM TO ANY PARTICULAR FONT, STYLE, SIZE, OR COLOR.  
OWNER OF U.S. REG. NO. 2,932,248.

## CLASS 3—COSMETICS AND CLEANING PREPARATIONS

FOR WIPES IMPREGNATED WITH A SKIN CLEANSER; TISSUES IMPREGNATED WITH A SKIN CLEANSER FOR REMOVING MAKE-UP; FACIAL MASKS; EYE COMPRESSES FOR COSMETIC PURPOSES; TISSUES IMPREGNATED WITH A SKIN CLEANSER FOR REMOVING OIL FROM THE SKIN; FEMININE HYGIENE CLEANSING TOWELETTES (U.S. CLS. 1, 4, 6, 50, 51 AND 52).

FIRST USE 5-16-2008; IN COMMERCE 5-16-2008.

## CLASS 5—PHARMACEUTICALS

FOR SANITIZING WIPES; ADHESIVE BANDAGES APPLIED TO THE HEEL FOR USE WHILE WEARING SHOES FOR THE ELIMINATION OR REDUCTION OF CALLUS FORMATION (U.S. CLS. 6, 18, 44, 46, 51 AND 52).

FIRST USE 5-16-2008; IN COMMERCE 5-16-2008.  
JIM RINGLE, EXAMINING ATTORNEY

## CLASS 6—METAL GOODS

FOR METAL CABLE LADDER PARTS, NAMELY, PRE-PUNCHED ANGLE RAIL AND CHANNEL RUNG LADDER SECTIONS FOR THE PURPOSE OF SUPPORTING COAXIAL CABLES; METAL BRACKETS FOR USE IN SUPPORTING COAXIAL CABLES AND FOR STABILIZING ANTENNA MOUNTS; METAL CLAMPS FOR ADAPTING COAX HANGERS TO ANGLE MEMBERS, FOR USE IN STANDING CABLE HANGERS AWAY FROM ROUND STRUCTURES AND FOR USE IN ATTACHING PIPES; METAL CONNECTORS IN THE NATURE OF GROUND LUGS USED TO SECURE GROUND WIRE TO GROUND BUSS BARS OR CONNECT SIMILAR GAUGE WIRE END TO END; METAL HARDWARE AND METAL HANGERS, NAMELY, SNAP-IN HANGERS, BUTTERFLY HANGERS, CLIP HANGERS, BLOCK HANGERS, THREADED ROD, WASHERS, BOLTS, HEX NUTS, ANGLE ADAPTERS, CLAMPS, HOISTING GRIPS AND ICE BRIDGE KITS COMPRISING METAL ICE BRIDGES, BURIAL POSTS AND TRAPEZES, ALL FOR THE PURPOSE OF SUPPORTING COAXIAL CABLE; METAL EQUIPMENT RACKS FOR SUPPORTING POWER AND TELECOMMUNICATIONS BOXES AT THE BASE OF STRUCTURES; EXOTHERMIC WELDING APPARATUS COMPRISED PRIMARILY OF WELD METAL IN THE NATURE OF WELD METAL SHOTS AND WELD METAL DISCS AND ALSO COMPRISED OF FLINT IGNITORS, ELECTRONIC IGNITORS, METAL MOLD FASTENERS, NAMELY, MECHANICAL HANDLE CLAMPS TO PHYSICALLY SECURE GRAPHITE MOLDS DURING THE EXOTHERMIC WELDING PROCESS, METAL MOUNTINGS AND METAL CLAMPS, NON-METAL WELDING MOLDS, ALL SOLD AS A UNIT FOR USE IN WELDING APPLICATIONS WHICH EMPLOY EXOTHERMIC ENERGY (U.S. CLS. 2, 12, 13, 14, 23, 25 AND 50).

FIRST USE 9-0-2002; IN COMMERCE 9-0-2002.

**CLASS 9—ELECTRICAL AND SCIENTIFIC APPARATUS**

FOR ANTENNA MOUNTS; GROUNDING KITS FOR PROTECTING COAXIAL CABLES COMPRISING GROUND WIRE IN THE NATURE OF ELECTRICAL WIRES, WEATHERPROOFING TAPE AND METAL HARDWARE; SAFETY HELMETS; FALL PROTECTION EQUIPMENT FOR FALL RESTRAINT AND FALL ARREST IN THE NATURE OF HARNESSSES, LANYARDS, RETRACTING LIFELINES, SAFETY ROPE AND SAFETY ROPE AND CABLE GRABS; METAL CONNECTORS IN THE NATURE OF SPLICES FOR ELECTRICAL TRANSMISSION LINES TO SECURE GROUND WIRE TO GROUND BUSS BARS OR CONNECT SIMILAR GAUGE WIRE END TO END; SURGE PROTECTORS; METAL CABLE TRAYS USED TO FORM A RIGID STRUCTURAL SYSTEM SPECIALLY ADAPTED FOR SECURELY FASTENING AND SUPPORTING ELECTRICAL CABLES AND RACEWAYS (U.S. CLS. 21, 23, 26, 36 AND 38).

FIRST USE 9-0-2002; IN COMMERCE 9-0-2002.

**CLASS 35—ADVERTISING AND BUSINESS**

FOR WHOLESALE DISTRIBUTORSHIPS FEATURING SITE INFRASTRUCTURE PRODUCTS FOR THE COMMUNICATIONS INDUSTRY IN THE NATURE OF METAL HARDWARE, COMMUNICATION TOWER AND ANTENNA MOUNTING PRODUCTS, CABLE LADDER, ICE BRIDGE, GROUNDING PRODUCTS, WEATHER PROOFING PRODUCTS, COAXIAL CABLE ACCESSORIES AND EXOTHERMIC WELDING APPARATUS (U.S. CLS. 100, 101 AND 102).

FIRST USE 9-0-2002; IN COMMERCE 9-0-2002.

KATHERINE CONNOLLY, EXAMINING ATTORNEY

**CLASS 6—METAL GOODS**

FOR METAL CABLE LADDER PARTS, NAMELY, PRE-PUNCHED ANGLE RAIL AND CHANNEL RUNG LADDER SECTIONS FOR THE PURPOSE OF SUPPORTING COAXIAL CABLES; METAL BRACKETS FOR USE IN SUPPORTING COAXIAL CABLES AND FOR STABILIZING ANTENNA MOUNTS; METAL CLAMPS FOR ADAPTING COAX HANGERS TO ANGLE MEMBERS, FOR USE IN STANDING CABLE HANGERS AWAY FROM ROUND STRUCTURES AND FOR USE IN ATTACHING PIPES; METAL CONNECTORS IN THE NATURE OF GROUND LUGS USED TO SECURE GROUND WIRE TO GROUND BUSS BARS OR CONNECT SIMILAR GAUGE WIRE END TO END; METAL HARDWARE AND METAL HANGERS, NAMELY, SNAP-IN HANGERS, BUTTERFLY HANGERS, CLIP HANGERS, BLOCK HANGERS, THREADED ROD, WASHERS, BOLTS, HEX NUTS, ANGLE ADAPTERS, CLAMPS, HOISTING GRIPS AND ICE BRIDGE KITS COMPRISING METAL ICE BRIDGES, BURIAL POSTS AND TRAPEZES, ALL FOR THE PURPOSE OF SUPPORTING COAXIAL CABLE; METAL EQUIPMENT RACKS FOR SUPPORTING POWER AND TELECOMMUNICATIONS BOXES AT THE BASE OF STRUCTURES; EXOTHERMIC WELDING APPARATUS COMPRISED PRIMARILY OF WELD METAL IN THE NATURE OF WELD METAL SHOTS AND WELD METAL DISCS AND ALSO COMPRISED OF FLINT IGNITORS, ELECTRONIC IGNITORS, METAL MOLD FASTENERS, NAMELY, MECHANICAL HANDLE CLAMPS TO PHYSICALLY SECURE GRAPHITE MOLDS DURING THE EXOTHERMIC WELDING PROCESS, METAL MOUNTINGS AND METAL CLAMPS, NON-METAL WELDING MOLDS, ALL SOLD AS A UNIT FOR USE IN WELDING APPLICATIONS WHICH EMPLOY EXOTHERMIC ENERGY (U.S. CLS. 2, 12, 13, 14, 23, 25 AND 50).

FIRST USE 2-14-2007; IN COMMERCE 2-14-2007.

**CLASS 9—ELECTRICAL AND SCIENTIFIC APPARATUS**

FOR ANTENNA MOUNTS; GROUNDING KITS FOR PROTECTING COAXIAL CABLES COMPRISING GROUND WIRE IN THE NATURE OF ELECTRICAL WIRES, WEATHERPROOFING TAPE AND METAL HARDWARE; SAFETY HELMETS; FALL PROTECTION EQUIPMENT FOR FALL RESTRAINT AND FALL ARREST IN THE NATURE OF HARNESSSES, LANYARDS, RETRACTING LIFELINES, SAFETY ROPE AND SAFETY ROPE AND CABLE GRABS; METAL CONNECTORS IN THE NATURE OF SPLICES FOR ELECTRICAL TRANSMISSION LINES TO SECURE GROUND WIRE TO GROUND BUSS BARS OR CONNECT SIMILAR GAUGE WIRE END TO END; SURGE PROTECTORS; METAL CABLE TRAYS USED TO FORM A RIGID STRUCTURAL SYSTEM SPECIALLY ADAPTED FOR SECURELY FASTENING AND SUPPORTING ELECTRICAL CABLES AND RACEWAYS (U.S. CLS. 21, 23, 26, 36 AND 38).

FIRST USE 2-14-2007; IN COMMERCE 2-14-2007.

**CLASS 35—ADVERTISING AND BUSINESS**

FOR WHOLESALE DISTRIBUTORSHIPS FEATURING SITE INFRASTRUCTURE PRODUCTS FOR THE COMMUNICATIONS INDUSTRY IN THE NATURE OF METAL HARDWARE, COMMUNICATION TOWER AND ANTENNA MOUNTING PRODUCTS, CABLE LADDER, ICE BRIDGE, GROUNDING PRODUCTS, WEATHER PROOFING PRODUCTS, COAXIAL CABLE ACCESSORIES AND EXOTHERMIC WELDING APPARATUS (U.S. CLS. 100, 101 AND 102).

FIRST USE 0-0-2005; IN COMMERCE 0-0-2005.

KATHERINE CONNOLLY, EXAMINING ATTORNEY

SN 85-014,757, BETTER METAL, LLC, LA VERGNE, TN.  
FILED 4-15-2010.

DEMAND BETTER.

THE MARK CONSISTS OF STANDARD CHARACTERS WITHOUT CLAIM TO ANY PARTICULAR FONT, STYLE, SIZE, OR COLOR.

SN 85-014,815. VERTEX, INC., BERWYN, PA. FILED 4-15-2010.

**VERTEX ENTERPRISE**

THE MARK CONSISTS OF STANDARD CHARACTERS WITHOUT CLAIM TO ANY PARTICULAR FONT, STYLE, SIZE, OR COLOR.

OWNER OF U.S. REG. NOS. 2,033,772, 2,907,050 AND 3,089,039.

NO CLAIM IS MADE TO THE EXCLUSIVE RIGHT TO USE "ENTERPRISE", APART FROM THE MARK AS SHOWN.

**CLASS 9—ELECTRICAL AND SCIENTIFIC APPARATUS**

FOR COMPUTER SOFTWARE FOR BUSINESS TAX MANAGEMENT, TAX RESEARCH AND TAX FILINGS, ALL DIRECTED TO ASSISTING OTHERS IN TAX COMPLIANCE AND CORPORATE TAX PERFORMANCE (U.S. CLS. 21, 23, 26, 36 AND 38).

**CLASS 42—SCIENTIFIC AND COMPUTER SERVICES**

FOR COMPUTER SERVICES, NAMELY, PROVIDING A TECHNOLOGY PLATFORM FOR INTEGRATING TAX APPLICATION SOFTWARE WITH OTHER BUSINESS AND FINANCIAL SYSTEMS FOR ASSISTING OTHERS IN TAX COMPLIANCE AND CORPORATE TAX PERFORMANCE; BUSINESS TECHNOLOGY SOFTWARE PLATFORM CONSULTATION SERVICES FOR SOFTWARE USED IN BUSINESS FINANCIAL MATTERS, NAMELY, BUSINESS TAX MANAGEMENT AND BUSINESS TAX FILINGS (U.S. CLS. 100 AND 101).  
DAVID MURRAY, EXAMINING ATTORNEY

SN 85-014,847. VERTEX, INC., BERWYN, PA. FILED 4-15-2010.

**VERTEX ENTERPRISE TAX SOLUTIONS**

THE MARK CONSISTS OF STANDARD CHARACTERS WITHOUT CLAIM TO ANY PARTICULAR FONT, STYLE, SIZE, OR COLOR.

OWNER OF U.S. REG. NOS. 2,033,772, 2,907,050 AND 3,089,039.

NO CLAIM IS MADE TO THE EXCLUSIVE RIGHT TO USE "ENTERPRISE TAX SOLUTIONS", APART FROM THE MARK AS SHOWN.

**CLASS 9—ELECTRICAL AND SCIENTIFIC APPARATUS**

FOR COMPUTER SOFTWARE FOR BUSINESS TAX MANAGEMENT, TAX RESEARCH AND TAX FILINGS, ALL DIRECTED TO ASSISTING OTHERS IN TAX COMPLIANCE AND CORPORATE TAX PERFORMANCE (U.S. CLS. 21, 23, 26, 36 AND 38).

**CLASS 42—SCIENTIFIC AND COMPUTER SERVICES**

FOR COMPUTER SERVICES, NAMELY, PROVIDING A TECHNOLOGY PLATFORM FOR INTEGRATING TAX APPLICATION SOFTWARE WITH OTHER BUSINESS AND FINANCIAL SYSTEMS FOR ASSISTING OTHERS IN TAX COMPLIANCE AND CORPORATE TAX PERFORMANCE; BUSINESS TECHNOLOGY SOFTWARE PLATFORM CONSULTATION SERVICES FOR SOFTWARE USED IN BUSINESS FINANCIAL MATTERS, NAMELY, BUSINESS TAX MANAGEMENT AND BUSINESS TAX FILINGS (U.S. CLS. 100 AND 101).  
DAVID MURRAY, EXAMINING ATTORNEY

SN 85-014,869. VERTEX, INC., BERWYN, PA. FILED 4-15-2010.

**VERTEX ENTERPRISE INDIRECT TAX SOLUTIONS**

THE MARK CONSISTS OF STANDARD CHARACTERS WITHOUT CLAIM TO ANY PARTICULAR FONT, STYLE, SIZE, OR COLOR.

OWNER OF U.S. REG. NOS. 2,033,772, 2,907,050 AND 3,089,039.

NO CLAIM IS MADE TO THE EXCLUSIVE RIGHT TO USE "ENTERPRISE INDIRECT TAX SOLUTIONS", APART FROM THE MARK AS SHOWN.

**CLASS 9—ELECTRICAL AND SCIENTIFIC APPARATUS**

FOR COMPUTER SOFTWARE FOR BUSINESS TAX MANAGEMENT, TAX RESEARCH AND TAX FILINGS, ALL DIRECTED TO ASSISTING OTHERS IN TAX COMPLIANCE AND CORPORATE TAX PERFORMANCE (U.S. CLS. 21, 23, 26, 36 AND 38).

**CLASS 42—SCIENTIFIC AND COMPUTER SERVICES**

FOR COMPUTER SERVICES, NAMELY, PROVIDING A TECHNOLOGY PLATFORM FOR INTEGRATING TAX APPLICATION SOFTWARE WITH OTHER BUSINESS AND FINANCIAL SYSTEMS FOR ASSISTING OTHERS IN TAX COMPLIANCE AND CORPORATE TAX PERFORMANCE; BUSINESS TECHNOLOGY SOFTWARE PLATFORM CONSULTATION SERVICES FOR SOFTWARE USED IN BUSINESS FINANCIAL MATTERS, NAMELY, BUSINESS TAX MANAGEMENT AND BUSINESS TAX FILINGS (U.S. CLS. 100 AND 101).  
DAVID MURRAY, EXAMINING ATTORNEY

SN 85-014,918. VERTEX, INC., BERWYN, PA. FILED 4-15-2010.

**VERTEX ENTERPRISE DIRECT TAX SOLUTIONS**

THE MARK CONSISTS OF STANDARD CHARACTERS WITHOUT CLAIM TO ANY PARTICULAR FONT, STYLE, SIZE, OR COLOR.

OWNER OF U.S. REG. NOS. 2,033,772, 2,907,050 AND 3,089,039.

NO CLAIM IS MADE TO THE EXCLUSIVE RIGHT TO USE "ENTERPRISE DIRECT TAX SOLUTIONS", APART FROM THE MARK AS SHOWN.

SN 85-015,469. ADVANCED BIOHEALING INC., LA JOLLA, CA. FILED 4-16-2010.

#### **CLASS 9—ELECTRICAL AND SCIENTIFIC APPARATUS**

FOR COMPUTER SOFTWARE FOR BUSINESS TAX MANAGEMENT, TAX RESEARCH AND TAX FILINGS, ALL DIRECTED TO ASSISTING OTHERS IN TAX COMPLIANCE AND CORPORATE TAX PERFORMANCE (U.S. CLS. 21, 23, 26, 36 AND 38).

#### **CLASS 42—SCIENTIFIC AND COMPUTER SERVICES**

FOR COMPUTER SERVICES, NAMELY, PROVIDING A TECHNOLOGY PLATFORM FOR INTEGRATING TAX APPLICATION SOFTWARE WITH OTHER BUSINESS AND FINANCIAL SYSTEMS FOR ASSISTING OTHERS IN TAX COMPLIANCE AND CORPORATE TAX PERFORMANCE; BUSINESS TECHNOLOGY SOFTWARE PLATFORM CONSULTATION SERVICES FOR SOFTWARE USED IN BUSINESS FINANCIAL MATTERS, NAMELY, BUSINESS TAX MANAGEMENT AND BUSINESS TAX FILINGS (U.S. CLS. 100 AND 101).  
DAVID MURRAY, EXAMINING ATTORNEY

SN 85-014,964. SPY MUSIC GROUP, INC., MIAMI, FL. FILED 4-15-2010.

# ZOMBITZ

THE MARK CONSISTS OF STANDARD CHARACTERS WITHOUT CLAIM TO ANY PARTICULAR FONT, STYLE, SIZE, OR COLOR.

THE WORD(S) "ZOMBITZ" HAS NO MEANING IN A FOREIGN LANGUAGE.

#### **CLASS 9—ELECTRICAL AND SCIENTIFIC APPARATUS**

FOR MOTION PICTURE FILMS ABOUT SUSPENSE AND HORROR, DOWNLOADABLE RING TONES, MUSIC, GRAPHICS, AND ELECTRONIC GAMES VIA THE INTERNET AND WIRELESS DEVICES; AUDIO, VIDEO AND AUDIOVISUAL RECORDING MEDIA, NAMELY, PRE-RECORDED DIGITAL MEDIA FEATURING SUSPENSE AND HORROR (U.S. CLS. 21, 23, 26, 36 AND 38).

#### **CLASS 25—CLOTHING**

FOR CLOTHING AND ACCESSORIES, NAMELY, SHIRTS, HATS, CAPS, HALLOWEEN COSTUMES (U.S. CLS. 22 AND 39).

#### **CLASS 28—TOYS AND SPORTING GOODS**

FOR TOYS, NAMELY, DOLLS, ACTION FIGURES, PUZZLES, COSTUME MASKS, BOARD GAMES (U.S. CLS. 22, 23, 38 AND 50).  
KATHRYN COWARD, EXAMINING ATTORNEY

# HEAL2GETHER

THE MARK CONSISTS OF STANDARD CHARACTERS WITHOUT CLAIM TO ANY PARTICULAR FONT, STYLE, SIZE, OR COLOR.

OWNER OF U.S. REG. NO. 3,705,102.

#### **CLASS 44—MEDICAL, BEAUTY AND AGRICULTURAL SERVICES**

FOR PROVIDING INFORMATION ON FOOT ULCER TREATMENTS (U.S. CLS. 100 AND 101).  
FIRST USE 4-14-2009; IN COMMERCE 4-14-2009.

#### **CLASS 45—PERSONAL AND LEGAL SERVICES**

FOR PROVIDING PERSONAL SUPPORT SERVICES FOR PATIENTS WITH FOOT ULCERS, NAMELY, PROVIDING REMINDER SERVICES ABOUT UPCOMING DOCTOR'S APPOINTMENTS AND DISTRIBUTION OF BLANK JOURNALS FOR PATIENTS TO RECORD TREATMENTS IN CONNECTION THEREWITH (U.S. CLS. 100 AND 101).

FIRST USE 4-14-2009; IN COMMERCE 4-14-2009.  
EDWARD NELSON, EXAMINING ATTORNEY

SN 85-015,471. ADVANCED BIOHEALING INC., LA JOLLA, CA. FILED 4-16-2010.



THE MARK CONSISTS OF THE OUTLINE OF A STYLIZED LEFT FOOT OVER THREE OVERLAPPING SQUARES WITH ROUNDED CORNERS.

#### **CLASS 44—MEDICAL, BEAUTY AND AGRICULTURAL SERVICES**

FOR PROVIDING INFORMATION ON FOOT ULCER TREATMENTS (U.S. CLS. 100 AND 101).  
FIRST USE 4-14-2009; IN COMMERCE 4-14-2009.

**CLASS 45—PERSONAL AND LEGAL SERVICES**

FOR PROVIDING PERSONAL SUPPORT SERVICES FOR PATIENTS WITH FOOT ULCERS, NAMELY, PROVIDING REMINDER SERVICES ABOUT UPCOMING DOCTOR'S APPOINTMENTS AND DISTRIBUTION OF BLANK JOURNALS FOR PATIENTS TO RECORD TREATMENTS IN CONNECTION THEREWITH (U.S. CLS. 100 AND 101).

FIRST USE 4-14-2009; IN COMMERCE 4-14-2009.  
EDWARD NELSON, EXAMINING ATTORNEY

SN 85-015,817. LIFE'S MEMORIES PTY LTD, ADELAIDE, SA, AUSTRALIA, FILED 4-16-2010.

**LIFE'S MEMORIES**

THE MARK CONSISTS OF STANDARD CHARACTERS WITHOUT CLAIM TO ANY PARTICULAR FONT, STYLE, SIZE, OR COLOR.

OWNER OF AUSTRALIA REG. NO. 1035788, DATED 12-23-2004, EXPIRES 12-23-2014.

**CLASS 19—NON-METALLIC BUILDING MATERIALS**

FOR HEADSTONES MADE OF CONCRETE, STONE, MARBLE AND GRANITE (U.S. CLS. 1, 12, 33 AND 50).

**CLASS 21—HOUSEWARES AND GLASS**

FOR MEMORIAL PLAQUES NOT OF METAL, NAMELY, CHINA, CRYSTAL AND GLASS (U.S. CLS. 2, 13, 23, 29, 30, 33, 40 AND 50).

HANNO RITTNER, EXAMINING ATTORNEY

SN 85-015,874. PUZZLES THAT ROCK, LLC, CHARLEVOIX, MI. FILED 4-16-2010.



THE COLOR(S) WHITE, BLACK, RED, GRAY AND BROWN IS/ARE CLAIMED AS A FEATURE OF THE MARK.

THE MARK CONSISTS OF AN ARRANGEMENT OF PETOSKEY STONES OF VARIOUS SHAPES AND SIZES COLORED IN GRAY, WHITE, BROWN AND BLACK. IN THE TOP CENTER THERE IS A SINGLE RED PETOSKEY STONE. ALL OF THIS IS FEATURED IN A RECTANGULAR BORDER.

**CLASS 16—PAPER GOODS AND PRINTED MATTER**

FOR CALENDARS (U.S. CLS. 2, 5, 22, 23, 29, 37, 38 AND 50).

**CLASS 21—HOUSEWARES AND GLASS**

FOR CUPS, MUGS, DRINKING GLASSES AND PLASTIC AND LEATHER COASTERS (U.S. CLS. 2, 13, 23, 29, 30, 33, 40 AND 50).

**CLASS 28—TOYS AND SPORTING GOODS**

FOR PUZZLES (U.S. CLS. 22, 23, 38 AND 50).  
SIMON TENG, EXAMINING ATTORNEY

SN 85-015,918. 2932105 CANADA INC., MARKHAM, ONTARIO, CANADA, FILED 4-16-2010.



NO CLAIM IS MADE TO THE EXCLUSIVE RIGHT TO USE "DESIGN", APART FROM THE MARK AS SHOWN.

THE MARK CONSISTS OF THE STYLIZED WORDS "EURO" AND "DESIGN" SURROUNDED BY AN OVAL.

**CLASS 14—JEWELRY**

FOR PROMOTIONAL PRODUCTS, NAMELY, WATCHES AND POCKET WATCHES (U.S. CLS. 2, 27, 28 AND 50).

**CLASS 18—LEATHER GOODS**

FOR PROMOTIONAL PRODUCTS, NAMELY, BRIEF CASES, AND DUFFLE BAGS (U.S. CLS. 1, 2, 3, 22 AND 41).

FIRST USE 0-0-2005; IN COMMERCE 0-0-2005.  
FLORENTINA BLANDU, EXAMINING ATTORNEY

SN 85-015,960. WASHINGTON'S TRUSTED LENDER, LLC, RENTON, WA. FILED 4-16-2010.

**REAL ESTATE REEL**

THE MARK CONSISTS OF THE WORDS "REAL ESTATE REEL" IN LOWER CAP LETTERS EXCEPT FOR THE "R" IN THE WORD "REAL", THE "E" IN THE WORD "ESTATE", AND THE "R" IN THE WORD "REEL", WHICH ARE NOTED IN LARGER CAP FONT. THERE IS NO SPACE BETWEEN THE WORDS "REAL" AND "ESTATE" AND "REEL".

**CLASS 36—INSURANCE AND FINANCIAL**

FOR PROVIDING A SEARCHABLE DATABASE OF REAL ESTATE LISTINGS VIA A WEBSITE ON THE INTERNET (U.S. CLS. 100, 101 AND 102).  
FIRST USE 2-12-2010; IN COMMERCE 2-12-2010.

**CLASS 41—EDUCATION AND ENTERTAINMENT**

FOR ON-LINE JOURNALS, NAMELY, BLOGS THAT FEATURE TEXT AND VIDEOS IN THE FIELD OF REAL ESTATE (U.S. CLS. 100, 101 AND 107).  
FIRST USE 2-12-2010; IN COMMERCE 2-12-2010.  
STEVEN R. FINE, EXAMINING ATTORNEY

SN 85-015,974. THE ASAHI SHIMBUN COMPANY, OSAKA-SHI, OSAKA, JAPAN, FILED 4-16-2010.

The Asahi Shimbun

THE MARK CONSISTS OF STANDARD CHARACTERS WITHOUT CLAIM TO ANY PARTICULAR FONT, STYLE, SIZE, OR COLOR.

OWNER OF U.S. REG. NOS. 1,469,044 AND 2,202,816.  
NO CLAIM IS MADE TO THE EXCLUSIVE RIGHT TO USE "SHIMBUN", APART FROM THE MARK AS SHOWN. THE ENGLISH TRANSLATION OF "ASAHI SHIMBUN" IN THE MARK IS RISING SUN NEWSPAPER.

**CLASS 9—ELECTRICAL AND SCIENTIFIC APPARATUS**

FOR DOWNLOADABLE ELECTRONIC PUBLICATIONS IN THE NATURE OF BOOKS, NEWSPAPERS, MAGAZINES OR PERIODICALS IN THE FIELD OF CURRENT EVENT NEWS, SCIENCE, POLITICS, BUSINESS, TECHNOLOGY, ENTERTAINMENT, TRAVEL OR SPORTS (U.S. CLS. 21, 23, 26, 36 AND 38).  
FIRST USE 2-8-2010; IN COMMERCE 2-8-2010.

**CLASS 41—EDUCATION AND ENTERTAINMENT**

FOR NEWSPAPER PUBLISHING (U.S. CLS. 100, 101 AND 107).  
FIRST USE 12-5-1998; IN COMMERCE 12-5-1998.  
LEIGH CAROLINE CASE, EXAMINING ATTORNEY

SN 85-016,803. PERFORMANCE CONTRACTING, INC., LENEXA, KS, FILED 4-19-2010.

PERFORMGREEN

THE COLOR(S) GREEN AND BLACK IS/ARE CLAIMED AS A FEATURE OF THE MARK.

THE MARK CONSISTS OF THE STYLIZED WORDING "PERFORMGREEN". THE TERM "PERFORM" IS IN BLACK, AND THE TERM "GREEN" IS IN GREEN.

**CLASS 35—ADVERTISING AND BUSINESS**

FOR PERFORMING OF INSULATION ENERGY APPRAISALS FOR OTHERS, NAMELY, CONSULTING WITH REGARD TO MEASURING ENERGY SAVINGS AND IMPROVING ENERGY EFFICIENCY (U.S. CLS. 100, 101 AND 102).

**CLASS 37—CONSTRUCTION AND REPAIR**

FOR CONSULTING IN THE FIELD OF ENVIRONMENTALLY-FRIENDLY CONSTRUCTION; INSTALLATION OF ENVIRONMENTALLY-FRIENDLY INSULATION SYSTEM; PROVIDING RECOMMENDATIONS FOR THE INSTALLMENT, REPLACEMENT OR REPAIR OF INSULATION SYSTEMS FOR THE PURPOSE OF IMPROVING ENERGY EFFICIENCY AND REDUCING GREEN HOUSE GAS EMISSIONS (U.S. CLS. 100, 103 AND 106).  
YAT SYE, LEE, EXAMINING ATTORNEY

SN 85-016,946. 4 STIR INC., PALATINE, IL, FILED 4-19-2010.

SPIFTER

THE MARK CONSISTS OF STANDARD CHARACTERS WITHOUT CLAIM TO ANY PARTICULAR FONT, STYLE, SIZE, OR COLOR.

**CLASS 8—HAND TOOLS**

FOR SIFTING SPOONS (U.S. CLS. 23, 28 AND 44).

**CLASS 9—ELECTRICAL AND SCIENTIFIC APPARATUS**

FOR MEASURING CUPS (U.S. CLS. 21, 23, 26, 36 AND 38).  
DEZMONA MIZELLE, EXAMINING ATTORNEY

SN 85-017,498. ALENIA NORTH AMERICA, INC., WASHINGTON, DC, FILED 4-19-2010.

T-100

THE MARK CONSISTS OF STANDARD CHARACTERS WITHOUT CLAIM TO ANY PARTICULAR FONT, STYLE, SIZE, OR COLOR.

**CLASS 9—ELECTRICAL AND SCIENTIFIC APPARATUS**

FOR JET TRAINER AIRPLANE TRAINING SYSTEM COMPONENTS, NAMELY, FLIGHT SIMULATORS, COCKPIT SIMULATORS, AIRCRAFT HANDLING SOFTWARE, INSTRUCTOR OPERATING WORK STATIONS COMPRISED OF COMPUTER HARDWARE, OPERATING AND FLIGHT SIMULATION AND AIRCRAFT HANDLING SOFTWARE, GEO-SPECIFIC DATABASES, TOUCH SCREEN DISPLAYS, AND EMBEDDED TACTICAL TRAINING COMPUTERS (U.S. CLS. 21, 23, 26, 36 AND 38).

**CLASS 12—VEHICLES**

FOR JET TRAINER AIRPLANES AND STRUCTURAL PARTS THEREFOR (U.S. CLS. 19, 21, 23, 31, 35 AND 44).  
DOMINIC J. FERRAIUOLO, EXAMINING ATTORNEY

SN 85-017,995. SAFARI PROGRAMS, INC., MIAMI GARDENS, FL. FILED 4-20-2010.

SN 85-017,624. FENWICK & WEST LLP, MOUNTAIN VIEW, CA. FILED 4-19-2010.

**FLEX**

THE MARK CONSISTS OF STANDARD CHARACTERS WITHOUT CLAIM TO ANY PARTICULAR FONT, STYLE, SIZE, OR COLOR.

**CLASS 35—ADVERTISING AND BUSINESS**

FOR LEGAL OUTSOURCING SERVICES, LEGAL INSOURCING SERVICES (U.S. CLS. 100, 101 AND 102).

**CLASS 45—PERSONAL AND LEGAL SERVICES**

FOR LEGAL SERVICES (U.S. CLS. 100 AND 101).  
JANET LEE, EXAMINING ATTORNEY

SN 85-017,924. ONEENERGY, INC., DBA ONEENERGY RENEWABLES, SEATTLE, WA. FILED 4-20-2010.

**OneEnergy Renewables**

THE MARK CONSISTS OF STANDARD CHARACTERS WITHOUT CLAIM TO ANY PARTICULAR FONT, STYLE, SIZE, OR COLOR.

NO CLAIM IS MADE TO THE EXCLUSIVE RIGHT TO USE "RENEWABLES", APART FROM THE MARK AS SHOWN.

**CLASS 36—INSURANCE AND FINANCIAL**

FOR RENEWABLE ENERGY SERVICES, NAMELY, ENERGY BROKERAGE SERVICES FOR THE PURCHASE, SALE, AND TRADE OF RENEWABLE ENERGY CREDITS AND CARBON OFFSETS; RENEWABLE ENERGY SERVICES, NAMELY, FINANCIAL CONSULTANCY TO HELP DEVELOP RENEWABLE ENERGY PROJECTS; FINANCIAL RESOURCES, NAMELY EQUITY CAPITAL INVESTMENT FOR RENEWABLE ENERGY PROJECTS (U.S. CLS. 100, 101 AND 102).  
FIRST USE 4-1-2010; IN COMMERCE 4-1-2010.

**CLASS 40—MATERIAL TREATMENT**

FOR RENEWABLE ENERGY SERVICES, NAMELY, PROVIDING TECHNICAL CONSULTATION IN THE FIELD OF PRODUCTION OF RENEWABLE ENERGY TO HELP DEVELOP RENEWABLE ENERGY PROJECTS (U.S. CLS. 100, 103 AND 106).

FIRST USE 7-26-2010; IN COMMERCE 7-26-2010.  
INGRID C. EULIN, EXAMINING ATTORNEY

**GOOD LUCK MINIS**

THE MARK CONSISTS OF STANDARD CHARACTERS WITHOUT CLAIM TO ANY PARTICULAR FONT, STYLE, SIZE, OR COLOR.

NO CLAIM IS MADE TO THE EXCLUSIVE RIGHT TO USE "MINIS", APART FROM THE MARK AS SHOWN.

**CLASS 16—PAPER GOODS AND PRINTED MATTER**

FOR (BASED ON INTENT TO USE) PAPER BAGS (U.S. CLS. 2, 5, 22, 23, 29, 37, 38 AND 50).

**CLASS 28—TOYS AND SPORTING GOODS**

FOR (BASED ON USE IN COMMERCE) TOYS, NAMELY, PLASTIC REPLICAS AND FIGURINES (U.S. CLS. 22, 23, 38 AND 50).

FIRST USE 6-1-1998; IN COMMERCE 6-1-1998.  
MARY ROSSMAN, EXAMINING ATTORNEY

SN 85-018,642. MULTIMATIC INC., MARKHAM, ONTARIO, CANADA, FILED 4-20-2010.

**MULTIMATIC**

THE MARK CONSISTS OF STANDARD CHARACTERS WITHOUT CLAIM TO ANY PARTICULAR FONT, STYLE, SIZE, OR COLOR.

OWNER OF CANADA REG. NO. TMA561,275, DATED 5-2-2002, EXPIRES 5-2-2017.

**CLASS 12—VEHICLES**

FOR (BASED ON USE IN COMMERCE) (BASED ON 44(E)) AUTOMOTIVE PARTS, NAMELY, DOOR CHECKERS AND HINGE SYSTEMS FOR SWINGING DOORS, SLIDING DOORS, HOODS, TRUNKS, DECKLIDS, LIFTGATES AND TAILGATES; PICK-UP TRUCK BOX ACCESS STEPS AND TAILGATE STEPS, PICK-UP TRUCK BOX ACCESSORY SYSTEMS AND ACCESSORY RETENTION SYSTEMS, TRUCK BED EXTENDERS, AND TAILGATE LIFT ASSIST DEVICES; DASHBOARD AND CONSOLE STRUCTURAL SYSTEMS, BUMPER BEAMS AND CRASH CANS, VEHICLE BODY AND CHASSIS COMPONENTS; WELDED ASSEMBLIES; SHOCK ABSORBERS, DAMPERS, DAMPER VALVES, CONTROL ARMS, TWIST BEAMS, ANTI-ROLL BAR COMPONENTS, SUB-FRAMES, AND SUSPENSION SYSTEMS; VEHICLE BODY AND CHASSIS SYSTEMS; MECHATRONIC SYSTEMS, NAMELY, AS ACTIVE AERODYNAMIC DEVICES, ACTIVE SUSPENSION ACTUATORS, DOOR ACTUATORS AND WINDSHIELD WIPER SYSTEMS; CARBON FIBRE VEHICLE BODY AND CHASSIS COMPONENTS, AND (BASED ON USE IN COMMERCE) CARBON FIBRE PRODUCTS IN THE CONSUMER PRODUCTS INDUSTRY, NAMELY, STRUCTURAL PARTS FOR MOTORCYCLES, SAILBOATS AND SNOWMOBILES (U.S. CLS. 19, 21, 23, 31, 35 AND 44).  
FIRST USE 5-1-1984; IN COMMERCE 5-1-1984.

**CLASS 40—MATERIAL TREATMENT**

FOR (BASED ON USE IN COMMERCE) (BASED ON 44(E)) PROTOTYPING OF NEW PRODUCTS FOR OTHERS IN THE AUTOMOTIVE, MOTORSPORTS, AEROSPACE, AND CONSUMER PRODUCTS INDUSTRIES (U.S. CLS. 100, 103 AND 106).  
FIRST USE 5-1-1984; IN COMMERCE 5-1-1984.

**CLASS 42—SCIENTIFIC AND COMPUTER SERVICES**

FOR (BASED ON USE IN COMMERCE) (BASED ON 44(E)) ENGINEERING AND DESIGNING SERVICES RELATING TO THE AUTOMOTIVE AND MOTORSPORTS INDUSTRIES (BASED ON USE IN COMMERCE) ENGINEERING AND DESIGNING SERVICES RELATING TO THE AEROSPACE AND CONSUMER PRODUCTS INDUSTRIES; TESTING SERVICES RELATING TO THE AUTOMOTIVE, MOTORSPORTS, AEROSPACE AND CONSUMER PRODUCTS INDUSTRIES; VEHICLE DYNAMICS AND AERODYNAMICS DEVELOPMENT SERVICES FOR AUTOMOTIVE AND MOTORSPORTS APPLICATIONS (U.S. CLS. 100 AND 101).  
FIRST USE 5-1-1984; IN COMMERCE 5-1-1984.  
EDWARD NELSON, EXAMINING ATTORNEY

**CLASS 12—VEHICLES**

FOR (BASED ON USE IN COMMERCE) (BASED ON 44(E)) AUTOMOTIVE PARTS, NAMELY, DOOR CHECKERS AND HINGE SYSTEMS FOR SWINGING DOORS, SLIDING DOORS, HOODS, TRUNKS, DECKLIDS, LIFTGATES AND TAILGATES; PICK-UP TRUCK BOX ACCESS STEPS AND TAILGATE STEPS, PICK-UP TRUCK BOX ACCESSORY SYSTEMS AND ACCESSORY RETENTION SYSTEMS, TRUCK BED EXTENDERS, AND TAILGATE LIFT ASSIST DEVICES; DASHBOARD AND CONSOLE STRUCTURAL SYSTEMS, BUMPER BEAMS AND CRASH CANS, VEHICLE BODY AND CHASSIS COMPONENTS; WELDED ASSEMBLIES; SHOCK ABSORBERS, DAMPERS, DAMPER VALVES, CONTROL ARMS, TWIST BEAMS, ANTI-ROLL BAR COMPONENTS, SUB-FRAMES, AND SUSPENSION SYSTEMS; VEHICLE BODY AND CHASSIS SYSTEMS; MECHATRONIC SYSTEMS, NAMELY, ACTIVE AERODYNAMIC DEVICES, ACTIVE SUSPENSION ACTUATORS, DOOR ACTUATORS AND WINDSHIELD WIPER SYSTEMS; CARBON FIBRE VEHICLE BODY AND CHASSIS COMPONENTS, AND (BASED ON USE IN COMMERCE) CARBON FIBRE PRODUCTS IN THE CONSUMER PRODUCTS INDUSTRY, NAMELY, STRUCTURAL PARTS FOR MOTORCYCLES, SAILBOATS AND SNOWMOBILES (U.S. CLS. 19, 21, 23, 31, 35 AND 44).  
FIRST USE 0-0-1989; IN COMMERCE 0-0-1989.

**CLASS 40—MATERIAL TREATMENT**

FOR (BASED ON USE IN COMMERCE) PROTOTYPING OF NEW PRODUCTS FOR OTHERS IN THE AUTOMOTIVE, MOTORSPORTS, AEROSPACE, AND CONSUMER PRODUCTS INDUSTRIES (U.S. CLS. 100, 103 AND 106).  
FIRST USE 0-0-1989; IN COMMERCE 0-0-1989.

**CLASS 42—SCIENTIFIC AND COMPUTER SERVICES**

FOR (BASED ON USE IN COMMERCE) (BASED ON 44(E)) ENGINEERING SERVICES RELATING TO THE AUTOMOTIVE AND MOTORSPORTS INDUSTRIES (BASED ON USE IN COMMERCE) ENGINEERING SERVICES RELATING TO THE AEROSPACE AND CONSUMER PRODUCTS INDUSTRIES; DESIGNING AND TESTING SERVICES RELATING TO THE AUTOMOTIVE, MOTORSPORTS, AEROSPACE AND CONSUMER PRODUCTS INDUSTRIES; VEHICLE DYNAMICS AND AERODYNAMICS DEVELOPMENT SERVICES FOR AUTOMOTIVE AND MOTORSPORTS APPLICATIONS (U.S. CLS. 100 AND 101).  
FIRST USE 0-0-1989; IN COMMERCE 0-0-1989.  
EDWARD NELSON, EXAMINING ATTORNEY

SN 85-018,662. MULTIMATIC INC., MARKHAM, ONTARIO, CANADA, FILED 4-20-2010.



SN 85-018,681. MULTIMATIC INC., MARKHAM, ONTARIO, CANADA, FILED 4-20-2010.

**STRENGTH THROUGH TECHNOLOGY**

OWNER OF CANADA REG. NO. TMA438,754, DATED 2-3-1995, EXPIRES 2-3-2025.  
OWNER OF U.S. REG. NOS. 1,885,956 AND 1,885,957.  
THE MARK CONSISTS OF A DESIGN COMPRISED OF A STYLIZED MALE HUMAN FIGURE WITHIN AN OVERSIZED GEAR.

THE MARK CONSISTS OF STANDARD CHARACTERS WITHOUT CLAIM TO ANY PARTICULAR FONT, STYLE, SIZE, OR COLOR.  
OWNER OF CANADA REG. NO. TMA444,935, DATED 7-7-1995, EXPIRES 7-7-2025.  
OWNER OF U.S. REG. NOS. 1,884,829 AND 1,885,956.  
NO CLAIM IS MADE TO THE EXCLUSIVE RIGHT TO USE "TECHNOLOGY", APART FROM THE MARK AS SHOWN.



**CLASS 12—VEHICLES**

FOR (BASED ON USE IN COMMERCE) (BASED ON 44(E)) AUTOMOTIVE PARTS, NAMELY, DOOR CHECKERS AND HINGE SYSTEMS FOR SWINGING DOORS, SLIDING DOORS, HOODS, TRUNKS, DECKLIDS, LIFTGATES AND TAILGATES; PICK-UP TRUCK BOX ACCESS STEPS AND TAILGATE STEPS, PICK-UP TRUCK BOX ACCESSORY SYSTEMS AND ACCESSORY RETENTION SYSTEMS, TRUCK BED EXTENDERS, AND TAILGATE LIFT ASSIST DEVICES; DASHBOARD AND CONSOLE STRUCTURAL SYSTEMS, BUMPER BEAMS AND CRASH CANS, VEHICLE BODY AND CHASSIS COMPONENTS; WELDED ASSEMBLIES; SHOCK ABSORBERS, DAMPERS, DAMPER VALVES, CONTROL ARMS, TWIST BEAMS, ANTI-ROLL BAR COMPONENTS, SUB-FRAMES, AND SUSPENSION SYSTEMS; VEHICLE BODY AND CHASSIS SYSTEMS; MECHATRONIC SYSTEMS, NAMELY, ACTIVE AERODYNAMIC DEVICES, ACTIVE SUSPENSION ACTUATORS, DOOR ACTUATORS AND WINDSHIELD WIPER SYSTEMS; CARBON FIBRE VEHICLE BODY AND CHASSIS COMPONENTS, AND (BASED ON USE IN COMMERCE) CARBON FIBRE PRODUCTS IN THE CONSUMER PRODUCTS INDUSTRY, NAMELY, STRUCTURAL PARTS FOR MOTORCYCLES, SAILBOATS AND SNOWMOBILES (U.S. CLS. 19, 21, 23, 31, 35 AND 44).

FIRST USE 0-0-1989; IN COMMERCE 0-0-1989.

**CLASS 40—MATERIAL TREATMENT**

FOR (BASED ON USE IN COMMERCE) PROTOTYPING OF NEW PRODUCTS FOR OTHERS IN THE AUTOMOTIVE, MOTORSPORTS, AEROSPACE, AND CONSUMER PRODUCTS INDUSTRIES (U.S. CLS. 100, 103 AND 106).

FIRST USE 0-0-1989; IN COMMERCE 0-0-1989.

**CLASS 42—SCIENTIFIC AND COMPUTER SERVICES**

FOR (BASED ON USE IN COMMERCE) (BASED ON 44(E)) ENGINEERING SERVICES RELATING TO THE AUTOMOTIVE AND MOTORSPORTS INDUSTRIES (BASED ON USE IN COMMERCE) ENGINEERING SERVICES RELATING TO THE AEROSPACE AND CONSUMER PRODUCTS INDUSTRIES; DESIGNING AND TESTING SERVICES RELATING TO THE AUTOMOTIVE, MOTORSPORTS, AEROSPACE AND CONSUMER PRODUCTS INDUSTRIES; VEHICLE DYNAMICS AND AERODYNAMICS DEVELOPMENT SERVICES FOR AUTOMOTIVE AND MOTORSPORTS APPLICATIONS (U.S. CLS. 100 AND 101).

FIRST USE 0-0-1989; IN COMMERCE 0-0-1989.

EDWARD NELSON, EXAMINING ATTORNEY

**CLASS 9—ELECTRICAL AND SCIENTIFIC APPARATUS**

FOR DOWNLOADABLE CONTENT, NAMELY, MUSICAL PERFORMANCES, MUSICAL VIDEOS, RELATED FILM CLIPS AND PHOTOGRAPHS, PRERECORDED MUSIC, WRITTEN MATERIALS IN THE FIELD OF MUSIC, INCLUDING COMMENTARY AND ARTICLES ABOUT MUSIC, ALL ONLINE VIA A GLOBAL COMPUTER NETWORK (U.S. CLS. 21, 23, 26, 36 AND 38).

**CLASS 41—EDUCATION AND ENTERTAINMENT**

FOR RECORD PRODUCTION; MUSIC PRODUCTION; AUDIO RECORDING AND PRODUCTION; VIDEOTAPE PRODUCTION; MOTION PICTURE SONG PRODUCTION; PRODUCTION OF VIDEO DISCS FOR OTHERS; RECORDING STUDIOS; ENTERTAINMENT SERVICES, NAMELY, PRODUCTION AND DISTRIBUTION OF MUSICAL AUDIO AND VIDEO PROGRAMS; PRODUCTION AND DISTRIBUTION OF MUSICAL AUDIO AND VIDEO RECORDINGS FOR BROADCAST; MUSIC COMPOSITION AND TRANSCRIPTION FOR OTHERS; SONG WRITING SERVICES; MUSIC PUBLISHING SERVICES; ENTERTAINMENT IN THE NATURE OF A LIVE MUSICAL BAND OR MUSICAL GROUP; ENTERTAINMENT IN THE NATURE OF LIVE PERFORMANCES BY A MUSICAL GROUP OR MUSICAL BAND; ENTERTAINMENT, NAMELY, LIVE MUSIC CONCERTS; ENTERTAINMENT, NAMELY, PERSONAL APPEARANCES BY A MUSICAL GROUP OR MUSICAL BAND; ENTERTAINMENT SERVICES, NAMELY, PROVIDING A WEB SITE FEATURING NON-DOWNLOADABLE MUSICAL PERFORMANCES, MUSICAL VIDEOS, RELATED FILM CLIPS, AND PHOTOGRAPHS; ENTERTAINMENT SERVICES, NAMELY, PROVIDING NON-DOWNLOADABLE PRERECORDED MUSIC, INFORMATION IN THE FIELD OF MUSIC, COMMENTARY AND ARTICLES ABOUT MUSIC, ALL ONLINE VIA A GLOBAL COMPUTER NETWORK; TELEVISION SHOW PRODUCTION; CABLE TELEVISION SHOW PRODUCTION; RADIO ENTERTAINMENT PRODUCTION; MOTION PICTURE FILM PRODUCTION; PROVISION OF NON-DOWNLOADABLE FILMS AND TELEVISION PROGRAMS VIA A VIDEO-ON-DEMAND SERVICE; ENTERTAINMENT IN THE NATURE OF ON-GOING TELEVISION, CABLE TELEVISION AND RADIO PROGRAMS FEATURING MUSIC AND SPOKEN WORD; THEATRE PRODUCTIONS; ENTERTAINMENT IN THE NATURE OF LIVE TRAVELING TOURS BY A PROFESSIONAL ENTERTAINMENT GROUP FEATURING MUSIC AND SPOKEN WORD; ENTERTAINMENT SERVICES, NAMELY, PRESENTING NON-DOWNLOADABLE RINGTONES, PRE-RECORDED MUSIC, VIDEO AND GRAPHICS TO MOBILE COMMUNICATIONS DEVICES VIA A GLOBAL COMPUTER NETWORK AND WIRELESS NETWORKS (U.S. CLS. 100, 101 AND 107).

NICHOLAS ALTREE, EXAMINING ATTORNEY

SN 85-018,726. GLASSJAW, NEW YORK, NY. FILED 4-20-2010.



THE MARK CONSISTS OF A STYLIZED DEPICTION OF THE LETTERS "G" AND "J".

SN 85-018,894. DELTAK EDU, INC., BURR RIDGE, IL. FILED 4-20-2010.

DELTAK

THE MARK CONSISTS OF STANDARD CHARACTERS WITHOUT CLAIM TO ANY PARTICULAR FONT, STYLE, SIZE, OR COLOR.

**CLASS 35—ADVERTISING AND BUSINESS**

FOR CONSULTING SERVICES IN THE FIELDS OF HIGHER EDUCATION ADMINISTRATION AND RECRUITMENT OF STUDENTS FOR HIGHER EDUCATION INSTITUTIONS; CONSULTING SERVICES IN THE FIELD OF HIGHER EDUCATION, NAMELY, ASSISTING COLLEGE AND UNIVERSITIES IN FINDING STUDENTS THROUGH ADVERTISING AND RECRUITMENT; HIGHER EDUCATION CONSULTING SERVICES IN THE FIELD OF STUDENT AND ALUMNI RETENTION (U.S. CLS. 100, 101 AND 102).

**CLASS 41—EDUCATION AND ENTERTAINMENT**

FOR CONSULTING SERVICES IN THE FIELD OF DEVELOPING CURRICULUM FOR HIGHER EDUCATION INSTITUTIONS AND FACULTY; HIGHER EDUCATION CONSULTING SERVICES, NAMELY, ASSISTING STUDENTS WITH COMPLETING THE COLLEGE AND UNIVERSITY APPLICATION PROCESS (U.S. CLS. 100, 101 AND 107).

NATALIE POLZER, EXAMINING ATTORNEY

SN 85-019,059. THOMAS A. BRADY SPORTS MEDICINE CENTER, P.C., INDIANAPOLIS, IN. FILED 4-21-2010.



NO CLAIM IS MADE TO THE EXCLUSIVE RIGHT TO USE "INDIANA SPORTS CONCUSSION NETWORK", APART FROM THE MARK AS SHOWN.

THE MARK CONSISTS OF STYLIZED DRAWING OF THE OUTLINE OF THE STATE OF INDIANA WITH A STYLIZED DRAWING OF THE HUMAN BRAIN IN THE MIDDLE OF THE STATE. THE WORDS "INDIANA SPORTS CONCUSSION NETWORK" ARE PLACED AT RIGHT OF THE DESIGN.

**CLASS 35—ADVERTISING AND BUSINESS**

FOR PROMOTING PUBLIC AWARENESS OF THE RISKS OF SPORTS RELATED CONCUSSIONS AND THE IMPORTANCE OF PROPER MANAGEMENT OF SPORTS RELATED CONCUSSIONS (U.S. CLS. 100, 101 AND 102).

FIRST USE 5-31-2008; IN COMMERCE 5-31-2008.

**CLASS 41—EDUCATION AND ENTERTAINMENT**

FOR EDUCATION SERVICES, NAMELY, PROVIDING CLASSES, SEMINARS AND WORKSHOPS IN THE FIELD OF MEDICAL CARE OF SPORTS RELATED HEAD INJURIES (U.S. CLS. 100, 101 AND 107).

FIRST USE 4-21-2009; IN COMMERCE 4-21-2009.

**CLASS 44—MEDICAL, BEAUTY AND AGRICULTURAL SERVICES**

FOR MEDICAL SERVICES, NAMELY, TREATMENT CARE OF PATIENTS WHO HAVE SUFFERED FROM SPORTS RELATED HEAD INJURIES, AND PRE-INJURY BASELINE TESTING FOR PARTICIPANTS IN SPORTING ACTIVITIES (U.S. CLS. 100 AND 101).

FIRST USE 5-31-2008; IN COMMERCE 5-31-2008.  
CHARLOTTE CORWIN, EXAMINING ATTORNEY

SN 85-019,073. KARMA FOR YOU, LLC, BRYN MAWR, PA. FILED 4-21-2010.



THE MARK CONSISTS OF THE WORDS "FOR THE LONG RUN KARMA STRIDERS" INSIDE A CRESCENT MOON.

**CLASS 25—CLOTHING**

FOR BASEBALL CAPS AND HATS; T-SHIRTS (U.S. CLS. 22 AND 39).

**CLASS 41—EDUCATION AND ENTERTAINMENT**

FOR ORGANIZING AND CONDUCTING A RUNNING EVENT THE PROCEEDS OF WHICH ARE DONATED TO CHARITY (U.S. CLS. 100, 101 AND 107).

SANJEEV VOHRA, EXAMINING ATTORNEY

SN 85-019,850. NATURE'S BEST, BREA, CA. FILED 4-21-2010.

**CADIA**

THE MARK CONSISTS OF STANDARD CHARACTERS WITHOUT CLAIM TO ANY PARTICULAR FONT, STYLE, SIZE, OR COLOR.

THE WORDING "CADIA" HAS NO MEANING IN A FOREIGN LANGUAGE.

**CLASS 3—COSMETICS AND CLEANING PREPARATIONS**

FOR LAUNDRY DETERGENTS; ALL PURPOSE CLEANERS; BODY SOAP, BEAUTY CREAMS FOR BODY CARE; DEODORANTS FOR BODY CARE; LOTIONS FOR FACE AND BODY CARE; PERSONAL HAIR CARE PRODUCTS, NAMELY, SHAMPOOS, CONDITIONERS AND HAIR STYLING PREPARATIONS (U.S. CLS. 1, 4, 6, 50, 51 AND 52).

**CLASS 5—PHARMACEUTICALS**

FOR NUTRITIONAL VITAMINS AND SUPPLEMENTS; CEREAL-BASED MEAL REPLACEMENT BARS; GRANOLA-BASED MEAL REPLACEMENT BARS (U.S. CLS. 6, 18, 44, 46, 51 AND 52).

SN 85-020,575. GHOZO LLC, NEW YORK, NY. AND STRANGE MATTER VENTURES, LLC, NEW YORK, NY. FILED 4-22-2010.

**CLASS 16—PAPER GOODS AND PRINTED MATTER**

FOR PAPER PRODUCTS, NAMELY, TOILET TISSUE, PAPER TOWELS, NAPKINS, FACIAL TISSUE, LUNCH BAGS (U.S. CLS. 2, 5, 22, 23, 29, 37, 38 AND 50).

TINY'S GIANT SANDWICH SHOP

**CLASS 21—HOUSEWARES AND GLASS**

FOR PAPER DINNERWARE, PAPER CUPS (U.S. CLS. 2, 13, 23, 29, 30, 33, 40 AND 50).

THE MARK CONSISTS OF STANDARD CHARACTERS WITHOUT CLAIM TO ANY PARTICULAR FONT, STYLE, SIZE, OR COLOR.

NO CLAIM IS MADE TO THE EXCLUSIVE RIGHT TO USE "SANDWICH SHOP", APART FROM THE MARK AS SHOWN.

**CLASS 29—MEATS AND PROCESSED FOODS**

FOR DAIRY PRODUCTS, NAMELY, MILK, BUTTER, CREAM, YOGURT, CHEESE, KEFIR, SOUR CREAM AND COTTAGE CHEESE; MILK SUBSTITUTES, NAMELY, SOY MILK, RICE MILK, HEMP MILK, ALMOND MILK.; TUNA, BROTHS, EGGS, OLIVE OIL, CANOLA OIL, VEGETABLE OIL, NUT BUTTERS, CRANBERRY SAUCE AND APPLESAUCE, PROCESSED FRUIT-BASED FOOD BARS, FRUIT PRESERVES, FROZEN FRUIT, CANNED TOMATOES, CANNED BEANS, FROZEN VEGETABLES, DRIED BEANS, CANNED VEGETABLES, CANNED AND REFRIGERATED SOUPS; TRAIL MIX CONSISTING PRIMARILY OF PROCESSED NUTS, SEEDS AND DRIED FRUIT AND ALSO INCLUDING CHOCOLATE; FROZEN ENTREES CONSISTING PRIMARILY OF MEAT, FISH, POULTRY OR VEGETABLES; PICKLES, JARRED PEPPERS, FROZEN MEAT, VEGETABLE-BASED MEAT SUBSTITUTES, REFRIGERATED MEAT; DAIRY-BASED DIP; BEAN DIP, POTATO CHIPS, VEGETABLE CHIPS; PROCESSED, ROASTED AND SHELLED NUTS; FROZEN BREAKFAST ITEMS, NAMELY, SAUSAGES AND BACON (U.S. CL. 46).

**CLASS 30—STAPLE FOODS**

FOR SANDWICHES (U.S. CL. 46).  
FIRST USE 1-1-2000; IN COMMERCE 1-1-2000.

**CLASS 39—TRANSPORTATION AND STORAGE**

FOR DELIVERY OF FOOD BY RESTAURANTS; FOOD DELIVERY (U.S. CLS. 100 AND 105).  
FIRST USE 1-1-2000; IN COMMERCE 1-1-2000.

**CLASS 43—HOTEL AND RESTAURANT SERVICES**

FOR CATERING OF FOOD AND DRINKS; RESTAURANT SERVICES FEATURING SANDWICHES; RESTAURANT SERVICES, INCLUDING SIT-DOWN SERVICE OF FOOD AND TAKE-OUT RESTAURANT SERVICES; RESTAURANT SERVICES, NAMELY, PROVIDING OF FOOD AND BEVERAGES FOR CONSUMPTION ON AND OFF THE PREMISES; SERVING OF FOOD AND DRINK/BEVERAGES (U.S. CLS. 100 AND 101).

FIRST USE 1-1-2000; IN COMMERCE 1-1-2000.  
ROBERT STRUCK, EXAMINING ATTORNEY

**CLASS 30—STAPLE FOODS**

FOR PASTA SAUCE, SALSA, KETCHUP, MUSTARD, MAYONNAISE, VINEGAR, ASIAN SAUCES, SALAD DRESSING, RELISH, TORTILLA CHIPS, POPCORN, PASTA, READY-TO-EAT CEREALS, DRIED RICE, MACARONI AND CHEESE, PRETZELS, COOKIES, CRACKERS, READY TO EAT CEREAL-BASED FOOD BARS, READY TO EAT GRANOLA-BASED FOOD BARS, FROZEN BREAKFAST ITEMS, NAMELY, BURRITOS, PANCAKES, WAFFLES AND SANDWICHES; NATURAL SWEETENERS, NAMELY, AGAVE, HONEY, SUGAR; FROZEN DAIRY-BASED DESSERTS, FROZEN FRUIT-BASED DESSERTS; FROZEN FRUIT AND DAIRY-BASED DESSERTS; FROZEN PIZZAS, FROZEN BREAD, MIXES FOR BAKERY GOODS, TEA, COFFEE; FRUIT ICE BARS; TRAIL MIX CONSISTING PRIMARILY OF CANDIES AND CHOCOLATES, AND ALSO CONTAINING PROCESSED NUTS AND FRUIT; FROZEN ENTREES CONSISTING PRIMARILY OF PASTA OR RICE, FRUIT SAUCES EXCLUDING CRANBERRY AND APPLESAUCE (U.S. CL. 46).

SN 85-020,764. SAND DUNE VENTURES, INC., TORRANCE, CA. FILED 4-22-2010.

**CLASS 31—NATURAL AGRICULTURAL PRODUCTS**

FOR FRESH FRUITS AND VEGETABLES, RAW NUTS (U.S. CLS. 1 AND 46).

TABLETKIOSK

**CLASS 32—LIGHT BEVERAGES**

FOR SODA POPS, SODA WATER, FLAVORED WATER, REFRIGERATED CITRUS JUICE, SPORTS DRINKS, ENERGY DRINKS, COCONUT MILK, FRUIT JUICES (U.S. CLS. 45, 46 AND 48).

CHRISTINE COOPER, EXAMINING ATTORNEY

THE MARK CONSISTS OF STANDARD CHARACTERS WITHOUT CLAIM TO ANY PARTICULAR FONT, STYLE, SIZE, OR COLOR.

OWNER OF U.S. REG. NO. 3,266,873.  
SEC. 2(F).

**CLASS 9—ELECTRICAL AND SCIENTIFIC APPARATUS**

FOR COMPUTER ACCESSORIES, NAMELY, MOUNTS FOR MONITORS, COMPUTER CARRYING BAGS, BATTERY CHARGERS, BATTERIES, OPTICAL CD-ROM AND DVD DRIVES, DOCKING STATIONS, PRESENTATION STANDS, KEYBOARDS, MOUSE, STYLUSES, RUBBER PROTECTIVE BUMPERS, CABLES, CAR ADAPTORS COMPUTER ACCESSORIES, NAMELY, MOUNTS FOR MONITORS, COMPUTER CARRYING BAGS, BATTERY CHARGERS, BATTERIES, OPTICAL CD-ROM AND DVD DRIVES, DOCKING STATIONS, PRESENTATION STANDS, KEYBOARDS, MOUSE, STYLUSES, RUBBER PROTECTIVE BUMPERS, CABLES, CAR ADAPTORS (U.S. CLS. 21, 23, 26, 36 AND 38).

FIRST USE 12-0-2003; IN COMMERCE 12-0-2003.

**CLASS 35—ADVERTISING AND BUSINESS**

FOR ONLINE RETAIL STORE FEATURING, COMPUTERS, MOBILE AND TABLET PCS, TOUCH SCREEN COMPUTER KIOSKS, INDUSTRIAL PCS, AND FEATURING COMPUTER ACCESSORIES, NAMELY, MOUNTS FOR MONITORS, COMPUTER CARRYING BAGS, BATTERY CHARGERS, BATTERIES, OPTICAL CD-ROM AND DVD DRIVES, DOCKING STATIONS, PRESENTATION STANDS, KEYBOARDS, MOUSE, STYLUSES, RUBBER PROTECTIVE BUMPERS, CABLES, CARE ADAPTORS (U.S. CLS. 100, 101 AND 102).

FIRST USE 12-0-2003; IN COMMERCE 12-0-2003.

**CLASS 40—MATERIAL TREATMENT**

FOR MANUFACTURE OF COMPUTER TOUCH SCREEN KIOSKS, AND INDUSTRIAL PCS TO ORDER AND/OR SPECIFICATION OF OTHERS (U.S. CLS. 100, 103 AND 106).

FIRST USE 12-0-2003; IN COMMERCE 12-0-2003.

**CLASS 42—SCIENTIFIC AND COMPUTER SERVICES**

FOR DESIGN OF AND CONSULTATION REGARDING DESIGN OF COMPUTERS FOR OTHERS; DESIGN OF AND CONSULTATION REGARDING DESIGN OF TOUCH SCREEN KIOSKS FOR OTHERS (U.S. CLS. 100 AND 101).

FIRST USE 12-0-2003; IN COMMERCE 12-0-2003.  
CHRISTINA SOBRAL, EXAMINING ATTORNEY

SN 85-021,509. NEWPAGE CORPORATION, MIAMISBURG, OH. FILED 4-23-2010.

ED

THE MARK CONSISTS OF STANDARD CHARACTERS WITHOUT CLAIM TO ANY PARTICULAR FONT, STYLE, SIZE, OR COLOR.

OWNER OF U.S. REG. NO. 2,777,443.

**CLASS 40—MATERIAL TREATMENT**

FOR PROVIDING INFORMATION REGARDING COMMERCIAL PRINTING, COMMERCIAL PRINTING TECHNIQUES AND TERMINOLOGY, COMMERCIAL PRINTING PRESSES AND EQUIPMENT, COMMERCIAL PRINTING PROCESSES, COMMERCIAL PRINTING PAPERS, DIGITAL PRINTING, COMMERCIAL DESIGN PRINTING (U.S. CLS. 100, 103 AND 106).

FIRST USE 0-0-2008; IN COMMERCE 0-0-2008.

**CLASS 42—SCIENTIFIC AND COMPUTER SERVICES**

FOR PROVIDING INFORMATION REGARDING DESIGN FOR COMMERCIAL PRINTING APPLICATIONS AND ENVIRONMENTAL SUSTAINABILITY MEASURES OF THE PRINTING PROCESS (U.S. CLS. 100 AND 101).

FIRST USE 0-0-2008; IN COMMERCE 0-0-2008.  
WILLIAM VERHOSEK, EXAMINING ATTORNEY

SN 85-021,516. NEWPAGE CORPORATION, MIAMISBURG, OH. FILED 4-23-2010.



OWNER OF U.S. REG. NOS. 2,777,443, 3,209,662 AND OTHERS.

NO CLAIM IS MADE TO THE EXCLUSIVE RIGHT TO USE "EDUCATION", APART FROM THE MARK AS SHOWN.

THE MARK CONSISTS OF THE WORDS "ED NEWPAGE & EDUCATION" WITH "ED" INSIDE A BOX AND "NEWPAGE" AND "& EDUCATION" BELOW THE BOX.

**CLASS 40—MATERIAL TREATMENT**

FOR PROVIDING INFORMATION REGARDING COMMERCIAL PRINTING, COMMERCIAL PRINTING TECHNIQUES AND TERMINOLOGY, COMMERCIAL PRINTING PRESSES AND EQUIPMENT, COMMERCIAL PRINTING PROCESSES, COMMERCIAL PRINTING PAPERS, DIGITAL PRINTING, COMMERCIAL DESIGN PRINTING (U.S. CLS. 100, 103 AND 106).

FIRST USE 0-0-2008; IN COMMERCE 0-0-2008.

**CLASS 42—SCIENTIFIC AND COMPUTER SERVICES**

FOR PROVIDING INFORMATION REGARDING DESIGN FOR COMMERCIAL PRINTING APPLICATIONS AND ENVIRONMENTAL SUSTAINABILITY MEASURES OF THE PRINTING PROCESS (U.S. CLS. 100 AND 101).

FIRST USE 0-0-2008; IN COMMERCE 0-0-2008.  
WILLIAM VERHOSEK, EXAMINING ATTORNEY

SN 85-021,616. EQUINOME LIMITED, COOLCULLEN, IRELAND, FILED 4-23-2010.

# EQUINOME

THE MARK CONSISTS OF STANDARD CHARACTERS WITHOUT CLAIM TO ANY PARTICULAR FONT, STYLE, SIZE, OR COLOR.

PRIORITY CLAIMED UNDER SEC. 44(D) ON ERPNCMNTY TM OFC APPLICATION NO. 008746141, FILED 12-10-2009, REG. NO. 008746141, DATED 6-11-2010, EXPIRES 12-10-2019.

## CLASS 9—ELECTRICAL AND SCIENTIFIC APPARATUS

FOR LABORATORY DEVICES, NAMELY, DNA COLLECTION AND STORAGE APPARATUS (U.S. CLS. 21, 23, 26, 36 AND 38).

## CLASS 10—MEDICAL APPARATUS

FOR VETERINARY AND MEDICAL DEVICES, NAMELY, DNA COLLECTION AND STORAGE APPARATUS (U.S. CLS. 26, 39 AND 44).

## CLASS 44—MEDICAL, BEAUTY AND AGRICULTURAL SERVICES

FOR GENETIC TESTING FOR MEDICAL PURPOSES, GENETIC TESTING OF ANIMALS, PROVIDING INFORMATION IN THE FIELD OF ANIMAL BREEDING, NAMELY, HORSES (U.S. CLS. 100 AND 101).  
JANICE KIM, EXAMINING ATTORNEY

SN 85-021,923. THOMSON REUTERS (CANADA) LIMITED, TORONTO, CANADA, FILED 4-23-2010.

# THOMSON REUTERS ELEKTRON

THE MARK CONSISTS OF STANDARD CHARACTERS WITHOUT CLAIM TO ANY PARTICULAR FONT, STYLE, SIZE, OR COLOR.

## CLASS 9—ELECTRICAL AND SCIENTIFIC APPARATUS

FOR COMPUTER SOFTWARE PROGRAM, NAMELY, DATA DELIVERY SOLUTION FOR USE BY FINANCIAL PROFESSIONALS FOR USE IN TRADING STOCKS AND BONDS, THE COLLECTION AND DISTRIBUTION OF FINANCIAL DATA, SHARE DEALING, STOCK DEALING, FINANCIAL TRANSACTIONS, FISCAL ASSESSMENTS (U.S. CLS. 21, 23, 26, 36 AND 38).

## CLASS 36—INSURANCE AND FINANCIAL

FOR FINANCIAL ADVISORY AND CONSULTANCY SERVICES TO FINANCIAL PROFESSIONALS IN THE FIELDS OF TRADING STOCKS AND BONDS, THE COLLECTION AND DISTRIBUTION OF FINANCIAL DATA, SHARE DEALING, STOCK DEALING, FINANCIAL TRANSACTIONS, PROVISION OF FINANCIAL NEWS AND INFORMATION; FINANCIAL CONSULTANCY; FISCAL ASSESSMENTS; NEWS REPORTING SERVICES IN THE FIELD OF FINANCIAL NEWS (U.S. CLS. 100, 101 AND 102).

## CLASS 38—COMMUNICATION

FOR PROVIDING MULTIPLE-USER ACCESS TO A GLOBAL COMPUTER INFORMATION NETWORK; PROVIDING ACCESS TO DATABASES (U.S. CLS. 100, 101 AND 104).

## CLASS 41—EDUCATION AND ENTERTAINMENT

FOR NEWS AGENCIES, NAMELY, GATHERING AND DISSEMINATION OF NEWS; NEWS SYNDICATING REPORTING; PROVISION OF NEWS AND CURRENT AFFAIRS INFORMATION REPORTING (U.S. CLS. 100, 101 AND 107).

## CLASS 42—SCIENTIFIC AND COMPUTER SERVICES

FOR RENTAL OF COMPUTERS; COMPUTER SOFTWARE DESIGN FOR OTHERS; UPDATING OF COMPUTER SOFTWARE FOR OTHERS; NEWS REPORTING SERVICES; RENTAL OF COMPUTER SOFTWARE (U.S. CLS. 100 AND 101).  
CYNTHIA SLOAN, EXAMINING ATTORNEY

SN 85-022,928. AB MAURI FOOD, INC., FENTON, MO. FILED 4-26-2010.

# SOLUTIONS FOR BAKING SUCCESS

THE MARK CONSISTS OF STANDARD CHARACTERS WITHOUT CLAIM TO ANY PARTICULAR FONT, STYLE, SIZE, OR COLOR.

## CLASS 1—CHEMICALS

FOR HOUSE MARK FOR CHEMICAL FOOD ADDITIVES, PRESERVATIVES AND INGREDIENTS USED IN THE MANUFACTURE OF BAKERY GOODS, NAMELY, DOUGH IMPROVERS, DOUGH LEAVENERS, MOLD INHIBITORS, ACIDULANTS, MINERAL SALTS, GUMS, OXIDATION AGENTS, AND ENZYME TABLETS (U.S. CLS. 1, 5, 6, 10, 26 AND 46).  
FIRST USE 9-1-2009; IN COMMERCE 9-1-2009.

## CLASS 30—STAPLE FOODS

FOR YEAST, CORN SYRUPS, MALT SYRUPS FOR FOOD PURPOSES, FLOUR, SUGAR, VINEGAR, MOLASSES, BAKING POWDER, BAKING SODA (U.S. CL. 46).  
FIRST USE 9-1-2009; IN COMMERCE 9-1-2009.  
BRIAN NEVILLE, EXAMINING ATTORNEY

SN 85-023,208. AIRBED & BREAKFAST, INC., SAN FRANCISCO, CA. FILED 4-26-2010.

# AIRBNB

THE MARK CONSISTS OF STANDARD CHARACTERS WITHOUT CLAIM TO ANY PARTICULAR FONT, STYLE, SIZE, OR COLOR.

## CLASS 39—TRANSPORTATION AND STORAGE

FOR ONLINE TRIP AND TRAVEL RECOMMENDATIONS AND RESERVATION SERVICES; PROVIDING TRAVEL INFORMATION OVER GLOBAL COMPUTER NETWORKS, NAMELY, PROVIDING SEARCH SERVICES FOR TRAVEL LISTINGS, TRAVEL INFORMATION AND RELATED TOPICS AND FOR MAKING RESERVATIONS AND BOOKINGS FOR TRANSPORTATION; PROVIDING REVIEWS AND RECOMMENDATIONS OF LOCAL ATTRACTIONS VIA A GLOBAL COMPUTER NETWORK; LISTING, ARRANGING AND RESERVATION SERVICES FOR THE SHARING OF VEHICLES AND RIDES AMONG VEHICLE OWNERS AND INDIVIDUALS SEEKING TRANSPORTATION, OVER A GLOBAL COMPUTER NETWORK; LISTING, ARRANGING AND RESERVATION SERVICES FOR THE TEMPORARY PARKING OF VEHICLES AT RESIDENCES OR BUSINESSES BY VEHICLE OWNERS SEEKING PARKING, OVER A GLOBAL COMPUTER NETWORK; PROVIDING A WEBSITE FEATURING INFORMATION LISTINGS AND BOOKINGS OF CAR SHARING AND TEMPORARY PARKING SERVICES; PROVIDING A WEB SITE FEATURING LISTINGS AND INFORMATION CONCERNING PEER-TO-PEER TRANSPORTATION SERVICES (U.S. CLS. 100 AND 105).

## CLASS 43—HOTEL AND RESTAURANT SERVICES

FOR PROVIDING TRAVEL INFORMATION OVER GLOBAL COMPUTER NETWORKS, NAMELY, PROVIDING SEARCH SERVICES FOR TRAVEL LISTINGS, TRAVEL INFORMATION AND RELATED TOPICS AND FOR MAKING RESERVATIONS AND BOOKINGS FOR LODGING (U.S. CLS. 100 AND 101).

GIANCARLO CASTRO, EXAMINING ATTORNEY

SN 85-023,271. EFX PERFORMANCE, INC., MISSION VIEJO, CA. FILED 4-26-2010.

# EFX

THE MARK CONSISTS OF STANDARD CHARACTERS WITHOUT CLAIM TO ANY PARTICULAR FONT, STYLE, SIZE, OR COLOR.

OWNER OF U.S. REG. NOS. 7,781,371, 7,785,895 AND 7,785,933.

## CLASS 25—CLOTHING

FOR WRISTBANDS (U.S. CLS. 22 AND 39).  
FIRST USE 3-1-2008; IN COMMERCE 3-1-2008.

## CLASS 45—PERSONAL AND LEGAL SERVICES

FOR INTERNET BASED SOCIAL NETWORKING SERVICES (U.S. CLS. 100 AND 101).

FIRST USE 3-1-2008; IN COMMERCE 3-1-2008.

LINDA MICKLEBURGH, EXAMINING ATTORNEY

SN 85-023,360. EFX PERFORMANCE, INC., MISSION VIEJO, CA. FILED 4-26-2010.

# EFX PERFORMANCE

THE MARK CONSISTS OF STANDARD CHARACTERS WITHOUT CLAIM TO ANY PARTICULAR FONT, STYLE, SIZE, OR COLOR.

OWNER OF U.S. REG. NOS. 7,781,371, 7,785,895 AND 7,785,933.

## CLASS 14—JEWELRY

FOR JEWELRY, BRACELETS, NECKLACE, ANKLE BRACELETS (U.S. CLS. 2, 27, 28 AND 50).

FIRST USE 3-1-2008; IN COMMERCE 3-1-2008.

## CLASS 25—CLOTHING

FOR WRISTBANDS (U.S. CLS. 22 AND 39).

FIRST USE 3-1-2008; IN COMMERCE 3-1-2008.

LINDA MICKLEBURGH, EXAMINING ATTORNEY

SN 85-023,458. FRESHTECH, INC., EL SEGUNDO, CA. FILED 4-26-2010.

# SUPREME STEAM

THE MARK CONSISTS OF STANDARD CHARACTERS WITHOUT CLAIM TO ANY PARTICULAR FONT, STYLE, SIZE, OR COLOR.

NO CLAIM IS MADE TO THE EXCLUSIVE RIGHT TO USE "STEAM", APART FROM THE MARK AS SHOWN.

## CLASS 16—PAPER GOODS AND PRINTED MATTER

FOR PLASTIC BAGS AND POUCHES FOR STEAM COOKING; PLASTIC FILMS AND FLEXIBLE PLASTIC FILM FOR HOME STEAM COOKING USE (U.S. CLS. 2, 5, 22, 23, 29, 37, 38 AND 50).

## CLASS 20—FURNITURE AND ARTICLES NOT OTHERWISE CLASSIFIED

FOR PLASTIC TRAY LIDDING USED AS PACKAGING FOR STEAM COOKING APPLICATIONS (U.S. CLS. 2, 13, 22, 25, 32 AND 50).

KIMBERLY FRYE, EXAMINING ATTORNEY

SN 85-023,780. E & G FRANCHISE SYSTEMS, INC., EAU CLAIRE, WI. FILED 4-27-2010.

SN 85-024,354. MEXICANA DE CANANEA, S.A. DE C.V., CANANEA, SONORA, MEXICO, FILED 4-27-2010.

## Erbert & Gerbert's Sandwich Shop

THE MARK CONSISTS OF STANDARD CHARACTERS WITHOUT CLAIM TO ANY PARTICULAR FONT, STYLE, SIZE, OR COLOR.

NO CLAIM IS MADE TO THE EXCLUSIVE RIGHT TO USE "SANDWICH SHOP", APART FROM THE MARK AS SHOWN.

THE NAME(S), PORTRAIT(S), AND/OR SIGNATURE(S) SHOWN IN THE MARK DOES NOT IDENTIFY A PARTICULAR LIVING INDIVIDUAL.

### CLASS 35—ADVERTISING AND BUSINESS

FOR RESTAURANT FRANCHISING, NAMELY, OFFERING BUSINESS MANAGEMENT ASSISTANCE IN THE ESTABLISHMENT AND/OR OPERATION OF RESTAURANTS (U.S. CLS. 100, 101 AND 102).

FIRST USE 2-16-2010; IN COMMERCE 3-26-2010.

### CLASS 43—HOTEL AND RESTAURANT SERVICES

FOR CAFE AND RESTAURANT SERVICES (U.S. CLS. 100 AND 101).

FIRST USE 2-16-2010; IN COMMERCE 3-26-2010.

RENEE MCCRAY, EXAMINING ATTORNEY

SN 85-024,230. DI PARDO FOODS INC., CALEDON, ONTARIO, CANADA, FILED 4-27-2010.

## LOU & NICKY'S

THE MARK CONSISTS OF STANDARD CHARACTERS WITHOUT CLAIM TO ANY PARTICULAR FONT, STYLE, SIZE, OR COLOR.

OWNER OF CANADA REG. NO. TMA788653, DATED 1-26-2011, EXPIRES 1-26-2026.

### CLASS 29—MEATS AND PROCESSED FOODS

FOR FRUIT JUICES FOR COOKING (U.S. CL. 46).

### CLASS 32—LIGHT BEVERAGES

FOR LEMON JUICE AND LIME JUICE FOR USE IN THE PREPARATION OF BEVERAGES (U.S. CLS. 45, 46 AND 48).

### CLASS 35—ADVERTISING AND BUSINESS

FOR DISTRIBUTORSHIP SERVICES IN THE FIELD OF FRUIT JUICES (U.S. CLS. 100, 101 AND 102).

MARC LEIPZIG, EXAMINING ATTORNEY

## MEXCANANEA

THE MARK CONSISTS OF STANDARD CHARACTERS WITHOUT CLAIM TO ANY PARTICULAR FONT, STYLE, SIZE, OR COLOR.

### CLASS 1—CHEMICALS

FOR METAL PLATING CHEMICAL COMPOSITIONS, NAMELY, ELECTROLYTIC ACID CATHODIC COPPER SOLUTIONS (U.S. CLS. 1, 5, 6, 10, 26 AND 46).

### CLASS 6—METAL GOODS

FOR ELECTROWON CATHODIC COPPER ORES AND COPPER ORE CONCENTRATE (U.S. CLS. 2, 12, 13, 14, 23, 25 AND 50).

KATHERINE CHANG, EXAMINING ATTORNEY

SN 85-024,498. YUMMLY, INC., REDWOOD CITY, CA. FILED 4-27-2010.

## YUMMLY

THE MARK CONSISTS OF STANDARD CHARACTERS WITHOUT CLAIM TO ANY PARTICULAR FONT, STYLE, SIZE, OR COLOR.

### CLASS 9—ELECTRICAL AND SCIENTIFIC APPARATUS

FOR COMPUTER SOFTWARE APPLICATION FOR MOBILE PHONES FEATURING RECIPES AND INFORMATION IN THE FIELDS OF FOOD, COOKING, WINE, BEVERAGES, DINING, ENTERTAINING, ALLERGIES, AND NUTRITION (U.S. CLS. 21, 23, 26, 36 AND 38).

### CLASS 35—ADVERTISING AND BUSINESS

FOR ONLINE RETAIL STORE SERVICES FEATURING FOODS, SPICES, COOKING EQUIPMENT, CULINARY PUBLICATIONS, AND ACCESSORIES; ADVERTISING SERVICES (U.S. CLS. 100, 101 AND 102).

**CLASS 41—EDUCATION AND ENTERTAINMENT**

FOR EDUCATIONAL SERVICES, NAMELY, CONDUCTING CLASSES, SEMINARS, CONFERENCES, WORKSHOPS, AND RETREATS IN THE FIELDS OF FOOD, COOKING, WINE, BEVERAGES, DINING, ENTERTAINING, ALLERGIES, NUTRITION, AND WELLNESS AND DISTRIBUTING COURSE AND EDUCATIONAL MATERIALS IN CONNECTION THEREWITH; ONLINE JOURNALS, NAMELY, BLOGS FEATURING INFORMATION IN THE FIELDS OF RECIPES, FOOD, COOKING, WINE, BEVERAGES, DINING, ENTERTAINING, ALLERGIES, AND NUTRITION; ONLINE PUBLICATIONS, NAMELY, NEWSLETTERS AND MAGAZINES FEATURING RECIPES AND INFORMATION IN THE FIELDS OF FOOD, COOKING, WINE, BEVERAGES, DINING, ENTERTAINING, ALLERGIES, AND NUTRITION (U.S. CLS. 100, 101 AND 107).

**CLASS 42—SCIENTIFIC AND COMPUTER SERVICES**

FOR COMPUTER SERVICES, NAMELY, CREATING AN ONLINE COMMUNITY FOR REGISTERED USERS TO PARTICIPATE IN DISCUSSIONS, SHARE FEEDBACK, FORM VIRTUAL COMMUNITIES, AND ENGAGE IN SOCIAL NETWORKING (U.S. CLS. 100 AND 101).

**CLASS 43—HOTEL AND RESTAURANT SERVICES**

FOR PROVIDING ONLINE DATABASES AND WEBSITES WHERE USERS CAN POST RATINGS, REVIEWS, AND RECOMMENDATIONS FEATURING RECIPES, FOODS, COOKING, WINE, BEVERAGES, DINING, FOOD ALLERGIES IN COOKING, AND FOOD FOR ENTERTAINING (U.S. CLS. 100 AND 101).

**CLASS 44—MEDICAL, BEAUTY AND AGRICULTURAL SERVICES**

FOR PROVIDING ONLINE DATABASES AND WEBSITES WHERE USERS CAN POST RATINGS, REVIEWS, AND RECOMMENDATIONS IN THE FIELD OF NUTRITION TIPS AND INFORMATION, ALLERGIES AND WELLNESS (U.S. CLS. 100 AND 101).

VIVIAN MICZNIK FIRST, EXAMINING ATTORNEY

---

SN 85-024,519. YUMMLY, INC., REDWOOD CITY, CA. FILED 4-27-2010.

# FOODFINDER

THE MARK CONSISTS OF STANDARD CHARACTERS WITHOUT CLAIM TO ANY PARTICULAR FONT, STYLE, SIZE, OR COLOR.

**CLASS 9—ELECTRICAL AND SCIENTIFIC APPARATUS**

FOR COMPUTER SOFTWARE APPLICATION FOR MOBILE PHONES FEATURING RECIPES AND INFORMATION IN THE FIELDS OF FOOD, COOKING, WINE, BEVERAGES, DINING, ENTERTAINING, ALLERGIES, AND NUTRITION (U.S. CLS. 21, 23, 26, 36 AND 38).

**CLASS 35—ADVERTISING AND BUSINESS**

FOR ONLINE RETAIL STORE SERVICES FEATURING FOODS, SPICES, COOKING EQUIPMENT, CULINARY PUBLICATIONS, AND ACCESSORIES; ADVERTISING SERVICES (U.S. CLS. 100, 101 AND 102).

**CLASS 41—EDUCATION AND ENTERTAINMENT**

FOR EDUCATIONAL SERVICES, NAMELY, CONDUCTING CLASSES, SEMINARS, CONFERENCES, WORKSHOPS, AND RETREATS IN THE FIELDS OF FOOD, COOKING, WINE, BEVERAGES, DINING, ENTERTAINING, ALLERGIES, NUTRITION, AND WELLNESS AND DISTRIBUTING COURSE AND EDUCATIONAL MATERIALS IN CONNECTION THEREWITH; ONLINE JOURNALS, NAMELY, BLOGS FEATURING INFORMATION IN THE FIELDS OF RECIPES, FOOD, COOKING, WINE, BEVERAGES, DINING, ENTERTAINING, ALLERGIES, AND NUTRITION; ONLINE PUBLICATIONS, NAMELY, NEWSLETTERS AND MAGAZINES FEATURING RECIPES AND INFORMATION IN THE FIELDS OF FOOD, COOKING, WINE, BEVERAGES, DINING, ENTERTAINING, ALLERGIES, AND NUTRITION (U.S. CLS. 100, 101 AND 107).

**CLASS 42—SCIENTIFIC AND COMPUTER SERVICES**

FOR COMPUTER SERVICES, NAMELY, CREATING AN ONLINE COMMUNITY FOR REGISTERED USERS TO PARTICIPATE IN DISCUSSIONS, SHARE FEEDBACK, FORM VIRTUAL COMMUNITIES, AND ENGAGE IN SOCIAL NETWORKING (U.S. CLS. 100 AND 101).

**CLASS 43—HOTEL AND RESTAURANT SERVICES**

FOR PROVIDING ONLINE DATABASES AND WEBSITES WHERE USERS CAN POST RATINGS, REVIEWS, AND RECOMMENDATIONS FEATURING RECIPES, FOODS, COOKING, WINE, BEVERAGES, DINING, FOOD ALLERGIES IN COOKING, AND FOOD FOR ENTERTAINING (U.S. CLS. 100 AND 101).

**CLASS 44—MEDICAL, BEAUTY AND AGRICULTURAL SERVICES**

FOR PROVIDING ONLINE DATABASES AND WEBSITES WHERE USERS CAN POST RATINGS, REVIEWS, AND RECOMMENDATIONS IN THE FIELD OF NUTRITION TIPS AND INFORMATION, ALLERGIES AND WELLNESS (U.S. CLS. 100 AND 101).

VIVIAN MICZNIK FIRST, EXAMINING ATTORNEY

---

SN 85-025,191. CANDID COLOR SYSTEMS, INC., OKLAHOMA CITY, OK. FILED 4-28-2010.

# MOTHER CLICKER

THE MARK CONSISTS OF STANDARD CHARACTERS WITHOUT CLAIM TO ANY PARTICULAR FONT, STYLE, SIZE, OR COLOR.

NO CLAIM IS MADE TO THE EXCLUSIVE RIGHT TO USE "CLICKER", APART FROM THE MARK AS SHOWN.



**CLASS 9—ELECTRICAL AND SCIENTIFIC APPARATUS**

FOR PHOTOGRAPHY EQUIPMENT, NAMELY, REMOTE SHUTTER CLICKERS (U.S. CLS. 21, 23, 26, 36 AND 38).

**CLASS 41—EDUCATION AND ENTERTAINMENT**

FOR PHOTOGRAPHY SERVICES (U.S. CLS. 100, 101 AND 107).  
ELISSA GARBER KON, EXAMINING ATTORNEY

SN 85-025,252. SQLAB GMBH, STRASSLACH, FED REP GERMANY, FILED 4-28-2010.

# Airgo

THE MARK CONSISTS OF STANDARD CHARACTERS WITHOUT CLAIM TO ANY PARTICULAR FONT, STYLE, SIZE, OR COLOR.

OWNER OF ERPN CMNTY TM OFC REG. NO. 006131783, DATED 4-22-2008, EXPIRES 7-16-2017.

**CLASS 12—VEHICLES**

FOR BICYCLES AND ACCESSORIES THEREFOR, NAMELY, BICYCLE SADDLES, HANDLE BARS FOR BICYCLES, HANDLE BAR STEMS, HANDLE BAR ENDS, HANDLE BAR GRIPS; BICYCLE PARTS, NAMELY, FRAMES, AXLES, BRAKE LEVERS, DRIVE CHAINS (U.S. CLS. 19, 21, 23, 31, 35 AND 44).

**CLASS 25—CLOTHING**

FOR CLOTHING, NAMELY, SHIRTS, SHORTS, COMPRESSION SHORTS, SOCKS, JACKETS, SWEAT SHIRTS AND SWEATPANTS; HEADWEAR, NAMELY, HATS AND CAPS; FOOTWEAR, NAMELY, BOOTS, SHOES AND INSOLES (U.S. CLS. 22 AND 39).

LEIGH CAROLINE CASE, EXAMINING ATTORNEY

SN 85-026,647. RICHARD WELLMAN, NEW YORK, NY. FILED 4-29-2010.

# BIO LIGHTS COLOR

THE MARK CONSISTS OF STANDARD CHARACTERS WITHOUT CLAIM TO ANY PARTICULAR FONT, STYLE, SIZE, OR COLOR.

NO CLAIM IS MADE TO THE EXCLUSIVE RIGHT TO USE "COLOR", APART FROM THE MARK AS SHOWN.

**CLASS 41—EDUCATION AND ENTERTAINMENT**

FOR EDUCATION SERVICES, NAMELY, PROVIDING LIVE CLASSES, SEMINARS AND WORKSHOPS AND ON-LINE INSTRUCTION AND TRAINING IN THE FIELD OF HAIR COLORING AND HAIRDRESSING (U.S. CLS. 100, 101 AND 107).

**CLASS 44—MEDICAL, BEAUTY AND AGRICULTURAL SERVICES**

FOR HAIR SALON SERVICES; HAIRDRESSING SERVICES; HAIR COLORING SERVICES (U.S. CLS. 100 AND 101).

LOURDES AYALA, EXAMINING ATTORNEY

SN 85-026,820. NICHOLAS TAYLOR SHARP, CAVE CREEK, AZ. FILED 4-29-2010.

# INK ARMY

THE MARK CONSISTS OF STANDARD CHARACTERS WITHOUT CLAIM TO ANY PARTICULAR FONT, STYLE, SIZE, OR COLOR.

NO CLAIM IS MADE TO THE EXCLUSIVE RIGHT TO USE "INK" IN INTERNATIONAL CLASSES 16 AND 41, APART FROM THE MARK AS SHOWN.

**CLASS 16—PAPER GOODS AND PRINTED MATTER**

FOR ARTWORK OR GRAPHICS ON PRINTS, POSTERS, PAPER BANNERS, PHOTOGRAPHS, PRINTED PAPER SIGNS, GREETING CARDS, CALENDARS, INK STAMPS, STATIONERY, COLORING BOOKS, BUMPER STICKERS, AND PENS (U.S. CLS. 2, 5, 22, 23, 29, 37, 38 AND 50).

**CLASS 25—CLOTHING**

FOR CLOTHING ITEMS, NAMELY, T-SHIRTS, PANTS, HATS, SOCKS, UNDERWEAR, BELTS, BANDANAS, JACKETS, COATS, GLOVES, SCARVES, AND FOOTWEAR (U.S. CLS. 22 AND 39).

**CLASS 41—EDUCATION AND ENTERTAINMENT**

FOR ENTERTAINMENT SERVICES, NAMELY, PROVIDING A WEBSITE FEATURING AN ONLINE INTERACTIVE DATABASE OF PHOTOS AND VIDEOS IN THE FIELD OF TATTOO ARTWORK, PROVIDING A WEBSITE WHERE USERS CAN POST RATINGS AND REVIEWS OF TATTOO ARTWORK FOR ENTERTAINMENT PURPOSES, AND PROVIDING ENTERTAINMENT INFORMATION, NEWS AND COMMENTARY IN THE FIELD OF TATTOO ARTWORK (U.S. CLS. 100, 101 AND 107).

FIRST USE 4-2-2010; IN COMMERCE 4-2-2010.

ANDREW LEASER, EXAMINING ATTORNEY

SN 85-027,313. VERTEX DATA SCIENCE LTD., PRESCOT, UNITED KINGDOM, FILED 4-30-2010.

# VERTEX OUTPERFORM

THE MARK CONSISTS OF STANDARD CHARACTERS WITHOUT CLAIM TO ANY PARTICULAR FONT, STYLE, SIZE, OR COLOR.

PRIORITY CLAIMED UNDER SEC. 44(D) ON UNITED KINGDOM APPLICATION NO. 2535167, FILED 12-23-2009, REG. NO. 2535167, DATED 4-23-2010, EXPIRES 12-23-2019.  
OWNER OF U.S. REG. NO. 3,412,593.

#### **CLASS 35—ADVERTISING AND BUSINESS**

FOR CUSTOMER RELATIONSHIP MANAGEMENT SERVICES, NAMELY, OPERATING AND MANAGING CUSTOMER SERVICE TELEPHONE CALL CENTERS AND COMPUTERIZED CUSTOMER SERVICE CONTACT CENTERS FOR OTHERS (U.S. CLS. 100, 101 AND 102).

#### **CLASS 41—EDUCATION AND ENTERTAINMENT**

FOR EDUCATION AND TRAINING SERVICES IN THE FIELD OF CUSTOMER SERVICE; COACHING SERVICES IN THE FIELD OF CUSTOMER SERVICE (U.S. CLS. 100, 101 AND 107).

ELISSA GARBER KON, EXAMINING ATTORNEY

---

SN 85-027,355. ARTISTE FLAVOR/ESSENCE, INC., WALDWICK, NJ. FILED 4-30-2010.

# ARTISTE

THE MARK CONSISTS OF STANDARD CHARACTERS WITHOUT CLAIM TO ANY PARTICULAR FONT, STYLE, SIZE, OR COLOR.

#### **CLASS 1—CHEMICALS**

FOR FRAGRANCES FOR USE IN MANUFACTURING COSMETICS, SHAMPOOS, BODY WASHES, SOAPS, PERFUMES, DISHWASHING AND LAUNDRY SOAPS, AND CANDLES (U.S. CLS. 1, 5, 6, 10, 26 AND 46).

#### **CLASS 30—STAPLE FOODS**

FOR FLAVORINGS (U.S. CL. 46).  
TRACY CROSS, EXAMINING ATTORNEY

---

SN 85-027,859. 902149 ALBERTA LTD., EDMONTON, CANADA, FILED 4-30-2010.

# TRUST TORCH

THE MARK CONSISTS OF STANDARD CHARACTERS WITHOUT CLAIM TO ANY PARTICULAR FONT, STYLE, SIZE, OR COLOR.

#### **CLASS 9—ELECTRICAL AND SCIENTIFIC APPARATUS**

FOR COMPUTER SOFTWARE, NAMELY, SOFTWARE DEVELOPMENT TOOLS; COMPUTER SOFTWARE FOR USE AS AN APPLICATION PROGRAMMING INTERFACE, NAMELY, APPLICATION DEVELOPMENT SOFTWARE FOR COMPUTER PROGRAMS USED IN RATING AND RANKING PEOPLE, COMPANIES, ORGANIZATIONS, INTERNET CONTENT, PRODUCTS, SERVICES, ATTRACTIONS, EVENTS, GROUPS, IDEAS AND CHARITABLE CAUSES; APPLICATION PROGRAMMING INTERFACE, NAMELY, COMPUTER PROGRAMMING SOFTWARE FOR USE IN PROCESSING DATA ON ONLINE SOCIAL NETWORKING WEBSITES, CREATING ONLINE SOCIAL NETWORKING SOFTWARE APPLICATIONS, AND SOFTWARE FOR DATA RETRIEVAL, UPLOAD, DOWNLOAD, ACCESS AND MANAGEMENT ON SOCIAL NETWORKING WEBSITES; COMPUTER SOFTWARE FOR ALLOWING UPLOADING, DOWNLOADING, ACCESSING, POSTING, DISPLAYING, TAGGING, BLOGGING, STREAMING, LINKING, SHARING OR OTHERWISE PROVIDING ELECTRONIC MEDIA OR INFORMATION VIA COMPUTER AND COMMUNICATION NETWORKS (U.S. CLS. 21, 23, 26, 36 AND 38).

#### **CLASS 35—ADVERTISING AND BUSINESS**

FOR PROVIDING A WEB SITE FEATURING RATINGS, RANKINGS AND RECOMMENDATIONS FOR THE PRODUCTS AND SERVICES OF OTHERS FOR COMMERCIAL PURPOSES; MARKETING, ADVERTISING AND PROMOTION SERVICES; MARKET RESEARCH AND MARKET RESEARCH INFORMATION SERVICES; PROMOTING THE GOODS, SERVICES AND OFFERINGS OF OTHERS VIA COMPUTER AND COMMUNICATION NETWORKS; FACILITATING THE EXCHANGE AND SALE OF SERVICES AND PRODUCTS OF THIRD PARTIES, NAMELY, PROVIDING A WEB-SITE FOR CONNECTING SELLERS WITH BUYERS; PERMITTING MORE CONFIDENT CHARITABLE GIVING BY VIRTUE OF SURFACING REPUTATION AND CONNECTIONS BETWEEN POTENTIAL DONORS AND CHARITIES, NAMELY, MATCHING INDIVIDUALS WITH LIKEMINDED ORGANIZATIONS WHO PROVIDE CHARITABLE ACTIVITIES THROUGH AN ON-LINE PROFILING SURVEY AND ANALYSIS; FACILITATING PEER-TO-PEER LENDING SERVICES, NAMELY, MATCHING BORROWERS WITH LENDERS IN THE FIELD OF COMMERCIAL LENDING; DATABASE MANAGEMENT FOR OTHERS, NAMELY, MANAGING DATABASES USED IN RATING AND RANKING PEOPLE, COMPANIES, ORGANIZATIONS, INTERNET CONTENT, PRODUCTS, SERVICES, ATTRACTIONS, EVENTS, GROUPS, IDEAS AND CAUSES (U.S. CLS. 100, 101 AND 102).

#### **CLASS 36—INSURANCE AND FINANCIAL**

FOR CREDIT RATING SERVICES; FINANCIAL SERVICES, NAMELY, PROVIDING A VIRTUAL CURRENCY FOR USE BY MEMBERS OF AN ON-LINE COMMUNITY VIA COMPUTER AND COMMUNICATION NETWORKS; AUGMENTING CREDIT-GRANTING DECISIONS OF BANKS AND ONLINE FINANCIAL ENTITIES, NAMELY, EVALUATING THE CREDIT WORTHINESS OF COMPANIES AND PRIVATE INDIVIDUALS (U.S. CLS. 100, 101 AND 102).

**CLASS 41—EDUCATION AND ENTERTAINMENT**

FOR PROVIDING ON-LINE, COMPUTER AND ELECTRONIC DATABASES WHERE USERS CAN POST REVIEWS, RATINGS, RANKINGS AND RECOMMENDATIONS ON EVENTS AND ACTIVITIES IN THE FIELDS OF ENTERTAINMENT AND EDUCATION; PROVIDING INFORMATION ABOUT ONLINE COMPUTER GAMES AND VIDEO GAMES VIA COMPUTER OR COMMUNICATION NETWORKS; PROVIDING A WEBSITE WHERE COMPUTER GAME PLAYERS CAN POST RATINGS OF OTHER PLAYERS, THEIR IN-GAME AVATARS AND THEIR IN-GAME POSSESSIONS AND ATTRIBUTES; PROVIDING RATINGS FOR TELEVISION, MOVIE, MUSIC, VIDEO AND VIDEO GAME CONTENT (U.S. CLS. 100, 101 AND 107).

**CLASS 42—SCIENTIFIC AND COMPUTER SERVICES**

FOR APPLICATION SERVICE PROVIDER, NAMELY, HOSTING, MANAGING, DEVELOPING, AND MAINTAINING APPLICATIONS, SOFTWARE AND WEB SITES, FOR RATING AND RANKING PEOPLE, COMPANIES, ORGANIZATIONS, INTERNET CONTENT, PRODUCTS, SERVICES, ATTRACTIONS, EVENTS, GROUPS, IDEAS AND CAUSES; DATABASE DEVELOPMENT IN THE FIELD OF DATABASES USED IN RATING AND RANKING PEOPLE, COMPANIES, ORGANIZATIONS, INTERNET CONTENT, PRODUCTS, SERVICES, ATTRACTIONS, EVENTS, GROUPS, IDEAS AND CAUSES; APPLICATION SERVICE PROVIDER FEATURING SOFTWARE FOR ALLOWING DATA RETRIEVAL, UPLOAD, ACCESS, STREAMING, POSTING, DISPLAYING, LINKING, SHARING AND OTHERWISE PROVIDING INFORMATION OVER COMMUNICATION NETWORKS; COMPUTER SERVICES, NAMELY, CREATING ON-LINE COMMUNITIES FOR REGISTERED USERS TO PARTICIPATE IN DISCUSSIONS, GET FEEDBACK FROM THEIR PEERS, FORM VIRTUAL COMMUNITIES, AND ENGAGE IN SOCIAL, BUSINESS AND COMMUNITY NETWORKING; SEARCHING AND RETRIEVING INFORMATION, TEXT, ELECTRONIC DOCUMENTS, DATABASES, GRAPHICS AND AUDIO VISUAL INFORMATION AVAILABLE ON COMPUTER NETWORKS FOR OTHERS; PROVIDING TEMPORARY USE OF NON-DOWNLOADABLE SOFTWARE APPLICATIONS TO FACILITATE AND AUGMENT SOCIAL NETWORKING, NAMELY, FOR USE IN PROCESSING DATA ON ONLINE SOCIAL NETWORKING WEBSITES; AND PROVIDING TEMPORARY USE OF NON-DOWNLOADABLE SOFTWARE FOR USE IN CREATING OR ENHANCING A VIRTUAL ONLINE COMMUNITY FOR SOCIAL PURPOSES (U.S. CLS. 100 AND 101).

**CLASS 45—PERSONAL AND LEGAL SERVICES**

FOR ONLINE SOCIAL NETWORKING SERVICES; PROVIDING COMPUTER DATABASES FEATURING INFORMATION IN THE FIELDS OF SOCIAL NETWORKING, PERSONAL RELATIONSHIPS AND DATING; PROVIDING SOCIAL SERVICES, NAMELY, COUNSELING IN THE FIELDS OF PERSONAL DEVELOPMENT AND SELF DEVELOPMENT; PROVIDING AN INTERACTIVE WEB SITE THAT FACILITATES THE VERIFICATION OF A PERSON'S BACKGROUND CREDENTIALS; INVESTIGATION OF ASSETS, CREDIT REPORTS, FISCAL ASSESSMENTS, AND COLLECTION REPORTS FOR SECURITY OR AUTHENTICATION PURPOSES; PROVIDING FOR DISCOVERY ABOUT ATTRIBUTES OF A STRANGER, NAMELY, BACKGROUND INVESTIGATION SERVICES; PRIVATE INVESTIGATION SERVICES FOR USE IN VERIFYING AND DISCOVERING INFORMATION ABOUT PEOPLE, AVATARS, OR PEOPLE BEHIND ALIASES (U.S. CLS. 100 AND 101).

MARTHA FROMM, EXAMINING ATTORNEY

SN 85-028,028. FINDWELL REAL ESTATE, LLC, DBA FINDWELL, SEATTLE, WA. FILED 5-1-2010.



OWNER OF U.S. REG. NO. 3,544,812.

THE COLOR(S) GREEN AND BLACK IS/ARE CLAIMED AS A FEATURE OF THE MARK.

THE MARK CONSISTS OF A GREEN MAGNIFYING GLASS ENCLING A BLACK HOME, FOLLOWED BY THE WORD "FINDWELL". THE LETTERS "FIN" ARE IN LIGHTER BLACK TYPEFACE, FOLLOWED BY THE LETTER "D", WHERE THE BOWL OF THE LETTER IS IN LIGHTER BLACK TYPEFACE AND THE STEM IS IN HEAVIER BLACK TYPEFACE. THIS IS FOLLOWED BY THE LETTERS "WELL" IN HEAVIER BLACK TYPEFACE. THE COLOR WHITE IS BACKGROUND AND IS NOT CLAIMED AS A FEATURE OF THE MARK.

**CLASS 35—ADVERTISING AND BUSINESS**

FOR ADVERTISING OF COMMERCIAL OR RESIDENTIAL REAL ESTATE; MATCHING CONSUMERS WITH REAL ESTATE PROFESSIONALS IN THE FIELD OF REAL ESTATE SERVICES VIA COMPUTER NETWORK; MEMBERSHIP CLUB SERVICES PROVIDING DISCOUNTS TO MEMBERS ON REAL ESTATE COMMISSIONS AND MORTGAGE FEES; NEGOTIATION AND RENEGOTIATION FOR OTHERS OF LEASES AND SUBLEASES AND REAL ESTATE PURCHASE AGREEMENTS; PROVIDING AN INTERACTIVE REAL ESTATE WEBSITE WHICH PROMOTES HOUSING AND APARTMENT PROPERTIES THROUGH OFFERING PROSPECTIVE TENANTS VIDEO WALK THROUGH, PROPERTY DESCRIPTIONS, TEXT, PRICE, LOCATION, MAPS AND OTHER INFORMATION THAT WOULD BE INFLUENTIAL TO A PROSPECTIVE TENANT IN MAKING A RENTAL DECISION; PROVIDING BUSINESS PLANNING AND MARKETING SOLUTIONS FOR REAL ESTATE PROFESSIONALS; PROVIDING REAL ESTATE LEADS FOR PROSPECTIVE PURCHASERS; PROVIDING REAL ESTATE VIDEO TOURS FOR MARKETING PURPOSES; REAL ESTATE ADVERTISING SERVICES; REAL ESTATE MARKETING ANALYSIS; REAL ESTATE MARKETING SERVICES IN THE FIELD OF HOMES AND CONDOMINIUMS; REAL ESTATE MARKETING SERVICES, NAMELY, ON-LINE SERVICES FEATURING THE PROMOTION OF RESIDENTIAL NEW CONSTRUCTION, WHICH ALSO CONTAINS BACK OFFICE SOLUTIONS FOR BUILDERS; REAL ESTATE MARKETING SERVICES, NAMELY, ON-LINE SERVICES FEATURING TOURS OF RESIDENTIAL AND COMMERCIAL REAL ESTATE (U.S. CLS. 100, 101 AND 102).

FIRST USE 3-11-2008; IN COMMERCE 3-11-2008.

**CLASS 36—INSURANCE AND FINANCIAL**

FOR CLASSIFIED REAL ESTATE LISTINGS OF APARTMENT RENTALS AND HOUSING RENTALS; COMMERCIAL AND RESIDENTIAL REAL ESTATE AGENCY SERVICES; FINANCIAL VALUATION OF PERSONAL PROPERTY AND REAL ESTATE; LAND ACQUISITION, NAMELY, REAL ESTATE BROKERAGE; LEASE OF REAL ESTATE; LEASING OF REAL ESTATE; PROVIDING A DATABASE OF INFORMATION ABOUT RESIDENTIAL REAL ESTATE LISTINGS IN DIFFERENT NEIGHBORHOODS AND COMMUNITIES; PROVIDING A DATABASE OF RESIDENTIAL REAL ESTATE LISTINGS WITHIN NEIGHBORHOODS AND COMMUNITIES SPECIFICALLY IDENTIFIED BY USERS; PROVIDING AN INTERNET WEBSITE PORTAL OFFERING INFORMATION IN THE FIELDS OF REAL ESTATE CONCERNING THE PURCHASE AND SALE OF NEW AND RESALE HOMES AND CONDOS; PROVIDING INFORMATION IN THE FIELD OF REAL ESTATE BY MEANS OF LINKING THE WEB SITE TO OTHER WEB SITES FEATURING REAL ESTATE INFORMATION; PROVIDING INFORMATION IN THE FIELD OF

REAL ESTATE VIA THE INTERNET; PROVIDING REAL ESTATE LISTINGS AND REAL ESTATE INFORMATION VIA THE INTERNET; PROVIDING REAL ESTATE LISTINGS VIA THE INTERNET; REAL ESTATE ACQUISITION SERVICES; REAL ESTATE AGENCIES; REAL ESTATE BROKERAGE; REAL ESTATE CONSULTANCY; REAL ESTATE CONSULTATION; REAL ESTATE LISTING; REAL ESTATE LISTING SERVICES FOR HOUSING RENTALS AND APARTMENT RENTALS; REAL ESTATE PROCUREMENT FOR OTHERS; REAL ESTATE RENTAL SERVICES, NAMELY, RENTAL OF RESIDENTIAL HOUSING; REAL ESTATE SERVICE, NAMELY, RENTAL PROPERTY MANAGEMENT; REAL ESTATE SERVICES, NAMELY, PROVIDING ONLINE QUESTIONS TO HELP USERS DETERMINE THE BEST NEIGHBORHOODS AND COMMUNITIES SUITED TO THEIR INDIVIDUAL NEEDS AND PREFERENCES (U.S. CLS. 100, 101 AND 102).

FIRST USE 3-11-2008; IN COMMERCE 3-11-2008.  
KATHLEEN LORENZO, EXAMINING ATTORNEY

SN 85-028,437. NORTH AMERICAN RESCUE, LLC, GREER, SC. FILED 5-3-2010.

## 3X STANDARD

THE MARK CONSISTS OF STANDARD CHARACTERS WITHOUT CLAIM TO ANY PARTICULAR FONT, STYLE, SIZE, OR COLOR.

OWNER OF U.S. REG. NO. 2,931,644.

NO CLAIM IS MADE TO THE EXCLUSIVE RIGHT TO USE "STANDARD", APART FROM THE MARK AS SHOWN.

### CLASS 5—PHARMACEUTICALS

FOR FIRST AID KITS (U.S. CLS. 6, 18, 44, 46, 51 AND 52).

FIRST USE 8-15-2006; IN COMMERCE 8-15-2006.

### CLASS 10—MEDICAL APPARATUS

FOR PATIENT LITTERS IN THE NATURE OF STRETCHERS (U.S. CLS. 26, 39 AND 44).

FIRST USE 8-15-2006; IN COMMERCE 8-15-2006.

CHRISTINE COOPER, EXAMINING ATTORNEY

SN 85-028,553. HOSLEY INTERNATIONAL TRADING CORPORATION, LYNWOOD, IL. FILED 5-3-2010.

## NATURE'S BOUNTY

THE MARK CONSISTS OF STANDARD CHARACTERS WITHOUT CLAIM TO ANY PARTICULAR FONT, STYLE, SIZE, OR COLOR.

### CLASS 3—COSMETICS AND CLEANING PREPARATIONS

FOR POTPOURRI AND FRAGRANCES (U.S. CLS. 1, 4, 6, 50, 51 AND 52).

### CLASS 31—NATURAL AGRICULTURAL PRODUCTS

FOR DRIED FLOWERS, DRIED FLORAL ARRANGEMENTS, DRIED PLANTS (U.S. CLS. 1 AND 46).  
HELENE LIWINSKI, EXAMINING ATTORNEY

SN 85-030,631. ARPAD NAGY, PLEASANTON, CA. FILED 5-5-2010.

## Izonil

THE MARK CONSISTS OF STANDARD CHARACTERS WITHOUT CLAIM TO ANY PARTICULAR FONT, STYLE, SIZE, OR COLOR.

### CLASS 1—CHEMICALS

FOR CHEMICAL ADDITIVES FOR OILS; OIL RECLAMATION FLUID FOR THE SEPARATION OF CRUDE OIL FROM SOIL AND WATER; WATERPROOFING CHEMICAL COMPOSITIONS; WATERPROOFING CHEMICAL COMPOSITIONS FOR ARTICLES OF MASONRY, WOOD AND OTHER BUILDING AND/OR CONSTRUCTION SURFACES (U.S. CLS. 1, 5, 6, 10, 26 AND 46).

### CLASS 17—RUBBER GOODS

FOR OIL ABSORBENT PADS AND PILLOWS FOR CONTAINING OIL SPILLS; WATERPROOF SEALANTS (U.S. CLS. 1, 5, 12, 13, 35 AND 50).

JIM RINGLE, EXAMINING ATTORNEY

SN 85-030,766. JOHNSON & JOHNSON, NEW BRUNSWICK, NJ. FILED 5-5-2010.



THE COLOR(S) RED, ORANGE, YELLOW, GREEN IS/ ARE CLAIMED AS A FEATURE OF THE MARK.

THE MARK CONSISTS OF FLOWER DESIGN IN THE COLORS RED, ORANGE, YELLOW, GREEN.

### CLASS 3—COSMETICS AND CLEANING PREPARATIONS

FOR NON-MEDICATED SKIN CARE PREPARATIONS; SKIN AND FACIAL LOTIONS; FACIAL CLEANSER; SKIN CLEANSING CREAMS AND LOTIONS; NON-MEDICATED SUN CARE PREPARATIONS (U.S. CLS. 1, 4, 6, 50, 51 AND 52).

**CLASS 5—PHARMACEUTICALS**

FOR MEDICATED SKIN CARE PREPARATIONS; MEDICATED SKIN LOTIONS, MEDICATED SKIN CLEANSERS, AND MEDICATED FACIAL CLEANSERS FOR THE TREATMENT OF ECZEMA; MEDICATED SUN CARE PREPARATIONS (U.S. CLS. 6, 18, 44, 46, 51 AND 52).

TRACY CROSS, EXAMINING ATTORNEY

SN 85-032,740. INTERNATIONAL DATA GROUP, INC., FRAMINGHAM, MA. FILED 5-7-2010.

NETWORK WORLD TECH  
CONNECTIONS RESEARCH PANEL

SN 85-031,050. EVOLUTION MEDIA LTD., NEW TERRITORIES, HONG KONG, FILED 5-5-2010.

# evosound

**CLASS 9—ELECTRICAL AND SCIENTIFIC APPARATUS**

FOR PRE-RECORDED MUSIC COMPACT DISCS; PRE-RECORDED DIGITAL VERSATILE DISCS FEATURING MUSIC VIDEOS, PRE-RECORDED OPTICAL DISCS FEATURING MUSIC VIDEOS, DIGITAL MUSIC DOWNLOADABLE FROM THE INTERNET, DIGITAL MUSIC VIDEOS DOWNLOADABLE FROM THE INTERNET (U.S. CLS. 21, 23, 26, 36 AND 38).

FIRST USE 2-1-2005; IN COMMERCE 3-1-2009.

**CLASS 38—COMMUNICATION**

FOR STREAMING OF MUSIC AND MUSIC VIDEOS ON THE INTERNET (U.S. CLS. 100, 101 AND 104).

FIRST USE 2-1-2005; IN COMMERCE 3-1-2009.  
LINDA E. BLOHM, EXAMINING ATTORNEY

THE MARK CONSISTS OF STANDARD CHARACTERS WITHOUT CLAIM TO ANY PARTICULAR FONT, STYLE, SIZE, OR COLOR.

OWNER OF U.S. REG. NOS. 1,401,169, 2,658,857 AND 2,919,026.

NO CLAIM IS MADE TO THE EXCLUSIVE RIGHT TO USE "NETWORK" AND "TECH CONNECTIONS RESEARCH PANEL", APART FROM THE MARK AS SHOWN.

**CLASS 38—COMMUNICATION**

FOR PROVIDING INFORMATION ONLINE IN THE FORM OF SURVEY DATA AND WHITE PAPERS IN THE FIELDS OF COMMUNICATIONS (U.S. CLS. 100, 101 AND 104).

**CLASS 42—SCIENTIFIC AND COMPUTER SERVICES**

FOR PROVIDING INFORMATION ONLINE IN THE FORM OF SURVEY DATA AND WHITE PAPERS IN THE FIELDS OF COMPUTERS, COMPUTER SOFTWARE, AND INFORMATION TECHNOLOGY (U.S. CLS. 100 AND 101).

JULIE WATSON, EXAMINING ATTORNEY

SN 85-031,121. AMANDA BLU & CO., L.L.C., PRAIRIE VILLAGE, KS. FILED 5-5-2010.

# J MICHELLE

THE MARK CONSISTS OF STANDARD CHARACTERS WITHOUT CLAIM TO ANY PARTICULAR FONT, STYLE, SIZE, OR COLOR.

THE NAME(S), PORTRAIT(S), AND/OR SIGNATURE(S) SHOWN IN THE MARK IDENTIFIES "J MICHELLE", WHOSE CONSENT(S) TO REGISTER IS MADE OF RECORD.

**CLASS 14—JEWELRY**

FOR JEWELRY, NAMELY, BRACELETS, NECKLACES, PENDANTS, EARRINGS, AND RINGS; JEWELRY AND PARTS THEREOF, NAMELY, CERAMIC BEADS, GLASS BEADS, CRYSTAL BEADS, BEADS MADE OF PRECIOUS METALS, BEADS MADE OF NATURAL STONES, AND BEADS MADE OF METAL ALLOYS; PEARL JEWELRY; BEADED JEWELRY (U.S. CLS. 2, 27, 28 AND 50).

**CLASS 18—LEATHER GOODS**

FOR HANDBAGS, PURSES, WALLETS AND COIN PURSES (U.S. CLS. 1, 2, 3, 22 AND 41).

**CLASS 25—CLOTHING**

FOR FOOTWEAR (U.S. CLS. 22 AND 39).  
AISHA CLARKE, EXAMINING ATTORNEY

SN 85-032,926. FRITO-LAY NORTH AMERICA, INC., PLANO, TX. FILED 5-7-2010.



OWNER OF U.S. REG. NOS. 2,856,571, 3,518,301 AND OTHERS.

NO CLAIM IS MADE TO THE EXCLUSIVE RIGHT TO USE "MUNCHIES", APART FROM THE MARK AS SHOWN.

THE MARK CONSISTS OF THE WORD "MUNCHIES" IN STYLIZED FORM.

SEC. 2(F).

**CLASS 29—MEATS AND PROCESSED FOODS**

FOR PROCESSED NUTS (U.S. CL. 46).

**CLASS 30—STAPLE FOODS**

FOR CRACKERS (U.S. CL. 46).  
WON TEAK OH, EXAMINING ATTORNEY

SN 85-033,240. HILLERICH & BRADSBY CO., LOUISVILLE, KY. FILED 5-7-2010.

## REAL MEN SWING PINK

THE MARK CONSISTS OF STANDARD CHARACTERS WITHOUT CLAIM TO ANY PARTICULAR FONT, STYLE, SIZE, OR COLOR.

### CLASS 35—ADVERTISING AND BUSINESS

FOR PROMOTING PUBLIC AWARENESS OF BREAST CANCER (U.S. CLS. 100, 101 AND 102).

### CLASS 36—INSURANCE AND FINANCIAL

FOR CHARITABLE FUNDRAISING SERVICES BY MEANS OF SELLING PINK BASEBALL BATS TO RAISE FUNDS FOR BREAST CANCER RESEARCH; CHARITABLE FUNDRAISING SERVICES BY MEANS OF PROVIDING PINK BASEBALL BATS TO OTHERS FOR FUTURE SALE TO RAISE FUNDS FOR BREAST CANCER RESEARCH (U.S. CLS. 100, 101 AND 102).

TRICIA SONNEBORN, EXAMINING ATTORNEY

SN 85-033,370. BLACK RAPID, INC., SEATTLE, WA. FILED 5-7-2010.

## BLACKRAPID

THE MARK CONSISTS OF STANDARD CHARACTERS WITHOUT CLAIM TO ANY PARTICULAR FONT, STYLE, SIZE, OR COLOR.

### CLASS 6—METAL GOODS

FOR METAL CAMERA STRAP HARDWARE, NAMELY, ADJUSTERS, CONNECTORS, FASTENERS, HOOKS, SLIDERS, KEEPERS, AND SWIVELS; METAL BINOCULAR STRAP HARDWARE, NAMELY, ADJUSTERS, CONNECTORS, FASTENERS, HOOKS, SLIDERS, KEEPERS, AND SWIVELS; METAL SPOTTING SCOPE STRAP HARDWARE, NAMELY, ADJUSTERS, CONNECTORS, FASTENERS, HOOKS, SLIDERS, KEEPERS, AND SWIVELS (U.S. CLS. 2, 12, 13, 14, 23, 25 AND 50).

### CLASS 9—ELECTRICAL AND SCIENTIFIC APPARATUS

FOR CAMERA STRAPS AND CONNECTING HARDWARE SOLD AS A UNIT THEREWITH; BINOCULAR STRAPS AND CONNECTING HARDWARE SOLD AS A UNIT THEREWITH; SPOTTING SCOPE STRAPS AND CONNECTING HARDWARE SOLD AS A UNIT THEREWITH; CAMERA STRAP POCKETS; CAMERA STRAP STAYS; CAMERA LENS BAGS; CAMERA BAGS; AUXILIARY CAMERA EQUIPMENT, NAMELY, CAMERA MOUNTING PLATES, TRIPOD MOUNTING PLATES, TRIPOD HEADS, TRIPODS, MONOPOD MOUNTING PLATES, MONOPOD HEADS, AND MONOPODS; AUXILIARY CAMERA EQUIPMENT BAGS (U.S. CLS. 21, 23, 26, 36 AND 38).

### CLASS 20—FURNITURE AND ARTICLES NOT OTHERWISE CLASSIFIED

FOR NON-METAL CAMERA STRAP HARDWARE, NAMELY, ADJUSTERS, CONNECTORS, FASTENERS, HOOKS, SLIDERS, KEEPERS, AND SWIVELS; NON-METAL BINOCULAR STRAP HARDWARE, NAMELY, ADJUSTERS, CONNECTORS, FASTENERS, HOOKS, SLIDERS, KEEPERS, AND SWIVELS; NON-METAL SPOTTING SCOPE STRAP HARDWARE, NAMELY, ADJUSTERS, CONNECTORS, FASTENERS, HOOKS, SLIDERS, KEEPERS, AND SWIVELS (U.S. CLS. 2, 13, 22, 25, 32 AND 50).

RON FAIRBANKS, EXAMINING ATTORNEY

SN 85-035,365. TRANSITIONS OPTICAL, INC., PINELLAS PARK, FL. FILED 5-11-2010.

## LIVE A LIFE LESS SQUINTY

THE MARK CONSISTS OF STANDARD CHARACTERS WITHOUT CLAIM TO ANY PARTICULAR FONT, STYLE, SIZE, OR COLOR.

### CLASS 9—ELECTRICAL AND SCIENTIFIC APPARATUS

FOR OPTICAL LENSES; OPHTHALMIC LENSES, PHOTOCROMIC LENSES, OCULAR LENSES, LENSES FOR EYEWEAR; SPECTACLE LENS BLANKS; SUNGLASSES (U.S. CLS. 21, 23, 26, 36 AND 38).

### CLASS 41—EDUCATION AND ENTERTAINMENT

FOR EDUCATIONAL SERVICES, NAMELY, PROVIDING A WEBSITE FEATURING ONLINE PUBLICATIONS, NAMELY, TIP SHEETS AND FACT SHEETS, IN THE FIELD OF EYEGLASSES AND EYEGLASS LENSES (U.S. CLS. 100, 101 AND 107).

DARRYL SPRUILL, EXAMINING ATTORNEY

SN 85-036,051. FLIGHT CENTRE LIMITED, BRISBANE, QUEENSLAND, AUSTRALIA, FILED 5-12-2010.

**discountcruises.com**  
the world's cruise experts

NO CLAIM IS MADE TO THE EXCLUSIVE RIGHT TO USE "DISCOUNT CRUISES.COM", APART FROM THE MARK AS SHOWN.

THE MARK CONSISTS OF THE WORDS "DISCOUNT-CRUISES.COM THE WORLD'S CRUISE EXPERTS" WITH THE WORDS "THE WORLD'S CRUISE EXPERTS" POSITIONED UNDERNEATH THE WORD "DISCOUNT" AND A STYLIZED WAVE DESIGN POSITIONED UNDER THE WORD "CRUISES.COM".

**CLASS 39—TRANSPORTATION AND STORAGE**

FOR TRAVEL SERVICES BEING SERVICES OFFERED BY TRAVEL AGENTS, NAMELY, PASSENGER TRANSPORT SERVICES; AIR TRAVEL SERVICES, NAMELY, ARRANGING AIR TRANSPORTATION; CAR HIRE SERVICES, NAMELY, ARRANGING CAR TRANSPORT AND RENTAL OF CARS; ROAD TRANSPORT SERVICES, NAMELY, ARRANGING BUS TRANSPORT AND BUS CHARTERING; RAILWAY TRANSPORT SERVICES; SEA TRANSPORT SERVICES, NAMELY, ARRANGING OF BOAT CRUISES, ORGANISING CRUISES, BOAT CHARTERING, PASSENGER SHIP TRANSPORT, FERRY-BOAT TRANSPORT AND RENTAL OF BOATS; TRAVEL AGENCY SERVICES, NAMELY, BOOKING AND RESERVATION OF TRAVEL SERVICES FOR TRANSPORTATION; TRAVEL TICKET RESERVATION SERVICES; TOURIST AGENCY SERVICES, NAMELY, PROVIDING TRAVEL AND TOUR INFORMATION; ORGANIZING SIGHTSEEING TOUR AND CRUISE ARRANGING SERVICES; ARRANGING TRAVEL, CAR RENTAL, TOURS AND CRUISES FOR PACKAGE HOLIDAYS; AIR TRANSPORT SERVICES; TRANSPORT AND DELIVERY OF GOODS; TRAVEL AND TOURIST AGENCY SERVICES, NAMELY, ONLINE SERVICES OF SEARCHING FOR, RESERVING AND BOOKING TRAVEL; TRAVEL AND TOUR INFORMATION SERVICES (U.S. CLS. 100 AND 105).

**CLASS 43—HOTEL AND RESTAURANT SERVICES**

FOR TRAVEL AND TOURIST AGENCY SERVICES, NAMELY, ONLINE SERVICES OF SEARCHING FOR, RESERVING AND BOOKING ACCOMMODATION FOR TEMPORARY LODGING; TRAVEL AGENCY SERVICES, NAMELY, ARRANGING TEMPORARY ACCOMMODATION FOR PACKAGE HOLIDAYS; PROVIDING TRAVEL LODGING INFORMATION SERVICES AND TRAVEL LODGING BOOKING AGENCY SERVICES FOR TRAVELLERS (U.S. CLS. 100 AND 101).

CHRISTINA SOBRAL, EXAMINING ATTORNEY

**CLASS 39—TRANSPORTATION AND STORAGE**

FOR TRAVEL SERVICES BEING SERVICES OFFERED BY TRAVEL AGENTS, NAMELY, PASSENGER TRANSPORT SERVICES; AIR TRAVEL SERVICES, NAMELY, ARRANGING AIR TRANSPORTATION; CAR HIRE SERVICES, NAMELY, ARRANGING CAR TRANSPORT AND RENTAL OF CARS; ROAD TRANSPORT SERVICES, NAMELY, ARRANGING BUS TRANSPORT AND BUS CHARTERING; RAILWAY TRANSPORT SERVICES; SEA TRANSPORT SERVICES, NAMELY, ARRANGING OF BOAT CRUISES, ORGANISING CRUISES, BOAT CHARTERING, PASSENGER SHIP TRANSPORT, FERRY-BOAT TRANSPORT AND RENTAL OF BOATS; TRAVEL AGENCY SERVICES, NAMELY, BOOKING AND RESERVATION OF TRAVEL SERVICES FOR TRANSPORTATION; TRAVEL TICKET RESERVATION SERVICES; TOURIST AGENCY SERVICES, NAMELY, PROVIDING TRAVEL AND TOUR INFORMATION; ORGANIZING SIGHTSEEING TOUR AND CRUISE ARRANGING SERVICES; ARRANGING TRAVEL, CAR RENTAL, TOURS AND CRUISES FOR PACKAGE HOLIDAYS; AIR TRANSPORT SERVICES; TRANSPORT AND DELIVERY OF GOODS; TRAVEL AND TOURIST AGENCY SERVICES, NAMELY, ONLINE SERVICES OF SEARCHING FOR, RESERVING AND BOOKING TRAVEL; TRAVEL AND TOUR INFORMATION SERVICES (U.S. CLS. 100 AND 105).

**CLASS 43—HOTEL AND RESTAURANT SERVICES**

FOR TRAVEL AND TOURIST AGENCY SERVICES, NAMELY, ONLINE SERVICES OF SEARCHING FOR, RESERVING AND BOOKING ACCOMMODATION FOR TEMPORARY LODGING; TRAVEL AGENCY SERVICES, NAMELY, ARRANGING TEMPORARY ACCOMMODATION FOR PACKAGE HOLIDAYS; PROVIDING TRAVEL LODGING INFORMATION SERVICES AND TRAVEL LODGING BOOKING AGENCY SERVICES FOR TRAVELLERS (U.S. CLS. 100 AND 101).

CHRISTINA SOBRAL, EXAMINING ATTORNEY

SN 85-036,053, FLIGHT CENTRE LIMITED, BRISBANE, QUEENSLAND, AUSTRALIA, FILED 5-12-2010.

**FLIGHT CENTER**.com  
the world's airfare experts

OWNER OF U.S. REG. NOS. 3,242,588 AND 3,382,244.  
NO CLAIM IS MADE TO THE EXCLUSIVE RIGHT TO USE "FLIGHT CENTER.COM", APART FROM THE MARK AS SHOWN.

THE MARK CONSISTS OF THE WORDS "FLIGHT CENTER.COM THE WORLD'S AIRFARE EXPERTS" WITH THE TERM ".COM" POSITIONED VERTICALLY TO THE RIGHT OF THE WORD "CENTER" AND THE WORDS "THE WORLD'S AIRFARE EXPERTS" RIGHT JUSTIFIED AND POSITIONED UNDERNEATH THE WORDS "FLIGHT CENTER.COM".

SN 85-036,550, RODIAL LIMITED, LONDON, UNITED KINGDOM, FILED 5-12-2010.

**GLAMOLASH**

THE MARK CONSISTS OF STANDARD CHARACTERS WITHOUT CLAIM TO ANY PARTICULAR FONT, STYLE, SIZE, OR COLOR.

PRIORITY CLAIMED UNDER SEC. 44(D) ON UNITED KINGDOM APPLICATION NO. 2531640, FILED 11-12-2009, REG. NO. 2531640, DATED 11-12-2009, EXPIRES 11-12-2019.

**CLASS 3—COSMETICS AND CLEANING PREPARATIONS**

FOR COSMETICS AND NON-MEDICATED TOILETRIES FOR USE ON AND AROUND THE EYES; MASCARA; EYE MAKE-UP (U.S. CLS. 1, 4, 6, 50, 51 AND 52).

**CLASS 5—PHARMACEUTICALS**

FOR POWDERED NUTRITIONAL SUPPLEMENT DRINK MIX FOR ENHANCING THE GROWTH OF EYELASHES (U.S. CLS. 6, 18, 44, 46, 51 AND 52).

SUSAN STIGLITZ, EXAMINING ATTORNEY

SN 85-036,923. TABLE TENNIS NATION, LLC, CHAPPAQUA, NY. FILED 5-12-2010.

## TABLE TENNIS NATION

THE MARK CONSISTS OF STANDARD CHARACTERS WITHOUT CLAIM TO ANY PARTICULAR FONT, STYLE, SIZE, OR COLOR.

NO CLAIM IS MADE TO THE EXCLUSIVE RIGHT TO USE "TABLE TENNIS", APART FROM THE MARK AS SHOWN.

### CLASS 25—CLOTHING

FOR CLOTHING, NAMELY, T-SHIRTS, LONG SLEEVE SHIRTS, DRESS SHIRTS, BLOUSES, SKIRTS, SHORTS, PANTS, WRISTBANDS, GLOVES, HEADBANDS, SWEATPANTS, SNEAKERS, SHOES, JACKETS, PULLOVERS, UNDERWEAR, BATHING SUITS, BRAS, SLEEPING MASKS, HATS, CAPS, SOCKS, SHOELACES, JERSEYS, COATS, CAPES, TIGHTS, CAPRIS, TIES, PONCHOS, ROBES, DRESSES, SUITS (U.S. CLS. 22 AND 39).

### CLASS 28—TOYS AND SPORTING GOODS

FOR TABLE TENNIS EQUIPMENT, NAMELY, TABLE TENNIS PADDLES, TABLE TENNIS BALLS, TABLE TENNIS TABLES, TABLE TENNIS TABLE COVERS, TABLE TENNIS PADDLE COVERS, TABLE TENNIS NETS, TABLE TENNIS HANDLES, TABLE TENNIS PADDLE INSERTS, TABLE TENNIS GLOVES, TABLE TENNIS FLOORING AND TABLE TENNIS DRAW SHEETS (U.S. CLS. 22, 23, 38 AND 50).

### CLASS 41—EDUCATION AND ENTERTAINMENT

FOR ENTERTAINMENT SERVICES, NAMELY, PRODUCING AN ONGOING TELEVISION PROGRAM IN THE FIELD OF TABLE TENNIS; ENTERTAINMENT SERVICES IN THE NATURE OF LIVE PERFORMANCES IN THE NATURE OF TABLE TENNIS TOURNAMENTS; ENTERTAINMENT AND INSTRUCTIONAL SERVICES IN THE NATURE OF CLASSES AND WORKSHOPS IN THE FIELD OF TABLE TENNIS; ORGANIZING SPORTING AND RECREATIONAL EVENTS IN THE NATURE OF TABLE TENNIS COMPETITIONS; PRODUCTION OF TELEVISION PROGRAMS, MOVIES AND VIDEOS, ALL FEATURING TABLE TENNIS (U.S. CLS. 100, 101 AND 107).

KAREN SEVERSON, EXAMINING ATTORNEY

SN 85-036,969. TABLE TENNIS NATION, LLC, CHAPPAQUA, NY. FILED 5-12-2010.



THE MARK CONSISTS OF A SILHOUETTE OF A MAN PLAYING TABLE TENNIS, WITH THE SILHOUETTE APPEARING TO REST ON A HORIZONTAL LINE.

### CLASS 25—CLOTHING

FOR CLOTHING, NAMELY, T-SHIRTS, LONG SLEEVE SHIRTS, DRESS SHIRTS, BLOUSES, SKIRTS, SHORTS, PANTS, WRISTBANDS, GLOVES, HEADBANDS, SWEATPANTS, SNEAKERS, SHOES, JACKETS, PULLOVERS, UNDERWEAR, BATHING SUITS, BRAS, SLEEPING MASKS, HATS, CAPS, SOCKS, SHOELACES, JERSEYS, COATS, CAPES, TIGHTS, CAPRIS, TIES, PONCHOS, ROBES, DRESSES (U.S. CLS. 22 AND 39).

### CLASS 28—TOYS AND SPORTING GOODS

FOR TABLE TENNIS EQUIPMENT, NAMELY, TABLE TENNIS PADDLES, TABLE TENNIS BALLS, TABLE TENNIS TABLES, TABLE TENNIS TABLE COVERS, TABLE TENNIS PADDLE COVERS, TABLE TENNIS NETS, TABLE TENNIS HANDLES, TABLE TENNIS PADDLE INSERTS, TABLE TENNIS GLOVES, TABLE TENNIS FLOORING AND TABLE TENNIS DRAW SHEETS (U.S. CLS. 22, 23, 38 AND 50).

### CLASS 41—EDUCATION AND ENTERTAINMENT

FOR ENTERTAINMENT SERVICES, NAMELY, PRODUCING AN ONGOING TELEVISION PROGRAM IN THE FIELD OF TABLE TENNIS; ENTERTAINMENT SERVICES IN THE NATURE OF LIVE PERFORMANCES IN THE NATURE OF TABLE TENNIS TOURNAMENTS; ENTERTAINMENT AND INSTRUCTIONAL SERVICES IN THE NATURE OF CLASSES AND WORKSHOPS IN THE FIELD OF TABLE TENNIS; ORGANIZING SPORTING AND RECREATIONAL EVENTS IN THE NATURE OF TABLE TENNIS COMPETITIONS; PRODUCTION OF TELEVISION PROGRAMS, MOVIES AND VIDEOS, ALL FEATURING TABLE TENNIS (U.S. CLS. 100, 101 AND 107).

KAREN SEVERSON, EXAMINING ATTORNEY

SN 85-036,980. TABLE TENNIS NATION, LLC, CHAPPAQUA, NY. FILED 5-12-2010.

## THE BRAWL

THE MARK CONSISTS OF STANDARD CHARACTERS WITHOUT CLAIM TO ANY PARTICULAR FONT, STYLE, SIZE, OR COLOR.

### CLASS 16—PAPER GOODS AND PRINTED MATTER

FOR BOOKS AND PRINTED PUBLICATIONS IN THE NATURE OF TABLE TENNIS NARRATIVE BOOKS, TABLE TENNIS INSTRUCTIONAL BOOKS, TABLE TENNIS ARTICLES, TABLE TENNIS PUBLICATIONS, TABLE TENNIS MAGAZINES, PRINTED GUIDES, NAMELY, RULES FOR TABLE TENNIS (U.S. CLS. 2, 5, 22, 23, 29, 37, 38 AND 50).



**CLASS 41—EDUCATION AND ENTERTAINMENT**

FOR ENTERTAINMENT SERVICES, NAMELY, PRODUCING AN ONGOING TELEVISION PROGRAM IN THE FIELD OF TABLE TENNIS; ENTERTAINMENT SERVICES IN THE NATURE OF LIVE PERFORMANCES IN THE NATURE OF TABLE TENNIS TOURNAMENTS; ENTERTAINMENT AND INSTRUCTIONAL SERVICES IN THE NATURE OF CLASSES AND WORKSHOPS IN THE FIELD OF TABLE TENNIS; ORGANIZING SPORTING AND RECREATIONAL EVENTS IN THE NATURE OF TABLE TENNIS COMPETITIONS; PRODUCTION OF TELEVISION PROGRAMS, MOVIES AND VIDEOS, ALL FEATURING TABLE TENNIS (U.S. CLS. 100, 101 AND 107).

KAREN SEVERSON, EXAMINING ATTORNEY

SN 85-038,582. TY LOKE, LLC, NEW YORK, NY. FILED 5-14-2010.

**MODELLAND**

THE MARK CONSISTS OF STANDARD CHARACTERS WITHOUT CLAIM TO ANY PARTICULAR FONT, STYLE, SIZE, OR COLOR.

**CLASS 35—ADVERTISING AND BUSINESS**

FOR PROVIDING A WEB SITE AND AN INTERACTIVE WEB SITE FEATURING INFORMATION IN THE FIELD OF MODELING FOR ADVERTISING OR SALES PROMOTION (U.S. CLS. 100, 101 AND 102).

**CLASS 38—COMMUNICATION**

FOR PROVIDING ON-LINE CHAT ROOMS AND ELECTRONIC BULLETIN BOARDS FOR TRANSMISSION OF MESSAGES AMONG USERS IN THE FIELD OF GENERAL INTEREST; COMPUTER SERVICES, NAMELY, PROVIDING ON-LINE FACILITIES FOR REAL-TIME INTERACTION WITH OTHER COMPUTER USERS CONCERNING TOPICS OF GENERAL INTEREST; STREAMING OF AUDIO, VISUAL AND AUDIO-VISUAL MATERIAL VIA A GLOBAL COMPUTER NETWORK; VIDEO STREAMING SERVICES VIA THE INTERNET, FEATURING INDEPENDENT FILMS AND MOVIES (U.S. CLS. 100, 101 AND 104).

**CLASS 41—EDUCATION AND ENTERTAINMENT**

FOR ENTERTAINMENT IN THE NATURE OF ONGOING TELEVISION AND CABLE TELEVISION PROGRAMS FEATURING SHOWS THAT ARE HALF REALITY AND HALF SCRIPTED; ENTERTAINMENT IN THE NATURE OF ON-GOING TELEVISION AND CABLE TELEVISION PROGRAMS FEATURING REALITY, FICTION, TALENT AND OTHER COMPETITIONS, AND OTHER SUBJECT MATTERS; ENTERTAINMENT, NAMELY, A CONTINUING VARIETY SHOW AND REALITY SHOW BROADCAST OVER TELEVISION, CABLE TELEVISION, SATELLITE, WEBCASTS, RADIO, COMPUTER NETWORKS, VIDEO AND VIDEO MEDIA; PRODUCTION OF DVDS, VIDEO DISCS, VIDEO TAPES, MOTION PICTURE FILMS AND TELEVISION PROGRAMS FEATURING REALITY, FICTION, TALENT AND OTHER COMPETITIONS, AND OTHER SUBJECT MATTERS; TELEVISION AND CABLE TELEVISION SHOW PRODUCTION; MOTION PICTURE FILM PRODUCTION; PRODUCTION OF REALITY-BASED TELEVISION SHOWS, CABLE TELEVISION SHOWS AND MOTION PICTURE FILMS; ENTERTAINMENT IN THE NATURE OF THEATRE PRODUCTIONS; INTERNET SERVICES PROVIDING INFORMATION VIA AN

ELECTRONIC GLOBAL COMPUTER NETWORK IN THE FIELD OF ENTERTAINMENT PARTICULARLY RELATING TO TELEVISION AND MOVIES; PROVIDING NEWS ABOUT BEAUTY AND FASHION, MODELING, LIFESTYLES, THE ARTS, CULTURE, MUSIC, ENTERTAINMENT, TELEVISION AND FILMS, CELEBRITIES, MODELS, ENTERTAINERS, POP CULTURE, AND TALENT AND OTHER COMPETITIONS, AND ENTERTAINMENT AND EDUCATION INFORMATION VIA A GLOBAL COMPUTER NETWORK; PROVIDING INFORMATION FOR AND ACTUAL ENTERTAINMENT VIA AN ELECTRONIC GLOBAL COMPUTER NETWORK IN THE NATURE OF REALITY-BASED AND TALENT COMPETITION PROGRAMS; PRODUCTION OF REALITY-BASED MOTIONAL PICTURE FILMS FOR DISTRIBUTION VIA A GLOBAL COMPUTER NETWORK; PRODUCTION AND PRESENTATION OF MOTION PICTURE FILMS; PRODUCTION AND PRESENTATION OF TELEVISION AND CABLE TELEVISION PROGRAMS; PROVIDING ENTERTAINMENT IN THE NATURE OF AN ONGOING TELEVISION PROGRAM IN THE FIELDS OF REALITY-BASED SITUATIONS MIXED WITH SCRIPTED CONTENT, TALENT AND OTHER COMPETITIONS; PRODUCTION OF ONGOING TELEVISION SHOWS AND INTERACTIVE TELEVISION PROGRAMS IN THE FIELD OF BEAUTY AND FASHION, MODELING, LIFESTYLES, THE ARTS, CULTURE, MUSIC, ENTERTAINMENT, TELEVISION AND FILMS, CELEBRITIES, MODELS, ENTERTAINERS, POP CULTURE, TRUE LIFE STORIES, REALITY SHOWS AND DOCUMENTARIES, TALENT AND OTHER COMPETITIONS, AND FICTION FOR DISTRIBUTION VIA TELEVISION, CABLE, SATELLITE, AUDIO AND VIDEO MEDIA AND ELECTRONIC MEANS; PRODUCTION AND PROVISION OF TELEVISION AND CABLE TELEVISION SHOWS IN THE FIELD OF ENTERTAINMENT VIA COMMUNICATION AND COMPUTER NETWORKS; ENTERTAINMENT IN THE NATURE OF BEAUTY PAGEANTS; ENTERTAINMENT IN THE NATURE OF FASHION SHOWS; ENTERTAINMENT IN THE NATURE OF ONGOING TELEVISION AND CABLE TELEVISION SHOWS AND PROGRAMS FEATURING MODELING AND/OR BEAUTY COMPETITIONS, EVENTS AND EXHIBITIONS; ENTERTAINMENT SERVICES, NAMELY, CONDUCTING CONTESTS AND PARTIES; ENTERTAINMENT IN THE NATURE OF ORGANIZING AND CONDUCTING TALENT, MODELING AND BEAUTY COMPETITIONS; ENTERTAINMENT IN THE NATURE OF BEAUTY PAGEANTS, MODELING CONTESTS, PHOTO CONTESTS AND ONLINE BEAUTY CONTESTS; MUSIC PUBLISHING SERVICES; MUSIC COMPOSITION AND TRANSCRIPTION FOR OTHERS; PUBLICATION OF BOOKS AND MAGAZINES; RECORD PRODUCTION; MUSIC PRODUCTION; AUDIO RECORDING AND PRODUCTION; VIDEOTAPE PRODUCTION; MOTION PICTURE SONG PRODUCTION; RECORDING STUDIOS; ENTERTAINMENT SERVICES, NAMELY, PRODUCING MUSICAL AUDIO AND VIDEO PROGRAMS; DISTRIBUTING MUSICAL AUDIO AND VIDEO PROGRAMS; DISTRIBUTION OF MUSICAL AUDIO AND VIDEO RECORDINGS FOR BROADCAST; ENTERTAINMENT SERVICES, NAMELY, PRESENTING NON-DOWNLOADABLE RING TONES, PRE-RECORDED MUSIC, VIDEO AND GRAPHICS TO MOBILE COMMUNICATIONS DEVICES VIA A GLOBAL COMPUTER NETWORK AND WIRELESS NETWORKS; ON-LINE JOURNALS, NAMELY, BLOGS FEATURING A WIDE VARIETY OF SUBJECT MATTERS; PROVIDING A WEB SITE AND AN INTERACTIVE WEB SITE FEATURING INFORMATION IN THE FIELD OF ENTERTAINMENT, TELEVISION, FILM, MUSIC, DANCE, THE ARTS, TOPICAL NEWS, POP CULTURE, CELEBRITIES, AND LIFESTYLES; PROVIDING A WEB SITE AND AN INTERACTIVE WEB SITE FEATURING INFORMATION IN THE FIELD OF MODELING FOR ENTERTAINMENT PURPOSES (U.S. CLS. 100, 101 AND 107).

**CLASS 44—MEDICAL, BEAUTY AND AGRICULTURAL SERVICES**

FOR PROVIDING A WEB SITE AND AN INTERACTIVE WEB SITE FEATURING INFORMATION IN THE FIELD OF BEAUTY (U.S. CLS. 100 AND 101).

**CLASS 45—PERSONAL AND LEGAL SERVICES**

FOR PROVIDING A WEB SITE AND AN INTERACTIVE WEB SITE FEATURING INFORMATION IN THE FIELD OF FASHION (U.S. CLS. 100 AND 101).  
THEODORE MCBRIDE, EXAMINING ATTORNEY

**CLASS 32—LIGHT BEVERAGES**

FOR PORTABLE SELF-HEATING PACKAGED BEVERAGES, NAMELY, DRINKING WATER (U.S. CLS. 45, 46 AND 48).  
BARBARA BROWN, EXAMINING ATTORNEY

---

SN 85-038,583. TRILLIUM WORLDWIDE GROUP INC., PROVIDENCIALES, B.W.I., TURKS/CAICOS IS., FILED 5-14-2010.

---

SN 85-039,978. GREAT LAKES TRANSPORTATION HOLDING LLC, TAYLOR, MI. FILED 5-17-2010.

**HEATERDRINKS 4 U**

THE MARK CONSISTS OF STANDARD CHARACTERS WITHOUT CLAIM TO ANY PARTICULAR FONT, STYLE, SIZE, OR COLOR.

**CLASS 29—MEATS AND PROCESSED FOODS**

FOR PORTABLE SELF-HEATING PACKAGED BEVERAGES, NAMELY, SOUP AND MILK (U.S. CL. 46).

**CLASS 30—STAPLE FOODS**

FOR PORTABLE SELF-HEATING PACKAGED BEVERAGES, NAMELY, TEA, COFFEE, COCOA AND HOT CHOCOLATE (U.S. CL. 46).

**CLASS 32—LIGHT BEVERAGES**

FOR PORTABLE SELF-HEATING PACKAGED BEVERAGES, NAMELY, DRINKING WATER (U.S. CLS. 45, 46 AND 48).  
BARBARA BROWN, EXAMINING ATTORNEY

---

SN 85-038,651. TRILLIUM WORLDWIDE GROUP INC., PROVIDENCIALES, B.W.I., TURKS/CAICOS IS., FILED 5-14-2010.

**HEATERPAK**

THE MARK CONSISTS OF STANDARD CHARACTERS WITHOUT CLAIM TO ANY PARTICULAR FONT, STYLE, SIZE, OR COLOR.

**CLASS 29—MEATS AND PROCESSED FOODS**

FOR PORTABLE SELF-HEATING PACKAGED BEVERAGES, NAMELY, SOUP AND MILK (U.S. CL. 46).

**CLASS 30—STAPLE FOODS**

FOR PORTABLE SELF-HEATING PACKAGED BEVERAGES, NAMELY, TEA, COFFEE, COCOA AND HOT CHOCOLATE (U.S. CL. 46).

**METRO NATIONWIDE**

THE MARK CONSISTS OF STANDARD CHARACTERS WITHOUT CLAIM TO ANY PARTICULAR FONT, STYLE, SIZE, OR COLOR.

OWNER OF U.S. REG. NOS. 1,908,853, 2,931,458 AND OTHERS.

NO CLAIM IS MADE TO THE EXCLUSIVE RIGHT TO USE "NATIONWIDE", APART FROM THE MARK AS SHOWN.

**CLASS 35—ADVERTISING AND BUSINESS**

FOR TRANSPORTATION MANAGEMENT SERVICES, NAMELY, PLANNING AND COORDINATING TRANSPORTATION OF PEOPLE FOR OTHERS (U.S. CLS. 100, 101 AND 102).

**CLASS 39—TRANSPORTATION AND STORAGE**

FOR CHAUFFEUR SERVICES, NAMELY, PROVIDING CHAUFFEURED AUTOMOBILES, LUXURY AUTOMOBILES AND LIMOUSINES FOR HIRE; LUXURY DOOR-TO-DOOR GROUND TRANSPORTATION OF PASSENGERS FOR BUSINESS OR PERSONAL TRAVEL BY LUXURY AUTOMOBILE, LIMOUSINE, EXECUTIVE VAN, MINI BUS AND MOTOR COACH; AIRPORT PASSENGER GROUND TRANSPORTATION SERVICES; AIRPORT MEET AND GREET SERVICES, NAMELY, MEETING AND GREETING PASSENGERS AND DIRECTING THEM TO A SPECIFIC MEANS OF TRANSPORTATION; PROVIDING GROUND TRANSPORTATION TO CORPORATE CUSTOMERS IN THE NATURE OF PASSENGER SHUTTLES; MOTOR COACH CHARTER SERVICES; TAXI TRANSPORT SERVICE; MEDICALLY-RELATED PARA-TRANSIT GROUND TRANSPORTATION SERVICES (U.S. CLS. 100 AND 105).

SIMON TENG, EXAMINING ATTORNEY

---

SN 85-041,123. PLAYERS2FANS, LLC, FLORAL PARK, NY. FILED 5-18-2010.

**PLAYERS2FANS**

THE MARK CONSISTS OF STANDARD CHARACTERS WITHOUT CLAIM TO ANY PARTICULAR FONT, STYLE, SIZE, OR COLOR.

**CLASS 35—ADVERTISING AND BUSINESS**

FOR PROVIDING ADVERTISING SERVICES TO DISTRIBUTE ADVERTISEMENTS FOR DISPLAY ON INTERNET, NAMELY, IN WEBSITES, SOCIAL CONVERSATIONS OVER THE INTERNET, EMAILS, MICROBLOGS, BLOGS, ELECTRONIC MESSAGES, INSTANT MESSAGES, TEXT MESSAGES, MULTIMEDIA MESSAGES, SOCIAL NETWORKS, STATUS UPDATES, FORUMS, AND ELECTRONIC BULLETIN BOARDS (U.S. CLS. 100, 101 AND 102).

**CLASS 35—ADVERTISING AND BUSINESS**

FOR PROVIDING ADVERTISING SERVICES TO DISTRIBUTE ADVERTISEMENTS FOR DISPLAY ON INTERNET, NAMELY, IN WEBSITES, SOCIAL CONVERSATIONS OVER THE INTERNET, EMAILS, MICROBLOGS, BLOGS, ELECTRONIC MESSAGES, INSTANT MESSAGES, TEXT MESSAGES, MULTIMEDIA MESSAGES, SOCIAL NETWORKS, STATUS UPDATES, FORUMS, AND ELECTRONIC BULLETIN BOARDS (U.S. CLS. 100, 101 AND 102).

**CLASS 38—COMMUNICATION**

FOR ELECTRONIC MESSAGE TRANSMISSION BETWEEN ATHLETES AND THE PUBLIC BY MEANS OF EMAILS, ELECTRONIC MESSAGING, INSTANT MESSAGING, TEXT MESSAGING, MULTIMEDIA MESSAGING, CHAT ROOMS FOR SOCIAL NETWORKING, STATUS UPDATES VIA EMAIL, ELECTRONIC BULLETIN BOARDS, AND FORUMS CONCERNING SPORTS-RELATED AND ATHLETE-RELATED TOPICS (U.S. CLS. 100, 101 AND 104).

**CLASS 38—COMMUNICATION**

FOR ELECTRONIC MESSAGE TRANSMISSION BETWEEN ATHLETES AND THE PUBLIC BY MEANS OF EMAILS, ELECTRONIC MESSAGING, INSTANT MESSAGING, TEXT MESSAGING, MULTIMEDIA MESSAGING, CHAT ROOMS FOR SOCIAL NETWORKING, STATUS UPDATES VIA EMAIL, ELECTRONIC BULLETIN BOARDS, AND FORUMS CONCERNING SPORTS-RELATED AND ATHLETE-RELATED TOPICS (U.S. CLS. 100, 101 AND 104).

**CLASS 41—EDUCATION AND ENTERTAINMENT**

FOR PROVIDING ENTERTAINMENT SERVICES IN THE NATURE OF FANTASY SPORTS LEAGUES AND TOURNAMENTS; ON-LINE JOURNALS, NAMELY, BLOGS FOR ATHLETES AND THE PUBLIC FEATURING SPORTS-RELATED AND ATHLETE-RELATED TOPICS (U.S. CLS. 100, 101 AND 107).

**CLASS 41—EDUCATION AND ENTERTAINMENT**

FOR PROVIDING ENTERTAINMENT SERVICES IN THE NATURE OF FANTASY SPORTS LEAGUES AND TOURNAMENTS; ON-LINE JOURNALS, NAMELY, BLOGS FOR ATHLETES AND THE PUBLIC FEATURING SPORTS-RELATED AND ATHLETE-RELATED TOPICS (U.S. CLS. 100, 101 AND 107).

**CLASS 42—SCIENTIFIC AND COMPUTER SERVICES**

FOR COMPUTER SERVICES, NAMELY, HOSTING AND MAINTAINING ON-LINE, INTERACTIVE WEBSITES FOR OTHERS FOR ELECTRONIC MESSAGING BETWEEN ATHLETES AND THE PUBLIC BY MEANS OF EMAILS, MICROBLOGS, BLOGS, ELECTRONIC MESSAGING, INSTANT MESSAGING, TEXT MESSAGING, MULTIMEDIA MESSAGING, SOCIAL NETWORKS, STATUS UPDATES, FORUMS, AND ELECTRONIC BULLETIN BOARDS (U.S. CLS. 100 AND 101).

**CLASS 42—SCIENTIFIC AND COMPUTER SERVICES**

FOR COMPUTER SERVICES, NAMELY, HOSTING AND MAINTAINING ON-LINE, INTERACTIVE WEBSITES FOR OTHERS FOR ELECTRONIC MESSAGING BETWEEN ATHLETES AND THE PUBLIC BY MEANS OF EMAILS, MICROBLOGS, BLOGS, ELECTRONIC MESSAGING, INSTANT MESSAGING, TEXT MESSAGING, MULTIMEDIA MESSAGING, SOCIAL NETWORKS, STATUS UPDATES, FORUMS, AND ELECTRONIC BULLETIN BOARDS (U.S. CLS. 100 AND 101).

**CLASS 45—PERSONAL AND LEGAL SERVICES**

FOR ON-LINE SOCIAL NETWORKING SERVICES PROVIDED THROUGH A SPORTS COMMUNITY WEBSITE FOR ATHLETES AND THE PUBLIC (U.S. CLS. 100 AND 101).

ALICIA COLLINS, EXAMINING ATTORNEY

**CLASS 45—PERSONAL AND LEGAL SERVICES**

FOR ON-LINE SOCIAL NETWORKING SERVICES PROVIDED THROUGH A SPORTS COMMUNITY WEBSITE FOR ATHLETES AND THE PUBLIC (U.S. CLS. 100 AND 101).

ALICIA COLLINS, EXAMINING ATTORNEY

SN 85-041,153. PLAYERS2FANS, LLC, FLORAL PARK, NY. FILED 5-18-2010.

P2F

THE MARK CONSISTS OF STANDARD CHARACTERS WITHOUT CLAIM TO ANY PARTICULAR FONT, STYLE, SIZE, OR COLOR.

SN 85-042,346. BOARD OF TRUSTEES OF THE UNIVERSITY OF ALABAMA, TUSCALOOSA, AL. FILED 5-19-2010.



THE COLOR(S) CRIMSON RED AND WHITE IS/ARE CLAIMED AS A FEATURE OF THE MARK. THE MARK CONSISTS OF THE TRADE DRESS COM-

PRISING THE COLOR COMBINATION OF CRIMSON RED AND WHITE, THE CRIMSON RED AS APPLIED TO THE OUTER SURFACE OF THE HELMET AND THE WHITE AS A STRIPE RUNNING FROM FRONT TO BACK ALONG THE CENTER OF THE HELMET. THE BROKEN LINES OF THE DRAWING FORM NO PART OF THE MARK, SERVING AS A POSITIONAL REFERENCE ONLY. THE HELMET, INCLUDING THE FACEMASK, AND THE BLACK SHADING REPRESENTING THE INTERIOR OF THE HELMET, FORM NO FEATURE THE MARK.  
SEC. 2(F).

#### **CLASS 9—ELECTRICAL AND SCIENTIFIC APPARATUS**

FOR SPORTS HELMETS (U.S. CLS. 21, 23, 26, 36 AND 38).  
FIRST USE 0-0-1984; IN COMMERCE 0-0-1984.

#### **CLASS 41—EDUCATION AND ENTERTAINMENT**

FOR ENTERTAINMENT AND EDUCATIONAL SERVICES, NAMELY, PROVIDING COURSES OF INSTRUCTION AT THE UNIVERSITY LEVEL; EDUCATIONAL RESEARCH; ARRANGING AND CONDUCTING ATHLETIC COMPETITIONS, EVENTS, TOURNAMENTS, AND EXHIBITIONS (U.S. CLS. 100, 101 AND 107).  
FIRST USE 0-0-1961; IN COMMERCE 0-0-1961.  
HANNO RITTNER, EXAMINING ATTORNEY

#### **CLASS 9—ELECTRICAL AND SCIENTIFIC APPARATUS**

FOR DOWNLOADABLE ELECTRONIC PUBLICATIONS IN THE NATURE OF ARTICLES IN THE FIELD OF INTELLECTUAL PROPERTY; DOWNLOADABLE AUDIO FILES, MULTIMEDIA FILES, TEXT FILES, WRITTEN DOCUMENTS, AND AUDIO MATERIAL FEATURING INFORMATION IN THE FORM OF DOWNLOADABLE EDUCATIONAL/INFORMATIONAL COMMUNICATIONS IN THE FIELD OF INTELLECTUAL PROPERTY (U.S. CLS. 21, 23, 26, 36 AND 38).  
FIRST USE 10-15-2009; IN COMMERCE 10-15-2009.

#### **CLASS 16—PAPER GOODS AND PRINTED MATTER**

FOR PRINTED INSTRUCTIONAL, EDUCATIONAL, AND TEACHING MATERIALS RELATED TO INTELLECTUAL PROPERTY (U.S. CLS. 2, 5, 22, 23, 29, 37, 38 AND 50).  
FIRST USE 7-22-2009; IN COMMERCE 7-22-2009.

SN 85-042,951. AMERICAN INTELLECTUAL PROPERTY LAW ASSOCIATION, INC., ARLINGTON, VA. FILED 5-19-2010.



NO CLAIM IS MADE TO THE EXCLUSIVE RIGHT TO USE "©" AS PART OF THE DESIGN ELEMENT OF THE MARK, APART FROM THE MARK AS SHOWN.

THE MARK CONSISTS OF A STYLIZED TREE WITH A REACHING HAND REPRESENTING THE TRUNK AND BRANCHES, SWIRLS AS LEAVES, AND THE FOLLOWING SYMBOLS AS BLOOMS: TECHNOLOGY SYMBOLS RELATED TO PATENTS INCLUDING A BEAKER CONTAINING A REACTING LIQUID, AN ATOMIC MODEL, A GEAR, A SERIES OF WAVY LINES REPRESENTING A WAVEFORM, 2 LEAVES REPRESENTING BIOTECHNOLOGY AND GREEN TECHNOLOGY, AND A SERIES OF BINARY NUMBERS REPRESENTING COMPUTER LANGUAGE AND SOFTWARE; ARTISTIC SYMBOLS RELATED TO COPYRIGHT INCLUDING A TREBLE CLEF, A BASS CLEF, AND A SECTION OF PHOTOGRAPHIC FILM; AND THE TRADITIONAL CIRCLE R SYMBOL RELATING TO TRADEMARKS.

#### **CLASS 41—EDUCATION AND ENTERTAINMENT**

FOR PROVIDING ONLINE PUBLICATIONS, NAMELY, BULLETINS RELATING TO INTELLECTUAL PROPERTY; EDUCATIONAL SERVICES, NAMELY, CONDUCTING DISTANCE LEARNING INSTRUCTION ON TOPICS OF INTELLECTUAL PROPERTY, CONDUCTING CONFERENCES, LECTURES, PRESENTATIONS AND SEMINARS IN THE FIELD OF INTELLECTUAL PROPERTY, CONDUCTING PROGRAMS IN THE FIELD OF INTELLECTUAL PROPERTY; CONDUCTING WORKSHOPS, EDUCATIONAL CONFERENCES, AND PROGRAMS THAT PROMOTE INTELLECTUAL PROPERTY, AND DISTRIBUTING WRITTEN AND DIGITAL COURSE MATERIALS IN CONNECTION THEREWITH; PROVIDING A WEBSITE FEATURING INFORMATIONAL, NONDOWNLOADABLE AUDIO AND MULTI-MEDIA PRESENTATIONS IN THE FIELD OF EDUCATING INDIVIDUALS AND BUSINESSES ABOUT INTELLECTUAL PROPERTY (U.S. CLS. 100, 101 AND 107).  
FIRST USE 7-22-2009; IN COMMERCE 7-22-2009.

#### **CLASS 45—PERSONAL AND LEGAL SERVICES**

FOR PROVIDING AN ON-LINE DATABASE FEATURING INFORMATION ON INTELLECTUAL PROPERTY AND ANNOTATED LINKS TO OTHER INFORMATION ON INTELLECTUAL PROPERTY FROM OTHER SOURCES; PROVIDING NEWS IN THE FIELD OF INTELLECTUAL PROPERTY; PROVIDING A WEBSITE FEATURING INFORMATION IN THE FIELD OF INTELLECTUAL PROPERTY (U.S. CLS. 100 AND 101).  
FIRST USE 7-22-2009; IN COMMERCE 7-22-2009.  
MICHAEL KEATING, EXAMINING ATTORNEY

SN 85-042,959. AMERICAN INTELLECTUAL PROPERTY LAW ASSOCIATION, INC., ARLINGTON, VA. FILED 5-19-2010.



NO CLAIM IS MADE TO THE EXCLUSIVE RIGHT TO USE "©" AS PART OF THE DESIGN ELEMENT OF THE MARK, APART FROM THE MARK AS SHOWN.

THE MARK CONSISTS OF A STYLIZED TREE WITH A REACHING HAND REPRESENTING THE TRUNK AND BRANCHES, SWIRLS AS LEAVES, AND THE FOLLOWING SYMBOLS AS BLOOMS: TECHNOLOGY SYMBOLS RELATED TO PATENTS INCLUDING A BEAKER CONTAINING A REACTING LIQUID, AN ATOMIC MODEL, A GEAR, A SERIES OF WAVY LINES REPRESENTING A WAVEFORM, 2 LEAVES REPRESENTING BIOTECHNOLOGY AND GREEN TECHNOLOGY, AND A SERIES OF BINARY NUMBERS REPRESENTING COMPUTER LANGUAGE AND SOFTWARE; ARTISTIC SYMBOLS RELATED TO COPYRIGHT INCLUDING A TREBLE CLEF, A BASS CLEF, AND A SECTION OF PHOTOGRAPHIC FILM; AND THE TRADITIONAL CIRCLE R SYMBOL RELATING TO TRADEMARKS.

#### CLASS 9—ELECTRICAL AND SCIENTIFIC APPARATUS

FOR PRE-RECORDED CDS AND DVDS OF LECTURES AND SEMINARS IN THE FIELD OF INTELLECTUAL PROPERTY; DOWNLOADABLE VIDEO MATERIAL FEATURING INFORMATION IN THE FORM OF DOWNLOADABLE EDUCATIONAL/INFORMATIONAL COMMUNICATIONS IN THE FIELD OF INTELLECTUAL PROPERTY (U.S. CLS. 21, 23, 26, 36 AND 38).

#### CLASS 25—CLOTHING

FOR CLOTHING, NAMELY, SHIRTS, HATS, AND OUTERWEAR, NAMELY, JACKETS (U.S. CLS. 22 AND 39).  
MICHAEL KEATING, EXAMINING ATTORNEY

SN 85-043,873. WE ARE YOGA, LLC, SPRING, TX. FILED 5-20-2010.



NO CLAIM IS MADE TO THE EXCLUSIVE RIGHT TO USE "YOGA WEAR" AS TO CLASS 025 AND "YOGA" AS TO CLASS 028, APART FROM THE MARK AS SHOWN.

THE MARK CONSISTS OF FEMALE SILHOUETTES DEPICTED IN VARIOUS POSITIONS THAT CREATE THE WORD "YOGA" AND THE WORD "WEAR" BENEATH THE SILHOUETTE THAT CREATES THE "A" IN THE WORD "YOGA" ALL ON A RECTANGULAR BACKGROUND.

#### CLASS 25—CLOTHING

FOR TEE SHIRTS, SWEATSHIRTS, PANTS, LEGGINGS, SHORTS, JACKETS, BODY SHIRTS, CAPRI PANTS, DANCE SHOES, GYMNASTIC SHOES, LEISURE SHOES, LONG-SLEEVED SHIRTS, LOUNGE PANTS, PIQUE SHIRTS, POLO SHIRTS, STRETCH PANTS, SWEAT PANTS, YOGA PANTS, YOGA SHIRTS (U.S. CLS. 22 AND 39).

#### CLASS 28—TOYS AND SPORTING GOODS

FOR PERSONAL EXERCISE MATS, STRETCH BANDS USED FOR YOGA AND PHYSICAL FITNESS PURPOSES, YOGA BLOCKS, YOGA BOARDS, YOGA MATS, YOGA STRAPS (U.S. CLS. 22, 23, 38 AND 50).  
MAYUR VAGHANI, EXAMINING ATTORNEY

SN 85-044,612. UNITED STATES DEPARTMENT OF HOMELAND SECURITY, WASHINGTON, DC. FILED 5-21-2010.

vUSA

THE MARK CONSISTS OF STANDARD CHARACTERS WITHOUT CLAIM TO ANY PARTICULAR FONT, STYLE, SIZE, OR COLOR.

#### CLASS 42—SCIENTIFIC AND COMPUTER SERVICES

FOR PROVIDING A WEBSITE AND SOFTWARE WIDGETS THAT FEATURE TECHNOLOGY THAT ENABLES THE SECURE EXCHANGE OF INFORMATION BETWEEN FIRST RESPONDERS AND OTHER FEDERAL, STATE, LOCAL, TRIBAL AND PRIVATE ENTITIES FOR PURPOSES OF ASSISTING WITH EMERGENCY PREPAREDNESS BY ENHANCING AND FACILITATING SITUATIONAL AWARENESS; PROVIDING A WEB HOSTING PLATFORM AND SOFTWARE WIDGETS FOR ENABLING USERS TO LIST, SHARE, AND VIEW INFORMATION DESCRIBING SHELTER STATUS, LOCATIONS OF POWER OUTAGES, ROAD CLOSURES, OR GEOGRAPHIC AND OTHER INFORMATION TO SUPPORT EMERGENCY RESPONSE AND PUBLIC SAFETY (U.S. CLS. 100 AND 101).

#### CLASS 45—PERSONAL AND LEGAL SERVICES

FOR PROVIDING INFORMATION CONCERNING HOMELAND SAFETY AND SECURITY ISSUES AND EMERGENCY RESPONSES (U.S. CLS. 100 AND 101).  
NAPOLEON SHARMA, EXAMINING ATTORNEY

SN 85-045,264. XL GROUP INC., DOYLESTOWN, PA. FILED 5-21-2010.

SN 85-048,325. OFFICE PAPER SYSTEMS, INC., GAITHERSBURG, MD. FILED 5-26-2010.

# ClaritySM

THE MARK CONSISTS OF STANDARD CHARACTERS WITHOUT CLAIM TO ANY PARTICULAR FONT, STYLE, SIZE, OR COLOR.

## CLASS 9—ELECTRICAL AND SCIENTIFIC APPARATUS

FOR COMPUTER HARDWARE AND COMPUTER SOFTWARE AND HARDWARE FOR USE IN SAMPLE MANAGEMENT, NAMELY, FOR MANAGING SAMPLE DISTRIBUTION, TRACKING SAMPLES AND PROVIDING INFORMATION ON PRODUCT SAMPLES TO ENSURE EFFICIENT SAMPLE UTILIZATION AND REGULATORY COMPLIANCE (U.S. CLS. 21, 23, 26, 36 AND 38).

FIRST USE 12-31-2009; IN COMMERCE 12-31-2009.

## CLASS 42—SCIENTIFIC AND COMPUTER SERVICES

FOR SOFTWARE AS A SERVICE (SAAS) SERVICES, NAMELY, HOSTING SOFTWARE FOR USE BY OTHERS FOR USE IN SAMPLE MANAGEMENT, NAMELY, FOR MANAGING SAMPLE DISTRIBUTION, TRACKING SAMPLES AND PROVIDING INFORMATION ON PRODUCT SAMPLES TO ENSURE EFFICIENT SAMPLE UTILIZATION AND REGULATORY COMPLIANCE (U.S. CLS. 100 AND 101).

FIRST USE 12-31-2009; IN COMMERCE 12-31-2009.  
ELLEN PERKINS, EXAMINING ATTORNEY

---

SN 85-045,410. FUJI FOOD PRODUCTS, INC., SANTA FE SPRINGS, CA. FILED 5-21-2010.

## A Trend to Healthy Eating

THE MARK CONSISTS OF STANDARD CHARACTERS WITHOUT CLAIM TO ANY PARTICULAR FONT, STYLE, SIZE, OR COLOR.

## CLASS 29—MEATS AND PROCESSED FOODS

FOR ASIAN-STYLE PREPARED MEALS CONSISTING PRIMARILY OF MEAT, FISH, POULTRY OR VEGETABLES; INSTANT OR PRE-COOKED SOUP; PREPARED VEGETABLES; ASIAN-STYLE PREPARED APPETIZERS CONSISTING PRIMARILY OF MEAT, FISH, POULTRY OR VEGETABLES (U.S. CL. 46).

## CLASS 30—STAPLE FOODS

FOR ASIAN CONDIMENTS, NAMELY, PREPARED WASABI, PREPARED GINGER, ASIAN SAUCES; SUSHI (U.S. CL. 46).  
JULIE GUTTADAURO, EXAMINING ATTORNEY



OWNER OF U.S. REG. NO. 3,758,729.

THE COLOR(S) BLUE, DARK BLUE, GREEN, LIGHT GREEN AND DARK GREEN IS/ARE CLAIMED AS A FEATURE OF THE MARK.

THE MARK CONSISTS OF A MAP OF EARTH PROJECTED ON A HUMAN BUST WHEREIN THE LANDMASS ON THE HEAD IS LIGHT GREEN, LANDMASS ON THE NECK IS GREEN, THE INNER LEFT EAR, LEFT EYE, AREA UNDER THE LIP IS DARK GREEN, THE WATER MASS OF THE MAP ON THE HEAD IS BLUE, WATER MASS ON THE NECK IS DARK BLUE, AND THE INNER RIGHT EAR, RIGHT EYE, MOUTH AND NOSE IS DARK BLUE. THE WORDING "PROTECTING YOUR ENVIRONMENT AND YOUR IDENTITY IS LIGHT GREEN AND OPSUS.COM" IS DARK BLUE.

## CLASS 25—CLOTHING

FOR WEARING APPAREL, NAMELY, T-SHIRTS, POLO SHIRTS, SWEATSHIRTS AND HATS (U.S. CLS. 22 AND 39).

## CLASS 40—MATERIAL TREATMENT

FOR DOCUMENT DESTRUCTION SERVICES AND RECYCLING SERVICES (U.S. CLS. 100, 103 AND 106).  
MICHELE SWAIN, EXAMINING ATTORNEY

---

SN 85-048,335. OFFICE PAPER SYSTEMS, INC., GAITHERSBURG, MD. FILED 5-26-2010.

## PROTECTED MY ENVIRONMENT AND MY IDENTITY

THE MARK CONSISTS OF STANDARD CHARACTERS WITHOUT CLAIM TO ANY PARTICULAR FONT, STYLE, SIZE, OR COLOR.

OWNER OF U.S. REG. NO. 3,758,729.

## CLASS 25—CLOTHING

FOR WEARING APPAREL, NAMELY, T-SHIRTS, POLO SHIRTS, SWEATSHIRTS, AND HATS (U.S. CLS. 22 AND 39).

## CLASS 40—MATERIAL TREATMENT

FOR DOCUMENT DESTRUCTION SERVICES AND RECYCLING SERVICES (U.S. CLS. 100, 103 AND 106).  
MICHELE SWAIN, EXAMINING ATTORNEY

SN 85-049,600. HOT STUFF FOODS, LLC, SIOUX FALLS, SD.  
FILED 5-27-2010.

SN 85-050,812. CISCO TECHNOLOGY, INC., SAN JOSE, CA.  
FILED 5-28-2010.

## HOT STUFF FOODS XPRESS

THE MARK CONSISTS OF STANDARD CHARACTERS WITHOUT CLAIM TO ANY PARTICULAR FONT, STYLE, SIZE, OR COLOR.

OWNER OF U.S. REG. NOS. 1,273,749, 3,112,651 AND OTHERS.

NO CLAIM IS MADE TO THE EXCLUSIVE RIGHT TO USE "FOODS", APART FROM THE MARK AS SHOWN.

### CLASS 29—MEATS AND PROCESSED FOODS

FOR CORN DOGS (U.S. CL. 46).

### CLASS 30—STAPLE FOODS

FOR FOOD PRODUCTS, NAMELY, PIZZA, BREAKFAST SANDWICHES, BREAKFAST BISCUITS, MUFFINS, CALZONES, SANDWICHES, WRAP DOGS, NAMELY, HOT DOGS WRAPPED IN DOUGH, BREADSTICKS AND FILLED BREADSTICKS, HAMBURGER SANDWICHES AND HOT SANDWICHES, COLD SANDWICHES, BREAKFAST SANDWICHES, BURRITOS, TACOS, ENCHILADAS, NACHOS, EGG ROLLS; BAKERY GOODS, NAMELY, DANISHES, BROWNIES, CINNAMON ROLLS, DONUTS, BISCUITS AND COOKIES (U.S. CL. 46).

MARGARET POWER, EXAMINING ATTORNEY

---

SN 85-050,734. NANOICE, INC., MILL CREEK, WA. FILED 5-28-2010.

## UPTAKEENERGY

THE MARK CONSISTS OF STANDARD CHARACTERS WITHOUT CLAIM TO ANY PARTICULAR FONT, STYLE, SIZE, OR COLOR.

### CLASS 11—ENVIRONMENTAL CONTROL APPARATUS

FOR ICE MAKING MACHINES (U.S. CLS. 13, 21, 23, 31 AND 34).

### CLASS 30—STAPLE FOODS

FOR ICE (U.S. CL. 46).  
REBECCA GILBERT, EXAMINING ATTORNEY

## TOGETHER

THE MARK CONSISTS OF STANDARD CHARACTERS WITHOUT CLAIM TO ANY PARTICULAR FONT, STYLE, SIZE, OR COLOR.

### CLASS 9—ELECTRICAL AND SCIENTIFIC APPARATUS

FOR COMPUTER HARDWARE AND COMPUTER SOFTWARE, NAMELY, COMPUTER SOFTWARE FOR CUSTOMER SUPPORT, CUSTOMER SERVICE MANAGEMENT AND TECHNICAL SUPPORT; COMPUTER HARDWARE AND SOFTWARE FOR INTERCONNECTING, MANAGING, SECURING AND OPERATING LOCAL AND WIDE AREA NETWORKS AND TELEPHONY SYSTEMS; COMPUTER HARDWARE AND SOFTWARE FOR TRANSMITTING, SECURING, STORING, UPLOADING, POSTING, DISPLAYING, TAGGING, EDITING, ORGANIZING AND PROCESSING DATA, AUDIO AND VIDEO; TELEPHONES; WIRELESS COMMUNICATIONS DEVICES, NAMELY, WIRELESS HARDWARE AND SOFTWARE FOR THE TRANSMISSION OF DATA, AUDIO, AND VIDEO; CALL PROCESSING SOFTWARE FOR THE TRANSMISSION OF DATA, VIDEO, AND AUDIO; DOWNLOADABLE ELECTRONIC INSTRUCTIONAL MATERIALS, NAMELY, MANUALS, GUIDES, TEST MATERIALS, AND MAGAZINES IN THE FIELD OF TECHNOLOGY; COMPUTER SOFTWARE FOR USE IN SOCIAL NETWORKING; ELECTRONIC DEVICES, NAMELY, HANDHELD COMPUTERS AND SOFTWARE FOR RECORDING, ORGANIZING, TRANSMITTING, STORING AND/OR REVIEWING VOICE, AUDIO, VIDEO, AND/OR DATA FILES; NETWORK ROUTERS; COMPUTER SWITCHES; COMPUTER NETWORK ADAPTERS; COMPUTER SERVERS; COMMUNICATIONS SERVERS; COMPUTER HARDWARE CONTAINING NETWORK SECURITY FUNCTIONALITY, INCLUDING FIREWALLS, DATA ENCRYPTION, AND/OR INTEROPERABILITY WITH NETWORK SECURITY PROTOCOLS; DIGITAL VIDEO RECORDERS; SET-TOP BOXES; HARDWARE AND OPERATING SOFTWARE FOR CONFERENCING SERVICES; CAMCORDERS (U.S. CLS. 21, 23, 26, 36 AND 38).

### CLASS 38—COMMUNICATION

FOR TELECOMMUNICATIONS SERVICES, NAMELY, TRANSMISSION OF INFORMATION, VOICE, VIDEO AUDIO, DATA, DOCUMENTS, IMAGES AND SOFTWARE APPLICATIONS VIA THE INTERNET; TELECOMMUNICATION SERVICES, NAMELY, PROVIDING WEB-BASED CONFERENCING; TELECOMMUNICATION SERVICES, NAMELY, PROVIDING CONSUMERS WITH SECURE REMOTE ACCESS VIA THE INTERNET TO PRIVATE COMPUTER NETWORKS; TELECOMMUNICATIONS SERVICES, NAMELY, PROVIDING INTERNET ACCESS TO DATA OR DOCUMENTS STORED ELECTRONICALLY FOR REMOTE CONSULTATION ALLOWING REMOTE USERS TO ACCESS JOINTLY SHARED DOCUMENTS, DATA, CALENDARS, TASK LISTS, ADDRESS BOOKS AND DISCUSSION FORUMS; PROVIDING INFORMATION VIA LOCAL AND GLOBAL COMPUTER NETWORKS ABOUT TELECOMMUNICATIONS AND TELEPHONY SYSTEMS; BROADCASTING PROGRAMS VIA COMPUTER NETWORKS; PROVIDING TELECOMMUNICATIONS SERVICES, NAMELY, WEB CONFERENCING SERVICES; INTERNET TELEPHONY SERVICES (U.S. CLS. 100, 101 AND 104).

**CLASS 41—EDUCATION AND ENTERTAINMENT**

FOR PROVIDING OF TRAINING IN THE FIELDS OF TECHNOLOGY; EDUCATIONAL SERVICES, NAMELY, CONFERENCES, TRAINING COURSES, TESTING, WORKSHOPS, AND DISTRIBUTING COURSE MATERIALS IN CONNECTION THEREWITH, ALL IN THE FIELDS OF TECHNOLOGY (U.S. CLS. 100, 101 AND 107).

**CLASS 42—SCIENTIFIC AND COMPUTER SERVICES**

FOR DESIGN AND DEVELOPMENT OF COMPUTER HARDWARE AND SOFTWARE; ON-LINE SERVICES, NAMELY, PROVIDING TECHNICAL INFORMATION VIA COMPUTER NETWORKS IN THE FIELD OF COMPUTER HARDWARE AND SOFTWARE, NETWORKING, NAMELY, COMPUTER NETWORK DESIGNS AND TELECOMMUNICATIONS, TELEPHONY AND NETWORKING TECHNOLOGY; PROVIDING TECHNICAL CONSULTATION IN CONNECTION WITH COMPUTER HARDWARE, COMPUTER SOFTWARE, COMPUTER NETWORKING EQUIPMENT, TELECOMMUNICATIONS EQUIPMENT, IP TELEPHONY, COMPUTER NETWORK DESIGN, PROVIDING COMPUTER CONSULTATION SERVICES ABOUT COMPUTER STORAGE DESIGN, SECURITY OF COMPUTER NETWORKS, AND VOICE AND WIRELESS COMMUNICATIONS; APPLICATION SERVICE PROVIDER (ASP), NAMELY, HOSTING THE SOFTWARE APPLICATIONS OF OTHERS; COMPUTER CONSULTING SERVICES; COMPUTER NETWORK DESIGN FOR OTHERS (U.S. CLS. 100 AND 101).  
TASNEEM HUSSAIN, EXAMINING ATTORNEY

SN 85-052,022. TUTTLE, JAMES S., DBA THE CAPE CAT, SOUTH YARMOUTH, MA. FILED 6-1-2010.

# Cape Cod Cat

THE MARK CONSISTS OF STANDARD CHARACTERS WITHOUT CLAIM TO ANY PARTICULAR FONT, STYLE, SIZE, OR COLOR.

OWNER OF U.S. REG. NO. 2,095,086.

**CLASS 18—LEATHER GOODS**

FOR TOTE BAGS (U.S. CLS. 1, 2, 3, 22 AND 41).

**CLASS 21—HOUSEWARES AND GLASS**

FOR PLATES, BOWLS, MUGS, AND ORNAMENTAL PLATES (U.S. CLS. 2, 13, 23, 29, 30, 33, 40 AND 50).

**CLASS 25—CLOTHING**

FOR T-SHIRTS, SWEATSHIRTS, CAPS, TIES, BOXER SHORTS, NIGHT SHIRTS, AND HEAD BANDS (U.S. CLS. 22 AND 39).

BARNEY CHARLON, EXAMINING ATTORNEY

SN 85-051,075. MORRIS NUTT FINANCIAL, LLC, CORDOVA, TN. FILED 5-31-2010.

## THE LAWS OF FINANCIAL SUCCESS

THE MARK CONSISTS OF STANDARD CHARACTERS WITHOUT CLAIM TO ANY PARTICULAR FONT, STYLE, SIZE, OR COLOR.

NO CLAIM IS MADE TO THE EXCLUSIVE RIGHT TO USE "FINANCIAL", APART FROM THE MARK AS SHOWN.

**CLASS 16—PAPER GOODS AND PRINTED MATTER**

FOR PAPER GOODS AND PRINTED MATERIAL, NAMELY, BOOKS IN THE FIELD OF FINANCIAL TIPS AND INFORMATION (U.S. CLS. 2, 5, 22, 23, 29, 37, 38 AND 50).

**CLASS 41—EDUCATION AND ENTERTAINMENT**

FOR EDUCATION SERVICES, NAMELY, PUBLICATION OF BOOKS, PUBLICATION OF ELECTRONIC BOOKS AND JOURNALS ON-LINE FOR CONSUMERS (U.S. CLS. 100, 101 AND 107).

KRISTINA MORRIS, EXAMINING ATTORNEY

SN 85-052,728. NOWNESS, LLC, NEW YORK, NY. FILED 6-2-2010.

# NOWNESS

THE MARK CONSISTS OF STANDARD CHARACTERS WITHOUT CLAIM TO ANY PARTICULAR FONT, STYLE, SIZE, OR COLOR.

PRIORITY CLAIMED UNDER SEC. 44(D) ON FRANCE APPLICATION NO. 09/3697463, FILED 12-9-2009, REG. NO. 093697463, DATED 12-9-2009, EXPIRES 12-9-2019.

**CLASS 35—ADVERTISING AND BUSINESS**

FOR ADVERTISING SERVICES AND PROMOTIONAL SERVICES BY ELECTRONIC MEANS; RENTAL OF ADVERTISING SPACE; PUBLICATION OF ADVERTISING PUBLICITY TEXTS; DIRECT MAIL ADVERTISING SERVICES; ON-LINE ADVERTISING ON A COMPUTER NETWORK; OPINION POLLING FOR BUSINESS OR ADVERTISING PURPOSES; CONDUCTING MARKETING STUDIES; SERVICES RELATING TO COMMERCIAL PROMOTION ACTIVITY OF ALL KINDS, NAMELY, PROMOTING THE GOODS AND SERVICES OF OTHERS THROUGH THE ARRANGING FOR SPONSORS AND PROMOTIONAL INFORMATION CAMPAIGNS IN THE FIELD OF THE FASHION INDUSTRY (U.S. CLS. 100, 101 AND 102).



**CLASS 38—COMMUNICATION**

FOR COMMUNICATION AND TELECOMMUNICATION SERVICES, NAMELY, PROVIDING TELECOMMUNICATION ACCESS TO COMPUTER TERMINALS, COMPUTER PERIPHERAL DEVICES, ELECTRONIC EQUIPMENT, AND DIGITAL EQUIPMENT; TRANSMISSION AND DISSEMINATION OF DATA, SOUND, AND IMAGES VIA A GLOBAL COMPUTER NETWORK AND THE INTERNET; PROVIDING MULTIPLE USER ACCESS TO PROPRIETARY INFORMATION VIA COMPUTER TERMINALS OR BY ANY OTHER TELECOMMUNICATIONS MEDIUM, AND VIA THE INTERNET; INTERACTIVE COMMUNICATION SERVICES BEING INTERACTIVE DELIVERY OF VIDEO, AUDIO, AND IMAGES OVER A DIGITAL NETWORK AND BROADCASTING OF MULTIMEDIA PROGRAMS BY COMPUTERIZATION OF TEXT, STILL OR MOVING IMAGES, AND MUSICAL SOUND; PROVIDING INTERNET FORUMS FOR THE TRANSMISSION OF MESSAGES AMONG COMPUTER USERS; PROVIDING TELECOMMUNICATIONS CONNECTIONS TO THE INTERNET OR DATABASES; PROVIDING ACCESS TO ELECTRONIC SITES ON COMPUTERIZED GLOBAL NETWORK TO BROADCAST INFORMATION AND DOCUMENTS OF ALL KINDS (U.S. CLS. 100, 101 AND 104).

**CLASS 41—EDUCATION AND ENTERTAINMENT**

FOR ENTERTAINMENT SERVICES, NAMELY, CONDUCTING AND ARRANGING EVENTS IN RELATION WITH THE FASHION INDUSTRY IN THE FIELDS OF FASHION AND FASHION MERCHANDISING; PUBLISHING SERVICES AND ELECTRONIC PUBLICATION OF TEXTS, OTHER THAN ADVERTISING TEXTS, NAMELY, PUBLICATION OF BOOKS, NEWSPAPERS, JOURNALS, PERIODICALS, CATALOGS, AND PHOTOGRAPHS, PHOTOGRAPHIC REPORTING OF ALBUMS AND IMAGES (U.S. CLS. 100, 101 AND 107).

JACLYN KIDWELL WALKER, EXAMINING ATTORNEY

**CLASS 35—ADVERTISING AND BUSINESS**

FOR PROVIDING AN ONLINE COMMERCIAL INFORMATION DIRECTORY ON THE INTERNET FEATURING A CALENDAR OF EVENTS AND DIRECTORY OF CHURCHES, MINISTRIES, OTHER RELIGIOUS ORGANIZATIONS, AND ADVERTISEMENTS; ADVERTISING AND DIRECTORY SERVICES, NAMELY, PROMOTING THE SERVICES OF RELIGIOUS ORGANIZATIONS BY PROVIDING A WEB PAGE FEATURING LINKS TO THE WEBSITES OF RELIGIOUS ORGANIZATIONS; CLASSIFIED ADVERTISING SERVICES; OPERATING ON-LINE MARKETPLACES FEATURING RELIGIOUS GOODS AND SERVICES; ADVERTISING, MARKETING AND PROMOTION SERVICES AND RELATED CONSULTING; PROMOTING THE GOODS AND SERVICES OF OTHERS THROUGH SEARCH ENGINE REFERRAL TRAFFIC ANALYSIS AND REPORTING; INTERNET ADVERTISING AND MARKETING SERVICES, NAMELY, SEARCH ENGINE MARKETING, MARKETING VIA SOCIAL NETWORKING WEBSITES; PROVIDING A WEB SITE FOR RELIGIOUS ORGANIZATIONS TO SELL MERCHANDISE VIA CLASSIFIED ADVERTISEMENTS; DISSEMINATION OF ADVERTISING AND MARKETING FOR RELIGIOUS ORGANIZATIONS; CONSULTATION IN FIELD OF SEARCH ENGINE MARKETING; PROVIDING AN ONLINE SEARCHABLE DATABASE FEATURING THE LINKS TO AND CONTACT INFORMATION OF RELIGIOUS ORGANIZATIONS FOR THE PURPOSE OF MATCHING INDIVIDUALS LOOKING FOR RELIGIOUS ORGANIZATIONS THAT MEET THEIR CRITERIA; BUSINESS MONITORING SERVICES, NAMELY, TRACKING WEB SITES OF OTHERS TO PROVIDE DETAILS ABOUT USER CLICK TRAFFIC OR VISITS TO THE WEB SITE (U.S. CLS. 100, 101 AND 102).

**CLASS 38—COMMUNICATION**

FOR PROVIDING AN ONLINE FORUM FOR USERS TO DISCUSS RELIGIOUS IDEAS, ISSUES AND ORGANIZATIONS; PROVIDING A WEBSITE FEATURING GENERAL INFORMATION ABOUT RELIGIONS (U.S. CLS. 100, 101 AND 104).

**CLASS 42—SCIENTIFIC AND COMPUTER SERVICES**

FOR COMPUTER SERVICES, NAMELY, PLANNING, DESIGNING, DEVELOPING, OPTIMIZING, AND MAINTAINING WEBSITES AND WEB-BASED TECHNOLOGY PLATFORMS; APPLICATION SERVICE PROVIDER, NAMELY, HOSTING, MANAGING, DEVELOPING AND MAINTAINING APPLICATIONS, SOFTWARE, WEBSITES, AND TECHNOLOGY PLATFORMS IN THE FIELDS OF MARKETING, ADVERTISING AND RELIGION; COMPUTER SERVICES, NAMELY, HOSTING ON-LINE INTERACTIVE PUBLIC CALENDARS THAT ALLOW RELIGIOUS ORGANIZATIONS TO SHARE EVENT SCHEDULES; COMPUTER SERVICES, NAMELY, SEARCH ENGINE OPTIMIZATION; CONSULTATION SERVICES IN THE FIELD OF SEARCH ENGINE OPTIMIZATION; COMPUTER SERVICES, NAMELY, HOSTING ONLINE WEB FACILITIES FOR OTHERS FOR ORGANIZING AND CONDUCTING ON-LINE MEETINGS, GATHERINGS, AND INTERACTIVE DISCUSSIONS; COMPUTER SERVICES IN THE NATURE OF CUSTOMIZED WEB PAGES FEATURING USER-DEFINED INFORMATION, PERSONAL PROFILES AND INFORMATION; TRACKING AND REPORTING OF ONLINE WEBSITE TRAFFIC TO DETERMINE THE TECHNOLOGICAL EFFECTIVENESS OF THE WEBSITES FOR NON-BUSINESS PURPOSES (U.S. CLS. 100 AND 101).

**CLASS 45—PERSONAL AND LEGAL SERVICES**

FOR PROVIDING A WEBSITE AND ON-LINE SEARCHABLE DATABASE FEATURING INFORMATION ABOUT AND DESCRIPTIONS OF RELIGIOUS ORGANIZATIONS; PROVIDING A WEBSITE FEATURING INFORMATION ABOUT RELIGION (U.S. CLS. 100 AND 101).

JULIE VEPPUMTHARA, EXAMINING ATTORNEY

SN 85-052,755, EVENING POST PUBLISHING NEWSPAPER GROUP, INC., CHARLESTON, SC. FILED 6-2-2010.

**YOURFAITH**

THE MARK CONSISTS OF STANDARD CHARACTERS WITHOUT CLAIM TO ANY PARTICULAR FONT, STYLE, SIZE, OR COLOR.

SN 85-053,521. SEA CLIFF VENTURES INC., SWIEQI, MALTA, FILED 6-3-2010.

SN 85-054,371. NIKE, INC., BEAVERTON, OR. FILED 6-3-2010.

# IHOOKUP.COM

THE MARK CONSISTS OF STANDARD CHARACTERS WITHOUT CLAIM TO ANY PARTICULAR FONT, STYLE, SIZE, OR COLOR.

## CLASS 38—COMMUNICATION

FOR PROVIDING AN ONLINE CHAT ROOM AND WEBCAM CHAT ROOM FOR THE TRANSMISSION OF MESSAGES, VIDEOS AND PHOTOGRAPHS AMONG COMPUTER USERS INTERESTED IN MEETING OTHER PEOPLE (U.S. CLS. 100, 101 AND 104).

## CLASS 41—EDUCATION AND ENTERTAINMENT

FOR ENTERTAINMENT SERVICES, NAMELY, PROVIDING A WEBSITE FEATURING ADULT-THEMED NON-DOWNLOADABLE PHOTOGRAPHS, TEXT, VIDEOS AND LIVE WEBCAM VIDEOS; ENTERTAINMENT SERVICES, NAMELY, PROVIDING WEBSITES FEATURING AN ONLINE MONTHLY COLUMN IN THE FIELD OF SEXUAL ADVICE; ENTERTAINMENT SERVICES, NAMELY, CONDUCTING CONTESTS (U.S. CLS. 100, 101 AND 107).

## CLASS 45—PERSONAL AND LEGAL SERVICES

FOR ONLINE ADULT DATING, SOCIAL INTRODUCTION, SOCIAL NETWORK AND DATE MATCHING SERVICES PROVIDED OVER THE INTERNET (U.S. CLS. 100 AND 101).

DANIEL CAPSHAW, EXAMINING ATTORNEY

SN 85-053,775. TOPET (H.K.) CO., LIMITED, KWUN TONG, KOWLOON, HONG KONG, FILED 6-3-2010.

# iGroom

THE MARK CONSISTS OF STANDARD CHARACTERS WITHOUT CLAIM TO ANY PARTICULAR FONT, STYLE, SIZE, OR COLOR.

## CLASS 8—HAND TOOLS

FOR GROOMING UTENSILS FOR PETS, NAMELY, SHEDDING BLADES, RAKES, NAIL CLIPPERS AND GROOMING SHEARS (U.S. CLS. 23, 28 AND 44).

## CLASS 21—HOUSEWARES AND GLASS

FOR GROOMING UTENSILS FOR PETS, NAMELY, PET BRUSHES, PIN BRUSHES, SLICKER BRUSHES, DOG COMBS (U.S. CLS. 2, 13, 23, 29, 30, 33, 40 AND 50).  
NATALIE POLZER, EXAMINING ATTORNEY



THE MARK CONSISTS OF A SHIELD COMPOSED OF THREE PYRAMIDS OVERLAPPING A TRIANGLE.

## CLASS 18—LEATHER GOODS

FOR BAGS, NAMELY, ALL-PURPOSE SPORTS BAGS, TOTE BAGS, DUFFLE BAGS, MESSENGER BAGS, BACKPACKS, WAIST PACKS, PURSES, UMBRELLAS, LUGGAGE, WALLETS, BRIEFCASE-TYPE PORTFOLIOS, COSMETIC AND TOILETRY CASES SOLD EMPTY, BAGS FOR CARRYING SHOES (U.S. CLS. 1, 2, 3, 22 AND 41).

## CLASS 25—CLOTHING

FOR FOOTWEAR; CLOTHING FOR ATHLETIC USE, NAMELY, PADDED SHORTS, PADDED PANTS, PADDED SHIRTS, PADDED ELBOW COMPRESSION SLEEVES; CLOTHING, NAMELY, SHORTS, PANTS, SHIRTS, T-SHIRTS, TANK TOPS, JERSEYS, HOODED TOPS; SWEATSHIRTS, PULLOVERS, JACKETS, SWEAT-PANTS, BANDANAS, GLOVES AND HEADWEAR (U.S. CLS. 22 AND 39).

## CLASS 28—TOYS AND SPORTING GOODS

FOR SPORTS EQUIPMENT, NAMELY, SOCCER BALLS, SHIN GUARDS, PROTECTIVE PADDING FOR PLAYING SOCCER AND GOALKEEPER'S GLOVES (U.S. CLS. 22, 23, 38 AND 50).

SUSAN LESLIE DUBOIS, EXAMINING ATTORNEY

SN 85-054,659. HERMES INTERNATIONAL, 75008 PARIS, FRANCE, FILED 6-4-2010.



PRIORITY CLAIMED UNDER SEC. 44(D) ON FRANCE APPLICATION NO. 093697055, FILED 12-8-2009, REG. NO. 093697055, DATED 12-8-2009, EXPIRES 12-8-2019.

OWNER OF U.S. REG. NOS. 368,785, 370,082 AND OTHERS.

NO CLAIM IS MADE TO THE EXCLUSIVE RIGHT TO USE "PARIS", APART FROM THE MARK AS SHOWN.

THE MARK CONSISTS OF TWO CONCENTRIC CIRCLES WHICH CONTAIN THE WORDS "HERMÈS PARIS" IN A CIRCULAR FASHION WITH TWO DIAMONDS SEPARATING THE WORDS.

### **CLASS 3—COSMETICS AND CLEANING PREPARATIONS**

FOR PERFUME, TOILET WATER, PERFUMED WATER, ESSENTIAL OILS FOR PERSONAL USE, COSMETICS; MAKE-UP PRODUCTS, NAMELY, COSMETICS; HAIR AND BODY LOTIONS, SOAPS, DENTIFRICES, DEODORANTS FOR PERSONAL USE, TISSUES IMPREGNATED WITH COSMETIC LOTIONS, SHOWER GELS, SHAMPOOS, BEAUTY CREAMS FOR BODY USE, SHAVING CREAMS, AFTER-SHAVE LOTIONS, AFTER-SHAVE BALMS, COSMETIC PREPARATIONS FOR BATHS, COSMETIC CREAMS, LOTIONS FOR COSMETIC PURPOSES, NON-MEDICATED TOILETRIES, BLEACHING PREPARATIONS FOR LAUNDRY USE; CLEANING, POLISHING AND SCOURING PREPARATIONS; CLEANING PRODUCTS, NAMELY, CLEANING PREPARATIONS; OILS FOR CLEANING PURPOSES; LEATHER BLEACHING PREPARATIONS, POLISHING CREAMS, SHOE WAX; CREAMS FOR SHOES, CREAMS FOR LEATHER, SHOEMAKERS' WAX (U.S. CLS. 1, 4, 6, 50, 51 AND 52).

### **CLASS 6—METAL GOODS**

FOR METAL LOCKS FOR LEATHER BAGS AND POUCHES; METAL LOCKS FOR LEATHERWARE IN LEATHER OR IMITATION OF LEATHER, NAMELY, POCKET WALLETS, PURSES, CREDIT CARD CASES, BUSINESS CARD CASES, BRIEFCASES, KEY HOLDERS, CHECK-BOOK HOLDERS, PASSPORT HOLDERS, PHOTOGRAPH CASES AND TOILETRY BAGS SOLD EMPTY; BOXES OF COMMON METAL, METAL BOX FASTENERS, METAL BOTTLE CAPS AND CLOSURES, METAL DOORKNOBS, METAL PADLOCKS, FERRULES OF METAL FOR WALKING STICKS AND UMBRELLAS, METAL MONEY BOXES (U.S. CLS. 2, 12, 13, 14, 23, 25 AND 50).

### **CLASS 8—HAND TOOLS**

FOR NON-ELECTRIC KNIVES, TABLE FORKS AND SPOONS, RAZORS, SILVER PLATED KNIVES, FORKS AND SPOONS, POCKET KNIVES, PENKNIVES, HUNTING KNIVES, SCISSORS; PRUNING SCISSORS, FLOWER CUTTERS, MANICURE AND PEDICURE SETS, PLIERS, SUGAR TONGS (U.S. CLS. 23, 28 AND 44).

### **CLASS 9—ELECTRICAL AND SCIENTIFIC APPARATUS**

FOR APPARATUS FOR RECORDING, TRANSMISSION OR REPRODUCTION OF SOUND OR IMAGES, NAMELY, DIGITAL RECORDERS AND MP3 PLAYERS; SPECTACLE CASES, SUNGLASSES, GOGGLES FOR SPORTS; SPECTACLES, BINOCULARS, CASES FOR BINOCULARS, TELESCOPES, PROTECTIVE HELMETS FOR SPORTS, RIDING HELMETS, USB KEY FOBS, ELECTRONIC AGENDAS, ELECTRONIC GAME SOFTWARE, MOUSE PADS, TEMPERATURE INDICATORS, GRADUATED RULERS, DIRECTIONAL COMPASSES, MAGNIFYING GLASSES, DOG WHISTLES, MOBILE PHONES; TELEPHONE STRAPS (U.S. CLS. 21, 23, 26, 36 AND 38).

### **CLASS 11—ENVIRONMENTAL CONTROL APPARATUS**

FOR FIXTURES FOR INCANDESCENT LIGHT BULBS, LED LIGHTING FIXTURES, LAMPS, ELECTRIC LAMPS, CHANDELIERS, STREET LAMPS, FLASHLIGHTS, LIGHTS FOR BICYCLES AND VEHICLES, LAMP SHADES, NIGHT LIGHTS, CEILING LIGHTS, TAPS (U.S. CLS. 13, 21, 23, 31 AND 34).

### **CLASS 12—VEHICLES**

FOR BICYCLES AND PUSHCHAIRS (U.S. CLS. 19, 21, 23, 31, 35 AND 44).

### **CLASS 14—JEWELRY**

FOR PRECIOUS STONES; JEWELRY PRODUCTS, NAMELY, NECKLACES, BRACELETS, RINGS, EARRINGS, PENDANTS, BROOCHES, BADGES OF PRECIOUS METAL, CUFFLINKS, MEDALS, MEDALLIONS, CHARMS, TIE CLIPS, TIE PINS AND CHAINS; BOXES IN PRECIOUS METAL, JEWELRY CASES; HOROLOGICAL AND CHRONOMETRIC INSTRUMENTS, NAMELY, WATCHES AND THEIR COMPONENT PARTS, WRIST-WATCHES, CLOCKS, SMALL CLOCKS; CHRONOGRAPHS FOR USE AS TIMEPIECES, CHRONOMETERS, WATCH BANDS, WATCH CLASPS, CLOCK DIALS, WATCH CASES, WATCH CHAINS, MOVEMENTS FOR CLOCKS AND WATCHES, CASES FOR CLOCK AND WATCH-MAKING, JEWELRY CASES, CASES FOR WATCHES, KEY RINGS OF PRECIOUS METAL; SCARF RINGS; POUCHES AND BOXES FOR JEWELRY AND WATCHES NOT OF PRECIOUS METAL (U.S. CLS. 2, 27, 28 AND 50).

### **CLASS 15—MUSICAL INSTRUMENTS**

FOR MUSIC BOXES (U.S. CLS. 2, 21 AND 36).

### **CLASS 16—PAPER GOODS AND PRINTED MATTER**

FOR PAPER, CARDBOARD, NAMELY, BOXES; BAGS AND SACKS, NAMELY, PAPER BAGS AND PAPER AND CARDBOARD SACKS; ENVELOPES; PAPER POUCHES FOR PACKAGING; WRAPPING PAPER, PHOTOGRAPH ALBUMS AND SCRAPBOOK ALBUMS, STATIONERY WRITING PAPERS AND ENVELOPES, DOCUMENT FILES, AGENDAS, ALMANACS, TEAR-OFF CALENDARS, STATIONERY PADS, DRAWING PADS, WRITING PAPER, WRITING BOOKS, CALENDARS, NOTE BOOKS, FILE FOLDERS; PENCIL LEAD HOLDERS, PENCIL LEADS, PENCILS, PENCIL HOLDERS, FOUNTAIN PENS, FELT-TIP PENS, PENHOLDERS, DRAWING PENS, PEN NIBS, PEN CASES, PASTEL CRAYONS, PENCIL CASES; DRAWING SETS, COMPRISED OF PAPER, PENCILS, PADS, PENS; PENCIL CUPS, ANNOUNCEMENT CARDS, INDEX CARDS, GLUES FOR STATIONERY OR HOUSEHOLD PURPOSES; ARTISTS' MATERIALS, NAMELY, PAINT BRUSHES, PAINTING SETS FOR CHILDREN, PAINT TRAYS, ARTS AND CRAFT PAINT KITS, ARTS AND CRAFT CLAY KITS, CHALK, MOULDS FOR MODELING CLAYS, PAINTERS' EASELS, CANVAS FOR PAINTING, PALETTES FOR PAINTERS, PAINT BOXES FOR SCHOOL PURPOSES, DRAWINGS, DRAWING INSTRUMENTS, PAPER-CLIPS; INSTRUCTIONAL AND TEACHING MATERIAL, NAMELY, BOOKS AND PAMPHLETS IN THE FIELD OF WEARING APPAREL, SHOES, HANDBAGS, WATCHES, PERFUME, LEATHER ACCESSORIES, HOME FURNISHINGS, SADDLERY AND CULTURAL EVENTS; PLASTICS FOR PACKAGING NOT INCLUDED IN OTHER CLASSES, NAMELY, BAGS AND SACKS FOR PACKAGING PURPOSES; PLASTIC FILM NOT FOR COMMERCIAL OR INDUSTRIAL PURPOSES; PLASTIC SHEETS FOR WRITING, PRINTING AND MARKING, CHECK-BOOK HOLDERS, EMBROIDERY DESIGN PATTERNS, GRAPHIC ART REPRODUCTIONS, PHOTOGRAPHS, PHOTOGRAPH STANDS, ENGRAVINGS, PHOTO-ENGRAVINGS, PICTURES, PORTRAITS, POSTERS; LITHOGRAPHS; BOOKLETS, MANUALS, CATALOGUES, PAMPHLETS, PERIODICALS, MAGAZINES IN THE FIELD OF WEARING APPAREL, SHOES, HANDBAGS, WATCHES, PERFUME, LEATHER ACCESSORIES, HOME FURNISHINGS, SADDLERY AND CULTURAL EVENTS; POSTAL CARDS, MUSICAL GREETING CARDS, MONEY CLIPS, PAPER KNIVES, TABLE LINEN OF PAPER, TABLE-CLOTHS OF PAPER, TABLE NAPKINS OF PAPER, PLACE MATS OF PAPER, TABLE MATS OF PAPER, COASTERS OF PAPER, BIBS OF PAPER, HANDKERCHIEFS OF PAPER, FLOWER-POT COVERS OF PAPER, BOOKENDS, BOOKMARKERS, PASSPORT HOLDERS, WRITING PADS, HAT BOXES OF CARDBOARD; COVER BOOKS IN THE NATURE OF BOOK COVERS; LETTER

TRAYS; ENGRAVED WORKS OF ART IN THE NATURE OF PRINT ENGRAVINGS; LITHOGRAPHIC WORKS OF ART, ATLASES; CARDBOARD ARTICLES, NAMELY, BOXES, BAGS AND POUCHES FOR PACKAGING PURPOSES; FOLDERS FOR PAPER, CHROMOLITHOGRAPHS, PATTERNS FOR MAKING CLOTHES, FLAGS OF PAPER, DRAWING SHIELDS; WRITING MATERIALS, NAMELY, PAPER AND PENS; WRITING INSTRUMENTS, PLACARDS OF PAPER OR CARDBOARD; LABELS NOT OF TEXTILE, NAMELY, PAPER LABELS; PAPER BOWS FOR WRAPPING, PAPERWEIGHTS, ENGRAVING PLATES, DRAWING BOARDS, BLUEPRINTS, STENCIL PLATES, DRAWING RULERS, COLORING BOOKS, RUBBER ERASERS, BIRTH BOOKS, STICKERS; AGENDA COVERS (U.S. CLS. 2, 5, 22, 23, 29, 37, 38 AND 50).

### CLASS 18—LEATHER GOODS

FOR LEATHER AND IMITATIONS OF LEATHER, AND GOODS MADE OF THESE MATERIALS, NAMELY, HANDBAGS, TRAVELLING BAGS, RUCKSACKS, SCHOOL SATCHELS AND SCHOOL BAGS, BEACH BAGS; SHOPPING BAGS MADE OF CANVAS, LEATHER AND TEXTILE; GARMENT TRAVEL BAGS, BAGS FOR SPORT, CHANGING BAGS FOR BABIES, RETICULES, WHEELED BAGS, SLING BAGS FOR CARRYING CHILDREN, POCKET WALLETS, PURSES IN LEATHER, CREDIT CARD CASES, BUSINESS CARD CASES, ATTACHÉ CASES, BRIEFCASES, KEY CASES IN LEATHER, TRUNKS AND SUITCASES, TRAVELLING TRUNKS, TOILETRY BAGS SOLD EMPTY, LEATHER SACKS AND POUCHES, SADDLERY, SADDLE TREES, BRIDLES, BRIDOOONS, LEATHER STRAPS FOR SADDLERY PURPOSES, REINS, HORSESHOES, COLLARS FOR HORSES, STIRRUPS, PARTS OF RUBBER FOR STIRRUPS, STIRRUP LEATHERS, HARNESS FOR HORSE, HORSE HALTERS, FASTENINGS FOR SADDLES, BANDS OF LEATHER, STRAP SHOULDER BELTS OF LEATHER, KNEE-PADS FOR HORSES, HORSE BLINKERS, HORSE BLANKETS, COVERS FOR HORSE SADDLES, PADS FOR HORSE SADDLES, WHIPS, CAT O' NINE TAILS, BOXES SPECIALLY ADAPTED FOR HORSE SADDLES, SADDLES FOR HORSES, BITS FOR ANIMALS, HARNESS FITTINGS, BOXES IN LEATHER OR IN LEATHER BOARD, HAT BOXES IN LEATHER, PARASOLS, UMBRELLAS, UMBRELLA RINGS, UMBRELLA COVERS, WALKING STICKS, SUITCASE HANDLES, COLLARS FOR ANIMALS, LEASHES FOR ANIMALS, MUZZLES, COATS FOR ANIMALS, ANIMAL BAGS IN THE NATURE OF FEED BAGS FOR ANIMALS, BAGS MADE OF ANIMAL SKIN; ANIMAL HARNESES, ANIMAL SKINS, CARRY-ALL BAGS FOR CAMPERS, LEATHER ANIMAL LEASHES, DECORATIVE TWISTS OF LEATHER FOR TRIMMING GOODS MADE OF LEATHER; TRIMMINGS OF LEATHER FOR FURNITURE, HUNTING GAME BAGS; BAGS IN THE NATURE OF ENVELOPES AND POUCHES OF LEATHER FOR PACKAGING; UNFITTED VANITY CASE MADE OF TEXTILE; CHANGING BAGS FOR BABIES MADE OF TEXTILE; UNFITTED FURNITURE COVERING OF LEATHER; SMALL BOXES OF LEATHER FOR STORAGE OF PINS AND COINS; SHAVING CASES SOLD EMPTY (U.S. CLS. 1, 2, 3, 22 AND 41).

### CLASS 20—FURNITURE AND ARTICLES NOT OTHERWISE CLASSIFIED

FOR FURNITURE, PICTURE FRAMES, MOLDINGS FOR PICTURE FRAMES; CHESTS FOR TOYS, NON-METAL BINS, CUSHIONS, DECORATIVE MOBILES, WIND CHIMES, MATTRESSES, PET CUSHIONS, BEDS FOR HOUSEHOLD PETS, BOXES AND CASES OF WOOD AND PLASTIC; CORKS FOR BOTTLES, BOTTLE CAPS NOT OF METAL; HIGH CHAIRS FOR BABIES, PLAYPENS FOR BABIES, MATS FOR INFANT PLAYPENS, COTS, COAT HANGERS, KNIFE HANDLES NOT OF METAL, MIRRORS, HANDHELD MIRRORS, SILVERED GLASS FOR USE AS A MIRROR; FURNITURE, TABLE TOPS, UMBRELLA STANDS, BOOK RESTS, MAGAZINE RACKS, HAT STANDS, SEATS, EASY CHAIRS, ARMCHAIRS, SETTEES, DIVANS, FOOTSTOOLS, SOFAS, FURNITURE IN THE NATURE OF POUFS, FURNITURE HEAD-RESTS, BEDS, CUPBOARDS, BENCHES, SCREENS, DOORS FOR FURNITURE, WRITING DESKS, PLATE RACKS, FURNITURE

IN THE NATURE OF SHOWCASES, LIBRARY SHELVES, COAT STANDS, BEDSTEADS OF WOOD, FURNITURE PARTITIONS OF WOOD, SIDEBOARDS, DINNER WAGONS, INDEX CABINETS, TABLES, DRESSING TABLES, CHESTS OF DRAWERS, DESKS; WORKS OF ART OF WOOD, WAX, PLASTER AND PLASTIC; BUSTS, FIGURINES AND STATUES OF WOOD, WAX, PLASTER AND PLASTIC; COSTUME STANDS, EMBROIDERY FRAMES, KEY BOARDS FOR HANGING KEYS; COAT HOOKS NOT OF METAL, CLOTHES HOOKS NOT OF METAL, DISPLAY BOARDS, NON-ELECTRIC FANS FOR PERSONAL USE, FURNITURE AND DOOR KNOBS NOT OF METAL; NEWSPAPER DISPLAY STANDS, LETTER BOXES NOT OF METAL OR MASONRY, DOOR HANDLES NOT OF METAL, DISPLAY STANDS, INDOOR WINDOW BLINDS; WICKERWORK, NAMELY, CHAIRS, TABLES AND BOXES; BOTTLE RACKS; TEXTILE WINDOW BLINDS; SLEEPING BAGS; PLASTIC FLAGS; FITTED FURNITURE COVERING OF LEATHER (U.S. CLS. 2, 13, 22, 25, 32 AND 50).

### CLASS 21—HOUSEWARES AND GLASS

FOR COMBS, CLEANING SPONGES, COMB AND BRUSH CASES; BRUSHES, NAMELY, HAIR BRUSHES, BATH BRUSHES, COSMETIC BRUSHES, CLOTHES BRUSHES; BRUSH-MAKING MATERIALS; UNWORKED OR SEMI-WORKED GLASS, EXCEPT GLASS USED IN BUILDING; GLASSWARE FOR TABLE USE, NAMELY, DRINKING GLASSES, GOBLETTS AND CARAFES; TABLEWARE, NAMELY, DISHES, PLATES, BOWLS, VEGETABLE DISHES, TEACUPS, COFFEE CUPS, SALAD BOWLS, SOUP BOWLS, SAUCERS, SUGAR BOWLS, EGG CUPS AND FRUIT BOWLS; PORCELAIN WARE FOR TABLE USE, NAMELY, BOWLS AND PLATES; EARTHENWARE FOR TABLE USE, NAMELY, BOWLS AND PLATES; INSULATED BAGS FOR FOOD OR BEVERAGE OR DOMESTIC USE; TOILET BRUSHES, TOILET SPONGES; TOILET CASES, NAMELY, FITTED VANITY CASES; UTENSILS FOR TOILET PURPOSES, NAMELY, HAIR BRUSHES, TOOTHBRUSHES, NAIL BRUSHES AND COMBS; UTENSILS FOR COSMETIC PURPOSES, NAMELY, HAIR BRUSHES, TOOTHBRUSHES, NAIL BRUSHES AND COMBS; FLOWER-POT COVERS NOT OF PAPER, JUGS, DEMIJOHNS, CANDY BOXES, ICE BUCKETS, EPERGNES, CUPS, COFFEEPOTS AND TEAPOTS NON-ELECTRIC; DRINKING GLASSES IN THE NATURE OF TUMBLERS; DISH COVERS, CUPS, CHOPSTICKS, BUTTER DISHES, NON-ELECTRIC HEATERS FOR FEEDING BOTTLES, COOKIE JARS, SOAP BOXES, TEA AND COFFEE CADDIES, BOXES OF METAL FOR DISPENSING PAPER TOWELS, BOXES OF GLASS, GLASS STOPPERS, CORKSCREWS, NON-ELECTRIC CANDELABRA, BOTTLES SOLD EMPTY, BOTTLE OPENERS, DOORKNOBS OF PORCELAIN, PERFUME BURNERS, COASTERS NOT OF PAPER AND OTHER THAN TABLE LINEN, MENU CARD HOLDERS, FOOD BASKETS FOR DOMESTIC USE, KNIFE RESTS FOR THE TABLE, CRYSTAL DRINKING GLASSES AND BOWLS, MIXING SPOONS, TOOTHPICK HOLDERS, TRIVETS, SPICE RACKS, SPONGE HOLDERS; WORKS OF ART OF PORCELAIN, TERRACOTTA AND GLASS; BUSTS, FIGURINES AND STATUES OF PORCELAIN, TERRA-COTTA AND GLASS; FLOWER POTS, HOLDERS FOR FLOWERS AND PLANTS, GARDENING GLOVES, PORTABLE NON-ELECTRIC COLD BOXES; VEGETABLE DISHES, NAMELY, SERVING PLATTERS; LIQUEUR SETS, NAMELY, DRINKING GLASSES AND ICE BUCKETS; MOSAIC OF GLASS, NOT FOR BUILDING; FITTED PICNIC BASKETS INCLUDING DISHES; FLASKS, PERFUME VAPORIZERS SOLD EMPTY; PIE SERVERS, TRAYS FOR DOMESTIC PURPOSES, PEPPER POTS, SALT CELLARS, SOAP HOLDERS, NAPKIN HOLDERS, TOWEL RAILS AND RINGS; POTS, POT LIDS, POWDER COMPACTS, NAPKIN RINGS, VASES; ANIMAL COMBS, FEEDING TROUGHES FOR ANIMALS, CURRY COMBS; SHOE HORNS BRUSHES FOR FOOTWEAR, SHOE TREES; PIGGY BANKS, NOT OF METAL; HEAT-INSULATED CONTAINERS FOR FOOD OR BEVERAGE FOR DOMESTIC USE, INSULATING FLASKS, REFRIGERATING BOTTLES; MANUAL MIXERS IN THE NATURE OF COCKTAIL SHAKERS; SMALL TRAYS MADE OF TEXTILE FOR CONTAINING PINS AND COINS; TRAYS NOT OF METAL; SMALL LEATHER TRAYS FOR PINS AND COINS; BRUSHES FOR HORSES; WICKER BASKETS FOR DOMESTIC USE (U.S. CLS. 2, 13, 23, 29, 30, 33, 40 AND 50).

**CLASS 24—FABRICS**

FOR SILK CLOTHS; WOVEN, NON-WOVEN OR KNITTED FABRICS FOR THE MANUFACTURE OF CLOTHING; BED AND TABLE BLANKETS, CURTAINS MADE OF TEXTILE OR MADE OF PLASTIC; HOUSEHOLD LINEN, FABRIC TABLE RUNNERS, COVERS FOR CUSHIONS, BEDSPREADS, BED LINEN, BED SHEETS, BATH SHEETS, FACE TOWELS, WASHING MITTS, GUEST TOWELS, TABLE LINEN NOT OF PAPER, TABLE NAPKINS OF TEXTILE, PLACE MATS NOT MADE OF PAPER, HANDKERCHIEFS MADE OF TEXTILE; LABELS OF CLOTH, BOXES MADE OF TEXTILE, UPHOLSTERY FABRICS, TRACED CLOTHS FOR EMBROIDERY, CLOTH COASTERS, FABRIC FOR BOOTS AND SHOES, TRAVELLING RUGS, BED COVERS; LININGS, NAMELY, TEXTILE USED AS LINING FOR CLOTHING, LINEN LINING FABRIC FOR SHOES; CLOTH FLAGS, LINGERIE FABRIC; TAPESTRY MADE OF TEXTILE, TABLECLOTHS NOT OF PAPER, TABLEMATS NOT OF PAPER, THROWS; BAGS SPECIALLY ADAPTED FOR TRAVELLING RUGS; MOLE SKIN; SMALL BOXES OF TEXTILE FOR STORAGE OF PINS AND COINS; COVERS OF TEXTILE FOR STORING CLOTHING, NAMELY, SUITS AND DRESSES (U.S. CLS. 42 AND 50).

**CLASS 25—CLOTHING**

FOR PAJAMAS, DRESSING GOWNS, NIGHTDRESSES, SHORTS, TANK TOPS, JEANS, SWEATSHIRTS, JUMPSUITS, SWIMWEAR, HOSIERY, LAYETTES, PAREOS, APRONS, PANTS, BATHING TRUNKS, BATHING SUITS, OVERALLS, BOAS, TEDDIES, PULLOVERS, SWEATERS, WAISTCOATS, SHIRTS, SHIRT YOKES, SHIRT FRONTS, JUMPERS, COLLARS; UNDERWEAR, BREECHES FOR WEAR, UNDERPANTS, SARIS, T-SHIRTS, TROUSERS, JACKETS, SUITS, UNIFORMS, COATS; WATERPROOF JACKETS AND PANTS, OVERCOATS, PARKAS, SKIRTS, DRESSES, BOOTS, HALF-BOOTS, ESPARTO SHOES, BEACH SHOES, WOODEN SHOES, SPORT SHOES, SLIPPERS, SHOES, BATH SANDALS, BOOT UPPERS, HATS, CAPS, TOP HATS, GLOVES, MITTENS, TIES, BELTS, MONEY BELTS, SCARVES, ASCOTS, POCKET SQUARES, SASHES, SHAWLS, STOCKINGS, SOCKS, TIGHTS, SUSPENDERS, BIBS NOT OF PAPER, HEADBANDS, FUR STOLE; FURS, NAMELY, STOLE (U.S. CLS. 22 AND 39).

**CLASS 26—FANCY GOODS**

FOR BUTTONS, ARTIFICIAL FLOWERS, SHOE FASTENERS; FASTENINGS FOR CLOTHING IN THE NATURE OF EYELETS, BUTTONS, HOOKS; SEWING BOXES, CLOTHING BUCKLES, SHOE BUCKLES, SNAP FASTENERS, FASTENINGS FOR SUSPENDERS, CLOTHING BROOCHES, BELT CLASPS, HAT ORNAMENTS NOT OF PRECIOUS METAL, SHOE HOOKS, SHOE EYELETS, SHOE ORNAMENTS NOT OF PRECIOUS METAL, HAIR ORNAMENTS, HAIR PINS, BARRETTES, ZIP FASTENERS, SLIDE LOCK FASTENERS FOR BAGS; FITTINGS OF METAL FOR SHOES AND BOOTS, NAMELY, BUCKLES, EYELETS AND ORNAMENTS NOT OF PRECIOUS METAL (U.S. CLS. 37, 39, 40, 42 AND 50).

**CLASS 28—TOYS AND SPORTING GOODS**

FOR DECORATIONS FOR CHRISTMAS TREES, PLAYING CARDS, PLAYING CARD CASES AND BOXES, MATS FOR POKER TABLES, PLAY MATS CONTAINING INFANT TOYS, PLAY MATS FOR USE WITH TOY VEHICLES, AND PUTTING PRACTICE MATS, BOARD GAMES, COUNTERS FOR GAMES, CUPS FOR DICE, GAME DICE, TOY ROCKING HORSES, INFANT RATTLES, PLUSH TOYS, TEDDY BEARS, JIGSAW PUZZLES, PARLOR GAMES, BALLS FOR GAMES, PLAY BALLOONS, MUSICAL TOY MOBILES AND TOY MOBILES, BUILDING GAMES, DARTS, DART BOARDS, DOMINOES, CHESS GAMES, CHESSBOARDS, GOLF GLOVES AND BATTING GLOVES, GOLF GLOVES, GOLF BAGS WITH OR WITHOUT WHEELS, GOLF CLUBS, BAGS SPECIALLY ADAPTED FOR SPORT RACKETS, PET TOYS, DOLLS, DOLLS' CLOTHES, DOLLS' HOUSES, PUPPETS, TOY VEHICLES, CHILD ACTIVITY MATS (U.S. CLS. 22, 23, 38 AND 50).

**CLASS 34—SMOKERS' ARTICLES**

FOR MATCHES, MATCH BOXES, CIGAR BOXES, CIGARETTE BOXES, LIGHTERS FOR SMOKERS, ASHTRAYS FOR SMOKERS, CIGAR AND CIGARETTE CASES, CIGAR CUTTERS, TOBACCO JARS, SNUFF BOXES NOT OF PRECIOUS METAL (U.S. CLS. 2, 8, 9 AND 17).

HEATHER BIDDULPH, EXAMINING ATTORNEY

SN 85-054,856. SALISBURY UNIVERSITY, SALISBURY, MD.  
FILED 6-4-2010.

A Maryland University of  
National Distinction

THE MARK CONSISTS OF STANDARD CHARACTERS WITHOUT CLAIM TO ANY PARTICULAR FONT, STYLE, SIZE, OR COLOR.

NO CLAIM IS MADE TO THE EXCLUSIVE RIGHT TO USE "A MARYLAND UNIVERSITY", APART FROM THE MARK AS SHOWN.

SEC. 2(F).

**CLASS 9—ELECTRICAL AND SCIENTIFIC APPARATUS**

FOR DOWNLOADABLE ELECTRONIC PUBLICATIONS IN THE NATURE OF CATALOGS, BROCHURES, NEWSLETTERS, MAGAZINES, NEWS ARTICLES AND RELEASES, AND PAPERS FEATURING SPEECHES AND STATEMENTS MADE BY UNIVERSITY EMPLOYEES, UNIVERSITY POLICIES, PROCEDURES AND PROGRAMS, AND ACADEMIC AND RESEARCH OFFERINGS AND ACTIVITIES ARISING OUT OF THE UNIVERSITY'S DIFFERENT ACADEMIC DEPARTMENTS (U.S. CLS. 21, 23, 26, 36 AND 38).

FIRST USE 1-1-2006; IN COMMERCE 1-1-2006.

**CLASS 16—PAPER GOODS AND PRINTED MATTER**

FOR SCHOLARLY PAPERS AND PUBLICATIONS IN THE NATURE OF CATALOGS, BROCHURES, NEWSLETTERS, MAGAZINES, NEWS ARTICLES AND RELEASES, AND PAPERS RELATED TO ACADEMIC AND RESEARCH OFFERINGS AND ACTIVITIES IN ACADEMIC FIELDS OF ARTS AND HUMANITIES, BEHAVIORAL AND SOCIAL SCIENCES, BUSINESS, COMPUTER, MATHEMATICAL AND PHYSICAL SCIENCES, EDUCATION, ENGINEERING, HEALTH AND HUMAN PERFORMANCE, COMMUNICATION, COMMUNITY STUDIES AND CIVIC ENGAGEMENT, LIBRARY AND INFORMATION SERVICES, LIFE SCIENCES, ENVIRONMENTAL STUDIES, SIMULATION AND DIGITAL ENTERTAINMENT, AND PUBLIC AFFAIRS; UNIVERSITY STATIONERY, MAGAZINES, CATALOGS AND PAMPHLETS DESCRIBING THE UNIVERSITY'S EDUCATIONAL AND RESEARCH SERVICES; UNIVERSITY POSTCARDS, DECALS, ADDRESS LABELS, ANNOUNCEMENT AND NOTE CARDS; GRAPHIC ART REPRODUCTIONS; PRINTED AWARDS; PAPER NAME BADGES; PLASTIC AND PAPER MERCHANDISE BAGS; PAPER BANNERS; DESK ACCESSORIES, NAMELY, DESK BLOTTERS, PENCIL HOLDERS, PAPER-WEIGHT AND PAPER CLIP HOLDERS AND STATIONERY NOTE PAD HOLDERS; LOOSE LEAF BINDER SETS; BOOK COVERS; BULLETINS CONCERNING UNIVERSITY EVENTS AND POLICIES; BUMPER STICKERS; CHRISTMAS CARDS; PRINTED INSTRUCTIONAL, EDUCATIONAL AND TEACHING MATERIALS, NAMELY, COURSE MATERIALS IN THE FIELDS OF ARTS AND HUMANITIES, BEHAVIORAL AND SOCIAL SCIENCES, BUSINESS, COMPUTER, MATHEMATICAL AND PHYSICAL SCIENCES, EDUCATION, ENGINEERING, HEALTH AND HUMAN PERFORMANCE, COMMUNICATION, COMMUNITY STUDIES AND CIVIC ENGAGEMENT, LIBRARY AND INFORMATION SERVICES, LIFE SCIENCES, ENVIRONMENTAL STUDIES, SIMULATION AND DIGITAL ENTERTAINMENT, AND PUBLIC AFFAIRS; TELEPHONE DIRECTORIES (U.S. CLS. 2, 5, 22, 23, 29, 37, 38 AND 50).

FIRST USE 1-1-2006; IN COMMERCE 1-1-2006.

**CLASS 25—CLOTHING**

FOR T-SHIRTS, SWEAT SHIRTS, SWEAT PANTS, GYM SHORTS, ATHLETIC JACKETS AND UNIFORMS, WIND RESISTANT JACKETS, BASEBALL CAPS, SWEAT BANDS, INFANT WEAR, NECKTIES (U.S. CLS. 22 AND 39).

FIRST USE 1-1-2006; IN COMMERCE 1-1-2006.

**CLASS 28—TOYS AND SPORTING GOODS**

FOR TOYS, NAMELY, BASKETBALLS, FOOTBALLS, GOLF BALLS, STUFFED TOY ANIMALS (U.S. CLS. 22, 23, 38 AND 50).

FIRST USE 1-1-2006; IN COMMERCE 1-1-2006.

**CLASS 41—EDUCATION AND ENTERTAINMENT**

FOR EDUCATIONAL SERVICES, NAMELY, DEVELOPING, ARRANGING FOR AND PROVIDING COURSES OF INSTRUCTION AT THE UNDERGRADUATE, GRADUATE AND POSTGRADUATE UNIVERSITY LEVELS; EXTENSION, CONTINUING AND COMMUNITY EDUCATION SERVICES, NAMELY, PROVIDING LIVE AND ON-LINE CONTINUING EDUCATION SEMINARS IN THE LEGAL, BUSINESS, ARTS, SCIENCES AND PUBLIC AFFAIRS FIELDS; DEVELOPING AND ARRANGING FOR AND PROVIDING SEMINARS, CONFERENCES AND WORKSHOPS IN THE FIELDS OF AGRICULTURE AND NATURAL RESOURCES, ARCHITECTURE, ARTS AND HUMANITIES, BEHAVIORAL AND SOCIAL SCIENCES, BUSINESS, COMPUTER, MATHEMATICAL AND PHYSICAL SCIENCES, EDUCATION, ENGINEERING, HEALTH AND HUMAN PERFORMANCE, JOURNALISM, LIBRARY AND INFORMATION SERVICES, LIFE SCIENCES, AND PUBLIC AFFAIRS; DISTRIBUTING COURSE, SEMINAR, CONFERENCE AND WORKSHOP MATERIALS IN CONNECTION WITH THE FIELDS OF AGRICULTURE AND

NATURAL RESOURCES, ARCHITECTURE, ARTS AND HUMANITIES, BEHAVIORAL AND SOCIAL SCIENCES, BUSINESS, COMPUTER, MATHEMATICAL AND PHYSICAL SCIENCES, EDUCATION, ENGINEERING, HEALTH AND HUMAN PERFORMANCE, JOURNALISM, LIBRARY AND INFORMATION SERVICES, LIFE SCIENCES, AND PUBLIC AFFAIRS; DEVELOPING EDUCATIONAL MANUALS FOR OTHERS IN THE FIELDS OF AGRICULTURE AND NATURAL RESOURCES, ARCHITECTURE, ARTS AND HUMANITIES, BEHAVIORAL AND SOCIAL SCIENCES, BUSINESS, COMPUTER, MATHEMATICAL AND PHYSICAL SCIENCES, EDUCATION, ENGINEERING, HEALTH AND HUMAN PERFORMANCE, JOURNALISM, LIBRARY AND INFORMATION SERVICES, LIFE SCIENCES, AND PUBLIC AFFAIRS; CONDUCTING EDUCATIONAL DEMONSTRATIONS, RESEARCH AND TESTING; ISSUING AWARDS AND/OR DEGREES TO PERSONS WHO DEMONSTRATE EXCELLENCE IN ACADEMIC AND RESEARCH ENDEAVORS; ORGANIZING AND OFFERING EDUCATIONAL, CULTURAL, SPORTING EVENTS AND ENTERTAINMENT PROGRAMS, PERFORMANCES AND EXHIBITIONS IN THE NATURE OF ART EXHIBITS, THEATRICAL PERFORMANCES, MUSICAL PERFORMANCES IN THE FORM OF OPERAS, MUSICALS, ORCHESTRAL, BAND, JAZZ AND STRING ENSEMBLES, LECTURES ON ISSUES AND TOPICS RELATED TO THE FIELDS OF AGRICULTURE AND NATURAL RESOURCES, ARCHITECTURE, ARTS AND HUMANITIES, BEHAVIORAL AND SOCIAL SCIENCES, BUSINESS, COMPUTER, MATHEMATICAL AND PHYSICAL SCIENCES, EDUCATION, ENGINEERING, HEALTH AND HUMAN PERFORMANCE, JOURNALISM, LIBRARY AND INFORMATION SERVICES, LIFE SCIENCES, AND PUBLIC AFFAIRS; PUBLISHING AND DISTRIBUTING SCHOLARLY PUBLICATIONS, NAMELY, THESES, DISSERTATIONS, AND SCHOLARLY PAPERS, IN THE AFOREMENTIONED FIELDS (U.S. CLS. 100, 101 AND 107).

FIRST USE 1-1-2006; IN COMMERCE 1-1-2006.

GINA FINK, EXAMINING ATTORNEY

SN 85-055,824. JUBILANT ENPRO PVT. LTD, NOIDA, INDIA, FILED 6-7-2010.



PRIORITY CLAIMED UNDER SEC. 44(D) ON INDIA APPLICATION NO. 1896016, FILED 12-15-2009.

NO CLAIM IS MADE TO THE EXCLUSIVE RIGHT TO USE "ENERGY", APART FROM THE MARK AS SHOWN.

THE MARK CONSISTS OF THE PROFILE OF A BIRD FACING TO THE RIGHT AND CENTERED ABOVE THE WORD "JUBILANT" ALL ENCLOSED IN A TRAPEZOIDAL DESIGN IN WHICH THE TOP OF THE TRAPEZOID IS MADE UP OF TWO SLIGHTLY CURVED CONVEX ARCS WITH THE BOTTOM PORTION OF THE TRAPEZOID BEING CENTERED OVER AND OVERLAYING THE UPPER PORTION OF A RECTANGULAR SHAPE, WITH THE WORD "ENERGY" APPEARING BELOW THE TRAPEZOID WITHIN THE RECTANGULAR SHAPE.

**CLASS 35—ADVERTISING AND BUSINESS**

FOR BUSINESS MANAGEMENT SERVICES, NAMELY, OPERATION OF OIL AND NATURAL GAS PROCESSING AND COMPRESSION FACILITIES FOR OTHERS; BUSINESS MANAGEMENT SERVICES, NAMELY, OPERATION OF OIL AND NATURAL GAS DISTRIBUTION FACILITIES FOR OTHERS; TRANSPORTATION LOGISTICS SERVICES, NAMELY, ARRANGING THE TRANSPORTATION OF HYDROCARBONS FOR OTHERS; PROCUREMENT CONSULTING SERVICES, NAMELY, CONSULTING ABOUT PROCUREMENT OF CONTRACTS FOR OTHERS FOR THE PURCHASE OF ENERGY (U.S. CLS. 100, 101 AND 102).

**CLASS 37—CONSTRUCTION AND REPAIR**

FOR CONSTRUCTION SERVICES, NAMELY, DRILLING AND LAYING OF OIL AND NATURAL GAS PIPELINES; DRILLING OF OIL WELLS; CONSTRUCTION OF OIL AND NATURAL GAS PROCESSING AND COMPRESSION FACILITIES; CONSTRUCTION OF OIL AND NATURAL GAS DISTRIBUTION FACILITIES; AUTOMOBILE SERVICE STATION SERVICES FOR OIL CHANGES, ALIGNMENTS, GENERAL REPAIR AND MAINTENANCE; GENERAL CONSTRUCTION CONTRACTING AND CONSULTANCY SERVICES RELATED TO CONSTRUCTION, MAINTENANCE AND REPAIR OF ALL KINDS OF WORKS AND BUILDINGS; CONSTRUCTION PROJECT MANAGEMENT; BUILDING INSPECTION CONSULTING; AND MANAGEMENT OF CONSTRUCTION RELATING TO OIL AND NATURAL GAS EXPLORATION, EXTRACTION, COMPRESSION, REFINING AND DISTRIBUTION FACILITIES (U.S. CLS. 100, 103 AND 106).

**CLASS 39—TRANSPORTATION AND STORAGE**

FOR PROVIDING TRANSPORTATION OR TRANSMISSION OF NATURAL GAS THROUGH PIPELINES; PROVIDING TRANSPORT FACILITIES IN THE NATURE OF VESSEL MOORING FACILITIES FOR OIL AND NATURAL GAS TANKER SHIPS; ELECTRICITY DISTRIBUTION, PUBLIC UTILITY SERVICES IN THE NATURE OF NATURAL GAS DISTRIBUTION (U.S. CLS. 100 AND 105).

**CLASS 40—MATERIAL TREATMENT**

FOR NATURAL GAS AND FUEL REFINING SERVICES, NAMELY, REFINING, TREATMENT AND PROCESSING OF OIL, NATURAL GAS AND FUEL; GENERATION OF ELECTRICITY; OIL PRODUCTION SERVICES; NATURAL GAS PRODUCTION IN THE NATURE OF NATURAL GAS LIQUEFACTION SERVICES (U.S. CLS. 100, 103 AND 106).

**CLASS 42—SCIENTIFIC AND COMPUTER SERVICES**

FOR CONSULTING ABOUT INSPECTION OF OIL FIELDS; TECHNICAL CONSULTANCY SERVICES RELATED TO SCIENTIFIC RESEARCH, ENGINEERING, TECHNICAL STUDIES AND DESIGN IN THE FIELDS OF OIL AND NATURAL GAS EXPLORATION, EXTRACTION, COMPRESSION, REFINING AND DISTRIBUTION FACILITIES; OIL AND NATURAL GAS EXPLORATION, EXPLORATION OF HYDROCARBONS, OIL AND NATURAL GAS WELL SURVEYING, OIL AND NATURAL GAS PROSPECTING, OIL AND NATURAL GAS WELL TESTING SERVICES, ANALYSIS FOR OIL AND NATURAL GAS FIELD EXPLOITATION, GEOLOGICAL, GEOPHYSICAL OR ANY OTHER KIND OF SURVEYS FOR EXPLORATION AND PROSPECTING FOR OIL AND NATURAL GAS (U.S. CLS. 100 AND 101).

NELSON SNYDER, EXAMINING ATTORNEY

SN 85-055,842. SURDHAR, GURCHARAN KAUR, BIRMINGHAM, UNITED KINGDOM, FILED 6-7-2010.

**Heba the Ho'opononoist**

THE MARK CONSISTS OF STANDARD CHARACTERS WITHOUT CLAIM TO ANY PARTICULAR FONT, STYLE, SIZE, OR COLOR.

PRIORITY CLAIMED UNDER SEC. 44(D) ON UNITED KINGDOM APPLICATION NO. 2546621, FILED 5-5-2010, REG. NO. 2546621, DATED 5-5-2010, EXPIRES 5-5-2020.

THE WORDING "HO'OPONOIST" HAS NO MEANING IN A FOREIGN LANGUAGE.

**CLASS 9—ELECTRICAL AND SCIENTIFIC APPARATUS**

FOR PHOTOGRAPHIC, CINEMATOGRAPHIC AND OPTICAL APPARATUS AND INSTRUMENTS, NAMELY, CAMERAS, GLASSES, SUN GLASSES; APPARATUS FOR RECORDING, TRANSMISSION OR REPRODUCTION OF SOUND OR IMAGES; MAGNETIC DATA CARRIERS, RECORDING DISCS; AUTOMATIC VENDING MACHINES AND MECHANISMS FOR COIN-OPERATED APPARATUS; CASH REGISTERS, CALCULATING MACHINES, DATA PROCESSING EQUIPMENT AND COMPUTERS; FIRE-EXTINGUISHING APPARATUS; COMPUTERS, COMPUTER HARDWARE; COMPUTER SOFTWARE FOR COMPUTER GAMES; PARTS AND FITTINGS FOR ALL OF THE PRECEDING GOODS; DOWNLOADABLE ELECTRONIC PUBLICATIONS IN THE FIELD OF SPORTS, GAMES, MOTION PICTURE FILMS, CARTOONS, AND CHILDREN'S STORIES; INTERACTIVE COMPUTER SOFTWARE FOR COMPUTER GAMES; COMPUTER PROGRAMS, NAMELY, SOFTWARE LINKING DIGITIZED VIDEO AND AUDIO MEDIA TO A GLOBAL COMPUTER INFORMATION NETWORK; ARCADE GAMES ADAPTED FOR USE WITH TELEVISION RECEIVERS ONLY; COMPUTER GAME PROGRAMS ON CD-ROM; VIDEO AND COMPUTER GAME PROGRAMS; INTERACTIVE COMPUTER GAME SOFTWARE; VIDEO GAME DISCS, CARTRIDGES AND CASSETTES; ELECTRONIC GAMES CONSOLES, NAMELY, COMPUTER GAME CONSOLES FOR USE WITH AN EXTERNAL DISPLAY SCREEN OR MONITOR; COMPUTER GAME CONSOLES FOR USE WITH COMPUTERS; DOWNLOADABLE AUDIO AND VIDEO RECORDINGS FEATURING MUSIC, COMEDY, DRAMA, ACTION, ADVENTURE AND/OR ANIMATION; DOWNLOADABLE DIGITAL MUSIC PROVIDED FROM THE INTERNET; DOWNLOADABLE DIGITAL MUSIC PROVIDED FROM MP3 INTERNET WEB SITES; MP3 PLAYERS; MOTION PICTURE FILMS FEATURING COMEDY, DRAMA, ACTION, ADVENTURE AND/OR ANIMATION, AND MOTION PICTURE FILMS FOR BROADCAST ON TELEVISION FEATURING COMEDY, DRAMA, ACTION, ADVENTURE AND/OR ANIMATION; PRE-RECORDED VINYL RECORDS, PRE-RECORDED AUDIO TAPES, PRE-RECORDED AUDIO-VIDEO TAPES, PRE-RECORDED AUDIO VIDEO CASSETTES, PRE-RECORDED AUDIO AND VIDEO DISCS, ALL FEATURING MUSIC, CARTOONS AND VIDEOS; DIGITAL VERSATILE DISCS FEATURING MUSIC, COMEDY, DRAMA, ACTION, ADVENTURE, AND/OR ANIMATION; STEREO HEADPHONES; BATTERIES; CORDLESS TELEPHONES; MOBILE TELEPHONES; PARTS AND ACCESSORIES FOR MOBILE TELEPHONES; MOBILE TELEPHONE COVERS NOT MADE OF PAPER; MOBILE TELEPHONE CASES; MOBILE TELEPHONE CASES MADE OF LEATHER OR IMITATIONS OF LEATHER; MOBILE TELEPHONE COVERS MADE OF CLOTH OR TEXTILE MATERIALS; TELEPHONE AND RADIO PAGERS; HAND-HELD CALCULATORS; HAND-HELD KARAOKE PLAYERS; SHORT MOTION PICTURE FILM CASSETTES FEATURING COMEDY, DRAMA, ACTION, ADVENTURE AND/OR ANIMATION TO BE USED WITH HAND-HELD VIEWERS OR PROJECTORS; AUDIO CASSETTE RECORDERS AND PLAYERS, VIDEO CASSETTE RECORDERS AND PLAYERS, COMPACT DISC PLAYERS, DIGITAL VER-

SATILE DISC RECORDERS AND PLAYERS, DIGITAL AUDIO TAPE RECORDERS AND PLAYERS, ELECTRONIC DIARIES; RADIOS; MOUSE PADS; EYEGLASSES, SUNGLASSES AND CASES THEREFORE; ENCODED MAGNETIC CARDS, MAGNETICALLY ENCODED PRE-PAID PHONE CALLING CARDS, MAGNETICALLY ENCODED CREDIT CARDS, CASH CARDS, MAGNETICALLY ENCODED DEBIT CARDS, AND MAGNETIC KEY CARDS; DECORATIVE MAGNETS; SWIMMING AIDS, NAMELY, ARM AND BODY FLOATS FOR RECREATIONAL USE; SWIM BOARDS; GLOBAL POSITIONING SYSTEMS; NAVIGATION APPARATUS FOR VEHICLES IN THE NATURE OF NON-BOARD COMPUTERS; AMUSEMENT APPARATUS ADAPTED FOR USE WITH AN EXTERNAL DISPLAY SCREEN OR MONITOR FOR USE IN ARCADES; ELECTRONIC HAND-HELD GAME UNITS; PARLOR-TYPE COMPUTER GAME PROGRAMS (U.S. CLS. 21, 23, 26, 36 AND 38).

#### **CLASS 16—PAPER GOODS AND PRINTED MATTER**

FOR PAPER; CARDBOARD; PRINTED MATTER, NAMELY, BOOKS, MAGAZINES, BOOKLETS, BROCHURES, NEWSPAPERS, POSTERS FEATURING CHILDREN'S STORIES, SPORTS, GAMES, MOTION PICTURES, CARTOONS; BOOKBINDING MATERIAL; PHOTOGRAPHS; STATIONERY, ADHESIVES FOR STATIONERY OR HOUSEHOLD PURPOSES; ARTISTS' MATERIALS, NAMELY, PAINTS, CANVAS FOR PAINTING, PAPER FOR PAINTING, CANVAS HOLDERS IN THE NATURE OF CANVAS PANELS; PAINT BRUSHES; TYPEWRITERS; OFFICE REQUISITES EXCEPT FURNITURE, NAMELY, STAPLERS, PAPER HOLE PUNCHES, SCISSORS, LETTER OPENERS; INSTRUCTIONAL AND TEACHING MATERIAL EXCEPT APPARATUS IN THE FIELD OF SCIENCE; PLASTIC MATERIALS FOR PACKAGING NOT INCLUDED IN OTHER CLASSES; PRINTERS' TYPE; PRINTING BLOCKS; PRINTED MATTER AND PAPER GOODS, NAMELY, BOOKS FEATURING CHARACTERS FROM ANIMATED, ACTION, ADVENTURE, COMEDY AND/OR DRAMA FEATURES, COMIC BOOKS, CHILDREN'S BOOKS, MAGAZINES FEATURING CHARACTERS FROM ANIMATED, ACTION ADVENTURE, COMEDY AND/OR DRAMA FEATURES, COLORING BOOKS, CHILDREN'S ACTIVITY BOOKS; STATIONERY, WRITING PAPER, ENVELOPES, NOTEBOOKS, DIARIES, NOTE CARDS; GREETING CARDS, TRADING CARDS; LITHOGRAPHS; PENS, PENCILS, PEN AND PENCIL CASES, ERASERS, CRAYONS, MARKERS, COLORED PENCILS, PAINTING SETS FOR CHILDREN, CHALK AND CHALKBOARDS; DECALS, HEAT TRANSFER PAPER; POSTERS; MOUNTED AND/OR UNMOUNTED PHOTOGRAPHS; BOOK COVERS, BOOK MARKS, CALENDARS, GIFT WRAPPING PAPER; PAPER PARTY DECORATIONS, NAMELY, PAPER NAPKINS, PAPER DOILIES, PAPER PLACE MATS, CREPE PAPER, INVITATION CARDS; PAPER TABLE CLOTHS, PAPER CAKE DECORATIONS; PRINTED TRANSFERS FOR EMBROIDERY OR FABRIC APPLIQUES; PRINTED PATTERNS FOR COSTUMES, PYJAMAS, SWEATSHIRTS AND T-SHIRTS; PAPER PARTY FAVORS IN THE NATURE OF CRACKERS AND NOISE-MAKERS (U.S. CLS. 2, 5, 22, 23, 29, 37, 38 AND 50).

#### **CLASS 25—CLOTHING**

FOR CLOTHING, NAMELY, UNDERWEAR, PYJAMAS, SHIRTS, T-SHIRTS, PANTS, JACKETS, COATS, TIES, SUITS; FOOTWEAR; HEADGEAR, NAMELY, HEADWEAR; MASQUERADE MASKS (U.S. CLS. 22 AND 39).

#### **CLASS 28—TOYS AND SPORTING GOODS**

FOR GAMES AND PLAYTHINGS, NAMELY, BOARD GAMES, CARD GAMES; GYMNAS TIC AND SPORTING ARTICLES NOT INCLUDED IN OTHER CLASSES, NAMELY, SPRINGBOARDS, RACKETS; DECORATIONS FOR CHRISTMAS TREES; TOYS AND SPORTING GOODS, NAMELY, ACTION FIGURES, COLLECTABLE TOY FIGURES AND SCALE MODEL VEHICLES, BUILDINGS, WOODEN TOY BUILDING BLOCKS, TOY BUILDING BRICKS, TOY BUILDINGS, ACTION FIGURES AND ACCESSORIES THEREFOR; PLUSH TOYS; BALLOONS; BATHTUB TOYS; RIDE-ON TOYS; PLAYING CARDS; EQUIPMENT SOLD AS A UNIT FOR PLAYING CARD GAMES; TOY VEHICLES; DOLLS; FLYING DISCS; STAND ALONE VIDEO OUTPUT GAME MACHINES; COIN OR COUNTER OPERATED ARCADE GAMES; PINBALL GAME MACHINES; GAME EQUIPMENT SOLD AS A UNIT FOR PLAYING A BOARD GAME, A CARD GAME, A MANIPULATIVE GAME, A PARLOR GAME, AN ACTION TYPE TARGET GAME; JIGSAW AND MANIPULATIVE PUZZLES; PAPER PARTY HATS; PAPER FACE MASKS; SKATEBOARDS; ICE SKATES; WATER SQUIRTING TOYS; BALLS, NAMELY, PLAYGROUND BALLS, SOCCER BALLS, BASEBALLS, BASKETBALLS; BASEBALL GLOVES; SURFBOARDS; SWIMMING AIDS, NAMELY, ARM FLOATS AND BODY FLOATS, BOTH FOR RECREATIONAL USE; KICKBOARD FLOTATION DEVICES FOR RECREATIONAL USE; SWIM BOARDS FOR RECREATIONAL USE; SWIM FINNS; TOY ZIP GUNS; TOY BAKEWARE AND TOY COOKWARE; TOY BANKS; TOY SNOW GLOBES; CHRISTMAS TREE ORNAMENTS; HEADGEAR, NAMELY, MASQUERADE MASKS (U.S. CLS. 22, 23, 38 AND 50).

#### **CLASS 41—EDUCATION AND ENTERTAINMENT**

FOR EDUCATION, NAMELY, PROVIDING SEMINARS, WORKSHOPS, TRAINING CLASSES, COURSES IN THE FIELDS OF SCIENCE; PROVIDING OF TRAINING IN THE FIELD OF SCIENCE; PRODUCTION AND DISTRIBUTION OF MOTION PICTURE FILMS, CABLE TELEVISION PROGRAMMES AND TELEVISION PROGRAMMES, RADIO SHOWS, STAGE PLAYS AND PERFORMANCES AND THEATRICAL PRODUCTIONS; SHOWING, LEASING AND RENTAL OF MOTION PICTURE FILMS; ICE-SKATING SHOWS, DANCES AND CABARETS; INTERNET SERVICES IN THE NATURE OF PROVIDING INFORMATION VIA A GLOBAL COMPUTER NETWORK IN THE FIELD OF ENTERTAINMENT RELATING SPECIFICALLY TO MUSIC, MOVIES, AND TELEVISION SERIES; PROVIDING GENERAL INTEREST NEWS, ENTERTAINMENT, AND EDUCATIONAL INFORMATION VIA A GLOBAL COMPUTER NETWORK OR THE INTERNET; PROVIDING INFORMATION FOR AND/OR ACTUAL ENTERTAINMENT VIA A GLOBAL COMPUTER NETWORK OR THE INTERNET IN THE NATURE OF LIVE-ACTION, COMEDY, DRAMA AND/OR ANIMATED TELEVISION PROGRAMS; PROVISION OF RECREATIONAL FACILITIES, MOVIE THEATRES, ARCADE CENTERS, AMUSEMENT AND THEME PARKS; PROVIDING TRAINING IN THE FIELD OF MAGIC; ENTERTAINMENT IN THE NATURE OF MAGIC SHOWS; EDUCATIONAL SERVICES, NAMELY, SEMINARS, COURSES, CLASSES, WORKSHOPS VIA TELEVISION, AUDIO AND VIDEO ENTERTAINMENT FEATURING SCIENCE; MOVIE STUDIOS; PUBLISHING SERVICES, NAMELY, BOOKS, MAGAZINES, BOOKLETS, NEWSPAPERS, COMIC BOOKS; PUBLISHING OF PRINTED MATTER, NAMELY, BOOKS, MAGAZINES, BOOKLETS, NEWSPAPERS, COMIC BOOKS; PUBLISHING OF STORIES IN BOOKS, MAGAZINES, COMIC BOOKS, CHILDREN'S BOOKS, AND ONLINE PUBLICATION OF BOOKS; BOOK PUBLISHING; PUBLICATION OF ELECTRONIC BOOKS ON-LINE; CONSULTATION AND INFORMATION SERVICES RELATING TO THE PUBLICATION OF BOOKS (U.S. CLS. 100, 101 AND 107).

MICHAEL WIENER, EXAMINING ATTORNEY



SN 85-056,752. CISCO TECHNOLOGY, INC., SAN JOSE, CA.  
FILED 6-7-2010.



THE MARK CONSISTS OF THE WORD "TOGETHER"  
WRITTEN IN STYLIZED SCRIPT FONT.

#### **CLASS 9—ELECTRICAL AND SCIENTIFIC APPARATUS**

FOR COMPUTER HARDWARE AND COMPUTER SOFTWARE, NAMELY, COMPUTER SOFTWARE FOR CUSTOMER SUPPORT, CUSTOMER SERVICE MANAGEMENT AND TECHNICAL SUPPORT; COMPUTER HARDWARE AND SOFTWARE FOR INTERCONNECTING, MANAGING, SECURING AND OPERATING LOCAL AND WIDE AREA NETWORKS AND TELEPHONY SYSTEMS; COMPUTER HARDWARE AND SOFTWARE FOR TRANSMITTING, SECURING, STORING, UP-LOADING, POSTING, DISPLAYING, TAGGING, EDITING, ORGANIZING AND PROCESSING DATA, AUDIO AND VIDEO; TELEPHONES; WIRELESS COMMUNICATIONS DEVICES, NAMELY, WIRELESS HARDWARE AND SOFTWARE FOR THE TRANSMISSION OF DATA, AUDIO, AND VIDEO; CALL PROCESSING SOFTWARE FOR THE TRANSMISSION OF DATA, VIDEO, AND AUDIO; DOWNLOADABLE ELECTRONIC INSTRUCTIONAL MATERIALS, NAMELY, MANUALS, GUIDES, TEST MATERIALS, AND MAGAZINES IN THE FIELD OF TECHNOLOGY; COMPUTER SOFTWARE FOR USE IN SOCIAL NETWORKING; ELECTRONIC DEVICES, NAMELY, HANDHELD COMPUTERS AND SOFTWARE FOR RECORDING, ORGANIZING, TRANSMITTING, STORING AND/OR REVIEWING VOICE, AUDIO, VIDEO, AND/OR DATA FILES; NETWORK ROUTERS; COMPUTER SWITCHES; COMPUTER NETWORK ADAPTERS; COMPUTER SERVERS; COMMUNICATIONS SERVERS; COMPUTER HARDWARE CONTAINING NETWORK SECURITY FUNCTIONALITY, INCLUDING FIREWALLS, DATA ENCRYPTION, AND/OR INTEROPERABILITY WITH NETWORK SECURITY PROTOCOLS; DIGITAL VIDEO RECORDERS; SET-TO-BOXES; HARDWARE AND OPERATING SOFTWARE FOR CONFERENCING SERVICES; CAMCORDERS (U.S. CLS. 21, 23, 26, 36 AND 38).

#### **CLASS 38—COMMUNICATION**

FOR TELECOMMUNICATIONS SERVICES, NAMELY, TRANSMISSION OF INFORMATION, VOICE, VIDEO AUDIO, DATA, DOCUMENTS, IMAGES AND SOFTWARE APPLICATIONS VIA THE INTERNET; TELECOMMUNICATION SERVICES, NAMELY, PROVIDING WEB-BASED CONFERENCING; TELECOMMUNICATION SERVICES, NAMELY, PROVIDING CONSUMERS WITH SECURE REMOTE ACCESS VIA THE INTERNET TO PRIVATE COMPUTER NETWORKS; TELECOMMUNICATIONS SERVICES, NAMELY, PROVIDING INTERNET ACCESS TO DATA OR DOCUMENTS STORED ELECTRONICALLY FOR REMOTE CONSULTATION ALLOWING REMOTE USERS TO ACCESS JOINTLY SHARED DOCUMENTS, DATA, CALENDARS, TASK LISTS, ADDRESS BOOKS AND DISCUSSION FORUMS; PROVIDING INFORMATION VIA LOCAL AND GLOBAL COMPUTER NETWORKS ABOUT TELECOMMUNICATIONS AND TELEPHONY SYSTEMS; BROADCASTING PROGRAMS VIA COMPUTER NETWORKS; PROVIDING TELECOMMUNICATIONS SERVICES, NAMELY, WEB CONFERENCING SERVICES; INTERNET TELEPHONY SERVICES (U.S. CLS. 100, 101 AND 104).

#### **CLASS 41—EDUCATION AND ENTERTAINMENT**

FOR PROVIDING OF TRAINING IN THE FIELDS OF TECHNOLOGY; EDUCATIONAL SERVICES, NAMELY, CONFERENCES, TRAINING COURSES, TESTING, WORKSHOPS, AND DISTRIBUTING COURSE MATERIALS IN CONNECTION THEREWITH, ALL IN THE FIELDS OF TECHNOLOGY (U.S. CLS. 100, 101 AND 107).

#### **CLASS 42—SCIENTIFIC AND COMPUTER SERVICES**

FOR DESIGN AND DEVELOPMENT OF COMPUTER HARDWARE AND SOFTWARE; ON-LINE SERVICES, NAMELY, PROVIDING TECHNICAL INFORMATION VIA COMPUTER NETWORKS IN THE FIELD OF COMPUTER HARDWARE AND SOFTWARE, NETWORKING, NAMELY, COMPUTER NETWORK DESIGNS AND TELECOMMUNICATIONS, TELEPHONY AND NETWORKING TECHNOLOGY; PROVIDING TECHNICAL CONSULTATION IN CONNECTION WITH COMPUTER HARDWARE, COMPUTER SOFTWARE, COMPUTER NETWORKING EQUIPMENT, TELECOMMUNICATIONS EQUIPMENT, IP TELEPHONY, COMPUTER NETWORK DESIGN, PROVIDING COMPUTER CONSULTATION SERVICES ABOUT COMPUTER STORAGE DESIGN, SECURITY OF COMPUTER NETWORKS, AND VOICE AND WIRELESS COMMUNICATIONS; APPLICATION SERVICE PROVIDER (ASP), NAMELY, HOSTING THE SOFTWARE APPLICATIONS OF OTHERS; COMPUTER CONSULTING SERVICES; COMPUTER NETWORK DESIGN FOR OTHERS (U.S. CLS. 100 AND 101).  
TASNEEM HUSSAIN, EXAMINING ATTORNEY

SN 85-057,178. SPINDRIFT CONSULTING UK LIMITED,  
HAMPSHIRE SP10 2EA, UNITED KINGDOM, FILED 6-8-2010.

#### **SPINDRIFT SITE BUILDER**

THE MARK CONSISTS OF STANDARD CHARACTERS WITHOUT CLAIM TO ANY PARTICULAR FONT, STYLE, SIZE, OR COLOR.

OWNER OF ERPN CMNTY TM OFC REG. NO. 008755472,  
DATED 6-11-2010, EXPIRES 12-14-2019.

NO CLAIM IS MADE TO THE EXCLUSIVE RIGHT TO USE "SITE BUILDER", APART FROM THE MARK AS SHOWN.

#### **CLASS 9—ELECTRICAL AND SCIENTIFIC APPARATUS**

FOR INTERNET SITE DEVELOPMENT SOFTWARE (U.S. CLS. 21, 23, 26, 36 AND 38).

#### **CLASS 42—SCIENTIFIC AND COMPUTER SERVICES**

FOR WEB SITE DESIGN, DEVELOPMENT AND MAINTENANCE; INSTALLATION AND MAINTENANCE OF COMPUTER SOFTWARE; CONSULTANCY SERVICES RELATING TO WEB SITE DESIGN, DEVELOPMENT AND MAINTENANCE, AND RELATING TO INSTALLATION AND MAINTENANCE OF COMPUTER SOFTWARE (U.S. CLS. 100 AND 101).

KEVON CHISOLM, EXAMINING ATTORNEY

SN 85-059,964. RADIANT LOGISTICS, INC., BELLEVUE, WA. FILED 6-10-2010.

## SHOPROCKET

THE MARK CONSISTS OF STANDARD CHARACTERS WITHOUT CLAIM TO ANY PARTICULAR FONT, STYLE, SIZE, OR COLOR.

### CLASS 36—INSURANCE AND FINANCIAL

FOR FINANCIAL SERVICES, NAMELY, ADMINISTRATION OF CREDIT CARD AND WIRE TRANSFER TRANSACTIONS FOR OTHERS TO FACILITATE THE PURCHASE OF GOODS FROM WEB-BASED MERCHANTS (U.S. CLS. 100, 101 AND 102).

### CLASS 39—TRANSPORTATION AND STORAGE

FOR DOMESTIC AND INTERNATIONAL FREIGHT FORWARDING, AND FREIGHT MANAGEMENT SERVICES, NAMELY, THE TRANSPORTATION AND DELIVERY OF FREIGHT BY AIR, ROAD, RAIL AND SEA; PACKING, CRATING AND WAREHOUSING ARTICLES IN CONNECTION WITH THEIR TRANSPORTATION (U.S. CLS. 100 AND 105).

DAVID MURRAY, EXAMINING ATTORNEY

SN 85-062,452. CREAM HOLDINGS LIMITED, LIVERPOOL, UNITED KINGDOM, FILED 6-14-2010.

## CREAMFIELDS

THE MARK CONSISTS OF STANDARD CHARACTERS WITHOUT CLAIM TO ANY PARTICULAR FONT, STYLE, SIZE, OR COLOR.

OWNER OF U.S. REG. NO. 2,796,467.

### CLASS 9—ELECTRICAL AND SCIENTIFIC APPARATUS

FOR MUSICAL SOUND RECORDINGS; VIDEO RECORDINGS, AUDIOTAPES, AUDIO AND VIDEO CASSETTES, COMPACT DISCS, PHONOGRAPH RECORDS; ALL FEATURING MUSIC; ELECTRONIC GAME PROGRAMS; APPARATUS FOR RECORDING, TRANSMISSION, REPRODUCTION OF SOUND OR IMAGES, PHOTOGRAPHIC AND CINEMATIC APPARATUS AND INSTRUMENTS, NAMELY, VIDEO CASSETTE RECORDERS AND DIGITAL VIDEO RECORDERS; VIDEO RECORDERS AND VIDEO REPRODUCING APPARATUS; VIDEO OUTPUT GAME MACHINES FOR USE WITH TELEVISIONS; ELECTRONIC AMUSEMENT APPARATUS ADAPTED FOR USE WITH TELEVISION RECEIVERS, SUNGLASSES, CASES FOR SUNGLASSES, COMPACT DISC PLAYERS, TAPE RECORDERS, RADIO RECEIVERS, AUDIO CASSETTE TAPE RECORDERS, DOWNLOADABLE ELECTRONIC PUBLICATIONS IN THE NATURE OF A MAGAZINE, CATALOGUE OR NEWSLETTER IN THE FIELD OF MUSIC, DANCE, ENTERTAINMENT OR FASHION; DIGITAL MUSIC DOWNLOADABLE FROM THE INTERNET, MODEMS (U.S. CLS. 21, 23, 26, 36 AND 38).

### CLASS 25—CLOTHING

FOR CLOTHING, NAMELY, BELTS, GLOVES, HOSIERY, JACKETS, DRESSES, SKIRTS, JUMPERS, KNITWEAR, NAMELY, JACKETS AND TOPS, COATS, TROUSERS, SHIRTS, T-SHIRTS, UNDERWEAR, FOOTWEAR AND HEADWEAR, VISORS, CAPS, SWIMSUITS, SHORTS, PANTS, SWIMSUIT COVERS, NAMELY, BEACH COVER-UPS, SOCKS AND HATS (U.S. CLS. 22 AND 39).

### CLASS 41—EDUCATION AND ENTERTAINMENT

FOR INFORMATION RELATING TO ENTERTAINMENT, MUSIC, OR DANCE PROVIDED ON-LINE FROM A COMPUTER DATABASE OR THE INTERNET; PROVIDING ON-LINE, NON-DOWNLOADABLE PUBLICATIONS IN THE NATURE OF A MAGAZINE, CATALOGUE OR NEWSLETTER IN THE FIELD OF MUSIC, DANCE, ENTERTAINMENT OR FASHION; PROVIDING AN INTERNET WEBSITE PORTAL IN THE FIELD OF MUSIC, DANCE, ENTERTAINMENT AND LEISURE SERVICES, NAMELY, NIGHTCLUBS, DISCOTHEQUES, DANCE CLUBS; PUBLISHING OF ELECTRONIC PUBLICATIONS; ARRANGING AND CONDUCTING OF CONFERENCES RELATING TO THE MUSIC, DANCE, FASHION OR THE ENTERTAINMENT INDUSTRY FOR NON-BUSINESS AND NON-COMMERCIAL PURPOSES; DISTRIBUTION OF MOTION PICTURE FILMS, PRODUCTION OF FILMS AND VIDEO TAPES, PRODUCTION OF RADIO AND TELEVISION PROGRAMMES, RECORDING STUDIO SERVICES, ORGANIZATION OF ENTERTAINMENT EVENTS AND COMPETITIONS IN THE FIELD OF ENTERTAINMENT, MUSIC, DANCE OR FASHION; PRESENTATION OF MUSICAL PERFORMANCE; ENTERTAINMENT EVENT BOOKING AGENCIES, TICKET RESERVATION AND BOOKING SERVICES FOR ENTERTAINMENT, MUSICAL, SPORTING AND CULTURAL EVENTS; DISC JOCKEYS FOR PARTIES, MUSIC FESTIVALS AND SPECIAL EVENTS; ORGANIZATION OF MUSIC FESTIVALS (U.S. CLS. 100, 101 AND 107).

PAUL MORENO, EXAMINING ATTORNEY

SN 85-062,459. CREAM HOLDINGS LIMITED, LIVERPOOL, UNITED KINGDOM, FILED 6-14-2010.

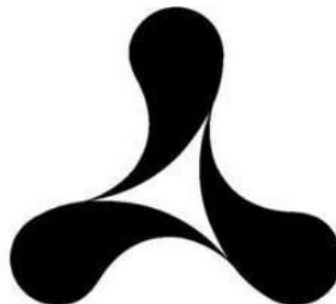

OWNER OF U.S. REG. NO. 2,796,467.

THE MARK CONSISTS OF A FAN SHAPE WITH THREE EXTENSIONS, FORMING A TRIANGLE SHAPE IN THE MIDDLE.

**CLASS 9—ELECTRICAL AND SCIENTIFIC APPARATUS**

FOR MUSICAL SOUND RECORDINGS; VIDEO RECORDINGS, AUDIOTAPES, AUDIO AND VIDEO CASSETTES, COMPACT DISCS, PHONOGRAPH RECORDS; ALL FEATURING MUSIC; ELECTRONIC GAME PROGRAMS; APPARATUS FOR RECORDING, TRANSMISSION, REPRODUCTION OF SOUND OR IMAGES, PHOTOGRAPHIC AND CINEMATIC APPARATUS AND INSTRUMENTS, NAMELY, VIDEO CASSETTE RECORDERS AND DIGITAL VIDEO RECORDERS; VIDEO RECORDERS AND VIDEO REPRODUCING APPARATUS; VIDEO OUTPUT GAME MACHINES FOR USE WITH TELEVISIONS; ELECTRONIC AMUSEMENT APPARATUS ADAPTED FOR USE WITH TELEVISION RECEIVERS, SUNGLASSES, CASES FOR SUNGLASSES, COMPACT DISC PLAYERS, TAPE RECORDERS, RADIO RECEIVERS, AUDIO CASSETTE TAPE RECORDERS, DOWNLOADABLE ELECTRONIC PUBLICATIONS IN THE NATURE OF A MAGAZINE, CATALOGUE OR NEWSLETTER IN THE FIELD OF MUSIC, DANCE, ENTERTAINMENT OR FASHION; DIGITAL MUSIC DOWNLOADABLE FROM THE INTERNET, MODEMS (U.S. CLS. 21, 23, 26, 36 AND 38).

**CLASS 25—CLOTHING**

FOR CLOTHING, NAMELY, BELTS, GLOVES, HOSIERY, JACKETS, DRESSES, SKIRTS, JUMPERS, KNITWEAR, NAMELY, JACKETS AND TOPS, COATS, TROUSERS, SHIRTS, T-SHIRTS, UNDERWEAR, FOOTWEAR AND HEADWEAR, VISORS, CAPS, SWIMSUITS, SHORTS, PANTS, SWIMSUIT COVERS, NAMELY, BEACH COVER-UPS, SOCKS AND HATS (U.S. CLS. 22 AND 39).

**CLASS 41—EDUCATION AND ENTERTAINMENT**

FOR INFORMATION RELATING TO ENTERTAINMENT, MUSIC, OR DANCE PROVIDED ON-LINE FROM A COMPUTER DATABASE OR THE INTERNET; PROVIDING ON-LINE, NON-DOWNLOADABLE PUBLICATIONS IN THE NATURE OF A MAGAZINE, CATALOGUE OR NEWSLETTER IN THE FIELD OF MUSIC, DANCE, ENTERTAINMENT OR FASHION; PROVIDING AN INTERNET WEBSITE PORTAL IN THE FIELD OF MUSIC, DANCE, ENTERTAINMENT AND LEISURE SERVICES, NAMELY, NIGHTCLUBS, DISCOTHEQUES, DANCE CLUBS; PUBLISHING OF ELECTRONIC PUBLICATIONS; ARRANGING AND CONDUCTING OF CONFERENCES RELATING TO THE MUSIC, DANCE, FASHION OR THE ENTERTAINMENT INDUSTRY FOR NON-BUSINESS AND NON-COMMERCIAL PURPOSES; DISTRIBUTION OF MOTION PICTURE FILMS, PRODUCTION OF FILMS AND VIDEO TAPES, PRODUCTION OF RADIO AND TELEVISION PROGRAMMES, RECORDING STUDIO SERVICES, ORGANIZATION OF ENTERTAINMENT EVENTS AND COMPETITIONS IN THE FIELD OF ENTERTAINMENT, MUSIC, DANCE OR FASHION; PRESENTATION OF MUSICAL PERFORMANCE; ENTERTAINMENT EVENT BOOKING AGENCIES, TICKET RESERVATION AND BOOKING SERVICES FOR ENTERTAINMENT, MUSICAL, SPORTING AND CULTURAL EVENTS; DISC JOCKEYS FOR PARTIES, MUSIC FESTIVALS AND SPECIAL EVENTS; ORGANIZATION OF MUSIC FESTIVALS (U.S. CLS. 100, 101 AND 107).

PAUL MORENO, EXAMINING ATTORNEY

SN 85-062,977. WERA-WERK HERMANN WERNER GMBH & CO. KG, WUPPERTAL, FED REP GERMANY, FILED 6-15-2010.

# IMPAKTOR

THE MARK CONSISTS OF STANDARD CHARACTERS WITHOUT CLAIM TO ANY PARTICULAR FONT, STYLE, SIZE, OR COLOR.

PRIORITY CLAIMED UNDER SEC. 44(D) ON FED REP GERMANY APPLICATION NO. 302009074767, FILED 12-17-2009, REG. NO. 302009074767, DATED 1-26-2010, EXPIRES 12-31-2019.

**CLASS 7—MACHINERY**

FOR BITS, INSERTS, FASTENERS, ADAPTORS, SOCKETS, NUT-SETTERS, CHUCKS AND BIT HOLDERS FOR POWER DRIVEN HAND-HELD TOOLS, EXCLUDING TOOLS CONNECTED TO A HORIZONTAL BORING MACHINE FOR BURSTING UNDERGROUND PIPES AND ENLARGING UNDERGROUND BORES AND EXCLUDING WIRELINE TOOLS FOR USE IN OIL AND GAS WELLS (U.S. CLS. 13, 19, 21, 23, 31, 34 AND 35).

**CLASS 8—HAND TOOLS**

FOR HAND-OPERATED TOOLS, NAMELY, HAND-OPERATED SCREWDRIVING TOOLS; BITS, INSERTS, FASTENERS, ADAPTORS, SOCKETS, NUT-SETTERS, CHUCKS AND BIT HOLDERS FOR HAND-OPERATING SCREWDRIVING TOOLS; ALL EXCLUDING TOOLS CONNECTED TO A HORIZONTAL BORING MACHINE FOR BURSTING PIPES AND ENLARGING UNDERGROUND BORES AND EXCLUDING WIRELINE TOOLS FOR USE IN OIL AND GAS WELLS (U.S. CLS. 23, 28 AND 44).

JENNY PARK, EXAMINING ATTORNEY

SN 85-063,226. HOMMA MASAOKI, TOKYO 107-0062, JAPAN, FILED 6-15-2010.



OWNER OF U.S. REG. NO. 3,445,351.

NO CLAIM IS MADE TO THE EXCLUSIVE RIGHT TO USE "JAPAN", APART FROM THE MARK AS SHOWN.

THE COLOR(S) GRAY AND BLACK IS/ARE CLAIMED AS A FEATURE OF THE MARK.

THE MARK CONSISTS OF THE WORDS "MASTERMIND JAPAN" IN STYLIZED TYPEFACE IN THE COLOR BLACK WHICH ARE LOCATED BETWEEN TWO DESIGN ELEMENTS WHICH DEPICT SKULLS WHICH ARE IN THE COLOR GRAY WITH BLACK EYE SOCKETS AND CROSS BONES IN THE COLOR GRAY.

**CLASS 14—JEWELRY**

FOR KEY RINGS OF PRECIOUS METAL; ORNAMENTS OF PRECIOUS METAL OTHER THAN CUFF LINKS; CUFF LINKS; PURSES AND WALLETS OF PRECIOUS METAL; SEMI-WROUGHT PRECIOUS STONES AND THEIR IMITATIONS; UNWROUGHT PRECIOUS STONES; CLOCKS AND WATCHES (U.S. CLS. 2, 27, 28 AND 50).

**CLASS 18—LEATHER GOODS**

FOR BAGS AND THE LIKE, NAMELY, ALL-PURPOSE CARRYING BAGS, ATHLETIC BAGS, SHOULDER BAGS, GLADSTONE BAGS, CARRY-ON BAGS, BOSTON BAGS, LEATHER SHOPPING BAGS, MESH SHOPPING BAGS, STRING SHOPPING BAGS, TEXTILE SHOPPING BAGS, SCHOOL BOOK BAGS, BACKPACKS, HANDBAGS, PURSES, WALLETS, KEY CASES, CREDIT CARD CASES, BUSINESS CARD CASES, COMMUTER TICKET CASES, BRIEFCASES AND FOLDING BRIEFCASES, SUITCASES, AND TRUNKS; POUCHES AND THE LIKE, NAMELY, POUCHES OF LEATHER, DRAWSTRING POUCHES, AND CHARM BAGS; UMBRELLAS AND THEIR PARTS; LEATHER STRAPS; RAWHIDES; RAW SKINS; TANNED LEATHER; FUR (U.S. CLS. 1, 2, 3, 22 AND 41).

**CLASS 25—CLOTHING**

FOR NON-JAPANESE STYLE OUTER CLOTHING, NAMELY, EVENING DRESSES, SUITS, SKIRTS, TROUSERS, VESTS, WAISTCOATS, OVERCOATS, TOPCOATS, MANTLES, RAINCOATS, CARDIGANS, JACKETS, ANORAKS, WIND-RESISTANT JACKETS, CHILDREN'S WEAR, NAMELY, CHILDREN'S PANTS, CHILDREN'S SWEATERS, CHILDREN'S DRESSES, CHILDREN'S SHIRTS, CHILDREN'S SKIRTS, CHILDREN'S OVERALLS, AND FORMALWEAR, NAMELY, EVENING GOWNS, TUXEDOS; COATS; SWEATERS; SHIRTS AND THE LIKE, NAMELY, TEE-SHIRTS, OPEN-NECKED SHIRTS, SPORT SHIRTS, POLO SHIRTS, SHIRTS FOR SUITS, AND BLOUSES; NIGHTWEAR; UNDERWEAR; SWIM WEAR; SWIMMING CAPS; APRONS; COLLAR PROTECTORS; SOCKS; STOCKINGS; PUTTEES; GAITERS; FUR STOLES; SHAWLS; SCARVES; JAPANESE STYLE SOCKS (TABI); GLOVES; MITTENS; NECKTIES; NECKERCHIEFS; BANDANAS; MUFFLERS; EAR MUFFS; HEADGEAR, NAMELY, HATS AND CAPS; SUSPENDERS; WAISTBANDS; BELTS FOR CLOTHING; FOOTWEAR; MASQUERADE COSTUMES; HORSE-RIDING BOOTS (U.S. CLS. 22 AND 39).

KATHERINE STOIDES, EXAMINING ATTORNEY

SN 85-066,450. MORINAGA NYUGYO KABUSHIKI KAISHA, TA MORINAGA MILK INDUSTRY CO., LTD., TOKYO, JAPAN, FILED 6-18-2010.

**L. ACIDOPHILUS LAC-361**

THE MARK CONSISTS OF STANDARD CHARACTERS WITHOUT CLAIM TO ANY PARTICULAR FONT, STYLE, SIZE, OR COLOR.

NO CLAIM IS MADE TO THE EXCLUSIVE RIGHT TO USE "L. ACIDOPHILUS", APART FROM THE MARK AS SHOWN.

**CLASS 1—CHEMICALS**

FOR LACTOBACILLUS ACIDOPHILUS BACTERIA FOR USE IN MANUFACTURING FOOD, FOOD SUPPLEMENTS FOR MEDICAL AND NON-MEDICAL PURPOSES, AND ANIMAL FOODSTUFFS (U.S. CLS. 1, 5, 6, 10, 26 AND 46).

**CLASS 5—PHARMACEUTICALS**

FOR LACTOBACILLUS ACIDOPHILUS BACTERIA FOR MEDICAL USE (U.S. CLS. 6, 18, 44, 46, 51 AND 52). ERNEST SHOSHO, EXAMINING ATTORNEY

SN 85-066,452. DCD DESIGN & MANUFACTURING LTD., RICHMOND, BC, CANADA, FILED 6-18-2010.

**TUBE-LUBE**

THE MARK CONSISTS OF STANDARD CHARACTERS WITHOUT CLAIM TO ANY PARTICULAR FONT, STYLE, SIZE, OR COLOR.

OWNER OF U.S. REG. NO. 2,834,273.

**CLASS 4—LUBRICANTS AND FUELS**

FOR INDUSTRIAL LUBRICANTS FOR PULLING CABLE THROUGH DUCTING (U.S. CLS. 1, 6 AND 15). FIRST USE 7-31-2002; IN COMMERCE 7-31-2002.

**CLASS 7—MACHINERY**

FOR POWER-OPERATED, HAND-HELD DISPENSERS FOR ATTACHMENT TO CONTAINERS FOR USE IN DISPENSING INDUSTRIAL LUBRICANTS AND APPLICATORS FOR ATTACHMENT TO POWER-OPERATED, HAND-HELD DISPENSERS FOR DISPENSING INDUSTRIAL LUBRICANTS (U.S. CLS. 13, 19, 21, 23, 31, 34 AND 35).

FIRST USE 5-10-2007; IN COMMERCE 5-10-2007.

**CLASS 8—HAND TOOLS**

FOR MANUALLY ACTUATED PUMP DISPENSERS FOR ATTACHMENT TO CONTAINERS FOR USE IN DISPENSING INDUSTRIAL LUBRICANTS (U.S. CLS. 23, 28 AND 44).

FIRST USE 7-31-2002; IN COMMERCE 7-31-2002.

MARTHA SANTOMARTINO, EXAMINING ATTORNEY

SN 85-066,875. SPEARS MANUFACTURING CO., SYLMAR, CA. FILED 6-18-2010.

**EVERTUFF**

THE MARK CONSISTS OF STANDARD CHARACTERS WITHOUT CLAIM TO ANY PARTICULAR FONT, STYLE, SIZE, OR COLOR.

**CLASS 19—NON-METALLIC BUILDING MATERIALS**

FOR NON-METAL RIGID PIPES, RIGID PLASTIC PIPES, PIPE FITTING SOLVENT CEMENTS, NON-METAL PIPE FITTINGS, NAMELY, 90-DEGREE ELLS, SIDE OUTLET ELLS, 90-DEGREE REDUCING ELLS, SPRINKLER HEAD 90-DEGREE ELLS, 45-DEGREE ELLS, 45-DEGREE STREET ELLS, 22 1/2-DEGREE ELLS, 22 1/2-DEGREE STREET ELLS, TEES, REDUCING TEES, ELLS, REDUCING ELLS, WYES, REDUCING WYES, COUPLINGS, REDUCING COUPLINGS, CROSSES, REDUCING CROSSES, STREET ELLS, BUSHINGS, UNIONS, FLANGES, ADAPTERS, NAMELY, MALE, FEMALE AND TRANSITION ADAPTERS (U.S. CLS. 1, 12, 33 AND 50).

FIRST USE 8-4-2008; IN COMMERCE 8-4-2008.

**CLASS 20—FURNITURE AND ARTICLES NOT OTHERWISE CLASSIFIED**

FOR PLASTIC MANUALLY-OPERATED VALVES, PLASTIC MANUALLY-OPERATED CHECK VALVES AND PLASTIC MANUALLY-OPERATED DRAIN VALVES (U.S. CLS. 2, 13, 22, 25, 32 AND 50).

FIRST USE 6-1-2010; IN COMMERCE 6-1-2010.

KATHLEEN LORENZO, EXAMINING ATTORNEY

SN 85-068,174. COLLABORATIVE MEDIA, LLC, NEWPORT BEACH, CA. FILED 6-21-2010.

**Pacific Festival OC**

SN 85-067,741. SUDDATH VAN LINES, INC., JACKSONVILLE, FL. FILED 6-21-2010.

**RELOCATION ZONE**

THE MARK CONSISTS OF STANDARD CHARACTERS WITHOUT CLAIM TO ANY PARTICULAR FONT, STYLE, SIZE, OR COLOR.

NO CLAIM IS MADE TO THE EXCLUSIVE RIGHT TO USE "RELOCATION", APART FROM THE MARK AS SHOWN.

THE MARK CONSISTS OF STANDARD CHARACTERS WITHOUT CLAIM TO ANY PARTICULAR FONT, STYLE, SIZE, OR COLOR.

NO CLAIM IS MADE TO THE EXCLUSIVE RIGHT TO USE "FESTIVAL OC", APART FROM THE MARK AS SHOWN.

**CLASS 25—CLOTHING**

FOR HATS; SHIRTS; SWEAT SHIRTS; T-SHIRTS (U.S. CLS. 22 AND 39).

**CLASS 41—EDUCATION AND ENTERTAINMENT**

FOR ENTERTAINMENT IN THE NATURE OF ORGANIZING AND PRODUCING LIVE MUSICAL EVENTS, ART SHOWS, FASHION SHOWS, AND TECHNOLOGY SHOWS (U.S. CLS. 100, 101 AND 107).

CHARLES L. JENKINS, EXAMINING ATTORNEY

**CLASS 35—ADVERTISING AND BUSINESS**

FOR TRANSPORTATION LOGISTICS SERVICES, NAMELY, ARRANGING THE TRANSPORTATION OF GOODS FOR OTHERS; ORDER FULFILLMENT SERVICES; LOGISTICS MANAGEMENT IN THE FIELD OF TRANSPORTATION AND STORAGE SERVICES (U.S. CLS. 100, 101 AND 102).

SN 85-069,030. FIRMLY PLANTED, INC., VALLEY VILLAGE, CA. FILED 6-22-2010.

**CLASS 36—INSURANCE AND FINANCIAL**

FOR PERSONAL EXPENSE ADMINISTRATION, NAMELY, ADMINISTERING FOR EMPLOYEES OF OTHERS THE EMPLOYEES RELOCATION BENEFITS; RELOCATION ASSISTANCE, NAMELY, REAL ESTATE BROKERAGE (U.S. CLS. 100, 101 AND 102).

**CLASS 39—TRANSPORTATION AND STORAGE**

FOR TRANSPORT, PACKAGING, TRUCKING, HAULING AND STORAGE OF GOODS, NAMELY, DOMESTIC AND INTERNATIONAL HOUSEHOLD GOODS; PORTABLE CONTAINERIZED STORAGE, MOVING, STORAGE, AND TRANSPORTATION SERVICES BY TRUCK, RAIL, AIR AND BOAT. WAREHOUSING SERVICES, FREIGHT AND TRANSPORTATION BROKERAGE SERVICES, AND FREIGHT FORWARDING SERVICES FEATURING THE TRANSPORTATION OF GOODS AND PERSONAL EFFECTS FOR OTHERS, FOR GENERAL FREIGHT AND HOUSEHOLD GOODS; TRANSPORTATION OF GOODS BY TRUCK, AIR, RAIL AND BOAT; PACKING ARTICLES OTHER THAN HOUSEHOLD GOODS FOR TRANSPORTATION AND STORAGE; FREIGHT STATION SERVICES, NAMELY, CARGO HANDLING IN THE NATURE OF PICKUP, RECEIVING, CONSOLIDATION AND DISTRIBUTION THEREOF DOMESTICALLY AND INTERNATIONALLY; MOVE MANAGEMENT, NAMELY, TRANSPORTATION OF HOUSEHOLD GOODS BY TRUCK, AIR, RAIL AND BOAT (U.S. CLS. 100 AND 105).

KATHLEEN LORENZO, EXAMINING ATTORNEY

THE MARK CONSISTS OF THE WORDING "FIRMLY PLANTED" AND A FANCIFUL DEPICTION OF A TREE WITH THE TRUNK SEPARATING THE TWO WORDS IN THE MARK AND HAVING EXPOSED ROOTS AND FLOWER DESIGNS IN THE LEAVES.

**CLASS 14—JEWELRY**

FOR CLOCKS (U.S. CLS. 2, 27, 28 AND 50).

**CLASS 20—FURNITURE AND ARTICLES NOT OTHERWISE CLASSIFIED**

FOR PILLOWS, PICTURE FRAMES, FURNITURE FRAMES, DOG BEDS, AND DECORATIVE NON-METAL HOUSE NUMBERS FOR CREATING ADDRESSES ON THE SIDE OF ONE'S HOUSE OR PLACE OF BUSINESS (U.S. CLS. 2, 13, 22, 25, 32 AND 50).

**CLASS 44—MEDICAL, BEAUTY AND AGRICULTURAL SERVICES**

FOR LANDSCAPE DESIGN AND GARDENING; PROVIDING ONLINE INFORMATION IN THE FIELD OF LANDSCAPE DESIGN AND GARDENING; CONSULTATION SERVICES IN THE FIELD OF LANDSCAPE DESIGN AND GARDENING (U.S. CLS. 100 AND 101).

FIRST USE 9-0-2009; IN COMMERCE 9-0-2009.  
MATTHEW MCDOWELL, EXAMINING ATTORNEY

SN 85-069,187. LOSADA, MARIA CAMILA, MIAMI, FL. FILED 6-22-2010.

**MAKY LOSADA**

THE MARK CONSISTS OF STANDARD CHARACTERS WITHOUT CLAIM TO ANY PARTICULAR FONT, STYLE, SIZE, OR COLOR.

THE NAME(S), PORTRAIT(S), AND/OR SIGNATURE(S) SHOWN IN THE MARK IDENTIFIES MARIA CAMILA LOSADA, WHOSE CONSENT(S) TO REGISTER IS MADE OF RECORD.

**CLASS 18—LEATHER GOODS**

FOR PURSES AND WALLETS (U.S. CLS. 1, 2, 3, 22 AND 41).

**CLASS 25—CLOTHING**

FOR SHOES AND BELTS (U.S. CLS. 22 AND 39).  
SUNG IN, EXAMINING ATTORNEY

SN 85-069,789. SPRINT COMMUNICATIONS COMPANY L.P., OVERLAND PARK, KS. FILED 6-23-2010.



THE COLOR(S) GREEN IS/ARE CLAIMED AS A FEATURE OF THE MARK.

THE MARK CONSISTS OF A GREEN WIRELESS TELEPHONE SURROUNDED BY THREE GREEN CLOCKWISE DIRECTIONAL ARROWS. THE COLOR WHITE REPRESENTS BACKGROUND AND IS NOT PART OF THE MARK NOR CLAIMED AS A COLOR FEATURE OF THE MARK.

**CLASS 35—ADVERTISING AND BUSINESS**

FOR PROVIDING A BUYBACK AND TRADE-IN PROGRAM FOR USED WIRELESS TELEPHONES (U.S. CLS. 100, 101 AND 102).

FIRST USE 10-20-2009; IN COMMERCE 10-20-2009.

**CLASS 40—MATERIAL TREATMENT**

FOR RECYCLING OF WIRELESS TELEPHONE EQUIPMENT AND ACCESSORIES, NAMELY, WIRELESS TELEPHONES, BATTERIES FOR WIRELESS TELEPHONES AND WIRELESS DATA CARDS (U.S. CLS. 100, 103 AND 106).

FIRST USE 10-20-2009; IN COMMERCE 10-20-2009.  
H. M. FISHER, EXAMINING ATTORNEY

SN 85-070,591. JAEHNIG, LISA, SPRINGFIELD, OR. FILED 6-24-2010.

**KHARMIC JUSTICE**

THE MARK CONSISTS OF STANDARD CHARACTERS WITHOUT CLAIM TO ANY PARTICULAR FONT, STYLE, SIZE, OR COLOR.

**CLASS 9—ELECTRICAL AND SCIENTIFIC APPARATUS**

FOR SPORTS GLASSES AND SPORTS GLASSES ACCESSORIES, NAMELY, EYE GLASSES, SUN GLASSES, SKI GLASSES, GOGGLES, GLASSES FOR SPORTS, AND CASES, CHAINS, AND CORDS FOR EYE GLASSES, SUN GLASSES, SKI GLASSES, GOGGLES, GLASSES FOR SPORTS (U.S. CLS. 21, 23, 26, 36 AND 38).

FIRST USE 11-12-2010; IN COMMERCE 11-12-2010.

**CLASS 14—JEWELRY**

FOR SPORTS JEWELRY AND SPORTS JEWELRY ACCESSORIES, NAMELY, JEWELRY, WATCHES, CHAINS, CHARMS, BROOCHES, BRACELETS, PINS, PENDANTS, RINGS, JEWELRY CASES, JEWELRY BOXES, JEWELRY ORGANIZERS (U.S. CLS. 2, 27, 28 AND 50).

FIRST USE 11-12-2010; IN COMMERCE 11-12-2010.

**CLASS 25—CLOTHING**

FOR SPORTSWEAR AND SPORTSWEAR ACCESSORIES, NAMELY, TOPS, BOTTOMS, PANTS, JACKETS, HATS, SHOES, SOCKS, CAPS, BEANIES, GLOVES, HEAD BANDS, WRIST BANDS (U.S. CLS. 22 AND 39).

FIRST USE 11-12-2010; IN COMMERCE 11-12-2010.  
STEVEN PEREZ, EXAMINING ATTORNEY

SN 85-070,598. FOOD FOR HEALTH INTERNATIONAL, DBA FOOD FOR HEALTH, INT, PROVO, UT. FILED 6-24-2010.

**Food For Health**

THE MARK CONSISTS OF STANDARD CHARACTERS WITHOUT CLAIM TO ANY PARTICULAR FONT, STYLE, SIZE, OR COLOR.

NO CLAIM IS MADE TO THE EXCLUSIVE RIGHT TO USE "FOOD", APART FROM THE MARK AS SHOWN.

**CLASS 5—PHARMACEUTICALS**

FOR DIETARY FIBER AS AN ADDITIVE FOR FOOD PRODUCTS; DIETARY FOOD SUPPLEMENTS; ENZYME FOOD SUPPLEMENTS; FOOD FOR DIABETICS; FOOD SUPPLEMENTS; FOOD SUPPLEMENTS, NAMELY, ANTI-OXIDANTS; HEALTH FOOD SUPPLEMENTS; NUTRITIONAL FOOD BARS FOR USE AS A MEAL REPLACEMENT; VITAMIN AND MINERAL PREPARATIONS FOR USE AS INGREDIENTS IN THE FOOD AND PHARMACEUTICAL INDUSTRY (U.S. CLS. 6, 18, 44, 46, 51 AND 52).

FIRST USE 1-1-2001; IN COMMERCE 1-1-2001.

**CLASS 20—FURNITURE AND ARTICLES NOT OTHERWISE CLASSIFIED**

FOR PACKAGING MATERIALS, NAMELY, PLASTIC SHIPPING AND STORAGE BOXES; PLASTIC CONTAINERS AND COVERS FOR THE FOOD INDUSTRY; PLASTIC CONTAINERS FOR COMMERCIAL USE, NAMELY, FOR STORING AND DISPENSING BULK FOODS; PLASTIC SHIPPING AND STORAGE BOXES; PLASTIC STORAGE DRUMS (U.S. CLS. 2, 13, 22, 25, 32 AND 50).

FIRST USE 1-1-2001; IN COMMERCE 1-1-2001.

**CLASS 29—MEATS AND PROCESSED FOODS**

FOR FOOD ADDITIVES, NAMELY, NATURAL FOOD EXTRACTS DERIVED FROM FISH, FISH OIL, FISH PROTEIN, ALGAE, SEAWEED, FISH OR SHARK CARTILAGE, OR SEASHELLS NOT FOR MEDICINAL PURPOSES AND FOR HUMAN CONSUMPTION; FRUIT-BASED FOOD BEVERAGE; FRUIT-BASED ORGANIC FOOD BARS; SOY BEAN OIL; SOY PROTEIN FOR USE AS A FOOD ADDITIVE; SOY-BASED FOOD BARS; SOY-BASED SNACK FOODS (U.S. CL. 46).

FIRST USE 1-1-2001; IN COMMERCE 1-1-2001.

**CLASS 30—STAPLE FOODS**

FOR FOOD SEASONINGS; GRAIN-BASED SNACK FOODS; MULTIGRAIN-BASED SNACK FOODS; WHEAT FLOUR (U.S. CL. 46).

FIRST USE 1-1-2001; IN COMMERCE 1-1-2001.

**CLASS 39—TRANSPORTATION AND STORAGE**

FOR DELIVERY AND STORAGE OF GOODS; STORAGE AND DELIVERY OF GOODS (U.S. CLS. 100 AND 105).

FIRST USE 1-1-2001; IN COMMERCE 1-1-2001.

**CLASS 40—MATERIAL TREATMENT**

FOR FOOD PROCESSING (U.S. CLS. 100, 103 AND 106).

FIRST USE 1-1-2001; IN COMMERCE 1-1-2001.

**CLASS 42—SCIENTIFIC AND COMPUTER SERVICES**

FOR FOOD RESEARCH; RESEARCH ON FOOD; SCIENTIFIC CONSULTING AND RESEARCH SERVICES RELATING TO FOODS AND DIETARY SUPPLEMENTS; TECHNICAL CONSULTANCY IN RELATION TO RESEARCH SERVICES RELATING TO FOODS AND DIETARY SUPPLEMENTS; TECHNICAL CONSULTANCY IN RELATION TO THE DEVELOPMENT OF TECHNOLOGIES AND TECHNICAL COMPONENTS FOR FOOD; TECHNICAL CONSULTANCY IN RELATION TO THE TECHNICAL RESEARCH IN THE FIELD OF FOOD AND BEVERAGES (U.S. CLS. 100 AND 101).

FIRST USE 1-1-2001; IN COMMERCE 1-1-2001.

JULIE GUTTADAURO, EXAMINING ATTORNEY

SN 85-070,767. BOY SCOUTS OF AMERICA, IRVING, TX. FILED 6-24-2010.

# ZEROWIND

THE MARK CONSISTS OF STANDARD CHARACTERS WITHOUT CLAIM TO ANY PARTICULAR FONT, STYLE, SIZE, OR COLOR.

**CLASS 20—FURNITURE AND ARTICLES NOT OTHERWISE CLASSIFIED**

FOR SLEEPING BAGS (U.S. CLS. 2, 13, 22, 25, 32 AND 50).

**CLASS 22—CORDAGE AND FIBERS**

FOR TENTS (U.S. CLS. 1, 2, 7, 19, 22, 42 AND 50).

**CLASS 25—CLOTHING**

FOR CLOTHING, NAMELY, SHIRTS, KNIT SHIRTS, POLO SHIRTS, T-SHIRTS, SWEATSHIRTS, WOVEN SHIRTS, WOVEN BOTTOMS, TROUSERS, SHORTS, KNIT BOTTOMS, RAINWEAR, JACKETS, PANTS, OUTERWEAR, NAMELY, COATS AND PULLOVERS, HEADWEAR, GLOVES, SOCKS AND SCARVES (U.S. CLS. 22 AND 39).

WANDA KAY PRICE, EXAMINING ATTORNEY

SN 85-070,770. EVANTAGE TECHNOLOGIES LLC, WATER-TOWN, CT. FILED 6-24-2010.

# CarboTRAK

THE MARK CONSISTS OF STANDARD CHARACTERS WITHOUT CLAIM TO ANY PARTICULAR FONT, STYLE, SIZE, OR COLOR.

**CLASS 7—MACHINERY**

FOR CARBONATORS FOR USE WITH BEVERAGE DISPENSING MACHINES, NAMELY, IN-LINE APPARATUS FOR DISSOLVING CARBON DIOXIDE GAS IN SUPPLIED FLUIDS; APPARATUS FOR ADJUSTING FOR CHANGES IN THE TEMPERATURE OF THE SUPPLIED FLUIDS FEATURING REGULATORS BEING PARTS OF MACHINES (U.S. CLS. 13, 19, 21, 23, 31, 34 AND 35).

**CLASS 9—ELECTRICAL AND SCIENTIFIC APPARATUS**

FOR SYSTEMS FOR BEVERAGE DISPENSING EQUIPMENT, CONSISTING PRIMARILY OF COMPUTER SOFTWARE FOR USE IN MONITORING USAGE LEVELS OF CARBON DIOXIDE, SYRUP, DRINK FLAVOURINGS AND BEVERAGES AND FOR COLLECTING DATA FOR INVENTORY AND MARKETING PURPOSES, FLUID SENSORS, IN-LINE CARBONATORS, AND REMOTE DATA TRANSMITTERS (U.S. CLS. 21, 23, 26, 36 AND 38).

EMILY CHUO, EXAMINING ATTORNEY

SN 85-071,123. IDDEA CALIFORNIA, LLC, BREA, CA. FILED 6-24-2010.



THE MARK CONSISTS OF THE WORD "BIG" IN STYLIZED FONT FOLLOWED BY THE WORD "COUNTRY" IN A STENCIL-LIKE STYLIZED FONT WITH EACH LETTER PLACED WITHIN A RECTANGLE; BOTH WORDS ARE ENCLOSED WITHIN AN ELONGATED OVAL SHAPE.

#### CLASS 7—MACHINERY

FOR AUTOMOTIVE AFTERMARKET PARTS AND ACCESSORIES, NAMELY, ENGINE EXHAUST TIPS (U.S. CLS. 13, 19, 21, 23, 31, 34 AND 35).

FIRST USE 11-1-2002; IN COMMERCE 11-1-2002.

#### CLASS 12—VEHICLES

FOR AUTOMOTIVE AFTERMARKET PARTS AND ACCESSORIES, NAMELY, SIDE BARS, FRONT GUARDS IN THE NATURE OF BRUSH GUARDS, BUMPER GUARDS, GRILL GUARDS AND UNDER-CARRIAGE GUARDS, BED RAILS, AND LUGGAGE AND SPORTS RACKS FOR VEHICLES (U.S. CLS. 19, 21, 23, 31, 35 AND 44).

FIRST USE 11-1-2002; IN COMMERCE 11-1-2002.

JENNY PARK, EXAMINING ATTORNEY

SN 85-071,827. READY SET, INC., BROOKLYN, NY. FILED 6-25-2010.



NO CLAIM IS MADE TO THE EXCLUSIVE RIGHT TO USE "NYC", APART FROM THE MARK AS SHOWN.

THE MARK CONSISTS OF THE LETTERS "RS NYC" SUPERIMPOSED ON A SHIELD WITH A CHECKERBOARD DESIGN ACROSS THE TOP, TOPPED BY A CROWN.

#### CLASS 25—CLOTHING

FOR CLOTHING, NAMELY, T-SHIRTS, SWEAT-SHIRTS, JACKETS (U.S. CLS. 22 AND 39).

FIRST USE 11-1-2004; IN COMMERCE 11-1-2004.

#### CLASS 40—MATERIAL TREATMENT

FOR CUSTOM FABRICATION OF SETS AND SCENIC ENVIRONMENTS FOR PHOTOGRAPHY SHOOTS, TRADE SHOWS, THEMED EVENTS, SPECIAL EVENTS, RETAIL AND PROMOTIONAL DISPLAYS, CONVENTIONS AND MARKETING PRESENTATIONS, BROADCAST EVENTS, AND CORPORATE EVENTS (U.S. CLS. 100, 103 AND 106).

FIRST USE 11-1-2004; IN COMMERCE 11-1-2004.

JULIE WATSON, EXAMINING ATTORNEY

SN 85-072,809. BLUEGREEN CORPORATION, BOCA RATON, FL. FILED 6-28-2010.



NO CLAIM IS MADE TO THE EXCLUSIVE RIGHT TO USE "EXCHANGE", APART FROM THE MARK AS SHOWN.

THE COLOR(S) GREEN, GOLD, ORANGE, BLUE, PURPLE, PINK, GRAY AND BLACK IS/ARE CLAIMED AS A FEATURE OF THE MARK.

THE MARK CONSISTS OF A MULTI-COLORED PINWHEEL DESIGN IN THE COLORS GREEN, GOLD, ORANGE, BLUE, PURPLE AND PINK. TO THE RIGHT OF THE PINWHEEL DESIGN, THE WORD "PRIZZMA" APPEARS IN THE COLOR GRAY. THE WORDS "THE FUN EXCHANGE." APPEAR BELOW THE WORD "PRIZZMA" WITH THE WORDS "THE" AND "EXCHANGE." APPEARING IN THE COLOR BLACK AND THE WORD "FUN" APPEARING IN THE COLOR PURPLE.

THE WORD(S) "PRIZZMA" HAS NO MEANING IN A FOREIGN LANGUAGE.

#### CLASS 35—ADVERTISING AND BUSINESS

FOR MARKETING CONSULTING SERVICES; ADVERTISING SERVICES, NAMELY, ADVERTISING REAL ESTATE PROPERTIES FOR RENTAL BY MEANS OF BROCHURES, CATALOGUES, AND OVER A GLOBAL TELECOMMUNICATIONS NETWORK; CONSULTING SERVICES FOR RESORT PROPERTIES, NAMELY, REAL ESTATE SALES MANAGEMENT (U.S. CLS. 100, 101 AND 102).

#### CLASS 36—INSURANCE AND FINANCIAL

FOR REAL ESTATE SERVICES, NAMELY, RENTAL OF VACATION HOMES, CONDOMINIUMS, CABINS, AND VILLAS; REAL ESTATE TIME-SHARE EXCHANGE SERVICES; REAL ESTATE MANAGEMENT; REAL ESTATE MANAGEMENT CONSULTATION; REAL ESTATE OWNERSHIP EXCHANGE SERVICES, NAMELY, VACATION REAL ESTATE TIME SHARING, REAL ESTATE MANAGEMENT AND LEASING SERVICES, AND CONSULTING SERVICES FOR RESORT PROPERTIES, NAMELY, LEASING AND MANAGEMENT OF RESORT PROPERTIES (U.S. CLS. 100, 101 AND 102).

#### CLASS 43—HOTEL AND RESTAURANT SERVICES

FOR ARRANGING TEMPORARY HOUSING ACCOMMODATIONS; BOOKING OF CAMPGROUND ACCOMMODATION; CONSULTING SERVICES IN THE FIELD OF HOSPITALITY; PROVIDING TRAVEL LODGING INFORMATION SERVICES AND TRAVEL LODGING BOOKING AGENCY SERVICES FOR TRAVELERS; TRAVEL AGENCY SERVICES, NAMELY, MAKING RESERVATIONS AND BOOKING FOR TEMPORARY LODGING (U.S. CLS. 100 AND 101).

NELSON SNYDER, EXAMINING ATTORNEY



SN 85-073,928. ELEVATE ORAL CARE, LLC, WELLINGTON, FL. FILED 6-29-2010.

SN 85-073,944. ELEVATE ORAL CARE, LLC, WELLINGTON, FL. FILED 6-29-2010.

# Elevate

# Elevate Oral Care

THE MARK CONSISTS OF STANDARD CHARACTERS WITHOUT CLAIM TO ANY PARTICULAR FONT, STYLE, SIZE, OR COLOR.

THE MARK CONSISTS OF STANDARD CHARACTERS WITHOUT CLAIM TO ANY PARTICULAR FONT, STYLE, SIZE, OR COLOR.

NO CLAIM IS MADE TO THE EXCLUSIVE RIGHT TO USE "ORAL CARE", APART FROM THE MARK AS SHOWN.

## CLASS 3—COSMETICS AND CLEANING PREPARATIONS

FOR DENTAL CARE PREPARATIONS FOR CLEANING AND REMOVAL OF PLAQUE, NAMELY, DENTAL CLEANER GELS, DENTIFRICES, ORAL RINSES, MOUTH WIPES AND TOOTH WHITENERS (U.S. CLS. 1, 4, 6, 50, 51 AND 52).

## CLASS 3—COSMETICS AND CLEANING PREPARATIONS

FOR DENTAL CARE PREPARATIONS FOR CLEANING AND REMOVAL OF PLAQUE, NAMELY, DENTAL CLEANER GELS, DENTIFRICES, ORAL RINSES, MOUTH WIPES AND TOOTH WHITENERS (U.S. CLS. 1, 4, 6, 50, 51 AND 52).

## CLASS 5—PHARMACEUTICALS

FOR MEDICATED DENTAL CARE PREPARATIONS FOR PREVENTION AND REMOVAL OF PLAQUE AND/OR BACTERIA, FOR REMINERALIZATION OF ENAMEL, FOR PROTECTION OF ENAMEL AND GINGIVAL TISSUE AND FOR DESENSITIZATION OR PAIN RELIEF OF THE MOUTH, GUMS AND TEETH, NAMELY, MEDICATED DENTAL DENTIFRICES, DENTAL GELS, ORAL RINSES, MOUTH SPRAYS, FLUORIDE TREATMENTS, REMINERALIZATION AGENTS, DENTAL FOAMS, ANALGESICS, ANTIBIOTICS, TOPICAL FLUORIDE PREPARATIONS, DENTAL CREAMS, PROPHYLAXIS POWDERS, PROPHYLAXIS PASTES, TOOTH VARNISHES, SEALANTS AND DISCLOSING AGENTS (U.S. CLS. 6, 18, 44, 46, 51 AND 52).

## CLASS 5—PHARMACEUTICALS

FOR MEDICATED DENTAL CARE PREPARATIONS FOR PREVENTION AND REMOVAL OF PLAQUE AND/OR BACTERIA, FOR REMINERALIZATION OF ENAMEL, FOR PROTECTION OF ENAMEL AND GINGIVAL TISSUE AND FOR DESENSITIZATION OR PAIN RELIEF OF THE MOUTH, GUMS AND TEETH, NAMELY, MEDICATED DENTAL DENTIFRICES, DENTAL GELS, ORAL RINSES, MOUTH SPRAYS, FLUORIDE TREATMENTS, REMINERALIZATION AGENTS, DENTAL FOAMS, ANALGESICS, ANTIBIOTICS, TOPICAL FLUORIDE PREPARATIONS, DENTAL CREAMS, PROPHYLAXIS POWDERS, PROPHYLAXIS PASTES, TOOTH VARNISHES, SEALANTS AND DISCLOSING AGENTS (U.S. CLS. 6, 18, 44, 46, 51 AND 52).

## CLASS 10—MEDICAL APPARATUS

FOR DENTAL INSTRUMENTS AND APPARATUS FOR THE AID IN DIAGNOSING CARIES ACTIVITY, PERIODONTAL DISEASE AND OTHER BACTERIAL ACTIVITY, NAMELY, DENTAL PICKS, EXPLORERS, PROBES, FLUORESCENCE EMITTING EXPOSING LIGHTS, X-RAY APPARATUS FOR DENTAL USE, X-RAY APPLIANCES FOR DENTAL USE, AND X-RAY DIAGNOSTIC APPARATUS FOR DENTAL USE; DENTAL PRODUCTS FOR CLEANING AND REMOVAL OF PLAQUE, NAMELY, TONGUE CLEANERS, PROPHYLAXIS ANGLES, PROPHYLAXIS BRUSHES AND PROPHYLAXIS CUPS (U.S. CLS. 26, 39 AND 44).

## CLASS 10—MEDICAL APPARATUS

FOR DENTAL INSTRUMENTS AND APPARATUS FOR THE AID IN DIAGNOSING CARIES ACTIVITY, PERIODONTAL DISEASE AND OTHER BACTERIAL ACTIVITY, NAMELY, DENTAL PICKS, EXPLORERS, PROBES, FLUORESCENCE EMITTING EXPOSING LIGHTS, X-RAY APPARATUS FOR DENTAL USE, X-RAY APPLIANCES FOR DENTAL USE, AND X-RAY DIAGNOSTIC APPARATUS FOR DENTAL USE; DENTAL PRODUCTS FOR CLEANING AND REMOVAL OF PLAQUE, NAMELY, TONGUE CLEANERS, PROPHYLAXIS ANGLES, PROPHYLAXIS BRUSHES AND PROPHYLAXIS CUPS (U.S. CLS. 26, 39 AND 44).

## CLASS 21—HOUSEWARES AND GLASS

FOR DENTAL PRODUCTS FOR CLEANING AND REMOVAL OF PLAQUE, NAMELY, DENTAL FLOSS, DENTAL FLOSS DISPENSERS, DENTAL FLOSS HOLDERS, TOOTHBRUSHES, INTERDENTAL BRUSHES (U.S. CLS. 2, 13, 23, 29, 30, 33, 40 AND 50).  
HENRY S. ZAK, EXAMINING ATTORNEY

## CLASS 21—HOUSEWARES AND GLASS

FOR DENTAL PRODUCTS FOR CLEANING AND REMOVAL OF PLAQUE, NAMELY, DENTAL FLOSS, DENTAL FLOSS DISPENSERS, DENTAL FLOSS HOLDERS, TOOTHBRUSHES, INTERDENTAL BRUSHES (U.S. CLS. 2, 13, 23, 29, 30, 33, 40 AND 50).  
HENRY S. ZAK, EXAMINING ATTORNEY

SN 85-075,866. CORPORATION SERVICE COMPANY, WILMINGTON, DE. FILED 7-1-2010.

## CSCNAVIGATOR

THE MARK CONSISTS OF STANDARD CHARACTERS WITHOUT CLAIM TO ANY PARTICULAR FONT, STYLE, SIZE, OR COLOR.  
OWNER OF U.S. REG. NOS. 2,630,508, 3,065,312 AND OTHERS.

### CLASS 35—ADVERTISING AND BUSINESS

FOR PROVIDING AN INTERNET PORTAL FEATURING LINKS TO INFORMATION ABOUT BUSINESS AND BUSINESS ENTITY FORMATION, BRAND RESEARCH, TRADEMARK MONITORING SERVICES, AND CREATION AND BRAND ESTABLISHMENT OF DOMAIN NAMES (U.S. CLS. 100, 101 AND 102).

### CLASS 36—INSURANCE AND FINANCIAL

FOR PROVIDING AN INTERNET PORTAL FEATURING LINKS TO INFORMATION ABOUT ESCROW SERVICES AND FINANCIAL SERVICES (U.S. CLS. 100, 101 AND 102).

### CLASS 45—PERSONAL AND LEGAL SERVICES

FOR PROVIDING AN INTERNET PORTAL FEATURING LINKS TO INFORMATION ABOUT LITIGATION SERVICES, TRADEMARK SEARCHING AND CLEARANCE SERVICES, AND DOMAIN NAME REGISTRATION SERVICES (U.S. CLS. 100 AND 101).

DAVID TOOLEY, EXAMINING ATTORNEY

SN 85-076,845. PAPPAS, CYNTHIA, MT. GILEAD, OH. FILED 7-2-2010.

## PEREGRINE WARRIOR

THE MARK CONSISTS OF STANDARD CHARACTERS WITHOUT CLAIM TO ANY PARTICULAR FONT, STYLE, SIZE, OR COLOR.

### CLASS 25—CLOTHING

FOR SPORTING GOODS, NAMELY, JIU JITSU UNIFORM, RASH GUARD, MIXED MARTIAL ARTS SHORTS, JUDO UNIFORM, BOXING SHOES, MUAY THAI SHORTS, ATHLETIC UNIFORMS, COMBATIVE SPORTS UNIFORMS, TANK TOPS, GLOVES, AND MOTORCYCLE GLOVES (U.S. CLS. 22 AND 39).

### CLASS 28—TOYS AND SPORTING GOODS

FOR SPORTING GOODS, NAMELY, BOXING GLOVES, GRAPPLING GLOVES, SPARRING GLOVES, WORK OUT GLOVES, PUNCHING MITT, ATHLETIC EQUIPMENT, NAMELY, GUARDS FOR THE CHEST AND PADS FOR USE IN MARTIAL ARTS; ATHLETIC EQUIPMENT, NAMELY, HEAD GUARD AND SHIN GUARD FOR ATHLETIC USE, ATHLETIC EQUIPMENT, NAMELY, HAND WRAP, MOUTH GUARD, JUMP ROPE, PUNCHING BAGS, AND SOCCER BALLS (U.S. CLS. 22, 23, 38 AND 50).

PATRICIA EVANKO, EXAMINING ATTORNEY

SN 85-078,310. CLOUDBRAIN, LLC, CHARLOTTESVILLE, VA. FILED 7-6-2010.

## Save the Songs

THE MARK CONSISTS OF STANDARD CHARACTERS WITHOUT CLAIM TO ANY PARTICULAR FONT, STYLE, SIZE, OR COLOR.

### CLASS 9—ELECTRICAL AND SCIENTIFIC APPARATUS

FOR COMPUTER SOFTWARE FOR DATABASE MANAGEMENT FOR THE USE WITH DIGITAL MUSIC FILES AND ALBUM ART; DOWNLOADABLE COMPUTER SOFTWARE FOR DATABASE MANAGEMENT FOR THE USE WITH DIGITAL MUSIC FILES AND ALBUM ART (U.S. CLS. 21, 23, 26, 36 AND 38).

### CLASS 42—SCIENTIFIC AND COMPUTER SERVICES

FOR PROVIDING A WEB SITE FEATURING TECHNOLOGY THAT ENABLES USERS TO PROCESS DIGITAL MUSIC FILES (U.S. CLS. 100 AND 101).

AMEEN IMAM, EXAMINING ATTORNEY

SN 85-078,634. TREND MICRO KABUSHIKI KAISHA, TA TREND MICRO INCORPORATED, SHIBUYA-KU, TOKYO, JAPAN, FILED 7-6-2010.

## Trend Micro NAS Security

THE MARK CONSISTS OF STANDARD CHARACTERS WITHOUT CLAIM TO ANY PARTICULAR FONT, STYLE, SIZE, OR COLOR.

NO CLAIM IS MADE TO THE EXCLUSIVE RIGHT TO USE "NAS SECURITY", APART FROM THE MARK AS SHOWN.

**CLASS 9—ELECTRICAL AND SCIENTIFIC APPARATUS**

FOR COMPUTER UTILITY SOFTWARE; COMPUTER ANTIVIRUS SOFTWARE; COMPUTER NETWORK SECURITY SOFTWARE; COMPUTER SOFTWARE FOR USE WITH ELECTRONIC MAIL, LOCAL AREA NETWORK, INTERNAL CORPORATE NETWORK, FILE, GROUPWARE APPLICATION, AND PROXY SERVERS; COMPUTER SOFTWARE FOR FILTERING INFORMATION RETRIEVED FROM COMPUTER NETWORKS, INCLUDING GLOBAL COMPUTER INFORMATION NETWORKS; COMPUTER SOFTWARE FOR DIAGNOSING AND REPAIRING COMPUTERS AND COMPUTER SOFTWARE; INSTRUCTION MANUALS SUPPLIED AS A UNIT WITH THE FOREGOING; COMPUTER SOFTWARE FOR NETWORK SECURITY, NETWORK MANAGEMENT, PROTECTION AND RECOVERY FROM COMPUTER VIRUSES, COPY PROTECTION, TRANSFERRING DATA BETWEEN PORTABLE COMPUTING DEVICES AND DESKTOP AND NETWORKED COMPUTERS, AND FOR LINKING TEXT RECORDS WITH ELECTRONIC IMAGES; COMPUTER SOFTWARE FOR MONITORING AND MODIFYING MESSAGES, FILES, AND DATA RECEIVED OVER COMPUTER NETWORKS; USER MANUALS SUPPLIED THEREWITH (U.S. CLS. 21, 23, 26, 36 AND 38).

**CLASS 42—SCIENTIFIC AND COMPUTER SERVICES**

FOR SERVICES OF DESIGN, INSTALLATION, MAINTENANCE, AND UPDATING OF COMPUTER SOFTWARE FOR DATA AND COMPUTER SECURITY SOLUTIONS AGAINST VIRUSES, SPAM, MALWARE AND OTHER TYPE OF WEB ATTACKS; CONSULTANCY CONCERNING SOFTWARE FOR DATA AND COMPUTER SECURITY SOLUTIONS AGAINST VIRUSES, SPAM, MALWARE AND OTHER TYPE OF WEB ATTACKS; RENTAL OF SOFTWARE FOR DATA AND COMPUTER SECURITY SOLUTIONS AGAINST VIRUSES, SPAM, MALWARE AND OTHER TYPE OF WEB ATTACKS (U.S. CLS. 100 AND 101).

AISHA CLARKE, EXAMINING ATTORNEY

SN 85-080,323. MILPIX SA, MEYLAN, FRANCE, FILED 7-8-2010.



THE MARK CONSISTS OF A STYLIZED CAMERA AND A PLUS SIGN NEAR THE UPPER RIGHT-HAND CORNER OF THE CAMERA.

**CLASS 35—ADVERTISING AND BUSINESS**

FOR PROVIDING ONLINE PROMOTIONAL, ADVERTISING AND MARKETING SERVICES; PROVIDING CONSUMER PRODUCT INFORMATION AND BUSINESS ADVICE TO PROSPECTIVE PURCHASERS; PROVIDING ON-LINE CONSUMER PRODUCT INFORMATION AND BUSINESS ADVICE TO PROSPECTIVE PURCHASERS (U.S. CLS. 100, 101 AND 102).

**CLASS 42—SCIENTIFIC AND COMPUTER SERVICES**

FOR COMPUTER SERVICES, NAMELY, PROVIDING SEARCH ENGINES FOR OBTAINING DATA ON THE INTERNET OR OTHER COMPUTER OR COMMUNICATIONS NETWORKS; COMPUTER SERVICES, NAMELY, CREATING INDEXES OF INFORMATION, SITES AND OTHER RESOURCES AVAILABLE ON THE INTERNET OR OTHER COMPUTER OR COMMUNICATIONS NETWORKS; COMPUTER SERVICES, NAMELY, UPLOADING IMAGES, MESSAGES, AUDIO WORKS, AUDIOVISUAL WORKS, VISUAL WORKS AND MULTIMEDIA WORKS TO THE INTERNET OR OTHER COMPUTER OR COMMUNICATIONS NETWORKS FOR OTHERS; COMPUTER SERVICES, NAMELY, PROVIDING SEARCH PLATFORMS TO ALLOW USERS TO REQUEST CONTENT FROM AND RECEIVE CONTENT TO A MOBILE DEVICE; COMPUTER SERVICES, NAMELY, PROVIDING ON-LINE NON-DOWNLOADABLE SOFTWARE ENABLING USERS TO UPLOAD CONTENT TO A MOBILE DEVICE; DESIGN AND DEVELOPMENT OF COMPUTER SOFTWARE; DEVELOPING AND MANAGING APPLICATION SOFTWARE AND DATABASES FOR DELIVERY OF IMAGES, MESSAGES, AUDIO, VISUAL, AUDIOVISUAL AND MULTIMEDIA WORKS FOR USE ON MOBILE DEVICES; COMPUTER SERVICES, NAMELY, PROVIDING ON-LINE NON-DOWNLOADABLE E-COMMERCE SOFTWARE TO ALLOW USERS TO PERFORM ELECTRONIC BUSINESS TRANSACTIONS VIA A GLOBAL COMPUTER NETWORK (U.S. CLS. 100 AND 101).

KATHERINE CONNOLLY, EXAMINING ATTORNEY

SN 85-080,575. TILDEN, GAIL DIANE, WOODINVILLE, WA. FILED 7-8-2010.

# Muttles

THE MARK CONSISTS OF STANDARD CHARACTERS WITHOUT CLAIM TO ANY PARTICULAR FONT, STYLE, SIZE, OR COLOR.

**CLASS 16—PAPER GOODS AND PRINTED MATTER**

FOR CARDS, NAMELY, TRADING CARDS (U.S. CLS. 2, 5, 22, 23, 29, 37, 38 AND 50).  
FIRST USE 1-14-2009; IN COMMERCE 2-14-2010.

**CLASS 28—TOYS AND SPORTING GOODS**

FOR PLUSH TOYS (U.S. CLS. 22, 23, 38 AND 50).  
FIRST USE 1-14-2009; IN COMMERCE 2-14-2010.  
SALLY SHIH, EXAMINING ATTORNEY

SN 85-080,788. FRIEDMAN, MIKE, LOS ANGELES, CA. FILED 7-8-2010.

# SOFTJOCKS

THE MARK CONSISTS OF STANDARD CHARACTERS WITHOUT CLAIM TO ANY PARTICULAR FONT, STYLE, SIZE, OR COLOR.

**CLASS 25—CLOTHING**

FOR CLOTHING, NAMELY, T-SHIRTS, SLEEVELESS SHIRTS, SWEATSHIRTS, HATS, SHORTS, WARM-UP PANTS, SWIMWEAR, PAJAMAS, SOCKS, UNDERWEAR, COSTUMES FOR USE IN CHILDREN'S DRESS UP PLAY, AND COSTUMES FOR USE IN ROLE-PLAYING GAMES (U.S. CLS. 22 AND 39).

**CLASS 28—TOYS AND SPORTING GOODS**

FOR TOYS, NAMELY, PLUSH TOYS AND DOLLS, STUFFED TOYS AND DOLLS, SOFT SCULPTURE TOYS AND DOLLS, DOLL CLOTHING, ARTICLES OF CLOTHING FOR TOYS, AND DOLL ACCESSORIES (U.S. CLS. 22, 23, 38 AND 50).

ROBERT C. CLARK JR., EXAMINING ATTORNEY

SN 85-081,033. MUSCULOSKELETAL TRANSPLANT FOUNDATION, EDISON, NJ. FILED 7-9-2010.

# ENHANCE

THE MARK CONSISTS OF STANDARD CHARACTERS WITHOUT CLAIM TO ANY PARTICULAR FONT, STYLE, SIZE, OR COLOR.

**CLASS 5—PHARMACEUTICALS**

FOR ALLOGRAFT MATERIAL, NAMELY, HUMAN BONE AND TISSUE AND GROWTH FACTORS, NAMELY, PROTEINS FOR PROMOTING TISSUE GROWTH AND REPAIR, PROCESSED INTO SURGICAL IMPLANTS, SCAFFOLDS AND PLUGS FOR THE REPAIR AND REPLACEMENT OF HUMAN BONE AND TISSUE DEFECTS IN EXTREMITIES (U.S. CLS. 6, 18, 44, 46, 51 AND 52).

**CLASS 10—MEDICAL APPARATUS**

FOR SURGICAL IMPLANTS MADE FROM SYNTHETIC MATERIALS FOR THE REPAIR AND REPLACEMENT OF HUMAN BONE AND TISSUE DEFECTS IN EXTREMITIES; SURGICAL IMPLANTS MADE FROM METAL FOR THE REPAIR AND REPLACEMENT OF HUMAN BONE AND TISSUE DEFECTS IN EXTREMITIES (U.S. CLS. 26, 39 AND 44).

SETH A. RAPPAPORT, EXAMINING ATTORNEY

SN 85-081,103. WHITMOR, INC., SOUTHAVEN, MS. FILED 7-9-2010.

# RATTIQUE

THE MARK CONSISTS OF STANDARD CHARACTERS WITHOUT CLAIM TO ANY PARTICULAR FONT, STYLE, SIZE, OR COLOR.

OWNER OF U.S. REG. NO. 2,943,830.

**CLASS 20—FURNITURE AND ARTICLES NOT OTHERWISE CLASSIFIED**

FOR DRAWER ORGANIZERS MADE OF PLASTIC THAT IS WOVEN TO CREATE THE LOOK OF RATTAN (U.S. CLS. 2, 13, 22, 25, 32 AND 50).

FIRST USE 6-7-2010; IN COMMERCE 6-7-2010.

**CLASS 21—HOUSEWARES AND GLASS**

FOR LAUNDRY BASKETS AND BASKETS FOR DOMESTIC USE MADE OF PLASTIC THAT IS WOVEN TO CREATE THE LOOK OF RATTAN (U.S. CLS. 2, 13, 23, 29, 30, 33, 40 AND 50).

FIRST USE 7-31-2004; IN COMMERCE 7-31-2004.

LINDA M. KING, EXAMINING ATTORNEY

SN 85-082,700. PLANTLY, LLC, BROOKLYN, NY. FILED 7-12-2010.

# PLANTLY

THE MARK CONSISTS OF STANDARD CHARACTERS WITHOUT CLAIM TO ANY PARTICULAR FONT, STYLE, SIZE, OR COLOR.

**CLASS 36—INSURANCE AND FINANCIAL**

FOR PROVIDING A WEBSITE WHERE ONE CAN OBTAIN ONLINE FINANCIAL AND INVESTMENT CONSULTING, ANALYSIS, AND INFORMATION (U.S. CLS. 100, 101 AND 102).

FIRST USE 5-25-2010; IN COMMERCE 5-25-2010.

**CLASS 42—SCIENTIFIC AND COMPUTER SERVICES**

FOR PROVIDING TEMPORARY USE OF ONLINE NON-DOWNLOADABLE SOFTWARE FOR FINANCIAL AND INVESTMENT PLANNING (U.S. CLS. 100 AND 101).

FIRST USE 5-25-2010; IN COMMERCE 5-25-2010.

MICHELLE DUBOIS, EXAMINING ATTORNEY

SN 85-083,427. HOMEGOODS, INC., FRAMINGHAM, MA. FILED 7-13-2010.

# LOVE AND CUPCAKES

THE MARK CONSISTS OF STANDARD CHARACTERS WITHOUT CLAIM TO ANY PARTICULAR FONT, STYLE, SIZE, OR COLOR.

NO CLAIM IS MADE TO THE EXCLUSIVE RIGHT TO USE "CUPCAKES" AS TO ALL OF THE GOODS IN CLASS 21 AND TOY COOKWARE AND BAKE WARE IN CLASS 28, APART FROM THE MARK AS SHOWN.

**CLASS 21—HOUSEWARES AND GLASS**

FOR BAKEWARE; DINNERWARE; AND SERVINGWARE FOR SERVING FOOD AND DRINKS (U.S. CLS. 2, 13, 23, 29, 30, 33, 40 AND 50).

**CLASS 24—FABRICS**

FOR KITCHEN LINENS; TABLE LINEN; BED LINEN, BED SHEETS, SHEET SETS, BEDSPREADS, BED BLANKETS, COMFORTERS, BED SKIRTS, AND PILLOW SHAMS; FABRIC WINDOW COVERINGS AND TREATMENTS, NAMELY, CURTAINS, SHEERS, SWAGS, AND VALANCES; CRIB BUMPERS AND CRIB CANOPIES (U.S. CLS. 42 AND 50).

SN 85-084,049. PAYTON, BRENDA F, DBA BRENDA'S SON, PEORIA, IL. FILED 7-14-2010.

# Brenda's Son

**CLASS 28—TOYS AND SPORTING GOODS**

FOR TOY BAKEWARE AND COOKWARE; CHILDREN'S TOYS, NAMELY, BLOCKS, PEG BOXES AND SETS, TOY CONSTRUCTION AND BUILDING SETS, TOY BANKS, PLUSH STUFFED TOY ANIMALS, TOY CARS AND TOY TRAINS, AND PUZZLES; CRIB TOYS (U.S. CLS. 22, 23, 38 AND 50).

THE MARK CONSISTS OF STANDARD CHARACTERS WITHOUT CLAIM TO ANY PARTICULAR FONT, STYLE, SIZE, OR COLOR.

**CLASS 30—STAPLE FOODS**

FOR CANDY (U.S. CL. 46).  
H. M. FISHER, EXAMINING ATTORNEY

**CLASS 9—ELECTRICAL AND SCIENTIFIC APPARATUS**

FOR MOUSEPADS, MAGNETS (U.S. CLS. 21, 23, 26, 36 AND 38).

**CLASS 16—PAPER GOODS AND PRINTED MATTER**

FOR GREETING CARDS, MONTHLY PLANNERS, NOTEPADS, NOTE-CARDS, BOOKMARKERS, CALENDARS, STATIONARY, POSTCARDS (U.S. CLS. 2, 5, 22, 23, 29, 37, 38 AND 50).  
WILLIAM VERHOSEK, EXAMINING ATTORNEY

SN 85-083,607. ZIPHER MEDICAL AFFAIRS COMPANY, LLC, MARION, MA. FILED 7-13-2010.

# ZIPHER

SN 85-084,153. SAN LI FOOD CO., LTD., KAOHSIUNG HSIEN, TAIWAN, FILED 7-14-2010.

THE MARK CONSISTS OF STANDARD CHARACTERS WITHOUT CLAIM TO ANY PARTICULAR FONT, STYLE, SIZE, OR COLOR.

**CLASS 35—ADVERTISING AND BUSINESS**

FOR PROVIDING BUSINESS MANAGEMENT AND CONSULTING SERVICES AND BUSINESS DATA ANALYSIS SERVICES IN THE FIELD OF MEDICAL AFFAIRS, NAMELY, CLINICAL DATA AND REGULATORY SUBMISSION CONSULTING AND MANAGEMENT ON BEHALF OF MEDICAL, BIOPHARMACEUTICAL AND BIOTECHNOLOGY COMPANIES TO ASSIST THEM WITH CLINICAL RESEARCH AND CLINICAL TRIALS; MARKETING CONSULTATION RELATED TO THE COMMERCIALIZATION OF APPROVED DRUGS AND MEDICAL DEVICES (U.S. CLS. 100, 101 AND 102).  
FIRST USE 12-1-2008; IN COMMERCE 12-1-2008.

THE MARK CONSISTS OF THE LETTERS "U" AND "MAY" SEPARATED BY A PERIOD, FOLLOWED BY TWO CHINESE CHARACTERS.

THE NON-LATIN CHARACTERS IN THE MARK TRANSLITERATE TO "U MAY" AND THIS MEANS "WONDERFUL MAY" IN ENGLISH.

**CLASS 41—EDUCATION AND ENTERTAINMENT**

FOR EDUCATION SERVICES, NAMELY, PROVIDING CLASSES, SEMINARS AND WORKSHOPS IN THE FIELD OF MEDICAL AFFAIRS (U.S. CLS. 100, 101 AND 107).

FIRST USE 12-1-2008; IN COMMERCE 12-1-2008.  
CHRIS WELLS, EXAMINING ATTORNEY

**CLASS 29—MEATS AND PROCESSED FOODS**

FOR ANIMAL MILK; FLAVORED MILK; LACTIC ACID BACTERIA DRINKS; RICE AND PEANUT MILK; TOFU PUDDINGS; JELLIES; JELLY POWDER; GRASS JELLIES; JELLY FIGS; COFFEE JELLIES; ALMOND JELLIES; COCONUT JELLIES; KONJAC JELLIES; PECTIN FOR FOODS; EDIBLE GELATIN, NAMELY, UNFLAVORED AND UNSWEETENED GELATINS; RED BEAN SWEET SOUPS; GREEN BEAN SWEET SOUPS; PEANUT SWEET SOUPS; FRUIT AND VEGETABLE SPREAD; PRESERVED FRUITS AND VEGETABLES (U.S. CL. 46).

FIRST USE 6-30-2010; IN COMMERCE 6-30-2010.

**CLASS 30—STAPLE FOODS**

FOR COFFEES; INSTANT COFFEE BAGS; DRINKS MADE FROM COFFEES; DRINKS MADE FROM TEAS; ICE CREAMS; SAUCES; CANDIES; RICE COOKIES; COOKIES; CEREAL FLAKES; BREAD; STARCH PEARL; SAGO; PUDDINGS; PUDDING POWDER; RICE CONGEE; PLAIN COOKED RICE; INSTANT NOODLES; AGAR NOODLES; EDIBLE GELATIN, NAMELY, FLAVORED AND SWEETENED GELATINS (U.S. CL. 46).

FIRST USE 6-30-2010; IN COMMERCE 6-30-2010.

**CLASS 32—LIGHT BEVERAGES**

FOR BEERS; SODAS; JUICES; MINERAL WATER; FRUIT AND VEGETABLE DRINKS; HERB TEA BAGS; RYE JUICES; GRASS JELLY DRINKS; DRINK WITH COCONUT JELLIES; DRINKS CONTAINING VINEGAR; SAGO DRINKS; COCONUT MILK WITH SAGO; FRUIT ACID DRINKS; PECTIN DRINKS; SEAWEED DRINKS; JELLY DRINKS; VINEGAR; DRINKS CONTAINING SUGAR CANDY AND SWALLOW NEST; BOILED GRASS JELLIES; EDIBLE GELATIN DRINKS (U.S. CLS. 45, 46 AND 48).

FIRST USE 6-30-2010; IN COMMERCE 6-30-2010.

RONALD AIKENS, EXAMINING ATTORNEY

SN 85-084,363. CONTEMPORARY DESIGN GROUP, INC., SAN DIEGO, CA. FILED 7-14-2010.



THE MARK CONSISTS OF A ROUNDED-CORNER SQUARE SHAPE WITH A CURVED DIVIDING LINE THAT BISECTS THE SHAPE.

**CLASS 20—FURNITURE AND ARTICLES NOT OTHERWISE CLASSIFIED**

FOR FURNITURE (U.S. CLS. 2, 13, 22, 25, 32 AND 50).  
FIRST USE 12-31-1986; IN COMMERCE 1-31-1988.

**CLASS 35—ADVERTISING AND BUSINESS**

FOR RETAIL FURNITURE STORES (U.S. CLS. 100, 101 AND 102).  
FIRST USE 12-31-1986; IN COMMERCE 1-31-1988.  
JEFFREY LOOK, EXAMINING ATTORNEY

SN 85-084,784. THOMAS MICHAEL RIDDLE, SAN JOSE, CA.  
FILED 7-14-2010.

# MAXX12

THE MARK CONSISTS OF STANDARD CHARACTERS WITHOUT CLAIM TO ANY PARTICULAR FONT, STYLE, SIZE, OR COLOR.

**CLASS 25—CLOTHING**

FOR CLOTHING AS MERCHANDISE AND FAN ARTICLES, NAMELY, T-SHIRTS, SHORTS, SLEEPWEAR, SWIMWEAR, UNDERWEAR, FOOTWEAR, TOPS, BOTTOMS, SHIRTS, PANTS, DRESSES, COATS, JACKETS, SWEATSHIRTS, SWEATERS AND VESTS, JEANS, TROUSERS, SOCKS, BELTS AND JUMPERS; AND HEADWEAR, NAMELY, HATS, CAPS AND BANDANAS (U.S. CLS. 22 AND 39).

**CLASS 41—EDUCATION AND ENTERTAINMENT**

FOR ENTERTAINMENT SERVICES, NAMELY, LIVE MUSICAL CONCERTS AND CONCERT TOURS; MUSIC PUBLISHING SERVICES; MUSIC FAN CLUB SERVICES; PROVIDING AN ON-LINE COMPUTER DATABASE FEATURING PRERECORDED MUSIC, MUSICAL PERFORMANCES, MUSIC VIDEOS, MUSIC VIDEO CLIPS, MUSIC FILMS, AND MULTIMEDIA MATERIALS FEATURING MUSIC; PROVIDING AN ON-LINE COMPUTER DATABASE FEATURING ENTERTAINMENT INFORMATION ABOUT A MUSICAL BAND, NAMELY, GRAPHICS, DATA, NEWS, REVIEWS, PHOTOGRAPHS, TOUR SCHEDULES, TRAVEL SCHEDULES, MUSICAL PERFORMANCE SCHEDULES, SCHEDULED RELEASE DATES FOR AUDIO, VIDEO AND DIGITAL RECORDINGS, MULTI-MEDIA SOFTWARE, COLLECTIBLE GOODS AND PRINTED MATTER (U.S. CLS. 100, 101 AND 107).

PATRICIA EVANKO, EXAMINING ATTORNEY

SN 85-086,507. THE UNIVERSAL CHURCH, NEWARK, NJ.  
FILED 7-16-2010.



THE COLOR(S) RED, BLACK AND WHITE IS/ARE CLAIMED AS A FEATURE OF THE MARK.

THE MARK CONSISTS OF A RED LETTER "Y" TO THE LEFT, A BLACK LETTER "G" TO THE RIGHT, AND IN THE CENTER A WHITE LETTER "P" POSITIONED INSIDE A PARTIAL DESIGN OF A WHITE CIRCLE SET AGAINST A BLACK BACKGROUND WITH A RED PERIMETER.

**CLASS 16—PAPER GOODS AND PRINTED MATTER**

FOR NEWSLETTERS AND INFORMATIONAL BROCHURES ALL ABOUT RELIGIOUS BELIEFS AND PRACTICES (U.S. CLS. 2, 5, 22, 23, 29, 37, 38 AND 50).  
FIRST USE 2-24-2008; IN COMMERCE 2-24-2008.

**CLASS 25—CLOTHING**

FOR T-SHIRTS DISTRIBUTED IN CONNECTION WITH A RELIGIOUS GROUP (U.S. CLS. 22 AND 39).  
FIRST USE 2-24-2008; IN COMMERCE 2-24-2008.

**CLASS 45—PERSONAL AND LEGAL SERVICES**

FOR RELIGIOUS COUNSELING AND MINISTERIAL SERVICES (U.S. CLS. 100 AND 101).  
FIRST USE 2-24-2008; IN COMMERCE 2-24-2008.  
RUSS HERMAN, EXAMINING ATTORNEY

SN 85-086,556. THE UNIVERSAL CHURCH, NEWARK, NJ.  
FILED 7-16-2010.

**YOUTH POWER GROUP**

THE MARK CONSISTS OF STANDARD CHARACTERS WITHOUT CLAIM TO ANY PARTICULAR FONT, STYLE, SIZE, OR COLOR.

NO CLAIM IS MADE TO THE EXCLUSIVE RIGHT TO USE "YOUTH" AND "GROUP", APART FROM THE MARK AS SHOWN.

**CLASS 16—PAPER GOODS AND PRINTED MATTER**

FOR NEWSLETTERS AND INFORMATIONAL BROCHURES ALL ABOUT RELIGIOUS BELIEFS AND PRACTICES (U.S. CLS. 2, 5, 22, 23, 29, 37, 38 AND 50).  
FIRST USE 2-24-2008; IN COMMERCE 2-24-2008.

**CLASS 25—CLOTHING**

FOR T-SHIRTS DISTRIBUTED IN CONNECTION WITH A RELIGIOUS GROUP (U.S. CLS. 22 AND 39).  
FIRST USE 2-24-2008; IN COMMERCE 2-24-2008.

**CLASS 45—PERSONAL AND LEGAL SERVICES**

FOR RELIGIOUS COUNSELING AND MINISTERIAL SERVICES (U.S. CLS. 100 AND 101).  
FIRST USE 2-24-2008; IN COMMERCE 2-24-2008.  
RUSS HERMAN, EXAMINING ATTORNEY

SN 85-087,908. AGRI-FAB, INC., SULLIVAN, IL. FILED 7-19-2010.

**LAWN CARE MADE EASY**

THE MARK CONSISTS OF STANDARD CHARACTERS WITHOUT CLAIM TO ANY PARTICULAR FONT, STYLE, SIZE, OR COLOR.

NO CLAIM IS MADE TO THE EXCLUSIVE RIGHT TO USE "LAWN CARE", APART FROM THE MARK AS SHOWN.

**CLASS 7—MACHINERY**

FOR LAWN VACUUMS; REEL LAWN MOWERS; POWER-OPERATED AND/OR TRACTOR-TOWED LAWN EQUIPMENT, NAMELY, LAWN GROOMERS, LAWN SWEEPERS, LAWN SPREADERS FOR SEED AND DRY LAWN CHEMICAL, DETHATCHERS, LAWN AERATORS, TILLERS, SEEDERS, SOIL SPIKERS, FINISH CUT LAWN MOWERS, ROUGH CUT LAWN MOWERS, POWER OPERATED SPRAYERS; ATTACHMENTS FOR TRACTOR-TOWED LAWN IMPLEMENTS, NAMELY, LAWN SWEEPERS, LAWN SPREADERS, LAWN CARTS, LAWN DETHATCHERS, LAWN AERATORS, LAWN ROLLERS, LAWN SPRAYERS, LAWN ROUGH CUT MOWERS, LAWN VACUUMS; MECHANICAL LAWN TOOLS, NAMELY, LAWN GROOMERS (U.S. CLS. 13, 19, 21, 23, 31, 34 AND 35).

**CLASS 8—HAND TOOLS**

FOR MANUALLY-OPERATED LAWN EQUIPMENT, NAMELY, LAWN SWEEPERS, LAWN SPREADERS FOR SEED AND DRY LAWN CHEMICALS, DETHATCHERS, SEEDERS, SOIL SPIKERS; HAND-OPERATED LAWN TOOLS, NAMELY, LAWN GROOMERS; LAWN MAINTENANCE EQUIPMENT, NAMELY, LAWN ROLLERS (U.S. CLS. 23, 28 AND 44).

**CLASS 12—VEHICLES**

FOR NON-MOTORIZED UTILITY CARTS, NAMELY, DUMP CARTS, LAWN CARTS AND GARDEN CARTS; SLEEVE HITCH ATTACHMENTS FOR GARDEN TRACTORS; THREE POINT HITCH ATTACHMENTS TO CONNECT POWER OPERATED OR TRACTOR TOWED LAWN EQUIPMENT TO TRACTORS (U.S. CLS. 19, 21, 23, 31, 35 AND 44).

REBECCA EISINGER, EXAMINING ATTORNEY

SN 85-087,916. AGRI-FAB, INC., SULLIVAN, IL. FILED 7-19-2010.

**AGRI-FAB ATTACHMENTS  
LAWN CARE MADE EASY**

THE MARK CONSISTS OF STANDARD CHARACTERS WITHOUT CLAIM TO ANY PARTICULAR FONT, STYLE, SIZE, OR COLOR.

OWNER OF U.S. REG. NOS. 2,170,857, 2,176,173 AND 3,307,194.

NO CLAIM IS MADE TO THE EXCLUSIVE RIGHT TO USE "ATTACHMENTS" AND "LAWN CARE", APART FROM THE MARK AS SHOWN.

**CLASS 7—MACHINERY**

FOR LAWN VACUUMS; REEL LAWN MOWERS; POWER-OPERATED AND/OR TRACTOR-TOWED LAWN EQUIPMENT, NAMELY, LAWN GROOMERS, LAWN SWEEPERS, LAWN SPREADERS FOR SEED AND DRY LAWN CHEMICAL, DETHATCHERS, LAWN AERATORS, TILLERS, SEEDERS, SOIL SPIKERS, FINISH CUT LAWN MOWERS, ROUGH CUT LAWN MOWERS, POWER OPERATED SPRAYERS; ATTACHMENTS FOR TRACTOR-TOWED LAWN IMPLEMENTS, NAMELY, LAWN SWEEPERS, LAWN SPREADERS, LAWN CARTS, LAWN DETHATCHERS, LAWN AERATORS, LAWN ROLLERS, LAWN SPRAYERS, LAWN ROUGH CUT MOWERS, LAWN VACUUMS; MECHANICAL LAWN TOOLS, NAMELY, LAWN GROOMERS (U.S. CLS. 13, 19, 21, 23, 31, 34 AND 35).

**CLASS 8—HAND TOOLS**

FOR MANUALLY-OPERATED LAWN EQUIPMENT, NAMELY, LAWN SWEEPERS, LAWN SPREADERS FOR SEED AND DRY LAWN CHEMICALS, DETHATCHERS, SEEDERS, SOIL SPIKERS; HAND-OPERATED LAWN TOOLS, NAMELY, LAWN GROOMERS; LAWN MAINTENANCE EQUIPMENT, NAMELY, LAWN ROLLERS (U.S. CLS. 23, 28 AND 44).

**CLASS 12—VEHICLES**

FOR NON-MOTORIZED UTILITY CARTS, NAMELY, DUMP CARTS, LAWN CARTS AND GARDEN CARTS; SLEEVE HITCH ATTACHMENTS FOR GARDEN TRACTORS; THREE POINT HITCH ATTACHMENTS TO CONNECT POWER OPERATED OR TRACTOR TOWED LAWN EQUIPMENT TO TRACTORS (U.S. CLS. 19, 21, 23, 31, 35 AND 44).

REBECCA EISINGER, EXAMINING ATTORNEY

SN 85-088,077. CITY OF LOS ANGELES, LOS ANGELES, CA. FILED 7-19-2010.

**LOTUS FESTIVAL**

THE MARK CONSISTS OF STANDARD CHARACTERS WITHOUT CLAIM TO ANY PARTICULAR FONT, STYLE, SIZE, OR COLOR.

NO CLAIM IS MADE TO THE EXCLUSIVE RIGHT TO USE "FESTIVAL", APART FROM THE MARK AS SHOWN.

**CLASS 25—CLOTHING**

FOR CLOTHING, NAMELY, T-SHIRTS, SWEAT-SHIRTS, SCARFS, FOOTWEAR AND HEADWEAR (U.S. CLS. 22 AND 39).

**CLASS 41—EDUCATION AND ENTERTAINMENT**

FOR ENTERTAINMENT SERVICES, NAMELY, CONDUCTING EVENTS SHOWCASING ASIAN AND PACIFIC ISLANDER CULTURES THROUGH ARTISANS-AT-WORK, LIVE MUSIC, DANCE, PERFORMING ARTS, ARTWORKS, CALLIGRAPHY AND HANDICRAFTS, AND ASIAN AND PACIFIC ISLANDER CUISINE; EDUCATIONAL SERVICES, NAMELY, CONDUCTING EVENTS SHOWCASING ASIAN AND PACIFIC ISLANDER CULTURES THROUGH ARTISANS-AT-WORK, LIVE MUSIC, DANCE, PERFORMING ARTS, EDUCATIONAL LECTURES AND TUTORIALS, ARTWORKS, CALLIGRAPHY AND HANDICRAFTS, AND ASIAN AND PACIFIC ISLANDER CUISINE; CULTURAL ACTIVITIES, NAMELY, CIVIC EVENTS IN THE FORM OF ART FESTIVALS AND CONCERTS (U.S. CLS. 100, 101 AND 107).

FIRST USE 7-1-1997; IN COMMERCE 7-1-1997.  
MICHAEL ENGEL, EXAMINING ATTORNEY

SN 85-088,821. GARDEN STATE SPINE & PAIN INSTITUTE, LLC, OAKHURST, NJ. FILED 7-20-2010.

**SOUL FOCUS**

THE MARK CONSISTS OF STANDARD CHARACTERS WITHOUT CLAIM TO ANY PARTICULAR FONT, STYLE, SIZE, OR COLOR.

**CLASS 41—EDUCATION AND ENTERTAINMENT**

FOR PERSONAL FITNESS TRAINING SERVICES AND CONSULTANCY; AND PERSONAL TRAINING SERVICES, NAMELY, STRENGTH AND CONDITIONING TRAINING; AND PHYSICAL FITNESS AND EXERCISE STUDIO SERVICES, NAMELY, PROVIDING GROUP EXERCISE INSTRUCTION, TAI CHI AND YOGA INSTRUCTION (U.S. CLS. 100, 101 AND 107).

**CLASS 44—MEDICAL, BEAUTY AND AGRICULTURAL SERVICES**

FOR MEDICAL TESTING SERVICES, NAMELY, FITNESS EVALUATION; MEDICAL SERVICES, NAMELY, NON-SURGICAL MEDICAL PAIN MANAGEMENT, NAMELY, TRIGGER POINT, EPIDURAL, FACET JOINT AND KNEE INJECTIONS OF ANALGESICS; PHYSICAL THERAPY; NON-SURGICAL SPINAL DECOMPRESSION THERAPY, NAMELY, SPINAL DISC REHABILITATION THROUGH THE STRETCHING OF THE SPINE IN ORDER TO SEPARATE THE VERTEBRAE AND RELIEVE DISC IMPINGEMENT ON NERVE ROOTS AND THE THECAL SAC; ACUPUNCTURE; CHIROPRACTIC SERVICES; AND PHYSICIAN-SUPERVISED WEIGHT MANAGEMENT SERVICES, NAMELY, PROVIDING WEIGHT LOSS AND/OR WEIGHT MANAGEMENT PROGRAMS (U.S. CLS. 100 AND 101).

BILL DAWE, EXAMINING ATTORNEY

SN 85-088,866. EUE/SCREEN GEMS LTD, NEW YORK, NY. FILED 7-20-2010.

**CRUX**

THE MARK CONSISTS OF STANDARD CHARACTERS WITHOUT CLAIM TO ANY PARTICULAR FONT, STYLE, SIZE, OR COLOR.

**CLASS 35—ADVERTISING AND BUSINESS**

FOR BUSINESS MANAGEMENT AND CONSULTATION IN THE FIELD OF FILM PRODUCTION, VIDEO PRODUCTION, AND WEB DEVELOPMENT (U.S. CLS. 100, 101 AND 102).

**CLASS 41—EDUCATION AND ENTERTAINMENT**

FOR DIGITAL CONTENT PRODUCTION SERVICES, NAMELY MOTION PICTURE PRODUCTION, ANIMATION PRODUCTION, FILM AND VIDEO PRODUCTION (U.S. CLS. 100, 101 AND 107).



**CLASS 42—SCIENTIFIC AND COMPUTER SERVICES**

FOR WEB SITE DEVELOPMENT FOR OTHERS; CREATION, DESIGN, DEVELOPMENT AND MAINTENANCE OF WEB SITES FOR THIRD PARTIES (U.S. CLS. 100 AND 101).

JANICE KIM, EXAMINING ATTORNEY

SN 85-092,276. EZELL, YOLANDA, LOS ANGELES, CA. FILED 7-24-2010.

**MS. KNOCKOUT**

THE MARK CONSISTS OF STANDARD CHARACTERS WITHOUT CLAIM TO ANY PARTICULAR FONT, STYLE, SIZE, OR COLOR.

THE NAME(S), PORTRAIT(S), AND/OR SIGNATURE(S) SHOWN IN THE MARK IDENTIFIES THE NICKNAME OF YOLANDA EZELL, WHOSE CONSENT(S) TO REGISTER IS MADE OF RECORD.

SN 85-091,705. AMERICA NEW YORK RI WANG FOOD GROUP CO. LTD., MASPETH, NY. FILED 7-23-2010.



NO CLAIM IS MADE TO THE EXCLUSIVE RIGHT TO USE "FOOD" AND THE NON-LATIN CHARACTERS THAT TRANSLITERATE TO MEI GUO, SHI PING, AND JI TUAN, APART FROM THE MARK AS SHOWN.

THE MARK CONSISTS OF AN OVAL CIRCLE WHICH CONTAINS A CARTOON DRAWING OF THE SUN, A MOUNTAIN AND A RIVER. ON TOP OF THE DRAWING, THERE ARE ENGLISH WORDS READING RI WANG FOOD, AND BENEATH IT THERE ARE TEN NON-LATIN CHARACTERS.

THE ENGLISH TRANSLATION OF "RI WANG" IN THE MIDDLE OF THE MARK CARRIES NO PARTICULAR MEANING. THE NON-LATIN CHARACTERS IN THE MIDDLE OF THE MARK TRANSLITERATES "RI" AND THIS GENERALLY MEANS DAY, DATE OR SUN; AND TRANSLITERATES "WANG" AND THIS GENERALLY MEANS PROSPER OR FLOURISH. THE ENGLISH TRANSLATION OF THE NON-LATIN CHARACTERS APPEARING AT THE BOTTOM OF THE MARK IS APPLICANT'S NAME. THE NON-LATIN CHARACTERS TRANSLITERATE MEI GUO AND THIS MEANS THE UNITED STATES OF AMERICA; TRANSLITERATE "RI WANG" WHICH CARRIES NO SPECIAL MEANING; TRANSLITERATE SHI PING WHICH MEAN FOOD; AND TRANSLITERATE JI TUAN WHICH MEAN GROUP.

**CLASS 29—MEATS AND PROCESSED FOODS**

FOR FOOD, NAMELY, FISH BALLS STUFFED WITH PORK FILLINGS, PORK BALLS STUFFED WITH PORK FILLINGS OR FISH FILLINGS, BEEF BALLS STUFFED WITH PORK FILLINGS, CHICKEN BALLS STUFFED WITH PORK FILLINGS, CUTTLEFISH BALLS, FISH ROLLS STUFFED WITH FISH OR PORK FILLINGS; FRIED SHRIMP BALLS STUFFED WITH PORK FILLINGS; CHICKEN, BEEF AND VEGETABLES (U.S. CL. 46).

FIRST USE 7-15-2010; IN COMMERCE 7-15-2010.

**CLASS 30—STAPLE FOODS**

FOR MINI PORK BUNS; STEAMED PORK BUNS; STEAMED CHICKEN BUNS; STEAMED DIM SUM; WONTONS; FROZEN DUMPLINGS FILLED WITH PORK (U.S. CL. 46).

FIRST USE 7-15-2010; IN COMMERCE 7-15-2010.  
PRISCILLA MILTON, EXAMINING ATTORNEY

**CLASS 25—CLOTHING**

FOR WEARING APPAREL, NAMELY, WARM-UP SUITS, SWEATSHIRTS, TEE-SHIRTS; MUSCLE SHIRTS; SPORTS SHIRTS; TANK TOPS; BATHING SUITS; BEACH WEAR; JOGGING SUITS; SHORTS; SHIRTS; GLOVES; UNDERWEAR; JERSEYS; HEADWEAR; FOOTWEAR, BELTS, SOCKS, HATS; CAPS; WORKOUT AND SPORTS APPAREL, NAMELY, SHORTS AND SHIRTS (U.S. CLS. 22 AND 39).

**CLASS 28—TOYS AND SPORTING GOODS**

FOR MARTIAL ARTS GLOVES; KARATE GLOVES; WRESTLING GLOVES; BOXING GLOVES, SPORTS EQUIPMENT FOR BOXING AND MARTIAL ARTS, NAMELY, JUMP ROPES, FREE EXERCISE WEIGHTS, PUNCHING BAGS, ABDOMINAL PROTECTOR, CHEST PROTECTORS, PUNCHING BAG STANDS, SPEED BAGS (U.S. CLS. 22, 23, 38 AND 50).

SARA BENJAMIN, EXAMINING ATTORNEY

SN 85-093,067. SEARS BRANDS, LLC, HOFFMAN ESTATES, IL. FILED 7-26-2010.

SR<sup>3</sup>

THE MARK CONSISTS OF THE LETTERS "SR" WITH A SUPERSCRIPIT "3" NEXT TO THE "R".

**CLASS 35—ADVERTISING AND BUSINESS**

FOR RETAIL DEPARTMENT STORE SERVICES; OPERATING MARKETPLACES LOCATED WITHIN A RETAIL DEPARTMENT STORE FEATURING BOUTIQUE RETAIL SHOPS, POP-UP STORES AND STORE FRONTS FOR SERVICE PROVIDERS OPERATED BY THIRD PARTY MERCHANTS; BUSINESS MANAGEMENT AND CONSULTING SERVICES FOR THE ESTABLISHMENT AND OPERATION OF BOUTIQUE RETAIL STORES, POP-UP STORES AND STORE FRONTS FOR SERVICE PROVIDERS, NAMELY, CUSTOMER SERVICE, ACCOUNTING SERVICES, MARKETING SERVICES, INVENTORY CONTROL, MANAGING LOGISTICS AND ORDER FULFILLMENT SERVICES; OPERATING A WAREHOUSE FACILITY CONTAINING MAIL ORDER OR DISTRIBUTION INVENTORY (U.S. CLS. 100, 101 AND 102).

**CLASS 36—INSURANCE AND FINANCIAL**

FOR RENTAL AND LEASING OF SPACE IN A RETAIL STORE TO THIRD PARTY MERCHANTS FOR THE PURPOSE OF OPERATING BOUTIQUE RETAIL SHOPS, POP-UP STORES AND SERVICE PROVIDER STORE FRONTS; REAL ESTATE SERVICES, NAMELY, LEASING AND MANAGEMENT FOR OTHERS OF SPACE IN MARKETPLACES FOR SELLERS OF GOODS AND/OR SERVICES LOCATED WITHIN A RETAIL DEPARTMENT STORE (U.S. CLS. 100, 101 AND 102).  
ALLISON SCHRODY, EXAMINING ATTORNEY

SN 85-094,723. THE ESTATE OF WILLARD MULLIN, LLC, SACRAMENTO, CA. FILED 7-28-2010.

**THE BROOKLYN BUM**

THE MARK CONSISTS OF STANDARD CHARACTERS WITHOUT CLAIM TO ANY PARTICULAR FONT, STYLE, SIZE, OR COLOR.

THE NAME(S), PORTRAIT(S), AND/OR SIGNATURE(S) SHOWN IN THE MARK DOES NOT IDENTIFY A PARTICULAR LIVING INDIVIDUAL.

SN 85-094,125. COUPER AND PARTNERS LIMITED, LONDON, UNITED KINGDOM, FILED 7-27-2010.

**COUPER****CLASS 16—PAPER GOODS AND PRINTED MATTER**

FOR PAPER GOODS AND PRODUCTS CONSISTING OF WRITING TABLETS, GREETING CARDS, STATIONERY, AND CALENDARS; PENCILS, PENS AND COASTERS MADE OF PAPER (U.S. CLS. 2, 5, 22, 23, 29, 37, 38 AND 50).

**CLASS 25—CLOTHING**

FOR CLOTHING, NAMELY, SWEAT SHIRTS, T-SHIRTS, SPORTS UNIFORMS, HATS, AND JACKETS (U.S. CLS. 22 AND 39).

SUSAN LESLIE DUBOIS, EXAMINING ATTORNEY

THE MARK CONSISTS OF STANDARD CHARACTERS WITHOUT CLAIM TO ANY PARTICULAR FONT, STYLE, SIZE, OR COLOR.

PRIORITY CLAIMED UNDER SEC. 44(D) ON UNITED KINGDOM APPLICATION NO. 2553256, FILED 7-19-2010, REG. NO. 2553256, DATED 10-15-2010, EXPIRES 7-19-2020.

THE ENGLISH TRANSLATION OF "COUPER" IN THE MARK IS TO "CUT".

SN 85-094,746. THE ESTATE OF WILLARD MULLIN, LLC, SACRAMENTO, CA. FILED 7-28-2010.

**CLASS 35—ADVERTISING AND BUSINESS**

FOR BUSINESS MARKETING CONSULTATION SERVICES; ADVERTISING AGENCY SERVICES; CONDUCTING BUSINESS AND MARKETING RESEARCH SURVEYS; SERVICES RELATING TO THE ANALYSIS, EVALUATION, CREATION AND BRAND ESTABLISHMENT OF TRADEMARKS, TRADE NAMES, LOGOS, CORPORATE IDENTITIES, AND DOMAIN NAMES; BUSINESS MANAGEMENT SERVICES IN THE FIELD OF BRAND NAMES, NAMELY, BRAND EVALUATION, BRAND POSITIONING, BRAND STRATEGY, AND CONSULTATION SERVICES RELATED THERETO; ADVERTISING AND PUBLICITY SERVICES, NAMELY, PROMOTING THE GOODS, SERVICES, BRAND IDENTITY AND COMMERCIAL INFORMATION AND NEWS OF THIRD PARTIES THROUGH PRINT, AUDIO, VIDEO, DIGITAL AND ON-LINE MEDIA; BUSINESS MARKETING CONSULTATION AND DESIGN OF ADVERTISING MATERIALS FOR OTHERS IN THE FIELDS OF BRAND NAMES, LOGOS, AND CORPORATE IDENTITIES (U.S. CLS. 100, 101 AND 102).

**WILLARD MULLIN**

THE MARK CONSISTS OF STANDARD CHARACTERS WITHOUT CLAIM TO ANY PARTICULAR FONT, STYLE, SIZE, OR COLOR.

THE NAME(S), PORTRAIT(S), AND/OR SIGNATURE(S) SHOWN IN THE MARK DOES NOT IDENTIFY A PARTICULAR LIVING INDIVIDUAL.

**CLASS 42—SCIENTIFIC AND COMPUTER SERVICES**

FOR CONSULTATION AND DESIGN SERVICES FOR OTHERS IN THE FIELDS OF PACKAGE DESIGN, GRAPHIC DESIGN OF BUSINESS STATIONERY AND PROMOTIONAL MATERIALS; INTERIOR DESIGN OF RETAIL SPACE, RETAIL KIOSKS AND INTERACTIVE MEDIA SPACE FOR OTHERS; PRODUCT RESEARCH AND DEVELOPMENT; DESIGN OF WEBSITES FOR OTHERS (U.S. CLS. 100 AND 101).

REBECCA GILBERT, EXAMINING ATTORNEY

**CLASS 16—PAPER GOODS AND PRINTED MATTER**

FOR PAPER GOODS AND PRODUCTS CONSISTING OF WRITING TABLETS, GREETING CARDS, STATIONERY, AND CALENDARS; PENCILS, PENS AND COASTERS MADE OF PAPER (U.S. CLS. 2, 5, 22, 23, 29, 37, 38 AND 50).

**CLASS 25—CLOTHING**

FOR CLOTHING, NAMELY, SWEAT SHIRTS, T-SHIRTS, SPORTS UNIFORMS, HATS, AND JACKETS (U.S. CLS. 22 AND 39).

SUSAN LESLIE DUBOIS, EXAMINING ATTORNEY

SN 85-095,049. ZFS LICENSING, INC., ZEELAND, MI. FILED 7-28-2010.

# ZFSOYA

THE MARK CONSISTS OF STANDARD CHARACTERS WITHOUT CLAIM TO ANY PARTICULAR FONT, STYLE, SIZE, OR COLOR.

OWNER OF U.S. REG. NOS. 3,685,067, 3,697,626 AND 3,822,305.

## CLASS 29—MEATS AND PROCESSED FOODS

FOR SOYBEAN OIL; SOYBEAN MEAL AND SOYBEAN HULLS FOR USE IN HUMAN CONSUMPTION AS A FOOD ADDITIVE (U.S. CL. 46).

FIRST USE 7-0-1996; IN COMMERCE 7-0-1996.

## CLASS 31—NATURAL AGRICULTURAL PRODUCTS

FOR SOYBEAN MEAL AND SOYBEAN HULLS FOR USE AS ANIMAL FEED (U.S. CLS. 1 AND 46).

FIRST USE 7-0-1996; IN COMMERCE 7-0-1996.

## CLASS 40—MATERIAL TREATMENT

FOR SOYBEAN PROCESSING (U.S. CLS. 100, 103 AND 106).

FIRST USE 7-0-1996; IN COMMERCE 7-0-1996.

JULIE WATSON, EXAMINING ATTORNEY

SN 85-095,256. RU OUTSIDE THE BOX?, LLC, RICHMOND, RI. FILED 7-28-2010.



THE MARK CONSISTS OF A STYLIZED PAINT SPATTER IMAGE WITH A SQUARE AREA INSIDE THE SPATTER.

## CLASS 10—MEDICAL APPARATUS

FOR BABY BOTTLES MADE OF STAINLESS STEEL SOLD EMPTY (U.S. CLS. 26, 39 AND 44).

## CLASS 18—LEATHER GOODS

FOR BACK PACKS AND TOTE BAGS (U.S. CLS. 1, 2, 3, 22 AND 41).

## CLASS 21—HOUSEWARES AND GLASS

FOR REUSEABLE STAINLESS STEEL WATER BOTTLES SOLD EMPTY (U.S. CLS. 2, 13, 23, 29, 30, 33, 40 AND 50).

## CLASS 24—FABRICS

FOR TOWELS; BED BLANKETS (U.S. CLS. 42 AND 50).

## CLASS 25—CLOTHING

FOR GLOVES, HATS, SCARVES, SHIRTS, SWEAT SHIRTS, ONE PIECE GARMENTS FOR INFANTS AND TODDLERS, PANTS, SHORTS, SOCKS (U.S. CLS. 22 AND 39).

DAVID TOOLEY, EXAMINING ATTORNEY

SN 85-095,872. LISTEN LLC, CHICAGO, IL. FILED 7-29-2010.

# EAR TO THE GROUND IDEAS

THE MARK CONSISTS OF STANDARD CHARACTERS WITHOUT CLAIM TO ANY PARTICULAR FONT, STYLE, SIZE, OR COLOR.

## CLASS 35—ADVERTISING AND BUSINESS

FOR BUSINESS CONSULTING SERVICES, NAMELY, PROVIDING ASSISTANCE IN DEVELOPMENT OF BUSINESS STRATEGIES AND MARKETING, AND BUSINESS RESEARCH SERVICES; PROVIDING CONSULTING SERVICES IN THE NATURE OF DEVELOPMENT OF BUSINESS STRATEGIES AND MARKETING TO ENTREPRENEURS (U.S. CLS. 100, 101 AND 102).

## CLASS 36—INSURANCE AND FINANCIAL

FOR INVESTMENT CONSULTING SERVICES, NAMELY, CAPITAL INVESTMENT CONSULTING; PROVIDING FINANCIAL SUPPORT TO ENTREPRENEURS (U.S. CLS. 100, 101 AND 102).

NAKWAMA ANKRAH, EXAMINING ATTORNEY

SN 85-097,123. GULF COAST NUTRITIONALS, INC., NAPLES, FL. FILED 7-30-2010.

# NO STAINS FUR ME

THE MARK CONSISTS OF STANDARD CHARACTERS WITHOUT CLAIM TO ANY PARTICULAR FONT, STYLE, SIZE, OR COLOR.

**CLASS 3—COSMETICS AND CLEANING PREPARATIONS**

FOR NON-MEDICATED GROOMING PREPARATIONS FOR DOG, CATS, PETS, AND DOMESTICATED ANIMALS, NAMELY, SHAMPOO, SPRAYS AND OINTMENTS; PET TEAR STAIN REMOVER; PET PRODUCTS FOR COSMETIC PURPOSES, NAMELY, PET FRAGRANCES, ODOR REMOVERS AND SHAMPOO (U.S. CLS. 1, 4, 6, 50, 51 AND 52).

**CLASS 5—PHARMACEUTICALS**

FOR NUTRITIONAL SUPPLEMENTS FOR PETS; NUTRITIONAL SUPPLEMENTS FOR PETS FOR MEDICAL AND GROOMING PURPOSES, NAMELY, MEDICATED GROOMING PREPARATIONS FOR PETS, NAMELY, SHAMPOOS, SPRAYS AND OINTMENTS (U.S. CLS. 6, 18, 44, 46, 51 AND 52).

PAUL MORENO, EXAMINING ATTORNEY

SN 85-097,529. THE UNIVERSAL CHURCH, NEWARK, NJ. FILED 7-31-2010.



THE COLOR(S) YELLOW, ORANGE, AND BLACK IS/ ARE CLAIMED AS A FEATURE OF THE MARK.

THE MARK CONSISTS OF THE LETTER "D" OUTLINED IN YELLOW AND ENGLUFED IN ORANGE FLAMES SET AGAINST A BLACK SQUARE SHAPED BACKGROUND.

**CLASS 16—PAPER GOODS AND PRINTED MATTER**

FOR INFORMATIONAL BROCHURES ALL ABOUT RELIGIOUS BELIEFS AND PRACTICES; RELIGIOUS CIRCULAR NOTE CARDS (U.S. CLS. 2, 5, 22, 23, 29, 37, 38 AND 50).

FIRST USE 8-1-2009; IN COMMERCE 8-1-2009.

**CLASS 25—CLOTHING**

FOR T-SHIRTS DISTRIBUTED IN CONNECTION WITH A RELIGIOUS GROUP (U.S. CLS. 22 AND 39).

FIRST USE 8-1-2009; IN COMMERCE 8-1-2009.

**CLASS 45—PERSONAL AND LEGAL SERVICES**

FOR RELIGIOUS COUNSELING SERVICES AND MINISTERIAL SERVICES; RELIGIOUS AND SPIRITUAL SERVICES, NAMELY, PROVIDING GATHERINGS AND RETREATS TO DEVELOP AND ENHANCE THE SPIRITUAL LIVES OF INDIVIDUALS (U.S. CLS. 100 AND 101).

FIRST USE 8-1-2009; IN COMMERCE 8-1-2009.  
RUSS HERMAN, EXAMINING ATTORNEY

SN 85-097,890. ROYAL PARTY CORP., PASADENA, CA. FILED 8-2-2010.

THE NAME(S), PORTRAIT(S), AND/OR SIGNATURE(S) SHOWN IN THE MARK IDENTIFIES "KELLY ZHANG", WHOSE CONSENT(S) TO REGISTER IS MADE OF RECORD.

THE MARK CONSISTS OF THE STYLIZED WORDING "KELLY ZHANG" WITH A STYLIZED HEART DESIGN AS PART OF THE LETTER "K".

**CLASS 3—COSMETICS AND CLEANING PREPARATIONS**

FOR EYE SHADOW; FALSE EYELASHES; FOUNDATION (U.S. CLS. 1, 4, 6, 50, 51 AND 52).

FIRST USE 3-1-2008; IN COMMERCE 3-1-2008.

**CLASS 21—HOUSEWARES AND GLASS**

FOR MAKE-UP BRUSHES (U.S. CLS. 2, 13, 23, 29, 30, 33, 40 AND 50).

FIRST USE 3-1-2008; IN COMMERCE 3-1-2008.

**CLASS 44—MEDICAL, BEAUTY AND AGRICULTURAL SERVICES**

FOR PROVIDING ON-SITE BEAUTY SERVICES, NAMELY, HAIR STYLING AND MAKE-UP APPLICATION SERVICES (U.S. CLS. 100 AND 101).

FIRST USE 3-1-2008; IN COMMERCE 3-1-2008.

WON TEAK OH, EXAMINING ATTORNEY

SN 85-098,364. GERSOVITZ, GERALD, SAN FRANCISCO, CA. FILED 8-2-2010.



NO CLAIM IS MADE TO THE EXCLUSIVE RIGHT TO USE "FRESH" AND "2 PACKAGES IN ONE", APART FROM THE MARK AS SHOWN.

THE MARK CONSISTS OF THE WORDS "STAY FRESH" AND "FLIP FRESH" ON AN OVAL FORMED BY TWO ARROWS, THE WORDS "2 PACKAGES IN ONE" IN THE MIDDLE OF THE OVAL.

**CLASS 3—COSMETICS AND CLEANING PREPARATIONS**

FOR PRE-MOISTENED COSMETIC TOWLETTES FOR PERSONAL CARE, HOUSEHOLD CLEANING PRODUCTS, NAMELY, CLEANING PREPARATIONS FOR HOUSEHOLD PURPOSES (U.S. CLS. 1, 4, 6, 50, 51 AND 52).

H. M. FISHER, EXAMINING ATTORNEY

SN 85-099,893. COMPONENTONE LLC, PITTSBURGH, PA. FILED 8-4-2010.

**CLASS 29—MEATS AND PROCESSED FOODS**

FOR MILK; COFFEE ADDITIVES, NAMELY, COFFEE CREAMER, ARTIFICIAL COFFEE CREAMER; DRIED FRUITS; FRUIT-BASED SNACK FOODS (U.S. CL. 46).

WIJMO

THE MARK CONSISTS OF STANDARD CHARACTERS WITHOUT CLAIM TO ANY PARTICULAR FONT, STYLE, SIZE, OR COLOR.

**CLASS 30—STAPLE FOODS**

FOR COFFEE, TEA, POWDERED COCOA AND ICED TEA MIXES, SALTED CEREAL-BASED SNACK FOODS, ICE CREAM, BREAD, BREAKFAST CEREAL (U.S. CL. 46).

**CLASS 9—ELECTRICAL AND SCIENTIFIC APPARATUS**

FOR COMPUTER SOFTWARE FOR THE DEVELOPMENT OF OTHER COMPUTER SOFTWARE APPLICATIONS AND WEB APPLICATIONS (U.S. CLS. 21, 23, 26, 36 AND 38).

FIRST USE 1-11-2011; IN COMMERCE 1-11-2011.

**CLASS 32—LIGHT BEVERAGES**

FOR FRUIT JUICES (U.S. CLS. 45, 46 AND 48).  
CYNTHIA SLOAN, EXAMINING ATTORNEY

SN 85-098,767. SOUNDCLLOUD LTD., BERLIN, FED REP GERMANY, FILED 8-3-2010.

SOUNDCLLOUD

**CLASS 42—SCIENTIFIC AND COMPUTER SERVICES**

FOR COMPUTER SOFTWARE SERVICES, NAMELY, TROUBLESHOOTING OF COMPUTER SOFTWARE PROBLEMS VIA A CALL IN HELP-DESK, ONLINE HELP-DESK AND VIA CHAT AND EMAILS (U.S. CLS. 100 AND 101).

FIRST USE 1-11-2011; IN COMMERCE 1-11-2011.  
COLLEEN KEARNEY, EXAMINING ATTORNEY

THE MARK CONSISTS OF STANDARD CHARACTERS WITHOUT CLAIM TO ANY PARTICULAR FONT, STYLE, SIZE, OR COLOR.

OWNER OF ERPN CMNTY TM OFC REG. NO. 8283137, DATED 3-16-2010, EXPIRES 5-6-2019.

SN 85-100,879. MEIJI SEIKA KAISHA, LTD., TOKYO, JAPAN, FILED 8-5-2010.

**CLASS 35—ADVERTISING AND BUSINESS**

FOR ADVERTISING SERVICES; ADVERTISING AND PROMOTION OF MUSIC AND ENTERTAINMENT PRODUCTS AND SERVICES; BUSINESS MANAGEMENT AND BUSINESS ADMINISTRATION SERVICES; ADVISORY AND CONSULTANCY SERVICES RELATING TO THE AFORESAID (U.S. CLS. 100, 101 AND 102).

**CLASS 38—COMMUNICATION**

FOR TELECOMMUNICATIONS SERVICES FOR PROVIDING MULTIPLE-USER ACCESS TO A GLOBAL COMPUTER NETWORK; ADVISORY AND CONSULTANCY SERVICES RELATING TO THE AFORESAID (U.S. CLS. 100, 101 AND 104).

**CLASS 41—EDUCATION AND ENTERTAINMENT**

FOR PRODUCTION AND DISTRIBUTION OF MUSIC VIDEOS (U.S. CLS. 100, 101 AND 107).

NO CLAIM IS MADE TO THE EXCLUSIVE RIGHT TO USE "AMINO COLLAGEN" AND THE NON-LATIN CHARACTERS THAT TRANSLITERATE TO "AMINOKORAGEN", APART FROM THE MARK AS SHOWN.

THE COLOR(S) PINK, WHITE AND A YELLOWISH HUE OF GREEN IS/ARE CLAIMED AS A FEATURE OF THE MARK.

THE MARK CONSISTS OF THE STYLIZED WORDS "AMINO COLLAGEN" IN THE COLOR PINK DIRECTLY ABOVE A PINK SQUARE WITH WHITE JAPANESE CHARACTERS IN THE INTERIOR, WITH A YELLOWISH HUE OF GREEN STYLIZED LETTER "A" PARTIALLY OVERLAPPING A PINK STYLIZED LETTER "C" IN THE BACKGROUND.

THE NON-LATIN CHARACTERS IN THE MARK TRANSLITERATE TO "AMINOKORAGEN" AND THIS MEANS "AMINO COLLAGEN" IN ENGLISH.

**CLASS 42—SCIENTIFIC AND COMPUTER SERVICES**

FOR DESIGN AND MAINTENANCE OF COMPUTER SOFTWARE; APPLICATION SERVICE PROVIDER, NAMELY, HOSTING COMPUTER SOFTWARE APPLICATIONS OF OTHERS; ADVISORY AND CONSULTANCY SERVICES RELATING TO THE AFORESAID (U.S. CLS. 100 AND 101).

**CLASS 5—PHARMACEUTICALS**

FOR PHARMACEUTICAL PRODUCT, NAMELY, A COLLAGEN BASED POWDER CONTAINING AMINO ACIDS FOR THE TREATMENT OF FACIAL WRINKLES (U.S. CLS. 6, 18, 44, 46, 51 AND 52).

FIRST USE 3-0-2002; IN COMMERCE 8-0-2006.

**CLASS 29—MEATS AND PROCESSED FOODS**

FOR FOOD ADDITIVES, NAMELY, NATURAL FOOD EXTRACTS DERIVED FROM FISH, FISH OIL, FISH PROTEIN, ALGAE, SEAWEED, FISH OR SHARK CARTILAGE, OR SEASHELLS NOT FOR MEDICINAL PURPOSES AND FOR HUMAN CONSUMPTION; PROTEIN FOR USE AS A FOOD ADDITIVE; PROTEIN FOR USE AS A FOOD FILLER; PROTEIN POWDERS FOR HUMAN CONSUMPTION FOR USE AS A FOOD ADDITIVE (U.S. CL. 46).

FIRST USE 3-0-2002; IN COMMERCE 8-0-2006.  
ASMAT KHAN, EXAMINING ATTORNEY

SN 85-102,884. EMULATE, CHAPMANSBORO, TN. FILED 8-9-2010.

## ULTRA EMU OIL

THE MARK CONSISTS OF STANDARD CHARACTERS WITHOUT CLAIM TO ANY PARTICULAR FONT, STYLE, SIZE, OR COLOR.

NO CLAIM IS MADE TO THE EXCLUSIVE RIGHT TO USE "EMU OIL", APART FROM THE MARK AS SHOWN. SEC. 2(F).

**CLASS 3—COSMETICS AND CLEANING PREPARATIONS**

FOR EMU OIL FOR COSMETIC PURPOSE (U.S. CLS. 1, 4, 6, 50, 51 AND 52).

FIRST USE 1-11-2005; IN COMMERCE 1-11-2005.

**CLASS 5—PHARMACEUTICALS**

FOR EMU OIL FOR USE IN PHARMACEUTICALS OR IN DIETARY SUPPLEMENTS (U.S. CLS. 6, 18, 44, 46, 51 AND 52).

FIRST USE 1-11-2005; IN COMMERCE 1-11-2005.  
DAWN FELDMAN, EXAMINING ATTORNEY

SN 85-103,584. TRUE DEFENSE, INC., ANAHEIM HILLS, CA. FILED 8-9-2010.

## TRUE DEFENSE

THE MARK CONSISTS OF STANDARD CHARACTERS WITHOUT CLAIM TO ANY PARTICULAR FONT, STYLE, SIZE, OR COLOR.

OWNER OF U.S. REG. NOS. 3,367,894 AND 3,618,641.

**CLASS 35—ADVERTISING AND BUSINESS**

FOR BUSINESS PROCESS CONSULTING, NAMELY, BUSINESS PROCESS IMPROVEMENT AND RE-ENGINEERING SERVICES; DISASTER RECOVERY SERVICES, NAMELY, BUSINESS CONTINUITY DESIGN AND DEPLOYMENT; BUSINESS INFORMATION TECHNOLOGY RISK MANAGEMENT; INFORMATION TECHNOLOGY CERTIFICATION COMPLIANCE, NAMELY, MONITORING AND TRACKING COMPUTING POLICIES TO ENSURE OBSERVANCE OF REQUIREMENTS PROMULGATED BY CERTIFYING ORGANIZATIONS (U.S. CLS. 100, 101 AND 102).

**CLASS 41—EDUCATION AND ENTERTAINMENT**

FOR TRAINING SERVICES IN THE FIELD OF INTERNET SECURITY (U.S. CLS. 100, 101 AND 107).

**CLASS 42—SCIENTIFIC AND COMPUTER SERVICES**

FOR INTERNET SECURITY SERVICES, NAMELY, MONITORING AND MANAGEMENT OF NETWORK SECURITY SOFTWARE AND HARDWARE; INTERNET SECURITY SERVICES, NAMELY, HOSTING MANAGEMENT SECURITY SOFTWARE OF OTHERS FOR MANAGING NETWORK SECURITY INFRASTRUCTURE; COMPUTER AUDIT SERVICES, NAMELY, INSPECTING AND TESTING NETWORK SECURITY SOFTWARE AND HARDWARE FOR VULNERABILITIES; COMPUTER AUDIT SERVICES, NAMELY, HOSTING COMPUTER SOFTWARE OF OTHERS FOR THE INSPECTION AND TESTING OF NETWORK SECURITY SOFTWARE; COMPUTER SERVICES, NAMELY, HOSTING SOFTWARE OF OTHERS FOR THE RECOVERY AND RESTORATION OF DATA; COMPUTER DISASTER RECOVERY SERVICES, NAMELY, RESTORING LOST DATA FOLLOWING A DISASTER; COMPUTER SERVICES, NAMELY, INTERNAL AND EXTERNAL INFORMATION TECHNOLOGY SECURITY ASSESSMENTS AND PLANNING, DESIGN AND MANAGEMENT OF INFORMATION TECHNOLOGY SYSTEMS (U.S. CLS. 100 AND 101).

JULIE VEPPUMTHARA, EXAMINING ATTORNEY

SN 85-103,604. TRUE DEFENSE, INC., ANAHEIM HILLS, CA. FILED 8-9-2010.



OWNER OF U.S. REG. NOS. 3,367,894 AND 3,618,641.  
THE COLOR(S) RED AND GREY IS/ARE CLAIMED AS A FEATURE OF THE MARK.

THE MARK CONSISTS OF A SHIELD DIVIDED IN HALF BY A VERTICAL LINE, THE LEFT HALF RED, THE RIGHT HALF GREY, THE SHIELD HAVING "TD" CENTERED, THE LETTERING "TD" REPRESENTS A TRANSPARENT AREA OF THE MARK, THE "T" ON THE LEFT HALF AND THE "D" ON THE RIGHT HALF, "TRUEDEFENSE" APPEARS IN RED BELOW THE SHIELD.

**CLASS 35—ADVERTISING AND BUSINESS**

FOR BUSINESS PROCESS CONSULTING, NAMELY, BUSINESS PROCESS IMPROVEMENT AND RE-ENGINEERING SERVICES; DISASTER RECOVERY SERVICES, NAMELY, BUSINESS CONTINUITY DESIGN AND DEPLOYMENT; BUSINESS INFORMATION TECHNOLOGY RISK MANAGEMENT; INFORMATION TECHNOLOGY CERTIFICATION COMPLIANCE, NAMELY, MONITORING AND TRACKING COMPUTING POLICIES TO ENSURE OBSERVANCE OF REQUIREMENTS PROMULGATED BY CERTIFYING ORGANIZATIONS (U.S. CLS. 100, 101 AND 102).

FIRST USE 1-18-2010; IN COMMERCE 1-18-2010.

**CLASS 41—EDUCATION AND ENTERTAINMENT**

FOR TRAINING SERVICES IN THE FIELD OF INTERNET SECURITY (U.S. CLS. 100, 101 AND 107).

FIRST USE 1-18-2010; IN COMMERCE 1-8-2010.

**CLASS 42—SCIENTIFIC AND COMPUTER SERVICES**

FOR INTERNET SECURITY SERVICES, NAMELY, MONITORING AND MANAGEMENT OF NETWORK SECURITY SOFTWARE AND HARDWARE; INTERNET SECURITY SERVICES, NAMELY, HOSTING MANAGEMENT SECURITY SOFTWARE OF OTHERS FOR MANAGING NETWORK SECURITY INFRASTRUCTURE; COMPUTER AUDIT SERVICES, NAMELY, INSPECTING AND TESTING NETWORK SECURITY SOFTWARE AND HARDWARE FOR VULNERABILITIES; COMPUTER AUDIT SERVICES, NAMELY, HOSTING COMPUTER SOFTWARE OF OTHERS FOR THE INSPECTION AND TESTING OF NETWORK SECURITY SOFTWARE; COMPUTER SERVICES, NAMELY, HOSTING SOFTWARE OF OTHERS FOR THE RECOVERY AND RESTORATION OF DATA; COMPUTER DISASTER RECOVERY SERVICES, NAMELY, RESTORING LOST DATA FOLLOWING A DISASTER; COMPUTER SERVICES, NAMELY, INTERNAL AND EXTERNAL INFORMATION TECHNOLOGY SECURITY ASSESSMENTS AND PLANNING, DESIGN AND MANAGEMENT OF INFORMATION TECHNOLOGY SYSTEMS (U.S. CLS. 100 AND 101).

JULIE VEPPIUMTHARA, EXAMINING ATTORNEY

SN 85-103,610. CISCO TECHNOLOGY, INC., SAN JOSE, CA. FILED 8-9-2010.

# CISCO I-PRIZE

THE MARK CONSISTS OF STANDARD CHARACTERS WITHOUT CLAIM TO ANY PARTICULAR FONT, STYLE, SIZE, OR COLOR.

OWNER OF U.S. REG. NOS. 3,070,991, 3,759,451 AND OTHERS.

**CLASS 35—ADVERTISING AND BUSINESS**

FOR PROVIDING AN INNOVATION PROGRAM IN THE FIELDS OF TECHNOLOGY AND BUSINESS, NAMELY, CONDUCTING AN AWARD PROGRAM TO PROMOTE IDEA GENERATION FOR THE PURPOSE OF PRODUCING BUSINESS IDEAS AND NEW TECHNOLOGY DEVELOPMENT FOR BUSINESSES (U.S. CLS. 100, 101 AND 102).

FIRST USE 11-1-2007; IN COMMERCE 11-1-2007.

**CLASS 41—EDUCATION AND ENTERTAINMENT**

FOR EDUCATIONAL AND ENTERTAINMENT SERVICES, NAMELY, ARRANGING AND CONDUCTING ONLINE SEMINARS IN THE FIELDS OF INNOVATION, BUSINESS AND TECHNOLOGY; PROVIDING AN INNOVATION PROGRAM IN THE FIELDS OF TECHNOLOGY AND BUSINESS, NAMELY, CONDUCTING AN AWARD PROGRAM TO PROMOTE IDEA GENERATION BY THE WAY OF AWARDS AND CONTESTS TO DEMONSTRATE EXCELLENCE IN THE FIELD OF NEW TECHNOLOGY DEVELOPMENT (U.S. CLS. 100, 101 AND 107).

FIRST USE 1-26-2010; IN COMMERCE 1-26-2010.  
DOMINIC FATHY, EXAMINING ATTORNEY

SN 85-103,621. REAL ESTATE IMAGE, INC., DBA ADVANCED IMAGE DIRECT, FULLERTON, CA. FILED 8-9-2010.

## REAL MAIL... EASY AS EMAIL

THE MARK CONSISTS OF STANDARD CHARACTERS WITHOUT CLAIM TO ANY PARTICULAR FONT, STYLE, SIZE, OR COLOR.

**CLASS 35—ADVERTISING AND BUSINESS**

FOR COMPUTERIZED ON-LINE RETAIL STORE SERVICES IN THE FIELD OF STATIONERY, POSTAGE, MISCELLANEOUS POSTAL PRODUCTS AND DOCUMENT DELIVERY PRODUCTS; INFORMATION MANAGEMENT SERVICES, NAMELY, SHIPMENT PROCESSING, PREPARING SHIPPING DOCUMENTS AND INVOICES, TRACKING DOCUMENTS, PACKAGES AND FREIGHT OVER COMPUTER NETWORKS, INTRANETS AND INTERNETS; MAIL SORTING, HANDLING AND RECEIVING; PROVIDING CONSUMER INFORMATION IN THE FIELD OF SHIPPING AND PACKAGE DELIVERY (U.S. CLS. 100, 101 AND 102).

FIRST USE 3-1-2009; IN COMMERCE 3-1-2009.

**CLASS 39—TRANSPORTATION AND STORAGE**

FOR DOCUMENT DELIVERY; ELECTRONIC DOCUMENT AND E-MAIL ARCHIVING SERVICES; FRANKING OF MAIL; SHIPPING AND DELIVERY SERVICES, NAMELY, PICKUP, TRANSPORTATION, AND DELIVERY OF PACKAGES AND LETTERS BY VARIOUS MODES OF TRANSPORTATION (U.S. CLS. 100 AND 105).

FIRST USE 3-1-2009; IN COMMERCE 3-1-2009.  
JEFF DEFORD, EXAMINING ATTORNEY

SN 85-103,624. CISCO TECHNOLOGY, INC., SAN JOSE, CA. FILED 8-9-2010.

# I-PRIZE

THE MARK CONSISTS OF STANDARD CHARACTERS WITHOUT CLAIM TO ANY PARTICULAR FONT, STYLE, SIZE, OR COLOR.

**CLASS 35—ADVERTISING AND BUSINESS**

FOR PROVIDING AN INNOVATION PROGRAM IN THE FIELDS OF TECHNOLOGY AND BUSINESS, NAMELY, CONDUCTING AN AWARD PROGRAM TO PROMOTE IDEA GENERATION FOR THE PURPOSE OF PRODUCING BUSINESS IDEAS AND NEW TECHNOLOGY DEVELOPMENT FOR BUSINESSES (U.S. CLS. 100, 101 AND 102).

**CLASS 41—EDUCATION AND ENTERTAINMENT**

FOR EDUCATIONAL AND ENTERTAINMENT SERVICES, NAMELY, ARRANGING AND CONDUCTING ONLINE SEMINARS IN THE FIELDS OF INNOVATION, BUSINESS AND TECHNOLOGY; PROVIDING AN INNOVATION PROGRAM IN THE FIELDS OF TECHNOLOGY AND BUSINESS, NAMELY, CONDUCTING AN AWARD PROGRAM TO PROMOTE IDEA GENERATION BY THE WAY OF AWARDS AND CONTESTS TO DEMONSTRATE EXCELLENCE IN THE FIELD OF NEW TECHNOLOGY DEVELOPMENT (U.S. CLS. 100, 101 AND 107).

DOMINIC FATHY, EXAMINING ATTORNEY

SN 85-104,399. CHAMPION LABORATORIES, INC., ALBION, IL. FILED 8-10-2010.

BUILT TO DO MORE

THE MARK CONSISTS OF STANDARD CHARACTERS WITHOUT CLAIM TO ANY PARTICULAR FONT, STYLE, SIZE, OR COLOR.

**CLASS 7—MACHINERY**

FOR OIL FILTERS; AIR FILTERS FOR MOTORS AND ENGINES; FUEL FILTERS; HYDRAULIC FILTERS FOR CHASSIS ON VEHICLES AND STATIONARY EQUIPMENT; HYDRAULIC FILTERS FOR INDUSTRIAL PRESSES AND COMPRESSORS; FILTERS FOR INTERNAL COMBUSTION ENGINES FOR NON-LAND VEHICLES AND INDUSTRIAL MACHINERY, NAMELY, OIL FILTERS, AIR FILTERS, HYDRAULIC FILTERS AND WATER FILTERS; FILTERS FOR INTERNAL COMBUSTION ENGINES FOR LAND VEHICLES, NAMELY, OIL FILTERS, WATER FILTERS, TRANSMISSION FILTERS, HYDRAULIC FILTERS, AND FUEL FILTERS; COOLANT FILTERS FOR MOTORS AND ENGINES; LIQUID REFINERS, NAMELY, OIL FILTERS FOR USE IN REFINING LUBRICATING OIL AND FOR BULK FILTRATION (U.S. CLS. 13, 19, 21, 23, 31, 34 AND 35).

**CLASS 11—ENVIRONMENTAL CONTROL APPARATUS**

FOR WATER FILTERS; CABIN AIR FILTERS FOR VEHICLES; LIQUID REFINERS, NAMELY, OIL PURIFYING INSTALLATIONS FOR USE IN REFINING LUBRICATING OIL AND FOR BULK FILTRATION (U.S. CLS. 13, 21, 23, 31 AND 34).

JAMES LOVELACE, EXAMINING ATTORNEY

SN 85-104,410. CHAMPION LABORATORIES, INC., ALBION, IL. FILED 8-10-2010.

**LUBER FINER**

OWNER OF U.S. REG. NOS. 897,773, 1,163,433 AND 3,152,650.

THE MARK CONSISTS OF THE TEXT "LUBER" ADJACENT TO A DROPLET FOLLOWED BY THE TEXT "FINER".

**CLASS 7—MACHINERY**

FOR OIL FILTERS; AIR FILTERS FOR MOTORS AND ENGINES; FUEL FILTERS; HYDRAULIC FILTERS FOR CHASSIS ON VEHICLES AND STATIONARY EQUIPMENT; HYDRAULIC FILTERS FOR INDUSTRIAL PRESSES AND COMPRESSORS; FILTERS FOR INTERNAL COMBUSTION ENGINES FOR NON-LAND VEHICLES AND INDUSTRIAL MACHINERY, NAMELY, OIL FILTERS, AIR FILTERS, HYDRAULIC FILTERS AND WATER FILTERS; FILTERS FOR INTERNAL COMBUSTION ENGINES FOR LAND VEHICLES, NAMELY, OIL FILTERS, WATER FILTERS, TRANSMISSION FILTERS, HYDRAULIC FILTERS, AND FUEL FILTERS; COOLANT FILTERS FOR MOTORS AND ENGINES; LIQUID REFINERS, NAMELY, OIL FILTERS FOR USE IN REFINING LUBRICATING OIL AND FOR BULK FILTRATION (U.S. CLS. 13, 19, 21, 23, 31, 34 AND 35).

**CLASS 11—ENVIRONMENTAL CONTROL APPARATUS**

FOR WATER FILTERS; CABIN AIR FILTERS FOR VEHICLES; LIQUID REFINERS, NAMELY, OIL PURIFYING INSTALLATIONS FOR USE IN REFINING LUBRICATING OIL AND FOR BULK FILTRATION (U.S. CLS. 13, 21, 23, 31 AND 34).

JAMES LOVELACE, EXAMINING ATTORNEY

SN 85-105,945. EQUATORIAL GUINEA LNG COMPANY S.A., BOKO ISLAND, EQUATORIAL GUINEA, FILED 8-12-2010.



OWNER OF EQUATORIAL GUINEA REG. NO. O.A.P.I.5283, DATED 3-30-2006, EXPIRES 7-28-2015.

NO CLAIM IS MADE TO THE EXCLUSIVE RIGHT TO USE "LNG", APART FROM THE MARK AS SHOWN.

**CLASS 4—LUBRICANTS AND FUELS**

FOR NATURAL GAS AND PROCESSED NATURAL GAS PRODUCTS, NAMELY, LIQUIFIED NATURAL GAS, BUTANE, PROPANE AND CONDENSATE (U.S. CLS. 1, 6 AND 15).



**CLASS 39—TRANSPORTATION AND STORAGE**

FOR TRANSPORTATION AND STORAGE OF NATURAL GAS AND PROCESSED NATURAL GAS PRODUCTS, NAMELY LIQUIFIED NATURAL GAS, BUTANE, PROPANE AND CONDENSATE (U.S. CLS. 100 AND 105).

**CLASS 40—MATERIAL TREATMENT**

FOR PRODUCTION AND PROCESSING OF NATURAL GAS (U.S. CLS. 100, 103 AND 106).  
DEBRA LEE, EXAMINING ATTORNEY

SN 85-106,974. POLITISTREAM, INC., DAYTON, OH. FILED 8-13-2010.

**POLITISTREAM**

THE MARK CONSISTS OF STANDARD CHARACTERS WITHOUT CLAIM TO ANY PARTICULAR FONT, STYLE, SIZE, OR COLOR.

**CLASS 42—SCIENTIFIC AND COMPUTER SERVICES**

FOR PROVIDING AN ONLINE WEBSITE FEATURING NON-DOWNLOADABLE SOFTWARE TO ENABLE UP-LOADING, POSTING, SHOWING, DISPLAYING, TAGGING, BLOGGING, SHARING OR OTHERWISE PROVIDING ELECTRONIC MEDIA OR INFORMATION OVER THE INTERNET OR OTHER COMMUNICATIONS NETWORK (U.S. CLS. 100 AND 101).

**CLASS 45—PERSONAL AND LEGAL SERVICES**

FOR PROVIDING AN ONLINE SOCIAL NETWORKING WEBSITE WITH A FOCUS ON POLITICS (U.S. CLS. 100 AND 101).  
LINDA ESTRADA, EXAMINING ATTORNEY

SN 85-106,345. OTIS ELEVATOR COMPANY, FARMINGTON, CT. FILED 8-12-2010.



THE COLOR(S) BLUE AND GREEN IS/ARE CLAIMED AS A FEATURE OF THE MARK.

THE MARK CONSISTS OF DESIGN CONSISTING OF TWO TRIANGULAR DOT PATTERNS, ONE SET APPEARING AS A SHADOW. THE DOT PATTERNS TRANSITION IN COLOR FROM BLUE TO GREEN GOING LEFT TO RIGHT.

**CLASS 7—MACHINERY**

FOR ELEVATORS, ESCALATORS, MOVING WALKWAYS AND PARTS THEREOF (U.S. CLS. 13, 19, 21, 23, 31, 34 AND 35).

**CLASS 9—ELECTRICAL AND SCIENTIFIC APPARATUS**

FOR ELECTRONIC CONTROLS FOR USE WITH ELEVATORS, LIFTS, ESCALATORS, MOVING WALKWAYS AND RELATED CARRIERS (U.S. CLS. 21, 23, 26, 36 AND 38).

**CLASS 37—CONSTRUCTION AND REPAIR**

FOR INSTALLATION, MAINTENANCE AND REPAIR OF ELEVATORS, LIFTS, ESCALATORS, MOVING WALKWAYS AND RELATED CARRIERS AND PARTS THEREOF (U.S. CLS. 100, 103 AND 106).

**CLASS 42—SCIENTIFIC AND COMPUTER SERVICES**

FOR MONITORING ELEVATORS, ESCALATORS, RELATED CARRIER PERFORMANCE AND DIAGNOSING ELEVATOR, ESCALATORS AND RELATED CARRIER PERFORMANCE PROBLEMS UTILIZING ELECTRONIC EQUIPMENT (U.S. CLS. 100 AND 101).  
NAAKWAMA ANKRAH, EXAMINING ATTORNEY

SN 85-106,982. CITY OF LONG BEACH, LONG BEACH, CA. FILED 8-13-2010.



OWNER OF U.S. REG. NOS. 2,341,577, 2,432,514 AND 2,670,988.

THE MARK CONSISTS OF THE TERMS "THE QUEEN MARY" BELOW A DESIGN OF A SHIP SMOKE STACK.

**CLASS 35—ADVERTISING AND BUSINESS**

FOR SPECIAL EVENT PLANNING COORDINATION AND CONSULTATION FOR BUSINESS PURPOSES FOR EVENTS TO BE HELD ON A PERMANENTLY MOORED SHIP NAMED THE "QUEEN MARY" (U.S. CLS. 100, 101 AND 102).  
FIRST USE 9-0-2009; IN COMMERCE 9-0-2009.

**CLASS 39—TRANSPORTATION AND STORAGE**

FOR CONDUCTING SIGHTSEEING TOURS, FOR OTHERS, ON A PERMANENTLY MOORED SHIP NAMED THE "QUEEN MARY" (U.S. CLS. 100 AND 105).  
FIRST USE 9-0-2009; IN COMMERCE 9-0-2009.

**CLASS 41—EDUCATION AND ENTERTAINMENT**

FOR SPECIAL EVENT, PARTY AND WEDDING PLANNING, COORDINATION AND CONSULTATION SERVICES FOR SOCIAL ENTERTAINMENT PURPOSES FOR EVENTS TO BE HELD ON A PERMANENTLY MOORED SHIP NAMED THE "QUEEN MARY" (U.S. CLS. 100, 101 AND 107).

FIRST USE 9-0-2009; IN COMMERCE 9-0-2009.

**CLASS 43—HOTEL AND RESTAURANT SERVICES**

FOR HOTEL AND RESTAURANT SERVICES, PROVIDING BANQUET AND SOCIAL FUNCTION FACILITIES FOR SPECIAL OCCASIONS ON A PERMANENTLY MOORED SHIP NAMED THE "QUEEN MARY" (U.S. CLS. 100 AND 101).

FIRST USE 9-0-2009; IN COMMERCE 9-0-2009.

**CLASS 45—PERSONAL AND LEGAL SERVICES**

FOR WEDDING CHAPEL SERVICES TO BE CONDUCTED ON A PERMANENTLY MOORED SHIP NAMED THE "QUEEN MARY" (U.S. CLS. 100 AND 101).

FIRST USE 9-0-2009; IN COMMERCE 9-0-2009.

TRICIA SONNEBORN, EXAMINING ATTORNEY

SN 85-108,243. AMERICAN CANCER SOCIETY, INC., ATLANTA, GA. FILED 8-16-2010.



OWNER OF U.S. REG. NO. 3,710,249.  
THE MARK CONSISTS OF A STYLIZED SWORD SIMULATING A CANDLE IN THE PLACE OF THE BLADE, WITH AN OPEN FLAME, AND A HANDLE CONSISTING OF CURVED LINES SUGGESTIVE OF A CADUCEUS SYMBOL.

**CLASS 35—ADVERTISING AND BUSINESS**

FOR PROMOTING PUBLIC AWARENESS OF CANCER RESEARCH, PREVENTION, DETECTION, AND TREATMENT (U.S. CLS. 100, 101 AND 102).

**CLASS 36—INSURANCE AND FINANCIAL**

FOR CHARITABLE FUNDRAISING SERVICES TO SUPPORT CANCER RESEARCH, EDUCATION, ADVOCACY, PREVENTION, DETECTION, TREATMENT, AND PATIENT AND FAMILY SERVICES (U.S. CLS. 100, 101 AND 102).

GISELLE AGOSTO, EXAMINING ATTORNEY

SN 85-108,770. SKABOOSH.COM, INC., SAN RAMON, CA. FILED 8-16-2010.

# Skaboosh

THE MARK CONSISTS OF STANDARD CHARACTERS WITHOUT CLAIM TO ANY PARTICULAR FONT, STYLE, SIZE, OR COLOR.

**CLASS 35—ADVERTISING AND BUSINESS**

FOR PROMOTING RECREATION AND TOURISM IN THE UNITED STATES (U.S. CLS. 100, 101 AND 102).

FIRST USE 11-1-2008; IN COMMERCE 4-1-2010.

**CLASS 41—EDUCATION AND ENTERTAINMENT**

FOR ENTERTAINMENT SERVICES, NAMELY, PROVIDING VIRTUAL ENVIRONMENTS IN WHICH USERS CAN INTERACT FOR RECREATIONAL, LEISURE OR ENTERTAINMENT PURPOSES; PROVIDING INFORMATION, NEWS AND COMMENTARY IN THE FIELD OF RECREATION AND LEISURE ACTIVITIES (U.S. CLS. 100, 101 AND 107).

FIRST USE 11-1-2008; IN COMMERCE 4-1-2010.

BENJAMIN OKEKE, EXAMINING ATTORNEY

SN 85-109,046. PROMETHEAN LTD, BLACKBURN, LANCA-SHIRE, UNITED KINGDOM, FILED 8-17-2010.

## PROMETHEAN ACTIVCARE

THE MARK CONSISTS OF STANDARD CHARACTERS WITHOUT CLAIM TO ANY PARTICULAR FONT, STYLE, SIZE, OR COLOR.

OWNER OF UNITED KINGDOM REG. NO. 2539470, DATED 6-25-2010, EXPIRES 2-17-2020.

**CLASS 9—ELECTRICAL AND SCIENTIFIC APPARATUS**

FOR WIRELESS TELEPHONES AND WIRELESS RADIO RECEIVERS; ELECTRONIC APPARATUS AND INSTRUMENTS FOR USE IN TEACHING, AND PERSONAL COMPUTING EQUIPMENT FOR USE THEREWITH, NAMELY, COMPUTERS, KEYBOARDS, INTERACTIVE ELECTRONIC WHITE BOARDS AND ASSOCIATED ELECTRONIC PENS AND PADS AND HANDHELD TRANSMITTERS AND RECEIVERS OF DATA; AUDIOVISUAL RECEIVERS AND TELEVISION TRANSMITTERS; FLAT PANEL DISPLAY SCREENS; TABLET COMPUTERS; COMPUTER MONITORS; COMPUTER HARDWARE AND PERIPHERALS THEREFOR; COMPUTER KEYPADS; ELECTRONIC INPUT DEVICES FOR USE WITH COMPUTERS AND INPUT DEVICES FOR USE WITH INTERACTIVE TEACHING APPARATUS, NAMELY, SCANNERS; COMPUTER PROGRAMS AND COMPUTER SOFTWARE FOR DATA PROCESSING; EDUCATIONAL SOFTWARE IN THE FIELD OF CHILD EDUCATION; EDUCATIONAL SOFTWARE IN THE FIELDS OF CURRICULUM BASED SUBJECT MATTERS FOR KINDERGARTEN THROUGH 12TH GRADE, CURRICULUM BASED SUBJECT MATTERS FOR ADULTS WHO HAVE NOT COMPLETED KINDERGARTEN THROUGH 12TH GRADE, AND CURRICULUM BASED SUBJECT MATTERS AT THE UNIVERSITY

LEVEL, NAMELY, LIBERAL ARTS, HUMANITIES, GEOGRAPHY, GEOLOGY, HISTORY, MATHEMATICS, ARTS, SCIENCES, LANGUAGES, LITERATURE, THEOLOGY, PHILOSOPHY, LAW, ENGINEERING, ECONOMICS, SOCIOLOGY, ARCHAEOLOGY, ANTHROPOLOGY, ECOLOGY, MEDICINE, NURSING, PSYCHOLOGY, ASTRONOMY, CULTURAL STUDIES, MEDIA STUDIES, ENVIRONMENTAL STUDIES, ARCHITECTURE, MUSIC, ACCOUNTING, INFORMATION TECHNOLOGY, BUSINESS STUDIES, TEACHING, TRAINING, EDUCATION, AND PHOTOGRAPHY; DIGITAL MOVIE PROJECTORS; VIDEO CONFERENCING APPARATUS, NAMELY, VIDEO CAMERAS; DATABASE MANAGEMENT SOFTWARE FOR GENERAL USE; DOWNLOADABLE PUBLICATIONS IN THE NATURE OF NEWSLETTERS IN THE FIELD OF EDUCATION, LEARNING, TEACHING, TEACHING STRATEGIES, FEEDBACK ASSESSMENT; DOWNLOADABLE PUBLICATIONS IN THE NATURE OF EDUCATIONAL AND TEACHING MATERIALS IN THE FIELDS OF CURRICULUM BASED SUBJECT MATTERS FOR KINDERGARTEN THROUGH 12TH GRADE, CURRICULUM BASED SUBJECT MATTERS FOR ADULTS WHO HAVE NOT COMPLETED KINDERGARTEN THROUGH 12TH GRADE, AND CURRICULUM BASED SUBJECT MATTERS AT THE UNIVERSITY LEVEL, NAMELY, LIBERAL ARTS, HUMANITIES, GEOGRAPHY, GEOLOGY, HISTORY, MATHEMATICS, ARTS, SCIENCES, LANGUAGES, LITERATURE, THEOLOGY, PHILOSOPHY, LAW, ENGINEERING, ECONOMICS, SOCIOLOGY, ARCHAEOLOGY, ANTHROPOLOGY, ECOLOGY, MEDICINE, NURSING, PSYCHOLOGY, ASTRONOMY, CULTURAL STUDIES, MEDIA STUDIES, ENVIRONMENTAL STUDIES, ARCHITECTURE, MUSIC, ACCOUNTING, INFORMATION TECHNOLOGY, BUSINESS STUDIES, TEACHING, TRAINING, EDUCATION, AND PHOTOGRAPHY AND LESSON PLANS AND RECOMMENDATIONS AND STRATEGIES FOR USING EDUCATION TECHNOLOGIES MOST EFFECTIVELY; BLANK DISCS FOR COMPUTERS, BLANK CASSETTE TAPES, VIDEO GAME CARTRIDGES AND BLANK MAGNETIC MEMORY AND DATA CARRIERS; PRE-RECORDED MAGNETIC MEMORY CARRIERS AND PRE-RECORDED MAGNETIC DATA CARRIERS BEARING EDUCATIONAL MATERIAL OR MATERIAL FOR LEARNING IN THE FIELDS OF CURRICULUM BASED SUBJECT MATTERS FOR KINDERGARTEN THROUGH 12TH GRADE, CURRICULUM BASED SUBJECT MATTERS FOR ADULTS WHO HAVE NOT COMPLETED KINDERGARTEN THROUGH 12TH GRADE, AND CURRICULUM BASED SUBJECT MATTERS AT THE UNIVERSITY LEVEL, NAMELY, LIBERAL ARTS, HUMANITIES, GEOGRAPHY, GEOLOGY, HISTORY, MATHEMATICS, ARTS, SCIENCES, LANGUAGES, LITERATURE, THEOLOGY, PHILOSOPHY, LAW, ENGINEERING, ECONOMICS, SOCIOLOGY, ARCHAEOLOGY, ANTHROPOLOGY, ECOLOGY, MEDICINE, NURSING, PSYCHOLOGY, ASTRONOMY, CULTURAL STUDIES, MEDIA STUDIES, ENVIRONMENTAL STUDIES, ARCHITECTURE, MUSIC, ACCOUNTING, INFORMATION TECHNOLOGY, BUSINESS STUDIES, TEACHING, TRAINING, EDUCATION, AND PHOTOGRAPHY; DOWNLOADABLE PUBLICATIONS IN THE NATURE OF EDUCATIONAL AND TEACHING MATERIALS FEATURING LESSON PLANS AND RECOMMENDATIONS AND STRATEGIES FOR USING EDUCATION TECHNOLOGIES MOST EFFECTIVELY; PRE-RECORDED MAGNETIC DATA CARRIERS BEARING LESSON PLANS AND RECOMMENDATIONS AND STRATEGIES FOR USING EDUCATION TECHNOLOGIES MOST EFFECTIVELY, PARTS AND FITTINGS FOR ALL THE AFORESAID GOODS (U.S. CLS. 21, 23, 26, 36 AND 38).

#### **CLASS 16—PAPER GOODS AND PRINTED MATTER**

FOR PRINTED MATTER, NAMELY, PUBLICATIONS, NAMELY, NEWSLETTERS, MAGAZINES, JOURNALS, BOOKS, BROCHURES, MANUALS, BOOKLETS, PAMPHLETS, PERIODICAL PUBLICATIONS, INSTRUCTIONAL AND TEACHING MATERIALS AND TEXTBOOKS IN THE FIELD OF TEACHING, TRAINING AND EDUCATION THROUGH INTERACTIVE TECHNOLOGIES AND THEIR USE; STATIONERY; PRINTED VISUALS IN THE NATURE OF PROMOTIONAL MATERIALS (U.S. CLS. 2, 5, 22, 23, 29, 37, 38 AND 50).

#### **CLASS 35—ADVERTISING AND BUSINESS**

FOR ADVERTISING; BUSINESS MANAGEMENT; BUSINESS ADMINISTRATION; OFFICE FUNCTIONS; RETAIL STORE SERVICES FEATURING EDUCATIONAL SOFTWARE, TEACHING APPARATUS AND INSTRUMENTS, PERIODICAL PUBLICATIONS, INSTRUCTIONAL AND TEACHING MATERIALS, STATIONERY; RETAIL STORE SERVICES FEATURING TEACHING APPARATUS AND INSTRUMENTS, ELECTRONIC APPARATUS FOR RECORDING, PROCESSING, STORAGE, INPUT OR OUTPUT OF IMAGES, DATA OR TEXT, RECEIVERS, TRANSMITTERS, INTERACTIVE TEACHING APPARATUS, DISPLAY APPARATUS, HARDWARE TABLETS, GRAPHIC TABLETS, COMPUTER MONITORS, COMPUTERS, COMPUTER HARDWARE AND PERIPHERALS THEREFOR, KEYPADS, ELECTRONIC PENS, ELECTRONIC INPUT DEVICES FOR USE WITH COMPUTERS, INPUT DEVICES FOR USE WITH INTERACTIVE TEACHING APPARATUS, COMPUTER PROGRAMMES, COMPUTER SOFTWARE, EDUCATIONAL SOFTWARE, DATABASES, DOWNLOADABLE PUBLICATIONS, DISCS, TAPES, CARTRIDGES, CASSETTES AND OTHER MEMORY OR DATA CARRIERS, PRERECORDED MEMORY CARRIERS, PRE-RECORDED DATA CARRIERS, PRE-RECORDED MEMORY CARRIERS BEARING EDUCATIONAL MATERIAL OR MATERIAL FOR LEARNING, PRE-RECORDED DATA CARRIERS BEARING EDUCATIONAL MATERIAL OR MATERIAL FOR LEARNING, AND PARTS AND FITTINGS FOR ALL THE AFORESAID GOODS; RETAIL STORE SERVICES FEATURING PRINTED MATTER, PUBLICATIONS, BOOKS, BROCHURES, MANUALS, BOOKLETS, PAMPHLETS, PERIODICAL PUBLICATIONS, INSTRUCTIONAL AND TEACHING MATERIALS, TEXTBOOKS, EDUCATIONAL MATERIALS, STATIONERY AND PROMOTIONAL MATERIALS (U.S. CLS. 100, 101 AND 102).

#### **CLASS 37—CONSTRUCTION AND REPAIR**

FOR INSTALLATION, MAINTENANCE AND REPAIR OF COMPUTERS AND ELECTRONIC TEACHING EQUIPMENT; INSTALLATION, MAINTENANCE AND REPAIR OF COMPUTER HARDWARE AND ELECTRONIC TEACHING EQUIPMENT AND APPARATUS; PROVISION OF INFORMATION AND ADVICE IN RELATION TO THE INSTALLATION, MAINTENANCE AND REPAIR OF COMPUTER HARDWARE AND ELECTRONIC TEACHING EQUIPMENTS AND APPARATUS (U.S. CLS. 100, 103 AND 106).

#### **CLASS 38—COMMUNICATION**

FOR TELECOMMUNICATIONS SERVICES, NAMELY, PROVIDING INTERNET CHAT ROOMS AND ONLINE USER FORUMS AND ONLINE DISCUSSION GROUPS FOR TRANSMISSION OF MESSAGES AMONG COMPUTER USERS CONCERNING A WIDE VARIETY OF INFORMATION AND TOPICS OF INTEREST TO THE GENERAL PUBLIC; PROVISION OF INFORMATION AND ADVICE IN RELATION TO ANY OF THE AFORESAID SERVICES (U.S. CLS. 100, 101 AND 104).

#### **CLASS 41—EDUCATION AND ENTERTAINMENT**

FOR EDUCATION SERVICES, NAMELY, TRAINING AND CONSULTATION SERVICES INCLUDING THE PROVISION OF ADVICE IN THE FIELDS OF TEACHING METHODS INCLUDING LEARNING AND KNOWLEDGE TRANSFER STRATEGIES; ARRANGING AND CONDUCTING EDUCATIONAL CONFERENCES; COMPUTER EDUCATION TRAINING SERVICES; RENTAL AND HIRE OF EDUCATIONAL AND INTERACTIVE TEACHING APPARATUS AND EQUIPMENT, NAMELY, VIDEO PROJECTION AND APPARATUS FOR USE IN RELATION TO WHITE BOARDS, PROJECTION AND DISPLAY SCREENS, ELECTRONIC TABLETS AND KEYPADS, ELECTRONIC PENS AND PADS, AND PERSONAL COMPUTING EQUIPMENT FOR USE THEREWITH; ARRANGING EDUCATIONAL EXHIBITIONS AND DEMONSTRATIONS; ARRANGING AND CONDUCTING SEMINARS AND WORKSHOPS IN RELATION TO EDUCATIONAL APPARATUS AND EQUIPMENT AND THEIR USE; EDUCATIONAL RE-

SEARCH, ASSESSMENT AND EVALUATION OF TEACHING, TRAINING, LEARNING AND EDUCATIONAL METHODS, STRATEGIES AND APPARATUS; CONSULTANCY SERVICES RELATING TO TEACHING METHODS AND EDUCATION AND LEARNING STRATEGIES; PROVISION OF INFORMATION IN RELATION TO ALL THE AFORESAID SERVICES AND PROVISION OF ADVICE IN RELATION TO ALL THE AFORESAID SERVICES, NAMELY, EDUCATIONAL RESEARCH, PROVISION OF ADVICE IN RELATION TO TRAINING, TEACHING, LEARNING AND EDUCATION; PROVISION OF ADVICE IN RELATION TO TRAINING, TEACHING, LEARNING AND EDUCATION METHODS, STRATEGIES AND APPARATUS; PROVISION OF NON-DOWNLOADABLE ON-LINE ELECTRONIC PUBLICATIONS, NAMELY, MAGAZINES IN THE FIELD OF EDUCATION AND MANUALS, TEXT BOOKS, ARTICLES, NEWSLETTERS, LESSON GUIDES IN THE FIELD OF EDUCATION INCLUDING LEARNING AND KNOWLEDGE TRANSFER STRATEGIES; CONSULTANCY SERVICES IN THE FIELD OF EDUCATION AND TEACHING (U.S. CLS. 100, 101 AND 107).

**CLASS 42—SCIENTIFIC AND COMPUTER SERVICES**

FOR TECHNOLOGICAL RESEARCH SERVICES IN THE FIELD OF EDUCATION; COMPUTER ADVISORY AND CONSULTANCY SERVICES; COMPUTER SOFTWARE DEVELOPMENT SERVICES; COMPUTER PROGRAMMING SERVICES; GRAPHIC DESIGN; INDUSTRIAL AND INTERIOR DESIGN SERVICES; DESIGN AND DEVELOPMENT OF COMPUTER HARDWARE AND SOFTWARE; RENTAL AND HIRE OF COMPUTERS; RENTAL OF BLANK MAGNETIC DATA CARRIERS; RENTAL AND HIRE OF COMPUTER SOFTWARE; PROGRAMMING OF EDUCATIONAL SOFTWARE; CONSULTANCY SERVICES IN THE FIELD OF MULTI-MEDIA COMPUTER-RELATED TECHNOLOGY (U.S. CLS. 100 AND 101).

CHERYL CLAYTON, EXAMINING ATTORNEY

SN 85-109,825. BACKFLOW PREVENTION SPECIALISTS, INC., SUNNYVALE, CA. FILED 8-17-2010.



NO CLAIM IS MADE TO THE EXCLUSIVE RIGHT TO USE "INC.", APART FROM THE MARK AS SHOWN.

THE MARK CONSISTS OF A STYLIZED IMAGE OF A BACKFLOW PREVENTION DEVICE, NAMELY, A REDUCED PRESSURE PRINCIPLE BACKFLOW PREVENTION ASSEMBLY, WITH THE WORDS "BACKFLOW PREVENTION" ABOVE AND THE WORDS "SPECIALISTS INC." BELOW THE ASSEMBLY DESIGN ALL IN AN OVAL.

SEC. 2(F) AS TO "BACKFLOW PREVENTION SPECIALISTS INC."

**CLASS 35—ADVERTISING AND BUSINESS**

FOR RETAIL STORE SERVICES AND ONLINE RETAIL STORE SERVICES IN THE FIELD OF BACKFLOW PREVENTION DEVICES, NAMELY, DOUBLE-CHECK BACKFLOW PREVENTION ASSEMBLIES, REDUCED PRESSURE PRINCIPLE BACKFLOW PREVENTION ASSEMBLIES, PRESSURE VACUUM BREAKER ASSEMBLIES, AND SPILL RESISTANT PRESSURE VACUUM BREAKER BACKFLOW PREVENTION ASSEMBLIES, REPLACEMENT PARTS THEREFOR, AND REPAIR KITS THEREFOR COMPRISING SPARE PARTS, TOOLS AND INSTRUCTIONS (U.S. CLS. 100, 101 AND 102).

FIRST USE 9-1-1988; IN COMMERCE 11-18-1991.

**CLASS 37—CONSTRUCTION AND REPAIR**

FOR INSTALLATION, REPAIR, AND MAINTENANCE OF COMMERCIAL, RESIDENTIAL, BUSINESS, AND PUBLIC UTILITY WATER LINE BACKFLOW PREVENTION DEVICES, NAMELY, DOUBLE-CHECK BACKFLOW PREVENTION ASSEMBLIES, REDUCED PRESSURE PRINCIPLE BACKFLOW PREVENTION ASSEMBLIES, PRESSURE VACUUM BREAKER ASSEMBLIES, AND SPILL RESISTANT PRESSURE VACUUM BREAKER BACKFLOW PREVENTION ASSEMBLIES (U.S. CLS. 100, 103 AND 106).

FIRST USE 9-1-1988; IN COMMERCE 11-18-1988.

**CLASS 42—SCIENTIFIC AND COMPUTER SERVICES**

FOR TESTING, ANALYSIS AND EVALUATION FOR OTHERS FOR THE PURPOSE OF CERTIFICATION OF BACKFLOW PREVENTION DEVICES, NAMELY, DOUBLE-CHECK BACKFLOW PREVENTION ASSEMBLIES, REDUCED PRESSURE PRINCIPLE BACKFLOW PREVENTION ASSEMBLIES, PRESSURE VACUUM BREAKER ASSEMBLIES, AND SPILL RESISTANT PRESSURE VACUUM BREAKER BACKFLOW PREVENTION ASSEMBLIES; INSPECTION OF COMMERCIAL, RESIDENTIAL, BUSINESS, AND PUBLIC UTILITY WATER LINE BACKFLOW PREVENTION DEVICES, NAMELY, DOUBLE-CHECK BACKFLOW PREVENTION ASSEMBLIES, REDUCED PRESSURE PRINCIPLE BACKFLOW PREVENTION ASSEMBLIES, PRESSURE VACUUM BREAKER ASSEMBLIES, AND SPILL RESISTANT PRESSURE VACUUM BREAKER BACKFLOW PREVENTION ASSEMBLIES (U.S. CLS. 100 AND 101).

FIRST USE 9-1-1988; IN COMMERCE 11-18-1991. DAVID C. REIHNER, EXAMINING ATTORNEY

SN 85-109,883. GENKI MEDIA LLC, WASHINGTON, DC. FILED 8-17-2010.

**Genki Media LLC**

THE MARK CONSISTS OF STANDARD CHARACTERS WITHOUT CLAIM TO ANY PARTICULAR FONT, STYLE, SIZE, OR COLOR.

NO CLAIM IS MADE TO THE EXCLUSIVE RIGHT TO USE "MEDIA LLC", APART FROM THE MARK AS SHOWN.

THE ENGLISH TRANSLATION OF "GENKI" IN THE MARK IS "HAPPY AND HEALTHY".

**CLASS 35—ADVERTISING AND BUSINESS**

FOR BUSINESS CONSULTATION IN THE FIELD OF MEDIA; BUSINESS DEVELOPMENT CONSULTING SERVICES (U.S. CLS. 100, 101 AND 102).

FIRST USE 3-2-2010; IN COMMERCE 8-1-2010.

**CLASS 41—EDUCATION AND ENTERTAINMENT**

FOR ARRANGING, ORGANIZING, CONDUCTING, AND HOSTING SOCIAL ENTERTAINMENT EVENTS (U.S. CLS. 100, 101 AND 107).

FIRST USE 3-2-2010; IN COMMERCE 6-1-2010.  
ROBERT C. CLARK JR., EXAMINING ATTORNEY

SN 85-112,659. MW LABS INC., SAVANNAH, GA. FILED 8-20-2010.

**INK RELIEF**

THE MARK CONSISTS OF STANDARD CHARACTERS WITHOUT CLAIM TO ANY PARTICULAR FONT, STYLE, SIZE, OR COLOR.

NO CLAIM IS MADE TO THE EXCLUSIVE RIGHT TO USE "INK", APART FROM THE MARK AS SHOWN.

**CLASS 3—COSMETICS AND CLEANING PREPARATIONS**

FOR NON-MEDICATED SKIN CARE PRODUCTS, NAMELY, CLEANSERS, LOTIONS, CREAMS AND GELS FOR USE BEFORE, DURING AND AFTER GETTING TATTOOS (U.S. CLS. 1, 4, 6, 50, 51 AND 52).

**CLASS 5—PHARMACEUTICALS**

FOR MEDICATED SKIN CARE PRODUCTS, NAMELY, CLEANSERS, LOTIONS, CREAMS AND GELS FOR USE BEFORE, DURING AND AFTER GETTING TATTOOS (U.S. CLS. 6, 18, 44, 46, 51 AND 52).

NAAKWAMA ANKRAH, EXAMINING ATTORNEY

SN 85-113,545. ALLIANCE FOR WOMEN IN MEDIA, INC., MCLEAN, VA. FILED 8-23-2010.



OWNER OF U.S. REG. NO. 3,862,240.

NO CLAIM IS MADE TO THE EXCLUSIVE RIGHT TO USE "ALLIANCE FOR WOMEN IN MEDIA", APART FROM THE MARK AS SHOWN.

THE COLOR(S) RED, GRAY AND WHITE IS/ARE CLAIMED AS A FEATURE OF THE MARK.

THE MARK CONSISTS OF THE WHITE LETTERS "M" AND "W" WITHIN A DARK RED ROUNDED SQUARE ON THE LEFT SIDE OF THE MARK. THE LETTERS "M" AND "W" ARE PLACED AS MIRROR IMAGES SO AS TO FORM THE SYMBOL FOR FAST FORWARD. THE LETTER "M" IS SLANTED TO THE LEFT ON THE TOP HALF OF THE DARK RED ROUNDED SQUARE. THE LETTER "W" IS SLANTED TO THE RIGHT ON THE BOTTOM HALF OF THE DARK RED ROUNDED SQUARE TO EMPHASIZE THAT THE "W" IS A REFLECTION OF THE "M". THE WORDS "ALLIANCE FOR" APPEAR IN GRAY CAPITAL LETTERS TO THE RIGHT OF THE ROUNDED DARK RED SQUARE. THE WORD "ALLIANCE" IS WRITTEN IN

SLIGHTLY LARGER LETTERS THAN THE WORD "FOR". THE LETTER "A" IN "ALLIANCE" IS SLIGHTLY LARGER THAN THE REMAINING LETTERS OF THE WORD. IN SLIGHTLY LARGER LETTERS BELOW THE WORDS "ALLIANCE FOR" ARE THE WORDS "WOMEN IN MEDIA" IN RED CAPITAL LETTERS. THE FIRST LETTERS OF EACH WORD, "W", "I," AND "M", ARE ALL SLIGHTLY LARGER THAN THE REST OF THE RESPECTIVE WORDS. THE RED SQUARE AND THE RED WORDINGS HAVE WHITE ACCENTS.

**CLASS 35—ADVERTISING AND BUSINESS**

FOR ASSOCIATION SERVICES, NAMELY, PROMOTING THE INTERESTS OF WOMEN IN THE MEDIA (U.S. CLS. 100, 101 AND 102).

FIRST USE 8-10-2010; IN COMMERCE 8-10-2010.

**CLASS 41—EDUCATION AND ENTERTAINMENT**

FOR EDUCATIONAL SERVICES, NAMELY, ARRANGING AND PROVIDING SEMINARS, FORUMS, WORKSHOPS, CONFERENCES, EDUCATIONAL MEETINGS AND WEBINARS IN THE FIELDS OF MEDIA, PROFESSIONAL AND LEADERSHIP DEVELOPMENT AND THE ADVANCEMENT OF WOMEN IN THE MEDIA (U.S. CLS. 100, 101 AND 107).

FIRST USE 8-10-2010; IN COMMERCE 8-10-2010.

ALEX KEAM, EXAMINING ATTORNEY

SN 85-113,556. CERTAINTTEED CORPORATION, VALLEY FORGE, PA. FILED 8-23-2010.

**GO RETROFITTING**

THE MARK CONSISTS OF STANDARD CHARACTERS WITHOUT CLAIM TO ANY PARTICULAR FONT, STYLE, SIZE, OR COLOR.

NO CLAIM IS MADE TO THE EXCLUSIVE RIGHT TO USE "RETROFITTING", APART FROM THE MARK AS SHOWN.

**CLASS 7—MACHINERY**

FOR GLASS FIBER INSULATION BLOWING MACHINE (U.S. CLS. 13, 19, 21, 23, 31, 34 AND 35).

**CLASS 17—RUBBER GOODS**

FOR FIBERGLASS, FOAM AND LOOSE FILL INSULATION FOR USE IN BUILDINGS AND CONSTRUCTION (U.S. CLS. 1, 5, 12, 13, 35 AND 50).

**CLASS 37—CONSTRUCTION AND REPAIR**

FOR INSTALLATION OF INSULATION IN BUILDINGS (U.S. CLS. 100, 103 AND 106).

CAROL SPILS, EXAMINING ATTORNEY

SN 85-114,881. AFA INDUSTRIES, ROMEO, MI. FILED 8-24-2010.

SN 85-115,677. SYNGENTA PARTICIPATIONS AG, BASEL, SWITZERLAND, FILED 8-25-2010.

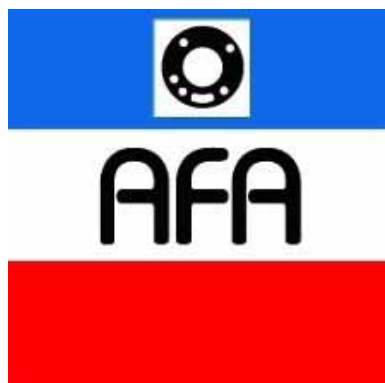

THE COLOR(S) BLUE, WHITE, RED AND BLACK IS/ARE CLAIMED AS A FEATURE OF THE MARK.

THE MARK CONSISTS OF THREE STACKED RECTANGLES. THE TOP RECTANGLE IS BLUE WITH A ROUND PERFORATED GASKET IN BLACK WITH A WHITE SQUARE AROUND IT. THE SECOND RECTANGLE IS WHITE AND HAS THE LETTERS "AFA" IN BLACK. THE THIRD RECTANGLE IS RED.

#### CLASS 7—MACHINERY

FOR HEAVY DUTY DIESEL ENGINE VEHICLE PARTS, NAMELY, CYLINDER LINERS, PISTONS, PISTON RINGS, BEARINGS, BALL BEARINGS, BUSHINGS BEING PART OF MACHINES, CAMSHAFTS FOR MACHINES, CRANKSHAFTS, CYLINDER BLOCKS BEING PARTS OF MACHINES, CYLINDER HEADS FOR ENGINES, CYLINDER BEING PARTS OF MACHINES, MOTORS AND ENGINES, WATER PUMPS, OIL PUMPS, NON-ELECTRIC SLEEVES FOR USE IN LINING PISTON CYLINDERS IN INTERNAL COMBUSTION ENGINES, VALVES, VALVE GUIDES, OIL COOLER, AND AFTER COOLERS; HEAVY-DUTY DIESEL ENGINE PARTS, NAMELY, NON-METAL GASKETS, NON-METAL O-RINGS AND NON-METAL SEALS (U.S. CLS. 13, 19, 21, 23, 31, 34 AND 35).

FIRST USE 4-1-1986, THE MARK WAS FIRST USED ANYWHERE IN A DIFFERENT FORM OTHER THAN THAT SOUGHT TO BE REGISTERED AT LEAST AS EARLY AS 04/01/1986; IN COMMERCE 4-1-1986, THE MARK WAS FIRST USED IN COMMERCE IN A DIFFERENT FORM OTHER THAN THAT SOUGHT TO BE REGISTERED AT LEAST AS EARLY AS 04/01/1986..

#### CLASS 9—ELECTRICAL AND SCIENTIFIC APPARATUS

FOR HEAVY-DUTY DIESEL ENGINE VEHICLE PARTS, NAMELY, THERMOSTATS (U.S. CLS. 21, 23, 26, 36 AND 38).

FIRST USE 4-1-1986, THE MARK WAS FIRST USED ANYWHERE IN A DIFFERENT FORM OTHER THAN THAT SOUGHT TO BE REGISTERED AT LEAST AS EARLY AS 04/01/1986; IN COMMERCE 4-1-1986, THE MARK WAS FIRST USED IN COMMERCE IN A DIFFERENT FORM OTHER THAN THAT SOUGHT TO BE REGISTERED AT LEAST AS EARLY AS 04/01/1986.

#### CLASS 12—VEHICLES

FOR VEHICLES AND STRUCTURAL PARTS AND FITTINGS THEREFOR (U.S. CLS. 19, 21, 23, 31, 35 AND 44).

FIRST USE 4-1-1986, THE MARK WAS FIRST USED ANYWHERE IN A DIFFERENT FORM OTHER THAN THAT SOUGHT TO BE REGISTERED AT LEAST AS EARLY AS 04/01/1986; IN COMMERCE 4-1-1986, THE MARK WAS FIRST USED IN COMMERCE IN A DIFFERENT FORM OTHER THAN THAT SOUGHT TO BE REGISTERED AT LEAST AS EARLY AS 04/01/1986..

SHAUNIA CARLYLE, EXAMINING ATTORNEY

# Zeffex

THE MARK CONSISTS OF STANDARD CHARACTERS WITHOUT CLAIM TO ANY PARTICULAR FONT, STYLE, SIZE, OR COLOR.

THE WORDING "ZEFFEX" HAS NO MEANING IN A FOREIGN LANGUAGE.

#### CLASS 1—CHEMICALS

FOR CHEMICALS USED IN AGRICULTURE, HORTICULTURE AND FORESTRY EXCEPT FUNGICIDES, HERBICIDES, INSECTICIDES AND PARASITICIDES; CHEMICAL PREPARATIONS FOR THE TREATMENT OF SEEDS (U.S. CLS. 1, 5, 6, 10, 26 AND 46).

#### CLASS 5—PHARMACEUTICALS

FOR PREPARATIONS FOR DESTROYING VERMIN; FUNGICIDES (U.S. CLS. 6, 18, 44, 46, 51 AND 52).

WARREN L. OLANDRIA, EXAMINING ATTORNEY

SN 85-116,215. BENARDETT K. JNO-FINN, NEW ORLEANS, LA. FILED 8-26-2010.



THE MARK CONSISTS OF A SYLIZED LETTER "S" WITH A DESIGN OF A LEAF COMPRISING THE LOWER PORTION OF THE LETTER POSITIONED ABOVE THE STYLIZED WORD "SENICA".

THE WORDING "SENICA" HAS NO MEANING IN A FOREIGN LANGUAGE.

**CLASS 3—COSMETICS AND CLEANING PREPARATIONS**

FOR BATH, BODY, HAIR AND HOME CARE PRODUCTS, NAMELY, SHEA BODY BUTTERS, BODY BUTTERS, BODY AND BATH OILS, LIQUID SOAPS, SCENTED ROOM SPRAYS, BATH AND BODY SOAPS IN LIQUID AND SOLID FORM, BAR SOAPS, MASSAGE OILS, NON-MEDICATED BODY SALVES AND BALMS, NON-MEDICATED BATH SALTS, BODY SCRUBS, BODY JELLIES, BODY SHOWER GELS, BODY LOTIONS, BODY CREAMS, NON-MEDICATED LIP BALM, COSMETICS IN THE NATURE OF HERBAL FACIAL STEAM PREPARATIONS, FACIAL CLEANSERS, FACIAL TONERS AND SPLASHES, NON-MEDICATED FACIAL SERUMS, HAIR SHAMPOOS, HAIR RINSES, HAIR CONDITIONERS, HAIR POMADES, HAIR OILS; HAIR LOTIONS, PERFUMES, FRAGRANCES, BATH HERBS IN THE NATURE OF TEAS, ESSENTIAL OILS, ESSENTIAL OILS FOR PERSONAL USE, SOY CANDLES, CANDLES, NON-MEDICATED BATH FIZZY SALTS IN SOLID FORM COMPOSED OF EFFERVESCENT MATERIALS, BATH MILKS, FLORAL COLOGNE WATER, NON-MEDICATED HAND AND FOOT CARE PREPARATIONS, NAMELY, MOISTURIZERS, SOAKS, SCRUBS; BODY SPRAY, NON-MEDICATED HERBAL EXTRACTS SOLD AS COMPONENTS OF COSMETICS, NON-MEDICATED BODY POWDER, NON-MEDICATED BATH SALTS, PRODUCT MAKING MAKE-UP KITS COMPRISED OF COSMETICS, GIFT BASKETS CONTAINING COSMETIC PREPARATIONS (U.S. CLS. 1, 4, 6, 50, 51 AND 52).

**CLASS 41—EDUCATION AND ENTERTAINMENT**

FOR TEACHING IN THE FIELD OF NATURAL PRODUCT MAKING SUCH AS MASSAGE CANDLES, BODY OILS, CANDLES, SHAMPOOS; TEACHING IN THE FIELD OF BENEFITS OF NATURAL PRODUCT INGREDIENTS, NAMELY, HERBS, OILS, BUTTERS, WAXES (U.S. CLS. 100, 101 AND 107).

MICHAEL LITZAU, EXAMINING ATTORNEY

SN 85-116,778. BOB EVANS FARMS, INC., COLUMBUS, OH. FILED 8-26-2010.

FOR BREAKFAST. FOR DINNER.  
FOR GENERATIONS.

THE MARK CONSISTS OF STANDARD CHARACTERS WITHOUT CLAIM TO ANY PARTICULAR FONT, STYLE, SIZE, OR COLOR.

**CLASS 29—MEATS AND PROCESSED FOODS**

FOR SAUSAGE; BRATWURST; KIELBASA; BACON; CANADIAN BACON; HAM; PORK RIBS; CHILI; SOUPS; PREPARED ENTREES AND SIDE DISHES CONSISTING PRIMARILY OF MEAT, POULTRY, SAUSAGE, EGGS, PROCESSED POTATOES, PROCESSED SWEET POTATOES, FRUIT, OR VEGETABLES (U.S. CL. 46).

**CLASS 30—STAPLE FOODS**

FOR SANDWICHES; BURRITOS; BISCUITS; BISCUITS FILLED WITH FRUIT, VEGETABLES, EGGS, MEAT, GRAVY, OR CHEESE; PREPARED ENTREES AND SIDE DISHES CONSISTING PRIMARILY OF PASTA, BREAD, BISCUITS, OATMEAL, GRAVY, OR STUFFING CONTAINING BREAD; KOLACHES, NAMELY, DOUGH-BASED POCKETS WITH FILLING CONSISTING PRIMARILY OF MEAT, POULTRY, VEGETABLES OR CHEESE; SAUSAGE WRAPPED IN DOUGH; BREADS AND CAKES; GRAVY; SALAD DRESSING; OATMEAL; BISCUITS AND GRAVY; BARBECUE SAUCE; COFFEE; POT PIES (U.S. CL. 46).

SHARON MEIER, EXAMINING ATTORNEY

SN 85-116,262. FERENCIK, ED, RENO, NV. FILED 8-26-2010.

BUTCHER'S KITCHEN

THE MARK CONSISTS OF STANDARD CHARACTERS WITHOUT CLAIM TO ANY PARTICULAR FONT, STYLE, SIZE, OR COLOR.

NO CLAIM IS MADE TO THE EXCLUSIVE RIGHT TO USE "KITCHEN", APART FROM THE MARK AS SHOWN.

**CLASS 8—HAND TOOLS**

FOR MEAT TENDERIZER, NAMELY, A KITCHEN MALLET; MEAT TENDERIZER, NAMELY, A PRONGED INSTRUMENT FOR POUNDING MEAT (U.S. CLS. 23, 28 AND 44).

FIRST USE 12-28-2008; IN COMMERCE 3-25-2009.

**CLASS 41—EDUCATION AND ENTERTAINMENT**

FOR EDUCATIONAL AND ENTERTAINMENT SERVICES, NAMELY, A CONTINUING PROGRAM ABOUT FOOD PREPARATION AND COOKING ACCESSIBLE BY RADIO, TELEVISION, SATELLITE, AUDIO, VIDEO AND COMPUTER NETWORKS (U.S. CLS. 100, 101 AND 107).

FIRST USE 2-18-2010; IN COMMERCE 2-18-2010.  
INGA ERVIN, EXAMINING ATTORNEY

SN 85-116,959. 3 SISTERS SUSTAINABLE INVESTMENTS, LLC, PHILADELPHIA, PA. FILED 8-26-2010.

WikiPositive

THE MARK CONSISTS OF STANDARD CHARACTERS WITHOUT CLAIM TO ANY PARTICULAR FONT, STYLE, SIZE, OR COLOR.

**CLASS 41—EDUCATION AND ENTERTAINMENT**

FOR ELECTRONIC PUBLISHING SERVICES, NAMELY, PUBLICATION OF TEXT AND GRAPHIC WORKS OF OTHERS ON THE INTERNET IN THE FIELD OF ENVIRONMENTAL RESEARCH, SOCIAL RESEARCH AND SOCIAL INVESTMENT RESEARCH; EDUCATIONAL SERVICES, NAMELY, TELESEMINARS AND WEBINARS CONCERNING THE ADMINISTRATION OF AN ENCYCLOPEDIA PROJECT AND THE USE AND ADMINISTRATION OF ENCYCLOPEDIA ARTICLE ENTRIES; EDUCATIONAL SERVICES, NAMELY, TELESEMINARS AND WEBINARS IN THE FIELD OF ENVIRONMENTAL RESEARCH, SOCIAL RESEARCH AND SOCIAL INVESTMENT RESEARCH (U.S. CLS. 100, 101 AND 107).

FIRST USE 6-9-2010; IN COMMERCE 6-9-2010.

**CLASS 42—SCIENTIFIC AND COMPUTER SERVICES**

FOR PROVIDING INFORMATION, NEWS AND COMMENTARY IN THE FIELD OF ENVIRONMENTAL RESEARCH, SOCIAL RESEARCH AND SOCIAL INVESTMENT RESEARCH; PROVIDING A WEBSITE FEATURING INFORMATION AND LINKS RELATING TO OTHER ON-LINE RESOURCES FOR ENVIRONMENTAL RESEARCH, SOCIAL RESEARCH AND SOCIAL INVESTMENT RESEARCH (U.S. CLS. 100 AND 101).

FIRST USE 6-9-2010; IN COMMERCE 6-9-2010.

PAUL E. FAHRENKOPF, EXAMINING ATTORNEY

**CLASS 41—EDUCATION AND ENTERTAINMENT**

FOR BUSINESS EDUCATION AND TRAINING SERVICES, NAMELY, DEVELOPING, AND FACILITATING CUSTOMIZED IN-COMPANY LEADERSHIP AND EXECUTIVE DEVELOPMENT PROGRAMS, PROVIDING EXECUTIVE COACHING SERVICES, AND PROVIDING PUBLIC AND IN-COMPANY KEYNOTE PRESENTATIONS TO BUSINESS LEADERS; CONDUCTING WORKSHOPS AND SEMINARS IN BUSINESS MANAGEMENT, LEADERSHIP, INTERPERSONAL COMMUNICATION, BUSINESS DEVELOPMENT AND EMPLOYEE MOTIVATION; ENTERTAINMENT IN THE NATURE OF LIVE STAGE PERFORMANCES IN THE NATURE OF SEMINARS AND ROLE-PLAYING WORKSHOPS OR LECTURE FOR HIRE IN THE FIELD OF BUSINESS MANAGEMENT, LEADERSHIP, INTERPERSONAL COMMUNICATION, BUSINESS DEVELOPMENT AND EMPLOYEE MOTIVATION BY AN INDIVIDUAL; ENTERTAINMENT SERVICES, NAMELY, PROVIDING VIDEO PODCASTS IN THE FIELD OF BUSINESS MANAGEMENT, LEADERSHIP, INTERPERSONAL COMMUNICATION, BUSINESS DEVELOPMENT AND EMPLOYEE MOTIVATION; PROFESSIONAL COACHING SERVICES IN THE FIELD OF BUSINESS MANAGEMENT, LEADERSHIP, INTERPERSONAL COMMUNICATION, BUSINESS DEVELOPMENT AND EMPLOYEE MOTIVATION; PROVIDING GROUP COACHING IN THE FIELD OF BUSINESS MANAGEMENT, LEADERSHIP, INTERPERSONAL COMMUNICATION, BUSINESS DEVELOPMENT AND EMPLOYEE MOTIVATION (U.S. CLS. 100, 101 AND 107).

JEFFREY LOOK, EXAMINING ATTORNEY

SN 85-117,327. SHARI HARLEY, LLC, DENVER, CO. FILED 8-27-2010.



SN 85-118,065. MOTION THEORY, INC., VENICE, CA. FILED 8-28-2010.

THE NAME(S), PORTRAIT(S), AND/OR SIGNATURE(S) SHOWN IN THE MARK IDENTIFIES "SHARI HARLEY", WHOSE CONSENT(S) TO REGISTER IS MADE OF RECORD.

THE COLOR(S) BROWN AND MAGENTA IS/ARE CLAIMED AS A FEATURE OF THE MARK.

THE MARK CONSISTS OF A SPEECH BALLOON POINT TO THE RIGHT. THE BALLOON IS BISECTED BY A PUZZLE PIECE DESIGN. THE LEFT HALF OF THE PUZZLE PIECE IS BROWN AND THE RIGHT IS MAGENTA. TO THE RIGHT OF THE SPEECH BALLOON IS THE WORDS "SHARI HARLEY" IN BROWN LETTERING. THE WORD "SHARI" APPEARS ABOVE THE WORD "HARLEY".

**CLASS 16—PAPER GOODS AND PRINTED MATTER**

FOR BOOKMARKS; CALENDARS; EDUCATIONAL PUBLICATIONS, NAMELY, HAND-OUTS, EDUCATIONAL LEARNING CARDS, FLASH CARDS, ACTIVITY CARDS, WORKBOOKS, TEXTBOOKS, ACTIVITY BOOKS, PUZZLE BOOKS, PRINTED PUZZLES, TEACHER GUIDES, MANUALS, AND EDUCATIONAL BOOKLET IN THE FIELDS OF BUSINESS MANAGEMENT, LEADERSHIP, INTERPERSONAL COMMUNICATION, BUSINESS DEVELOPMENT AND EMPLOYEE MOTIVATION; GREETINGS CARDS AND POSTCARDS; NOTE PADS; PENS (U.S. CLS. 2, 5, 22, 23, 29, 37, 38 AND 50).

**DeadVolt**

THE MARK CONSISTS OF STANDARD CHARACTERS WITHOUT CLAIM TO ANY PARTICULAR FONT, STYLE, SIZE, OR COLOR.

**CLASS 9—ELECTRICAL AND SCIENTIFIC APPARATUS**

FOR PRE-RECORDED CDS, VIDEO TAPES, LASER DISKS AND DVDS FEATURING MUSIC AND MUSICAL PERFORMANCES; DIGITAL MUSIC DOWNLOADABLE FROM THE INTERNET; VIDEO RECORDINGS FEATURING MUSIC AND MUSIC PERFORMANCES; DOWNLOADABLE RING TONES AND GRAPHICS FOR MOBILE PHONES; PROTECTIVE CARRYING CASES FOR PORTABLE MUSIC PLAYERS, NAMELY, MP3 PLAYERS (U.S. CLS. 21, 23, 26, 36 AND 38).

**CLASS 25—CLOTHING**

FOR CLOTHING, NAMELY, HATS AND T-SHIRTS (U.S. CLS. 22 AND 39).



**CLASS 35—ADVERTISING AND BUSINESS**

FOR PREPARING ADVERTISEMENTS FOR OTHERS, NAMELY, PREPARING VIDEO ADVERTISING AND PROMOTIONAL VIDEOS FOR COMMERCIAL USE PRESENTED TO MOBILE COMMUNICATIONS DEVICES VIA A GLOBAL COMPUTER NETWORK AND WIRELESS NETWORKS; PRODUCING PROMOTIONAL AUDIO VISUAL RECORDINGS PRESENTED TO MOBILE COMMUNICATIONS DEVICES VIA A GLOBAL COMPUTER NETWORK AND WIRELESS NETWORKS; PRODUCING VIDEO INFOMERCIALS PRESENTED TO MOBILE COMMUNICATIONS DEVICES VIA A GLOBAL COMPUTER NETWORK AND WIRELESS NETWORKS; PRODUCTION OF VIDEO ADVERTISING MATTER AND VIDEO COMMERCIALS PRESENTED TO MOBILE COMMUNICATIONS DEVICES VIA A GLOBAL COMPUTER NETWORK AND WIRELESS NETWORKS (U.S. CLS. 100, 101 AND 102).

**CLASS 41—EDUCATION AND ENTERTAINMENT**

FOR ENTERTAINMENT SERVICES, NAMELY, PROVIDING A WEB SITE FEATURING NON-DOWNLOADABLE MUSICAL PERFORMANCES, MUSICAL VIDEOS, RELATED FILM CLIPS, PHOTOGRAPHS, AND OTHER MULTIMEDIA MATERIALS FEATURING MUSIC AND MUSICAL PERFORMANCES; ENTERTAINMENT SERVICES, NAMELY, NON-DOWNLOADABLE RINGTONES, PRE-RECORDED MUSIC, MUSIC VIDEOS AND GRAPHICS PRESENTED TO MOBILE COMMUNICATIONS DEVICES VIA A GLOBAL COMPUTER NETWORK AND WIRELESS NETWORKS; ENTERTAINMENT, NAMELY, LIVE MUSIC CONCERTS; PROVIDING AN INTERNET WEBSITE PORTAL IN THE FIELD OF MUSIC; PROVIDING AN INTERNET WEBSITE PORTAL FEATURING LINKS TO MUSICAL ARTIST WEBSITES AND MUSIC PERFORMANCE TICKET INFORMATION; PROVISION OF INFORMATION RELATING TO MUSIC; ON-LINE JOURNALS, NAMELY, BLOGS FEATURING MUSIC-RELATED CONTENT (U.S. CLS. 100, 101 AND 107).

ROBIN MITTLER, EXAMINING ATTORNEY

SN 85-118,555. ATO PICTURES, LLC, CHARLOTTESVILLE, VA. FILED 8-30-2010.



THE MARK CONSISTS OF THE STACKED WORDS "ART TAKES OVER", WITH INITIAL LETTERS "ATO" APPEARING IN LIGHT SHADING ON A DARKER SHADED BACKGROUND.

**CLASS 9—ELECTRICAL AND SCIENTIFIC APPARATUS**

FOR MOTION PICTURES AND MOTION PICTURE FILMS FEATURING DRAMA, ACTION ADVENTURE, COMEDY, DOCUMENTARY, AND HISTORICAL SUBJECT MATTER; PRE-RECORDED DVDS, DVD-ROMS, AND VIDEOTAPES FEATURING DRAMA, ACTION ADVENTURE, COMEDY, DOCUMENTARY, AND HISTORICAL SUBJECT MATTER; DOWNLOADABLE FILMS AND MOVIES FEATURING DRAMA, ACTION ADVENTURE, COMEDY, DOCUMENTARY, AND HISTORICAL SUBJECT MATTER PROVIDED VIA A VIDEO-ON-DEMAND SERVICE (U.S. CLS. 21, 23, 26, 36 AND 38). FIRST USE 8-20-2010; IN COMMERCE 8-20-2010.

**CLASS 41—EDUCATION AND ENTERTAINMENT**

FOR PROVISION OF NON-DOWNLOADABLE FILMS AND MOVIES VIA A VIDEO-ON-DEMAND SERVICE; PRODUCTION AND DISTRIBUTION OF MOTION PICTURE FILMS; MOTION PICTURE SONG PRODUCTION; MOVIE STUDIOS; ORGANIZING EXHIBITIONS FOR MOTION PICTURE FILMS (U.S. CLS. 100, 101 AND 107). FIRST USE 7-2-2010; IN COMMERCE 7-2-2010. HEATHER BIDDULPH, EXAMINING ATTORNEY

SN 85-119,275. KUGE CONSULTORIA EMPRESARIAL LTDA -ME, SAO JOSE DOS CAMPOS SP, BRAZIL, FILED 8-30-2010.



THE MARK CONSISTS OF A STYLIZED LETTER "U" APPEARING ABOVE THE TERM "URGH".

**CLASS 25—CLOTHING**

FOR ATHLETIC APPAREL, NAMELY, SHIRTS, PANTS, JACKETS, FOOTWEAR, HATS AND CAPS, ATHLETIC UNIFORMS; BELTS; HOODED SWEAT SHIRTS; JEANS; SHORT-SLEEVED OR LONG-SLEEVED T-SHIRTS; SHORTS; SWEAT PANTS; SWEAT SHIRTS (U.S. CLS. 22 AND 39). FIRST USE 1-1-1982; IN COMMERCE 1-1-1982.

**CLASS 28—TOYS AND SPORTING GOODS**

FOR BALL BEARINGS FOR SKATEBOARDS; NUTS AND BOLTS FOR SKATEBOARDS; SKATEBOARD DECKS; SKATEBOARD GRIP TAPES; SKATEBOARD TRUCKS; SKATEBOARD WHEELS; SKATEBOARDS (U.S. CLS. 22, 23, 38 AND 50). FIRST USE 1-1-1982; IN COMMERCE 1-1-1982.

RON FAIRBANKS, EXAMINING ATTORNEY

SN 85-119,473. EAU D'ITALIE S.R.L., ROME, ITALY, FILED 8-31-2010.

## VERDE ARETUSA

THE MARK CONSISTS OF STANDARD CHARACTERS WITHOUT CLAIM TO ANY PARTICULAR FONT, STYLE, SIZE, OR COLOR.

PRIORITY CLAIMED UNDER SEC. 44(D) ON ERP CMNTY TM OFC APPLICATION NO. 009340738, FILED 8-30-2010, REG. NO. 009340738, DATED 1-17-2011, EXPIRES 8-30-2020.

THE ENGLISH TRANSLATION OF "VERDE" IN THE MARK IS GREEN. THE WORDING "ARETUSA" HAS NO MEANING IN A FOREIGN LANGUAGE.

### CLASS 3—COSMETICS AND CLEANING PREPARATIONS

FOR PERFUMES (U.S. CLS. 1, 4, 6, 50, 51 AND 52).

### CLASS 4—LUBRICANTS AND FUELS

FOR CANDLES (U.S. CLS. 1, 6 AND 15).  
TIMOTHY FINNEGAN, EXAMINING ATTORNEY

SN 85-119,536. GRODY, STEPHEN D., NEWTON, MA. FILED 8-31-2010.

## Known Presence

THE MARK CONSISTS OF STANDARD CHARACTERS WITHOUT CLAIM TO ANY PARTICULAR FONT, STYLE, SIZE, OR COLOR.

OWNER OF U.S. REG. NO. 3,876,712.

### CLASS 9—ELECTRICAL AND SCIENTIFIC APPARATUS

FOR BROADBAND WIRELESS EQUIPMENT, NAMELY, TELECOMMUNICATIONS BASE STATION EQUIPMENT FOR CELLULAR AND FIXED NETWORKING AND COMMUNICATIONS APPLICATIONS (U.S. CLS. 21, 23, 26, 36 AND 38).

FIRST USE 8-31-2010; IN COMMERCE 8-31-2010.

### CLASS 38—COMMUNICATION

FOR COMMUNICATION SERVICES, NAMELY, TRANSMISSION OF VOICE, AUDIO, VISUAL IMAGES AND DATA BY TELECOMMUNICATIONS NETWORKS, WIRELESS COMMUNICATION NETWORKS, THE INTERNET, INFORMATION SERVICES NETWORKS AND DATA NETWORKS (U.S. CLS. 100, 101 AND 104).

FIRST USE 1-1-2010; IN COMMERCE 1-1-2010.

### CLASS 42—SCIENTIFIC AND COMPUTER SERVICES

FOR PROVIDING CUSTOMER-DEFINED GENERATED CONTENT AND CONTENT OF OTHERS AUTOMATICALLY SELECTED AND CUSTOMIZED BASED ON THE KNOWN OR ESTIMATED GEOGRAPHICAL LOCATION OF AN INTERNET, MOBILE TELEPHONE OR OTHER WIRED OR WIRELESS DIGITAL NETWORK BASED CUSTOMER (U.S. CLS. 100 AND 101).

FIRST USE 1-1-2010; IN COMMERCE 1-1-2010.

TOBY BULLOFF, EXAMINING ATTORNEY

SN 85-119,993. HELLBOUND GLORY, LLC, RENO, NV. FILED 8-31-2010.

## Hellbound Glory

THE MARK CONSISTS OF STANDARD CHARACTERS WITHOUT CLAIM TO ANY PARTICULAR FONT, STYLE, SIZE, OR COLOR.

### CLASS 9—ELECTRICAL AND SCIENTIFIC APPARATUS

FOR PRERECORDED CDS FEATURING MUSIC; PRERECORDED AND DOWNLOADABLE VIDEOS FEATURING MUSICAL PERFORMANCES AND MUSICAL RECORDINGS; DOWNLOADABLE GRAPHICS, MUSIC, PLAYLISTS, IMAGES IN THE FIELD OF MUSIC AND ENTERTAINMENT AND VIDEOS VIA A GLOBAL COMPUTER NETWORK AND WIRELESS DEVICES (U.S. CLS. 21, 23, 26, 36 AND 38).

FIRST USE 6-1-2006; IN COMMERCE 6-1-2006.

### CLASS 25—CLOTHING

FOR CLOTHING; NAMELY, SHIRTS, T-SHIRTS, SWEATSHIRTS, HATS, AND UNDERWEAR (U.S. CLS. 22 AND 39).

FIRST USE 8-1-2007; IN COMMERCE 8-1-2007.

### CLASS 41—EDUCATION AND ENTERTAINMENT

FOR ENTERTAINMENT SERVICES IN THE NATURE OF LIVE MUSICAL PERFORMANCES; PROVIDING A WEBSITE FEATURING NON-DOWNLOADABLE MUSICAL PERFORMANCES AND NON-DOWNLOADABLE VIDEOS OF SAME, RELATED NON-DOWNLOADABLE VIDEO CLIPS AND OTHER RELATED NON-DOWNLOADABLE MUSICAL MULTI-MEDIA MATERIALS (U.S. CLS. 100, 101 AND 107).

FIRST USE 6-1-2004; IN COMMERCE 6-1-2004.

DOMINIC J. FERRAIUOLO, EXAMINING ATTORNEY

SN 85-121,005. STERLING PUBLISHING CO., INC., NEW YORK, NY. FILED 9-1-2010.



NO CLAIM IS MADE TO THE EXCLUSIVE RIGHT TO USE "PRESS", APART FROM THE MARK AS SHOWN. THE MARK CONSISTS OF THE TERMS "RANKIN STREET PRESS" ATOP THE SILHOUETTE OF AN OPEN BOOK.

**CLASS 9—ELECTRICAL AND SCIENTIFIC APPARATUS**

FOR ELECTRONIC DOWNLOADABLE PUBLICATIONS IN THE NATURE OF BOOKS FEATURING CRAFTS (U.S. CLS. 21, 23, 26, 36 AND 38).

**CLASS 16—PAPER GOODS AND PRINTED MATTER**

FOR SERIES OF PRINTED BOOKS FEATURING CRAFTS; PRINTED CRAFT INSTRUCTIONAL BOOKS (U.S. CLS. 2, 5, 22, 23, 29, 37, 38 AND 50). DAVID C. REIHNER, EXAMINING ATTORNEY

**CLASS 9—ELECTRICAL AND SCIENTIFIC APPARATUS**

FOR COMPONENTS AND TEST MEASUREMENT EQUIPMENT FOR HIGH SPEED ELECTRONICS IN THE NATURE OF ACTIVE COMPONENTS, NAMELY, LINEAR AMPLIFIERS, DRIVER AMPLIFIERS, COMB GENERATORS, AND PACKED SAMPLER CIRCUITRY AND ACTIVE MODULES COMPRISED OF DRIVER AMPLIFIER AND BIAS CONTROLLER MODULES; PASSIVE COMPONENTS, NAMELY, BIAS TEES, LOW PASS FILTERS, POWER DIVIDERS, PICK-OFF TEES, ATTENUATORS, DC BLOCKS, IMPULSE FORMING NETWORKS, BALUNS AND TRANSFORMERS; SIGNAL GENERATION MODULES AND INSTRUMENTS, NAMELY, HIGH-SPEED PULSE GENERATORS, GENERAL PURPOSE PROGRAMMABLE PULSE GENERATORS, TDR/TDT MODULES; AND SIGNAL MEASUREMENT MODULES AND INSTRUMENTS, NAMELY, EQUIVALENT TIME SAMPLER MODULES, REAL TIME SAMPLER MODULES, GENERAL PURPOSE SAMPLER MODULES (U.S. CLS. 21, 23, 26, 36 AND 38).

FIRST USE 1-1-1992; IN COMMERCE 1-1-1992.

**CLASS 40—MATERIAL TREATMENT**

FOR CUSTOM MANUFACTURE OF COMPONENTS, MODULES AND TEST MEASUREMENT EQUIPMENT FOR HIGH SPEED ELECTRONICS (U.S. CLS. 100, 103 AND 106).

FIRST USE 1-1-1992; IN COMMERCE 1-1-1992. KELLEY WELLS, EXAMINING ATTORNEY

SN 85-124,452. TBC TRADEMARKS, LLC, LAS VEGAS, NV. FILED 9-7-2010.



OWNER OF U.S. REG. NO. 3,394,010. NO CLAIM IS MADE TO THE EXCLUSIVE RIGHT TO USE "TIRES", "SERVICE", "BRAKES", "BATTERIES", APART FROM THE MARK AS SHOWN. THE MARK CONSISTS OF A STYLIZED TIRE IN A CIRCLE DESIGN, TO THE RIGHT OF WHICH ARE THE LETTERS "NTB", AND BELOW WHICH ARE THE WORDS TIRES, SERVICE, BRAKES, BATTERIES, SEPARATED BY MIDDLE DOTS.

**CLASS 35—ADVERTISING AND BUSINESS**

FOR RETAIL STORE SERVICES IN THE FIELD OF TIRES AND VEHICLE PARTS AND ACCESSORIES (U.S. CLS. 100, 101 AND 102). FIRST USE 6-0-1997; IN COMMERCE 6-0-1997.

**CLASS 37—CONSTRUCTION AND REPAIR**

FOR VEHICLE MAINTENANCE AND REPAIR SERVICES; TIRE REPAIR SERVICES; TIRE ROTATION AND BALANCING (U.S. CLS. 100, 103 AND 106). FIRST USE 6-0-1997; IN COMMERCE 6-0-1997. B. PARADEWELAI, EXAMINING ATTORNEY

SN 85-123,695. PICOSECOND PULSE LABS, INC., BOULDER, CO. FILED 9-7-2010.



OWNER OF U.S. REG. NO. 2,842,278. NO CLAIM IS MADE TO THE EXCLUSIVE RIGHT TO USE "PULSE LABS", APART FROM THE MARK AS SHOWN. THE MARK CONSISTS OF AN ELECTROCARDIOGRAPHIC PATTERN WITH THE WORD "PICOSECOND" ABOVE THE PATTERN LINE, AND FIVE OBLONG DOTS AND THE WORDS "PULSE LABS" DISPLAYED HORIZONTALLY BELOW THE PATTERN LINE.

SN 85-124,471. TBC TRADEMARKS, LLC, LAS VEGAS, NV.  
FILED 9-7-2010.

**NTB**

THE MARK CONSISTS OF STANDARD CHARACTERS WITHOUT CLAIM TO ANY PARTICULAR FONT, STYLE, SIZE, OR COLOR.

OWNER OF U.S. REG. NO. 3,394,010.

#### **CLASS 35—ADVERTISING AND BUSINESS**

FOR RETAIL STORE SERVICES IN THE FIELD OF TIRES AND VEHICLE PARTS AND ACCESSORIES (U.S. CLS. 100, 101 AND 102).

FIRST USE 6-0-1997; IN COMMERCE 6-0-1997.

#### **CLASS 37—CONSTRUCTION AND REPAIR**

FOR VEHICLE MAINTENANCE AND REPAIR SERVICES; TIRE REPAIR SERVICES; TIRE ROTATION AND BALANCING (U.S. CLS. 100, 103 AND 106).

FIRST USE 6-0-1997; IN COMMERCE 6-0-1997.

B. PARADEWELAI, EXAMINING ATTORNEY

SN 85-124,909. ACTELIS NETWORKS INC., FREMONT, CA.  
FILED 9-8-2010.



OWNER OF U.S. REG. NO. 2,643,401.

NO CLAIM IS MADE TO THE EXCLUSIVE RIGHT TO USE "NETWORKS", APART FROM THE MARK AS SHOWN.

THE COLOR(S) BLUE AND BLACK IS/ARE CLAIMED AS A FEATURE OF THE MARK.

THE MARK CONSISTS OF THE WORDS "ACTELIS NETWORKS", ALL IN BLACK, WITH A BLUE ORBIT DESIGN THROUGH THE TERM "ACTELIS".

#### **CLASS 9—ELECTRICAL AND SCIENTIFIC APPARATUS**

FOR COMPUTER HARDWARE FOR TELECOMMUNICATIONS AND DATA COMMUNICATIONS APPLICATIONS; EMBEDDED COMPUTER SOFTWARE FOR PROVIDING COMMUNICATIONS LINKS AND PROTOCOLS, FOR OPTIMIZING TRANSMISSION PERFORMANCE, FOR MANAGING SYSTEM CONFIGURATION AND SYSTEM COMPONENTS AND FOR MONITORING SYSTEM PERFORMANCE; COMPUTER AND TELECOMMUNICATIONS HARDWARE, NAMELY, ETHERNET AGGREGATION SWITCHES, REPEATERS AND ACCESS APPARATUS, AND INSTRUCTIONAL MANUALS, SOLD AS A UNIT (U.S. CLS. 21, 23, 26, 36 AND 38).

FIRST USE 12-31-1998; IN COMMERCE 12-31-1998.

#### **CLASS 42—SCIENTIFIC AND COMPUTER SERVICES**

FOR COMPUTER TECHNOLOGY CONSULTING SERVICES, NAMELY, CONSULTING SERVICES IN THE FIELDS OF DESIGN, SELECTION, IMPLEMENTATION AND USE OF COMPUTER HARDWARE, COMPUTER SOFTWARE, COMPUTER NETWORKING AND ETHERNET TECHNOLOGY FOR OTHERS (U.S. CLS. 100 AND 101).

FIRST USE 12-31-1998; IN COMMERCE 12-31-1998.

SANJEEV VOHRA, EXAMINING ATTORNEY

SN 85-124,940. SCORPION SPORTS, INC., LAKE FOREST, CA. FILED 9-8-2010.



THE MARK CONSISTS OF A STYLIZED LETTER "S".

#### **CLASS 9—ELECTRICAL AND SCIENTIFIC APPARATUS**

FOR SAFETY PRODUCTS, NAMELY, SAFETY HELMETS, SPORTS HELMETS, MOTORCYCLE HELMETS; SPORTS PROTECTIVE GEAR FOR MOTORCYCLING, NAMELY, PROTECTIVE PADS, ARM GUARDS, ELBOW GUARDS, WRIST GUARDS, KNEE GUARDS, SHIN GUARDS, LEG GUARDS, FOREARM GUARDS (U.S. CLS. 21, 23, 26, 36 AND 38).

#### **CLASS 25—CLOTHING**

FOR CLOTHING, NAMELY, LEATHER JACKETS, JACKETS, LEATHER PANTS, PANTS, SHIRTS, T-SHIRTS, GYM SHORTS AND SHIRTS, JOGGING SUITS, VESTS, JEANS, BELTS AND ACCESSORIES, NAMELY, HATS, SCARVES, GLOVES AND MITTENS (U.S. CLS. 22 AND 39).

JOHN E. MICHOS, EXAMINING ATTORNEY

SN 85-125,128. ADLOV, INC., LONG BEACH, CA. FILED 9-8-2010.

**ADLOV**

THE MARK CONSISTS OF STANDARD CHARACTERS WITHOUT CLAIM TO ANY PARTICULAR FONT, STYLE, SIZE, OR COLOR.

**CLASS 9—ELECTRICAL AND SCIENTIFIC APPARATUS**

FOR SOFTWARE THAT ENABLES DISPLAYING, TAGGING AND IDENTIFICATION OF GOODS AND SERVICES IN VIDEO CONTENT FOR ADVERTISING AND PROMOTIONAL PURPOSES; APPLICATION PROGRAMMING INTERFACE THAT ENABLE WEB DEVELOPERS TO INTEGRATE VIDEO CONTENT AND FUNCTIONALITY INTO WEBSITES, SOFTWARE APPLICATIONS, AND DEVICES (U.S. CLS. 21, 23, 26, 36 AND 38).

**CLASS 35—ADVERTISING AND BUSINESS**

FOR ADVERTISING AND PROMOTIONAL SERVICES ON BEHALF OF OTHERS (U.S. CLS. 100, 101 AND 102).  
KIM SAITO, EXAMINING ATTORNEY



SN 85-125,627. PHOENIX LAWN & GARDEN, INC., FRANKFORT, IN. FILED 9-9-2010.

WE MAKE TALL GRASS SHORT

THE MARK CONSISTS OF STANDARD CHARACTERS WITHOUT CLAIM TO ANY PARTICULAR FONT, STYLE, SIZE, OR COLOR.

**CLASS 35—ADVERTISING AND BUSINESS**

FOR RETAIL STORE SERVICES FEATURING LAWN CARE EQUIPMENT, NAMELY, LAWN MOWERS, STRING TRIMMERS AND LAWN EDGERS (U.S. CLS. 100, 101 AND 102).  
FIRST USE 7-1-2006; IN COMMERCE 10-12-2006.

**CLASS 37—CONSTRUCTION AND REPAIR**

FOR REPAIR SERVICES FEATURING LAWN CARE EQUIPMENT, NAMELY, LAWN MOWERS, STRING TRIMMERS AND LAWN EDGERS (U.S. CLS. 100, 103 AND 106).  
FIRST USE 7-1-2006; IN COMMERCE 10-12-2006.  
REGINA DRUMMOND, EXAMINING ATTORNEY



SN 85-125,686. FORSIGHT VISION3, INC., MENLO PARK, CA. FILED 9-9-2010.

SECURE LENS

THE MARK CONSISTS OF STANDARD CHARACTERS WITHOUT CLAIM TO ANY PARTICULAR FONT, STYLE, SIZE, OR COLOR.  
NO CLAIM IS MADE TO THE EXCLUSIVE RIGHT TO USE "LENS", APART FROM THE MARK AS SHOWN.

**CLASS 10—MEDICAL APPARATUS**

FOR MEDICAL DEVICES, NAMELY, CORNEAL SHIELDS AND CONTACT LENSES FOR OPHTHALMOLOGICAL USE RELATED TO VISION CORRECTION (U.S. CLS. 26, 39 AND 44).

**CLASS 41—EDUCATION AND ENTERTAINMENT**

FOR TRAINING AND TEACHING IN THE FIELD OF OPHTHALMOLOGY (U.S. CLS. 100, 101 AND 107).

**CLASS 44—MEDICAL, BEAUTY AND AGRICULTURAL SERVICES**

FOR TREATMENT OF EYE DISEASES AND CONDITIONS; OPHTHALMOLOGICAL SURGICAL SERVICES (U.S. CLS. 100 AND 101).  
ANNE MADDEN, EXAMINING ATTORNEY



SN 85-126,669. DAIMLER PARTS BRAND GMBH, 70567 STUTTGART, FED REP GERMANY, FILED 9-10-2010.

4US

THE MARK CONSISTS OF STANDARD CHARACTERS WITHOUT CLAIM TO ANY PARTICULAR FONT, STYLE, SIZE, OR COLOR.

**CLASS 12—VEHICLES**

FOR AUTOMOBILES AND THEIR STRUCTURAL PARTS (U.S. CLS. 19, 21, 23, 31, 35 AND 44).

**CLASS 37—CONSTRUCTION AND REPAIR**

FOR REPAIR AND MAINTENANCE OF MOTOR VEHICLES (U.S. CLS. 100, 103 AND 106).  
COLLEEN DOMBROW, EXAMINING ATTORNEY



SN 85-126,681. FAIRLEIGH DICKINSON UNIVERSITY, TEANECK, NJ. FILED 9-10-2010.

ACADEMIC STAR ALLIANCE

THE MARK CONSISTS OF STANDARD CHARACTERS WITHOUT CLAIM TO ANY PARTICULAR FONT, STYLE, SIZE, OR COLOR.

NO CLAIM IS MADE TO THE EXCLUSIVE RIGHT TO USE "ACADEMIC" AND "ALLIANCE", APART FROM THE MARK AS SHOWN.

**CLASS 35—ADVERTISING AND BUSINESS**

FOR EDUCATIONAL SERVICES, NAMELY, PROVIDING A CONSORTIUM OF EDUCATION INSTITUTIONS AT THE COLLEGE AND UNIVERSITY LEVEL FOR ARRANGING AND ADMINISTERING STUDENT RECRUITMENT INITIATIVES, FACULTY RECRUITMENT, AND STUDY ABROAD PROGRAMS (U.S. CLS. 100, 101 AND 102).

**CLASS 41—EDUCATION AND ENTERTAINMENT**

FOR EDUCATIONAL SERVICES, NAMELY, PROVIDING A CONSORTIUM OF EDUCATION INSTITUTIONS AT THE COLLEGE AND UNIVERSITY LEVEL FOR ARRANGING AND ADMINISTERING ACADEMIC AND GLOBAL STUDY COURSES AND SEMINARS AND THE SHORT-TERM EXCHANGE OF SELECT FACULTY MEMBERS AND STUDENTS AMONG CONSORTIUM MEMBERS (U.S. CLS. 100, 101 AND 107).

KATHLEEN LORENZO, EXAMINING ATTORNEY

SN 85-126,964. CHECKSMART FINANCIAL COMPANY, DUBLIN, OH. FILED 9-10-2010.



**EXPRES\$S**  
**CONSUMER LOANS**

NO CLAIM IS MADE TO THE EXCLUSIVE RIGHT TO USE "CONSUMER LOANS" (AS TO CLASS 36 ONLY), APART FROM THE MARK AS SHOWN.

THE MARK CONSISTS OF THE WORD "EXPRESS" WITH AN ARROW EXTENDING FROM THE CENTER OF THE LETTER "E" AND THE LETTERS "SS" IN THE FORM OF DOLLAR SIGNS, AND THE WORDS "CONSUMER LOANS" DIRECTLY BELOW.

**CLASS 35—ADVERTISING AND BUSINESS**

FOR RETAIL STORE SERVICES FEATURING STORED VALUE CARDS, TELEPHONE CALLING CARDS AND POSTAGE STAMPS (U.S. CLS. 100, 101 AND 102).

FIRST USE 12-10-2008; IN COMMERCE 12-10-2008.

**CLASS 36—INSURANCE AND FINANCIAL**

FOR AUTOMATED TELLER MACHINE SERVICES; BILL PAYMENT SERVICES; CHECK CASHING; ELECTRONIC FUNDS TRANSFER; ISSUING STORED VALUE CARDS; LOAN FINANCING; MONEY ORDER SERVICES; MONEY WIRING SERVICES; TELEPHONE CALLING CARD SERVICES (U.S. CLS. 100, 101 AND 102).

FIRST USE 12-10-2008; IN COMMERCE 12-10-2008.

GINA FINK, EXAMINING ATTORNEY

SN 85-126,971. CHECKSMART FINANCIAL COMPANY, DUBLIN, OH. FILED 9-10-2010.



**Southwest**  
**CHECK CASHING**

NO CLAIM IS MADE TO THE EXCLUSIVE RIGHT TO USE "CHECK CASHING" (AS TO CLASS 36 ONLY), APART FROM THE MARK AS SHOWN.

THE MARK CONSISTS OF THE WORD "SOUTHWEST" WITH THE "T" IN THE FORM OF A CACTUS AND A CIRCLE AT THE TOP AND TO THE LEFT OF THE "T" DEPICTING THE SUN, AND THE WORDS "CHECK CASHING" DIRECTLY BELOW.

**CLASS 35—ADVERTISING AND BUSINESS**

FOR RETAIL STORE SERVICES FEATURING STORED VALUE CARDS, TELEPHONE CALLING CARDS AND POSTAGE STAMPS (U.S. CLS. 100, 101 AND 102).

FIRST USE 9-2-2002; IN COMMERCE 9-2-2002.

**CLASS 36—INSURANCE AND FINANCIAL**

FOR AUTOMATED TELLER MACHINE SERVICES; BILL PAYMENT SERVICES; CHECK CASHING; ELECTRONIC FUNDS TRANSFER; ISSUING STORED VALUE CARDS; LOAN FINANCING; MONEY ORDER SERVICES; MONEY WIRING SERVICES; TELEPHONE CALLING CARD SERVICES (U.S. CLS. 100, 101 AND 102).

FIRST USE 9-2-2002; IN COMMERCE 9-2-2002.

GINA FINK, EXAMINING ATTORNEY

SN 85-127,571. CORECENTRIC SOLUTIONS, INC., FORMERLY CG INDUSTRIES, LTD., GLENDALE HEIGHTS, IL. FILED 9-11-2010.



**CoreCentric**  
**Solutions**

NO CLAIM IS MADE TO THE EXCLUSIVE RIGHT TO USE "SOLUTIONS", APART FROM THE MARK AS SHOWN.

THE MARK CONSISTS OF A LOGO PORTION COMPRISING TWO REVERSELY DIRECTED SEMICIRCULAR ARROWS, ONE ABOVE THE OTHER, EACH ARROW HAVING A WIDE BODY PORTION THAT IS TURNED OVER, REPRESENTING A THREE DIMENSIONAL CIRCULAR REGENERATION MOTIF, EACH ARROW FRONT CONVERGING ARROWHEAD POINTING TO THE OPPOSED END OF THE OTHER ARROW, WITH THE LITERAL ELEMENT "CORECENTRIC" ON A SEPARATE LINE FROM "SOLUTIONS".

**CLASS 9—ELECTRICAL AND SCIENTIFIC APPARATUS**

FOR REMANUFACTURED ELECTRONIC PARTS AND COMPONENTS FOR USE IN RESIDENTIAL AND COMMERCIAL APPLIANCES; ELECTRONIC CONTROLS FOR USE AS REPLACEMENT PARTS IN HOUSEHOLD APPLIANCES AND COMMERCIAL EQUIPMENT; REPLACEMENT PARTS FOR MAJOR HOUSEHOLD APPLIANCES, WASHERS, DRYERS, OVENS, GARAGE DOOR OPENERS, WATER SOFTENERS, THERMOSTATS, LIGHTING, HVAC, BATTERY CHARGERS AND TELECOM, COMMERCIAL AND HOME FITNESS EQUIPMENT, NAMELY, SWITCHES, SYSTEM BOARDS AND PROCESSORS, THERMOSTATS, TIMERS, JOYSTICKS AND INVERTERS (U.S. CLS. 21, 23, 26, 36 AND 38).

FIRST USE 8-2-2010; IN COMMERCE 8-2-2010.

**CLASS 37—CONSTRUCTION AND REPAIR**

FOR REMANUFACTURE OF ELECTRONIC PARTS AND COMPONENTS TO THE ORDER AND/OR SPECIFICATION OF OTHERS; MAINTENANCE, REPAIR, REPLACEMENT AND REMANUFACTURE OF ELECTRONIC PARTS AND COMPONENTS FOR RESIDENTIAL AND COMMERCIAL APPLIANCES (U.S. CLS. 100, 103 AND 106).

FIRST USE 8-2-2010; IN COMMERCE 8-2-2010.

JILL PRATER, EXAMINING ATTORNEY

SN 85-127,672. BROWN, KEVIN, SANTA MARIA, CA. FILED 9-12-2010.



THE NAME(S), PORTRAIT(S), AND/OR SIGNATURE(S) SHOWN IN THE MARK DOES NOT IDENTIFY A PARTICULAR LIVING INDIVIDUAL.

THE MARK CONSISTS OF A SMILING MAN WITH A FULL HEAD OF HAIR WEARING A WORK UNIFORM THAT HAS A SHORT-SLEEVED SHIRT WITH A POCKET AND CREASED PANTS, A BELT WITH A BUCKLE, SHOES AND A BOW TIE HOLDING A SANDER IN HIS HANDS.

#### CLASS 25—CLOTHING

FOR APRONS; CAPS; CAPS WITH VISORS; COATS; COVERALLS; COVERUPS; DUNGAREES; HATS; HOODED PULLOVERS; JACKETS; LEATHER COATS; LEATHER HEADWEAR; LEATHER JACKETS; OVERALLS; PONCHOS; PULLOVERS; SHIRTS; SMOCKS; SWEAT PANTS; SWEAT SHIRTS; T-SHIRTS; TANK TOPS; UNIFORMS; VISORS (U.S. CLS. 22 AND 39).

#### CLASS 35—ADVERTISING AND BUSINESS

FOR ADVERTISEMENT FOR OTHERS ON THE INTERNET; CONCESSION STANDS FEATURING PRODUCTS PERTAINING TO CARE AND MAINTENANCE OF AUTOMOBILES, TRUCKS, MOTORCYCLES AND OTHER TRANSPORTATION VEHICLES, TOOLS AND OTHER PRODUCTS FOR MAINTENANCE OF AUTOMOBILES, TRUCKS, MOTORCYCLES AND OTHER TRANSPORTATION VEHICLES, ACCESSORIES AND PARTS FOR AUTOMOBILES, TRUCKS, MOTORCYCLES AND OTHER TRANSPORTATION VEHICLES, MEMORABILIA PERTAINING TO AUTOMOBILES, TRUCKS, MOTORCYCLES AND OTHER TRANSPORTATION VEHICLES, PRODUCTS DESIGNED FOR USE WITH AUTOMOBILES, TRUCK, MOTORCYCLES AND OTHER TRANSPORTATION VEHICLES, FINISHING, CUTTING, AND POLISHING FOR MAINTAINING SURFACES OF AUTOMOBILES, TRUCK, MOTORCYCLES AND OTHER TRANSPORTATION VEHICLES, SANDING DISCS, SHEETS, AND BLOCKS FOR MAINTAINING SURFACES OF AUTOMOBILES, TRUCK, MOTORCYCLES AND OTHER TRANSPORTATION VEHICLES, GRINDING DISCS MAINTAINING SURFACES OF AUTOMOBILES, TRUCK, MOTORCYCLES AND OTHER TRANSPORTATION VEHICLES, BACKING PLATES AND INTERFACE DISCS FOR USE WITH SANDING MACHINES FOR MAINTAINING SURFACES OF AUTOMOBILES, TRUCK, MOTORCYCLES AND OTHER TRANSPORTATION VEHICLES, SANDERS, POLISHERS, SPONGES, DETAILING CLAY, SQUEEGEES, DETAILING CLOTHS, DOME HAND BLOCKS, DENIBBING FILE, AND SANDING PADS FOR MAINTAINING SURFACES OF AUTOMOBILES, TRUCK, MOTORCYCLES AND OTHER TRANSPORTATION VEHICLES, AND CLEANSING AND POLISHING PREPARATIONS FOR CLEANING AND MAINTAINING SURFACES OF AUTOMOBILES, TRUCK, MOTORCYCLES AND OTHER TRANSPORTATION VEHICLES; ON-LINE ADVERTISING SERVICES FOR OTHERS; ON-LINE RETAIL GIFT SHOPS; ON-LINE RETAIL STORE SERVICES FEATURING A WIDE VARIETY OF CONSUMER GOODS OF OTHERS; ON-LINE RETAIL STORE SERVICES FEATURING PRODUCTS PERTAINING TO CARE AND

MAINTENANCE OF AUTOMOBILES, TRUCKS, MOTORCYCLES AND OTHER TRANSPORTATION VEHICLES, TOOLS AND OTHER PRODUCTS FOR MAINTENANCE OF AUTOMOBILES, TRUCKS, MOTORCYCLES AND OTHER TRANSPORTATION VEHICLES, ACCESSORIES AND PARTS FOR AUTOMOBILES, TRUCKS, MOTORCYCLES AND OTHER TRANSPORTATION VEHICLES, MEMORABILIA PERTAINING TO AUTOMOBILES, TRUCKS, MOTORCYCLES AND OTHER TRANSPORTATION VEHICLES, PRODUCTS DESIGNED FOR USE WITH AUTOMOBILES, TRUCK, MOTORCYCLES AND OTHER TRANSPORTATION VEHICLES, FINISHING, CUTTING, AND POLISHING FOR MAINTAINING SURFACES OF AUTOMOBILES, TRUCK, MOTORCYCLES AND OTHER TRANSPORTATION VEHICLES, SANDING DISCS, SHEETS, AND BLOCKS FOR MAINTAINING SURFACES OF AUTOMOBILES, TRUCK, MOTORCYCLES AND OTHER TRANSPORTATION VEHICLES, GRINDING DISCS MAINTAINING SURFACES OF AUTOMOBILES, TRUCK, MOTORCYCLES AND OTHER TRANSPORTATION VEHICLES, BACKING PLATES AND INTERFACE DISCS FOR USE WITH SANDING MACHINES FOR MAINTAINING SURFACES OF AUTOMOBILES, TRUCK, MOTORCYCLES AND OTHER TRANSPORTATION VEHICLES, SANDERS, POLISHERS, SPONGES, DETAILING CLAY, SQUEEGEES, DETAILING CLOTHS, DOME HAND BLOCKS, DENIBBING FILE, AND SANDING PADS FOR MAINTAINING SURFACES OF AUTOMOBILES, TRUCK, MOTORCYCLES AND OTHER TRANSPORTATION VEHICLES, AND CLEANSING AND POLISHING PREPARATIONS FOR CLEANING AND MAINTAINING SURFACES OF AUTOMOBILES, TRUCK, MOTORCYCLES AND OTHER TRANSPORTATION VEHICLES; ON-LINE WHOLESALE AND RETAIL STORE SERVICES FEATURING PRODUCTS, PERTAINING TO CARE AND MAINTENANCE OF AUTOMOBILES, TRUCKS, MOTORCYCLES AND OTHER TRANSPORTATION VEHICLES, TOOLS AND OTHER PRODUCTS FOR MAINTENANCE OF AUTOMOBILES, TRUCKS, MOTORCYCLES AND OTHER TRANSPORTATION VEHICLES, ACCESSORIES AND PARTS FOR AUTOMOBILES, TRUCKS, MOTORCYCLES AND OTHER TRANSPORTATION VEHICLES, MEMORABILIA PERTAINING TO AUTOMOBILES, TRUCKS, MOTORCYCLES AND OTHER TRANSPORTATION VEHICLES, PRODUCTS DESIGNED FOR USE WITH AUTOMOBILES, TRUCK, MOTORCYCLES AND OTHER TRANSPORTATION VEHICLES, FINISHING, CUTTING, AND POLISHING FOR MAINTAINING SURFACES OF AUTOMOBILES, TRUCK, MOTORCYCLES AND OTHER TRANSPORTATION VEHICLES, SANDING DISCS, SHEETS, AND BLOCKS FOR MAINTAINING SURFACES OF AUTOMOBILES, TRUCK, MOTORCYCLES AND OTHER TRANSPORTATION VEHICLES, GRINDING DISCS MAINTAINING SURFACES OF AUTOMOBILES, TRUCK, MOTORCYCLES AND OTHER TRANSPORTATION VEHICLES, BACKING PLATES AND INTERFACE DISCS FOR USE WITH SANDING MACHINES FOR MAINTAINING SURFACES OF AUTOMOBILES, TRUCK, MOTORCYCLES AND OTHER TRANSPORTATION VEHICLES, SANDERS, POLISHERS, SPONGES, DETAILING CLAY, SQUEEGEES, DETAILING CLOTHS, DOME HAND BLOCKS, DENIBBING FILE, AND SANDING PADS FOR MAINTAINING SURFACES OF AUTOMOBILES, TRUCK, MOTORCYCLES AND OTHER TRANSPORTATION VEHICLES, AND CLEANSING AND POLISHING PREPARATIONS FOR CLEANING AND MAINTAINING SURFACES OF AUTOMOBILES, TRUCK, MOTORCYCLES AND OTHER TRANSPORTATION VEHICLES; ONLINE RETAIL SERVICES THROUGH DIRECT SOLICITATION BY SALESPERSONS DIRECTED TO END-USERS FEATURING PRODUCTS PERTAINING TO CARE AND MAINTENANCE OF AUTOMOBILES, TRUCKS, MOTORCYCLES AND OTHER TRANSPORTATION VEHICLES, TOOLS AND OTHER PRODUCTS FOR MAINTENANCE OF AUTOMOBILES, TRUCKS, MOTORCYCLES AND OTHER TRANSPORTATION VEHICLES, ACCESSORIES AND PARTS FOR AUTOMOBILES, TRUCKS, MOTORCYCLES AND OTHER TRANSPORTATION VEHICLES, MEMORABILIA PERTAINING TO AUTOMOBILES, TRUCKS, MOTORCYCLES AND OTHER TRANSPORTATION VEHICLES, PRODUCTS DESIGNED FOR USE WITH AUTOMOBILES, TRUCK, MOTORCYCLES AND OTHER TRANSPORTATION VEHICLES, FINISHING, CUTTING, AND POLISHING FOR MAINTAINING SURFACES OF AUTOMOBILES, TRUCK, MOTORCYCLES AND OTHER TRANSPORTATION VEHICLES, SANDING

DISCS, SHEETS, AND BLOCKS FOR MAINTAINING SURFACES OF AUTOMOBILES, TRUCK, MOTORCYCLES AND OTHER TRANSPORTATION VEHICLES, GRINDING DISCS MAINTAINING SURFACES OF AUTOMOBILES, TRUCK, MOTORCYCLES AND OTHER TRANSPORTATION VEHICLES, BACKING PLATES AND INTERFACE DISCS FOR USE WITH SANDING MACHINES FOR MAINTAINING SURFACES OF AUTOMOBILES, TRUCK, MOTORCYCLES AND OTHER TRANSPORTATION VEHICLES, SANDERS, POLISHERS, SPONGES, DETAILING CLAY, SQUEEGEES, DETAILING CLOTHS, DOME HAND BLOCKS, DENIBBING FILE, AND SANDING PADS FOR MAINTAINING SURFACES OF AUTOMOBILES, TRUCK, MOTORCYCLES AND OTHER TRANSPORTATION VEHICLES, AND CLEANSING AND POLISHING PREPARATIONS FOR CLEANING AND MAINTAINING SURFACES OF AUTOMOBILES, TRUCK, MOTORCYCLES AND OTHER TRANSPORTATION VEHICLES; ONLINE SERVICE FOR CONNECTING SOCIAL NETWORK USERS WITH RETAILERS FOR THE PURPOSE OF FACILITATING DISCOUNTED PURCHASES; OPERATING AN ON-LINE SHOPPING SITE IN THE FIELD OF PRODUCTS PERTAINING TO CARE AND MAINTENANCE OF AUTOMOBILES, TRUCKS, MOTORCYCLES AND OTHER TRANSPORTATION VEHICLES, TOOLS AND OTHER PRODUCTS FOR MAINTENANCE OF AUTOMOBILES, TRUCKS, MOTORCYCLES AND OTHER TRANSPORTATION VEHICLES, ACCESSORIES AND PARTS FOR AUTOMOBILES, TRUCKS, MOTORCYCLES AND OTHER TRANSPORTATION VEHICLES, MEMORABILIA PERTAINING TO AUTOMOBILES, TRUCKS, MOTORCYCLES AND OTHER TRANSPORTATION VEHICLES, PRODUCTS DESIGNED FOR USE WITH AUTOMOBILES, TRUCK, MOTORCYCLES AND OTHER TRANSPORTATION VEHICLES, FINISHING, CUTTING, AND POLISHING FOR MAINTAINING SURFACES OF AUTOMOBILES, TRUCK, MOTORCYCLES AND OTHER TRANSPORTATION VEHICLES, SANDING DISCS, SHEETS, AND BLOCKS FOR MAINTAINING SURFACES OF AUTOMOBILES, TRUCK, MOTORCYCLES AND OTHER TRANSPORTATION VEHICLES, GRINDING DISCS MAINTAINING SURFACES OF AUTOMOBILES, TRUCK, MOTORCYCLES AND OTHER TRANSPORTATION VEHICLES, BACKING PLATES AND INTERFACE DISCS FOR USE WITH SANDING MACHINES FOR MAINTAINING SURFACES OF AUTOMOBILES, TRUCK, MOTORCYCLES AND OTHER TRANSPORTATION VEHICLES, SANDERS, POLISHERS, SPONGES, DETAILING CLAY, SQUEEGEES, DETAILING CLOTHS, DOME HAND BLOCKS, DENIBBING FILE, AND SANDING PADS FOR MAINTAINING SURFACES OF AUTOMOBILES, TRUCK, MOTORCYCLES AND OTHER TRANSPORTATION VEHICLES, AND CLEANSING AND POLISHING PREPARATIONS FOR CLEANING AND MAINTAINING SURFACES OF AUTOMOBILES, TRUCK, MOTORCYCLES AND OTHER TRANSPORTATION VEHICLES; OPERATING ON-LINE MARKETPLACES FEATURING PRODUCTS PERTAINING TO CARE AND MAINTENANCE OF AUTOMOBILES, TRUCKS, MOTORCYCLES AND OTHER TRANSPORTATION VEHICLES, TOOLS AND OTHER PRODUCTS FOR MAINTENANCE OF AUTOMOBILES, TRUCKS, MOTORCYCLES AND OTHER TRANSPORTATION VEHICLES, ACCESSORIES AND PARTS FOR AUTOMOBILES, TRUCKS, MOTORCYCLES AND OTHER TRANSPORTATION VEHICLES, MEMORABILIA PERTAINING TO AUTOMOBILES, TRUCKS, MOTORCYCLES AND OTHER TRANSPORTATION VEHICLES, PRODUCTS DESIGNED FOR USE WITH AUTOMOBILES, TRUCK, MOTORCYCLES AND OTHER TRANSPORTATION VEHICLES, FINISHING, CUTTING, AND POLISHING FOR MAINTAINING SURFACES OF AUTOMOBILES, TRUCK, MOTORCYCLES AND OTHER TRANSPORTATION VEHICLES, SANDING DISCS, SHEETS, AND BLOCKS FOR MAINTAINING SURFACES OF AUTOMOBILES, TRUCK, MOTORCYCLES AND OTHER TRANSPORTATION VEHICLES, GRINDING DISCS MAINTAINING SURFACES OF AUTOMOBILES, TRUCK, MOTORCYCLES AND OTHER TRANSPORTATION VEHICLES, BACKING PLATES AND INTERFACE DISCS FOR USE WITH SANDING MACHINES FOR MAINTAINING SURFACES OF AUTOMOBILES, TRUCK, MOTORCYCLES AND OTHER TRANSPORTATION VEHICLES, SANDERS, POLISHERS, SPONGES, DETAILING CLAY, SQUEEGEES, DETAILING CLOTHS, DOME HAND BLOCKS, DENIBBING FILE, AND SANDING PADS FOR MAINTAINING SURFACES OF AUTOMOBILES, TRUCK, MOTORCYCLES

AND OTHER TRANSPORTATION VEHICLES, AND CLEANSING AND POLISHING PREPARATIONS FOR CLEANING AND MAINTAINING SURFACES OF AUTOMOBILES, TRUCK, MOTORCYCLES AND OTHER TRANSPORTATION VEHICLES; PRODUCT DEMONSTRATION; PROMOTING AND SHOWCASING THE GOODS OF OTHERS IN THE FIELD OF PRODUCTS PERTAINING TO CARE AND MAINTENANCE OF AUTOMOBILES, TRUCKS, MOTORCYCLES AND OTHER TRANSPORTATION VEHICLES, TOOLS AND OTHER PRODUCTS FOR MAINTENANCE OF AUTOMOBILES, TRUCKS, MOTORCYCLES AND OTHER TRANSPORTATION VEHICLES, ACCESSORIES AND PARTS FOR AUTOMOBILES, TRUCKS, MOTORCYCLES AND OTHER TRANSPORTATION VEHICLES, MEMORABILIA PERTAINING TO AUTOMOBILES, TRUCKS, MOTORCYCLES AND OTHER TRANSPORTATION VEHICLES, PRODUCTS DESIGNED FOR USE WITH AUTOMOBILES, TRUCK, MOTORCYCLES AND OTHER TRANSPORTATION VEHICLES, FINISHING, CUTTING, AND POLISHING FOR MAINTAINING SURFACES OF AUTOMOBILES, TRUCK, MOTORCYCLES AND OTHER TRANSPORTATION VEHICLES, SANDING DISCS, SHEETS, AND BLOCKS FOR MAINTAINING SURFACES OF AUTOMOBILES, TRUCK, MOTORCYCLES AND OTHER TRANSPORTATION VEHICLES, GRINDING DISCS MAINTAINING SURFACES OF AUTOMOBILES, TRUCK, MOTORCYCLES AND OTHER TRANSPORTATION VEHICLES, BACKING PLATES AND INTERFACE DISCS FOR USE WITH SANDING MACHINES FOR MAINTAINING SURFACES OF AUTOMOBILES, TRUCK, MOTORCYCLES AND OTHER TRANSPORTATION VEHICLES, SANDERS, POLISHERS, SPONGES, DETAILING CLAY, SQUEEGEES, DETAILING CLOTHS, DOME HAND BLOCKS, DENIBBING FILE, AND SANDING PADS FOR MAINTAINING SURFACES OF AUTOMOBILES, TRUCK, MOTORCYCLES AND OTHER TRANSPORTATION VEHICLES, AND CLEANSING AND POLISHING PREPARATIONS FOR CLEANING AND MAINTAINING SURFACES OF AUTOMOBILES, TRUCK, MOTORCYCLES AND OTHER TRANSPORTATION VEHICLES BY MEANS OF AN ON-LINE SHOPPING SITE WITH LINKS TO THE RETAIL ADVERTISEMENTS OF OTHERS; PROMOTING THE GOODS AND SERVICES OF OTHERS BY MEANS OF OPERATING AN ON-LINE SHOPPING MALL WITH LINKS TO THE RETAIL WEB SITES OF OTHERS; PROMOTING THE GOODS AND SERVICES OF OTHERS BY PROVIDING A COMMUNITY-DRIVEN WEB SITE FEATURING USER-SUBMITTED CONTENT IN THE NATURE OF COUPONS, REBATES, PRICE-COMPARISON INFORMATION, PRODUCT REVIEWS, LINKS TO THE RETAIL WEB SITES OF OTHERS, AND DISCOUNT INFORMATION; PROMOTING THE GOODS AND SERVICES OF OTHERS BY PROVIDING A WEBSITE FEATURING COUPONS, REBATES, PRICE-COMPARISON INFORMATION, PRODUCT REVIEWS, LINKS TO THE RETAIL WEBSITES OF OTHERS, AND DISCOUNT INFORMATION; PROMOTING THE GOODS AND SERVICES OF OTHERS BY PROVIDING HYPERTEXT LINKS TO THE WEB SITES OF OTHERS; PROVIDING A WEB SITE FEATURING BUSINESS INFORMATION IN THE FORM OF AUDIO AND VIDEO INTERVIEWS, TRANSCRIPTS AND OTHER EDUCATIONAL MATERIALS; PROVIDING A WEB SITE WHICH FEATURES ADVERTISEMENTS FOR THE GOODS AND SERVICES OF OTHERS ON A GLOBAL COMPUTER NETWORK; PROVIDING INFORMATION ABOUT THE GOODS AND SERVICES OF OTHERS VIA THE GLOBAL COMPUTER NETWORK; PROVIDING SPACE AT A WEB SITE FOR THE ADVERTISEMENT OF THE GOODS AND SERVICES OF OTHERS; RETAIL AUTOMOBILE PARTS AND ACCESSORIES STORES; RETAIL GIFT SHOPS; RETAIL SERVICES THROUGH DIRECT SOLICITATION BY SALESPERSONS DIRECTED TO END-USERS FEATURING PRODUCTS, PERTAINING TO CARE AND MAINTENANCE OF AUTOMOBILES, TRUCKS, MOTORCYCLES AND OTHER TRANSPORTATION VEHICLES, TOOLS AND OTHER PRODUCTS FOR MAINTENANCE OF AUTOMOBILES, TRUCKS, MOTORCYCLES AND OTHER TRANSPORTATION VEHICLES, ACCESSORIES AND PARTS FOR AUTOMOBILES, TRUCKS, MOTORCYCLES AND OTHER TRANSPORTATION VEHICLES, MEMORABILIA PERTAINING TO AUTOMOBILES, TRUCKS, MOTORCYCLES AND OTHER TRANSPORTATION VEHICLES, PRODUCTS DESIGNED FOR USE WITH AUTOMOBILES, TRUCK, MOTORCYCLES AND OTHER TRANSPORTATION VEHICLES, FINISHING, CUTTING, AND POLISHING FOR





HICLES, PRODUCTS DESIGNED FOR USE WITH AUTOMOBILES, TRUCK, MOTORCYCLES AND OTHER TRANSPORTATION VEHICLES, FINISHING, CUTTING, AND POLISHING FOR MAINTAINING SURFACES OF AUTOMOBILES, TRUCK, MOTORCYCLES AND OTHER TRANSPORTATION VEHICLES, SANDING DISCS, SHEETS, AND BLOCKS FOR MAINTAINING SURFACES OF AUTOMOBILES, TRUCK, MOTORCYCLES AND OTHER TRANSPORTATION VEHICLES, GRINDING DISCS MAINTAINING SURFACES OF AUTOMOBILES, TRUCK, MOTORCYCLES AND OTHER TRANSPORTATION VEHICLES, BACKING PLATES AND INTERFACE DISCS FOR USE WITH SANDING MACHINES FOR MAINTAINING SURFACES OF AUTOMOBILES, TRUCK, MOTORCYCLES AND OTHER TRANSPORTATION VEHICLES, SANDERS, POLISHERS, SPONGES, DETAILING CLAY, SQUEEGEES, DETAILING CLOTHS, DOME HAND BLOCKS, DENIBBING FILE, AND SANDING PADS FOR MAINTAINING SURFACES OF AUTOMOBILES, TRUCK, MOTORCYCLES AND OTHER TRANSPORTATION VEHICLES, AND CLEANSING AND POLISHING PREPARATIONS FOR CLEANING AND MAINTAINING SURFACES OF AUTOMOBILES, TRUCK, MOTORCYCLES AND OTHER TRANSPORTATION VEHICLES; WHOLESALE AND RETAIL STORE SERVICES FEATURING PRODUCTS PERTAINING TO CARE AND MAINTENANCE OF AUTOMOBILES, TRUCKS, MOTORCYCLES AND OTHER TRANSPORTATION VEHICLES, TOOLS AND OTHER PRODUCTS FOR MAINTENANCE OF AUTOMOBILES, TRUCKS, MOTORCYCLES AND OTHER TRANSPORTATION VEHICLES, ACCESSORIES AND PARTS FOR AUTOMOBILES, TRUCKS, MOTORCYCLES AND OTHER TRANSPORTATION VEHICLES, MEMORABILIA PERTAINING TO AUTOMOBILES, TRUCKS, MOTORCYCLES AND OTHER TRANSPORTATION VEHICLES, PRODUCTS DESIGNED FOR USE WITH AUTOMOBILES, TRUCK, MOTORCYCLES AND OTHER TRANSPORTATION VEHICLES, FINISHING, CUTTING, AND POLISHING FOR MAINTAINING SURFACES OF AUTOMOBILES, TRUCK, MOTORCYCLES AND OTHER TRANSPORTATION VEHICLES, SANDING DISCS, SHEETS, AND BLOCKS FOR MAINTAINING SURFACES OF AUTOMOBILES, TRUCK, MOTORCYCLES AND OTHER TRANSPORTATION VEHICLES, GRINDING DISCS MAINTAINING SURFACES OF AUTOMOBILES, TRUCK, MOTORCYCLES AND OTHER TRANSPORTATION VEHICLES, BACKING PLATES AND INTERFACE DISCS FOR USE WITH SANDING MACHINES FOR MAINTAINING SURFACES OF AUTOMOBILES, TRUCK, MOTORCYCLES AND OTHER TRANSPORTATION VEHICLES, SANDERS, POLISHERS, SPONGES, DETAILING CLAY, SQUEEGEES, DETAILING CLOTHS, DOME HAND BLOCKS, DENIBBING FILE, AND SANDING PADS FOR MAINTAINING SURFACES OF AUTOMOBILES, TRUCK, MOTORCYCLES AND OTHER TRANSPORTATION VEHICLES, AND CLEANSING AND POLISHING PREPARATIONS FOR CLEANING AND MAINTAINING SURFACES OF AUTOMOBILES, TRUCK, MOTORCYCLES AND OTHER TRANSPORTATION VEHICLES (U.S. CLS. 100, 101 AND 102).

CIMMERIAN COLEMAN, EXAMINING ATTORNEY

SN 85-127,944, SICK AG, 79183 WALDKIRCH, FED REP GERMANY, FILED 9-13-2010.

# HDDM

THE MARK CONSISTS OF STANDARD CHARACTERS WITHOUT CLAIM TO ANY PARTICULAR FONT, STYLE, SIZE, OR COLOR.

PRIORITY CLAIMED UNDER SEC. 44(D) ON ERP NCNTY TM OFC APPLICATION NO. 009014333, FILED 4-8-2010, REG. NO. 009014333, DATED 9-27-2010, EXPIRES 4-8-2020.

## CLASS 9—ELECTRICAL AND SCIENTIFIC APPARATUS

FOR OPTICAL, OPTO-ELECTRONIC AND PHOTO-ELECTRIC SENSORS FOR SENSING LIGHT AND LIGHT REFLECTED BY OBJECTS; LIGHT BARRIERS, LIGHT SCANNERS, SAFETY LIGHT GRIDS AND LIGHT GRIDS FOR MEASURING OBJECT DIMENSIONS; OPTICAL, OPTO-ELECTRONIC, AND PHOTO-ELECTRIC SENSORS FOR USE IN RECOGNIZING THE SHAPE, POSITION, CONTOUR, VOLUME, DISTANCE, TEXTURE OR SURFACE CHARACTERISTICS OF ARTICLES FOR THE PURPOSE OF AUTOMATIC INSPECTION, FOR INSPECTION OF PLAIN OR WEB-LIKE MATERIALS AND CHECKING THE CHARACTERISTICS OF SUCH MATERIALS, FOR FAULT RECOGNITION, FOR AUTOMATIC IDENTIFICATION, QUALITY CONTROL, POSITIONING, HANDLING AND CONTROL OF ARTICLES, AND FOR THE PURPOSE OF AUTOMATION IN THE FIELDS OF MANUFACTURE, QUALITY CONTROL, STORAGE, FLOW OF GOODS, SALES, TRANSPORT, LABORATORY, PLANTS, TRAFFIC, INSTALLATIONS AND PUBLIC BUILDINGS; ELECTRONIC AND/OR OPTICAL SENSORS FOR THE PURPOSE OF MEASURING A POSITION OR LENGTH OR DISTANCE; ELECTRONIC POSITION ENCODERS; OPTICAL SENSORS FOR DISTANCE MEASUREMENTS; OPTICAL, OPTO-ELECTRONIC AND PHOTOELECTRIC SENSORS FOR SENSING LIGHT AND LIGHT REFLECTED BY OBJECTS FOR THE PURPOSE OF SAFETY GUARDING AND MONITORING OF ROOMS, SPACES, POINTS OF DANGER OR DANGER ZONES; SAFETY LIGHT CURTAINS; SCANNERS WORKING ON AN ELECTRONIC BASIS AND IN THE FIELD OF INFRARED, VISIBLE OR ULTRAVIOLET RADIATION; SCANNERS WHICH OPERATE WITH A SCANNING BEAM FOR THE SCANNING OF SPECIFIC SURFACES AND/OR SPATIAL REGIONS (U.S. CLS. 21, 23, 26, 36 AND 38).

## CLASS 37—CONSTRUCTION AND REPAIR

FOR INSTALLATION, MAINTENANCE AND REPAIR OF ELECTRIC, OPTIC AND OPTO-ELECTRONIC APPLIANCES (U.S. CLS. 100, 103 AND 106).

LINDA LAVACHE, EXAMINING ATTORNEY

SN 85-128,550, INTERMOUNTAIN POWER AGENCY, SOUTH JORDAN, UT. FILED 9-13-2010.

INTERMOUNTAIN POWER PROJECT

THE MARK CONSISTS OF STANDARD CHARACTERS WITHOUT CLAIM TO ANY PARTICULAR FONT, STYLE, SIZE, OR COLOR.

NO CLAIM IS MADE TO THE EXCLUSIVE RIGHT TO USE "POWER PROJECT", APART FROM THE MARK AS SHOWN.

## CLASS 39—TRANSPORTATION AND STORAGE

FOR DISTRIBUTION AND TRANSMISSION OF ELECTRICITY (U.S. CLS. 100 AND 105).

FIRST USE 8-1-1973; IN COMMERCE 0-0-1987.

## CLASS 40—MATERIAL TREATMENT

FOR GENERATION OF ELECTRICITY (U.S. CLS. 100, 103 AND 106).

FIRST USE 8-1-1973; IN COMMERCE 0-0-1987.

JACQUELINE A. LAVINE, EXAMINING ATTORNEY

SN 85-128,613. HUMANGEAR, INC., SAN FRANCISCO, CA.  
FILED 9-13-2010.

SN 85-129,627. LOCK77, LLC, EL SEGUNDO, CA. FILED 9-14-2010.

# PAWW

THE MARK CONSISTS OF STANDARD CHARACTERS WITHOUT CLAIM TO ANY PARTICULAR FONT, STYLE, SIZE, OR COLOR.

## CLASS 18—LEATHER GOODS

FOR PET LEASHES AND COLLARS (U.S. CLS. 1, 2, 3, 22 AND 41).

## CLASS 21—HOUSEWARES AND GLASS

FOR PET FEEDING BOWLS AND DISHES; PET TREAT JARS; HOUSEHOLD STORAGE CONTAINERS FOR PET FOOD (U.S. CLS. 2, 13, 23, 29, 30, 33, 40 AND 50).

## CLASS 28—TOYS AND SPORTING GOODS

FOR PET FETCH TOYS; PET TUG TOYS; PET TOYS (U.S. CLS. 22, 23, 38 AND 50).  
KHANH LE, EXAMINING ATTORNEY

---

SN 85-128,728. YOBONGO, INC., SAN FRANCISCO, CA.  
FILED 9-14-2010.

# YOBONGO

THE MARK CONSISTS OF STANDARD CHARACTERS WITHOUT CLAIM TO ANY PARTICULAR FONT, STYLE, SIZE, OR COLOR.

"YOBONGO" APPEARING IN THE MARK HAS NO SIGNIFICANCE NOR IS IT A TERM OF ART IN THE RELEVANT TRADE OR INDUSTRY OR AS APPLIED TO THE GOODS/SERVICES LISTED IN THE APPLICATION, OR ANY GEOGRAPHICAL SIGNIFICANCE.

## CLASS 38—COMMUNICATION

FOR PROVIDING ON-LINE CHAT ROOMS FOR TRANSMISSION OF MESSAGES AMONG USERS IN THE FIELD OF GENERAL INTEREST; PROVIDING ON-LINE CHAT ROOMS FOR SOCIAL NETWORKING; VIRTUAL CHAT ROOMS ESTABLISHED VIA MOBILE PHONES (U.S. CLS. 100, 101 AND 104).

## CLASS 42—SCIENTIFIC AND COMPUTER SERVICES

FOR PROVIDING TEMPORARY USE OF A NON-DOWNLOADABLE SOFTWARE APPLICATION, ACCESSIBLE VIA THE INTERNET AND MOBILE DEVICES, THAT ALLOWS USERS TO CHAT WITH EACH OTHER AND SHARE MESSAGES, PHOTOS, VIDEOS, AND OTHER DIGITAL CONTENT (U.S. CLS. 100 AND 101).  
JOHN E. MICHOS, EXAMINING ATTORNEY

# MassCanvas

THE MARK CONSISTS OF STANDARD CHARACTERS WITHOUT CLAIM TO ANY PARTICULAR FONT, STYLE, SIZE, OR COLOR.

## CLASS 25—CLOTHING

FOR CLOTHING, NAMELY, SHIRTS, BLOUSES, T-SHIRTS, BABY DOLL T-SHIRTS, TANK TOPS, HOODED SHIRTS, HOODED JACKETS, HOODED SWEATSHIRTS, SWEATSHIRTS, JACKETS, PANTS, SHORTS, DRESSES, SKIRTS, BOXER SHORTS, SWIMSUITS, APRONS, BIBS, NECK TIES, ARM BANDS, HEAD BANDS, VISORS, HATS, BASEBALL CAPS, SKI CAPS, SOCKS, SHOES, FLIP FLOPS, AND FOOTWEAR (U.S. CLS. 22 AND 39).

## CLASS 35—ADVERTISING AND BUSINESS

FOR ONLINE RETAIL STORE SERVICES FEATURING CUSTOMIZED T-SHIRTS, SWEATSHIRTS, BABY DOLL T-SHIRTS, BASEBALL CAPS, COFFEE MUGS, MOUSE PADS, TOTE BAGS, MESSENGER BAGS, COMPACT DISCS, CD-ROMS, TANK TOPS, VISORS, BOXER SHORTS, FLYING DISCS, GREETING CARDS, POSTCARDS, CALENDARS, WALL CLOCKS, COASTERS, SKI CAPS, APRONS, TEDDY BEARS, LICENSE PLATE FRAMES, CLOTH BIBS, PICTURE FRAMES, STICKERS, BUMPER STICKERS, POSTERS AND GENERAL CONSUMER GOODS; ADVERTISING AND MARKETING SERVICES, NAMELY, PROMOTING THE GOODS AND SERVICES OF OTHERS; SPECIALTY MERCHANDISING SERVICES, NAMELY, PROMOTING THE GOODS AND SERVICES OF OTHERS THROUGH THE DISTRIBUTION OF CUSTOMIZED ADVERTISING MATERIALS, NAMELY, CUSTOMIZED T-SHIRTS, SWEATSHIRTS, BABY DOLL T-SHIRTS, BASEBALL CAPS, COFFEE MUGS, MOUSE PADS, TOTE BAGS, MESSENGER BAGS, COMPACT DISCS, CD-ROMS, TANK TOPS, VISORS, BOXER SHORTS, FLYING DISCS, GREETING CARDS, POSTCARDS, CALENDARS, WALL CLOCKS, COASTERS, SKI CAPS, APRONS, TEDDY BEARS, LICENSE PLATE FRAMES, BIBS, PICTURE FRAMES, STICKERS, BUMPER STICKERS AND POSTERS; COMPUTERIZED ON-LINE RETAIL STORES FEATURING CUSTOMIZED T-SHIRTS, SWEATSHIRTS, BABY DOLL T-SHIRTS, BASEBALL CAPS, COFFEE MUGS, MOUSE PADS, TOTE BAGS, MESSENGER BAGS, COMPACT DISCS, CD-ROMS, TANK TOPS, VISORS, BOXER SHORTS, FLYING DISCS, GREETING CARDS, POSTCARDS, CALENDARS, WALL CLOCKS, COASTERS, SKI CAPS, APRONS, TEDDY BEARS, LICENSE PLATE FRAMES, BIBS, PICTURE FRAMES, STICKERS, BUMPER STICKERS AND POSTERS (U.S. CLS. 100, 101 AND 102).

**CLASS 42—SCIENTIFIC AND COMPUTER SERVICES**

FOR COMPUTER SERVICES, NAMELY, CREATING AN ON-LINE COMMUNITY FOR REGISTERED USERS TO PARTICIPATE IN DISCUSSIONS, GET FEEDBACK FROM THEIR PEERS, FORM VIRTUAL COMMUNITIES, AND ENGAGE IN SOCIAL NETWORKING FEATURING FORUMS FOR SUBMISSION OF ARTISTIC DESIGNS AND DISCUSSION OF THOSE DESIGNS; COMPUTER SERVICES, NAMELY, CREATING AN ON-LINE COMMUNITY FOR REGISTERED USERS TO PARTICIPATE IN COMPETITIONS, SHOWCASE THEIR SKILLS, GET FEEDBACK FROM THEIR PEERS, FORM VIRTUAL COMMUNITIES, ENGAGE IN SOCIAL NETWORKING AND IMPROVE THEIR TALENT; HOSTING AN ON-LINE COMMUNITY WEB SITE FOR OTHERS FEATURING FORUMS FOR SUBMISSION OF ARTISTIC DESIGNS AND DISCUSSION OF THOSE DESIGNS; HOSTING AN ON-LINE COMMUNITY WEB SITE FOR OTHERS FEATURING ARTISTIC DESIGNS, USERS, AND CONTRIBUTORS IN THE FORM OF WRITTEN, PICTORIAL, AND VIDEO CONTENT (U.S. CLS. 100 AND 101).

KATHERINE STOIDES, EXAMINING ATTORNEY

SN 85-129,780. DISCOUNT SATELLITE NAVIGATION LIMITED, CRAWLEY, UNITED KINGDOM, FILED 9-15-2010.

**DURAGADGET**

THE MARK CONSISTS OF STANDARD CHARACTERS WITHOUT CLAIM TO ANY PARTICULAR FONT, STYLE, SIZE, OR COLOR.

OWNER OF ERPN CMNTY TM OFC REG. NO. 008997231, DATED 8-24-2010, EXPIRES 3-31-2020.

**CLASS 9—ELECTRICAL AND SCIENTIFIC APPARATUS**

FOR CARRIERS, CASES, BAGS AND HOLDERS ADAPTED FOR MOBILE PHONES, PERSONAL DIGITAL ASSISTANTS (PDAS), ELECTRONIC ORGANIZERS, LAPTOPS, SATELLITE NAVIGATION EQUIPMENT, MP3 AND MP4 PLAYERS, COMPUTERS AND DATA PROCESSING APPARATUS, APPARATUS FOR RECORDING, TRANSMISSION OR REPRODUCTION OF SOUND AND/OR IMAGES; PARTS AND FITTINGS FOR MOBILE PHONES; TELECOMMUNICATIONS APPARATUS AND EQUIPMENT INCLUDING PARTS AND FITTINGS THEREFOR, NAMELY, TELEPHONES AND MOBILE PHONES; SATELLITE NAVIGATION SYSTEMS INCLUDING PARTS AND FITTINGS, NAMELY, A GLOBAL POSITIONING SYSTEM; COMPUTER HARDWARE INCLUDING PARTS AND FITTINGS; BATTERIES; RECHARGEABLE BATTERIES; CHARGERS; CHARGERS FOR ELECTRIC BATTERIES; SCREEN PROTECTORS ADAPTED FOR MOBILE PHONES, PERSONAL DIGITAL ASSISTANTS (PDAS), LAPTOPS, SATELLITE NAVIGATION EQUIPMENT, NAMELY, A GLOBAL POSITIONING SYSTEM, MP3 AND MP4 PLAYERS, COMPUTERS AND DATA PROCESSING APPARATUS, APPARATUS FOR RECORDING, TRANSMISSION OR REPRODUCTION OF SOUND AND/OR IMAGES; WINDSCREEN MOUNTS FOR MOBILE PHONES, PERSONAL DIGITAL ASSISTANTS (PDAS), LAPTOPS, SATELLITE NAVIGATION EQUIPMENT, NAMELY, A GLOBAL POSITIONING SYSTEM; MP3 AND MP4 PLAYERS, COMPUTERS AND DATA PROCESSING APPARATUS, APPARATUS FOR RECORDING, TRANSMISSION OR REPRODUCTION OF SOUND AND/OR IMAGES; CABLES FOR USE WITH COMPUTERS, DATA PROCESSING APPARATUS, APPARATUS FOR RECORDING, TRANSMISSION OR REPRODUCTION OF SOUND AND/OR IMAGES; USB CABLES; COMPUTER STYLI OR STYLUSES FOR USE WITH PERSONAL DIGITAL ASSISTANTS, ELECTRONIC ORGANIZERS AND/OR COMPUTERS; HEADPHONES; STEREO HEADPHONES; IN-EAR HEADPHONES; STEREO SPEAKERS; AUDIO SPEAKERS; DOCKING CRADLES FOR USE WITH MOBILE PHONES, PERSONAL DIGITAL ASSISTANTS (PDAS), ELECTRONIC ORGANIZERS, LAPTOPS, SATELLITE NAVIGATION EQUIPMENT, MP3 AND MP4 PLAYERS, COMPUTERS AND DATA PROCESSING APPARATUS, APPARATUS FOR RECORDING, TRANSMISSION OR REPRODUCTION OF SOUND AND/OR IMAGES; PARTS AND FITTINGS FOR ALL THE ABOVE (U.S. CLS. 21, 23, 26, 36 AND 38).

**CLASS 35—ADVERTISING AND BUSINESS**

FOR ON-LINE WHOLESALE AND RETAIL STORE SERVICES, AND MAIL ORDER SERVICES FEATURING CARRIERS, CASES, BAGS AND HOLDERS ADAPTED FOR MOBILE PHONES, PERSONAL DIGITAL ASSISTANTS (PDAS), ELECTRONIC ORGANIZERS, LAPTOPS, SATELLITE NAVIGATION EQUIPMENT, MP3 AND MP4 PLAYERS, COMPUTERS AND DATA PROCESSING APPARATUS, APPARATUS FOR RECORDING, TRANSMISSION OR REPRODUCTION OF SOUND AND/OR IMAGES; PARTS AND FITTINGS FOR MOBILE PHONES; TELECOMMUNICATIONS APPARATUS AND EQUIPMENT INCLUDING PARTS AND FITTINGS THEREFOR, NAMELY, TELEPHONES AND MOBILE PHONES; APPARATUS, EQUIPMENT AND DEVICES FOR RECORDING, TRANSMISSION AND/OR REPRODUCTION OF SOUNDS, IMAGES OR OTHER DATA INCLUDING PARTS AND FITTINGS, NAMELY, CAMCORDERS AND CAMERAS; SATELLITE NAVIGATION SYSTEMS INCLUDING PARTS AND FITTINGS, NAMELY, A GLOBAL POSITIONING SYSTEM; COMPUTER HARDWARE INCLUDING PARTS AND FITTINGS; BATTERIES; RECHARGEABLE BATTERIES; CHARGERS; CHARGERS FOR ELECTRIC BATTERIES; SCREEN PROTECTORS ADAPTED FOR MOBILE PHONES, PERSONAL DIGITAL ASSISTANTS (PDAS), LAPTOPS, SATELLITE NAVIGATION EQUIPMENT, NAMELY, A GLOBAL POSITIONING SYSTEM; MP3 AND MP4 PLAYERS, COMPUTERS AND DATA PROCESSING APPARATUS, APPARATUS FOR RECORDING, TRANSMISSION OR REPRODUCTION OF SOUND AND/OR IMAGES; WINDSCREEN MOUNTS FOR MOBILE PHONES, PERSONAL DIGITAL ASSISTANTS (PDAS), LAPTOPS, SATELLITE NAVIGATION

EQUIPMENT, MP3 AND MP4 PLAYERS, COMPUTERS AND DATA PROCESSING APPARATUS, APPARATUS FOR RECORDING, TRANSMISSION OR REPRODUCTION OF SOUND AND/OR IMAGES; CABLES FOR USE WITH COMPUTERS, DATA PROCESSING APPARATUS, APPARATUS FOR RECORDING, TRANSMISSION OR REPRODUCTION OF SOUND AND/OR IMAGES; USB CABLES; COMPUTER STYLI OR STYLUSES FOR USE WITH PERSONAL DIGITAL ASSISTANTS, ELECTRONIC ORGANIZERS AND/OR COMPUTERS; HEADPHONES; STEREO HEADPHONES; IN-EAR HEADPHONES; STEREO SPEAKERS; AUDIO SPEAKERS; DOCKING CRADLES FOR USE WITH MOBILE PHONES, PERSONAL DIGITAL ASSISTANTS (PDAS), ELECTRONIC ORGANIZERS, LAPTOPS, SATELLITE NAVIGATION EQUIPMENT, MP3 AND MP4 PLAYERS, COMPUTERS AND DATA PROCESSING APPARATUS, APPARATUS FOR RECORDING, TRANSMISSION OR REPRODUCTION OF SOUND AND/OR IMAGES; PARTS AND FITTINGS FOR ALL THE ABOVE (U.S. CLS. 100, 101 AND 102).

SCOTT BIBB, EXAMINING ATTORNEY

SN 85-132,947. TERRY PRECISION BICYCLES FOR WOMEN, INC., BURLINGTON, VT. FILED 9-19-2010.

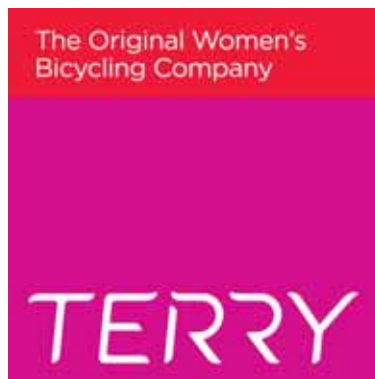

SN 85-131,931. GREENSBORO PREGNANCY CARE CENTER, INC., GREENSBORO, NC. FILED 9-17-2010.

### MAKE UP YOUR OWN MIND

THE MARK CONSISTS OF STANDARD CHARACTERS WITHOUT CLAIM TO ANY PARTICULAR FONT, STYLE, SIZE, OR COLOR.

#### CLASS 41—EDUCATION AND ENTERTAINMENT

FOR EDUCATIONAL SERVICES, NAMELY, PROVIDING INSTRUCTION IN THE FIELDS OF ABSTINENCE, RELATIONSHIPS, PREGNANCY, SEXUAL HEALTH AND SEXUALLY-TRANSMITTED DISEASES, ABORTION RISKS AND ALTERNATIVES, ABORTION RECOVERY SERVICES; EDUCATIONAL SERVICES, NAMELY, PROVIDING RELIGIOUS INSTRUCTION PROMOTING CHRISTIAN AND FAMILY VALUES AND BIBLE STUDY; EDUCATIONAL SERVICES, NAMELY, PROVIDING INSTRUCTION IN THE FIELD OF PARENTING (U.S. CLS. 100, 101 AND 107).

FIRST USE 8-25-2010; IN COMMERCE 8-25-2010.

#### CLASS 44—MEDICAL, BEAUTY AND AGRICULTURAL SERVICES

FOR PROVIDING INFORMATION AND COUNSELING RELATING TO ABORTION RISKS AND ALTERNATIVES; PEER COUNSELING SERVICES RELATING TO PREGNANCY HEALTH; PEER COUNSELING SERVICES IN RELATION TO SEXUALLY TRANSMITTED DISEASES AND INFECTIONS; PREGNANCY TESTING SERVICES; MEDICAL IMAGING SERVICES, NAMELY, ULTRASOUND (U.S. CLS. 100 AND 101).

FIRST USE 8-25-2010; IN COMMERCE 8-25-2010.

#### CLASS 45—PERSONAL AND LEGAL SERVICES

FOR PROVIDING INFORMATION AND COUNSELING RELATING TO ADOPTIONS; PEER COUNSELING SERVICES FOR EMOTIONAL ABORTION RECOVERY (U.S. CLS. 100 AND 101).

FIRST USE 8-25-2010; IN COMMERCE 8-25-2010.  
SUNG IN, EXAMINING ATTORNEY

NO CLAIM IS MADE TO THE EXCLUSIVE RIGHT TO USE "ORIGINAL WOMEN'S BICYCLING COMPANY", APART FROM THE MARK AS SHOWN.

THE COLOR(S) ORANGE, WHITE AND PINK IS/ARE CLAIMED AS A FEATURE OF THE MARK.

THE MARK CONSISTS OF A RECTANGLE CONSISTING OF AN UPPER ORANGE RECTANGULAR REGION WITHIN WHICH THE FOLLOWING WORDS ARE CONTAINED IN WHITE BLOCK LETTERS WITH INITIAL CAPS: "THE ORIGINAL WOMEN'S BICYCLING COMPANY" AND A SECOND LOWER PINK RECTANGULAR REGION WITH THE WORD "TERRY" AT ITS BOTTOM IN WHITE SCRIPT WITH THE SECOND "R" MISSING ITS VERTICAL BAR.

#### CLASS 25—CLOTHING

FOR BICYCLE GLOVES; BICYCLING GLOVES; BOILEROS; BRAS; CLOTHING FOR ATHLETIC USE, NAMELY, PADDED SHORTS; CLOTHING, NAMELY, BASE LAYERS; CYCLING SHOES; CYCLISTS' JERSEYS; GLOVES; KNICKERS; LADIES' UNDERWEAR; LEGGINGS; PERSPIRATION ABSORBENT UNDERWEAR CLOTHING; RIDING GLOVES; SHORTS; SKORTS; SPORTS BRAS; TANK TOPS; TIGHTS; UNDERWEAR; WOMEN'S UNDERWEAR (U.S. CLS. 22 AND 39).

#### CLASS 35—ADVERTISING AND BUSINESS

FOR WHOLESALE AND RETAIL STORE SERVICES AND ON-LINE RETAIL AND WHOLESALE STORE SERVICES FEATURING CYCLING ACCESSORIES, NAMELY, HELMETS, EYEGLASSES, SADDLE BAGS, PANNIERS AND APPAREL; MAIL ORDER CATALOG SERVICES FEATURING CYCLING ACCESSORIES, NAMELY, HELMETS, EYEGLASSES, SADDLE BAGS, PANNIERS AND APPAREL (U.S. CLS. 100, 101 AND 102).

CHARLES L. JENKINS, EXAMINING ATTORNEY

SN 85-133,293. SYMPOZ, INC., DENVER, CO. FILED 9-20-2010.

# SYMPOZ

THE MARK CONSISTS OF STANDARD CHARACTERS WITHOUT CLAIM TO ANY PARTICULAR FONT, STYLE, SIZE, OR COLOR.

**CLASS 9—ELECTRICAL AND SCIENTIFIC APPARATUS**

FOR COMPUTER SOFTWARE FOR GENERATING ONLINE COURSES OF INSTRUCTION IN THE FIELDS OF EDUCATION AND TRAINING; COMPUTER SOFTWARE FOR CONNECTING COMPUTER NETWORK USERS FOR USE IN THE FIELD OF ONLINE AND WEB-BASED LEARNING; COMPUTER SOFTWARE FOR THE CREATION AND DELIVERY OF COURSES OF INSTRUCTION IN THE FIELDS OF EDUCATION AND TRAINING VIA A GLOBAL COMPUTER INFORMATION NETWORK; COMPUTER SOFTWARE FOR GENERATING ONLINE COURSES OF INSTRUCTION, CREATING AND ADMINISTERING ONLINE EDUCATIONAL INTERACTIVE DISCUSSION FORUMS, CREATING WEBSITES IN THE FIELDS OF ONLINE EDUCATION AND TRAINING, CREATING AND ADMINISTERING ELECTRONIC DATABASES OF EDUCATIONAL COURSE CONTENT, ONLINE PORTAL SERVICES, NAMELY, PROVIDING CUSTOMIZED ONLINE RESOURCES, TOOLS, AND BULLETIN BOARDS, ALL IN THE FIELDS OF EDUCATION AND TRAINING (U.S. CLS. 21, 23, 26, 36 AND 38).

**CLASS 41—EDUCATION AND ENTERTAINMENT**

FOR EDUCATION SERVICES, NAMELY, PROVIDING A WEB SITE FEATURING COURSE LECTURES, AUDIO, VIDEO AND PROSE PRESENTATIONS IN THE FIELDS OF ALL COURSES OF STUDY OFFERED BY COLLEGES, UNIVERSITIES, AND INSTITUTIONS OF HIGHER EDUCATION, AND DISTRIBUTING COURSE MATERIAL IN CONNECTION THEREWITH; ONLINE ELECTRONIC PUBLISHING OF BOOKS AND PERIODICALS; PROVIDING AN ON-LINE COMPUTER DATABASE FEATURING INFORMATION IN THE FIELDS OF EDUCATION AND TRAINING (U.S. CLS. 100, 101 AND 107).

**CLASS 42—SCIENTIFIC AND COMPUTER SERVICES**

FOR DESIGN OF COMPUTER SOFTWARE; INSTALLATION OF COMPUTER SOFTWARE; MAINTENANCE OF COMPUTER SOFTWARE; COMPUTER SERVICES, NAMELY, PROVIDING ON-LINE NON-DOWNLOADABLE EDUCATION PLATFORM SOFTWARE FOR PROVIDING INTERACTIVE ONLINE COURSES, CLASSES, PROGRAMS, SEMINARS AND WORKSHOPS IN THE FIELDS OF EDUCATION AND TRAINING; NON-DOWNLOADABLE WEB-BASED EDUCATIONAL SOFTWARE PLATFORM USED FOR ONLINE EDUCATION AND TRAINING (U.S. CLS. 100 AND 101).  
HENRY S. ZAK, EXAMINING ATTORNEY

SN 85-134,223. BETTER THAN BEST PET AFTER-CARE, LLC, NAPLES, FL. FILED 9-21-2010.

**BETTER THAN BEST PET AFTER-CARE**

THE MARK CONSISTS OF STANDARD CHARACTERS WITHOUT CLAIM TO ANY PARTICULAR FONT, STYLE, SIZE, OR COLOR.

NO CLAIM IS MADE TO THE EXCLUSIVE RIGHT TO USE "PET AFTER-CARE", APART FROM THE MARK AS SHOWN.

**CLASS 35—ADVERTISING AND BUSINESS**

FOR ONLINE RETAIL STORE SERVICES FEATURING PET PRODUCTS (U.S. CLS. 100, 101 AND 102).

**CLASS 36—INSURANCE AND FINANCIAL**

FOR PET INSURANCE SERVICES (U.S. CLS. 100, 101 AND 102).

**CLASS 42—SCIENTIFIC AND COMPUTER SERVICES**

FOR PROVIDING ON-LINE NON-DOWNLOADABLE SOFTWARE FOR USE IN AUDITING, VIDEO SURVEILLANCE, QUALITY ASSURANCE, QUALITY CONTROL AND VERIFICATION, PAYMENT AND ORDER PROCESSING, MONITORING OF PROCESSES, ALL IN THE FIELD OF PET CREMATION (U.S. CLS. 100 AND 101).  
KEVON CHISOLM, EXAMINING ATTORNEY

SN 85-135,875. THE OHIO CASUALTY INSURANCE COMPANY, FAIRFIELD, OH. FILED 9-22-2010.

**OHIO CASUALTY**

THE MARK CONSISTS OF STANDARD CHARACTERS WITHOUT CLAIM TO ANY PARTICULAR FONT, STYLE, SIZE, OR COLOR.

NO CLAIM IS MADE TO THE EXCLUSIVE RIGHT TO USE "CASUALTY", APART FROM THE MARK AS SHOWN. SEC. 2(F).

**CLASS 35—ADVERTISING AND BUSINESS**

FOR ADVERTISING, PROMOTIONAL, MARKETING AND BUSINESS CONSULTING SERVICES FOR OTHERS IN THE FIELD OF INSURANCE (U.S. CLS. 100, 101 AND 102).

FIRST USE 2-0-2008; IN COMMERCE 2-0-2008.

**CLASS 36—INSURANCE AND FINANCIAL**

FOR INSURANCE SERVICES, NAMELY, INSURANCE UNDERWRITING AND ADMINISTRATION OF COMMERCIAL PROPERTY AND CASUALTY INSURANCE; INSURANCE BROKERAGE SERVICES; PROPERTY AND CASUALTY LOSS MANAGEMENT AND CLAIMS ADJUSTMENT SERVICES; INSURANCE CLAIMS ADMINISTRATION AND ADJUSTMENT SERVICES PROVIDED AS PART OF INSURED OR SELF-INSURANCE PROGRAMS; APPRAISAL, CONSULTING, AND ANALYTICAL SERVICES IN THE FIELDS OF MEDICAL, DISABILITY, PROPERTY AND CASUALTY INSURANCE CLAIMS; INSURANCE INFORMATION, MANAGEMENT, AND CONSULTANCY SERVICES; FINANCIAL SPONSORSHIP OF CHARITABLE, SPORTS AND COMMUNITY-CENTERED EVENTS; AND PROVISION OF THE ABOVE-LISTED SERVICES ON-LINE FROM A COMPUTER DATABASE OR VIA THE INTERNET (U.S. CLS. 100, 101 AND 102).

FIRST USE 0-0-1954; IN COMMERCE 0-0-1954.  
REGINA DRUMMOND, EXAMINING ATTORNEY

SN 85-136,690. OPUS DELI, INC, BERKELEY, CA. FILED 9-23-2010.

# Deli.net

THE MARK CONSISTS OF STANDARD CHARACTERS WITHOUT CLAIM TO ANY PARTICULAR FONT, STYLE, SIZE, OR COLOR.

## CLASS 9—ELECTRICAL AND SCIENTIFIC APPARATUS

FOR COMPUTER SOFTWARE FEATURING MUSICAL SOUND RECORDINGS AND MUSICAL VIDEO RECORDINGS; COMPUTER SOFTWARE FOR PROCESSING DIGITAL MUSIC FILES; COMPUTER SOFTWARE FOR USE IN AUTHORIZING, DOWNLOADING, TRANSMITTING, RECEIVING, EDITING, EXTRACTING, ENCODING, DECODING, PLAYING, STORING AND ORGANIZING AUDIO, VIDEO, GRAPHICS, TEXT AND OTHER DATA; COMPUTER SOFTWARE FOR THE STREAMING TRANSMISSION OF AUDIO, VIDEO, GRAPHICS, TEXT AND OTHER DATA OVER COMMUNICATIONS NETWORKS; COMPUTER STORAGE SOFTWARE TO ENABLE COMMUNICATIONS AMONG COMPUTER OR COMMUNICATIONS NETWORK USERS (U.S. CLS. 21, 23, 26, 36 AND 38).

## CLASS 35—ADVERTISING AND BUSINESS

FOR CUSTOMER RELATIONSHIP MANAGEMENT SERVICES IN THE NATURE OF FAN RELATIONSHIP MANAGEMENT SERVICES; DATABASE MANAGEMENT OF FAN LISTS; BUSINESS DEVELOPMENT SERVICES IN THE FIELD OF MUSIC, NAMELY, PROVIDING START-UP SUPPORT FOR BUSINESSES OF OTHERS IN THE FIELD OF PROMOTING, SELLING, AND DISTRIBUTING MUSIC, MUSIC SERVICES, AND MUSIC-RELATED MERCHANDISE (U.S. CLS. 100, 101 AND 102).

## CLASS 38—COMMUNICATION

FOR AUDIO AND VIDEO BROADCASTING SERVICES OVER THE INTERNET IN THE FIELD OF MUSIC; TELECOMMUNICATION SERVICES, NAMELY, ELECTRONIC TRANSMISSION OF STREAMED AND DOWNLOADABLE AUDIO, VIDEO AND DATA FILES VIA COMPUTER AND OTHER COMMUNICATIONS NETWORKS; PROVIDING AN ONLINE FORUM FOR THE TRANSMISSION OF MESSAGES AMONG USERS CONCERNING ENTERTAINMENT, MUSIC, CONCERTS, VIDEOS, RADIO, TELEVISION, FILM, NEWS, SPORTS, GAMES, CURRENT AND CULTURAL EVENTS, PERFORMANCES, ARTS, LEISURE AND OTHER INFORMATION; DELIVERY OF MESSAGES BY ELECTRONIC TRANSMISSION (U.S. CLS. 100, 101 AND 104).

## CLASS 41—EDUCATION AND ENTERTAINMENT

FOR PROVIDING A WEBSITE FEATURING INFORMATION IN THE FIELD OF MUSIC AND ENTERTAINMENT; ENTERTAINMENT SERVICES, NAMELY, PROVIDING NON-DOWNLOADABLE PRE-RECORDED MUSIC, INFORMATION IN THE FIELD OF MUSIC, AND COMMENTARY AND ARTICLES ABOUT MUSIC, ALL ON-LINE VIA A GLOBAL COMPUTER NETWORK; ENTERTAINMENT SERVICES, NAMELY, PROVIDING A WEBSITE FEATURING AUDIO, VIDEO AND PROSE PRESENTATIONS FEATURING MUSIC (U.S. CLS. 100, 101 AND 107).

## CLASS 42—SCIENTIFIC AND COMPUTER SERVICES

FOR COMPUTER SERVICES, NAMELY, HOSTING ON-LINE WEB FACILITIES FOR OTHERS TO SHOW-CASE SONGWRITING AND MUSICAL TALENTS; PROVIDING A WEBSITE THAT GIVES COMPUTER USERS THE ABILITY TO PURCHASE DOWNLOADABLE MUSIC; PROVIDING A WEBSITE THAT GIVES COMPUTER USERS THE ABILITY TO VOTE FOR THEIR FAVORITE MUSICAL ARTISTS; COMPUTER SERVICES, NAMELY, CREATING AN ON-LINE COMMUNITY FOR REGISTERED USERS TO PARTICIPATE IN DISCUSSIONS, GET FEEDBACK FROM THEIR PEERS, FROM VIRTUAL COMMUNITIES, AND ENGAGE IN SOCIAL NETWORKING (U.S. CLS. 100 AND 101).

## CLASS 45—PERSONAL AND LEGAL SERVICES

FOR INTERNET-BASED SOCIAL NETWORKING SERVICES; PROVIDING ON-LINE COMPUTER DATABASES AND ON-LINE SEARCHABLE DATABASES IN THE FIELD OF SOCIAL NETWORKING (U.S. CLS. 100 AND 101).

KATINA MISTER, EXAMINING ATTORNEY

SN 85-137,411. ON DEMAND TECHNOLOGIES, LLC, OVERLAND PARK, KS. FILED 9-24-2010.

## ON DEMAND TECHNOLOGIES

THE MARK CONSISTS OF STANDARD CHARACTERS WITHOUT CLAIM TO ANY PARTICULAR FONT, STYLE, SIZE, OR COLOR.

SEC. 2(F).

## CLASS 35—ADVERTISING AND BUSINESS

FOR PHOTOCOPYING AND DOCUMENT REPRODUCTION SERVICES (U.S. CLS. 100, 101 AND 102).  
FIRST USE 5-0-1995; IN COMMERCE 5-0-1995.

## CLASS 39—TRANSPORTATION AND STORAGE

FOR TEMPORARY ELECTRONIC STORAGE OF DATA; DISTRIBUTION SERVICES, NAMELY, DELIVERY OF DOCUMENTS (U.S. CLS. 100 AND 105).

FIRST USE 5-0-1995; IN COMMERCE 5-0-1995.

RONALD MCMORROW, EXAMINING ATTORNEY

SN 85-137,735. KIDS LINE, LLC, SOUTH GATE, CA. FILED 9-24-2010.



The logo for "KIDSLINE" features the word "kdsline" in a lowercase, sans-serif font. Above the letter "d", there is a stylized graphic of a child's head with pigtail-like hair.

OWNER OF U.S. REG. NO. 3,362,374.  
NO CLAIM IS MADE TO THE EXCLUSIVE RIGHT TO USE "KIDSLINE", APART FROM THE MARK AS SHOWN.  
THE MARK CONSISTS OF THE WORD "KIDSLINE" WITH A CHILDLIKE FIGURE FEATURING A HEAD, WITH PIGTAILS, BODY, ARMS AND FEET COMPRISING THE "I" IN "KIDSLINE".

#### CLASS 7—MACHINERY

FOR ELECTRIC FOOD BLENDERS (U.S. CLS. 13, 19, 21, 23, 31, 34 AND 35).

#### CLASS 9—ELECTRICAL AND SCIENTIFIC APPARATUS

FOR ELECTRIC SWITCH PLATES; THERMOMETERS, ELECTRONIC TIMERS (U.S. CLS. 21, 23, 26, 36 AND 38).

#### CLASS 11—ENVIRONMENTAL CONTROL APPARATUS

FOR LIGHTING DEVICES AND ACCESSORIES, NAMELY, LAMPS, LAMP BASES, LAMP SHADES, AND ELECTRIC NIGHTLIGHTS; ELECTRIC FOOD STEAMERS; ELECTRIC HEATERS FOR BABY BOTTLES; BABY BOTTLE STERILIZERS (U.S. CLS. 13, 21, 23, 31 AND 34).

#### CLASS 16—PAPER GOODS AND PRINTED MATTER

FOR BOOKENDS (U.S. CLS. 2, 5, 22, 23, 29, 37, 38 AND 50).

#### CLASS 20—FURNITURE AND ARTICLES NOT OTHERWISE CLASSIFIED

FOR INFANT AND CHILDREN'S BEDDING AND ACCESSORIES, NAMELY, TEXTILE HEADRESTS FOR BEDS, PILLOWS, PICTURE FRAMES, CHAIR PADS, BED HEADBOARDS (U.S. CLS. 2, 13, 22, 25, 32 AND 50).

#### CLASS 21—HOUSEWARES AND GLASS

FOR BASKETS OF WICKER, STRAW, WOOD AND CLOTH; LAUNDRY HAMPERS FOR DOMESTIC OR HOUSEHOLD USE (U.S. CLS. 2, 13, 23, 29, 30, 33, 40 AND 50).

#### CLASS 24—FABRICS

FOR INFANT AND CHILDREN'S BEDDING AND ACCESSORIES, NAMELY, BLANKETS, COMFORTERS, QUILTS, FABRIC VALANCES, FABRIC DRAPES, DUST RUFFLES, SHEETS, TEXTILE WALL HANGINGS; BASSINET BEDDING, NAMELY, BASSINET CANOPIES, BASSINET FITTED SHEETS, BASSINET SKIRTS, CRIB AND CRADLE CANOPIES; CRIB BEDDING SETS, NAMELY, COMFORTERS, QUILTS, FABRIC VALANCES, FABRIC DRAPES, DUST RUFFLES, SHEETS, BUMPERS; FULL BEDDING SETS, NAMELY, COMFORTERS, QUILTS, FABRIC VALANCES, FABRIC DRAPES, DUST RUFFLES, SHEETS, PILLOW SHAMS; CRADLE BEDDING SETS, NAMELY, COMFORTERS, QUILTS, BUMPERS, SHEETS; BATH TOWELS, HOODED TOWELS, AND FACE CLOTHS FOR WASHING; FABRIC DIAPER STACKERS (U.S. CLS. 42 AND 50).

WILLIAM VERHOSEK, EXAMINING ATTORNEY

SN 85-139,539. AMERICAN PUBLIC POWER ASSOCIATION, WASHINGTON, DC. FILED 9-28-2010.



The logo for "APPA Academy" features the word "APPA" in a bold, sans-serif font with a starburst graphic behind the second "P". To the right, the word "Academy" is written in a script font. Below the logo, the tagline "Where Power and Knowledge Meet" is written in a smaller, sans-serif font.

OWNER OF U.S. REG. NO. 1,760,513.  
THE MARK CONSISTS OF THE LETTERS "APPAACADEMY", WITH A RAY OF LIGHT SHINING FROM THE SECOND "P", ABOVE THE WORDS "WHERE POWER AND KNOWLEDGE MEET".

#### CLASS 38—COMMUNICATION

FOR COMPUTER SERVICES, NAMELY, PROVIDING ON-LINE LISTSERVICES FOR TRANSMISSION OF MESSAGES AMONG COMPUTER USERS CONCERNING PUBLIC POWER AND UTILITIES (U.S. CLS. 100, 101 AND 104).

FIRST USE 9-1-2010; IN COMMERCE 9-1-2010.

#### CLASS 41—EDUCATION AND ENTERTAINMENT

FOR EDUCATIONAL SERVICES, NAMELY, DEVELOPING, ARRANGING, AND CONDUCTING EDUCATIONAL CONFERENCES, PROGRAMS, AND WORKSHOPS IN THE FIELD OF PUBLIC POWER AND UTILITIES; EDUCATIONAL SERVICES, NAMELY, PROVIDING LIVE AND ON-LINE CLASSES AND SEMINARS IN THE FIELD OF PUBLIC POWER AND UTILITIES AND DISTRIBUTION OF COURSE MATERIALS IN CONNECTION THEREWITH; EDUCATIONAL SERVICES, NAMELY, PROVIDING CONTINUING PROFESSIONAL EDUCATION COURSES IN THE FIELD OF PUBLIC POWER AND UTILITIES; PROVIDING CONTINUING LEGAL EDUCATION COURSES; EDUCATIONAL SERVICES, NAMELY, CONDUCTING INTERNET WEBINARS IN THE FIELD OF PUBLIC POWER AND UTILITIES (U.S. CLS. 100, 101 AND 107).

FIRST USE 9-1-2010; IN COMMERCE 9-1-2010.  
MEGHAN REINHART, EXAMINING ATTORNEY



SN 85-139,660. GENERAL MILLS IP HOLDINGS II, LLC,  
MINNEAPOLIS, MN. FILED 9-28-2010.

SN 85-140,541. ROBOTEX INC., PALO ALTO, CA. FILED 9-  
29-2010.

## FIBER ONE

THE MARK CONSISTS OF STANDARD CHARACTERS WITHOUT CLAIM TO ANY PARTICULAR FONT, STYLE, SIZE, OR COLOR.

OWNER OF U.S. REG. NOS. 1,335,787, 3,554,995 AND OTHERS.

NO CLAIM IS MADE TO THE EXCLUSIVE RIGHT TO USE "FIBER", APART FROM THE MARK AS SHOWN.

### CLASS 29—MEATS AND PROCESSED FOODS

FOR POWDERED MIXES USED IN THE PREPARATION OF DAIRY BASED BEVERAGES (U.S. CL. 46).

### CLASS 32—LIGHT BEVERAGES

FOR NON-ALCOHOLIC FRUIT JUICE BEVERAGES; POWDERED MIXES USED IN THE PREPARATION OF FRUIT DRINKS AND JUICES (U.S. CLS. 45, 46 AND 48).  
ELIZABETH KAJUBI, EXAMINING ATTORNEY

---

SN 85-140,470. FUTURE DONTICS, INC., LOS ANGELES, CA.  
FILED 9-28-2010.

## 800DENTIST

THE MARK CONSISTS OF STANDARD CHARACTERS WITHOUT CLAIM TO ANY PARTICULAR FONT, STYLE, SIZE, OR COLOR.

OWNER OF U.S. REG. NOS. 1,663,616, 3,877,773 AND OTHERS.  
SEC. 2(F).

### CLASS 35—ADVERTISING AND BUSINESS

FOR PROVIDING ONLINE REFERRALS OF MEDICAL AND DENTAL PROFESSIONALS AND REFERRALS IN THE FIELD OF MEDICINE AND DENTISTRY; PROVIDING ONLINE MARKETING, NAMELY, PROMOTING THE SERVICES OF MEDICAL AND DENTAL PROFESSIONALS (U.S. CLS. 100, 101 AND 102).

### CLASS 44—MEDICAL, BEAUTY AND AGRICULTURAL SERVICES

FOR PROVIDING INFORMATION IN THE FIELD OF DENTISTRY VIA AN ELECTRONIC COMMUNICATIONS NETWORK (U.S. CLS. 100 AND 101).  
MARK RADEMACHER, EXAMINING ATTORNEY

## Avatar Micro

THE MARK CONSISTS OF STANDARD CHARACTERS WITHOUT CLAIM TO ANY PARTICULAR FONT, STYLE, SIZE, OR COLOR.

OWNER OF U.S. REG. NOS. 3,583,335 AND 3,704,195.  
NO CLAIM IS MADE TO THE EXCLUSIVE RIGHT TO USE "MICRO", APART FROM THE MARK AS SHOWN.

### CLASS 7—MACHINERY

FOR INDUSTRIAL ROBOTS (U.S. CLS. 13, 19, 21, 23, 31, 34 AND 35).  
FIRST USE 7-16-2008; IN COMMERCE 7-21-2008.

### CLASS 9—ELECTRICAL AND SCIENTIFIC APPARATUS

FOR MANIPULATORS FOR THE REMOTE OPERATION OF ROBOTIC ARMS; ROBOTS FOR PERSONAL OR HOBBY USE; ROBOTS FOR PERSONAL, EDUCATIONAL AND HOBBY USE AND STRUCTURAL PARTS THEREFOR; TACTICAL ROBOTS (U.S. CLS. 21, 23, 26, 31 AND 38).  
FIRST USE 7-16-2008; IN COMMERCE 7-21-2008.

### CLASS 12—VEHICLES

FOR REMOTELY CONTROLLED LAND VEHICLE; ROBOTIC TRANSPORT VEHICLES (U.S. CLS. 19, 21, 23, 31, 35 AND 44).  
FIRST USE 7-16-2008; IN COMMERCE 7-21-2008.

### CLASS 28—TOYS AND SPORTING GOODS

FOR REMOTE CONTROL TOYS, NAMELY, WEAPONIZED SMALL GROUND VEHICLES (U.S. CLS. 22, 23, 38 AND 50).  
FIRST USE 7-16-2008; IN COMMERCE 7-21-2008.  
ZHALEH DELANEY, EXAMINING ATTORNEY

---

SN 85-140,572. PULTRON COMPOSITES LIMITED, GISBORNE, NEW ZEALAND, FILED 9-29-2010.

## MATEEN

THE MARK CONSISTS OF STANDARD CHARACTERS WITHOUT CLAIM TO ANY PARTICULAR FONT, STYLE, SIZE, OR COLOR.

### CLASS 19—NON-METALLIC BUILDING MATERIALS

FOR NON-METAL BUILDING MATERIALS, NAMELY, COMPOSITE REINFORCING BARS AND COMPOSITE DOWELS (U.S. CLS. 1, 12, 33 AND 50).

**CLASS 20—FURNITURE AND ARTICLES NOT OTHERWISE CLASSIFIED**

FOR NON-METAL FASTENERS, NAMELY, BOLTS AND NAILS; NON-METAL BOLTS, NAMELY, ROCK BOLTS AND ANCHOR BOLTS; AND NON-METAL SOIL NAILS (U.S. CLS. 2, 13, 22, 25, 32 AND 50).

PAUL E. FAHRENKOPF, EXAMINING ATTORNEY

---

SN 85-140,650. RUG DOCTOR, INC., PLANO, TX. FILED 9-29-2010.

## Pet Doctor by Rug Doctor

THE MARK CONSISTS OF STANDARD CHARACTERS WITHOUT CLAIM TO ANY PARTICULAR FONT, STYLE, SIZE, OR COLOR.

OWNER OF U.S. REG. NOS. 973,037, 2,536,671 AND 2,624,580.

NO CLAIM IS MADE TO THE EXCLUSIVE RIGHT TO USE "PET" AND "RUG", APART FROM THE MARK AS SHOWN.

**CLASS 3—COSMETICS AND CLEANING PREPARATIONS**

FOR CLEANING PREPARATIONS; DETERGENTS; STAIN REMOVING PREPARATIONS; CLEANING PREPARATIONS HAVING DEODORIZING PROPERTIES; ALL FOR THE MAINTENANCE OF CARPETS, RUGS, FLOORS, UPHOLSTERY, FURNITURE AND OTHER TEXTILES OR FIBROUS FABRICS OR MATERIALS (U.S. CLS. 1, 4, 6, 50, 51 AND 52).

**CLASS 37—CONSTRUCTION AND REPAIR**

FOR CLEANING SERVICES, NAMELY, TO CLEAN, DEODORIZE AND REMOVE ALL FOREIGN MATTER FROM CARPETS, RUGS, FLOORS, UPHOLSTERY, FURNITURE AND OTHER TEXTILES OR FIBROUS FABRICS OR MATERIALS (U.S. CLS. 100, 103 AND 106).

ALEXANDER L. POWERS, EXAMINING ATTORNEY

---

SN 85-140,658. RUG DOCTOR, INC., PLANO, TX. FILED 9-29-2010.

## Pet Doctor

THE MARK CONSISTS OF STANDARD CHARACTERS WITHOUT CLAIM TO ANY PARTICULAR FONT, STYLE, SIZE, OR COLOR.

NO CLAIM IS MADE TO THE EXCLUSIVE RIGHT TO USE "PET", APART FROM THE MARK AS SHOWN.

**CLASS 3—COSMETICS AND CLEANING PREPARATIONS**

FOR CLEANING PREPARATIONS; DETERGENTS; STAIN REMOVING PREPARATIONS; CLEANING PREPARATIONS HAVING DEODORIZING PROPERTIES; ALL FOR THE MAINTENANCE OF CARPETS, RUGS, FLOORS, UPHOLSTERY, FURNITURE AND OTHER TEXTILES OR FIBROUS FABRICS OR MATERIALS (U.S. CLS. 1, 4, 6, 50, 51 AND 52).

**CLASS 37—CONSTRUCTION AND REPAIR**

FOR CLEANING SERVICES, NAMELY, TO CLEAN, DEODORIZE AND REMOVE ALL FOREIGN MATTER FROM CARPETS, RUGS, FLOORS, UPHOLSTERY, FURNITURE AND OTHER TEXTILES OR FIBROUS FABRICS OR MATERIALS (U.S. CLS. 100, 103 AND 106).

ALEXANDER L. POWERS, EXAMINING ATTORNEY

---

SN 85-140,666. CROWN CASTLE INTERNATIONAL CORP., HOUSTON, TX. FILED 9-29-2010.

## WE ARE SOLUTIONS

THE MARK CONSISTS OF STANDARD CHARACTERS WITHOUT CLAIM TO ANY PARTICULAR FONT, STYLE, SIZE, OR COLOR.

**CLASS 36—INSURANCE AND FINANCIAL**

FOR REAL ESTATE ACQUISITION SERVICES FOR TELECOMMUNICATION, TRANSMISSION, AND BROADCASTING FACILITIES; REAL ESTATE MANAGEMENT; REAL ESTATE MANAGEMENT IN THE NATURE OF TELECOMMUNICATION SITE MANAGEMENT; REAL ESTATE DEVELOPMENT SERVICES (U.S. CLS. 100, 101 AND 102).

FIRST USE 4-24-2010; IN COMMERCE 4-24-2010.

**CLASS 37—CONSTRUCTION AND REPAIR**

FOR INSTALLATION AND MAINTENANCE OF TELECOMMUNICATION TRANSMISSION AND BROADCASTING EQUIPMENT, APPARATUS, AND INSTRUMENTS FOR TELECOMMUNICATIONS AND TRANSMISSIONS; CONSULTATION RELATING TO THE INSTALLATION AND MAINTENANCE OF TELECOMMUNICATION TRANSMISSION AND BROADCASTING EQUIPMENT, APPARATUS AND INSTRUMENTS; CONSTRUCTION PLANNING OF TELECOMMUNICATION FACILITIES (U.S. CLS. 100, 103 AND 106).

FIRST USE 4-24-2010; IN COMMERCE 4-24-2010.

**CLASS 38—COMMUNICATION**

FOR RADIO AND TELEVISION BROADCASTING ALL THROUGH A SHARED TELECOMMUNICATIONS INFRASTRUCTURE; TELECOMMUNICATION SERVICES, NAMELY, LOCAL AND LONG DISTANCE TRANSMISSION OF VOICE, DATA, GRAPHICS BY MEANS OF TELEPHONE, TELEGRAPHIC, CABLE, AND SATELLITE TRANSMISSIONS; PROVIDING INFORMATION TRANSMISSION NETWORK SERVICES FOR WIRELESS COMMUNICATIONS (U.S. CLS. 100, 101 AND 104).

FIRST USE 4-24-2010; IN COMMERCE 4-24-2010.  
WILLIAM ROSSMAN, EXAMINING ATTORNEY

SN 85-141,198. RED HAT, INC., RALEIGH, NC. FILED 9-29-2010.

# RHCSA

THE MARK CONSISTS OF STANDARD CHARACTERS WITHOUT CLAIM TO ANY PARTICULAR FONT, STYLE, SIZE, OR COLOR.

OWNER OF U.S. REG. NO. 3,269,105.

## CLASS 9—ELECTRICAL AND SCIENTIFIC APPARATUS

FOR DOWNLOADABLE ELECTRONIC PUBLICATIONS IN THE NATURE OF INSTRUCTIONAL BOOKS, INSTRUCTIONAL MANUALS, TEACHER'S GUIDES, TEACHING MATERIALS, TEST BOOKLETS, AND CERTIFICATES IN THE FIELD OF COMPUTER NETWORKING AND MAINTENANCE, COMPUTER NETWORK CONFIGURATION, COMPUTER SOFTWARE INSTALLATION, MAINTENANCE, UPDATING, CONFIGURATION AND PROGRAMMING, TECHNICAL SUPPORT SERVICES FOR COMPUTER SOFTWARE AND COMPUTER NETWORKING, AND COMPUTER SOFTWARE AND COMPUTER NETWORKING CONSULTATION FOR OTHERS (U.S. CLS. 21, 23, 26, 36 AND 38).

## CLASS 16—PAPER GOODS AND PRINTED MATTER

FOR PRINTED MATERIALS, NAMELY, INSTRUCTIONAL BOOKS, INSTRUCTIONAL MANUALS, TEACHER'S GUIDES, TEACHING MATERIALS, TEST BOOKLETS, AND CERTIFICATES, ALL ON THE SUBJECTS OF COMPUTER NETWORKING AND MAINTENANCE, COMPUTER NETWORK CONFIGURATION, COMPUTER SOFTWARE INSTALLATION, MAINTENANCE, UPDATING, CONFIGURATION AND PROGRAMMING, TECHNICAL SUPPORT SERVICES FOR COMPUTER SOFTWARE AND COMPUTER NETWORKING, AND COMPUTER SOFTWARE AND COMPUTER NETWORKING CONSULTATION FOR OTHERS (U.S. CLS. 2, 5, 22, 23, 29, 37, 38 AND 50).

## CLASS 35—ADVERTISING AND BUSINESS

FOR TESTING TO DETERMINE PROFESSIONAL COMPETENCY (U.S. CLS. 100, 101 AND 102).

## CLASS 41—EDUCATION AND ENTERTAINMENT

FOR EDUCATION SERVICES, NAMELY, PROVIDING LIVE AND ON-LINE SEMINARS, COURSES AND WORKSHOPS IN THE FIELD OF THE USE, MAINTENANCE, UPDATING, CONFIGURATION, INSTALLATION, SUPPORT AND PROGRAMMING OF COMPUTER SOFTWARE AND COMPUTER NETWORKING; PROVIDING ONLINE PUBLICATIONS AND INFORMATION, NAMELY, INSTRUCTIONAL BOOKS, INSTRUCTION MANUALS, INSTRUCTOR'S GUIDES, TEACHING MATERIALS AND TEST BOOKLETS, ALL IN THE FIELD OF THE USE, MAINTENANCE, UPDATING, CONFIGURATION, INSTALLATION, SUPPORT AND PROGRAMMING OF COMPUTER SOFTWARE AND COMPUTER NETWORKING (U.S. CLS. 100, 101 AND 107).

## CLASS 42—SCIENTIFIC AND COMPUTER SERVICES

FOR TECHNICAL CONSULTATION IN THE FIELD OF COMPUTER NETWORKING AND MAINTENANCE; COMPUTER NETWORK CONFIGURATION; COMPUTER SOFTWARE INSTALLATION, MAINTENANCE, UPDATING, CONFIGURATION AND PROGRAMMING; TECHNICAL SUPPORT SERVICES, NAMELY, TROUBLESHOOTING OF COMPUTER SOFTWARE PROBLEMS; AND COMPUTER SOFTWARE AND COMPUTER NETWORKING CONSULTATION FOR OTHERS (U.S. CLS. 100 AND 101).

WON TEAK OH, EXAMINING ATTORNEY

SN 85-142,083. NAVID LAVI, BEVERLY HILLS, CA. FILED 9-30-2010.

# COFFEETAMIN

THE MARK CONSISTS OF STANDARD CHARACTERS WITHOUT CLAIM TO ANY PARTICULAR FONT, STYLE, SIZE, OR COLOR.

## CLASS 5—PHARMACEUTICALS

FOR COFFEE-BASED VITAMIN FORTIFIED BEVERAGES (U.S. CLS. 6, 18, 44, 46, 51 AND 52).

## CLASS 30—STAPLE FOODS

FOR COFFEE, BEVERAGES MADE OF COFFEE BASE (U.S. CL. 46).  
MELISSA VALLILLO, EXAMINING ATTORNEY

SN 85-142,333. MARTINO, KRISTOPHER M, HENDERSON, NV. FILED 9-30-2010.

# Watchtower Mortgage Company

THE MARK CONSISTS OF STANDARD CHARACTERS WITHOUT CLAIM TO ANY PARTICULAR FONT, STYLE, SIZE, OR COLOR.

NO CLAIM IS MADE TO THE EXCLUSIVE RIGHT TO USE "MORTGAGE COMPANY", APART FROM THE MARK AS SHOWN.

## CLASS 35—ADVERTISING AND BUSINESS

FOR MATCHING BORROWERS WITH POTENTIAL LENDERS IN THE FIELD OF CONSUMER AND MORTGAGE LENDING; MATCHING BORROWERS WITH POTENTIAL LENDERS IN THE FIELD OF MORTGAGE LENDING; PROVIDING STATISTICAL INFORMATION AND INDEXES OF MORTGAGES, INTERESTS, AND PRICES FOR OTHERS (U.S. CLS. 100, 101 AND 102).

FIRST USE 8-30-2010; IN COMMERCE 8-30-2010.

**CLASS 36—INSURANCE AND FINANCIAL**

FOR FINANCIAL SERVICES, NAMELY, MORTGAGE PLANNING; FINANCIAL SERVICES, NAMELY, MORTGAGE REFINANCING; MORTGAGE BANKING; MORTGAGE BANKING SERVICES, NAMELY, ORIGATION, ACQUISITION, SERVICING, SECURITIZATION AND BROKERAGE OF MORTGAGE LOANS; MORTGAGE BROKERAGE; MORTGAGE COMPLIANCE CONSULTING SERVICES CONCERNING FINANCIAL REQUIREMENTS FOR MORTGAGES FOR MORTGAGE LENDERS AND SERVICERS AND MORTGAGE BROKERS; MORTGAGE LENDING; MORTGAGE PROCUREMENT FOR OTHERS; MORTGAGE SERVICES, NAMELY, BUYER PRE-QUALIFICATION OF MORTGAGES FOR MORTGAGE BROKERS AND BANKS (U.S. CLS. 100, 101 AND 102).

FIRST USE 8-30-2010; IN COMMERCE 8-30-2010.  
WILLIAM P. SHANAHAN, EXAMINING ATTORNEY

SN 85-143,151. ASSOCIATED EQUIPMENT CORPORATION, ST. LOUIS, MO. FILED 10-1-2010.

# WELDSENSE

THE MARK CONSISTS OF STANDARD CHARACTERS WITHOUT CLAIM TO ANY PARTICULAR FONT, STYLE, SIZE, OR COLOR.

**CLASS 7—MACHINERY**

FOR PRESSURE SWITCHES AND SENSORS AS PARTS OF MACHINES, NAMELY, SWITCHES AND SENSORS USED TO AUTOMATICALLY TURN A FUME EXTRACTOR ON AND OFF WHEN IT DETECTS A WELDING ARC (U.S. CLS. 13, 19, 21, 23, 31, 34 AND 35).

**CLASS 11—ENVIRONMENTAL CONTROL APPARATUS**

FOR AMBIENT AIR CLEANERS AND FILTERS THEREFOR; INDUSTRIAL FANS AND BLOWERS USED FOR FUME EXTRACTION IN WELDING AND INDUSTRIAL SHOP CLEANING; FUME EXHAUSTER AND BLOWERS USED FOR INDUSTRIAL CLEANING; FUME EXTRACTORS AND FILTERS THEREFOR FOR WELDING AND INDUSTRIAL USE; DOWNDRAFT TABLES AND FILTERS THEREFOR FOR WELDING AND INDUSTRIAL USE; EXTRACTION ARMS USED WITH WELDING FUME EXTRACTORS FOR WELDING AND INDUSTRIAL SHOP CLEANING (U.S. CLS. 13, 21, 23, 31 AND 34).

LINDA ORNDORFF, EXAMINING ATTORNEY

SN 85-143,224. VPCININNATI, LLC, CINCINNATI, OH. FILED 10-1-2010.

# Hahana Beach

THE MARK CONSISTS OF STANDARD CHARACTERS WITHOUT CLAIM TO ANY PARTICULAR FONT, STYLE, SIZE, OR COLOR.

THE ENGLISH TRANSLATION OF "HAHANA" IN THE MARK IS HOT OR SULTRY.

**CLASS 41—EDUCATION AND ENTERTAINMENT**

FOR ARRANGING, ORGANIZING, CONDUCTING, AND HOSTING ENTERTAINMENT EVENTS, NAMELY, AMATEUR AND PROFESSIONAL VOLLEYBALL TOURNAMENTS, SKATE AND BMX EVENTS AND STAND UP PADDLE EXHIBITIONS; ARRANGING, ORGANIZING, CONDUCTING AND HOSTING AMATEUR AND PROFESSIONAL VOLLEYBALL TOURNAMENTS, SKATE AND BMX EVENTS, STAND UP PADDLE EXHIBITIONS AND COMPETITIVE LEAGUES; ENTERTAINMENT SERVICES, NAMELY, PERSONAL APPEARANCES BY PROFESSIONAL ATHLETES, MODELS AND CELEBRITIES; EDUCATIONAL AND ATHLETIC TRAINING SERVICES IN THE FIELD OF PHYSICAL FITNESS, SPORTS AND VOLLEYBALL; ARRANGING, ORGANIZING, CONDUCTING AND HOSTING CLASSES, SEMINARS, CONFERENCES AND WORKSHOPS IN THE FIELDS OF PHYSICAL FITNESS, SPORTS AND VOLLEYBALL; PROVIDING AN ONLINE NEWSLETTER IN THE FIELD OF VOLLEYBALL; PROVIDING A WEBSITE FEATURING INFORMATION ABOUT VOLLEYBALL (U.S. CLS. 100, 101 AND 107).

FIRST USE 7-4-2010; IN COMMERCE 8-4-2010.

**CLASS 43—HOTEL AND RESTAURANT SERVICES**

FOR BAR AND RESTAURANT SERVICES (U.S. CLS. 100 AND 101).

FIRST USE 8-4-2010; IN COMMERCE 9-4-2010.  
JEFF DEFORD, EXAMINING ATTORNEY

SN 85-143,302. ALAMANDA POLYMERS, INC., HUNTSVILLE, AL. FILED 10-1-2010.

# ALAMANDA POLYMERS

THE MARK CONSISTS OF STANDARD CHARACTERS WITHOUT CLAIM TO ANY PARTICULAR FONT, STYLE, SIZE, OR COLOR.

NO CLAIM IS MADE TO THE EXCLUSIVE RIGHT TO USE "POLYMERS", APART FROM THE MARK AS SHOWN.

**CLASS 1—CHEMICALS**

FOR POLYAMINO ACIDS FOR LABORATORY AND RESEARCH USE RELATING TO ENCAPSULATION, GENE THERAPY, DRUG DELIVERY, CELL ADHESION, AND SURFACE COATING (U.S. CLS. 1, 5, 6, 10, 26 AND 46).

FIRST USE 11-15-2007; IN COMMERCE 1-23-2008.

**CLASS 40—MATERIAL TREATMENT**

FOR POLYAMINO ACID SYNTHESIS SERVICES, NAMELY, PROVIDING CUSTOMIZED POLYAMINO ACIDS FOR LABORATORY AND RESEARCH USE RELATING TO ENCAPSULATION, GENE THERAPY, DRUG DELIVERY, CELL ADHESION, AND SURFACE COATING; PROVIDING CONSULTING SERVICES AND ADVICE REGARDING POLYAMINO ACID SYNTHESIS FOR LABORATORY AND RESEARCH USE RELATING TO ENCAPSULATION, GENE THERAPY, DRUG DELIVERY, CELL ADHESION, AND SURFACE COATING (U.S. CLS. 100, 103 AND 106).

FIRST USE 11-15-2007; IN COMMERCE 1-23-2008.  
JASON LOTT, EXAMINING ATTORNEY

SN 85-143,497. STERLING PUBLISHING CO., INC., NEW YORK, NY. FILED 10-1-2010.

# SPLINTER

THE MARK CONSISTS OF THE TERM "SPLINTER" WITH THE IMAGE OF A SPLINTER RUNNING THROUGH THE LETTERS.

## CLASS 9—ELECTRICAL AND SCIENTIFIC APPARATUS

FOR ELECTRONIC DOWNLOADABLE PUBLICATIONS, NAMELY, BOOKS AND PAMPHLETS FEATURING WORKS OF FICTION, BIOGRAPHICAL STORIES, AND POETRY FOR USE PRIMARILY BY TEENS AND YOUNG ADULTS (U.S. CLS. 21, 23, 26, 36 AND 38).

## CLASS 16—PAPER GOODS AND PRINTED MATTER

FOR PRINTED MATTER, NAMELY, BOOKS AND PAMPHLETS FEATURING WORKS OF FICTION, BIOGRAPHICAL STORIES, AND POETRY FOR USE PRIMARILY BY TEENS AND YOUNG ADULTS (U.S. CLS. 2, 5, 22, 23, 29, 37, 38 AND 50).

## CLASS 41—EDUCATION AND ENTERTAINMENT

FOR BOOK PUBLISHING SERVICES; ONLINE ELECTRONIC PUBLISHING OF BOOKS (U.S. CLS. 100, 101 AND 107).

DAVID C. REIHNER, EXAMINING ATTORNEY

SN 85-143,518. ZAG MUSIC GROUP, INC., NEW YORK, NY. FILED 10-1-2010.

# PLAYGROUND SESSIONS

THE MARK CONSISTS OF STANDARD CHARACTERS WITHOUT CLAIM TO ANY PARTICULAR FONT, STYLE, SIZE, OR COLOR.

## CLASS 9—ELECTRICAL AND SCIENTIFIC APPARATUS

FOR DOWNLOADABLE EDUCATIONAL COMPUTER SOFTWARE IN THE FIELD OF MUSIC EDUCATION AND MUSICAL INSTRUMENTS (U.S. CLS. 21, 23, 26, 36 AND 38).

## CLASS 16—PAPER GOODS AND PRINTED MATTER

FOR EDUCATIONAL BOOKS IN THE FIELD OF MUSIC AND MUSICAL INSTRUMENTS (U.S. CLS. 2, 5, 22, 23, 29, 37, 38 AND 50).

## CLASS 42—SCIENTIFIC AND COMPUTER SERVICES

FOR NON-DOWNLOADABLE EDUCATIONAL COMPUTER SOFTWARE IN THE FIELD OF MUSIC EDUCATION AND MUSICAL INSTRUMENTS (U.S. CLS. 100 AND 101).

CURTIS FRENCH, EXAMINING ATTORNEY

SN 85-144,303. ACUITY MARKETING, INC., LEAGUE CITY, TX. FILED 10-4-2010.



NO CLAIM IS MADE TO THE EXCLUSIVE RIGHT TO USE "CAR" AND "SHOW", APART FROM THE MARK AS SHOWN.

THE MARK CONSISTS OF THE WORDING "CAR PRO" WITHIN A RECTANGULAR SHAPED CARRIER CENTERED ON A CHECKERED RACING FLAG AND WITH THE WORDING "THE" ABOVE AND THE WORD "SHOW" BELOW THE FLAG DESIGN WITH A SOLID OVERALL RECTANGLE DESIGN IN THE BACKGROUND.

## CLASS 16—PAPER GOODS AND PRINTED MATTER

FOR PRINTED MATTER, NAMELY, CALENDARS, BUMPER STICKERS, INFORMATIONAL BOOKS AND PAMPHLETS, AND PRINTED NEWSLETTERS FEATURING GENERAL INTEREST NEWS AND COMMENTARY IN THE FIELDS OF AUTOMOBILE CONSUMER EDUCATION, AUTOMOBILE SHOPPING, AUTOMOBILE BUYING AND THE AUTOMOTIVE INDUSTRY (U.S. CLS. 2, 5, 22, 23, 29, 37, 38 AND 50).

FIRST USE 6-30-2010; IN COMMERCE 7-3-2010.

## CLASS 25—CLOTHING

FOR CLOTHING, NAMELY, SHIRTS, T-SHIRTS, SWEAT SHIRTS, HOODED SWEATSHIRTS, CAPS, AND HATS (U.S. CLS. 22 AND 39).

FIRST USE 6-30-2010; IN COMMERCE 7-3-2010.

## CLASS 35—ADVERTISING AND BUSINESS

FOR ON-LINE RETAIL STORE SERVICES FEATURING PRE-RECORDED CDS AND DVDS, DOWNLOADABLE AUDIO FILES, VIDEO FILES, RING TONES, GRAPHICS, MUSIC, AND ELECTRONIC GAMES, CALENDARS, BUMPER STICKERS, INFORMATIONAL BOOKS, SHIRTS, T-SHIRTS, SWEAT SHIRTS, HOODED SWEATSHIRTS, CAPS, AND HATS; PROVIDING ON-LINE ADVERTISING FOR OTHERS; AND PROVIDING TELEVISION AND RADIO ADVERTISING FOR OTHERS (U.S. CLS. 100, 101 AND 102).

FIRST USE 6-30-2010; IN COMMERCE 7-3-2010.

## CLASS 38—COMMUNICATION

FOR INTERNET RADIO BROADCASTING SERVICES; RADIO BROADCASTING; SATELLITE RADIO BROADCASTING; TELEVISION BROADCASTING SERVICES; BROADCASTING OF RADIO AND TELEVISION PROGRAMS; AND PROVIDING ELECTRONIC BULLETIN BOARDS FOR TRANSMISSION OF MESSAGES AMONG USERS IN THE FIELD OF GENERAL INTEREST (U.S. CLS. 100, 101 AND 104).

FIRST USE 6-30-2010; IN COMMERCE 7-3-2010.

**CLASS 41—EDUCATION AND ENTERTAINMENT**

FOR EDUCATIONAL SERVICES, NAMELY, THE PRESENTATION OF SEMINARS, LECTURES, WORKSHOPS AND PANEL DISCUSSIONS IN THE FIELDS OF AUTOMOBILE CONSUMER EDUCATION, AUTOMOBILE SHOPPING, AUTOMOBILE BUYING AND THE AUTOMOTIVE INDUSTRY, AND DISTRIBUTING COURSE MATERIALS IN CONNECTION THEREWITH; ENTERTAINMENT SERVICES, NAMELY, ONGOING TELEVISION AND RADIO TALK PROGRAMS FEATURING GENERAL INTEREST NEWS AND COMMENTARY IN THE FIELDS OF AUTOMOBILE CONSUMER EDUCATION, AUTOMOBILE SHOPPING, AUTOMOBILE BUYING AND THE AUTOMOTIVE INDUSTRY; ENTERTAINMENT SERVICES, NAMELY, PERSONAL APPEARANCES BY A RADIO PERSONALITY; AND ENTERTAINMENT SERVICES, NAMELY, PROVIDING NON-DOWNLOADABLE PRE-RECORDED MUSIC, GAMES AND VIDEOS VIA THE INTERNET, ELECTRONIC STREAMING, MOBILE PHONES AND/OR TELEVISION; PROVIDING OF ONLINE NON-DOWNLOADABLE ELECTRONIC PUBLICATIONS IN THE NATURE OF ELECTRONIC BOOKS AND VIDEOS FEATURING GENERAL INTEREST NEWS AND COMMENTARY IN THE FIELDS OF AUTOMOBILE CONSUMER EDUCATION, AUTOMOBILE SHOPPING, AUTOMOBILE BUYING AND THE AUTOMOTIVE INDUSTRY (U.S. CLS. 100, 101 AND 107).

FIRST USE 6-30-2010; IN COMMERCE 7-3-2010.  
BARBARA BROWN, EXAMINING ATTORNEY

**CLASS 35—ADVERTISING AND BUSINESS**

FOR ON-LINE RETAIL STORE SERVICES FEATURING PRE-RECORDED CDS AND DVDS, DOWNLOADABLE AUDIO FILES, VIDEO FILES, RING TONES, GRAPHICS, MUSIC, AND ELECTRONIC GAMES, CALENDARS, BUMPER STICKERS, INFORMATIONAL BOOKS, SHIRTS, T-SHIRTS, SWEAT SHIRTS, HOODED SWEATSHIRTS, CAPS, AND HATS; PROVIDING ON-LINE ADVERTISING FOR OTHERS; AND PROVIDING TELEVISION AND RADIO ADVERTISING FOR OTHERS (U.S. CLS. 100, 101 AND 102).

FIRST USE 6-30-2010; IN COMMERCE 7-3-2010.

**CLASS 38—COMMUNICATION**

FOR INTERNET RADIO BROADCASTING SERVICES; RADIO BROADCASTING; SATELLITE RADIO BROADCASTING; TELEVISION BROADCASTING SERVICES; BROADCASTING OF RADIO AND TELEVISION PROGRAMS; AND PROVIDING ELECTRONIC BULLETIN BOARDS FOR TRANSMISSION OF MESSAGES AMONG USERS IN THE FIELD OF GENERAL INTEREST (U.S. CLS. 100, 101 AND 104).

FIRST USE 6-30-2010; IN COMMERCE 7-3-2010.  
BARBARA BROWN, EXAMINING ATTORNEY

SN 85-144,412. MULLIN, GERARD, BALTIMORE, MD.  
FILED 10-4-2010.

SN 85-144,307. ACUITY MARKETING, INC., LEAGUE CITY, TX. FILED 10-4-2010.

**INSIDE TRACT****THE CAR PRO SHOW**

THE MARK CONSISTS OF STANDARD CHARACTERS WITHOUT CLAIM TO ANY PARTICULAR FONT, STYLE, SIZE, OR COLOR.

NO CLAIM IS MADE TO THE EXCLUSIVE RIGHT TO USE "CAR" AND "SHOW", APART FROM THE MARK AS SHOWN.

**CLASS 16—PAPER GOODS AND PRINTED MATTER**

FOR PRINTED MATTER, NAMELY, CALENDARS, BUMPER STICKERS, INFORMATIONAL BOOKS AND PAMPHLETS, AND PRINTED NEWSLETTERS FEATURING GENERAL INTEREST NEWS AND COMMENTARY IN THE FIELDS OF AUTOMOBILE CONSUMER EDUCATION, AUTOMOBILE SHOPPING, AUTOMOBILE BUYING AND THE AUTOMOTIVE INDUSTRY (U.S. CLS. 2, 5, 22, 23, 29, 37, 38 AND 50).

FIRST USE 6-30-2010; IN COMMERCE 7-3-2010.

**CLASS 25—CLOTHING**

FOR CLOTHING, NAMELY, SHIRTS, T-SHIRTS, SWEAT SHIRTS, HOODED SWEATSHIRTS, CAPS, AND HATS (U.S. CLS. 22 AND 39).

FIRST USE 6-30-2010; IN COMMERCE 7-3-2010.

THE MARK CONSISTS OF STANDARD CHARACTERS WITHOUT CLAIM TO ANY PARTICULAR FONT, STYLE, SIZE, OR COLOR.

**CLASS 5—PHARMACEUTICALS**

FOR DIETARY AND NUTRITIONAL SUPPLEMENTS; NATURAL HERBAL SUPPLEMENTS; VITAMIN AND MINERAL SUPPLEMENTS (U.S. CLS. 6, 18, 44, 46, 51 AND 52).

**CLASS 16—PAPER GOODS AND PRINTED MATTER**

FOR COOKBOOKS; BROCHURES AND LEAFLETS FEATURING COOKING INSTRUCTIONS, MENUS, SHOPPING LISTS, RECIPES AND GENERAL INFORMATION REGARDING HEALTHY EATING (U.S. CLS. 2, 5, 22, 23, 29, 37, 38 AND 50).

**CLASS 41—EDUCATION AND ENTERTAINMENT**

FOR PROVIDING ONLINE NEWSLETTERS AND COMMENTARY IN THE FIELD OF DIET AND HEALTH, HERBAL, VITAMIN AND MINERAL SUPPLEMENTS AND PREPARATIONS, AND HEALTHY EATING; EDUCATIONAL SERVICES, NAMELY, DEVELOPING AND CONDUCTING WORKSHOPS, PRESENTATIONS AND PERSONAL TRAINING IN THE FIELDS OF DIET, GASTROINTESTINAL HEALTH AND WELLNESS (U.S. CLS. 100, 101 AND 107).

**CLASS 43—HOTEL AND RESTAURANT SERVICES**

FOR FOOD PREPARATION SERVICES FEATURING FRESH, PROPERLY PROPORTIONED, HEALTHY MEALS DESIGNED TO PROMOTE GASTROINTESTINAL HEALTH AND GENERAL WELLNESS; PROVIDING INFORMATION IN THE FIELD OF RECIPES AND COOKING INFORMATION, NAMELY, SHOPPING LISTS AND MENUS IN THE FIELDS OF HEALTH AND FOOD NUTRITION VIA GLOBAL COMPUTER NETWORKS, DATA NETWORKS AND MOBILE NETWORKS (U.S. CLS. 100 AND 101).

BENJAMIN OKEKE, EXAMINING ATTORNEY

SN 85-144,715. CHAMPION LABORATORIES, INC., ALBION, IL. FILED 10-4-2010.

**EUROFILTER**

THE MARK CONSISTS OF STANDARD CHARACTERS WITHOUT CLAIM TO ANY PARTICULAR FONT, STYLE, SIZE, OR COLOR.

**CLASS 7—MACHINERY**

FOR HEAVY DUTY AIR FILTERS FOR GAS TURBINES FOR LAND VEHICLES (U.S. CLS. 13, 19, 21, 23, 31, 34 AND 35).

**CLASS 11—ENVIRONMENTAL CONTROL APPARATUS**

FOR HEAVY DUTY AIR FILTERS FOR INDUSTRIAL INSTALLATIONS FOR USE IN DUST COLLECTION (U.S. CLS. 13, 21, 23, 31 AND 34).

JAMES LOVELACE, EXAMINING ATTORNEY

SN 85-144,629. POWERPACT HOLDINGS LLC, MIDLOTHIAN, VA. FILED 10-4-2010.



NO CLAIM IS MADE TO THE EXCLUSIVE RIGHT TO USE "HOLDINGS", APART FROM THE MARK AS SHOWN. THE MARK CONSISTS OF THE WORDS "DIGINARY HOLDINGS" ON A BACKGROUND OF MULTIPLE SQUARES FORMING A RECTANGLE WITH A BRIGHT LIGHT SHINING ON THE SQUARE BETWEEN THE TWO WORDS.

**CLASS 35—ADVERTISING AND BUSINESS**

FOR ADVERTISING SERVICES, PROMOTIONAL SERVICES AND MARKETING SERVICES, NAMELY, PROMOTING AND MARKETING THE GOODS AND SERVICES OF OTHERS THROUGH PUBLIC COMMUNICATION CHANNELS, CONSUMER PROMOTIONS, CAUSE MARKETING; DIRECT MAIL MARKETING PROMOTIONS; PUBLIC RELATIONS SERVICES; BRAND NAME DEVELOPMENT AND CORPORATE IDENTITY SERVICES FOR OTHERS; DESIGN STRATEGIC SPONSORSHIP SEARCH SERVICES; LOYALTY MARKETING SERVICES THROUGH CUSTOMER AND EMPLOYEE APPRECIATION AND REWARDS PROGRAMS; SOCIAL MEDIA STRATEGY AND MARKETING CONSULTANCY FOCUSING ON HELPING CLIENTS CREATE AND EXTEND THEIR PRODUCT AND BRAND STRATEGIES BY BUILDING VIRALLY ENGAGING MARKETING SOLUTIONS; INTERACTIVE MARKETING (U.S. CLS. 100, 101 AND 102).

**CLASS 41—EDUCATION AND ENTERTAINMENT**

FOR VIDEO PRODUCTION; DISTRIBUTION OF VIDEOS IN THE FIELD PUBLIC RELATIONS; SEARCH OPTIMIZED VIDEO PRODUCTION; TELEVISION PROGRAM SYNDICATION; VIDEO EDITING OPTIMIZATION (U.S. CLS. 100, 101 AND 107).

**CLASS 42—SCIENTIFIC AND COMPUTER SERVICES**

FOR SOFTWARE DEVELOPMENT RELATED TO ONLINE VIDEO PRODUCTION, DISTRIBUTION, EXHIBITION, DISPLAY, AND OPTIMIZATION; COMPUTER SERVICES, NAMELY, SEARCH ENGINE OPTIMIZATION; WEB SITE DEVELOPMENT FOR OTHERS (U.S. CLS. 100 AND 101).

KAPIL BHANOT, EXAMINING ATTORNEY

SN 85-144,758. MY MOBILE GENIUS, LLC, A LIMITED LIABILITY CORPORATION OF WYOMING, DBA MY MOBILE GENIUS, LLC, LONE TREE, CO. FILED 10-4-2010.



NO CLAIM IS MADE TO THE EXCLUSIVE RIGHT TO USE "MOBILE", APART FROM THE MARK AS SHOWN.

THE COLOR(S) RED AND BLACK IS/ARE CLAIMED AS A FEATURE OF THE MARK.

THE MARK CONSISTS OF STYLIZED WORDS "MY MOBILE" STACKED ABOVE THE STYLIZED WORD "GENIUS". "MY" AND "GENIUS" IS IN BLACK, AND "MOBILE" IS IN RED. ALL OF THIS ABOVE A RED LINE. BELOW THE LINE ARE THE STYLIZED WORDS "EMPOWERING MOBILITY" IN BLACK.

**CLASS 38—COMMUNICATION**

FOR INTERACTIVE DELIVERY OF VIDEO OVER DIGITAL NETWORKS; STREAMING OF VIDEO MATERIAL ON THE INTERNET; STREAMING OF DIGITAL VIDEO TRAINING MATERIAL ON THE INTERNET; TELECOMMUNICATION SERVICES, NAMELY, LOCAL AND LONG DISTANCE TRANSMISSION OF VOICE, DATA, GRAPHICS AND VIDEO BY MEANS OF BROADBAND OPTICAL OR WIRELESS NETWORKS; TELECOMMUNICATION SERVICES, NAMELY, LOCAL AND LONG DISTANCE TRANSMISSION OF VOICE, DATA, GRAPHICS AND VIDEO BY MEANS OF BROADBAND, COPPER AND OPTICAL OR WIRELESS NETWORKS; VIDEO ON DEMAND TRANSMISSIONS; VIDEO-ON-DEMAND TRANSMISSION SERVICES VIA THE INTERNET (U.S. CLS. 100, 101 AND 104).

**CLASS 41—EDUCATION AND ENTERTAINMENT**

FOR COMPUTER EDUCATION TRAINING; COMPUTER EDUCATION TRAINING SERVICES; DIGITAL VIDEO, AUDIO, AND MULTIMEDIA PUBLISHING SERVICES; PRODUCTION OF VISUAL EFFECTS FOR VIDEOS, DVDS, TELEVISION AND FOR INTERNET WEB SITES; PROVIDING ON-LINE TRAINING STREAMING VIDEO IN THE FIELD OF SMARTPHONE SETUP AND USE, CELLULAR PHONE SETUP AND USE; TRAINING IN THE FIELD OF DESIGN, ADVERTISING AND COMMUNICATION TECHNOLOGIES; TRAINING IN THE USE AND OPERATION OF SMARTPHONES, CELLULAR PHONES; TRAINING SERVICES IN THE FIELD OF SMARTPHONES, CELLULAR PHONES; VIDEO PRODUCTION SERVICES (U.S. CLS. 100, 101 AND 107).

GRETTA YAO, EXAMINING ATTORNEY

SN 85-144,974. UNITED STATES DEPARTMENT OF HOMELAND SECURITY, WASHINGTON, DC. FILED 10-5-2010.



THE COLOR(S) RED, WHITE, BLUE AND BLACK IS/ARE CLAIMED AS A FEATURE OF THE MARK.

THE MARK CONSISTS OF THE STYLIZED WORDING "E-VERIFY", WITH THE "E" APPEARING IN RED ON A WHITE BACKGROUND, A HYPHEN IN BLACK, AND THE STYLIZED WORD "VERIFY" APPEARING IN BLUE. THERE IS ALSO A STYLIZED UNITED STATES FLAG IN RED, WHITE AND BLUE, WITH WAVY, HORIZONTAL LINES COMPRISING THE FIRST LETTER "E" IN THE MARK.

**CLASS 35—ADVERTISING AND BUSINESS**

FOR EMPLOYMENT VERIFICATION (U.S. CLS. 100, 101 AND 102).  
FIRST USE 7-31-2007; IN COMMERCE 7-31-2007.

**CLASS 45—PERSONAL AND LEGAL SERVICES**

FOR IDENTIFICATION VERIFICATION SERVICES, NAMELY, PROVIDING AUTHENTICATION OF PERSONAL IDENTIFICATION INFORMATION VIA SECURE STORAGE AND TRANSMITTING SUCH INFORMATION VIA THE INTERNET (U.S. CLS. 100 AND 101).

FIRST USE 7-31-2007; IN COMMERCE 7-31-2007.  
JULIE GUTTADAURO, EXAMINING ATTORNEY

SN 85-145,055. WALKER, CHUCK, HALEIWA, HI. FILED 10-5-2010.



NO CLAIM IS MADE TO THE EXCLUSIVE RIGHT TO USE "NORTH SHORE LEATHER" AND "HAWAII", APART FROM THE MARK AS SHOWN.

THE MARK CONSISTS OF A SKULL AND CROSS BONES WITH A PATCH OVER THE RIGHT EYE WITH THE STYLIZED TEXT "NORTH SHORE LEATHER" ON TOP AND THE STYLIZED TEXT "HAWAII" ON THE BOTTOM. THERE IS A SCROLL WORK ON EITHER SIDE OF THE WORD "HAWAII" WITH A CROSS IN EACH OF THE FOUR CORNERS.

**CLASS 18—LEATHER GOODS**

FOR LEATHER WALLETS (U.S. CLS. 1, 2, 3, 22 AND 41).  
FIRST USE 6-0-2010; IN COMMERCE 6-0-2010.

**CLASS 25—CLOTHING**

FOR LEATHER CLOTHING, NAMELY, BELTS, HATS, JACKETS, PANTS, SHIRTS AND VESTS (U.S. CLS. 22 AND 39).  
FIRST USE 6-0-2010; IN COMMERCE 6-0-2010.  
MARTHA FROMM, EXAMINING ATTORNEY

SN 85-145,097. THOMAS PUBLISHING COMPANY, NEW YORK, NY. FILED 10-5-2010.

**INDUSTRY MARKET BAROMETER**

THE MARK CONSISTS OF STANDARD CHARACTERS WITHOUT CLAIM TO ANY PARTICULAR FONT, STYLE, SIZE, OR COLOR.

OWNER OF U.S. REG. NO. 3,177,614.  
NO CLAIM IS MADE TO THE EXCLUSIVE RIGHT TO USE "INDUSTRY MARKET", APART FROM THE MARK AS SHOWN.

**CLASS 16—PAPER GOODS AND PRINTED MATTER**

FOR PRINTED PUBLICATIONS, NAMELY, SURVEY RESULT REPORTS IN THE FIELD OF BUSINESS AND MARKETING (U.S. CLS. 2, 5, 22, 23, 29, 37, 38 AND 50).  
FIRST USE 1-0-2009; IN COMMERCE 1-0-2009.

**CLASS 35—ADVERTISING AND BUSINESS**

FOR CONDUCTING BUSINESS AND MARKET RESEARCH SURVEYS (U.S. CLS. 100, 101 AND 102).  
FIRST USE 1-0-2009; IN COMMERCE 1-0-2009.  
JAMES LOVELACE, EXAMINING ATTORNEY



SN 85-145,325. CALIFORNIA SHEET METAL WORKS, INC.,  
EL CAJON, CA. FILED 10-5-2010.



NO CLAIM IS MADE TO THE EXCLUSIVE RIGHT TO USE "SHEET METAL", APART FROM THE MARK AS SHOWN.

THE MARK CONSISTS OF A SQUARE BLOCK FOLLOWED BY THE WORD "CALIFORNIA", ABOVE ANOTHER SQUARE BLOCK FOLLOWED BY THE WORD "SHEET", ABOVE ANOTHER SQUARE BLOCK FOLLOWED BY THE WORD "METAL", AND ALL ELEMENTS ARE CONTAINED IN A DARK RECTANGLE.

SEC. 2(F).

#### CLASS 37—CONSTRUCTION AND REPAIR

FOR INSTALLATION OF LOUVERS, FLASHINGS, GUTTERS, DOWNSPOUT, COLUMN COVERS, ROOFING, WALL PANELS, HEATING, VENTILATION AND AIR CONDITIONING DUCTS AND OTHER CUSTOM ARCHITECTURAL METAL ITEMS AND PRODUCTS FOR COMMERCIAL, INDUSTRIAL, AND OFFICE BUILDINGS (U.S. CLS. 100, 103 AND 106).

FIRST USE 1-1-1913; IN COMMERCE 1-1-2003.

#### CLASS 40—MATERIAL TREATMENT

FOR CUSTOM FABRICATION AND PRODUCTION OF LOUVERS, FLASHINGS, GUTTERS, DOWNSPOUTS, COLUMN COVERS, ROOFING, WALL PANELS, HEATING, VENTILATION AND AIR CONDITIONING DUCTS AND OTHER CUSTOM ARCHITECTURAL METAL ITEMS AND PRODUCTS FOR COMMERCIAL, INDUSTRIAL, RESIDENTIAL AND OFFICE BUILDINGS (U.S. CLS. 100, 103 AND 106).

FIRST USE 1-1-1913; IN COMMERCE 1-1-2003.

HENRY S. ZAK, EXAMINING ATTORNEY

SN 85-145,352. NUTRASOURCE LLC, MIAMI, FL. FILED 10-5-2010.

NUTRAVIVE

THE MARK CONSISTS OF STANDARD CHARACTERS WITHOUT CLAIM TO ANY PARTICULAR FONT, STYLE, SIZE, OR COLOR.

#### CLASS 5—PHARMACEUTICALS

FOR DIETARY SUPPLEMENTS CONSISTING OF VITAMINS, MINERALS, HERBS, FIBER, NUTRACEUTICALS, OR PROTEIN IN TABLET, POWDER, CAPSULE OR LIQUID FORM; NUTRITIONAL DRINK MIXES (U.S. CLS. 6, 18, 44, 46, 51 AND 52).

#### CLASS 35—ADVERTISING AND BUSINESS

FOR ON-LINE RETAIL STORE SERVICES FEATURING DIETARY SUPPLEMENTS CONSISTING OF VITAMINS, MINERALS, HERBS, FIBER, NUTRACEUTICALS, OR PROTEIN IN TABLET, POWDER, CAPSULE OR LIQUID FORM, NUTRITIONAL DRINK MIXES (U.S. CLS. 100, 101 AND 102).

HENRY S. ZAK, EXAMINING ATTORNEY

SN 85-145,485. BITCENTRAL, INC., NEWPORT BEACH, CA.  
FILED 10-5-2010.

PRECIS

THE MARK CONSISTS OF STANDARD CHARACTERS WITHOUT CLAIM TO ANY PARTICULAR FONT, STYLE, SIZE, OR COLOR.

#### CLASS 9—ELECTRICAL AND SCIENTIFIC APPARATUS

FOR MEDIA AND NEWS PRODUCTION MANAGEMENT AND VIDEO PLAY-OUT SYSTEMS COMPRISED OF SOFTWARE FOR USE IN PRODUCING, EDITING, TIMING, ORGANIZING AND RUNNING NEWS BROADCASTS SOLD EXCLUSIVELY TO NEWS BROADCASTING ORGANIZATIONS (U.S. CLS. 21, 23, 26, 36 AND 38).

FIRST USE 4-0-2004; IN COMMERCE 4-0-2004.

#### CLASS 42—SCIENTIFIC AND COMPUTER SERVICES

FOR COMPUTER SOFTWARE AS A SERVICE THAT INTEGRATES WITH NEWSROOM COMPUTER SYSTEMS, MANAGES THE INGESTING OF MEDIA AND NEWS INFORMATION AND DATA, AND PROVIDES EDITING OF PLAY OUT AND ARCHIVING (U.S. CLS. 100 AND 101).

FIRST USE 4-0-2004; IN COMMERCE 4-0-2004.

JAMES GRIFFIN, EXAMINING ATTORNEY

SN 85-145,993. BOARD OF REGENTS OF THE UNIVERSITY  
SYSTEM OF GEORGIA, ATLANTA, GA. FILED 10-6-2010.



OWNER OF U.S. REG. NOS. 2,334,549, 3,725,163 AND OTHERS.

NO CLAIM IS MADE TO THE EXCLUSIVE RIGHT TO USE "COLLEGE", APART FROM THE MARK AS SHOWN.

THE MARK CONSISTS OF THE WORDS "GEORGIA COLLEGE" ARCHED ON TWO LINES FORMING AN OVAL SHAPE, AND AN IMAGE OF A BOBCAT FACE IN THE CENTER OF THE OVAL SHAPED "GEORGIA COLLEGE".

SEC. 2(F) AS TO "GEORGIA COLLEGE" .

**CLASS 6—METAL GOODS**

FOR METAL KEY CHAINS; METAL LICENSE PLATES (U.S. CLS. 2, 12, 13, 14, 23, 25 AND 50).

**CLASS 14—JEWELRY**

FOR CHARMS; CLOCKS AND WATCHES; JEWELRY; LAPEL PINS; PENDANTS; RINGS (U.S. CLS. 2, 27, 28 AND 50).

**CLASS 16—PAPER GOODS AND PRINTED MATTER**

FOR BINDERS; DAY PLANNERS; DECALS; DOCUMENT PORTFOLIOS; ENVELOPES; FOLDERS; NOTE CARDS; NOTE PAPER; NOTEBOOKS; PENCILS; PENS; POSTCARDS; STATIONERY; STATIONERY-TYPE PORTFOLIOS (U.S. CLS. 2, 5, 22, 23, 29, 37, 38 AND 50).

**CLASS 18—LEATHER GOODS**

FOR BACKPACKS; BOOK BAGS; GYM BAGS; MESSENGER BAGS; SCHOOL BAGS; TRAVEL BAGS; UMBRELLAS (U.S. CLS. 1, 2, 3, 22 AND 41).

**CLASS 21—HOUSEWARES AND GLASS**

FOR CUPS AND MUGS; FOAM DRINK HOLDERS; INSULATED CONTAINERS FOR FOOD OR BEVERAGE FOR DOMESTIC USE; LUNCH BOXES; PLASTIC WATER BOTTLES SOLD EMPTY (U.S. CLS. 2, 13, 23, 29, 30, 33, 40 AND 50).

**CLASS 25—CLOTHING**

FOR GOLF SHIRTS; HATS; PANTS; SHIRTS; SHORTS; SWEAT SHIRTS; T-SHIRTS; TIES (U.S. CLS. 22 AND 39).

**CLASS 41—EDUCATION AND ENTERTAINMENT**

FOR EDUCATIONAL SERVICES, NAMELY, PROVIDING COURSES OF INSTRUCTION AT THE UNIVERSITY LEVEL AND DISTRIBUTION OF COURSE MATERIAL IN CONNECTION THEREWITH; ENTERTAINMENT IN THE NATURE OF COMPETITIONS IN THE FIELD OF ATHLETICS (U.S. CLS. 100, 101 AND 107).

SUSAN RICHARDS, EXAMINING ATTORNEY

SN 85-146,308. COMMIT BUSINESS SOLUTIONS LTD., HOLON, ISRAEL, FILED 10-6-2010.

**CommitCRM**

THE MARK CONSISTS OF STANDARD CHARACTERS WITHOUT CLAIM TO ANY PARTICULAR FONT, STYLE, SIZE, OR COLOR.

**CLASS 9—ELECTRICAL AND SCIENTIFIC APPARATUS**

FOR DOWNLOADABLE COMPUTER SOFTWARE FOR AUTOMATING AND MANAGING ALL ASPECTS OF BUSINESS, NAMELY, SERVICE TRACKING, ASSET MANAGEMENT, HELPDESK, BILLING AND INVOICING, INVENTORY CONTROL, DISPATCHING, SALES, DOCUMENT MANAGEMENT, CLIENT RELATIONSHIP MANAGEMENT, KNOWLEDGE BASE, REMOTE MONITORING AND MANAGEMENT, TICKETING AND EMPLOYEE EFFICIENCY (U.S. CLS. 21, 23, 26, 36 AND 38). FIRST USE 1-31-2003; IN COMMERCE 1-31-2004.

**CLASS 42—SCIENTIFIC AND COMPUTER SERVICES**

FOR APPLICATION SERVICE PROVIDER (ASP) FEATURING SOFTWARE FOR AUTOMATING AND MANAGING ALL ASPECTS OF BUSINESS, NAMELY, SERVICE TRACKING, ASSET MANAGEMENT, HELPDESK, BILLING AND INVOICING, INVENTORY CONTROL, DISPATCHING, SALES, DOCUMENT MANAGEMENT, CLIENT RELATIONSHIP MANAGEMENT, KNOWLEDGE BASE, REMOTE MONITORING AND MANAGEMENT, TICKETING AND EMPLOYEE EFFICIENCY (U.S. CLS. 100 AND 101).

FIRST USE 1-31-2003; IN COMMERCE 1-31-2004.  
ALICIA COLLINS, EXAMINING ATTORNEY

SN 85-146,581. SALADO SALES, INC., TEMPLE, TX. FILED 10-6-2010.



OWNER OF U.S. REG. NO. 3,403,435.  
NO CLAIM IS MADE TO THE EXCLUSIVE RIGHT TO USE "FOODS", APART FROM THE MARK AS SHOWN.  
THE MARK CONSISTS OF THE WORD "DOUBLE" WITH THE LETTER "S" BEHIND IT, WITHIN AN OVAL, IMPOSED ON TOP OF A RIBBON SHAPE, WITH THE WORD "FOODS" DISPLAYED AT THE VERY TOP OF THE RIBBON SHAPE.

**CLASS 29—MEATS AND PROCESSED FOODS**

FOR FRENCH ONION DIP, CHEESE DIP AND BEAN DIP (U.S. CL. 46).  
FIRST USE 10-4-2010; IN COMMERCE 10-4-2010.

**CLASS 30—STAPLE FOODS**

FOR MAYONNAISE, MUSTARD, KETCHUP AND SALSA DIP (U.S. CL. 46).  
FIRST USE 2-1-2010; IN COMMERCE 2-1-2010.  
MARLENE BELL, EXAMINING ATTORNEY

SN 85-147,132. IRIDIAN GROUP, INC., OMAHA, NE. FILED 10-7-2010.

SN 85-147,190. NUTRASOURCE LLC, MIAMI, FL. FILED 10-7-2010.

## IRIDIAN GROUP

THE MARK CONSISTS OF STANDARD CHARACTERS WITHOUT CLAIM TO ANY PARTICULAR FONT, STYLE, SIZE, OR COLOR.

NO CLAIM IS MADE TO THE EXCLUSIVE RIGHT TO USE "GROUP", APART FROM THE MARK AS SHOWN.

### CLASS 35—ADVERTISING AND BUSINESS

FOR ADVERTISING AND MARKETING; ADVERTISING CONSULTATION; DESIGN OF ADVERTISING MATERIALS FOR OTHERS; DESIGN OF INTERNET ADVERTISING; INTERNET ADVERTISING SERVICES; MARKETING CONSULTING; PREPARING PROMOTIONAL AND MERCHANDISING MATERIAL FOR OTHERS (U.S. CLS. 100, 101 AND 102).

FIRST USE 1-1-2011; IN COMMERCE 1-1-2011.

### CLASS 42—SCIENTIFIC AND COMPUTER SERVICES

FOR CREATION, DESIGN, DEVELOPMENT AND MAINTENANCE OF WEB SITES FOR THIRD PARTIES (U.S. CLS. 100 AND 101).

FIRST USE 1-1-2011; IN COMMERCE 1-1-2011.  
PAUL MORENO, EXAMINING ATTORNEY

SN 85-147,146. GILBANE DEVELOPMENT COMPANY, PROVIDENCE, RI. FILED 10-7-2010.

## THE NEXT LEVEL OF STUDENT HOUSING

THE MARK CONSISTS OF STANDARD CHARACTERS WITHOUT CLAIM TO ANY PARTICULAR FONT, STYLE, SIZE, OR COLOR.

NO CLAIM IS MADE TO THE EXCLUSIVE RIGHT TO USE "STUDENT HOUSING", APART FROM THE MARK AS SHOWN.

### CLASS 36—INSURANCE AND FINANCIAL

FOR REAL ESTATE SERVICES, NAMELY, PROPERTY MANAGEMENT SERVICES IN THE FIELD OF STUDENT HOUSING (U.S. CLS. 100, 101 AND 102).

### CLASS 37—CONSTRUCTION AND REPAIR

FOR REAL ESTATE DEVELOPMENT SERVICES, CONSTRUCTION SERVICES, CONSTRUCTION PROJECT MANAGEMENT SERVICES IN THE FIELD OF STUDENT HOUSING; AND CONSULTING SERVICES IN THE FIELD OF STUDENT HOUSING DEVELOPMENT, CONSTRUCTION AND MAINTENANCE (U.S. CLS. 100, 103 AND 106).

EMILY CHUO, EXAMINING ATTORNEY

nutravive



THE COLOR(S) DARK PURPLE, LIGHT PURPLE AND WHITE IS/ARE CLAIMED AS A FEATURE OF THE MARK.

THE MARK CONSISTS OF A WHITE RECTANGLE ON TOP OF A DARK PURPLE RECTANGLE. THE WORD "NUTRAVIVE" APPEARS IN THE TOP WHITE RECTANGLE. THE WORD "NUTRA" IS IN DARK PURPLE AND "VIVE" IS IN LIGHT PURPLE. THE DOT OF THE LETTER "I" IS A STYLIZED DARK PURPLE LEAF. THE WORD "NUTRAVIVE" IN THE BOTTOM DARK PURPLE RECTANGLE FEATURES "NUTRA" IN WHITE AND "VIVE" IN LIGHT PURPLE. THE DOT OF THE LETTER "I" IS A WHITE STYLIZED LEAF.

### CLASS 5—PHARMACEUTICALS

FOR DIETARY SUPPLEMENTS CONSISTING OF VITAMINS, MINERALS, HERBS, FIBER, NUTRACEUTICALS, OR PROTEIN IN TABLET, POWDER, CAPSULE OR LIQUID FORM; NUTRITIONAL DRINK MIXES (U.S. CLS. 6, 18, 44, 46, 51 AND 52).

### CLASS 35—ADVERTISING AND BUSINESS

FOR ON-LINE RETAIL STORE SERVICES FEATURING DIETARY SUPPLEMENTS CONSISTING OF VITAMINS, MINERALS, HERBS, FIBER, NUTRACEUTICALS, OR PROTEIN IN TABLET, POWDER, CAPSULE OR LIQUID FORM, NUTRITIONAL DRINK MIXES (U.S. CLS. 100, 101 AND 102).

HENRY S. ZAK, EXAMINING ATTORNEY

SN 85-147,712. JIRAN SOFT, SEOUL, REPUBLIC OF KOREA, FILED 10-7-2010.



THE MARK CONSISTS OF THE WORDS "COOLMESSENGER" WITH A PENGUIN TO THE LEFT OF THE "C" WITH A CROWN ON ITS HEAD.

**CLASS 9—ELECTRICAL AND SCIENTIFIC APPARATUS**

FOR RECORDED COMPUTER SOFTWARE USED FOR TRANSMITTING ELECTRONIC MAIL; RECORDED COMPUTER PROGRAMS USED FOR TRANSMITTING INSTANT MESSAGES; COMPUTER PROGRAMS USED FOR ENSURING THE SECURITY OF INSTANT MESSAGES; COMPUTER SOFTWARE FOR WIRELESS CONTENT DELIVERY; COMPUTER SOFTWARE FOR ENCRYPTION (U.S. CLS. 21, 23, 26, 36 AND 38).

**CLASS 42—SCIENTIFIC AND COMPUTER SERVICES**

FOR COMPUTER VIRUS PROTECTION SERVICES; COMPUTER SECURITY CONSULTANCY; COMPUTER SOFTWARE DEVELOPMENT; COMPUTER SOFTWARE DESIGN; UPDATING OF COMPUTER SOFTWARE; COMPUTER SOFTWARE RESEARCH; MAINTENANCE OF COMPUTER SOFTWARE; COMPUTER SOFTWARE CONSULTATION; COMPUTER PROGRAMMING; DEVELOPMENT OF COMPUTER PROGRAMS (U.S. CLS. 100 AND 101).

ELLEN B. AWRICH, EXAMINING ATTORNEY

**CLASS 44—MEDICAL, BEAUTY AND AGRICULTURAL SERVICES**

FOR MEDICAL CONSULTATION SERVICES, NAMELY, MEDICAL CONSULTATION IN THE FIELD OF DEVICES, INSTRUMENTS AND TECHNIQUES FOR ENDOVASCULAR PROCEDURES, AND THE FIELD OF KITS COMPRISING SUCH DEVICES, INSTRUMENTS AND INSTRUCTIONS FOR PRACTICING THE TECHNIQUES, AS WELL AS CONSULTATION REGARDING THE PARTS AND ACCESSORIES FOR ALL OF THE FOREGOING MEDICAL DEVICES, INSTRUMENTS AND TECHNIQUES; MEDICAL CONSULTATION SERVICES, NAMELY, MEDICAL CONSULTATION SERVICES FOR PHYSICIANS AND MEDICAL RESEARCHERS IN THE FIELD OF MEDICAL DEVICES, INSTRUMENTS AND TECHNIQUES FOR ENDOVASCULAR PROCEDURES, AND THE FIELD OF KITS COMPRISING SUCH DEVICES, INSTRUMENTS AND INSTRUCTIONS FOR PRACTICING THE TECHNIQUES, INCLUDING CONSULTATION WITH PHYSICIANS AND MEDICAL RESEARCHERS REGARDING SUCH MEDICAL DEVICES, INSTRUMENTS, AND TECHNIQUES; AND PROVIDING ONLINE MEDICAL INFORMATION FOR PHYSICIANS AND PATIENTS REGARDING SUCH MEDICAL DEVICES, INSTRUMENTS AND TECHNIQUES (U.S. CLS. 100 AND 101).

ROBIN CHOSID, EXAMINING ATTORNEY

---

SN 85-149,325. ATHEROMED, INC., MENLO PARK, CA.  
FILED 10-11-2010.

---

SN 85-149,326. ATHEROMED, INC., MENLO PARK, CA.  
FILED 10-11-2010.

# PHOENIX

## PHOENIX ATHERECTOMY

THE MARK CONSISTS OF STANDARD CHARACTERS WITHOUT CLAIM TO ANY PARTICULAR FONT, STYLE, SIZE, OR COLOR.

**CLASS 10—MEDICAL APPARATUS**

FOR MEDICAL DEVICES AND INSTRUMENTS, NAMELY, MEDICAL DEVICES AND INSTRUMENTS FOR ENDOVASCULAR PROCEDURES, KITS COMPRISING MEDICAL DEVICES AND INSTRUMENTS FOR ENDOVASCULAR PROCEDURES AND INSTRUCTIONS SOLD THEREWITH, AND PARTS AND FITTINGS FOR ALL OF THE FOREGOING MEDICAL DEVICES AND INSTRUMENTS (U.S. CLS. 26, 39 AND 44).

**CLASS 41—EDUCATION AND ENTERTAINMENT**

FOR EDUCATIONAL SERVICES, NAMELY, CONDUCTING TRAINING, WORKSHOPS AND CONFERENCES IN THE FIELD OF DEVICES, INSTRUMENTS AND TECHNIQUES FOR ENDOVASCULAR PROCEDURES, AND IN USING KITS COMPRISING SUCH DEVICES, INSTRUMENTS AND INSTRUCTIONS FOR PRACTICING THE TECHNIQUES, AND IN USING THE PARTS AND ACCESSORIES FOR ALL OF THE FOREGOING MEDICAL DEVICES, INSTRUMENTS AND TECHNIQUES (U.S. CLS. 100, 101 AND 107).

THE MARK CONSISTS OF STANDARD CHARACTERS WITHOUT CLAIM TO ANY PARTICULAR FONT, STYLE, SIZE, OR COLOR.

NO CLAIM IS MADE TO THE EXCLUSIVE RIGHT TO USE "ATHERECTOMY", APART FROM THE MARK AS SHOWN.

**CLASS 41—EDUCATION AND ENTERTAINMENT**

FOR EDUCATIONAL SERVICES, NAMELY, CONDUCTING TRAINING, WORKSHOPS AND CONFERENCES IN THE FIELD OF DEVICES, INSTRUMENTS AND TECHNIQUES FOR THE REMOVAL OF PLAQUE AND BLOCKAGE FROM A BLOOD VESSEL AND/OR WIDENING OF BLOOD VESSELS NARROWED BY DISEASE, AND IN USING KITS COMPRISING SUCH DEVICES, INSTRUMENTS AND INSTRUCTIONS FOR PRACTICING THE TECHNIQUES, AND IN USING THE PARTS AND ACCESSORIES FOR ALL OF THE FOREGOING MEDICAL DEVICES, INSTRUMENTS AND TECHNIQUES (U.S. CLS. 100, 101 AND 107).

**CLASS 44—MEDICAL, BEAUTY AND AGRICULTURAL SERVICES**

FOR MEDICAL CONSULTATION SERVICES, NAMELY, MEDICAL CONSULTATION IN THE FIELD OF DEVICES, INSTRUMENTS AND TECHNIQUES FOR THE REMOVAL OF PLAQUE AND BLOCKAGE FROM A BLOOD VESSEL AND/OR WIDENING OF BLOOD VESSELS NARROWED BY DISEASE, AND THE FIELD OF KITS COMPRISING SUCH DEVICES, INSTRUMENTS AND INSTRUCTIONS FOR PRACTICING THE TECHNIQUES, AS WELL AS CONSULTING REGARDING THE PARTS AND ACCESSORIES FOR ALL OF THE FOREGOING MEDICAL DEVICES, INSTRUMENTS AND TECHNIQUES; MEDICAL CONSULTATION SERVICES, NAMELY, MEDICAL CONSULTATION SERVICES FOR PHYSICIANS AND MEDICAL RESEARCHERS IN THE FIELD OF MEDICAL DEVICES, INSTRUMENTS AND TECHNIQUES FOR THE REMOVAL OF PLAQUE AND BLOCKAGE FROM A BLOOD VESSEL AND/OR WIDENING OF BLOOD VESSELS NARROWED BY DISEASE, AND THE FIELD OF KITS COMPRISING SUCH DEVICES, INSTRUMENTS AND INSTRUCTIONS FOR PRACTICING THE TECHNIQUES, INCLUDING CONSULTATION WITH PHYSICIANS AND MEDICAL RESEARCHERS REGARDING SUCH MEDICAL DEVICES, INSTRUMENTS, AND TECHNIQUES; AND PROVIDING ONLINE MEDICAL INFORMATION FOR PHYSICIANS AND PATIENTS REGARDING SUCH MEDICAL DEVICES, INSTRUMENTS AND TECHNIQUES (U.S. CLS. 100 AND 101).

ROBIN CHOSID, EXAMINING ATTORNEY

SN 85-149,395. VISION EXPLORATION, L.L.C., MADISON, MS. FILED 10-11-2010.



NO CLAIM IS MADE TO THE EXCLUSIVE RIGHT TO USE "EXPLORATION", APART FROM THE MARK AS SHOWN.

THE COLOR(S) GREEN, RED, WHITE AND BLACK IS/ARE CLAIMED AS A FEATURE OF THE MARK.

THE MARK CONSISTS OF THE STYLIZED WORDING "VISION EXPLORATION" IN THE COLOR WHITE FEATURING A RED CRESCENT AND A GREEN CRESCENT TO THE LEFT OF THE WORDING ALL ON A BLACK BACKGROUND.

**CLASS 35—ADVERTISING AND BUSINESS**

FOR MANAGING THE EXPLORATION, PRODUCTION AND OPERATIONS OF NATURAL GAS AND OIL PROPERTIES FOR OTHERS (U.S. CLS. 100, 101 AND 102).

FIRST USE 12-1-2009; IN COMMERCE 12-1-2009.

**CLASS 42—SCIENTIFIC AND COMPUTER SERVICES**

FOR ANALYSIS SERVICES FOR OIL FIELD EXPLORATION; EXPLORATION AND SEARCHING OF OIL AND GAS; GAS EXPLORATION; GEOPHYSICAL EXPLORATION FOR THE OIL, GAS AND MINING INDUSTRIES; OIL EXPLORATION; OIL FIELD EXPLORATION; PETROLEUM EXPLORATION (U.S. CLS. 100 AND 101).

FIRST USE 12-1-2009; IN COMMERCE 12-1-2009.  
BERYL GARDNER, EXAMINING ATTORNEY

SN 85-149,855. N-LAB, LLC, SOUTH SALEM, NY. FILED 10-11-2010.

# BUCK UP

THE MARK CONSISTS OF STANDARD CHARACTERS WITHOUT CLAIM TO ANY PARTICULAR FONT, STYLE, SIZE, OR COLOR.

**CLASS 41—EDUCATION AND ENTERTAINMENT**

FOR BUSINESS EDUCATION AND TRAINING SERVICES, NAMELY, DEVELOPING, AND FACILITATING CUSTOMIZED IN-COMPANY LEADERSHIP AND EXECUTIVE DEVELOPMENT PROGRAMS, PROVIDING EXECUTIVE COACHING SERVICES, AND PROVIDING PUBLIC AND IN-COMPANY KEYNOTE PRESENTATIONS TO BUSINESS LEADERS; LIFE COACHING SERVICES IN THE FIELD OF LEADERSHIP, PERSONAL DEVELOPMENT AND PROFESSIONAL DEVELOPMENT; PEER TO PEER COACHING SERVICES IN THE FIELD OF LEADERSHIP, PERSONAL DEVELOPMENT AND PROFESSIONAL DEVELOPMENT; PROVIDING GROUP COACHING AND LEARNING FORUMS IN THE FIELD OF LEADERSHIP DEVELOPMENT; PROVIDING GROUP COACHING IN THE FIELD OF LEADERSHIP, PERSONAL DEVELOPMENT AND PROFESSIONAL DEVELOPMENT (U.S. CLS. 100, 101 AND 107).

**CLASS 42—SCIENTIFIC AND COMPUTER SERVICES**

FOR COMPUTER SERVICES, NAMELY, CREATING AN ON-LINE COMMUNITY FOR REGISTERED USERS TO PARTICIPATE IN DISCUSSIONS, GET FEEDBACK FROM THEIR PEERS, FORM VIRTUAL COMMUNITIES, AND ENGAGE IN SOCIAL NETWORKING FEATURING COACHING, LEADERSHIP, PERSONAL DEVELOPMENT AND PROFESSIONAL DEVELOPMENT; PROVIDING A WEBSITE THAT ENABLES USERS TO SUBSCRIBE TO COACHING, MENTORING, AND/OR EDUCATIONAL SERVICES AND TO ENABLE USERS TO AUTHOR AND PUBLISH INSTRUCTIONAL CONTENT FOR OTHERS (U.S. CLS. 100 AND 101).

KELLEY WELLS, EXAMINING ATTORNEY

SN 85-150,171. REALIZATION TECHNOLOGIES, INC., SAN JOSE, CA. FILED 10-12-2010.

# REALIZATION

THE MARK CONSISTS OF STANDARD CHARACTERS WITHOUT CLAIM TO ANY PARTICULAR FONT, STYLE, SIZE, OR COLOR.

OWNER OF U.S. REG. NO. 2,906,441.

**CLASS 41—EDUCATION AND ENTERTAINMENT**

FOR EDUCATION SERVICES, NAMELY, PROVIDING TUTORIAL SESSIONS IN THE FIELD(S) OF PROJECT MANAGEMENT SOFTWARE; TRAINING IN THE USE OF PROJECT MANAGEMENT SOFTWARE (U.S. CLS. 100, 101 AND 107).

FIRST USE 3-1-2003; IN COMMERCE 3-1-2003.

**CLASS 42—SCIENTIFIC AND COMPUTER SERVICES**

FOR COMPUTER SOFTWARE DEVELOPMENT, COMPUTER PROGRAMMING AND MAINTENANCE OF COMPUTER SOFTWARE FOR PROJECT MANAGEMENT; COMPUTER SOFTWARE INSTALLATION AND MAINTENANCE; DESIGN, INSTALLATION, UPDATING AND MAINTENANCE OF COMPUTER SOFTWARE; INSTALLATION OF COMPUTER SOFTWARE; MAINTENANCE AND UPDATING OF COMPUTER SOFTWARE; MAINTENANCE AND UPGRADING OF COMPUTER SOFTWARE (U.S. CLS. 100 AND 101).

FIRST USE 3-1-2003; IN COMMERCE 3-1-2003.

GINA HAYES, EXAMINING ATTORNEY

---

SN 85-150,180. REALIZATION TECHNOLOGIES, INC., SAN JOSE, CA. FILED 10-12-2010.

**REALIZATION CONCERTO**

THE MARK CONSISTS OF STANDARD CHARACTERS WITHOUT CLAIM TO ANY PARTICULAR FONT, STYLE, SIZE, OR COLOR.

OWNER OF U.S. REG. NO. 2,906,441.

**CLASS 9—ELECTRICAL AND SCIENTIFIC APPARATUS**

FOR COMPUTER SOFTWARE FOR PROJECT MANAGEMENT (U.S. CLS. 21, 23, 26, 36 AND 38).

**CLASS 41—EDUCATION AND ENTERTAINMENT**

FOR EDUCATION SERVICES, NAMELY, PROVIDING TUTORIAL SESSIONS IN THE FIELD(S) OF PROJECT MANAGEMENT SOFTWARE; TRAINING IN THE USE OF PROJECT MANAGEMENT SOFTWARE (U.S. CLS. 100, 101 AND 107).

**CLASS 42—SCIENTIFIC AND COMPUTER SERVICES**

FOR COMPUTER SOFTWARE DEVELOPMENT, COMPUTER PROGRAMMING AND MAINTENANCE OF COMPUTER SOFTWARE FOR PROJECT MANAGEMENT; COMPUTER SOFTWARE INSTALLATION AND MAINTENANCE; DESIGN, INSTALLATION, UPDATING AND MAINTENANCE OF COMPUTER SOFTWARE; INSTALLATION OF COMPUTER SOFTWARE; MAINTENANCE AND UPDATING OF COMPUTER SOFTWARE; MAINTENANCE AND UPGRADING OF COMPUTER SOFTWARE (U.S. CLS. 100 AND 101).

GINA HAYES, EXAMINING ATTORNEY

SN 85-150,268. FREE & CLEAR, INC., SEATTLE, WA. FILED 10-12-2010.

**QUIT FOR BABY**

THE MARK CONSISTS OF STANDARD CHARACTERS WITHOUT CLAIM TO ANY PARTICULAR FONT, STYLE, SIZE, OR COLOR.

**CLASS 16—PAPER GOODS AND PRINTED MATTER**

FOR PUBLICATIONS AND PRINTED MATERIALS, NAMELY, PAMPHLETS, BROCHURES, BOOKLETS, MAGAZINES, WORKBOOKS, MANUALS, AND POSTERS, FEATURING HEALTH INFORMATION RELATING TO CESSATION OF THE USE OF TOBACCO PRODUCTS (U.S. CLS. 2, 5, 22, 23, 29, 37, 38 AND 50).

**CLASS 44—MEDICAL, BEAUTY AND AGRICULTURAL SERVICES**

FOR PROVIDING COUNSELING SERVICES AND CONSULTATION SERVICES VIA TELEPHONE AND A GLOBAL COMPUTER NETWORK DESIGNED TO ASSIST PREGNANT WOMEN AND NEW MOTHERS IN THE CESSATION OF THE USE OF TOBACCO PRODUCTS; HEALTH INFORMATION SERVICES, NAMELY, PROVIDING INFORMATION TO ASSIST OTHERS IN THE CESSATION OF USE OF TOBACCO PRODUCTS ACCESSED VIA TELEPHONE AND A GLOBAL COMPUTER NETWORK (U.S. CLS. 100 AND 101).

KRISTINA MORRIS, EXAMINING ATTORNEY

---

SN 85-150,608. SPANFELLER MEDIA GROUP, INC., NEW YORK, NY. FILED 10-12-2010.



NO CLAIM IS MADE TO THE EXCLUSIVE RIGHT TO USE "MEAL", APART FROM THE MARK AS SHOWN.

THE MARK CONSISTS OF THE WORDS "THE DAILY MEAL" WITH THE WORDS "ALL THE FOOD THAT'S FIT TO EAT" UNDERNEATH THEM, ALL OF THE FOREGOING TO THE RIGHT OF AN ILLUSTRATION OF A PLATE WITH A FORK AND KNIFE ON IT.

**CLASS 35—ADVERTISING AND BUSINESS**

FOR ADVERTISING AND BUSINESS SERVICES, NAMELY, PROVIDING AN ONLINE WEBSITE WHERE ADVERTISERS, MARKETERS, AND CONTENT PROVIDERS CAN INTERACT WITH USERS FOR ADVERTISING, BRANDING, AND PROMOTING KNOWLEDGE, PRODUCTS AND SERVICES, ON BEHALF OF THEMSELVES AND OTHERS, AND FOR EVALUATING AND RATING THE SAME, ALL THE FOREGOING RELEVANT TO FOOD-RELATED TOPICS; PROVIDING A WEBSITE FOR CONNECTING SELLERS WITH BUYERS IN THE FIELD OF FOOD AND FOOD-RELATED PRODUCTS AND SERVICES (U.S. CLS. 100, 101 AND 102).

**CLASS 41—EDUCATION AND ENTERTAINMENT**

FOR ON-LINE JOURNALS, NAMELY, BLOGS FEATURING FOOD, WINE AND RESTAURANTS AND OTHER FOOD-RELATED TOPICS (U.S. CLS. 100, 101 AND 107).

**CLASS 43—HOTEL AND RESTAURANT SERVICES**

FOR PROVIDING A WEBSITE FEATURING NEWS AND INFORMATION IN THE FIELD OF FOOD AND WINE IN THE FORM OF RESTAURANT MEALS; PROVIDING A WEBSITE FEATURING INFORMATION ABOUT FOOD AND WINE PAIRING; PROVIDING A WEBSITE FEATURING INFORMATION ABOUT RESTAURANTS; PROVIDING AN INTERACTIVE WEBSITE IN THE FIELD OF RECIPES (U.S. CLS. 100 AND 101).  
JAMES GRIFFIN, EXAMINING ATTORNEY

**CLASS 9—ELECTRICAL AND SCIENTIFIC APPARATUS**

FOR CLEAR PROTECTIVE COVERS SPECIALLY ADAPTED FOR PERSONAL ELECTRONIC DEVICES (U.S. CLS. 21, 23, 26, 36 AND 38).  
CHRISTINA SOBRAL, EXAMINING ATTORNEY

SN 85-150,669. MEERS, COCO B., CHICAGO, IL. FILED 10-12-2010.

**PRETTY QUICK**

THE MARK CONSISTS OF STANDARD CHARACTERS WITHOUT CLAIM TO ANY PARTICULAR FONT, STYLE, SIZE, OR COLOR.

**CLASS 35—ADVERTISING AND BUSINESS**

FOR PROVIDING BUSINESS SERVICES TO BEAUTY SALONS AND SPA BUSINESSES, NAMELY, ONLINE APPOINTMENT SCHEDULING SERVICES FOR HAIR, NAIL, AND COSMETIC SKIN CARE SERVICES AND SPA SERVICES (U.S. CLS. 100, 101 AND 102).

**CLASS 44—MEDICAL, BEAUTY AND AGRICULTURAL SERVICES**

FOR PROVIDING A WEBSITE FOR OTHERS FOR MAKING RESERVATIONS AND BOOKINGS AT BEAUTY SALONS AND HEALTH SPAS FOR HAIR, NAIL, AND COSMETIC SKIN CARE SERVICES, AND BEAUTY, HEALTH, AND WELLNESS SPA SERVICES (U.S. CLS. 100 AND 101).  
KIM MONINGHOFF, EXAMINING ATTORNEY

SN 85-150,749. CASTERLINE, ROBERT, NAPLES, FL. FILED 10-12-2010.

**ARTWORK ARMOUR**

THE MARK CONSISTS OF STANDARD CHARACTERS WITHOUT CLAIM TO ANY PARTICULAR FONT, STYLE, SIZE, OR COLOR.

NO CLAIM IS MADE TO THE EXCLUSIVE RIGHT TO USE "ARTWORK", APART FROM THE MARK AS SHOWN.

**CLASS 6—METAL GOODS**

FOR METAL CLAMP-TYPE FASTENERS FOR HOLDING IN PLACE CURTAINS, TARPS, CANVAS, CLOTH AND FILM COVERING MATERIAL (U.S. CLS. 2, 12, 13, 14, 23, 25 AND 50).

SN 85-151,011. TEXAS A&M UNIVERSITY, COLLEGE STATION, TX. FILED 10-12-2010.

**GIG 'EM AGGIES**

THE MARK CONSISTS OF STANDARD CHARACTERS WITHOUT CLAIM TO ANY PARTICULAR FONT, STYLE, SIZE, OR COLOR.

OWNER OF U.S. REG. NOS. 1,811,969 AND 1,979,207.

**CLASS 14—JEWELRY**

FOR CHARMS; CLOCKS AND WATCHES; EARRINGS; JEWELRY; ORNAMENTAL PINS; RINGS; RUBBER OR SILICON WRISTBANDS IN THE NATURE OF A BRACELET (U.S. CLS. 2, 27, 28 AND 50).  
FIRST USE 12-31-1985; IN COMMERCE 12-31-1985.

**CLASS 16—PAPER GOODS AND PRINTED MATTER**

FOR ADHESIVE NOTE PADS; ANNOUNCEMENT CARDS; ART PRINTS; ART PRINTS COMPRISED OF DIGITAL ILLUSTRATIONS ORIGINATING FROM PHOTOGRAPHS; BASEBALL CARDS; BUMPER STICKERS; CALENDARS; CARDS BEARING UNIVERSAL GREETINGS; CHECKBOOK COVERS; CHILDREN'S BOOKS; DECALS; DESK STANDS AND HOLDERS FOR PENS, PENCILS, AND INK; DESKTOP BUSINESS CARD HOLDERS; DISPOSABLE NAPKINS; ENVELOPES; GIFT WRAPPING PAPER; GLOBES; GREETINGS CARDS AND POSTCARDS; GROCERY BAGS; MERCHANDISE BAGS; MONEY CLIPS; MURALS; NOTE BOOKS; NOTE PADS; NOTEBOOKS; NOTEPADS; PAPER TABLE LINENS; PAPER TABLECLOTHS; PAPERWEIGHTS; PENCILS; PENS; PHOTOGRAPHS; PICTURES; POSTERS; PRINTS; REMOVABLE TATTOOS; STATIONERY; STICKERS; TABLE CLOTHS OF PAPER; TABLE LINENS OF PAPER; TABLE MATS OF PAPER; THREE-RING BINDERS; TRADING CARDS (U.S. CLS. 2, 5, 22, 23, 29, 37, 38 AND 50).  
FIRST USE 12-31-1985; IN COMMERCE 12-31-1985.

**CLASS 21—HOUSEWARES AND GLASS**

FOR BEVERAGE GLASSWARE; BOWLS; BUCKETS; COASTERS NOT OF PAPER AND NOT BEING TABLE LINEN; COFFEE CUPS, TEA CUPS AND MUGS; CONTAINERS FOR HOUSEHOLD USE; COOKING UTENSILS, NAMELY, GRILL COVERS; COOKING UTENSILS, NAMELY, GRILLS; DECORATIVE CERAMIC TILES NOT FOR USE AS BUILDING MATERIALS; DECORATIVE GLASS; DECORATIVE PLATES; DINNERWARE; DISHES; DRINKING FLASKS; DRINKING GLASSES; FRAGRANCE OIL BURNERS; GARBAGE CANS; HOLIDAY ORNAMENTS OF CERAMIC; HOLIDAY ORNAMENTS OF PORCELAIN; HOUSEHOLD UTENSILS, NAMELY, KITCHEN TONGS; HOUSEHOLD UTENSILS, NAMELY, SPATULAS; HOUSEHOLD UTENSILS, NAMELY, TURNERS; INSULATING SLEEVE HOLDERS FOR BEVERAGE CANS; NEOPRENE ZIPPERED BOTTLE HOLDERS; PET FEEDING DISHES; PITCHERS; PLASTIC WATER BOTTLES SOLD EMPTY; PORTABLE COOLERS; SALT AND PEPPER SHAKERS; SPORTS BOTTLES SOLD EMPTY; TOOTHBRUSHES; TOOTH-PICK HOLDERS (U.S. CLS. 2, 13, 23, 29, 30, 33, 40 AND 50).

FIRST USE 12-31-1985; IN COMMERCE 12-31-1985.

**CLASS 25—CLOTHING**

FOR ATHLETIC APPAREL, NAMELY, SHIRTS, PANTS, JACKETS, FOOTWEAR, HATS AND CAPS, ATHLETIC UNIFORMS; ATHLETIC UNIFORMS; BANDANAS; BASEBALL CAPS; BASEBALL CAPS AND HATS; BATHING SUITS; BELTS; BOOTS; CHILDREN'S AND INFANT'S APPAREL, NAMELY, JUMPERS, OVER-ALL SLEEPWEAR, PAJAMAS, ROMPERS AND ONE-PIECE GARMENTS; COATS; FLEECE PULLOVERS; FLIP FLOPS; FOOTWEAR; GOLF SHIRTS; HATS; HOODED SWEATSHIRTS; JACKETS; LOUNGEWEAR; MOISTURE-WICKING SPORTS SHIRTS; PAJAMAS; POLO SHIRTS; RAIN BOOTS; SHOES; SOCKS; SWEAT JACKETS; SWEAT PANTS; SWEAT SHIRTS; SWEAT SUITS; SWEATSHIRTS; SWIM WEAR; T-SHIRTS; TANK TOPS; THONGS; TIES; UNDERGARMENTS; WEARABLE BLANKETS IN THE NATURE OF BLANKETS WITH SLEEVES; WRISTBANDS (U.S. CLS. 22 AND 39).

FIRST USE 12-31-1985; IN COMMERCE 12-31-1985.

**CLASS 28—TOYS AND SPORTING GOODS**

FOR ACTION FIGURES; BALLS FOR SPORTS; BOARD GAMES; BOBBLEHEAD DOLLS; CHRISTMAS STOCKINGS; CHRISTMAS TREE DECORATIONS; COVERS FOR GOLF CLUBS; DIVOT REPAIR TOOLS; DOMINOES; GOLF BAGS; GOLF BALLS; GOLF PUTTERS; PLAYING CARDS; PLUSH TOYS; TOY SNOW GLOBES (U.S. CLS. 22, 23, 38 AND 50).

FIRST USE 12-31-1985; IN COMMERCE 12-31-1985.

**CLASS 41—EDUCATION AND ENTERTAINMENT**

FOR ARRANGING AND CONDUCTING ATHLETIC COMPETITIONS; ARRANGING AND CONDUCTING EDUCATIONAL CONFERENCES; AUDIO RECORDING AND PRODUCTION; BOOK PUBLISHING; BUSINESS EDUCATION AND TRAINING SERVICES, NAMELY, DEVELOPING, AND FACILITATING CUSTOMIZED IN-COMPANY LEADERSHIP AND EXECUTIVE DEVELOPMENT PROGRAMS, PROVIDING EXECUTIVE COACHING SERVICES, AND PROVIDING PUBLIC AND IN-COMPANY KEYNOTE PRESENTATIONS TO BUSINESS LEADERS; EDUCATING AT UNIVERSITY OR COLLEGES; RESEARCH IN THE FIELD OF EDUCATION; SPORT CAMPS (U.S. CLS. 100, 101 AND 107).

FIRST USE 12-31-1930; IN COMMERCE 12-31-1930.  
BRENDAN REGAN, EXAMINING ATTORNEY

SN 85-151,178. ESTRATEGY CONSULTING LLC, DBA ESTRATEGY CONSULTING, CLINTON, MO. FILED 10-13-2010.



NO CLAIM IS MADE TO THE EXCLUSIVE RIGHT TO USE "CONSULTING", APART FROM THE MARK AS SHOWN.

THE COLOR(S) BLUE AND ORANGE IS/ARE CLAIMED AS A FEATURE OF THE MARK.

THE MARK CONSISTS OF THE WORDING "ESTRATEGY" IN BLUE AND "CONSULTING" IN ORANGE, AND A DESIGN FEATURING 14 SMALL DIAMONDS OR INVERTED SQUARES, SEVEN IN BLUE AND SEVEN IN ORANGE, IN FRONT OF THE WORDING IN THE MARK.

**CLASS 35—ADVERTISING AND BUSINESS**

FOR ARRANGING FOR PICKUP, DELIVERY, STORAGE AND TRANSPORTATION OF DOCUMENTS, PACKAGES, FREIGHT AND PARCELS VIA GROUND AND AIR CARRIERS; ARRANGING THE TRANSPORT OF VEHICLES OF INSURED PARTIES ON BEHALF OF THEIR INSURANCE COMPANIES FOR RESOLUTION OF INSURANCE CLAIMS; BUSINESS ADMINISTRATION IN THE FIELD OF TRANSPORT AND DELIVERY; BUSINESS MANAGEMENT CONSULTANCY IN THE FIELD OF TRANSPORT AND DELIVERY; BUSINESS MANAGEMENT IN THE FIELD OF TRANSPORT AND DELIVERY; CONSULTING IN THE FIELDS OF HEALTHCARE OPERATIONS MANAGEMENT AND HOSPITAL OPERATIONS MANAGEMENT; TRANSPORTATION LOGISTICS SERVICES, NAMELY, ARRANGING THE TRANSPORTATION OF GOODS FOR OTHERS; TRANSPORTATION LOGISTICS SERVICES, NAMELY, PLANNING AND SCHEDULING SHIPMENTS FOR USERS OF TRANSPORTATION SERVICES; TRANSPORTATION MANAGEMENT SERVICES, NAMELY, PLANNING AND COORDINATING TRANSPORTATION OF PEOPLE FOR OTHERS (U.S. CLS. 100, 101 AND 102).

FIRST USE 10-10-2008; IN COMMERCE 10-10-2008.

**CLASS 37—CONSTRUCTION AND REPAIR**

FOR BIO-HAZARD BIOLOGICAL CLEAN-UP SERVICES; HAZARDOUS WASTE DISPOSAL SERVICES (U.S. CLS. 100, 103 AND 106).

FIRST USE 10-10-2008; IN COMMERCE 10-10-2008.

**CLASS 39—TRANSPORTATION AND STORAGE**

FOR AIR CHARTER TRANSPORTATION SERVICES; AIR TRANSPORT; AIR TRANSPORT AND STORAGE OF GOODS; AIR TRANSPORT SERVICES; AIR TRANSPORTATION; AIR TRANSPORTATION OF PASSENGERS AND FREIGHT; AIRLINE TRANSPORTATION SERVICES; AMBULANCE TRANSPORT; ARMORED CAR TRANSPORT; BARGE TRANSPORT; BOAT TRANSPORT; BUS TRANSPORT; CAR TRANSPORT; CARGO SHIP TRANSPORT; HAZARDOUS WASTE TRANSPORTATION SERVICES; JUNK, TRASH AND DEBRIS REMOVAL; MEDICAL TRANSPORT SERVICES; PACKAGING AND PARCELLING OF GOODS FOR TRANSPORT PURPOSES, NAMELY, THE PACKING OF GOODS USING SUSTAINABLE OR BIODEGRADABLE PACKAGING AND SHIPPING MATERIALS; PACKAGING ARTICLES FOR TRANSPORTATION; PACKAGING ARTICLES FOR TRANSPORTATION; PASSENGER TRANSPORT; PRODUCT CONTAINER CONSOLIDATION FOR TRANSPORTATION PURPOSES; PRODUCT PALLETIZATION SERVICES FOR TRANSPORTATION PURPOSES; PRODUCT REBOXING SERVICES FOR TRANSPORTATION PURPOSES; PROPELLER AIRPLANE TRANSPORT; PROVIDING OCEAN TRANSPORTATION, STORAGE AND DELIVERY SERVICES; RIVER TRANSPORT BY BOAT; RIVER TRANSPORT BY SHIP; SAILBOAT TRANSPORTATION SERVICES; SHIPPING



AND DELIVERY SERVICES, NAMELY, PICKUP, TRANSPORTATION, AND DELIVERY OF PACKAGES AND LETTERS BY VARIOUS MODES OF TRANSPORTATION; STORAGE, DISTRIBUTION, AND TRANSPORTATION OF LIQUEFIED PETROLEUM GAS; STREETCAR TRANSPORT; SUPPLY CHAIN LOGISTICS AND REVERSE LOGISTICS SERVICES, NAMELY, STORAGE, TRANSPORTATION AND DELIVERY OF DOCUMENTS, PACKAGES, RAW MATERIALS, AND OTHER FREIGHT FOR OTHERS BY AIR, RAIL, SHIP OR TRUCK; SUPPLY CHAIN LOGISTICS AND REVERSE LOGISTICS SERVICES, NAMELY, STORAGE, TRANSPORTATION AND DELIVERY OF GOODS FOR OTHERS BY AIR, RAIL, SHIP OR TRUCK; TANKER TRANSPORT; TAXI TRANSPORT; TAXI TRANSPORT FOR PEOPLE IN WHEELCHAIRS; TRANSPORT AND DELIVERY OF GOODS; TRANSPORT AND STORAGE OF GOODS; TRANSPORT BROKERAGE; TRANSPORT BY AIRCRAFT; TRANSPORT BY MAN-POWERED VEHICLES; TRANSPORT BY TWO-WHEELED MOTOR VEHICLES; TRANSPORT OF GOODS; TRANSPORT OF GOODS BY RAIL; TRANSPORT OF PASSENGERS; TRANSPORT OF PERSONS; TRANSPORT OF PERSONS AND GOODS; TRANSPORT OF TRAVELLERS; TRANSPORT OF VALUABLES; TRANSPORTATION AND DELIVERY SERVICES BY AIR, ROAD, RAIL AND SEA; TRANSPORTATION AND DELIVERY SERVICES, NAMELY, SAME DAY SHIPMENT SERVICES; TRANSPORTATION AND STORAGE OF FUELS; TRANSPORTATION AND STORAGE OF GOODS; TRANSPORTATION AND STORAGE OF GOODS IN REFRIGERATED CONDITIONS; TRANSPORTATION CONSULTING; TRANSPORTATION CONSULTING SERVICES; TRANSPORTATION INFORMATION; TRANSPORTATION OF GOODS; TRANSPORTATION OF GOODS, PASSENGERS AND TRAVELLERS BY AIR; TRANSPORTATION OF MEDICAL WASTE AND SPECIAL WASTE; TRANSPORTATION OF PASSENGERS AND GOODS BY RAIL; TRANSPORTATION OF PASSENGERS AND PASSENGERS' LUGGAGE; TRANSPORTATION RESERVATION SERVICES; TRUCK TRANSPORT; TURBOJET AIRPLANE TRANSPORT; VESSEL TRANSPORT (U.S. CLS. 100 AND 105).

FIRST USE 10-10-2008; IN COMMERCE 10-10-2008.

#### CLASS 40—MATERIAL TREATMENT

FOR HAZARDOUS WASTE MANAGEMENT; TECHNICAL CONSULTING IN THE FIELD OF SOLID AND HAZARDOUS WASTE MANAGEMENT (U.S. CLS. 100, 103 AND 106).

FIRST USE 10-10-2008; IN COMMERCE 10-10-2008.

KATHY DE JONGE, EXAMINING ATTORNEY

SN 85-151,349. TRADITION DEVELOPMENT COMPANY, LLC, PORT ST. LUCIE, FL. FILED 10-13-2010.

TRADITION CENTER FOR  
INNOVATION

THE MARK CONSISTS OF STANDARD CHARACTERS WITHOUT CLAIM TO ANY PARTICULAR FONT, STYLE, SIZE, OR COLOR.

NO CLAIM IS MADE TO THE EXCLUSIVE RIGHT TO USE "CENTER", APART FROM THE MARK AS SHOWN.

#### CLASS 35—ADVERTISING AND BUSINESS

FOR PROMOTING THE BUSINESS, COMMUNITY, MUNICIPAL AND CIVIC INTERESTS OF A MULTI-COUNTY AREA WITHIN FLORIDA; PROMOTING BUSINESS, RESIDENTIAL, COMMERCIAL GROWTH, AND ECONOMIC DEVELOPMENT OF A MULTI-COUNTY AREA WITHIN FLORIDA; PROVIDING DEMOGRAPHIC INFORMATION VIA A GLOBAL NETWORK ABOUT RESIDENTIAL AND COMMERCIAL GROWTH, ECONOMIC AND BUSINESS DEVELOPMENT SERVICES IN A MULTI-COUNTY AREA WITHIN FLORIDA (U.S. CLS. 100, 101 AND 102).

FIRST USE 5-3-2010; IN COMMERCE 5-3-2010.

#### CLASS 36—INSURANCE AND FINANCIAL

FOR REAL ESTATE SERVICES, NAMELY, REAL ESTATE BROKERAGE, ACQUISITION, RENTAL, LEASING, AND MANAGEMENT OF OFFICE, RESEARCH AND LABORATORY PROPERTIES (U.S. CLS. 100, 101 AND 102).

FIRST USE 5-3-2010; IN COMMERCE 5-3-2010.

JEAN IM, EXAMINING ATTORNEY

SN 85-151,368. TRADITION DEVELOPMENT COMPANY, LLC, PORT ST. LUCIE, FL. FILED 10-13-2010.



NO CLAIM IS MADE TO THE EXCLUSIVE RIGHT TO USE "CENTER", APART FROM THE MARK AS SHOWN.

THE COLOR(S) GREEN, RED, PURPLE, ORANGE, BLUE, YELLOW, AND WHITE IS/ARE CLAIMED AS A FEATURE OF THE MARK.

THE MARK CONSISTS OF THE WHIMSICAL OUTLINE OF A MAP OF THE STATE OF FLORIDA IN GREEN. ABOUT TWO-THIRDS OF THE WAY DOWN ON THE RIGHT HAND BOUNDARY OF THE WHIMSICAL MAP DESIGN IS A RED BALL WITH WHITE HIGHLIGHTING. AROUND THE RED BALL APPEAR TWO OVALS, WITH EACH HALF OF EACH OVAL APPEARING IN THE COLORS YELLOW, ORANGE, BLUE, AND PURPLE. THE RED BALL FORMS THE DOT IN THE LETTER "I" IN THE WORD "INNOVATION", WHICH APPEARS IN ALL CAPITAL LETTERS IN THE COLOR BLUE. CENTERED ABOVE THE WORD "INNOVATION" APPEAR THE WORDS "TRADITION CENTER FOR" IN ALL CAPITAL LETTERS AND IN THE COLOR GREEN.

#### CLASS 35—ADVERTISING AND BUSINESS

FOR PROMOTING THE BUSINESS, COMMUNITY, MUNICIPAL AND CIVIC INTERESTS OF A MULTI-COUNTY AREA WITHIN FLORIDA; PROMOTING BUSINESS, RESIDENTIAL, COMMERCIAL GROWTH, AND ECONOMIC DEVELOPMENT OF A MULTI-COUNTY AREA WITHIN FLORIDA; PROVIDING DEMOGRAPHIC INFORMATION VIA A GLOBAL NETWORK ABOUT RESIDENTIAL AND COMMERCIAL GROWTH, ECONOMIC AND BUSINESS DEVELOPMENT SERVICES IN A MULTI-COUNTY AREA WITHIN FLORIDA (U.S. CLS. 100, 101 AND 102).

FIRST USE 5-3-2010; IN COMMERCE 5-3-2010.

#### CLASS 36—INSURANCE AND FINANCIAL

FOR REAL ESTATE SERVICES, NAMELY, REAL ESTATE BROKERAGE, ACQUISITION, RENTAL, LEASING, AND MANAGEMENT OF OFFICE, RESEARCH AND LABORATORY PROPERTIES (U.S. CLS. 100, 101 AND 102).

FIRST USE 5-3-2010; IN COMMERCE 5-3-2010.

JEAN IM, EXAMINING ATTORNEY

SN 85-151,397. THE TRAVEL CHANNEL, L.L.C., CHEVY CHASE, MD. FILED 10-13-2010.

## GIRLS, GUNS & GATORS

THE MARK CONSISTS OF STANDARD CHARACTERS WITHOUT CLAIM TO ANY PARTICULAR FONT, STYLE, SIZE, OR COLOR.

### CLASS 9—ELECTRICAL AND SCIENTIFIC APPARATUS

FOR PRERECORDED VIDEO DISKS, AUDIO-VISUAL RECORDINGS, AND DVDS CONTAINING CONTENT IN THE NON-FICTION GENRE AND COVERING A WIDE RANGE OF SUBJECTS, NAMELY, MANAGING HUMAN RELATIONSHIPS, ENGAGING IN NEW EXPERIENCES AND FACING LIFE'S CHALLENGES SUCH AS RUNNING A SMALL BUSINESS (U.S. CLS. 21, 23, 26, 36 AND 38).

### CLASS 41—EDUCATION AND ENTERTAINMENT

FOR ENTERTAINMENT SERVICES IN THE NATURE OF A NON-FICTION TELEVISION SERIES IN THE NON-FICTION GENRE AND COVERING A WIDE RANGE OF SUBJECTS, NAMELY, MANAGING HUMAN RELATIONSHIPS, ENGAGING IN NEW EXPERIENCES AND FACING LIFE'S CHALLENGES SUCH AS RUNNING A SMALL BUSINESS; PROVIDING INFORMATION REGARDING SAME VIA A GLOBAL COMPUTER NETWORK (U.S. CLS. 100, 101 AND 107).  
KAREN SEVERSON, EXAMINING ATTORNEY

SN 85-151,419. ENDURANCE, LLC, ROCHESTER HILLS, MI. FILED 10-13-2010.



NO CLAIM IS MADE TO THE EXCLUSIVE RIGHT TO USE "WASTE REFINEMENT", APART FROM THE MARK AS SHOWN.

THE COLOR(S) ORANGE, WHITE, LIGHT GREY AND DARK GREY IS/ARE CLAIMED AS A FEATURE OF THE MARK.

THE MARK CONSISTS OF SIX ORANGE AND WHITE "W" SHAPED SYMBOLS ARRANGED IN THREE ROWS WITH THREE SYMBOLS ON THE TOP ROW, TWO SYMBOLS ON THE MIDDLE ROW AND ONE SYMBOL ON THE BOTTOM ROW, SHAPED CUMULATIVELY TO FORM AN UPSIDE-DOWN TRIANGLE SHAPED MARK, ADJACENT TO THE WORDING "WASTE REFINEMENT" WITH "WASTE" APPEARING IN LIGHT GREY AND "REFINEMENT" APPEARING IN DARK GREY.

### CLASS 11—ENVIRONMENTAL CONTROL APPARATUS

FOR WASTE PROCESSING MACHINES USING HEAT AND CHEMICAL BREAKDOWN PROCESSES (U.S. CLS. 13, 21, 23, 31 AND 34).

### CLASS 37—CONSTRUCTION AND REPAIR

FOR CONSULTING SERVICES FOR THE CONSTRUCTION OF WATER TREATMENT AND PURIFICATION PLANTS, SOLID WASTE TREATMENT PLANTS AND OTHER MUNICIPAL INFRASTRUCTURE FACILITIES; ENVIRONMENTAL REMEDIATION SERVICES, NAMELY, WASTE DISPOSAL (U.S. CLS. 100, 103 AND 106).

### CLASS 40—MATERIAL TREATMENT

FOR MATERIAL TREATMENT SERVICES IN CONNECTION WITH RECYCLING; WASTE-TO-ENERGY GENERATION SERVICES (U.S. CLS. 100, 103 AND 106).  
ERIN FALK, EXAMINING ATTORNEY

SN 85-151,527. MEDTECH PRODUCTS INC., IRVINGTON, NY. FILED 10-13-2010.

## EVERYTHING KIDS NEED AND NOTHING THEY DON'T

THE MARK CONSISTS OF STANDARD CHARACTERS WITHOUT CLAIM TO ANY PARTICULAR FONT, STYLE, SIZE, OR COLOR.

### CLASS 3—COSMETICS AND CLEANING PREPARATIONS

FOR NON-MEDICATED DIAPER RASH PREPARATIONS; NON-MEDICATED SKIN CREAM FOR TREATING ECZEMA AND LOTION FOR TREATING CRADLE CAP; NON-MEDICATED ANTI-ALLERGIC PREPARATION APPLIED AS A TOPICAL OINTMENT OR GEL (U.S. CLS. 1, 4, 6, 50, 51 AND 52).

### CLASS 5—PHARMACEUTICALS

FOR NASAL SPRAY AND DROP PREPARATIONS FOR THE RELIEF OF COLD SYMPTOMS; SALINE SOLUTIONS FOR RELIEF OF STUFFY OR DRY NOSES; STUFFY NOSE KITS CONSISTING OF SALINE SOLUTIONS AND NASAL ASPIRATORS; PREPARATIONS FOR TREATING COUGH AND COLD SYMPTOMS; DECONGESTANTS AND PREPARATIONS FOR COUGHS AND SORE THROATS; PREPARATIONS FOR RELIEF OF FEVER, ACHE AND PAINS; THROAT POPS FOR RELIEF OF SORE THROATS; CHEST RUB TO CLEAR CONGESTION, COUGH, AND REDUCE BODY INFLAMMATION; MEDICATED DIAPER RASH PREPARATIONS, AND GRIPE WATER PREPARATIONS FOR TREATMENT OF INTESTINAL GAS, STOMACH DISCOMFORT AND CONSTIPATION; ORAL PAIN RELIEF PREPARATIONS; EAR DROPS FOR DRYING WATER IN THE EARS AND RELIEVING EAR DISCOMFORT CAUSED BY WATER IN THE EARS; MEDICATED SKIN CREAM FOR TREATING ECZEMA AND MEDICATED LOTION FOR TREATING CRADLE CAP; AEROSOL ANESTHETIC PREPARATION FOR THE RELIEF OF SURFACE PAIN; SYRUP CONTAINING HONEY FOR SOOTHING SORE THROATS AND IRRITATION CAUSED BY COUGHING; MEDICATED ANTI-ALLERGIC PREPARATION APPLIED AS A TOPICAL OINTMENT OR GEL; TREATMENT FOR POISONS IN THE NATURE OF POISON ANTIDOTES (U.S. CLS. 6, 18, 44, 46, 51 AND 52).

MICHAEL ENGEL, EXAMINING ATTORNEY

SN 85-152,720. CT FINANCES, PARIS, FRANCE, FILED 10-14-2010.



NO CLAIM IS MADE TO THE EXCLUSIVE RIGHT TO USE "DESIGN SOLUTIONS", APART FROM THE MARK AS SHOWN.

THE COLOR(S) BLUE, BLACK AND WHITE IS/ARE CLAIMED AS A FEATURE OF THE MARK.

THE MARK CONSISTS OF THE TERM "CB'A" IN BLUE FOLLOWED BY THE WORD "DESIGN SOLUTIONS" IN BLACK; TO THE LEFT OF "CB'A" IS A VERTICAL BLACK LINE, AND FURTHER TO THE LEFT, A DESIGN OF A DIRIGIBLE IN BLUE WITH WHITE CLOUD DESIGN THEREON.

#### CLASS 35—ADVERTISING AND BUSINESS

FOR ADVERTISING, MARKETING AND PROMOTION SERVICES; BRANDING SERVICES, NAMELY, CONSULTING, DEVELOPMENT, MANAGEMENT AND MARKETING OF BRANDS FOR BUSINESSES; BUSINESS ADVISORY SERVICES IN THE FIELDS OF ARCHITECTURE AND INTERIOR DESIGN FOR RETAIL SPACES; PREPARATION OF CUSTOMIZED PROMOTIONAL AND MERCHANDISING MATERIALS FOR OTHERS (U.S. CLS. 100, 101 AND 102).

FIRST USE 1-0-2010; IN COMMERCE 1-0-2010.

#### CLASS 42—SCIENTIFIC AND COMPUTER SERVICES

FOR PACKAGING DESIGN FOR OTHERS; DESIGN AND CREATING WEB SITES FOR OTHERS (U.S. CLS. 100 AND 101).

FIRST USE 1-0-2010; IN COMMERCE 1-0-2010.  
ANDREW LEASER, EXAMINING ATTORNEY

SN 85-152,826. SHARK EATING DOG, LLC, DBA VINTAGE TROUBLE, LOS ANGELES, CA. FILED 10-14-2010.



THE COLOR(S) GOLD, BLACK AND BEIGE IS/ARE CLAIMED AS A FEATURE OF THE MARK.

THE MARK CONSISTS OF THE WORDS "VINTAGE TROUBLE" IN DARK BEIGE STYLIZED FONT, OUTLINED IN BLACK, AND WRITTEN AROUND A GOLD OUTLINE OF A SHIELD WITH THE LETTER "V" DIRECTLY ON TOP OF THE LETTER "T" IN THE MIDDLE OF THE SHIELD IN GOLD. ABOVE THE SHIELD IS THE GOLD OUTLINE OF A CROWN, AND THE SIDES OF THE SHIELD HAVE THE GOLD OUTLINE OF ORNAMENTAL FEATHERWORK. THE COLOR WHITE IS INTENDED TO SHOW BACKGROUND ONLY, AND IS NOT CLAIMED AS A FEATURE OF THE MARK.

#### CLASS 9—ELECTRICAL AND SCIENTIFIC APPARATUS

FOR DIGITAL MATERIALS, NAMELY, CDS, DVDS AND DOWNLOADABLE AUDIO FILES FEATURING MUSIC (U.S. CLS. 21, 23, 26, 36 AND 38).

FIRST USE 2-1-2010; IN COMMERCE 2-1-2010.

#### CLASS 41—EDUCATION AND ENTERTAINMENT

FOR ENTERTAINMENT SERVICES, NAMELY, PROVIDING INFORMATION ABOUT A RECORDING ARTIST VIA AN ONLINE NETWORK; ENTERTAINMENT SERVICES, NAMELY, PROVIDING NONDOWNLOADABLE PRERECORDED MUSIC, INFORMATION IN THE FIELD OF MUSIC, AND COMMENTARY AND ARTICLES ABOUT MUSIC, ALL ON-LINE VIA A GLOBAL COMPUTER NETWORK; LIVE PERFORMANCES BY A MUSICAL GROUP (U.S. CLS. 100, 101 AND 107).

FIRST USE 2-1-2010; IN COMMERCE 2-1-2010.  
JASON BLAIR, EXAMINING ATTORNEY

SN 85-153,289. VEDYAEV ARTEM, NOVOSIBIRSK, RUSSIAN FED., FILED 10-15-2010.



THE MARK CONSISTS OF WORD "CRAABS", WRITTEN IN ENGLISH IN UPPERCASE, WITH TWO A LETTERS STYLIZED AS A PAIR OF FLIP FLOPS (SLIPPERS) WITH STRAP.

#### CLASS 14—JEWELRY

FOR BRACELETS; INEXPENSIVE NON-JEWELRY WATCHES; JEWELRY; JEWELRY AND IMITATION JEWELRY; JEWELRY CHAINS; JEWELRY FOR THE HEAD; JEWELRY TO BE AFFIXED TO BIKINIS; JEWELRY, NAMELY, ARM CUFFS; PLASTIC BRACELETS IN THE NATURE OF JEWELRY; RINGS; STAINLESS STEEL JEWELRY BRACELETS; WATCHES AND JEWELRY; WOMEN'S JEWELRY (U.S. CLS. 2, 27, 28 AND 50).

#### CLASS 18—LEATHER GOODS

FOR BACKPACKS, BOOK BAGS, SPORTS BAGS, BUM BAGS, WALLETS AND HANDBAGS; BEACH BAGS; CANVAS SHOPPING BAGS (U.S. CLS. 1, 2, 3, 22 AND 41).

#### CLASS 25—CLOTHING

FOR (BASED ON USE IN COMMERCE) BEACH FOOTWEAR; FLIP FLOPS; FOOTWEAR; FOOTWEAR FOR MEN; FOOTWEAR FOR MEN AND WOMEN; FOOTWEAR FOR WOMEN; FOOTWEAR NOT FOR SPORTS; FOOTWEAR, NAMELY, RUBBERS; JAPANESE SPLIT-TOED WORK FOOTWEAR (JIKATABI); THONGS(-BASED ON INTENT TO USE) ATHLETIC FOOTWEAR; CAPS; DRESSES THAT MAY ALSO BE USED AS TOWELS; EYESHADES; FOOTWEAR, NAMELY, WORK BOOTS; HEAD WEAR; HEADWEAR; JACKETS; JERSEYS; SANDALS; SHORTS; SKI WEAR; SNEAKERS; SOCKS; SOLES FOR FOOTWEAR; T-SHIRTS; TIPS FOR FOOTWEAR; WATERPROOF FOOTWEAR (U.S. CLS. 22 AND 39).

FIRST USE 1-1-2010; IN COMMERCE 10-1-2010.  
MATTHEW KLINE, EXAMINING ATTORNEY

SN 85-153,376. CAPITAL RELOCATION SERVICES, LLC,  
STERLING, VA. FILED 10-15-2010.

# CapRelo

THE MARK CONSISTS OF STANDARD CHARACTERS WITHOUT CLAIM TO ANY PARTICULAR FONT, STYLE, SIZE, OR COLOR.

### CLASS 35—ADVERTISING AND BUSINESS

FOR BUSINESS SERVICES, NAMELY, FORMULATION OF BEST PRACTICES FOR PLANNING AND IMPLEMENTING MOVES OF HOMES AND OFFICES THROUGH THE USE OF COST ANALYSIS AND BUSINESS STUDIES (U.S. CLS. 100, 101 AND 102).

### CLASS 36—INSURANCE AND FINANCIAL

FOR FINANCIAL INVESTMENT IN THE FIELD OF REAL ESTATE (U.S. CLS. 100, 101 AND 102).  
DAVID YONTEF, EXAMINING ATTORNEY

SN 85-153,405. QUBO VENTURES, LLC, WEST PALM BEACH, FL. FILED 10-15-2010.



OWNER OF U.S. REG. NOS. 3,255,844 AND 3,260,791.  
NO CLAIM IS MADE TO THE EXCLUSIVE RIGHT TO USE "CHANNEL", APART FROM THE MARK AS SHOWN.  
THE COLOR(S) BLACK, WHITE, YELLOW, BLUE, AQUA IS/ARE CLAIMED AS A FEATURE OF THE MARK.

THE MARK CONSISTS OF "NIGHT OWL", WITH A STYLIZED OWL ON TOP OF THE WORD "OWL" ABOVE A STYLIZED CUBE DESIGN ABOVE THE WORD "QUBO" ABOVE "CHANNEL". "NIGHT OWL" IS AQUA WITH BLACK OUTLINES. THE OWL HAS A BLACK BODY WITH YELLOW AND WHITE EYES AND BLACK PUPILS. THERE IS A BLUE PANEL AND A SMALLER AQUA PANEL ON THE OWL'S CHEST. THE CUBE FEATURES TWO BLUE SIDES, FADING TO WHITE SIDE WITH WHITE STARS. THE REST IS BLACK. "QUBO" IS LARGER THAN "CHANNEL". BOTH WORDS ARE BLACK.

### CLASS 38—COMMUNICATION

FOR CABLE TELEVISION BROADCASTING; TELEVISION BROADCASTING; VIDEO BROADCASTING (U.S. CLS. 100, 101 AND 104).  
FIRST USE 9-27-2010; IN COMMERCE 9-27-2010.

### CLASS 41—EDUCATION AND ENTERTAINMENT

FOR DISTRIBUTION OF TELEVISION PROGRAMMING TO CABLE TELEVISION SYSTEMS; ENTERTAINMENT IN THE NATURE OF ON-GOING TELEVISION PROGRAMS IN THE FIELD OF SPORTS, MOVIES, WEATHER, COMEDY, DRAMA, CHILDREN'S PROGRAMMING, CARTOONS AND VARIETY SHOWS (U.S. CLS. 100, 101 AND 107).

FIRST USE 9-27-2010; IN COMMERCE 9-27-2010.  
JOHN E. MICHOS, EXAMINING ATTORNEY

SN 85-153,408. CAPITAL RELOCATION SERVICES, LLC,  
STERLING, VA. FILED 10-15-2010.



THE COLOR(S) GRAY AND ORANGE IS/ARE CLAIMED AS A FEATURE OF THE MARK.

THE MARK CONSISTS OF THE WORD "CAPRELO" IN STYLIZED FONT WHEREBY THE LETTERS "CAP" APPEAR IN GRAY AND THE LETTERS "RELO" APPEAR IN ORANGE BELOW A STYLIZED RENDERING OF A GRAY CIRCLE WITHIN AN ORANGE GEOMETRIC SHAPE COMPRISED OF THREE LINES WITH ARROWS THAT RESEMBLE A SQUARE.

### CLASS 35—ADVERTISING AND BUSINESS

FOR BUSINESS SERVICES, NAMELY, FORMULATION OF BEST PRACTICES FOR PLANNING AND IMPLEMENTING MOVES OF HOMES AND OFFICES THROUGH THE USE OF COST ANALYSIS AND BUSINESS STUDIES (U.S. CLS. 100, 101 AND 102).

### CLASS 36—INSURANCE AND FINANCIAL

FOR FINANCIAL INVESTMENT IN THE FIELD OF REAL ESTATE (U.S. CLS. 100, 101 AND 102).  
DAVID YONTEF, EXAMINING ATTORNEY

SN 85-153,465. SPIDERWOOD STUDIOS, LLC, DBA SPIDERWOOD STUDIOS, AUSTIN, TX. FILED 10-15-2010.



NO CLAIM IS MADE TO THE EXCLUSIVE RIGHT TO USE "NEWS NETWORK", APART FROM THE MARK AS SHOWN.

THE COLOR(S) ORANGE, WHITE, BLUE, AND BLACK IS/ARE CLAIMED AS A FEATURE OF THE MARK.

THE MARK CONSISTS OF "GREATER NEWS NETWORK" WHERE THE FIRST LETTER OF EACH WORD IS BOLD ORANGE IN BLOCK LETTERS WITH A WHITE SHORT STRIPE IN EACH LETTER. THE REST OF THE LETTERS IN EACH WORD ARE LOWER CASE BLACK WITH ORANGE OUTLINE, AND UNDERLINED IN ORANGE. THE WORDS "GREATER NEWS NETWORK" ARE STACKED AT AN ANGLE DOWN FROM LEFT TO RIGHT. THERE IS A BLUE AND WHITE EARTH IN THE BACKGROUND STRETCHED AT THE SAME ANGLE DOWN FROM LEFT TO RIGHT, JUST RIGHT OF THE WORDS.

#### CLASS 35—ADVERTISING AND BUSINESS

FOR ADVERTISING AND PUBLICITY SERVICES, NAMELY, PROMOTING THE GOODS, SERVICES, BRAND IDENTITY AND COMMERCIAL INFORMATION AND NEWS OF THIRD PARTIES THROUGH PRINT, AUDIO, VIDEO, DIGITAL AND ON-LINE MEDIUM (U.S. CLS. 100, 101 AND 102).

#### CLASS 41—EDUCATION AND ENTERTAINMENT

FOR ENTERTAINMENT IN THE NATURE OF VISUAL AND AUDIO PERFORMANCES, AND MUSICAL, VARIETY, NEWS AND COMEDY SHOWS; PROVIDING INFORMATION, NEWS AND COMMENTARY IN THE FIELD OF ENTERTAINMENT (U.S. CLS. 100, 101 AND 107).

JOHN GARTNER, EXAMINING ATTORNEY

---

SN 85-153,538. A GIRL'S GOTTA SPA, INC., PATCHOGUE, NY. FILED 10-15-2010.

### SERIOUSLY SPOILED SALON AND SPA

THE MARK CONSISTS OF STANDARD CHARACTERS WITHOUT CLAIM TO ANY PARTICULAR FONT, STYLE, SIZE, OR COLOR.

NO CLAIM IS MADE TO THE EXCLUSIVE RIGHT TO USE "SALON AND SPA", APART FROM THE MARK AS SHOWN.

#### CLASS 35—ADVERTISING AND BUSINESS

FOR FRANCHISE SERVICES, NAMELY, OFFERING BUSINESS MANAGEMENT ASSISTANCE IN THE ESTABLISHMENT AND OPERATION OF BEAUTY SALONS AND SPAS (U.S. CLS. 100, 101 AND 102).

#### CLASS 41—EDUCATION AND ENTERTAINMENT

FOR CHILDREN'S PARTY AND ENTERTAINMENT SERVICES, NAMELY, PLANNING, COORDINATION AND PRODUCTION OF CHILDREN'S PARTIES (U.S. CLS. 100, 101 AND 107).

#### CLASS 44—MEDICAL, BEAUTY AND AGRICULTURAL SERVICES

FOR SPA SERVICES, NAMELY, PROVIDING FACIAL, HAIR, SKIN AND BODY TREATMENTS AND MANICURE AND PEDICURE SERVICES; BEAUTY SALON SERVICES, NAMELY, HAIRSTYLING, HAIRCUTTING AND MAKE-UP APPLICATION SERVICES (U.S. CLS. 100 AND 101).

KATHLEEN M. VANSTON, EXAMINING ATTORNEY

SN 85-153,684. BOSTON SCIENTIFIC NEUROMODULATION CORPORATION, VALENCIA, CA. FILED 10-15-2010.

### PRECISION SPECTRA

THE MARK CONSISTS OF STANDARD CHARACTERS WITHOUT CLAIM TO ANY PARTICULAR FONT, STYLE, SIZE, OR COLOR.

OWNER OF U.S. REG. NOS. 2,883,258, 3,173,321 AND 3,232,473.

#### CLASS 9—ELECTRICAL AND SCIENTIFIC APPARATUS

FOR BATTERY CHARGERS; ELECTRIC CABLES; CLINICIAN COMPUTER PROGRAMS USED IN PROGRAMMING, MONITORING, AND CONTROLLING AN IMPLANTABLE PULSE GENERATOR; HANDHELD REMOTE CONTROL UNITS FOR CONTROLLING THE IMPLANTABLE PULSE GENERATOR; PROGRAMMING SOFTWARE FOR THE CLINICIAN PROGRAMMERS AND/OR HANDHELD REMOTE CONTROL UNITS, NAMELY, FOR PROGRAMMING THE STIMULATION PARAMETERS USED BY THE IMPLANTABLE PULSE GENERATOR (U.S. CLS. 21, 23, 26, 36 AND 38).

#### CLASS 10—MEDICAL APPARATUS

FOR IMPLANTABLE NEUROSTIMULATION SYSTEMS, NAMELY, AN IMPLANTABLE PULSE GENERATOR HAVING A RECHARGEABLE BATTERY FOR PROVIDING CONTROLLED ELECTRICAL STIMULATION PULSES, LEADS AND ELECTRODE ARRAYS USED WITH THE IMPLANTABLE PULSE GENERATOR, AND ACCESSORIES USED THEREWITH, NAMELY, AN EXTERNAL TRIAL STIMULATOR, A HANDHELD PROGRAMMER FOR USE WITH THE IMPLANTABLE PULSE GENERATOR, A BATTERY CHARGER FOR RECHARGING THE RECHARGEABLE BATTERY IN THE IMPLANTABLE PULSE GENERATOR, A CLINICIAN PROGRAMMER FOR USE WITH THE HANDHELD PROGRAMMER, THE IMPLANTABLE PULSE GENERATOR AND/OR TRIAL STIMULATOR (U.S. CLS. 26, 39 AND 44).

JAMES STEIN, EXAMINING ATTORNEY

---

SN 85-153,919. MAURICES INCORPORATED, DULUTH, MN. FILED 10-15-2010.

### MAIN STREET MODEL SEARCH

THE MARK CONSISTS OF STANDARD CHARACTERS WITHOUT CLAIM TO ANY PARTICULAR FONT, STYLE, SIZE, OR COLOR.

NO CLAIM IS MADE TO THE EXCLUSIVE RIGHT TO USE "MODEL SEARCH", APART FROM THE MARK AS SHOWN.

#### CLASS 35—ADVERTISING AND BUSINESS

FOR RETAIL CLOTHING AND APPAREL STORE SERVICES; ONLINE RETAIL CLOTHING AND APPAREL STORE SERVICES; AND ARRANGING AND CONDUCTING A MODEL SEARCH CONTEST TO PROMOTE THE SALE OF CLOTHING AND ACCESSORIES (U.S. CLS. 100, 101 AND 102).

**CLASS 41—EDUCATION AND ENTERTAINMENT**

FOR ENTERTAINMENT SERVICES, NAMELY, A MODEL SEARCH CONTEST (U.S. CLS. 100, 101 AND 107).

BILL DAWE, EXAMINING ATTORNEY

SN 85-153,928. MAURICES INCORPORATED, DULUTH, MN. FILED 10-15-2010.

**FOR THE RUNWAY OF LIFE**

THE MARK CONSISTS OF STANDARD CHARACTERS WITHOUT CLAIM TO ANY PARTICULAR FONT, STYLE, SIZE, OR COLOR.

**CLASS 35—ADVERTISING AND BUSINESS**

FOR RETAIL CLOTHING AND APPAREL STORE SERVICES; ONLINE RETAIL CLOTHING AND APPAREL STORE SERVICES; AND ARRANGING AND CONDUCTING A MODEL SEARCH CONTEST TO PROMOTE THE SALE OF CLOTHING AND ACCESSORIES (U.S. CLS. 100, 101 AND 102).

**CLASS 41—EDUCATION AND ENTERTAINMENT**

FOR ENTERTAINMENT SERVICES, NAMELY, A MODEL SEARCH CONTEST (U.S. CLS. 100, 101 AND 107).

BILL DAWE, EXAMINING ATTORNEY

SN 85-153,978. EXECU\*SYSTEMS, INC., PHOENIX, AZ. FILED 10-15-2010.

**CLASS 35—ADVERTISING AND BUSINESS**

FOR COOPERATIVE ADVERTISING AND MARKETING SERVICES; OFFERING BUSINESS MANAGEMENT ASSISTANCE IN THE ESTABLISHMENT AND OPERATION OF REAL ESTATE AGENCIES (U.S. CLS. 100, 101 AND 102).

**CLASS 36—INSURANCE AND FINANCIAL**

FOR REAL ESTATE INFORMATION AND BROKERAGE SERVICES (U.S. CLS. 100, 101 AND 102).

MARIA-VICTORIA SUAREZ, EXAMINING ATTORNEY

SN 85-154,012. PARKSHORE WEALTH MANAGEMENT, ROSEVILLE, CA. FILED 10-15-2010.



NO CLAIM IS MADE TO THE EXCLUSIVE RIGHT TO USE "WEALTH MANAGEMENT", APART FROM THE MARK AS SHOWN.

THE COLOR(S) BLUE AND GOLD IS/ARE CLAIMED AS A FEATURE OF THE MARK.

THE MARK CONSISTS OF A DARK BLUE RECTANGULAR BOX WITH A GOLD BORDER. THE GOLD BORDER CONSISTS OF FOUR SMALLER SQUARES IN EACH CORNER AND ONE RECTANGLE CONNECTING EACH CORNER. "PARKSHORE WEALTH MANAGEMENT" IN GOLD IS WRITTEN IN THE CENTER OF THE RECTANGLE. "PARKSHORE WEALTH MANAGEMENT" IS WRITTEN USING CHELSEA STUDIO FONT.

**CLASS 35—ADVERTISING AND BUSINESS**

FOR INCOME TAX CONSULTATION; INCOME TAX PREPARATION; TAX ADVISORY SERVICES; TAX AND TAXATION PLANNING, ADVICE, INFORMATION AND CONSULTANCY SERVICES; TAX PREPARATION (U.S. CLS. 100, 101 AND 102).

FIRST USE 9-1-2010; IN COMMERCE 9-1-2010.

**CLASS 36—INSURANCE AND FINANCIAL**

FOR ESTATE PLANNING; FINANCIAL PLANNING; FINANCIAL PLANNING AND INVESTMENT ADVISORY SERVICES; FINANCIAL PLANNING FOR RETIREMENT; FINANCIAL PLANNING SERVICES, NAMELY, DEVELOPING AND MANAGING CHARITABLE GIVING PROGRAMS ON BEHALF OF WEALTHY INDIVIDUALS OR FAMILIES; FINANCIAL PLANNING, NAMELY, THE CREATION OF PERSONALIZED STRATEGIES TO ACHIEVE FINANCIAL INDEPENDENCE; FINANCIAL PORTFOLIO ANALYSIS SERVICES; FINANCIAL PORTFOLIO MANAGEMENT; FINANCIAL SERVICES IN THE NATURE OF AN INVESTMENT SECURITY; FINANCIAL SERVICES, NAMELY, A TOTAL PORTFOLIO OFFERING FOR HIGH NET WORTH CLIENTS CONSISTING OF BOTH SEPARATE ACCOUNTS AND MUTUAL FUNDS FOR EQUITY AND FIXED INCOME INVESTMENTS; FINANCIAL SERVICES, NAMELY, ASSISTING OTHERS WITH THE COMPLETION OF FINANCIAL TRANSACTIONS FOR STOCKS, BONDS, SECURITIES AND EQUITIES; FINANCIAL SERVICES, NAMELY, COORDINATION, WITHIN A SINGLE ACCOUNT, OF AN INVESTMENT PORTFOLIO'S MAINTENANCE, TRADING, REBALANCING, AND TAX MANAGEMENT NEEDS; FINANCIAL SERVICES, NAMELY, INVESTMENT ADVICE, INVESTMENT MANAGEMENT, INVESTMENT CONSULTATION AND INVESTMENT OF FUNDS FOR OTHERS, INCLUDING PRIVATE AND PUBLIC EQUITY AND DEBT INVESTMENT SERVICES; FINANCIAL SERVICES, NAMELY, WEALTH MANAGEMENT SERVICES; INDIVIDUAL RETIREMENT ACCOUNT SERVICES; INVESTMENT ADVICE; MANAGEMENT OF PORTFOLIOS COMPRISING SECURITIES; MANAGEMENT OF SECURITIES PORTFOLIOS; MUTUAL FUND INVESTMENT; PROVIDING FINANCIAL SERVICES WITH RESPECT TO SECURITIES AND OTHER FINANCIAL INSTRUMENTS AND PRODUCTS, NAMELY, MONEY MANAGEMENT SERVICES; PROVIDING FINANCIAL SERVICES WITH RESPECT TO SECURITIES AND OTHER FINANCIAL INSTRUMENTS AND PRODUCTS, NAMELY, TRADING OF AND INVESTMENTS IN SECURITIES AND FINANCIAL INSTRUMENTS AND PRODUCTS FOR OTHERS; PROVIDING INFORMATION AND ADVICE IN THE FIELD OF FINANCE, FINANCIAL INVESTMENTS, FINANCIAL VALUATIONS, AND THE FINANCIAL ASPECTS OF RETIREMENT (U.S. CLS. 100, 101 AND 102).

FIRST USE 9-1-2010; IN COMMERCE 9-1-2010.

DARRYL SPRUILL, EXAMINING ATTORNEY

SN 85-154,123. PROCESS DISPLAYS CO., MINNEAPOLIS, MN. FILED 10-15-2010.

---

SN 85-154,122. DR. SEUSS ENTERPRISES, L.P., LA JOLLA, CA. FILED 10-15-2010.



OWNER OF U.S. REG. NOS. 3,205,387 AND 3,903,613.  
THE MARK CONSISTS OF THE NUMBER "50" AND A FISH JUMPING THROUGH THE NUMBER "0" AND THE WORDS "YEARS OF FUN" UNDER THE "0".

**CLASS 16—PAPER GOODS AND PRINTED MATTER**

FOR PAPER BOOKMARKS, POSTERS, PAPER CROWNS (U.S. CLS. 2, 5, 22, 23, 29, 37, 38 AND 50).  
FIRST USE 6-8-2010; IN COMMERCE 6-8-2010.

**CLASS 18—LEATHER GOODS**

FOR TOTE BAGS (U.S. CLS. 1, 2, 3, 22 AND 41).  
FIRST USE 6-8-2010; IN COMMERCE 6-8-2010.

**CLASS 21—HOUSEWARES AND GLASS**

FOR METAL LUNCH BOX (U.S. CLS. 2, 13, 23, 29, 30, 33, 40 AND 50).  
FIRST USE 6-8-2010; IN COMMERCE 6-8-2010.

**CLASS 41—EDUCATION AND ENTERTAINMENT**

FOR EDUCATIONAL SERVICES, NAMELY, INSTRUCTION FOR CHILDREN IN THE FIELD OF OCEANOGRAPHY; ENTERTAINMENT SERVICES, NAMELY, FACE PAINTING, ARTS AND CRAFTS FOR CHILDREN (U.S. CLS. 100, 101 AND 107).  
FIRST USE 6-8-2010; IN COMMERCE 6-8-2010.  
ROSELLE HERRERA, EXAMINING ATTORNEY



THE MARK CONSISTS OF A STYLIZED CAPITAL LETTER "P" AND LOWER CASE LETTER "D", ARRANGED VERTICALLY AND ENCLOSED WITHIN A CIRCLE.

**CLASS 35—ADVERTISING AND BUSINESS**

FOR ADVERTISING SERVICES PROVIDED FOR THIRD PARTIES, NAMELY, THE DESIGN AND CREATION OF TEMPORARY AND PERMANENT POINT-OF-SALE RETAIL DISPLAYS, SEASONAL SIGNAGE, AND IN-STORE FIXTURES; DESIGNING OF ADVERTISING MATERIALS FOR OTHERS, NAMELY, TEMPORARY AND PERMANENT POINT-OF-SALE RETAIL DISPLAYS, SEASONAL SIGNAGE AND IN-STORE FIXTURES (U.S. CLS. 100, 101 AND 102).  
FIRST USE 12-15-2003; IN COMMERCE 12-15-2003.

**CLASS 40—MATERIAL TREATMENT**

FOR PRINTING TEMPORARY AND PERMANENT POINT-OF-SALE RETAIL DISPLAYS, SEASONAL SIGNAGE, AND IN-STORE FIXTURES; CUSTOM FABRICATION AND PRODUCTION OF TEMPORARY AND PERMANENT POINT-OF-SALE RETAIL DISPLAYS, SEASONAL SIGNAGE, AND IN-STORE FIXTURES (U.S. CLS. 100, 103 AND 106).  
FIRST USE 12-15-2003; IN COMMERCE 12-15-2003.  
AMEEN IMAM, EXAMINING ATTORNEY

---

SN 85-154,146. PROCESS DISPLAYS CO., MINNEAPOLIS, MN. FILED 10-15-2010.



**DO MORE INSTORE**

THE MARK CONSISTS OF A STYLIZED CAPITAL LETTER "P" AND LOWER CASE LETTER "D" ARRANGED VERTICALLY AND ENCLOSED WITHIN A CIRCLE DIRECTLY ABOVE THE PHRASE "DO MORE INSTORE".

**CLASS 35—ADVERTISING AND BUSINESS**

FOR ADVERTISING SERVICES PROVIDED FOR THIRD PARTIES, NAMELY, THE DESIGN AND CREATION OF TEMPORARY AND PERMANENT POINT-OF-SALE RETAIL DISPLAYS, SEASONAL SIGNAGE, AND IN-STORE FIXTURES; DESIGNING OF ADVERTISING MATERIALS FOR OTHERS, NAMELY, TEMPORARY AND PERMANENT POINT-OF-SALE RETAIL DISPLAYS, SEASONAL SIGNAGE AND IN-STORE FIXTURES (U.S. CLS. 100, 101 AND 102).

FIRST USE 10-13-2010; IN COMMERCE 10-13-2010.

**CLASS 40—MATERIAL TREATMENT**

FOR PRINTING TEMPORARY AND PERMANENT POINT-OF-SALE RETAIL DISPLAYS, SEASONAL SIGNAGE, AND IN-STORE FIXTURES; CUSTOM FABRICATION AND PRODUCTION OF TEMPORARY AND PERMANENT POINT-OF-SALE RETAIL DISPLAYS, SEASONAL SIGNAGE, AND IN-STORE FIXTURES (U.S. CLS. 100, 103 AND 106).

FIRST USE 10-13-2010; IN COMMERCE 10-13-2010.

AMEEN IMAM, EXAMINING ATTORNEY

SN 85-154,500, LOCKSHAW, JAMES, PASO ROBLES, CA, FILED 10-17-2010.

**CIRCLE CYCLE**

THE MARK CONSISTS OF STANDARD CHARACTERS WITHOUT CLAIM TO ANY PARTICULAR FONT, STYLE, SIZE, OR COLOR.

NO CLAIM IS MADE TO THE EXCLUSIVE RIGHT TO USE "CYCLE", APART FROM THE MARK AS SHOWN.

**CLASS 7—MACHINERY**

FOR COMPRESSORS FOR MACHINES; INTERNAL COMBUSTION ENGINES FOR MACHINE OPERATION AND REPLACEMENT PARTS THEREFOR; INTERNAL COMBUSTION ENGINES FOR POWER GENERATION, OTHER THAN FOR LAND VEHICLES; INTERNAL COMBUSTION ENGINES FOR BOATS (U.S. CLS. 13, 19, 21, 23, 31, 34 AND 35).

**CLASS 12—VEHICLES**

FOR INTERNAL COMBUSTION ENGINES FOR LAND VEHICLES (U.S. CLS. 19, 21, 23, 31, 35 AND 44).

JIM RINGLE, EXAMINING ATTORNEY

SN 85-154,533, HILGER, PHILIPPE H., VANCOUVER, BC, CANADA, FILED 10-17-2010.



THE COLOR(S) PURPLE, GREEN, RED AND BLACK IS/ARE CLAIMED AS A FEATURE OF THE MARK.

THE MARK CONSISTS OF A STYLIZED WRITING OF THE WORD "MUSXPAND" OUTLINED IN BLACK WITH ALL LOWERCASE LETTERS EXCEPT THE LETTER "X" IN UPPERCASE, WITH A COLOR GRADIENT FROM PURPLE IN THE TOP LEFT CORNER OF THE DESIGN TO RED IN THE BOTTOM RIGHT CORNER, THROUGH GREEN IN THE CENTRAL PART.

**CLASS 9—ELECTRICAL AND SCIENTIFIC APPARATUS**

FOR AUDIO AND VIDEO RECORDINGS FEATURING MUSIC AND ARTISTIC PERFORMANCES; COMPACT DISCS FEATURING MUSIC; COMPUTER SOFTWARE FEATURING MUSICAL SOUND RECORDINGS AND MUSICAL VIDEO RECORDINGS; COMPUTER SOFTWARE FOR PROCESSING DIGITAL MUSIC FILES; DIGITAL MUSIC DOWNLOADABLE FROM THE INTERNET; DIGITAL MUSIC SYSTEM THAT SYNCHRONIZES DIGITAL MUSIC FILES STORED ON A HOME UNIT AND A CAR UNIT; DOWNLOADABLE MP3 FILES, MP3 RECORDINGS, ON-LINE DISCUSSION BOARDS, WEBCASTS, WEBINARS AND PODCASTS FEATURING MUSIC, AUDIO BOOKS IN THE FIELD OF MUSIC, AND NEWS BROADCASTS; DOWNLOADABLE MUSICAL SOUND RECORDINGS; DOWNLOADABLE RING TONES, GRAPHICS AND MUSIC VIA A GLOBAL COMPUTER NETWORK AND WIRELESS DEVICES; DOWNLOADABLE VIDEO RECORDINGS FEATURING MUSIC; MUSICAL SOUND RECORDINGS; MUSICAL VIDEO RECORDINGS; SERIES OF MUSICAL SOUND RECORDINGS; SOUND RECORDINGS FEATURING MUSIC; VIDEO RECORDINGS FEATURING MUSIC; VISUAL RECORDINGS AND AUDIOVISUAL RECORDINGS FEATURING MUSIC AND ANIMATION (U.S. CLS. 21, 23, 26, 36 AND 38).

**CLASS 35—ADVERTISING AND BUSINESS**

FOR BUSINESS CONSULTING, BUSINESS MANAGEMENT AND PROVIDING INFORMATION IN THE MUSIC BUSINESS FIELD; ON-LINE RETAIL STORE SERVICES FEATURING DOWNLOADABLE PRE-RECORDED MUSIC AND VIDEO; ON-LINE WHOLESALE AND RETAIL STORE SERVICES FEATURING DOWNLOADABLE SOUND, MUSIC, IMAGE, VIDEO AND GAME FILES; PERSONAL MANAGEMENT SERVICES FOR MUSICAL PERFORMERS; RETAIL MUSIC AND RECORD STORES (U.S. CLS. 100, 101 AND 102).

**CLASS 41—EDUCATION AND ENTERTAINMENT**

FOR ENTERTAINMENT IN THE NATURE OF VISUAL AND AUDIO PERFORMANCES BY MUSICAL ARTISTS AND BANDS; ENTERTAINMENT INFORMATION SERVICES, NAMELY, PROVIDING INFORMATION AND NEWS RELEASES ABOUT A MUSICAL ARTIST; ENTERTAINMENT SERVICES, NAMELY, PROVIDING NONDOWNLOADABLE PRE-RECORDED MUSIC, INFORMATION IN THE FIELD OF MUSIC, AND COMMENTARY AND ARTICLES ABOUT MUSIC, ALL ON-LINE VIA A GLOBAL COMPUTER NETWORK; ENTERTAINMENT SERVICES, NAMELY, PROVIDING ON-LINE REVIEWS OF MUSIC; ENTERTAINMENT, NAMELY, LIVE PERFORMANCES BY MUSICAL BANDS; ORGANIZATION OF EXHIBITIONS FOR MUSICAL ENTERTAINMENT; PLANNING ARRANGEMENT OF SHOWING MOVIES, SHOWS, PLAYS OR MUSICAL PERFORMANCES; PROVIDING A WEBSITE FEATURING INFORMATION IN THE FIELD OF MUSIC AND ENTERTAINMENT; PROVIDING A WEBSITE FOR ENTERTAINMENT PURPOSES WHERE USERS CAN VIEW AND POST PICTURES, VIDEOS AND RECORDINGS FEATURING MUSICAL ARTISTS AND BANDS; PROVIDING AN INTERNET WEBSITE PORTAL IN THE FIELD OF MUSIC; PROVISION OF INFORMATION RELATING TO MUSIC (U.S. CLS. 100, 101 AND 107).



**CLASS 42—SCIENTIFIC AND COMPUTER SERVICES**

FOR COMPUTER SERVICES, NAMELY, DIGITAL FORMATTING AND COMPRESSION OF MUSIC AND IMAGES, NAMELY, PROCESSING OF DIGITAL MUSIC AND VIDEO IMAGES INTO DOWNLOADABLE PRODUCTS; COMPUTER SERVICES, NAMELY, HOSTING ON-LINE WEB FACILITIES FOR OTHERS TO SHOW-CASE SONGWRITING AND MUSICAL TALENTS AND FOR FACILITATING AND CONDUCTING ONLINE CONNECTIONS, COLLABORATIONS, AND INTERACTIVE DISCUSSIONS ABOUT SONGWRITING AND MUSIC; PROVIDING A WEBSITE ALLOWING USERS TO UPLOAD AND DOWNLOAD MUSIC; PROVIDING A WEBSITE FEATURING TECHNOLOGY THAT ENABLES USERS TO UPLOAD AND DOWNLOAD MUSIC RELATED RECORDINGS (U.S. CLS. 100 AND 101).  
ARETHA SOMERVILLE, EXAMINING ATTORNEY

---

SN 85-154,589. CORTESE, ANTHONY, OCONOMOWOC, WI.  
FILED 10-18-2010.

**ICEFISH ICED TEA**

THE MARK CONSISTS OF STANDARD CHARACTERS WITHOUT CLAIM TO ANY PARTICULAR FONT, STYLE, SIZE, OR COLOR.

NO CLAIM IS MADE TO THE EXCLUSIVE RIGHT TO USE "ICED TEA", APART FROM THE MARK AS SHOWN.

**CLASS 30—STAPLE FOODS**

FOR TEA BASED BEVERAGES, NAMELY, ICED TEA (U.S. CL. 46).

**CLASS 32—LIGHT BEVERAGES**

FOR LEMONADES (U.S. CLS. 45, 46 AND 48).  
BRENDAN MCCAULEY, EXAMINING ATTORNEY

---

SN 85-154,860. NIADYNE, INC., RESEARCH TRIANGLE PARK, NC. FILED 10-18-2010.

**NIASPHERES**

THE MARK CONSISTS OF STANDARD CHARACTERS WITHOUT CLAIM TO ANY PARTICULAR FONT, STYLE, SIZE, OR COLOR.

OWNER OF U.S. REG. NOS. 3,471,879, 3,471,881 AND OTHERS.

**CLASS 3—COSMETICS AND CLEANING PREPARATIONS**

FOR NON-MEDICATED SKIN CARE PREPARATIONS FOR THE TREATMENT AND PREVENTION OF PHOTO DAMAGE AND HYPER PIGMENTATION IN SKIN; NON-MEDICATED WRINKLE REMOVING SKIN PREPARATIONS; NON-MEDICATED SKIN PREPARATIONS FOR SMOOTHING, SOFTENING, MOISTURIZING, FIRING AND ENHANCING TONE OF SKIN; NON-MEDICATED SKIN CREAMS; NON-MEDICATED SKIN LOTIONS; NON-MEDICATED SKIN CLEANSERS; NON-MEDICATED SKIN EXFOLIATING PREPARATIONS; NON-MEDICATED SOAPS; NON-MEDICATED BODY OILS; NON-MEDICATED BATH GELS, SHOWER GELS AND BODY WASHES; NON-MEDICATED PRE-MOISTENED COSMETIC TISSUES, TOWELETTES AND WIPES; NON-MEDICATED EYE CREAMS (U.S. CLS. 1, 4, 6, 50, 51 AND 52).

**CLASS 5—PHARMACEUTICALS**

FOR MEDICATED SKIN CARE PREPARATIONS FOR THE TREATMENT AND PREVENTION OF PHOTO-DAMAGE, PHOTOAGING, INTRINSIC AGING, ACTINIC KERATOSES, SKIN CANCERS, ATOPIC DERMATITIS, TELANGIECTASIA, ECZEMA, PSORIASIS, WRINKLES, ALOPECEA AREATA, LIPODYSTROPHY, DERMATITIS, HYPERPIGMENTATION, ROSACEA, SEBORRHEIC DERMATITIS AND SKIN TAGS; MEDICATED SUN BLOCK AND SUN SCREEN PREPARATIONS; PHARMACEUTICAL PREPARATIONS FOR THE TREATMENT AND PREVENTION OF PHOTO-DAMAGE, PHOTOAGING, INTRINSIC AGING, ACTINIC KERATOSES, SKIN CANCERS, ATOPIC DERMATITIS, TELANGIECTASIA, ECZEMA, PSORIASIS, WRINKLES, ALOPECEA AREATA, LIPODYSTROPHY, DERMATITIS, HYPERPIGMENTATION, ROSACEA, SEBORRHEIC DERMATITIS AND SKIN TAGS; MEDICATED TRANSDERMAL PATCHES FOR THE DELIVERY OF MICRONUTRIENTS FOR TREATMENT OF PHOTODAMAGE, PHOTOAGING, INTRINSIC AGING, ACTINIC KERATOSES, SKIN CANCERS, ATOPIC DERMATITIS, TELANGIECTASIA, ECZEMA, PSORIASIS, WRINKLES, ALOPECEA AREATA, LIPODYSTROPHY, DERMATITIS, HYPERPIGMENTATION, ROSACEA, SEBORRHEIC DERMATITIS AND SKIN TAGS; MEDICATED TRANSDERMAL PATCHES FOR THE TREATMENT OF PHOTODAMAGE, PHOTOAGING, INTRINSIC AGING, ACTINIC KERATOSES, SKIN CANCERS, ATOPIC DERMATITIS, TELANGIECTASIA, ECZEMA, PSORIASIS, WRINKLES, ALOPECEA AREATA, LIPODYSTROPHY, DERMATITIS, HYPERPIGMENTATION, ROSACEA, SEBORRHEIC DERMATITIS AND SKIN TAGS; MEDICATED PRE-MOISTENED TISSUES, TOWELETTES AND WIPES (U.S. CLS. 6, 18, 44, 51 AND 52).

KEVIN DINALLO, EXAMINING ATTORNEY

---

SN 85-154,955. CUTLER-O'NEILL FUNERAL HOME, INC., COUNCIL BLUFFS, IA. FILED 10-18-2010.

**Cutler - O'Neill - Meyer -  
Woodring Funeral Home &  
Crematory**

THE MARK CONSISTS OF STANDARD CHARACTERS WITHOUT CLAIM TO ANY PARTICULAR FONT, STYLE, SIZE, OR COLOR.

NO CLAIM IS MADE TO THE EXCLUSIVE RIGHT TO USE "FUNERAL HOME & CREMATORY", APART FROM THE MARK AS SHOWN.

**CLASS 36—INSURANCE AND FINANCIAL**

FOR PRE-PAID FUNERAL EXPENSE SERVICES (U.S. CLS. 100, 101 AND 102).  
FIRST USE 6-1-2001; IN COMMERCE 6-1-2001.

**CLASS 40—MATERIAL TREATMENT**

FOR CREMATION SERVICES (U.S. CLS. 100, 103 AND 106).  
FIRST USE 6-1-2001; IN COMMERCE 6-1-2001.

**CLASS 45—PERSONAL AND LEGAL SERVICES**

FOR FUNERAL ARRANGEMENT SERVICES (U.S. CLS. 100 AND 101).  
FIRST USE 6-1-2001; IN COMMERCE 6-1-2001.  
JAMES A. RAUEN, EXAMINING ATTORNEY

**CLASS 36—INSURANCE AND FINANCIAL**

FOR FINANCIAL MANAGEMENT, FINANCIAL INFORMATION AND EVALUATION SERVICES, FINANCIAL RESEARCH SERVICES, FINANCIAL CONSULTING; FINANCIAL ADVISORY SERVICES, NAMELY, FINANCIAL ANALYSIS AND CONSULTATION IN THE NATURE OF ASSISTING CLIENTS WITH FINANCIAL AND STRATEGIC INITIATIVES (U.S. CLS. 100, 101 AND 102).

**CLASS 41—EDUCATION AND ENTERTAINMENT**

FOR EDUCATIONAL SERVICES, NAMELY, CONDUCTING COURSES, SEMINARS, WORKSHOPS AND CLASSES IN THE FIELDS OF BUSINESS, BUSINESS MANAGEMENT, MANAGEMENT TRAINING; EDUCATION, TEACHING AND TRAINING, NAMELY, CONDUCTING MULTI-DAY RETREATS FOR EDUCATION, TEACHING AND TRAINING IN THE FIELDS OF BUSINESS, BUSINESS DEVELOPMENT, PERSONAL DEVELOPMENT AND LEADERSHIP TRAINING; ORGANIZING AND CONDUCTING CLASSES, SEMINARS, CONFERENCES, WORKSHOPS AND EXHIBITIONS IN THE FIELDS OF BUSINESS, BUSINESS DEVELOPMENT, PERSONAL DEVELOPMENT AND LEADERSHIP TRAINING (U.S. CLS. 100, 101 AND 107).  
MARK SHINER, EXAMINING ATTORNEY

SN 85-155,064. OXFORD IPC WORLDWIDE LIMITED, WANCHAI, HONG KONG, FILED 10-18-2010.



NO CLAIM IS MADE TO THE EXCLUSIVE RIGHT TO USE "LEADERSHIP ACADEMY", APART FROM THE MARK AS SHOWN.

THE COLOR(S) NAVY BLUE, LIGHT BLUE AND WHITE IS/ARE CLAIMED AS A FEATURE OF THE MARK.

THE MARK CONSISTS OF THE WORDING "OXFORD LEADERSHIP ACADEMY ALIGNING PEOPLE WITH STRATEGY" INSIDE A NAVY BLUE SQUARE WITH WHITE ANGLE BRACKETS IN THE UPPER LEFT AND LOWER RIGHT CORNERS. THE COLOR WHITE ALSO APPEARS IN THE WORDING "OXFORD" AND "ALIGNING PEOPLE WITH STRATEGY". THE COLOR LIGHT BLUE APPEARS IN THE WORDING "LEADERSHIP ACADEMY".

**CLASS 16—PAPER GOODS AND PRINTED MATTER**

FOR PAMPHLETS, BOOKS, NEWSLETTERS, BROCHURES, MAGAZINES, PRINTED REPORTS, JOURNAL, MANUALS AND PRINTED GUIDES, ALL IN THE FIELDS OF BUSINESS, BUSINESS MANAGEMENT AND MANAGEMENT CONSULTING (U.S. CLS. 2, 5, 22, 23, 29, 37, 38 AND 50).

**CLASS 35—ADVERTISING AND BUSINESS**

FOR BUSINESS MANAGEMENT AND BUSINESS CONSULTING AND ADVISORY SERVICES; BUSINESS PROCESS MANAGEMENT AND CONSULTING; BUSINESS MANAGEMENT CONSULTATION IN THE NATURE OF ADVISING CLIENTS ABOUT BUSINESS STRATEGY, ORGANIZATION PERFORMANCE AND BUSINESS RELATED POLICY AREAS; AND BUSINESS RESEARCH SERVICES (U.S. CLS. 100, 101 AND 102).

SN 85-155,104. ALFANO, GABLE A., CLOVIS, CA. FILED 10-18-2010.

**JUST SEW CLASSY**

THE MARK CONSISTS OF STANDARD CHARACTERS WITHOUT CLAIM TO ANY PARTICULAR FONT, STYLE, SIZE, OR COLOR.

**CLASS 18—LEATHER GOODS**

FOR BACKPACKS, BOOK BAGS, SPORTS BAGS, BUM BAGS, WALLETS AND HANDBAGS; EVENING HANDBAGS; FASHION HANDBAGS; HANDBAGS; HANDBAGS FOR LADIES; HANDBAGS, PURSES AND WALLETS; LEATHER HANDBAGS (U.S. CLS. 1, 2, 3, 22 AND 41).

FIRST USE 10-12-2010; IN COMMERCE 10-12-2010.

**CLASS 24—FABRICS**

FOR QUILTS; QUILTS OF TEXTILE (U.S. CLS. 42 AND 50).

FIRST USE 10-12-2010; IN COMMERCE 10-12-2010.  
BRIAN PINO, EXAMINING ATTORNEY

SN 85-155,126. MEDICAL DEPOT, INC., PORT WASHINGTON, NY. FILED 10-18-2010.

**DRIVE MEDICAL**

THE MARK CONSISTS OF STANDARD CHARACTERS WITHOUT CLAIM TO ANY PARTICULAR FONT, STYLE, SIZE, OR COLOR.

OWNER OF U.S. REG. NO. 2,889,659.  
NO CLAIM IS MADE TO THE EXCLUSIVE RIGHT TO  
USE "MEDICAL", APART FROM THE MARK AS SHOWN.

#### CLASS 10—MEDICAL APPARATUS

FOR FOLDING INVALID WALKERS; ROLLATORS; CANES AND CRUTCHES FOR MEDICAL PURPOSES; TOILETS ADAPTED FOR MEDICAL PATIENTS OR FOR USE BY HANDICAPPED PERSONS; BATH SAFETY PRODUCTS ADAPTED FOR USE BY THE PHYSICALLY DISABLED, NAMELY, BATH BENCHES, BATH STOOLS, TOILET SAFETY FRAMES, TOILET SEAT RISERS, TRANSFER BENCHES MADE OF PLASTIC, PADDED TRANSFER BENCHES, RAISED TOILET SEATS, TUB RAILS AND GRAB BARS; DEVICES TO LIFT INVALID PATIENTS, NAMELY, ELECTRIC AND NON-ELECTRIC LIFTS, TRAPEZE BARS AND BASES, U-SLINGS, SLINGS AND COMMODOE SLINGS; OVERDOOR EXERCISE PULLEYS FOR THERAPEUTIC PURPOSES; CERVICAL TRACTION SETS, ADJUSTABLE OXYGEN CARTS, FOUR-LEG IV POLES, FIVE-LEG IV POLES AND FIVE-LEG INFUSION STYLE IV POLES, ALL FOR MEDICAL USE; MEDICAL THERAPY DEVICES, NAMELY, TENS UNITS AND ELECTRONIC MUSCLE STIMULATORS, MEDICAL PERSONAL CARE PRODUCTS, NAMELY, MOIST HEATING PADS, SEAT AND BACK MASSAGERS, BATH MAT MASSAGERS AND INFRARED HEAT WANDS; AND RESPIRATORY PRODUCTS, NAMELY, MEDICAL COMPRESSORS (U.S. CLS. 26, 39 AND 44).

#### CLASS 12—VEHICLES

FOR WHEEL CHAIRS (U.S. CLS. 19, 21, 23, 31, 35 AND 44).

#### CLASS 20—FURNITURE AND ARTICLES NOT OTHERWISE CLASSIFIED

FOR FOOTSTOOLS; FOOTSTOOLS WITH HAND-RAILS; HOSPITAL BED ACCESSORIES, NAMELY, HOME-STYLE BED RAILS, TELESCOPING FULL LENGTH SIDERAILS, UNIVERSAL CROSS BARS, E-Z ASSIST POLES, NO-GAP FILL LENGTH SIDERAILS, HALF RAILS, CLAMPS FOR HALF RAILS, NO-GAP HALF RAILS, CLAMPS FOR NO-GAP HALF RAILS, TELESCOPING HALF RAILS AND T-HALF RAILS; HOSPITAL BEDS; PATIENT ROOM PRODUCTS, NAMELY, NON-TILT OVERBED TABLES, TILT-TOP OVERBED TABLES (U.S. CLS. 2, 13, 22, 25, 32 AND 50).  
DAVID HOFFMAN, EXAMINING ATTORNEY

SN 85-155,162. SUNSTAR SUISSE S.A., ETOY, SWITZERLAND, FILED 10-18-2010.

# EQUITANCE

THE MARK CONSISTS OF STANDARD CHARACTERS WITHOUT CLAIM TO ANY PARTICULAR FONT, STYLE, SIZE, OR COLOR.

THE WORDING "EQUITANCE" HAS NO MEANING IN A FOREIGN LANGUAGE.

#### CLASS 3—COSMETICS AND CLEANING PREPARATIONS

FOR SKIN CLEANSING OIL, SKIN SOAP, SKIN LOTIONS; VISCOUS LOTIONS FOR THE SKIN; SKIN WHITENING CREAMS; TOILETRY CASES CONTAINING TRAVEL-SIZED SKIN CARE PRODUCTS, NAMELY, SKIN CLEANSING CREAMS, SKIN SOAP AND SKIN LOTIONS; PRE-MOISTENED COSMETIC TISSUES, TALCUM POWDER FOR COSMETIC PURPOSES, COLD CREAMS, NON-MEDICATED BATH SALTS, HAND CREAMS, ANTI-PERSPIRANTS, CREAMY FOUNDATIONS, COSMETIC ROUGES, EYE SHADOW, PERFUME, INCENSE, HAIR SPRAY, HAIR SHAMPOOS AND CONDITIONERS, HAIR CREAMS, HAIR TONICS, HAIR DYES, LAUNDRY DETERGENTS, DENTIFRICES, MOUTHWASH, BREATH REFRESHENER IN A TABLET FORM (U.S. CLS. 1, 4, 6, 50, 51 AND 52).

#### CLASS 5—PHARMACEUTICALS

FOR PHARMACEUTICAL PREPARATIONS FOR THE TREATMENT OF DISEASES OF THE EPIDERMIS; NUTRITIONAL SUPPLEMENTS IN TABLET AND LIQUID FORM CONTAINING VITAMINS, MINERALS AND EDIBLE PLANT; NUTRITIONAL SUPPLEMENTS CONTAINING HERBAL EXTRACTS, ALL FOR MEDICINAL PURPOSES; HERBAL TEAS FOR MEDICINAL PURPOSES; DIETETIC BEVERAGES AND FOOD ADAPTED FOR MEDICAL PURPOSES; PROTEIN FOOD SUPPLEMENTS (U.S. CLS. 6, 18, 44, 46, 51 AND 52).

#### CLASS 30—STAPLE FOODS

FOR CONFECTIONERY FOOD PRODUCTS, NAMELY, BISCUITS, CANDY, NON-MEDICATED LOZENGES, CHEWING GUM NOT FOR MEDICAL USE, CRACKERS; CEREAL-BASED SNACK FOODS; GRAIN-BASED SNACK FOODS; OAT-BASED SNACK FOODS (U.S. CL. 46).

#### CLASS 32—LIGHT BEVERAGES

FOR NON-ALCOHOLIC BEVERAGES, NAMELY, ISOTONIC BEVERAGES, FRUIT DRINKS, WHEY BEVERAGES, VEGETABLE JUICES, MINERAL WATER, POWDERED DRINK MIXES FOR USE IN PREPARATION OF SPORTS DRINKS; BEAUTY BEVERAGES, NAMELY, FRUIT JUICES CONTAINING COLLAGEN (U.S. CLS. 45, 46 AND 48).

BRIAN PINO, EXAMINING ATTORNEY

SN 85-155,987. DIBS ON BIBS, LLC, ORLANDO, FL. FILED 10-19-2010.

# Dibs on Bibs

THE MARK CONSISTS OF STANDARD CHARACTERS WITHOUT CLAIM TO ANY PARTICULAR FONT, STYLE, SIZE, OR COLOR.

NO CLAIM IS MADE TO THE EXCLUSIVE RIGHT TO USE "BIBS", APART FROM THE MARK AS SHOWN.

#### CLASS 24—FABRICS

FOR BURP CLOTHS (U.S. CLS. 42 AND 50).

#### CLASS 25—CLOTHING

FOR BIBS NOT OF PAPER (U.S. CLS. 22 AND 39).  
ANDREA K. NADELMAN, EXAMINING ATTORNEY

SN 85-156,466. MODERN MEMOIRS, INC., AMHERST, MA.  
FILED 10-19-2010.



OWNER OF U.S. REG. NO. 3,891,260.  
NO CLAIM IS MADE TO THE EXCLUSIVE RIGHT TO USE "PRESS", APART FROM THE MARK AS SHOWN.  
THE MARK CONSISTS OF A FLOWER WITH THE WORDING "WHITE POPPY PRESS \*\* WHITE POPPY PRESS\*\*" AROUND THE OUTER PORTION OF THE FLOWER AND A BAND OF DOTS ENCLOSING THE WORDING AND FLOWER.

#### CLASS 35—ADVERTISING AND BUSINESS

FOR CONSULTING SERVICES, NAMELY, CONSULTATION, INFORMATION AND ADVICE IN THE FIELD OF MARKETING AND SELLING OF BOOKS; ONLINE ORDERING SERVICES FEATURING BOOKS; DISTRIBUTORSHIP SERVICES IN THE FIELD OF BOOKS (U.S. CLS. 100, 101 AND 102).

FIRST USE 8-25-2010; IN COMMERCE 8-25-2010.

#### CLASS 41—EDUCATION AND ENTERTAINMENT

FOR CONSULTING SERVICES, NAMELY, CONSULTATION, INFORMATION AND ADVICE IN THE FIELD OF SELF-PUBLISHING OF BOOKS; PUBLISHING OF BOOKS AND E-BOOKS; DESKTOP PUBLISHING FOR OTHERS; DIGITAL AUDIO AND MULTIMEDIA PUBLISHING SERVICES; ONLINE ELECTRONIC PUBLISHING OF BOOKS; LAYOUT SERVICES OTHER THAN FOR ADVERTISING PURPOSES; WRITTEN TEXT EDITING, PHOTOGRAPH EDITING, AUDIO AND VIDEO RECORDING SERVICES IN CONNECTION WITH BOOKS; WRITING OF TEXTS FOR BOOKS; CONSULTATION SERVICES IN THE FIELD OF WRITTEN TEXT EDITING (U.S. CLS. 100, 101 AND 107).

FIRST USE 8-25-2010; IN COMMERCE 8-25-2010.  
IRA J. GOODSAY, EXAMINING ATTORNEY

SN 85-156,563. CITIGROUP INC., NEW YORK, NY. FILED  
10-19-2010.

# CITI FUSION

THE MARK CONSISTS OF STANDARD CHARACTERS WITHOUT CLAIM TO ANY PARTICULAR FONT, STYLE, SIZE, OR COLOR.  
OWNER OF U.S. REG. NOS. 1,181,467, 3,555,337 AND OTHERS.

#### CLASS 35—ADVERTISING AND BUSINESS

FOR PROMOTING THE GOODS AND SERVICES OF OTHERS THROUGH ADMINISTRATION OF INCENTIVE REWARD AND REDEMPTION PROGRAMS BY DISTRIBUTING REWARDS FOR CREDIT CARD USE (U.S. CLS. 100, 101 AND 102).

#### CLASS 36—INSURANCE AND FINANCIAL

FOR CREDIT CARD SERVICES (U.S. CLS. 100, 101 AND 102).

JOHN GARTNER, EXAMINING ATTORNEY

SN 85-156,673. MED-EL ELEKTROMEDIZINISCHE GERÄTE  
GES.M.B.H., 6020 INNSBRUCK, AUSTRIA, FILED 10-20-  
2010.

# STIWELL

THE MARK CONSISTS OF STANDARD CHARACTERS WITHOUT CLAIM TO ANY PARTICULAR FONT, STYLE, SIZE, OR COLOR.

OWNER OF ERPN CMNTY TM OFC REG. NO. 4072542,  
DATED 12-23-2005, EXPIRES 10-13-2014.  
OWNER OF U.S. REG. NO. 2,901,186.

#### CLASS 9—ELECTRICAL AND SCIENTIFIC APPARATUS

FOR COMPUTERS; DATA PROCESSORS; COMPUTER MEMORY BOARDS; COMPUTER OPERATING SOFTWARE AND COMPUTER DISKETTES CONTAINING OPERATING SOFTWARE FOR PHYSIOTHERAPY, NAMELY, FOR USE IN THE FIELD OF ELECTRIC STIMULATION OF A PATIENT'S BODY OR ANY PARTS THEREOF FOR MEDICAL AND PARAMEDICAL PURPOSES (U.S. CLS. 21, 23, 26, 36 AND 38).

#### CLASS 10—MEDICAL APPARATUS

FOR ELECTROTHERAPY DEVICES FOR PROVIDING TRANSCUTANEOUS ELECTRICAL STIMULATION; ARTIFICIAL LIMBS; MEDICAL ELECTRODES; COMPUTERIZED PHYSICAL THERAPY EXERCISE APPARATUS FOR MEDICAL PURPOSES (U.S. CLS. 26, 39 AND 44).

#### CLASS 28—TOYS AND SPORTING GOODS

FOR PERSONAL EXERCISE MATS; SPORT BALLS AND STRETCH BANDS FOR PHYSICAL FITNESS PURPOSES; JUMP ROPES; MANUALLY-OPERATED EXERCISE EQUIPMENT FOR BODYBUILDING AND PHYSICAL FITNESS (U.S. CLS. 22, 23, 38 AND 50).  
IRA J. GOODSAY, EXAMINING ATTORNEY

SN 85-156,695. BIG TIME HOLDINGS, INC., ROME, GA.  
FILED 10-20-2010.

SN 85-156,886. 24 TRAUMA, LLC, EASTON, MA. FILED 10-20-2010.

## NATURAL WRIST

THE MARK CONSISTS OF STANDARD CHARACTERS WITHOUT CLAIM TO ANY PARTICULAR FONT, STYLE, SIZE, OR COLOR.

### CLASS 9—ELECTRICAL AND SCIENTIFIC APPARATUS

FOR PROTECTIVE GLOVES FOR INDUSTRIAL USE (U.S. CLS. 21, 23, 26, 36 AND 38).

### CLASS 21—HOUSEWARES AND GLASS

FOR GARDENING GLOVES (U.S. CLS. 2, 13, 23, 29, 30, 33, 40 AND 50).

### CLASS 25—CLOTHING

FOR GLOVES (U.S. CLS. 22 AND 39).  
JAMES LOVELACE, EXAMINING ATTORNEY

---

SN 85-156,852. SHEER DRIVE LLC, WHITE PLAINS, NY.  
FILED 10-20-2010.



THE MARK CONSISTS OF THE STYLIZED WORDING "SHEER DRIVE" WITH A FLAME DESIGN EMANATING FROM THE WORDING.

### CLASS 25—CLOTHING

FOR JACKETS; PANTS; SHIRTS (U.S. CLS. 22 AND 39).

### CLASS 41—EDUCATION AND ENTERTAINMENT

FOR PHYSICAL FITNESS CONSULTATION; PHYSICAL FITNESS TRAINING OF INDIVIDUALS AND GROUPS; PROVIDING A WEB SITE FEATURING INFORMATION ON EXERCISE AND FITNESS (U.S. CLS. 100, 101 AND 107).  
LINDA M. KING, EXAMINING ATTORNEY

## 24TRAUMA

THE MARK CONSISTS OF STANDARD CHARACTERS WITHOUT CLAIM TO ANY PARTICULAR FONT, STYLE, SIZE, OR COLOR.

### CLASS 37—CONSTRUCTION AND REPAIR

FOR JANITORIAL SERVICES; TRASH COLLECTION; REMOVAL AND DISPOSAL OF HAZARDOUS MATERIAL (U.S. CLS. 100, 103 AND 106).

FIRST USE 10-0-2010; IN COMMERCE 10-0-2010.

### CLASS 39—TRANSPORTATION AND STORAGE

FOR JUNK, TRASH AND DEBRIS REMOVAL; GARBAGE COLLECTION (U.S. CLS. 100 AND 105).

FIRST USE 10-0-2010; IN COMMERCE 10-0-2010.

### CLASS 40—MATERIAL TREATMENT

FOR BIOREMEDIATION SERVICES; DECONTAMINATION AND SANITIZATION OF PROPERTY, CRIME AND ACCIDENT SCENES (U.S. CLS. 100, 103 AND 106).

FIRST USE 10-0-2010; IN COMMERCE 10-0-2010.

PAM WILLIS, EXAMINING ATTORNEY

---

SN 85-157,020. PROMOTION IN MOTION, INC., CLOSTER, NJ. FILED 10-20-2010.

## FUN SNACKS

THE MARK CONSISTS OF STANDARD CHARACTERS WITHOUT CLAIM TO ANY PARTICULAR FONT, STYLE, SIZE, OR COLOR.

NO CLAIM IS MADE TO THE EXCLUSIVE RIGHT TO USE "SNACKS", APART FROM THE MARK AS SHOWN.

### CLASS 29—MEATS AND PROCESSED FOODS

FOR PROCESSED FRUIT SNACKS, NAMELY, PROCESSED FRUIT PIECES AND PROCESSED FRUIT ROLLS, MADE WITH INGREDIENTS INCLUDING FRUIT AND FRUIT JUICE (U.S. CL. 46).

### CLASS 30—STAPLE FOODS

FOR CANDY AND CHOCOLATE (U.S. CL. 46).  
TOBY BULLOFF, EXAMINING ATTORNEY

SN 85-157,030. 1440 CABLE FACTORY, PHOENIX, AZ.  
FILED 10-20-2010.

SN 85-157,147. ONNE VAN DER LAAK, FLAGSTAFF, AZ.  
FILED 10-20-2010.

## Ride The cable

THE MARK CONSISTS OF STANDARD CHARACTERS WITHOUT CLAIM TO ANY PARTICULAR FONT, STYLE, SIZE, OR COLOR.

### CLASS 25—CLOTHING

FOR ATHLETIC APPAREL, NAMELY, SHIRTS, PANTS, JACKETS, FOOTWEAR, HATS AND CAPS, ATHLETIC UNIFORMS (U.S. CLS. 22 AND 39).

### CLASS 35—ADVERTISING AND BUSINESS

FOR ADVERTISING AND BUSINESS SERVICES, NAMELY, PROVIDING AN ONLINE WEBSITE WHERE ADVERTISERS, MARKETERS, AND CONTENT PROVIDERS CAN INTERACT WITH USERS FOR ADVERTISING, BRANDING, AND PROMOTING KNOWLEDGE, PRODUCTS, AND SERVICES, AND TRADESHOWS, ON BEHALF OF THEMSELVES AND OTHERS, AND FOR EVALUATING AND RATING THE SAME, ALL THE FOREGOING RELEVANT TO HUMAN ACTIVITIES AFFECTING CLIMATE CHANGE AND RELATED FIELDS (U.S. CLS. 100, 101 AND 102).

REBECCA POVARCHUK, EXAMINING ATTORNEY

SN 85-157,089. PRIDE MANUFACTURING COMPANY, LLC,  
BRENTWOOD, TN. FILED 10-20-2010.

## PRIDESPORTS

THE MARK CONSISTS OF STANDARD CHARACTERS WITHOUT CLAIM TO ANY PARTICULAR FONT, STYLE, SIZE, OR COLOR.

OWNER OF U.S. REG. NO. 3,904,487.

### CLASS 18—LEATHER GOODS

FOR GOLF UMBRELLAS (U.S. CLS. 1, 2, 3, 22 AND 41).

### CLASS 28—TOYS AND SPORTING GOODS

FOR GOLF PRACTICE NETS; GOLF DRIVING PRACTICE MATS; GOLF PUTTING PRACTICE MATS; GOLF BALL SHAG BAGS USED TO STORE GOLF BALLS, AND BAGS SPECIALLY ADAPTED FOR HOLDING GOLF CLUBS AND GOLF EQUIPMENT; TRAVEL BAGS FOR GOLF CLUBS (U.S. CLS. 22, 23, 38 AND 50).

JUSTINE D. PARKER, EXAMINING ATTORNEY

## THE FLIPPIN' DUTCH

THE MARK CONSISTS OF STANDARD CHARACTERS WITHOUT CLAIM TO ANY PARTICULAR FONT, STYLE, SIZE, OR COLOR.

### CLASS 30—STAPLE FOODS

FOR PANCAKES IN PLAIN FORM; PANCAKES FILLED WITH FRUITS, VEGETABLES, MEATS AND CHEESES; SYRUPS AND SAUCES FOR PANCAKES (U.S. CL. 46).

### CLASS 43—HOTEL AND RESTAURANT SERVICES

FOR RESTAURANT SERVICES (U.S. CLS. 100 AND 101).

RENEE MCCRAY, EXAMINING ATTORNEY

SN 85-157,160. TIME AFTER TIME, INC., RICHBORO, PA.  
FILED 10-20-2010.

## TIME AFTER TIME

THE MARK CONSISTS OF STANDARD CHARACTERS WITHOUT CLAIM TO ANY PARTICULAR FONT, STYLE, SIZE, OR COLOR.

### CLASS 35—ADVERTISING AND BUSINESS

FOR RETAIL STORE SERVICES FEATURING WATCHES AND WATCH-RELATED ACCESSORIES (U.S. CLS. 100, 101 AND 102).

FIRST USE 11-0-1990; IN COMMERCE 0-0-1993.

### CLASS 37—CONSTRUCTION AND REPAIR

FOR WATCH REPAIR SERVICES; INSTALLATION AND REPLACEMENT OF WATCH RELATED ACCESSORIES AND COMPONENTS (U.S. CLS. 100, 103 AND 106).

FIRST USE 11-0-1990; IN COMMERCE 0-0-1993.  
LINDA LAVACHE, EXAMINING ATTORNEY

SN 85-157,237. TENTEXCOTA, LLC, RAPID CITY, SD. FILED 10-20-2010.

SN 85-157,498. ILICH, MARK, LOS ANGELES, CA. AND WHITE, ANNE HOWARD, LOS ANGELES, CA. FILED 10-20-2010.

## DEADWOOD MOUNTAIN GRAND

THE MARK CONSISTS OF STANDARD CHARACTERS WITHOUT CLAIM TO ANY PARTICULAR FONT, STYLE, SIZE, OR COLOR.

NO CLAIM IS MADE TO THE EXCLUSIVE RIGHT TO USE "DEADWOOD", APART FROM THE MARK AS SHOWN.

### CLASS 41—EDUCATION AND ENTERTAINMENT

FOR CASINO GAMING ENTERTAINMENT SERVICES (U.S. CLS. 100, 101 AND 107).

### CLASS 43—HOTEL AND RESTAURANT SERVICES

FOR HOTEL AND RESTAURANT SERVICES (U.S. CLS. 100 AND 101).  
FLORENTINA BLANDU, EXAMINING ATTORNEY

---

SN 85-157,322. UNION SQUARE OPTICAL, INC., NEW YORK, NY. FILED 10-20-2010.

## UNION SQUARE OPTICAL

THE MARK CONSISTS OF STANDARD CHARACTERS WITHOUT CLAIM TO ANY PARTICULAR FONT, STYLE, SIZE, OR COLOR.

NO CLAIM IS MADE TO THE EXCLUSIVE RIGHT TO USE "OPTICAL", APART FROM THE MARK AS SHOWN.

### CLASS 35—ADVERTISING AND BUSINESS

FOR RETAIL OPTICAL STORE SERVICES (U.S. CLS. 100, 101 AND 102).  
FIRST USE 4-0-1992; IN COMMERCE 4-0-1992.

### CLASS 44—MEDICAL, BEAUTY AND AGRICULTURAL SERVICES

FOR OPTICIAN AND OPTOMETRIC SERVICES (U.S. CLS. 100 AND 101).  
FIRST USE 4-0-1992; IN COMMERCE 4-0-1992.  
DORITT L. CARROLL, EXAMINING ATTORNEY

## The World of Maggie McCalister

THE MARK CONSISTS OF STANDARD CHARACTERS WITHOUT CLAIM TO ANY PARTICULAR FONT, STYLE, SIZE, OR COLOR.

THE NAME(S), PORTRAIT(S), AND/OR SIGNATURE(S) SHOWN IN THE MARK DOES NOT IDENTIFY A PARTICULAR LIVING INDIVIDUAL.

### CLASS 5—PHARMACEUTICALS

FOR MULTI-VITAMIN PREPARATIONS; VITAMINS (U.S. CLS. 6, 18, 44, 46, 51 AND 52).

### CLASS 9—ELECTRICAL AND SCIENTIFIC APPARATUS

FOR COMPUTER GAME CARTRIDGES; COMPUTER GAME CARTRIDGES AND DISCS; COMPUTER GAME CASSETTES; COMPUTER GAME SOFTWARE; COMPUTER GAME SOFTWARE FOR USE WITH PERSONAL COMPUTERS, HOME VIDEO GAME CONSOLES USED WITH TELEVISIONS AND ARCADE-BASED VIDEO GAME CONSOLES; COMPUTER PROGRAMS FOR VIDEO AND COMPUTER GAMES; DOWNLOADABLE COMPUTER GAME PROGRAMS; DOWNLOADABLE ELECTRONIC GAME PROGRAMS; ELECTRONIC GAME PROGRAMS; ELECTRONIC GAME SOFTWARE (U.S. CLS. 21, 23, 26, 36 AND 38).

### CLASS 16—PAPER GOODS AND PRINTED MATTER

FOR A SERIES OF BOOKS AND WRITTEN ARTICLES IN THE FIELD OF CHILDREN'S STORIES; BOOK COVERS; BOOK MARKERS; CHILDREN'S ACTIVITY BOOKS; CHILDREN'S BOOKS; CHILDREN'S INTERACTIVE EDUCATIONAL BOOKS; COLORING BOOKS; NOTE BOOKS; PAPER STATIONERY; SCHOOL SUPPLY KITS CONTAINING VARIOUS COMBINATIONS OF SELECTED SCHOOL SUPPLIES, NAMELY, WRITING INSTRUMENTS, PENS, PENCILS, MECHANICAL PENCILS, ERASERS, MARKERS, CRAYONS, HIGHLIGHTER PENS, FOLDERS, NOTEBOOKS, PAPER, PROTRACTORS, PAPER CLIPS, PENCIL SHARPENERS, WRITING GRIPS, GLUE AND BOOK MARKS; SCHOOL WRITING BOOKS; SCRAP BOOKS; SERIES OF FICTION BOOKS; SERIES OF FICTION WORKS, NAMELY, NOVELS AND BOOKS; SKETCH BOOKS; SONG BOOKS; STATIONERY; STATIONERY FOLDERS; STATIONERY WRITING PAPER AND ENVELOPES; STATIONERY-TYPEPORTFOLIOS; STICKERS; STORY BOOKS; TALKING CHILDREN'S BOOKS; WIREBOUND BOOKS (U.S. CLS. 2, 5, 22, 23, 29, 37, 38 AND 50).

### CLASS 25—CLOTHING

FOR HATS; HATS FOR INFANTS, BABIES, TODDLERS AND CHILDREN; PAJAMAS; PANTS; SHIRTS; SHIRTS FOR INFANTS, BABIES, TODDLERS AND CHILDREN; T-SHIRTS (U.S. CLS. 22 AND 39).

**CLASS 28—TOYS AND SPORTING GOODS**

FOR CARD GAMES; ELECTRONIC GAMES FOR THE TEACHING OF CHILDREN; ELECTRONIC LEARNING TOYS; INFLATABLE TOYS; MECHANICAL TOYS; MOLDED TOY FIGURES; PLUSH TOYS; PUZZLE GAMES; RUBBER CHARACTER TOYS; STUFFED TOYS; TABLETOP GAMES; TALKING TOYS; TOY ACTION FIGURES; TOY ACTION FIGURES AND ACCESSORIES THEREFOR; TOY AND NOVELTY FACE MASKS; TOY CLOCKS AND WATCHES; TOY FIGURES; TOY, NAMELY, BATTERY-POWERED COMPUTER GAME WITH LCD SCREEN WHICH FEATURES ANIMATION AND SOUND EFFECTS; TOYS, NAMELY, CHILDREN'S DRESS-UP ACCESSORIES; TRADING CARD GAMES (U.S. CLS. 22, 23, 38 AND 50).

**CLASS 30—STAPLE FOODS**

FOR BREAKFAST CEREALS; CEREAL-BASED SNACK FOODS; READY-TO-EAT CEREALS (U.S. CL. 46).

**CLASS 41—EDUCATION AND ENTERTAINMENT**

FOR EDUCATIONAL AND ENTERTAINMENT SERVICES, NAMELY, A CONTINUING PROGRAM ABOUT CHILDREN'S STORIES ACCESSIBLE BY RADIO, TELEVISION, SATELLITE, AUDIO, VIDEO AND COMPUTER NETWORKS; ENTERTAINMENT IN THE NATURE OF ON-GOING TELEVISION PROGRAMS IN THE FIELD OF CHILDREN'S STORIES; ENTERTAINMENT SERVICES IN THE NATURE OF ON-GOING TELEVISION PROGRAMS IN THE FIELD OF CHILDREN'S ENTERTAINMENT; PRODUCTION OF DVDS, VIDEOTAPES AND TELEVISION PROGRAMS FEATURING CHILDREN'S STORIES (U.S. CLS. 100, 101 AND 107).

PRISCILLA MILTON, EXAMINING ATTORNEY

---

SN 85-157,573. LIVE AND DREAM GREEN LLC, AVON, CT. FILED 10-20-2010.



THE COLOR(S) GREEN, BROWN IS/ARE CLAIMED AS A FEATURE OF THE MARK.

THE MARK CONSISTS OF A GREEN BIRD SHAPED LIKE A BAG WITH THE FLAP OF THE BAG IN BROWN REPRESENTING ITS WING, BROWN EYE LOCATED ON THE FLAP, BROWN BEAK, AND TWO BROWN SKINNY LEGS WITH THREE POINT TOES.

**CLASS 16—PAPER GOODS AND PRINTED MATTER**

FOR LUNCH BAGS MADE OF TEXTILE (U.S. CLS. 2, 5, 22, 23, 29, 37, 38 AND 50).  
FIRST USE 4-23-2009; IN COMMERCE 5-17-2009.

**CLASS 18—LEATHER GOODS**

FOR ALL-PURPOSE REUSABLE CARRYING BAGS (U.S. CLS. 1, 2, 3, 22 AND 41).  
FIRST USE 4-23-2009; IN COMMERCE 5-17-2009.  
ANDREW LEASER, EXAMINING ATTORNEY

SN 85-157,706. FARMERS GROUP, INC., LOS ANGELES, CA. FILED 10-21-2010.

**FARMERS FIELD**

THE MARK CONSISTS OF STANDARD CHARACTERS WITHOUT CLAIM TO ANY PARTICULAR FONT, STYLE, SIZE, OR COLOR.

**CLASS 25—CLOTHING**

FOR MEN'S, WOMEN'S AND CHILDREN'S CLOTHING, NAMELY, CAPS, HATS, VISORS, SHIRTS, SWEATERS, JACKETS, SHORTS, JOGGING SUITS, PANTS, SOCKS, JERSEYS (U.S. CLS. 22 AND 39).

**CLASS 41—EDUCATION AND ENTERTAINMENT**

FOR PROVIDING FACILITIES FOR SPORTING EVENTS; PROVIDING FACILITIES FOR ENTERTAINMENT EVENTS, NAMELY, MUSIC CONCERTS; PROVIDING STADIUM FACILITIES FOR SPORTS AND RECREATIONAL ACTIVITIES, NAMELY, FOOTBALL, SOCCER, BASKETBALL, HOCKEY, TENNIS, GYMNASTICS, VOLLEYBALL, BASEBALL, BADMINTON, AND WALKATHONS; ENTERTAINMENT IN THE NATURE OF ORGANIZING AND CONDUCTING SPORTS EVENTS, CONCERTS, CULTURAL EVENTS, COMPETITIONS, AND FESTIVALS; ARRANGING FOR TICKET RESERVATIONS FOR SPORTS EVENTS, CONCERTS, CULTURAL EVENTS, COMPETITIONS AND FESTIVALS (U.S. CLS. 100, 101 AND 107).

**CLASS 43—HOTEL AND RESTAURANT SERVICES**

FOR ARENA SERVICES, NAMELY, PROVIDING FACILITIES FOR SPORTS, CONCERTS, CONVENTIONS AND EXHIBITIONS; PROVIDING FACILITIES FOR EXHIBITIONS (U.S. CLS. 100 AND 101).  
SHAUNIA CARLYLE, EXAMINING ATTORNEY

---

SN 85-157,817. ZERO MOTORCYCLES, INC., SCOTTS VALLEY, CA. FILED 10-21-2010.

**ZEROCROSS**

THE MARK CONSISTS OF STANDARD CHARACTERS WITHOUT CLAIM TO ANY PARTICULAR FONT, STYLE, SIZE, OR COLOR.  
OWNER OF U.S. REG. NOS. 3,661,976 AND 3,669,900.

**CLASS 9—ELECTRICAL AND SCIENTIFIC APPARATUS**

FOR BATTERIES FOR VEHICLES; BATTERIES, ELECTRIC, FOR VEHICLES; BATTERY CABLES; BATTERY CHARGERS (U.S. CLS. 21, 23, 26, 36 AND 38).



**CLASS 12—VEHICLES**

FOR ELECTRIC DRIVES FOR VEHICLES; ELECTRIC MOTORCYCLES; ELECTRIC VEHICLES, NAMELY, MOTORCYCLES; GEARBOXES FOR LAND VEHICLES; LAND VEHICLE ENGINE REBUILD KITS, SOLD AS A UNIT; LAND VEHICLE PARTS, NAMELY, DRIVE BELTS; LAND VEHICLE PARTS, NAMELY, DRIVE GEARS; LAND VEHICLE PARTS, NAMELY, TRANSMISSIONS; LAND VEHICLE TRANSMISSION REBUILD-KITS, SOLD AS A UNIT; LAND VEHICLE TRANSMISSIONS AND REPLACEMENT PARTS THEREOF; MOTORCYCLE ENGINES; MOTORCYCLES; MOTORCYCLES AND STRUCTURAL PARTS THEREFOR; MOTORCYCLES FOR MOTOCROSS; MOTORS FOR LAND VEHICLES; STRUCTURAL PARTS FOR MOTORCYCLES; THREE-WHEELED MOTOR VEHICLES; VEHICLE POWER TRAIN MECHANISM COMPRISED OF CLUTCH, TRANSMISSION, DRIVE SHAFT, AND DIFFERENTIAL (U.S. CLS. 19, 21, 23, 31, 35 AND 44).

SN 85-157,961. FISH & ASSOCIATES, PC, IRVINE, CA. FILED 10-21-2010.

**GREENFIELD PATENTING**

THE MARK CONSISTS OF STANDARD CHARACTERS WITHOUT CLAIM TO ANY PARTICULAR FONT, STYLE, SIZE, OR COLOR.

NO CLAIM IS MADE TO THE EXCLUSIVE RIGHT TO USE "PATENTING", APART FROM THE MARK AS SHOWN.

**CLASS 35—ADVERTISING AND BUSINESS**

FOR ON-LINE RETAIL STORE SERVICES FEATURING MOTORCYCLES, MOTORCYCLE ACCESSORIES, APPAREL FOR MOTORCYCLISTS, AND PARTS FOR MOTORCYCLES (U.S. CLS. 100, 101 AND 102).  
DEIRDRE ROBERTSON, EXAMINING ATTORNEY

**CLASS 16—PAPER GOODS AND PRINTED MATTER**

FOR PRINTED INSTRUCTIONAL, EDUCATIONAL, AND TEACHING MATERIALS IN THE FIELD OF DEVELOPING, PATENTING, AND MARKETING INVENTIONS (U.S. CLS. 2, 5, 22, 23, 29, 37, 38 AND 50).

**CLASS 45—PERSONAL AND LEGAL SERVICES**

FOR LEGAL SERVICES, NAMELY, PREPARATION AND PROSECUTION OF PATENT APPLICATIONS (U.S. CLS. 100 AND 101).

GRETCHEN ULRICH, EXAMINING ATTORNEY

SN 85-157,945. FISH & ASSOCIATES, PC, IRVINE, CA. FILED 10-21-2010.

SN 85-157,969. FLY TRADEMARK, INC., WOODSTOCK, GA. FILED 10-21-2010.

**BLUE SKY PATENTING**

THE MARK CONSISTS OF STANDARD CHARACTERS WITHOUT CLAIM TO ANY PARTICULAR FONT, STYLE, SIZE, OR COLOR.

NO CLAIM IS MADE TO THE EXCLUSIVE RIGHT TO USE "PATENTING", APART FROM THE MARK AS SHOWN.

**CLASS 16—PAPER GOODS AND PRINTED MATTER**

FOR PRINTED INSTRUCTIONAL, EDUCATIONAL, AND TEACHING MATERIALS IN THE FIELD OF DEVELOPING, PATENTING, AND MARKETING INVENTIONS (U.S. CLS. 2, 5, 22, 23, 29, 37, 38 AND 50).

**CLASS 45—PERSONAL AND LEGAL SERVICES**

FOR LEGAL SERVICES, NAMELY, PREPARATION AND PROSECUTION OF PATENT APPLICATIONS (U.S. CLS. 100 AND 101).

GRETCHEN ULRICH, EXAMINING ATTORNEY



THE MARK CONSISTS OF A BUTTON AND ZIPPER WITH THE WORD "FLY" NEXT TO THE ZIPPER.

**CLASS 16—PAPER GOODS AND PRINTED MATTER**

FOR GIFT BAGS AND LABELS USED IN CONNECTION WITH ALCOHOLIC BEVERAGES, NAMELY, PAPER GIFT BAGS, PAPER GIFT BAGS FOR WINE, PAPER GIFT TAGS, PAPER LABELS, PRINTED PAPER LABELS, PRINTED NOVELTY WINE LABELS (U.S. CLS. 2, 5, 22, 23, 29, 37, 38 AND 50).

**CLASS 25—CLOTHING**

FOR CLOTHING, NAMELY, SWEATERS, SHIRTS, T-SHIRTS, POLO SHIRTS, SWEATSHIRTS, VESTS, PANTS, SHORTS, SOCKS, JACKETS, EARMUFFS, SCARVES, GLOVES AND HEADGEAR, NAMELY, HATS, CAPS AND VISORS, AND HEADBANDS (U.S. CLS. 22 AND 39).

**CLASS 32—LIGHT BEVERAGES**

FOR BREWED MALT-BASED ALCOHOLIC BEVERAGES IN THE NATURE OF A BEER (U.S. CLS. 45, 46 AND 48).

**CLASS 33—WINES AND SPIRITS**

FOR ALCOHOLIC BEVERAGES, NAMELY, FORTIFIED WINES, STILL WINES, WHITE WINES, RED WINES, SPARKLING WINES, PORT WINES, SWEET WINES, TABLE WINES, COOKING WINES, BEVERAGES CONTAINING WINE IN THE NATURE OF WINE BASED DRINKS, SPARKLING FRUIT WINES AND STILL FRUIT WINES; READY TO DRINK ALCOHOLIC BEVERAGES IN THE NATURE OF WINE BASED DRINKS; LIQUOR AND LIQUEUR BEVERAGES, NAMELY, DISTILLED LIQUOR; PREPARED ALCOHOLIC COCKTAILS, ALCOHOLIC COCKTAIL MIXES (U.S. CLS. 47 AND 49).

MARGERY A. TIERNEY, EXAMINING ATTORNEY

SN 85-157,976. FLY TRADEMARK, INC., WOODSTOCK, GA. FILED 10-21-2010.



THE MARK CONSISTS OF A BUTTON AND ZIPPER ON DENIM APPEARING MATERIAL WITH THE WORD "FLY" NEXT TO THE ZIPPER.

**CLASS 16—PAPER GOODS AND PRINTED MATTER**

FOR GIFT BAGS AND LABELS USED IN CONNECTION WITH ALCOHOLIC BEVERAGES, NAMELY, PAPER GIFT BAGS, PAPER GIFT BAGS FOR WINE, PAPER GIFT TAGS, PAPER LABELS, PRINTED PAPER LABELS, PRINTED NOVELTY WINE LABELS (U.S. CLS. 2, 5, 22, 23, 29, 37, 38 AND 50).

**CLASS 25—CLOTHING**

FOR CLOTHING, NAMELY, SWEATERS, SHIRTS, T-SHIRTS, POLO SHIRTS, SWEATSHIRTS, VESTS, PANTS, SHORTS, SOCKS, JACKETS, EARMUFFS, SCARVES, GLOVES AND HEADGEAR, NAMELY, HATS, CAPS AND VISORS, AND HEADBANDS (U.S. CLS. 22 AND 39).

**CLASS 32—LIGHT BEVERAGES**

FOR BREWED MALT-BASED ALCOHOLIC BEVERAGES IN THE NATURE OF A BEER (U.S. CLS. 45, 46 AND 48).

**CLASS 33—WINES AND SPIRITS**

FOR ALCOHOLIC BEVERAGES, NAMELY, FORTIFIED WINES, STILL WINES, WHITE WINES, RED WINES, SPARKLING WINES, PORT WINES, SWEET WINES, TABLE WINES, COOKING WINES, BEVERAGES CONTAINING WINE IN THE NATURE OF WINE BASED DRINKS, SPARKLING FRUIT WINES AND STILL FRUIT WINES; READY TO DRINK ALCOHOLIC BEVERAGES IN THE NATURE OF WINE BASED DRINKS; LIQUOR AND LIQUEUR BEVERAGES, NAMELY, DISTILLED LIQUOR; PREPARED ALCOHOLIC COCKTAILS, ALCOHOLIC COCKTAIL MIXES (U.S. CLS. 47 AND 49).

MARGERY A. TIERNEY, EXAMINING ATTORNEY

SN 85-158,048. B.C.S. INTERNATIONAL CORPORATION, LONG ISLAND CITY, NY. FILED 10-21-2010.

**NUT MAN**

THE MARK CONSISTS OF STANDARD CHARACTERS WITHOUT CLAIM TO ANY PARTICULAR FONT, STYLE, SIZE, OR COLOR.

NO CLAIM IS MADE TO THE EXCLUSIVE RIGHT TO USE "NUT", APART FROM THE MARK AS SHOWN.

**CLASS 29—MEATS AND PROCESSED FOODS**

FOR PROCESSED NUTS; DRIED FRUITS (U.S. CL. 46).

**CLASS 31—NATURAL AGRICULTURAL PRODUCTS**

FOR RAW NUTS (U.S. CLS. 1 AND 46).  
KIMBERLY FRYE, EXAMINING ATTORNEY

SN 85-158,161. 24 TRAUMA, LLC, EASTON, MA. FILED 10-21-2010.

THE COLOR(S) RED AND BLACK IS/ARE CLAIMED AS A FEATURE OF THE MARK.

THE MARK CONSISTS OF THE NUMBER "24" WRITTEN IN RED TO THE LEFT OF THE WORD "TRAUMA" WRITTEN IN BLACK; THE NUMBER IS TALLER THAN THE WORD.

**CLASS 37—CONSTRUCTION AND REPAIR**

FOR JANITORIAL SERVICES; TRASH COLLECTION; REMOVAL AND DISPOSAL OF HAZARDOUS MATERIAL (U.S. CLS. 100, 103 AND 106).

FIRST USE 10-0-2010; IN COMMERCE 10-0-2010.

**CLASS 39—TRANSPORTATION AND STORAGE**

FOR JUNK, TRASH AND DEBRIS REMOVAL; GARBAGE COLLECTION (U.S. CLS. 100 AND 105).

FIRST USE 10-0-2010; IN COMMERCE 10-0-2010.

**CLASS 40—MATERIAL TREATMENT**

FOR BIOREMEDIATION SERVICES; DECONTAMINATION AND SANITIZATION OF PROPERTY, CRIME AND ACCIDENT SCENES (U.S. CLS. 100, 103 AND 106).  
FIRST USE 10-0-2010; IN COMMERCE 10-0-2010.  
PAM WILLIS, EXAMINING ATTORNEY

---

SN 85-158,512. GLOBAL FACILITIES SERVICES CORPORATION, PORTLAND, OR. FILED 10-21-2010.



NO CLAIM IS MADE TO THE EXCLUSIVE RIGHT TO USE "FACILITIES SERVICES CORPORATION", APART FROM THE MARK AS SHOWN.

THE MARK CONSISTS OF THE TEXT "GLOBALFSC" WITH THE "FSC" IN A SLIGHTLY SMALLER SIZE WITH THE TEXT OF "FACILITIES SERVICES CORPORATION" UNDERNEATH SEPARATED BY A LINE, AND TO THE LEFT OF THE TEXT, THERE ARE THREE INTERWOVEN CIRCLES WITH TWO LEAVES ON A SMALL BRANCH INSIDE THE THREE CIRCLES.

**CLASS 37—CONSTRUCTION AND REPAIR**

FOR JANITORIAL SERVICES; PAINTING IN THE FIELD OF COMMERCIAL STRUCTURES; PRESSURE WASHING SERVICES (U.S. CLS. 100, 103 AND 106).  
FIRST USE 9-27-2010; IN COMMERCE 9-27-2010.

**CLASS 44—MEDICAL, BEAUTY AND AGRICULTURAL SERVICES**

FOR LANDSCAPE GARDENING (U.S. CLS. 100 AND 101).  
FIRST USE 9-27-2010; IN COMMERCE 9-27-2010.  
DOUGLAS LEE, EXAMINING ATTORNEY

---

SN 85-158,721. CMC ENERGY SERVICES, INC., BETHESDA, MD. FILED 10-22-2010.

# HOME TUNE-UP

THE MARK CONSISTS OF STANDARD CHARACTERS WITHOUT CLAIM TO ANY PARTICULAR FONT, STYLE, SIZE, OR COLOR.

OWNER OF U.S. REG. NO. 2,858,629.  
NO CLAIM IS MADE TO THE EXCLUSIVE RIGHT TO USE "HOME", APART FROM THE MARK AS SHOWN.

**CLASS 9—ELECTRICAL AND SCIENTIFIC APPARATUS**

FOR COMPUTER SOFTWARE USED TO COLLECT DATA FOR EXISTING HOMES IN ORDER TO IDENTIFY THE GROUP OF IMPROVEMENTS THAT COST LESS ON A YEARLY BASIS WHEN FINANCED THAN THE RESULTING SAVINGS ON ENERGY BILLS; COMPUTER SOFTWARE USED TO ANALYZE DATA TO DETERMINE SAVINGS AND COSTS FOR THE GROUP OF IMPROVEMENTS BASED ON A WHOLE HOUSE CALCULATION WHICH TAKES INTO ACCOUNT THE INTERRELATIONSHIP OF ALL FEATURES TO BE IMPROVED; COMPUTER SOFTWARE USED TO REPORT THE ESTIMATED SAVINGS, COSTS AND PAY-BACK FOR THE IMPROVEMENTS THAT ARE NOT ELIGIBLE TO BE INCLUDED IN THE AFOREMENTIONED GROUP; COMPUTER SOFTWARE USED TO PRINT A DETAILED REPORT EXPLAINING EACH RECOMMENDATION AND OTHER INFORMATION FOR OBTAINING QUALIFIED CONTRACTORS AND LONG-TERM LOW INTEREST FINANCING (U.S. CLS. 21, 23, 26, 36 AND 38).

**CLASS 35—ADVERTISING AND BUSINESS**

FOR ENERGY AUDITING (U.S. CLS. 100, 101 AND 102).

**CLASS 37—CONSTRUCTION AND REPAIR**

FOR INSTALLATION OF WEATHERIZATION, LIGHTING, SEALANT, THERMOSTATS, METERING, AND CONTROLS TO ENHANCE ENERGY EFFICIENCY (U.S. CLS. 100, 103 AND 106).

CHRISTINE MARTIN, EXAMINING ATTORNEY

---

SN 85-158,739. AIR SYSTEM COMPONENTS, INC., RICHARDSON, TX. FILED 10-22-2010.

# EOS

THE MARK CONSISTS OF STANDARD CHARACTERS WITHOUT CLAIM TO ANY PARTICULAR FONT, STYLE, SIZE, OR COLOR.

**CLASS 6—METAL GOODS**

FOR DUCTS AND DUCT CONNECTORS OF METAL FOR AIR CONDITIONING INSTALLATIONS (U.S. CLS. 2, 12, 13, 14, 23, 25 AND 50).

**CLASS 9—ELECTRICAL AND SCIENTIFIC APPARATUS**

FOR SOUND ATTENUATORS (U.S. CLS. 21, 23, 26, 36 AND 38).

**CLASS 11—ENVIRONMENTAL CONTROL APPARATUS**

FOR AIR CONDITIONING SYSTEMS COMPRISING GRILLES, REGISTERS, DIFFUSERS, VOLUME CONTROL DAMPERS, NON-RETURN DAMPERS, BACK DRAFT DAMPERS, GRAVITY SHUTTERS, LOUVERS, SAND TRAP LOUVERS, VARIABLE AIR VALVES, FAN COIL UNITS, FIRE DAMPERS, MOTORIZED SMOKE AND FIRE DAMPERS, JET NOZZLES AND SWIRL DIFFUSERS (U.S. CLS. 13, 21, 23, 31 AND 34).

**CLASS 19—NON-METALLIC BUILDING MATERIALS**

FOR NON-METAL FLEXIBLE DUCTS AND DUCT CONNECTORS FOR AIR CONDITIONING INSTALLATIONS (U.S. CLS. 1, 12, 33 AND 50).

TARAH HARDY, EXAMINING ATTORNEY

SN 85-158,810. REFINERY TERMINAL FIRE COMPANY, CORPUS CHRISTI, TX. FILED 10-22-2010.

---

RTFC

THE MARK CONSISTS OF STANDARD CHARACTERS WITHOUT CLAIM TO ANY PARTICULAR FONT, STYLE, SIZE, OR COLOR.

**CLASS 41—EDUCATION AND ENTERTAINMENT**

FOR TRAINING SERVICES IN THE FIELD OF INDUSTRIAL FIRE FIGHTING (U.S. CLS. 100, 101 AND 107).

FIRST USE 8-31-1994; IN COMMERCE 1-31-1995.

**CLASS 45—PERSONAL AND LEGAL SERVICES**

FOR FIRE FIGHTING SERVICES (U.S. CLS. 100 AND 101).

FIRST USE 11-30-1970; IN COMMERCE 6-1-1998.  
JAY BESCH, EXAMINING ATTORNEY

---

SN 85-159,228. PERFECT SYNERGY MEDIA, LLC, FRESNO, CA. FILED 10-22-2010.

AUTO CHASER

THE MARK CONSISTS OF STANDARD CHARACTERS WITHOUT CLAIM TO ANY PARTICULAR FONT, STYLE, SIZE, OR COLOR.

NO CLAIM IS MADE TO THE EXCLUSIVE RIGHT TO USE "AUTO", APART FROM THE MARK AS SHOWN.

**CLASS 16—PAPER GOODS AND PRINTED MATTER**

FOR PRINTED PERIODICALS FEATURING ADVERTISEMENTS OF VEHICLES, VEHICLE PARTS AND ACCESSORIES, AND VEHICLE SERVICES (U.S. CLS. 2, 5, 22, 23, 29, 37, 38 AND 50).

FIRST USE 1-5-2011; IN COMMERCE 1-5-2011.

**CLASS 35—ADVERTISING AND BUSINESS**

FOR ADVERTISING AND MARKETING SERVICES, NAMELY, PROMOTING THE GOODS AND SERVICES OF OTHERS; ADVERTISING SERVICES, NAMELY, PROVIDING ADVERTISING SPACE IN A PERIODICAL; ADVERTISING SERVICES, NAMELY, PROVIDING ADVERTISING SPACE ON A WEBSITE; PREPARING ADVERTISEMENTS FOR OTHERS; PROVIDING CONSUMER INFORMATION ABOUT VEHICLES, VEHICLE PARTS AND ACCESSORIES, AND VEHICLE SERVICES VIA A GLOBAL COMPUTER NETWORK (U.S. CLS. 100, 101 AND 102).

FIRST USE 1-5-2011; IN COMMERCE 1-5-2011.  
DOUGLAS LEE, EXAMINING ATTORNEY

---

SN 85-159,324. CORPORATE CASUALS, LLC, CONCORD, MA. FILED 10-22-2010.

ITSHIRT

THE MARK CONSISTS OF STANDARD CHARACTERS WITHOUT CLAIM TO ANY PARTICULAR FONT, STYLE, SIZE, OR COLOR.

**CLASS 9—ELECTRICAL AND SCIENTIFIC APPARATUS**

FOR SOFTWARE APPLICATION TO ALLOW USERS TO ACCESS AN ON-LINE STORE TO PURCHASE CLOTHING (U.S. CLS. 21, 23, 26, 36 AND 38).

**CLASS 25—CLOTHING**

FOR CLOTHING, NAMELY, SHIRTS AND SWEAT SHIRTS (U.S. CLS. 22 AND 39).

**CLASS 35—ADVERTISING AND BUSINESS**

FOR ONLINE RETAIL STORE SERVICES FEATURING CUSTOMIZED CLOTHING; PROVIDING INCENTIVE AWARDS PROGRAMS FOR CUSTOMERS FOR REFERRALS AND PURCHASES FEATURING ISSUANCE AND PROCESSING OF REWARD POINTS FOR PURCHASE AND REFERRALS FOR ONLINE PURCHASE OF CLOTHING (U.S. CLS. 100, 101 AND 102).

PATRICIA EVANKO, EXAMINING ATTORNEY

---

SN 85-159,399. KOON, JONATHAN, DOUGLSTON, NY. FILED 10-22-2010.

PRIVATE  STOCK

OWNER OF U.S. REG. NO. 3,847,455.  
THE MARK CONSISTS OF THE WORDS "PRIVATE STOCK" WITH A TWICE ENCIRCLED AND POINTED GREEK CROSS DESIGN IN BETWEEN THESE TWO WORDS.

**CLASS 9—ELECTRICAL AND SCIENTIFIC APPARATUS**

FOR BACKPACKS ESPECIALLY ADAPTED FOR HOLDING LAPTOPS AND NOTEBOOK COMPUTERS; CARRYING CASES FOR CELL PHONES; CARRYING CASES FOR MOBILE COMPUTERS; COMPUTER BAGS; LAPTOP CARRYING CASES; PROTECTIVE COVERS AND CASES FOR CELL PHONES, LAPTOPS AND PORTABLE MEDIA PLAYERS (U.S. CLS. 21, 23, 26, 36 AND 38).

**CLASS 14—JEWELRY**

FOR BRACELETS; DRESS WATCHES; EARRINGS; JEWELRY WATCHES; NECKLACES; RINGS; WATCHES (U.S. CLS. 2, 27, 28 AND 50).

**CLASS 18—LEATHER GOODS**

FOR BACKPACKS; BELT BAGS AND HIP BAGS; DUFFLE BAGS; HANDBAGS; LUGGAGE; PURSES AND WALLETS; TRAVEL CASES (U.S. CLS. 1, 2, 3, 22 AND 41).

**CLASS 25—CLOTHING**

FOR BLOUSES; BRIEFS; CAPS; COATS; DENIM JACKETS; HATS; JACKETS; JEANS; SCARVES; SHIRTS; SKIRTS; SKIRTS AND DRESSES; SOCKS; SWEAT PANTS; SWEAT SHIRTS; SWEATERS; T-SHIRTS; TEE SHIRTS; UNDERGARMENTS; UNDERWEAR; VESTS (U.S. CLS. 22 AND 39).

SHAUNIA CARLYLE, EXAMINING ATTORNEY

SN 85-160,935. PROGNOSYS BIOSCIENCES, INC, LA JOLLA, CA. FILED 10-26-2010.

**RIVIA**

THE MARK CONSISTS OF STANDARD CHARACTERS WITHOUT CLAIM TO ANY PARTICULAR FONT, STYLE, SIZE, OR COLOR.

**CLASS 1—CHEMICALS**

FOR REAGENTS FOR CHEMICAL ANALYSES; REAGENTS FOR USE IN SCIENTIFIC APPARATUS FOR BIOLOGICAL ANALYSIS; AND BIOCHEMICAL REAGENTS USED FOR NON-MEDICAL PURPOSES (U.S. CLS. 1, 5, 6, 10, 26 AND 46).

**CLASS 9—ELECTRICAL AND SCIENTIFIC APPARATUS**

FOR APPARATUS, INSTRUMENTS AND KITS FOR ANALYSIS OF BIOLOGICAL, BIOCHEMICAL OR CHEMICAL MATERIALS, NAMELY, LABORATORY INSTRUMENT FOR THE DETECTION OF GENETIC SEQUENCES AND SEQUENCE VARIATIONS IN A BIOLOGICAL SAMPLE FOR RESEARCH USE; COMPUTER SOFTWARE AND DATA PROCESSORS FOR USE IN THE ANALYSIS OF BIOLOGICAL, BIOCHEMICAL OR CHEMICAL MATERIALS (U.S. CLS. 21, 23, 26, 36 AND 38).

**CLASS 42—SCIENTIFIC AND COMPUTER SERVICES**

FOR BIOLOGICAL, BIOCHEMICAL, OR CHEMICAL RESEARCH (U.S. CLS. 100 AND 101).

INGRID C. EULIN, EXAMINING ATTORNEY

SN 85-163,351. CORE EDUCATION AND CONSULTING SOLUTIONS, INC., ATLANTA, GA. FILED 10-28-2010.

**CORE ECS BRIGHT IDEA**

THE MARK CONSISTS OF STANDARD CHARACTERS WITHOUT CLAIM TO ANY PARTICULAR FONT, STYLE, SIZE, OR COLOR.

OWNER OF U.S. REG. NOS. 3,350,912, 3,350,913 AND 3,725,967.

**CLASS 9—ELECTRICAL AND SCIENTIFIC APPARATUS**

FOR COMPUTER SOFTWARE FOR USE IN DATA AND DATABASE MANAGEMENT AND LEGAL COMPLIANCE IN THE FIELD OF SPECIAL EDUCATION AND CHILD CARE, AND USER MANUALS SOLD THEREWITH AS A UNIT (U.S. CLS. 21, 23, 26, 36 AND 38).

**CLASS 35—ADVERTISING AND BUSINESS**

FOR DATA MANAGEMENT SERVICES, NAMELY, COMPUTERIZED DATABASE MANAGEMENT (U.S. CLS. 100, 101 AND 102).

**CLASS 42—SCIENTIFIC AND COMPUTER SERVICES**

FOR COMPUTER SERVICES, NAMELY, PROVIDING ON-LINE NON-DOWNLOADABLE SOFTWARE ON A GLOBAL COMPUTER NETWORK FOR USE IN DATA AND DATABASE MANAGEMENT AND LEGAL COMPLIANCE IN THE FIELD OF SPECIAL EDUCATION AND CHILD CARE; APPLICATION SERVICE PROVIDER (ASP) FEATURING SOFTWARE FOR USE IN DATA AND DATABASE MANAGEMENT AND LEGAL COMPLIANCE IN THE FIELD OF SPECIAL EDUCATION AND CHILD CARE; DESIGN, DEVELOPMENT AND IMPLEMENTATION OF SOFTWARE FOR USE IN DATA AND DATABASE MANAGEMENT AND LEGAL COMPLIANCE IN THE FIELD OF SPECIAL EDUCATION AND CHILD CARE; DEVELOPMENT OF SOFTWARE FOR USE IN DATA AND DATABASE MANAGEMENT AND LEGAL COMPLIANCE IN THE FIELD OF SPECIAL EDUCATION AND CHILD CARE; COMPUTER SOFTWARE CONSULTING IN THE FIELD OF SOFTWARE FOR USE IN DATA AND DATABASE MANAGEMENT AND LEGAL COMPLIANCE IN THE FIELD OF SPECIAL EDUCATION AND CHILD CARE; DATABASE DEVELOPMENT SERVICES; COMPUTER SOFTWARE DEVELOPMENT; DATA WAREHOUSING; DESIGN, DEVELOPMENT AND IMPLEMENTATION OF SOFTWARE (U.S. CLS. 100 AND 101).

EDWARD NELSON, EXAMINING ATTORNEY

SN 85-163,657. CORE EDUCATION AND CONSULTING SOLUTIONS, INC., ATLANTA, GA. FILED 10-28-2010.



OWNER OF U.S. REG. NOS. 3,350,913 AND 3,725,967.  
THE MARK CONSISTS OF "ECSDTOOL, QUERYANY-DATAANYWHERE!" AND THE LETTER "T" IS FORMED BY A THUMB TACK AND THE UNDERSIDE OF THE "T" HAS A SPARK EMANATING FROM THE LETTER "T".

#### CLASS 9—ELECTRICAL AND SCIENTIFIC APPARATUS

FOR COMPUTER SOFTWARE TO AUTOMATE DATA WAREHOUSING AND FOR USE IN DATABASE MANAGEMENT IN THE FIELD OF BUSINESS INFORMATION (U.S. CLS. 21, 23, 26, 36 AND 38).

#### CLASS 35—ADVERTISING AND BUSINESS

FOR COMPUTERIZED DATABASE MANAGEMENT (U.S. CLS. 100, 101 AND 102).

#### CLASS 42—SCIENTIFIC AND COMPUTER SERVICES

FOR PROVIDING TEMPORARY USE OF ON-LINE NON-DOWNLOADABLE SOFTWARE TO AUTOMATE DATA WAREHOUSING AND FOR USE IN DATABASE MANAGEMENT IN THE FIELD OF BUSINESS INFORMATION (U.S. CLS. 100 AND 101).

EDWARD NELSON, EXAMINING ATTORNEY

---

SN 85-164,208. RUSTICI, ROBERT D., ST. AUGUSTINE, FL. FILED 10-28-2010.



THE MARK CONSISTS OF THE STYLIZED WORDING "SALTY PALMS" WITH A PALM TREE WHERE THE PALMS ARE DEPICTED BY FISH AND A FISHING HOOK FOR THE TRUNK.

#### CLASS 16—PAPER GOODS AND PRINTED MATTER

FOR DECALS (U.S. CLS. 2, 5, 22, 23, 29, 37, 38 AND 50).  
FIRST USE 7-10-2008; IN COMMERCE 7-10-2008.

#### CLASS 25—CLOTHING

FOR HATS; SHIRTS (U.S. CLS. 22 AND 39).  
FIRST USE 7-10-2008; IN COMMERCE 7-10-2008.  
BRIDGETT SMITH, EXAMINING ATTORNEY

SN 85-165,055. SUN PRODUCTS CORPORATION, THE, WILTON, CT. FILED 10-29-2010.



OWNER OF U.S. REG. NOS. 1,246,754, 2,717,343 AND OTHERS.

THE STIPPLING IS FOR SHADING PURPOSES ONLY.

THE MARK CONSISTS OF A BEAR HOLDING A TOWEL OR BLANKET THAT ACTS AS A BANNER IN FRONT OF THE BEAR. THE STYLIZED WORDING "SNUGGLE" APPEARS ON THE FRONT OF THE TOWEL OR BLANKET.

#### CLASS 3—COSMETICS AND CLEANING PREPARATIONS

FOR HOME FRAGRANCE PRODUCTS, NAMELY, POTPOURRI, FRAGRANCE OILS, FRAGRANCE SPRAYS, AND FRAGRANCE GELS FOR HOUSEHOLD USE (U.S. CLS. 1, 4, 6, 50, 51 AND 52).

#### CLASS 5—PHARMACEUTICALS

FOR AIR FRESHENERS AND AIR FRESHENER REFILLS (U.S. CLS. 6, 18, 44, 46, 51 AND 52).

#### CLASS 11—ENVIRONMENTAL CONTROL APPARATUS

FOR ELECTRICALLY OPERATED HOME FRAGRANCE DIFFUSERS (U.S. CLS. 13, 21, 23, 31 AND 34).  
ANDREA HACK, EXAMINING ATTORNEY

---

SN 85-165,487. DOMINANT BRANDS LLC, BAYSIDE, NY. FILED 10-30-2010.



FIRST BOSTON

NO CLAIM IS MADE TO THE EXCLUSIVE RIGHT TO USE "FIRST BOSTON", APART FROM THE MARK AS SHOWN.

THE MARK CONSISTS OF A STYLIZED SHIP DESIGN ENCLOSED IN A SOLID CIRCLE WITH TRANSPARENT HORIZONTAL STRIPES FOLLOWED BY THE TERM "FIRST BOSTON" IN A STYLIZED FONT.

**CLASS 35—ADVERTISING AND BUSINESS**

FOR COMMERCIAL BUSINESS MANAGEMENT, BUSINESS ADMINISTRATION CONSULTANCY, CONSULTING IN THE FIELDS OF BUSINESS ORGANIZATION AND MANAGEMENT, BUSINESS INTERMEDIARY SERVICES AND ADVISORY SERVICES IN THE FIELD OF SELLING PRODUCTS AND RENDERING SERVICES; ACCOUNTING FOR THIRD PARTIES; ECONOMIC FORECASTING AND ANALYSIS; PROVIDING BUSINESS INFORMATION, DATA, STATISTICS, AND INDICES FOR OTHERS; PROVIDING STATISTICAL INFORMATION FOR BUSINESSES; PROVIDING TRADE AND BUSINESS PRICE INFORMATION FOR BUSINESSES; PERSONNEL MANAGEMENT, HUMAN CAPITAL MANAGEMENT OUTSOURCING, ORGANIZING AND CONDUCTING TRADE FAIRS AND EXHIBITIONS FOR ECONOMIC AND ADVERTISING PURPOSES, ARRANGING AND CONDUCTING AUCTION SALES (U.S. CLS. 100, 101 AND 102).

**CLASS 36—INSURANCE AND FINANCIAL**

FOR INVESTMENT BANKING SERVICES, FINANCIAL ADVISORY SERVICES, FINANCIAL MANAGEMENT, AND INVESTMENT ADVISORY SERVICES AND SECURITIES BROKERAGE SERVICES (U.S. CLS. 100, 101 AND 102).

DAVID C. REIHNER, EXAMINING ATTORNEY

SN 85-165,602. INTEMATIX CORPORATION, FREMONT, CA. FILED 10-30-2010.

# ChromaLit

THE MARK CONSISTS OF STANDARD CHARACTERS WITHOUT CLAIM TO ANY PARTICULAR FONT, STYLE, SIZE, OR COLOR.

**CLASS 1—CHEMICALS**

FOR CHEMICALS, NAMELY, PHOSPHORS AND SCINTILLATORS, NAMELY, A SUBSTANCE THAT GLOWS WHEN HIT BY A HIGH ENERGY PARTICLE (U.S. CLS. 1, 5, 6, 10, 26 AND 46).

**CLASS 11—ENVIRONMENTAL CONTROL APPARATUS**

FOR LED (LIGHT EMITTING DIODE) LIGHTING FIXTURES; LED LIGHT BULBS (U.S. CLS. 13, 21, 23, 31 AND 34).

EDWARD NELSON, EXAMINING ATTORNEY

SN 85-166,020. AMERICAN EXPRESS MARKETING & DEVELOPMENT CORP., NEW YORK, NY. FILED 11-1-2010.

# EUROPE IP ZONE

THE MARK CONSISTS OF STANDARD CHARACTERS WITHOUT CLAIM TO ANY PARTICULAR FONT, STYLE, SIZE, OR COLOR.

OWNER OF U.S. REG. NO. 3,607,783.

NO CLAIM IS MADE TO THE EXCLUSIVE RIGHT TO USE "EUROPE IP", APART FROM THE MARK AS SHOWN.

**CLASS 35—ADVERTISING AND BUSINESS**

FOR PROVIDING A DATABASE FEATURING INTELLECTUAL PROPERTY RIGHTS AVAILABLE FOR POSSIBLE ACQUISITION; PROVIDING ELECTRONIC TRACKING OF INTELLECTUAL PROPERTY ASSETS TO OTHERS (U.S. CLS. 100, 101 AND 102).

**CLASS 36—INSURANCE AND FINANCIAL**

FOR INTELLECTUAL PROPERTY VALUATION SERVICES (U.S. CLS. 100, 101 AND 102).

**CLASS 45—PERSONAL AND LEGAL SERVICES**

FOR LICENSING OF INTELLECTUAL PROPERTY; PROVIDING INFORMATION ABOUT INTELLECTUAL PROPERTY RIGHTS (U.S. CLS. 100 AND 101).

GILBERT SWIFT, EXAMINING ATTORNEY

SN 85-166,027. AMERICAN EXPRESS MARKETING & DEVELOPMENT CORP., NEW YORK, NY. FILED 11-1-2010.

# EUROPEAN IP ZONE

THE MARK CONSISTS OF STANDARD CHARACTERS WITHOUT CLAIM TO ANY PARTICULAR FONT, STYLE, SIZE, OR COLOR.

OWNER OF U.S. REG. NO. 3,607,783.

NO CLAIM IS MADE TO THE EXCLUSIVE RIGHT TO USE "EUROPEAN IP", APART FROM THE MARK AS SHOWN.

**CLASS 35—ADVERTISING AND BUSINESS**

FOR PROVIDING A DATABASE FEATURING INTELLECTUAL PROPERTY RIGHTS AVAILABLE FOR POSSIBLE ACQUISITION; PROVIDING ELECTRONIC TRACKING OF INTELLECTUAL PROPERTY ASSETS TO OTHERS (U.S. CLS. 100, 101 AND 102).

**CLASS 36—INSURANCE AND FINANCIAL**

FOR INTELLECTUAL PROPERTY VALUATION SERVICES (U.S. CLS. 100, 101 AND 102).

**CLASS 45—PERSONAL AND LEGAL SERVICES**

FOR LICENSING OF INTELLECTUAL PROPERTY; PROVIDING INFORMATION ABOUT INTELLECTUAL PROPERTY RIGHTS (U.S. CLS. 100 AND 101).

GILBERT SWIFT, EXAMINING ATTORNEY

SN 85-166,034. AMERICAN EXPRESS MARKETING & DEVELOPMENT CORP., NEW YORK, NY. FILED 11-1-2010.

SN 85-167,903. K-G PACKAGING, INC., CONCORD, ONTARIO, CANADA, FILED 11-3-2010.

## IP ZONE EUROPE

THE MARK CONSISTS OF STANDARD CHARACTERS WITHOUT CLAIM TO ANY PARTICULAR FONT, STYLE, SIZE, OR COLOR.

OWNER OF U.S. REG. NO. 3,607,783.

NO CLAIM IS MADE TO THE EXCLUSIVE RIGHT TO USE "IP" AND "EUROPE", APART FROM THE MARK AS SHOWN.

### CLASS 35—ADVERTISING AND BUSINESS

FOR PROVIDING A DATABASE FEATURING INTELLECTUAL PROPERTY RIGHTS AVAILABLE FOR POSSIBLE ACQUISITION; PROVIDING ELECTRONIC TRACKING OF INTELLECTUAL PROPERTY ASSETS TO OTHERS (U.S. CLS. 100, 101 AND 102).

### CLASS 36—INSURANCE AND FINANCIAL

FOR INTELLECTUAL PROPERTY VALUATION SERVICES (U.S. CLS. 100, 101 AND 102).

### CLASS 45—PERSONAL AND LEGAL SERVICES

FOR LICENSING OF INTELLECTUAL PROPERTY; PROVIDING INFORMATION ABOUT INTELLECTUAL PROPERTY RIGHTS (U.S. CLS. 100 AND 101).  
GILBERT SWIFT, EXAMINING ATTORNEY

---

SN 85-167,508. INTERMOUNTAIN POWER AGENCY, WEST JORDAN, UT. FILED 11-2-2010.

## INTERMOUNTAIN POWER AGENCY

THE MARK CONSISTS OF STANDARD CHARACTERS WITHOUT CLAIM TO ANY PARTICULAR FONT, STYLE, SIZE, OR COLOR.

NO CLAIM IS MADE TO THE EXCLUSIVE RIGHT TO USE "POWER AGENCY", APART FROM THE MARK AS SHOWN.

### CLASS 39—TRANSPORTATION AND STORAGE

FOR ELECTRICITY DISTRIBUTION (U.S. CLS. 100 AND 105).  
FIRST USE 0-0-1987; IN COMMERCE 0-0-1987.

### CLASS 40—MATERIAL TREATMENT

FOR GENERATION OF ELECTRICITY (U.S. CLS. 100, 103 AND 106).  
FIRST USE 0-0-1987; IN COMMERCE 0-0-1987.  
JACQUELINE A. LAVINE, EXAMINING ATTORNEY



PRIORITY CLAIMED UNDER SEC. 44(D) ON CANADA APPLICATION NO. 1479429, FILED 5-3-2010.

### CLASS 1—CHEMICALS

FOR AUTOMOTIVE CHEMICAL PRODUCTS, NAMELY, STARTING FLUIDS, IGNITION SPRAY, BATTERY ACID NEUTRALIZER, LOCK DE-ICER; MOULD-RELEASE PREPARATIONS; ANTI-STATIC SPRAY FOR ELECTRONIC EQUIPMENT; SPRAY ADHESIVES FOR INDUSTRIAL PURPOSES (U.S. CLS. 1, 5, 6, 10, 26 AND 46).

### CLASS 2—PAINTS

FOR AUTOMOTIVE COATINGS AND SPRAYS, NAMELY, AUTOMOTIVE UNDERCOATING, ANTI-RUST SPRAY, CHIP AND STONE GUARD AND COLD GALVANIZED COATING; ANTI-TARNISH SPRAY, NAMELY, ANTI-TARNISHING PREPARATIONS FOR COATING METALS (U.S. CLS. 6, 11 AND 16).

### CLASS 3—COSMETICS AND CLEANING PREPARATIONS

FOR AUTOMOTIVE CLEANING PRODUCTS, NAMELY, ENGINE CLEANER, GLASS CLEANER, BATTERY CLEANER, BRAKE PARTS CLEANER, DEGREASER, CARBURETOR AND CHOKE CLEANER, RUG SHAMPOO, UPHOLSTERY SHAMPOO AND SALT REMOVER; HOME AND HARDWARE CLEANING PRODUCTS, NAMELY, GLASS CLEANER, FURNITURE WAX, FURNITURE POLISH, STAIN REMOVER, PAINT REMOVER, CONTACT CLEANER, NAMELY, ELECTRICAL CONTACT CLEANER, GUM REMOVER, ANTI-STATIC SPRAY FOR HOUSEHOLD PURPOSES, ANTI-SLIP SPRAY LIQUIDS FOR FLOORS, RUG SHAMPOO, SPOT REMOVER, STAINLESS STEEL CLEANER, GLASS CLEANER; INDUSTRIAL CLEANING PRODUCTS, NAMELY, MOULD DIE CLEANER, TOOL AND PARTS CLEANER, AND AIR DUSTERS, NAMELY, COMPRESSED AIR IN CANS FOR DUSTING; SHOE CARE PRODUCTS, NAMELY, AEROSOL PROTECTIVE SPRAY AND SHOE CLEANER (U.S. CLS. 1, 4, 6, 50, 51 AND 52).

### CLASS 4—LUBRICANTS AND FUELS

FOR AUTOMOTIVE PRODUCTS, NAMELY, PENETRATING OIL, NON-SILICONE LUBRICANT, SILICONE LUBRICANT, LITHIUM GREASE; INDUSTRIAL PRODUCTS, NAMELY, CHAIN LUBRICANT, BELT DRESSING, NON-SILICONE LUBRICANT AND SILICONE LUBRICANT (U.S. CLS. 1, 6 AND 15).

### CLASS 5—PHARMACEUTICALS

FOR HOME AND HARDWARE PRODUCTS, NAMELY, ALL-PURPOSE DISINFECTANT, ROOM DEODORANT AND INSECTICIDE; INDUSTRIAL PRODUCTS, NAMELY, ALL-PURPOSE DISINFECTANT, AIR FRESHENER AND INSECTICIDE; SHOE PRODUCTS, NAMELY, DEODORIZER AND DISINFECTANT SPRAY; SKIN BARRIER SPRAY, NAMELY, BARRIER LOTION FOR PROTECTION FROM TOXIC OILS OF POISONOUS PLANTS (U.S. CLS. 6, 18, 44, 46, 51 AND 52).  
RONALD MCMORROW, EXAMINING ATTORNEY



SN 85-169,679. MACY'S MERCHANDISING GROUP, INC.,  
NEW YORK, NY. FILED 11-4-2010.

## JENNI BY JENNIFER MOORE

THE MARK CONSISTS OF STANDARD CHARACTERS  
WITHOUT CLAIM TO ANY PARTICULAR FONT, STYLE,  
SIZE, OR COLOR.

OWNER OF U.S. REG. NO. 1,410,686.  
THE NAME "JENNIFER MOORE" DOES NOT IDENTIFY  
A LIVING INDIVIDUAL.

### CLASS 20—FURNITURE AND ARTICLES NOT OTHERWISE CLASSIFIED

FOR DECORATIVE PILLOWS (U.S. CLS. 2, 13, 22, 25,  
32 AND 50).  
FIRST USE 10-0-2010; IN COMMERCE 10-0-2010.

### CLASS 24—FABRICS

FOR BLANKETS; BLANKET SETS COMPRISED OF  
BLANKETS AND SLEEP MASKS SOLD TOGETHER AS  
A UNIT (U.S. CLS. 42 AND 50).  
FIRST USE 10-0-2010; IN COMMERCE 10-0-2010.

### CLASS 25—CLOTHING

FOR BRAS, CHEMISES, HOODED SWEATSHIRTS,  
PAJAMA PANTS, PAJAMA SHORTS, PAJAMA TOPS,  
PANTS, PANTYHOSE, ROBES, SKIRTS, SLEEPWEAR,  
SLIPPERS, SOCKS, SWEAT SHIRTS, TANKS, T-SHIRTS  
(U.S. CLS. 22 AND 39).  
FIRST USE 10-0-2004; IN COMMERCE 10-0-2004.

JANICE L. MCMORROW, EXAMINING ATTORNEY

SN 85-170,319. MEMIA LIMITED, CHRISTCHURCH, NEW  
ZEALAND, FILED 11-5-2010.

# MEMIA

THE MARK CONSISTS OF STANDARD CHARACTERS  
WITHOUT CLAIM TO ANY PARTICULAR FONT, STYLE,  
SIZE, OR COLOR.

OWNER OF NEW ZEALAND REG. NO. 808341, DATED 6-  
23-2009, EXPIRES 6-23-2016.  
OWNER OF U.S. REG. NO. 3,852,721.

### CLASS 35—ADVERTISING AND BUSINESS

FOR BUSINESS MANAGEMENT CONSULTANCY;  
BUSINESS ORGANIZATION CONSULTANCY (U.S.  
CLS. 100, 101 AND 102).

### CLASS 42—SCIENTIFIC AND COMPUTER SERVICES

FOR COMPUTER SERVICES, NAMELY, REMOTE  
MANAGEMENT OF COMPUTER APPLICATIONS FOR  
OTHERS; COMPUTER SERVICES, NAMELY, REMOTE  
AND ON-SITE MANAGEMENT OF THE INFORMATION  
TECHNOLOGY (IT) SYSTEMS OF OTHERS; COMPUTER  
SYSTEM DESIGN SERVICES; SOFTWARE DEVELOP-  
MENT SERVICES; SOFTWARE INSTALLATION AND  
MAINTENANCE SERVICES; SOFTWARE DESIGN SER-  
VICES; SOFTWARE CONSULTANCY SERVICES; IN-  
FORMATION TECHNOLOGY CONSULTING SERVICES  
(U.S. CLS. 100 AND 101).

MARK RADEMACHER, EXAMINING ATTORNEY

SN 85-170,660. THIRST, L.C., IOWA CITY, IA. FILED 11-5-  
2010.



THE COLOR(S) GRAY IS/ARE CLAIMED AS A FEATURE  
OF THE MARK.

THE MARK CONSISTS OF THE STYLIZED WORD  
"THIRST" IN THE COLOR GRAY.

### CLASS 9—ELECTRICAL AND SCIENTIFIC APPARATUS

FOR AUTOMATIC VENDING MACHINES; AUTO-  
MATIC VENDING MACHINES AND MECHANISMS  
FOR COIN OPERATED APPARATUS; AUTOMATIC  
VENDING MACHINES AND MECHANISMS FOR  
COIN-OPERATED APPARATUS; COIN-OPERATED  
VENDING MACHINES; VENDING MACHINES (U.S.  
CLS. 21, 23, 26, 36 AND 38).  
FIRST USE 10-25-2010; IN COMMERCE 10-25-2010.

### CLASS 32—LIGHT BEVERAGES

FOR DRINKING WATER; DRINKING WATER WITH  
VITAMINS; DRINKING WATERS; FLAVORED WATERS  
(U.S. CLS. 45, 46 AND 48).

FIRST USE 10-25-2010; IN COMMERCE 10-25-2010.  
VERNA BETH RIRIE, EXAMINING ATTORNEY

SN 85-170,720. SOUND INPATIENT PHYSICIANS, INC.,  
TACOMA, WA. FILED 11-5-2010.

# SOUND PHYSICIANS

THE MARK CONSISTS OF STANDARD CHARACTERS  
WITHOUT CLAIM TO ANY PARTICULAR FONT, STYLE,  
SIZE, OR COLOR.

OWNER OF U.S. REG. NOS. 3,523,270 AND 3,523,272.  
NO CLAIM IS MADE TO THE EXCLUSIVE RIGHT TO  
USE "PHYSICIANS", APART FROM THE MARK AS  
SHOWN.

**CLASS 35—ADVERTISING AND BUSINESS**

FOR MEDICAL PRACTICE MANAGEMENT AND ADMINISTRATION, NAMELY, BUSINESS ADMINISTRATION AND MANAGEMENT FOR MEDICAL PRACTICES; ADVERTISING AND MARKETING SERVICES; CONSUMER AND EMPLOYEE SURVEY SERVICES; HUMAN RESOURCES MANAGEMENT; OPERATION OF TELEPHONE CALL CENTER FOR OTHERS (U.S. CLS. 100, 101 AND 102).

**CLASS 41—EDUCATION AND ENTERTAINMENT**

FOR EDUCATIONAL SERVICES, NAMELY, CONDUCTING CLASSES, SEMINARS, CONFERENCES, WORKSHOPS IN THE FIELDS OF MEDICAL PRACTICE MANAGEMENT AND ADMINISTRATION AND IN-PATIENT MEDICINE AND DISTRIBUTION OF COURSE MATERIAL IN CONNECTION THEREWITH (U.S. CLS. 100, 101 AND 107).

**CLASS 42—SCIENTIFIC AND COMPUTER SERVICES**

FOR PROVIDING TEMPORARY USE OF ONLINE, NON-DOWNLOADABLE SOFTWARE FOR MEDICAL PRACTICE MANAGEMENT AND ADMINISTRATION; PROVIDING TEMPORARY USE OF ONLINE, NON-DOWNLOADABLE SOFTWARE FOR COLLECTING, ORGANIZING, AND ANALYZING INFORMATION IN THE FIELD OF MEDICAL SERVICES (U.S. CLS. 100 AND 101).

**CLASS 44—MEDICAL, BEAUTY AND AGRICULTURAL SERVICES**

FOR MEDICAL SERVICES (U.S. CLS. 100 AND 101).  
VERNA BETH RIRIE, EXAMINING ATTORNEY

SN 85-170,723. SOUND INPATIENT PHYSICIANS, INC., TACOMA, WA. FILED 11-5-2010.



OWNER OF U.S. REG. NOS. 3,523,270 AND 3,523,272.  
NO CLAIM IS MADE TO THE EXCLUSIVE RIGHT TO USE "PHYSICIANS", APART FROM THE MARK AS SHOWN.

THE MARK CONSISTS OF THE DESIGN OF THE SUN OVER THE WORDS "SOUND PHYSICIANS".

**CLASS 35—ADVERTISING AND BUSINESS**

FOR MEDICAL PRACTICE MANAGEMENT AND ADMINISTRATION, NAMELY, BUSINESS ADMINISTRATION AND MANAGEMENT FOR MEDICAL PRACTICES; ADVERTISING AND MARKETING SERVICES; CONSUMER AND EMPLOYEE SURVEY SERVICES; HUMAN RESOURCES MANAGEMENT; OPERATION OF TELEPHONE CALL CENTER FOR OTHERS (U.S. CLS. 100, 101 AND 102).

**CLASS 41—EDUCATION AND ENTERTAINMENT**

FOR EDUCATIONAL SERVICES, NAMELY, CONDUCTING CLASSES, SEMINARS, CONFERENCES, WORKSHOPS IN THE FIELDS OF MEDICAL PRACTICE MANAGEMENT AND ADMINISTRATION AND IN-PATIENT MEDICINE AND DISTRIBUTION OF COURSE MATERIAL IN CONNECTION THEREWITH (U.S. CLS. 100, 101 AND 107).

**CLASS 42—SCIENTIFIC AND COMPUTER SERVICES**

FOR PROVIDING TEMPORARY USE OF ONLINE, NON-DOWNLOADABLE SOFTWARE FOR MEDICAL PRACTICE MANAGEMENT AND ADMINISTRATION; PROVIDING TEMPORARY USE OF ONLINE, NON-DOWNLOADABLE SOFTWARE FOR COLLECTING, ORGANIZING, AND ANALYZING INFORMATION IN THE FIELD OF MEDICAL SERVICES (U.S. CLS. 100 AND 101).

**CLASS 44—MEDICAL, BEAUTY AND AGRICULTURAL SERVICES**

FOR MEDICAL SERVICES (U.S. CLS. 100 AND 101).  
VERNA BETH RIRIE, EXAMINING ATTORNEY

SN 85-171,845. CROWN WORTHY, BRONX, NY. FILED 11-8-2010.

**CROWN WORTHY**

THE MARK CONSISTS OF STANDARD CHARACTERS WITHOUT CLAIM TO ANY PARTICULAR FONT, STYLE, SIZE, OR COLOR.

**CLASS 3—COSMETICS AND CLEANING PREPARATIONS**

FOR HAIR CARE PRODUCTS, NAMELY, SHAMPOO, CONDITIONER, HAIR STYLING PREPARATIONS (U.S. CLS. 1, 4, 6, 50, 51 AND 52).

**CLASS 44—MEDICAL, BEAUTY AND AGRICULTURAL SERVICES**

FOR COSMETOLOGY SERVICES (U.S. CLS. 100 AND 101).  
FIRST USE 10-26-2010; IN COMMERCE 10-26-2010.  
KEVON CHISOLM, EXAMINING ATTORNEY

SN 85-172,289. RESPITE—LINK, CORP., ALOHA, OR. FILED 11-9-2010.

**RECIPROTY**

THE MARK CONSISTS OF STANDARD CHARACTERS WITHOUT CLAIM TO ANY PARTICULAR FONT, STYLE, SIZE, OR COLOR.

**CLASS 35—ADVERTISING AND BUSINESS**

FOR BARTER EXCHANGE SERVICES, NAMELY, PROVIDING COMMERCIAL BARTER AND TRADE EXCHANGE OF PRODUCTS AND SERVICES VIA A GLOBAL COMPUTER INFORMATION NETWORK; MATCHING CONSUMERS WITH PROFESSIONALS IN THE FIELD OF RESIDENTIAL AND COMMERCIAL SERVICES VIA COMPUTER NETWORK; ONLINE SERVICE FOR CONNECTING SOCIAL NETWORK USERS WITH RETAILERS FOR THE PURPOSE OF FACILITATING DISCOUNTED PURCHASES; PROMOTING THE GOODS AND SERVICES OF OTHERS BY PROVIDING A COMMUNITY-DRIVEN WEB SITE FEATURING USER-SUBMITTED CONTENT IN THE NATURE OF COUPONS, REBATES, PRICE-COMPARISON INFORMATION, PRODUCT REVIEWS, LINKS TO THE RETAIL WEB SITES OF OTHERS, AND DISCOUNT INFORMATION; PROMOTING THE GOODS AND SERVICES OF OTHERS BY PROVIDING A WEB SITE FEATURING COUPONS, REBATES, PRICE-COMPARISON INFORMATION, PRODUCT REVIEWS, LINKS TO THE RETAIL WEB SITES OF OTHERS, AND DISCOUNT INFORMATION; PROMOTING THE SALE OF GOODS AND SERVICES OF OTHERS THROUGH ELECTRONIC COUPONING, PROMOTIONS AND DISCOUNTS; PROVIDING A WEBSITE FOR USERS WITH SPECIFIC INFORMED RECOMMENDATIONS OF SPECIFIC CONSUMER PRODUCTS AND SERVICES VALIDATED BY THE USERS' INPUTTED PREFERENCES AND SOCIAL NETWORK; PROVIDING INFORMATION ABOUT THE GOODS AND SERVICES OF OTHERS VIA THE GLOBAL COMPUTER NETWORK (U.S. CLS. 100, 101 AND 102).

**CLASS 42—SCIENTIFIC AND COMPUTER SERVICES**

FOR COMPUTER SERVICES, NAMELY, CREATING AN ON-LINE COMMUNITY FOR REGISTERED USERS TO PARTICIPATE IN DISCUSSIONS, GET FEEDBACK FROM THEIR PEERS, FORM VIRTUAL COMMUNITIES, AND ENGAGE IN SOCIAL NETWORKING FEATURING PRODUCTS, SERVICES, SUPPORT, RESOURCES AND RATINGS; PROVIDING A WEB SITE FEATURING TECHNOLOGY THAT ENABLES USERS TO CONNECT WITH OTHER PEOPLE IN THEIR NEIGHBORHOOD OR CITY FOR ANY NUMBER OF USER-SPECIFIED REASONS, INCLUDING PROVIDING A SERVICE OR ORGANIZING AN EVENT; PROVIDING AN ONLINE NETWORK SERVICE THAT ENABLES USERS TO SHARE DATA IN THE FIELD OF PERSONAL, BUSINESS, AND FAMILY SUPPORT AND CONNECTIONS THROUGH RESOURCE NETWORKING; PROVIDING CUSTOMER-DEFINED GENERATED CONTENT AND CONTENT OF OTHERS AUTOMATICALLY SELECTED AND CUSTOMIZED BASED ON THE KNOWN OR ESTIMATED GEOGRAPHICAL LOCATION OF AN INTERNET, MOBILE TELEPHONE OR OTHER WIRED OR WIRELESS DIGITAL NETWORK BASED CUSTOMER (U.S. CLS. 100 AND 101).

**CLASS 45—PERSONAL AND LEGAL SERVICES**

FOR INTERNET-BASED SOCIAL NETWORKING SERVICES; ON-LINE SOCIAL NETWORKING SERVICES; PROVIDING ON-LINE COMPUTER DATABASES AND ON-LINE SEARCHABLE DATABASES IN THE FIELD OF SOCIAL NETWORKING (U.S. CLS. 100 AND 101).  
GENE MACIOL, EXAMINING ATTORNEY

SN 85-172,313. NBV, LLC, FENTON, MO. FILED 11-9-2010.

**EVERY BOTTLE COUNTS**

THE MARK CONSISTS OF STANDARD CHARACTERS WITHOUT CLAIM TO ANY PARTICULAR FONT, STYLE, SIZE, OR COLOR.

NO CLAIM IS MADE TO THE EXCLUSIVE RIGHT TO USE "BOTTLE", APART FROM THE MARK AS SHOWN.

**CLASS 21—HOUSEWARES AND GLASS**

FOR METAL BEVERAGE BOTTLES SOLD EMPTY (U.S. CLS. 2, 13, 23, 29, 30, 33, 40 AND 50).

**CLASS 25—CLOTHING**

FOR HATS, SHIRTS (U.S. CLS. 22 AND 39).  
KRISTINA MORRIS, EXAMINING ATTORNEY

SN 85-172,615. PAPER PLUS CONNECTION, INC., VERNON, CA. FILED 11-9-2010.

**BABY. LOVE**

THE MARK CONSISTS OF STANDARD CHARACTERS WITHOUT CLAIM TO ANY PARTICULAR FONT, STYLE, SIZE, OR COLOR.

**CLASS 16—PAPER GOODS AND PRINTED MATTER**

FOR BATHROOM TISSUE; NAPKIN PAPER; TOILET PAPER; TOILET TISSUE (U.S. CLS. 2, 5, 22, 23, 29, 37, 38 AND 50).

**CLASS 24—FABRICS**

FOR HAND TOWELS; KITCHEN TOWELS (U.S. CLS. 42 AND 50).  
BRIAN NEVILLE, EXAMINING ATTORNEY

SN 85-172,628. PAWSLEY, LLC, NEW YORK, NY. FILED 11-9-2010.

**Pawsley**

THE MARK CONSISTS OF STANDARD CHARACTERS WITHOUT CLAIM TO ANY PARTICULAR FONT, STYLE, SIZE, OR COLOR.

**CLASS 35—ADVERTISING AND BUSINESS**

FOR ON-LINE RETAIL STORE SERVICES FEATURING DOG-RELATED SERVICES AND ACCESSORIES; PROMOTING THE GOODS AND SERVICES OF OTHERS BY PROVIDING A WEBSITE FEATURING COUPONS, REBATES, PRICE-COMPARISON INFORMATION, PRODUCT REVIEWS, LINKS TO THE RETAIL WEBSITES OF OTHERS, AND DISCOUNT INFORMATION (U.S. CLS. 100, 101 AND 102).

FIRST USE 9-15-2010; IN COMMERCE 10-1-2010.

**CLASS 42—SCIENTIFIC AND COMPUTER SERVICES**

FOR COMPUTER SERVICES, NAMELY, CREATING AN ON-LINE COMMUNITY FOR REGISTERED USERS TO PARTICIPATE IN DISCUSSIONS, GET FEEDBACK FROM THEIR PEERS, FORM VIRTUAL COMMUNITIES, AND ENGAGE IN SOCIAL NETWORKING FEATURING SOCIAL MEDIA AND TOPICS ON DOGS AND DOG-RELATED SERVICES AND ACCESSORIES; PROVIDING A WEB SITE THAT GIVES COMPUTER USERS THE ABILITY TO UPLOAD, EXCHANGE AND SHARE PHOTOS, VIDEOS AND VIDEO LOGS (U.S. CLS. 100 AND 101).

FIRST USE 9-15-2010; IN COMMERCE 10-1-2010.  
MEGHAN REINHART, EXAMINING ATTORNEY

SN 85-173,615. CONOCOPHILLIPS COMPANY, HOUSTON, TX. FILED 11-10-2010.

# SERT

THE MARK CONSISTS OF STANDARD CHARACTERS WITHOUT CLAIM TO ANY PARTICULAR FONT, STYLE, SIZE, OR COLOR.

**CLASS 42—SCIENTIFIC AND COMPUTER SERVICES**

FOR TECHNOLOGY CONSULTATION IN THE FIELD OF HEAVY METAL SEPARATION PROCESSES (U.S. CLS. 100 AND 101).

**CLASS 45—PERSONAL AND LEGAL SERVICES**

FOR LICENSING OF TECHNOLOGY IN THE FIELD OF HEAVY METAL SEPARATION PROCESSES (U.S. CLS. 100 AND 101).

ZACHARY BELLO, EXAMINING ATTORNEY

SN 85-173,899. KB MEDIA GROUP, LLC, SAN FRANCISCO, CA. FILED 11-10-2010.

# KUSH BOYS

THE MARK CONSISTS OF STANDARD CHARACTERS WITHOUT CLAIM TO ANY PARTICULAR FONT, STYLE, SIZE, OR COLOR.

**CLASS 41—EDUCATION AND ENTERTAINMENT**

FOR ANIMATION PRODUCTION SERVICES; ENTERTAINMENT SERVICES, NAMELY, THE PROVISION OF CONTINUING PROGRAMS FEATURING ANIMATION DELIVERED BY INTERNET (U.S. CLS. 100, 101 AND 107).

FIRST USE 1-0-2006; IN COMMERCE 1-0-2006.

**CLASS 42—SCIENTIFIC AND COMPUTER SERVICES**

FOR CREATING AND DESIGNING WEB PAGES FOR OTHERS; GRAPHIC DESIGN SERVICES; GRAPHIC ILLUSTRATION SERVICES FOR OTHERS; MULTIDISCIPLINARY GRAPHIC DESIGN SERVICES; WEBSITE DESIGN AND DEVELOPMENT FOR OTHERS (U.S. CLS. 100 AND 101).

FIRST USE 1-0-2006; IN COMMERCE 1-0-2006.

ANGELA DUONG, EXAMINING ATTORNEY

SN 85-174,096. TRACY MILLS, VAN NUYS, CA. AND WARAIRE BOSWELL, LOS ANGELES, CA. FILED 11-10-2010.

# Venus & Mars

THE MARK CONSISTS OF STANDARD CHARACTERS WITHOUT CLAIM TO ANY PARTICULAR FONT, STYLE, SIZE, OR COLOR.

**CLASS 14—JEWELRY**

FOR BRACELETS; EARRINGS; JEWELRY; NECKLACES; RINGS; WOMEN'S JEWELRY (U.S. CLS. 2, 27, 28 AND 50).

**CLASS 25—CLOTHING**

FOR COATS FOR MEN AND WOMEN; HATS; HOODED SWEATSHIRTS; JACKETS; PANTS; SHIRTS; SKIRTS AND DRESSES; SWEATERS; SWEATSHIRTS; T-SHIRTS (U.S. CLS. 22 AND 39).

MARILYN IZZI, EXAMINING ATTORNEY

SN 85-174,209. MUL-T-LOCK LTD., YAVNE, ISRAEL, FILED 11-11-2010.

# PROQSIMITY

THE MARK CONSISTS OF STANDARD CHARACTERS WITHOUT CLAIM TO ANY PARTICULAR FONT, STYLE, SIZE, OR COLOR.

OWNER OF ISRAEL REG. NO. 212800, DATED 2-7-2010, EXPIRES 6-24-2015.

OWNER OF ISRAEL REG. NO. 212799, DATED 5-11-2010, EXPIRES 6-24-2015.

**CLASS 6—METAL GOODS**

FOR LOCKS, NAMELY METAL LOCKS, SECURITY LOCKS AND LOCK GOODS, ALSO INCLUDING LOCK CYLINDERS, MORTISE LOCKS, PADLOCKS, MULTI-POINT LOCKS, KEYS AND KEY BLANKS, LOCKS BOLTS, PADLOCK HASPS, LOCK CASES, SAFETY CHAINS, STRIKING PLATES, KEY RINGS, KING-PIN LOCKS, SHIPMENT CONTAINER LOCKS; SAFES, HINGES AND DOOR AND WINDOWS HANDLES; EMERGENCY AND PANIC DEVICES FOR DOORS AND WINDOWS; PARTS AND ACCESSORIES FOR ALL THE AFORESAID GOODS; ALL THE AFORESAID GOODS BEING OF METAL OR PREDOMINANTLY OF METAL (U.S. CLS. 2, 12, 13, 14, 23, 25 AND 50).

**CLASS 9—ELECTRICAL AND SCIENTIFIC APPARATUS**

FOR ELECTRIC, ELECTRONIC AND ELECTROMECHANICAL LOCKS AND LOCK GOODS, NAMELY, ELECTRONIC LOCK CYLINDERS, ELECTRIC STRIKING PLATES, DOOR MAGNETS, ELECTRONIC KEYS, KEY CARDS, ELECTRONIC OR MAGNETIC ACCESS CONTROL CARDS AND SMART CARDS, AND KEY CARD READERS; ELECTRONIC AND MAGNETIC ACCESS CONTROL CARD READERS AND SMART CARD READERS; COMPUTERS AND COMPUTER ATTACHMENTS FOR PROGRAMMING LOCKS, LOCK CYLINDERS, KEYS, KEY CARDS AND KEY CARD READERS, NAMELY, COMPUTER PROGRAMMING SYSTEMS AND COMPUTER PERIPHERALS NAMELY USB PROGRAMMING DEVICE, PROGRAMMING KEY, NETWORK PROGRAMMING DEVICE, RS232 PROGRAMMING DEVICE USED TO UPLOAD/DOWNLOAD INFORMATION PERTAINING AN ELECTRONIC ACCESS CONTROL SYSTEM INFORMATION; ELECTROMECHANICAL AND ELECTRO HYDRAULICAL DOOR OPENERS, DOOR CLOSERS AND DOOR OPERATORS; ELECTRIC AND ELECTRO MECHANICAL DOOR AND WINDOW HARDWARE; ELECTRONIC AND MAGNETIC SENSORS; APPARATUS AND INSTRUMENTS FOR SIGNALLING AND CHECKING, NAMELY, SENSORS FOR CHECKING AND/OR CONTROLLING PEOPLE'S MOVEMENT WITHIN, ENTRANCE TO AND EXIT FROM BUILDINGS AND THROUGH DOORS AND GATES AND/OR FOR USE WITH LOCKS; MAGNETIC AND ELECTRONIC IDENTITY CARDS; MAGNETIC ACCESS CONTROL CARDS AND TAGS; COMPUTER SOFTWARE, NAMELY, SOFTWARE FOR MANAGEMENT OF KEYING SYSTEMS (U.S. CLS. 21, 23, 26, 36 AND 38).

SUZANNE BLANE, EXAMINING ATTORNEY

SN 85-174,278. SICURA DESIGNS, INC., JERSEY CITY, NJ. FILED 11-11-2010.

**DOG HAUS**

THE MARK CONSISTS OF STANDARD CHARACTERS WITHOUT CLAIM TO ANY PARTICULAR FONT, STYLE, SIZE, OR COLOR.

NO CLAIM IS MADE TO THE EXCLUSIVE RIGHT TO USE "DOG", APART FROM THE MARK AS SHOWN.

**CLASS 18—LEATHER GOODS**

FOR PET CLOTHING (U.S. CLS. 1, 2, 3, 22 AND 41).

**CLASS 21—HOUSEWARES AND GLASS**

FOR GROOMING TOOLS FOR PETS, NAMELY, COMBS AND BRUSHES; PET FEEDING AND DRINKING BOWLS (U.S. CLS. 2, 13, 23, 29, 30, 33, 40 AND 50).

**CLASS 28—TOYS AND SPORTING GOODS**

FOR PET TOYS (U.S. CLS. 22, 23, 38 AND 50).  
ADA HAN, EXAMINING ATTORNEY

SN 85-174,356. KAPOW TECHNOLOGIES HOLDINGS, INC., PALO ALTO, CA. FILED 11-11-2010.

**KAPOW SOFTWARE**

THE MARK CONSISTS OF STANDARD CHARACTERS WITHOUT CLAIM TO ANY PARTICULAR FONT, STYLE, SIZE, OR COLOR.

OWNER OF U.S. REG. NOS. 3,807,693 AND 3,807,694.

NO CLAIM IS MADE TO THE EXCLUSIVE RIGHT TO USE "SOFTWARE", APART FROM THE MARK AS SHOWN.

**CLASS 9—ELECTRICAL AND SCIENTIFIC APPARATUS**

FOR COMPUTER SOFTWARE FOR USE IN ACCESSING, TRANSFORMING, SEARCHING, COMPILING, INDEXING, CONNECTING, COLLECTING, COMBINING, ORGANIZING AND MANIPULATING FROM MULTIPLE SOURCES DATA, MULTIMEDIA CONTENT, INFORMATION AND BUSINESS INTELLIGENCE ON THE INTERNET INTO USABLE FORM; COMPUTER SOFTWARE FOR CREATING INDEXES OF INFORMATION, WEB SITES, AND OTHER INFORMATION RESOURCES; COMPUTER SOFTWARE FOR ENHANCING THE CAPABILITIES OF WEB BROWSER SOFTWARE; CUSTOMIZABLE COMPUTER WEB BROWSER SOFTWARE FOR ACCESSING, CREATING, COLLECTING, STORING, REMOVING, TRANSFERRING, DISSEMINATING, ORGANIZING, AND SEARCHING TEXT, GRAPHICS OR OTHER DATA; CUSTOMIZABLE COMPUTER SOFTWARE FOR ACCESSING, CREATING, COLLECTING, STORING, REMOVING, TRANSFERRING, DISSEMINATING, ORGANIZING, AND SEARCHING DATA OVER A GLOBAL COMPUTER NETWORK AND OTHER NETWORKS; COMPUTER SOFTWARE FOR UPDATING AND INTEGRATING DATA, USER SPECIFICATIONS AND NETWORK SPECIFICATIONS OVER WIRELESS AND WIRELINE NETWORKS; COMPUTER SOFTWARE FOR INTEGRATING WEB TECHNOLOGIES; COMPUTER SOFTWARE FOR DEVELOPING AND PROGRAMMING INTERACTIVE MOBILE AND EMBEDDED APPLICATIONS; AND INSTRUCTIONAL MANUALS, SOLD AS A UNIT (U.S. CLS. 21, 23, 26, 36 AND 38).

**CLASS 38—COMMUNICATION**

FOR TELECOMMUNICATION SERVICES, NAMELY, RENTAL OF ACCESS TIME TO GLOBAL COMPUTER NETWORKS, AND PROVIDING ONLINE ACCESS TO DATABASES; PROVIDING MULTIPLE USER ACCESS TO PROPRIETARY COLLECTIONS OF INFORMATION BY MEANS OF GLOBAL COMPUTER INFORMATION NETWORKS (U.S. CLS. 100, 101 AND 104).

**CLASS 42—SCIENTIFIC AND COMPUTER SERVICES**

FOR COMPUTER SOFTWARE CONSULTATION SERVICES; COMPUTER CONSULTANCY IN THE FIELDS OF DATABASES, WEB BROWSERS, WEB SITES AND WEB HOSTING SERVICES AND PROGRAMMING COMPUTER SERVICES, NAMELY, PROVIDING SOFTWARE INTERFACES AVAILABLE OVER A COMPUTER NETWORK IN ORDER FOR USERS TO CREATE A PERSONALIZED ON-LINE INFORMATION AND DATA RETRIEVAL AND EXTRACTION SERVICE; COMPUTER SERVICE, NAMELY, ACTING AS AN APPLICATION SERVICE PROVIDER IN THE FIELD OF KNOWLEDGE MANAGEMENT TO HOST COMPUTER APPLICATION SOFTWARE FOR THE COLLECTION, EDITING, ORGANIZING, MODIFYING, BOOK MARKING, TRANSMISSION, STORAGE AND SHARING OF DATA AND INFORMATION; DATA MINING, NAMELY, EXTRACTION AND RETRIEVAL OF INFORMATION BY MEANS OF GLOBAL COMPUTER NETWORKS; CREATING INDEXES OF INFORMATION, WEB SITES AND OTHER INFORMATION SOURCES IN CONNECTION WITH GLOBAL COMPUTER NETWORKS; PROVIDING INFORMATION AT THE SPECIFIC REQUEST OF END-USERS BY MEANS OF GLOBAL COMPUTER INFORMATION NETWORKS; PROVIDING ONLINE NON-DOWNLOADABLE COMPUTER SOFTWARE FOR USE IN SEARCHING, COMPILING, INDEXING, CONNECTING, COLLECTING, COMBINING AND ORGANIZING FROM MULTIPLE SOURCES DATA, MULTIMEDIA CONTENT, INFORMATION AND BUSINESS INTELLIGENCE ON THE INTERNET AND FOR USE IN CREATING INDEXES OF INFORMATION, WEB SITES AND OTHER INFORMATION RESOURCES (U.S. CLS. 100 AND 101).

TRACY CROSS, EXAMINING ATTORNEY

**CLASS 9—ELECTRICAL AND SCIENTIFIC APPARATUS**

FOR COMPUTER SOFTWARE FOR USE IN ACCESSING, TRANSFORMING, SEARCHING, COMPILING, INDEXING, CONNECTING, COLLECTING, COMBINING, ORGANIZING AND MANIPULATING FROM MULTIPLE SOURCES DATA, MULTIMEDIA CONTENT, INFORMATION AND BUSINESS INTELLIGENCE ON THE INTERNET INTO USABLE FORM; COMPUTER SOFTWARE FOR CREATING INDEXES OF INFORMATION, WEB SITES, AND OTHER INFORMATION RESOURCES; COMPUTER SOFTWARE FOR ENHANCING THE CAPABILITIES OF WEB BROWSER SOFTWARE; CUSTOMIZABLE COMPUTER WEB BROWSER SOFTWARE FOR ACCESSING, CREATING, COLLECTING, STORING, REMOVING, TRANSFERRING, DISSEMINATING, ORGANIZING, AND SEARCHING TEXT, GRAPHICS OR OTHER DATA; CUSTOMIZABLE COMPUTER SOFTWARE FOR ACCESSING, CREATING, COLLECTING, STORING, REMOVING, TRANSFERRING, DISSEMINATING, ORGANIZING, AND SEARCHING DATA OVER A GLOBAL COMPUTER NETWORK AND OTHER NETWORKS; COMPUTER SOFTWARE FOR UPDATING AND INTEGRATING DATA, USER SPECIFICATIONS AND NETWORK SPECIFICATIONS OVER WIRELESS AND WIRELINE NETWORKS; COMPUTER SOFTWARE FOR INTEGRATING WEB TECHNOLOGIES; COMPUTER SOFTWARE FOR DEVELOPING AND PROGRAMMING INTERACTIVE MOBILE AND EMBEDDED APPLICATIONS; AND INSTRUCTIONAL MANUALS, SOLD AS A UNIT (U.S. CLS. 21, 23, 26, 36 AND 38).

**CLASS 38—COMMUNICATION**

FOR TELECOMMUNICATION SERVICES, NAMELY, RENTAL OF ACCESS TIME TO GLOBAL COMPUTER NETWORKS, AND PROVIDING ONLINE ACCESS TO DATABASES; PROVIDING MULTIPLE USER ACCESS TO PROPRIETARY COLLECTIONS OF INFORMATION BY MEANS OF GLOBAL COMPUTER INFORMATION NETWORKS (U.S. CLS. 100, 101 AND 104).

**CLASS 42—SCIENTIFIC AND COMPUTER SERVICES**

FOR COMPUTER SOFTWARE CONSULTATION SERVICES; COMPUTER CONSULTANCY IN THE FIELDS OF DATABASES, WEB BROWSERS, WEB SITES AND WEB HOSTING SERVICES AND PROGRAMMING COMPUTER SERVICES, NAMELY, PROVIDING SOFTWARE INTERFACES AVAILABLE OVER A COMPUTER NETWORK IN ORDER FOR USERS TO CREATE A PERSONALIZED ON-LINE INFORMATION AND DATA RETRIEVAL AND EXTRACTION SERVICE; COMPUTER SERVICE, NAMELY, ACTING AS AN APPLICATION SERVICE PROVIDER IN THE FIELD OF KNOWLEDGE MANAGEMENT TO HOST COMPUTER APPLICATION SOFTWARE FOR THE COLLECTION, EDITING, ORGANIZING, MODIFYING, BOOK MARKING, TRANSMISSION, STORAGE AND SHARING OF DATA AND INFORMATION; DATA MINING, NAMELY, EXTRACTION AND RETRIEVAL OF INFORMATION BY MEANS OF GLOBAL COMPUTER NETWORKS; CREATING INDEXES OF INFORMATION, WEB SITES AND OTHER INFORMATION SOURCES IN CONNECTION WITH GLOBAL COMPUTER NETWORKS; PROVIDING INFORMATION AT THE SPECIFIC REQUEST OF END-USERS BY MEANS OF GLOBAL COMPUTER INFORMATION NETWORKS; PROVIDING ONLINE NON-DOWNLOADABLE COMPUTER SOFTWARE FOR USE IN SEARCHING, COMPILING, INDEXING, CONNECTING, COLLECTING, COMBINING AND ORGANIZING FROM MULTIPLE SOURCES DATA, MULTIMEDIA CONTENT, INFORMATION AND BUSINESS INTELLIGENCE ON THE INTERNET AND FOR USE IN CREATING INDEXES OF INFORMATION, WEB SITES AND OTHER INFORMATION RESOURCES (U.S. CLS. 100 AND 101).

TRACY CROSS, EXAMINING ATTORNEY

SN 85-174,363. KAPOW TECHNOLOGIES HOLDINGS, INC., PALO ALTO, CA. FILED 11-11-2010.



OWNER OF U.S. REG. NOS. 3,807,693 AND 3,807,694.  
NO CLAIM IS MADE TO THE EXCLUSIVE RIGHT TO USE "SOFTWARE", APART FROM THE MARK AS SHOWN.  
THE MARK CONSISTS OF THE WORDS "KAPOW SOFTWARE" WITH AN ARBITRARY DESIGN FORMING THE LETTER "O" IN THE WORD "KAPOW".

SN 85-174,596. ASPEN DENTAL MANAGEMENT, INC., EAST SYRACUSE, NY. FILED 11-11-2010.

**AspenDental**  
It's time to smile.

OWNER OF U.S. REG. NOS. 3,295,706, 3,805,810 AND OTHERS.

THE MARK CONSISTS OF THE WORDS "ASPENDENTAL" WITH A MOUNTAIN PEAK FORMING THE TOP OF THE "A" IN "ASPEN" POSITIONED ABOVE THE TAG LINE "IT'S TIME TO SMILE."

**CLASS 40—MATERIAL TREATMENT**

FOR CUSTOM MANUFACTURE OF DENTAL PROSTHETICS; DENTAL LABORATORIES (U.S. CLS. 100, 103 AND 106).

**CLASS 44—MEDICAL, BEAUTY AND AGRICULTURAL SERVICES**

FOR COSMETIC DENTISTRY; DENTISTRY (U.S. CLS. 100 AND 101).  
COLLEEN KEARNEY, EXAMINING ATTORNEY

**CLASS 9—ELECTRICAL AND SCIENTIFIC APPARATUS**

FOR DIGITAL MEDIA, NAMELY, PRE-RECORDED VIDEO CASSETTES, DIGITAL VIDEO DISCS, DIGITAL VERSATILE DISCS, DOWNLOADABLE AUDIO AND VIDEO RECORDINGS, DVDS, AND HIGH DEFINITION DIGITAL DISCS FEATURING MUSICAL PERFORMANCES, SERMONS, LECTURES AND INTERVIEWS IN THE FIELDS OF RELIGION, HEALTH, EDUCATION AND FAMILY LIFE; DOWNLOADABLE ELECTRONIC NEWSLETTERS IN THE FIELD OF RELIGION, HEALTH, EDUCATION AND FAMILY LIFE; PRERECORDED AUDIO TAPES FEATURING MUSICAL PERFORMANCES, SERMONS, LECTURES AND INTERVIEWS IN THE FIELDS OF RELIGION, HEALTH, EDUCATION AND FAMILY LIFE (U.S. CLS. 21, 23, 26, 36 AND 38).

FIRST USE 10-0-2010; IN COMMERCE 10-0-2010.

**CLASS 16—PAPER GOODS AND PRINTED MATTER**

FOR BOOKS IN THE FIELD OF RELIGION, HEALTH, EDUCATION AND FAMILY LIFE; MAGAZINES IN THE FIELD OF RELIGION, HEALTH, EDUCATION AND FAMILY LIFE; NEWSLETTERS IN THE FIELD OF RELIGION, HEALTH, EDUCATION AND FAMILY LIFE; PAMPHLETS IN THE FIELD OF RELIGION, HEALTH, EDUCATION AND FAMILY LIFE (U.S. CLS. 2, 5, 22, 23, 29, 37, 38 AND 50).

FIRST USE 10-0-2010; IN COMMERCE 10-0-2010.

**CLASS 38—COMMUNICATION**

FOR BROADCASTING OF RADIO AND TELEVISION PROGRAMS; CABLE TELEVISION BROADCASTING; INTERNET BROADCASTING SERVICES; INTERNET RADIO BROADCASTING SERVICES; SATELLITE TRANSMISSION SERVICES, TELEVISION AND RADIO BROADCASTING SERVICES (U.S. CLS. 100, 101 AND 104).

FIRST USE 10-0-2010; IN COMMERCE 10-0-2010.  
DOMINICK J. SALEMI, EXAMINING ATTORNEY

SN 85-174,956. THREE ANGELS BROADCASTING NETWORK, INC., WEST FRANKFORT, IL. FILED 11-11-2010.



THE MARK CONSISTS OF A DRAWING OF AN INCOMPLETE CIRCLE FORMED BY FOUR SOLID ARCHES: THREE STACKED FORMING THE LEFT SIDE OF THE CIRCLE AND ONE FORMING THE RIGHT SIDE. THE COLOR WHITE REPRESENTS BACKGROUND AND IS NOT PART OF THE MARK.

SN 85-175,526. SAMMY CHAN, SACRAMENTO, CA. FILED 11-12-2010.

**ROSCO**

THE MARK CONSISTS OF STANDARD CHARACTERS WITHOUT CLAIM TO ANY PARTICULAR FONT, STYLE, SIZE, OR COLOR.

**CLASS 4—LUBRICANTS AND FUELS**

FOR MOTOR OIL (U.S. CLS. 1, 6 AND 15).

**CLASS 19—NON-METALLIC BUILDING MATERIALS**

FOR ARTIFICIAL STONE (U.S. CLS. 1, 12, 33 AND 50).  
SUNG IN, EXAMINING ATTORNEY

SN 85-175,617. JAMES P. OWEN, AUSTIN, TX. FILED 11-12-2010.

SN 85-176,091. SKYDOX LTD, WITNEY, UNITED KINGDOM, FILED 11-13-2010.

## COWBOY ETHICS

THE MARK CONSISTS OF STANDARD CHARACTERS WITHOUT CLAIM TO ANY PARTICULAR FONT, STYLE, SIZE, OR COLOR.

NO CLAIM IS MADE TO THE EXCLUSIVE RIGHT TO USE "ETHICS", APART FROM THE MARK AS SHOWN.

### CLASS 16—PAPER GOODS AND PRINTED MATTER

FOR POSTERS (U.S. CLS. 2, 5, 22, 23, 29, 37, 38 AND 50).

### CLASS 41—EDUCATION AND ENTERTAINMENT

FOR EDUCATIONAL AND ENTERTAINMENT SERVICES, NAMELY, PROVIDING MOTIVATIONAL SPEAKING SERVICES AND CLASSES, SEMINARS, WORKSHOPS AND PROGRAMS IN THE FIELDS OF LEADERSHIP, MOTIVATION, INSPIRATION, PERSEVERANCE, VALUES, AND PERSONAL GROWTH AND DEVELOPMENT (U.S. CLS. 100, 101 AND 107).

GISELLE AGOSTO, EXAMINING ATTORNEY

## SKYDOX

THE MARK CONSISTS OF STANDARD CHARACTERS WITHOUT CLAIM TO ANY PARTICULAR FONT, STYLE, SIZE, OR COLOR.

### CLASS 9—ELECTRICAL AND SCIENTIFIC APPARATUS

FOR COMPUTER SOFTWARE, NAMELY, SOFTWARE THAT ENABLES CO-AUTHORING, VERSION CONTROL, CENTRAL STORAGE, SYNCHRONIZATION, SECURE SHARING, MONITORING AND INTUITIVE RETRIEVAL OF DATA FILES RELATING TO THE CREATION OF IDEAS AND DOCUMENTS USING POPULAR BUSINESS AND PERSONAL SOFTWARE APPLICATIONS (U.S. CLS. 21, 23, 26, 36 AND 38).

FIRST USE 8-8-2010; IN COMMERCE 9-13-2010.

### CLASS 42—SCIENTIFIC AND COMPUTER SERVICES

FOR PROVIDING ON-LINE NON-DOWNLOADABLE SOFTWARE THAT ENABLES CO-AUTHORING, VERSION CONTROL, CENTRAL STORAGE, SYNCHRONIZATION, SECURE SHARING, MONITORING AND INTUITIVE RETRIEVAL OF DATA FILES RELATING TO THE CREATION OF IDEAS AND DOCUMENTS USING POPULAR BUSINESS AND PERSONAL SOFTWARE APPLICATIONS (U.S. CLS. 100 AND 101).

FIRST USE 8-8-2010; IN COMMERCE 9-13-2010.

EDWARD FENNESSY, EXAMINING ATTORNEY

SN 85-175,737. TECTRANS INC., LOS ANGELES, CA. FILED 11-12-2010.

SN 85-176,134. CULOTTA LAW FIRM, PLLC, SEABROOK, TX. FILED 11-13-2010.

## TECTRANS

THE MARK CONSISTS OF THE WORDING "TECTRANS" WITH A TRIANGULAR ROADWAY DESIGN INCORPORATED INTO THE LETTER "A".

### CLASS 39—TRANSPORTATION AND STORAGE

FOR TAXI, LIMOUSINE, BUS, SHUTTLE AND CAR TRANSPORT SERVICES; TRANSPORTATION CONSULTATION (U.S. CLS. 100 AND 105).

FIRST USE 12-1-2004; IN COMMERCE 6-21-2006.

### CLASS 42—SCIENTIFIC AND COMPUTER SERVICES

FOR MASS TRANSIT IT CONSULTING SERVICES (U.S. CLS. 100 AND 101).

FIRST USE 12-1-2004; IN COMMERCE 6-21-2006.  
MICHAEL ENGEL, EXAMINING ATTORNEY



THE COLOR(S) YELLOW, RED, BLACK AND WHITE IS/ARE CLAIMED AS A FEATURE OF THE MARK.

THE MARK CONSISTS OF NON-GENDER SPECIFIC DEPICTION OF A HUMAN BODY COLORED WHITE WITH A YELLOW ELECTRIC LIGHT BULB FOR A HEAD AND A RED EXCLAMATION POINT INSIDE THE YELLOW LIGHT BULB. BOTH PARTS OF THE EXCLAMATION POINT ARE RED. RAYS EMANATING FROM THE ELECTRIC LIGHT BULB HEAD ARE YELLOW. THE ELEMENTS OF THE BASE OF THE ELECTRIC LIGHT BULB EXTENDING OVER THE WHITE HUMAN BODY ARE BLACK. THE SKYSCRAPER IS BLACK. THE WINDOWS IN THE SKYSCRAPER ARE WHITE.



**CLASS 35—ADVERTISING AND BUSINESS**

FOR BUSINESS SERVICES, NAMELY, STRUCTURING, OPTIMIZING AND CHANGE MANAGEMENT CONSULTING RELATED TO CORPORATE IN-HOUSE INTELLECTUAL PROPERTY DEPARTMENTS AND INTELLECTUAL PROPERTY ASSET MANAGEMENT PROGRAMS; CONSULTING REGARDING INTELLECTUAL PROPERTY BUSINESS RISK MITIGATION PROCESSES; CONSULTING SERVICES IN THE FIELD OF MANAGING INTELLECTUAL PROPERTIES (U.S. CLS. 100, 101 AND 102).

**CLASS 36—INSURANCE AND FINANCIAL**

FOR ADVISING OTHERS CONCERNING INVESTMENTS IN INTELLECTUAL PROPERTY ASSETS AND INTANGIBLE BUSINESS ASSETS, BOTH DIRECTLY AND INDIRECTLY THROUGH OTHER ENTITIES; CONSULTING ON THE SUBJECT OF INTELLECTUAL PROPERTY VALUATION; INTELLECTUAL PROPERTY VALUATION SERVICES (U.S. CLS. 100, 101 AND 102).

**CLASS 41—EDUCATION AND ENTERTAINMENT**

FOR EDUCATIONAL SERVICES, NAMELY, CONDUCTING CLASSES, SEMINARS, CONFERENCES, WORKSHOPS BOTH IN-PERSON, ELECTRONICALLY DISTRIBUTED, LIVE OR RECORDED IN MACHINE-READABLE FORMAT IN THE FIELD OF INTELLECTUAL PROPERTY AND DISTRIBUTION OF EDUCATIONAL MATERIALS IN CONNECTION THEREWITH; EDUCATIONAL SERVICES, NAMELY, PROVIDING EDUCATIONAL SPEAKERS IN THE FIELD OF INTELLECTUAL PROPERTY (U.S. CLS. 100, 101 AND 107).

**CLASS 45—PERSONAL AND LEGAL SERVICES**

FOR CONSULTING IN THE FIELD OF INTELLECTUAL PROPERTY LICENSING; INTELLECTUAL PROPERTY CONSULTATION; INTELLECTUAL PROPERTY WATCH SERVICES; LEGAL SERVICES; LEGAL SERVICES, NAMELY, INTELLECTUAL PROPERTY CONSULTING SERVICES IN THE FIELD OF INVENTION, IDENTIFICATION, STRATEGY, ANALYTICS, AND INVENTION; LEGAL SERVICES, NAMELY, PREPARATION OF APPLICATIONS FOR TRADEMARK REGISTRATION; LICENSING OF INTELLECTUAL PROPERTY; PATENT AGENT SERVICES; PATENT LICENSING; PROVIDING INFORMATION IN THE FIELD OF INTELLECTUAL PROPERTY LEGAL SERVICES ; PROVIDING INFORMATION IN THE FIELD OF INTELLECTUAL PROPERTY ; PROVIDING ON-LINE INFORMATION IN THE FIELD OF INTELLECTUAL PROPERTY; PROVIDING ON-LINE INFORMATION IN THE FIELD OF INTELLECTUAL PROPERTY LEGAL SERVICES (U.S. CLS. 100 AND 101).

ROSELLE HERRERA, EXAMINING ATTORNEY

**CLASS 35—ADVERTISING AND BUSINESS**

FOR BUSINESS SERVICES, NAMELY, STRUCTURING, OPTIMIZING AND CHANGE MANAGEMENT CONSULTING RELATED TO CORPORATE IN-HOUSE INTELLECTUAL PROPERTY DEPARTMENTS AND INTELLECTUAL PROPERTY ASSET MANAGEMENT PROGRAMS; CONSULTING REGARDING INTELLECTUAL PROPERTY BUSINESS RISK MITIGATION PROCESSES; CONSULTING SERVICES IN THE FIELD OF MANAGING INTELLECTUAL PROPERTIES (U.S. CLS. 100, 101 AND 102).

**CLASS 36—INSURANCE AND FINANCIAL**

FOR ADVISING OTHERS CONCERNING INVESTMENTS IN INTELLECTUAL PROPERTY ASSETS AND INTANGIBLE BUSINESS ASSETS, BOTH DIRECTLY AND INDIRECTLY THROUGH OTHER ENTITIES; CONSULTING ON THE SUBJECT OF INTELLECTUAL PROPERTY VALUATION; INTELLECTUAL PROPERTY VALUATION SERVICES (U.S. CLS. 100, 101 AND 102).

**CLASS 41—EDUCATION AND ENTERTAINMENT**

FOR EDUCATIONAL SERVICES, NAMELY, CONDUCTING CLASSES, SEMINARS, CONFERENCES, WORKSHOPS BOTH IN-PERSON, ELECTRONICALLY DISTRIBUTED, LIVE OR RECORDED IN MACHINE-READABLE FORMAT IN THE FIELD OF INTELLECTUAL PROPERTY AND DISTRIBUTION OF EDUCATIONAL MATERIALS IN CONNECTION THEREWITH; EDUCATIONAL SERVICES, NAMELY, PROVIDING EDUCATIONAL SPEAKERS IN THE FIELD OF INTELLECTUAL PROPERTY (U.S. CLS. 100, 101 AND 107).

**CLASS 45—PERSONAL AND LEGAL SERVICES**

FOR CONSULTING IN THE FIELD OF INTELLECTUAL PROPERTY LICENSING; INTELLECTUAL PROPERTY CONSULTATION; INTELLECTUAL PROPERTY WATCH SERVICES; LEGAL SERVICES; LEGAL SERVICES, NAMELY, INTELLECTUAL PROPERTY CONSULTING SERVICES IN THE FIELD OF INVENTION, IDENTIFICATION, STRATEGY, ANALYTICS, AND INVENTION; LEGAL SERVICES, NAMELY, PREPARATION OF APPLICATIONS FOR TRADEMARK REGISTRATION; LICENSING OF INTELLECTUAL PROPERTY; PATENT AGENT SERVICES; PATENT LICENSING; PROVIDING INFORMATION IN THE FIELD OF INTELLECTUAL PROPERTY LEGAL SERVICES ; PROVIDING INFORMATION IN THE FIELD OF INTELLECTUAL PROPERTY ; PROVIDING ON-LINE INFORMATION IN THE FIELD OF INTELLECTUAL PROPERTY; PROVIDING ON-LINE INFORMATION IN THE FIELD OF INTELLECTUAL PROPERTY LEGAL SERVICES (U.S. CLS. 100 AND 101).

ROSELLE HERRERA, EXAMINING ATTORNEY

SN 85-176,143. CULOTTA LAW FIRM, PLLC, SEABROOK, TX. FILED 11-13-2010.

SN 85-176,429. COINMACH CORPORATION, PLAINVIEW, NY. FILED 11-15-2010.

What are your ideas  
building for you?

COINMACH

THE MARK CONSISTS OF STANDARD CHARACTERS WITHOUT CLAIM TO ANY PARTICULAR FONT, STYLE, SIZE, OR COLOR.

THE MARK CONSISTS OF STANDARD CHARACTERS WITHOUT CLAIM TO ANY PARTICULAR FONT, STYLE, SIZE, OR COLOR.

**CLASS 7—MACHINERY**

FOR LAUNDRY WASHING AND DRYING MACHINES (U.S. CLS. 13, 19, 21, 23, 31, 34 AND 35).  
FIRST USE 0-0-1948; IN COMMERCE 0-0-1948.

**CLASS 37—CONSTRUCTION AND REPAIR**

FOR PROVIDING WASHING AND DRYING LAUNDRY FACILITIES; RENTAL AND MAINTENANCE OF COIN AND NON-COIN OPERATED LAUNDRY EQUIPMENT TO MULTI-FAMILY PROPERTIES, COLLEGE DORMITORIES, MILITARY EXCHANGES, PRISONS AND SELF-SERVICE AND/OR STAFFED LAUNDRIES (U.S. CLS. 100, 103 AND 106).

FIRST USE 3-6-1948; IN COMMERCE 3-6-1948.  
CARYN GLASSER, EXAMINING ATTORNEY

SN 85-176,450. TRACY TRIVAS, SANTA MONICA, CA. FILED 11-15-2010.

# Wish Stealers

THE MARK CONSISTS OF STANDARD CHARACTERS WITHOUT CLAIM TO ANY PARTICULAR FONT, STYLE, SIZE, OR COLOR.

**CLASS 16—PAPER GOODS AND PRINTED MATTER**

FOR A SERIES OF CHILDREN'S BOOKS (U.S. CLS. 2, 5, 22, 23, 29, 37, 38 AND 50).

**CLASS 41—EDUCATION AND ENTERTAINMENT**

FOR ENTERTAINMENT SERVICES, NAMELY, PRODUCTION AND DISTRIBUTION OF MOTION PICTURES, ANIMATED AND DRAMATIC TELEVISION SERIES FOR CHILDREN RENDERED THROUGH THE MEDIA OF SATELLITE, RADIO, TELEPHONE AND BROADBAND SYSTEMS, AND VIA THE INTERNET, AND PORTABLE AND WIRELESS COMMUNICATION DEVICES; AND PROVIDING INFORMATION IN THE FIELD OF ENTERTAINMENT RENDERED VIA THE INTERNET, AND PORTABLE AND WIRELESS COMMUNICATION DEVICES (U.S. CLS. 100, 101 AND 107).

MARK PILARO, EXAMINING ATTORNEY

SN 85-176,485. RUSTY PITTMAN, CAMARILLO, CA. FILED 11-15-2010.

# FLOCK&BUY

THE MARK CONSISTS OF STANDARD CHARACTERS WITHOUT CLAIM TO ANY PARTICULAR FONT, STYLE, SIZE, OR COLOR.

**CLASS 35—ADVERTISING AND BUSINESS**

FOR DISTRIBUTORSHIP SERVICES IN THE FIELD OF CONSTRUCTION MATERIALS (U.S. CLS. 100, 101 AND 102).

**CLASS 37—CONSTRUCTION AND REPAIR**

FOR CONSULTING IN THE FIELD OF BUILDING CONSTRUCTION; RESIDENTIAL AND BUILDING CONSTRUCTION CONSULTING (U.S. CLS. 100, 103 AND 106).

CARYN GLASSER, EXAMINING ATTORNEY

SN 85-176,525. TOTAL SECURITY SERVICES INTERNATIONAL, INC., AKA TSSI, ROCKVILLE, MD. FILED 11-15-2010.

# INTELISHARE

THE MARK CONSISTS OF STANDARD CHARACTERS WITHOUT CLAIM TO ANY PARTICULAR FONT, STYLE, SIZE, OR COLOR.

**CLASS 42—SCIENTIFIC AND COMPUTER SERVICES**

FOR DESIGN AND DEVELOPMENT OF ELECTRONIC DATA SECURITY SYSTEMS; DESIGN AND DEVELOPMENT OF HOME SECURITY SYSTEMS; DEVELOPING AND IMPLEMENTING CUSTOMIZED PLANS FOR IMPROVING SECURITY AND PREVENTING CRIMINAL ACTIVITY FOR BUSINESSES AND GOVERNMENTAL AGENCIES; PROVIDING A WEB SITE THAT GIVES COMPUTER USERS THE ABILITY TO UPLOAD AND SHARE VIDEO-BASED SCIENTIFIC PROTOCOLS AND OTHER SCIENTIFIC-BASED VIDEOS; RESEARCH IN THE FIELD OF INTELLIGENCE AND SECURITY TECHNOLOGY; TESTING OF SECURITY SYSTEMS (U.S. CLS. 100 AND 101).

**CLASS 45—PERSONAL AND LEGAL SERVICES**

FOR CONSULTANCY SERVICES IN THE FIELD OF HOME SECURITY; CONSULTATION SERVICES CONCERNING HOMELAND SAFETY AND SECURITY ISSUES; CONSULTING SERVICES IN THE FIELD OF HOMELAND SECURITY; CONSULTING SERVICES IN THE FIELD OF NATIONAL SECURITY; PROVIDING INFORMATION CONCERNING HOMELAND SAFETY AND SECURITY ISSUES; PROVIDING INTELLIGENCE AND INFORMATION TO LOCAL, STATE, AND FEDERAL LAW ENFORCEMENT AGENCIES RELATING TO ORGANIZED CRIME NETWORKS THAT OPERATE ACROSS JURISDICTIONAL LINES; PROVIDING NEWS CONCERNING HOMELAND SAFETY AND SECURITY ISSUES; SAFETY CONSULTING SERVICES IN THE FIELDS OF HAZARD ASSESSMENTS AND ABATEMENT PROCEDURES; SECURITY CONSULTANCY; SECURITY SERVICES, NAMELY, PROVIDING SECURITY ASSESSMENTS FOR BUSINESSES AND GOVERNMENTAL AGENCIES; SECURITY SERVICES, NAMELY, THREAT SIMULATION VULNERABILITY ANALYSIS AND MITIGATION AND EMERGENCY AND CRISIS RESPONSE (U.S. CLS. 100 AND 101).

LAKEISHA LEWIS, EXAMINING ATTORNEY

SN 85-176,626. OSTEO TECH, INC., EATONTOWN, NJ. FILED 11-15-2010.

SN 85-176,816. INTELLIGENT SYSTEMS (FREEZONE ESTABLISHMENT), SHARJAH, UNITED ARAB EMIR., FILED 11-15-2010.

# GCS

THE MARK CONSISTS OF STANDARD CHARACTERS WITHOUT CLAIM TO ANY PARTICULAR FONT, STYLE, SIZE, OR COLOR.

## CLASS 5—PHARMACEUTICALS

FOR BIOLOGICAL IMPLANTS, NAMELY, BIO-RESORBABLE IMPLANTS COMPRISING MINERALIZED AND DEMINERALIZED BONE TISSUE; ALLOGRAFT MATERIAL, NAMELY, HUMAN TISSUE AND BONE FOR SURGICAL IMPLANTS (U.S. CLS. 6, 18, 44, 46, 51 AND 52).

## CLASS 10—MEDICAL APPARATUS

FOR BIO-RESORBABLE DEVICE FOR DELIVERY OF BONE IMPLANTS FOR USE IN SURGICAL PROCEDURES (U.S. CLS. 26, 39 AND 44).

WILLIAM BRECKENFELD, EXAMINING ATTORNEY

---

SN 85-176,691. HYPERFOCUS RACING, INC., SANTA BARBARA, CA. FILED 11-15-2010.

# MOTOBUGGY

THE MARK CONSISTS OF STANDARD CHARACTERS WITHOUT CLAIM TO ANY PARTICULAR FONT, STYLE, SIZE, OR COLOR.

## CLASS 12—VEHICLES

FOR AUTOMOBILE STRUCTURAL PARTS FOR RACING PURPOSES, NAMELY, FUEL STORAGE CELLS; AUTOMOBILE STRUCTURAL PARTS FOR RACING PURPOSES, NAMELY, FUEL STORAGE SYSTEMS AND COMPONENT PARTS; CARS; CLUTCH MECHANISMS FOR MOTOR CARS; ELECTRIC CARS; ELECTRIC MOTORS FOR MOTOR CARS; RACING CARS; RACING MOTOR CARS (U.S. CLS. 19, 21, 23, 31, 35 AND 44).

## CLASS 41—EDUCATION AND ENTERTAINMENT

FOR ENTERTAINMENT IN THE NATURE OF AUTOMOBILE RACES; ENTERTAINMENT SERVICES IN THE NATURE OF AUTOMOBILE RACING AND EXHIBITIONS (U.S. CLS. 100, 101 AND 107).

CHRISTINA SOBRAL, EXAMINING ATTORNEY

# Rexton

THE MARK CONSISTS OF STANDARD CHARACTERS WITHOUT CLAIM TO ANY PARTICULAR FONT, STYLE, SIZE, OR COLOR.

THE WORDING "REXTON" HAS NO MEANING IN A FOREIGN LANGUAGE.

## CLASS 9—ELECTRICAL AND SCIENTIFIC APPARATUS

FOR ELECTRICAL SWITCHES; ELECTRICAL TRANSFORMERS (U.S. CLS. 21, 23, 26, 36 AND 38).

## CLASS 11—ENVIRONMENTAL CONTROL APPARATUS

FOR AIR CONDITIONERS; ELECTRIC FANS; PORTABLE ELECTRIC FANS (U.S. CLS. 13, 21, 23, 31 AND 34).

DEZMONA MIZELLE, EXAMINING ATTORNEY

---

SN 85-176,931. ANGELLIST, WOODSIDE, CA. FILED 11-15-2010.

# Angellist

THE MARK CONSISTS OF STANDARD CHARACTERS WITHOUT CLAIM TO ANY PARTICULAR FONT, STYLE, SIZE, OR COLOR.

## CLASS 35—ADVERTISING AND BUSINESS

FOR BUSINESS DEVELOPMENT SERVICES, NAMELY, PROVIDING START-UP SUPPORT FOR BUSINESSES OF OTHERS (U.S. CLS. 100, 101 AND 102).

FIRST USE 7-6-2010; IN COMMERCE 7-6-2010.

## CLASS 36—INSURANCE AND FINANCIAL

FOR INFORMATION, ADVISORY, CONSULTANCY AND RESEARCH SERVICES RELATING TO FINANCE AND INVESTMENTS; INVESTMENT OF FUNDS FOR OTHERS; VENTURE CAPITAL FUNDING SERVICES TO EMERGING AND START-UP COMPANIES (U.S. CLS. 100, 101 AND 102).

FIRST USE 7-6-2010; IN COMMERCE 7-6-2010.

KATHERINE STOIDES, EXAMINING ATTORNEY

SN 85-176,991. 621SHOP LLC, UPPER MARLBORO, MD.  
FILED 11-15-2010.

SN 85-177,014. KAPOW TECHNOLOGIES HOLDINGS, INC.,  
PALO ALTO, CA. FILED 11-15-2010.

# FUNUN

THE MARK CONSISTS OF STANDARD CHARACTERS WITHOUT CLAIM TO ANY PARTICULAR FONT, STYLE, SIZE, OR COLOR.

## **CLASS 16—PAPER GOODS AND PRINTED MATTER**

FOR SIGNS MADE OF PAPER OR CARDBOARD, BUMPER STICKERS, GREETING CARDS, WINDOW DECALS (U.S. CLS. 2, 5, 22, 23, 29, 37, 38 AND 50).

## **CLASS 25—CLOTHING**

FOR CLOTHING, NAMELY T-SHIRTS, SWEAT-SHIRTS, SWEAT PANTS, SHORTS, HATS, BASEBALL CAPS (U.S. CLS. 22 AND 39).

## **CLASS 26—FANCY GOODS**

FOR PIN-BACKED BUTTONS (U.S. CLS. 37, 39, 40, 42 AND 50).  
JANICE L. MCMORROW, EXAMINING ATTORNEY

---

SN 85-177,000. 621SHOP LLC, UPPER MARLBORO, MD.  
FILED 11-15-2010.

# 6:21

THE MARK CONSISTS OF STANDARD CHARACTERS WITHOUT CLAIM TO ANY PARTICULAR FONT, STYLE, SIZE, OR COLOR.

## **CLASS 16—PAPER GOODS AND PRINTED MATTER**

FOR SIGNS MADE OF PAPER OR CARDBOARD, BUMPER STICKERS, GREETING CARDS, WINDOW DECALS (U.S. CLS. 2, 5, 22, 23, 29, 37, 38 AND 50).

## **CLASS 25—CLOTHING**

FOR CLOTHING, NAMELY T-SHIRTS, SWEAT-SHIRTS, SWEAT PANTS, SHORTS, HATS, BASEBALL CAPS (U.S. CLS. 22 AND 39).

## **CLASS 26—FANCY GOODS**

FOR PIN-BACKED BUTTONS (U.S. CLS. 37, 39, 40, 42 AND 50).  
JANICE L. MCMORROW, EXAMINING ATTORNEY

# KAPOW KATALYST

THE MARK CONSISTS OF STANDARD CHARACTERS WITHOUT CLAIM TO ANY PARTICULAR FONT, STYLE, SIZE, OR COLOR.  
OWNER OF U.S. REG. NOS. 3,807,693 AND 3,807,694.

## **CLASS 9—ELECTRICAL AND SCIENTIFIC APPARATUS**

FOR COMPUTER SOFTWARE FOR USE IN ACCESSING, TRANSFORMING, SEARCHING, COMPILING, INDEXING, CONNECTING, COLLECTING, COMBINING, ORGANIZING AND MANIPULATING FROM MULTIPLE SOURCES DATA, MULTIMEDIA CONTENT, INFORMATION AND BUSINESS INTELLIGENCE ON THE INTERNET INTO USABLE FORM; COMPUTER SOFTWARE FOR CREATING INDEXES OF INFORMATION, WEB SITES, AND OTHER INFORMATION RESOURCES; COMPUTER SOFTWARE FOR ENHANCING THE CAPABILITIES OF WEB BROWSER SOFTWARE; CUSTOMIZABLE COMPUTER WEB BROWSER SOFTWARE FOR ACCESSING, CREATING, COLLECTING, STORING, REMOVING, TRANSFERRING, DISSEMINATING, ORGANIZING, AND SEARCHING TEXT, GRAPHICS OR OTHER DATA; CUSTOMIZABLE COMPUTER SOFTWARE FOR ACCESSING, CREATING, COLLECTING, STORING, REMOVING, TRANSFERRING, DISSEMINATING, ORGANIZING, AND SEARCHING DATA OVER A GLOBAL COMPUTER NETWORK AND OTHER NETWORKS; COMPUTER SOFTWARE FOR UPDATING AND INTEGRATING DATA, USER SPECIFICATIONS AND NETWORK SPECIFICATIONS OVER WIRELESS AND WIRELINE NETWORKS; COMPUTER SOFTWARE FOR INTEGRATING WEB TECHNOLOGIES; COMPUTER SOFTWARE FOR DEVELOPING AND PROGRAMMING INTERACTIVE MOBILE AND EMBEDDED APPLICATIONS; AND INSTRUCTIONAL MANUALS, SOLD AS A UNIT (U.S. CLS. 21, 23, 26, 36 AND 38).

## **CLASS 38—COMMUNICATION**

FOR TELECOMMUNICATION SERVICES, NAMELY, RENTAL OF ACCESS TIME TO GLOBAL COMPUTER NETWORKS, AND PROVIDING ONLINE ACCESS TO DATABASES; PROVIDING MULTIPLE USER ACCESS TO PROPRIETARY COLLECTIONS OF INFORMATION BY MEANS OF GLOBAL COMPUTER INFORMATION NETWORKS (U.S. CLS. 100, 101 AND 104).

**CLASS 42—SCIENTIFIC AND COMPUTER SERVICES**

FOR COMPUTER SOFTWARE CONSULTATION SERVICES; COMPUTER CONSULTANCY IN THE FIELDS OF DATABASES, WEB BROWSERS, WEB SITES AND WEB HOSTING SERVICES AND PROGRAMMING COMPUTER SERVICES, NAMELY, PROVIDING SOFTWARE INTERFACES AVAILABLE OVER A COMPUTER NETWORK IN ORDER FOR USERS TO CREATE A PERSONALIZED ON-LINE INFORMATION AND DATA RETRIEVAL AND COLLECTION SERVICE; COMPUTER SERVICE, NAMELY, ACTING AS AN APPLICATION SERVICE PROVIDER IN THE FIELD OF KNOWLEDGE MANAGEMENT TO HOST COMPUTER APPLICATION SOFTWARE FOR THE COLLECTION, EDITING, ORGANIZING, MODIFYING, BOOK MARKING, TRANSMISSION, STORAGE AND SHARING OF DATA AND INFORMATION; DATA MINING, NAMELY, COLLECTION AND RETRIEVAL OF INFORMATION BY MEANS OF GLOBAL COMPUTER NETWORKS; CREATING INDEXES OF INFORMATION, WEB SITES AND OTHER INFORMATION SOURCES IN CONNECTION WITH GLOBAL COMPUTER NETWORKS; PROVIDING INFORMATION AT THE SPECIFIC REQUEST OF END-USERS BY MEANS OF GLOBAL COMPUTER INFORMATION NETWORKS; PROVIDING ONLINE NON-DOWNLOADABLE COMPUTER SOFTWARE FOR USE IN SEARCHING, COMPILING, INDEXING, CONNECTING, COLLECTING, COMBINING AND ORGANIZING FROM MULTIPLE SOURCES DATA, MULTIMEDIA CONTENT, INFORMATION AND BUSINESS INTELLIGENCE ON THE INTERNET AND FOR USE IN CREATING INDEXES OF INFORMATION, WEB SITES AND OTHER INFORMATION RESOURCES (U.S. CLS. 100 AND 101).

TRACY CROSS, EXAMINING ATTORNEY

**CLASS 41—EDUCATION AND ENTERTAINMENT**

FOR EDUCATIONAL SERVICES, NAMELY, PROVIDING SEMINARS, WORKSHOPS AND CONTINUED EDUCATION COURSES IN THE FIELDS OF PRODUCTIVITY, PROACTIVE LIFESTYLES, AND FITNESS; PERSONAL TRAINING PROVIDED IN CONNECTION WITH WEIGHT LOSS AND EXERCISE PROGRAMS; PERSONAL TRAINING SERVICES, NAMELY, STRENGTH AND CONDITIONING TRAINING; PROVIDING ASSISTANCE, PERSONAL TRAINING AND PHYSICAL FITNESS CONSULTATION TO CORPORATE CLIENTS TO HELP THEIR EMPLOYEES MAKE PHYSICAL FITNESS, STRENGTH, CONDITIONING, AND EXERCISE ALTERATIONS IN THEIR DAILY LIVING; PROVIDING ASSISTANCE, PERSONAL TRAINING AND PHYSICAL FITNESS CONSULTATION TO INDIVIDUALS TO HELP THEM MAKE PHYSICAL FITNESS, STRENGTH, CONDITIONING, AND EXERCISE IMPROVEMENT IN THEIR DAILY LIVING (U.S. CLS. 100, 101 AND 107).

FIRST USE 11-2-2009; IN COMMERCE 11-2-2009.

ANDREA HACK, EXAMINING ATTORNEY

SN 85-177,208. RPR HOLDING GMBH, BERLIN, FED REP GERMANY, FILED 11-15-2010.

SN 85-177,043. SNIEWSKI, LUKE, SANTA MONICA, CA. FILED 11-15-2010.

**LEAF**

THE MARK CONSISTS OF STANDARD CHARACTERS WITHOUT CLAIM TO ANY PARTICULAR FONT, STYLE, SIZE, OR COLOR.

**CLASS 9—ELECTRICAL AND SCIENTIFIC APPARATUS**

FOR DVDS FEATURING INSTRUCTION IN THE AREA OF FITNESS (U.S. CLS. 21, 23, 26, 36 AND 38).

**ByClick**

THE MARK CONSISTS OF STANDARD CHARACTERS WITHOUT CLAIM TO ANY PARTICULAR FONT, STYLE, SIZE, OR COLOR.

**CLASS 35—ADVERTISING AND BUSINESS**

FOR ON-LINE AUCTION SERVICES; ON-LINE TRADING SERVICES IN WHICH SELLER POSTS PRODUCTS TO BE AUCTIONED AND BIDDING IS DONE VIA THE INTERNET; PROVIDING A WEB SITE WHERE USERS CAN POST ITEMS FOR SALE THROUGH ON-LINE CLASSIFIED ADVERTISEMENTS; PROVIDING A WEB SITE THAT FEATURES AN ON-LINE MARKET FOR USERS TO LIST OFFERED OR WANTED PERSONAL AND BUSINESS ASSETS AND SKILLS FOR HIRE, RENT, SALE OR AUCTION TRANSACTED ON THE BASIS OF PREDEFINED PERFORMANCE AND CLOSING TERMS AND CONDITIONS (U.S. CLS. 100, 101 AND 102).

**CLASS 41—EDUCATION AND ENTERTAINMENT**

FOR ON-LINE LOTTERY AND RAFFLE SERVICES (U.S. CLS. 100, 101 AND 107).

LINDA ORNDORFF, EXAMINING ATTORNEY

SN 85-177,268. SYSTEMS AND PROPOSAL ENGINEERING COMPANY, MARSHALL, VA. FILED 11-15-2010.

## ZEODIN

THE MARK CONSISTS OF STANDARD CHARACTERS WITHOUT CLAIM TO ANY PARTICULAR FONT, STYLE, SIZE, OR COLOR.

### CLASS 9—ELECTRICAL AND SCIENTIFIC APPARATUS

FOR COMPUTER SOFTWARE FOR THE ANALYSIS AND DESIGN OF ARCHITECTURE (U.S. CLS. 21, 23, 26, 36 AND 38).

### CLASS 42—SCIENTIFIC AND COMPUTER SERVICES

FOR DESIGN AND DEVELOPMENT OF COMPUTER SOFTWARE; PROVIDING TEMPORARY USE OF ON-LINE NONDOWNLOADABLE SOFTWARE AND APPLICATIONS FOR THE ANALYSIS AND DESIGN OF ARCHITECTURE (U.S. CLS. 100 AND 101).  
SANJEEV VOHRA, EXAMINING ATTORNEY

SN 85-177,278. INFINITE VENTURES, INC., SAN CLEMENTE, CA. FILED 11-15-2010.

## Sani-Paws

THE MARK CONSISTS OF STANDARD CHARACTERS WITHOUT CLAIM TO ANY PARTICULAR FONT, STYLE, SIZE, OR COLOR.

### CLASS 21—HOUSEWARES AND GLASS

FOR ANIMAL LITTER BOXES (U.S. CLS. 2, 13, 23, 29, 30, 33, 40 AND 50).

### CLASS 28—TOYS AND SPORTING GOODS

FOR DOG TOYS (U.S. CLS. 22, 23, 38 AND 50).  
BRENDAN REGAN, EXAMINING ATTORNEY

SN 85-177,372. CHRISTIAN JAMES BAUER, DBA THE DUDE WHISPERER OR THE DW, ALAMEDA, CA. FILED 11-15-2010.

## The Dude Whisperer

THE MARK CONSISTS OF STANDARD CHARACTERS WITHOUT CLAIM TO ANY PARTICULAR FONT, STYLE, SIZE, OR COLOR.

### CLASS 16—PAPER GOODS AND PRINTED MATTER

FOR SYNDICATED COLUMNS DEALING WITH ADVICE (U.S. CLS. 2, 5, 22, 23, 29, 37, 38 AND 50).

### CLASS 41—EDUCATION AND ENTERTAINMENT

FOR ENTERTAINMENT SERVICES, NAMELY, PROVIDING A WEBSITE AT WHICH THE GENERAL PUBLIC CAN RECEIVE ADVICE FROM AN INDIVIDUAL CONCERNING RELATIONSHIPS, SUCH ADVICE BEING FOR ENTERTAINMENT PURPOSES ONLY (U.S. CLS. 100, 101 AND 107).

FIRST USE 2-15-2008; IN COMMERCE 2-15-2008.  
KEVIN CORWIN, EXAMINING ATTORNEY

SN 85-177,377. C.O.R.E.X S.P.A. S.S., SALERNO, ITALY, FILED 11-16-2010.

## PASTASI

THE MARK CONSISTS OF STANDARD CHARACTERS WITHOUT CLAIM TO ANY PARTICULAR FONT, STYLE, SIZE, OR COLOR.

### CLASS 29—MEATS AND PROCESSED FOODS

FOR CANNED TOMATOES, OLIVE OIL (U.S. CL. 46).  
FIRST USE 7-1-2003; IN COMMERCE 7-1-2003.

### CLASS 30—STAPLE FOODS

FOR PASTA SAUCES, PASTAS, BALSAMIC VINEGAR (U.S. CL. 46).  
FIRST USE 7-1-2003; IN COMMERCE 7-1-2003.  
CARYN GLASSER, EXAMINING ATTORNEY

SN 85-177,501. FEARLESS FIGHTING INC., GREENVILLE, NC. FILED 11-16-2010.

## EXPERIENCE VICTORY

THE MARK CONSISTS OF STANDARD CHARACTERS WITHOUT CLAIM TO ANY PARTICULAR FONT, STYLE, SIZE, OR COLOR.

### CLASS 25—CLOTHING

FOR HATS; SHIRTS; SHORTS; SWEAT PANTS; SWEAT SHIRTS; TANK TOPS (U.S. CLS. 22 AND 39).  
FIRST USE 5-4-2009; IN COMMERCE 5-4-2009.

### CLASS 41—EDUCATION AND ENTERTAINMENT

FOR MARTIAL ARTS INSTRUCTION (U.S. CLS. 100, 101 AND 107).  
FIRST USE 5-4-2009; IN COMMERCE 5-4-2009.  
TOBY BULLOFF, EXAMINING ATTORNEY

SN 85-177,522. PATTI, THOMAS J, DBA TOM PATTI DESIGN, PITTSFIELD, MA. AND PATTI, MARILYN HOLTZ, DBA TOM PATTI DESIGN, PITTSFIELD, MA. FILED 11-16-2010.

# VITRUGLAS

THE MARK CONSISTS OF STANDARD CHARACTERS WITHOUT CLAIM TO ANY PARTICULAR FONT, STYLE, SIZE, OR COLOR.

## CLASS 9—ELECTRICAL AND SCIENTIFIC APPARATUS

FOR BULLET-PROOF GLASS; BULLET-RESISTANT GLASS (U.S. CLS. 21, 23, 26, 36 AND 38).

## CLASS 19—NON-METALLIC BUILDING MATERIALS

FOR DECORATIVE GLASS; LAMINATED FLAT GLASS; WINDOW GLASS (U.S. CLS. 1, 12, 33 AND 50).

## CLASS 21—HOUSEWARES AND GLASS

FOR DECORATIVE GLASS; LAMINATED FLAT GLASS; LUMINOUS GLASS; SEMI-FINISHED SAFETY GLASS; WINDOW GLASS FOR VEHICLES; WORKS OF ART MADE OF GLASS (U.S. CLS. 2, 13, 23, 29, 30, 33, 40 AND 50).

THEODORE MCBRIDE, EXAMINING ATTORNEY

SN 85-177,548. BROWN UNIVERSITY, PROVIDENCE, RI. FILED 11-16-2010.



THE MARK CONSISTS OF BEAR HEAD.

## CLASS 16—PAPER GOODS AND PRINTED MATTER

FOR DECALS; POSTCARDS; STATIONERY; STICKERS; WRITING INSTRUMENTS (U.S. CLS. 2, 5, 22, 23, 29, 37, 38 AND 50).

FIRST USE 10-31-1997; IN COMMERCE 10-31-1997.

## CLASS 24—FABRICS

FOR FELT PENNANTS (U.S. CLS. 42 AND 50). FIRST USE 10-31-1997; IN COMMERCE 10-31-1997.

## CLASS 25—CLOTHING

FOR BIB OVERALLS; BOOTIES; FOOTWEAR; HATS; JACKETS; SHORTS; SOCKS; SWEATPANTS; SWEATSHIRTS; T-SHIRTS; TIES (U.S. CLS. 22 AND 39). FIRST USE 10-31-1997; IN COMMERCE 10-31-1997. BRENDAN REGAN, EXAMINING ATTORNEY

SN 85-177,677. ROCK AND RESCUE, SHERMAN OAKS, CA. FILED 11-16-2010.

## Rock and Rescue. Sex, Dogs and Rock and (and/or N') Roll.

THE MARK CONSISTS OF STANDARD CHARACTERS WITHOUT CLAIM TO ANY PARTICULAR FONT, STYLE, SIZE, OR COLOR.

## CLASS 6—METAL GOODS

FOR METAL KEY RINGS (U.S. CLS. 2, 12, 13, 14, 23, 25 AND 50).

## CLASS 14—JEWELRY

FOR JEWELRY; KEY RINGS OF PRECIOUS METALS; NECKLACES (U.S. CLS. 2, 27, 28 AND 50).

## CLASS 18—LEATHER GOODS

FOR DOG CLOTHING; DOG COLLARS; DOG LEASHES; HARNESSES; PET COLLAR ACCESSORIES, NAMELY, CHARMS (U.S. CLS. 1, 2, 3, 22 AND 41).

## CLASS 20—FURNITURE AND ARTICLES NOT OTHERWISE CLASSIFIED

FOR NON-METAL KEY RINGS; PLASTIC KEY RINGS (U.S. CLS. 2, 13, 22, 25, 32 AND 50).

## CLASS 21—HOUSEWARES AND GLASS

FOR PLASTIC CUPS; PLASTIC WATER BOTTLES SOLD EMPTY (U.S. CLS. 2, 13, 23, 29, 30, 33, 40 AND 50).

## CLASS 25—CLOTHING

FOR HATS; T-SHIRTS (U.S. CLS. 22 AND 39).

## CLASS 35—ADVERTISING AND BUSINESS

FOR PROMOTING PUBLIC AWARENESS OF THE NEED FOR ANIMAL RESCUE (U.S. CLS. 100, 101 AND 102).

## CLASS 36—INSURANCE AND FINANCIAL

FOR CHARITABLE SERVICES, NAMELY, ORGANIZING FUNDRAISING SERVICES AND EVENTS TO RAISE FUNDS IN THE FIELD OF ANIMAL RESCUE (U.S. CLS. 100, 101 AND 102).

ELLEN PERKINS, EXAMINING ATTORNEY

SN 85-177,705. LIFEALIKE LIMITED, LONDON, EC1Y 4UP, UNITED KINGDOM. FILED 11-16-2010.

## ONEFINESTAY

THE MARK CONSISTS OF STANDARD CHARACTERS WITHOUT CLAIM TO ANY PARTICULAR FONT, STYLE, SIZE, OR COLOR.

OWNER OF UNITED KINGDOM REG. NO. 2538736, DATED 5-28-2010, EXPIRES 2-5-2020.

### CLASS 35—ADVERTISING AND BUSINESS

FOR (BASED ON INTENT TO USE) ADVERTISING ON THE INTERNET FOR OTHERS; ADVERTISING SERVICES; ADVERTISING VIA ELECTRONIC MEDIA AND SPECIFICALLY THE INTERNET; INTERNET ADVERTISING SERVICES; ON-LINE BUYERS GUIDE SERVICE PROVIDING INFORMATION IN THE FIELD OF PRIVATE RESIDENTIAL PROPERTIES THAT ARE AVAILABLE FOR TEMPORARY ACCOMMODATIONS AND LISTING OF PRIVATE ACCOMMODATION FOR RENTAL PURPOSES; PROMOTING THE GOODS AND SERVICES OF OTHERS BY PROVIDING A WEB SITE AT WHICH USERS CAN LINK TO VIEW GUEST REVIEWS OF TEMPORARY ACCOMMODATION AND MAKE BOOKING AND RESERVATIONS OF PRIVATE ACCOMMODATION; PROMOTING THE GOODS AND SERVICES OF OTHERS VIA A GLOBAL COMPUTER NETWORK; PROVIDING A SEARCHABLE ONLINE ADVERTISING WEBSITE AND INFORMATIONAL GUIDE FEATURING THE GOODS AND SERVICES OF OTHER VENDORS VIA THE INTERNET IN THE FIELD OF TEMPORARY ACCOMMODATION AND PRIVATE RESIDENTIAL PROPERTIES FOR TEMPORARY STAY; PROVIDING AN ON-LINE DIRECTORY INFORMATION SERVICE FEATURING INFORMATION REGARDING PRIVATE RESIDENTIAL PROPERTIES THAT ARE AVAILABLE FOR TEMPORARY ACCOMMODATIONS FOR OTHERS; PROVIDING CONSUMER INFORMATION IN THE FIELD OF TEMPORARY ACCOMMODATIONS FEATURING PRIVATE RESIDENTIAL PROPERTIES THAT ARE AVAILABLE FOR RENT; PROVIDING CONSUMER INFORMATION IN THE FIELD OF CLASSIFIED ADVERTISING SPACE FOR TEMPORARY ACCOMMODATIONS BY MEANS OF THE INTERNET(BASED ON 44(E)) ADVERTISING ON THE INTERNET FOR OTHERS; ADVERTISING SERVICES; ADVERTISING VIA ELECTRONIC MEDIA AND SPECIFICALLY THE INTERNET; INTERNET ADVERTISING SERVICES; ON-LINE BUYERS GUIDE SERVICE PROVIDING INFORMATION IN THE FIELD OF PRIVATE RESIDENTIAL PROPERTIES THAT ARE AVAILABLE FOR TEMPORARY ACCOMMODATIONS AND LISTING OF PRIVATE ACCOMMODATION FOR RENTAL PURPOSES; PROMOTING THE GOODS AND SERVICES OF OTHERS BY PROVIDING A WEB SITE AT WHICH USERS CAN LINK TO VIEW GUEST REVIEWS OF TEMPORARY ACCOMMODATION AND MAKE BOOKING AND RESERVATIONS OF PRIVATE ACCOMMODATION; PROMOTING THE GOODS AND SERVICES OF OTHERS VIA A GLOBAL COMPUTER NETWORK; PROVIDING A SEARCHABLE ONLINE ADVERTISING WEBSITE AND INFORMATIONAL GUIDE FEATURING THE GOODS AND SERVICES OF OTHER VENDORS VIA THE INTERNET IN THE FIELD OF TEMPORARY ACCOMMODATION AND PRIVATE RESIDENTIAL PROPERTIES FOR TEMPORARY STAY; PROVIDING AN ON-LINE DIRECTORY INFORMATION SERVICE FEATURING INFORMATION REGARDING PRIVATE RESIDENTIAL PROPERTIES THAT ARE AVAILABLE FOR TEMPORARY ACCOMMODATIONS FOR OTHERS; PROVIDING CONSUMER INFORMATION IN THE FIELD OF TEMPORARY ACCOMMODATIONS FEATURING PRIVATE RESIDENTIAL PROPERTIES THAT ARE AVAILABLE FOR RENT; PROVIDING CONSUMER INFORMATION IN THE FIELD OF CLASSIFIED ADVERTISING SPACE FOR TEMPORARY ACCOMMODATIONS BY MEANS OF THE INTERNET (U.S. CLS. 100, 101 AND 102).

### CLASS 43—HOTEL AND RESTAURANT SERVICES

FOR (BASED ON INTENT TO USE) AGENCY SERVICES FOR THE RESERVATION OF TEMPORARY ACCOMMODATION; ARRANGING TEMPORARY HOUSING ACCOMMODATIONS; HOTEL ACCOMMODATION SERVICES; PROVIDING PERSONALIZED INFORMATION ABOUT HOTELS AND TEMPORARY ACCOMMODATIONS FOR TRAVEL VIA THE INTERNET; PROVIDING TEMPORARY ACCOMMODATION; PROVIDING TEMPORARY HOUSING ACCOMMODATIONS; PROVIDING TRAVEL LODGING INFORMATION SERVICES AND TRAVEL LODGING BOOKING AGENCY SERVICES FOR TRAVELERS; RENTAL OF PRIVATE MANSIONS AS TEMPORARY LIVING ACCOMMODATIONS FOR VACATION STAYS; RENTAL OF ROOMS AS TEMPORARY LIVING ACCOMMODATIONS; RESERVATION OF ROOMS FOR TRAVELLERS; SERVICES FOR THE RESERVATION OF ROOMS(BASED ON 44(E)) AGENCY SERVICES FOR THE RESERVATION OF TEMPORARY ACCOMMODATION; ARRANGING TEMPORARY HOUSING ACCOMMODATIONS; HOTEL ACCOMMODATION SERVICES; PROVIDING PERSONALIZED INFORMATION ABOUT HOTELS AND TEMPORARY ACCOMMODATIONS FOR TRAVEL VIA THE INTERNET; PROVIDING TEMPORARY ACCOMMODATION; PROVIDING TEMPORARY HOUSING ACCOMMODATIONS; PROVIDING TRAVEL LODGING INFORMATION SERVICES AND TRAVEL LODGING BOOKING AGENCY SERVICES FOR TRAVELERS; RENTAL OF PRIVATE MANSIONS AS TEMPORARY LIVING ACCOMMODATIONS FOR VACATION STAYS; RENTAL OF ROOMS AS TEMPORARY LIVING ACCOMMODATIONS; RESERVATION OF ROOMS FOR TRAVELLERS; SERVICES FOR THE RESERVATION OF ROOMS (U.S. CLS. 100 AND 101).

DAWN FELDMAN, EXAMINING ATTORNEY

SN 85-177,712. AMERICAN HEART ASSOCIATION, DALLAS, TX. FILED 11-16-2010.

## Most Powerful Voices

THE MARK CONSISTS OF STANDARD CHARACTERS WITHOUT CLAIM TO ANY PARTICULAR FONT, STYLE, SIZE, OR COLOR.

### CLASS 35—ADVERTISING AND BUSINESS

FOR PROMOTING PUBLIC AWARENESS OF STROKE (U.S. CLS. 100, 101 AND 102).  
FIRST USE 1-31-2009; IN COMMERCE 1-31-2009.

### CLASS 41—EDUCATION AND ENTERTAINMENT

FOR PROVIDING A WEB SITE THAT FEATURES INFORMAL INSTRUCTION ON STROKE (U.S. CLS. 100, 101 AND 107).  
FIRST USE 1-31-2009; IN COMMERCE 1-31-2009.  
JESSICA FATHY, EXAMINING ATTORNEY



SN 85-177,778. BUNCÉE LLC, MATTITUCK, NY. FILED 11-16-2010.

# BUNCÉE

THE MARK CONSISTS OF STANDARD CHARACTERS WITHOUT CLAIM TO ANY PARTICULAR FONT, STYLE, SIZE, OR COLOR.

**CLASS 9—ELECTRICAL AND SCIENTIFIC APPARATUS**

FOR COMPUTER SOFTWARE FOR ENABLING AND PROVIDING AN INTERNET BASED SERVICE THAT ALLOWS USERS TO SHARE MEDIA AND COMMUNICATE ACROSS A SOCIAL NETWORK (U.S. CLS. 21, 23, 26, 36 AND 38).

**CLASS 45—PERSONAL AND LEGAL SERVICES**

FOR PROVIDING AN INTERACTIVE SOCIAL NETWORKING WEBSITE ALLOWING USERS TO SHARE MEDIA AND COMMUNICATE, FOR ENTERTAINMENT PURPOSES (U.S. CLS. 100 AND 101).  
WENDY JUN, EXAMINING ATTORNEY

SN 85-177,791. BIJORA, INC., DBA AKIRA, CHICAGO, IL. FILED 11-16-2010.

# AKIRA

THE MARK CONSISTS OF STANDARD CHARACTERS WITHOUT CLAIM TO ANY PARTICULAR FONT, STYLE, SIZE, OR COLOR.  
THE ENGLISH TRANSLATION OF AKIRA IN THE MARK IS BRIGHTNESS OR MORNING SUNSHINE.

**CLASS 32—LIGHT BEVERAGES**

FOR BEER (U.S. CLS. 45, 46 AND 48).

**CLASS 33—WINES AND SPIRITS**

FOR ALCOHOLIC BEVERAGES EXCEPT BEERS (U.S. CLS. 47 AND 49).  
LAURIE MAYES, EXAMINING ATTORNEY

SN 85-177,813. BUNCÉE LLC, MATTITUCK, NY. FILED 11-16-2010.



THE MARK CONSISTS OF THE STYLIZED TERM "BUNCÉE" HAVING A TEARDROP AT THE END THEREOF.

**CLASS 9—ELECTRICAL AND SCIENTIFIC APPARATUS**

FOR COMPUTER SOFTWARE FOR ENABLING AND PROVIDING AN INTERNET BASED SERVICE THAT ALLOWS USERS TO SHARE MEDIA AND COMMUNICATE ACROSS A SOCIAL NETWORK (U.S. CLS. 21, 23, 26, 36 AND 38).

**CLASS 45—PERSONAL AND LEGAL SERVICES**

FOR PROVIDING AN INTERACTIVE SOCIAL NETWORKING WEBSITE ALLOWING USERS TO SHARE MEDIA AND COMMUNICATE, FOR ENTERTAINMENT PURPOSES (U.S. CLS. 100 AND 101).  
WENDY JUN, EXAMINING ATTORNEY

SN 85-177,826. BUNCÉE LLC, MATTITUCK, NY. FILED 11-16-2010.



THE MARK CONSISTS OF A STYLIZED LOWERCASE LETTER "B" HAVING A TEARDROP SHAPED INSIDE PORTION. THE LETTER IS INSIDE A SHADED SQUARE WITH ROUNDED CORNERS.

**CLASS 9—ELECTRICAL AND SCIENTIFIC APPARATUS**

FOR COMPUTER SOFTWARE FOR ENABLING AND PROVIDING AN INTERNET BASED SERVICE THAT ALLOWS USERS TO SHARE MEDIA AND COMMUNICATE ACROSS A SOCIAL NETWORK (U.S. CLS. 21, 23, 26, 36 AND 38).

**CLASS 45—PERSONAL AND LEGAL SERVICES**

FOR PROVIDING AN INTERACTIVE SOCIAL NETWORKING WEBSITE ALLOWING USERS TO SHARE MEDIA AND COMMUNICATE, FOR ENTERTAINMENT PURPOSES (U.S. CLS. 100 AND 101).  
WENDY JUN, EXAMINING ATTORNEY

SN 85-178,019. NIKE, INC., BEAVERTON, OR. FILED 11-16-2010.

ERIN FALK, EXAMINING ATTORNEY



OWNER OF U.S. REG. NO. 3,854,206.  
THE MARK CONSISTS OF A STYLIZED LETTER "N"  
AND STYLIZED NUMBER "7" WITHIN A CIRCLE.

**CLASS 18—LEATHER GOODS**

FOR BAGS, NAMELY, ALL-PURPOSE SPORTS BAGS, TOTE BAGS, DUFFLE BAGS, MESSENGER BAGS, BACKPACKS, PURSES, BAGS FOR CARRYING SHOES (U.S. CLS. 1, 2, 3, 22 AND 41).

**CLASS 25—CLOTHING**

FOR FOOTWEAR, SHIRTS, T-SHIRTS (U.S. CLS. 22 AND 39).  
ERNEST SHOSHO, EXAMINING ATTORNEY

SN 85-178,029. REDNOTE LLC, MILTON, MA. FILED 11-16-2010.

**Rednote**

THE MARK CONSISTS OF STANDARD CHARACTERS WITHOUT CLAIM TO ANY PARTICULAR FONT, STYLE, SIZE, OR COLOR.

**CLASS 9—ELECTRICAL AND SCIENTIFIC APPARATUS**

FOR DOWNLOADABLE RING TONES, GRAPHICS AND MUSIC VIA A GLOBAL COMPUTER NETWORK AND WIRELESS DEVICES (U.S. CLS. 21, 23, 26, 36 AND 38).

**CLASS 38—COMMUNICATION**

FOR DELIVERY OF DIGITAL MUSIC BY ELECTRONIC TRANSMISSION (U.S. CLS. 100, 101 AND 104).

**CLASS 41—EDUCATION AND ENTERTAINMENT**

FOR ENTERTAINMENT SERVICES, NAMELY, NON-DOWNLOADABLE RINGTONES, PRE-RECORDED MUSIC, AND GRAPHICS PRESENTED TO MOBILE COMMUNICATIONS DEVICES VIA A GLOBAL COMPUTER NETWORK AND WIRELESS NETWORKS (U.S. CLS. 100, 101 AND 107).

SN 85-178,032. RESPITE—LINK, CORP., ALOHA, OR. FILED 11-16-2010.



THE MARK CONSISTS OF A GLOBE ENCLOSED INSIDE TWO INTERSECTING CHAIN LINKS AND THREE CONNECTED STYLIZED HUMAN FIGURES AROUND THE GLOBE.

**CLASS 35—ADVERTISING AND BUSINESS**

FOR BARTER EXCHANGE SERVICES, NAMELY, PROVIDING COMMERCIAL BARTER AND TRADE EXCHANGE OF PRODUCTS AND SERVICES VIA A GLOBAL COMPUTER INFORMATION NETWORK; MATCHING CONSUMERS WITH PROFESSIONALS IN THE FIELD OF RESIDENTIAL AND COMMERCIAL SERVICES VIA COMPUTER NETWORK; ONLINE SERVICE FOR CONNECTING SOCIAL NETWORK USERS WITH RETAILERS FOR THE PURPOSE OF FACILITATING DISCOUNTED PURCHASES; PROMOTING THE GOODS AND SERVICES OF OTHERS BY PROVIDING A COMMUNITY-DRIVEN WEB SITE FEATURING USER-SUBMITTED CONTENT IN THE NATURE OF COUPONS, REBATES, PRICE-COMPARISON INFORMATION, PRODUCT REVIEWS, LINKS TO THE RETAIL WEB SITES OF OTHERS, AND DISCOUNT INFORMATION; PROMOTING THE GOODS AND SERVICES OF OTHERS BY PROVIDING A WEB SITE FEATURING COUPONS, REBATES, PRICE-COMPARISON INFORMATION, PRODUCT REVIEWS, LINKS TO THE RETAIL WEB SITES OF OTHERS, AND DISCOUNT INFORMATION; PROMOTING THE SALE OF GOODS AND SERVICES OF OTHERS THROUGH ELECTRONIC COUPONING, PROMOTIONS AND DISCOUNTS; PROVIDING A WEBSITE FOR USERS WITH SPECIFIC INFORMED RECOMMENDATIONS OF SPECIFIC CONSUMER PRODUCTS AND SERVICES VALIDATED BY THE USERS' INPUTTED PREFERENCES AND SOCIAL NETWORK; PROVIDING INFORMATION ABOUT THE GOODS AND SERVICES OF OTHERS VIA THE GLOBAL COMPUTER NETWORK (U.S. CLS. 100, 101 AND 102).

**CLASS 42—SCIENTIFIC AND COMPUTER SERVICES**

FOR COMPUTER SERVICES, NAMELY, CREATING AN ON-LINE COMMUNITY FOR REGISTERED USERS TO PARTICIPATE IN DISCUSSIONS, GET FEEDBACK FROM THEIR PEERS, FORM VIRTUAL COMMUNITIES, AND ENGAGE IN SOCIAL NETWORKING FEATURING PRODUCTS, SERVICES, SUPPORT, RESOURCES AND RATINGS; PROVIDING A WEBSITE FEATURING TECHNOLOGY THAT ENABLES USERS TO CONNECT WITH OTHER PEOPLE IN THEIR NEIGHBORHOOD OR CITY FOR ANY NUMBER OF USER-SPECIFIED REASONS, INCLUDING PROVIDING A SERVICE OR ORGANIZING AN EVENT; PROVIDING AN ONLINE NETWORK SERVICE THAT ENABLES USERS TO SHARE DATA IN THE FIELD OF PERSONAL, BUSINESS, AND FAMILY SUPPORT AND CONNECTIONS THROUGH RESOURCE NETWORKING; PROVIDING CUSTOMER-DEFINED GENERATED CONTENT AND CONTENT OF OTHERS AUTOMATICALLY SELECTED AND CUSTOMIZED BASED ON THE KNOWN OR ESTIMATED GEOGRAPHICAL LOCATION OF AN INTERNET, MOBILE TELEPHONE OR OTHER WIRED OR WIRELESS DIGITAL NETWORK BASEDCUSTOMER (U.S. CLS. 100 AND 101).

**CLASS 45—PERSONAL AND LEGAL SERVICES**

FOR INTERNET-BASED SOCIAL NETWORKING SERVICES; ON-LINE SOCIAL NETWORKING SERVICES; PROVIDING ON-LINE COMPUTER DATABASES AND ON-LINE SEARCHABLE DATABASES IN THE FIELD OF SOCIAL NETWORKING (U.S. CLS. 100 AND 101).  
GENE MACIOL, EXAMINING ATTORNEY

SN 85-178,107. MOON RIVER BREWING COMPANY, LLC, SAVANNAH, GA. FILED 11-16-2010.

MOON RIVER

THE MARK CONSISTS OF STANDARD CHARACTERS WITHOUT CLAIM TO ANY PARTICULAR FONT, STYLE, SIZE, OR COLOR.

**CLASS 32—LIGHT BEVERAGES**

FOR BEER, ALE, LAGER, STOUT AND PORTER; MALT BEER; PALE BEER; FLAVORED BEERS (U.S. CLS. 45, 46 AND 48).  
FIRST USE 9-24-1999; IN COMMERCE 9-24-1999.

**CLASS 43—HOTEL AND RESTAURANT SERVICES**

FOR RESTAURANT AND BREW PUB SERVICES (U.S. CLS. 100 AND 101).  
FIRST USE 4-10-1999; IN COMMERCE 4-10-1999.  
JANICE KIM, EXAMINING ATTORNEY

SN 85-178,433. MEGATRAX PRODUCTION MUSIC, INC., NORTH HOLLYWOOD, CA. FILED 11-16-2010.

THE SOUND OF ENTERTAINMENT

THE MARK CONSISTS OF STANDARD CHARACTERS WITHOUT CLAIM TO ANY PARTICULAR FONT, STYLE, SIZE, OR COLOR.

**CLASS 9—ELECTRICAL AND SCIENTIFIC APPARATUS**

FOR PRE-RECORDED COMPACT DISCS FEATURING MUSIC, AND CD-ROMS FEATURING MUSIC AND CATALOGS OF MUSIC (U.S. CLS. 21, 23, 26, 36 AND 38).

**CLASS 41—EDUCATION AND ENTERTAINMENT**

FOR MAINTAINING A LIBRARY OF RECORDED MUSIC FOR LICENSING PURPOSES; RECORD PRODUCTION SERVICES; MUSIC PUBLISHING SERVICES, PRODUCING AUDIO RECORDINGS OF MUSIC AND SOUND EFFECTS (U.S. CLS. 100, 101 AND 107).  
KHANH LE, EXAMINING ATTORNEY

SN 85-178,462. BARRY CLEVELAND, MIDDLEBURY, VT. FILED 11-16-2010.

eleveneleven

THE MARK CONSISTS OF STANDARD CHARACTERS WITHOUT CLAIM TO ANY PARTICULAR FONT, STYLE, SIZE, OR COLOR.

**CLASS 9—ELECTRICAL AND SCIENTIFIC APPARATUS**

FOR MUSICAL SOUND RECORDINGS; AUDIOVISUAL RECORDINGS FEATURING MUSIC AND MUSICAL BASED ENTERTAINMENT; DOWNLOADABLE MUSICAL SOUND AND DOWNLOADABLE AUDIOVISUAL RECORDINGS FEATURING MUSIC AND MUSICAL BASED ENTERTAINMENT; DOWNLOADABLE RINGTONES, GRAPHICS AND MUSIC VIA A GLOBAL COMPUTER NETWORK AND WIRELESS DEVICES (U.S. CLS. 21, 23, 26, 36 AND 38).

**CLASS 41—EDUCATION AND ENTERTAINMENT**

FOR ENTERTAINMENT SERVICES IN THE NATURE OF RECORDING, PRODUCTION AND POST-PRODUCTION OF MUSIC AND MUSIC VIDEOS; MUSIC PUBLISHING; NON-DOWNLOADABLE PRE-RECORDED MUSIC; PRESENTATION OF LIVE MUSICAL PERFORMANCES (U.S. CLS. 100, 101 AND 107).  
CAROLYN CATALDO, EXAMINING ATTORNEY

SN 85-178,471. LUCASFILM LTD, SAN FRANCISCO, CA.  
FILED 11-16-2010.

# GWIZ

THE MARK CONSISTS OF STANDARD CHARACTERS WITHOUT CLAIM TO ANY PARTICULAR FONT, STYLE, SIZE, OR COLOR.

## CLASS 9—ELECTRICAL AND SCIENTIFIC APPARATUS

FOR COMPUTER SOFTWARE FOR THE CREATION, ANIMATION, VISUALIZATION AND PRE-VISUALIZATION OF 3D MULTIMEDIA CONTENT; COMPUTER SOFTWARE FOR USE IN CREATING, GENERATING, EDITING AND MANIPULATING OF IMAGES, 3D DISPLAYS, GRAPHIC DISPLAYS, AUDIO AND VIDEO BASED ANIMATION AND STILL IMAGES AND GRAPHICS; COMPUTER SOFTWARE FOR STAGING ACTION, ANIMATIONS IN 3D AND 3D DISPLAYS; COMPUTER SOFTWARE FOR THE PRODUCTION AND POST-PRODUCTION OF 3D MULTIMEDIA CONTENTS, FOR THE CREATION OF 3D VIRTUAL REALITY CONTENTS AND 3D SPECIAL EFFECTS (U.S. CLS. 21, 23, 26, 36 AND 38).

## CLASS 41—EDUCATION AND ENTERTAINMENT

FOR ENTERTAINMENT SERVICES, NAMELY, PROVIDING PRE-VISUALIZATION AND VISUALIZATION OF 3D IMAGES, DISPLAYS, GRAPHIC DISPLAYS, AND AUDIO USED FOR MOTION PICTURES, DVDS, INSTRUCTIONAL VIDEOS, COMMERCIALS, TRAILERS, COMPUTER GAMES AND VIDEO GAMES (U.S. CLS. 100, 101 AND 107).

CAROLYN CATALDO, EXAMINING ATTORNEY

SN 85-178,472. LUCASFILM LTD, SAN FRANCISCO, CA.  
FILED 11-16-2010.

# ZVIZ

THE MARK CONSISTS OF STANDARD CHARACTERS WITHOUT CLAIM TO ANY PARTICULAR FONT, STYLE, SIZE, OR COLOR.

## CLASS 9—ELECTRICAL AND SCIENTIFIC APPARATUS

FOR COMPUTER SOFTWARE FOR THE CREATION, ANIMATION, VISUALIZATION AND PRE-VISUALIZATION OF 3D MULTIMEDIA CONTENT; COMPUTER SOFTWARE FOR USE IN CREATING, GENERATING, EDITING AND MANIPULATING OF IMAGES, 3D DISPLAYS, GRAPHIC DISPLAYS, AUDIO AND VIDEO BASED ANIMATION AND STILL IMAGES AND GRAPHICS; COMPUTER SOFTWARE FOR STAGING ACTION, ANIMATIONS IN 3D AND 3D DISPLAYS; COMPUTER SOFTWARE FOR THE PRODUCTION AND POST-PRODUCTION OF 3D MULTIMEDIA CONTENTS, FOR THE CREATION OF 3D VIRTUAL REALITY CONTENTS AND 3D SPECIAL EFFECTS (U.S. CLS. 21, 23, 26, 36 AND 38).

## CLASS 41—EDUCATION AND ENTERTAINMENT

FOR ENTERTAINMENT SERVICES, NAMELY, PROVIDING PRE-VISUALIZATION AND VISUALIZATION OF 3D IMAGES, DISPLAYS, GRAPHIC DISPLAYS, AND AUDIO USED FOR MOTION PICTURES, DVDS, INSTRUCTIONAL VIDEOS, COMMERCIALS, TRAILERS, COMPUTER GAMES AND VIDEO GAMES (U.S. CLS. 100, 101 AND 107).

CAROLYN CATALDO, EXAMINING ATTORNEY

SN 85-178,498. BLITZ DIGITAL STUDIOS, LLC, SANTA MONICA, CA. FILED 11-16-2010.

# We Design Love

THE MARK CONSISTS OF STANDARD CHARACTERS WITHOUT CLAIM TO ANY PARTICULAR FONT, STYLE, SIZE, OR COLOR.

## CLASS 35—ADVERTISING AND BUSINESS

FOR ADVERTISING SERVICES; CREATION AND DISSEMINATION OF ADVERTISING AND MARKETING FOR OTHERS VIA A GLOBAL COMPUTER COMMUNICATIONS NETWORK AND THE INTERNET; ONLINE ADVERTISING AND PROMOTIONS SERVICES, NAMELY, THE DEVELOPMENT OF ADVERTISING PROGRAMS, MARKETING AND PROMOTIONS FOR ADVERTISEMENT ON THE INTERNET AND ONLINE ADVERTISING CAMPAIGNS GENERATING WEBSITE DESTINATIONS, RICH MEDIA AND STANDARD BANNER ADS FOR OTHERS, INCLUDING, E-MAIL CAMPAIGNS, SEARCH ENGINE CAMPAIGNS AND ON-LINE ADVERTISING CAMPAIGNS; PROMOTION AND MARKETING SERVICES, NAMELY, BUSINESS SALES PROMOTIONS, AND RELATED CONSULTING SERVICES; CREATION AND DISSEMINATION OF ONLINE ADVERTISING FOR OTHERS; ADVERTISING AND MARKETING; INTEGRATED MARKETING SERVICES; ADVERTISING AND PUBLICITY SERVICES, NAMELY, PROMOTING THE GOODS, SERVICES, BRAND IDENTITY AND COMMERCIAL INFORMATION AND NEWS OF THIRD PARTIES THROUGH PRINT, AUDIO, VIDEO, MOBILE, KIOSKS, DIGITAL AND ON-LINE MEDIUM; ADVERTISING SERVICES, NAMELY, CREATING CORPORATE AND BRAND IDENTITY FOR OTHERS; BRAND POSITIONING SERVICES; DEVELOPMENT OF MARKETING STRATEGIES, CONCEPTS AND TACTICS, NAMELY, AUDIENCE DEVELOPMENT, BRAND AWARENESS, CUSTOMER RELATIONS, ONLINE COMMUNITY BUILDING AND DIGITAL WORD OF MOUTH COMMUNICATIONS; SOCIAL MEDIA STRATEGY AND MARKETING CONSULTANCY FOCUSING ON HELPING CLIENTS CREATE AND EXTEND THEIR PRODUCT AND BRAND STRATEGIES BY BUILDING ENGAGING MARKETING SOLUTIONS (U.S. CLS. 100, 101 AND 102).

## CLASS 42—SCIENTIFIC AND COMPUTER SERVICES

FOR COMPUTER SOFTWARE DEVELOPMENT IN THE FIELD OF ONLINE AND MOBILE SOFTWARE APPLICATIONS; COMPUTER SOFTWARE PROGRAMMING AND DEVELOPMENT FOR ONLINE SOFTWARE APPLICATIONS, MOBILE PHONE APPLICATIONS AND WEBSITES, MOBILE COMPUTER AND TABLET APPLICATIONS AND WEBSITES, AND DESKTOP COMPUTER APPLICATIONS AND WEBSITES; COMPUTER SOFTWARE PROGRAMMING AND DEVELOPMENT FOR ONLINE SOFTWARE APPLICATIONS, MOBILE PHONE INTERNET BROWSERS, MOBILE COMPUTER AND TABLET INTERNET BROWSERS, AND DESKTOP COMPUTER INTERNET BROWSERS; COMPUTER GAME

CONSOLE INTERNET BROWSERS; SOFTWARE PROGRAMMING AND DEVELOPMENT OF CLOUD COMPUTING INFORMATION SYSTEMS, CUSTOM WEB APPLICATIONS, DIGITAL INFORMATION INTERFACES, INTERNET MARKETING APPLICATIONS, SOCIAL MEDIA PLATFORM APPLICATIONS, AND WEBSITE SEARCH ENGINE OPTIMIZATION; GRAPHIC DESIGN SERVICES; PROVIDING GRAPHIC AND MULTIMEDIA DESIGN SERVICES FOR THE PURPOSE OF PROMOTING THE GOODS AND SERVICES OF OTHERS; GRAPHIC DESIGN FOR DIGITAL INFORMATION INTERFACES, AND PRODUCT DEVELOPMENT OF OTHERS; GRAPHIC AND WEB DESIGN FOR CUSTOM WEB APPLICATIONS AND APPLICATIONS BUILT FOR SOCIAL MEDIA PLATFORMS; GRAPHIC DESIGN FOR PRINT, WEBSITES, MOBILE PHONE APPLICATIONS, MOBILE COMPUTER AND TABLET APPLICATIONS, AND DESKTOP APPLICATIONS; WEBSITE DESIGN AND DEVELOPMENT FOR OTHERS; WEBSITE DESIGN FOR MOBILE PHONE INTERNET BROWSERS, MOBILE COMPUTER AND TABLET INTERNET BROWSERS, AND DESKTOP INTERNET BROWSERS (U.S. CLS. 100 AND 101).

DANNEAN HETZEL, EXAMINING ATTORNEY

SN 85-178,541. LITER(HK) INDUSTRIAL CO., LIMITED, CENTRAL, HONG KONG, FILED 11-17-2010.



THE MARK CONSISTS OF A DESIGNED DEVICE WHICH INCLUDE TWO GEOMETRIC DRAWINGS.

#### CLASS 7—MACHINERY

FOR CAPPING MACHINES; ELECTRIC FOOD BLENDERS; ELECTRIC FOOD PROCESSORS; ELECTRIC FRUIT PRESSES FOR HOUSEHOLD USE; ELECTRIC WHISKS FOR HOUSEHOLD PURPOSES; JUICE EXTRACTORS; JUICE MACHINES; KITCHEN MACHINES, NAMELY, ELECTRIC STANDING MIXERS; MILLING MACHINES; MIXERS; MIXING MACHINES; POWER-OPERATED COFFEE GRINDERS (U.S. CLS. 13, 19, 21, 23, 31, 34 AND 35).

FIRST USE 1-1-2010; IN COMMERCE 1-1-2010.

#### CLASS 11—ENVIRONMENTAL CONTROL APPARATUS

FOR APPARATUS FOR THE EXCHANGE OF SUBSTANCES AND HEAT FOR USE IN THE PRODUCTION OF STEAM, FOR USE IN COOKING AND FOR USE IN REFRIGERATION; BAKING OVENS; BREAD BAKING MACHINES; ELECTRIC AUTOCLAVES; ELECTRIC COFFEE MACHINES; ELECTRIC YOGURT MAKERS; ICE CREAM MAKERS; ICE MACHINES AND APPARATUS; WATER FILTERING APPARATUS (U.S. CLS. 13, 21, 23, 31 AND 34).

FIRST USE 1-1-2010; IN COMMERCE 1-1-2010.  
GEORGE LORENZO, EXAMINING ATTORNEY

SN 85-178,532. LITER(HK) INDUSTRIAL CO., LIMITED, CENTRAL, HONG KONG, FILED 11-17-2010.

**MIXTEC**

THE MARK CONSISTS OF STYLIZED WORD "MIXTEC".

#### CLASS 7—MACHINERY

FOR CAPPING MACHINES; ELECTRIC FOOD BLENDERS; ELECTRIC FOOD PROCESSORS; ELECTRIC FRUIT PRESSES FOR HOUSEHOLD USE; ELECTRIC WHISKS FOR HOUSEHOLD PURPOSES; JUICE EXTRACTORS; JUICE MACHINES; KITCHEN MACHINES, NAMELY, ELECTRIC STANDING MIXERS; MILLING MACHINES; MIXERS; MIXING MACHINES; POWER-OPERATED COFFEE GRINDERS (U.S. CLS. 13, 19, 21, 23, 31, 34 AND 35).

FIRST USE 1-1-2010; IN COMMERCE 1-1-2010.

#### CLASS 11—ENVIRONMENTAL CONTROL APPARATUS

FOR APPARATUS FOR THE EXCHANGE OF SUBSTANCES AND HEAT FOR USE IN THE PRODUCTION OF STEAM, FOR USE IN COOKING AND FOR USE IN REFRIGERATION; BAKING OVENS; BREAD BAKING MACHINES; ELECTRIC AUTOCLAVES; ELECTRIC COFFEE MACHINES; ELECTRIC YOGURT MAKERS; ICE CREAM MAKERS; ICE MACHINES AND APPARATUS; WATER FILTERING APPARATUS (U.S. CLS. 13, 21, 23, 31 AND 34).

FIRST USE 1-1-2010; IN COMMERCE 1-1-2010.  
GEORGE LORENZO, EXAMINING ATTORNEY

SN 85-178,566. CORDO INNOVATIONS, LLC, NEW YORK, NY, FILED 11-17-2010.

**UGETPAID**

THE MARK CONSISTS OF STANDARD CHARACTERS WITHOUT CLAIM TO ANY PARTICULAR FONT, STYLE, SIZE, OR COLOR.

#### CLASS 9—ELECTRICAL AND SCIENTIFIC APPARATUS

FOR DOWNLOADABLE SOFTWARE IN THE NATURE OF A MOBILE APPLICATION FOR USE TO TRACK INFORMATION REGARDING CONSUMER TRENDS (U.S. CLS. 21, 23, 26, 36 AND 38).

**CLASS 35—ADVERTISING AND BUSINESS**

FOR PREPARATION OF REPORTS RELATING TO MARKET STUDIES AND CONSUMER PURCHASE TRENDS; MARKET RESEARCH CONSULTATION; MARKET STUDY AND ANALYSIS OF MARKET STUDIES (U.S. CLS. 100, 101 AND 102).

JOHN GARTNER, EXAMINING ATTORNEY

SN 85-178,610. SMITH & NEPHEW, INC., MEMPHIS, TN. FILED 11-17-2010.

**INVENTURES**

THE MARK CONSISTS OF STANDARD CHARACTERS WITHOUT CLAIM TO ANY PARTICULAR FONT, STYLE, SIZE, OR COLOR.

**CLASS 42—SCIENTIFIC AND COMPUTER SERVICES**

FOR RESEARCH AND DEVELOPMENT OF NEW PRODUCTS AND TECHNOLOGY IN THE FIELD OF SURGICAL AND MEDICAL APPARATUS AND INSTRUMENTS; CONSULTANCY SERVICES RELATING TO RESEARCH INTO THE DEVELOPMENT OF SURGICAL AND MEDICAL APPARATUS AND INSTRUMENTS (U.S. CLS. 100 AND 101).

**CLASS 44—MEDICAL, BEAUTY AND AGRICULTURAL SERVICES**

FOR ADVISORY SERVICES RELATING TO SURGICAL AND MEDICAL APPARATUS AND INSTRUMENTS (U.S. CLS. 100 AND 101).

ARETHA SOMERVILLE, EXAMINING ATTORNEY

SN 85-178,732. PLANET SMOOTHIE, LLC, ATLANTA, GA. FILED 11-17-2010.

**INVEST IN YOURSELF**

THE MARK CONSISTS OF STANDARD CHARACTERS WITHOUT CLAIM TO ANY PARTICULAR FONT, STYLE, SIZE, OR COLOR.

**CLASS 35—ADVERTISING AND BUSINESS**

FOR RETAIL STORE SERVICES FEATURING FROZEN DRINKS CONTAINING COLD FRUIT AND OTHER NATURAL INGREDIENTS, SPORTS DRINKS, SNACK FOODS, SANDWICHES, VITAMINS, HERBS, T-SHIRTS, POLO SHIRTS, HATS AND CUPS; ON-LINE RETAIL STORE SERVICES FEATURING VITAMINS, HERBS, T-SHIRTS, POLO SHIRTS, HATS AND CUPS (U.S. CLS. 100, 101 AND 102).

**CLASS 44—MEDICAL, BEAUTY AND AGRICULTURAL SERVICES**

FOR COUNSELING SERVICES IN THE FIELDS OF HEALTH, NUTRITION AND LIFESTYLE WELLNESS (U.S. CLS. 100 AND 101).

ZACHARY BELLO, EXAMINING ATTORNEY

SN 85-178,747. CRISMONA QUALITY FOODS, INC., WEST NEW JERSEY, NJ. FILED 11-17-2010.



THE MARK CONSISTS OF THE DRAWING OF THE HEAD OF A HUMAN LIKE CREATURE WITH POINTED EARS, CROWNED WITH LAURELS, TWO CLUSTERS OF GRAPES HANGING FROM ITS MOUTH; AND, TWO GRAPE LEAVES FLANK THE HEAD. BELOW THE DRAWING IS THE STYLIZED WORDING "SOTOLONGO".

THE WORDING "SOTOLONGO" HAS NO MEANING IN A FOREIGN LANGUAGE.

**CLASS 29—MEATS AND PROCESSED FOODS**

FOR EDIBLE OILS (U.S. CL. 46).  
FIRST USE 7-17-2007; IN COMMERCE 7-17-2007.

**CLASS 30—STAPLE FOODS**

FOR VINEGARS (U.S. CL. 46).  
FIRST USE 7-17-2007; IN COMMERCE 7-17-2007.  
FRANK LATTUCA, EXAMINING ATTORNEY

SN 85-178,906. LAHR, LLC, DOYLESTOWN, PA. FILED 11-17-2010.

**LAHR**

THE MARK CONSISTS OF STANDARD CHARACTERS WITHOUT CLAIM TO ANY PARTICULAR FONT, STYLE, SIZE, OR COLOR.

SEC. 2(F).

**CLASS 35—ADVERTISING AND BUSINESS**

FOR BUSINESS CONSULTATION SERVICES (U.S. CLS. 100, 101 AND 102).  
FIRST USE 5-31-2004; IN COMMERCE 5-31-2004.

**CLASS 36—INSURANCE AND FINANCIAL**

FOR FINANCIAL PLANNING AND INVESTMENT ADVISORY SERVICES; FINANCIAL SERVICES, NAMELY, WEALTH MANAGEMENT SERVICES (U.S. CLS. 100, 101 AND 102).

FIRST USE 5-31-2004; IN COMMERCE 5-31-2004.  
PRISCILLA MILTON, EXAMINING ATTORNEY

SN 85-178,945. PORTEC, INC., CANON CITY, CO. FILED 11-17-2010.

## IT'S YOUR TURN

THE MARK CONSISTS OF STANDARD CHARACTERS WITHOUT CLAIM TO ANY PARTICULAR FONT, STYLE, SIZE, OR COLOR.

### CLASS 7—MACHINERY

FOR BELT CONVEYORS; BELTS FOR CONVEYORS; CHAIN CONVEYORS; CONVEYOR BELTS; CONVEYOR LINES; CONVEYORS; ROLLER CONVEYORS; STAGED AND SEGMENTED CONVEYORS; WINDING MACHINES, PACKAGING MACHINES, CONVEYING MACHINES, PARTICULARLY CONVEYOR BELTS, ROLLER CONVEYORS AND CARRIER ROLLERS FOR WEB MATERIALS (U.S. CLS. 13, 19, 21, 23, 31, 34 AND 35).

FIRST USE 3-0-2009; IN COMMERCE 3-0-2009.

### CLASS 37—CONSTRUCTION AND REPAIR

FOR REPAIR OR MAINTENANCE OF CONVEYORS (U.S. CLS. 100, 103 AND 106).

FIRST USE 3-0-2009; IN COMMERCE 3-0-2009.  
ROBIN CHOSID, EXAMINING ATTORNEY

SN 85-178,995. ALISSA FINERMAN, SANTA MONICA, CA. FILED 11-17-2010.

## LIVING IN YOUR TOP 1%

THE MARK CONSISTS OF STANDARD CHARACTERS WITHOUT CLAIM TO ANY PARTICULAR FONT, STYLE, SIZE, OR COLOR.

### CLASS 41—EDUCATION AND ENTERTAINMENT

FOR CONDUCTING WORKSHOPS AND SEMINARS IN PERSONAL GROWTH, PROFESSIONAL GROWTH, SPIRITUALITY, AND SELF-HELP; EDUCATIONAL AND ENTERTAINMENT SERVICES, NAMELY, PROVIDING MOTIVATIONAL SPEAKING SERVICES IN THE FIELD OF PERSONAL GROWTH, PROFESSIONAL GROWTH, SPIRITUALITY, AND SELF-HELP; INTERACTIVE ONLINE WEB JOURNALS FEATURING BLOGS, NON-DOWNLOADABLE VIDEOS, AND INFORMATION IN THE FIELD OF PERSONAL GROWTH, PROFESSIONAL GROWTH, SPIRITUALITY, AND SELF-HELP; LIFE COACHING SERVICES IN THE FIELD OF PERSONAL GROWTH, PROFESSIONAL GROWTH, SPIRITUALITY, AND SELF-HELP (U.S. CLS. 100, 101 AND 107).

FIRST USE 11-16-2010; IN COMMERCE 11-16-2010.

### CLASS 45—PERSONAL AND LEGAL SERVICES

FOR PERSONAL GROWTH AND MOTIVATION CONSULTING SERVICES; PROVIDING ON-LINE INFORMATION IN THE FIELD OF SPIRITUALITY, SELF-HELP, AND PERSONAL EMPOWERMENT SUBJECT MATTERS (U.S. CLS. 100 AND 101).

FIRST USE 11-16-2010; IN COMMERCE 11-16-2010.  
BRENDAN REGAN, EXAMINING ATTORNEY

SN 85-179,136. MAID GREEN LLC, HARVEST, AL. FILED 11-17-2010.

## CLEAN IS TAKING ON A WHOLE NEW GREENING.

THE MARK CONSISTS OF STANDARD CHARACTERS WITHOUT CLAIM TO ANY PARTICULAR FONT, STYLE, SIZE, OR COLOR.

### CLASS 3—COSMETICS AND CLEANING PREPARATIONS

FOR ALL-PURPOSE CLEANERS; DISH DETERGENTS; GLASS CLEANERS; LAUNDRY DETERGENT; METAL POLISHING AND CLEANING PREPARATIONS; TOILET BOWL DETERGENTS (U.S. CLS. 1, 4, 6, 50, 51 AND 52).

### CLASS 37—CONSTRUCTION AND REPAIR

FOR CLEANING OF BUILDINGS (U.S. CLS. 100, 103 AND 106).

ERNEST SHOSHO, EXAMINING ATTORNEY

SN 85-179,173. PHASE 4 FILMS (USA), LLC, TORONTO, ONTARIO, CANADA, FILED 11-17-2010.

## WARRIOR LEGENDS

THE MARK CONSISTS OF STANDARD CHARACTERS WITHOUT CLAIM TO ANY PARTICULAR FONT, STYLE, SIZE, OR COLOR.

### CLASS 9—ELECTRICAL AND SCIENTIFIC APPARATUS

FOR CINEMATOGRAPHIC FILMS FEATURING LIVE ACTION AND ANIMATED CONTENT; DOWNLOADABLE FILMS AND MOVIES FEATURING LIVE ACTION AND ANIMATED CONTENT PROVIDED VIA A VIDEO-ON-DEMAND SERVICE; DOWNLOADABLE FILMS AND TELEVISION PROGRAMS FEATURING LIVE ACTION AND ANIMATED CONTENT PROVIDED VIA A VIDEO-ON-DEMAND SERVICE; MOTION PICTURE FILMS AND FILMS FOR TELEVISION FEATURING CHILDREN'S ENTERTAINMENT; MOTION PICTURE FILMS FEATURING CHILDREN'S ENTERTAINMENT (U.S. CLS. 21, 23, 26, 36 AND 38).

**CLASS 41—EDUCATION AND ENTERTAINMENT**

FOR DISTRIBUTION OF MOTION PICTURE FILMS; ENTERTAINMENT SERVICES, NAMELY, DISPLAYING A SERIES OF FILMS; FILM DISTRIBUTION; MEDIA PRODUCTION SERVICES, NAMELY, VIDEO AND FILM PRODUCTION; PRODUCTION AND DISTRIBUTION OF MONOSCOPIC AND STEREOSCOPIC, ELECTRONIC, DIGITAL VIDEO AND FILM; PROVISION OF INFORMATION RELATING TO DISTRIBUTION OF TELEVISION SHOWS, MOTION PICTURE FILM AND RADIO SHOWS; PROVISION OF INFORMATION RELATING TO TELEVISION, MOTION PICTURE FILM, AUDIO AND RADIO PRODUCTION; PROVISION OF NON-DOWNLOADABLE FILMS AND MOVIES VIA A VIDEO-ON-DEMAND SERVICE; PROVISION OF NON-DOWNLOADABLE FILMS AND TELEVISION PROGRAMMES VIA A VIDEO-ON-DEMAND SERVICE; RENTAL AND COMPUTERIZED ON-LINE RENTAL SERVICES FEATURING INTERACTIVE SOFTWARE AND HARDWARE HOME ENTERTAINMENT AND CONSUMER ELECTRONICS IN THE NATURE OF MOTION PICTURES, FILMS, MOVIES, PRERECORDED DIGITAL VERSATILE DISCS (OR DVDS), PRERECORDED VIDEOTAPE CASSETTES, AUDIO, AUDIO RECORDINGS IN A VARIETY OF GENRES (U.S. CLS. 100, 101 AND 107).

CAROLINE WOOD, EXAMINING ATTORNEY

---

SN 85-179,183. COMPONENTS SPECIALTIES, INC., AMITYVILLE, NY. FILED 11-17-2010.

**ONSIP**

THE MARK CONSISTS OF STANDARD CHARACTERS WITHOUT CLAIM TO ANY PARTICULAR FONT, STYLE, SIZE, OR COLOR.

**CLASS 9—ELECTRICAL AND SCIENTIFIC APPARATUS**

FOR CLOSED CIRCUIT TV SYSTEMS FOR SECURITY AND SURVEILLANCE, NAMELY, CAMERAS, SWITCHERS, MONITORS, MICROPHONES, AND RECORDERS; IP (INTERNET PROTOCOL) CAMERAS; IP (INTERNET PROTOCOL) SPEED DOME CAMERAS; WIRELESS COMMUNICATION DEVICES FOR TRANSMITTING IMAGES TAKEN BY A CAMERA (U.S. CLS. 21, 23, 26, 36 AND 38).

**CLASS 38—COMMUNICATION**

FOR TRANSMISSION OF SOUND, VIDEO AND INFORMATION FROM WEB CAMS, VIDEO CAMERAS OR MOBILE PHONES, ALL FEATURING LIVE OR RECORDED MATERIALS (U.S. CLS. 100, 101 AND 104).

**CLASS 45—PERSONAL AND LEGAL SERVICES**

FOR HOME SECURITY MONITORING USING WIRELESS AND WIRED SENSORS FOR GLASS BREAKAGE, MOTION DETECTORS, CAMERAS, POOL ALARMS, WATER ALARMS AND SHUTOFF VALVES, GATE, DOOR AND WINDOW CONTACT SENSORS, SEVERE WEATHER ALARMS (U.S. CLS. 100 AND 101).

CAROLINE WOOD, EXAMINING ATTORNEY

SN 85-179,211. ALISSA FINERMAN, SANTA MONICA, CA. FILED 11-17-2010.

**TOP 1%**

THE MARK CONSISTS OF STANDARD CHARACTERS WITHOUT CLAIM TO ANY PARTICULAR FONT, STYLE, SIZE, OR COLOR.

**CLASS 41—EDUCATION AND ENTERTAINMENT**

FOR CONDUCTING WORKSHOPS AND SEMINARS IN PERSONAL GROWTH, PROFESSIONAL GROWTH, SPIRITUALITY, AND SELF-HELP; EDUCATIONAL AND ENTERTAINMENT SERVICES, NAMELY, PROVIDING MOTIVATIONAL SPEAKING SERVICES IN THE FIELD OF PERSONAL GROWTH, PROFESSIONAL GROWTH, SPIRITUALITY, AND SELF-HELP; INTERACTIVE ONLINE WEB JOURNALS FEATURING BLOGS, NON-DOWNLOADABLE VIDEOS, AND INFORMATION IN THE FIELD OF PERSONAL GROWTH, PROFESSIONAL GROWTH, SPIRITUALITY, AND SELF-HELP; LIFE COACHING SERVICES IN THE FIELD OF PERSONAL GROWTH, PROFESSIONAL GROWTH, SPIRITUALITY, AND SELF-HELP (U.S. CLS. 100, 101 AND 107).

**CLASS 45—PERSONAL AND LEGAL SERVICES**

FOR PERSONAL GROWTH AND MOTIVATION CONSULTING SERVICES; PROVIDING ON-LINE INFORMATION IN THE FIELD OF SPIRITUALITY, SELF-HELP, AND PERSONAL EMPOWERMENT SUBJECT MATTERS (U.S. CLS. 100 AND 101).

BRENDAN REGAN, EXAMINING ATTORNEY

---

SN 85-179,224. ALISSA FINERMAN, SANTA MONICA, CA. FILED 11-17-2010.

**TOP 1%ER**

THE MARK CONSISTS OF STANDARD CHARACTERS WITHOUT CLAIM TO ANY PARTICULAR FONT, STYLE, SIZE, OR COLOR.

**CLASS 41—EDUCATION AND ENTERTAINMENT**

FOR CONDUCTING WORKSHOPS AND SEMINARS IN PERSONAL GROWTH, PROFESSIONAL GROWTH, SPIRITUALITY, AND SELF-HELP; EDUCATIONAL AND ENTERTAINMENT SERVICES, NAMELY, PROVIDING MOTIVATIONAL SPEAKING SERVICES IN THE FIELD OF PERSONAL GROWTH, PROFESSIONAL GROWTH, SPIRITUALITY, AND SELF-HELP; INTERACTIVE ONLINE WEB JOURNALS FEATURING BLOGS, NON-DOWNLOADABLE VIDEOS, AND INFORMATION IN THE FIELD OF PERSONAL GROWTH, PROFESSIONAL GROWTH, SPIRITUALITY, AND SELF-HELP; LIFE COACHING SERVICES IN THE FIELD OF PERSONAL GROWTH, PROFESSIONAL GROWTH, SPIRITUALITY, AND SELF-HELP (U.S. CLS. 100, 101 AND 107).



**CLASS 45—PERSONAL AND LEGAL SERVICES**

FOR PERSONAL GROWTH AND MOTIVATION CONSULTING SERVICES; PROVIDING ON-LINE INFORMATION IN THE FIELD OF SPIRITUALITY, SELF-HELP, AND PERSONAL EMPOWERMENT SUBJECT MATTERS (U.S. CLS. 100 AND 101).

BRENDAN REGAN, EXAMINING ATTORNEY

**CLASS 42—SCIENTIFIC AND COMPUTER SERVICES**

FOR PROVIDING TEMPORARY USE OF ON-LINE NON-DOWNLOADABLE SOFTWARE TO STORE, MANAGE, TRACK, ANALYZE, AND REPORT DATA IN THE FIELD OF MARKETING, PROMOTION, SALES, CUSTOMER INFORMATION, CUSTOMER RELATIONSHIP MANAGEMENT, SALES SUPPORT AND EMPLOYEE EFFICIENCY; PROVIDING TEMPORARY USE OF ON-LINE NON-DOWNLOADABLE SOFTWARE TO FACILITATE COMMUNICATING AMONG PEER PROFESSIONALS IN THE ADVERTISING, MARKETING AND BUSINESS SERVICES FIELDS, AND FOR CUSTOMIZING COMPUTER APPLICATION USER INTERFACES; COMPUTER SERVICES, NAMELY, DESIGNING, DEVELOPING, AND MAINTAINING COMPUTER SOFTWARE APPLICATIONS FOR OTHERS AND CONSULTING SERVICES RELATED THERETO; PROVIDING TEMPORARY USE OF ONLINE NON-DOWNLOADABLE COMPUTER SOFTWARE APPLICATION DEVELOPMENT TOOLS AND PROGRAMMING LANGUAGE FOR USE IN DEVELOPING, ANALYZING, CODING, CHECKING, AND CONTROLLING OTHER COMPUTER SOFTWARE; PROVIDING TEMPORARY USE OF ONLINE NON-DOWNLOADABLE COMPUTER SOFTWARE THAT IMPLEMENTS A PROCEDURAL AND OBJECT-ORIENTED PROGRAMMING LANGUAGE; ONLINE HOSTED COMPUTER SERVICES, NAMELY, DESIGNING, DEVELOPING, CUSTOMIZING, AND MAINTAINING COMPUTER SOFTWARE APPLICATIONS FOR OTHERS; AND CONSULTING SERVICES RELATED THERETO (U.S. CLS. 100 AND 101).

ESTHER A. BORSUK, EXAMINING ATTORNEY

SN 85-179,331. SALESFORCE.COM, INC., SAN FRANCISCO, CA. FILED 11-17-2010.

**FORCE2**

THE MARK CONSISTS OF STANDARD CHARACTERS WITHOUT CLAIM TO ANY PARTICULAR FONT, STYLE, SIZE, OR COLOR.

**CLASS 9—ELECTRICAL AND SCIENTIFIC APPARATUS**

FOR DOWNLOADABLE COMPUTER SOFTWARE FOR USE IN DEVELOPING AND CUSTOMIZING COMPUTER SOFTWARE APPLICATIONS AND COMPUTER SOFTWARE APPLICATION USER INTERFACES; COMPUTER SOFTWARE FOR STORING, MANAGING, TRACKING, ANALYZING, AND REPORTING DATA IN THE FIELD OF MARKETING, PROMOTION, SALES, CUSTOMER INFORMATION, CUSTOMER RELATIONSHIP MANAGEMENT, SALES SUPPORT, AND EMPLOYEE EFFICIENCY; COMPUTER SOFTWARE TO FACILITATE COMMUNICATING AMONG PEER PROFESSIONALS IN THE ADVERTISING, MARKETING, AND BUSINESS SERVICES FIELDS, AND FOR CUSTOMIZING COMPUTER APPLICATION USER INTERFACES (U.S. CLS. 21, 23, 26, 36 AND 38).

**CLASS 35—ADVERTISING AND BUSINESS**

FOR BUSINESS MANAGEMENT SERVICES, NAMELY, PROVIDING INFORMATION, DATA ASSET, AND IDENTITY MANAGEMENT SERVICES; COMPILATION AND MANAGEMENT OF COMPUTERIZED DATABASES AND CONSULTING SERVICES RELATED THERETO; BUSINESS MANAGEMENT SERVICES, NAMELY, PROVIDING CUSTOMER RELATIONSHIP MANAGEMENT SERVICES AND SALES SUPPORT MANAGEMENT SERVICES; BUSINESS MANAGEMENT CONSULTING SERVICES RELATING TO CUSTOMER RELATIONSHIP MANAGEMENT, SALES SUPPORT MANAGEMENT, AND MARKETING AUTOMATION; PROVIDING A WEBSITE FEATURING INFORMATION IN THE FIELDS OF ADVERTISING, MARKETING AND BUSINESS MANAGEMENT; CONSULTING AND ADVISORY SERVICES IN THE FIELDS OF ADVERTISING, MARKETING AND BUSINESS MANAGEMENT; OPERATING ONLINE MARKETPLACES FOR BUYING AND SELLING, SHARING, AND OFFERING FOR FREE COMPUTER SOFTWARE AND ON-DEMAND APPLICATIONS (U.S. CLS. 100, 101 AND 102).

SN 85-179,349. GABI CONCEPTS LTD., TORONTO, ONTARIO, CANADA, FILED 11-17-2010.

**ESPRESSO**

THE MARK CONSISTS OF STANDARD CHARACTERS WITHOUT CLAIM TO ANY PARTICULAR FONT, STYLE, SIZE, OR COLOR.

**CLASS 18—LEATHER GOODS**

FOR NON-INSULATED GROCERY TOTE BAGS MADE OF TEXTILES; HANDBAGS; LUGGAGE, BACKPACKS, TOTE BAGS, WALLETS, COSMETIC BAGS AND TOILETRY CASES SOLD EMPTY FOR MEN AND WOMEN (U.S. CLS. 1, 2, 3, 22 AND 41).

**CLASS 21—HOUSEWARES AND GLASS**

FOR THERMAL INSULATED LUNCH BAGS; NON-METAL WATER BOTTLES SOLD EMPTY; THERMAL INSULATED GROCERY TOTE BAGS, INSULATED CONTAINERS FOR FOOD FOR DOMESTIC USE (U.S. CLS. 2, 13, 23, 29, 30, 33, 40 AND 50).

DOMINIC J. FERRAIUOLO, EXAMINING ATTORNEY

SN 85-179,442. AG HOLDING S.A., LUXEMBOURG, LUXEMBOURG, FILED 11-17-2010.

SN 85-179,491. KIDEALY, LLC, DENVER, CO. FILED 11-17-2010.

## ANGELO GALASSO

THE MARK CONSISTS OF STANDARD CHARACTERS WITHOUT CLAIM TO ANY PARTICULAR FONT, STYLE, SIZE, OR COLOR.

OWNER OF ERP N CMNTY TM OFC REG. NO. 008996639, DATED 9-20-2010, EXPIRES 9-20-2020.

THE NAME(S), PORTRAIT(S), AND/OR SIGNATURE(S) SHOWN IN THE MARK IDENTIFIES "ANGELO GALASSO", WHOSE CONSENT(S) TO REGISTER IS MADE OF RECORD.

### CLASS 3—COSMETICS AND CLEANING PREPARATIONS

FOR SOAPS; PERFUMERY; COSMETICS, HAIR LOTIONS; DENTIFRICES; AFTER SHAVE LOTIONS; ANTIPERSPIRANTS; ALL PURPOSE CLEANING PREPARATIONS; COSMETIC CREAMS; EAU DE COLOGNE; ESSENTIAL OILS; SHAMPOOS; SHAVING PREPARATIONS; SKIN AND HAIR CARE PREPARATIONS; NON-MEDICATED TOILETRIES (U.S. CLS. 1, 4, 6, 50, 51 AND 52).

### CLASS 14—JEWELRY

FOR PRECIOUS METALS AND THEIR ALLOYS; JEWELRY, PRECIOUS STONES, HOROLOGICAL AND CHROMOMETRIC INSTRUMENTS (U.S. CLS. 2, 27, 28 AND 50).

### CLASS 18—LEATHER GOODS

FOR LEATHER AND IMITATIONS OF LEATHER AND GOODS MADE FROM THESE MATERIALS, NAMELY, LUGGAGE, TRUNKS AND TRAVELING BAGS; UMBRELLAS; LEATHER BAGS; BRIEFCASES; KEY CASES; WALLETS AND PURSES (U.S. CLS. 1, 2, 3, 22 AND 41).

### CLASS 25—CLOTHING

FOR CLOTHING, NAMELY, PANTS, SHORTS, SWEATPANTS, OVERALLS, SHIRTS, T-SHIRTS, SWEATSHIRTS, DRESSES, SKIRTS, BLOUSES, JACKETS, VESTS, COATS, RAINWEAR, LINGERIE, SLEEPWEAR, UNDERWEAR, LOUNGEWEAR, BEACHWEAR, SWIMWEAR, INFANTWEAR, GLOVES, SOCKS, HOSIERY, BELTS, SCARVES, HATS, TIES, FOOTWEAR, HEADWEAR (U.S. CLS. 22 AND 39).

### CLASS 35—ADVERTISING AND BUSINESS

FOR RETAIL SERVICES IN THE FIELDS OF PERFUMERY, TOILETRIES AND COSMETICS, LEATHER GOODS, IMITATION LEATHER GOODS, TRAVEL GOODS, CLOTHING AND ACCESSORIES, FOOTWEAR AND HEADGEAR (U.S. CLS. 100, 101 AND 102).  
JOHN HWANG, EXAMINING ATTORNEY

# KIDEALY

THE MARK CONSISTS OF STANDARD CHARACTERS WITHOUT CLAIM TO ANY PARTICULAR FONT, STYLE, SIZE, OR COLOR.

### CLASS 35—ADVERTISING AND BUSINESS

FOR PROMOTING THE GOODS AND SERVICES OF OTHERS BY MEANS OF OPERATING AN ON-LINE SHOPPING MALL WITH LINKS TO THE RETAIL WEB SITES OF OTHERS (U.S. CLS. 100, 101 AND 102).

FIRST USE 11-3-2010; IN COMMERCE 11-3-2010.

### CLASS 41—EDUCATION AND ENTERTAINMENT

FOR ON-LINE JOURNALS, NAMELY BLOGS FEATURING PARENTING TIPS AND IDEAS FOR OR ABOUT FAMILY ACTIVITIES (U.S. CLS. 100, 101 AND 107).

FIRST USE 11-15-2010; IN COMMERCE 11-15-2010.

CAROL SPILS, EXAMINING ATTORNEY

SN 85-179,504. THE CLOROX COMPANY, OAKLAND, CA. FILED 11-17-2010.



OWNER OF U.S. REG. NOS. 3,687,365, 3,690,559 AND 3,736,912.

THE COLOR(S) YELLOW, ORANGE, GREEN, BLACK IS/ARE CLAIMED AS A FEATURE OF THE MARK.

THE MARK CONSISTS OF A FLOWER WITH YELLOW PETALS WITH ORANGE SHADES APPEARING TOWARD THE CENTER OF THE FLOWER, GREEN CENTER, AND BLACK SHADOW SURROUNDING THE GREEN CENTER.

### CLASS 24—FABRICS

FOR BATH TOWELS; BEACH TOWELS; DISH CLOTHS; HAND TOWELS; KITCHEN TOWELS; MATRESS COVERS; PILLOW CASES (U.S. CLS. 42 AND 50).

### CLASS 27—FLOOR COVERINGS

FOR BATH MATS (U.S. CLS. 19, 20, 37, 42 AND 50).  
AMY ALFIERI, EXAMINING ATTORNEY

SN 85-179,528. KIM, HYE R, DBA POLYMAESTRO, CARLSBAD, CA. FILED 11-17-2010.

PolyMaestro

THE MARK CONSISTS OF STANDARD CHARACTERS WITHOUT CLAIM TO ANY PARTICULAR FONT, STYLE, SIZE, OR COLOR.

#### CLASS 1—CHEMICALS

FOR CHEMICALLY MODIFIED PLASTIC AND CLAY COMPOSITION FOR USE IN THE MANUFACTURE OF PLASTICS; CHEMICALS AND UNPROCESSED PLASTICS, NAMELY, POLYMERS FOR ELECTRONIC MATERIALS; CHEMICALS FOR RUBBER AND PLASTICS PROCESSING APPLICATIONS; CHEMICALS, NAMELY, UV LIGHT STABILIZERS FOR USE IN ENGINEERING PLASTICS; KIT COMPRISING POLYMER BASED COMPOSITION, TAPE AND PLASTIC COATING FOR FORMING HANDLES MOLDABLE TO THE INDIVIDUAL'S HAND; PLASTIC ADHESIVES; PLASTIC MOLDING COMPOUNDS FOR USE IN PLASTIC EXTRUSION OPERATIONS; PLASTIC MOLDING COMPOUNDS FOR USE IN THE MANUFACTURE OF MOLDED PLASTIC ARTICLES; PLASTIC MOLDING COMPOUNDS FOR USE IN THE MANUFACTURE OF PLASTIC SHEETS AND FILMS; PLASTICS IN UNPROCESSED FORM, IN POWDER, LIQUID OR PASTE FORM; POLYMER ALLOY COMPOSITIONS USED FOR MOLDING; POLYMER BASE COMPOSITIONS USED IN THE MANUFACTURE OF COMMERCIAL, INDUSTRIAL AND DOMESTIC GOODS; POLYMER BASE COMPOSITIONS USED IN THE MANUFACTURE OF GOODS, NAMELY, CLOTHING, EXERCISE APPAREL, COMPRESSION GARMENTS, HOME FURNISHING; POLYMER COMPOSITIONS USED IN THE MANUFACTURE OF COMMERCIAL AND INDUSTRIAL GOODS; POLYMER RESINS USED IN THE MANUFACTURE OF RESIN OR FIBER COMPOSITES; POLYMERIZATION PLASTICS; POLYMERS AND POLYMERIC ADDITIVES FOR USE IN THE MANUFACTURE OF INDUSTRIAL PRODUCTS, CONSUMER AND HOUSEHOLD PRODUCTS, SEALANTS, AND AUTOMOTIVE FLUIDS; POLYMERS AND POLYMERIC ADDITIVES FOR USE IN THE MANUFACTURE OF PHARMACEUTICAL PREPARATIONS, MEDICAL DEVICES, PLASTICS, COSMETICS, PERSONAL CARE PRODUCTS, COATINGS, ADHESIVES, AND LUBRICANTS; POLYMERS AND POLYMERIC ADDITIVES FOR USE IN THE MANUFACTURE OF PHARMACEUTICAL PREPARATIONS, PLASTICS, COSMETICS, PERSONAL CARE PRODUCTS, COATINGS, ADHESIVES, AND LUBRICANTS; SYNTHETIC RESINS FOR USE IN THE MANUFACTURE OF PLASTIC MOLDING COMPOUNDS; THERMOSETTING PLASTIC REFRACTORY MATERIALS; UNPROCESSED PLASTIC IN THE FORM OF POWDER OR GRANULES; UNPROCESSED PLASTIC MATERIALS IN POWDER, LIQUID OR PASTE FORM; UNPROCESSED PLASTICS; UNPROCESSED PLASTICS FOR INDUSTRIAL USE; UNPROCESSED PLASTICS IN ALL FORMS (U.S. CLS. 1, 5, 6, 10, 26 AND 46).

#### CLASS 17—RUBBER GOODS

FOR ADHESIVE PLASTIC FILM FOR INDUSTRIAL AND COMMERCIAL USE; EXTRUDED IMPACT RESISTANT POLYMER SHEETS FOR USE IN MANUFACTURING A WIDE VARIETY OF PLASTIC PRODUCTS; FILMS AND SHEETS MADE FROM POLYMERS FOR USE IN THE MANUFACTURE OF CIRCUIT BOARDS; NANOCOMPOSITE POLYMER COMPOUNDS IN PELLET FORM FOR USE IN FURTHER MANUFACTURE; PLASTIC FILM FOR COMMERCIAL AND INDUSTRIAL USE; PLASTIC FILM FOR USE IN LAMINATING PAPER; PLASTIC IN BARS, BLOCKS, PELLETS, RODS, SHEETS AND TUBES FOR GENERAL INDUSTRIAL USE; PLASTIC IN EXTRUDED FORM FOR GENERAL INDUSTRIAL USE; PLASTIC IN POWDERED FORM; PLASTIC MATERIAL IN EXTRUDED FORM FOR USE IN PRODUCTION (U.S. CLS. 1, 5, 12, 13, 35 AND 50).  
CHRISIE B. KING, EXAMINING ATTORNEY

SN 85-179,596. BRAZENN ENTERPRISES INC, EASTON, PA. FILED 11-18-2010.

fotag

THE MARK CONSISTS OF STANDARD CHARACTERS WITHOUT CLAIM TO ANY PARTICULAR FONT, STYLE, SIZE, OR COLOR.

#### CLASS 6—METAL GOODS

FOR KEY FOBS OF COMMON METAL; KEYRINGS OF COMMON METAL; METAL HARDWARE, NAMELY, CARABINERS OF METAL; METAL KEY CHAINS; METAL KEY HOLDERS; METAL KEY RINGS; METAL RINGS AND CHAINS FOR KEYS (U.S. CLS. 2, 12, 13, 14, 23, 25 AND 50).

#### CLASS 20—FURNITURE AND ARTICLES NOT OTHERWISE CLASSIFIED

FOR PICTURE AND PHOTOGRAPH FRAMES (U.S. CLS. 2, 13, 22, 25, 32 AND 50).  
MAYUR VAGHANI, EXAMINING ATTORNEY

SN 85-179,597. WOODS, NANCY T., NEW YORK, NY. FILED 11-18-2010.

icanapps

THE MARK CONSISTS OF STANDARD CHARACTERS WITHOUT CLAIM TO ANY PARTICULAR FONT, STYLE, SIZE, OR COLOR.

**CLASS 9—ELECTRICAL AND SCIENTIFIC APPARATUS**

FOR CHILDREN'S EDUCATIONAL MUSIC CDS AND DVDS; CHILDREN'S EDUCATIONAL SOFTWARE; COMPUTER GAME CARTRIDGES; COMPUTER GAME CARTRIDGES AND DISCS; COMPUTER GAME PROGRAMS, CARTRIDGES, AND CASSETTES; COMPUTER PROGRAMS FOR PRE-RECORDED GAMES (U.S. CLS. 21, 23, 26, 36 AND 38).

**CLASS 16—PAPER GOODS AND PRINTED MATTER**

FOR EDUCATIONAL AND LEARNING PUBLICATIONS, NAMELY, BOOKLETS AND FLASH CARDS ON A VARIETY OF EDUCATIONAL DISCIPLINES IN PRE-SCHOOL THROUGH EIGHTH GRADE; EDUCATIONAL PUBLICATIONS, NAMELY, EDUCATIONAL LEARNING CARDS, FLASH CARDS, ACTIVITY CARDS, WORKBOOKS, TEXTBOOKS, ACTIVITY BOOKS, STORY BOOKS, PUZZLE BOOKS, PRINTED PUZZLES, TEACHER GUIDES, MANUALS, POSTERS AND EDUCATIONAL BOOKLETS IN THE FIELD OF SPECIAL EDUCATION, READING, DYSLEXIA (U.S. CLS. 2, 5, 22, 23, 29, 37, 38 AND 50).

VIVIAN MICZNIK FIRST, EXAMINING ATTORNEY

SN 85-179,670. BAYER AG, LEVERKUSEN, FED REP GERMANY, FILED 11-18-2010.



THE MARK CONSISTS OF THE WORDS "LIVING FIT" EXCLAMATION MARK "!" AND THE WORDS "A JOINT EFFORT" STYLIZED.

**CLASS 16—PAPER GOODS AND PRINTED MATTER**

FOR PRINTED EDUCATIONAL MATERIALS, NAMELY, MAGAZINES, NEWSLETTERS, MANUALS, BOOKS, INSTRUCTIONAL AND TEACHING MATERIALS ABOUT HEMOPHILIA FOR DISTRIBUTION TO HEMOPHILIA PATIENTS AND TO PERSONS TREATING HEMOPHILIA (U.S. CLS. 2, 5, 22, 23, 29, 37, 38 AND 50).

**CLASS 41—EDUCATION AND ENTERTAINMENT**

FOR EDUCATIONAL SERVICES, NAMELY, CONDUCTING WORKSHOPS, CONFERENCES, CLASSES, SEMINARS, IN THE FIELD OF HEMOPHILIA (U.S. CLS. 100, 101 AND 107).

**CLASS 44—MEDICAL, BEAUTY AND AGRICULTURAL SERVICES**

FOR PROVIDING HEALTH INFORMATION ABOUT HEMOPHILIA FOR HEMOPHILIA PATIENTS AND FOR PERSONS TREATING HEMOPHILIA; MEDICAL SERVICES FOR HEMOPHILIA PATIENTS (U.S. CLS. 100 AND 101).

HOWARD B. LEVINE, EXAMINING ATTORNEY

SN 85-179,713. MEERS ADVERTISING, INC., KANSAS CITY, MO. FILED 11-18-2010.

# TriggerSend

THE MARK CONSISTS OF STANDARD CHARACTERS WITHOUT CLAIM TO ANY PARTICULAR FONT, STYLE, SIZE, OR COLOR.

**CLASS 35—ADVERTISING AND BUSINESS**

FOR MAIL SORTING, HANDLING AND RECEIVING (U.S. CLS. 100, 101 AND 102).

**CLASS 38—COMMUNICATION**

FOR E-MAIL DATA SERVICES (U.S. CLS. 100, 101 AND 104).

DAVID HOFFMAN, EXAMINING ATTORNEY

SN 85-180,083. BRAVO WELLNESS, LLC, AVON, OH. FILED 11-18-2010.

THE COLOR(S) ORANGE, PURPLE, BLUE, LIGHT GREEN, GREEN, AND RED IS/ARE CLAIMED AS A FEATURE OF THE MARK.

THE MARK CONSISTS OF THE STYLIZED WORD CHEERS, CONSISTING OF AN ORANGE CAPITALIZED "C"; A PURPLE CAPITALIZED "H"; A BLUE FIRST LOWERCASE "E"; A LIGHT GREEN SECOND LOWERCASE "E"; A GREEN CAPITALIZED "R"; AND A RED CAPITALIZED "S".

**CLASS 35—ADVERTISING AND BUSINESS**

FOR BUSINESS SERVICES, NAMELY, CONDUCTING EMPLOYEE WELLNESS-BASED INCENTIVE AWARD PROGRAMS FOR CORPORATE CLIENTS TO PROMOTE HEALTHY LIFESTYLE OF EMPLOYEES AND LOWER HEALTH CARE COSTS OF CORPORATIONS; CUSTOMIZED DESIGN SERVICES, NAMELY, DESIGNING OF EMPLOYEE WELLNESS-BASED INCENTIVE AWARD PROGRAMS FOR CORPORATE CLIENTS TO LOWER HEALTH CARE COSTS OF CORPORATIONS FOR BUSINESS (U.S. CLS. 100, 101 AND 102).

FIRST USE 9-21-2010; IN COMMERCE 9-21-2010.

**CLASS 44—MEDICAL, BEAUTY AND AGRICULTURAL SERVICES**

FOR CUSTOMIZED DESIGN SERVICES, NAMELY, DESIGNING OF EMPLOYEE WELLNESS-BASED INCENTIVE AWARD PROGRAMS FOR CORPORATE CLIENTS TO PROMOTE HEALTHY LIFESTYLES OF EMPLOYEES FOR THE PURPOSE OF ENABLING EMPLOYEES TO MAINTAIN A HEALTHY LIFESTYLE (U.S. CLS. 100 AND 101).

FIRST USE 9-21-2010; IN COMMERCE 9-21-2010.  
MIDGE BUTLER, EXAMINING ATTORNEY

SN 85-180,096. MAINSTREET CAPITAL PARTNERS, LLC, CICERO, IN. FILED 11-18-2010.



THE COLOR(S) YELLOW, ORANGE, GREEN, AND BLUE IS/ARE CLAIMED AS A FEATURE OF THE MARK.

THE MARK CONSISTS OF A STYLIZED SPARK, CONSISTING OF TWO OPPOSING GREEN V-SHAPED ELEMENTS WITH DARK GREEN AT THEIR POINTS AND WITH SIDES OF TWO DIFFERING LIGHTER SHADES OF GREEN, AND OF TWO OPPOSING AND DIFFERENTLY COLORED V-SHAPED ELEMENTS, ONE WITH DARK BLUE AT ITS POINT AND WITH SIDES OF TWO DIFFERING LIGHTER SHADES OF BLUE, AND THE OTHER OPPOSING V-SHAPED ELEMENT WITH DARK ORANGE AT ITS POINT AND WITH ONE SIDE A LIGHTER SHADE OF ORANGE AND WITH THE OTHER SIDE YELLOW.

SN 85-180,092. HOBBY LOBBY STORES, INC., OKLAHOMA CITY, OK. FILED 11-18-2010.

**BRIGHT IDEAS**

THE MARK CONSISTS OF STANDARD CHARACTERS WITHOUT CLAIM TO ANY PARTICULAR FONT, STYLE, SIZE, OR COLOR.

**CLASS 6—METAL GOODS**

FOR TINS OF METAL (U.S. CLS. 2, 12, 13, 14, 23, 25 AND 50).

**CLASS 11—ENVIRONMENTAL CONTROL APPARATUS**

FOR LIGHTED PARTY-THEMED DECORATIONS, ELECTRIC LIGHT DECORATIVE STRINGS (U.S. CLS. 13, 21, 23, 31 AND 34).

**CLASS 21—HOUSEWARES AND GLASS**

FOR BASKETS OF WICKER; CANDLE HOLDERS; DECORATIVE PLATES; DISPOSABLE DINNERWARE, NAMELY, PLATES; TABLE PLACE CARD HOLDERS NOT OF PRECIOUS METAL (U.S. CLS. 2, 13, 23, 29, 30, 33, 40 AND 50).

**CLASS 26—FANCY GOODS**

FOR ARTIFICIAL GARLANDS (U.S. CLS. 37, 39, 40, 42 AND 50).  
DEIRDRE ROBERTSON, EXAMINING ATTORNEY

**CLASS 36—INSURANCE AND FINANCIAL**

FOR CAPITAL INVESTMENT SERVICES; FINANCIAL INVESTMENT IN THE FIELD OF REAL ESTATE (U.S. CLS. 100, 101 AND 102).

FIRST USE 1-1-2010; IN COMMERCE 1-1-2010.

**CLASS 37—CONSTRUCTION AND REPAIR**

FOR HOUSING SERVICES, NAMELY, DEVELOPMENT OF REAL PROPERTY, NAMELY, REPAIR, IMPROVEMENT, AND NEW CONSTRUCTION (U.S. CLS. 100, 103 AND 106).

FIRST USE 1-1-2010; IN COMMERCE 1-1-2010.

DEZMONA MIZELLE, EXAMINING ATTORNEY

SN 85-180,128. DIAMOND FOODS, INC., STOCKTON, CA. FILED 11-18-2010.



OWNER OF U.S. REG. NOS. 724,880, 1,801,304 AND OTHERS.

NO CLAIM IS MADE TO THE EXCLUSIVE RIGHT TO USE "OF CALIFORNIA", APART FROM THE MARK AS SHOWN.

THE COLOR(S) RED, GOLD AND WHITE IS/ARE CLAIMED AS A FEATURE OF THE MARK.

THE MARK CONSISTS OF THE TERMS "DIAMOND" AND "OF CALIFORNIA" ON TWO LINES IN WHITE AGAINST A RED DIAMOND BACKGROUND WITH A GOLD BORDER AND WHITE RAYS EMANATING FROM ABOVE THE TERM "DIAMOND". THE TERMS "OF CALIFORNIA" APPEARS IN SMALLER TYPE BELOW "DIAMOND".

**CLASS 29—MEATS AND PROCESSED FOODS**

FOR SHELLED NUTS, PROCESSED NUTS; EDIBLE OILS (U.S. CL. 46).  
FIRST USE 7-0-1991; IN COMMERCE 7-0-1991.

**CLASS 31—NATURAL AGRICULTURAL PRODUCTS**

FOR UNSHELLED NUTS AND UNPROCESSED NUTS (U.S. CLS. 1 AND 46).  
FIRST USE 9-11-1991; IN COMMERCE 9-11-1991.

**CLASS 35—ADVERTISING AND BUSINESS**

FOR ONLINE RETAIL STORE SERVICES FEATURING NUTS AND NUT PRODUCTS (U.S. CLS. 100, 101 AND 102).  
FIRST USE 7-0-2007; IN COMMERCE 7-0-2007.  
CURTIS FRENCH, EXAMINING ATTORNEY

SN 85-180,156. MAINSTREET CAPITAL PARTNERS, LLC, CICERO, IN. FILED 11-18-2010.

**INVESTING MORE THAN CAPITAL**

THE MARK CONSISTS OF STANDARD CHARACTERS WITHOUT CLAIM TO ANY PARTICULAR FONT, STYLE, SIZE, OR COLOR.

**CLASS 36—INSURANCE AND FINANCIAL**

FOR CAPITAL INVESTMENT SERVICES; FINANCIAL INVESTMENT IN THE FIELD OF REAL ESTATE (U.S. CLS. 100, 101 AND 102).  
FIRST USE 1-1-2010; IN COMMERCE 1-1-2010.

**CLASS 37—CONSTRUCTION AND REPAIR**

FOR HOUSING SERVICES, NAMELY, DEVELOPMENT OF REAL PROPERTY, NAMELY, REPAIR, IMPROVEMENT, AND NEW CONSTRUCTION (U.S. CLS. 100, 103 AND 106).  
FIRST USE 1-1-2010; IN COMMERCE 1-1-2010.  
DEZMONA MIZELLE, EXAMINING ATTORNEY

SN 85-180,239. WINFIELD SOLUTIONS, LLC, SHOREVIEW, MN. FILED 11-18-2010.

**CATAPULT**

THE MARK CONSISTS OF STANDARD CHARACTERS WITHOUT CLAIM TO ANY PARTICULAR FONT, STYLE, SIZE, OR COLOR.

**CLASS 1—CHEMICALS**

FOR ADJUVANT FOR USE WITH AGRICULTURAL CHEMICALS (U.S. CLS. 1, 5, 6, 10, 26 AND 46).

**CLASS 5—PHARMACEUTICALS**

FOR PESTICIDES FOR AGRICULTURAL USE (U.S. CLS. 6, 18, 44, 46, 51 AND 52).  
LINDA MICKLEBURGH, EXAMINING ATTORNEY

SN 85-180,311. RATIONAL INTELLECTUAL HOLDINGS LIMITED, DOUGLAS, ISLE OF MAN, FILED 11-18-2010.



NO CLAIM IS MADE TO THE EXCLUSIVE RIGHT TO USE "HOME GAMES", APART FROM THE MARK AS SHOWN.

THE MARK CONSISTS OF THE OUTLINE OF A HOUSE WITHIN WHICH IS CENTERED A SPADE DESIGN CONTAINING A FIVE-POINTED STAR. TO THE RIGHT OF THIS DESIGN ARE THE TERMS "HOME" AND "GAMES" IN A STYLIZED FONT, ARRANGED VERTICALLY.

**CLASS 9—ELECTRICAL AND SCIENTIFIC APPARATUS**

FOR DOWNLOADABLE COMPUTER CARD GAME SOFTWARE AND COMPUTER GAMBLING GAME SOFTWARE (U.S. CLS. 21, 23, 26, 36 AND 38).

**CLASS 41—EDUCATION AND ENTERTAINMENT**

FOR ON-LINE ENTERTAINMENT IN THE NATURE OF CARD GAMES AND GAMBLING TOURNAMENTS AND COMPETITIONS; CASINO ON-LINE SERVICES FEATURING INTERACTIVE MULTI-PLAYER CARD GAMES AND GAMBLING; ORGANIZATION OF AND ADMINISTRATION OF CARD GAMES AND CONTESTS, INTERACTIVE ON-LINE CARD GAMES AND GAMBLING CONTESTS; PROVIDING NEWSLETTERS IN THE FIELD OF ON-LINE AND OFF-LINE GAMBLING VIA EMAIL (U.S. CLS. 100, 101 AND 107).  
MARGERY A. TIERNEY, EXAMINING ATTORNEY

SN 85-180,619. ENTRACITY, INC., CARLSBAD, CA. FILED 11-18-2010.

**LinkTagstic**

THE MARK CONSISTS OF STANDARD CHARACTERS WITHOUT CLAIM TO ANY PARTICULAR FONT, STYLE, SIZE, OR COLOR.

**CLASS 9—ELECTRICAL AND SCIENTIFIC APPARATUS**

FOR COMPUTER HARDWARE AND COMPUTER SOFTWARE PROGRAMS FOR THE INTEGRATION OF TEXT, AUDIO, GRAPHICS, STILL IMAGES AND MOVING PICTURES INTO AN INTERACTIVE DELIVERY FOR MULTIMEDIA APPLICATIONS; COMPUTER SEARCH ENGINE SOFTWARE; COMPUTER SOFTWARE FOR ACCESSING INFORMATION DIRECTORIES THAT MAY BE DOWNLOADED FROM THE GLOBAL COMPUTER NETWORK; COMPUTER SOFTWARE FOR APPLICATION AND DATABASE INTEGRATION; COMPUTER SOFTWARE FOR COMMUNICATING WITH USERS OF HAND-HELD COMPUTERS; COMPUTER SOFTWARE FOR CONTROLLING AND MANAGING ACCESS SERVER APPLICATIONS; COMPUTER SOFTWARE FOR CREATING SEARCHABLE DATABASES OF INFORMATION AND DATA; COMPUTER SOFTWARE FOR PROVIDING AN ON-LINE DATABASE IN THE FIELD OF TRANSACTION PROCESSING TO UPLOAD TRANSACTIONAL DATA, PROVIDE STATISTICAL ANALYSIS, AND PRODUCE NOTIFICATIONS AND REPORTS; COMPUTER SOFTWARE FOR THE COLLECTION, EDITING, ORGANIZING, MODIFYING, BOOK MARKING, TRANSMISSION, STORAGE AND SHARING OF DATA AND INFORMATION; COMPUTER SOFTWARE THAT ASSISTS COMPUTERS IN DEPLOYING PARALLEL APPLICATIONS AND PERFORMING PARALLEL COMPUTATIONS; COMPUTER SOFTWARE THAT PROVIDES REAL-TIME, INTEGRATED BUSINESS MANAGEMENT INTELLIGENCE BY COMBINING INFORMATION FROM VARIOUS DATABASES AND PRESENTING IT IN AN EASY-TO-UNDERSTAND USER INTERFACE; COMPUTER SOFTWARE THAT PROVIDES WEB-BASED ACCESS TO APPLICATIONS AND SERVICES THROUGH A WEB OPERATING SYSTEM OR PORTAL INTERFACE; COMPUTER SOFTWARE TO ENHANCE THE AUDIO-VISUAL CAPABILITIES OF MULTIMEDIA APPLICATIONS, NAMELY, FOR THE INTEGRATION OF TEXT, AUDIO, GRAPHICS, STILL IMAGES AND MOVING PICTURES; ENTERPRISE SOFTWARE IN THE NATURE OF A DATABASE FOR NON-TRANSACTIONAL DATA AND A SEARCH ENGINE FOR DATABASE CONTENT (U.S. CLS. 21, 23, 26, 36 AND 38).

**CLASS 35—ADVERTISING AND BUSINESS**

FOR ADVERTISING AND MARKETING SERVICES PROVIDED BY MEANS OF INDIRECT METHODS OF MARKETING COMMUNICATIONS, NAMELY, SOCIAL MEDIA, SEARCH ENGINE MARKETING, INQUIRY MARKETING, INTERNET MARKETING, MOBILE MARKETING, BLOGGING AND OTHER FORMS OF PASSIVE, SHARABLE OR VIRAL COMMUNICATIONS CHANNELS; ADVERTISING THE SERVICES OF OTHERS VIA WEB PAGES OPTIMIZED FOR ONLINE SEARCH ENGINES; ONLINE MEDIA MONITORING SERVICES USING COMPUTER SOFTWARE TO AUTOMATICALLY MONITOR INTERNET WEBSITES AND ONLINE PUBLICATIONS FOR CUSTOMER-SPECIFIED TOPICS AND TO CAPTURE RELEVANT CONTENT ON THOSE TOPICS, AND PROVIDING DOCUMENTATION AND ANALYSIS OF THAT ONLINE CONTENT TO OTHERS FOR BUSINESS PURPOSES; PROMOTING THE GOODS AND SERVICES OF OTHERS THROUGH SEARCH ENGINE REFERRAL TRAFFIC ANALYSIS AND REPORTING (U.S. CLS. 100, 101 AND 102).

**CLASS 42—SCIENTIFIC AND COMPUTER SERVICES**

FOR COMPUTER SERVICES, NAMELY, PROVIDING SEARCH ENGINES FOR OBTAINING DATA FROM JOURNALS AND OTHER PUBLICATIONS ON A GLOBAL COMPUTER NETWORK; COMPUTER SERVICES, NAMELY, PROVIDING SEARCH ENGINES FOR OBTAINING DATA ON A GLOBAL COMPUTER NETWORK; COMPUTER SERVICES, NAMELY, SEARCH ENGINE OPTIMIZATION; CONSULTATION SERVICES IN THE FIELD OF SEARCH ENGINE OPTIMIZATION; DEVELOPMENT, MAINTENANCE AND UPDATING OF A TELECOMMUNICATION NETWORK SEARCH ENGINE; PROVIDING A WEBSITE FEATURING A MEDIA AGGREGATOR AND SEARCH ENGINE FOR INTERNET CONTENT; PROVIDING CUSTOMIZED ON-LINE WEB PAGES FEATURING USER-DEFINED INFORMATION, WHICH INCLUDES SEARCH ENGINES AND ON-LINE WEB LINKS TO OTHER WEB SITES; PROVISION OF INTERNET SEARCH ENGINES; PROVISION OF SEARCH ENGINES FOR THE INTERNET (U.S. CLS. 100 AND 101).

GINA HAYES, EXAMINING ATTORNEY

SN 85-181,059. SOUL CENTERED, INC., OJAI, CA. AND DIANE SILVESTER, OJAI, CA. FILED 11-19-2010.

# Soul Centered

THE MARK CONSISTS OF STANDARD CHARACTERS WITHOUT CLAIM TO ANY PARTICULAR FONT, STYLE, SIZE, OR COLOR.

**CLASS 35—ADVERTISING AND BUSINESS**

FOR RETAIL STORE AND ON-LINE RETAIL STORE SERVICES FEATURING BOOKS AND MATERIALS FOR METAPHYSICAL EDUCATION (U.S. CLS. 100, 101 AND 102).

FIRST USE 4-9-2004; IN COMMERCE 5-18-2005.

**CLASS 41—EDUCATION AND ENTERTAINMENT**

FOR ENTERTAINMENT AND EDUCATIONAL SERVICES, NAMELY, THE PRESENTATION OF SEMINARS, LECTURES, WORKSHOPS AND PANEL DISCUSSIONS, AND ONGOING TELEVISION AND RADIO TALK SHOWS ALL IN THE FIELD OF PUBLIC INTEREST CONCERNING METAPHYSICS AND PSYCHIC PHENOMENON (U.S. CLS. 100, 101 AND 107).

FIRST USE 4-9-2004; IN COMMERCE 5-18-2005.

CHRISTINA SOBRAL, EXAMINING ATTORNEY

SN 85-181,237. BALASUBRAMANYAM, KOVILAKUNTLA, SAN FRANCISCO, CA. FILED 11-19-2010.

# FXCENTRAL

THE MARK CONSISTS OF STANDARD CHARACTERS WITHOUT CLAIM TO ANY PARTICULAR FONT, STYLE, SIZE, OR COLOR.

**CLASS 35—ADVERTISING AND BUSINESS**

FOR ADVERTISING AND BUSINESS MANAGEMENT CONSULTANCY; BUSINESS OPERATION, BUSINESS ADMINISTRATION AND OFFICE FUNCTIONS (U.S. CLS. 100, 101 AND 102).

**CLASS 36—INSURANCE AND FINANCIAL**

FOR FINANCIAL PLANNING AND INVESTMENT ADVISORY SERVICES; STOCK BROKING SERVICES (U.S. CLS. 100, 101 AND 102).

MATTHEW EINSTEIN, EXAMINING ATTORNEY

SN 85-181,247. MADE HER THINK, INC., NEW YORK, NY. FILED 11-19-2010.

MADE HER THINK

THE MARK CONSISTS OF STANDARD CHARACTERS WITHOUT CLAIM TO ANY PARTICULAR FONT, STYLE, SIZE, OR COLOR.

**CLASS 14—JEWELRY**

FOR JEWELRY (U.S. CLS. 2, 27, 28 AND 50). FIRST USE 5-0-2004; IN COMMERCE 5-0-2004.

**CLASS 18—LEATHER GOODS**

FOR HANDBAGS (U.S. CLS. 1, 2, 3, 22 AND 41). FIRST USE 9-0-2009; IN COMMERCE 9-0-2009. ODESSA BIBBINS, EXAMINING ATTORNEY

SN 85-181,671. HAVEN HALL, L.P., TUSTIN, CA. FILED 11-19-2010.

DEFINE YOUR TIME

THE MARK CONSISTS OF STANDARD CHARACTERS WITHOUT CLAIM TO ANY PARTICULAR FONT, STYLE, SIZE, OR COLOR.

**CLASS 6—METAL GOODS**

FOR METAL KEY CHAINS; METAL RINGS AND CHAINS FOR KEYS (U.S. CLS. 2, 12, 13, 14, 23, 25 AND 50).

**CLASS 14—JEWELRY**

FOR CUFFLINKS; DESK CLOCKS; EARRINGS; KEY CHAINS AS JEWELLERY; KEY CHAINS OF PRECIOUS METAL; TIMEPIECES; WALL CLOCKS (U.S. CLS. 2, 27, 28 AND 50).

**CLASS 16—PAPER GOODS AND PRINTED MATTER**

FOR WRITING INSTRUMENTS (U.S. CLS. 2, 5, 22, 23, 29, 37, 38 AND 50).

**CLASS 18—LEATHER GOODS**

FOR FASHION HANDBAGS; IMITATION LEATHER KEY CHAINS; LEATHER KEY CHAINS; WALLETS (U.S. CLS. 1, 2, 3, 22 AND 41).

**CLASS 20—FURNITURE AND ARTICLES NOT OTHERWISE CLASSIFIED**

FOR NON-METAL AND NON-LEATHER KEY CHAINS (U.S. CLS. 2, 13, 22, 25, 32 AND 50).

**CLASS 26—FANCY GOODS**

FOR HAIR CLIPS (U.S. CLS. 37, 39, 40, 42 AND 50). JANICE KIM, EXAMINING ATTORNEY

SN 85-182,522. PATTI, THOMAS J, PITTSFIELD, MA. AND PATTI, MARILYN HOLTZ, PITTSFIELD, MA. FILED 11-22-2010.

ARTGUARD

THE MARK CONSISTS OF STANDARD CHARACTERS WITHOUT CLAIM TO ANY PARTICULAR FONT, STYLE, SIZE, OR COLOR.

**CLASS 9—ELECTRICAL AND SCIENTIFIC APPARATUS**

FOR ANTI-GLARE GLASSES; BULLET-PROOF GLASS; BULLET-RESISTANT GLASS (U.S. CLS. 21, 23, 26, 36 AND 38).

**CLASS 19—NON-METALLIC BUILDING MATERIALS**

FOR BUILDING GLASS; COLORED SHEET GLASS; COMMON SHEET GLASS; DECORATIVE GLASS; GLASS FOR BUILDING; LAMINATED FLAT GLASS; MODIFIED SHEET GLASS; SAFETY GLASS FOR BUILDING PURPOSES; STAINED GLASS WINDOWS (U.S. CLS. 1, 12, 33 AND 50).

**CLASS 21—HOUSEWARES AND GLASS**

FOR COLORED SHEET GLASS; COMMON SHEET GLASS; DECORATIVE GLASS; LAMINATED FLAT GLASS; LUMINOUS GLASS; WORKS OF ART MADE OF GLASS (U.S. CLS. 2, 13, 23, 29, 30, 33, 40 AND 50). THEODORE MCBRIDE, EXAMINING ATTORNEY

SN 85-183,347. FRISCH, HILARY, PEEKSKILL, NY. FILED 11-23-2010.

ABC MIND

THE MARK CONSISTS OF STANDARD CHARACTERS WITHOUT CLAIM TO ANY PARTICULAR FONT, STYLE, SIZE, OR COLOR.



NO CLAIM IS MADE TO THE EXCLUSIVE RIGHT TO USE "MIND", APART FROM THE MARK AS SHOWN.

SN 85-184,093. LUCASFILM LTD, SAN FRANCISCO, CA. FILED 11-23-2010.

#### **CLASS 41—EDUCATION AND ENTERTAINMENT**

FOR EDUCATIONAL SERVICES, NAMELY, SEMINARS, WORKSHOPS, CONFERENCES, SPEECHES, PRESENTATIONS AND PROGRAMS, ALL IN THE FIELDS OF PSYCHOLOGICAL COACHING, WELLNESS THERAPY, MEDITATION AND SELF-ENHANCEMENT SYSTEMS FOR IMPROVING PERSONAL, TEAM, ORGANIZATIONAL AND BUSINESS SKILLS, ABILITIES AND PERFORMANCE, AND THE DISTRIBUTION OF ELECTRONIC AND PRINT TRAINING MATERIALS IN THE FORM OF TEACHING GUIDES, BROCHURES, BOOKS, BOOKLETS AND NEWSLETTERS IN CONNECTION THEREWITH; TRAINING SERVICES IN THE FIELD OF MEDITATION AND PSYCHOLOGICAL SKILL BUILDING; PERSONAL COACHING SERVICES IN THE FIELDS OF WELLNESS, PSYCHOLOGICAL ENHANCEMENT, AND MEDITATION; MEDITATION TRAINING CONSULTING (U.S. CLS. 100, 101 AND 107).  
FIRST USE 9-30-2009; IN COMMERCE 9-30-2009.

#### **CLASS 44—MEDICAL, BEAUTY AND AGRICULTURAL SERVICES**

FOR CONSULTING SERVICES IN THE FIELDS OF WELLNESS, PSYCHOLOGICAL ENHANCEMENT, PSYCHOLOGICAL SKILL BUILDING, AND MEDITATION (U.S. CLS. 100 AND 101).  
FIRST USE 9-30-2009; IN COMMERCE 9-30-2009.  
BRIAN PINO, EXAMINING ATTORNEY

SN 85-183,862. HOBBY LOBBY STORES, INC., OKLAHOMA CITY, OK. FILED 11-23-2010.

## **LITTLE WISHES**

THE MARK CONSISTS OF STANDARD CHARACTERS WITHOUT CLAIM TO ANY PARTICULAR FONT, STYLE, SIZE, OR COLOR.

#### **CLASS 20—FURNITURE AND ARTICLES NOT OTHERWISE CLASSIFIED**

FOR PICTURE AND PHOTOGRAPH FRAMES (U.S. CLS. 2, 13, 22, 25, 32 AND 50).

#### **CLASS 21—HOUSEWARES AND GLASS**

FOR CUPS; PLATES (U.S. CLS. 2, 13, 23, 29, 30, 33, 40 AND 50).

#### **CLASS 24—FABRICS**

FOR CHILDREN'S BLANKETS (U.S. CLS. 42 AND 50).

#### **CLASS 25—CLOTHING**

FOR CLOTH BIBS; INFANT AND TODDLER ONE PIECE CLOTHING (U.S. CLS. 22 AND 39).

#### **CLASS 28—TOYS AND SPORTING GOODS**

FOR CHRISTMAS TREE ORNAMENTS AND DECORATIONS (U.S. CLS. 22, 23, 38 AND 50).  
DEIRDRE ROBERTSON, EXAMINING ATTORNEY

## **INDIANA JONES AND THE STAFF OF KINGS**

THE MARK CONSISTS OF STANDARD CHARACTERS WITHOUT CLAIM TO ANY PARTICULAR FONT, STYLE, SIZE, OR COLOR.

OWNER OF U.S. REG. NOS. 1,341,020, 1,918,634 AND OTHERS.

#### **CLASS 9—ELECTRICAL AND SCIENTIFIC APPARATUS**

FOR INTERACTIVE ENTERTAINMENT SOFTWARE AND ACCOMPANYING INSTRUCTION MANUALS SOLD AS A UNIT, NAMELY, COMPUTER GAME SOFTWARE AND MANUALS SOLD AS A UNIT, VIDEO GAME SOFTWARE AND MANUALS SOLD AS A UNIT, INTERACTIVE VIDEO GAME PROGRAMS, INTERACTIVE COMPUTER GAME PROGRAMS, PRE-RECORDED VIDEO TAPES FEATURING GAMES, FILMS, AND MUSIC; AND PRE-RECORDED CD-ROMS AND DVDS FEATURING GAMES, FILMS, AND MUSIC, COMPUTER GAME SOFTWARE, VIDEO GAME SOFTWARE, DOWNLOADABLE COMPUTER GAME SOFTWARE, DOWNLOADABLE INTERACTIVE ENTERTAINMENT SOFTWARE FOR PLAYING COMPUTER GAMES, AND DOWNLOADABLE INTERACTIVE ENTERTAINMENT SOFTWARE FOR PLAYING COMPUTER GAMES AND VIDEO GAMES (U.S. CLS. 21, 23, 26, 36 AND 38).  
FIRST USE 6-9-2009; IN COMMERCE 6-9-2009.

#### **CLASS 41—EDUCATION AND ENTERTAINMENT**

FOR ENTERTAINMENT SERVICES, NAMELY, PROVIDING INFORMATION RELATING TO INTERACTIVE COMPUTER GAME SOFTWARE, INTERACTIVE VIDEO GAME SOFTWARE, INTERACTIVE COMPUTER GAMES AND INTERACTIVE VIDEO GAMES ALL VIA LOCAL AREA NETWORKS AND THE GLOBAL COMPUTER INFORMATION NETWORK; PROVIDING ON-LINE NEWS AND INFORMATION RELATING TO INTERACTIVE COMPUTER GAME SOFTWARE, INTERACTIVE VIDEO GAME SOFTWARE, INTERACTIVE COMPUTER GAMES AND INTERACTIVE VIDEO GAMES ALL RELATING TO SCIENCE FICTION; FAN CLUB SERVICES; ENTERTAINMENT SERVICES, NAMELY, PROVIDING ON-LINE COMPUTER GAMES AND PROVIDING ON-LINE COMPUTER VIDEO GAMES; PROVIDING COMPUTER AND VIDEO GAMES THAT MAY BE ACCESSED NETWORK WIDE BY NETWORK USERS; ENTERTAINMENT SERVICES, NAMELY, LIVE PERFORMANCES BY PERSONALITIES PORTRAYING FICTIONAL CHARACTERS; ENTERTAINMENT SERVICES, NAMELY, PROVIDING EDUCATIONAL SPEAKERS TO DISCUSS FICTIONAL CHARACTERS AND ENTERTAINMENT; ENTERTAINMENT, NAMELY, A CONTINUING VARIETY, NEWS, COMEDY AND SCIENCE FICTION SHOW TRANSMITTED OVER TELEVISION, SATELLITE, AUDIO AND VIDEO MEDIA (U.S. CLS. 100, 101 AND 107).

FIRST USE 6-9-2009; IN COMMERCE 6-9-2009.  
CAROLYN CATALDO, EXAMINING ATTORNEY

SN 85-184,214. MEGATRAX PRODUCTION MUSIC, INC.,  
NORTH HOLLYWOOD, CA. FILED 11-23-2010.

**megatrax**  
The Sound of Entertainment

OWNER OF U.S. REG. NOS. 1,898,704, 2,866,607 AND  
3,145,436.

THE MARK CONSISTS OF THE STYLIZED MARK  
"MEGATRAX THE SOUND OF ENTERTAINMENT".

**CLASS 9—ELECTRICAL AND SCIENTIFIC  
APPARATUS**

FOR PRE-RECORDED COMPACT DISCS FEATURING  
MUSIC, AND CD-ROMS FEATURING MUSIC AND  
CATALOGS OF MUSIC (U.S. CLS. 21, 23, 26, 36 AND 38).

**CLASS 41—EDUCATION AND ENTERTAIN-  
MENT**

FOR MAINTAINING A LIBRARY OF RECORDED  
MUSIC FOR LICENSING PURPOSES; RECORD PRO-  
DUCTION SERVICES; MUSIC PUBLISHING SERVICES,  
PRODUCING AUDIO RECORDINGS OF MUSIC AND  
SOUND EFFECTS (U.S. CLS. 100, 101 AND 107).  
KHANH LE, EXAMINING ATTORNEY

**CLASS 42—SCIENTIFIC AND COMPUTER  
SERVICES**

FOR ANALYSIS OF OIL ANALYSIS OF OIL FIELDS;  
DATA AUTOMATION AND COLLECTION SERVICE  
USING PROPRIETARY SOFTWARE TO EVALUATE,  
ANALYZE AND COLLECT SERVICE DATA; ENGI-  
NEERING; EXPLORATION AND SEARCHING OF OIL  
AND GAS; OIL AND GAS WELL DRILLING SERVICES,  
NAMELY, PROVIDING MEASUREMENTS AND DOWN-  
HOLE TELEMETRY WHILE DRILLING; OIL PROS-  
PECTING, NAMELY, WELL LOGGING AND  
TESTING; OIL WELL TESTING; OIL-FIELD SURVEYS;  
PROVIDING TECHNOLOGY INFORMATION IN THE  
OIL AND GAS INDUSTRY; SURVEYING OF OIL BEDS  
AND FIELDS; WELL LOGGING FIELDS; DATA AUTO-  
MATION AND COLLECTION SERVICE USING PRO-  
PRIETARY SOFTWARE TO EVALUATE, ANALYZE  
AND COLLECT SERVICE DATA; ENGINEERING; EX-  
PLORATION AND SEARCHING OF OIL AND GAS; OIL  
AND GAS WELL DRILLING SERVICES, NAMELY,  
PROVIDING MEASUREMENTS AND DOWNHOLE  
TELEMETRY WHILE DRILLING; OIL PROSPECTING,  
NAMELY, WELL LOGGING AND TESTING; OIL WELL  
TESTING; OIL-FIELD SURVEYS; PROVIDING TECH-  
NOLOGY INFORMATION IN THE OIL AND GAS  
INDUSTRY; SURVEYING OF OIL BEDS AND FIELDS;  
WELL LOGGING (U.S. CLS. 100 AND 101).

FIRST USE 1-1-2010; IN COMMERCE 1-1-2010.  
KATINA MISTER, EXAMINING ATTORNEY

SN 85-187,063. JAMES P. OWEN, AUSTIN, TX. FILED 11-30-  
2010.

**KEEPER OF THE CODE**

THE MARK CONSISTS OF STANDARD CHARACTERS  
WITHOUT CLAIM TO ANY PARTICULAR FONT, STYLE,  
SIZE, OR COLOR.

**CLASS 25—CLOTHING**

FOR CLOTHING, NAMELY, SHIRTS, JACKETS,  
HATS, CAPS, VESTS, BLOUSES, AND BELTS (U.S. CLS.  
22 AND 39).

**CLASS 41—EDUCATION AND ENTERTAIN-  
MENT**

FOR EDUCATIONAL AND ENTERTAINMENT SER-  
VICES, NAMELY, PROVIDING MOTIVATIONAL  
SPEAKING SERVICES AND CLASSES, SEMINARS,  
WORKSHOPS AND PROGRAMS IN THE FIELDS OF  
LEADERSHIP, ETHICS, MOTIVATION, INSPIRATION,  
PERSEVERANCE, VALUES, AND PERSONAL GROWTH  
AND DEVELOPMENT; PROVIDING RECOGNITION  
AND INCENTIVES BY THE WAY OF AWARDS TO  
DEMONSTRATE EXCELLENCE IN THE FIELD OF  
LEADERSHIP, TO PROMOTE ETHICAL LEADERSHIP,  
AND TO REWARD PROGRAM PARTICIPANTS (U.S.  
CLS. 100, 101 AND 107).

GISELLE AGOSTO, EXAMINING ATTORNEY

SN 85-186,218. BAKER HUGHES INCORPORATED, HOUS-  
TON, TX. FILED 11-29-2010.

**AZITRAK**

THE MARK CONSISTS OF STANDARD CHARACTERS  
WITHOUT CLAIM TO ANY PARTICULAR FONT, STYLE,  
SIZE, OR COLOR.

**CLASS 37—CONSTRUCTION AND REPAIR**

FOR BORING OF WELLS; RENTAL OF OIL WELL  
DRILLING TOOLS (U.S. CLS. 100, 103 AND 106).  
FIRST USE 1-1-2010; IN COMMERCE 1-1-2010.

SN 85-187,077. JAMES P. OWEN, AUSTIN, TX. FILED 11-30-2010.

SN 85-191,770. NEXON CORPORATION, SEOUL, REPUBLIC OF KOREA, FILED 12-6-2010.

**LIVING COWBOY ETHICS**

THE MARK CONSISTS OF STANDARD CHARACTERS WITHOUT CLAIM TO ANY PARTICULAR FONT, STYLE, SIZE, OR COLOR.

**CLASS 21—HOUSEWARES AND GLASS**

FOR CUPS AND MUGS; INSULATING SLEEVE HOLDER FOR BEVERAGE CUPS; INSULATING SLEEVE HOLDER FOR BEVERAGE CANS (U.S. CLS. 2, 13, 23, 29, 30, 33, 40 AND 50).

**CLASS 25—CLOTHING**

FOR CLOTHING, NAMELY, SHIRTS, JACKETS, HATS, CAPS, VESTS, BLOUSES, AND BELTS (U.S. CLS. 22 AND 39).

GISELLE AGOSTO, EXAMINING ATTORNEY

SN 85-187,161. JAMES P. OWEN, AUSTIN, TX. FILED 11-30-2010.

**IF YOU CAN DREAM IT, YOU CAN DO IT**

THE MARK CONSISTS OF STANDARD CHARACTERS WITHOUT CLAIM TO ANY PARTICULAR FONT, STYLE, SIZE, OR COLOR.

**CLASS 25—CLOTHING**

FOR CLOTHING, NAMELY, SHIRTS, JACKETS, HATS, CAPS, VESTS, BLOUSES, AND BELTS (U.S. CLS. 22 AND 39).

**CLASS 41—EDUCATION AND ENTERTAINMENT**

FOR EDUCATIONAL AND ENTERTAINMENT SERVICES, NAMELY, PROVIDING MOTIVATIONAL SPEAKING SERVICES AND CLASSES, SEMINARS, WORKSHOPS AND PROGRAMS IN THE FIELDS OF LEADERSHIP, ETHICS, MOTIVATION, INSPIRATION, PERSEVERANCE, VALUES, AND PERSONAL GROWTH AND DEVELOPMENT; PROVIDING RECOGNITION AND INCENTIVES BY THE WAY OF AWARDS TO DEMONSTRATE EXCELLENCE IN THE FIELD OF LEADERSHIP, TO PROMOTE ETHICAL LEADERSHIP, AND TO REWARD PROGRAM PARTICIPANTS (U.S. CLS. 100, 101 AND 107).

GISELLE AGOSTO, EXAMINING ATTORNEY



THE MARK CONSISTS OF THE COINED SINGLE WORD "DINOSINGERS" IN STYLIZED CAPITAL LETTERS, WITH "DINO" CENTERED ABOVE "SINGERS"; THE SYMBOL FOR TWO SIXTEENTH NOTES PLACED ABOVE AND BETWEEN THE "N" AND "O" IN "DINO"; AND THE "S" IN "SINGERS", LARGER THAN THE OTHER LETTERS, REPRESENTING A CARICATURE OF A DINOSAUR FEATURING EYES, TWO TEETH AND A TONGUE.

**CLASS 9—ELECTRICAL AND SCIENTIFIC APPARATUS**

FOR ELECTRONIC DOWNLOADABLE GAME SOFTWARE FOR WIRELESS COMMUNICATION DEVICES, NAMELY, CELLULAR AND MOBILE TELEPHONES, AND HANDHELD ELECTRONIC DEVICES (U.S. CLS. 21, 23, 26, 36 AND 38).

**CLASS 28—TOYS AND SPORTING GOODS**

FOR TOYS, NAMELY, RUBBER CHARACTER TOYS, PLUSH TOYS AND HAND HELD UNITS FOR PLAYING VIDEO GAMES OTHER THAN THOSE ADAPTED FOR USE WITH AN EXTERNAL DISPLAY SCREEN OR MONITOR (U.S. CLS. 22, 23, 38 AND 50).

**CLASS 38—COMMUNICATION**

FOR MOBILE MEDIA SERVICES IN THE NATURE OF ELECTRONIC TRANSMISSION OF ENTERTAINMENT MEDIA CONTENT TO MOBILE TELEPHONES (U.S. CLS. 100, 101 AND 104).

**CLASS 41—EDUCATION AND ENTERTAINMENT**

FOR ENTERTAINMENT SERVICES, NAMELY, PRODUCTION OF ELECTRONIC GAME SOFTWARE FOR WIRELESS COMMUNICATION DEVICES, CELLULAR AND MOBILE TELEPHONES, AND HANDHELD ELECTRONIC DEVICES; ENTERTAINMENT SERVICES, NAMELY, PROVIDING ONLINE ELECTRONIC GAMES TO WIRELESS COMMUNICATION DEVICES, CELLULAR AND MOBILE TELEPHONES, AND HANDHELD ELECTRONIC DEVICES; ENTERTAINMENT SERVICES, NAMELY, PROVIDING ONLINE COMPUTER GAMES (U.S. CLS. 100, 101 AND 107).

ELI HELLMAN, EXAMINING ATTORNEY

SN 85-192,059. ENTERTAINMENT PUBLICATIONS LLC, TROY, MI. FILED 12-7-2010.

**SAVE MORE. DO MORE.**

THE MARK CONSISTS OF STANDARD CHARACTERS WITHOUT CLAIM TO ANY PARTICULAR FONT, STYLE, SIZE, OR COLOR.

**CLASS 9—ELECTRICAL AND SCIENTIFIC APPARATUS**

FOR DOWNLOADABLE SOFTWARE IN THE NATURE OF A MOBILE APPLICATION FOR MANAGEMENT AND RETRIEVAL OF MERCHANT LISTS AND MERCHANT INFORMATION INCLUDING DISCOUNT OFFERS AND ELECTRONIC CONSUMER COUPONS FOR IMMEDIATE OR FUTURE USE BY CONSUMERS (U.S. CLS. 21, 23, 26, 36 AND 38).

SN 85-192,414. PAPER MART, INC., EAST HANOVER, NJ. FILED 12-7-2010.

**CLASS 16—PAPER GOODS AND PRINTED MATTER**

FOR BOOKS, BOOKLETS, AND PRINTED COUPON AND DISCOUNT CARDS ALL WHICH ENTITLE THE HOLDER TO RECEIVE DISCOUNTS ON DINING, HOTEL ACCOMMODATIONS, CONSUMER MERCHANDISE, TRAVEL, MOVIES, SPORTS, THEATER, AND OTHER LEISURE ACTIVITIES SOLD SEPARATELY OR AS PART OF A UNIT (U.S. CLS. 2, 5, 22, 23, 29, 37, 38 AND 50).

FIRST USE 7-1-2010; IN COMMERCE 7-1-2010.

THE COLOR(S) MEDIUM GREEN, DARK GREEN, WARM RED IS/ARE CLAIMED AS A FEATURE OF THE MARK.

THE MARK CONSISTS OF INTERLOCKING LETTERS "PM" IN MEDIUM AND DARK GREEN SUPERIMPOSED OVER A STYLIZED GLOBE IN WARM RED, WITH THREE EVERGREEN TREES TO THE LOWER RIGHT IN SHADES OF GREEN.

**CLASS 35—ADVERTISING AND BUSINESS**

FOR ADVERTISING AND PROMOTIONAL SERVICES, NAMELY, PROMOTING THE GOODS AND SERVICES OF OTHERS THROUGH THE DISTRIBUTION OF COUPONS, AND DISCOUNT OFFERS WHICH ENTITLE THE HOLDER TO RECEIVE DISCOUNTS ON DINING, HOTEL ACCOMMODATIONS, CONSUMER MERCHANDISE, TRAVEL, MOVIES, SPORTS, THEATER AND OTHER LEISURE ACTIVITIES; PROVIDING ADVERTISING SERVICES THROUGH THE DISTRIBUTION OF ADVERTISEMENTS, COUPONS AND DISCOUNT OFFERS FOR DISPLAY ON INTERNET, NAMELY, IN WEBSITES, E-MAILS AND MULTIMEDIA MESSAGES; CONDUCTING AND ADMINISTERING AN ONLINE MEMBERSHIP PROGRAM ENTITLING THE PARTICIPANTS TO RECEIVE DISCOUNTS ON DINING, HOTEL ACCOMMODATIONS, CONSUMER MERCHANDISE, TRAVEL, MOVIES, SPORTS, THEATER AND OTHER LEISURE ACTIVITIES, AND PROVIDING IN CONNECTION THEREWITH AN ON-LINE DIRECTORY OF INFORMATION ABOUT THE DISCOUNT PROGRAM AND PARTICIPATING BUSINESSES (U.S. CLS. 100, 101 AND 102).

FIRST USE 7-1-2010; IN COMMERCE 7-1-2010.

**CLASS 16—PAPER GOODS AND PRINTED MATTER**

FOR PAPER GOODS, NAMELY, XEROGRAPHIC, DUPLICATING, OFFSET PRINTING, PRINTING, MIMEOGRAPH, VELLUM AND BRISTOL BOARD (U.S. CLS. 2, 5, 22, 23, 29, 37, 38 AND 50).

**CLASS 35—ADVERTISING AND BUSINESS**

FOR DISTRIBUTORSHIP SERVICES IN THE FIELD OF STATIONERY (U.S. CLS. 100, 101 AND 102).

**CLASS 40—MATERIAL TREATMENT**

FOR PRINTING SERVICES (U.S. CLS. 100, 103 AND 106).

JEFFREY LOOK, EXAMINING ATTORNEY

SN 85-193,865. AMERICAN AUTOMOBILE ASSOCIATION, INC., HEATHROW, FL. FILED 12-9-2010.

# KEYS2DRIVE

THE MARK CONSISTS OF STANDARD CHARACTERS WITHOUT CLAIM TO ANY PARTICULAR FONT, STYLE, SIZE, OR COLOR.

**CLASS 36—INSURANCE AND FINANCIAL**

FOR CHARITABLE FUNDRAISING SERVICES EFFECTED THROUGH A MEMBERSHIP PROGRAM WHICH ENTITLES THE PARTICIPANTS TO DISTRIBUTE COUPONS AND DISCOUNT OFFERS WHICH ALLOWS THE HOLDER TO RECEIVE DISCOUNTS ON DINING, HOTEL ACCOMMODATION, CONSUMER MERCHANDISE, TRAVEL, MOVIES, SPORTS, THEATER AND OTHER LEISURE ACTIVITIES (U.S. CLS. 100, 101 AND 102).

FIRST USE 7-1-2010; IN COMMERCE 7-1-2010.  
TEJBIR SINGH, EXAMINING ATTORNEY

**CLASS 36—INSURANCE AND FINANCIAL**

FOR PROVIDING INFORMATION TO TEEN DRIVERS IN THE FIELD OF AUTOMOBILE INSURANCE (U.S. CLS. 100, 101 AND 102).

FIRST USE 7-0-2010; IN COMMERCE 7-0-2010.

**CLASS 41—EDUCATION AND ENTERTAINMENT**

FOR PROVIDING INFORMATION TO TEEN DRIVERS IN THE FIELD OF DRIVER TRAINING EDUCATION (U.S. CLS. 100, 101 AND 107).

FIRST USE 7-0-2010; IN COMMERCE 7-0-2010.

**CLASS 45—PERSONAL AND LEGAL SERVICES**

FOR PROVIDING INFORMATION TO TEEN DRIVERS IN THE FIELD OF LICENSING REGULATIONS FOR OBTAINING DRIVER'S LICENSES (U.S. CLS. 100 AND 101).

FIRST USE 7-0-2010; IN COMMERCE 7-0-2010.  
JEFFERY COWARD, EXAMINING ATTORNEY

---

SN 85-196,351. JAMES P. OWEN, AUSTIN, TX. FILED 12-13-2010.

# THE TRY

THE MARK CONSISTS OF STANDARD CHARACTERS WITHOUT CLAIM TO ANY PARTICULAR FONT, STYLE, SIZE, OR COLOR.

**CLASS 25—CLOTHING**

FOR CLOTHING, NAMELY, SHIRTS, JACKETS, HATS, CAPS, VESTS, BLOUSES, AND BELTS (U.S. CLS. 22 AND 39).

**CLASS 41—EDUCATION AND ENTERTAINMENT**

FOR EDUCATIONAL AND ENTERTAINMENT SERVICES, NAMELY, PROVIDING MOTIVATIONAL SPEAKING SERVICES AND CLASSES, SEMINARS, WORKSHOPS AND PROGRAMS IN THE FIELDS OF LEADERSHIP, ETHICS, MOTIVATION, INSPIRATION, PERSEVERANCE, VALUES, AND PERSONAL GROWTH AND DEVELOPMENT; PROVIDING RECOGNITION AND INCENTIVES BY THE WAY OF AWARDS TO DEMONSTRATE EXCELLENCE IN THE FIELD OF LEADERSHIP, TO PROMOTE ETHICAL LEADERSHIP, AND TO REWARD PROGRAM PARTICIPANTS (U.S. CLS. 100, 101 AND 107).

GISELLE AGOSTO, EXAMINING ATTORNEY

---

SN 85-196,354. JAMES P. OWEN, AUSTIN, TX. FILED 12-13-2010.

# ALL IT TAKES IS ALL YOU'VE GOT

THE MARK CONSISTS OF STANDARD CHARACTERS WITHOUT CLAIM TO ANY PARTICULAR FONT, STYLE, SIZE, OR COLOR.

**CLASS 25—CLOTHING**

FOR CLOTHING, NAMELY, SHIRTS, JACKETS, HATS, CAPS, VESTS, BLOUSES, AND BELTS (U.S. CLS. 22 AND 39).

**CLASS 41—EDUCATION AND ENTERTAINMENT**

FOR EDUCATIONAL AND ENTERTAINMENT SERVICES, NAMELY, PROVIDING MOTIVATIONAL SPEAKING SERVICES AND CLASSES, SEMINARS, WORKSHOPS AND PROGRAMS IN THE FIELDS OF LEADERSHIP, ETHICS, MOTIVATION, INSPIRATION, PERSEVERANCE, VALUES, AND PERSONAL GROWTH AND DEVELOPMENT; PROVIDING RECOGNITION AND INCENTIVES BY THE WAY OF AWARDS TO DEMONSTRATE EXCELLENCE IN THE FIELD OF LEADERSHIP, TO PROMOTE ETHICAL LEADERSHIP, AND TO REWARD PROGRAM PARTICIPANTS (U.S. CLS. 100, 101 AND 107).

GISELLE AGOSTO, EXAMINING ATTORNEY

---

SN 85-197,724. BOARD OF REGENTS OF THE UNIVERSITY SYSTEM OF GEORGIA, ATLANTA, GA. FILED 12-14-2010.

# VALDOSTA STATE UNIVERSITY

THE MARK CONSISTS OF STANDARD CHARACTERS WITHOUT CLAIM TO ANY PARTICULAR FONT, STYLE, SIZE, OR COLOR.

NO CLAIM IS MADE TO THE EXCLUSIVE RIGHT TO USE "STATE UNIVERSITY", APART FROM THE MARK AS SHOWN.

SEC. 2(F).

**CLASS 14—JEWELRY**

FOR CHARMS; CLOCKS; JEWELRY; RINGS (U.S. CLS. 2, 27, 28 AND 50).

FIRST USE 7-15-1993; IN COMMERCE 7-15-1993.

**CLASS 16—PAPER GOODS AND PRINTED MATTER**

FOR BINDERS; DAY PLANNERS; NOTEBOOKS; PENS (U.S. CLS. 2, 5, 22, 23, 29, 37, 38 AND 50).

FIRST USE 7-15-1993; IN COMMERCE 7-15-1993.

**CLASS 21—HOUSEWARES AND GLASS**

FOR BOWLS; CUPS AND MUGS (U.S. CLS. 2, 13, 23, 29, 30, 33, 40 AND 50).

FIRST USE 7-15-1993; IN COMMERCE 7-15-1993.

**CLASS 22—CORDAGE AND FIBERS**

FOR LANYARDS FOR HOLDING EYEGLASSES, SUNGLASSES, ID CARDS AND TAGS (U.S. CLS. 1, 2, 7, 19, 22, 42 AND 50).

FIRST USE 7-15-1993; IN COMMERCE 7-15-1993.

**CLASS 24—FABRICS**

FOR BANNERS AND FLAGS OF TEXTILE (U.S. CLS. 42 AND 50).

FIRST USE 7-15-1993; IN COMMERCE 7-15-1993.

**CLASS 25—CLOTHING**

FOR HEADGEAR, NAMELY, CAPS AND HATS; SHIRTS; SWEATSHIRTS; T-SHIRTS (U.S. CLS. 22 AND 39).

FIRST USE 7-15-1993; IN COMMERCE 7-15-1993.

**CLASS 41—EDUCATION AND ENTERTAINMENT**

FOR EDUCATIONAL SERVICES, NAMELY, PROVIDING COURSES OF INSTRUCTION AT THE UNIVERSITY LEVEL AND DISTRIBUTION OF COURSE MATERIAL IN CONNECTION THEREWITH; ENTERTAINMENT IN THE NATURE OF COMPETITIONS IN THE FIELD OF ATHLETICS (U.S. CLS. 100, 101 AND 107).

FIRST USE 7-15-1993; IN COMMERCE 7-15-1993.  
SUSAN RICHARDS, EXAMINING ATTORNEY

SN 85-199,949. TLO, LLC, BOCA RATON, FL. FILED 12-16-2010.

**IT'S GOING TO BE MUCH LESS  
SAFE TO BE DANGEROUS**

THE MARK CONSISTS OF STANDARD CHARACTERS WITHOUT CLAIM TO ANY PARTICULAR FONT, STYLE, SIZE, OR COLOR.

**CLASS 38—COMMUNICATION**

FOR PROVIDING ACCESS TO DATABASES (U.S. CLS. 100, 101 AND 104).

FIRST USE 2-0-2010; IN COMMERCE 2-0-2010.

**CLASS 42—SCIENTIFIC AND COMPUTER SERVICES**

FOR COMPUTER SERVICES, NAMELY, PROVIDING SEARCH ENGINES FOR OBTAINING DATA ON A GLOBAL COMPUTER NETWORK (U.S. CLS. 100 AND 101).

FIRST USE 2-0-2010; IN COMMERCE 2-0-2010.  
INGA ERVIN, EXAMINING ATTORNEY

SN 85-200,244. HINKLEY LIGHTING, INC., CLEVELAND, OH. FILED 12-17-2010.

**LIFE AGLOW**

THE MARK CONSISTS OF STANDARD CHARACTERS WITHOUT CLAIM TO ANY PARTICULAR FONT, STYLE, SIZE, OR COLOR.

**CLASS 11—ENVIRONMENTAL CONTROL APPARATUS**

FOR LIGHTING FIXTURES (U.S. CLS. 13, 21, 23, 31 AND 34).

FIRST USE 1-0-2009; IN COMMERCE 1-0-2009.

**CLASS 35—ADVERTISING AND BUSINESS**

FOR DISTRIBUTORSHIP SERVICES IN THE FIELD OF LIGHTING FIXTURES (U.S. CLS. 100, 101 AND 102).  
FIRST USE 1-0-2009; IN COMMERCE 1-0-2009.  
REBECCA EISINGER, EXAMINING ATTORNEY

SN 85-200,454. WHOLE FOODS MARKET IP, L.P., AUSTIN, TX. FILED 12-17-2010.

**THE MORE YOU KNOW, THE  
BETTER**

THE MARK CONSISTS OF STANDARD CHARACTERS WITHOUT CLAIM TO ANY PARTICULAR FONT, STYLE, SIZE, OR COLOR.

**CLASS 29—MEATS AND PROCESSED FOODS**

FOR MEAT, FISH, POULTRY AND SEAFOOD (U.S. CL. 46).

**CLASS 35—ADVERTISING AND BUSINESS**

FOR RETAIL GROCERY STORE SERVICES; PROMOTING AND MARKETING THE GOODS OF OTHERS THROUGH ALL PUBLIC COMMUNICATION MEANS (U.S. CLS. 100, 101 AND 102).

INGA ERVIN, EXAMINING ATTORNEY

SN 85-201,413. AMERICAN HEART ASSOCIATION, DALLAS, TX. FILED 12-19-2010.

**Life's Simple 7**

THE MARK CONSISTS OF STANDARD CHARACTERS WITHOUT CLAIM TO ANY PARTICULAR FONT, STYLE, SIZE, OR COLOR.

**CLASS 16—PAPER GOODS AND PRINTED MATTER**

FOR BROCHURES ABOUT CARDIOVASCULAR HEALTH; INFORMATIONAL FLYERS FEATURING CARDIOVASCULAR HEALTH; POSTERS (U.S. CLS. 2, 5, 22, 23, 29, 37, 38 AND 50).

FIRST USE 2-26-2010; IN COMMERCE 2-26-2010.

**CLASS 41—EDUCATION AND ENTERTAINMENT**

FOR PROVIDING A WEB SITE THAT FEATURES INFORMAL INSTRUCTION ON CARDIOVASCULAR HEALTH (U.S. CLS. 100, 101 AND 107).

FIRST USE 1-31-2010; IN COMMERCE 1-31-2010.  
JESSICA FATHY, EXAMINING ATTORNEY

SN 85-202,701. CULTIVE FRANCHISE, LLC, DAVIS, CA. FILED 12-21-2010.



THE MARK CONSISTS OF A FLOWER WITH EIGHT RADIALLY EXTENDING PEDALS WHEREIN SEVEN ARE THE SAME SIZE AND ONE IS LARGER AND DETACHED FROM THE REMAINDER OF THE FLOWER.

**CLASS 30—STAPLE FOODS**

FOR FROZEN YOGURT AND FROZEN YOGURT BASED DESSERTS (U.S. CL. 46).

**CLASS 43—HOTEL AND RESTAURANT SERVICES**

FOR RESTAURANT SERVICES FEATURING FROZEN YOGURT AND FROZEN YOGURT BASED DESSERTS FOR ON AND OFF PREMISES CONSUMPTION (U.S. CLS. 100 AND 101).

ALEX KEAM, EXAMINING ATTORNEY

SN 85-203,860. GLAXOSMITHKLINE LLC, WILMINGTON, DE. FILED 12-22-2010.

**CONNECTED AT THE HIP**

THE MARK CONSISTS OF STANDARD CHARACTERS WITHOUT CLAIM TO ANY PARTICULAR FONT, STYLE, SIZE, OR COLOR.

**CLASS 9—ELECTRICAL AND SCIENTIFIC APPARATUS**

FOR PROVIDING DOWNLOADABLE ELECTRONIC NEWSLETTERS IN THE FIELD OF NUTRITIONAL SUPPLEMENTS (U.S. CLS. 21, 23, 26, 36 AND 38).

**CLASS 16—PAPER GOODS AND PRINTED MATTER**

FOR PRINTED INSTRUCTIONAL AND EDUCATIONAL MATERIALS IN THE FIELD OF NUTRITIONAL SUPPLEMENTS (U.S. CLS. 2, 5, 22, 23, 29, 37, 38 AND 50).

**CLASS 41—EDUCATION AND ENTERTAINMENT**

FOR PROVIDING ONLINE INSTRUCTIONAL AND EDUCATIONAL PUBLICATIONS, NAMELY MAGAZINES, BOOKS, GUIDES, PAMPHLETS, BROCHURES AND NEWSLETTERS IN THE FIELD OF NUTRITIONAL SUPPLEMENTS (U.S. CLS. 100, 101 AND 107).

TASNEEM HUSSAIN, EXAMINING ATTORNEY

SN 85-208,113. CINTAS HOLDINGS LLC, MASON, OH. FILED 12-30-2010.

**THE SPIRIT IS THE DIFFERENCE**

THE MARK CONSISTS OF STANDARD CHARACTERS WITHOUT CLAIM TO ANY PARTICULAR FONT, STYLE, SIZE, OR COLOR.

**CLASS 35—ADVERTISING AND BUSINESS**

FOR DISTRIBUTORSHIP SERVICES PROVIDING COMMERCIAL AND INDUSTRIAL COMPANIES WITH UNIFORMS, RESTROOM SANITATION SUPPLIES, TOWELS, MATS AND LINENS, FIRST AID SAFETY SUPPLIES AND CLEAN ROOM SUPPLIES (U.S. CLS. 100, 101 AND 102).

FIRST USE 0-0-1991; IN COMMERCE 0-0-1991.

**CLASS 41—EDUCATION AND ENTERTAINMENT**

FOR PROVIDING FIRST AID TRAINING TO COMMERCIAL AND INDUSTRIAL COMPANIES ON A PERIODIC BASIS (U.S. CLS. 100, 101 AND 107).

FIRST USE 0-0-2003; IN COMMERCE 0-0-2003.

**CLASS 45—PERSONAL AND LEGAL SERVICES**

FOR RENTAL OF UNIFORMS TO COMMERCIAL AND INDUSTRIAL COMPANIES (U.S. CLS. 100 AND 101).

FIRST USE 0-0-1991; IN COMMERCE 0-0-1991.

TARA PATE, EXAMINING ATTORNEY

SN 85-208,119. CINTAS HOLDINGS LLC, MASON, OH. FILED 12-30-2010.

**THE SPIRIT IS THE DIFFERENCE**

THE MARK CONSISTS OF STANDARD CHARACTERS WITHOUT CLAIM TO ANY PARTICULAR FONT, STYLE, SIZE, OR COLOR.

**CLASS 37—CONSTRUCTION AND REPAIR**

FOR INSTALLATION AND MAINTENANCE OF FIRE PREVENTION EQUIPMENT, NAMELY, FIRE EXTINGUISHERS, EMERGENCY LIGHTS AND EXIT SIGNS, KITCHEN SUPPRESSION SYSTEMS, FIRE AND SMOKE ALARMS AND SPRINKLER SYSTEMS (U.S. CLS. 100, 103 AND 106).  
FIRST USE 1-3-2011; IN COMMERCE 1-3-2011.

**CLASS 40—MATERIAL TREATMENT**

FOR DOCUMENT SHREDDING SERVICES FOR COMMERCIAL AND INDUSTRIAL COMPANIES (U.S. CLS. 100, 103 AND 106).  
FIRST USE 1-3-2011; IN COMMERCE 1-3-2011.  
TARA PATE, EXAMINING ATTORNEY

SN 85-212,810. ISP INVESTMENTS INC., WILMINGTON, DE. FILED 1-7-2011.

**MELANOGE**

THE MARK CONSISTS OF STANDARD CHARACTERS WITHOUT CLAIM TO ANY PARTICULAR FONT, STYLE, SIZE, OR COLOR.

**CLASS 1—CHEMICALS**

FOR CHEMICAL PRODUCTS FOR USE IN INDUSTRY AND SCIENCE, NAMELY, LINUM USITATISSIMUM SEED EXTRACTS AND HYDROLYZED LINUM USITATISSIMUM SEED PROTEINS FOR USE IN THE MANUFACTURE OF HAIR CARE PRODUCTS AND COSMETIC PREPARATIONS FOR EYE LASHES (U.S. CLS. 1, 5, 6, 10, 26 AND 46).

**CLASS 3—COSMETICS AND CLEANING PREPARATIONS**

FOR NON-MEDICATED HAIR CARE PREPARATIONS, NAMELY, HAIR AND SCALP TREATMENTS, HAIR SHAMPOO, HAIR CONDITIONER, HAIR RINSE, HAIR CREAM, HAIR LOTION AND NON-MEDICATED HAIR SERUMS; HAIR STYLING PREPARATIONS, NAMELY, HAIR GEL, HAIR GLAZE, HAIR MOUSSE, HAIR POMADE, HAIR LACQUER, HAIR PASTE, HAIR FOAM AND HAIR SPRAY; COSMETIC PREPARATIONS FOR EYE LASHES, NAMELY, MASCARA, CONDITIONER AND THICKENER, AND PRIMER (U.S. CLS. 1, 4, 6, 50, 51 AND 52).  
SUNG IN, EXAMINING ATTORNEY

SN 85-212,965. ISP INVESTMENTS INC., WAYNE, NJ. FILED 1-7-2011.

**FOLLISYNC**

THE MARK CONSISTS OF STANDARD CHARACTERS WITHOUT CLAIM TO ANY PARTICULAR FONT, STYLE, SIZE, OR COLOR.

**CLASS 1—CHEMICALS**

FOR CHEMICAL PRODUCTS FOR USE IN INDUSTRY AND SCIENCE, NAMELY, VICIA FABIA SEED EXTRACTS AND HYDROLYZED VICIA FABIA SEED PROTEINS FOR USE IN THE MANUFACTURE OF HAIR CARE PRODUCTS AND COSMETIC PREPARATIONS FOR EYE LASHES (U.S. CLS. 1, 5, 6, 10, 26 AND 46).

**CLASS 3—COSMETICS AND CLEANING PREPARATIONS**

FOR NON MEDICATED HAIR CARE PREPARATIONS, NAMELY, HAIR AND SCALP TREATMENTS, HAIR SHAMPOO, HAIR CONDITIONER, HAIR RINSE, HAIR CREAM, HAIR LOTION AND NON-MEDICATED HAIR SERUMS; HAIR STYLING PREPARATIONS, NAMELY, HAIR GEL, HAIR MOUSSE, HAIR POMADE, HAIR GLAZE, HAIR LACQUER, HAIR PASTE, HAIR FOAM AND HAIR SPRAY; COSMETIC PREPARATIONS FOR EYE LASHES, NAMELY, MASCARA, CONDITIONER AND THICKENER, AND PRIMER (U.S. CLS. 1, 4, 6, 50, 51 AND 52).  
SUNG IN, EXAMINING ATTORNEY

SN 85-214,125. ISP INVESTMENTS INC., WILMINGTON, DE. FILED 1-10-2011.

**PROCATALINE**

THE MARK CONSISTS OF STANDARD CHARACTERS WITHOUT CLAIM TO ANY PARTICULAR FONT, STYLE, SIZE, OR COLOR.

**CLASS 1—CHEMICALS**

FOR CHEMICAL PRODUCTS FOR USE IN INDUSTRY AND SCIENCE, NAMELY, PISUM SATIVUM EXTRACTS AND HYDROLYZED PISUM SATIVUM PROTEINS FOR USE IN THE MANUFACTURE OF HAIR CARE PRODUCTS AND COSMETIC PREPARATIONS FOR EYE LASHES (U.S. CLS. 1, 5, 6, 10, 26 AND 46).

**CLASS 3—COSMETICS AND CLEANING PREPARATIONS**

FOR NON MEDICATED HAIR CARE PREPARATIONS, NAMELY, HAIR AND SCALP TREATMENTS, HAIR SHAMPOO, HAIR CONDITIONER, HAIR RINSE, HAIR CREAM, HAIR LOTION AND NON-MEDICATED HAIR SERUMS; HAIR STYLING PREPARATIONS, NAMELY, HAIR GEL, HAIR MOUSSE, HAIR POMADE, HAIR LACQUER, HAIR PASTE, HAIR GLAZE, HAIR FOAM AND HAIR SPRAY; COSMETIC PREPARATIONS FOR EYE LASHES, NAMELY, MASCARA, CONDITIONER AND THICKENER, AND PRIMER (U.S. CLS. 1, 4, 6, 50, 51 AND 52).  
SUNG IN, EXAMINING ATTORNEY



SN 85-219,893. ANSELL LIMITED, RICHMOND, AUSTRALIA, FILED 1-18-2011.

## ACTIVARMAR

THE MARK CONSISTS OF STANDARD CHARACTERS WITHOUT CLAIM TO ANY PARTICULAR FONT, STYLE, SIZE, OR COLOR.

### CLASS 9—ELECTRICAL AND SCIENTIFIC APPARATUS

FOR INDUSTRIAL PROTECTIVE WORK GLOVES (U.S. CLS. 21, 23, 26, 36 AND 38).

### CLASS 21—HOUSEWARES AND GLASS

FOR WORK GLOVES FOR GENERAL PURPOSE USE (U.S. CLS. 2, 13, 23, 29, 30, 33, 40 AND 50).  
SEAN CROWLEY, EXAMINING ATTORNEY

SN 85-221,415. FRITO-LAY NORTH AMERICA, INC., PLANO, TX. FILED 1-19-2011.

## ENJOY SOMETHING NEW

THE MARK CONSISTS OF STANDARD CHARACTERS WITHOUT CLAIM TO ANY PARTICULAR FONT, STYLE, SIZE, OR COLOR.

### CLASS 29—MEATS AND PROCESSED FOODS

FOR NUT-BASED SNACK FOODS; POTATO-BASED SNACK FOODS; PROCESSED EDIBLE SEEDS (U.S. CL. 46).

### CLASS 30—STAPLE FOODS

FOR CEREAL-BASED SNACK FOODS; CHEESE-FLAVORED CORN SNACKS; CORN-BASED SNACK FOODS; FLOUR-BASED CHIPS; MULTIGRAIN-BASED SNACK FOODS; PRETZELS; RICE-BASED SNACK FOODS; WHEAT-BASED SNACK FOODS (U.S. CL. 46).  
TEJBIR SINGH, EXAMINING ATTORNEY

SN 85-221,704. JOHNSON MANAGEMENT GROUP, INC., ATLANTA, GA. FILED 1-20-2011.

## FAMINGLE

THE MARK CONSISTS OF STANDARD CHARACTERS WITHOUT CLAIM TO ANY PARTICULAR FONT, STYLE, SIZE, OR COLOR.

### CLASS 41—EDUCATION AND ENTERTAINMENT

FOR ARRANGING AND CONDUCTING NIGHTCLUB ENTERTAINMENT EVENTS; ARRANGING AND CONDUCTING SPECIAL EVENTS FOR SOCIAL ENTERTAINMENT PURPOSES; ARRANGING FOR TICKET RESERVATIONS FOR SHOWS AND OTHER ENTERTAINMENT EVENTS; ARRANGING, ORGANIZING, CONDUCTING, AND HOSTING SOCIAL ENTERTAINMENT EVENTS; DIRECTION OF MAKING RADIO OR TELEVISION PROGRAMS; DISTRIBUTION OF RADIO PROGRAMS FOR OTHERS; DISTRIBUTION OF TELEVISION PROGRAMMING TO CABLE TELEVISION SYSTEMS; DISTRIBUTION OF TELEVISION PROGRAMS FOR OTHERS; ENTERTAINMENT AND EDUCATIONAL SERVICES, NAMELY, PROVIDING ADVICE AND INFORMATION FOR MUSIC, VIDEO AND FILM CONCEPT AND SCRIPT DEVELOPMENT; ENTERTAINMENT IN THE NATURE OF VISUAL AND AUDIO PERFORMANCES, AND MUSICAL, VARIETY, NEWS AND COMEDY SHOWS; ENTERTAINMENT IN THE NATURE OF VISUAL AND AUDIO PERFORMANCES, NAMELY, MUSICAL BAND, ROCK GROUP, GYMNASIUM, DANCE, AND BALLET PERFORMANCES; ENTERTAINMENT INFORMATION SERVICES, NAMELY, PROVIDING INFORMATION AND NEWS RELEASES ABOUT A MUSICAL ARTIST; ENTERTAINMENT SERVICES BY A MUSICAL ARTIST AND PRODUCER, NAMELY, MUSICAL COMPOSITION FOR OTHERS AND PRODUCTION OF MUSICAL SOUND RECORDINGS; ENTERTAINMENT SERVICES IN THE NATURE OF CREATION, DEVELOPMENT, AND PRODUCTION OF TELEVISION PROGRAMMING; ENTERTAINMENT SERVICES IN THE NATURE OF LIVE MUSICAL PERFORMANCES; ENTERTAINMENT SERVICES IN THE NATURE OF PRESENTING LIVE MUSICAL PERFORMANCES; ENTERTAINMENT SERVICES IN THE NATURE OF RECORDING, PRODUCTION AND POST-PRODUCTION SERVICES IN THE FIELD OF MUSIC; ENTERTAINMENT, NAMELY, LIVE MUSIC CONCERTS; ENTERTAINMENT, NAMELY, LIVE PERFORMANCES BY MUSICAL BANDS; LIVE PERFORMANCES BY A MUSICAL GROUP; MULTIMEDIA ENTERTAINMENT SERVICES IN THE NATURE OF RECORDING, PRODUCTION AND POST-PRODUCTION SERVICES IN THE FIELDS OF MUSIC, VIDEO, AND FILMS; MULTIMEDIA PUBLISHING OF BOOKS, MAGAZINES, JOURNALS, SOFTWARE, GAMES, MUSIC, AND ELECTRONIC PUBLICATIONS. MUSIC COMPOSITION AND TRANSCRIPTION FOR OTHERS; MUSIC COMPOSITION FOR OTHERS; MUSIC PRODUCTION SERVICES; MUSIC PUBLISHING SERVICES; MUSIC SELECTION SERVICES FOR USE IN TELEVISION, FILM, RADIO AND VIDEO GAMES; MUSIC VIDEO PRODUCTION; PRODUCTION OF MUSICAL VIDEOS; PRODUCTION OF RADIO AND TELEVISION PROGRAMS; PRODUCTION OF SOUND AND MUSIC VIDEO RECORDINGS; PROVIDING A WEBSITE FEATURING INFORMATION IN THE FIELD OF MUSIC AND ENTERTAINMENT; RADIO ENTERTAINMENT PRODUCTION (U.S. CLS. 100, 101 AND 107).

### CLASS 45—PERSONAL AND LEGAL SERVICES

FOR INTERNET-BASED SOCIAL NETWORKING SERVICES (U.S. CLS. 100 AND 101).  
ARETHA SOMERVILLE, EXAMINING ATTORNEY

SN 85-223,142. CHW, LLC, CHARLOTTE, NC. FILED 1-21-2011.

SN 85-223,161. CHW, LLC, CHARLOTTE, NC. FILED 1-21-2011.



THE MARK CONSISTS OF A STYLIZED LETTER "V" IN A CIRCLE.

**CLASS 3—COSMETICS AND CLEANING PREPARATIONS**

FOR COSMETICS, PERFUMES, COLOGNES, COMPACT CONTAINING COSMETICS (U.S. CLS. 1, 4, 6, 50, 51 AND 52).

**CLASS 9—ELECTRICAL AND SCIENTIFIC APPARATUS**

FOR SUNGLASSES (U.S. CLS. 21, 23, 26, 36 AND 38).

**CLASS 14—JEWELRY**

FOR JEWELRY (U.S. CLS. 2, 27, 28 AND 50).

**CLASS 16—PAPER GOODS AND PRINTED MATTER**

FOR STATIONERY, NOTE PADS, NOTE CARDS, PENS AND PENCILS (U.S. CLS. 2, 5, 22, 23, 29, 37, 38 AND 50).

**CLASS 18—LEATHER GOODS**

FOR HANDBAGS, WALLETS, COSMETIC CASES SOLD EMPTY (U.S. CLS. 1, 2, 3, 22 AND 41).

**CLASS 21—HOUSEWARES AND GLASS**

FOR COMPACTS SOLD EMPTY, WINE GLASSES, CHAMPAGNE FLUTES, MUGS, TEA CUPS (U.S. CLS. 2, 13, 23, 29, 30, 33, 40 AND 50).

**CLASS 25—CLOTHING**

FOR BELTS, FOOTWEAR, SCARVES (U.S. CLS. 22 AND 39).

**CLASS 26—FANCY GOODS**

FOR HAIR ACCESSORIES, NAMELY, HAIR RIBBONS, ELASTICS, ORNAMENTS, SCRUNCHIES, BARRETTES, CLIPS, BANDS, STICKS AND BOWS (U.S. CLS. 37, 39, 40, 42 AND 50).

**CLASS 35—ADVERTISING AND BUSINESS**

FOR RETAIL STORE SERVICES FEATURING WOMEN'S ACCESSORIES, GIFTS AND CLOTHING (U.S. CLS. 100, 101 AND 102).  
MORGAN WYNNE, EXAMINING ATTORNEY



NO CLAIM IS MADE TO THE EXCLUSIVE RIGHT TO USE "ACCESSORIES", APART FROM THE MARK AS SHOWN.

THE MARK CONSISTS OF THE STYLIZED LETTER "V" IN A CIRCLE WITH THE WORDS "VERSONA ACCESSORIES".

**CLASS 3—COSMETICS AND CLEANING PREPARATIONS**

FOR COSMETICS, PERFUMES, COLOGNES, COMPACT CONTAINING COSMETICS (U.S. CLS. 1, 4, 6, 50, 51 AND 52).

**CLASS 9—ELECTRICAL AND SCIENTIFIC APPARATUS**

FOR SUNGLASSES (U.S. CLS. 21, 23, 26, 36 AND 38).

**CLASS 14—JEWELRY**

FOR JEWELRY (U.S. CLS. 2, 27, 28 AND 50).

**CLASS 16—PAPER GOODS AND PRINTED MATTER**

FOR STATIONERY, NOTE PADS, NOTE CARDS, PENS AND PENCILS (U.S. CLS. 2, 5, 22, 23, 29, 37, 38 AND 50).

**CLASS 18—LEATHER GOODS**

FOR HANDBAGS, WALLETS, COSMETIC CASES SOLD EMPTY (U.S. CLS. 1, 2, 3, 22 AND 41).

**CLASS 21—HOUSEWARES AND GLASS**

FOR COMPACTS SOLD EMPTY, WINE GLASSES, CHAMPAGNE FLUTES, MUGS, TEA CUPS (U.S. CLS. 2, 13, 23, 29, 30, 33, 40 AND 50).

**CLASS 25—CLOTHING**

FOR BELTS, FOOTWEAR, SCARVES (U.S. CLS. 22 AND 39).

**CLASS 26—FANCY GOODS**

FOR HAIR ACCESSORIES, NAMELY, HAIR RIBBONS, ELASTICS, ORNAMENTS, SCRUNCHIES, BARRETTES, CLIPS, BANDS, STICKS AND BOWS (U.S. CLS. 37, 39, 40, 42 AND 50).

**CLASS 35—ADVERTISING AND BUSINESS**

FOR RETAIL STORE SERVICES FEATURING WOMEN'S ACCESSORIES, GIFTS AND CLOTHING (U.S. CLS. 100, 101 AND 102).  
MORGAN WYNNE, EXAMINING ATTORNEY

SN 85-223,174. CHW, LLC, CHARLOTTE, NC. FILED 1-21-2011.

SN 85-225,017. BARNEY'S, INC., NEW YORK, NY. FILED 1-24-2011.



## VERSONA ACCESSORIES

NO CLAIM IS MADE TO THE EXCLUSIVE RIGHT TO USE "ACCESSORIES", APART FROM THE MARK AS SHOWN.

THE MARK CONSISTS OF THE STYLIZED LETTER "V" APPEARING ABOVE THE WORDS "VERSONA ACCESSORIES".

### CLASS 3—COSMETICS AND CLEANING PREPARATIONS

FOR COSMETICS, PERFUMES, COLOGNES, COMPACTS CONTAINING COSMETICS (U.S. CLS. 1, 4, 6, 50, 51 AND 52).

### CLASS 9—ELECTRICAL AND SCIENTIFIC APPARATUS

FOR SUNGLASSES (U.S. CLS. 21, 23, 26, 36 AND 38).

### CLASS 14—JEWELRY

FOR JEWELRY (U.S. CLS. 2, 27, 28 AND 50).

### CLASS 16—PAPER GOODS AND PRINTED MATTER

FOR STATIONERY, NOTE PADS, NOTE CARDS, PENS AND PENCILS (U.S. CLS. 2, 5, 22, 23, 29, 37, 38 AND 50).

### CLASS 18—LEATHER GOODS

FOR HANDBAGS, WALLETS, COSMETIC CASES SOLD EMPTY (U.S. CLS. 1, 2, 3, 22 AND 41).

### CLASS 21—HOUSEWARES AND GLASS

FOR COMPACTS SOLD EMPTY, WINE GLASSES, CHAMPAGNE FLUTES, MUGS, TEA CUPS (U.S. CLS. 2, 13, 23, 29, 30, 33, 40 AND 50).

### CLASS 25—CLOTHING

FOR BELTS, FOOTWEAR, SCARVES (U.S. CLS. 22 AND 39).

### CLASS 26—FANCY GOODS

FOR HAIR ACCESSORIES, NAMELY, HAIR RIBBONS, ELASTICS, ORNAMENTS, SCRUNCHIES, BARRETTES, CLIPS, BANDS, STICKS AND BOWS (U.S. CLS. 37, 39, 40, 42 AND 50).

### CLASS 35—ADVERTISING AND BUSINESS

FOR RETAIL STORE SERVICES FEATURING WOMEN'S ACCESSORIES, GIFTS AND CLOTHING (U.S. CLS. 100, 101 AND 102).  
MORGAN WYNNE, EXAMINING ATTORNEY

## GET DOWN TO BUSINESS

THE MARK CONSISTS OF STANDARD CHARACTERS WITHOUT CLAIM TO ANY PARTICULAR FONT, STYLE, SIZE, OR COLOR.

### CLASS 35—ADVERTISING AND BUSINESS

FOR FASHION SHOW EXHIBITIONS FOR COMMERCIAL PURPOSES; RETAIL STORE SERVICES FEATURING CLOTHING (U.S. CLS. 100, 101 AND 102).

### CLASS 40—MATERIAL TREATMENT

FOR TAILORING SERVICES (U.S. CLS. 100, 103 AND 106).  
B. PARADEWELAI, EXAMINING ATTORNEY

---

SN 85-225,054. DUFFY HOLDINGS LLC, WHITEHALL, PA. FILED 1-24-2011.

## TASTEFULS

THE MARK CONSISTS OF STANDARD CHARACTERS WITHOUT CLAIM TO ANY PARTICULAR FONT, STYLE, SIZE, OR COLOR.

### CLASS 3—COSMETICS AND CLEANING PREPARATIONS

FOR BREATH MINTS FOR USE AS A BREATH FRESHENER (U.S. CLS. 1, 4, 6, 50, 51 AND 52).

### CLASS 5—PHARMACEUTICALS

FOR DIETARY AND NUTRITIONAL SUPPLEMENTS (U.S. CLS. 6, 18, 44, 46, 51 AND 52).

### CLASS 29—MEATS AND PROCESSED FOODS

FOR JELLIES AND JAMS (U.S. CL. 46).

### CLASS 30—STAPLE FOODS

FOR CAKE FROSTING; CAKES; CANDY; CHEWING GUMS; FLAVORING SYRUP (U.S. CL. 46).

### CLASS 32—LIGHT BEVERAGES

FOR FRUIT FLAVORED DRINKS (U.S. CLS. 45, 46 AND 48).  
DAVID COLLIER, EXAMINING ATTORNEY

SN 85-226,100. MY GOODNESS, LLC, ERWIN, TN. FILED 1-25-2011.

SN 85-228,914. BEHR PROCESS CORPORATION, SANTA ANA, CA. FILED 1-28-2011.

QTR

THE MARK CONSISTS OF STANDARD CHARACTERS WITHOUT CLAIM TO ANY PARTICULAR FONT, STYLE, SIZE, OR COLOR.

**CLASS 18—LEATHER GOODS**

FOR TOTE BAGS (U.S. CLS. 1, 2, 3, 22 AND 41).

**CLASS 25—CLOTHING**

FOR T-SHIRTS; HATS (U.S. CLS. 22 AND 39).  
H. M. FISHER, EXAMINING ATTORNEY



OWNER OF U.S. REG. NOS. 942,246, 1,551,547 AND OTHERS.

THE MARK CONSISTS OF A BLACK SQUARE WITH A DRAWING OF A BEAR IN THE CENTER NEXT TO A SQUARE CONTAINING THE WORDING "BEHRPRO".

**CLASS 37—CONSTRUCTION AND REPAIR**

FOR PAINTING CONTRACTOR SERVICES (U.S. CLS. 100, 103 AND 106).

**CLASS 39—TRANSPORTATION AND STORAGE**

FOR DISTRIBUTION SERVICES, NAMELY, DELIVERY OF PAINT (U.S. CLS. 100 AND 105).  
JAY FLOWERS, EXAMINING ATTORNEY

SN 85-228,911. BEHR PROCESS CORPORATION, SANTA ANA, CA. FILED 1-28-2011.

SN 85-228,972. WATSON PHARMACEUTICALS, INC., CORONA, CA. FILED 1-28-2011.



BehrPro

OWNER OF U.S. REG. NOS. 942,246, 1,551,547 AND OTHERS.

THE MARK CONSISTS OF A BLACK SQUARE WITH A DRAWING OF A BEAR IN THE CENTER ON TOP OF A SQUARE CONTAINING THE WORDING "BEHRPRO".

**CLASS 37—CONSTRUCTION AND REPAIR**

FOR PAINTING CONTRACTOR SERVICES (U.S. CLS. 100, 103 AND 106).

**CLASS 39—TRANSPORTATION AND STORAGE**

FOR DISTRIBUTION SERVICES, NAMELY, DELIVERY OF PAINT (U.S. CLS. 100 AND 105).  
JAY FLOWERS, EXAMINING ATTORNEY

I AM GENERESS

THE MARK CONSISTS OF STANDARD CHARACTERS WITHOUT CLAIM TO ANY PARTICULAR FONT, STYLE, SIZE, OR COLOR.

**CLASS 35—ADVERTISING AND BUSINESS**

FOR PROMOTING THE CHARITABLE SERVICES OF OTHERS, NAMELY, PROVIDING INDIVIDUALS WITH INFORMATION FOR THE PURPOSE OF MAKING DONATIONS TO CHARITIES (U.S. CLS. 100, 101 AND 102).

**CLASS 36—INSURANCE AND FINANCIAL**

FOR CHARITABLE FUNDRAISING SERVICES (U.S. CLS. 100, 101 AND 102).

**CLASS 45—PERSONAL AND LEGAL SERVICES**

FOR PROVIDING A SOCIAL NETWORKING WEBSITE AT WHICH A USER CAN GIVE CHARITABLE GIFTS TO OTHERS (U.S. CLS. 100 AND 101).  
CHERYL CLAYTON, EXAMINING ATTORNEY

SN 85-248,031. ANSELL LIMITED, RICHMOND, AUSTRALIA, FILED 2-22-2011.

SN 85-248,082. ANSELL LIMITED, RICHMOND, AUSTRALIA, FILED 2-22-2011.

**LIFESTYLES MISS CHACHA**

**LIFESTYLES MR. WILLY**

THE MARK CONSISTS OF STANDARD CHARACTERS WITHOUT CLAIM TO ANY PARTICULAR FONT, STYLE, SIZE, OR COLOR.  
OWNER OF U.S. REG. NOS. 1,185,626, 3,534,659 AND OTHERS.

THE MARK CONSISTS OF STANDARD CHARACTERS WITHOUT CLAIM TO ANY PARTICULAR FONT, STYLE, SIZE, OR COLOR.  
OWNER OF U.S. REG. NOS. 1,185,626, 3,534,659 AND OTHERS.

**CLASS 3—COSMETICS AND CLEANING PREPARATIONS**

FOR MESSAGE GELS OTHER THAN FOR MEDICAL PURPOSES (U.S. CLS. 1, 4, 6, 50, 51 AND 52).

**CLASS 5—PHARMACEUTICALS**

FOR MEDICATED, MALE DESENSITIZING AGENT FOR CLIMAX CONTROL (U.S. CLS. 6, 18, 44, 46, 51 AND 52).

**CLASS 5—PHARMACEUTICALS**

FOR PERSONAL SEXUAL LUBRICANTS (U.S. CLS. 6, 18, 44, 46, 51 AND 52).  
SEAN CROWLEY, EXAMINING ATTORNEY

**CLASS 10—MEDICAL APPARATUS**

FOR CONDOMS AND ADULT SEXUAL AIDS, NAMELY, SILICONE VIBRATING PENILE RINGS AND DEVICES (U.S. CLS. 26, 39 AND 44).  
SEAN CROWLEY, EXAMINING ATTORNEY

\* \* \* \* \*

## SECTION 2.— INTERNATIONAL CLASSIFICATION

The short titles associated below with the international class numbers are terms designed merely for quick identification and are not an official part of the international classification. The full names of international classes are given in section 6.1 of the trademark rules of practice.

The designation "U.S. Cl." appearing in this section refers to the U.S. class in effect prior to Sep. 1, 1973 rather than the international class which applies to applications filed on or after that date. For adoption of international classification see notice in the OFFICIAL GAZETTE of Jun. 26, 1973 (911 O.G. TM 210).

### Application in one class

#### CLASS 1—CHEMICALS

SN 76-703,707. LEE, DANIEL E., PHOENIX, AZ. FILED 7-8-2010.

#### CLASS 1—(Continued).

SN 77-628,548. AHRAM BIOSYSTEMS, INC., SEOUL, REPUBLIC OF KOREA, FILED 12-8-2008.

# Ahram



NO CLAIM IS MADE TO THE EXCLUSIVE RIGHT TO USE "LIQUID", APART FROM THE MARK AS SHOWN. THE STIPPLING IS FOR SHADING PURPOSES.

THE MARK CONSISTS OF THE WORDING "LIQUID EARTHWORMS" WITH STYLIZED DEPICTIONS OF EARTHWORMS.

FOR SOIL CONDITIONERS AND ACTIVATORS FOR AGRICULTURAL AND HORTICULTURAL USE (U.S. CLS. 1, 5, 6, 10, 26 AND 46).

FIRST USE 2-6-1991; IN COMMERCE 3-1-1991.

JOHN E. MICHOS, EXAMINING ATTORNEY

THE MARK CONSISTS OF STANDARD CHARACTERS WITHOUT CLAIM TO ANY PARTICULAR FONT, STYLE, SIZE, OR COLOR.

PRIORITY CLAIMED UNDER SEC. 44(D) ON REPUBLIC OF KOREA APPLICATION NO. 40-2008-0027, FILED 6-9-2008, REG. NO. 40-0813532, DATED 2-5-2010, EXPIRES 2-5-2020.

THE ENGLISH TRANSLATION OF "AHRAM" IN THE MARK IS "FULLY RIPENED STATE OF CHESTNUTS OR ACORNS"; OR "FULLY RIPENED CHESTNUTS OR ACORNS".

FOR REAGENTS AND PREPARATIONS FOR USE IN LIFE SCIENCE RESEARCH, NAMELY, AMINO ACIDS, NUCLEIC ACIDS, RECOMBINANT GENES, RECOMBINANT PROTEINS, GENE VECTORS, TRANSFORMED CELLS, AND CELL LINES; ENZYMES FOR LIFE SCIENCE RESEARCH; ANTI-AGING AGENTS FOR USE IN THE MANUFACTURE OF COSMETICS; CHEMICAL REAGENTS OTHER THAN FOR MEDICAL PURPOSES; ORGANIC ACIDS, NAMELY, ORGANIC ACID SALTS FOR USE IN LIFE SCIENCE RESEARCH; PHOSPHATIDES; SULPHIDES; GERMINATION INHIBITORS AS ANTI-SPROUTING AGENTS; PLANT GROWTH REGULATORS FOR AGRICULTURAL USE; CHEMICAL REAGENTS AND CHEMICAL REAGENT KITS FOR BIOTECHNOLOGY RESEARCH COMPRISED OF DNA PRIMERS, DNA POLYMERASE, AND BUFFERS; BIOCHEMICAL AND DIAGNOSTIC REAGENTS FOR PROTEIN DETECTION; REAGENT KITS FOR PROTEIN DETECTION COMPRISED OF REPORTER GENES, REPORTER PROTEINS, AND REPORTER MOLECULES; BIOCHEMICAL AND DIAGNOSTIC REAGENTS FOR PROTEIN SEPARATION; AND REAGENT KITS FOR PROTEIN SEPARATION COMPRISED OF AFFINITY COLUMNS AND BUFFERS (U.S. CLS. 1, 5, 6, 10, 26 AND 46).

CARYN GLASSER, EXAMINING ATTORNEY

**CLASS 1—(Continued).**

SN 77-951,776. AGDIA, INC., ELKHART, IN. FILED 3-5-2010.

 The logo for "Amplify RP" features the word "Amplify" in a green, sans-serif font. To its right is a blue, stylized graphic element resembling a curved line or a partial circle. Further right, the letters "RP" are enclosed in a grey square.

NO CLAIM IS MADE TO THE EXCLUSIVE RIGHT TO USE "AMPLIFY", APART FROM THE MARK AS SHOWN.

THE COLOR(S) GREEN, BLUE, GREY, WHITE IS/ARE CLAIMED AS A FEATURE OF THE MARK.

THE MARK CONSISTS OF THE WORD "AMPLIFY" IN THE COLOR GREEN. TO THE RIGHT OF THE WORD "AMPLIFY" A GREY SQUARE APPEARS WITH THE LETTERS "RP" IN THE COLOR WHITE. DISSECTING THE LEFT EDGE OF THE GREY SQUARE AND TO THE RIGHT OF THE WORD "AMPLIFY", A FREEFORM CURVING LINE IN THE COLOR BLUE BEGINS ABOVE THE LETTER "Y" CURVING VERTICALLY FROM LEFT TO RIGHT AND LEFT TO RIGHT AGAIN ENDING OVER THE LOWER LEFT SIDE OF THE LETTER "R".

FOR NUCLEIC ACID DIAGNOSTIC PRODUCTS, NAMELY, PRE-MIXED REACTANTS AND REAGENTS FOR COMMERCIAL, SCIENTIFIC, AND RESEARCH USE IN CONNECTION WITH AMPLIFICATION OR DETECTION OF NUCLEIC ACID AND KITS COMPRISING PRE-MIXED REACTANTS AND REAGENTS IN CONNECTION WITH AMPLIFICATION OR DETECTION OF NUCLEIC ACIDS FOR COMMERCIAL, SCIENTIFIC, AND RESEARCH USE FOR DETECTION OR ANALYSIS OF PLANT PATHOGEN DNA OR RNA OR PLANT GMO TRAITS (U.S. CLS. 1, 5, 6, 10, 26 AND 46).

KEVIN DINALLO, EXAMINING ATTORNEY

SN 77-954,346. SULPHUR MILLS LTD., MUMBAI, INDIA, FILED 3-9-2010.

# ROTATE

THE MARK CONSISTS OF STANDARD CHARACTERS WITHOUT CLAIM TO ANY PARTICULAR FONT, STYLE, SIZE, OR COLOR.

FOR FUNGICIDE FOR THE CONTROL OF LEAF SPOT AND RUST AND OTHER DISEASES ON PEANUTS, PECANS, BARLEY, AND WHEAT, FUNGICIDE FOR THE CONTROL OF LEAF SPOT AND RUST AND OTHER DISEASES ON AGRICULTURAL CROPS (U.S. CLS. 1, 5, 6, 10, 26 AND 46).

SEAN CROWLEY, EXAMINING ATTORNEY

**CLASS 1—(Continued).**

SN 79-087,200. SAES GETTERS S.P.A., I-20020 LAINATE (MI), ITALY, FILED 7-1-2010.

# ZeoGlue

THE MARK CONSISTS OF STANDARD CHARACTERS WITHOUT CLAIM TO ANY PARTICULAR FONT, STYLE, SIZE, OR COLOR.

PRIORITY DATE OF 6-28-2010 IS CLAIMED.

OWNER OF INTERNATIONAL REGISTRATION 1050684 DATED 7-1-2010, EXPIRES 7-1-2020.

FOR UNPROCESSED ARTIFICIAL RESINS; UNPROCESSED ARTIFICIAL RESIN COMPOUNDS USED IN INDUSTRY FOR PERFECTING AND MAINTAINING A VACUUM; CHEMICALS USED IN INDUSTRY FOR PERFECTING AND MAINTAINING VACUUM; CHEMICALS USED IN INDUSTRY FOR PROTECTION AGAINST MOISTURE AND IMPURITIES (U.S. CLS. 1, 5, 6, 10, 26 AND 46).

PAUL MORENO, EXAMINING ATTORNEY

SN 79-089,771. FUJIAN YUANLI ACTIVE CARBON CO.,LTD., CHINA, FILED 9-24-2010.

 The Chinese characters "元力" (Yuan Li) are written in a bold, black, traditional calligraphic style.

OWNER OF INTERNATIONAL REGISTRATION 1057717 DATED 9-24-2010, EXPIRES 9-24-2020.

THE MARK CONSISTS OF TWO CHINESE CHARACTERS, THE FIRST CHARACTER MEANS VITALITY, THE SECOND CHARACTER MEANS POWER.

THE ENGLISH TRANSLATION OF THE FIRST CHINESE CHARACTER MEANS "VITALITY", THE SECOND CHARACTER MEANS "POWER".

THE TRANSLITERATION OF THE NON-LATIN CHARACTERS IN THE MARK IS "YUAN LI".

FOR ACTIVATED CARBONS FOR GENERAL INDUSTRIAL USE (U.S. CLS. 1, 5, 6, 10, 26 AND 46).

CHRISTOPHER BUONGIORNO, EXAMINING ATTORNEY

SN 79-091,208. CHEMICAL & MINING SERVICES PTY LIMITED, AUSTRALIA, FILED 11-11-2010.

# INTERFROTH

THE MARK CONSISTS OF STANDARD CHARACTERS WITHOUT CLAIM TO ANY PARTICULAR FONT, STYLE, SIZE, OR COLOR.

OWNER OF INTERNATIONAL REGISTRATION 1061565 DATED 11-11-2010, EXPIRES 11-11-2020.

FOR FROTH FLOTATION AGENTS; FROTH FLOTATION AGENTS USED IN THE SEPARATION OF BASE METALS, PRECIOUS METALS, MINERAL SANDS, GLASS SANDS, IRON ORE, POTASH, PHOSPHATE, COAL, GRAPHITE AND DIAMONDS FROM OTHER MINERALS (U.S. CLS. 1, 5, 6, 10, 26 AND 46).

PRISCILLA MILTON, EXAMINING ATTORNEY

**CLASS 1—(Continued).**

SN 85-011,223. MJB BOTANICALS, LAKE GENEVA, WI.  
FILED 4-11-2010.

**MJB-Botanicals**

THE MARK CONSISTS OF STANDARD CHARACTERS WITHOUT CLAIM TO ANY PARTICULAR FONT, STYLE, SIZE, OR COLOR.

FOR PLANT AND HERB EXTRACTS FOR USE IN THE MANUFACTURE OF COSMETICS; PLANT EXTRACTS FOR USE IN THE MANUFACTURE OF CREAMS, LOTIONS AND COSMETIC PRODUCTS; PLANT EXTRACTS, NAMELY, MEDICINAL, USED IN THE MANUFACTURE OF NATURAL MEDICINE (U.S. CLS. 1, 5, 6, 10, 26 AND 46).

FIRST USE 1-1-2000; IN COMMERCE 1-1-2000.  
JANICE KIM, EXAMINING ATTORNEY

---

SN 85-019,815. AVGRO LLC, JOLIET, IL. FILED 4-21-2010.

**AVGRO**

THE MARK CONSISTS OF STANDARD CHARACTERS WITHOUT CLAIM TO ANY PARTICULAR FONT, STYLE, SIZE, OR COLOR.

FOR SOIL AMENDMENTS FOR USE WITH SOIL, CLAY, SAND; SOIL STABILIZING AGENTS FOR USE WITH SOIL, CLAY AND SAND; FERTILIZING AGENTS IN THE NATURE OF NUTRITIVE ADDITIVES TO ENHANCE THE BIOLOGICAL ACTIVITY OF SOIL, CLAY, SAND AND WATER (U.S. CLS. 1, 5, 6, 10, 26 AND 46).

ELIZABETH HUGHITT, EXAMINING ATTORNEY

---

SN 85-023,932. INNOVATIVE MUNICIPAL PRODUCTS (U.S.), INC., AJAX, PROVINCE ONTARIO, CANADA, FILED 4-27-2010.

**PROMELT ULTRA**

THE MARK CONSISTS OF STANDARD CHARACTERS WITHOUT CLAIM TO ANY PARTICULAR FONT, STYLE, SIZE, OR COLOR.

FOR DEICING PREPARATIONS FOR MELTING AND CREATING TRACTION ON SNOW AND ICE, ON OUTDOOR SURFACES (U.S. CLS. 1, 5, 6, 10, 26 AND 46).

FIRST USE 1-27-2004; IN COMMERCE 1-27-2004.  
WILLIAM VERHOSEK, EXAMINING ATTORNEY

**CLASS 1—(Continued).**

SN 85-028,558. QUANTIMETRIX CORPORATION, REDONDO BEACH, CA. FILED 5-3-2010.

**DROPPER**

THE MARK CONSISTS OF STANDARD CHARACTERS WITHOUT CLAIM TO ANY PARTICULAR FONT, STYLE, SIZE, OR COLOR.

SEC. 2(F).  
FOR CALIBRATING AND QUALITY CONTROL FLUIDS FOR CLINICAL LABORATORY URINE DIPSTICKS (U.S. CLS. 1, 5, 6, 10, 26 AND 46).

FIRST USE 12-1-1991; IN COMMERCE 12-1-1991.  
DOUGLAS LEE, EXAMINING ATTORNEY

---

SN 85-057,924. ANTHONY WILLIAMS, WESTMINSTER, CO. FILED 6-8-2010.

**POWER CURVE**

THE MARK CONSISTS OF STANDARD CHARACTERS WITHOUT CLAIM TO ANY PARTICULAR FONT, STYLE, SIZE, OR COLOR.

FOR CHEMICAL ENGINE TREATMENTS AND ADDITIVES FOR ENGINE OILS, GASOLINE AND DIESEL FUELS, TRANSMISSION FLUIDS AND COOLING SYSTEMS (U.S. CLS. 1, 5, 6, 10, 26 AND 46).

FIRST USE 8-20-2008; IN COMMERCE 8-20-2008.  
KEVIN CORWIN, EXAMINING ATTORNEY



**CLASS 1—(Continued).**

SN 85-094,087. LATOUR, LUIS M., DORAL, FL. FILED 7-27-2010.

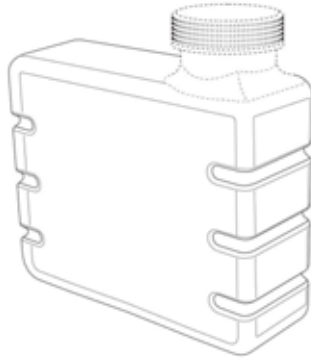

THE MARK CONSISTS OF THE THREE-DIMENSIONAL CONFIGURATION OF A RADIATOR SHAPED CONTAINER, USED AS PACKAGING FOR THE GOODS. THE MATTER SHOWN IN BROKEN LINES; I.E., THE CAP AND NECK OF THE CONTAINER, IS NOT PART OF THE MARK AND SHOWS ONLY POSITION OF THOSE ELEMENTS IN THE MARK.

FOR CHEMICAL RADIATOR TREATMENT ADDITIVE FOR AUTOMOBILE ENGINES (U.S. CLS. 1, 5, 6, 10, 26 AND 46).

ELLEN BURNS, EXAMINING ATTORNEY

SN 85-120,847. ARR-MAZ PRODUCTS, L.P., MULBERRY, FL. FILED 9-1-2010.

# ARRMULS

THE MARK CONSISTS OF STANDARD CHARACTERS WITHOUT CLAIM TO ANY PARTICULAR FONT, STYLE, SIZE, OR COLOR.

FOR ASPHALT ADDITIVES THAT MODIFY EMULSION CHARACTERISTICS IN ASPHALT CEMENTS AND AID IN THE PRODUCTION OF CLIMATE RESPONSIVE MICROSURFACING EMULSIONS FOR USE IN THE ASPHALT AND PAVING INDUSTRIES (U.S. CLS. 1, 5, 6, 10, 26 AND 46).

FIRST USE 6-1-1994; IN COMMERCE 6-1-1994.  
REBECCA SMITH, EXAMINING ATTORNEY

**CLASS 1—(Continued).**

SN 85-120,876. ARR-MAZ PRODUCTS, L.P., MULBERRY, FL. FILED 9-1-2010.

# CATAMINE

THE MARK CONSISTS OF STANDARD CHARACTERS WITHOUT CLAIM TO ANY PARTICULAR FONT, STYLE, SIZE, OR COLOR.

FOR ASPHALT ADDITIVES AND PAVING PRODUCTS, NAMELY, EMULSIFIERS FOR AGGREGATES WITH PARTICULAR APPLICATION IN RESPECT OF ASPHALT ROAD PAVING APPLICATIONS (U.S. CLS. 1, 5, 6, 10, 26 AND 46).

FIRST USE 7-1-1995; IN COMMERCE 7-1-1995.  
REBECCA SMITH, EXAMINING ATTORNEY

SN 85-123,754. WINFIELD SOLUTIONS, LLC, SHOREVIEW, MN. FILED 9-7-2010.

# FOLIAR TECH

THE MARK CONSISTS OF STANDARD CHARACTERS WITHOUT CLAIM TO ANY PARTICULAR FONT, STYLE, SIZE, OR COLOR.

NO CLAIM IS MADE TO THE EXCLUSIVE RIGHT TO USE "FOLIAR", APART FROM THE MARK AS SHOWN.

FOR CHEMICAL PREPARATIONS FOR USE IN AGRICULTURE, NAMELY, MICRONUTRIENT CHEMICAL PREPARATIONS FOR THE TREATMENT OF SEEDS (U.S. CLS. 1, 5, 6, 10, 26 AND 46).

SANJEEV VOHRA, EXAMINING ATTORNEY

SN 85-141,390. SUN GRO HORTICULTURE CANADA LTD., SEBA BEACH, ONTARIO, CANADA, FILED 9-29-2010.

# SUNSHINE GARDEN CLUB

THE MARK CONSISTS OF STANDARD CHARACTERS WITHOUT CLAIM TO ANY PARTICULAR FONT, STYLE, SIZE, OR COLOR.

OWNER OF U.S. REG. NOS. 802,028, 2,916,426 AND 3,533,056.

NO CLAIM IS MADE TO THE EXCLUSIVE RIGHT TO USE "GARDEN", APART FROM THE MARK AS SHOWN.

FOR POTTING MIX; PLANTING MIX; GROWING MIX ALL FOR HORTICULTURAL USE; POTTING AND PLANTING SOIL MIXES COMPRISED OF ORGANIC MATERIALS AND CONTAINING FERTILIZER ALL FOR HORTICULTURAL USE (U.S. CLS. 1, 5, 6, 10, 26 AND 46).

FIRST USE 10-27-1998; IN COMMERCE 10-27-1998.  
SEAN CROWLEY, EXAMINING ATTORNEY

**CLASS 1—(Continued).**

SN 85-142,034. MACFARLANE, CAMERON, BERKELEY, CA. FILED 9-30-2010.



NO CLAIM IS MADE TO THE EXCLUSIVE RIGHT TO USE "PLANT PLUGS", APART FROM THE MARK AS SHOWN.

THE MARK CONSISTS OF THE WORDS "PLANT PLUGS" IN STYLIZED TEXT WITH THE LETTER "G" IN "PLUG" ILLUSTRATED TO RESEMBLE AN ELECTRICAL PLUG AND THE "T" IN PLANT HAS A PLANT GROWING OUT OF THE TOP OF THE "T".

FOR STABILIZED PLANT GROWTH MEDIA (U.S. CLS. 1, 5, 6, 10, 26 AND 46).

LAKEISHA LEWIS, EXAMINING ATTORNEY

SN 85-149,383. QUILLIN, DAVID, DBA EVERWOOD FARM, SALEM (BROOKS), OR. FILED 10-11-2010.

## Everwood Farm

THE MARK CONSISTS OF STANDARD CHARACTERS WITHOUT CLAIM TO ANY PARTICULAR FONT, STYLE, SIZE, OR COLOR.

NO CLAIM IS MADE TO THE EXCLUSIVE RIGHT TO USE "FARM", APART FROM THE MARK AS SHOWN.

FOR FERTILIZERS FOR AGRICULTURAL USE; FERTILIZERS FOR DOMESTIC USE; NATURAL FERTILIZERS; NUTRITIVE ADDITIVE TO ENHANCE THE BIOLOGICAL ACTIVITY OF WATER, SOIL, SEEDS AND PLANTS FOR PURPOSES OF FERTILIZATION AND BIOREMEDIATION OF POLLUTANTS (U.S. CLS. 1, 5, 6, 10, 26 AND 46).

FIRST USE 4-0-1986; IN COMMERCE 2-0-2005.

SANJEEV VOHRA, EXAMINING ATTORNEY

**CLASS 1—(Continued).**

SN 85-150,883. KENTUCKY-TENNESSEE CLAY COMPANY, ROSWELL, GA. FILED 10-12-2010.

## Aurora

OWNER OF U.S. REG. NO. 3,843,094.

THE MARK CONSISTS OF THE WORD "AURORA" IN A STYLIZED FORM WITH A WAVE LINE EMANATING FROM THE FIRST LETTER "A" AND CONTINUING UNDER THE ENTIRE WORD.

FOR CALCINED KAOLIN FOR INDUSTRIAL PURPOSES (U.S. CLS. 1, 5, 6, 10, 26 AND 46).

WILLIAM P. SHANAHAN, EXAMINING ATTORNEY

SN 85-153,370. PARKER INTANGIBLES LLC, CLEVELAND, OH. FILED 10-15-2010.

## DURACLEAN

THE MARK CONSISTS OF STANDARD CHARACTERS WITHOUT CLAIM TO ANY PARTICULAR FONT, STYLE, SIZE, OR COLOR.

FOR HYDRAULIC FLUID (U.S. CLS. 1, 5, 6, 10, 26 AND 46).

FIRST USE 10-1-2010; IN COMMERCE 10-1-2010.

ROSELLE HERRERA, EXAMINING ATTORNEY

SN 85-159,623. LESAFFRE YEAST CORPORATION, MILWAUKEE, WI. FILED 10-22-2010.

## RED-ZYME

THE MARK CONSISTS OF STANDARD CHARACTERS WITHOUT CLAIM TO ANY PARTICULAR FONT, STYLE, SIZE, OR COLOR.

FOR ENZYMES FOR THE BREWING INDUSTRY (U.S. CLS. 1, 5, 6, 10, 26 AND 46).

SUSAN STIGLITZ, EXAMINING ATTORNEY

**CLASS 1—(Continued).**

SN 85-167,039. SOCIETE D'EXPLOITATION POUR LES PRODUITS CHIMIQUES SEPPIC, PARIS, FRANCE, FILED 11-2-2010.

**LIPACIDE**

THE MARK CONSISTS OF STANDARD CHARACTERS WITHOUT CLAIM TO ANY PARTICULAR FONT, STYLE, SIZE, OR COLOR.  
FOR CHEMICAL PRODUCTS, NAMELY, LIPOAMINOACIDES USED AS A BASE MATERIAL IN COSMETIC PREPARATIONS (U.S. CLS. 1, 5, 6, 10, 26 AND 46).  
FIRST USE 1-1-1994; IN COMMERCE 1-1-1994.  
KELLY CHOE, EXAMINING ATTORNEY

**CLASS 1—(Continued).**

SN 85-176,665. TAO CERAMICS LTD., LOS ANGELES, CA. FILED 11-15-2010.

**TAO**

THE MARK CONSISTS OF STANDARD CHARACTERS WITHOUT CLAIM TO ANY PARTICULAR FONT, STYLE, SIZE, OR COLOR.  
FOR PROPPANT FOR USE IN OIL WELL AND GAS WELL HYDRAULIC FRACTURING OPERATIONS (U.S. CLS. 1, 5, 6, 10, 26 AND 46).  
DEIRDRE ROBERTSON, EXAMINING ATTORNEY

SN 85-173,842. ANDERSON & VREELAND, INC., BRYAN, OH. FILED 11-10-2010.

**AVantage**

THE MARK CONSISTS OF THE UPPERCASE LETTERS "AV" FOLLOWED BY THE LOWERCASE LETTERS "ANTAGE".  
FOR LIQUID PHOTOPOLYMER USED TO MAKE FLEXOGRAPHIC PRINTING PLATES AND RUBBER STAMPS (U.S. CLS. 1, 5, 6, 10, 26 AND 46).  
FIRST USE 4-1-2010; IN COMMERCE 10-1-2010.  
DORITT L. CARROLL, EXAMINING ATTORNEY

SN 85-176,671. TAO CERAMICS LTD., LOS ANGELES, CA. FILED 11-15-2010.

**TAOlite**

THE MARK CONSISTS OF STANDARD CHARACTERS WITHOUT CLAIM TO ANY PARTICULAR FONT, STYLE, SIZE, OR COLOR.  
FOR LIGHT WEIGHT CERAMIC PROPPANTS USED IN THE OIL AND GAS INDUSTRY (U.S. CLS. 1, 5, 6, 10, 26 AND 46).  
DEIRDRE ROBERTSON, EXAMINING ATTORNEY

SN 85-174,124. SWIFT BIOSCIENCES, INC., ANN ARBOR, MI. FILED 11-10-2010.

**MIGHTY PRIMER**

THE MARK CONSISTS OF STANDARD CHARACTERS WITHOUT CLAIM TO ANY PARTICULAR FONT, STYLE, SIZE, OR COLOR.  
FOR DIAGNOSTIC REAGENTS FOR CLINICAL OR MEDICAL LABORATORY USE; DIAGNOSTIC REAGENTS FOR IN VITRO USE IN BIOCHEMISTRY, CLINICAL CHEMISTRY AND MICROBIOLOGY; DIAGNOSTIC REAGENTS FOR SCIENTIFIC OR RESEARCH USE (U.S. CLS. 1, 5, 6, 10, 26 AND 46).  
RONALD DELGIZZI, EXAMINING ATTORNEY

SN 85-176,674. TAO CERAMICS LTD., LOS ANGELES, CA. FILED 11-15-2010.

**TAOisp**

THE MARK CONSISTS OF STANDARD CHARACTERS WITHOUT CLAIM TO ANY PARTICULAR FONT, STYLE, SIZE, OR COLOR.  
FOR INTERMEDIATE STRENGTH PROPPANTS USED IN THE OIL AND GAS INDUSTRY (U.S. CLS. 1, 5, 6, 10, 26 AND 46).  
DEIRDRE ROBERTSON, EXAMINING ATTORNEY

**CLASS 1—(Continued).**

SN 85-176,679. TAO CERAMICS LTD., LOS ANGELES, CA. FILED 11-15-2010.

# TAOhsp

THE MARK CONSISTS OF STANDARD CHARACTERS WITHOUT CLAIM TO ANY PARTICULAR FONT, STYLE, SIZE, OR COLOR.

FOR HIGH STRENGTH PROPPANTS USED IN THE OIL AND GAS INDUSTRY (U.S. CLS. 1, 5, 6, 10, 26 AND 46).

DEIRDRE ROBERTSON, EXAMINING ATTORNEY

**CLASS 1—(Continued).**

SN 85-178,092. SEED DYNAMICS INCORPORATED, SALINAS, CA. FILED 11-16-2010.

# AIR MAXX

THE MARK CONSISTS OF STANDARD CHARACTERS WITHOUT CLAIM TO ANY PARTICULAR FONT, STYLE, SIZE, OR COLOR.

FOR CHEMICAL PREPARATIONS FOR USE IN AGRICULTURE, HORTICULTURE AND FORESTRY, NAMELY, CHEMICAL PREPARATIONS FOR THE TREATMENT OF SEEDS (U.S. CLS. 1, 5, 6, 10, 26 AND 46).

FIRST USE 1-15-2003; IN COMMERCE 1-15-2003.

KAPIL BHANOT, EXAMINING ATTORNEY

SN 85-176,682. TAO CERAMICS LTD., LOS ANGELES, CA. FILED 11-15-2010.

# TAOrc

THE MARK CONSISTS OF STANDARD CHARACTERS WITHOUT CLAIM TO ANY PARTICULAR FONT, STYLE, SIZE, OR COLOR.

FOR RESIN COATED PROPPANTS USED IN THE OIL AND GAS INDUSTRY (U.S. CLS. 1, 5, 6, 10, 26 AND 46).

DEIRDRE ROBERTSON, EXAMINING ATTORNEY

SN 85-178,287. FRONTIER SCIENTIFIC, INC., LOGAN, UT. FILED 11-16-2010.

# AQUAFRIN

THE MARK CONSISTS OF STANDARD CHARACTERS WITHOUT CLAIM TO ANY PARTICULAR FONT, STYLE, SIZE, OR COLOR.

FOR CHEMICALS FOR USE IN AQUACULTURE; CHEMICALS FOR USE IN AQUARIUMS; CHEMICALS FOR USE IN PURIFICATION OF WATER (U.S. CLS. 1, 5, 6, 10, 26 AND 46).

LINDA ESTRADA, EXAMINING ATTORNEY

SN 85-177,994. THE DOW CHEMICAL COMPANY, MIDLAND, MI. FILED 11-16-2010.

# BLACKBIRD

THE MARK CONSISTS OF STANDARD CHARACTERS WITHOUT CLAIM TO ANY PARTICULAR FONT, STYLE, SIZE, OR COLOR.

FOR CHEMICALS FOR USE IN THE MANUFACTURE OF PRINTED CIRCUIT BOARDS, SEMICONDUCTOR PACKAGES, ELECTRONIC COMPONENTS; LITHOGRAPHIC CHEMICALS (U.S. CLS. 1, 5, 6, 10, 26 AND 46).

JAY BESCH, EXAMINING ATTORNEY

SN 85-179,285. MDSOLARSCIENCES CORPORATION, NORWALK, CT. FILED 11-17-2010.

# SolSciX

THE MARK CONSISTS OF STANDARD CHARACTERS WITHOUT CLAIM TO ANY PARTICULAR FONT, STYLE, SIZE, OR COLOR.

FOR CHEMICAL FORMULATIONS FOR USE AS A STABILIZER FOR USE IN SUN PROTECTION PREPARATIONS AND PRODUCTS (U.S. CLS. 1, 5, 6, 10, 26 AND 46).

FIRST USE 3-4-2010; IN COMMERCE 3-4-2010.

DARRYL SPRUILL, EXAMINING ATTORNEY

**CLASS 1—(Continued).**

SN 85-179,760. SOLOHILL ENGINEERING, INC., ANN ARBOR, MI. FILED 11-18-2010.

# SOLOHILL

THE MARK CONSISTS OF STANDARD CHARACTERS WITHOUT CLAIM TO ANY PARTICULAR FONT, STYLE, SIZE, OR COLOR.

FOR MICROCARRIER BEADS FOR USE IN MANUFACTURING, LABORATORY USE AND RESEARCH USE (U.S. CLS. 1, 5, 6, 10, 26 AND 46).

FIRST USE 2-1-1985; IN COMMERCE 2-1-1985.

PAUL F. GAST, EXAMINING ATTORNEY

**CLASS 1—(Continued).**

SN 85-193,801. THE DOW CHEMICAL COMPANY, MIDLAND, MI. FILED 12-9-2010.

# BETAFORCE

THE MARK CONSISTS OF STANDARD CHARACTERS WITHOUT CLAIM TO ANY PARTICULAR FONT, STYLE, SIZE, OR COLOR.

OWNER OF U.S. REG. NOS. 2,500,537, 3,771,503 AND OTHERS.

FOR CHEMICALS USED IN INDUSTRY, NAMELY CHEMICAL SEALANTS AND ADHESIVES FOR USE IN THE MANUFACTURE AND REPAIR OF MOTORIZED VEHICLES (U.S. CLS. 1, 5, 6, 10, 26 AND 46).

JAY BESCH, EXAMINING ATTORNEY

SN 85-181,220. UNITED LABORATORIES, INC., ST. CHARLES, IL. FILED 11-19-2010.

# BIO-RENETICS

THE MARK CONSISTS OF STANDARD CHARACTERS WITHOUT CLAIM TO ANY PARTICULAR FONT, STYLE, SIZE, OR COLOR.

FOR CHEMICALS USED IN INDUSTRY, NAMELY, MULTI-PURPOSE SOLVENTS FOR INDUSTRIAL, AGRICULTURAL AND COMMERCIAL USE; CHEMICAL SOLVENTS USED IN THE MANUFACTURE OF CLEANING AND CONTAMINANT REMOVERS FOR INDUSTRIAL, AGRICULTURAL AND COMMERCIAL USE; CHEMICALS FOR USE IN THE DECONTAMINATION OF POLLUTED SITES; WASTE WATER TREATMENT CHEMICALS FOR INDUSTRIAL USE; CHEMICAL PREPARATIONS FOR CLEANING PURPOSES IN THE FOOD AND FOOD PROCESSING INDUSTRIES; AND CHEMICALS AND SOLVENTS FOR USE IN THE MANUFACTURE OF INSECTICIDES (U.S. CLS. 1, 5, 6, 10, 26 AND 46).

TARAH HARDY, EXAMINING ATTORNEY

SN 85-209,720. THE DOW CHEMICAL COMPANY, MIDLAND, MI. FILED 1-4-2011.

# EVOQUE

THE MARK CONSISTS OF STANDARD CHARACTERS WITHOUT CLAIM TO ANY PARTICULAR FONT, STYLE, SIZE, OR COLOR.

FOR CHEMICALS FOR USE IN THE MANUFACTURE OF PAINTS AND COATINGS (U.S. CLS. 1, 5, 6, 10, 26 AND 46).

JAY BESCH, EXAMINING ATTORNEY

SN 85-191,173. GREEN FUTURE SOIL PRODUCTS, EUREKA, CA. FILED 12-6-2010.

# Lurk Turf

THE MARK CONSISTS OF STANDARD CHARACTERS WITHOUT CLAIM TO ANY PARTICULAR FONT, STYLE, SIZE, OR COLOR.

NO CLAIM IS MADE TO THE EXCLUSIVE RIGHT TO USE "TURF", APART FROM THE MARK AS SHOWN.

FOR POTTING SOIL (U.S. CLS. 1, 5, 6, 10, 26 AND 46). FIRST USE 4-1-2010; IN COMMERCE 4-1-2010.

BRIDGETT SMITH, EXAMINING ATTORNEY

SN 85-218,373. SWIFT BIOSCIENCES, INC., ANN ARBOR, MI. FILED 1-14-2011.

# myT

THE MARK CONSISTS OF STANDARD CHARACTERS WITHOUT CLAIM TO ANY PARTICULAR FONT, STYLE, SIZE, OR COLOR.

FOR DIAGNOSTIC REAGENTS FOR CLINICAL OR MEDICAL LABORATORY USE; DIAGNOSTIC REAGENTS FOR IN VITRO USE IN BIOCHEMISTRY, CLINICAL CHEMISTRY AND MICROBIOLOGY; DIAGNOSTIC REAGENTS FOR SCIENTIFIC OR RESEARCH USE (U.S. CLS. 1, 5, 6, 10, 26 AND 46).

RONALD DELGIZZI, EXAMINING ATTORNEY

**CLASS 2—PAINTS**

SN 77-617,712. BOS HOLDINGS INC., STRATHROY, CANADA, FILED 11-19-2008.

# ECOSTAIN

THE MARK CONSISTS OF STANDARD CHARACTERS WITHOUT CLAIM TO ANY PARTICULAR FONT, STYLE, SIZE, OR COLOR.

PRIORITY CLAIMED UNDER SEC. 44(D) ON CANADA APPLICATION NO. 1416651, FILED 10-31-2008, REG. NO. TMA789870, DATED 2-7-2011, EXPIRES 2-7-2026.

FOR EXTERIOR WOOD STAIN (U.S. CLS. 6, 11 AND 16).

TARAH HARDY, EXAMINING ATTORNEY

**CLASS 2—(Continued).**

SN 85-150,081. CARDINAL INDUSTRIAL FINISHES, SOUTH EL MONTE, CA. FILED 10-11-2010.

# Luthierthane

THE MARK CONSISTS OF STANDARD CHARACTERS WITHOUT CLAIM TO ANY PARTICULAR FONT, STYLE, SIZE, OR COLOR.

FOR CLEAR AND PIGMENTED COATINGS USED IN THE NATURE OF PAINT; COATING COMPOSITIONS IN THE NATURE OF PAINT FOR INDUSTRIAL APPLICATIONS; COATING PREPARATIONS HAVING WATER REPELLENT PROPERTIES; COATINGS FOR WOOD AS PAINTS; COATINGS IN THE NATURE OF INDUSTRIAL SEALANTS FOR WATERPROOFING AND SURFACE HARDENING; COATINGS IN THE NATURE OF PAINTS AND CLEAR COATINGS FOR USE IN ADDING COLORS AND PROTECTING VARIOUS SURFACES FOR GUITARS AND OTHER MUSICAL INSTRUMENTS, AND HOUSEHOLD AND INDUSTRIAL GOODS; COATINGS USED FOR FURNITURE FINISHING; COATINGS, NAMELY, STAINS AND CLEAR FINISHES FOR EXTERIOR AND INTERIOR USE ON A VARIETY OF SUBSTRATES; COLOR PIGMENTS; COLORANT DISPERSIONS FOR USE IN SURFACE COATING COMPOSITIONS; COLORANTS; COLORANTS FOR USE IN THE MANUFACTURE OF PAINT; COLORANTS FOR USE IN THE MANUFACTURE OF PLASTIC MOLDING COMPOUNDS; COLORANTS FOR USE IN THE MANUFACTURE OF GUITARS AND OTHER MUSICAL INSTRUMENTS, AND HOUSEHOLD AND INDUSTRIAL GOODS; COLORANTS, PAINTS AND DYES FOR GENERAL INDUSTRIAL USE; COLOURANTS; CORROSION INHIBITANTS IN THE NATURE OF A COATING; DECORATIVE SPRAY COATING; DIRECT DYES; DYES FOR WOOD; ENAMEL PAINTS; FLUORESCENT PAINTS; GLAZES; GOUACHES IN THE NATURE OF OPAQUE COLOR PIGMENTS; LACQUERS; LACQUERS IN THE NATURE OF A COATING; MIXED PAINTS; PAINT FOR INDUSTRIAL EQUIPMENT AND MACHINERY; PAINT FOR USE IN THE MANUFACTURE OF FURNITURE; PAINT FOR USE IN THE MANUFACTURE OF GUITARS AND OTHER MUSICAL INSTRUMENTS, AND HOUSEHOLD AND INDUSTRIAL GOODS; PAINTS; PAINTS AND LACQUERS; PAINTS, LACQUERS, VARNISHES; PIGMENTS; PRIMER; PRIMERS; PRIMERS FOR PREPARING SURFACES TO BE PAINTED; UNDERCOATING FOR SURFACES TO BE PAINTED; VARNISH; VARNISHES; WOOD PRESERVATIVES; WOOD STAINS; WOOD TREATMENT PREPARATIONS FOR PRESERVING (U.S. CLS. 6, 11 AND 16).

KIMBERLY FRYE, EXAMINING ATTORNEY

SN 85-025,386. SWIMC, INC., NEWARK, DE. FILED 4-28-2010.



OWNER OF U.S. REG. NOS. 387,689, 2,299,894 AND OTHERS.

THE MARK CONSISTS OF THE WORDS "DUPLI-COLOR" INSIDE A SHIELD DESIGN.

FOR PAINTS (U.S. CLS. 6, 11 AND 16).

FIRST USE 3-19-2010; IN COMMERCE 3-19-2010.

ROBERT STRUCK, EXAMINING ATTORNEY

**CLASS 2—(Continued).**

SN 85-155,264. CARDINAL INDUSTRIAL FINISHES, SOUTH EL MONTE, CA. FILED 10-18-2010.

# Lutherthane

THE MARK CONSISTS OF STANDARD CHARACTERS WITHOUT CLAIM TO ANY PARTICULAR FONT, STYLE, SIZE, OR COLOR.

FOR CLEAR AND PIGMENTED COATINGS USED IN THE NATURE OF PAINT; COATING COMPOSITIONS IN THE NATURE OF PAINT FOR INDUSTRIAL APPLICATIONS; COATING PREPARATIONS HAVING WATER REPELLENT PROPERTIES; COATINGS FOR WOOD AS PAINTS; COATINGS IN THE NATURE OF INDUSTRIAL SEALANTS FOR WATERPROOFING AND SURFACE HARDENING; COATINGS IN THE NATURE OF PAINTS AND CLEAR COATINGS FOR USE IN ADDING OR APPLYING COLORS AND PROTECTING VARIOUS SURFACES FOR GUITARS AND OTHER MUSICAL INSTRUMENT, AND VARIOUS HOUSEHOLD, COMMERCIAL AND INDUSTRIAL GOODS; COATINGS USED FOR FURNITURE FINISHING; COATINGS, NAMELY, STAINS AND CLEAR FINISHES FOR EXTERIOR AND INTERIOR USE ON A VARIETY OF SUBSTRATES; COLOR PIGMENTS; COLORANT DISPERSIONS FOR USE IN SURFACE COATING COMPOSITIONS; COLORANTS; COLORANTS FOR USE IN THE MANUFACTURE OF PAINT; COLORANTS FOR USE IN THE MANUFACTURE OF PLASTIC MOLDING COMPOUNDS; COLORANTS FOR USE IN THE MANUFACTURE OF GUITARS AND OTHER MUSICAL INSTRUMENTS, AND VARIOUS HOUSEHOLD, COMMERCIAL AND INDUSTRIAL GOODS; COLOURANTS; CORROSION INHIBITANTS IN THE NATURE OF A COATING; DECORATIVE SPRAY COATING; DIRECT DYES; DYES FOR WOOD; ENAMEL PAINTS; FLUORESCENT PAINTS; GLAZES; GOUACHES IN THE NATURE OF OPAQUE COLOR PIGMENTS; LACQUERS; LACQUERS IN THE NATURE OF A COATING; MIXED PAINTS; PAINT FOR INDUSTRIAL EQUIPMENT AND MACHINERY; PAINT FOR USE IN THE MANUFACTURE OF FURNITURE; PAINT FOR USE IN THE MANUFACTURE OF GUITARS AND OTHER MUSICAL INSTRUMENT, AND VARIOUS HOUSEHOLD, COMMERCIAL AND INDUSTRIAL GOODS; PAINTS; PAINTS AND LACQUERS; PAINTS, LACQUERS, VARNISHES; PIGMENTS; PRIMER; PRIMERS; PRIMERS FOR PREPARING SURFACES TO BE PAINTED; UNDERCOATING FOR SURFACES TO BE PAINTED; VARNISH; VARNISHES; WOOD PRESERVATIVES; WOOD STAINS; WOOD TREATMENT PREPARATIONS FOR PRESERVING (U.S. CLS. 6, 11 AND 16).

KIMBERLY FRYE, EXAMINING ATTORNEY

**CLASS 2—(Continued).**

SN 85-156,319. RCS SUPPLYS, BROOKLYN, NY. FILED 10-19-2010.

# Grizim Supply

THE MARK CONSISTS OF STANDARD CHARACTERS WITHOUT CLAIM TO ANY PARTICULAR FONT, STYLE, SIZE, OR COLOR.

NO CLAIM IS MADE TO THE EXCLUSIVE RIGHT TO USE "SUPPLY". APART FROM THE MARK AS SHOWN.

THE WORDING "GRIZIM" HAS NO MEANING IN A FOREIGN LANGUAGE.

FOR TONERS (U.S. CLS. 6, 11 AND 16).

FIRST USE 9-1-2010; IN COMMERCE 9-1-2010.

NANCY CLARKE, EXAMINING ATTORNEY

SN 85-158,519. GUPTA, LAXMI C, LOS ALAMITOS, CA. FILED 10-21-2010.

# U-TUFF

THE MARK CONSISTS OF STANDARD CHARACTERS WITHOUT CLAIM TO ANY PARTICULAR FONT, STYLE, SIZE, OR COLOR.

OWNER OF U.S. REG. NOS. 3,198,897 AND 3,201,920.

FOR CLEAR AND PIGMENTED COATINGS USED IN THE NATURE OF PAINT (U.S. CLS. 6, 11 AND 16).

FIRST USE 10-11-2010; IN COMMERCE 10-18-2010.

ROBIN MITTLER, EXAMINING ATTORNEY

SN 85-177,454. MUELLER INTERNATIONAL, INC., ATLANTA, GA. FILED 11-16-2010.

# SG-14

THE MARK CONSISTS OF STANDARD CHARACTERS WITHOUT CLAIM TO ANY PARTICULAR FONT, STYLE, SIZE, OR COLOR.

FOR CORROSION INHIBITANTS IN THE NATURE OF A COATING FOR LINING BOTH DUCTILE IRON AND STEEL PIPE AND FITTINGS (U.S. CLS. 6, 11 AND 16).

FIRST USE 2-0-1983; IN COMMERCE 2-0-1983.

TOBY BULLOFF, EXAMINING ATTORNEY

**CLASS 2—(Continued).**

SN 85-194,195. NORTHERN TECHNOLOGIES INTERNATIONAL CORPORATION, BEACHWOOD, OH. FILED 12-9-2010.

# ZERION

THE MARK CONSISTS OF STANDARD CHARACTERS WITHOUT CLAIM TO ANY PARTICULAR FONT, STYLE, SIZE, OR COLOR.

FOR CORROSION INHIBITANTS IN THE NATURE OF A COATING (U.S. CLS. 6, 11 AND 16).

DAWN FELDMAN, EXAMINING ATTORNEY

SN 85-221,597. DUNCAN ENTERPRISES, DBA ILOVE-TOCREATE, FRESNO, CA. FILED 1-19-2011.

# TULIP VELVETEEN

THE MARK CONSISTS OF STANDARD CHARACTERS WITHOUT CLAIM TO ANY PARTICULAR FONT, STYLE, SIZE, OR COLOR.

OWNER OF U.S. REG. NOS. 2,458,179, 2,653,661 AND OTHERS.

NO CLAIM IS MADE TO THE EXCLUSIVE RIGHT TO USE "VELVETEEN", APART FROM THE MARK AS SHOWN.

FOR PAINT FOR FABRICS; PAINT FOR ART AND CRAFTS (U.S. CLS. 6, 11 AND 16).

FIRST USE 1-31-1990; IN COMMERCE 1-31-1990.

STEVEN PEREZ, EXAMINING ATTORNEY

SN 85-221,618. DUNCAN ENTERPRISES, DBA ILOVE-TOCREATE, FRESNO, CA. FILED 1-19-2011.

# TULIP NEON

THE MARK CONSISTS OF STANDARD CHARACTERS WITHOUT CLAIM TO ANY PARTICULAR FONT, STYLE, SIZE, OR COLOR.

OWNER OF U.S. REG. NOS. 2,458,179, 2,653,661 AND OTHERS.

NO CLAIM IS MADE TO THE EXCLUSIVE RIGHT TO USE "NEON", APART FROM THE MARK AS SHOWN.

FOR PAINT FOR FABRICS; PAINT FOR ART AND CRAFTS (U.S. CLS. 6, 11 AND 16).

FIRST USE 1-31-1990; IN COMMERCE 1-31-1990.

STEVEN PEREZ, EXAMINING ATTORNEY

**CLASS 3—COSMETICS AND CLEANING PREPARATIONS**

SN 76-703,697. SOCIETE PARISIENNE DE PARFUMS ET COSMETIQUES, PARIS, FRANCE, FILED 7-8-2010.

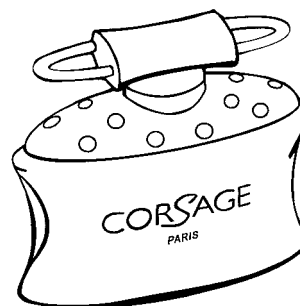

OWNER OF U.S. REG. NO. 3,083,335.

NO CLAIM IS MADE TO THE EXCLUSIVE RIGHT TO USE "PARIS", APART FROM THE MARK AS SHOWN.

THE MARK CONSISTS OF THE TERMS "CORSAGE" AND "PARIS" AND THE DESIGN OF A THREE DIMENSIONAL CONFIGURATION OF A PERFUME BOTTLE AND CAP THEREFORE. THE BOTTLE IS GENERALLY SHORT AND BROAD WITH FLARED SHOULDERS AND BASE. THE BASE OF THE CAP HAS MULTIPLE HOLES AND THE TOP OF THE CAP HAS HORIZONTAL ELLIPTICAL EXTENSIONS ON BOTH SIDES.

SEC. 2(F).

FOR PERFUMES AND COLOGNES (U.S. CLS. 1, 4, 6, 50, 51 AND 52).

FIRST USE 1-0-2005; IN COMMERCE 2-0-2005.

PRISCILLA MILTON, EXAMINING ATTORNEY

SN 76-704,391. SNYDER, GRIFF, WESTLAKE VILLAGE, CA. AND SNYDER, SARI, WESTLAKE VILLAGE, CA. AND MOSS, SUZANNE, WESTLAKE VILLAGE, CA. FILED 9-7-2010.



THE LITERAL ELEMENT OF THE MARK CONSISTS OF "INNOUVELLE". THE MARK CONSISTS OF THE WORDING "INNOUVELLE" SUPERIMPOSED OVER A MISCELLANEOUS DESIGN.

THE TERM "INNOUVELLE" HAS NO MEANING IN A FOREIGN LANGUAGE.

FOR NON-MEDICATED SHAMPOOS AND SKIN CARE PRODUCTS, NAMELY, PREPARATIONS IN CREAM AND LIQUID FORM (U.S. CLS. 1, 4, 6, 50, 51 AND 52).

FIRST USE 1-1-2002; IN COMMERCE 1-1-2002.

LEIGH CAROLINE CASE, EXAMINING ATTORNEY



**CLASS 3—(Continued).**

SN 76-704,504. ENRICH BIOTECH GLOBAL LIMITED, WILMINGTON, DE. FILED 9-15-2010.

THE MARK CONSISTS OF THE STYLIZED LETTERS "ERH", THE LETTER "R" IS INCOMPLETE AND MERGED WITH THE LETTER "E".

FOR BEAUTY MASKS; BEAUTY SERUMS; COSMETICS AND COSMETIC PREPARATIONS; COSMETIC CREAMS FOR SKIN CARE; FACE AND BODY BEAUTY CREAMS; FACIAL CLEANSING MILK; FOUNDATION MAKE-UP; FOUNDATIONS; HAIR SHampoos AND CONDITIONERS; LIPSTICKS; MAKE-UP REMOVER; MOUSSE FOR HAIR AND SKIN; NON-MEDICATED SKIN CARE PREPARATIONS; SKIN CARE PRODUCTS, NAMELY, NON-MEDICATED SKIN SERUM; SKIN CLEANSING CREAM; SKIN CLEANSING LOTION; SKIN TONERS; SUNSCREEN CREAM; WATERPROOF SUNSCREEN (U.S. CLS. 1, 4, 6, 50, 51 AND 52).

FIRST USE 1-10-2009; IN COMMERCE 1-10-2009.  
JESSICA FATHY, EXAMINING ATTORNEY

SN 77-762,313. BATH & BODY WORKS BRAND MANAGEMENT, INC., REYNOLDSBURG, OH. FILED 6-17-2009.

THE MARK CONSISTS OF STANDARD CHARACTERS WITHOUT CLAIM TO ANY PARTICULAR FONT, STYLE, SIZE, OR COLOR.

FOR PERSONAL CARE PRODUCTS, NAMELY, 3-IN-1 HAIR CONDITIONERS, 3-IN-1 HAIR SHampoos, AFTER SUN CREAMS, AFTER-SHAVE, AFTER-SHAVE BALMS, AFTER-SHAVE CREAMS, AFTER-SHAVE EMULSIONS, AFTER-SHAVE GEL, AFTER-SHAVE LOTIONS, AFTER-SUN GELS, AFTER-SUN LOTIONS, AFTER-SUN OILS, AGE RETARDANT GEL, AGE RETARDANT LOTION, AGE SPOT REDUCING CREAMS, ANTI-AGING CREAM, ANTI-FRECKLE CREAMS, ANTI-PERSPIRANTS, ANTI-WRINKLE CREAMS, ANTI-BACTERIAL SKIN SOAPS, ANTIPERSPIRANTS FOR PERSONAL USE, AROMATHERAPY CREAMS, AROMATHERAPY LOTIONS, AROMATHERAPY OILS, AS-TRINGENTS FOR COSMETIC PURPOSES, BATH BEADS, BATH CRYSTALS, BATH FOAMS, BATH GELS, BATH LOTION, BATH MILKS, BATH OILS FOR COSMETIC PURPOSES, BATH PEARLS, BATH POWDER, BATH SALTS, BATH SOAPS IN LIQUID, SOLID OR GEL FORM, BATHING LOTIONS, BAY RUMS, BEAUTY CREAMS FOR BODY CARE, BEAUTY GELS, BEAUTY LOTIONS, BEAUTY MASKS, BEAUTY MILKS, BEAUTY SERUMS, BLUSH, BLUSH PENCILS, BODY AND BEAUTY CARE COSMETICS, BODY CREAM SOAP, BODY CREAMS, BODY EMULSIONS, BODY GLITTER, BODY LOTIONS, BODY MASK CREAM, BODY MASK LOTION, BODY MASK POWDER, BODY MASKS, BODY MILKS, BODY OILS, BODY POWDER, BODY SCRUB, BODY SPRAY USED AS A PERSONAL DEODORANT

**CLASS 3—(Continued).**

AND AS FRAGRANCE, BODY SPRAYS, NAMELY, WATER IN ATOMIZED CONTAINERS USED TO PRODUCE A COOLING EFFECT, BODY WASHES, BUBBLE BATH, CLEANSING CREAMS, COLD CREAMS, COLOGNE, COLOGNE WATER, COMPACTS CONTAINING MAKE-UP, CONCEALERS FOR FACE AND BODY, CONDITIONERS, COSMETIC CREAMS, COSMETIC CREAMS FOR SKIN CARE, COSMETIC FACIAL BLOT-TING PAPERS, COSMETIC MILKS, COSMETIC OILS, COSMETIC PADS, COSMETIC PENCILS, COSMETIC PREPARATIONS AGAINST SUNBURN, COSMETIC PREPARATIONS FOR BODY CARE, COSMETIC PREPARATIONS FOR EYE LASHES, COSMETIC PREPARATIONS FOR SKIN RENEWAL, COSMETIC PRODUCTS IN THE FORM OF AEROSOLS FOR SKIN CARE, COSMETIC ROUGES, COSMETIC SOAPS, COSMETIC SUN-PROTECTING PREPARATIONS, COSMETIC SUN-TANNING PREPARATIONS, COSMETIC SUNTAN LOTIONS, COSMETICS, COSMETICS, NAMELY, COMPACTS, COSMETICS, NAMELY, LIP PRIMER, COSMETICS, NAMELY, LIP REPAIRERS, CREAM SOAPS, CREAMS FOR CELLULITE REDUCTION, CREAMY FACE POWDER, CREAMY FOUNDATION, CREAMY ROUGES, CUTICLE CONDITIONERS, CUTICLE CREAM, CUTICLE REMOVING PREPARATIONS, DEODORANT FOR PERSONAL USE, DEODORANT SOAP, DEODORANTS AND ANTIPERSPIRANTS, DEODORANTS FOR BODY CARE, DEPILATORIES, DEPILATORY CREAMS, DUSTING POWDER, EAU DE PARFUM, EAU DE TOILETTE, EMERY BOARDS, ESSENTIAL OILS FOR PERSONAL USE, EXFOLIANT CREAMS, EXFOLIANTS FOR SKIN, EYE COMPRESSES FOR COSMETIC PURPOSES, EYE CREAM, EYE GELS, EYE LINER, EYE LOTIONS, EYE MAKE-UP, EYE MAKE-UP REMOVER, EYE PENCILS, EYE SHADOWS, EYEBROW COLORS, EYEBROW PENCILS, EYELINER, EYESHADOWS, FACE AND BODY BEAUTY CREAMS, FACE AND BODY CREAMS, FACE AND BODY GLITTER, FACE AND BODY LOTIONS, FACE AND BODY MILK, FACE CREAMS, FACE CREAMS FOR COSMETIC USE, FACE GLITTER, FACE MILK AND LOTIONS, FACE POWDER, FACIAL BEAUTY MASKS, FACIAL CLEANSERS, FACIAL CLEANSING MILK, FACIAL CONCEALER, FACIAL CREAMS, FACIAL EMULSIONS, FACIAL LOTION, FACIAL MAKE-UP, FACIAL MASKS, FACIAL SCRUBS, FACIAL WASHES, FOAM BATH, FOAMS CONTAINING COSMETICS AND SUNSCREENS, FOOT DEODORANT SPRAY, NON-MEDICATED FOOT CREAM, NON-MEDICATED FOOT LOTION, FOOT POWDER, FOUNDATION, FRAGRANCE EMITTING WICKS FOR ROOM FRAGRANCE, FRAGRANCES FOR AUTOMOBILES, FRAGRANCES FOR PERSONAL USE, GEL EYE MASKS, HAIR CARE CREAMS, HAIR CARE KITS COMPRISING NON-MEDICATED HAIR CARE PREPARATIONS, NAMELY, SHAMPOO, CONDITIONER, HAIRSTYLING PREPARATIONS, HAIR CARE LOTIONS, HAIR CARE PREPARATIONS, HAIR CLEANING PREPARATIONS, HAIR CONDITIONERS, HAIR CREAMS, HAIR GELS, HAIR LOTIONS HAIR POMADES, HAIR REMOVING CREAM, HAIR SHAMPOO, HAIR SPRAY, HAIR STYLING PREPARATIONS, HAIR TONICS, HAND CLEANSERS, HAND CLEANING PREPARATIONS, HAND CREAMS, HAND LOTIONS, HAND SOAPS, HAND WASH, INCENSE, LIP BALM, LIP CREAM, LIP GLOSS, LIP GLOSS PALATTE, LIP LINER, LIP POLISHER, LIPSTICK, LIPSTICK HOLDERS, LIPSTICKS, LIQUID BATH SOAPS, LIQUID PERFUMES, LIQUID SOAP, LIQUID SOAPS FOR HANDS, FACE AND BODY, LOOSE FACE POWDER, LOTIONS FOR CELLULITE REDUCTION, LOTIONS FOR FACE AND BODY CARE, LOTIONS FOR STRENGTHENING THE NAILS, LOTIONS FOR FACE AND BODY, MAKE UP REMOVING PREPARATIONS, MAKE-UP FOR THE FACE AND BODY, MAKE-UP KITS COMPRISED OF LIPSTICK, LIP GLOSS, BLUSH AND EYE SHADOW, MAKE-UP PENCILS, MAKE-UP POWDER, MAKE-UP REMOVER, MAKE-UP REMOVING LOTIONS, MAKE-UP REMOVING MILK, GEL, LOTIONS AND CREAMS, MASCARAS, MASSAGE OILS, MEDICATED SOAPS, MINERAL SALT IN THE NATURE OF BATH SALTS NOT FOR MEDICAL PURPOSES, MOISTURIZING CREAMS, MOISTURIZING MILKS, MOUSSE FOR HAIR, MOUTHWASHES, NAIL BUFFING PREPARATIONS, NAIL CARE PREPARATIONS, NAIL CARE PREPARATIONS, NAMELY, NAIL SOFTENERS, NAIL CREAM, NAIL ENAMEL, NAIL POLISH, NAIL POLISH REMOVERS, NIGHT CREAM, NON-MEDICATED ACNE TREATMENT PREPARA-

**CLASS 3—(Continued).**

TIONS, NON-MEDICATED BATH PREPARATIONS, NON-MEDICATED BODY SOAKS, NON-MEDICATED FOOT CREAM, NON-MEDICATED LIP CARE PREPARATIONS, NON-MEDICATED LIP PROTECTOR, NON-MEDICATED MOUTH WASH AND RINSE, NON-MEDICATED OINTMENTS FOR THE PREVENTION AND TREATMENT OF SUNBURN, NON-MEDICATED SCALP TREATMENT CREAM, NON-MEDICATED SKIN CARE PREPARATIONS, NON-MEDICATED SKIN CREAMS, NON-MEDICATED STIMULATING LOTIONS FOR THE SKIN, NON-MEDICATED SUN CARE PREPARATIONS, PARAFFIN WAX FOR COSMETIC PURPOSES, PATCHES CONTAINING SUN SCREEN AND SUN BLOCK FOR USE ON THE SKIN, PENCILS FOR COSMETIC PURPOSES, PERFUME, PERFUME OILS, PERFUMED CREAMS, PERFUMED POWDERS, PERFUMED SOAPS, PERFUMING SACHETS, PERSONAL DEODORANTS, POTPOURRI, PRE-MOISTENED COSMETIC TOWELETTES, PRE-SHAVE CREAMS PRESSED FACE POWDER, ROOM FRAGRANCE REFILLS FOR NON-ELECTRIC ROOM FRAGRANCE DISPENSERS, ROOM FRAGRANCES, ROUGES, SPF SUNBLOCK TOWELETTES, SACHET-LIKE EYE PILLOWS CONTAINING FRAGRANCES, SACHETS SCENTED BODY SPRAY, SCENTED CERAMIC STONES, SCENTED LINEN SPRAYS, SCENTED OILS USED TO PRODUCE AROMAS WHEN HEATED, SCENTED ROOM SPRAYS, SCULPTING GEL, SELF-TANNING PREPARATIONS, SHAMPOO-CONDITIONERS, SHAMPOOS, SHAVING BALM, SHAVING CREAMS, SHAVING FOAMS, SHAVING GELS, SHAVING LOTIONS, SHAVING MOUSSE, SHAVING PREPARATIONS, SHAVING SOAP, SHOWER AND BATH FOAM, SHOWER AND BATH GEL, SHOWER CREAMS, SHOWER GELS, SKIN BRONZER, SKIN BRONZING CREAMS, SKIN CARE PREPARATION, NAMELY, BODY POLISH, SKIN CARE PREPARATIONS, NAMELY, CHEMICAL PEELS FOR SKIN, SKIN CARE PRODUCTS, NAMELY, NON-MEDICATED SKIN SERUM, SKIN CLARIFIERS, SKIN CLEANSERS, SKIN CLEANSING CREAM, SKIN CLEANSING LOTION, SKIN CONDITIONERS, SKIN CREAMS, SKIN CREAMS IN LIQUID AND SOLID FORM, SKIN EMOLLIENTS, SKIN FIRING LOTION, SKIN GELS FOR ACCELERATING, ENHANCING OR EXTENDING TANS, SKIN LIGHTENING CREAMS, SKIN LOTIONS, SKIN MASKS, SKIN MOISTURIZER, SKIN MOISTURIZER MASKS, SKIN SOAP, SKIN TONERS, SOAPS FOR BODY CARE, SOAPS FOR PERSONAL USE, STYLING GELS, STYLING LOTIONS, STYLING MOUSSE, SUN BLOCK, SUN BLOCK PREPARATIONS, SUN CARE LOTIONS, SUN CREAMS, SUN SCREEN, SUN SCREEN PREPARATIONS, SUN TAN LOTION, SUN TAN OIL, SUN-BLOCK LOTIONS, SUNSCREEN CREAMS, SUNTANNING PREPARATIONS, TANNING CREAMS, TOOTH PASTE, TOPICAL SKIN SPRAYS FOR COSMETIC PURPOSES, VANISHING CREAM, WAX FOR REMOVING BODY HAIR, WRINKLE REMOVING SKIN CARE PREPARATIONS, WRINKLE RESISTANT CREAM (U.S. CLS. 1, 4, 6, 50, 51 AND 52).

SEAN CROWLEY, EXAMINING ATTORNEY

SN 77-795,097. CABRERA, JOSE ANTONIO, HOMESTEAD, FL. FILED S.R. 8-2-2009; AM. P.R. 2-28-2011.

## Starfire's Winner Circle

THE MARK CONSISTS OF STANDARD CHARACTERS WITHOUT CLAIM TO ANY PARTICULAR FONT, STYLE, SIZE, OR COLOR.

FOR PET SHAMPOO AND CONDITIONER; PET STAIN REMOVERS (U.S. CLS. 1, 4, 6, 50, 51 AND 52).

TRICIA SONNEBORN, EXAMINING ATTORNEY

**CLASS 3—(Continued).**

SN 77-847,991. COSWAY (M) SDN. BHD., 50200 KUALA LUMPUR, MALAYSIA, FILED 10-13-2009.

OWNER OF MALAYSIA REG. NO. 03015896, DATED 11-24-2003, EXPIRES 11-24-2013.

THE NAME(S), PORTRAIT(S), AND/OR SIGNATURE(S) SHOWN IN THE MARK DOES NOT IDENTIFY A PARTICULAR LIVING INDIVIDUAL.

THE MARK CONSISTS OF THE STYLIZED TERM "LELAN VITAL".

THE WORDING "LELAN VITAL" HAS NO MEANING IN A FOREIGN LANGUAGE.

FOR AROMATICS, NAMELY, PERFUMES; BEAUTY MASK; BLEACHING PREPARATIONS FOR COSMETICS PURPOSES; COSMETICS; CREAMS, NAMELY, COSMETIC CREAMS; DEODORANTS FOR PERSONAL USE; DEPILATORIES; DEPILATORY PREPARATIONS; EXTRACTS OF FLOWERS, NAMELY, PERFUMES; HAIR COLORANTS; HAIR DYES; HAIR LOTIONS; LAVENDER WATER FOR COSMETIC PURPOSES; LIPSTICKS; LOTIONS, NAMELY, BODY LOTIONS, HAND LOTIONS; MAKE UP; MAKE UP REMOVING PREPARATIONS; CLEANSING MILK FOR TOILET PURPOSES; OILS FOR SKIN CARE; PERFUMES AND SCENTS, NAMELY, PERFUMES AND OILS FOR PERFUMES AND SCENTS; COSMETIC PENCILS; BODY TALCUM POWDER; SHAMPOOS; SKIN CARE, NAMELY, NON-MEDICATED SKIN CARE PREPARATIONS; SKIN CREAMS; SOAP; TOILETRIES SLIMMING GELS AND SHOWER SALT IN THE NATURE OF BATH AND SHOWER GELS AND SALTS NOT FOR MEDICAL PURPOSES (U.S. CLS. 1, 4, 6, 50, 51 AND 52).

AMEEN IMAM, EXAMINING ATTORNEY

**CLASS 3—(Continued).**

SN 77-890,490. ARVIZU, JUAN MANUEL RAYAS, ZAPOPAN, JALISCO, MEXICO, FILED 12-10-2009.



OWNER OF MEXICO REG. NO. 955824, DATED 9-28-2006, EXPIRES 12-6-2015.

THE COLOR(S) WHITE, LIGHT BLUE, PURPLE, DARK BLUE, BROWN, BLACK AND TAN IS/ARE CLAIMED AS A FEATURE OF THE MARK.

THE MARK CONSISTS OF THE FOLLOWING: A TAN COLORED WOMAN WEARING A PURPLE SWIMSUIT AND A WHITE AND LIGHT BLUE SCARF. THE WOMAN HAS BROWN HAIR AND BLACK SUNGLASSES. THE COLOR DARK BLUE APPEARS IN THE BACKGROUND. BELOW APPEARS THE WORD "DEMOGRASS" IN BLACK. THE COLOR GRAY IS FOR SHADING PURPOSES ONLY AND IS NOT CLAIMED AS A FEATURE OF THE MARK.

FOR COSMETICS; SOAPS (U.S. CLS. 1, 4, 6, 50, 51 AND 52).

ELIZABETH KAJUBI, EXAMINING ATTORNEY

SN 77-896,828. COMPLEXIONS BY DR. WATTS SKIN CARE AND BEAUTY PRODUCTS, LLC, VINELAND, NJ. FILED 12-18-2009.

FootMedix by Dr. Watts

THE MARK CONSISTS OF STANDARD CHARACTERS WITHOUT CLAIM TO ANY PARTICULAR FONT, STYLE, SIZE, OR COLOR.

THE NAME "DR. WATTS" APPEARING IN THE MARK IDENTIFIES A LIVING INDIVIDUAL WHOSE CONSENT IS OF RECORD.

FOR COSMETIC CREAM FOR FOOT SKIN CARE (U.S. CLS. 1, 4, 6, 50, 51 AND 52).

CHARISMA HAMPTON, EXAMINING ATTORNEY

**CLASS 3—(Continued).**

SN 77-955,488. AUSTRALIAN GOLD, LLC, INDIANAPOLIS, IN. FILED 3-10-2010.

HD MANN

THE MARK CONSISTS OF STANDARD CHARACTERS WITHOUT CLAIM TO ANY PARTICULAR FONT, STYLE, SIZE, OR COLOR.

FOR NON-MEDICATED INDOOR AND OUTDOOR SKIN TANNING PREPARATIONS (U.S. CLS. 1, 4, 6, 50, 51 AND 52).

FIRST USE 11-1-2010; IN COMMERCE 11-1-2010.

TRACY FLETCHER, EXAMINING ATTORNEY

SN 77-956,491. AWESOME PRODUCTS, INC., BUENA PARK, CA. FILED 3-11-2010.

TAD

THE MARK CONSISTS OF STANDARD CHARACTERS WITHOUT CLAIM TO ANY PARTICULAR FONT, STYLE, SIZE, OR COLOR.

FOR LAUNDRY DETERGENT (U.S. CLS. 1, 4, 6, 50, 51 AND 52).

WENDY GOODMAN, EXAMINING ATTORNEY

SN 77-967,125. BOOM LLC, NEW YORK, NY. FILED 3-24-2010.

LASHLIFT

THE MARK CONSISTS OF STANDARD CHARACTERS WITHOUT CLAIM TO ANY PARTICULAR FONT, STYLE, SIZE, OR COLOR.

FOR LASH CONDITIONERS, LASH THICKENERS, LASH LENGTHENERS, MASCARA (U.S. CLS. 1, 4, 6, 50, 51 AND 52).

LANA PHAM, EXAMINING ATTORNEY

**CLASS 3—(Continued).**

SN 77-967,375. MILLENNIUM LAWNS, INC., BEDFORD PARK, IL. FILED 3-24-2010.

**EARTH'S BALANCE**

THE MARK CONSISTS OF STANDARD CHARACTERS WITHOUT CLAIM TO ANY PARTICULAR FONT, STYLE, SIZE, OR COLOR.

FOR PROBIOTIC SOLUTION FOR ELIMINATING ODORS FROM ANIMALS CAUSED BY SKUNK SPRAY (U.S. CLS. 1, 4, 6, 50, 51 AND 52).

FIRST USE 8-14-2000; IN COMMERCE 8-14-2000.  
NICHOLAS COLEMAN, EXAMINING ATTORNEY

SN 78-170,874. TMB ENTERPRISES, LLC, LEXINGTON, KY. FILED 10-3-2002.

**RADIANT GLOW**

FOR SUNLESS TANNING SYSTEMS COMPRISING AN AIR COMPRESSOR A SPRAY NOZZLE AND LIQUID TANNING SOLUTION, PRIMARILY MARKETED TO TANNING SALONS (U.S. CLS. 1, 4, 6, 50, 51 AND 52).

FIRST USE 6-30-2002; IN COMMERCE 6-30-2002.  
CHERYL CLAYTON, EXAMINING ATTORNEY

SN 79-071,792. MILK & CO PROPRIETARY LIMITED, AUSTRALIA, FILED 7-16-2009.



OWNER OF INTERNATIONAL REGISTRATION 1010156 DATED 7-16-2009, EXPIRES 7-16-2019.

NO CLAIM IS MADE TO THE EXCLUSIVE RIGHT TO USE "MILK", APART FROM THE MARK AS SHOWN.

FOR COSMETIC SKINCARE PREPARATIONS; ABRASIVE PREPARATIONS FOR USE ON THE BODY; BABIES' BODY MILKS; BABY BODY MILKS; NON-MEDICATED BODYCARE PREPARATIONS; NON-MEDICATED BODY CREAMS; BODY DEODORANTS; NON-MEDICATED BODY LOTIONS; BODY MILKS; BODY MOISTURISERS; BODY OIL; BODY OIL SPRAY; NON-MEDICATED FACE AND BODY PAINT; BODY POWDER, NOT MEDICATED; BODY SCRUBS; BODY SHAMPOOS; BODY SOAPS; NON-MEDICATED BODY SPRAYS; BODY TALCUM POWDER; CLEANING PREPARATIONS FOR USE ON THE BODY; COSMETIC PREPARATIONS FOR USE ON THE BODY; DEODORANTS FOR THE BODY; DUSTING POWDER FOR THE BODY; GELS FOR USE ON THE BODY; NON-MEDICATED MOISTURISING BODY LOTION; NON-MEDICATED CREAMS FOR THE BODY; NON-MEDICATED GELS FOR THE BODY; NON-MEDICATED PREPARATIONS FOR THE CARE OF THE SKIN, HAIR, SCALP AND BODY; NON-MEDICATED PREPARATIONS FOR USE ON THE SKIN, SCALP, HAIR AND BODY; OIL FOR THE BODY; NON-MEDICATED OILS FOR THE BODY; PERFUMED BODY LOTIONS; PERFUMED BODY

**CLASS 3—(Continued).**

SPRAYS; NON-MEDICATED POWDERS FOR THE BODY; PREPARATIONS FOR USE IN ADDING BODY TO THE HAIR; PUMICE STONES FOR USE ON THE BODY; SOAP FREE WASHING EMULSIONS FOR THE BODY; NON-MEDICATED SPRAYS FOR THE BODY; NON-MEDICATED SPRAYS FOR USE ON THE BODY; SPRAYS FOR USE ON THE BODY; ROOM FRAGRANCES; ROOM FRAGRANCING PREPARATIONS; ROOM PERFUME SPRAYS; ROOM PERFUMES IN SPRAY FORM; ROOM SCENTING SPRAYS; CONDITIONERS FOR TREATING THE HAIR; CONDITIONERS FOR USE ON THE HAIR; CONDITIONING PREPARATIONS FOR THE HAIR; COSMETICS FOR THE USE ON THE HAIR; CREAMS FOR THE HAIR; GELS FOR USE ON THE HAIR; HAIR BALM; HAIR STYLING PREPARATIONS; HAIR CARE PREPARATIONS; HAIR CARE PREPARATIONS; HAIR CONDITIONER; HAIR CONDITIONING PREPARATIONS; HAIR CONDITIONING RINSES; HAIR COSMETICS; HAIR CREAM; HAIR GEL; HAIR GROOMING PREPARATIONS; HAIR LACQUER; HAIR LOTIONS; HAIR MOISTURISERS; HAIR MOUSSE; HAIR OIL; SHAMPOOS FOR HUMAN HAIR; SHAMPOOS FOR THE HAIR; BEAUTY FACE PACKS; CLEANING MASKS FOR THE FACE; CLEANSERS FOR THE FACE; CLEANSING MASKS FOR THE FACE; COSMETIC FACE POWDERS; COSMETIC PREPARATIONS FOR USE ON THE FACE; FACE BLUSHER; FACE DUSTING POWDERS; FACE FOUNDATION CREAMS; FACE PAINT; FOUNDATIONS FOR THE FACE; NON-MEDICATED MASKS FOR THE FACE; NON-MEDICATED ANTI-BACTERIAL FACE WASHES; NON-MEDICATED CREAMS FOR THE FACE; NON-MEDICATED FACE CREAM; NON-MEDICATED FACE LOTION; PAPER FACE TOWELS IMPREGNATED WITH A COSMETIC PREPARATION; PAPER FACE TOWELS IMPREGNATED WITH SKINCARE PREPARATION; NON-MEDICATED POWDERS FOR THE FACE; ALMOND SOAP; ANTIPERSPIRANT SOAP; BAR SOAP; BATH SOAP; CAKES OF SOAP; CAKES OF TOILET SOAP; CARBOLIC SOAPS; COSMETIC SOAPS; DEODORANT SOAP; DEODORISING SOAPS; DISINFECTANT SOAP; DISINFECTANT SOAP SOLUTIONS; FACIAL SOAPS; FLOATING SOAPS; LIQUID SOAPS; MEDICATED SOAP; NON-MEDICATED SOAPS; NON-MEDICATED TOILET SOAPS; PERFUMED SOAPS; PERFUMED TOILET SOAPS; PREPARATIONS CONTAINING SOAPS FOR THE SKIN, SCALP, HAIR AND BODY; SHAVING SOAP; SHOWER SOAP; SOAP; SOAP CREAMS FOR USE IN WASHING; SOAP FOR FOOT PERSPIRATION; SOAP PADS; SOAP POWDERS; SOAP PREPARATIONS; SOAPS; SPONGES IMPREGNATED WITH SOAP FOR PERSONAL USE; SUGAR SOAP; SUNSCREEN PREPARATIONS; SUNSCREENS; AFTER SUN CREAMS; AFTER SUN LOTIONS; AFTER SUN MOISTURISERS; AFTER SUN PREPARATIONS; OILS FOR MOISTURISING THE SKIN AFTER SUN BATHING; DEODORANT CREAMS FOR PERSONAL USE; DEODORANT PREPARATIONS FOR PERSONAL USE; DEODORANT SPRAYS FOR PERSONAL USE; DEODORANT STICKS FOR PERSONAL USE; NON-MEDICATED DOUCHING PREPARATIONS FOR PERSONAL SANITARY OR DEODORANT PURPOSES; SCENTED DEODORANT PREPARATIONS FOR PERSONAL USE; NON-MEDICATED MASSAGE CREAMS; NON-MEDICATED MASSAGE OILS; NON-MEDICATED MASSAGE PREPARATIONS; NON-MEDICATED BABY BATH PREPARATIONS; BABY LOTIONS; BABY OIL; BABY SHAMPOO; AFTERSHAVE BALM; NON-MEDICATED BALMS FOR THE CARE OF SKIN, SCALP, HAIR AND BODY; NON-MEDICATED FOOT BALMS; NON-MEDICATED LIP BALMS; NON-MEDICATED SKIN BALMS; NON-MEDICATED SKIN BALMS; AFTER SHOWER CREAMS; AFTERSHAVE CREAMS; ANTI-AGING CREAMS; ANTI-AGING CREAMS; NON-MEDICATED BABIES' CREAMS; BARRIER CREAMS; NON-MEDICATED CREAMS TO PROTECT THE SKIN, HAIR, FACE AND BODY; BATH CREAMS, NOT MEDICATED; BEAUTY CREAMS; BLEACHES IN THE FORM OF CREAM FOR THE HAIR OR FACE; BRONZING CREAMS; CLEANING CREAMS FOR USE ON THE PERSON; CLEANSING CREAMS; COCOA BUTTER IN THE FORM OF CREAMS; CONDITIONING SKIN CREAMS; COSMETIC ACNE CREAMS; COSMETIC CREAMS; COSMETICS IN THE FORM OF CREAMS; CREAMS FOR FIRING THE SKIN; CREAMS FOR FURNITURE; CREAMS FOR LEATHER; CREAMS FOR PALING THE SKIN; CREAMS FOR TANNING THE

**CLASS 3—(Continued).**

SKIN; CREAMS FOR TONING THE SKIN; CREAMS FOR USE AFTER SHAVING; CREAMS FOR USE BEFORE SHAVING; CREAMS FOR WRINKLES; DAY CREAMS; DEPILATORY CREAMS; NON-MEDICATED DERMATOLOGICAL CREAMS FOR THE CARE OF THE SKIN; EMOLLIENT SKIN CREAMS; COSMETIC FACIAL CREAMS; COSMETIC HAND AND HAIR PROTECTING PREPARATIONS; COSMETIC MOISTURISING CREAMS; COSMETIC MOISTURISING SKIN CREAMS; COSMETIC NAIL TREATMENT CREAMS; COSMETIC NIGHT CREAMS; NON-MEDICATED CLEANSING CREAMS; NON-MEDICATED CREAMS; NON-MEDICATED CREAMS FOR APPLICATION AFTER EXPOSURE TO THE SUN; NON-MEDICATED CREAMS FOR APPLICATION BEFORE EXPOSURE TO THE SUN; NON-MEDICATED CREAMS FOR FACIAL SCRUBS; NON-MEDICATED CREAMS FOR HYDRATING THE SKIN; NON-MEDICATED CREAMS FOR MOISTURISING THE SKIN; NON-MEDICATED CREAMS FOR PERSONAL CARE; NON-MEDICATED CREAMS FOR PROTECTION AGAINST THE SUN; NON-MEDICATED CREAMS FOR PROTECTION OF THE SKIN; NON-MEDICATED CREAMS FOR SOFTENING THE SKIN; NON-MEDICATED CREAMS FOR SOOTHING THE SKIN; NON-MEDICATED CREAMS FOR THE EYES; NON-MEDICATED CREAMS FOR THE FEET; NON-MEDICATED CREAMS FOR THE LIPS; NON-MEDICATED CREAMS FOR THE SKIN; NON-MEDICATED FOOT CREAMS; NON-MEDICATED PROTECTIVE CREAMS; NON-MEDICATED SKIN CREAMS; NON-MEDICATED SUNTAN CREAMS; COSMETIC NOURISHING CREAMS; PERFUMED CREAMS; PRE-SHAVE CREAMS; COSMETIC SELF TANNING CREAMS; SHAVING CREAMS; COSMETIC SKIN CARE CREAMS; COSMETIC SKIN CREAMS; SKIN WHITENING CREAMS; COSMETIC SUN CREAMS; COSMETIC SUN PROTECTING CREAMS; COSMETIC TANNING CREAMS; TONING CREAMS FOR FACE AND BODY; ALMOND LOTION FOR COSMETIC PURPOSES; ALMOND LOTION FOR COSMETIC USE; ALMOND MILK FOR COSMETIC PURPOSES; ASTRINGENTS FOR COSMETIC PURPOSES; BLEACHING PREPARATIONS (DECOLOURANTS) FOR COSMETIC PURPOSES; COSMETIC CHEMICAL PREPARATIONS FOR BLEACHING THE SKIN AND HAIR; CLEANING OILS FOR COSMETIC PURPOSES; COSMETIC COLLAGEN PREPARATIONS FOR FACE AND BODY; COLORING AGENTS FOR COSMETIC PURPOSES; COLOURING PREPARATIONS FOR COSMETIC PURPOSES; COLOURS FOR COSMETIC PURPOSES; COSMETIC ACNE CLEANSERS; COSMETIC BATH PREPARATIONS FOR SKIN, FACE, BODY HAIR AND SCALP; COSMETIC COTTON WOOL; HAIR DYES; COSMETIC EYE GELS; COSMETIC EYE PENCILS; COSMETIC MAKE-UP AND BODY CARE KITS COMPRISING OF, BUT NOT LIMITED TO, FACE AND BODY PREPARATIONS, HAIR DYES, BLEACHING PREPARATIONS FOR FACE AND BODY, LIPSTICK, LIP GLOSS, FOUNDATION, CONCEALER, MOISTURISER, EYELINER, MASCARA, HEAT AND COOLING PACKS AND FACE AND SKIN COSMETIC MASKS AND TREATMENTS; COSMETIC MASKS; COSMETIC MOISTURISERS; COSMETIC OILS; COSMETIC PENCILS; COSMETIC POWDER; COSMETIC PREPARATIONS; COSMETIC PREPARATIONS ADAPTED FOR SUN-TANNING; COSMETIC PREPARATIONS FOR APPLICATION TO THE NAILS; COSMETIC PREPARATIONS FOR BATHS; COSMETIC PREPARATIONS FOR CLEANSING THE MOUTH; COSMETIC PREPARATIONS FOR CLEANSING THE SKIN; COSMETIC PREPARATIONS FOR CLEANSING THE TEETH; COSMETIC PREPARATIONS FOR EYELASHES; COSMETIC PREPARATIONS FOR SKIN CARE; COSMETIC PREPARATIONS FOR SKIN TANNING; COSMETIC PREPARATIONS FOR SLIMMING PURPOSES; COSMETIC PREPARATIONS FOR TANNING THE SKIN; COSMETIC PREPARATIONS FOR USE IN GIVING A SUN-TAN EFFECT; COSMETIC PREPARATIONS FOR USE IN SUN TANNING; COSMETIC PREPARATIONS FOR USE IN THE BATH; COSMETIC PREPARATIONS FOR USE ON THE SKIN; COSMETIC PREPARATIONS FOR EYEBROWS; COSMETIC PREPARATIONS FOR EYELASHES; COSMETIC PREPARATIONS FOR PROTECTION AGAINST THE SUN; COSMETIC PREPARATIONS FOR SKIN CARE; COSMETIC SKIN CARE PREPARATIONS; COTTON BALLS FOR COSMETIC USE; COTTON BUDS FOR COSMETIC USE; COTTON FOR COSMETIC PURPOSES; COTTON PADS FOR COSMETIC USE; COTTON STICKS

**CLASS 3—(Continued).**

FOR COSMETIC PURPOSES; COTTON SWABS FOR COSMETIC PURPOSES; COTTON TIPPED STICKS FOR COSMETIC PURPOSES; COTTON WOOL BALLS FOR COSMETIC USE; COTTON WOOL BUDS FOR COSMETIC USE; COTTON WOOL FOR COSMETIC PURPOSES; COTTON WOOL IN THE FORM OF BALLS FOR COSMETIC USE; COTTON WOOL IN THE FORM OF BUDS FOR COSMETIC USE; COTTON WOOL IN THE FORM OF PADS FOR COSMETIC USE; COTTON WOOL IN THE FORM OF ROLLS FOR COSMETIC USE; COTTON WOOL IN THE FORM OF STICKS FOR COSMETIC USE; COTTON WOOL IN THE FORM OF SWABS FOR COSMETIC USE; COTTON WOOL IN THE FORM OF WIPES FOR COSMETIC USE; COTTON WOOL TIPS FOR COSMETIC PURPOSES; DECORATIVE TRANSFERS FOR COSMETIC PURPOSES; DERMATOLOGICAL COSMETIC PREPARATIONS FOR CARE OF THE SKIN; HAIR DYES FOR COSMETIC USE; ESSENTIAL OILS FOR COSMETIC PURPOSES; EYE LOTIONS FOR COSMETIC USE; EYE MOISTURISERS FOR COSMETIC USE; EYE COMPRESSES FOR COSMETIC USE; COSMETIC FACIAL CARE PREPARATIONS; COSMETIC FACIAL LOTIONS; FACIAL MASKS COSMETIC; FACIAL MOISTURISERS COSMETIC; NON-MEDICATED PREPARATIONS FOR THE FACE; GLITTER FOR COSMETIC PURPOSES; GREASES FOR COSMETIC PURPOSES; HYDROGEN PEROXIDE FOR COSMETIC PURPOSES; IMPREGNATED CLOTHS FOR COSMETIC USE; IMPREGNATED PADS CONTAINING COSMETIC PREPARATIONS; LOTIONS FOR COSMETIC PURPOSES; MINERAL OILS FOR COSMETIC PURPOSES; MINERAL WATER SPRAYS FOR COSMETIC PURPOSES; NATURAL OILS FOR COSMETIC PURPOSES; NON-MEDICATED COSMETIC PREPARATIONS; OIL FOR COSMETIC USE; OILS FOR COSMETIC PURPOSES; NON-MEDICATED OINTMENTS FOR THE PREVENTION AND TREATMENT OF SUNBURN TO IMPROVE THE APPEARANCE OR TEXTURE OF SKIN AND BODY; PAPER TISSUES IMPREGNATED WITH COSMETIC PREPARATIONS; PAPER TOWELS IMPREGNATED WITH COSMETIC PREPARATIONS; PAPER WIPES IMPREGNATED WITH COSMETIC PREPARATIONS; PENCILS FOR COSMETIC USE; PETROLEUM JELLY FOR COSMETIC PURPOSES; POMADES FOR COSMETIC PURPOSES; NAIL POLISH; PUMICE STONES FOR COSMETIC PURPOSES; COSMETIC ROUGE; COSMETIC SELF-TANNING LOTIONS; COSMETIC SELF-TANNING MISTS; COSMETIC SELF-TANNING PREPARATIONS; COSMETIC SKIN CARE LOTIONS; COSMETIC SKIN CARE OILS; COSMETIC SKIN CARE PREPARATIONS; COSMETIC SKIN CLEANSERS; COSMETIC SKIN CLEANSING CREAM; COSMETIC SKIN CLEANSING PREPARATIONS; SKIN JEWELS FOR COSMETIC PURPOSES; COSMETIC SKIN LIGHTENING COMPOSITIONS; COSMETIC SKIN LOTIONS; COSMETIC PREPARATIONS FOR SLIMMING PURPOSES; COSMETIC SUN TAN LOTIONS; DECORATIVE TRANSFERS FOR COSMETIC PURPOSES; TISSUES IMPREGNATED WITH COSMETIC LOTIONS; COSMETIC HAIR TONICS; PLANT AND HERB EXTRACTS SOLD AS COMPONENTS OF COSMETICS; BODY SPRAYS, NAMELY, WATER IN ATOMIZED CONTAINERS USED TO PRODUCE A COOLING EFFECT; WIPES AND TISSUES IMPREGNATED WITH COSMETIC LOTIONS; WIPES FOR TOILET USE IMPREGNATED WITH COSMETIC PREPARATIONS; FACIAL CLEANSERS; HAND CLEANSERS (U.S. CLS. 1, 4, 6, 50, 51 AND 52).

ANGELA M. MICHELI, EXAMINING ATTORNEY

**CLASS 3—(Continued).**

SN 79-075,876. STRATEGEM, F-75001 PARIS, FRANCE, FILED 9-29-2009.

# FIGARO

PRIORITY DATE OF 9-24-2009 IS CLAIMED.  
OWNER OF INTERNATIONAL REGISTRATION 1020923 DATED 9-29-2009, EXPIRES 9-29-2019.  
THE NAME "FIGARO" DOES NOT IDENTIFY A LIVING INDIVIDUAL.  
FOR PERFUMES; TOILET WATER; PERFUMERY; SOAPS, NAMELY, SOAPS FOR PERSONAL USE; COSMETICS; NON-MEDICATED SKIN CARE PREPARATIONS; MAKE-UP; SHAMPOOS; DENTIFRICES (U.S. CLS. 1, 4, 6, 50, 51 AND 52).  
JAMES MACFARLANE, EXAMINING ATTORNEY

SN 79-076,897. SELF CARE CORPORATION PTY LTD, AUSTRALIA, FILED 11-11-2009.



PRIORITY DATE OF 5-11-2009 IS CLAIMED.  
OWNER OF INTERNATIONAL REGISTRATION 1023771 DATED 11-11-2009, EXPIRES 11-11-2019.  
NO CLAIM IS MADE TO THE EXCLUSIVE RIGHT TO USE "COSMETIC PHYSICIAN'S PRESCRIPTION", APART FROM THE MARK AS SHOWN.  
THE COLOR(S) BROWN, BLUE, BLACK, AND WHITE IS/ARE CLAIMED AS A FEATURE OF THE MARK.  
THE MARK CONSISTS OF THE WORDING "CPRx COSMETIC PHYSICIAN'S PRESCRIPTION" IN BLACK WITH A DESIGN OF A BROWN, BLACK, AND WHITE DROPPER WITH BLUE LIQUID AND A BLUE DROP COMING OUT.  
FOR TOPICAL ANTI-AGING PREPARATIONS, NAMELY, ANTI-AGING CLEANSERS, ANTI-AGING CREAMS, ANTI-AGING MOISTURIZERS, AND ANTI-AGING TONERS (U.S. CLS. 1, 4, 6, 50, 51 AND 52).  
MATTHEW EINSTEIN, EXAMINING ATTORNEY

**CLASS 3—(Continued).**

SN 79-084,062. LA PRESQU'ILE, FRANCE, FILED 3-5-2010.

# LA PRESQU'ILE

THE MARK CONSISTS OF STANDARD CHARACTERS WITHOUT CLAIM TO ANY PARTICULAR FONT, STYLE, SIZE, OR COLOR.

PRIORITY DATE OF 9-11-2009 IS CLAIMED.  
OWNER OF INTERNATIONAL REGISTRATION 1042786 DATED 3-5-2010, EXPIRES 3-5-2020.

THE ENGLISH TRANSLATION OF THE FOREIGN WORD(S) IN THE MARK IS: THE PENINSULA.

FOR SOAPS, PERFUMERY, ESSENTIAL OILS, COSMETICS, HAIR LOTIONS, COSMETIC BATH PREPARATIONS, COSMETIC TANNING PREPARATIONS, COSMETIC PREPARATIONS FOR SLIMMING PURPOSES, COSMETIC PREPARATIONS FOR SKIN CARE; NUTRITIONAL ADDITIVES CONTAINING PROTEINS, CARBOHYDRATES, LIPIDS, PEPTIDES AND/OR FIBRES, OR MICRONUTRIENTS SUCH AS VITAMINS AND/OR MINERALS AND/OR AMINO ACIDS AND/OR FATTY AND/OR VEGETABLE ACIDS AND/OR PLANT EXTRACTS AND/OR PURIFIED PLANT AND/OR WEED EXTRACT MOLECULES AND/OR WEED EXTRACTS, FOR BEAUTY AND SKIN, BODY, FACIAL, HAIR OR NAIL CARE, IN THE FORM OF CAPSULES, TABLETS, AMPULES, YEAST, POWDERS, BARS, CREAMS OR BEVERAGES (U.S. CLS. 1, 4, 6, 50, 51 AND 52).

DOMINICK J. SALEMI, EXAMINING ATTORNEY

SN 79-084,762. PRIVITY PTY LTD, AUSTRALIA, FILED 6-23-2010.

# EVO

THE MARK CONSISTS OF STANDARD CHARACTERS WITHOUT CLAIM TO ANY PARTICULAR FONT, STYLE, SIZE, OR COLOR.

PRIORITY DATE OF 12-23-2009 IS CLAIMED.  
OWNER OF INTERNATIONAL REGISTRATION 1044408 DATED 6-23-2010, EXPIRES 6-23-2020.

FOR HAIR LOTIONS (U.S. CLS. 1, 4, 6, 50, 51 AND 52).  
KELLY TRUSILO, EXAMINING ATTORNEY

**CLASS 3—(Continued).**

SN 79-086,452. EVRARD MICHÈLE, FRANCE, FILED 6-15-2010.

# BAUME 27

OWNER OF INTERNATIONAL REGISTRATION 1048653 DATED 6-15-2010, EXPIRES 6-15-2020.

NO CLAIM IS MADE TO THE EXCLUSIVE RIGHT TO USE "BAUME", APART FROM THE MARK AS SHOWN.

THE ENGLISH TRANSLATION OF "BAUME" IN THE MARK IS "BALM".

FOR FACE AND BODY CARE COSMETICS; PRODUCTS FOR TREATING, MAINTAINING AND IMPROVING THE SKIN, NAMELY, FACIAL CREAMS, REPARATIVE CREAMS AND BEAUTY CARE, REGENERATIVE CREAMS, NOURISHING AND ANTI-AGING CREAMS; EXFOLIANT LOTIONS AND MOISTURISERS; PERFUMES; TOILET WATER; BATH AND SHOWER GELS AND SALTS FOR NON-MEDICAL USE; TOILET SOAP; BODY DEODORANTS; COSMETICS PARTICULARLY FACE, BODY AND HAND CREAMS, MILKS, LOTIONS, GELS AND POWDERS; TANNING AND AFTER-SUN MILKS, GELS AND OILS FOR COSMETIC PURPOSES; MAKE-UP PREPARATIONS; ESSENTIAL OILS (U.S. CLS. 1, 4, 6, 50, 51 AND 52).

MARILYN IZZI, EXAMINING ATTORNEY

SN 85-004,850. OJON CORPORATION, NEW YORK, NY. FILED 4-2-2010.

# FULL DETOX

THE MARK CONSISTS OF STANDARD CHARACTERS WITHOUT CLAIM TO ANY PARTICULAR FONT, STYLE, SIZE, OR COLOR.

NO CLAIM IS MADE TO THE EXCLUSIVE RIGHT TO USE "DETOX", APART FROM THE MARK AS SHOWN.

FOR HAIR CARE PREPARATIONS (U.S. CLS. 1, 4, 6, 50, 51 AND 52).

TIMOTHY FINNEGAN, EXAMINING ATTORNEY

SN 85-005,281. COLLIER MANUFACTURING, LLC, FAIRVIEW, OR. FILED 4-2-2010.

# SLIMY GREEN & SLIPPERY BLACK

THE MARK CONSISTS OF STANDARD CHARACTERS WITHOUT CLAIM TO ANY PARTICULAR FONT, STYLE, SIZE, OR COLOR.

FOR CLEANING PREPARATIONS (U.S. CLS. 1, 4, 6, 50, 51 AND 52).

WENDY GOODMAN, EXAMINING ATTORNEY

**CLASS 3—(Continued).**

SN 85-006,107. TAYLOR, TEGAN, LONG BEACH, CA. FILED 4-5-2010.

# MOCAP INK, BY: MOCAP FX

THE MARK CONSISTS OF STANDARD CHARACTERS WITHOUT CLAIM TO ANY PARTICULAR FONT, STYLE, SIZE, OR COLOR.

NO CLAIM IS MADE TO THE EXCLUSIVE RIGHT TO USE "MOCAP" AND "FX", APART FROM THE MARK AS SHOWN.

FOR COSMETIC PREPARATIONS FOR THE SKIN IN THE NATURE MAKE-UP, FACIAL MARKER PAINT, AND MAKE-UP FOR USE IN MOTION CAPTURE, ALSO KNOWN AS MOCAP, COMPUTER GENERATED IMAGERY, ALSO KNOWN AS CGI, GREEN SCREEN, AND ALL FORMS OF DIGITAL MEDIA, OR MEDIA IN GENERAL (U.S. CLS. 1, 4, 6, 50, 51 AND 52).

FIRST USE 1-1-2005; IN COMMERCE 1-1-2005.

JULIE GUTTADAURO, EXAMINING ATTORNEY

SN 85-007,380. YAEL MAMROUD/ CUMMINS, MONTREAL, CANADA, FILED 4-6-2010.



FOR ORGANIC HAIR CARE AND SKIN CARE PRODUCTS, NAMELY, SHAMPOO, CONDITIONER, STYLING CREAMS, HAIR GELS, HAIR SPRAYS, SKIN WATER TONERS, BATH SALTS, FACE AND BODY CREAMS, AND SKIN MOISTURIZERS (U.S. CLS. 1, 4, 6, 50, 51 AND 52).

JOSETTE BEVERLY, EXAMINING ATTORNEY

**CLASS 3—(Continued).**

SN 85-009,337. UNILEVER SUPPLY CHAIN, INC., CLINTON, CT. FILED 4-8-2010.

**CLASS 3—(Continued).**

SN 85-016,767. SASI HOLDINGS PTY LTD, ENGLISHTOWN, NJ. FILED 4-19-2010.

**ORANGE ALLEY-OOP**

THE MARK CONSISTS OF STANDARD CHARACTERS WITHOUT CLAIM TO ANY PARTICULAR FONT, STYLE, SIZE, OR COLOR.

NO CLAIM IS MADE TO THE EXCLUSIVE RIGHT TO USE "ORANGE", APART FROM THE MARK AS SHOWN.

FOR SOAPS; PERFUMERY; ESSENTIAL OILS; DEODORANTS AND ANTIPERSPIRANTS; HAIR CARE PREPARATIONS; HAIR COLORANTS, HAIR DYES, HAIR LOTIONS, HAIR WAVING PREPARATIONS, SHAMPOOS, CONDITIONERS, HAIR SPRAYS, HAIR WASHING POWDER, HAIR DRESSINGS, HAIR LACQUERS, HAIR MOUSSES, HAIR GLAZES, HAIR GELS, HAIR MOISTURIZERS, HAIR WASHING LIQUID, HAIR OILS, HAIR TONIC, HAIR CREAMS, NON-MEDICATED PREPARATIONS FOR THE BATH AND/OR SHOWER; NON-MEDICATED TOILET PREPARATIONS; NON-MEDICATED SKIN CARE PREPARATIONS; COSMETICS (U.S. CLS. 1, 4, 6, 50, 51 AND 52).

REBECCA EISINGER, EXAMINING ATTORNEY

SN 85-011,392. SCHERING-PLOUGH HEALTHCARE PRODUCTS, INC., MEMPHIS, TN. FILED 4-12-2010.

**SWEATACT**

THE MARK CONSISTS OF STANDARD CHARACTERS WITHOUT CLAIM TO ANY PARTICULAR FONT, STYLE, SIZE, OR COLOR.

FOR NON-MEDICATED FOOT POWDERS AND SPRAYS (U.S. CLS. 1, 4, 6, 50, 51 AND 52).

MEGHAN REINHART, EXAMINING ATTORNEY

THE MARK CONSISTS OF STANDARD CHARACTERS WITHOUT CLAIM TO ANY PARTICULAR FONT, STYLE, SIZE, OR COLOR.

OWNER OF AUSTRALIA REG. NO. 1180397, DATED 6-7-2007, EXPIRES 6-7-2017.

FOR CONDITIONERS; GEL FOR HAIR; HAIR CARE CREAMS; HAIR CARE KITS COMPRISING NON-MEDICATED HAIR CARE PREPARATIONS, NAMELY, CONDITIONER, GEL; HAIR CARE LOTIONS; HAIR CARE PREPARATIONS; HAIR CONDITIONERS; HAIR CREAMS; HAIR CURLING PREPARATIONS; HAIR GEL; HAIR GEL AND HAIR MOUSSE; HAIR GELS; HAIR GLAZE; HAIR LACQUERS; HAIR LOTIONS; HAIR MOUSSES; HAIR PRODUCTS, NAMELY, THICKENING CONTROL CREAMS; HAIR RELAXING PREPARATIONS; HAIR SHEEN SPRAY; HAIR SPRAYS AND HAIR GELS; HAIR STRAIGHTENING PREPARATIONS; HAIR STYLING FIXATIVE IN THE NATURE OF HAIR WAX; HAIR STYLING GEL; HAIR STYLING PREPARATIONS; HAIR STYLING SPRAY; HAIR WAVING LOTION; HAIR WAVING PREPARATIONS; HAIR WAX; LOTIONS FOR HAIR, HAIR WAVING; MOUSSE FOR HAIR; PREPARATIONS FOR SETTING HAIR; STYLING FOAM FOR HAIR; STYLING PASTE FOR HAIR (U.S. CLS. 1, 4, 6, 50, 51 AND 52).

ANDREW LEASER, EXAMINING ATTORNEY



**CLASS 3—(Continued).**

SN 85-018,038. DUPUIS, JESSICA, AMHERST, MA. FILED 4-20-2010.



NO CLAIM IS MADE TO THE EXCLUSIVE RIGHT TO USE "OLIVE" OR "BEAUTY" OR THE PICTORIAL REPRESENTATION OF THE OLIVE AND OLIVE BRANCH, APART FROM THE MARK AS SHOWN.

THE MARK CONSISTS OF AN OLIVE FRUIT ON AN OLIVE BRANCH WITH LEAVES GROWING OFF THE BRANCH AND THE STYLIZED TEXT "OLIVE NATURAL BEAUTY".

FOR NATURAL AND ORGANIC OLIVE OIL-BASED BEAUTY CARE PRODUCTS, NAMELY, BODY SCRUBS, LIP BALMS, NON-MEDICATED SKIN SALVES, BATH OILS AND SALTS, BODY LOTIONS, HAIR SHAMPOOS AND CONDITIONERS, BODY SPLASHES AND SPRAYS, BAR SOAPS, BODY CREAMS, FACIAL CREAMS, FACIAL MASKS, FACIAL CLEANSERS, BODY CLEANSERS, PERFUMES, EYE CREAMS, FACIAL SCRUBS, HAND LOTIONS AND CREAMS, HAND SOAPS, MASSAGE OILS AND LOTIONS, SHOWER CREAMS AND GELS, AND TONING LOTIONS FOR THE FACE, BODY AND HANDS (U.S. CLS. 1, 4, 6, 50, 51 AND 52).

FIRST USE 8-10-2009; IN COMMERCE 8-10-2009.  
CHRISTINE MARTIN, EXAMINING ATTORNEY

SN 85-019,215. MICHAEL BECK INTERNATIONAL LLC, FRESH MEADOWS, NY. FILED 4-21-2010.

**saryna KEY  
PROFESSIONAL**

THE MARK CONSISTS OF STANDARD CHARACTERS WITHOUT CLAIM TO ANY PARTICULAR FONT, STYLE, SIZE, OR COLOR.

NO CLAIM IS MADE TO THE EXCLUSIVE RIGHT TO USE "PROFESSIONAL", APART FROM THE MARK AS SHOWN.

FOR COSMETIC CREAMS FOR SKIN CARE; COSMETIC MASKS; COSMETICS AND COSMETIC PREPARATIONS; HAIR CARE CREAMS; HAIR GLAZE; HAIR LOTIONS; HAIR SHAMPOOS AND CONDITIONERS; HAIR STYLING PREPARATIONS (U.S. CLS. 1, 4, 6, 50, 51 AND 52).

FIRST USE 8-1-2009; IN COMMERCE 8-1-2009.  
DOMINIC FATHY, EXAMINING ATTORNEY

**CLASS 3—(Continued).**

SN 85-027,291. PETER GREVEN PHYSIODERM GMBH, EUSKIRCHEN, FED REP GERMANY, FILED 4-30-2010.



NO CLAIM IS MADE TO THE EXCLUSIVE RIGHT TO USE "HEAVY DUTY", APART FROM THE MARK AS SHOWN.

THE MARK CONSISTS OF THE STYLIZED WORDING "ACTIVESTRENGTH HEAVY DUTY HD" AND A SQUARE DESIGN.

FOR PRODUCTS USED IN CLEANING, NAMELY, HAND CLEANERS (U.S. CLS. 1, 4, 6, 50, 51 AND 52).  
BRIAN PINO, EXAMINING ATTORNEY

SN 85-027,333. PETER GREVEN PHYSIODERM GMBH, EUSKIRCHEN, FED REP GERMANY, FILED 4-30-2010.



NO CLAIM IS MADE TO THE EXCLUSIVE RIGHT TO USE "ANTI BOND", APART FROM THE MARK AS SHOWN.

THE MARK CONSISTS OF THE STYLIZED WORDING "ACTIVEULTRA ANTI BOND AB" AND A SQUARE DESIGN.

FOR PRODUCTS USED IN CLEANING, NAMELY, HAND CLEANERS (U.S. CLS. 1, 4, 6, 50, 51 AND 52).  
BRIAN PINO, EXAMINING ATTORNEY

SN 85-027,617. ASAM, MARCUS, D-85774 UNTERFOHRING, FED REP GERMANY, AND ASAM, MIRJAM, D-85774 UNTERFOHRING, FED REP GERMANY, FILED 4-30-2010.

**ExpressLifter**

THE MARK CONSISTS OF STANDARD CHARACTERS WITHOUT CLAIM TO ANY PARTICULAR FONT, STYLE, SIZE, OR COLOR.

PRIORITY CLAIMED UNDER SEC. 44(D) ON ERP CMNTY TM OFC APPLICATION NO. 009105628, FILED 4-30-2010, REG. NO. 009105628, DATED 9-23-2010, EXPIRES 4-30-2020.

FOR COSMETICS (U.S. CLS. 1, 4, 6, 50, 51 AND 52).  
JOHN WILKE, EXAMINING ATTORNEY

**CLASS 3—(Continued).**

SN 85-028,214. ORLANDO SUN & SKIN CARE, INC., WINDERMERE, FL. FILED 5-2-2010.



OWNER OF U.S. REG. NO. 2,786,234.  
THE MARK CONSISTS OF THE LETTERS "ORLANDO" IN UPPERCASE STYLIZED FONT TO THE RIGHT OF A DRAWING OF THE SUN WHICH SERVES AS THE LETTER "O" IN "ORLANDO".

SEC. 2(F) AS TO "ORLANDO".

FOR AROMATIC BODY CARE PRODUCTS, NAMELY, BODY LOTION, SHOWER GEL, CUTICLE CREAM, SHAMPOO, CONDITIONER, NON-MEDICATED LIP BALM, SOAP, BODY POLISH, BODY AND FOOT SCRUB AND NON-MEDICATED FOOT CREAM; FRAGRANCES FOR PERSONAL USE; SUN TAN LOTION (U.S. CLS. 1, 4, 6, 50, 51 AND 52).

FIRST USE 3-17-2003, THE MARK WAS FIRST USED ANYWHERE IN A DIFFERENT FORM OTHER THAN THAT SOUGHT TO BE REGISTERED AT LEAST AS EARLY AS 06/01/2001.; IN COMMERCE 3-17-2003, THE MARK WAS FIRST USED IN COMMERCE IN A DIFFERENT FORM OTHER THAN THAT SOUGHT TO BE REGISTERED AT LEAST AS EARLY AS 12/20/2001..

BILL DAWE, EXAMINING ATTORNEY

**CLASS 3—(Continued).**

SN 85-032,713. THE PROCTER & GAMBLE COMPANY, CINCINNATI, OH. FILED 5-7-2010.

WRINKLE REVOLUTION COMPLEX

THE MARK CONSISTS OF STANDARD CHARACTERS WITHOUT CLAIM TO ANY PARTICULAR FONT, STYLE, SIZE, OR COLOR.

NO CLAIM IS MADE TO THE EXCLUSIVE RIGHT TO USE "WRINKLE" AND "COMPLEX", APART FROM THE MARK AS SHOWN.

FOR NON-MEDICATED SKIN CARE PREPARATIONS (U.S. CLS. 1, 4, 6, 50, 51 AND 52).

INGRID C. EULIN, EXAMINING ATTORNEY

SN 85-031,815. FASHION WORLD, INC., DBA BIJAN, BEVERLY HILLS, CA. FILED 5-6-2010.

OWNER OF U.S. REG. NO. 3,804,160.  
THE NAME "BIJAN" IDENTIFIES A LIVING INDIVIDUAL WHOSE CONSENT IS OF RECORD.

THE MARK CONSISTS OF THE WORDING "BIJAN" IN STYLIZED FONT.

FOR COGNES, PERFUMES AND COSMETICS; COSMETICS IN GENERAL, INCLUDING PERFUMES; EAU DE PERFUME; LIQUID PERFUMES; OILS FOR PERFUMES AND SCENTS; PERFUME; PERFUME OILS; PERFUME OILS FOR THE MANUFACTURE OF COSMETIC PREPARATIONS; PERFUMED CREAMS; PERFUMED EXTRACTS FOR TISSUES AND PERFUMES; PERFUMED POWDER; PERFUMED SOAP; PERFUMED TALCUM POWDER (U.S. CLS. 1, 4, 6, 50, 51 AND 52).

FIRST USE 2-20-1987; IN COMMERCE 2-20-1987.

TOBY BULLOFF, EXAMINING ATTORNEY

SN 85-033,423. VICTORIA PRINCIPAL PRODUCTIONS, INC., LOS ANGELES, CA. FILED 5-7-2010.

VICTORIA PRINCIPAL V.P.

THE MARK CONSISTS OF STANDARD CHARACTERS WITHOUT CLAIM TO ANY PARTICULAR FONT, STYLE, SIZE, OR COLOR.

OWNER OF U.S. REG. NO. 3,610,326.

THE NAME(S), PORTRAIT(S), AND/OR SIGNATURE(S) SHOWN IN THE MARK IDENTIFIES "VICTORIA PRINCIPAL", WHOSE CONSENT(S) TO REGISTER IS MADE OF RECORD.

FOR COSMETICS; SKIN CARE PRODUCTS, NAMELY, LOTIONS, CREAMS, NON-MEDICATED SOAPS; NON-MEDICATED HAIR CARE PRODUCTS, NAMELY, SHAMPOOS, CONDITIONERS; AND FRAGRANCE PRODUCTS, NAMELY, PERFUMES, BODY SPRAY, INCENSE AND ROOM FRAGRANCES; AND POTPOURRI (U.S. CLS. 1, 4, 6, 50, 51 AND 52).

DEIRDRE ROBERTSON, EXAMINING ATTORNEY

**CLASS 3—(Continued).**

SN 85-035,116. UNILEVER SUPPLY CHAIN, INC., CLINTON, CT. FILED 5-11-2010.

**CLASS 3—(Continued).**

SN 85-035,451. UNILEVER SUPPLY CHAIN, INC., CLINTON, CT. FILED 5-11-2010.

**UNDERSTATED LOOK**

THE MARK CONSISTS OF STANDARD CHARACTERS WITHOUT CLAIM TO ANY PARTICULAR FONT, STYLE, SIZE, OR COLOR.

FOR SOAPS; PERFUMERY, ESSENTIAL OILS, COSMETICS; COLOGNES, EAU DE TOILETTE, PERFUMED BODY SPRAYS; OILS FOR THE SKIN FOR COSMETIC USE, CREAMS AND LOTIONS FOR THE SKIN; SHAVING FOAM, SHAVING GEL, PRE-SHAVING AND AFTER-SHAVING LOTIONS; TALCUM POWDER; NON-MEDICATED PREPARATIONS FOR THE BATH AND SHOWER; HAIR LOTIONS; HAIR CARE PREPARATIONS; HAIR COLORANTS, HAIR DYES, HAIR LOTIONS, HAIR WAVING PREPARATIONS, HAIR SHAMPOOS, HAIR CONDITIONERS, HAIR SPRAYS, HAIR LACQUERS, HAIR MOUSSES, HAIR GLAZES, HAIR GELS, HAIR MOISTURIZERS IN THE NATURE OF HAIR MOISTURIZING CONDITIONER, HAIR PRESERVATION TREATMENTS IN THE NATURE OF HAIR CONDITIONERS, HAIR OILS, HAIR TONIC, HAIR CREAMS, NON-MEDICATED PREPARATIONS FOR THE BATH AND/OR SHOWER; DEODORANTS FOR PERSONAL USE; ANTI-PERSPIRANTS FOR PERSONAL USE (U.S. CLS. 1, 4, 6, 50, 51 AND 52).

LAURIE MAYES, EXAMINING ATTORNEY

---

SN 85-035,656. DE ROBLIN INC., CITY OF INDUSTRY, CA. FILED 5-11-2010.

THE COLOR(S) BLUE, WHITE AND GRAY IS/ARE CLAIMED AS A FEATURE OF THE MARK.

THE MARK CONSISTS OF A BLUE RING THAT CONTAINS THE WHITE LANGUAGE "TURN OFF THE TAP" ON IT. INSIDE THE RING ARE A BLUE AND WHITE LIQUID DROP AND A GRAY CIRCLE WITH A WHITE DOLLAR SIGN INSIDE. THE INTERIOR PORTION OF THE RING HAS A WHITE BACKGROUND.

FOR SOAPS; PERFUMERY; ESSENTIAL OILS; DEODORANTS AND ANTIPERSPIRANTS; NON-MEDICATED HAIR CARE PREPARATIONS; HAIR COLORANTS, HAIR DYES, HAIR LOTIONS, HAIR WAVING PREPARATIONS, HAIR SHAMPOOS, HAIR CONDITIONERS, HAIR SPRAYS, COSMETICS HAIR DRESSINGS FOR MEN AND WOMEN, HAIR LACQUERS, HAIR MOUSSES, HAIR GLAZES, HAIR GELS, HAIR MOISTURIZING CREAMS, CONDITIONER AND GEL, HAIR PRESERVATION TREATMENTS IN THE NATURE OF HAIR CONDITIONERS, HAIR OILS, HAIR TONIC, HAIR CREAMS, NON-MEDICATED PREPARATIONS FOR THE BATH AND/OR SHOWER; TOILET WATER, TALCUM POWDER FOR TOILET USE; NON-MEDICATED SKIN CARE PREPARATIONS; COSMETICS (U.S. CLS. 1, 4, 6, 50, 51 AND 52).

LAURIE MAYES, EXAMINING ATTORNEY

**MIA SECRET CRACKLE**

THE MARK CONSISTS OF STANDARD CHARACTERS WITHOUT CLAIM TO ANY PARTICULAR FONT, STYLE, SIZE, OR COLOR.

OWNER OF U.S. REG. NO. 3,338,658.

NO CLAIM IS MADE TO THE EXCLUSIVE RIGHT TO USE "CRACKLE", APART FROM THE MARK AS SHOWN. FOR NAIL POLISH (U.S. CLS. 1, 4, 6, 50, 51 AND 52). FIRST USE 5-5-2010; IN COMMERCE 5-5-2010.

MARK SHINER, EXAMINING ATTORNEY

**CLASS 3—(Continued).**

SN 85-036,064. MARY KAY INC., ADDISON, TX. FILED 5-12-2010.

**COLOR TILES**

THE MARK CONSISTS OF STANDARD CHARACTERS WITHOUT CLAIM TO ANY PARTICULAR FONT, STYLE, SIZE, OR COLOR.

NO CLAIM IS MADE TO THE EXCLUSIVE RIGHT TO USE "COLOR", APART FROM THE MARK AS SHOWN.

FOR BLUSH; COSMETIC ROUGES; COSMETICS; CREAMY FACE POWDER; EYE SHADOWS; FACE POWDER; MAKE-UP POWDER; NON-MEDICATED LIP CARE PREPARATIONS; PRESSED FACE POWDER (U.S. CLS. 1, 4, 6, 50, 51 AND 52).

AMY C. KEAN, EXAMINING ATTORNEY

---

SN 85-056,123. AUSTRALIAN GOLD, LLC, INDIANAPOLIS, IN. FILED 6-7-2010.

**NATURAL NERD**

THE MARK CONSISTS OF STANDARD CHARACTERS WITHOUT CLAIM TO ANY PARTICULAR FONT, STYLE, SIZE, OR COLOR.

NO CLAIM IS MADE TO THE EXCLUSIVE RIGHT TO USE "NATURAL", APART FROM THE MARK AS SHOWN.

FOR BODY LOTIONS; SHOWER GELS; BODY SCRUBS; BODY BUTTERS; LIP GLOSS; SHAMPOO; CONDITIONERS; HAIR CARE PREPARATIONS; NON-MEDICATED INDOOR AND OUTDOOR SKIN TANNING PREPARATIONS (U.S. CLS. 1, 4, 6, 50, 51 AND 52).

MICHELLE DUBOIS, EXAMINING ATTORNEY

---

SN 85-059,923. JLW-TW CORP, AVON, OH. FILED 6-10-2010.

**CINNAMON CHOCOLATE**

THE MARK CONSISTS OF STANDARD CHARACTERS WITHOUT CLAIM TO ANY PARTICULAR FONT, STYLE, SIZE, OR COLOR.

FOR COSMETIC SUNTAN LOTIONS (U.S. CLS. 1, 4, 6, 50, 51 AND 52).

FIRST USE 6-4-2010; IN COMMERCE 6-4-2010.

JANET LEE, EXAMINING ATTORNEY

**CLASS 3—(Continued).**

SN 85-061,772. L'OREAL, PARIS, FRANCE, FILED 6-14-2010.

**AQUA DESTOCK**

THE MARK CONSISTS OF STANDARD CHARACTERS WITHOUT CLAIM TO ANY PARTICULAR FONT, STYLE, SIZE, OR COLOR.

PRIORITY CLAIMED UNDER SEC. 44(D) ON FRANCE APPLICATION NO. 103744593, FILED 6-8-2010, REG. NO. 103744593, DATED 6-8-2010, EXPIRES 6-8-2020.

FOR PERFUME, EAU DE TOILETTE; GELS, SALTS FOR THE BATH AND THE SHOWER NOT FOR MEDICAL PURPOSE; TOILET SOAPS, BODY DEODORANTS; COSMETICS, NAMELY, CREAMS, MILKS, LOTIONS, GELS AND POWDERS FOR THE FACE, THE BODY AND THE HANDS; NON-MEDICATED SUN CARE PREPARATIONS; MAKEUP PREPARATIONS; SHAMPOOS; GELS, SPRAYS, MOUSSES AND BALMS FOR HAIR STYLING AND HAIR CARE; HAIR LACQUERS; HAIR COLORING AND HAIR DECOLORANT PREPARATIONS; PERMANENT WAVING AND CURLING PREPARATIONS; ESSENTIAL OILS FOR PERSONAL USE (U.S. CLS. 1, 4, 6, 50, 51 AND 52).

TARAH HARDY, EXAMINING ATTORNEY

---

SN 85-063,003. UNILEVER SUPPLY CHAIN, INC., CLINTON, CT. FILED 6-15-2010.

**IGNITING CITRUS**

THE MARK CONSISTS OF STANDARD CHARACTERS WITHOUT CLAIM TO ANY PARTICULAR FONT, STYLE, SIZE, OR COLOR.

NO CLAIM IS MADE TO THE EXCLUSIVE RIGHT TO USE "CITRUS", APART FROM THE MARK AS SHOWN.

FOR SOAPS; PERFUMERY; ESSENTIAL OILS; DEODORANTS AND ANTIPERSPIRANTS; NON-MEDICATED HAIR CARE PREPARATIONS; HAIR COLORANTS, HAIR DYES, HAIR LOTIONS, HAIR WAVING PREPARATIONS, HAIR SHAMPOOS, HAIR CONDITIONERS, HAIR SPRAYS, COSMETICS HAIR DRESSINGS FOR MEN AND WOMEN, HAIR LACQUERS, HAIR MOUSSES, HAIR GLAZES, HAIR GELS, HAIR MOISTURIZERS IN THE NATURE OF HAIR CONDITIONERS, HAIR PRESERVATION TREATMENTS IN THE NATURE OF HAIR CONDITIONERS, HAIR DESICCATING TREATMENTS IN THE NATURE OF HAIR SHAMPOO FOR OILY HAIR, HAIR OILS, HAIR TONIC, HAIR CREAMS, NON-MEDICATED PREPARATIONS FOR THE BATH AND/OR SHOWER; NON-MEDICATED SKIN CARE PREPARATIONS; COSMETICS (U.S. CLS. 1, 4, 6, 50, 51 AND 52).

Laurie Mayes, Examining Attorney

**CLASS 3—(Continued).**

SN 85-066,980. DE ROBLIN INC., CITY OF INDUSTRY, CA.  
FILED 6-19-2010.

**MIA SECRET TINT**

THE MARK CONSISTS OF STANDARD CHARACTERS  
WITHOUT CLAIM TO ANY PARTICULAR FONT, STYLE,  
SIZE, OR COLOR.

OWNER OF U.S. REG. NO. 3,338,658.

NO CLAIM IS MADE TO THE EXCLUSIVE RIGHT TO  
USE "TINT", APART FROM THE MARK AS SHOWN.

FOR NAIL POLISH (U.S. CLS. 1, 4, 6, 50, 51 AND 52).

FIRST USE 6-4-2010; IN COMMERCE 6-4-2010.

MARK SHINER, EXAMINING ATTORNEY

SN 85-082,506. RATHBUN, NIEVES, DBA BY NIEVES, OAK-  
LAND, CA. FILED 7-12-2010.

**Face Fix**

THE MARK CONSISTS OF STANDARD CHARACTERS  
WITHOUT CLAIM TO ANY PARTICULAR FONT, STYLE,  
SIZE, OR COLOR.

NO CLAIM IS MADE TO THE EXCLUSIVE RIGHT TO  
USE "FACE", APART FROM THE MARK AS SHOWN.

FOR FACIAL MASKS; FACIAL SCRUBS (U.S. CLS. 1,  
4, 6, 50, 51 AND 52).

FIRST USE 6-10-2009; IN COMMERCE 7-8-2010.

ALYSSA STEEL, EXAMINING ATTORNEY

SN 85-083,591. UNIVERSAL PRODUCT MARKETING, INC.,  
CLINTON TWP., MI. FILED 7-13-2010.

**HAIRSIL ACCELERATOR**

THE MARK CONSISTS OF STANDARD CHARACTERS  
WITHOUT CLAIM TO ANY PARTICULAR FONT, STYLE,  
SIZE, OR COLOR.

NO CLAIM IS MADE TO THE EXCLUSIVE RIGHT TO  
USE "ACCELERATOR", APART FROM THE MARK AS  
SHOWN.

FOR HAIR SHAMPOO; HAIR CARE PREPARATIONS  
(U.S. CLS. 1, 4, 6, 50, 51 AND 52).

FIRST USE 5-25-2009; IN COMMERCE 3-26-2010.

CHRIS WELLS, EXAMINING ATTORNEY

**CLASS 3—(Continued).**

SN 85-090,066. BARONCREST ENTERPRISES LLC, PARA-  
DISE VALLEY, AZ. FILED 7-21-2010.

**FACTOR IV**

THE MARK CONSISTS OF STANDARD CHARACTERS  
WITHOUT CLAIM TO ANY PARTICULAR FONT, STYLE,  
SIZE, OR COLOR.

FOR NAIL STRENGTHENERS; NON-MEDICATED  
PREPARATIONS ALL FOR THE CARE OF SKIN, HAIR  
AND SCALP (U.S. CLS. 1, 4, 6, 50, 51 AND 52).

ALEX KEAM, EXAMINING ATTORNEY

SN 85-096,431. VIGOR-25, FORMERLY PURE VITAMINS  
AND NATURAL SUPPLEMENTS, LLC, IRVINE, CA 92612,  
CA. FILED 7-29-2010.

**Vigor-25**

THE MARK CONSISTS OF STANDARD CHARACTERS  
WITHOUT CLAIM TO ANY PARTICULAR FONT, STYLE,  
SIZE, OR COLOR.

OWNER OF U.S. REG. NOS. 3,660,860, 3,745,881 AND  
3,769,906.

FOR INCENSE (U.S. CLS. 1, 4, 6, 50, 51 AND 52).

FIRST USE 7-20-2007; IN COMMERCE 7-20-2007.

TASNEEM HUSSAIN, EXAMINING ATTORNEY

SN 85-096,461. FIBIANCA GROUP INC, OSLO, NORWAY,  
FILED 7-30-2010.

**PLUMBO**

THE MARK CONSISTS OF STANDARD CHARACTERS  
WITHOUT CLAIM TO ANY PARTICULAR FONT, STYLE,  
SIZE, OR COLOR.

FOR CHEMICALS MADE INTO A FINISHED PRO-  
DUCT, NAMELY, CLEANING PREPARATIONS USED  
FOR CLEANSING PIPES AND FLOW LINES, DILUTING  
ORGANIC AND OTHER WASTE, CLEARING PIPE AND  
FLOW LINES OF CIRCULATING LIQUID OR SOLID  
COMPOSITIONS, AND REMOVING MATERIAL WASTE  
BLOCKAGES BY DECOMPOSITION, FOR USE BY  
TRADE MEN IN INDUSTRY AND HOUSEHOLDS (U.S.  
CLS. 1, 4, 6, 50, 51 AND 52).

YAT SYE, LEE, EXAMINING ATTORNEY

**CLASS 3—(Continued).**

SN 85-098,359. VERY WITTE PRODUCTS, LLC, HOUSTON, TX. FILED 8-2-2010.

## Yogini Cleanies

THE MARK CONSISTS OF STANDARD CHARACTERS WITHOUT CLAIM TO ANY PARTICULAR FONT, STYLE, SIZE, OR COLOR.

NO CLAIM IS MADE TO THE EXCLUSIVE RIGHT TO USE "YOGINI", APART FROM THE MARK AS SHOWN.

FOR CLEANING PREPARATIONS FOR YOGA MATS, BODIES AND EXERCISE EQUIPMENT; DISPOSABLE WIPES IMPREGNATED WITH ORGANIC ESSENTIAL OILS AND CLEANSING COMPOUNDS FOR CLEANING YOGA MATS, BODIES AND EXERCISE EQUIPMENT (U.S. CLS. 1, 4, 6, 50, 51 AND 52).

FIRST USE 11-15-2010; IN COMMERCE 1-6-2011.  
ELIZABETH HUGHITT, EXAMINING ATTORNEY

SN 85-098,607. VERY WITTE PRODUCTS, LLC, HOUSTON, TX. FILED 8-3-2010.



NO CLAIM IS MADE TO THE EXCLUSIVE RIGHT TO USE "YOGINI", APART FROM THE MARK AS SHOWN.

THE MARK CONSISTS OF PERSON IN YOGA POSE (LOTUS POSITION) EXHIBITING CROSSED LEGS AND HANDS TOGETHER HOLDING CLEANING WIPE WITH WORDS "YOGINI CLEANIES" VISIBLE ON LEGS.

FOR CLEANING PREPARATIONS FOR YOGA MATS, BODIES AND EXERCISE EQUIPMENT; DISPOSABLE WIPES IMPREGNATED WITH ORGANIC ESSENTIAL OILS AND CLEANSING COMPOUNDS FOR CLEANING YOGA MATS, BODIES AND EXERCISE EQUIPMENT (U.S. CLS. 1, 4, 6, 50, 51 AND 52).

FIRST USE 11-15-2010; IN COMMERCE 1-6-2011.  
ELIZABETH HUGHITT, EXAMINING ATTORNEY

**CLASS 3—(Continued).**

SN 85-101,166. VERY WITTE PRODUCTS, LLC, HOUSTON, TX. FILED 8-5-2010.

## Keeping it Clean and Green

THE MARK CONSISTS OF STANDARD CHARACTERS WITHOUT CLAIM TO ANY PARTICULAR FONT, STYLE, SIZE, OR COLOR.

FOR CLEANING PREPARATIONS FOR YOGA MATS, BODIES AND EXERCISE EQUIPMENT; DISPOSABLE WIPES IMPREGNATED WITH ORGANIC ESSENTIAL OILS AND CLEANSING COMPOUNDS FOR CLEANING YOGA MATS, BODIES AND EXERCISE EQUIPMENT (U.S. CLS. 1, 4, 6, 50, 51 AND 52).

FIRST USE 11-15-2010; IN COMMERCE 1-6-2011.  
ELIZABETH HUGHITT, EXAMINING ATTORNEY

SN 85-108,847. BIO KOR METICS LTD., BNEI BRAK, ISRAEL, FILED 8-17-2010.

## Peelosophy

OWNER OF ISRAEL REG. NO. 224614, DATED 2-7-2011, EXPIRES 11-1-2019.

THE MARK CONSISTS OF THE WORD "PEELOSOPHY" IN A STYLIZED FORM, WITH THE PART "PEEL" IN BOLD LETTERS.

FOR BODY AND BEAUTY CARE COSMETICS; COSMETIC CREAMS; COSMETIC MASKS; COSMETIC PREPARATIONS; COSMETICS IN THE FORM OF MILKS, LOTIONS AND EMULSIONS; SKIN AND BODY TOPICAL LOTIONS, CREAMS AND OILS FOR COSMETIC USE; SKIN CONDITIONING CREAMS FOR COSMETIC PURPOSES (U.S. CLS. 1, 4, 6, 50, 51 AND 52).

APRIL ROACH, EXAMINING ATTORNEY

SN 85-110,767. INDUSTRIAS SALCOM S.A. DE C.V., AKA WIESE, FLORENCE, KY. FILED 8-18-2010.



THE COLOR(S) PURPLE, GREEN AND WHITE IS/ARE CLAIMED AS A FEATURE OF THE MARK.

THE MARK CONSISTS OF THE STYLIZED WORDING "WIESE" IN WHITE WITHIN MULTIPLE OVALS OF PURPLE WITH A GREEN OVAL AS THE OUTERMOST OVAL. FOR SCENTED ROOM SPRAYS (U.S. CLS. 1, 4, 6, 50, 51 AND 52).

FIRST USE 1-1-1997; IN COMMERCE 10-1-2009.  
ANNE MADDEN, EXAMINING ATTORNEY

**CLASS 3—(Continued).**

SN 85-135,187. MARKS, BRIAN K., WHITESTONE, NY. FILED 9-22-2010.

# ISRAEL'S MIRACLE

THE MARK CONSISTS OF STANDARD CHARACTERS WITHOUT CLAIM TO ANY PARTICULAR FONT, STYLE, SIZE, OR COLOR.

NO CLAIM IS MADE TO THE EXCLUSIVE RIGHT TO USE "ISRAEL'S", APART FROM THE MARK AS SHOWN.

FOR HAIR CARE AND HAIR TREATMENT PREPARATIONS, NAMELY, HAIR SHAMPOO, HAIR CONDITIONERS, HAIR OILS, NON-MEDICATED HAIR BALMS, HAIR CREAMS, HAIR RINSES, HAIR LOTIONS, HAIR GELS; SKIN CARE AND SKIN TREATMENT PREPARATIONS, NAMELY, SKIN CLEANSERS, SKIN LOTIONS, SKIN CREAMS, SKIN MASKS, GELS, EXFOLIANTS, SKIN MOISTURIZERS, SKIN SOAPS, SKIN TONERS, FACIAL SCRUBS (U.S. CLS. 1, 4, 6, 50, 51 AND 52).

JANET LEE, EXAMINING ATTORNEY

SN 85-143,486. BLAKE AUSTIN COLLEGE, VACAVILLE, CA. FILED 10-1-2010.

# LIV FOREVER

THE MARK CONSISTS OF STANDARD CHARACTERS WITHOUT CLAIM TO ANY PARTICULAR FONT, STYLE, SIZE, OR COLOR.

FOR SKIN CLEANSERS, SKIN TONERS, SKIN MOISTURIZERS, SKIN EXFOLIANTS, SKIN MASQUES, SERUMS, NON-MEDICATED CHEMICAL PEELS FOR SKIN, BODY SCRUBS, LIP GLOSS FORMULATED TO MAKE LIPS LOOK FULLER, SUN BLOCK, TINTED SUN BLOCK, COLLAGEN-BASED COSMETIC MASKS, EYE LASH LENGTHENER, NON-MEDICATED SKIN CARE PREPARATIONS, NON-MEDICATED EYE CARE PREPARATIONS, NON-MEDICATED ACNE TREATMENT PREPARATIONS, AND NON-MEDICATED BODY TREATMENTS (U.S. CLS. 1, 4, 6, 50, 51 AND 52).

DAVID TOOLEY, EXAMINING ATTORNEY

**CLASS 3—(Continued).**

SN 85-144,579. FF TRADEMARK LLC, NEW YORK, NY. FILED 10-4-2010.

# PERFECTLY LUSCIOUS CURLS

THE MARK CONSISTS OF STANDARD CHARACTERS WITHOUT CLAIM TO ANY PARTICULAR FONT, STYLE, SIZE, OR COLOR.

OWNER OF U.S. REG. NO. 2,877,862.

NO CLAIM IS MADE TO THE EXCLUSIVE RIGHT TO USE "CURLS", APART FROM THE MARK AS SHOWN.

FOR HAIR CARE PREPARATIONS (U.S. CLS. 1, 4, 6, 50, 51 AND 52).

SOPHIA S. KIM, EXAMINING ATTORNEY

SN 85-144,621. FF TRADEMARK LLC, NEW YORK, NY. FILED 10-4-2010.

# SHINELIGHT COMPLEX

THE MARK CONSISTS OF STANDARD CHARACTERS WITHOUT CLAIM TO ANY PARTICULAR FONT, STYLE, SIZE, OR COLOR.

NO CLAIM IS MADE TO THE EXCLUSIVE RIGHT TO USE "COMPLEX", APART FROM THE MARK AS SHOWN.

FOR HAIR CARE PREPARATIONS (U.S. CLS. 1, 4, 6, 50, 51 AND 52).

SOPHIA S. KIM, EXAMINING ATTORNEY

SN 85-147,034. LAURICE EL BADRY RAHME LTD. DBA LAURICE & CO., NEW YORK, NY. FILED 10-7-2010.

# BRONX

THE MARK CONSISTS OF STANDARD CHARACTERS WITHOUT CLAIM TO ANY PARTICULAR FONT, STYLE, SIZE, OR COLOR.

FOR FRAGRANCES FOR PERSONAL USE, NAMELY, PERFUMES AND COLOGNES; AFTER BATH BODY SPLASHES, BODY SPRAYS, SHOWER GELS, SOAPS, BODY LOTIONS, MASSAGE OILS; COSMETICS, NAMELY, NON-MEDICATED SKIN CARE PREPARATIONS, MAKEUP, LIPSTICK, FOUNDATION FACE POWDER, EYESHADOW, NAIL POLISH, MASCARA AND EYE PENCILS (U.S. CLS. 1, 4, 6, 50, 51 AND 52).

BENJAMIN OKEKE, EXAMINING ATTORNEY

**CLASS 3—(Continued).**

SN 85-152,240. INEKE LLC, SAN FRANCISCO, CA. FILED 10-14-2010.

## Floral Curiosities

THE MARK CONSISTS OF STANDARD CHARACTERS WITHOUT CLAIM TO ANY PARTICULAR FONT, STYLE, SIZE, OR COLOR.

NO CLAIM IS MADE TO THE EXCLUSIVE RIGHT TO USE "FLORAL", APART FROM THE MARK AS SHOWN.

FOR COLOGNES, PERFUMES AND COSMETICS; EAU DE PERFUME; EAU DE TOILETTE; EAU DE TOILETTE AND EAU DE COLOGNE; EAU-DE-TOILETTE; EAUX DE TOILETTE; FRAGRANCES; FRAGRANCES AND PERFUMERY; FRAGRANCES FOR PERSONAL USE; LIQUID PERFUMES; PERFUME; PERFUMERY; PERFUMES; PERFUMES AND COLOGNES; PERFUMES AND TOILET WATERS; PERFUMES, EAU DE COLOGNES AND AFTERSHAVES; SYNTHETIC PERFUMERY (U.S. CLS. 1, 4, 6, 50, 51 AND 52).

WILLIAM BRECKENFELD, EXAMINING ATTORNEY

---

SN 85-152,579. CALVIN KLEIN TRADEMARK TRUST, NEW YORK, NY. FILED 10-14-2010.

## CK CRASH

THE MARK CONSISTS OF STANDARD CHARACTERS WITHOUT CLAIM TO ANY PARTICULAR FONT, STYLE, SIZE, OR COLOR.

OWNER OF U.S. REG. NOS. 1,946,318, 2,234,623 AND OTHERS.

FOR EAU DE TOILETTE, SKIN MOISTURIZER, BODY MASSAGE OIL, BODY WASH, SOAP, PERSONAL DEODORANT, TALC, OILS FOR HAIR CONDITIONING, SHAMPOO, HAIR GEL, ALL FOR MEN AND WOMEN (U.S. CLS. 1, 4, 6, 50, 51 AND 52).

WILLIAM VERHOSEK, EXAMINING ATTORNEY

**CLASS 3—(Continued).**

SN 85-152,822. AURA SKIN SPA #1 INC., SAN FRANCISCO, CA. FILED 10-14-2010.



NO CLAIM IS MADE TO THE EXCLUSIVE RIGHT TO USE "SKIN SPA REJUVENATION", APART FROM THE MARK AS SHOWN.

THE COLOR(S) DARK BLUE AND LIGHT BLUE IS/ARE CLAIMED AS A FEATURE OF THE MARK.

THE MARK CONSISTS OF FOUR SMALLER SQUARES IN ALTERNATING DARK BLUE AND LIGHT BLUE COLORS, PUT TOGETHER TO FORM A LARGER SQUARE, AND BENEATH THAT THE WORD "AURA" IN DARK BLUE FOLLOWED BY THE WORDS "SKIN SPA" IN LIGHT BLUE, AND BENEATH THAT THE WORDS "REJUVENATION THROUGH SCIENCE" IN LIGHT BLUE.

FOR AGE RETARDANT GEL; AGE RETARDANT LOTION; AGE SPOT REDUCING CREAMS; ANTI-AGING CLEANSER; ANTI-AGING CREAMS; ANTI-AGING MOISTURIZER; ANTI-AGING TONER; ANTI-FRECKLE CREAMS; ANTI-WRINKLE CREAMS; BEAUTY CREAMS; BEAUTY GELS; BEAUTY LOTIONS; BEAUTY MASKS; COSMETIC HAND CREAMS; COSMETIC NOURISHING CREAMS; COSMETIC PREPARATIONS FOR PROTECTING THE SKIN FROM THE SUN'S RAYS; COSMETIC PREPARATIONS FOR SKIN CARE; COSMETIC PREPARATIONS FOR SKIN RENEWAL; EXFOLIANT CREAMS; FACE AND BODY CREAMS; FACE AND BODY LOTIONS; FACIAL CLEANSERS; FACIAL CREAMS; FACIAL LOTION; FACIAL MASKS; FACIAL SCRUBS; FACIAL WASHES; LOTIONS FOR CELLULITE REDUCTION; LOTIONS FOR COSMETIC PURPOSES; LOTIONS FOR FACE AND BODY CARE; MOISTURIZING CREAMS; MOISTURIZING PREPARATIONS FOR THE SKIN; MOISTURIZING SOLUTIONS FOR THE SKIN; NON-MEDICATED SKIN CARE CREAMS AND LOTIONS; NON-MEDICATED SKIN CARE PREPARATIONS, NAMELY, CREAMS, LOTIONS, GELS, TONERS, CLEANERS AND PEELS; SKIN AND BODY TOPICAL LOTIONS, CREAMS AND OILS FOR COSMETIC USE; SKIN CONDITIONERS; SKIN LIGHTENING CREAMS; SKIN LOTIONS; SKIN MASKS; SKIN MOISTURIZER; SKIN MOISTURIZER MASKS; SKIN MOISTURIZING GEL; SKIN TONERS; WRINKLE REMOVING SKIN CARE PREPARATIONS; WRINKLE RESISTANT CREAM; WRINKLE-MINIMIZING COSMETIC PREPARATIONS FOR TOPICAL FACIAL USE (U.S. CLS. 1, 4, 6, 50, 51 AND 52).

LAURIE MAYES, EXAMINING ATTORNEY

---

SN 85-152,936. AURORA PHARMACEUTICAL, LLC, NORTHFIELD, MN. FILED 10-14-2010.

## ZEODRI PLUS

THE MARK CONSISTS OF STANDARD CHARACTERS WITHOUT CLAIM TO ANY PARTICULAR FONT, STYLE, SIZE, OR COLOR.

FOR NON-MEDICATED POWDER USED ON FARM ANIMALS TO ABSORB MOISTURE AND TO REDUCE ODOR (U.S. CLS. 1, 4, 6, 50, 51 AND 52).

FIRST USE 12-0-2009; IN COMMERCE 12-0-2009.

MELISSA VALLILLO, EXAMINING ATTORNEY



**CLASS 3—(Continued).**

SN 85-153,619. LAKHIVA BLANN, DBA BLANN ENTERPRISES, LLC, LITTLE ROCK, AR. FILED 10-15-2010.

**LcB Nail Lacquer**

THE MARK CONSISTS OF STANDARD CHARACTERS WITHOUT CLAIM TO ANY PARTICULAR FONT, STYLE, SIZE, OR COLOR.

NO CLAIM IS MADE TO THE EXCLUSIVE RIGHT TO USE "NAIL LACQUER", APART FROM THE MARK AS SHOWN.

THE LETTERS, "LCB" IN THE MARK IDENTIFY A LIVING INDIVIDUAL WHOSE CONSENT IS OF RECORD.

FOR ADHESIVES FOR ARTIFICIAL NAILS; ADHESIVES FOR FALSE EYELASHES, HAIR AND NAILS; FALSE NAILS; LOTIONS FOR STRENGTHENING THE NAILS; NAIL BUFFING PREPARATIONS; NAIL CARE PREPARATIONS; NAIL CARE PREPARATIONS, NAMELY, NAIL SOFTENERS; NAIL CREAM; NAIL ENAMEL; NAIL ENAMEL REMOVERS; NAIL ENAMELS; NAIL GLITTER; NAIL GROOMING PRODUCTS, NAMELY, TIPS, GLUE, LACQUER AND GLITTER; NAIL HARDENERS; NAIL POLISH; NAIL POLISH BASE COAT; NAIL POLISH PROTECTOR IN THE NATURE OF A THIN PLASTIC COVERING APPLIED TO NAILS; NAIL POLISH REMOVER; NAIL POLISH REMOVERS; NAIL POLISH TOP COAT; NAIL REPAIR PRODUCTS, NAMELY, LINEN NAIL WRAPS; NAIL REPAIR PRODUCTS, NAMELY, NAIL WRAPS; NAIL REPAIR PRODUCTS, NAMELY, SILK NAIL WRAPS; NAIL STENCILS; NAIL STRENGTHENERS; NAIL TIPS; NAIL VARNISH; NAIL VARNISH FOR COSMETIC PURPOSES; NAIL VARNISHES; NAIL-POLISH REMOVERS (U.S. CLS. 1, 4, 6, 50, 51 AND 52).

ODESSA BIBBINS, EXAMINING ATTORNEY

**CLASS 3—(Continued).**

SN 85-156,210. LO VI POR TV, LLC, HIALEAH, FL. FILED 10-19-2010.

**VARICLEGS**

THE MARK CONSISTS OF STANDARD CHARACTERS WITHOUT CLAIM TO ANY PARTICULAR FONT, STYLE, SIZE, OR COLOR.

FOR COSMETIC SKIN FRESHENERS; MOISTURIZING PREPARATIONS FOR THE SKIN; NON-MEDICATED COSMETIC SKIN CARE PREPARATIONS CONSISTING OF ORGANIC COCONUT VIRGIN OIL AND COCONUT VIRGIN OIL; NON-MEDICATED SKIN CARE CREAMS AND LOTIONS; NON-MEDICATED SKIN CREAMS; NON-MEDICATED STIMULATING LOTIONS FOR THE SKIN; SKIN CARE PRODUCTS, NAMELY, NON-MEDICATED SKIN SERUM; SKIN CLEANSER IN LIQUID SPRAY FORM FOR USE AS A BABY WIPE ALTERNATIVE; SKIN CONDITIONERS; SKIN CONDITIONING CREAMS FOR COSMETIC PURPOSES; SKIN CREAM; SKIN CREAMS; SKIN CREAMS IN LIQUID AND IN SOLID FORM; SKIN CREAMS IN LIQUID AND SOLID; SKIN FRESHENERS; SKIN LOTION; SKIN LOTIONS; SKIN MOISTURIZER; SKIN MOISTURIZING GEL; SKIN TONERS; TOPICAL SKIN SPRAYS FOR COSMETIC PURPOSES (U.S. CLS. 1, 4, 6, 50, 51 AND 52).

FIRST USE 7-1-2010; IN COMMERCE 8-1-2010.

KATHERINE CHANG, EXAMINING ATTORNEY

SN 85-154,857. JULES, CELINE, HIALEAH, FL. FILED 10-18-2010.

**BAURIVAGE**  
LUXURY

THE COLOR(S) BROWN IS/ARE CLAIMED AS A FEATURE OF THE MARK.

THE MARK CONSISTS OF THE WORD "BAURIVAGE" IN A BROWN STYLISTIC FONT OVER THE WORD "LUXURY" IN A SMALLER BROWN STYLISTIC FONT, CENTERED BETWEEN 2 BROWN VERTICAL LINES.

FOR ANTIPERSPIRANTS AND DEODORANTS FOR PERSONAL USE; BODY SPRAY USED AS A PERSONAL DEODORANT AND AS FRAGRANCE; COSMETICS IN GENERAL, INCLUDING PERFUMES (U.S. CLS. 1, 4, 6, 50, 51 AND 52).

CHARLES L. JENKINS, EXAMINING ATTORNEY

SN 85-157,246. RUE21, INC., WARRENDALE, PA. FILED 10-20-2010.

**INTENSE BY RUE21**

THE MARK CONSISTS OF STANDARD CHARACTERS WITHOUT CLAIM TO ANY PARTICULAR FONT, STYLE, SIZE, OR COLOR.

OWNER OF U.S. REG. NOS. 2,123,489, 2,407,212 AND OTHERS.

THE ENGLISH TRANSLATION OF THE WORD "RUE" IN THE MARK IS "STREET".

FOR FRAGRANCES FOR PERSONAL USE (U.S. CLS. 1, 4, 6, 50, 51 AND 52).

JORDAN BAKER, EXAMINING ATTORNEY

**CLASS 3—(Continued).**

SN 85-157,936. KOOKLA, NEW YORK, NY. FILED 10-21-2010.



THE MARKS CONSISTS OF THE STYLIZED WORDING "KOOKLA" INSIDE A RECTANGLE. THE RECTANGLE IS SURROUNDED BY A STYLIZED FLOWER AND VINE DESIGN IN THE SHAPE OF AN OVAL.

FOR COSMETICS (U.S. CLS. 1, 4, 6, 50, 51 AND 52).  
TARAH HARDY, EXAMINING ATTORNEY

SN 85-162,009. SOAP &amp; GLORY LIMITED, LONDON, UNITED KINGDOM, FILED 10-27-2010.

# hand food

THE MARK CONSISTS OF STANDARD CHARACTERS WITHOUT CLAIM TO ANY PARTICULAR FONT, STYLE, SIZE, OR COLOR.

OWNER OF UNITED KINGDOM REG. NO. 2416929, DATED 10-6-2006, EXPIRES 10-6-2016.

NO CLAIM IS MADE TO THE EXCLUSIVE RIGHT TO USE "HAND", APART FROM THE MARK AS SHOWN.

FOR COSMETICS HAND PRODUCTS, NAMELY, HAND CARE CREAMS, HAND CARE LOTIONS (U.S. CLS. 1, 4, 6, 50, 51 AND 52).

BENJAMIN OKEKE, EXAMINING ATTORNEY

SN 85-165,285. CAROL LEE ORGANICS LLC, SANDY, UT. FILED 10-29-2010.

# VitaLock

THE MARK CONSISTS OF STANDARD CHARACTERS WITHOUT CLAIM TO ANY PARTICULAR FONT, STYLE, SIZE, OR COLOR.

FOR OILS FOR COSMETIC PURPOSES, NAMELY, VITAMIN E OIL-BASED PH OPTIMIZER THAT PROMOTES COLLAGEN GROWTH (U.S. CLS. 1, 4, 6, 50, 51 AND 52).

FIRST USE 8-1-2010; IN COMMERCE 8-1-2010.  
ROBERT STRUCK, EXAMINING ATTORNEY

**CLASS 3—(Continued).**

SN 85-167,131. MANDELL, ALAN, H., MIAMI, FL. FILED 11-2-2010.



THE COLOR(S) BLACK, VIOLET/PURPLE, RED IS/ARE CLAIMED AS A FEATURE OF THE MARK.

THE MARK CONSISTS OF THE WORDS "FEM BURST" IN BLACK. THE "T" AND THE CIRCLE ABOVE THE "T" ARE VIOLET. IN THE CIRCLE ABOVE THE "T" ARE THREE FLAMES WITH THE OUTER TWO IN PURPLE AND MIDDLE ONE IN RED.

FOR SKIN CREAMS IN LIQUID AND IN SOLID FORM (U.S. CLS. 1, 4, 6, 50, 51 AND 52).

SHAUNIA CARLYLE, EXAMINING ATTORNEY

SN 85-171,518. UGOCHUKWU, EKENE, LANCASTER, CA. FILED 11-8-2010.

## PRECIOUS BABY OLIVE CARE

THE MARK CONSISTS OF STANDARD CHARACTERS WITHOUT CLAIM TO ANY PARTICULAR FONT, STYLE, SIZE, OR COLOR.

NO CLAIM IS MADE TO THE EXCLUSIVE RIGHT TO USE "BABY OLIVE", APART FROM THE MARK AS SHOWN.

FOR BABY LOTION; BABY OIL; BABY SHAMPOO; BODY WASH (U.S. CLS. 1, 4, 6, 50, 51 AND 52).

KEVON CHISOLM, EXAMINING ATTORNEY

SN 85-171,761. WINGS OF HEALTH, INC., SAN ANTONIO, TX. FILED 11-8-2010.

# TOOTH JOY!

THE MARK CONSISTS OF STANDARD CHARACTERS WITHOUT CLAIM TO ANY PARTICULAR FONT, STYLE, SIZE, OR COLOR.

NO CLAIM IS MADE TO THE EXCLUSIVE RIGHT TO USE "TOOTH", APART FROM THE MARK AS SHOWN.

FOR DENTIFRICE (U.S. CLS. 1, 4, 6, 50, 51 AND 52).  
FIRST USE 8-15-2010; IN COMMERCE 8-22-2010.

EDWARD NELSON, EXAMINING ATTORNEY

**CLASS 3—(Continued).**

SN 85-173,163. MEE, LLC, DOUGLASSVILLE, PA. FILED 11-10-2010.

# Mee

THE MARK CONSISTS OF STANDARD CHARACTERS WITHOUT CLAIM TO ANY PARTICULAR FONT, STYLE, SIZE, OR COLOR.

FOR HAIR CARE PRODUCTS, NAMELY, SHAMPOOS, CONDITIONERS, OIL TREATMENTS AND FINISHING SPRAYS (U.S. CLS. 1, 4, 6, 50, 51 AND 52).

FIRST USE 8-10-2010; IN COMMERCE 8-10-2010.  
CHERYL CLAYTON, EXAMINING ATTORNEY

---

SN 85-173,839. VMV LIMITED, WAN CHAI, HONG KONG, FILED 11-10-2010.

# ILLUMINANTS+

THE MARK CONSISTS OF STANDARD CHARACTERS WITHOUT CLAIM TO ANY PARTICULAR FONT, STYLE, SIZE, OR COLOR.

FOR NON-MEDICATED SKIN CARE PREPARATIONS, NAMELY, FACE CLEANSER, FACE CREAMS, FACE TONER, FACE MOISTURIZER, FACE LOTION, BODY LOTION, BODY WASH, SOAP, EYE CREAM, HAND LOTION, NON-MEDICATED FACIAL AND EYE SERUM CONTAINING ANTIOXIDANTS, SKIN BRIGHTENERS, SKIN LIGHTENERS, SKIN CLARIFIERS, SKIN EXFOLIATING PREPARATIONS; ANTIPERSPIRANT; NON-MEDICATED ANTI-AGING AND ANTI-WRINKLE CREAMS, LOTIONS, GELS AND SERUMS; NON-MEDICATED ALPHA AND BETA-HYDROXY BASED SKIN PREPARATIONS; NON-MEDICATED SKIN CARE PREPARATIONS FOR THE TREATMENT OF HYPERPIGMENTATION, PHOTODAMAGE, BLOTCHES, AGE SPOTS AND WRINKLES; COSMETICS AND MAKE-UP PREPARATIONS; SUNSCREEN AND SUNBLOCK PREPARATIONS (U.S. CLS. 1, 4, 6, 50, 51 AND 52).

FIRST USE 3-0-2010; IN COMMERCE 3-0-2010.  
EVELYN BRADLEY, EXAMINING ATTORNEY

---

SN 85-174,225. CELLCEUTICALS SKIN CARE, INC., BEVERLY HILLS, CA. FILED 11-11-2010.

# CELLGENE-XP

THE MARK CONSISTS OF STANDARD CHARACTERS WITHOUT CLAIM TO ANY PARTICULAR FONT, STYLE, SIZE, OR COLOR.

OWNER OF U.S. REG. NO. 3,816,588.  
FOR NON-MEDICATED SKIN CARE PREPARATIONS (U.S. CLS. 1, 4, 6, 50, 51 AND 52).

MARK SPARACINO, EXAMINING ATTORNEY

**CLASS 3—(Continued).**

SN 85-174,265. COMMON GOOD LLC, HILLSDALE, NY. FILED 11-11-2010.

# COMMON GOOD

THE MARK CONSISTS OF STANDARD CHARACTERS WITHOUT CLAIM TO ANY PARTICULAR FONT, STYLE, SIZE, OR COLOR.

FOR HOUSEHOLD CLEANING PREPARATIONS; LAUNDRY SOAP; SOAPS FOR HOUSEHOLD USE; SOAPS FOR PERSONAL USE (U.S. CLS. 1, 4, 6, 50, 51 AND 52).

KELLY TRUSILO, EXAMINING ATTORNEY

---

SN 85-174,388. OD INTERNATIONAL, DBA ONSEN, CHATSWORTH, CA. FILED 11-11-2010.

# Whitecore

THE MARK CONSISTS OF STANDARD CHARACTERS WITHOUT CLAIM TO ANY PARTICULAR FONT, STYLE, SIZE, OR COLOR.

FOR SKIN CARE PREPARATIONS FOR THE FACE AND THE BODY IN THE FORM OF FACIAL MOISTURIZER, FACIAL CREAM, FACIAL FRUIT ACID PEELS FOR SKIN, FACIAL MASK, FACIAL CLEANSER, NON-MEDICATED FACIAL AND EYE SERUM, EYE GEL, ANTI-AGING EYE CREAM, ANTI-AGING FACE CREAM, NON-MEDICATED INSTANT FACE LIFTING CREAM, NON-MEDICATED INSTANT STRETCHING MASK, HAND CREAM, SALT FACIAL SCRUB, BODY CREAM, NON-MEDICATED COSMETIC PREPARATIONS FOR THE BATH IN THE FORM OF BATH SALTS, BATH MINERALS, GELS AND OILS, NON-MEDICATED FOOT CREAM AND BODY LOTION, NON-MEDICATED ANTI-AGING PREPARATIONS IN THE FORM OF LOTIONS, MILKS, CREAMS AND GELS, COSMETIC PREPARATIONS FOR NAIL CARE IN THE FORM OF HAND AND NAIL CONDITIONER LOTION AND GEL (U.S. CLS. 1, 4, 6, 50, 51 AND 52).

MARILYN IZZI, EXAMINING ATTORNEY

**CLASS 3—(Continued).**

SN 85-175,191. HAGERTY TRUST REG., SCHAAN, LIECHTENSTEIN, FILED 11-12-2010.



THE COLOR(S) RED AND WHITE IS/ARE CLAIMED AS A FEATURE OF THE MARK.

THE MARK CONSISTS OF THE LETTER "H" IN WHITE WITHIN A SOLID RED BOX WITH A WHITE STAR IN THE TOP LEFT CORNER OF THE "H".

FOR CLEANING AND STAIN REMOVING PREPARATIONS, NAMELY, LIQUID HOUSEHOLD CLEANERS, SHAMPOOS, SHAMPOO-CONCENTRATES, FOAM SHAMPOOS, DRY SHAMPOOS, STAIN REMOVERS FOR REMOVAL OF STAINS ON CARPETS, RUGS, UPHOLSTERY AND CLOTHING, EXCEPT DISPOSABLE WIPES IMPREGNATED WITH CHEMICALS OR COMPOUNDS FOR HOUSEHOLD USE; PREPARATIONS FOR THE CARE OF FURNITURE, FLOORS, OTHER HOUSEHOLD SURFACES AND LIGHTINGS AND OTHER HOUSEHOLD OBJECTS, NAMELY, WOOD FLOOR CLEANING PREPARATIONS, HARD FLOOR CLEANING PREPARATIONS, CARPET- AND FLOOR CLEANING PREPARATIONS AND CLEANING PREPARATIONS FOR LIGHTING AND OTHER HOUSEHOLD OBJECTS, FOAM CLEANING PREPARATIONS FOR ORIENTAL RUGS, CARPETS, UPHOLSTERY, CAR UPHOLSTERY, CLEANING PREPARATIONS FOR ALL WATER-RESISTANT HARD FLOORS SUCH AS MARBLE, CERAMIC TILES, NATURAL STONE, LINOLEUM, CLEANING PREPARATIONS FOR SEALED PARQUET AND LAMINATE; CLEANING AND IMPREGNATION PREPARATIONS NAMELY, CLEANING PREPARATIONS FOR CARPETS, RUGS, UPHOLSTERY, CURTAINS, CUSHIONS, BLANKETS, TABLECLOTHS AND OTHER HOUSEHOLD TEXTILE GOODS AND ARTICLES OF CLOTHING CONTAINING SOIL RETARDANTS; PREPARATIONS FOR DEGREASING AND REMOVAL OF WAX, OIL AND OTHER RESIDUES FROM FURNITURE, FLOORS AND OTHER HOUSEHOLD SURFACES, NAMELY, DEGREASER AND REMOVER OF WAX, OIL AND OTHER RESIDUES FROM FURNITURE, FLOORS AND OTHER HOUSEHOLD SURFACES; CLEANING PREPARATIONS INCORPORATING SUBSTANCES FOR CONTROL OF ALLERGENS, NAMELY, HOUSEHOLD CLEANING PREPARATIONS INCORPORATING SUBSTANCES FOR CONTROL OF ALLERGENS, SPRAY-ON ANTI-MITE AND DEODORIZING CLEANING PREPARATIONS FOR MATTRESSES, UPHOLSTERY AND TEXTILES; CLEANING PREPARATIONS IMPREGNATED INTO GLOVES, RAGS, CLOTHS AND WIPES, ALL FOR USE IN CLEANING HOUSEHOLD SURFACES AND OBJECTS, NAMELY, HOUSEHOLD CLEANERS IMPREGNATED INTO GLOVES, RAGS, CLOTHS AND WIPES, ALL FOR USE IN CLEANING HOUSEHOLD SURFACES AND OBJECTS, IMPREGNATED WITH CHEMICALS OR COMPOUNDS FOR HOUSEHOLD USE, EXCEPT CHEMICALLY IMPREGNATED POLISHING GLOVES AND DISPOSABLE WIPES (U.S. CLS. 1, 4, 6, 50, 51 AND 52).

DAVID HOFFMAN, EXAMINING ATTORNEY

**CLASS 3—(Continued).**

SN 85-175,198. HAGERTY TRUST REG., SCHAAN, LIECHTENSTEIN, FILED 11-12-2010.



THE MARK CONSISTS OF THE LETTER "H" WITH A STAR ON THE TOP LEFT CORNER OF THE "H".

FOR CLEANING AND STAIN REMOVING PREPARATIONS NAMELY LIQUID HOUSEHOLD CLEANERS, SHAMPOOS, SHAMPOO-CONCENTRATES, FOAM SHAMPOOS, DRY SHAMPOOS, STAIN REMOVERS FOR REMOVAL OF STAINS ON CARPETS, RUGS, UPHOLSTERY AND CLOTHING, EXCEPT DISPOSABLE WIPES IMPREGNATED WITH CHEMICALS OR COMPOUNDS FOR HOUSEHOLD USE; PREPARATIONS FOR THE CARE OF FURNITURE, FLOORS, OTHER HOUSEHOLD SURFACES AND LIGHTINGS AND OTHER HOUSEHOLD OBJECTS NAMELY WOOD FLOOR CLEANING PREPARATIONS, HARD FLOOR CLEANING PREPARATIONS, CARPET- AND FLOOR CLEANING PREPARATIONS AND CLEANING PREPARATIONS FOR LIGHTING AND OTHER HOUSEHOLD OBJECTS, FOAM CLEANING PREPARATIONS FOR ORIENTAL RUGS, CARPETS, UPHOLSTERY, CAR UPHOLSTERY, CLEANING PREPARATIONS FOR ALL WATER-RESISTANT HARD FLOORS SUCH AS MARBLE, CERAMIC TILES, NATURAL STONE, LINOLEUM, CLEANING PREPARATIONS FOR SEALED PARQUET AND LAMINATE; CLEANING AND IMPREGNATION PREPARATIONS NAMELY, CLEANING PREPARATIONS FOR CAPETS, RUGS, UPHOLSTERY, CURTAINS, CUSHIONS, BLANKETS, TABLECLOTHS AND OTHER HOUSEHOLD TEXTILE GOODS AND ARTICLES OF CLOTHING CONTAINING SOIL RETARDANTS; PREPARATIONS FOR DEGREASING AND REMOVAL OF WAX, OIL AND OTHER RESIDUES FROM FURNITURE, FLOORS AND OTHER HOUSEHOLD SURFACES, NAMELEY, DEGREASER AND REMOVER OF WAX, OIL AND OTHER RESIDUES FROM FURNITURE, FLOORS AND OTHER HOUSEHOLD SURFACES; CLEANING PREPARATIONS INCORPORATING SUBSTANCES FOR CONTROL OF ALLERGENS, NAMELY, HOUSEHOLD CLEANING PREPARATIONS INCORPORATING SUBSTANCES FOR CONTROL OF ALLERGENS, SPRAY-ON ANITI-MITE AND DEODORIZING CLEANING PREPARATIONS FOR MATTRESSES, UPHOLSTERY AND TEXTILES; CLEANING PREPARATIONS IMPREGNATED INTO GLOVES, RAGS, CLOTHS AND WIPES, ALL FOR USE IN CLEANING HOUSEHOLD SURFACES AND OBJECTS NAMELY HOUSEHOLD CLEANERS IMPREGNATED INTO GLOVES, RAGS, CLOTHS AND WIPES, ALL FOR USE IN CLEANING HOUSEHOLD SURFACES AND OBJECTS, IMPREGNATED WITH CHEMICALS OR COMPOUNDS FOR HOUSEHOLD USE, EXCEPT CHEMICALLY IMPREGNATED POLISHING GLOVES AND DISPOSABLE WIPES (U.S. CLS. 1, 4, 6, 50, 51 AND 52).

DAVID HOFFMAN, EXAMINING ATTORNEY

**CLASS 3—(Continued).**

SN 85-175,703. GIVE BACK BRANDS LLC, MARINA DEL REY, CA. FILED 11-12-2010.

# SOMEDAY

THE MARK CONSISTS OF STANDARD CHARACTERS WITHOUT CLAIM TO ANY PARTICULAR FONT, STYLE, SIZE, OR COLOR.  
FOR FRAGRANCES (U.S. CLS. 1, 4, 6, 50, 51 AND 52).  
DAVID COLLIER, EXAMINING ATTORNEY

---

SN 85-176,111. EXI INTERNATIONAL INC., FREELTON, ONTARIO, CANADA, FILED 11-13-2010.

# GELICIOUS

THE MARK CONSISTS OF STANDARD CHARACTERS WITHOUT CLAIM TO ANY PARTICULAR FONT, STYLE, SIZE, OR COLOR.  
FOR GEL FOR NAILS; NAIL GROOMING PRODUCTS, NAMELY, TIPS, GLUE, LACQUER AND GLITTER; NAIL POLISH (U.S. CLS. 1, 4, 6, 50, 51 AND 52).  
DOUGLAS LEE, EXAMINING ATTORNEY

---

SN 85-176,320. CRUZ, KAREN M., SAN DIEGO, CA. FILED 11-14-2010.

# SPRAVE

THE MARK CONSISTS OF STANDARD CHARACTERS WITHOUT CLAIM TO ANY PARTICULAR FONT, STYLE, SIZE, OR COLOR.  
FOR SHAVING SPRAY PREPARATION CONTAINING MINERAL OIL (U.S. CLS. 1, 4, 6, 50, 51 AND 52).  
DOMINIC FATHY, EXAMINING ATTORNEY

**CLASS 3—(Continued).**

SN 85-176,449. THE YANKEE CANDLE COMPANY, INC., SOUTH DEERFIELD, MA. FILED 11-15-2010.

# AUTUMN LEAVES

THE MARK CONSISTS OF STANDARD CHARACTERS WITHOUT CLAIM TO ANY PARTICULAR FONT, STYLE, SIZE, OR COLOR.  
FOR ELECTRIC FRAGRANCE DISPENSER REFILLS; ROOM FRAGRANCES; HOME FRAGRANCE OILS (U.S. CLS. 1, 4, 6, 50, 51 AND 52).  
FIRST USE 6-6-2006; IN COMMERCE 8-17-2006.  
HANNO RITTNER, EXAMINING ATTORNEY

---

SN 85-176,605. PARACAS LLC, NEW YORK, NY. FILED 11-15-2010.

# Everelle

THE MARK CONSISTS OF STANDARD CHARACTERS WITHOUT CLAIM TO ANY PARTICULAR FONT, STYLE, SIZE, OR COLOR.  
FOR ANTI-AGING CREAM; ANTI-WRINKLE CREAM (U.S. CLS. 1, 4, 6, 50, 51 AND 52).  
CURTIS FRENCH, EXAMINING ATTORNEY

---

SN 85-176,608. ORTEGA, MARGARITA, ELMHURST, NY. FILED 11-15-2010.

# MARVAUS CONCEPTS

THE MARK CONSISTS OF STANDARD CHARACTERS WITHOUT CLAIM TO ANY PARTICULAR FONT, STYLE, SIZE, OR COLOR.  
FOR COSMETICS (U.S. CLS. 1, 4, 6, 50, 51 AND 52).  
CURTIS FRENCH, EXAMINING ATTORNEY

**CLASS 3—(Continued).**

SN 85-177,186. BACK COUNTRY SOAPS, LLC, CAMPBELLSVILLE, KY. FILED 11-15-2010.

## Back Country Soaps

THE MARK CONSISTS OF STANDARD CHARACTERS WITHOUT CLAIM TO ANY PARTICULAR FONT, STYLE, SIZE, OR COLOR.

NO CLAIM IS MADE TO THE EXCLUSIVE RIGHT TO USE "SOAPS", APART FROM THE MARK AS SHOWN.

FOR BAR SOAP; BATH SOAPS; SHAVING SOAP (U.S. CLS. 1, 4, 6, 50, 51 AND 52).

FIRST USE 11-26-2004; IN COMMERCE 11-26-2004.  
CHRISTINE COOPER, EXAMINING ATTORNEY

**CLASS 3—(Continued).**

SN 85-177,942. JOCOTT BRANDS, INC., VAN NUYS, CA. FILED 11-16-2010.

## ARGANMAGIC

THE MARK CONSISTS OF STANDARD CHARACTERS WITHOUT CLAIM TO ANY PARTICULAR FONT, STYLE, SIZE, OR COLOR.

FOR NON-MEDICATED PREPARATIONS ALL FOR THE CARE OF SKIN, HAIR AND SCALP (U.S. CLS. 1, 4, 6, 50, 51 AND 52).

FRED CARL, EXAMINING ATTORNEY

SN 85-177,822. ADELE LLC., MEMPHIS, TN. FILED 11-16-2010.

## ILUDE

THE MARK CONSISTS OF STANDARD CHARACTERS WITHOUT CLAIM TO ANY PARTICULAR FONT, STYLE, SIZE, OR COLOR.

FOR ANTI-AGING CREAM; ANTI-WRINKLE CREAMS (U.S. CLS. 1, 4, 6, 50, 51 AND 52).

FIRST USE 9-30-2010; IN COMMERCE 10-25-2010.  
GEORGE LORENZO, EXAMINING ATTORNEY

SN 85-178,228. RAG & BONE HOLDINGS, LLC, NEW YORK, NY. FILED 11-16-2010.

## RAG & BONE

SN 85-177,930. JOCOTT BRANDS, INC., VAN NUYS, CA. FILED 11-16-2010.

## ARGANRITUALS

THE MARK CONSISTS OF STANDARD CHARACTERS WITHOUT CLAIM TO ANY PARTICULAR FONT, STYLE, SIZE, OR COLOR.

FOR NON-MEDICATED PREPARATIONS ALL FOR THE CARE OF SKIN, HAIR AND SCALP (U.S. CLS. 1, 4, 6, 50, 51 AND 52).

FRED CARL, EXAMINING ATTORNEY

THE MARK CONSISTS OF STANDARD CHARACTERS WITHOUT CLAIM TO ANY PARTICULAR FONT, STYLE, SIZE, OR COLOR.

OWNER OF U.S. REG. NOS. 2,906,967 AND 3,755,755.

FOR COSMETICS, NAMELY, PERFUME, COLOGNE, AFTERSHAVE BALM AND LOTION, SKIN CREAM, HAIR GEL, HAIR LOTION, BATH AND SHOWER GEL, SOAPS, SHAMPOO, HAIR-CONDITIONER, MAKEUP, NAMELY LIPSTICK, LIP GLOSS, FACIAL POWDER, MASCARA, EYESHADOW (U.S. CLS. 1, 4, 6, 50, 51 AND 52).

GEORGE LORENZO, EXAMINING ATTORNEY

**CLASS 3—(Continued).**

SN 85-178,232. LOTUS DISTRIBUTORS PTY. LTD., MORTDALE, NWS 2223, AUSTRALIA, FILED 11-16-2010.



THE MARK CONSISTS OF FLOWER DESIGN.  
FOR BABY OIL; BATH SOAPS IN LIQUID, SOLID OR GEL FORM; BODY CREAM SOAP; BODY POWDER; COSMETICS; DENTIFRICE; HAIR CARE LOTIONS; HAND SOAPS; LIQUID SOAPS FOR HANDS, FACE AND BODY; PERFUME; PETROLEUM JELLY FOR COSMETIC PURPOSES; SKIN AND BODY TOPICAL LOTIONS, CREAMS AND OILS FOR COSMETIC USE (U.S. CLS. 1, 4, 6, 50, 51 AND 52).

FIRST USE 11-10-1997; IN COMMERCE 11-10-1997.  
RONALD MCMORROW, EXAMINING ATTORNEY

SN 85-178,515. CELLULAR BIOENGINEERING, INC., HONOLULU, HI. FILED 11-17-2010.

# PRESTOR

THE MARK CONSISTS OF STANDARD CHARACTERS WITHOUT CLAIM TO ANY PARTICULAR FONT, STYLE, SIZE, OR COLOR.

FOR SKIN CLEANSERS; HAIR CLEANSERS; CLEANING PREPARATIONS FOR REMOVAL OF PARTICULATE CONTAMINANTS FROM SKIN AND HAIR; CLEANING PREPARATIONS FOR REMOVAL OF BIOLOGICAL, CHEMICAL, RADIOLOGICAL, RADIOACTIVE, AND NUCLEAR MATERIAL FROM SKIN AND HAIR; CLEANING PREPARATIONS FOR NEUTRALIZING AND DECONTAMINATING BIOLOGICAL, CHEMICAL, RADIOLOGICAL, RADIOACTIVE, AND NUCLEAR MATERIAL AND OTHER CONTAMINANTS; CLEANING PREPARATIONS FOR REMOVAL OF RADIOACTIVE PARTICLES FROM SURFACES; CLEANING PREPARATIONS FOR REMOVAL OF BIOLOGICAL, CHEMICAL, RADIOLOGICAL, RADIOACTIVE, AND NUCLEAR MATERIAL FROM TEXTILES AND CLOTHING (U.S. CLS. 1, 4, 6, 50, 51 AND 52).

RENEE MCCRAY, EXAMINING ATTORNEY

**CLASS 3—(Continued).**

SN 85-178,787. UBIQUITY PARTNERS, LLC, GARLAND, TX. FILED 11-17-2010.

# EIRO

THE MARK CONSISTS OF STANDARD CHARACTERS WITHOUT CLAIM TO ANY PARTICULAR FONT, STYLE, SIZE, OR COLOR.

OWNER OF U.S. REG. NO. 3,656,259.  
FOR NON-MEDICATED SKIN CARE PREPARATIONS (U.S. CLS. 1, 4, 6, 50, 51 AND 52).  
FIRST USE 8-13-2010; IN COMMERCE 10-15-2010.  
KATHERINE STOIDES, EXAMINING ATTORNEY

SN 85-178,931. INTERMEDIA U.S.A., INC., POMPANO BEACH, FL. FILED 11-17-2010.

# WIZARD

THE MARK CONSISTS OF STANDARD CHARACTERS WITHOUT CLAIM TO ANY PARTICULAR FONT, STYLE, SIZE, OR COLOR.

FOR INCENSE (U.S. CLS. 1, 4, 6, 50, 51 AND 52).  
DORITT L. CARROLL, EXAMINING ATTORNEY

SN 85-179,090. MAID GREEN LLC, HARVEST, AL. FILED 11-17-2010.

THE MARK CONSISTS OF "PROGREEN" IN STYLIZED LETTERS WITH SHADING.

FOR ALL-PURPOSE CLEANERS; DISH DETERGENTS; GLASS CLEANERS; LAUNDRY DETERGENTS; METAL POLISHING AND CLEANING PREPARATIONS; TOILET BOWL DETERGENTS (U.S. CLS. 1, 4, 6, 50, 51 AND 52).  
FIRST USE 10-0-2009; IN COMMERCE 10-0-2009.  
ERNEST SHOSHO, EXAMINING ATTORNEY

**CLASS 3—(Continued).**

SN 85-179,353. HATCH BEAUTY, LLC, SANTA MONICA, CA. FILED 11-17-2010.

## LUSH LOCKS

THE MARK CONSISTS OF STANDARD CHARACTERS WITHOUT CLAIM TO ANY PARTICULAR FONT, STYLE, SIZE, OR COLOR.

FOR 3-IN-1 HAIR CONDITIONERS; 3-IN-1 HAIR SHAMPOOS; BABY HAIR CONDITIONER; COSMETIC HAIR DRESSING PREPARATIONS; COSMETIC PREPARATIONS FOR THE HAIR AND SCALP; EXFOLIANTS FOR HAIR; GEL FOR HAIR; HAIR CARE LOTIONS; HAIR CLEANING PREPARATIONS; HAIR COLOR REMOVERS; HAIR COLORANTS; HAIR COLORING PREPARATIONS; HAIR COLOURANTS; HAIR COLOURING; HAIR COLOURING PREPARATIONS; HAIR CONDITIONER; HAIR CONDITIONERS; HAIR CONDITIONERS FOR BABIES; HAIR CURLING PREPARATIONS; HAIR DRESSINGS FOR MEN; HAIR DRESSINGS FOR WOMEN; HAIR FIXERS; HAIR GEL; HAIR GEL AND HAIR MOUSSE; HAIR GELS; HAIR GLAZE; HAIR LACQUERS; HAIR MASKS; HAIR MOUSSE; HAIR MOUSSES; HAIR NOURISHERS; HAIR OILS; HAIR POMADES; HAIR PRODUCTS, NAMELY, THICKENING CONTROL CREAMS; HAIR RELAXERS; HAIR RINSES; HAIR SHAMPOO; HAIR SHAMPOOS AND CONDITIONERS; HAIR SHEEN SPRAY; HAIR SPRAY; HAIR SPRAYS; HAIR SPRAYS AND HAIR GELS; HAIR STYLING GEL; HAIR STYLING PREPARATIONS; HAIR STYLING SPRAY; JAPANESE HAIR FIXING OIL (BINTSUKU-ABURA); NON-MEDICATED HAIR SERUMS; NON-MEDICATED HAIR TREATMENT PREPARATIONS FOR COSMETIC PURPOSES; NON-MEDICATED PREPARATIONS ALL FOR THE CARE OF SKIN, HAIR AND SCALP; NON-MEDICATED SERUMS FOR USE ON HAIR; OILS FOR HAIR CONDITIONING; PREPARATIONS FOR SETTING HAIR; STYLING FOAM FOR HAIR; STYLING PASTE FOR HAIR (U.S. CLS. 1, 4, 6, 50, 51 AND 52).

DOMINIC J. FERRAIUOLO, EXAMINING ATTORNEY

**CLASS 3—(Continued).**

SN 85-180,116. NEW YORK STATE DEPARTMENT OF ECONOMIC DEVELOPMENT, ALBANY, NY. FILED 11-18-2010.



OWNER OF U.S. REG. NOS. 1,558,379, 3,097,782 AND OTHERS.

THE COLOR(S) BLACK AND RED IS/ARE CLAIMED AS A FEATURE OF THE MARK.

THE MARK CONSISTS OF THE CHARACTERS "I" AND "NY" IN BLACK AND A HEART IN RED.

FOR PERFUMES, COLOGNES, COSMETICS (U.S. CLS. 1, 4, 6, 50, 51 AND 52).

JOHN E. MICHOS, EXAMINING ATTORNEY

SN 85-180,361. MLA MULTIBRAND HOLDINGS, INC., VERNON, CA. FILED 11-18-2010.

SN 85-180,013. NEW YORK STATE DEPARTMENT OF ECONOMIC DEVELOPMENT, ALBANY, NY. FILED 11-18-2010.



OWNER OF U.S. REG. NOS. 1,555,836, 3,097,782 AND OTHERS.

THE COLOR(S) BLACK AND RED IS/ARE CLAIMED AS A FEATURE OF THE MARK.

THE MARK CONSISTS OF THE CHARACTERS "I" AND "NY" IN BLACK AND A HEART IN RED.

FOR PERFUMES, COLOGNES, COSMETICS (U.S. CLS. 1, 4, 6, 50, 51 AND 52).

JOHN E. MICHOS, EXAMINING ATTORNEY

## Twelve Two

THE MARK CONSISTS OF STANDARD CHARACTERS WITHOUT CLAIM TO ANY PARTICULAR FONT, STYLE, SIZE, OR COLOR.

FOR TOILETRIES, NAMELY, PERFUMES, COLOGNES AND EAUX DE TOILETTE, SCENTED BODY SPRAY, PERFUME OILS, BODY LOTIONS, SHAMPOOS, HAIR CONDITIONERS, BATH OILS AND SALTS, BATH SOAPS, BATH GELS, BUBBLE BATH, SKIN SOAP, BODY OIL, BODY POWDER, SKIN MOISTURIZERS, BODY AND EYE CREAM, AND COSMETICS, NAMELY, MASCARAS, LIPSTICKS, LIP GLOSSES, COSMETIC PENCILS, EYE PENCILS, EYE SHADOWS, EYELINERS, EYE MAKE UP REMOVER, FOUNDATION, FACE POWDER, BLUSHER, HAIR GEL AND HAIR STYLING PREPARATIONS, NAIL ENAMEL, NAIL POLISH, AND POTPOURRI (U.S. CLS. 1, 4, 6, 50, 51 AND 52).

LAURA KOVALSKY, EXAMINING ATTORNEY



**CLASS 3—(Continued).**

SN 85-180,486. MLA MULTIBRAND HOLDINGS, INC., VERNON, CA. FILED 11-18-2010.

12-2

THE MARK CONSISTS OF STANDARD CHARACTERS WITHOUT CLAIM TO ANY PARTICULAR FONT, STYLE, SIZE, OR COLOR.

FOR TOILETRIES, NAMELY, PERFUMES, COLOGNES AND EAUX DE TOILETTE, SCENTED BODY SPRAY, PERFUME OILS, BODY LOTIONS, SHAMPOOS, HAIR CONDITIONERS, BATH OILS AND SALTS, BATH SOAPS, BATH GELS, BUBBLE BATH, SKIN SOAP, BODY OIL, BODY POWDER, SKIN MOISTURIZERS, BODY AND EYE CREAM, AND COSMETICS, NAMELY, MASCARAS, LIPSTICKS, LIP GLOSSES, COSMETIC PENCILS, EYE PENCILS, EYE SHADOWS, EYELINERS, EYE MAKE UP REMOVER, FOUNDATION, FACE POWDER, BLUSHER, HAIR GEL AND HAIR STYLING PREPARATIONS, NAIL ENAMEL, NAIL POLISH, AND POTPOURRI (U.S. CLS. 1, 4, 6, 50, 51 AND 52).  
LAURA KOVALSKY, EXAMINING ATTORNEY

**CLASS 3—(Continued).**

SN 85-181,233. UNITED LABORATORIES, INC., ST. CHARLES, IL. FILED 11-19-2010.

BIO-RENETICS

THE MARK CONSISTS OF STANDARD CHARACTERS WITHOUT CLAIM TO ANY PARTICULAR FONT, STYLE, SIZE, OR COLOR.

FOR SPECIALTY CLEANING PRODUCTS, NAMELY, CLEANING PREPARATIONS AND ALL PURPOSE CLEANERS AND DEGREASERS FOR THE REMOVAL OF SLIME, MASTICS, ADHESIVES, VEGETABLE AND PETROLEUM DERIVED GREASES AND OILS AND OTHER CONTAMINANTS FROM NATURAL AND MAN MADE SURFACES, NAMELY, SOIL, METAL AND CONCRETE AND EXCLUDING DEGREASERS FOR MANUFACTURING; ADHESIVE REMOVERS; DEGREASING PREPARATIONS FOR HOUSEHOLD APPLICATIONS; SOLVENTS FOR CLEANING AND CONTAMINANT REMOVAL, NAMELY, CLEANING PREPARATIONS IN THE NATURE OF A SOLVENT FOR HOUSEHOLD USE (U.S. CLS. 1, 4, 6, 50, 51 AND 52).  
TARAH HARDY, EXAMINING ATTORNEY

SN 85-189,711. THE CLOROX COMPANY, OAKLAND, CA. FILED 12-2-2010.

SMARTBLEACH

THE MARK CONSISTS OF STANDARD CHARACTERS WITHOUT CLAIM TO ANY PARTICULAR FONT, STYLE, SIZE, OR COLOR.

FOR BLEACHING PREPARATIONS FOR HOUSEHOLD USE (U.S. CLS. 1, 4, 6, 50, 51 AND 52).  
AMY ALFIERI, EXAMINING ATTORNEY

SN 85-181,094. R.U.T. 13, LLC, MATTHEWS, NC. FILED 11-19-2010.

R.U.T. 13

SN 85-191,443. WESTERN HOLDINGS, LLC, CARSON CITY, NV. FILED 12-6-2010.

ACTIVE COLOR

THE MARK CONSISTS OF STANDARD CHARACTERS WITHOUT CLAIM TO ANY PARTICULAR FONT, STYLE, SIZE, OR COLOR.

FOR HAIR CARE CREAMS; HAIR GELS; HAIR SHAMPOOS AND CONDITIONERS; HAIR SPRAY; HAIR TONICS; HAIR WAX; NON-MEDICATED HAIR SERUMS; NON-MEDICATED HAIR TREATMENT PREPARATIONS FOR COSMETIC PURPOSES; STYLING PASTE FOR HAIR (U.S. CLS. 1, 4, 6, 50, 51 AND 52).  
LINDA E. BLOHM, EXAMINING ATTORNEY

THE MARK CONSISTS OF STANDARD CHARACTERS WITHOUT CLAIM TO ANY PARTICULAR FONT, STYLE, SIZE, OR COLOR.

NO CLAIM IS MADE TO THE EXCLUSIVE RIGHT TO USE "COLOR", APART FROM THE MARK AS SHOWN. FOR COSMETICS (U.S. CLS. 1, 4, 6, 50, 51 AND 52).  
TASNEEM HUSSAIN, EXAMINING ATTORNEY

**CLASS 3—(Continued).**

SN 85-191,471. OASIS BRANDS, INC., WINCHESTER, VA. FILED 12-6-2010.

**STAY BRIGHT**

THE MARK CONSISTS OF STANDARD CHARACTERS WITHOUT CLAIM TO ANY PARTICULAR FONT, STYLE, SIZE, OR COLOR.

FOR BABY LOTION; BABY SHAMPOO; BABY WIPES; CLEANING PREPARATIONS FOR CLEANING SURFACES; CLEANING PREPARATIONS FOR HOUSEHOLD PURPOSES; CLEANING, SCOURING AND POLISHING PREPARATIONS AND SUBSTANCES; CLOTHS IMPREGNATED WITH A DETERGENT FOR CLEANING; HAIR CONDITIONERS FOR BABIES; PRE-MOISTENED COSMETIC WIPES; SOAPS FOR HOUSEHOLD USE; SOAPS FOR TOILET PURPOSES; WIPES IMPREGNATED WITH A SKIN CLEANSER (U.S. CLS. 1, 4, 6, 50, 51 AND 52).

LINDSEY RUBIN, EXAMINING ATTORNEY

SN 85-191,873. MARY KAY INC., ADDISON, TX. FILED 12-7-2010.

**TIMEWISE REPLENISHING  
SERUM + C**

THE MARK CONSISTS OF STANDARD CHARACTERS WITHOUT CLAIM TO ANY PARTICULAR FONT, STYLE, SIZE, OR COLOR.

OWNER OF U.S. REG. NOS. 2,414,631, 3,304,771 AND 3,440,537.

NO CLAIM IS MADE TO THE EXCLUSIVE RIGHT TO USE "REPLENISHING SERUM + C", APART FROM THE MARK AS SHOWN.

FOR COSMETICS; NON-MEDICATED SKIN CARE PREPARATIONS (U.S. CLS. 1, 4, 6, 50, 51 AND 52).

FIRST USE 7-16-2009; IN COMMERCE 8-26-2009.  
MICHAEL ENGEL, EXAMINING ATTORNEY

SN 85-196,895. V BEAUTE LLC, NEW YORK, NY. FILED 12-13-2010.

**NIGHT CAP**

THE MARK CONSISTS OF STANDARD CHARACTERS WITHOUT CLAIM TO ANY PARTICULAR FONT, STYLE, SIZE, OR COLOR.

FOR FACE CREAMS; INTENSIVE REPAIR NIGHT CREAM (U.S. CLS. 1, 4, 6, 50, 51 AND 52).

SUZANNE BLANE, EXAMINING ATTORNEY

**CLASS 3—(Continued).**

SN 85-197,055. MARY KAY INC., ADDISON, TX. FILED 12-14-2010.

**TIMEWISE MATTE-WEAR**

THE MARK CONSISTS OF STANDARD CHARACTERS WITHOUT CLAIM TO ANY PARTICULAR FONT, STYLE, SIZE, OR COLOR.

OWNER OF U.S. REG. NOS. 2,414,631, 3,304,771 AND 3,440,537.

FOR COSMETICS; MAKE UP FOUNDATIONS (U.S. CLS. 1, 4, 6, 50, 51 AND 52).

MICHAEL ENGEL, EXAMINING ATTORNEY

SN 85-198,291. WESTERN HOLDINGS, LLC, CARSON CITY, NV. FILED 12-15-2010.

**LIPID TRANSFER**

THE MARK CONSISTS OF STANDARD CHARACTERS WITHOUT CLAIM TO ANY PARTICULAR FONT, STYLE, SIZE, OR COLOR.

NO CLAIM IS MADE TO THE EXCLUSIVE RIGHT TO USE "LIPID", APART FROM THE MARK AS SHOWN.

FOR COSMETICS (U.S. CLS. 1, 4, 6, 50, 51 AND 52).

TASNEEM HUSSAIN, EXAMINING ATTORNEY

SN 85-206,314. MARY KAY INC., ADDISON, TX. FILED 12-28-2010.

**MARY KAY LASH & BROW  
BUILDING SERUM**

THE MARK CONSISTS OF STANDARD CHARACTERS WITHOUT CLAIM TO ANY PARTICULAR FONT, STYLE, SIZE, OR COLOR.

NO CLAIM IS MADE TO THE EXCLUSIVE RIGHT TO USE "LASH & BROW BUILDING SERUM", APART FROM THE MARK AS SHOWN.

"MARY KAY" DOES NOT IDENTIFY A LIVING INDIVIDUAL.

FOR COSMETICS; EYELASH AND EYEBROW CONDITIONER, EYELASH AND EYEBROW ENHANCER, EYELASH AND EYEBROW SERUM FOR CONDITIONING AND ENHANCING THE APPEARANCE OF EYELASHES AND EYEBROWS (U.S. CLS. 1, 4, 6, 50, 51 AND 52).

MICHAEL ENGEL, EXAMINING ATTORNEY

**CLASS 3—(Continued).**

SN 85-206,318. MARY KAY INC., ADDISON, TX. FILED 12-28-2010.

**MARY KAY PANTHENOL-PRO  
COMPLEX**

THE MARK CONSISTS OF STANDARD CHARACTERS WITHOUT CLAIM TO ANY PARTICULAR FONT, STYLE, SIZE, OR COLOR.

NO CLAIM IS MADE TO THE EXCLUSIVE RIGHT TO USE "COMPLEX", APART FROM THE MARK AS SHOWN.

"MARY KAY" DOES NOT IDENTIFY A LIVING INDIVIDUAL.

FOR COSMETICS; EYELASH AND EYEBROW CONDITIONER, EYELASH AND EYEBROW ENHANCER, EYELASH AND EYEBROW SERUM FOR CONDITIONING AND ENHANCING THE APPEARANCE OF EYELASHES AND EYEBROWS (U.S. CLS. 1, 4, 6, 50, 51 AND 52).

MICHAEL ENGEL, EXAMINING ATTORNEY

**CLASS 3—(Continued).**

SN 85-213,784. SHISEIDO COMPANY, LTD., TOKYO, JAPAN, FILED 1-10-2011.

**REVITAL  
LOTION EX**

*SHISEIDO*

SN 85-206,319. MARY KAY INC., ADDISON, TX. FILED 12-28-2010.

**MARY KAY LASH BUILDING  
SERUM**

THE MARK CONSISTS OF STANDARD CHARACTERS WITHOUT CLAIM TO ANY PARTICULAR FONT, STYLE, SIZE, OR COLOR.

NO CLAIM IS MADE TO THE EXCLUSIVE RIGHT TO USE "LASH BUILDING SERUM", APART FROM THE MARK AS SHOWN.

"MARY KAY" DOES NOT IDENTIFY A LIVING INDIVIDUAL.

FOR COSMETICS; EYELASH CONDITIONER, EYELASH ENHANCER, EYELASH SERUM FOR CONDITIONING AND ENHANCING THE APPEARANCE OF EYELASHES (U.S. CLS. 1, 4, 6, 50, 51 AND 52).

MICHAEL ENGEL, EXAMINING ATTORNEY

OWNER OF U.S. REG. NOS. 686,446, 3,216,053 AND OTHERS.

NO CLAIM IS MADE TO THE EXCLUSIVE RIGHT TO USE "LOTION", APART FROM THE MARK AS SHOWN.

THE MARK CONSISTS OF THE WORDS "REVITAL LOTION EX SHISEIDO" IN STYLIZED LETTERING.

FOR NON-MEDICATED SKIN CARE PREPARATIONS FOR THE FACE (U.S. CLS. 1, 4, 6, 50, 51 AND 52).

ERNEST SHOSHO, EXAMINING ATTORNEY

SN 85-213,234. SPARTAN BRANDS, INC., NEW YORK, NY. FILED 1-7-2011.

**FIX**

THE MARK CONSISTS OF STANDARD CHARACTERS WITHOUT CLAIM TO ANY PARTICULAR FONT, STYLE, SIZE, OR COLOR.

FOR HAIR CONDITIONERS, SHAMPOOS, AND HAIR FIXATIVES (U.S. CLS. 1, 4, 6, 50, 51 AND 52).

HOWARD SMIGA, EXAMINING ATTORNEY

SN 85-213,885. SUNKIST GROWERS, INC., SHERMAN OAKS, CA. FILED 1-10-2011.

**SUNKIST**

THE MARK CONSISTS OF STANDARD CHARACTERS WITHOUT CLAIM TO ANY PARTICULAR FONT, STYLE, SIZE, OR COLOR.

OWNER OF U.S. REG. NOS. 72,087, 267,936 AND OTHERS. FOR LIP BALM (U.S. CLS. 1, 4, 6, 50, 51 AND 52).

REBECCA POVARCHUK, EXAMINING ATTORNEY

**CLASS 3—(Continued).**

SN 85-214,074. SHISEIDO COMPANY, LTD., TOKYO, JAPAN, FILED 1-10-2011.

REVITAL  
MOISTURIZER EX

SHISEIDO

OWNER OF U.S. REG. NOS. 686,446, 3,216,053 AND OTHERS.

NO CLAIM IS MADE TO THE EXCLUSIVE RIGHT TO USE "MOISTURIZER", APART FROM THE MARK AS SHOWN.

THE MARK CONSISTS OF THE WORDS "REVITAL MOISTURIZER EX SHISEIDO" IN STYLIZED LETTERING. FOR NON-MEDICATED SKIN CARE PREPARATIONS FOR THE FACE (U.S. CLS. 1, 4, 6, 50, 51 AND 52).

ERNEST SHOSHO, EXAMINING ATTORNEY

SN 85-216,904. SPARTAN BRANDS, INC., NEW YORK, NY. FILED 1-13-2011.

NEVR DRY

THE MARK CONSISTS OF STANDARD CHARACTERS WITHOUT CLAIM TO ANY PARTICULAR FONT, STYLE, SIZE, OR COLOR.

FOR HAIR OIL (U.S. CLS. 1, 4, 6, 50, 51 AND 52). HOWARD SMIGA, EXAMINING ATTORNEY

SN 85-217,018. MAKE-UP ART COSMETICS INC., NEW YORK, NY. FILED 1-13-2011.

AIR OF STYLE

THE MARK CONSISTS OF STANDARD CHARACTERS WITHOUT CLAIM TO ANY PARTICULAR FONT, STYLE, SIZE, OR COLOR.

FOR FRAGRANCES FOR PERSONAL USE (U.S. CLS. 1, 4, 6, 50, 51 AND 52). FIRST USE 11-30-2007; IN COMMERCE 11-30-2007. SUSAN RICHARDS, EXAMINING ATTORNEY

**CLASS 3—(Continued).**

SN 85-223,027. SALES & PRODUCT SOLUTIONS, INC., NORTHBROOK, IL. FILED 1-21-2011.

KISS ME KATE

THE MARK CONSISTS OF STANDARD CHARACTERS WITHOUT CLAIM TO ANY PARTICULAR FONT, STYLE, SIZE, OR COLOR.

FOR BATH AND BODY CARE PRODUCTS AND ACCESSORIES, NAMELY, HOT AND COLD REUSABLE EYE COMPRESSES FOR BEAUTY AND COSMETIC USES, COSMETICS, COSMETIC PADS, BATH BEADS, BATH CREAM, BATH CRYSTALS, BATH FIZZIES, BATH FLAKES, BATH FOAM, BATH GELS, BATH LOTION, BATH MILK, BATH OIL, BATH OILS AND BATH SALTS, BATH PEARLS, BATH POWDER, NON-MEDICATED BATH SALTS, BATH SOAPS, BATH SOAPS IN LIQUID, SOLID OR GEL FORM, BUBBLE BATH, FOAM BATH, SOAP USED IN FOOT BATHS, NON-MEDICATED BATH PREPARATIONS, SHOWER AND BATH FOAM, SHOWER AND BATH GEL, BODY SPRAY, SKIN SOAPS, BODY WASHES, NON-MEDICATED SKIN CARE PREPARATIONS, NAMELY, BODY MIST, HAND SOAPS, HAND LOTION, SKIN CREAMS, BODY LOTIONS, BODY SCRUB, FOOT SCRUB, NON-MEDICATED FOOT LOTION, NON-MEDICATED FOOT SOAK, PUMICE STONES FOR PERSONAL USE, BODY BUTTER, SHEA BUTTER FOR COSMETIC PURPOSES (U.S. CLS. 1, 4, 6, 50, 51 AND 52).

SUSAN STIGLITZ, EXAMINING ATTORNEY

SN 85-225,623. JAFRA COSMETICS INTERNATIONAL, INC., WESTLAKE VILLAGE, CA. FILED 1-25-2011.

ROYAL ROSE

THE MARK CONSISTS OF STANDARD CHARACTERS WITHOUT CLAIM TO ANY PARTICULAR FONT, STYLE, SIZE, OR COLOR.

OWNER OF U.S. REG. NO. 2,851,459. NO CLAIM IS MADE TO THE EXCLUSIVE RIGHT TO USE "ROSE", APART FROM THE MARK AS SHOWN. FOR BATH AND SHOWER GEL; BODY OIL; AND BODY LOTION (U.S. CLS. 1, 4, 6, 50, 51 AND 52). FIRST USE 1-1-2005; IN COMMERCE 1-1-2005. SIMON TENG, EXAMINING ATTORNEY

**CLASS 4—LUBRICANTS AND FUELS**

SN 85-006,833. CROSS OIL REFINING & MARKETING, INC., SMACKOVER, AR. FILED 4-5-2010.



OWNER OF U.S. REG. NO. 3,892,958.  
THE MARK CONSISTS OF THE LITERAL ELEMENT "CROSS" AND FANCIFUL OIL DROP DESIGN TO THE RIGHT OF THE LITERAL ELEMENT, THE OIL DROP DESIGN IN GRAY REPRESENTING SHADING, AND THE DROP DESIGN PRESENTED ON A SHADED RECTANGULAR BACKGROUND.

FOR NAPHTHENIC OILS AND PROCESS AND BASE OILS USED IN THE MANUFACTURE OF LUBRICANTS, METAL WORKING FLUIDS, GREASES, RUBBERS, ADHESIVES AND EXTENDERS, ELECTRICAL TRANSFORMER OILS, ROOFING AND ROAD PAVING MATERIALS AND NEWS INK (U.S. CLS. 1, 6 AND 15).  
FIRST USE 0-0-1992; IN COMMERCE 0-0-1992.  
HELENE LIWINSKI, EXAMINING ATTORNEY

SN 85-006,904. SUMMIT ENTERTAINMENT, LLC, SANTA MONICA, CA. FILED 4-6-2010.



THE MARK CONSISTS OF A CIRCULAR TRIBAL TATTOO DESIGN DEPICTING TWO WOLVES FACING ONE ANOTHER IN A HOWLING POSITION, SET AMONGST NUMEROUS INTERWOVEN LINES AND SHAPES AND ALL WITHIN THE CIRCLE.  
FOR CANDLES; LAMP OILS (U.S. CLS. 1, 6 AND 15).  
FIRST USE 11-0-2009; IN COMMERCE 11-0-2009.  
TRACY FLETCHER, EXAMINING ATTORNEY

**CLASS 4—(Continued).**

SN 85-007,146. BEARING DISTRIBUTORS, INC., CLEVELAND, OH. FILED 4-6-2010.



THE MARK CONSISTS OF THE WORD "SMARTLUBE" IN STYLIZED FONT, WITH A CAPITAL "S" FOLLOWED BY "MART" IN LOWER CASE LETTERS, FOLLOWED BY "LUBE" IN UPPER CASE LETTERS, ALL SHOWN TO THE RIGHT OF A CURVED ARC.  
FOR LUBRICANTS, NAMELY, OILS, GREASES, FLUIDS AND GRAPHITE FOR THE PURPOSES OF LUBRICATION AND CORROSION PROTECTION OF MECHANICAL EQUIPMENT (U.S. CLS. 1, 6 AND 15).  
ESTHER BELENKER, EXAMINING ATTORNEY

SN 85-081,105. ROSEMEAD OIL PRODUCTS, INC., DBA ROSEMEAD OIL PRODUCTS, INC., SANTA FE SPRINGS, CA. FILED 7-9-2010.



NO CLAIM IS MADE TO THE EXCLUSIVE RIGHT TO USE "OIL", APART FROM THE MARK AS SHOWN.  
THE COLOR(S) GREEN AND GREY IS/ARE CLAIMED AS A FEATURE OF THE MARK.  
THE MARK CONSISTS OF THE WORDS "SMART OIL" IN THE COLORS GREEN AND GREY. THE WORD "SMART" IN GREEN AND THE WORD "OIL" IN GREY.  
FOR LUBRICATING OILS; MOTOR OIL; MOTOR OILS (U.S. CLS. 1, 6 AND 15).  
LINDA M. KING, EXAMINING ATTORNEY

SN 85-094,518. ECOLAB USA INC., SAINT PAUL, MN. FILED 7-28-2010.



THE MARK CONSISTS OF STANDARD CHARACTERS WITHOUT CLAIM TO ANY PARTICULAR FONT, STYLE, SIZE, OR COLOR.  
OWNER OF U.S. REG. NOS. 1,497,423, 1,538,458 AND OTHERS.  
FOR CONVEYOR LUBRICANTS; FOOD GRADE LUBRICANT FOR FOOD PROCESSING EQUIPMENT; GRANULAR ABSORBENT ORGANIC MINERAL-BASED COMPOSITIONS USED TO ABSORB LIQUID SPILLS; INDUSTRIAL LUBRICANTS; LUBRICANT FOR SURGICAL INSTRUMENTS; LUBRICANTS FOR RAILS, SHACKLES AND TROLLEYS (U.S. CLS. 1, 6 AND 15).  
FIRST USE 7-31-1987; IN COMMERCE 7-31-1987.  
BRENDAN REGAN, EXAMINING ATTORNEY

**CLASS 4—(Continued).**

SN 85-152,733. PETER J. WYCKOFF, DBA BEST OF THE WEST TWO TREES PRODUCTS, SUNLAND, CA. FILED 10-14-2010.

**TURBOFLAME**

THE MARK CONSISTS OF STANDARD CHARACTERS WITHOUT CLAIM TO ANY PARTICULAR FONT, STYLE, SIZE, OR COLOR.

FOR GAS FIRE STARTERS AS FUEL FOR COOKING, FOR BARBEQUES, FOR CAMPFIRES, FOR CHARCOAL, AND FOR FIREPLACES (U.S. CLS. 1, 6 AND 15).  
ANDREW LEASER, EXAMINING ATTORNEY

**CLASS 4—(Continued).**

SN 85-176,890. SUPREME BRANDS INC., MONTCLAIR, NJ. FILED 11-15-2010.

**LOVE MY HOME**

THE MARK CONSISTS OF STANDARD CHARACTERS WITHOUT CLAIM TO ANY PARTICULAR FONT, STYLE, SIZE, OR COLOR.

FOR CANDLES (U.S. CLS. 1, 6 AND 15).  
JORDAN BAKER, EXAMINING ATTORNEY

SN 85-154,807. WERC-2, INC., BOURNE, MA. FILED 10-18-2010.



NO CLAIM IS MADE TO THE EXCLUSIVE RIGHT TO USE "INC.", APART FROM THE MARK AS SHOWN.

THE MARK CONSISTS OF THE STYLIZED ALPHANUMERIC ELEMENTS "ECO TAC WERC-2, INC." AND THE DESIGN ELEMENT CONTAINING THE LETTER "W" INSIDE A CIRCLE, WITHIN ANOTHER CIRCLE, WHICH HAS SIX SMALL CIRCLES ALONG THE CIRCUMFERENCE, EACH CONTAINING LINES CONNECTING BACK TO THE CENTRAL CIRCLE, AND ALL OF THE FOREMENTIONED ELEMENTS ARE WITHIN AN OVAL CARRIER DESIGN.

FOR FUELS (U.S. CLS. 1, 6 AND 15).  
FIRST USE 10-1-2009; IN COMMERCE 4-1-2010.  
JUDITH HELFMAN, EXAMINING ATTORNEY

SN 85-183,472. CHAMPION BRANDS, LLC, CLINTON, MO. FILED 11-23-2010.

**BLUE FLAME**

THE MARK CONSISTS OF STANDARD CHARACTERS WITHOUT CLAIM TO ANY PARTICULAR FONT, STYLE, SIZE, OR COLOR.

FOR AUTOMOBILE LUBRICANTS; AUTOMOTIVE LUBRICANTS; LUBRICATING OIL FOR MOTOR VEHICLE ENGINES (U.S. CLS. 1, 6 AND 15).  
FIRST USE 1-26-2011; IN COMMERCE 1-26-2011.  
TOBY BULLOFF, EXAMINING ATTORNEY

SN 85-176,454. THE YANKEE CANDLE COMPANY, INC., SOUTH DEERFIELD, MA. FILED 11-15-2010.

**AUTUMN LEAVES**

THE MARK CONSISTS OF STANDARD CHARACTERS WITHOUT CLAIM TO ANY PARTICULAR FONT, STYLE, SIZE, OR COLOR.

FOR CANDLES; FRAGRANCED WAX FOR USE IN POTPOURRI BURNERS (U.S. CLS. 1, 6 AND 15).  
FIRST USE 5-25-2006; IN COMMERCE 6-6-2006.  
HANNO RITTNER, EXAMINING ATTORNEY

SN 85-229,748. KRINGLE CANDLE COMPANY LLC, BERNARDSTON, MA. FILED 1-31-2011.

**RAMEKIN KITCHEN**

THE MARK CONSISTS OF STANDARD CHARACTERS WITHOUT CLAIM TO ANY PARTICULAR FONT, STYLE, SIZE, OR COLOR.

FOR CANDLES (U.S. CLS. 1, 6 AND 15).  
B. PARADEWELAI, EXAMINING ATTORNEY

**CLASS 5—PHARMACEUTICALS**

SN 76-695,239. APOTEX TECHNOLOGIES INC., TORONTO, ONTARIO, CANADA, FILED 1-12-2009.

# METGLUTA

THE MARK CONSISTS OF STANDARD CHARACTERS WITHOUT CLAIM TO ANY PARTICULAR FONT, STYLE, SIZE, OR COLOR.

FOR ANTIDIABETIC PHARMACEUTICAL PREPARATIONS AND SUBSTANCES, NAMELY, PHARMACEUTICALS CONTAINING A BIGUANIDE ACTIVE INGREDIENT, NAMELY, METFORMIN, FOR THE TREATMENT OF DIABETES (U.S. CLS. 6, 18, 44, 46, 51 AND 52).

KHANH LE, EXAMINING ATTORNEY

SN 76-705,312. RETIEF SKIN CENTER, NASHVILLE, TN, FILED 11-12-2010.

# BUFFRX SKINCARE

THE MARK CONSISTS OF STANDARD CHARACTERS WITHOUT CLAIM TO ANY PARTICULAR FONT, STYLE, SIZE, OR COLOR.

NO CLAIM IS MADE TO THE EXCLUSIVE RIGHT TO USE "SKINCARE", APART FROM THE MARK AS SHOWN.

FOR PRESCRIPTION AND NON-PRESCRIPTION MEDICATED AND VITAMIN ENHANCED SKIN CARE PREPARATIONS, NAMELY, SKIN PEELS, SKIN SUNSCREENS, SKIN MEDICATIONS, SKIN TREATMENTS, SKIN DETOXES, SKIN CLEANSERS AND SKIN SCRUBS IN THE FORM OF PADS, GELS, FOAMING GELS, FOAMING WASHES, SOLIDS, ROLL-ONS, SCRUBS, POLISHERS, OINTMENTS, OILS, LOTIONS, SERUMS, LIQUIDS, CREMES, CHEMICAL PEELS, PEEL GELS, MICRODERMABRATIONS, CREME WASHES, GEL WASHES, CREAMS, TONERS, SPRAYS, WIPES, MASQUES, EMOLLIENTS, BALMS, COMPACTS, WATERS, SOLUTIONS, MINERAL POWDERS, PRIMERS, MISTS, IN THE FIELDS OF SKIN PEEL TREATMENT SYSTEMS, ACNE TREATMENT SYSTEMS, SUN PROTECTION TREATMENT SYSTEMS, SUNBURN TREATMENT SYSTEMS, HYPERPIGMENTED SKIN TREATMENT SYSTEMS, SKIN LIGHTENING TREATMENT SYSTEMS, CAPILLARY WALL STRENGTHENING TREATMENT SYSTEMS, VITAMIN ENHANCER SKIN TREATMENT SYSTEMS, SKIN HEALTH MAINTENANCE TREATMENT SYSTEMS, SKIN DETOXER TREATMENT SYSTEMS (U.S. CLS. 6, 18, 44, 46, 51 AND 52).

KHANH LE, EXAMINING ATTORNEY

**CLASS 5—(Continued).**

SN 76-705,349. ADAY, CHARLES B., NORTH LAS VEGAS, NV, FILED 11-16-2010.

# FORGIVEN

THE MARK CONSISTS OF STANDARD CHARACTERS WITHOUT CLAIM TO ANY PARTICULAR FONT, STYLE, SIZE, OR COLOR.

FOR DIETARY SUPPLEMENTS, NAMELY, ALCOHOL METABOLIZER PILLS (U.S. CLS. 6, 18, 44, 46, 51 AND 52).

FIRST USE 1-1-2010; IN COMMERCE 6-1-2010.

COLLEEN KEARNEY, EXAMINING ATTORNEY

SN 76-705,384. GARCOA, INC., CALABASAS, CA, FILED 11-15-2010.

# MD4 VITAMINS

THE MARK CONSISTS OF STANDARD CHARACTERS WITHOUT CLAIM TO ANY PARTICULAR FONT, STYLE, SIZE, OR COLOR.

NO CLAIM IS MADE TO THE EXCLUSIVE RIGHT TO USE "VITAMINS", APART FROM THE MARK AS SHOWN. FOR VITAMINS AND DIETARY FOOD SUPPLEMENTS (U.S. CLS. 6, 18, 44, 46, 51 AND 52).

FIRST USE 11-1-2010; IN COMMERCE 11-1-2010.

KAREN SEVERSON, EXAMINING ATTORNEY

SN 76-705,396. IMAGILIN TECHNOLOGY, LLC, FREDERICK, MD, FILED 11-18-2010.

# IMAGILIN

THE MARK CONSISTS OF STANDARD CHARACTERS WITHOUT CLAIM TO ANY PARTICULAR FONT, STYLE, SIZE, OR COLOR.

FOR NUTRITIONAL SUPPLEMENTS, NAMELY, PROBIOTIC COMPOSITIONS (U.S. CLS. 6, 18, 44, 46, 51 AND 52).

FIRST USE 11-15-2004; IN COMMERCE 11-15-2004.

ANTHONY RINKER, EXAMINING ATTORNEY

**CLASS 5—(Continued).**

SN 76-705,405. GREEK ISLAND LABS, LLC, SCOTTSDALE, AZ. FILED 11-19-2010.

**NATURALHEART**

THE MARK CONSISTS OF STANDARD CHARACTERS WITHOUT CLAIM TO ANY PARTICULAR FONT, STYLE, SIZE, OR COLOR.

FOR VITAMINS AND DIETARY SUPPLEMENTS (U.S. CLS. 6, 18, 44, 46, 51 AND 52).

FIRST USE 11-15-2010; IN COMMERCE 11-15-2010.  
SUE LAWRENCE, EXAMINING ATTORNEY

**CLASS 5—(Continued).**

SN 77-688,896. PRIMARY INVESTMENTS GROUP LIMITED, ROAD TOWN, TORTOLA, BR.VIRGIN ISLANDS, FILED 3-11-2009.

**ULTRA DELICIOUS FIBER SHOT**

THE MARK CONSISTS OF STANDARD CHARACTERS WITHOUT CLAIM TO ANY PARTICULAR FONT, STYLE, SIZE, OR COLOR.

NO CLAIM IS MADE TO THE EXCLUSIVE RIGHT TO USE "DELICIOUS FIBER SHOT", APART FROM THE MARK AS SHOWN.

FOR DIETARY SUPPLEMENTS CONTAINING FIBER; FOOD SUPPLEMENTS CONTAINING FIBER; NUTRITIONAL SUPPLEMENTS CONTAINING FIBER; DRINKS FOR USE AS MEAL REPLACEMENTS AND DIETARY MEAL SUPPLEMENT DRINK MIXES CONTAINING FIBER; DIETARY SUPPLEMENTS, NUTRITIONAL SUPPLEMENTS, AND MEAL REPLACEMENTS DRINKS CONTAINING FIBER (U.S. CLS. 6, 18, 44, 46, 51 AND 52).  
MATTHEW KLINE, EXAMINING ATTORNEY

SN 77-448,955. N.V.E., INC., ANDOVER, NJ. FILED 4-15-2008.

**THE BIG SHOT**

THE MARK CONSISTS OF STANDARD CHARACTERS WITHOUT CLAIM TO ANY PARTICULAR FONT, STYLE, SIZE, OR COLOR.

FOR VITAMINS, DIETARY AND NUTRITIONAL SUPPLEMENTS (U.S. CLS. 6, 18, 44, 46, 51 AND 52).

WILLIAM VERHOSEK, EXAMINING ATTORNEY

SN 77-746,783. MACROCURE, LTD., PETACH TIKVA, ISRAEL, FILED 5-28-2009.

SN 77-533,878. SIGMA-TAU INDUSTRIE FARMACEUTICHE RIUNITE S.P.A., ROMA, ITALY, FILED 7-29-2008.

**CARNICEUTICALS**

THE MARK CONSISTS OF STANDARD CHARACTERS WITHOUT CLAIM TO ANY PARTICULAR FONT, STYLE, SIZE, OR COLOR.

OWNER OF ERPN CMNTY TM OFC REG. NO. 001735059, DATED 7-3-2001, RENEWED AS REG. NO. 001735059, DATED 7-3-2010, EXPIRES 7-3-2020.

OWNER OF U.S. REG. NO. 2,614,351.

FOR NUTRACEUTICALS FOR USE AS A DIETARY SUPPLEMENT; DIETARY SUPPLEMENTS; AND FOOD SUPPLEMENTS (U.S. CLS. 6, 18, 44, 46, 51 AND 52).

DEZMONA MIZELLE, EXAMINING ATTORNEY

**CUREXCELL**

THE MARK CONSISTS OF STANDARD CHARACTERS WITHOUT CLAIM TO ANY PARTICULAR FONT, STYLE, SIZE, OR COLOR.

PRIORITY CLAIMED UNDER SEC. 44(D) ON ISRAEL APPLICATION NO. 220848, FILED 5-20-2009, REG. NO. 220848, DATED 10-12-2010, EXPIRES 5-20-2019.

FOR THERAPEUTIC PREPARATIONS, NAMELY, CELLULAR COMPOSITIONS FOR WOUND TREATMENT (U.S. CLS. 6, 18, 44, 46, 51 AND 52).

ANNE FARRELL, EXAMINING ATTORNEY



**CLASS 5—(Continued).**

SN 77-811,119. TOYAMA CHEMICAL CO., LTD, TOKYO, JAPAN, FILED 8-24-2009.

**CLASS 5—(Continued).**

SN 77-828,036. RON KUUS, TORONTO, ONTARIO, CANADA, FILED 9-16-2009.

**AVIGAN**

**Knock Down**

THE MARK CONSISTS OF STANDARD CHARACTERS WITHOUT CLAIM TO ANY PARTICULAR FONT, STYLE, SIZE, OR COLOR.

PRIORITY CLAIMED UNDER SEC. 44(D) ON JAPAN APPLICATION NO. 2009-63975, FILED 8-21-2009, REG. NO. 5313491, DATED 4-2-2010, EXPIRES 4-2-2020.

OWNER OF U.S. REG. NO. 3,155,436.

FOR PHARMACEUTICAL PREPARATIONS, NAMELY, ANTI-INFECTIVES FOR USE IN OR AS CHEMOTHERAPEUTICS; PHARMACEUTICAL PREPARATIONS FOR THE TREATMENT OF VIRAL DISEASES FOR USE IN OR AS CHEMOTHERAPEUTICS (U.S. CLS. 6, 18, 44, 46, 51 AND 52).

GENE MACIOL, EXAMINING ATTORNEY

THE MARK CONSISTS OF STANDARD CHARACTERS WITHOUT CLAIM TO ANY PARTICULAR FONT, STYLE, SIZE, OR COLOR.

PRIORITY CLAIMED UNDER SEC. 44(D) ON CANADA APPLICATION NO. 1452039, FILED 9-16-2009, REG. NO. TMA786912, DATED 1-11-2011, EXPIRES 1-11-2026.

FOR INSECTICIDES FOR HOME, GARDEN AND LAWN USE AND FOR PROFESSIONAL USE; INSECTICIDE FOR AGRICULTURAL USE; INSECTICIDES; INSECTICIDES FOR AGRICULTURAL USE; INSECTICIDES FOR DOMESTIC USE (U.S. CLS. 6, 18, 44, 46, 51 AND 52).

KIM MONINGHOFF, EXAMINING ATTORNEY

SN 77-815,119. BLISTEX INC., OAK BROOK, IL. FILED 8-28-2009.

SN 77-837,269. NATURAL IMMUNOGENICS CORPORATION, POMPANO BEACH, FL. FILED 9-29-2009.

**BLISTEX DAY & NIGHT**

**The Leader In Hydrosol  
Technology**

THE MARK CONSISTS OF STANDARD CHARACTERS WITHOUT CLAIM TO ANY PARTICULAR FONT, STYLE, SIZE, OR COLOR.

OWNER OF U.S. REG. NOS. 804,558, 1,373,396 AND OTHERS.

NO CLAIM IS MADE TO THE EXCLUSIVE RIGHT TO USE "DAY & NIGHT", APART FROM THE MARK AS SHOWN.

FOR MEDICATED LIP CARE PREPARATIONS, MEDICATED TOPICAL CREAMS, LOTIONS, GELS, BALMS, AND OINTMENTS FOR HUMAN USE FOR LIP AND SKIN DRYNESS, COLD SORES, AND FOR LIP AND SKIN CARE (U.S. CLS. 6, 18, 44, 46, 51 AND 52).

LINDSEY RUBIN, EXAMINING ATTORNEY

THE MARK CONSISTS OF STANDARD CHARACTERS WITHOUT CLAIM TO ANY PARTICULAR FONT, STYLE, SIZE, OR COLOR.

NO CLAIM IS MADE TO THE EXCLUSIVE RIGHT TO USE "HYDROSOL TECHNOLOGY", APART FROM THE MARK AS SHOWN.

FOR DIETARY AND NUTRITIONAL SUPPLEMENTS CONTAINING HYDROSOL; MINERAL SUPPLEMENTS CONTAINING HYDROSOL (U.S. CLS. 6, 18, 44, 46, 51 AND 52).

FIRST USE 9-1-2009; IN COMMERCE 9-1-2009.

DOMINICK J. SALEMI, EXAMINING ATTORNEY

**CLASS 5—(Continued).**

SN 77-847,989. COSWAY (M) SDN. BHD., 50200 KUALA LUMPUR, MALAYSIA, FILED 10-13-2009.



OWNER OF MALAYSIA REG. NO. 06022672, DATED 12-11-2006, EXPIRES 12-11-2016.

THE MARK CONSISTS OF THE STYLIZED LETTERS "SC" AND A STYLIZED DRAWING OF TWO LEAVES ABOVE THE LETTERS.

FOR HERBAL SANITARY NAPKINS (U.S. CLS. 6, 18, 44, 46, 51 AND 52).

AMEEN IMAM, EXAMINING ATTORNEY

SN 77-854,333. KISEIDO U.S.A. INC., LOS ANGELES, CA. FILED 10-21-2009.

海藻の奇蹟

NO CLAIM IS MADE TO THE EXCLUSIVE RIGHT TO USE THE NON-LATIN CHARACTERS THAT TRANSLITERATE TO SPECIFY LATIN CHARACTER TRANSLITERATION OF THE TERM SEAWEED, APART FROM THE MARK AS SHOWN.

THE MARK CONSISTS OF 5 JAPANESE CHARACTERS ARRANGED VERTICALLY THAT TRANSLITERATE TO "KAISOU NO KISEKI".

THE NON-LATIN CHARACTERS IN THE MARK TRANSLITERATE TO "KAISOU NO KISEKI" AND THIS MEANS "THE MIRACLE OF SEAWEED" IN ENGLISH.

FOR DIETARY AND NUTRITIONAL SUPPLEMENTS CONTAINING SEAWEED (U.S. CLS. 6, 18, 44, 46, 51 AND 52).

FIRST USE 10-20-2009; IN COMMERCE 10-20-2009.  
JAY FLOWERS, EXAMINING ATTORNEY

**CLASS 5—(Continued).**

SN 77-859,045. BIOFOREST TECHNOLOGIES INC., SAULT STE.MARIE, ON, CANADA, FILED 10-28-2009.

TREEAZIN

THE MARK CONSISTS OF STANDARD CHARACTERS WITHOUT CLAIM TO ANY PARTICULAR FONT, STYLE, SIZE, OR COLOR.

OWNER OF CANADA REG. NO. TMA742084, DATED 6-17-2009, EXPIRES 6-17-2024.

FOR (BASED ON INTENT TO USE) PESTICIDES (BASED ON 44(E)) PESTICIDES (U.S. CLS. 6, 18, 44, 46, 51 AND 52).

CHRISTINA SOBRAL, EXAMINING ATTORNEY

SN 77-905,960. VERSAFLEX, INC., KANSAS CITY, KS. FILED 1-6-2010.

CROBEFLEX

THE MARK CONSISTS OF STANDARD CHARACTERS WITHOUT CLAIM TO ANY PARTICULAR FONT, STYLE, SIZE, OR COLOR.

FOR ANTIMICROBIAL COATINGS FOR EXTERIOR AND INTERIOR USE TO TREAT THE GROWTH OF MOLD, MILDEW, BACTERIA AND FUNGUS ON VARIOUS SURFACES; ANTIMICROBIAL POLYMER COATINGS FOR APPLICATION TO VARIOUS SURFACES, NAMELY, CONCRETE, METAL AND WOOD; ANTIMICROBIAL POLYMER COATINGS FOR APPLICATION TO BUILDING STRUCTURES (U.S. CLS. 6, 18, 44, 46, 51 AND 52).

TRACY CROSS, EXAMINING ATTORNEY

SN 77-965,051. MURAD, INC., EL SEGUNDO, CA. FILED 3-22-2010.

THE DOCTOR BRAND

THE MARK CONSISTS OF STANDARD CHARACTERS WITHOUT CLAIM TO ANY PARTICULAR FONT, STYLE, SIZE, OR COLOR.

OWNER OF U.S. REG. NO. 3,013,575.

NO CLAIM IS MADE TO THE EXCLUSIVE RIGHT TO USE "BRAND", APART FROM THE MARK AS SHOWN.

FOR DIETARY AND NUTRITIONAL SUPPLEMENTS; VITAMINS (U.S. CLS. 6, 18, 44, 46, 51 AND 52).

NICHOLAS ALTREE, EXAMINING ATTORNEY

**CLASS 5—(Continued).**

SN 79-087,630. GALENICA AB, SWEDEN, FILED 6-18-2010.

**OVISON**

THE MARK CONSISTS OF STANDARD CHARACTERS WITHOUT CLAIM TO ANY PARTICULAR FONT, STYLE, SIZE, OR COLOR.

PRIORITY DATE OF 12-21-2009 IS CLAIMED.

OWNER OF INTERNATIONAL REGISTRATION 1051901 DATED 6-18-2010, EXPIRES 6-18-2020.

THE WORDING "OVISON" HAS NO MEANING IN A FOREIGN LANGUAGE.

FOR PHARMACEUTICAL AND VETERINARY PREPARATIONS FOR THE PREVENTION AND TREATMENT OF DISORDERS OF THE NERVOUS SYSTEM, THE IMMUNE SYSTEM, THE CARDIO-VASCULAR SYSTEM, THE METABOLIC SYSTEM, THE RESPIRATORY SYSTEM, THE MUSCULO-SKELETAL SYSTEM, THE GENITOURINARY SYSTEM; PHARMACEUTICAL AND VETERINARY PREPARATIONS FOR THE TREATMENT OF INFLAMMATORY DISORDERS; PHARMACEUTICAL AND VETERINARY PREPARATIONS FOR USE IN DERMATOLOGY, ONCOLOGY, HEMATOLOGY AND IN TISSUE AND ORGAN TRANSPLANTATION, IN OPHTHALMOLOGY AND FOR GASTROENTEROLOGICAL DISORDERS; SANITARY PREPARATIONS FOR MEDICAL PURPOSES; DIETETIC FOODS ADAPTED FOR MEDICAL USE; FOOD FOR BABIES; MEDICAL PLASTERS; MEDICAL DRESSINGS; MATERIAL FOR STOPPING TEETH, DENTAL WAX; ALL PURPOSE DISINFECTANTS; PREPARATIONS FOR DESTROYING VERMIN; FUNGICIDES, HERBICIDES (U.S. CLS. 6, 18, 44, 46, 51 AND 52).

ELI HELLMAN, EXAMINING ATTORNEY

**CLASS 5—(Continued).**

SN 79-092,340. NOVARTIS AG, SWITZERLAND, FILED 12-31-2010.

**AUREXSERO**

THE MARK CONSISTS OF STANDARD CHARACTERS WITHOUT CLAIM TO ANY PARTICULAR FONT, STYLE, SIZE, OR COLOR.

PRIORITY DATE OF 11-23-2010 IS CLAIMED.

OWNER OF INTERNATIONAL REGISTRATION 1064450 DATED 12-31-2010, EXPIRES 12-31-2020.

FOR VACCINES FOR HUMAN USE (U.S. CLS. 6, 18, 44, 46, 51 AND 52).

JOHN HWANG, EXAMINING ATTORNEY

SN 79-092,341. NOVARTIS AG, SWITZERLAND, FILED 12-31-2010.

**STAXSERO**

THE MARK CONSISTS OF STANDARD CHARACTERS WITHOUT CLAIM TO ANY PARTICULAR FONT, STYLE, SIZE, OR COLOR.

PRIORITY DATE OF 11-23-2010 IS CLAIMED.

OWNER OF INTERNATIONAL REGISTRATION 1064451 DATED 12-31-2010, EXPIRES 12-31-2020.

FOR VACCINES FOR HUMAN USE (U.S. CLS. 6, 18, 44, 46, 51 AND 52).

JOHN HWANG, EXAMINING ATTORNEY

SN 79-092,338. NOVARTIS AG, SWITZERLAND, FILED 12-31-2010.

**ALLXSERO**

THE MARK CONSISTS OF STANDARD CHARACTERS WITHOUT CLAIM TO ANY PARTICULAR FONT, STYLE, SIZE, OR COLOR.

PRIORITY DATE OF 11-23-2010 IS CLAIMED.

OWNER OF INTERNATIONAL REGISTRATION 1064448 DATED 12-31-2010, EXPIRES 12-31-2020.

FOR VACCINES FOR HUMAN USE (U.S. CLS. 6, 18, 44, 46, 51 AND 52).

JOHN HWANG, EXAMINING ATTORNEY

SN 79-092,342. NOVARTIS AG, SWITZERLAND, FILED 12-31-2010.

**FLUXSERO**

THE MARK CONSISTS OF STANDARD CHARACTERS WITHOUT CLAIM TO ANY PARTICULAR FONT, STYLE, SIZE, OR COLOR.

PRIORITY DATE OF 11-23-2010 IS CLAIMED.

OWNER OF INTERNATIONAL REGISTRATION 1064452 DATED 12-31-2010, EXPIRES 12-31-2020.

FOR VACCINES FOR HUMAN USE (U.S. CLS. 6, 18, 44, 46, 51 AND 52).

JOHN HWANG, EXAMINING ATTORNEY

SN 79-092,339. NOVARTIS AG, SWITZERLAND, FILED 12-31-2010.

**MENXSERO**

THE MARK CONSISTS OF STANDARD CHARACTERS WITHOUT CLAIM TO ANY PARTICULAR FONT, STYLE, SIZE, OR COLOR.

PRIORITY DATE OF 11-23-2010 IS CLAIMED.

OWNER OF INTERNATIONAL REGISTRATION 1064449 DATED 12-31-2010, EXPIRES 12-31-2020.

FOR VACCINES FOR HUMAN USE (U.S. CLS. 6, 18, 44, 46, 51 AND 52).

JOHN HWANG, EXAMINING ATTORNEY

SN 79-092,385. NOVARTIS AG, SWITZERLAND, FILED 11-25-2010.

**INFLUPAN**

THE MARK CONSISTS OF STANDARD CHARACTERS WITHOUT CLAIM TO ANY PARTICULAR FONT, STYLE, SIZE, OR COLOR.

PRIORITY DATE OF 8-3-2010 IS CLAIMED.

OWNER OF INTERNATIONAL REGISTRATION 1064572 DATED 11-25-2010, EXPIRES 11-25-2020.

FOR VACCINES FOR HUMAN USE (U.S. CLS. 6, 18, 44, 46, 51 AND 52).

JOHN HWANG, EXAMINING ATTORNEY

**CLASS 5—(Continued).**

SN 79-092,386. NOVARTIS AG, SWITZERLAND, FILED 11-25-2010.

# IMMUPAN

THE MARK CONSISTS OF STANDARD CHARACTERS WITHOUT CLAIM TO ANY PARTICULAR FONT, STYLE, SIZE, OR COLOR.

PRIORITY DATE OF 8-3-2010 IS CLAIMED.  
OWNER OF INTERNATIONAL REGISTRATION 1064573 DATED 11-25-2010, EXPIRES 11-25-2020.  
FOR VACCINES FOR HUMAN USE (U.S. CLS. 6, 18, 44, 46, 51 AND 52).  
JOHN HWANG, EXAMINING ATTORNEY

---

SN 79-092,387. NOVARTIS AG, SWITZERLAND, FILED 11-25-2010.

# INFLUAD

THE MARK CONSISTS OF STANDARD CHARACTERS WITHOUT CLAIM TO ANY PARTICULAR FONT, STYLE, SIZE, OR COLOR.

PRIORITY DATE OF 9-30-2010 IS CLAIMED.  
OWNER OF INTERNATIONAL REGISTRATION 1064574 DATED 11-25-2010, EXPIRES 11-25-2020.  
FOR VACCINES FOR HUMAN USE (U.S. CLS. 6, 18, 44, 46, 51 AND 52).  
JOHN HWANG, EXAMINING ATTORNEY

---

SN 85-002,366. FUSION PHARMACEUTICALS, CAMARILLO, CA. FILED 3-30-2010.

# TABRADOL

THE MARK CONSISTS OF STANDARD CHARACTERS WITHOUT CLAIM TO ANY PARTICULAR FONT, STYLE, SIZE, OR COLOR.

SEC. 2(F).  
FOR ANALGESIC AND MUSCLE RELAXANT PHARMACEUTICAL PREPARATIONS; DRUG DELIVERY AGENTS CONSISTING OF COMPOUNDS THAT FACILITATE DELIVERY OF A WIDE RANGE OF PHARMACEUTICALS; DRUG DELIVERY AGENTS IN THE FORM OF POWDERS THAT PROVIDE CONTROLLED RELEASE OF THE ACTIVE INGREDIENTS FOR A WIDE VARIETY OF PHARMACEUTICALS (U.S. CLS. 6, 18, 44, 46, 51 AND 52).  
FIRST USE 10-0-2009; IN COMMERCE 10-0-2009.  
WILLIAM P. SHANAHAN, EXAMINING ATTORNEY

**CLASS 5—(Continued).**

SN 85-002,390. FUSION PHARMACEUTICALS, CAMARILLO, CA. FILED 3-30-2010.

# SYNAPRYN

THE MARK CONSISTS OF STANDARD CHARACTERS WITHOUT CLAIM TO ANY PARTICULAR FONT, STYLE, SIZE, OR COLOR.

SEC. 2(F).  
FOR ANALGESIC AND MUSCLE RELAXANT PHARMACEUTICAL PREPARATIONS; DRUG DELIVERY AGENTS CONSISTING OF COMPOUNDS THAT FACILITATE DELIVERY OF A WIDE RANGE OF PHARMACEUTICALS; DRUG DELIVERY AGENTS IN THE FORM OF POWDERS THAT PROVIDE CONTROLLED RELEASE OF THE ACTIVE INGREDIENTS FOR A WIDE VARIETY OF PHARMACEUTICALS (U.S. CLS. 6, 18, 44, 46, 51 AND 52).  
FIRST USE 10-0-2009; IN COMMERCE 10-0-2009.  
WILLIAM P. SHANAHAN, EXAMINING ATTORNEY

---

SN 85-008,360. JONES SODA CO. (USA) INC., SEATTLE, WA. FILED 4-7-2010.

# SMARTASS

THE MARK CONSISTS OF STANDARD CHARACTERS WITHOUT CLAIM TO ANY PARTICULAR FONT, STYLE, SIZE, OR COLOR.

FOR NUTRITIONAL BEVERAGES, NAMELY, BEVERAGES FORTIFIED WITH SUPPLEMENTS (U.S. CLS. 6, 18, 44, 46, 51 AND 52).  
INGA ERVIN, EXAMINING ATTORNEY

---

SN 85-011,394. SCHERING-PLOUGH HEALTHCARE PRODUCTS, INC., MEMPHIS, TN. FILED 4-12-2010.

# SWEATACT

THE MARK CONSISTS OF STANDARD CHARACTERS WITHOUT CLAIM TO ANY PARTICULAR FONT, STYLE, SIZE, OR COLOR.

FOR MEDICATED FOOT POWDERS AND SPRAYS (U.S. CLS. 6, 18, 44, 46, 51 AND 52).  
MEGHAN REINHART, EXAMINING ATTORNEY

**CLASS 5—(Continued).**

SN 85-020,225. ENRIQUE SALINAS PEREZ, SANTA CATARINA, N.L., MEXICO, FILED 4-22-2010.

# BELACAPS

THE MARK CONSISTS OF STANDARD CHARACTERS WITHOUT CLAIM TO ANY PARTICULAR FONT, STYLE, SIZE, OR COLOR.

FOR MINERAL NUTRITIONAL SUPPLEMENTS; PHARMACEUTICAL PREPARATIONS, NAMELY, APPE- TITE SUPPRESSANTS, PHARMACEUTICAL PREPARA- TIONS FOR THE TREATMENT OF INFECTIOUS DISEASES, PHARMACEUTICAL PREPARATIONS FOR WOUNDS, PHARMACEUTICAL PREPARATIONS FOR USE IN DERMATOLOGY; SANITARY PREPARATIONS FOR MEDICAL USE; DIETETIC SUBSTANCES FOR MEDICAL USE, NAMELY, DIETETIC BEVERAGES ADAPTED FOR MEDICAL PURPOSES; DIETETIC FOODS ADAPTED FOR MEDICAL USE; BABY FOOD; HERB TEA FOR MEDICAL PURPOSES; HERBALIST MEDICAMENTS, NAMELY, FOR TREATING SKIN DIS- ORDERS; MEDICINAL HERB COMPOUNDS FOR INFU- SION; MEDICINAL HERB INFUSION; ENCAPSULATED MEDICINAL HERBS; MEDICINAL HERBS EXTRACTS; MEDICINAL HERB LIQUID EXTRACT IN GELATI- NOUS CAPSULE FORM, NAMELY, PEARLS (U.S. CLS. 6, 18, 44, 46, 51 AND 52).

FIRST USE 6-17-2009; IN COMMERCE 1-28-2010.  
KATHERINE M. DUBRAY, EXAMINING ATTORNEY

**CLASS 5—(Continued).**

SN 85-020,338. ENRIQUE SALINAS PEREZ, SANTA CATARINA, N.L., MEXICO, FILED 4-22-2010.

# HIC

THE MARK CONSISTS OF STANDARD CHARACTERS WITHOUT CLAIM TO ANY PARTICULAR FONT, STYLE, SIZE, OR COLOR.

FOR MINERAL NUTRITIONAL SUPPLEMENTS; PHARMACEUTICAL PREPARATIONS, NAMELY, APPE- TITE SUPPRESSANTS, PHARMACEUTICAL PREPARA- TIONS FOR THE TREATMENT OF INFECTIOUS DISEASES, PHARMACEUTICAL PREPARATIONS FOR WOUNDS, PHARMACEUTICAL PREPARATIONS FOR USE IN DERMATOLOGY; SANITARY PREPARATIONS FOR MEDICAL USE; DIETETIC SUBSTANCES FOR MEDICAL USE, NAMELY, DIETETIC BEVERAGES ADAPTED FOR MEDICAL PURPOSES; DIETETIC FOODS ADAPTED FOR MEDICAL USE; BABY FOOD; HERB TEA FOR MEDICAL PURPOSES; HERBALIST MEDICAMENTS, NAMELY, FOR TREATING SKIN DIS- ORDERS; MEDICINAL HERB COMPOUNDS FOR INFU- SION; MEDICINAL HERB INFUSION; ENCAPSULATED MEDICINAL HERBS; MEDICINAL HERBS EXTRACTS; MEDICINAL HERB LIQUID EXTRACT IN GELATI- NOUS CAPSULE FORM, NAMELY, PEARLS (U.S. CLS. 6, 18, 44, 46, 51 AND 52).

FIRST USE 9-24-2007; IN COMMERCE 1-28-2010.  
KATHERINE M. DUBRAY, EXAMINING ATTORNEY

---

SN 85-020,287. ENRIQUE SALINAS PEREZ, SANTA CATARINA, N.L., MEXICO, FILED 4-22-2010.

# MV-FLEX

THE MARK CONSISTS OF STANDARD CHARACTERS WITHOUT CLAIM TO ANY PARTICULAR FONT, STYLE, SIZE, OR COLOR.

FOR MINERAL NUTRITIONAL SUPPLEMENTS; PHARMACEUTICAL PREPARATIONS, NAMELY, APPE- TITE SUPPRESSANTS, PHARMACEUTICAL PREPARA- TIONS FOR THE TREATMENT OF INFECTIOUS DISEASES, PHARMACEUTICAL PREPARATIONS FOR WOUNDS, PHARMACEUTICAL PREPARATIONS FOR USE IN DERMATOLOGY; SANITARY PREPARATIONS FOR MEDICAL USE; DIETETIC SUBSTANCES FOR MEDICAL USE, NAMELY, DIETETIC BEVERAGES ADAPTED FOR MEDICAL PURPOSES; DIETETIC FOODS ADAPTED FOR MEDICAL USE; BABY FOOD; HERB TEA FOR MEDICAL PURPOSES; HERBALIST MEDICAMENTS, NAMELY, FOR TREATING SKIN DIS- ORDERS; MEDICINAL HERB COMPOUNDS FOR INFU- SION; MEDICINAL HERB INFUSION; ENCAPSULATED MEDICINAL HERBS; MEDICINAL HERBS EXTRACTS; MEDICINAL HERB LIQUID EXTRACT IN GELATI- NOUS CAPSULE FORM, NAMELY, PEARLS (U.S. CLS. 6, 18, 44, 46, 51 AND 52).

FIRST USE 5-7-2007; IN COMMERCE 1-28-2010.  
KATHERINE M. DUBRAY, EXAMINING ATTORNEY

---

SN 85-020,353. ENRIQUE SALINAS PEREZ, SANTA CATARINA, N.L., MEXICO, FILED 4-22-2010.

# DIABEPACK

THE MARK CONSISTS OF STANDARD CHARACTERS WITHOUT CLAIM TO ANY PARTICULAR FONT, STYLE, SIZE, OR COLOR.

FOR MINERAL NUTRITIONAL SUPPLEMENTS; PHARMACEUTICAL PREPARATIONS, NAMELY, APPE- TITE SUPPRESSANTS, PHARMACEUTICAL PREPARA- TIONS FOR THE TREATMENT OF INFECTIOUS DISEASES, PHARMACEUTICAL PREPARATIONS FOR WOUNDS, PHARMACEUTICAL PREPARATIONS FOR USE IN DERMATOLOGY; SANITARY PREPARATIONS FOR MEDICAL USE; DIETETIC SUBSTANCES FOR MEDICAL USE, NAMELY, DIETETIC BEVERAGES ADAPTED FOR MEDICAL PURPOSES; DIETETIC FOODS ADAPTED FOR MEDICAL USE; BABY FOOD; HERB TEA FOR MEDICAL PURPOSES; HERBALIST MEDICAMENTS, NAMELY, FOR TREATING SKIN DIS- ORDERS; MEDICINAL HERB COMPOUNDS FOR INFU- SION; MEDICINAL HERB INFUSION; ENCAPSULATED MEDICINAL HERBS; MEDICINAL HERBS EXTRACTS; MEDICINAL HERB LIQUID EXTRACT IN GELATI- NOUS CAPSULE FORM, NAMELY, PEARLS (U.S. CLS. 6, 18, 44, 46, 51 AND 52).

FIRST USE 9-14-2006; IN COMMERCE 1-28-2010.  
KATHERINE M. DUBRAY, EXAMINING ATTORNEY

**CLASS 5—(Continued).**

SN 85-020,368. ENRIQUE SALINAS PEREZ, SANTA CATARINA, N.L., MEXICO, FILED 4-22-2010.

**BALANFEM**

THE MARK CONSISTS OF STANDARD CHARACTERS WITHOUT CLAIM TO ANY PARTICULAR FONT, STYLE, SIZE, OR COLOR.

FOR MINERAL NUTRITIONAL SUPPLEMENTS; PHARMACEUTICAL PREPARATIONS, NAMELY, APETITE SUPPRESSANTS, PHARMACEUTICAL PREPARATIONS FOR THE TREATMENT OF INFECTIOUS DISEASES, PHARMACEUTICAL PREPARATIONS FOR WOUNDS, PHARMACEUTICAL PREPARATIONS FOR USE IN DERMATOLOGY; SANITARY PREPARATIONS FOR MEDICAL USE; DIETETIC SUBSTANCES FOR MEDICAL USE, NAMELY, DIETETIC BEVERAGES ADAPTED FOR MEDICAL PURPOSES, DIETETIC FOODS ADAPTED FOR MEDICAL USE; BABY FOOD; HERB TEA FOR MEDICAL PURPOSES; HERBALIST MEDICAMENTS, NAMELY, FOR TREATING SKIN DISORDERS; MEDICINAL HERB COMPOUNDS FOR INFUSION; MEDICINAL HERB INFUSION; ENCAPSULATED MEDICINAL HERBS; MEDICINAL HERBS EXTRACTS; MEDICINAL HERB LIQUID EXTRACT IN GELATINOUS CAPSULE FORM, NAMELY, PEARLS (U.S. CLS. 6, 18, 44, 46, 51 AND 52).

FIRST USE 8-31-2006; IN COMMERCE 1-28-2010.  
KATHERINE M. DUBRAY, EXAMINING ATTORNEY

SN 85-021,992. AQTIS I.P. B.V., UTRECHT, NETHERLANDS, FILED 4-23-2010.

**AQTIS**

THE MARK CONSISTS OF STANDARD CHARACTERS WITHOUT CLAIM TO ANY PARTICULAR FONT, STYLE, SIZE, OR COLOR.

PRIORITY CLAIMED UNDER SEC. 44(D) ON BENELUX APPLICATION NO. 1198213, FILED 2-26-2010, REG. NO. 0879383, DATED 4-8-2010, EXPIRES 2-26-2020.

FOR MEDICAL DERMATOLOGICAL PREPARATIONS, NAMELY, INJECTABLE DERMAL FILLER IN THE FORM OF PRE-FILLED SYRINGES FOR USE IN FILLING OUT WRINKLES, FOLDS, SCARS, LIPS, FOR FACE AND BODY CONTOURING AND FOR REJUVENATING THE SKIN; MEDICAL TREATMENT PREPARATIONS FOR COSMETIC RESTORATION AND AUGMENTATION, NAMELY, INJECTABLE DERMAL FILLER IN THE FORM OF PRE-FILLED SYRINGES FOR USE AS A TREATMENT ALTERNATIVE TO PLASTIC SURGERY AND INTERNAL TISSUE AUGMENTATION (U.S. CLS. 6, 18, 44, 46, 51 AND 52).

STEVEN PEREZ, EXAMINING ATTORNEY

**CLASS 5—(Continued).**

SN 85-022,028. FLEMING AND COMPANY, PHARMACEUTICALS, FENTON, MO. FILED 4-23-2010.

**OBEGYN**

THE MARK CONSISTS OF STANDARD CHARACTERS WITHOUT CLAIM TO ANY PARTICULAR FONT, STYLE, SIZE, OR COLOR.

FOR PRENATAL VITAMINS (U.S. CLS. 6, 18, 44, 46, 51 AND 52).

INGRID C. EULIN, EXAMINING ATTORNEY

SN 85-027,403. LINKS MEDICAL PRODUCTS INC., IRVINE, CA. FILED 4-30-2010.

**MANUKAPLI**

THE MARK CONSISTS OF STANDARD CHARACTERS WITHOUT CLAIM TO ANY PARTICULAR FONT, STYLE, SIZE, OR COLOR.

FOR GEL WOUND DRESSINGS IMPREGNATED WITH MEDICAL GRADE HONEY OF THE MANUKA VARIETY (U.S. CLS. 6, 18, 44, 46, 51 AND 52).

FIRST USE 3-1-2010; IN COMMERCE 3-1-2010.  
HENRY S. ZAK, EXAMINING ATTORNEY

SN 85-027,425. LINKS MEDICAL PRODUCTS INC., IRVINE, CA. FILED 4-30-2010.

**MANUKAHD BORDER**

THE MARK CONSISTS OF STANDARD CHARACTERS WITHOUT CLAIM TO ANY PARTICULAR FONT, STYLE, SIZE, OR COLOR.

FOR SUPER ABSORBENT ADHERENT BURN DRESSINGS, WOUND DRESSINGS AND MEDICAL DRESSINGS IMPREGNATED WITH MEDICAL GRADE HONEY OF THE MANUKA VARIETY (U.S. CLS. 6, 18, 44, 46, 51 AND 52).

HENRY S. ZAK, EXAMINING ATTORNEY

**CLASS 5—(Continued).**

SN 85-036,577. BIOCON LIMITED, BANGALORE, KARNATAKA, INDIA, FILED 5-12-2010.

# IMLOG

THE MARK CONSISTS OF STANDARD CHARACTERS WITHOUT CLAIM TO ANY PARTICULAR FONT, STYLE, SIZE, OR COLOR.

OWNER OF NEW ZEALAND REG. NO. 823622, DATED 11-4-2010, EXPIRES 5-4-2020.

FOR PHARMACEUTICAL PREPARATIONS FOR TREATING DIABETES (U.S. CLS. 6, 18, 44, 46, 51 AND 52).

SAIMA MAKHDOOM, EXAMINING ATTORNEY

---

SN 85-036,685. BIOCON LIMITED, BANGALORE, KARNATAKA, INDIA, FILED 5-12-2010.

# BASALOG

THE MARK CONSISTS OF STANDARD CHARACTERS WITHOUT CLAIM TO ANY PARTICULAR FONT, STYLE, SIZE, OR COLOR.

OWNER OF NEW ZEALAND REG. NO. 823623, DATED 11-4-2010, EXPIRES 5-4-2020.

FOR PHARMACEUTICAL PREPARATIONS FOR TREATING DIABETES (U.S. CLS. 6, 18, 44, 46, 51 AND 52).

SAIMA MAKHDOOM, EXAMINING ATTORNEY

---

SN 85-041,930. NEXUS DX, INC., SAN DIEGO, CA. FILED 5-18-2010.

# DECISION POINT

THE MARK CONSISTS OF STANDARD CHARACTERS WITHOUT CLAIM TO ANY PARTICULAR FONT, STYLE, SIZE, OR COLOR.

FOR MEDICAL TEST KITS, CONSISTING PRIMARILY OF MEDICAL DIAGNOSTIC REAGENTS AND SYSTEMS PRIMARILY COMPOSED OF PROTEINS, PROTEIN MARKER, PROTEIN SEPARATOR AND A PROTEIN-MARKER READER USED IN THE DIAGNOSIS OF CARDIAC DISEASES (U.S. CLS. 6, 18, 44, 46, 51 AND 52).

FIRST USE 10-17-2003; IN COMMERCE 10-17-2003.

KATHERINE CONNOLLY, EXAMINING ATTORNEY

**CLASS 5—(Continued).**

SN 85-081,668. OBSHESTVO S OGRANICHENNOY OTVETSTVENNOSTYU "INGAPHARM", MOSCOW, RUSSIAN FED., FILED 7-9-2010.

# Ingavirin

THE MARK CONSISTS OF STANDARD CHARACTERS WITHOUT CLAIM TO ANY PARTICULAR FONT, STYLE, SIZE, OR COLOR.

THE WORDING "INGAVIRIN" HAS NO MEANING IN A FOREIGN LANGUAGE.

FOR PHARMACEUTICAL PREPARATIONS HAVING ANTIVIRAL, ANTI-INFLAMMATORY AND IMMUNOMODULATORY ACTION FOR PEOPLE FOR THE TREATMENT OF VIRUS INFECTIONS INCLUDING FLU OF DIFFERENT ETIOLOGY, PARAINFLUENZA, ACUTE RESPIRATORY VIRUS INFECTIONS, ADENOVIRUS INFECTIONS; VETERINARY PHARMACEUTICAL PREPARATIONS HAVING ANTIVIRAL, ANTI-INFLAMMATORY AND IMMUNOMODULATORY ACTION FOR THE TREATMENT OF VIRUS INFECTIONS IN DOMESTIC ANIMALS (U.S. CLS. 6, 18, 44, 46, 51 AND 52).

JANICE L. MCMORROW, EXAMINING ATTORNEY

---

SN 85-084,419. BIONICHE LIFE SCIENCES INC., BELLEVILLE, ONTARIO, CANADA, FILED 7-14-2010.

# NEXHA

THE MARK CONSISTS OF STANDARD CHARACTERS WITHOUT CLAIM TO ANY PARTICULAR FONT, STYLE, SIZE, OR COLOR.

PRIORITY CLAIMED UNDER SEC. 44(D) ON CANADA APPLICATION NO. 1487101, FILED 6-30-2010.

FOR VETERINARY PREPARATION FOR THE TREATMENT OF JOINT DYSFUNCTION ASSOCIATED WITH EQUINE OSTEOARTHRITIS (U.S. CLS. 6, 18, 44, 46, 51 AND 52).

ALICE BENMAMAN, EXAMINING ATTORNEY

---

SN 85-092,805. MICHAEL ROTHBARD, CARPINTERIA, CA. FILED 7-26-2010.

# WAKE UP HAPPY

THE MARK CONSISTS OF STANDARD CHARACTERS WITHOUT CLAIM TO ANY PARTICULAR FONT, STYLE, SIZE, OR COLOR.

OWNER OF U.S. REG. NO. 3,426,916.

FOR DIETARY SUPPLEMENTS; SUPPLEMENTS IN THE NATURE OF VITAMIN ENRICHED WATER (U.S. CLS. 6, 18, 44, 46, 51 AND 52).

FIRST USE 7-1-2010; IN COMMERCE 7-1-2010.

KRISTIN DAHLING, EXAMINING ATTORNEY

**CLASS 5—(Continued).**

SN 85-093,458. SUN PHARMACEUTICALS INDUSTRIES LTD, TA SUN PHARMACEUTICALS INDUSTRIES LTD, MUMBAI- 400093, INDIA, FILED 7-27-2010.

# LUNELLE

THE MARK CONSISTS OF STANDARD CHARACTERS WITHOUT CLAIM TO ANY PARTICULAR FONT, STYLE, SIZE, OR COLOR.

FOR PHARMACEUTICAL PREPARATIONS, NAMELY, INJECTABLE CONTRACEPTIVES (U.S. CLS. 6, 18, 44, 46, 51 AND 52).

INGA ERVIN, EXAMINING ATTORNEY

SN 85-095,711. MICHAEL ROTHBARD, CARPINTERIA, CA. FILED 7-29-2010.

# SleepJoy

THE MARK CONSISTS OF STANDARD CHARACTERS WITHOUT CLAIM TO ANY PARTICULAR FONT, STYLE, SIZE, OR COLOR.

OWNER OF U.S. REG. NO. 3,394,933.

FOR DIETARY SUPPLEMENTS; SUPPLEMENTS IN THE NATURE OF VITAMIN ENRICHED WATER (U.S. CLS. 6, 18, 44, 46, 51 AND 52).

FIRST USE 7-15-2010; IN COMMERCE 7-15-2010.

KRISTIN DAHLING, EXAMINING ATTORNEY

SN 85-108,505. VITA-TECH INTERNATIONAL, INC., TUSTIN, CA. FILED 8-16-2010.



OWNER OF U.S. REG. NOS. 2,935,552 AND 3,873,749.  
NO CLAIM IS MADE TO THE EXCLUSIVE RIGHT TO USE "INTERNATIONAL, INC.", APART FROM THE MARK AS SHOWN.

THE MARK CONSISTS OF "VITA-TECH" STACKED ON TOP OF "INTERNATIONAL, INC.", ALL IN STYLIZED LETTERING. THE WORDING IS SUPERIMPOSED OVER A STYLIZED "V" WITH A CIRCLE IN ITS CENTER.

FOR NUTRITIONAL SUPPLEMENTS AND FOOD SUPPLEMENTS (U.S. CLS. 6, 18, 44, 46, 51 AND 52).

FIRST USE 5-5-2009; IN COMMERCE 5-5-2009.

KATHLEEN M. VANSTON, EXAMINING ATTORNEY

**CLASS 5—(Continued).**

SN 85-112,084. BOTANICAL LABORATORIES, INC., FERNDALE, WA. FILED 8-20-2010.



NO CLAIM IS MADE TO THE EXCLUSIVE RIGHT TO USE "DIGESTIVE 3-IN-1 HEALTH", "SOLUBLE FIBER", "PREBIOTICS" AND "ALOE VERA", APART FROM THE MARK AS SHOWN.

THE MARK CONSISTS OF THE WORDS "DIGESTIVE 3-IN-1 HEALTH" OVERLAPPING A SWIRL DESIGN WITH THE WORDS "SOLUBLE FIBER PREBIOTICS ALOE VERA" APPEARING IN A CURVED BANNER DESIGN BELOW.

FOR DIETARY SUPPLEMENTS CONTAINING SOLUBLE FIBER, PREBIOTICS AND ALOE VERA (U.S. CLS. 6, 18, 44, 46, 51 AND 52).

CAROLYN CATALDO, EXAMINING ATTORNEY

SN 85-113,058. LOTUS NUTRACEUTICAL INC, EAST MEADOW, NY. FILED 8-22-2010.



THE COLOR(S) BLUE, RED, WHITE IS/ARE CLAIMED AS A FEATURE OF THE MARK.

THE MARK CONSISTS OF THE FOLLOWING: THE WORDING "HI" AND "WHEY" IN BLUE LETTERS WITH THIN WHITE LINES IN THE INTERIOR OF THE LETTERS, AND A RED ARROW REPLACING THE DASH BETWEEN "HI" AND "WHEY".

FOR NUTRITIONAL DRINKS USED FOR MEAL REPLACEMENT CONTAINING WHEY (U.S. CLS. 6, 18, 44, 46, 51 AND 52).

APRIL ROACH, EXAMINING ATTORNEY

SN 85-115,315. ALLEN SALES CORP., FLETCHER, NC. FILED 8-25-2010.

# ESSENTIAL-V6

THE MARK CONSISTS OF STANDARD CHARACTERS WITHOUT CLAIM TO ANY PARTICULAR FONT, STYLE, SIZE, OR COLOR.

FOR DIETARY SUPPLEMENTS, AND MINERAL PREPARATIONS IN THE NATURE OF A VITAMIN SUPPLEMENT (U.S. CLS. 6, 18, 44, 46, 51 AND 52).

FIRST USE 8-23-2010; IN COMMERCE 8-23-2010.

EUGENIA MARTIN, EXAMINING ATTORNEY



**CLASS 5—(Continued).**

SN 85-127,981. SABINSA CORPORATION, EAST WINDSOR, NJ. FILED 9-13-2010.



OWNER OF U.S. REG. NO. 3,435,381.  
NO CLAIM IS MADE TO THE EXCLUSIVE RIGHT TO USE "CITRIN K", APART FROM THE MARK AS SHOWN. THE COLOR(S) TEAL AND YELLOW IS/ARE CLAIMED AS A FEATURE OF THE MARK.

THE MARK CONSISTS OF STYLIZED STICK FIGURE WITH A HEAD APPEARING IN THE COLOR "TEAL" AND THE BODY APPEARING IN THE COLOR "YELLOW" PARTIALLY ENCASING THE TEXT, WHICH IS DISPLAYED AS A STYLIZED UPPER CASE "C" AND LOWER CASE LETTERS "ITRIN" APPEARING IN THE COLOR TEAL, TO THE RIGHT OF WHICH APPEARS THE UPPER CASE LETTER "K" IN THE COLOR "YELLOW" WITH "TEAL" SHADOW HIGHLIGHTS.

FOR DIETARY SUPPLEMENTS CONTAINING POTASSIUM (U.S. CLS. 6, 18, 44, 46, 51 AND 52).  
RONALD AIKENS, EXAMINING ATTORNEY

SN 85-131,546. EDGE MARKETING GROUP, LLC, AVEN-  
TURA, FL. FILED 9-16-2010.



NO CLAIM IS MADE TO THE EXCLUSIVE RIGHT TO USE "NOX", APART FROM THE MARK AS SHOWN.

THE MARK CONSISTS OF THE WORDS "NOX EDGE" APPEARING IN BLACK BUBBLE LETTERS WITH A WHITE OUTLINE. THE WORD "NOX" APPEARS DIRECTLY ABOVE THE WORD "EDGE". THE BLACK BEHIND THE MARK REPRESENTS BACKGROUND AREAS, AND IS NOT PART OF THE MARK.

FOR DIETARY AND NUTRITIONAL SUPPLEMENTS; DIETARY SUPPLEMENTS; NUTRACEUTICALS FOR USE AS A DIETARY SUPPLEMENT; NUTRITIONAL SUPPLEMENTS; VITAMIN AND MINERAL SUPPLEMENTS; VITAMIN SUPPLEMENTS (U.S. CLS. 6, 18, 44, 46, 51 AND 52).

FIRST USE 4-15-2010; IN COMMERCE 7-1-2010.  
GRETTA YAO, EXAMINING ATTORNEY

**CLASS 5—(Continued).**

SN 85-132,100. INVEKRA, S.A. DE C.V., COL. TLACOPAC, MEXICO, FILED 9-17-2010.

## ANDANTOL

THE MARK CONSISTS OF STANDARD CHARACTERS WITHOUT CLAIM TO ANY PARTICULAR FONT, STYLE, SIZE, OR COLOR.

OWNER OF MEXICO REG. NO. 88658, DATED 4-16-1957, EXPIRES 1-19-2012.

FOR MEDICINES AND PHARMACEUTICAL PREPARATIONS FOR THE TREATMENT OF SUNBURNS, HIVES, RASH AND ALLERGY SYMPTOMS (U.S. CLS. 6, 18, 44, 46, 51 AND 52).

TOBY BULLOFF, EXAMINING ATTORNEY

SN 85-133,377. NOVOTECH NUTRACEUTICALS, INC., VEN-  
TURA, CA. FILED 9-20-2010.

## NUTRA-C

THE MARK CONSISTS OF STANDARD CHARACTERS WITHOUT CLAIM TO ANY PARTICULAR FONT, STYLE, SIZE, OR COLOR.

FOR DIETARY SUPPLEMENTS CONTAINING VITAMIN C (U.S. CLS. 6, 18, 44, 46, 51 AND 52).

FIRST USE 11-12-2009; IN COMMERCE 11-12-2009.  
CHRISTINA SOBRAL, EXAMINING ATTORNEY

SN 85-140,690. ARGOTEC, INC., GREENFIELD, MA. FILED  
9-29-2010.

## ArgoMedPLUS

OWNER OF U.S. REG. NO. 3,819,127.

THE MARK CONSISTS OF THE WORDS "ARGO", "MED" AND "PLUS" ALL APPEARING AS ONE WORD. THE "A" IN "ARGO" AND "M" IN "MED" ARE CAPITALIZED. "PLUS" IS FEATURED IN ALL CAPITAL LETTERS.

FOR MEDICAL DRESSINGS MADE OF POLYURETHANE FILM AND PAPER COMPOSITE (U.S. CLS. 6, 18, 44, 46, 51 AND 52).

JOHN DWYER, EXAMINING ATTORNEY

**CLASS 5—(Continued).**

SN 85-144,482. ALCON, INC., CH-6331 HÜNENBERG, SWITZERLAND, FILED 10-4-2010.

**PROCALYX**

THE MARK CONSISTS OF STANDARD CHARACTERS WITHOUT CLAIM TO ANY PARTICULAR FONT, STYLE, SIZE, OR COLOR.

OWNER OF U.S. REG. NO. 2,893,445.  
FOR OPHTHALMIC PREPARATIONS (U.S. CLS. 6, 18, 44, 46, 51 AND 52).  
CYNTHIA SLOAN, EXAMINING ATTORNEY

---

SN 85-145,973. NOVARTIS AG, BASEL, SWITZERLAND, FILED 10-6-2010.



THE MARK CONSISTS OF A SQUARE COMPOSED OF 16 SMALLER SQUARES AND TWO CONCENTRIC DIAMONDS. AN EIGHT POINT STAR APPEARS WITHIN THE SPACE BETWEEN THE TWO CONCENTRIC DIAMONDS IN THE LOWER RIGHT SECTION OF THE DESIGN.

FOR PHARMACEUTICAL PREPARATIONS FOR THE TREATMENT AND PREVENTION OF CANCER (U.S. CLS. 6, 18, 44, 46, 51 AND 52).  
MARLENE BELL, EXAMINING ATTORNEY

---

SN 85-145,975. NOVARTIS AG, BASEL, SWITZERLAND, FILED 10-6-2010.



NO CLAIM IS MADE TO THE EXCLUSIVE RIGHT TO USE "COMPREHENSIVE APPROACH", APART FROM THE MARK AS SHOWN.

THE MARK CONSISTS OF THE WORDING "THE COMPREHENSIVE APPROACH" AND DESIGN. THE DESIGN CONSISTS OF A SQUARE COMPOSED OF 16 SMALLER SQUARES AND TWO CONCENTRIC DIAMONDS. AN EIGHT POINT STAR APPEARS WITHIN THE SPACE BETWEEN THE TWO CONCENTRIC DIAMONDS THAT APPEAR IN THE LOWER RIGHT SECTION OF THE DESIGN. TO THE RIGHT OF THE DESIGN IS THE WORDING "THE COMPREHENSIVE APPROACH".

FOR PHARMACEUTICAL PREPARATIONS FOR THE TREATMENT AND PREVENTION OF CANCER (U.S. CLS. 6, 18, 44, 46, 51 AND 52).

MARLENE BELL, EXAMINING ATTORNEY

**CLASS 5—(Continued).**

SN 85-150,846. CELGENE CORPORATION, SUMMIT, NJ, FILED 10-12-2010.

**SUVMIDI**

THE MARK CONSISTS OF STANDARD CHARACTERS WITHOUT CLAIM TO ANY PARTICULAR FONT, STYLE, SIZE, OR COLOR.

PRIORITY CLAIMED UNDER SEC. 44(D) ON SWITZERLAND APPLICATION NO. 60659/2010, FILED 10-6-2010, REG. NO. 611360, DATED 10-6-2010, EXPIRES 10-6-2020.

FOR PHARMACEUTICAL PREPARATIONS, NAMELY, CYTOKINE INHIBITORY DRUGS; PHARMACEUTICAL PREPARATIONS THAT MODULATE THE IMMUNE SYSTEM; PHARMACEUTICAL PREPARATIONS FOR THE TREATMENT OF CERTAIN CANCERS AND BLOOD DISEASES AND PRINTED DOSAGE INSTRUCTIONAL MANUALS SOLD TOGETHER AS A UNIT (U.S. CLS. 6, 18, 44, 46, 51 AND 52).

WANDA KAY PRICE, EXAMINING ATTORNEY

---

SN 85-150,878. CELGENE CORPORATION, SUMMIT, NJ, FILED 10-12-2010.

**POMALYST**

THE MARK CONSISTS OF STANDARD CHARACTERS WITHOUT CLAIM TO ANY PARTICULAR FONT, STYLE, SIZE, OR COLOR.

PRIORITY CLAIMED UNDER SEC. 44(D) ON SWITZERLAND APPLICATION NO. 60663/2010, FILED 10-6-2010, REG. NO. 606506, DATED 10-6-2010, EXPIRES 10-6-2020.

FOR PHARMACEUTICAL PREPARATIONS, NAMELY, CYTOKINE INHIBITORY DRUGS; PHARMACEUTICAL PREPARATIONS THAT MODULATE THE IMMUNE SYSTEM; PHARMACEUTICAL PREPARATIONS FOR THE TREATMENT OF CERTAIN CANCERS AND BLOOD DISEASES AND PRINTED DOSAGE INSTRUCTIONAL MANUALS SOLD TOGETHER AS A UNIT (U.S. CLS. 6, 18, 44, 46, 51 AND 52).

WANDA KAY PRICE, EXAMINING ATTORNEY

**CLASS 5—(Continued).**

SN 85-151,725. SAS COATINGS LLC, OLD BRIDGE, NJ. FILED 10-13-2010.

## SAS Coatings

THE MARK CONSISTS OF STANDARD CHARACTERS WITHOUT CLAIM TO ANY PARTICULAR FONT, STYLE, SIZE, OR COLOR.

NO CLAIM IS MADE TO THE EXCLUSIVE RIGHT TO USE "COATINGS", APART FROM THE MARK AS SHOWN.

FOR ALL PURPOSE DISINFECTANTS; ALL PURPOSE DISINFECTANTS FOR INHIBITING GROWTH OF BACTERIA, MOLD ETC.; ALL PURPOSE DISINFECTING AND DEODORIZING PREPARATIONS; DISINFECTANT BATHROOM CLEANERS; DISINFECTANT TOILET BOWL CLEANERS; DISINFECTANTS FOR CHEMICAL TOILETS; DISINFECTANTS FOR HYGIENE PURPOSES; DISINFECTANTS FOR HYGIENIC PURPOSES; DISINFECTANTS FOR MEDICAL INSTRUMENTS; DISINFECTANTS FOR SANITARY PURPOSES (U.S. CLS. 6, 18, 44, 46, 51 AND 52).

GISELLE AGOSTO, EXAMINING ATTORNEY

SN 85-153,267. LEWIS, DONALD, ENCINITAS, CA. FILED 10-15-2010.

## FRUIT LOGIC

THE MARK CONSISTS OF STANDARD CHARACTERS WITHOUT CLAIM TO ANY PARTICULAR FONT, STYLE, SIZE, OR COLOR.

NO CLAIM IS MADE TO THE EXCLUSIVE RIGHT TO USE "FRUIT", APART FROM THE MARK AS SHOWN.

FOR DIETARY AND NUTRITIONAL SUPPLEMENTS; DIETARY FOOD SUPPLEMENTS; DIETARY PET SUPPLEMENTS IN THE FORM OF PET TREATS; DIETARY SUPPLEMENTS; DIETARY SUPPLEMENTS FOR PETS; FOOD SUPPLEMENTS; LIQUID VITAMIN SUPPLEMENTS; MINERAL FOOD SUPPLEMENTS; MINERAL NUTRITIONAL SUPPLEMENTS; MINERAL SUPPLEMENTS; MIXED VITAMIN PREPARATIONS; MULTI-VITAMIN PREPARATIONS; NUTRITIONAL SUPPLEMENTS; VITAMIN AND MINERAL SUPPLEMENTS; VITAMINS AND DIETARY FOOD SUPPLEMENTS FOR ANIMALS; VITAMINS FOR PETS (U.S. CLS. 6, 18, 44, 46, 51 AND 52).

CHRISTINE MARTIN, EXAMINING ATTORNEY

**CLASS 5—(Continued).**

SN 85-154,400. ANTLER ATTACK LLC, CLEARWATER, MN. FILED 10-16-2010.

## ANTLER ATTACK

THE MARK CONSISTS OF STANDARD CHARACTERS WITHOUT CLAIM TO ANY PARTICULAR FONT, STYLE, SIZE, OR COLOR.

FOR MINERAL SUPPLEMENTS FOR ANIMALS, NAMELY, FOR DEER (U.S. CLS. 6, 18, 44, 46, 51 AND 52).

FIRST USE 4-7-2010; IN COMMERCE 4-7-2010.

REBECCA EISINGER, EXAMINING ATTORNEY

SN 85-154,611. NITROMED, INC., CHARLOTTE, NC. FILED 10-18-2010.

## BIDIL XR

THE MARK CONSISTS OF STANDARD CHARACTERS WITHOUT CLAIM TO ANY PARTICULAR FONT, STYLE, SIZE, OR COLOR.

OWNER OF U.S. REG. NO. 1,896,747.

NO CLAIM IS MADE TO THE EXCLUSIVE RIGHT TO USE "XR", APART FROM THE MARK AS SHOWN.

FOR PHARMACEUTICALS FOR THE TREATMENT OF HEART FAILURE (U.S. CLS. 6, 18, 44, 46, 51 AND 52).

ELLEN BURNS, EXAMINING ATTORNEY

SN 85-157,185. DEGESCH GMBH, LAUDENBACH, FED REP GERMANY, FILED 10-20-2010.



OWNER OF U.S. REG. NOS. 619,254, 1,275,726 AND OTHERS.

THE MARK CONSISTS OF THE WORDING "DEGESCH PHOSTOXIN" WITH A GLOBE CONTAINING A CROSS DESIGN BETWEEN THE TWO WORDS.

FOR PREPARATIONS FOR DESTROYING INSECTS AND VERMIN (U.S. CLS. 6, 18, 44, 46, 51 AND 52).

FIRST USE 0-0-1958; IN COMMERCE 0-0-1958.

MARC LEIPZIG, EXAMINING ATTORNEY

**CLASS 5—(Continued).**

SN 85-157,303. ICELAND HEALTH, INC., SUNRISE, FL.  
FILED 10-20-2010.

**ICELAND SHIELD**

THE MARK CONSISTS OF STANDARD CHARACTERS  
WITHOUT CLAIM TO ANY PARTICULAR FONT, STYLE,  
SIZE, OR COLOR.

OWNER OF U.S. REG. NO. 2,784,439.  
FOR DIETARY AND NUTRITIONAL SUPPLEMENTS  
(U.S. CLS. 6, 18, 44, 46, 51 AND 52).  
JOHN GARTNER, EXAMINING ATTORNEY

SN 85-157,964. ICELAND HEALTH, INC., SUNRISE, UT.  
FILED 10-21-2010.

**OMEGA ULTIMATE SHIELD**

THE MARK CONSISTS OF STANDARD CHARACTERS  
WITHOUT CLAIM TO ANY PARTICULAR FONT, STYLE,  
SIZE, OR COLOR.

OWNER OF U.S. REG. NO. 2,784,439.  
NO CLAIM IS MADE TO THE EXCLUSIVE RIGHT TO  
USE "OMEGA", APART FROM THE MARK AS SHOWN.  
FOR DIETARY AND NUTRITIONAL SUPPLEMENTS  
CONTAINING OMEGA-3 FATTY ACIDS (U.S. CLS. 6, 18,  
44, 46, 51 AND 52).  
JOHN GARTNER, EXAMINING ATTORNEY

SN 85-157,981. ICELAND HEALTH, INC., SUNRISE, FL.  
FILED 10-21-2010.

**ICELAND HEALTH OMEGA  
ULTIMATE SHIELD**

THE MARK CONSISTS OF STANDARD CHARACTERS  
WITHOUT CLAIM TO ANY PARTICULAR FONT, STYLE,  
SIZE, OR COLOR.

OWNER OF U.S. REG. NO. 2,784,439.  
NO CLAIM IS MADE TO THE EXCLUSIVE RIGHT TO  
USE "HEALTH OMEGA", APART FROM THE MARK AS  
SHOWN.  
FOR DIETARY AND NUTRITIONAL SUPPLEMENTS  
CONTAINING OMEGA-3 FATTY ACIDS (U.S. CLS. 6, 18,  
44, 46, 51 AND 52).  
FIRST USE 10-25-2010; IN COMMERCE 11-8-2010.  
JOHN GARTNER, EXAMINING ATTORNEY

**CLASS 5—(Continued).**

SN 85-158,374. NUTRI-HEALTH SUPPLEMENTS, LLC, COT-  
TONWOOD, AZ. FILED 10-21-2010.

**NUTRI-BEARS**

THE MARK CONSISTS OF STANDARD CHARACTERS  
WITHOUT CLAIM TO ANY PARTICULAR FONT, STYLE,  
SIZE, OR COLOR.

FOR DIETARY SUPPLEMENTS; NUTRITIONAL SUP-  
PLEMENTS (U.S. CLS. 6, 18, 44, 46, 51 AND 52).  
DANNEAN HETZEL, EXAMINING ATTORNEY

SN 85-158,554. BEFIT ENTERPRISES, MORRO BAY, CA.  
FILED 10-21-2010.

**VITA-LANNE**

THE MARK CONSISTS OF STANDARD CHARACTERS  
WITHOUT CLAIM TO ANY PARTICULAR FONT, STYLE,  
SIZE, OR COLOR.

FOR VITAMINS (U.S. CLS. 6, 18, 44, 46, 51 AND 52).  
DOMINIC FATHY, EXAMINING ATTORNEY

SN 85-158,811. ATRIUM MEDICAL CORPORATION, HUD-  
SON, NH. FILED 10-22-2010.

**ABCOAT**

THE MARK CONSISTS OF STANDARD CHARACTERS  
WITHOUT CLAIM TO ANY PARTICULAR FONT, STYLE,  
SIZE, OR COLOR.

FOR PHARMACEUTICAL PREPARATIONS,  
NAMELY, MEDICATED EMULSIONS CONTAINING  
LIPID BASED COMPOSITIONS HAVING ANTI-DESSICA-  
TION AND TISSUE LUBRICATING PROPERTIES  
FOR TREATING SURGICAL AND TRAUMATIC SOFT  
TISSUE WOUNDS; PHARMACEUTICAL PREPARA-  
TIONS, NAMELY, MEDICATED EMULSIONS CON-  
TAINING LIPID BASED COMPOSITIONS HAVING  
ANTI-DESSICATION AND TISSUE LUBRICATING  
PROPERTIES FOR TREATING SURGICAL AND TRAU-  
MATIC SOFT TISSUE WOUNDS WITH ADDITIONAL  
THERAPEUTIC AGENTS (U.S. CLS. 6, 18, 44, 46, 51 AND  
52).

JAY BESCH, EXAMINING ATTORNEY

**CLASS 5—(Continued).**

SN 85-158,959. BIO-PRO MEDICAL LTD., CEASARIA IND. PART, ISRAEL, FILED 10-22-2010.

# Danometrin

THE MARK CONSISTS OF STANDARD CHARACTERS WITHOUT CLAIM TO ANY PARTICULAR FONT, STYLE, SIZE, OR COLOR.

FOR VAGINAL PREPARATIONS, NAMELY, FOR THE TREATMENT OF ENDOMETRIOSIS AND MENORRHA-GIA (U.S. CLS. 6, 18, 44, 46, 51 AND 52).

MARK RADEMACHER, EXAMINING ATTORNEY

**CLASS 5—(Continued).**

SN 85-160,686. AHHMIGO LLC, NEW YORK, NY. FILED 10-25-2010.

# C-AHH

THE MARK CONSISTS OF STANDARD CHARACTERS WITHOUT CLAIM TO ANY PARTICULAR FONT, STYLE, SIZE, OR COLOR.

FOR NUTRITIONALLY FORTIFIED BEVERAGES AND NUTRITIONAL AND DIETARY SUPPLEMENTS, ALL CONTAINING VITAMIN C (U.S. CLS. 6, 18, 44, 46, 51 AND 52).

LINDSEY RUBIN, EXAMINING ATTORNEY

SN 85-160,605. CAR LABS, LLC, BAKERSFIELD, CA. FILED 10-25-2010.

# SOBER FAST

THE MARK CONSISTS OF STANDARD CHARACTERS WITHOUT CLAIM TO ANY PARTICULAR FONT, STYLE, SIZE, OR COLOR.

NO CLAIM IS MADE TO THE EXCLUSIVE RIGHT TO USE "SOBER", APART FROM THE MARK AS SHOWN.

FOR NUTRITIONAL SUPPLEMENTS (U.S. CLS. 6, 18, 44, 46, 51 AND 52).

FIRST USE 5-11-2010; IN COMMERCE 7-7-2010.

COURTNEY ALVAREZ, EXAMINING ATTORNEY

SN 85-172,732. NU/AG BOSKO, INC., OSKALOOSA, IA. FILED 11-9-2010.

SN 85-160,677. AHHMIGO LLC, NEW YORK, NY. FILED 10-25-2010.



THE MARK CONSISTS OF THE LETTER "C" WITH THE WORD "AHH" SEPARATED BY A HYPHEN WITH A LEAF DESIGN AS PART OF THE TWO "H'S".

FOR NUTRITIONALLY FORTIFIED BEVERAGES AND NUTRITIONAL AND DIETARY SUPPLEMENTS, ALL CONTAINING VITAMIN C (U.S. CLS. 6, 18, 44, 46, 51 AND 52).

LINDSEY RUBIN, EXAMINING ATTORNEY

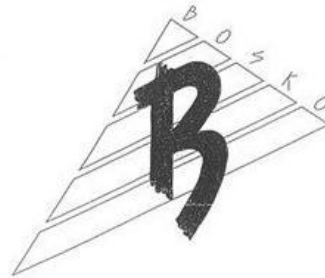

THE MARK CONSISTS OF THE LETTER "B" ON A TRIANGLE WITH LINES ACROSS THE TRIANGLE AND THE WORD "BOSKO" ACROSS THE TOP SIDE OF THE TRIANGLE.

FOR ANIMAL FEED SUPPLEMENTS (U.S. CLS. 6, 18, 44, 46, 51 AND 52).

FIRST USE 5-1-1991; IN COMMERCE 5-1-1991.

DOUGLAS LEE, EXAMINING ATTORNEY

**CLASS 5—(Continued).**

SN 85-172,939. MJ PRODUCTS LLC, DBA O YES, POMPANO BEACH, FL. FILED 11-9-2010.



THE COLOR(S) PINK, RED, WHITE, BLACK AND GRAY IS/ARE CLAIMED AS A FEATURE OF THE MARK.  
THE MARK CONSISTS OF THE WORDING "SWEET BODY SHOTS" IN PINK/RED WITH THE WORD "BODY" HAVING A HEART INSIDE THE "O". THE LETTERS ARE OUTLINED WITH WHITE AND INLINED WITH BLACK. A GRAY SHADOW SURROUNDS EACH OF THE LETTERS.  
FOR WATER-BASED PERSONAL LUBRICANTS (U.S. CLS. 6, 18, 44, 46, 51 AND 52).  
FIRST USE 5-1-2009; IN COMMERCE 6-1-2009.  
MICHAEL ENGEL, EXAMINING ATTORNEY

**CLASS 5—(Continued).**

SN 85-173,750. GREENSTONE LLC, PEAPACK, NJ. FILED 11-10-2010.



OWNER OF U.S. REG. NOS. 1,867,430 AND 3,144,656.  
THE MARK CONSISTS OF THE LETTER "G" INSIDE OF A SQUARE.  
FOR PHARMACEUTICAL PREPARATIONS, NAMELY, A HOUSEMARK FOR A FULL LINE OF PHARMACEUTICAL PREPARATIONS (U.S. CLS. 6, 18, 44, 46, 51 AND 52).  
BRIDGETT SMITH, EXAMINING ATTORNEY

SN 85-172,985. NUTRACEUTICAL RESEARCH GROUP, INC., MEDICINE HAT, CANADA, FILED 11-9-2010.

**Advanced Life Research**

THE MARK CONSISTS OF STANDARD CHARACTERS WITHOUT CLAIM TO ANY PARTICULAR FONT, STYLE, SIZE, OR COLOR.  
FOR NUTRACEUTICALS FOR USE AS A DIETARY SUPPLEMENT (U.S. CLS. 6, 18, 44, 46, 51 AND 52).  
FIRST USE 3-15-2010; IN COMMERCE 3-15-2010.  
MARK T. MULLEN, EXAMINING ATTORNEY

SN 85-174,095. HNS USA INC., FLUSHING, NY. FILED 11-10-2010.

**POWER GINSENG**

THE MARK CONSISTS OF STANDARD CHARACTERS WITHOUT CLAIM TO ANY PARTICULAR FONT, STYLE, SIZE, OR COLOR.  
NO CLAIM IS MADE TO THE EXCLUSIVE RIGHT TO USE "GINSENG", APART FROM THE MARK AS SHOWN.  
FOR NUTRITIONALLY FORTIFIED BEVERAGES CONTAINING GINSENG (U.S. CLS. 6, 18, 44, 46, 51 AND 52).  
FIRST USE 5-21-2010; IN COMMERCE 5-21-2010.  
TIMOTHY FINNEGAN, EXAMINING ATTORNEY

**CLASS 5—(Continued).**

SN 85-174,242. WYETH LLC, MADISON, NJ. FILED 11-11-2010.

# CABILANT

THE MARK CONSISTS OF STANDARD CHARACTERS WITHOUT CLAIM TO ANY PARTICULAR FONT, STYLE, SIZE, OR COLOR.

FOR PHARMACEUTICAL PREPARATIONS FOR THE TREATMENT OF CARDIOVASCULAR, CENTRAL NERVOUS SYSTEM, ENDOCRINE, GASTROINTESTINAL, HEMATOLOGIC, IMMUNOLOGICAL, INFECTIOUS, INFLAMMATORY, MENOPAUSAL, METABOLIC, MUSCULOSKELETAL, NEUROLOGICAL, ONCOLOGICAL, OPHTHALMOLOGICAL, PSYCHIATRIC, RESPIRATORY, UROGENITAL, UROLOGICAL AND VIRAL DISEASES AND DISORDERS; PHARMACEUTICAL PREPARATIONS FOR THE TREATMENT OF ERECTILE DYSFUNCTION, SEXUAL DYSFUNCTION AND PAIN; PHARMACEUTICAL PREPARATIONS, NAMELY, ANTI-FUNGAL PREPARATIONS, DERMATOLOGICAL PREPARATIONS, SMOKING CESSATION PREPARATIONS; VACCINES FOR HUMAN USE (U.S. CLS. 6, 18, 44, 46, 51 AND 52).

WON TEAK OH, EXAMINING ATTORNEY

**CLASS 5—(Continued).**

SN 85-174,519. TAMBRANDS, INC., CINCINNATI, OH. FILED 11-11-2010.

# ANYTHING BUT REGULAR

THE MARK CONSISTS OF STANDARD CHARACTERS WITHOUT CLAIM TO ANY PARTICULAR FONT, STYLE, SIZE, OR COLOR.

FOR TAMPONS (U.S. CLS. 6, 18, 44, 46, 51 AND 52).  
JENNIFER MARTIN, EXAMINING ATTORNEY

SN 85-174,523. TAMBRANDS, INC., CINCINNATI, OH. FILED 11-11-2010.

SN 85-174,501. TAMBRANDS, INC., CINCINNATI, OH. FILED 11-11-2010.

# COMFY 'N LITE

THE MARK CONSISTS OF STANDARD CHARACTERS WITHOUT CLAIM TO ANY PARTICULAR FONT, STYLE, SIZE, OR COLOR.

FOR TAMPONS (U.S. CLS. 6, 18, 44, 46, 51 AND 52).  
JENNIFER MARTIN, EXAMINING ATTORNEY

# SECRETLY SUPER

THE MARK CONSISTS OF STANDARD CHARACTERS WITHOUT CLAIM TO ANY PARTICULAR FONT, STYLE, SIZE, OR COLOR.

FOR TAMPONS (U.S. CLS. 6, 18, 44, 46, 51 AND 52).  
JENNIFER MARTIN, EXAMINING ATTORNEY

SN 85-174,970. CHRISTOPHER COSTELLO, BRONX, NY. FILED 11-11-2010.

SN 85-174,508. TAMBRANDS, INC., CINCINNATI, OH. FILED 11-11-2010.

# READY, CLICK, GO! PROTECTION

THE MARK CONSISTS OF STANDARD CHARACTERS WITHOUT CLAIM TO ANY PARTICULAR FONT, STYLE, SIZE, OR COLOR.

FOR TAMPONS (U.S. CLS. 6, 18, 44, 46, 51 AND 52).  
JENNIFER MARTIN, EXAMINING ATTORNEY

# AI

THE MARK CONSISTS OF STANDARD CHARACTERS WITHOUT CLAIM TO ANY PARTICULAR FONT, STYLE, SIZE, OR COLOR.

FOR PHARMACEUTICAL PREPARATIONS FOR TREATMENT OF COLDS; PREPARATIONS FOR TREATING COLDS (U.S. CLS. 6, 18, 44, 46, 51 AND 52).  
JULIE VEPPUMTHARA, EXAMINING ATTORNEY

**CLASS 5—(Continued).**

SN 85-175,103. CAPRICOR, INC., LOS ANGELES, CA. FILED 11-11-2010.

# CELLICOR

THE MARK CONSISTS OF STANDARD CHARACTERS WITHOUT CLAIM TO ANY PARTICULAR FONT, STYLE, SIZE, OR COLOR.

FOR BIOLOGICAL CARDIAC TISSUE INTENDED FOR SUBSEQUENT IMPLANTATION; CARDIOVASCULAR TREATMENT PREPARATIONS; HUMAN ALLOGRAFT TISSUE; IMPLANTS COMPRISING LIVING TISSUE (U.S. CLS. 6, 18, 44, 46, 51 AND 52).

ANDREA BUTLER, EXAMINING ATTORNEY

**CLASS 5—(Continued).**

SN 85-175,958. LIFE FACTOR RESEARCH LLC, LA QUINTA, CA. FILED 11-12-2010.

# SomniSure

THE MARK CONSISTS OF STANDARD CHARACTERS WITHOUT CLAIM TO ANY PARTICULAR FONT, STYLE, SIZE, OR COLOR.

FOR DIETARY AND NUTRITIONAL SUPPLEMENTS (U.S. CLS. 6, 18, 44, 46, 51 AND 52).

SAMUEL E. SHARPER JR., EXAMINING ATTORNEY

SN 85-175,373. PREMIUM INGREDIENTS INTERNATIONAL (US) LLC, CAROL STREAM, IL. FILED 11-12-2010.

# AminoNOX

THE MARK CONSISTS OF STANDARD CHARACTERS WITHOUT CLAIM TO ANY PARTICULAR FONT, STYLE, SIZE, OR COLOR.

FOR AMINO ACIDS FOR NUTRITIONAL PURPOSES (U.S. CLS. 6, 18, 44, 46, 51 AND 52).

FIRST USE 10-20-2010; IN COMMERCE 10-20-2010.

JUDITH HELFMAN, EXAMINING ATTORNEY

SN 85-176,004. MARZ, KEITH, VAN NUYS, CA. FILED 11-12-2010.

# C-SPRAY

THE MARK CONSISTS OF STANDARD CHARACTERS WITHOUT CLAIM TO ANY PARTICULAR FONT, STYLE, SIZE, OR COLOR.

FOR VITAMIN C PREPARATIONS (U.S. CLS. 6, 18, 44, 46, 51 AND 52).

FIRST USE 4-1-2010; IN COMMERCE 4-1-2010.

KAREN SEVERSON, EXAMINING ATTORNEY

SN 85-175,808. CENTRIX, INC., SHELTON, CT. FILED 11-12-2010.

# CHAMP

THE MARK CONSISTS OF STANDARD CHARACTERS WITHOUT CLAIM TO ANY PARTICULAR FONT, STYLE, SIZE, OR COLOR.

FOR DENTAL SEALANTS (U.S. CLS. 6, 18, 44, 46, 51 AND 52).

PAUL MORENO, EXAMINING ATTORNEY

SN 85-176,044. MARLYN NUTRACEUTICALS, INC., DBA NATURALLY VITAMINS, PHOENIX, AZ. FILED 11-12-2010.

# GLOWFIZZ

THE MARK CONSISTS OF STANDARD CHARACTERS WITHOUT CLAIM TO ANY PARTICULAR FONT, STYLE, SIZE, OR COLOR.

FOR DIETARY AND NUTRITIONAL SUPPLEMENTS; HERBAL SUPPLEMENTS; MINERAL SUPPLEMENTS; NUTRACEUTICALS FOR USE AS A DIETARY SUPPLEMENT; NUTRITIONAL SUPPLEMENTS FOR PROMOTING HEALTHY SKIN; POWDERED FRUIT-FLAVORED DIETARY SUPPLEMENT DRINK MIX; POWDERED NUTRITIONAL SUPPLEMENT DRINK MIX; VITAMIN AND MINERAL SUPPLEMENTS; VITAMIN SUPPLEMENT IN TABLET FORM FOR USE IN MAKING AN EFFERVESCENT BEVERAGE WHEN ADDED TO WATER (U.S. CLS. 6, 18, 44, 46, 51 AND 52).

DOMINIC J. FERRAIUOLO, EXAMINING ATTORNEY



**CLASS 5—(Continued).**

SN 85-176,456. THE YANKEE CANDLE COMPANY, INC., SOUTH DEERFIELD, MA. FILED 11-15-2010.

**AUTUMN LEAVES**

THE MARK CONSISTS OF STANDARD CHARACTERS WITHOUT CLAIM TO ANY PARTICULAR FONT, STYLE, SIZE, OR COLOR.

FOR AIR FRESHENERS (U.S. CLS. 6, 18, 44, 46, 51 AND 52).

FIRST USE 6-4-2008; IN COMMERCE 6-4-2008.  
HANNO RITTNER, EXAMINING ATTORNEY

**CLASS 5—(Continued).**

SN 85-176,847. THE ARENSON GROUP INC, ORLANDO, FL. FILED 11-15-2010.

**Stannex**

THE MARK CONSISTS OF STANDARD CHARACTERS WITHOUT CLAIM TO ANY PARTICULAR FONT, STYLE, SIZE, OR COLOR.

FOR PHARMACEUTICAL PREPARATIONS FOR THE TREATMENT AND PREVENTION OF VIRAL AND FUNGAL INFECTIONS (U.S. CLS. 6, 18, 44, 46, 51 AND 52).

FIRST USE 1-31-2010; IN COMMERCE 1-31-2010.  
SANJEEV VOHRA, EXAMINING ATTORNEY

SN 85-176,606. SUNRISE GLOBAL CORP, MIAMI, FL. FILED 11-15-2010.



THE MARK CONSISTS OF THE WORDS "VARI" AND "THIN" IN A LOWERCASE STYLIZED FONT. A CURVE LINE PASSING BEHIND THE WORDS "VARI" AND "THIN". THERE IS A DASH BETWEEN THE WORDS "VARI" AND "THIN".

FOR NUTRITIONAL SUPPLEMENTS (U.S. CLS. 6, 18, 44, 46, 51 AND 52).

FIRST USE 2-5-2008; IN COMMERCE 2-5-2008.  
CURTIS FRENCH, EXAMINING ATTORNEY

SN 85-177,355. SENA PRODUCTS, LLC, EL SEGUNDO, CA. FILED 11-15-2010.

**SPRINKLE AWAY THE POUNDS**

THE MARK CONSISTS OF STANDARD CHARACTERS WITHOUT CLAIM TO ANY PARTICULAR FONT, STYLE, SIZE, OR COLOR.

FOR NUTRITIONAL ADDITIVES FOR WEIGHT LOSS AND WEIGHT MANAGEMENT FOR USE IN OR ON FOODS (U.S. CLS. 6, 18, 44, 46, 51 AND 52).

RONALD MCMORROW, EXAMINING ATTORNEY

SN 85-176,718. PBM PHARMACEUTICALS, INC., GORDONSVILLE, VA. FILED 11-15-2010.

**ANIMI-3D**

THE MARK CONSISTS OF STANDARD CHARACTERS WITHOUT CLAIM TO ANY PARTICULAR FONT, STYLE, SIZE, OR COLOR.

OWNER OF U.S. REG. NOS. 2,940,632 AND 2,940,637.  
FOR PRESCRIPTION FOLIC ACID SUPPLEMENTS; FOLIC ACID DIETARY SUPPLEMENTS; DIETARY SUPPLEMENTS (U.S. CLS. 6, 18, 44, 46, 51 AND 52).

C. DIONNE CLYBURN, EXAMINING ATTORNEY

SN 85-177,356. SENA PRODUCTS LLC, EL SEGUNDO, CA. FILED 11-15-2010.

**SHAKE AWAY THE POUNDS**

THE MARK CONSISTS OF STANDARD CHARACTERS WITHOUT CLAIM TO ANY PARTICULAR FONT, STYLE, SIZE, OR COLOR.

FOR DIETARY FOOD SUPPLEMENTS; NUTRITIONAL ADDITIVES FOR WEIGHT LOSS AND WEIGHT MANAGEMENT FOR USE IN OR ON FOODS; AND DIETARY SUPPLEMENTS FOR HUMAN CONSUMPTION (U.S. CLS. 6, 18, 44, 46, 51 AND 52).

RONALD MCMORROW, EXAMINING ATTORNEY

**CLASS 5—(Continued).**

SN 85-177,654. THE CLOROX COMPANY, OAKLAND, CA. FILED 11-16-2010.

## Refreshing Breeze

THE MARK CONSISTS OF STANDARD CHARACTERS WITHOUT CLAIM TO ANY PARTICULAR FONT, STYLE, SIZE, OR COLOR.

FOR CHEMICAL PREPARATIONS TO TREAT MILDEW (U.S. CLS. 6, 18, 44, 46, 51 AND 52).  
AMY ALFIERI, EXAMINING ATTORNEY

**CLASS 5—(Continued).**

SN 85-178,057. LIPTIS PHARMACEUTICALS USA, INC., SPRING VALLEY, NY. FILED 11-16-2010.

## DOROFEN

THE MARK CONSISTS OF STANDARD CHARACTERS WITHOUT CLAIM TO ANY PARTICULAR FONT, STYLE, SIZE, OR COLOR.

FOR PHARMACEUTICAL PREPARATIONS FOR THE TREATMENT AND PREVENTION OF OSTEOARTHRITIS (U.S. CLS. 6, 18, 44, 46, 51 AND 52).

FIRST USE 10-4-1999; IN COMMERCE 10-4-1999.  
ELLEN B. AWRICH, EXAMINING ATTORNEY

SN 85-177,759. GREEN EARTH NATURALLY, LLC, DBA EARTHCLEANZ, ROANOKE, VA. FILED 11-16-2010.

## EcoCal

THE MARK CONSISTS OF STANDARD CHARACTERS WITHOUT CLAIM TO ANY PARTICULAR FONT, STYLE, SIZE, OR COLOR.

FOR ANIMAL FEED SUPPLEMENTS; DIETARY SUPPLEMENTS FOR ANIMALS; FEED SUPPLEMENTS FOR MONOGASTRIC LIVESTOCK AND PETS (U.S. CLS. 6, 18, 44, 46, 51 AND 52).

FIRST USE 6-15-2004; IN COMMERCE 11-23-2004.  
WON TEAK OH, EXAMINING ATTORNEY

SN 85-178,105. ECPRO INCORPORATED, DBA ECIGPROS, LAND O LAKES, FL. FILED 11-16-2010.

## eCigPros

THE MARK CONSISTS OF STANDARD CHARACTERS WITHOUT CLAIM TO ANY PARTICULAR FONT, STYLE, SIZE, OR COLOR.

FOR IMITATION CIGARETTES FOR QUITTING SMOKING; TOBACCO-FREE CIGARETTES FOR MEDICAL PURPOSES (U.S. CLS. 6, 18, 44, 46, 51 AND 52).

FIRST USE 5-1-2009; IN COMMERCE 5-1-2009.  
JANICE KIM, EXAMINING ATTORNEY

SN 85-177,916. ELORAC, INC, VERNON HILLS, IL. FILED 11-16-2010.

## VIRASAL

THE MARK CONSISTS OF STANDARD CHARACTERS WITHOUT CLAIM TO ANY PARTICULAR FONT, STYLE, SIZE, OR COLOR.

FOR DERMATOLOGICAL PHARMACEUTICAL PRODUCTS (U.S. CLS. 6, 18, 44, 46, 51 AND 52).

JOHN WILKE, EXAMINING ATTORNEY

SN 85-178,190. ISTA PHARMACEUTICALS, INC., IRVINE, CA. FILED 11-16-2010.

## THE POWER OF ONE

THE MARK CONSISTS OF STANDARD CHARACTERS WITHOUT CLAIM TO ANY PARTICULAR FONT, STYLE, SIZE, OR COLOR.

FOR PHARMACEUTICAL PREPARATIONS FOR THE TREATMENT OF OPHTHALMIC DISEASES AND CONDITIONS (U.S. CLS. 6, 18, 44, 46, 51 AND 52).

DOMINICK J. SALEMI, EXAMINING ATTORNEY

**CLASS 5—(Continued).**

SN 85-178,212. KINETIX LIVING CORP., SEATTLE, WA.  
FILED 11-16-2010.

Rebel. Ignite. Commit.

THE MARK CONSISTS OF STANDARD CHARACTERS WITHOUT CLAIM TO ANY PARTICULAR FONT, STYLE, SIZE, OR COLOR.

FOR DIETARY SUPPLEMENTS; NUTRITIONAL SUPPLEMENTS; DIETARY DRINK MIXES FOR USE AS A MEAL REPLACEMENT; MEAL REPLACEMENT AND DIETARY SUPPLEMENT DRINKS; NUTRITIONAL SUPPLEMENTS IN LIQUID, POWDER, AND BAR FORM, DESIGNED TO HELP FULFILL DIETARY REQUIREMENTS; NUTRITIONAL SUPPLEMENT BARS; NUTRITIONAL SHAKES FOR USE AS A MEAL SUBSTITUTE; NUTRITIONAL MEAL REPLACEMENT PRODUCTS, NAMELY, MEAL REPLACEMENT BARS, MEAL REPLACEMENT POWDERS, AND MEAL REPLACEMENT DRINKS (U.S. CLS. 6, 18, 44, 46, 51 AND 52).

GIANCARLO CASTRO, EXAMINING ATTORNEY

SN 85-178,373. TIKKUN LLC, SAN DIEGO, CA. FILED 11-16-2010.

BONADOXINA

THE MARK CONSISTS OF STANDARD CHARACTERS WITHOUT CLAIM TO ANY PARTICULAR FONT, STYLE, SIZE, OR COLOR.

FOR TREATMENT AND PREVENTION OF NAUSEA PREPARATIONS (U.S. CLS. 6, 18, 44, 46, 51 AND 52).

TRACY WHITTAKER-BROWN, EXAMINING ATTORNEY

SN 85-178,422. FAB HOLDINGS, WESLEY CHAPEL, FL.  
FILED 11-16-2010.

Less Stress More Fun

THE MARK CONSISTS OF STANDARD CHARACTERS WITHOUT CLAIM TO ANY PARTICULAR FONT, STYLE, SIZE, OR COLOR.

FOR VITAMIN ENRICHED WATER (U.S. CLS. 6, 18, 44, 46, 51 AND 52).

FIRST USE 9-29-2010; IN COMMERCE 9-29-2010.  
LAKEISHA LEWIS, EXAMINING ATTORNEY

**CLASS 5—(Continued).**

SN 85-178,448. BONDIA LABS, INC., TIBURON, CA. FILED 11-16-2010.

OsteoActive

THE MARK CONSISTS OF STANDARD CHARACTERS WITHOUT CLAIM TO ANY PARTICULAR FONT, STYLE, SIZE, OR COLOR.

FOR DIETARY AND NUTRITIONAL SUPPLEMENTS (U.S. CLS. 6, 18, 44, 46, 51 AND 52).

CAROLYN CATALDO, EXAMINING ATTORNEY

SN 85-178,524. WINDMILL HEALTH PRODUCTS LLC,  
WEST CALDWELL, NJ. FILED 11-17-2010.

GOJISPLASH

THE MARK CONSISTS OF STANDARD CHARACTERS WITHOUT CLAIM TO ANY PARTICULAR FONT, STYLE, SIZE, OR COLOR.

FOR DIETARY AND NUTRITIONAL SUPPLEMENTS (U.S. CLS. 6, 18, 44, 46, 51 AND 52).

SANI KHOURI, EXAMINING ATTORNEY

SN 85-178,705. GLAXO GROUP LIMITED, GREENFORD,  
MIDDLESEX, UNITED KINGDOM, FILED 11-17-2010.

SUNVERO

THE MARK CONSISTS OF STANDARD CHARACTERS WITHOUT CLAIM TO ANY PARTICULAR FONT, STYLE, SIZE, OR COLOR.

FOR PHARMACEUTICAL PREPARATIONS AND SUBSTANCES FOR THE TREATMENT OF DAMAGED SKIN AND TISSUE; PHARMACEUTICAL PREPARATIONS AND SUBSTANCES FOR THE TREATMENT OF INFECTIOUS DISEASES, BLOOD DISORDERS, PAIN, INFLAMMATION, SEPSIS, ALOPECIA, OBESITY AND COGNITIVE DISORDERS; PHARMACEUTICAL PREPARATIONS AND SUBSTANCES FOR THE TREATMENT OF VIRAL, METABOLIC, ENDOCRINE, MUSCULOSKELETAL, CARDIOVASCULAR, CARDIOPULMONARY, GENITOURINARY, SEXUAL DYSFUNCTION, ONCOLOGICAL, HEPATOLOGICAL, OPHTHALMIC, RESPIRATORY, NEUROLOGICAL, GASTROINTESTINAL, HORMONAL, DERMATOLOGICAL, PSYCHIATRIC AND IMMUNE SYSTEM RELATED DISEASES AND DISORDERS; VACCINES (U.S. CLS. 6, 18, 44, 46, 51 AND 52).

BARBARA GAYNOR, EXAMINING ATTORNEY

**CLASS 5—(Continued).**

SN 85-178,711. GLAXO GROUP LIMITED, GREENFORD, MIDDLESEX, UNITED KINGDOM, FILED 11-17-2010.

**VRUYOME**

THE MARK CONSISTS OF STANDARD CHARACTERS WITHOUT CLAIM TO ANY PARTICULAR FONT, STYLE, SIZE, OR COLOR.

THE WORDING "VRUYOME" HAS NO MEANING IN A FOREIGN LANGUAGE.

FOR PHARMACEUTICAL PREPARATIONS AND SUBSTANCES FOR THE TREATMENT OF DAMAGED SKIN AND TISSUE; PHARMACEUTICAL PREPARATIONS AND SUBSTANCES FOR THE TREATMENT OF INFECTIOUS DISEASES, BLOOD DISORDERS, PAIN, INFLAMMATION, SEPSIS, ALOPECIA, OBESITY AND COGNITIVE DISORDERS; PHARMACEUTICAL PREPARATIONS AND SUBSTANCES FOR THE TREATMENT OF VIRAL, METABOLIC, ENDOCRINE, MUSCULOSKELETAL, CARDIOVASCULAR, CARDIOPULMONARY, GENITOURINARY, SEXUAL DYSFUNCTION, ONCOLOGICAL, HEPATOLOGICAL, OPHTHALMIC, RESPIRATORY, NEUROLOGICAL, GASTROINTESTINAL, HORMONAL, DERMATOLOGICAL, PSYCHIATRIC AND IMMUNE SYSTEM RELATED DISEASES AND DISORDERS; VACCINES (U.S. CLS. 6, 18, 44, 46, 51 AND 52).

BARBARA GAYNOR, EXAMINING ATTORNEY

SN 85-178,712. GLAXO GROUP LIMITED, GREENFORD, MIDDLESEX, UNITED KINGDOM, FILED 11-17-2010.

**ZAJANE**

THE MARK CONSISTS OF STANDARD CHARACTERS WITHOUT CLAIM TO ANY PARTICULAR FONT, STYLE, SIZE, OR COLOR.

THE WORDING "ZAJANE" HAS NO MEANING IN A FOREIGN LANGUAGE.

FOR PHARMACEUTICAL PREPARATIONS AND SUBSTANCES FOR THE TREATMENT OF DAMAGED SKIN AND TISSUE; PHARMACEUTICAL PREPARATIONS AND SUBSTANCES FOR THE TREATMENT OF INFECTIOUS DISEASES, BLOOD DISORDERS, PAIN, INFLAMMATION, SEPSIS, ALOPECIA, OBESITY AND COGNITIVE DISORDERS; PHARMACEUTICAL PREPARATIONS AND SUBSTANCES FOR THE TREATMENT OF VIRAL, METABOLIC, ENDOCRINE, MUSCULOSKELETAL, CARDIOVASCULAR, CARDIOPULMONARY, GENITOURINARY, SEXUAL DYSFUNCTION, ONCOLOGICAL, HEPATOLOGICAL, OPHTHALMIC, RESPIRATORY, NEUROLOGICAL, GASTROINTESTINAL, HORMONAL, DERMATOLOGICAL, PSYCHIATRIC AND IMMUNE SYSTEM RELATED DISEASES AND DISORDERS; VACCINES (U.S. CLS. 6, 18, 44, 46, 51 AND 52).

BARBARA GAYNOR, EXAMINING ATTORNEY

**CLASS 5—(Continued).**

SN 85-178,752. MONOGRAM BIOSCIENCES, INC., SOUTH SAN FRANCISCO, CA. FILED 11-17-2010.

**TROPOSEQ**

THE MARK CONSISTS OF STANDARD CHARACTERS WITHOUT CLAIM TO ANY PARTICULAR FONT, STYLE, SIZE, OR COLOR.

FOR MEDICAL DIAGNOSTIC ASSAYS FOR VIRAL TESTING (U.S. CLS. 6, 18, 44, 46, 51 AND 52).

KATHERINE STOIDES, EXAMINING ATTORNEY

SN 85-178,925. HCG PLATINUM, LLC, PROVO, UT. FILED 11-17-2010.

**TOTAL HCG**

THE MARK CONSISTS OF STANDARD CHARACTERS WITHOUT CLAIM TO ANY PARTICULAR FONT, STYLE, SIZE, OR COLOR.

NO CLAIM IS MADE TO THE EXCLUSIVE RIGHT TO USE "HCG", APART FROM THE MARK AS SHOWN.

FOR HOMEOPATHIC SUPPLEMENTS AND NUTRITIONAL PREPARATIONS FOR USE IN WEIGHT MANAGEMENT AND DIETING; VITAMINS, HERBS AND MINERALS FOR USE AS DIETARY AND NUTRITIONAL SUPPLEMENTS; NUTRITIONAL SUPPLEMENTS FOR USE AS A MEAL REPLACEMENT; DIETING PILLS AND POWDER PREPARATIONS TO PROMOTE WEIGHT LOSS; ALL THE AFOREMENTIONED GOODS CONTAIN OR DIRECTLY PROMOTE THE PRODUCTION OF HUMAN CHORIONIC GONADOTROPHIN (HCG) (U.S. CLS. 6, 18, 44, 46, 51 AND 52).

GINA FINK, EXAMINING ATTORNEY

**CLASS 5—(Continued).**

SN 85-179,001. GLAXO GROUP LIMITED, GREENFORD, MIDDLESEX, UNITED KINGDOM, FILED 11-17-2010.

**DURAPURE**

THE MARK CONSISTS OF STANDARD CHARACTERS WITHOUT CLAIM TO ANY PARTICULAR FONT, STYLE, SIZE, OR COLOR.

FOR PHARMACEUTICAL PREPARATIONS AND SUBSTANCES FOR THE TREATMENT OF INFECTIOUS DISEASES, BLOOD DISORDERS, PAIN, INFLAMMATION, SEPSIS, ALOPECIA, OBESITY AND COGNITIVE DISORDERS; PHARMACEUTICAL PREPARATIONS AND SUBSTANCES FOR THE TREATMENT OF VIRAL, METABOLIC, ENDOCRINE, MUSCULOSKELETAL, CARDIOVASCULAR, CARDIOPULMONARY, GENITOURINARY, SEXUAL DYSFUNCTION, ONCOLOGICAL, HEPATOLOGICAL, OPHTHALMIC, RESPIRATORY, NEUROLOGICAL, GASTROINTESTINAL, HORMONAL, DERMATOLOGICAL, PSYCHIATRIC AND IMMUNE SYSTEM RELATED DISEASES AND DISORDERS; PHARMACEUTICAL PREPARATIONS AND SUBSTANCES FOR THE TREATMENT OF DAMAGED SKIN AND TISSUE; AND FOR VACCINES (U.S. CLS. 6, 18, 44, 46, 51 AND 52).

BARBARA GAYNOR, EXAMINING ATTORNEY

**CLASS 5—(Continued).**

SN 85-179,269. NOVARTIS AG, BASEL, SWITZERLAND, FILED 11-17-2010.

**VAXAFLU**

THE MARK CONSISTS OF STANDARD CHARACTERS WITHOUT CLAIM TO ANY PARTICULAR FONT, STYLE, SIZE, OR COLOR.

PRIORITY CLAIMED UNDER SEC. 44(D) ON SWITZERLAND APPLICATION NO. 58096/2010, FILED 8-3-2010, REG. NO. 603626, DATED 8-9-2010, EXPIRES 8-3-2020.

FOR VACCINES FOR HUMAN USE (U.S. CLS. 6, 18, 44, 46, 51 AND 52).

MATTHEW KLINE, EXAMINING ATTORNEY

SN 85-179,181. GOOD THINGS HEALTH, LLC, KANSAS CITY, MO. FILED 11-17-2010.

**DEVELOPED BY  
CARDIOLOGISTS. TRUSTED BY  
DOCTORS.**

THE MARK CONSISTS OF STANDARD CHARACTERS WITHOUT CLAIM TO ANY PARTICULAR FONT, STYLE, SIZE, OR COLOR.

FOR VITAMINS; NUTRITIONAL SUPPLEMENTS; DIETARY SUPPLEMENTS (U.S. CLS. 6, 18, 44, 46, 51 AND 52).

FIRST USE 8-30-2010; IN COMMERCE 8-30-2010.  
CAROLINE WOOD, EXAMINING ATTORNEY

SN 85-179,328. NEW ENGLAND GREENS, LLC, CANAAN, CT. FILED 11-17-2010.

**TRUTH, TRUST AND  
TRANSPARENCY**

THE MARK CONSISTS OF STANDARD CHARACTERS WITHOUT CLAIM TO ANY PARTICULAR FONT, STYLE, SIZE, OR COLOR.

FOR NUTRITIONAL SUPPLEMENTS (U.S. CLS. 6, 18, 44, 46, 51 AND 52).

BARBARA RUTLAND, EXAMINING ATTORNEY

SN 85-179,248. HEALTH SCIENCE DISTRIBUTORS, CO., ASHEVILLE, NC. FILED 11-17-2010.

**SERENITY**

THE MARK CONSISTS OF STANDARD CHARACTERS WITHOUT CLAIM TO ANY PARTICULAR FONT, STYLE, SIZE, OR COLOR.

FOR PHARMACEUTICAL PREPARATION FOR THE TREATMENT OF HORMONAL DISORDERS AND THE PREVENTION OF OSTEOPOROSIS; NATURAL PROGESTERONE CREAM (U.S. CLS. 6, 18, 44, 46, 51 AND 52).

FIRST USE 0-0-1995; IN COMMERCE 0-0-1995.  
NICHOLAS COLEMAN, EXAMINING ATTORNEY

SN 85-179,362. NOVARTIS AG, BASEL, SWITZERLAND, FILED 11-17-2010.

**VAXOFLU**

THE MARK CONSISTS OF STANDARD CHARACTERS WITHOUT CLAIM TO ANY PARTICULAR FONT, STYLE, SIZE, OR COLOR.

PRIORITY CLAIMED UNDER SEC. 44(D) ON SWITZERLAND APPLICATION NO. 58094/2010, FILED 8-3-2010, REG. NO. 603625, DATED 8-9-2010, EXPIRES 8-3-2020.

FOR VACCINES FOR HUMAN USE (U.S. CLS. 6, 18, 44, 46, 51 AND 52).

MATTHEW KLINE, EXAMINING ATTORNEY

**CLASS 5—(Continued).**

SN 85-179,389. NOVARTIS AG, BASEL, SWITZERLAND, FILED 11-17-2010.

# VIFLUAN

THE MARK CONSISTS OF STANDARD CHARACTERS WITHOUT CLAIM TO ANY PARTICULAR FONT, STYLE, SIZE, OR COLOR.

PRIORITY CLAIMED UNDER SEC. 44(D) ON SWITZERLAND APPLICATION NO. 60361/2010, FILED 9-30-2010, REG. NO. 606282, DATED 10-7-2010, EXPIRES 9-30-2020.

FOR VACCINES FOR HUMAN USE (U.S. CLS. 6, 18, 44, 46, 51 AND 52).

MATTHEW KLINE, EXAMINING ATTORNEY

---

SN 85-180,223. DICKEY INVESTMENTS, LLC, NOBLESVILLE, IN. FILED 11-18-2010.

# Dickey's

THE MARK CONSISTS OF STANDARD CHARACTERS WITHOUT CLAIM TO ANY PARTICULAR FONT, STYLE, SIZE, OR COLOR.

FOR PAIN RELIEF MEDICATION (U.S. CLS. 6, 18, 44, 46, 51 AND 52).

SUNG IN, EXAMINING ATTORNEY

---

SN 85-181,172. UNITED LABORATORIES, INC., ST. CHARLES, IL. FILED 11-19-2010.

# CYCLE SMART

THE MARK CONSISTS OF STANDARD CHARACTERS WITHOUT CLAIM TO ANY PARTICULAR FONT, STYLE, SIZE, OR COLOR.

FOR ALGAECIDE, BACTERICIDE, AND FUNGICIDE, FOR THE CONTROL OF ALGAE, SLIME FORMING BACTERIA, SULFATE REDUCING BACTERIA, AND FUNGI IN INDUSTRIAL SYSTEMS, INCLUDING AIR-WASHERS AND INDUSTRIAL AIR SCRUBBING SYSTEMS, RECIRCULATING COOLING WATER AND PROCESS WATER SYSTEMS, AND ENHANCED OIL RECOVERY SYSTEMS (U.S. CLS. 6, 18, 44, 46, 51 AND 52).

FIRST USE 4-22-2010; IN COMMERCE 4-22-2010.  
TARAH HARDY, EXAMINING ATTORNEY

**CLASS 5—(Continued).**

SN 85-181,535. LORNA VANDERHAEGHE HEALTH SOLUTIONS, INC., VANCOUVER, BC, CANADA, FILED 11-19-2010.

# Lipofe

THE MARK CONSISTS OF STANDARD CHARACTERS WITHOUT CLAIM TO ANY PARTICULAR FONT, STYLE, SIZE, OR COLOR.

FOR DIETARY AND NUTRITIONAL SUPPLEMENTS (U.S. CLS. 6, 18, 44, 46, 51 AND 52).

KIM MONINGHOFF, EXAMINING ATTORNEY

---

SN 85-182,414. GLAXO GROUP LIMITED, GREENFORD, MIDDLESEX, UNITED KINGDOM, FILED 11-22-2010.

# DECTROME

THE MARK CONSISTS OF STANDARD CHARACTERS WITHOUT CLAIM TO ANY PARTICULAR FONT, STYLE, SIZE, OR COLOR.

FOR PHARMACEUTICAL PREPARATIONS AND SUBSTANCES FOR THE TREATMENT OF DAMAGED SKIN AND TISSUE; PHARMACEUTICAL PREPARATIONS AND SUBSTANCES FOR THE TREATMENT OF INFECTIOUS DISEASES, BLOOD DISORDERS, PAIN, INFLAMMATION, SEPSIS, ALOPECIA, OBESITY AND COGNITIVE DISORDERS; PHARMACEUTICAL PREPARATIONS AND SUBSTANCES FOR THE TREATMENT OF VIRAL, METABOLIC, ENDOCRINE, MUSCULOSKELETAL, CARDIOVASCULAR, CARDIO-PULMONARY, GENITOURINARY, SEXUAL DYSFUNCTION, ONCOLOGICAL, HEPATOLOGICAL, OPHTHALMIC, RESPIRATORY, NEUROLOGICAL, GASTROINTESTINAL, HORMONAL, DERMATOLOGICAL, PSYCHIATRIC AND IMMUNE SYSTEM RELATED DISEASES AND DISORDERS; VACCINES (U.S. CLS. 6, 18, 44, 46, 51 AND 52).

BARBARA GAYNOR, EXAMINING ATTORNEY

**CLASS 5—(Continued).**

SN 85-182,423. GLAXO GROUP LIMITED, GREENFORD, MIDDLESEX, UNITED KINGDOM, FILED 11-22-2010.

# XECULA

THE MARK CONSISTS OF STANDARD CHARACTERS WITHOUT CLAIM TO ANY PARTICULAR FONT, STYLE, SIZE, OR COLOR.

THE WORDING "XECULA" HAS NO MEANING IN A FOREIGN LANGUAGE.

FOR PHARMACEUTICAL PREPARATIONS AND SUBSTANCES FOR THE TREATMENT OF DAMAGED SKIN AND TISSUE; PHARMACEUTICAL PREPARATIONS AND SUBSTANCES FOR THE TREATMENT OF INFECTIOUS DISEASES, BLOOD DISORDERS, PAIN, INFLAMMATION, SEPSIS, ALOPECIA, OBESITY AND COGNITIVE DISORDERS; PHARMACEUTICAL PREPARATIONS AND SUBSTANCES FOR THE TREATMENT OF VIRAL, METABOLIC, ENDOCRINE, MUSCULOSKELETAL, CARDIOVASCULAR, CARDIOPULMONARY, GENITOURINARY, SEXUAL DYSFUNCTION, ONCOLOGICAL, HEPATOLOGICAL, OPHTHALMIC, RESPIRATORY, NEUROLOGICAL, GASTROINTESTINAL, HORMONAL, DERMATOLOGICAL, PSYCHIATRIC AND IMMUNE SYSTEM RELATED DISEASES AND DISORDERS; VACCINES (U.S. CLS. 6, 18, 44, 46, 51 AND 52).

BARBARA GAYNOR, EXAMINING ATTORNEY

**CLASS 5—(Continued).**

SN 85-182,431. GLAXO GROUP LIMITED, GREENFORD, MIDDLESEX, UNITED KINGDOM, FILED 11-22-2010.

# ECCLECT

THE MARK CONSISTS OF STANDARD CHARACTERS WITHOUT CLAIM TO ANY PARTICULAR FONT, STYLE, SIZE, OR COLOR.

FOR PHARMACEUTICAL PREPARATIONS AND SUBSTANCES FOR THE TREATMENT OF DAMAGED SKIN AND TISSUE; PHARMACEUTICAL PREPARATIONS AND SUBSTANCES FOR THE TREATMENT OF INFECTIOUS DISEASES, BLOOD DISORDERS, PAIN, INFLAMMATION, SEPSIS, ALOPECIA, OBESITY AND COGNITIVE DISORDERS; PHARMACEUTICAL PREPARATIONS AND SUBSTANCES FOR THE TREATMENT OF VIRAL, METABOLIC, ENDOCRINE, MUSCULOSKELETAL, CARDIOVASCULAR, CARDIOPULMONARY, GENITOURINARY, SEXUAL DYSFUNCTION, ONCOLOGICAL, HEPATOLOGICAL, OPHTHALMIC, RESPIRATORY, NEUROLOGICAL, GASTROINTESTINAL, HORMONAL, DERMATOLOGICAL, PSYCHIATRIC AND IMMUNE SYSTEM RELATED DISEASES AND DISORDERS; VACCINES (U.S. CLS. 6, 18, 44, 46, 51 AND 52).

BARBARA GAYNOR, EXAMINING ATTORNEY

SN 85-182,427. GLAXO GROUP LIMITED, GREENFORD, MIDDLESEX, UNITED KINGDOM, FILED 11-22-2010.

# GLASARI

THE MARK CONSISTS OF STANDARD CHARACTERS WITHOUT CLAIM TO ANY PARTICULAR FONT, STYLE, SIZE, OR COLOR.

THE WORDING "GLASARI" HAS NO MEANING IN A FOREIGN LANGUAGE.

FOR PHARMACEUTICAL PREPARATIONS AND SUBSTANCES FOR THE TREATMENT OF DAMAGED SKIN AND TISSUE; PHARMACEUTICAL PREPARATIONS AND SUBSTANCES FOR THE TREATMENT OF INFECTIOUS DISEASES, BLOOD DISORDERS, PAIN, INFLAMMATION, SEPSIS, ALOPECIA, OBESITY AND COGNITIVE DISORDERS; PHARMACEUTICAL PREPARATIONS AND SUBSTANCES FOR THE TREATMENT OF VIRAL, METABOLIC, ENDOCRINE, MUSCULOSKELETAL, CARDIOVASCULAR, CARDIOPULMONARY, GENITOURINARY, SEXUAL DYSFUNCTION, ONCOLOGICAL, HEPATOLOGICAL, OPHTHALMIC, RESPIRATORY, NEUROLOGICAL, GASTROINTESTINAL, HORMONAL, DERMATOLOGICAL, PSYCHIATRIC AND IMMUNE SYSTEM RELATED DISEASES AND DISORDERS; VACCINES (U.S. CLS. 6, 18, 44, 46, 51 AND 52).

BARBARA GAYNOR, EXAMINING ATTORNEY

SN 85-182,434. GLAXO GROUP LIMITED, GREENFORD, MIDDLESEX, UNITED KINGDOM, FILED 11-22-2010.

# RINISTA

THE MARK CONSISTS OF STANDARD CHARACTERS WITHOUT CLAIM TO ANY PARTICULAR FONT, STYLE, SIZE, OR COLOR.

OWNER OF UNITED KINGDOM REG. NO. 2543174, DATED 3-26-2010, EXPIRES 3-26-2020.

THE WORDING "RINISTA" HAS NO MEANING IN A FOREIGN LANGUAGE.

FOR PHARMACEUTICAL PREPARATIONS AND SUBSTANCES FOR THE TREATMENT OF DAMAGED SKIN AND TISSUE; PHARMACEUTICAL PREPARATIONS AND SUBSTANCES FOR THE TREATMENT OF INFECTIOUS DISEASES, BLOOD DISORDERS, PAIN, INFLAMMATION, SEPSIS, ALOPECIA, OBESITY AND COGNITIVE DISORDERS; PHARMACEUTICAL PREPARATIONS AND SUBSTANCES FOR THE TREATMENT OF VIRAL, METABOLIC, ENDOCRINE, MUSCULOSKELETAL, CARDIOVASCULAR, CARDIOPULMONARY, GENITOURINARY, SEXUAL DYSFUNCTION, ONCOLOGICAL, HEPATOLOGICAL, OPHTHALMIC, RESPIRATORY, NEUROLOGICAL, GASTROINTESTINAL, HORMONAL, DERMATOLOGICAL, PSYCHIATRIC AND IMMUNE SYSTEM RELATED DISEASES AND DISORDERS; VACCINES (U.S. CLS. 6, 18, 44, 46, 51 AND 52).

BARBARA GAYNOR, EXAMINING ATTORNEY

**CLASS 5—(Continued).**

SN 85-182,439. GLAXO GROUP LIMITED, GREENFORD, MIDDLESEX, UNITED KINGDOM, FILED 11-22-2010.

# LERONET

THE MARK CONSISTS OF STANDARD CHARACTERS WITHOUT CLAIM TO ANY PARTICULAR FONT, STYLE, SIZE, OR COLOR.

FOR PHARMACEUTICAL PREPARATIONS AND SUBSTANCES FOR THE TREATMENT OF DAMAGED SKIN AND TISSUE; PHARMACEUTICAL PREPARATIONS AND SUBSTANCES FOR THE TREATMENT OF INFECTIOUS DISEASES, BLOOD DISORDERS, PAIN, INFLAMMATION, SEPSIS, ALOPECIA, OBESITY AND COGNITIVE DISORDERS; PHARMACEUTICAL PREPARATIONS AND SUBSTANCES FOR THE TREATMENT OF VIRAL, METABOLIC, ENDOCRINE, MUSCULOSKELETAL, CARDIOVASCULAR, CARDIOPULMONARY, GENITOURINARY, SEXUAL DYSFUNCTION, ONCOLOGICAL, HEPATOLOGICAL, OPHTHALMIC, RESPIRATORY, NEUROLOGICAL, GASTROINTESTINAL, HORMONAL, DERMATOLOGICAL, PSYCHIATRIC AND IMMUNE SYSTEM RELATED DISEASES AND DISORDERS; VACCINES (U.S. CLS. 6, 18, 44, 46, 51 AND 52).

BARBARA GAYNOR, EXAMINING ATTORNEY

SN 85-182,912. KB MEDIA GROUP, LLC, SAN FRANCISCO, CA. FILED 11-22-2010.

# LAID OUT

THE MARK CONSISTS OF STANDARD CHARACTERS WITHOUT CLAIM TO ANY PARTICULAR FONT, STYLE, SIZE, OR COLOR.

FOR NUTRACEUTICALS FOR USE AS A DIETARY SUPPLEMENT; NUTRITIONAL SUPPLEMENTS (U.S. CLS. 6, 18, 44, 46, 51 AND 52).

ANGELA DUONG, EXAMINING ATTORNEY

SN 85-183,597. WESTERN HOLDINGS, LLC, CARSON CITY, NV. FILED 11-23-2010.

# BETAZINE

THE MARK CONSISTS OF STANDARD CHARACTERS WITHOUT CLAIM TO ANY PARTICULAR FONT, STYLE, SIZE, OR COLOR.

OWNER OF U.S. REG. NO. 2,846,588.  
FOR DIETARY SUPPLEMENTS (U.S. CLS. 6, 18, 44, 46, 51 AND 52).

TASNEEM HUSSAIN, EXAMINING ATTORNEY

**CLASS 5—(Continued).**

SN 85-183,938. ISTA PHARMACEUTICALS, INC., IRVINE, CA. FILED 11-23-2010.

# T-PRED

THE MARK CONSISTS OF STANDARD CHARACTERS WITHOUT CLAIM TO ANY PARTICULAR FONT, STYLE, SIZE, OR COLOR.

FOR PHARMACEUTICAL PREPARATIONS FOR THE TREATMENT OF OPHTHALMIC DISEASES AND CONDITIONS (U.S. CLS. 6, 18, 44, 46, 51 AND 52).

DOMINICK J. SALEMI, EXAMINING ATTORNEY

SN 85-184,433. MEDTECH PRODUCTS INC., IRVINGTON, NY. FILED 11-24-2010.

# LITTLE TUMMYS

THE MARK CONSISTS OF STANDARD CHARACTERS WITHOUT CLAIM TO ANY PARTICULAR FONT, STYLE, SIZE, OR COLOR.

OWNER OF U.S. REG. NO. 1,839,839.  
FOR DIETARY AND NUTRITIONAL SUPPLEMENTS FOR CHILDREN (U.S. CLS. 6, 18, 44, 46, 51 AND 52).  
FIRST USE 12-9-2009; IN COMMERCE 12-9-2009.

WILLIAM P. SHANAHAN, EXAMINING ATTORNEY

SN 85-184,478. MEDTECH PRODUCTS INC., IRVINGTON, NY. FILED 11-24-2010.

# WE MAKE IT ALL BETTER!

THE MARK CONSISTS OF STANDARD CHARACTERS WITHOUT CLAIM TO ANY PARTICULAR FONT, STYLE, SIZE, OR COLOR.

OWNER OF U.S. REG. NOS. 2,523,530, 3,570,730 AND 3,599,958.  
FOR DIETARY AND NUTRITIONAL SUPPLEMENTS FOR CHILDREN (U.S. CLS. 6, 18, 44, 46, 51 AND 52).

FIRST USE 12-9-2009; IN COMMERCE 12-9-2009.

WILLIAM P. SHANAHAN, EXAMINING ATTORNEY



**CLASS 5—(Continued).**

SN 85-184,599. MEDTECH PRODUCTS INC., IRVINGTON, NY. FILED 11-24-2010.



OWNER OF U.S. REG. NOS. 3,599,956, 3,603,585 AND 3,628,682.  
THE MARK CONSISTS OF A BOY STANDING WITH ARMS CROSSED WEARING A BALLCAP BACKWARDS.  
FOR DIETARY AND NUTRITIONAL SUPPLEMENTS FOR CHILDREN (U.S. CLS. 6, 18, 44, 46, 51 AND 52).  
FIRST USE 12-9-2009; IN COMMERCE 12-9-2009.  
WILLIAM P. SHANAHAN, EXAMINING ATTORNEY

SN 85-189,559. SYLMARK HOLDINGS LIMITED, WAN-CHAI, HONG KONG, FILED 12-2-2010.

# SENSATROL

THE MARK CONSISTS OF STANDARD CHARACTERS WITHOUT CLAIM TO ANY PARTICULAR FONT, STYLE, SIZE, OR COLOR.  
FOR TOPICAL PREPARATIONS, NAMELY SPRAYS, FOR DELAYING MALE ORGASM (U.S. CLS. 6, 18, 44, 46, 51 AND 52).  
TRACY CROSS, EXAMINING ATTORNEY

SN 85-194,200. TAMBRANDS, INC., CINCINNATI, OH. FILED 12-9-2010.

# PURSE AND POCKET

THE MARK CONSISTS OF STANDARD CHARACTERS WITHOUT CLAIM TO ANY PARTICULAR FONT, STYLE, SIZE, OR COLOR.  
FOR TAMPONS (U.S. CLS. 6, 18, 44, 46, 51 AND 52).  
FIRST USE 2-14-2010; IN COMMERCE 2-14-2010.  
JENNIFER MARTIN, EXAMINING ATTORNEY

**CLASS 5—(Continued).**

SN 85-194,214. TAMBRANDS, INC., CINCINNATI, OH. FILED 12-9-2010.

# KEEP-IT-SECRET

THE MARK CONSISTS OF STANDARD CHARACTERS WITHOUT CLAIM TO ANY PARTICULAR FONT, STYLE, SIZE, OR COLOR.  
FOR TAMPONS (U.S. CLS. 6, 18, 44, 46, 51 AND 52).  
FIRST USE 2-14-2010; IN COMMERCE 2-14-2010.  
JENNIFER MARTIN, EXAMINING ATTORNEY

SN 85-194,366. SMITH & NEPHEW, INC., MEMPHIS, TN. FILED 12-9-2010.

# JFT

THE MARK CONSISTS OF STANDARD CHARACTERS WITHOUT CLAIM TO ANY PARTICULAR FONT, STYLE, SIZE, OR COLOR.  
FOR INJECTABLE SODIUM HYALURONATE SOLUTION FOR THE TREATMENT OF BONE AND JOINT PAIN (U.S. CLS. 6, 18, 44, 46, 51 AND 52).  
ARETHA SOMERVILLE, EXAMINING ATTORNEY

SN 85-196,954. KB MEDIA GROUP, LLC, SAN FRANCISCO, CA. FILED 12-13-2010.

# FRIENERGY

THE MARK CONSISTS OF STANDARD CHARACTERS WITHOUT CLAIM TO ANY PARTICULAR FONT, STYLE, SIZE, OR COLOR.  
FOR NUTRACEUTICALS FOR USE AS A DIETARY SUPPLEMENT; NUTRITIONAL SUPPLEMENTS (U.S. CLS. 6, 18, 44, 46, 51 AND 52).  
ANGELA DUONG, EXAMINING ATTORNEY

**CLASS 5—(Continued).**

SN 85-200,657. GLAXOSMITHKLINE LLC, WILMINGTON, DE. FILED 12-17-2010.

# LP3

THE MARK CONSISTS OF STANDARD CHARACTERS WITHOUT CLAIM TO ANY PARTICULAR FONT, STYLE, SIZE, OR COLOR.

FOR MEDICATED MOUTH SPRAY (U.S. CLS. 6, 18, 44, 46, 51 AND 52).

TASNEEM HUSSAIN, EXAMINING ATTORNEY

**CLASS 5—(Continued).**

SN 85-213,924. MARZ, KEITH, VAN NUYS, CA. FILED 1-10-2011.

# 428 HANITIZER

THE MARK CONSISTS OF STANDARD CHARACTERS WITHOUT CLAIM TO ANY PARTICULAR FONT, STYLE, SIZE, OR COLOR.

FOR HAND-SANITIZING PREPARATIONS; SPRAY SANITIZER FOR PERSONAL USE (U.S. CLS. 6, 18, 44, 46, 51 AND 52).

KAREN SEVERSON, EXAMINING ATTORNEY

SN 85-204,107. MEDTECH PRODUCTS INC., IRVINGTON, NY. FILED 12-22-2010.

# NEW-SKIN

THE MARK CONSISTS OF STANDARD CHARACTERS WITHOUT CLAIM TO ANY PARTICULAR FONT, STYLE, SIZE, OR COLOR.

OWNER OF U.S. REG. NO. 1,757,962.  
FOR TOPICAL GEL FOR THE TREATMENT OF SCARS (U.S. CLS. 6, 18, 44, 46, 51 AND 52).  
FIRST USE 6-2-2009; IN COMMERCE 6-2-2009.  
WILLIAM P. SHANAHAN, EXAMINING ATTORNEY

SN 85-218,033. MEDTECH PRODUCTS INC., IRVINGTON, NY. FILED 1-14-2011.

# CURE FOR THE REDEYE FLIGHT

THE MARK CONSISTS OF STANDARD CHARACTERS WITHOUT CLAIM TO ANY PARTICULAR FONT, STYLE, SIZE, OR COLOR.

FOR OPHTHALMIC PREPARATION, NAMELY, EYE DROPS (U.S. CLS. 6, 18, 44, 46, 51 AND 52).

WILLIAM P. SHANAHAN, EXAMINING ATTORNEY

SN 85-213,170. BONDIA LABS, INC., TIBURON, CA. FILED 1-7-2011.

# HeartBoost

THE MARK CONSISTS OF STANDARD CHARACTERS WITHOUT CLAIM TO ANY PARTICULAR FONT, STYLE, SIZE, OR COLOR.

FOR DIETARY AND NUTRITIONAL SUPPLEMENTS (U.S. CLS. 6, 18, 44, 46, 51 AND 52).

CAROLYN CATALDO, EXAMINING ATTORNEY

SN 85-218,052. MEDTECH PRODUCTS INC., IRVINGTON, NY. FILED 1-14-2011.

# REDEYE FLIGHT

THE MARK CONSISTS OF STANDARD CHARACTERS WITHOUT CLAIM TO ANY PARTICULAR FONT, STYLE, SIZE, OR COLOR.

FOR OPHTHALMIC PREPARATION, NAMELY, EYE DROPS (U.S. CLS. 6, 18, 44, 46, 51 AND 52).

WILLIAM P. SHANAHAN, EXAMINING ATTORNEY

**CLASS 5—(Continued).**

SN 85-221,229. NOVARTIS AG, BASEL, SWITZERLAND, FILED 1-19-2011.

**BESERO**

THE MARK CONSISTS OF STANDARD CHARACTERS WITHOUT CLAIM TO ANY PARTICULAR FONT, STYLE, SIZE, OR COLOR.

PRIORITY CLAIMED UNDER SEC. 44(D) ON SWITZERLAND APPLICATION NO. 64265/2010, FILED 12-30-2010, REG. NO. 610065, DATED 1-7-2011, EXPIRES 12-30-2020.

OWNER OF U.S. REG. NO. 3,821,791.  
FOR VACCINES FOR HUMAN USE (U.S. CLS. 6, 18, 44, 46, 51 AND 52).  
JOHN HWANG, EXAMINING ATTORNEY

**CLASS 5—(Continued).**

SN 85-221,472. NOVARTIS AG, BASEL, SWITZERLAND, FILED 1-19-2011.

**BEXSIRO**

THE MARK CONSISTS OF STANDARD CHARACTERS WITHOUT CLAIM TO ANY PARTICULAR FONT, STYLE, SIZE, OR COLOR.

PRIORITY CLAIMED UNDER SEC. 44(D) ON SWITZERLAND APPLICATION NO. 64266/2010, FILED 12-30-2010, REG. NO. 610066, DATED 1-7-2011, EXPIRES 12-30-2020.

OWNER OF U.S. REG. NO. 3,821,791.  
FOR VACCINES FOR HUMAN USE (U.S. CLS. 6, 18, 44, 46, 51 AND 52).  
JOHN HWANG, EXAMINING ATTORNEY

SN 85-221,354. NOVARTIS AG, BASEL, SWITZERLAND, FILED 1-19-2011.

**BEXSERA**

THE MARK CONSISTS OF STANDARD CHARACTERS WITHOUT CLAIM TO ANY PARTICULAR FONT, STYLE, SIZE, OR COLOR.

PRIORITY CLAIMED UNDER SEC. 44(D) ON SWITZERLAND APPLICATION NO. 64269/2010, FILED 12-30-2010, REG. NO. 610069, DATED 1-7-2011, EXPIRES 12-30-2020.

OWNER OF U.S. REG. NO. 3,821,791.  
FOR VACCINES FOR HUMAN USE (U.S. CLS. 6, 18, 44, 46, 51 AND 52).  
JOHN HWANG, EXAMINING ATTORNEY

SN 85-221,499. NOVARTIS AG, BASEL, SWITZERLAND, FILED 1-19-2011.

**BEXCERO**

THE MARK CONSISTS OF STANDARD CHARACTERS WITHOUT CLAIM TO ANY PARTICULAR FONT, STYLE, SIZE, OR COLOR.

PRIORITY CLAIMED UNDER SEC. 44(D) ON SWITZERLAND APPLICATION NO. 64268/2010, FILED 12-30-2010, REG. NO. 610068, DATED 1-7-2011, EXPIRES 12-30-2020.

OWNER OF U.S. REG. NO. 3,821,791.  
FOR VACCINES FOR HUMAN USE (U.S. CLS. 6, 18, 44, 46, 51 AND 52).  
JOHN HWANG, EXAMINING ATTORNEY

SN 85-221,387. NOVARTIS AG, BASEL, SWITZERLAND, FILED 1-19-2011.

**BESIRO**

THE MARK CONSISTS OF STANDARD CHARACTERS WITHOUT CLAIM TO ANY PARTICULAR FONT, STYLE, SIZE, OR COLOR.

PRIORITY CLAIMED UNDER SEC. 44(D) ON SWITZERLAND APPLICATION NO. 64267/2010, FILED 12-30-2010, REG. NO. 610067, DATED 1-7-2011, EXPIRES 12-30-2020.

OWNER OF U.S. REG. NO. 3,821,791.  
FOR VACCINES FOR HUMAN USE (U.S. CLS. 6, 18, 44, 46, 51 AND 52).  
JOHN HWANG, EXAMINING ATTORNEY

SN 85-221,519. NOVARTIS AG, BASEL, SWITZERLAND, FILED 1-19-2011.

**BEXERO**

THE MARK CONSISTS OF STANDARD CHARACTERS WITHOUT CLAIM TO ANY PARTICULAR FONT, STYLE, SIZE, OR COLOR.

PRIORITY CLAIMED UNDER SEC. 44(D) ON SWITZERLAND APPLICATION NO. 64270/2010, FILED 12-30-2010, REG. NO. 610070, DATED 1-7-2011, EXPIRES 12-30-2020.

OWNER OF U.S. REG. NO. 3,821,791.  
FOR VACCINES FOR HUMAN USE (U.S. CLS. 6, 18, 44, 46, 51 AND 52).  
JOHN HWANG, EXAMINING ATTORNEY

**CLASS 5—(Continued).**

SN 85-231,429. SUNKIST GROWERS, INC., SHERMAN OAKS, CA. FILED 2-1-2011.

# SUNKIST

THE MARK CONSISTS OF STANDARD CHARACTERS WITHOUT CLAIM TO ANY PARTICULAR FONT, STYLE, SIZE, OR COLOR.

OWNER OF U.S. REG. NOS. 72,087, 726,900 AND OTHERS. FOR NUTRITIONAL SUPPLEMENTS; VITAMINS (U.S. CLS. 6, 18, 44, 46, 51 AND 52). FIRST USE 11-30-2005; IN COMMERCE 11-30-2005. REBECCA POVARCHUK, EXAMINING ATTORNEY

SN 85-235,262. BIOASIA LTD., BANGKOK, THAILAND, FILED 2-7-2011.

# FOREST RAIN

THE MARK CONSISTS OF STANDARD CHARACTERS WITHOUT CLAIM TO ANY PARTICULAR FONT, STYLE, SIZE, OR COLOR.

FOR AROMATIZED BEVERAGES BASED ON FRUIT, PROTEIN, CORDIAL, SUGAR AND OTHER FLUID NUTRIENTS, NAMELY, MEAL REPLACEMENT DRINKS FOR USE AS A FOOD FILLERS; DIETARY SUPPLEMENTAL DRINKS; DIETARY SUPPLEMENTAL DRINKS IN THE NATURE OF VITAMIN AND MINERAL BEVERAGES; HERBAL DRINKS USED TO AID IN SLEEP AND RELAXATION; NUTRITIONAL DRINK MIX FOR USE AS A MEAL REPLACEMENT; NUTRITIONALLY FORTIFIED WATER; POWDERED FRUIT-FLAVORED DIETARY SUPPLEMENT DRINK MIX; POWDERED NUTRITIONAL SUPPLEMENT DRINK MIX; VITAMIN ENRICHED WATER (U.S. CLS. 6, 18, 44, 46, 51 AND 52).

MATTHEW MCDOWELL, EXAMINING ATTORNEY

**CLASS 6—METAL GOODS**

SN 77-561,155. ROVANCO PIPING SYSTEMS INC., JOLIET, IL. FILED 9-3-2008.

# RHINOCOAT

THE MARK CONSISTS OF STANDARD CHARACTERS WITHOUT CLAIM TO ANY PARTICULAR FONT, STYLE, SIZE, OR COLOR.

FOR METAL PIPES FOR LIQUID AND GAS TRANSFER (U.S. CLS. 2, 12, 13, 14, 23, 25 AND 50). FIRST USE 12-31-1998; IN COMMERCE 12-31-1998. STEVEN PEREZ, EXAMINING ATTORNEY

**CLASS 6—(Continued).**

SN 77-826,844. DELLACECCA, DEAN, CARY, IL. FILED 9-15-2009.



OWNER OF U.S. REG. NO. 3,547,879. THE MARK CONSISTS OF A STYLIZED FORM OF THE WORD "DURA".

FOR METAL PIPING SYSTEM ELEMENTS, NAMELY, FLEXIBLE CONNECTORS AND BELLOWS ASSEMBLIES FOR PIPING IN VACUUM SYSTEMS, HIGH PRESSURE SYSTEMS, SAFETY SYSTEMS, AIRCRAFT SYSTEMS AND MEDICAL SYSTEMS; METAL EXPANSION JOINTS AND EXPANSION PIPE LOOPS, ALL FOR PIPING AND DUCTING; METAL EXHAUST FLEXIBLE CONNECTORS FOR EXHAUST MANIFOLDS AND EXHAUST ASSEMBLIES; METAL PIPE CONNECTORS; METAL PIPE SUPPORTS; METAL PIPE GUIDES; METAL FLEXIBLE DUCTING; INDUSTRIAL METAL HOSES; METAL FLEXIBLE INDUSTRIAL HOSES; METAL EXPANSION PIPE LOOPS (U.S. CLS. 2, 12, 13, 14, 23, 25 AND 50).

SANJEEV VOHRA, EXAMINING ATTORNEY

SN 77-826,890. DELLACECCA, DEAN, CARY, IL. FILED 9-15-2009.



OWNER OF U.S. REG. NO. 3,547,879. THE MARK CONSISTS OF A STYLIZED FORM OF THE WORD "DURAFLEX".

FOR METAL PIPING SYSTEM ELEMENTS, NAMELY, FLEXIBLE CONNECTORS AND BELLOWS ASSEMBLIES FOR PIPING IN VACUUM SYSTEMS, HIGH PRESSURE SYSTEMS, SAFETY SYSTEMS, AIRCRAFT SYSTEMS AND MEDICAL SYSTEMS; METAL EXPANSION JOINTS AND EXPANSION PIPE LOOPS, ALL FOR PIPING AND DUCTING; METAL EXHAUST FLEXIBLE CONNECTORS FOR EXHAUST MANIFOLDS AND EXHAUST ASSEMBLIES; METAL PIPE CONNECTORS; METAL PIPE SUPPORTS; METAL PIPE GUIDES; METAL FLEXIBLE DUCTING; INDUSTRIAL METAL HOSES; METAL FLEXIBLE INDUSTRIAL HOSES; METAL EXPANSION PIPE LOOPS (U.S. CLS. 2, 12, 13, 14, 23, 25 AND 50).

SANJEEV VOHRA, EXAMINING ATTORNEY

**CLASS 6—(Continued).**

SN 77-838,916. CONTAINMENT SOLUTIONS, INC., CON-ROE, TX. FILED 10-1-2009.

# GENCUBE

THE MARK CONSISTS OF STANDARD CHARACTERS WITHOUT CLAIM TO ANY PARTICULAR FONT, STYLE, SIZE, OR COLOR.

FOR METAL FLUID STORAGE TANKS, NAMELY, FUEL STORAGE TANKS (U.S. CLS. 2, 12, 13, 14, 23, 25 AND 50).

SKYE YOUNG, EXAMINING ATTORNEY

**CLASS 6—(Continued).**

SN 79-090,716. FEMCO HOLDING B.V., SK MIJDRECHT, NETHERLANDS, FILED 7-16-2010.



PRIORITY DATE OF 2-3-2010 IS CLAIMED. OWNER OF INTERNATIONAL REGISTRATION 1060374 DATED 7-16-2010, EXPIRES 7-16-2020.

THE STIPPLING IS A FEATURE OF THE MARK AND DOES NOT INDICATE COLOR.

THE MARK CONSISTS OF A HIGHLY STYLIZED ANTHROPOMORPHIC BOLT WITH FACIAL FEATURES AND WEARING GLOVES, OVERALLS, AND A HAT, WITH A WRENCH IN ITS OVERALLS POCKET.

FOR BOLTS, NUTS AND PLUGS OF METAL; LIQUID DRAIN PLUGS OF METAL AND GOODS OF METAL FOR DRAINING LIQUIDS, NAMELY, METAL DRAIN PIPES; TUBES OF METAL (U.S. CLS. 2, 12, 13, 14, 23, 25 AND 50).

ADA HAN, EXAMINING ATTORNEY

SN 77-841,958. JOSAM COMPANY, PHILADELPHIA, PA. FILED 10-5-2009.



NO CLAIM IS MADE TO THE EXCLUSIVE RIGHT TO USE "COMPLETE DRAINAGE SYSTEM", "STAINLESS STEEL", OR "PUSH FIT", APART FROM THE MARK AS SHOWN.

THE MARK CONSISTS OF A STYLIZED LOGO DEPICTING TWO ROUND PIPES FACING EACH OTHER AND SPACED APART WITH AN ARROW IN THE MIDDLE, AND THE WORDS "PUSH" AND "FIT" ARE SUPERIMPOSED ON THE TWO PIPES, WITH PARTIAL CIRCLES ABOVE AND BELOW THE PIPES CONTAINING THE WORDS "STAINLESS" AND "STEEL". THE WORD "COMPLETE" APPEARS ABOVE THE TOP PARTIAL CIRCLE AND THE WORDING "DRAINAGE SYSTEM" APPEARS BELOW THE LOWER PARTIAL CIRCLE.

FOR STAINLESS STEEL PLUMBING SUPPLIES, NAMELY, PIPES AND PIPE FITTINGS (U.S. CLS. 2, 12, 13, 14, 23, 25 AND 50).

VERNA BETH RIRIE, EXAMINING ATTORNEY

SN 79-091,781. AVALON NORWAY AS, NORWAY, FILED 11-15-2010.

# iSub

THE MARK CONSISTS OF STANDARD CHARACTERS WITHOUT CLAIM TO ANY PARTICULAR FONT, STYLE, SIZE, OR COLOR.

PRIORITY DATE OF 5-27-2010 IS CLAIMED. OWNER OF INTERNATIONAL REGISTRATION 1062968 DATED 11-15-2010, EXPIRES 11-15-2020.

FOR LIFTING SUBS OF METAL (U.S. CLS. 2, 12, 13, 14, 23, 25 AND 50).

DAVID TOOLEY, EXAMINING ATTORNEY

**CLASS 6—(Continued).**

SN 85-003,964. EASYLINK INDUSTRIAL CO., LTD., KAOHSIUNG, TAIWAN, FILED 4-1-2010.

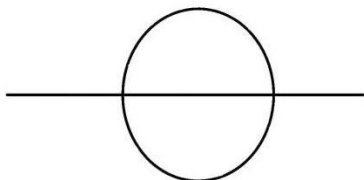

THE MARK CONSISTS OF A DESIGN IN THE FORM OF A CIRCLE DIVIDED INTO HALVES BY A HORIZONTAL LINE.

FOR METAL FASTENERS, NAMELY, SCREWS, BOLTS, NUTS, NAILS; METAL HARDWARE, NAMELY, WASHERS; METAL SCREWS; SCREWS OF METAL (U.S. CLS. 2, 12, 13, 14, 23, 25 AND 50).

KIMBERLY PERRY, EXAMINING ATTORNEY

SN 85-006,906. SUMMIT ENTERTAINMENT, LLC, SANTA MONICA, CA. FILED 4-6-2010.



THE MARK CONSISTS OF A CIRCULAR TRIBAL TATTOO DESIGN DEPICTING TWO WOLVES FACING ONE ANOTHER IN A HOWLING POSITION, SET AMONGST NUMEROUS INTERWOVEN LINES AND SHAPES AND ALL WITHIN THE CIRCLE.

FOR METAL KEY CHAINS AND METAL BAG CLIPS; METAL SIGNS AND METAL DOOR KNOCKERS (U.S. CLS. 2, 12, 13, 14, 23, 25 AND 50).

FIRST USE 11-0-2009; IN COMMERCE 11-0-2009.

TRACY FLETCHER, EXAMINING ATTORNEY

**CLASS 6—(Continued).**

SN 85-014,743. BETTER METAL, LLC, LA VERGNE, TN. FILED 4-15-2010.

**BETTER-WELD**

THE MARK CONSISTS OF STANDARD CHARACTERS WITHOUT CLAIM TO ANY PARTICULAR FONT, STYLE, SIZE, OR COLOR.

FOR EXOTHERMIC WELDING APPARATUS COMPRISED PRIMARILY OF WELD METAL IN THE NATURE OF WELD METAL SHOTS AND WELD METAL DISCS AND ALSO COMPRISED OF FLINT IGNITORS, ELECTRONIC IGNITORS, METAL MOLD FASTENERS, NAMELY, MECHANICAL HANDLE CLAMPS TO PHYSICALLY SECURE GRAPHITE MOLDS DURING THE EXOTHERMIC WELDING PROCESS, METAL MOUNTINGS AND METAL CLAMPS, NON-METAL WELDING MOLDS, ALL SOLD AS A UNIT FOR USE IN WELDING APPLICATIONS WHICH EMPLOY EXOTHERMIC ENERGY (U.S. CLS. 2, 12, 13, 14, 23, 25 AND 50).

KATHERINE CONNOLLY, EXAMINING ATTORNEY

SN 85-024,460. ALLFAST FASTENING SYSTEMS, INC., CITY OF INDUSTRY, CA. FILED 4-27-2010.

**ALL-MATIC**

THE MARK CONSISTS OF STANDARD CHARACTERS WITHOUT CLAIM TO ANY PARTICULAR FONT, STYLE, SIZE, OR COLOR.

FOR METAL BLIND BOLTS (U.S. CLS. 2, 12, 13, 14, 23, 25 AND 50).

FIRST USE 4-0-2010; IN COMMERCE 4-0-2010.

LINDA ORNDORFF, EXAMINING ATTORNEY

SN 85-027,953. BEN L. SCHMID, BALBOA ISLAND, CA. FILED 4-30-2010.

**MAXI-SYSTEM**

THE MARK CONSISTS OF STANDARD CHARACTERS WITHOUT CLAIM TO ANY PARTICULAR FONT, STYLE, SIZE, OR COLOR.

FOR WOOD FRAMING CONSTRUCTION SYSTEM ALL SOLD AS A UNIT COMPRISED OF METAL SCREWS, METAL BOLTS, METAL NAILS, WALLBOARD TAPE JOINT COMPOUNDS, BINDERS IN THE NATURE OF LATEX ADHESIVES, SHEAR LUGS IN THE NATURE OF STEEL AND OTHER METALLIC MATERIAL, AND PRINTED INSTRUCTION SHEETS SOLD THEREWITH FOR PROVIDING MAXIMUM RESISTANCE TO EARTHQUAKES, WIND AND OTHER FORCES OF NATURE (U.S. CLS. 2, 12, 13, 14, 23, 25 AND 50).

REBECCA SMITH, EXAMINING ATTORNEY

**CLASS 6—(Continued).**

SN 85-045,115. GLOBE SPECIALTY METALS, INC., NEW YORK, NY. FILED 5-21-2010.



NO CLAIM IS MADE TO THE EXCLUSIVE RIGHT TO USE "SPECIALTY METALS", APART FROM THE MARK AS SHOWN.

THE COLOR(S) BLUE AND GREY IS/ARE CLAIMED AS A FEATURE OF THE MARK.

THE MARK CONSISTS OF THE WORDS "GLOBE SPECIALTY METALS" IN BLUE WITH THE LETTER "O" IN "GLOBE" REPLACED BY A DRAWING OF A GLOBE IN GREY SHOWING ONLY PARALLELS AND MERIDIANS.

FOR METALS AND METAL ALLOYS, NAMELY, FERRO-ALLOYS, SILICON METAL; AND METALS AND METAL ALLOYS FOR USE IN THE FUTURE MANUFACTURE OF FINISHED GOODS (U.S. CLS. 2, 12, 13, 14, 23, 25 AND 50).

FIRST USE 0-0-2007; IN COMMERCE 0-0-2007.  
BENJAMIN OKEKE, EXAMINING ATTORNEY

**CLASS 6—(Continued).**

SN 85-045,775. RAV BARIACH (08) INDUSTRIES LTD., ASHKELON, ISRAEL, FILED 5-23-2010.



THE COLOR(S) BROWN AND LIGHT BROWN IS/ARE CLAIMED AS A FEATURE OF THE MARK.

THE MARK CONSISTS OF A MAN ON SHIELD IN COLORS BROWN AND LIGHT BROWN.

FOR DOORS OF METAL (U.S. CLS. 2, 12, 13, 14, 23, 25 AND 50).

ZACHARY BELLO, EXAMINING ATTORNEY

SN 85-049,072. HOUSTON ART GLASS ENTERPRISES, INC., HOUSTON, TX. FILED 5-27-2010.

# Barcelona

THE MARK CONSISTS OF STANDARD CHARACTERS WITHOUT CLAIM TO ANY PARTICULAR FONT, STYLE, SIZE, OR COLOR.

FOR WROUGHT IRON DECORATIVE ARTWORK (U.S. CLS. 2, 12, 13, 14, 23, 25 AND 50).

FIRST USE 10-1-2004; IN COMMERCE 10-1-2004.  
CHARLES L. JENKINS, EXAMINING ATTORNEY

SN 85-045,519. RADTKE, EDWARD A, EL CAJON, CA. FILED 5-21-2010.

# StowAway

THE MARK CONSISTS OF STANDARD CHARACTERS WITHOUT CLAIM TO ANY PARTICULAR FONT, STYLE, SIZE, OR COLOR.

FOR SPRING-RETRACTED METAL HOSE REELS (U.S. CLS. 2, 12, 13, 14, 23, 25 AND 50).

FIRST USE 5-11-2010; IN COMMERCE 5-11-2010.  
JACLYN KIDWELL WALKER, EXAMINING ATTORNEY

SN 85-049,133. HOUSTON ART GLASS ENTERPRISES, INC., HOUSTON, TX. FILED 5-27-2010.

# Orvietto

THE MARK CONSISTS OF STANDARD CHARACTERS WITHOUT CLAIM TO ANY PARTICULAR FONT, STYLE, SIZE, OR COLOR.

FOR WROUGHT IRON DECORATIVE ARTWORK (U.S. CLS. 2, 12, 13, 14, 23, 25 AND 50).

FIRST USE 10-1-2004; IN COMMERCE 10-1-2004.  
CHARLES L. JENKINS, EXAMINING ATTORNEY

**CLASS 6—(Continued).**

SN 85-063,155. VITA MANUFACTURING CO., LTD.,  
CHANG HUA, TAIWAN, FILED 6-15-2010.



OWNER OF U.S. REG. NO. 2,600,201.  
THE COLOR(S) WHITE, BLACK AND GRAY IS/ARE  
CLAIMED AS A FEATURE OF THE MARK.

THE MARK CONSISTS OF A THREE-SIDED TRIANGU-  
LAR FIGURE SHADED WITH WHITE, BLACK AND GRAY  
TO APPEAR THREE-DIMENSIONAL WITH THE WORD  
"VITA" APPEARING IN THE COLOR GRAY DIRECTLY  
BELOW IT.

FOR BOLTS OF METAL; DOOR CASINGS OF METAL;  
DOOR FITTINGS OF METAL; DOOR FRAMES OF  
METAL; DOOR JAMBS OF METAL; DOOR PANELS OF  
METAL; DOOR STOPS OF METAL; LETTER BOXES OF  
METAL; METAL DOOR BOLTS; METAL DOOR  
LATCHES; METAL DOORKNOCKERS; METAL HAN-  
DLES FOR DOORS; METAL HINGES; METAL KNOBS;  
METAL LATCH BARS; METAL LATCHES; METAL  
SLIDES FOR DOORS AND WINDOWS; METAL WIN-  
DOW FRAMES; METAL WINDOW SILLS (U.S. CLS. 2, 12,  
13, 14, 23, 25 AND 50).

GENE MACIOL, EXAMINING ATTORNEY

**CLASS 6—(Continued).**

SN 85-113,088. SMITH, DANIEL, R., VENICE, CA. FILED 8-  
22-2010.



NO CLAIM IS MADE TO THE EXCLUSIVE RIGHT TO  
USE "SCREW" AND "UNIVERSAL UTILITY SCREW",  
APART FROM THE MARK AS SHOWN.

THE COLOR(S) BLUE AND WHITE IS/ARE CLAIMED AS  
A FEATURE OF THE MARK.

THE MARK CONSISTS OF A BLUE CIRCLE ON A WHITE  
BACKGROUND WITH THE LETTERS "UU" IN BLUE IN  
THE CENTER OF THE CIRCLE ABOVE THE WORD  
"SCREW" ALSO IN BLUE. BENEATH THE WORD "SCREW"  
IS THE WORDING "UNIVERSAL UTILITY SCREW" IN  
BLUE.

FOR METAL SCREWS (U.S. CLS. 2, 12, 13, 14, 23, 25  
AND 50).

KATINA MISTER, EXAMINING ATTORNEY

SN 85-094,541. ECOLAB USA INC., SAINT PAUL, MN. FILED  
7-28-2010.

# ECOLAB

THE MARK CONSISTS OF STANDARD CHARACTERS  
WITHOUT CLAIM TO ANY PARTICULAR FONT, STYLE,  
SIZE, OR COLOR.

OWNER OF U.S. REG. NOS. 1,497,423, 1,538,458 AND  
OTHERS.

FOR METAL HOOKS; METAL HOSE REEL; METAL  
LADDERS; METAL PRE-RINSE, WASH DOWN SPRAY  
NOZZLES FOR COMMERCIAL AND INDUSTRIAL USE;  
TOWEL DISPENSERS OF METAL; METAL MOP HAN-  
DLES (U.S. CLS. 2, 12, 13, 14, 23, 25 AND 50).

FIRST USE 10-26-1997; IN COMMERCE 10-26-1997.

BRENDAN REGAN, EXAMINING ATTORNEY

SN 85-122,530. AMERICAN FASTENING SYSTEMS, MAPLE-  
WOOD, MN. FILED 9-3-2010.

# STRUCTURE-LOC

THE MARK CONSISTS OF STANDARD CHARACTERS  
WITHOUT CLAIM TO ANY PARTICULAR FONT, STYLE,  
SIZE, OR COLOR.

FOR METAL FASTENERS, NAMELY, SCREWS; ME-  
TAL SCREWS (U.S. CLS. 2, 12, 13, 14, 23, 25 AND 50).

FIRST USE 1-15-2009; IN COMMERCE 1-15-2009.

RAMONA ORTIGA, EXAMINING ATTORNEY



**CLASS 6—(Continued).**

SN 85-128,648. CERVANTES ALCANTAR, RAFAEL, GUADALAJARA, JALISCO, MEXICO, FILED 9-13-2010.



NO CLAIM IS MADE TO THE EXCLUSIVE RIGHT TO USE "UNIVERSAL", APART FROM THE MARK AS SHOWN.

THE MARK CONSISTS OF THE LETTER "Q" AND A GLOBE WITH OUTLINES OF THE CONTINENTS INSIDE THE "Q". THE WORDING "PISA UNIVERSAL" APPEARS TO THE RIGHT OF THE LETTER "Q" AND GLOBE. THE TERM "UNIVERSAL" IS UNDERLINED.

FOR DRAIN PIPES MADE OF METAL; METAL DRAIN PIPES; METAL DRAINS FOR USE IN CONSTRUCTION OF BASEMENT WATERPROOFING SYSTEMS; METAL VENT COVERS FOR ROOF DECK PROTRUSIONS, DRAINS AND PITCH PANS; METALLIC DRAIN TRAPS (U.S. CLS. 2, 12, 13, 14, 23, 25 AND 50).

FIRST USE 2-22-2007; IN COMMERCE 2-22-2007.  
CYNTHIA SLOAN, EXAMINING ATTORNEY

SN 85-133,559. GLOBAL E.D.M. SUPPLIES, INC., MASON, OH. FILED 9-20-2010.

**OPTIMA**

THE MARK CONSISTS OF STANDARD CHARACTERS WITHOUT CLAIM TO ANY PARTICULAR FONT, STYLE, SIZE, OR COLOR.

FOR WIRE FOR ELECTRICAL DISCHARGE MACHINING (U.S. CLS. 2, 12, 13, 14, 23, 25 AND 50).

FIRST USE 12-0-2009; IN COMMERCE 4-7-2010.  
JAY FLOWERS, EXAMINING ATTORNEY

SN 85-148,484. JOHN MANEELY COMPANY, BEACHWOOD, OH. FILED 10-8-2010.

**WHEATLAND**

THE MARK CONSISTS OF STANDARD CHARACTERS WITHOUT CLAIM TO ANY PARTICULAR FONT, STYLE, SIZE, OR COLOR.

FOR CONTINUOUS WELD AND ELECTRIC WELD METAL TUBING PRODUCTS; STEEL PIPE; GALVANIZED METAL MECHANICAL TUBING; METAL FENCE FRAMEWORK (U.S. CLS. 2, 12, 13, 14, 23, 25 AND 50).

FIRST USE 0-0-1877; IN COMMERCE 0-0-1877.  
MARK PILARO, EXAMINING ATTORNEY

**CLASS 6—(Continued).**

SN 85-150,601. BAILEY LUCHT ENTERPRISES, DBA AMERICAN FASTENING SYSTEMS, MAPLEWOOD, MN. FILED 10-12-2010.

**WOODPRO FASTENERS**

THE MARK CONSISTS OF STANDARD CHARACTERS WITHOUT CLAIM TO ANY PARTICULAR FONT, STYLE, SIZE, OR COLOR.

NO CLAIM IS MADE TO THE EXCLUSIVE RIGHT TO USE "FASTENERS", APART FROM THE MARK AS SHOWN.

FOR METAL FASTENERS, NAMELY, SCREWS, NAILS, HEADLESS PINS, BRADS, STAPLES FOR CONSTRUCTION OR INDUSTRIAL USE, AND NAILS IN THE NATURE OF CLEATS (U.S. CLS. 2, 12, 13, 14, 23, 25 AND 50).

FIRST USE 9-27-2010; IN COMMERCE 10-5-2010.  
VIVIAN MICZNIK FIRST, EXAMINING ATTORNEY

SN 85-154,726. CAN-AM ENGINEERED PRODUCTS, INC., LIVONIA, MI. FILED 10-18-2010.

**TURBOAIR DRYING & FINISHING SYSTEM**

THE MARK CONSISTS OF STANDARD CHARACTERS WITHOUT CLAIM TO ANY PARTICULAR FONT, STYLE, SIZE, OR COLOR.

NO CLAIM IS MADE TO THE EXCLUSIVE RIGHT TO USE "DRYING & FINISHING SYSTEM", APART FROM THE MARK AS SHOWN.

FOR PAINT SPRAY BOOTHS OF METAL AND STRUCTURAL COMPONENTS THEREFOR (U.S. CLS. 2, 12, 13, 14, 23, 25 AND 50).

KRISTIN DAHLING, EXAMINING ATTORNEY

SN 85-156,758. USG INTERIORS, INC., CHICAGO, IL. FILED 10-20-2010.

**DX3**

THE MARK CONSISTS OF STANDARD CHARACTERS WITHOUT CLAIM TO ANY PARTICULAR FONT, STYLE, SIZE, OR COLOR.

OWNER OF U.S. REG. NO. 1,168,937.  
FOR METAL SUSPENDED CEILING GRID SYSTEMS COMPRISING PANELS AND PARTS THEREFOR, NAMELY, RUNNERS, SUPPORT TEES, HANGERS, SPLINES, CLIPS, MOULDINGS, SUPPORT MEMBERS AND HANGING WIRE (U.S. CLS. 2, 12, 13, 14, 23, 25 AND 50).

ANDREA BUTLER, EXAMINING ATTORNEY

**CLASS 6—(Continued).**

SN 85-159,684. PRIMESOURCE BUILDING PRODUCTS, INC., IRVING, TX. FILED 10-23-2010.

**PRIMEGUARD MAX**

THE MARK CONSISTS OF STANDARD CHARACTERS WITHOUT CLAIM TO ANY PARTICULAR FONT, STYLE, SIZE, OR COLOR.

OWNER OF U.S. REG. NOS. 1,936,855, 2,940,702 AND OTHERS.

FOR FASTENERS, NAMELY, STAINLESS STEEL NAILS, SCREWS, COLLATED NAILS, AND COLLATED SCREWS; ALUMINUM NAILS, COLLATED ALUMINUM NAILS, COPPER NAILS, COLLATED COPPER NAILS (U.S. CLS. 2, 12, 13, 14, 23, 25 AND 50).

HANNO RITTNER, EXAMINING ATTORNEY

**CLASS 6—(Continued).**

SN 85-175,854. ATLAS ROOFING CORPORATION, MERIDIAN, MS. FILED 11-12-2010.

SN 85-165,174. HARTWICK INTERNATIONAL L.L.C., CENTENNIAL, CO. FILED 10-29-2010.

**ADverSHIELD**

THE MARK CONSISTS OF STANDARD CHARACTERS WITHOUT CLAIM TO ANY PARTICULAR FONT, STYLE, SIZE, OR COLOR.

FOR METAL SECURITY DOOR PANELS FEATURING ADVERTISEMENT SLOTS ALONG WITH INSERTABLE PLASTIC ADVERTISING SIGN BLANKS (U.S. CLS. 2, 12, 13, 14, 23, 25 AND 50).

DAVID C. REIHNER, EXAMINING ATTORNEY

THE MARK CONSISTS OF THE WORD "TECHNIFLO" IN STYLIZED PRINT, WITH "TECHNI" IN LOWER CASE, SLIGHTLY STYLIZED LETTERS FOLLOWED BY THE LARGER SHADOW-EFFECT LETTERS "FLO".

FOR STEEP SLOPE ROOF VENTILATION SYSTEM COMPRISED OF METAL EAVE VENTS AND METAL RIDGE VENTS (U.S. CLS. 2, 12, 13, 14, 23, 25 AND 50).

PAM WILLIS, EXAMINING ATTORNEY

SN 85-175,751. ATLAS ROOFING CORPORATION, MERIDIAN, MS. FILED 11-12-2010.

**TECHNIFLO**

THE MARK CONSISTS OF STANDARD CHARACTERS WITHOUT CLAIM TO ANY PARTICULAR FONT, STYLE, SIZE, OR COLOR.

FOR STEEP SLOPE ROOF VENTILATION SYSTEM COMPRISED OF METAL EAVE VENTS AND METAL RIDGE VENTS (U.S. CLS. 2, 12, 13, 14, 23, 25 AND 50).

PAM WILLIS, EXAMINING ATTORNEY

SN 85-180,321. MUNCHKIN, INC., NORTH HILLS, CA. FILED 11-18-2010.



OWNER OF U.S. REG. NO. 3,875,000.  
THE MARK CONSISTS OF THE WORD "PROTECT" WITH A SUPERSCRIPED STYLIZED SHIELD FOLLOWING THE SECOND "T".

FOR METAL SAFETY GATES FOR BABIES, CHILDREN, AND PETS (U.S. CLS. 2, 12, 13, 14, 23, 25 AND 50).  
FIRST USE 7-20-2010; IN COMMERCE 7-20-2010.

JIM RINGLE, EXAMINING ATTORNEY

**CLASS 6—(Continued).**

SN 85-201,160. AMERIMAX HOME PRODUCTS, INC., DULUTH, GA. FILED 12-17-2010.



OWNER OF U.S. REG. NOS. 3,839,108 AND 3,846,499.  
NO CLAIM IS MADE TO THE EXCLUSIVE RIGHT TO USE "GUTTER SHIELD", APART FROM THE MARK AS SHOWN.

THE MARK CONSISTS OF A KNIGHT IN ARMOR HOLDING A DIAMOND-SHAPED SHIELD BLOCKING LEAVES WITH THE WORDS "DIAMOND GUTTER SHIELD" BESIDE THE DIAMOND-SHAPED SHIELD. THE COLORS BLACK WHITE AND GRAY REPRESENT BACKGROUND, OUTLINING, SHADING AND/OR TRANSPARENT AREAS AND ARE NOT PART OF THE MARK.

FOR METAL DEBRIS GUARDS FOR GUTTERS (U.S. CLS. 2, 12, 13, 14, 23, 25 AND 50).  
KAREN BRACEY, EXAMINING ATTORNEY

**CLASS 7—MACHINERY**

SN 76-705,098. VASILANTONE, MICHAEL, LAKEWOOD, NJ. FILED 10-27-2010.

# ACUTX

THE MARK CONSISTS OF STANDARD CHARACTERS WITHOUT CLAIM TO ANY PARTICULAR FONT, STYLE, SIZE, OR COLOR.

FOR RETENTIONABLE SCREEN PRINTING FRAMES (U.S. CLS. 13, 19, 21, 23, 31, 34 AND 35).  
MARK RADEMACHER, EXAMINING ATTORNEY

SN 77-081,787. CROSSWING INC., AURORA, CANADA, FILED 1-12-2007.

# CROSSWING

THE MARK CONSISTS OF STANDARD CHARACTERS WITHOUT CLAIM TO ANY PARTICULAR FONT, STYLE, SIZE, OR COLOR.

PRIORITY CLAIMED UNDER SEC. 44(D) ON CANADA APPLICATION NO. 1310085, FILED 7-12-2006.

FOR AUTOMATED HOUSEHOLD AND HOUSEKEEPING PRODUCTS, NAMELY, DISHWASHERS, VACUUM CLEANERS AND WASHING MACHINES (U.S. CLS. 13, 19, 21, 23, 31, 34 AND 35).  
DANIEL CAPSHAW, EXAMINING ATTORNEY

SN 85-203,431. CAREFREE CASTERS CORP., AKA CF CASTERS CORP., MISSISSAUGA, ONTARIO, CANADA, FILED 12-21-2010.

# CARETHANE

THE MARK CONSISTS OF STANDARD CHARACTERS WITHOUT CLAIM TO ANY PARTICULAR FONT, STYLE, SIZE, OR COLOR.

FOR METAL CASTERS (U.S. CLS. 2, 12, 13, 14, 23, 25 AND 50).  
HELENE LIWINSKI, EXAMINING ATTORNEY

SN 77-820,669. FLOWSERVE HOLDINGS, INC., IRVING, TX. FILED 9-4-2009.

# ROVA

THE MARK CONSISTS OF STANDARD CHARACTERS WITHOUT CLAIM TO ANY PARTICULAR FONT, STYLE, SIZE, OR COLOR.

FOR VALVES BEING PARTS OF MACHINES; ROTARY VALVES BEING PARTS OF MACHINES; VALVES BEING PARTS OF MACHINES USED IN ENERGY RECOVERY EQUIPMENT, AND STRUCTURAL COMPONENTS AND STRUCTURAL PARTS THEREOF; ROTARY VALVES BEING PARTS OF MACHINES USED IN ENERGY RECOVERY EQUIPMENT, AND STRUCTURAL COMPONENTS AND STRUCTURAL PARTS THEREOF (U.S. CLS. 13, 19, 21, 23, 31, 34 AND 35).  
ADA HAN, EXAMINING ATTORNEY

**CLASS 7—(Continued).**

SN 77-841,331. MIELE, INC., PRINCETON, NJ. FILED 10-5-2009.

**MIELE NEPTUNE**

THE MARK CONSISTS OF STANDARD CHARACTERS WITHOUT CLAIM TO ANY PARTICULAR FONT, STYLE, SIZE, OR COLOR.

OWNER OF U.S. REG. NOS. 3,002,365, 3,802,472 AND OTHERS.

FOR VACUUM CLEANERS (U.S. CLS. 13, 19, 21, 23, 31, 34 AND 35).

FIRST USE 1-1-2009; IN COMMERCE 1-1-2009.  
ROBERT STRUCK, EXAMINING ATTORNEY

**CLASS 7—(Continued).**

SN 77-877,573. TRACTOR SUPPLY CO. OF TEXAS, LP, BRENTWOOD, TN. FILED 11-20-2009.

**COUNTYLINE**

THE MARK CONSISTS OF STANDARD CHARACTERS WITHOUT CLAIM TO ANY PARTICULAR FONT, STYLE, SIZE, OR COLOR.

OWNER OF U.S. REG. NO. 3,475,488.

FOR POWER-OPERATED SPRAYERS; REPLACEMENT PARTS FOR TRACTORS AND LAWN MOWERS; AND PULL-TYPE AGRICULTURAL IMPLEMENTS AND ATTACHMENTS FOR TRACTORS, LAWN MOWERS AND ATVS, NAMELY, ROTARY TILLERS, TILLAGE DISCS, CULTIVATORS, TURNING PLOWS, MIDDLE BUSTERS, SUBSOILERS, LANDSCAPE RAKES, BOX BLADES, GRADER BLADES, BOOM POLES, SCOOPS, TRAILER MOVERS, FENCE STRETCHERS AND UNROLLERS, CARRY ALLS, ROTARY CUTTERS, FINISH MOWERS, BALE SPEARS AND HAY LIFTERS (U.S. CLS. 13, 19, 21, 23, 31, 34 AND 35).

STEPHANIE ALI, EXAMINING ATTORNEY

SN 79-075,622. ZHEJIANG HAND BRAND LIFTING; MACHINERY CO., LTD., CHINA, FILED 10-7-2009.

SN 77-841,436. ATOTECH DEUTSCHLAND GMBH, BERLIN, FED REP GERMANY, FILED 10-5-2009.

**RECOTECT**

THE MARK CONSISTS OF STANDARD CHARACTERS WITHOUT CLAIM TO ANY PARTICULAR FONT, STYLE, SIZE, OR COLOR.

OWNER OF FED REP GERMANY REG. NO. 302009021161, DATED 7-2-2009, EXPIRES 4-30-2019.

FOR PLATING MACHINES FOR SURFACE TREATMENT, NAMELY, PASSIVATION AND METALLIZATION OF SURFACES; PLATING EQUIPMENT FOR METALLIZATION OF SURFACES, NAMELY, PLATING TANKS, PLATING MACHINES COMPRISING RINSE WATER TANKS, ELECTRIC PUMPS, AND MACHINES FOR COOLING SOLUTION IN PLATING TANKS, ALL SOLD AS A UNIT, FOR PASSIVATION AND METALLIZATION OF SURFACES FOR USE IN THE ELECTRONICS INDUSTRY; AND PLATING MACHINES FOR REGENERATION OF SOLUTIONS FOR SURFACE TREATMENT (U.S. CLS. 13, 19, 21, 23, 31, 34 AND 35).

PATRICIA EVANKO, EXAMINING ATTORNEY



OWNER OF INTERNATIONAL REGISTRATION 1020199 DATED 10-7-2009, EXPIRES 10-7-2019.

NO CLAIM IS MADE TO THE EXCLUSIVE RIGHT TO USE THE NON-LATIN CHARACTERS THAT TRANSLITERATE TO SHOU, APART FROM THE MARK AS SHOWN.

THE MARK CONSISTS OF A CHINESE CHARACTER AND A HAND MAKING A THUMB UP SIGN.

THE ENGLISH TRANSLATION OF THE FOREIGN WORD(S) IN THE MARK IS: THE CHINESE CHARACTER MEANS "HAND".

THE TRANSLITERATION OF THE NON-LATIN CHARACTERS IN THE MARK IS: SHOU.

FOR HOISTING AND CONVEYING MACHINERY; HAND-OPERATED ONE-TRACK CRANE; CHAIN TENSIONER, NAMELY, TRANSMISSION CHAIN TENSIONER FOR MACHINES; ROLLING DOOR HOISTING MACHINE; WINCH TONGS, NAMELY, PARTS OF CONSTRUCTION HOISTING MACHINERY FOR GRASPING OBJECTS (U.S. CLS. 13, 19, 21, 23, 31, 34 AND 35).

APRIL ROACH, EXAMINING ATTORNEY

**CLASS 7—(Continued).**

SN 79-082,090. ARKU MASCHINENBAU GMBH, FED REP GERMANY, FILED 3-12-2010.

# FlatMaster

THE MARK CONSISTS OF STANDARD CHARACTERS WITHOUT CLAIM TO ANY PARTICULAR FONT, STYLE, SIZE, OR COLOR.

OWNER OF INTERNATIONAL REGISTRATION 1037342 DATED 3-12-2010, EXPIRES 3-12-2020.

FOR MACHINES FOR METAL PROCESSING, NAMELY, LEVELERS AND PARTS THEREOF (U.S. CLS. 13, 19, 21, 23, 31, 34 AND 35).

DORITT L. CARROLL, EXAMINING ATTORNEY

SN 79-082,456. NINGBO MSEALS COMPANY LTD.; (NINGBO ANMI MIFENGJIAN YOUXIAN GONGSI), FENGHUA CITY; ZHEJIANG, CHINA, FILED 12-17-2009.

# MSEALS

OWNER OF INTERNATIONAL REGISTRATION 1038382 DATED 12-17-2009, EXPIRES 12-17-2019.

FOR MECHANICAL SEALS; CENTRIFUGAL PUMPS, GARAGE INSTALLATIONS, NAMELY, AIR PUMPS; HYDRAULIC PUMPS; PARTS OF ENGINES, NAMELY, JOINTS, NOT INCLUDING HYDRAULIC SYSTEMS FOR VEHICLE (U.S. CLS. 13, 19, 21, 23, 31, 34 AND 35).

BRIAN NEVILLE, EXAMINING ATTORNEY

SN 79-083,141. MANITOWOC CRANE GROUP FRANCE SAS, F-69130 ECULLY, FRANCE, FILED 4-28-2010.

# GreenCrane

THE MARK CONSISTS OF STANDARD CHARACTERS WITHOUT CLAIM TO ANY PARTICULAR FONT, STYLE, SIZE, OR COLOR.

PRIORITY DATE OF 3-19-2010 IS CLAIMED.

OWNER OF INTERNATIONAL REGISTRATION 1040336 DATED 4-28-2010, EXPIRES 4-28-2020.

FOR CONVEYING EQUIPMENT AND LIFTING EQUIPMENT, NAMELY, CRANES (U.S. CLS. 13, 19, 21, 23, 31, 34 AND 35).

WARREN L. OLANDRIA, EXAMINING ATTORNEY

**CLASS 7—(Continued).**

SN 79-083,142. MANITOWOC CRANE GROUP FRANCE SAS, F-69130 ECULLY, FRANCE, FILED 4-28-2010.

# BlueCrane

THE MARK CONSISTS OF STANDARD CHARACTERS WITHOUT CLAIM TO ANY PARTICULAR FONT, STYLE, SIZE, OR COLOR.

PRIORITY DATE OF 3-19-2010 IS CLAIMED.

OWNER OF INTERNATIONAL REGISTRATION 1040337 DATED 4-28-2010, EXPIRES 4-28-2020.

FOR CONVEYING EQUIPMENT AND LIFTING EQUIPMENT, NAMELY, CRANES (U.S. CLS. 13, 19, 21, 23, 31, 34 AND 35).

WARREN L. OLANDRIA, EXAMINING ATTORNEY

SN 79-085,094. RUSSELL FINEX LIMITED, UNITED KINGDOM, FILED 5-25-2010.

# RUSSELL FINEX

THE MARK CONSISTS OF STANDARD CHARACTERS WITHOUT CLAIM TO ANY PARTICULAR FONT, STYLE, SIZE, OR COLOR.

PRIORITY DATE OF 4-26-2010 IS CLAIMED.

OWNER OF INTERNATIONAL REGISTRATION 1045302 DATED 5-25-2010, EXPIRES 5-25-2020.

OWNER OF U.S. REG. NOS. 1,301,254, 2,308,518 AND OTHERS.

THE NAME(S), PORTRAIT(S), AND/OR SIGNATURE(S) SHOWN IN THE MARK DOES NOT IDENTIFY A PARTICULAR LIVING INDIVIDUAL.

FOR MACHINES FOR SIEVING, SEPARATING, STRAINING AND SCREENING MATERIALS USED IN ANY TYPE OF INDUSTRY, SUCH MATERIALS INCLUDING LIQUIDS, POWDERS, ROCKS, CHEMICALS, METALS, COATINGS, RESINS, PAINT, INK, DYES, CLAY, AND GRANULES; ULTRASONIC MACHINES FOR USE IN SIEVING AND FILTERING; MACHINE PARTS AND FITTINGS FOR THE AFORESAID GOODS, NAMELY, FILTERS, SIEVES, SCREENS, GASKETS, PADS, DISCS, BALLS, MOUNTS, BEARINGS, CLAMPS, COUPLINGS, WHEEL DRIVE SYSTEMS, PROBES, CABLES, BLADES, PINS, SEALS, SHAFTS, VALVES, MOTORS, GAUGES, MONITORING SYSTEMS (U.S. CLS. 13, 19, 21, 23, 31, 34 AND 35).

JESSICA FATHY, EXAMINING ATTORNEY

SN 79-086,438. SAGBILI MAKINE SANAYI TICARET LTD. STI., TURKEY, FILED 8-4-2010.

# Savema

OWNER OF INTERNATIONAL REGISTRATION 1048614 DATED 8-4-2010, EXPIRES 8-4-2020.

FOR PACKAGING MACHINES, THERMAL TRANSFER OVERPRINTING MACHINES, FILLING MACHINES, AUTOMATIC INDUSTRIAL LABELING MACHINES FOR APPLYING LABELS TO CONTAINERS AND BOTTLES, ELECTRONIC LABEL PRINTING MACHINES FOR COMMERCIAL USE, SORTING MACHINES (U.S. CLS. 13, 19, 21, 23, 31, 34 AND 35).

LEIGH LOWRY, EXAMINING ATTORNEY

**CLASS 7—(Continued).**

SN 79-087,195. NINGBO KINGONE INDUSTRIAL CO., LTD., CHINA, FILED 7-28-2010.



OWNER OF INTERNATIONAL REGISTRATION 1050657 DATED 7-28-2010, EXPIRES 7-28-2020.

THE TRADEMARK CONSISTS OF AN ARC DEVICE. IN THE MIDDLE OF THE ARC THERE IS THE WORD "KINGONE" IN CAPITAL LETTERS, AND UNDER THE WORD THERE ARE TWO CHINESE CHARACTERS.

THE ENGLISH TRANSLATION OF THE FOREIGN WORD(S) IN THE MARK IS: JIE MEANS VICTORY, TRIUMPH AND WANG MEANS KING; THE COMBINATION OF THE CHINESE CHARACTERS HAS NO SPECIFIC MEANING.

THE TRANSLITERATION OF THE NON-LATIN CHARACTERS IN THE MARK IS: JIE WANG.

FOR CAPSTANS; WINCHES; DERRICKS; HOISTING MACHINES; THREE-DIMENSIONAL GARAGE WITH ELEVATORS; NET HAULING MACHINES USED FOR FISHING; EXTRACTORS FOR MINES, NAMELY, MINE BORERS AND CONVEYORS; WINDING ENGINES NOT FOR LAND VEHICLES; HOIST TACKLES (U.S. CLS. 13, 19, 21, 23, 31, 34 AND 35).

JOSETTE BEVERLY, EXAMINING ATTORNEY

**CLASS 7—(Continued).**

SN 85-018,869. TELEDYNE TECHNOLOGIES INCORPORATED, THOUSAND OAKS, CA. FILED 4-20-2010.



OWNER OF U.S. REG. NOS. 1,497,421 AND 1,578,621.

THE MARK CONSISTS OF THE WORD "VOYAGER" IN STYLIZED FONT AND UNDERLINED, AND WITH GRAPHICAL LINES ABOVE AND TO THE LEFT OF THE WORD THAT FORM A STYLIZED CLOUD DESIGN.

FOR INTERNAL COMBUSTION ENGINES FOR AIRCRAFT (U.S. CLS. 13, 19, 21, 23, 31, 34 AND 35).

CURTIS FRENCH, EXAMINING ATTORNEY

SN 85-019,905. WEIR SLURRY GROUP, INC., MADISON, WI. FILED 4-21-2010.

SN 85-013,705. TECHTRONIC POWER TOOLS TECHNOLOGY LIMITED, ROAD TOWN, TORTOLA, BR.VIRGIN ISLANDS, FILED 4-14-2010.



**SPEED LOAD +**

THE MARK CONSISTS OF STANDARD CHARACTERS WITHOUT CLAIM TO ANY PARTICULAR FONT, STYLE, SIZE, OR COLOR.

OWNER OF U.S. REG. NO. 3,244,248.

FOR ELECTRIC DRILL ACCESSORIES, NAMELY, QUICK CHANGE BIT CONNECTORS AND BITS (U.S. CLS. 13, 19, 21, 23, 31, 34 AND 35).

FIRST USE 4-0-2005; IN COMMERCE 4-0-2005.

JANICE L. MCMORROW, EXAMINING ATTORNEY

THE MARK CONSISTS OF STANDARD CHARACTERS WITHOUT CLAIM TO ANY PARTICULAR FONT, STYLE, SIZE, OR COLOR.

FOR CENTRIFUGAL PUMPS AND PARTS THEREFOR, NAMELY, PUMP CASINGS, PUMP FRAMES, PUMP BEARING ASSEMBLIES; PUMP HOUSINGS FOR CENTRIFUGAL PUMPS, NAMELY, COVER PLATES; THROAT BUSHES AND LINERS FOR CENTRIFUGAL PUMPS; THROAT BUSH AND LINER ADJUSTMENT MECHANISMS FOR CENTRIFUGAL PUMPS; PUMP SEAL ASSEMBLIES FOR CENTRIFUGAL PUMPS HAVING HYDRODYNAMIC AND/OR MECHANICAL SEAL ASSEMBLIES AND THE COMPONENTS THEREFOR; EXPELLERS FOR CENTRIFUGAL PUMPS; IMPELLERS FOR CENTRIFUGAL PUMPS; PEDESTALS AND BASES SPECIALLY ADAPTED FOR CENTRIFUGAL PUMPS; AND IMPELLER RELEASE MECHANISMS FOR CENTRIFUGAL PUMPS; ALL OF THE ABOVE FOR USE IN THE ORE PROCESSING MILL INDUSTRY AND MINING INDUSTRY (U.S. CLS. 13, 19, 21, 23, 31, 34 AND 35).

KATHERINE CONNOLLY, EXAMINING ATTORNEY

**CLASS 7—(Continued).**

SN 85-019,914. WEIR SLURRY GROUP, INC., MADISON, WI.  
FILED 4-21-2010.

# MCR

THE MARK CONSISTS OF STANDARD CHARACTERS WITHOUT CLAIM TO ANY PARTICULAR FONT, STYLE, SIZE, OR COLOR.

FOR CENTRIFUGAL PUMPS AND PARTS THEREFOR, NAMELY, PUMP CASINGS, PUMP FRAMES, PUMP BEARING ASSEMBLIES; PUMP HOUSINGS FOR CENTRIFUGAL PUMPS, NAMELY, COVER PLATES; THROAT BUSHES AND LINERS FOR CENTRIFUGAL PUMPS; THROAT BUSH AND LINER ADJUSTMENT MECHANISMS FOR CENTRIFUGAL PUMPS; PUMP SEAL ASSEMBLIES FOR CENTRIFUGAL PUMPS HAVING HYDRODYNAMIC AND/OR MECHANICAL SEAL ASSEMBLIES AND THE COMPONENTS THEREFOR; EXPELLERS FOR CENTRIFUGAL PUMPS; IMPELLERS FOR CENTRIFUGAL PUMPS; PEDESTALS AND BASES SPECIALLY ADAPTED FOR CENTRIFUGAL PUMPS; AND IMPELLER RELEASE MECHANISMS FOR CENTRIFUGAL PUMPS (U.S. CLS. 13, 19, 21, 23, 31, 34 AND 35).

KATHERINE CONNOLLY, EXAMINING ATTORNEY

SN 85-019,924. WEIR SLURRY GROUP, INC., MADISON, WI.  
FILED 4-21-2010.

# MCU

THE MARK CONSISTS OF STANDARD CHARACTERS WITHOUT CLAIM TO ANY PARTICULAR FONT, STYLE, SIZE, OR COLOR.

FOR CENTRIFUGAL PUMPS AND PARTS THEREFOR, NAMELY, PUMP CASINGS, PUMP FRAMES, PUMP BEARING ASSEMBLIES; PUMP HOUSINGS FOR CENTRIFUGAL PUMPS, NAMELY, COVER PLATES; THROAT BUSHES AND LINERS FOR CENTRIFUGAL PUMPS; THROAT BUSH AND LINER ADJUSTMENT MECHANISMS FOR CENTRIFUGAL PUMPS; PUMP SEAL ASSEMBLIES FOR CENTRIFUGAL PUMPS HAVING HYDRODYNAMIC AND/OR MECHANICAL SEAL ASSEMBLIES AND THE COMPONENTS THEREFOR; EXPELLERS FOR CENTRIFUGAL PUMPS; IMPELLERS FOR CENTRIFUGAL PUMPS; PEDESTALS AND BASES SPECIALLY ADAPTED FOR CENTRIFUGAL PUMPS; AND IMPELLER RELEASE MECHANISMS FOR CENTRIFUGAL PUMPS (U.S. CLS. 13, 19, 21, 23, 31, 34 AND 35).

KATHERINE CONNOLLY, EXAMINING ATTORNEY

**CLASS 7—(Continued).**

SN 85-020,416. PRECO, INC., LENEXA, KS. FILED 4-22-2010.

# WEBPRO

THE MARK CONSISTS OF STANDARD CHARACTERS WITHOUT CLAIM TO ANY PARTICULAR FONT, STYLE, SIZE, OR COLOR.

FOR LASER MACHINES FOR WEB-BASED LASER CUTTING, SCORING, SLITTING, AND KISS-CUTTING OF METALS AND NON-METALS (U.S. CLS. 13, 19, 21, 23, 31, 34 AND 35).

FIRST USE 4-0-2006; IN COMMERCE 4-0-2006.

HANNO RITTNER, EXAMINING ATTORNEY

SN 85-026,997. SCHAEFFLER TECHNOLOGIES GMBH & CO. KG, HERZOGENAURACH, FED REP GERMANY,  
FILED 4-30-2010.

# BARDEN

THE MARK CONSISTS OF STANDARD CHARACTERS WITHOUT CLAIM TO ANY PARTICULAR FONT, STYLE, SIZE, OR COLOR.

OWNER OF U.S. REG. NO. 548,207.

SEC. 2(F).

FOR MACHINE PARTS, NAMELY, BALL BEARINGS; MACHINE PARTS, NAMELY, BALL SCREW SUPPORT BEARINGS; MACHINE PARTS, NAMELY, CYLINDRICAL ROLLER BEARINGS; MACHINE PARTS, NAMELY, DOUBLE DIRECTION ANGULAR CONTACT THRUST BALL BEARINGS (U.S. CLS. 13, 19, 21, 23, 31, 34 AND 35).

FIRST USE 4-30-1965; IN COMMERCE 4-30-1965.

JOHN DWYER, EXAMINING ATTORNEY

SN 85-031,852. ATI STELLRAM SA, GLAND, SWITZERLAND, FILED 5-6-2010.

# AEROSTELL

THE MARK CONSISTS OF STANDARD CHARACTERS WITHOUT CLAIM TO ANY PARTICULAR FONT, STYLE, SIZE, OR COLOR.

OWNER OF U.S. REG. NO. 1,565,475.

FOR MILLING CUTTERS WITH REMOVABLE OR BRAZED HARD METAL CUTTING BITS, FOR USE ON MACHINE TOOLS; HARD METAL CUTTING BITS, CARTRIDGES AND SCREWS FOR THESE MILLING CUTTERS (U.S. CLS. 13, 19, 21, 23, 31, 34 AND 35).

FIRST USE 11-14-1989; IN COMMERCE 11-14-1989.

GINA HAYES, EXAMINING ATTORNEY

**CLASS 7—(Continued).**

SN 85-040,346. AIRGAS, INC., RADNOR, PA. FILED 5-17-2010.

# AIR BOSS

THE MARK CONSISTS OF STANDARD CHARACTERS WITHOUT CLAIM TO ANY PARTICULAR FONT, STYLE, SIZE, OR COLOR.

NO CLAIM IS MADE TO THE EXCLUSIVE RIGHT TO USE "AIR", APART FROM THE MARK AS SHOWN.

FOR TRAILER-MOUNTED AIR COMPRESSOR SYSTEM COMPRISED OF AN AIR COMPRESSOR, COOLING AIR UNIT, AIR FILTRATION DEVICE, AIR ANALYZER AND MONITORING SYSTEM, THAT DELIVERS FILTERED AND COOLED GRADE D BREATHING AIR USING BREATHING AIR LINES AND RESPIRATOR/FACE MASKS FOR UP TO ONE HUNDRED WORKERS ON A JOB SITE (U.S. CLS. 13, 19, 21, 23, 31, 34 AND 35).

CURTIS FRENCH, EXAMINING ATTORNEY

**CLASS 7—(Continued).**

SN 85-046,978. GLOBAL TECH APPLIANCES (HK) LIMITED, KOWLOON, HONG KONG, FILED 5-25-2010.

# MAGIC MIX

THE MARK CONSISTS OF STANDARD CHARACTERS WITHOUT CLAIM TO ANY PARTICULAR FONT, STYLE, SIZE, OR COLOR.

NO CLAIM IS MADE TO THE EXCLUSIVE RIGHT TO USE "MIX", APART FROM THE MARK AS SHOWN.

FOR SMALL ELECTRIC KITCHEN APPLIANCES, NAMELY, ELECTRIC FOOD BLENDERS, ELECTRIC HAND MIXERS, ELECTRIC STAND MIXERS AND ELECTRIC FOOD PROCESSORS (U.S. CLS. 13, 19, 21, 23, 31, 34 AND 35).

TASNEEM HUSSAIN, EXAMINING ATTORNEY

SN 85-052,396. MIDWEST INDUSTRIAL SUPPLY, INC., CANTON, OH. FILED 6-2-2010.

# COAL CARTOPPING SYSTEM

THE MARK CONSISTS OF STANDARD CHARACTERS WITHOUT CLAIM TO ANY PARTICULAR FONT, STYLE, SIZE, OR COLOR.

NO CLAIM IS MADE TO THE EXCLUSIVE RIGHT TO USE "COAL" AND "SYSTEM", APART FROM THE MARK AS SHOWN.

FOR DUST SUPPRESSION SYSTEMS COMPRISED OF CONTROL PANELS, POWER SUPPLY MODULES, STORAGE TANKS, PUMPS, MOTORS, PRESSURE REGULATORS, CONTROL VALVES, NOZZLES, AND HOSES FOR SPRAYING A CHEMICAL ADHESIVE USED IN CEMENTING SURFACE DUST AND SURFACE PARTICLES TOGETHER AND THEN CEMENTING THE BOUND SURFACE LAYER TO A SUBBASE ONTO OPEN-TOP RAILWAY CARS FOR THE PURPOSES OF PREVENTING FLY-AWAY DUST (U.S. CLS. 13, 19, 21, 23, 31, 34 AND 35).

FIRST USE 9-30-2006; IN COMMERCE 9-30-2006.  
ANNE FARRELL, EXAMINING ATTORNEY

SN 85-046,945. GLOBAL TECH APPLIANCES (HK) LIMITED, KOWLOON, HONG KONG, FILED 5-25-2010.



THE COLOR(S) RED AND WHITE IS/ARE CLAIMED AS A FEATURE OF THE MARK.

THE MARK CONSISTS OF THE WORD "MAGICMIX" WRITTEN DIAGONALLY AND UNDERLINED IN RED COLOR ON A WHITE BACKGROUND.

FOR SMALL ELECTRIC KITCHEN APPLIANCES, NAMELY, ELECTRIC FOOD BLENDERS, ELECTRIC HAND MIXERS, ELECTRIC STAND MIXERS AND ELECTRIC FOOD PROCESSORS (U.S. CLS. 13, 19, 21, 23, 31, 34 AND 35).

TASNEEM HUSSAIN, EXAMINING ATTORNEY



**CLASS 7—(Continued).**

SN 85-070,799. EVANTAGE TECHNOLOGIES LLC, WATER-TOWN, CT. FILED 6-24-2010.

**MicroCARB**

THE MARK CONSISTS OF STANDARD CHARACTERS WITHOUT CLAIM TO ANY PARTICULAR FONT, STYLE, SIZE, OR COLOR.

FOR CARBONATORS FOR USE WITH BEVERAGE DISPENSING MACHINES, NAMELY, IN-LINE APPARATUS FOR DISSOLVING CARBON DIOXIDE GAS IN SUPPLIED FLUIDS; APPARATUS FOR ADJUSTING FOR CHANGES IN THE TEMPERATURE OF THE SUPPLIED FLUIDS FEATURING REGULATORS BEING PARTS OF MACHINES (U.S. CLS. 13, 19, 21, 23, 31, 34 AND 35).

EMILY CHUO, EXAMINING ATTORNEY

SN 85-075,155. HELICAL ROBOTICS, LLC, OREGON, WI. FILED 6-30-2010.

**HELICAL ROBOTICS**

THE MARK CONSISTS OF STANDARD CHARACTERS WITHOUT CLAIM TO ANY PARTICULAR FONT, STYLE, SIZE, OR COLOR.

NO CLAIM IS MADE TO THE EXCLUSIVE RIGHT TO USE "ROBOTICS", APART FROM THE MARK AS SHOWN. FOR INDUSTRIAL ROBOTS (U.S. CLS. 13, 19, 21, 23, 31, 34 AND 35).

EMILY CHUO, EXAMINING ATTORNEY

SN 85-078,790. HANDI QUILTER, INC., NORTH SALT LAKE, UT. FILED 7-6-2010.



OWNER OF U.S. REG. NOS. 2,920,821, 3,559,066 AND OTHERS.

NO CLAIM IS MADE TO THE EXCLUSIVE RIGHT TO USE "HANDY QUILTER", APART FROM THE MARK AS SHOWN.

THE MARK CONSISTS OF A STYLIZED IMAGE OF A NEEDLE AND THREAD TO THE LEFT OF THE WORDS "HANDI QUILTER", WITH THE THREAD CONTINUING BELOW THE WORDS AS A DASHED LINE.

FOR SEWING MACHINES DESIGNED FOR QUILTING; PORTABLE QUILTING FRAMES, EACH WITH A CARRIAGE WHICH ATTACHES TO A SEWING MACHINE FOR THE MAKING OF QUILTS (U.S. CLS. 13, 19, 21, 23, 31, 34 AND 35).

FIRST USE 1-1-2006; IN COMMERCE 1-1-2006.  
RONALD AIKENS, EXAMINING ATTORNEY

**CLASS 7—(Continued).**

SN 85-084,077. TREX COMPANY, INC., WINCHESTER, VA. FILED 7-14-2010.

**CustomCurve**

THE MARK CONSISTS OF STANDARD CHARACTERS WITHOUT CLAIM TO ANY PARTICULAR FONT, STYLE, SIZE, OR COLOR.

FOR PORTABLE PROPANE AND ELECTRIC HEAT BENDING MACHINES FOR HEATING AND BENDING COMPOSITE DECKING, DECK RAILING AND DECK TRIM COMPRISED OF WOOD FIBER AND POLYMER (U.S. CLS. 13, 19, 21, 23, 31, 34 AND 35).

ANDREW RHIM, EXAMINING ATTORNEY

SN 85-130,417. JENSEN USA, INC., PANAMA CITY, FL. FILED 9-15-2010.



OWNER OF U.S. REG. NO. 2,308,590.

THE MARK CONSISTS OF THE STYLIZED WORD "JENSEN" INSIDE A QUADRILATERAL SURROUNDED BY A LARGER QUADRILATERAL.

SEC. 2(F).

FOR LAUNDRY MACHINERY AND GARMENT FINISHING MACHINERY, NAMELY, SPREADERS, FEEDERS, FOLDERS, STACKERS, SORTERS, WASHERS, PRESSES, EXTRACTORS, AND IRONERS (U.S. CLS. 13, 19, 21, 23, 31, 34 AND 35).

FIRST USE 8-1-1966; IN COMMERCE 8-1-1966.

ANDREW RHIM, EXAMINING ATTORNEY

SN 85-131,652. KEITH MANUFACTURING CO., MADRAS, OR. FILED 9-16-2010.

**PRESSURE SEAL**

THE MARK CONSISTS OF STANDARD CHARACTERS WITHOUT CLAIM TO ANY PARTICULAR FONT, STYLE, SIZE, OR COLOR.

SEC. 2(F).

FOR RECIPROCATING FLOOR CONVEYORS (U.S. CLS. 13, 19, 21, 23, 31, 34 AND 35).

FIRST USE 5-12-1997; IN COMMERCE 5-12-1997.

TINA MAI, EXAMINING ATTORNEY

**CLASS 7—(Continued).**

SN 85-136,267. PACKAGING PROGRESSIONS, INC., COLLEGEVILLE, PA. FILED 9-23-2010.

**PRO LEAVER**

THE MARK CONSISTS OF STANDARD CHARACTERS WITHOUT CLAIM TO ANY PARTICULAR FONT, STYLE, SIZE, OR COLOR.

THE WORD "PRO LEAVER" APPEARING IN THE MARK HAS NO SIGNIFICANCE NOR IS IT A TERM OF ART IN THE RELEVANT TRADE OR INDUSTRY OR AS APPLIED TO THE GOODS/SERVICES LISTED IN THE APPLICATION, OR ANY GEOGRAPHICAL SIGNIFICANCE.

FOR FOOD PROCESSING EQUIPMENT, NAMELY, MACHINES FOR INSERTING SEPARATION SHEETS UNDER FOOD AND NONFOOD SLICES (U.S. CLS. 13, 19, 21, 23, 31, 34 AND 35).

SUE LAWRENCE, EXAMINING ATTORNEY

SN 85-153,676. G.T.E. INDUSTRIES INC., LINCOLN, NE. FILED 10-15-2010.

**GT EXHAUST**

THE MARK CONSISTS OF STANDARD CHARACTERS WITHOUT CLAIM TO ANY PARTICULAR FONT, STYLE, SIZE, OR COLOR.

NO CLAIM IS MADE TO THE EXCLUSIVE RIGHT TO USE "EXHAUST", APART FROM THE MARK AS SHOWN.

FOR EXHAUST MANIFOLDS FOR ENGINES; EXHAUST SILENCERS FOR ENGINES; EXHAUST ACCESSORIES FOR ENGINES, NAMELY, CORRUGATED FLEX CONNECTORS FOR CONNECTING THE EXHAUST TO THE ENGINE, WYE CONNECTORS USED TO CONNECT EXHAUST USED WITH DUAL OUTLET ENGINES, EXHAUST THIMBLES USED TO PROVIDE SEPARATION BETWEEN THE EXHAUST PIPE AND THE WALLS AND CEILING, AND OUTLET EXTENSIONS USED TO EXTEND AN EXHAUST PIPE; THERMAL INSULATING WRAPS FOR ENGINES SOLD AS AN INTEGRAL PART OF ENGINES; ENGINE PARTS, NAMELY, THREE-WAY, OXIDATION AND DIESEL OXIDATION CATALYSTS; DIESEL FUEL PARTICULATE FILTERS (U.S. CLS. 13, 19, 21, 23, 31, 34 AND 35).

CHERYL CLAYTON, EXAMINING ATTORNEY

**CLASS 7—(Continued).**

SN 85-153,679. G.T.E. INDUSTRIES INC., LINCOLN, NE. FILED 10-15-2010.



NO CLAIM IS MADE TO THE EXCLUSIVE RIGHT TO USE "EXHAUST", APART FROM THE MARK AS SHOWN.

THE MARK CONSISTS OF A SHIELD DESIGN CONTAINING A DIAMOND SHAPE INSIDE OF THREE CIRCLES, ALONGSIDE THE TERM "GT EXHAUST".

FOR EXHAUST MANIFOLDS FOR ENGINES; EXHAUST SILENCERS FOR ENGINES; EXHAUST ACCESSORIES FOR ENGINES, NAMELY, CORRUGATED FLEX CONNECTORS FOR CONNECTING THE EXHAUST TO THE ENGINE, WYE CONNECTORS USED TO CONNECT EXHAUST USED WITH DUAL OUTLET ENGINES, EXHAUST THIMBLES USED TO PROVIDE SEPARATION BETWEEN THE EXHAUST PIPE AND THE WALLS AND CEILING, AND OUTLET EXTENSIONS USED TO EXTEND AN EXHAUST PIPE; THERMAL INSULATING WRAPS FOR ENGINES SOLD AS AN INTEGRAL PART OF ENGINES; ENGINE PARTS, NAMELY, THREE-WAY, OXIDATION AND DIESEL OXIDATION CATALYSTS; DIESEL FUEL PARTICULATE FILTERS (U.S. CLS. 13, 19, 21, 23, 31, 34 AND 35).

CHERYL CLAYTON, EXAMINING ATTORNEY

SN 85-156,177. PENTAIR WATER POOL AND SPA, INC., SANFORD, NC. FILED 10-19-2010.

**Max-E-ProXF**

THE MARK CONSISTS OF STANDARD CHARACTERS WITHOUT CLAIM TO ANY PARTICULAR FONT, STYLE, SIZE, OR COLOR.

OWNER OF U.S. REG. NOS. 1,488,159 AND 2,181,371. FOR CENTRIFUGAL PUMPS FOR SWIMMING POOLS, SPAS, AND WATER PARKS (U.S. CLS. 13, 19, 21, 23, 31, 34 AND 35).

COURTNEY ALVAREZ, EXAMINING ATTORNEY

SN 85-156,268. AMANA TOOL CORPORATION, FARMINGDALE, NY. FILED 10-19-2010.

**ARMORMAX**

THE MARK CONSISTS OF STANDARD CHARACTERS WITHOUT CLAIM TO ANY PARTICULAR FONT, STYLE, SIZE, OR COLOR.

FOR SAW BLADES FOR CIRCULAR POWER SAWS (U.S. CLS. 13, 19, 21, 23, 31, 34 AND 35).

FIRST USE 10-4-2010; IN COMMERCE 10-4-2010.

JACLYN KIDWELL WALKER, EXAMINING ATTORNEY

**CLASS 7—(Continued).**

SN 85-157,074. PENTAIR WATER POOL AND SPA, INC.,  
SANFORD, NC. FILED 10-20-2010.

# Max-E-Pro

THE MARK CONSISTS OF STANDARD CHARACTERS  
WITHOUT CLAIM TO ANY PARTICULAR FONT, STYLE,  
SIZE, OR COLOR.

OWNER OF U.S. REG. NOS. 1,488,159 AND 2,181,371.  
FOR CENTRIFUGAL PUMPS FOR SWIMMING  
POOLS, SPAS, AND WATER PARKS (U.S. CLS. 13, 19,  
21, 23, 31, 34 AND 35).

FIRST USE 1-1-2004; IN COMMERCE 1-1-2004.  
COURTNEY ALVAREZ, EXAMINING ATTORNEY

SN 85-157,941. IRWIN INDUSTRIAL TOOL COMPANY,  
ATLANTA, GA. FILED 10-21-2010.

# LENOX CLASSIC PRO

THE MARK CONSISTS OF STANDARD CHARACTERS  
WITHOUT CLAIM TO ANY PARTICULAR FONT, STYLE,  
SIZE, OR COLOR.

OWNER OF U.S. REG. NOS. 1,216,425, 3,438,186 AND  
OTHERS.

NO CLAIM IS MADE TO THE EXCLUSIVE RIGHT TO  
USE "PRO", APART FROM THE MARK AS SHOWN.

FOR BLADES FOR POWER SAWS (U.S. CLS. 13, 19, 21,  
23, 31, 34 AND 35).

EDWARD NELSON, EXAMINING ATTORNEY

SN 85-158,181. NEWLY FOUND ENERGY, INC., WEST  
LONG BRANCH, NJ. FILED 10-21-2010.

# Natural Gastation

THE MARK CONSISTS OF STANDARD CHARACTERS  
WITHOUT CLAIM TO ANY PARTICULAR FONT, STYLE,  
SIZE, OR COLOR.

NO CLAIM IS MADE TO THE EXCLUSIVE RIGHT TO  
USE "NATURAL", APART FROM THE MARK AS SHOWN.

FOR ELECTRIC GENERATORS; GAS COMPRESSORS  
(U.S. CLS. 13, 19, 21, 23, 31, 34 AND 35).

LINDA E. BLOHM, EXAMINING ATTORNEY

**CLASS 7—(Continued).**

SN 85-159,587. TIFCO INDUSTRIES, INC, CYPRESS, TX.  
FILED 10-22-2010.

# KRIMPMASTER

THE MARK CONSISTS OF STANDARD CHARACTERS  
WITHOUT CLAIM TO ANY PARTICULAR FONT, STYLE,  
SIZE, OR COLOR.

FOR ELECTRIC CRIMPING MACHINES (U.S. CLS. 13,  
19, 21, 23, 31, 34 AND 35).

FIRST USE 2-5-2010; IN COMMERCE 9-17-2010.  
EUGENIA MARTIN, EXAMINING ATTORNEY

SN 85-174,613. SCAT ENTERPRISES, INC., REDONDO  
BEACH, CA. FILED 11-11-2010.



OWNER OF U.S. REG. NOS. 3,217,216 AND 3,222,015.  
THE MARK CONSISTS OF THE TERM "SCAT" PRE-  
SENTED IN FANCIFUL LETTERING.

FOR CRANKSHAFTS AND PULLEYS FOR LAND  
VEHICLES; BILLET CRANKSHAFTS AND CONNECT-  
ING RODS FOR LAND VEHICLES; LIGHTWEIGHT  
BILLET CRANKSHAFTS FOR LAND VEHICLES; CAR-  
BURETORS; THROTTLES AS PARTS OF CARBURE-  
TORS; DISTRIBUTORS FOR VEHICLES; DISTRIBUTOR  
DRIVE PULLEYS FOR LAND VEHICLES; ALTERNA-  
TORS FOR LAND VEHICLES; LAND VEHICLE INTER-  
NAL COMBUSTION ENGINE PARTS, NAMELY, VALVE  
COVERS, CYLINDER COVERS, RADIATOR FAN HOU-  
SINGS, COOLING FANS, AIR CLEANERS, AUTOMOTIVE  
INTAKE MANIFOLDS, CARBURETOR LINKAGES,  
CONNECTING RODS, DISTRIBUTOR CLAMPS, COIL  
COVERS, ELECTRIC GENERATOR COVERS, OIL COOL-  
ERS, OIL PUMPS, OIL BREATHERS, BREATHER CAPS,  
OIL GALLEY PLUGS, OIL PUMPS, FILTER PUMPS, OIL  
FILTER BRACKETS, OIL COOLER BYPASS ADAPTORS,  
EXHAUST EXTENSIONS, HEATER HOSES, FLY-  
WHEELS, STARTER BUSHINGS, GLAND NUT AND  
WASHER, SWAY BARS; PULLEY BELTS; AUTOMOBILE  
OIL PANS; ELECTRIC GENERATOR AND ALTERNA-  
TOR PULLEYS FOR LAND VEHICLES; MUFFLERS FOR  
MOTORS AND ENGINES; MOUNTS FOR MUFFLERS  
FOR MOTORS AND ENGINES; DIP STICKS; AND LAND  
VEHICLE PARTS, NAMELY, EXHAUST PIPES, TAIL  
PIPES, CROSS-OVER PIPES - ALL OF THE AFOREMEN-  
TIONED GOODS ONLY FOR THE PERFORMANCE  
AFTERMARKET FOR CARS, TRUCKS, AND AIR-  
CRAFTS, SPECIFICALLY EXCLUDING THE AFTER-  
MARKET FOR BOATS, CONSTRUCTION AND  
MINING MACHINERY (U.S. CLS. 13, 19, 21, 23, 31, 34  
AND 35).

FIRST USE 10-15-1966; IN COMMERCE 10-15-1966.  
DAWN FELDMAN, EXAMINING ATTORNEY

**CLASS 7—(Continued).**

SN 85-175,534. JACKSON MSC LLC, WILMINGTON, DE.  
FILED 11-12-2010.

**CONSERVER EXTREME**

THE MARK CONSISTS OF STANDARD CHARACTERS  
WITHOUT CLAIM TO ANY PARTICULAR FONT, STYLE,  
SIZE, OR COLOR.

OWNER OF U.S. REG. NO. 3,347,420.  
FOR DISHWASHERS (U.S. CLS. 13, 19, 21, 23, 31, 34  
AND 35).

ROBERT STRUCK, EXAMINING ATTORNEY

SN 85-177,805. BROTHER INDUSTRIES, LTD., NAGOYA,  
JAPAN, FILED 11-16-2010.



THE MARK CONSISTS OF THE STYLIZED WORDING  
"BROTHER".

FOR GEAR MOTORS NOT FOR LAND VEHICLES  
(U.S. CLS. 13, 19, 21, 23, 31, 34 AND 35).

FIRST USE 2-3-1993; IN COMMERCE 2-3-1993.  
TRACY FLETCHER, EXAMINING ATTORNEY

SN 85-178,434. ARC LITE POWER, LLC, SAN DIEGO, CA.  
FILED 11-16-2010.

**Electra-Jet**

THE MARK CONSISTS OF STANDARD CHARACTERS  
WITHOUT CLAIM TO ANY PARTICULAR FONT, STYLE,  
SIZE, OR COLOR.

FOR MARINE ENGINES AND PARTS AND FITTINGS  
THEREOF, NAMELY ELECTRICALLY-POWERED  
WATER-JET MARINE VEHICLE PROPULSION UNITS  
(U.S. CLS. 13, 19, 21, 23, 31, 34 AND 35).

BRIAN NEVILLE, EXAMINING ATTORNEY

SN 85-179,756. CARPENTER, BRADFORD, SR., WHITE  
BEAR LAKE, MN. FILED 11-18-2010.

**STEALTH PALLET**

THE MARK CONSISTS OF STANDARD CHARACTERS  
WITHOUT CLAIM TO ANY PARTICULAR FONT, STYLE,  
SIZE, OR COLOR.

FOR SILK SCREEN PRINTING MACHINES (U.S. CLS.  
13, 19, 21, 23, 31, 34 AND 35).

DOUGLAS LEE, EXAMINING ATTORNEY

**CLASS 7—(Continued).**

SN 85-181,200. MUFFLER MAN SUPPLY COMPANY, FLINT,  
MI. FILED 11-19-2010.

**STEALTH**

THE MARK CONSISTS OF STANDARD CHARACTERS  
WITHOUT CLAIM TO ANY PARTICULAR FONT, STYLE,  
SIZE, OR COLOR.

FOR EXHAUST MUFFLERS FOR MOTORS, ENGINE  
EXHAUST SYSTEMS COMPRISED OF PIPES, CONNec-  
TORS AND MUFFLERS (U.S. CLS. 13, 19, 21, 23, 31, 34  
AND 35).

LINDA E. BLOHM, EXAMINING ATTORNEY

**CLASS 8—HAND TOOLS**

SN 77-958,662. AMES TRUE TEMPER, INC., CAMP HILL, PA.  
FILED 3-15-2010.

**TRUE TEMPER**

THE MARK CONSISTS OF STANDARD CHARACTERS  
WITHOUT CLAIM TO ANY PARTICULAR FONT, STYLE,  
SIZE, OR COLOR.

FOR HAMMERS (U.S. CLS. 23, 28 AND 44).  
CHERYL CLAYTON, EXAMINING ATTORNEY

SN 79-084,100. KONINKLIJKE PHILIPS ELECTRONICS N.V.,  
NL-5621 BA EINDHOVEN, NETHERLANDS, FILED 5-31-  
2010.

**SENSOTOUCH3D**

THE MARK CONSISTS OF STANDARD CHARACTERS  
WITHOUT CLAIM TO ANY PARTICULAR FONT, STYLE,  
SIZE, OR COLOR.

PRIORITY DATE OF 1-13-2010 IS CLAIMED.  
OWNER OF INTERNATIONAL REGISTRATION 1042881  
DATED 5-31-2010, EXPIRES 5-31-2020.

FOR ELECTRIC SHAVERS, BLADES FOR ELECTRIC  
SHAVERS, HAIR CLIPPERS, HAIR AND BEARD TRIM-  
MERS; PARTS OF THE AFORESAID GOODS (U.S. CLS.  
23, 28 AND 44).

HELENE LIWINSKI, EXAMINING ATTORNEY

**CLASS 8—(Continued).**

SN 85-078,797. HANDI QUILTER, INC., NORTH SALT LAKE, UT. FILED 7-6-2010.



OWNER OF U.S. REG. NOS. 2,920,821, 3,559,066 AND OTHERS.

NO CLAIM IS MADE TO THE EXCLUSIVE RIGHT TO USE "HANDY QUILTER", APART FROM THE MARK AS SHOWN.

THE MARK CONSISTS OF A STYLIZED IMAGE OF A NEEDLE AND THREAD TO THE LEFT OF THE WORDS "HANDI QUILTER", WITH THE THREAD CONTINUING BELOW THE WORDS AS A DASHED LINE.

FOR HAND-OPERATED QUILTING MACHINE TOOLS USED TO ASSIST IN QUILTING (U.S. CLS. 23, 28 AND 44).

FIRST USE 3-1-2006; IN COMMERCE 3-1-2006.  
RONALD AIKENS, EXAMINING ATTORNEY

**CLASS 8—(Continued).**

SN 85-094,564. ECOLAB USA INC., SAINT PAUL, MN. FILED 7-28-2010.

**ECOLAB**

THE MARK CONSISTS OF STANDARD CHARACTERS WITHOUT CLAIM TO ANY PARTICULAR FONT, STYLE, SIZE, OR COLOR.

OWNER OF U.S. REG. NOS. 1,497,423, 1,538,458 AND OTHERS.

FOR BLADES FOR UTILITY KNIVES; HAND TOOLS, NAMELY, HAND OPERATED PUMPS; KNIFE SHARPENERS; KNIFE SHEATHS; KNIVES, NAMELY, PARING, BONING, CARVING, CHEF, KITCHEN, SERRATED, SCALLOPED, UTILITY AND VEGETABLE; MAGNETIC HAND-OPERATED RETRIEVER TOOL, NAMELY, A MAGNETIC FLATWARE RETRIEVER FOR PREVENTING INADVERTENT DISPOSAL OF FLATWARE; NON-ELECTRIC CAN OPENER; SCISSORS; SHEARS; TWEEZERS; SCREWDRIVERS; HANDTOOLS BEING MULTI-FUNCTION POCKETKNIVES (U.S. CLS. 23, 28 AND 44).

FIRST USE 2-0-2004; IN COMMERCE 2-0-2004.  
BRENDAN REGAN, EXAMINING ATTORNEY

SN 85-115,894. SUN JOO PARK, GAINESVILLE, FL. FILED 8-25-2010.

SN 85-090,393. CARLISLE INTANGIBLE COMPANY, SYRACUSE, NY. FILED 7-22-2010.

**BIG SHOT**

THE MARK CONSISTS OF STANDARD CHARACTERS WITHOUT CLAIM TO ANY PARTICULAR FONT, STYLE, SIZE, OR COLOR.

FOR BELT TENSIONING DEVICES, NAMELY, HAND TOOLS FOR USE IN SETTING THE TENSION ON POWER TRANSMISSION BELTS (U.S. CLS. 23, 28 AND 44).

BILL DAWE, EXAMINING ATTORNEY



THE MARK CONSISTS OF A CHINESE CHARACTERS ABOVE THE WORDING "AKIKO".

THE ENGLISH TRANSLATION OF "AKIKO" IN THE MARK IS "AUTUMN CHILD".

THE NON-LATIN CHARACTERS IN THE MARK TRANSLITERATE TO "AKI" AND THIS MEANS "AUTUMN" IN ENGLISH.

FOR HAIR CUTTING SCISSORS (U.S. CLS. 23, 28 AND 44).

FIRST USE 5-1-2010; IN COMMERCE 5-1-2010.  
PRISCILLA MILTON, EXAMINING ATTORNEY

**CLASS 8—(Continued).**

SN 85-137,385. PARK, IL-YONG, SEOUL, REPUBLIC OF KOREA, FILED 9-24-2010.



NO CLAIM IS MADE TO THE EXCLUSIVE RIGHT TO USE "PROFESSIONAL", APART FROM THE MARK AS SHOWN.

THE MARK CONSISTS OF THE STYLIZED WORDING "DAILY BLOSSOM PROFESSIONAL" WITH THE FIRST "O" IN "BLOSSOM" REPRESENTED BY A STYLIZED FLOWER DESIGN ELEMENT. THE TERM "DAILY BLOSSOM" IS UNDERLINED AND THE WORD "PROFESSIONAL" APPEARS BENEATH THE TERM "DAILY BLOSSOM".

FOR NAIL FILES, NON-ELECTRIC FINGERNAIL POLISHERS, ELECTRIC FINGERNAIL POLISHERS, HAIR-REMOVING TWEEZERS, FINGERNAIL CLIPPERS, NON-ELECTRIC FINGERNAIL CLIPPERS, ELECTRIC FINGERNAIL CLIPPERS, EYELASH CURLERS, NAIL SCISSORS, NAIL NIPPERS, CUTICLE NIPPERS, FILE FOR REMOVING HARDENED SKIN, EAR-PIERCING APPARATUS, MANICURE SETS, AND PEDICURE SETS (U.S. CLS. 23, 28 AND 44).  
GEOFFREY FOSDICK, EXAMINING ATTORNEY

SN 85-147,288. FORTNER, BILL, GILLETTE, WY. FILED 10-7-2010.



NO CLAIM IS MADE TO THE EXCLUSIVE RIGHT TO USE "WYOMING BRAND COMPANY", APART FROM THE MARK AS SHOWN.

THE MARK CONSISTS OF A CIRCLE WITH THE WORDS "OLD WYOMING BRAND COMPANY" ON THE UPPER PART OF THE CIRCLE, "BUILT TO LAST" ON THE LOWER PART OF THE CIRCLE, AND A BRAND IN THE MIDDLE OF THE CIRCLE.

FOR HAND CRANK JACKS AND ADJUSTABLE RECEIVER HITCHES FOR VEHICLES, PACKAGED AND SOLD TOGETHER (U.S. CLS. 23, 28 AND 44).  
MARK SPARACINO, EXAMINING ATTORNEY

**CLASS 8—(Continued).**

SN 85-152,167. SLEEPPISTOL, MIAMI, FL. FILED 10-13-2010.



THE MARK CONSISTS OF STANDARD CHARACTERS WITHOUT CLAIM TO ANY PARTICULAR FONT, STYLE, SIZE, OR COLOR.

FOR PORTABLE HAND-OPERATED, BATTERY-POWERED GRIP RESPONSIVE SLEEP ALERT DEVICE, NOT FOR MEDICAL PURPOSES, TO PREVENT UNWANTED DOZING OR SLEEP THAT IS ACTIVATED WHEN A SWITCH THAT IS NORMALLY CLOSED BY A SPRING IS OPENED BY THE USER'S HAND-GRIP (U.S. CLS. 23, 28 AND 44).  
LINDSEY RUBIN, EXAMINING ATTORNEY

SN 85-156,120. INGRAM, GARY E., DBA LOCKIT TOOLS, BELLINGHAM, WA. FILED 10-19-2010.



NO CLAIM IS MADE TO THE EXCLUSIVE RIGHT TO USE "SOCKET", APART FROM THE MARK AS SHOWN.

THE MARK CONSISTS OF AN INCOMPLETE SINGLE LINE OVAL WITH STAR OF TWELVE POINTS, THE OVAL BEING INTERRUPTED TO CONTAIN THE WORDS "LOCKIT SOCKET" AND THE STAR.

FOR HAND TOOLS, NAMELY, SPARK PLUG SOCKETS (U.S. CLS. 23, 28 AND 44).  
FIRST USE 7-13-1990; IN COMMERCE 7-13-1990.  
LEIGH CAROLINE CASE, EXAMINING ATTORNEY

SN 85-157,231. FLYNN ACQUISITIONS INC, WEST HILLS, CA. FILED 10-20-2010.



THE MARK CONSISTS OF STANDARD CHARACTERS WITHOUT CLAIM TO ANY PARTICULAR FONT, STYLE, SIZE, OR COLOR.

NO CLAIM IS MADE TO THE EXCLUSIVE RIGHT TO USE "SOCKET", APART FROM THE MARK AS SHOWN.

FOR HAND TOOLS, NAMELY, RATCHET WRENCHES; HAND TOOLS, NAMELY, SOCKET SETS; HAND TOOLS, NAMELY, SOCKET WRENCHES; HAND TOOLS, NAMELY, WRENCHES; NUT WRENCHES; SOCKET SPANNER; TORQUE WRENCHES (U.S. CLS. 23, 28 AND 44).  
FLORENTINA BLANDU, EXAMINING ATTORNEY

**CLASS 8—(Continued).**

SN 85-157,775. AW DISTRIBUTION COMPANY, LLC, BOONEVILLE, MS. FILED 10-21-2010.

# QUIC KLEAN

THE MARK CONSISTS OF STANDARD CHARACTERS WITHOUT CLAIM TO ANY PARTICULAR FONT, STYLE, SIZE, OR COLOR.

FOR HAND-OPERATED SHEARS; KNIVES FOR HUNTING, BUTCHERING, PAIRING, AND DEBONING; SCISSOR BLADES; SHEARS (U.S. CLS. 23, 28 AND 44).  
ALYSSA STEEL, EXAMINING ATTORNEY

**CLASS 8—(Continued).**

SN 85-178,114. INNOVATORS INC, CHICAGO, IL. FILED 11-16-2010.

# Just guide and slide out the other side

THE MARK CONSISTS OF STANDARD CHARACTERS WITHOUT CLAIM TO ANY PARTICULAR FONT, STYLE, SIZE, OR COLOR.

FOR HAND TOOLS, NAMELY, DEVICES USED TO RESTRING LACES AND DRAWSTRINGS (U.S. CLS. 23, 28 AND 44).  
FIRST USE 5-5-2010; IN COMMERCE 7-26-2010.  
CYNTHIA SLOAN, EXAMINING ATTORNEY

SN 85-165,808. BROTHER BRANDS, INC., WESTWOOD, NJ. FILED 11-1-2010.

# BUTCHER'S BEST

THE MARK CONSISTS OF STANDARD CHARACTERS WITHOUT CLAIM TO ANY PARTICULAR FONT, STYLE, SIZE, OR COLOR.

NO CLAIM IS MADE TO THE EXCLUSIVE RIGHT TO USE "BEST", APART FROM THE MARK AS SHOWN.  
FOR CUTLERY (U.S. CLS. 23, 28 AND 44).  
KHANH LE, EXAMINING ATTORNEY

SN 85-181,184. BOHLMAN, BARBARA, SHERMAN OAKS, CA. AND CARR, CAMILLE, SHERMAN OAKS, CA. FILED 11-19-2010.

# ROSEMATE

THE MARK CONSISTS OF STANDARD CHARACTERS WITHOUT CLAIM TO ANY PARTICULAR FONT, STYLE, SIZE, OR COLOR.

FOR HAND TOOL COMPRISING A FLOWER STEM SHEAR AND TRIMMER FOR REMOVING THORNS AND LEAVES FROM FLOWER STEMS (U.S. CLS. 23, 28 AND 44).  
FIRST USE 3-2-2007; IN COMMERCE 3-2-2007.  
PAM WILLIS, EXAMINING ATTORNEY

SN 85-178,098. INNOVATORS INC, CHICAGO, IL. FILED 11-16-2010.

# Don't Replace it, Relace it

THE MARK CONSISTS OF STANDARD CHARACTERS WITHOUT CLAIM TO ANY PARTICULAR FONT, STYLE, SIZE, OR COLOR.

FOR HAND TOOLS, NAMELY, DEVICES USED TO RESTRING LACES AND DRAWSTRINGS (U.S. CLS. 23, 28 AND 44).  
FIRST USE 5-5-2010; IN COMMERCE 7-26-2010.  
CYNTHIA SLOAN, EXAMINING ATTORNEY

SN 85-182,589. MENTOR GROUP, L.L.C., OREGON CITY, OR. FILED 11-22-2010.

# MANGUS

THE MARK CONSISTS OF STANDARD CHARACTERS WITHOUT CLAIM TO ANY PARTICULAR FONT, STYLE, SIZE, OR COLOR.

FOR FOLDING KNIVES (U.S. CLS. 23, 28 AND 44).  
LESLEY LAMOTHE, EXAMINING ATTORNEY

**CLASS 8—(Continued).**

SN 85-197,815. MENTOR GROUP, L.L.C., OREGON CITY, OR. FILED 12-14-2010.

**HARDTAIL**

THE MARK CONSISTS OF STANDARD CHARACTERS WITHOUT CLAIM TO ANY PARTICULAR FONT, STYLE, SIZE, OR COLOR.

FOR FOLDING KNIVES (U.S. CLS. 23, 28 AND 44).  
FIRST USE 3-4-2008; IN COMMERCE 3-4-2008.  
LESLEY LAMOTHE, EXAMINING ATTORNEY

SN 85-197,819. MENTOR GROUP, L.L.C., OREGON CITY, OR. FILED 12-14-2010.

**NIGHTSHIFT**

THE MARK CONSISTS OF STANDARD CHARACTERS WITHOUT CLAIM TO ANY PARTICULAR FONT, STYLE, SIZE, OR COLOR.

FOR FOLDING KNIVES (U.S. CLS. 23, 28 AND 44).  
FIRST USE 2-26-2008; IN COMMERCE 2-26-2008.  
LESLEY LAMOTHE, EXAMINING ATTORNEY

**CLASS 9—ELECTRICAL AND SCIENTIFIC APPARATUS**

SN 76-701,144. PRODUCT CLUB CORP, ROCKAWAY, NJ. FILED 1-11-2010.

**JETBLACK**

THE MARK CONSISTS OF STANDARD CHARACTERS WITHOUT CLAIM TO ANY PARTICULAR FONT, STYLE, SIZE, OR COLOR.

SEC. 2(F).  
FOR PROTECTIVE GLOVES FOR INDUSTRIAL USE (U.S. CLS. 21, 23, 26, 36 AND 38).  
FIRST USE 4-0-2004; IN COMMERCE 4-0-2004.  
ROBERT C. CLARK JR., EXAMINING ATTORNEY

**CLASS 9—(Continued).**

SN 76-703,057. COLONIAL RADIO THEATRE ON THE AIR, ROUND ROCK, TX. FILED 5-21-2010.



NO CLAIM IS MADE TO THE EXCLUSIVE RIGHT TO USE "AUDIO", APART FROM THE MARK AS SHOWN.

THE MARK CONSISTS OF THE STYLIZED DESIGN OF A WINGED WYVERN (A MYTHICAL HERALDIC DRAGON) FORMING A CIRCLE THAT CONNECTS ABOVE A SEMI-RECTANGLE CONTAINING THE WORDING "WYVERN" OVER "AUDIO".

FOR AUDIO RECORDINGS OF VERBAL MATERIALS, NAMELY, PRERECORDED MEDIA CONTAINING DRAMATIZATIONS, READINGS AND RECITATIONS OF RADIO THEATRE, SHORT STORIES, BOOKS, POETRY AND SPEECHES (U.S. CLS. 21, 23, 26, 36 AND 38).  
ANN E. SAPPENFIELD, EXAMINING ATTORNEY

SN 76-703,064. GB INVEST LLC, KANKAKEE, IL. FILED 5-21-2010.

**Health Touch**

THE MARK CONSISTS OF STANDARD CHARACTERS WITHOUT CLAIM TO ANY PARTICULAR FONT, STYLE, SIZE, OR COLOR.

NO CLAIM IS MADE TO THE EXCLUSIVE RIGHT TO USE "HEALTH", APART FROM THE MARK AS SHOWN.

FOR VOICE-BASED, REAL-TIME, PHYSICIAN ORDER ENTRY SYSTEM CONSISTING OF PROPRIETARY SOFTWARE AND HARDWARE, AN ALL-IN-ONE ELECTRONIC COMPUTERIZED PHYSICIAN ORDER ENTRY MEDICAL RECORDS PRODUCT FOR USE IN PHYSICIAN EXAM ROOMS AND NURSING STATIONS (U.S. CLS. 21, 23, 26, 36 AND 38).

FIRST USE 1-1-2010; IN COMMERCE 1-1-2010.

ANN E. SAPPENFIELD, EXAMINING ATTORNEY



**CLASS 9—(Continued).**

SN 76-704,329. PARKER, ROBERT LEE, UPPER MARLBORO, MD. FILED 9-1-2010.

**BLUESNIGHT RECORDS**

THE MARK CONSISTS OF STANDARD CHARACTERS WITHOUT CLAIM TO ANY PARTICULAR FONT, STYLE, SIZE, OR COLOR.

NO CLAIM IS MADE TO THE EXCLUSIVE RIGHT TO USE "RECORDS", APART FROM THE MARK AS SHOWN. FOR PRERECORDED MUSICAL RECORDINGS IN NATURE OF CD'S DVD'S, VIDEO'S (U.S. CLS. 21, 23, 26, 36 AND 38).

CAROLYN CATALDO, EXAMINING ATTORNEY

**CLASS 9—(Continued).**

SN 77-593,963. STAMPIN' UP!, INC., ST. GEORGE, UT. FILED 10-16-2008.

**My Digital Studio**

THE MARK CONSISTS OF STANDARD CHARACTERS WITHOUT CLAIM TO ANY PARTICULAR FONT, STYLE, SIZE, OR COLOR.

NO CLAIM IS MADE TO THE EXCLUSIVE RIGHT TO USE "DIGITAL", APART FROM THE MARK AS SHOWN.

FOR COMPUTER SOFTWARE FOR USE IN THE CREATION OF SCRAPBOOKS AND CALENDARS INCORPORATING IMAGES AND DESIGNS DOWNLOADED FROM THE INTERNET (U.S. CLS. 21, 23, 26, 36 AND 38).

ROBERT STRUCK, EXAMINING ATTORNEY

SN 77-068,551. SHELTERED WINGS, INC., MIDDLETOWN, WI. FILED 12-20-2006.

**DIAMONDBACK**

THE MARK CONSISTS OF STANDARD CHARACTERS WITHOUT CLAIM TO ANY PARTICULAR FONT, STYLE, SIZE, OR COLOR.

OWNER OF U.S. REG. NO. 3,809,046. FOR BINOCULARS FOR SPORTING USE (U.S. CLS. 21, 23, 26, 36 AND 38).

FIRST USE 3-31-2006; IN COMMERCE 11-30-2006.

MARC LEIPZIG, EXAMINING ATTORNEY

SN 77-314,939. MITCHELL, NAM DANG, CALGARY, CANADA, FILED 10-26-2007.

**ECOHOME**

THE MARK CONSISTS OF STANDARD CHARACTERS WITHOUT CLAIM TO ANY PARTICULAR FONT, STYLE, SIZE, OR COLOR.

PRIORITY CLAIMED UNDER SEC. 44(D) ON CANADA APPLICATION NO. 1345723, FILED 5-1-2007, REG. NO. TMA783829, DATED 12-1-2010, EXPIRES 12-1-2025.

FOR HOME AND OFFICE AUTOMATION SYSTEMS COMPRISING WIRELESS AND WIRED CONTROLLERS, CONTROLLED DEVICES, AND SOFTWARE FOR LIGHTING AND OTHER HOME AND OFFICE MONITORING AND CONTROL APPLICATIONS; RECHARGEABLE BATTERIES; ELECTRONIC LIGHTING TIMERS; PROGRAMMABLE THERMOSTATS; HOME AUTOMATION CONTROLS, NAMELY, WIRELESS REMOTE CONTROLS FOR LIGHTS AND DOORBELLS; ELECTRICAL DOOR BELLS; ACCESS CONTROL AND ALARM MONITORING SYSTEMS; ELECTRIC METERS, NAMELY, ELECTRICAL ENERGY METERS; ELECTRICAL OUTDOOR TIMERS FOR TIMING WHEN LIGHTS COME ON AT NIGHT; REMOTE ELECTRONIC TEMPERATURE AND HUMIDITY SENSOR WITH LCD DISPLAY INCORPORATING A CLOCK WITH ALARM AND CALENDAR FEATURES (U.S. CLS. 21, 23, 26, 36 AND 38).

JAY BESCH, EXAMINING ATTORNEY

SN 77-627,453. ULTIMATE RISK SOLUTIONS, LLC, OWINGS MILLS, MD. FILED 12-5-2008.

**URS REAL WORLD**

THE MARK CONSISTS OF STANDARD CHARACTERS WITHOUT CLAIM TO ANY PARTICULAR FONT, STYLE, SIZE, OR COLOR.

OWNER OF U.S. REG. NO. 2,855,341. FOR COMPUTER SOFTWARE FOR MATHEMATICAL AND STATISTICAL MODELING OF THE GLOBAL ECONOMY (U.S. CLS. 21, 23, 26, 36 AND 38).

TARA PATE, EXAMINING ATTORNEY

**CLASS 9—(Continued).**

SN 77-683,793. HAANSOFT INC., SEOUL, REPUBLIC OF KOREA, FILED 3-4-2009.

thinkfree docs

THE MARK CONSISTS OF STANDARD CHARACTERS WITHOUT CLAIM TO ANY PARTICULAR FONT, STYLE, SIZE, OR COLOR.

PRIORITY CLAIMED UNDER SEC. 44(D) ON REPUBLIC OF KOREA APPLICATION NO. 2009-0009073, FILED 2-27-2009, REG. NO. 40-0823757, DATED 5-19-2010, EXPIRES 5-19-2020.

OWNER OF U.S. REG. NOS. 2,449,947 AND 2,451,900.

NO CLAIM IS MADE TO THE EXCLUSIVE RIGHT TO USE "DOCS", APART FROM THE MARK AS SHOWN.

FOR DOWNLOADABLE MUSIC VIA THE INTERNET AND WIRELESS DEVICES; PRE-RECORDED ELECTRONIC MEDIA FEATURING COMPUTER PROGRAM FOR DOCUMENT MANAGEMENT; PRE-RECORDED CDS FEATURING COMPUTER SOFTWARE FOR DOCUMENT MANAGEMENT; PRE-RECORDED DVDS FEATURING COMPUTER SOFTWARE FOR DOCUMENT MANAGEMENT; DOWNLOADABLE ELECTRONIC PUBLICATIONS IN THE NATURE OF BOOKS IN THE FIELD OF COMPUTER SOFTWARE; ELECTRONIC BOOKS FEATURING COMPUTER SOFTWARE RECORDED ON COMPUTER MEDIA; DOWNLOADABLE ELECTRONIC NEWSPAPERS IN THE FIELD OF COMPUTER SOFTWARE; ELECTRONIC TEXTBOOKS AND STUDY AIDS IN THE FIELD OF COMPUTER SOFTWARE; VIRTUAL REALITY GAME SOFTWARE; BLANK OPTICAL DISCS; SOFTWARE FOR OPTICAL CHARACTER RECOGNITION; COMPUTER PROGRAMS FOR PRE-RECORDED GAMES; COMPUTER SOFTWARE FOR WORD PROCESSING; COMPUTER SOFTWARE FOR DATABASE MANAGEMENT; COMPUTER SOFTWARE FOR SPREADSHEETS; COMPUTER SOFTWARE FOR DESKTOP ORGANIZATION; COMPUTER SOFTWARE FOR E-MAIL; COMPUTER SOFTWARE FOR CALENDARING AND SCHEDULING; COMPUTER OPERATING PROGRAMS; COMPUTER PROGRAMS FOR DOCUMENT MANAGEMENT; MICROPROCESSORS; COMPUTER SOFTWARE FOR ENCRYPTION; OPERATING SYSTEM PROGRAMS; WORD PROCESSORS; COMPUTER APPLICATION SOFTWARE FOR MOBILE PHONES; SOFTWARE FOR ENSURING THE SECURITY OF ELECTRONIC MAIL; ELECTRONIC AGENDAS; COMPUTER PROGRAMS FOR THE ENABLING OF ACCESS OR ENTRANCE CONTROL; CENTRAL PROCESSING UNITS; CHIP CARDS; COMPUTERS; COMPUTER GAME PROGRAMS; COMPUTER MEMORIES; COMPUTER PERIPHERAL DEVICES; CD-ROM DRIVES; INTEGRATED CIRCUIT CARDS (U.S. CLS. 21, 23, 26, 36 AND 38).

Laura KOVALSKY, EXAMINING ATTORNEY

**CLASS 9—(Continued).**

SN 77-696,061. BINDER GMBH, DBA BINDER GMBH, TUTTLINGEN, FED REP GERMANY, FILED 3-20-2009.

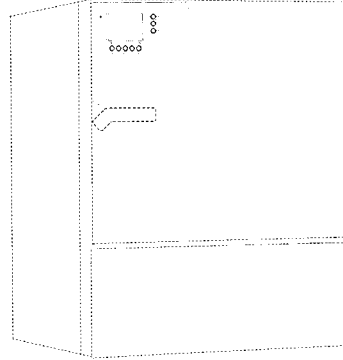

NO CLAIM IS MADE TO THE EXCLUSIVE RIGHT TO USE THE SHAPE OF THE ROUND BUTTONS AND THE RECTANGULAR DISPLAY SCREEN, APART FROM THE MARK AS SHOWN.

THE MARK CONSISTS OF A TRIANGULAR THREE DIMENSIONAL CONFIGURATION OF AN ADDITIONAL PART OF THE GOODS APPEARING IN THE UPPER-LEFT CORNER OF THE FRONT DOOR OF SAID GOODS, WITH A RECTANGULAR DISPLAY IN THE MIDDLE OF ITS SURFACE, WITH A HORIZONTALLY ALIGNED OVAL UNDERNEATH THE DISPLAY, THAT CONTAINS FIVE ROUND BUTTONS, A SECOND VERTICALLY ALIGNED OVAL ON THE RIGHT SIDE OF THE DISPLAY, CONTAINING THREE ROUND BUTTONS, AND ONE ROUND BUTTON LOCATED ON THE LEFT SIDE OF THE DISPLAY. MATTER SHOWN IN BROKEN LINES IS NOT CLAIMED AS A FEATURE OF THE MARK, AND SERVES ONLY TO SHOW THE PLACEMENT OF THE MARK.

SEC. 2(F).

FOR LABORATORY APPARATUS AND INSTRUMENTS, NAMELY, INCUBATORS, TEMPERATURE CHAMBERS, CLIMATIC CHAMBERS, TEST CHAMBERS, HEATING CHAMBERS, GROWTH CHAMBERS, DRYING OVENS AND HOT-AIR STERILIZERS (U.S. CLS. 21, 23, 26, 36 AND 38).

FIRST USE 12-31-2002; IN COMMERCE 12-31-2002.

MARC LEIPZIG, EXAMINING ATTORNEY

SN 77-696,068. BINDER GMBH, DBA BINDER GMBH, TUTTLINGEN, FED REP GERMANY, FILED 3-20-2009.

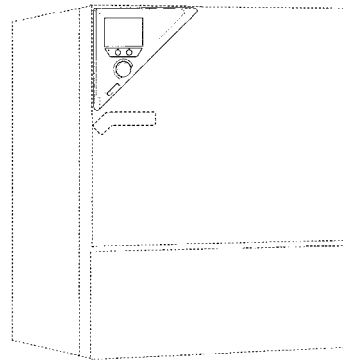

NO CLAIM IS MADE TO THE EXCLUSIVE RIGHT TO USE THE SHAPE OF THE ROUND KNOBS AND BUTTONS AND THE RECTANGULAR DISPLAY SCREEN, APART FROM THE MARK AS SHOWN.

THE MARK CONSISTS OF A TRIANGULAR THREE DIMENSIONAL CONFIGURATION OF AN ADDITIONAL

**CLASS 9—(Continued).**

PART OF THE GOODS APPEARING IN THE UPPER-LEFT CORNER OF THE FRONT DOOR OF SAID GOODS, WITH A RECTANGULAR DISPLAY IN THE MIDDLE OF ITS SURFACE, WITH A TRAPEZOID SHAPE UNDERNEATH THE DISPLAY THAT CONTAINS TWO HORIZONTALLY ALIGNED ROUND BUTTONS, A LARGE ROUND BUTTON UNDERNEATH THE TRAPEZOID SHAPE, AND A SWITCH ON THE LOWER THIRD OF THE SIDE OPPOSITE TO THE RIGHT ANGLE. MATTER SHOWN IN BROKEN LINES IS NOT CLAIMED AS A FEATURE OF THE MARK, AND SERVES ONLY TO SHOW THE PLACEMENT OF THE MARK.

SEC. 2(F).  
 FOR LABORATORY APPARATUS AND INSTRUMENTS, NAMELY, INCUBATORS, TEMPERATURE CHAMBERS, CLIMATIC CHAMBERS, TEST CHAMBERS, HEATING CHAMBERS, GROWTH CHAMBERS, DRYING OVENS AND HOT-AIR STERILIZERS (U.S. CLS. 21, 23, 26, 36 AND 38).  
 MARC LEIPZIG, EXAMINING ATTORNEY

**CLASS 9—(Continued).**

SN 77-697,928. BINDER GMBH, DBA BINDER GMBH, TUTTLINGEN, FED REP GERMANY, FILED 3-24-2009.

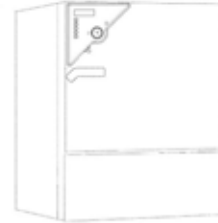

NO CLAIM IS MADE TO THE EXCLUSIVE RIGHT TO USE THE SHAPE OF THE ROUND KNOBS AND BUTTONS AND THE RECTANGULAR DISPLAY SCREEN, APART FROM THE MARK AS SHOWN.

THE MARK CONSISTS OF A TRIANGULAR THREE DIMENSIONAL CONFIGURATION OF AN ADDITIONAL PART OF THE GOODS APPEARING IN THE UPPER-LEFT CORNER OF THE FRONT DOOR OF SAID GOODS, WITH A RECTANGULAR DISPLAY IN THE TOP LEFT CORNER OF THE SURFACE WITH FIVE VERTICALLY ALIGNED ROUND BUTTONS UNDERNEATH THE DISPLAY, A LARGE BUTTON IN THE MIDDLE OF THE SIDE OPPOSITE TO THE RIGHT ANGLE, CREATING AN OUTWARD BULGE IN THIS SIDE, AND A SWITCH BETWEEN THE LARGE BUTTON AND THE BOTTOM LEFT CORNER OF THE SURFACE, AND A PILOT LAMP BETWEEN THE LARGE BUTTON AND THE TOP RIGHT CORNER OF THE SURFACE. MATTER SHOWN IN BROKEN LINES IS NOT CLAIMED AS A FEATURE OF THE MARK, AND SERVES ONLY TO SHOW THE PLACEMENT OF THE MARK.

SEC. 2(F).  
 FOR LABORATORY APPARATUS AND INSTRUMENTS, NAMELY, INCUBATORS, TEMPERATURE CHAMBERS, HEATING CHAMBERS, DRYING OVENS AND HOT-AIR STERILIZERS (U.S. CLS. 21, 23, 26, 36 AND 38).  
 FIRST USE 12-31-2000; IN COMMERCE 12-31-2000.  
 MARC LEIPZIG, EXAMINING ATTORNEY

SN 77-696,071. BINDER GMBH, DBA BINDER GMBH, TUTTLINGEN, FED REP GERMANY, FILED 3-20-2009.

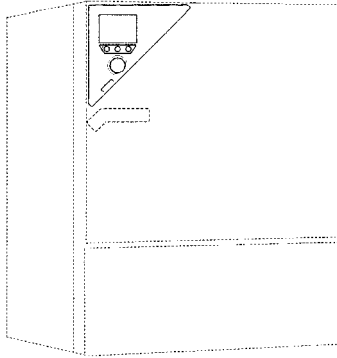

NO CLAIM IS MADE TO THE EXCLUSIVE RIGHT TO USE THE SHAPE OF THE ROUND KNOBS AND BUTTONS AND THE RECTANGULAR DISPLAY SCREEN, APART FROM THE MARK AS SHOWN.

THE MARK CONSISTS OF A TRIANGULAR THREE DIMENSIONAL CONFIGURATION OF AN ADDITIONAL PART OF THE GOODS APPEARING IN THE UPPER-LEFT CORNER OF THE FRONT DOOR OF SAID GOODS, WITH A RECTANGULAR DISPLAY IN THE MIDDLE OF ITS SURFACE, WITH A TRAPEZOID SHAPE UNDERNEATH THE DISPLAY THAT CONTAINS THREE HORIZONTALLY ALIGNED ROUND BUTTONS, A LARGE ROUND BUTTON UNDERNEATH THE TRAPEZOID SHAPE, AND A SWITCH ON THE LOWER THIRD OF THE SIDE OPPOSITE TO THE RIGHT ANGLE. MATTER SHOWN IN BROKEN LINES IS NOT CLAIMED AS A FEATURE OF THE MARK, AND SERVES ONLY TO SHOW THE PLACEMENT OF THE MARK.

SEC. 2(F).  
 FOR LABORATORY APPARATUS AND INSTRUMENTS, NAMELY, INCUBATORS, TEMPERATURE CHAMBERS, CLIMATIC CHAMBERS, TEST CHAMBERS, HEATING CHAMBERS, GROWTH CHAMBERS, DRYING OVENS AND HOT-AIR STERILIZERS (U.S. CLS. 21, 23, 26, 36 AND 38).  
 MARC LEIPZIG, EXAMINING ATTORNEY

SN 77-699,960. PHYTOTRONICS, INC., EARTH CITY, MO. FILED 3-26-2009.

**PHYTO-LITE**

THE MARK CONSISTS OF THE STYLIZED WORD "PHYTO-LITE" WITHOUT ANY COLOR.

FOR ELECTRIC FLUORESCENT PROPAGATION LIGHT LAMP BALLASTS (U.S. CLS. 21, 23, 26, 36 AND 38).  
 FIRST USE 6-10-1980; IN COMMERCE 6-10-1980.  
 YAT SYE, LEE, EXAMINING ATTORNEY

**CLASS 9—(Continued).**

SN 77-700,950. MOMQUIST, DAVID, TULSA, OK. FILED 3-27-2009.

**TOW TEAM WARNING SYSTEM:  
TTWS**

THE MARK CONSISTS OF STANDARD CHARACTERS WITHOUT CLAIM TO ANY PARTICULAR FONT, STYLE, SIZE, OR COLOR.

NO CLAIM IS MADE TO THE EXCLUSIVE RIGHT TO USE "WARNING SYSTEM", APART FROM THE MARK AS SHOWN.

FOR AUTOMOTIVE, INDUSTRIAL, CONSTRUCTION, LOCOMOTIVE, AVIATION, NAVIGATION AND MARINE SAFETY-WARNING LIGHTS, NAMELY, STROBES, ROTATING LIGHTS AND BAR LIGHTS; ELECTRIC WARNING LIGHT SYSTEMS; ELECTRIC WARNING LIGHTS; ELECTRONIC WARNING BELLS; ELECTRONIC WARNING HORN; EMERGENCY WARNING LIGHTS; LUMINOUS BEACONS FOR SAFETY OR WARNING PURPOSES; WARNING DEVICES, NAMELY, BELLS (U.S. CLS. 21, 23, 26, 36 AND 38).

ROSELLE HERRERA, EXAMINING ATTORNEY

SN 77-706,444. KRAMER ELECTRONICS LTD, JERUSALEM, ISRAEL, FILED 4-3-2009.

**MEGATOOLS**

THE MARK CONSISTS OF STANDARD CHARACTERS WITHOUT CLAIM TO ANY PARTICULAR FONT, STYLE, SIZE, OR COLOR.

PRIORITY CLAIMED UNDER SEC. 44(D) ON ISRAEL APPLICATION NO. 216166, FILED 10-28-2008, REG. NO. 216166, DATED 10-28-2008, EXPIRES 10-28-2018.

FOR APPARATUS AND INSTRUMENTS FOR VIEWING, RECORDING, TRANSMISSION, PROCESSING AND REPRODUCTION OF DIGITAL OR ANALOG, SOUND OR IMAGES, NAMELY, VIDEO-AUDIO SIGNAL DISTRIBUTORS, VIDEO-AUDIO SIGNAL SWITCHERS AND MATRIX SWITCHERS, VIDEO-AUDIO ENHANCERS, PROCESSORS, RF PROCESSORS, SPECIAL EFFECTS GENERATORS, VIDEO ENCODERS AND DECODERS, ELECTRONIC VIDEO SIGNAL SCALERS AND SCAN CONVERTERS, VIDEO STANDARD CONVERTERS, VIDEO TIME BASE CORRECTORS, COMPUTER GUNLOCK EQUIPMENT, NAMELY, GUNLOCK SYSTEMS FOR GRAPHICS AND TEXT OVERLAY, COMPUTER CONTROLLED VIDEO EQUIPMENT, NAMELY, VIDEO MATRIX AND PROCESSING CONTROL PANELS, COMPUTER INTERFACE PRODUCTS, NAMELY, TTL (TRANSISTOR-TRANSISTOR LOGIC) ANALOGUE ENCODERS, TTL (TRANSISTOR-TRANSISTOR LOGIC) TO ANALOGUE CONVERTERS, TTL (TRANSISTOR-TRANSISTOR LOGIC) GENLOCK ENCODER CARDS, ROOM CONTROL DEVICES, NAMELY, WALL PLATES AND TABLE BUSES WITH INFRARED, ETHERNET, WI-FI AND RS-232 CONTROLLING DEVICES, AUDIO SIGNAL DEFECT CORRECTORS, VIDEO LINE AMPLIFIERS, TWISTED PAIR SIGNAL TRANSMITTERS AND RECEIVERS, VIDEO SCREEN SPLITTERS AND VIDEO TIME BASE SIGNAL DELAY CORRECTORS, BLANK MAGNETIC DATA CARRIERS; BLANK RECORDING DISCS; COMPUTER SOFTWARE AND PROGRAMS FOR USE WITH THE AFOREMENTIONED PRODUCTS (U.S. CLS. 21, 23, 26, 36 AND 38).

TARAH HARDY, EXAMINING ATTORNEY

**CLASS 9—(Continued).**

SN 77-730,406. CELLCO PARTNERSHIP, DBA VERIZON WIRELESS, BASKING RIDGE, NJ. FILED 5-6-2009.

**V CAST**

THE MARK CONSISTS OF STANDARD CHARACTERS WITHOUT CLAIM TO ANY PARTICULAR FONT, STYLE, SIZE, OR COLOR.

OWNER OF U.S. REG. NOS. 2,788,266 AND 3,377,283. FOR DOWNLOADABLE SOFTWARE FOR THE TRANSFERRING, UPLOADING, EDITING, LOCATING, ORGANIZING AND MANAGING OF MEDIA AND DIGITAL FILES (U.S. CLS. 21, 23, 26, 36 AND 38).

FIRST USE 12-14-2009; IN COMMERCE 12-14-2009.

JOHN SCHUYLER YARD, EXAMINING ATTORNEY

SN 77-752,017. LG ELECTRONICS INC., SEOUL, REPUBLIC OF KOREA, FILED 6-4-2009.

**BLISS**

THE MARK CONSISTS OF STANDARD CHARACTERS WITHOUT CLAIM TO ANY PARTICULAR FONT, STYLE, SIZE, OR COLOR.

FOR MOBILE PHONES; TELEVISION RECEIVERS (U.S. CLS. 21, 23, 26, 36 AND 38).

JASON BLAIR, EXAMINING ATTORNEY

SN 77-755,382. SFE GESELLSCHAFT FUER STRUKTURANALYSE MBH, BERLIN, FED REP GERMANY, FILED 6-9-2009.

**SFE CONCEPT**

THE MARK CONSISTS OF STANDARD CHARACTERS WITHOUT CLAIM TO ANY PARTICULAR FONT, STYLE, SIZE, OR COLOR.

OWNER OF FED REP GERMANY REG. NO. 30033419, DATED 5-2-2000, RENEWED AS REG. NO. 30033419, DATED 4-29-2010, EXPIRES 5-31-2020.

NO CLAIM IS MADE TO THE EXCLUSIVE RIGHT TO USE "CONCEPT", APART FROM THE MARK AS SHOWN.

FOR COMPUTER SOFTWARE IN THE FIELD OF DESIGN AND ENGINEERING, SPECIFICALLY FOR DETERMINING THE MECHANICAL BEHAVIOR OF RAIL - AND ROAD VEHICLES, NAMELY, TOPOLOGY BASED SOFTWARE FOR MODELING COMPLEX GEOMETRIES BY USING ABSTRACT ELEMENTS TO AUTOMATICALLY GENERATE A DISTINCT DESCRIPTION OF THE TOPOLOGY AND GEOMETRY OF STRUCTURES (U.S. CLS. 21, 23, 26, 36 AND 38).

FIRST USE 1-31-1997; IN COMMERCE 1-31-1997.

JENNY PARK, EXAMINING ATTORNEY

**CLASS 9—(Continued).**

SN 77-764,176. LS CABLE LTD., ANYANG-SI, GYEONGGI-DO, REPUBLIC OF KOREA, FILED 6-19-2009.

**CLASS 9—(Continued).**

SN 77-839,120. LG ELECTRONICS INC., SEOUL, REPUBLIC OF KOREA, FILED 10-1-2009.

# WindSol

THE MARK CONSISTS OF STANDARD CHARACTERS WITHOUT CLAIM TO ANY PARTICULAR FONT, STYLE, SIZE, OR COLOR.

OWNER OF REPUBLIC OF KOREA REG. NO. 0832240, DATED 8-6-2010, EXPIRES 8-6-2020.

FOR OPTICAL FIBERS; OPTIC FIBER CABLES; ELECTRIC CABLES; TELECOMMUNICATION CABLES; ELECTRIC WIRES; POWER CABLES; COAXIAL CABLES; CABLES FOR ELECTRICAL OR OPTICAL SIGNAL TRANSMISSION (U.S. CLS. 21, 23, 26, 36 AND 38).

KAREN BRACEY, EXAMINING ATTORNEY



OWNER OF ERPN CMNTY TM OFC REG. NO. 008588113, DATED 3-29-2010, EXPIRES 1-10-2019.

NO CLAIM IS MADE TO THE EXCLUSIVE RIGHT TO USE "AUTO POWER SAVE", APART FROM THE MARK AS SHOWN.

THE MARK CONSISTS OF THE WORDS "AUTO POWER SAVE" WITH THE ACRONYM "APS" BENEATH IT. TO THE RIGHT OF "APS" IS A DESIGN OF TWO LEAVES.

FOR TELEPHONE SETS; WIRELESS TELEPHONE SETS; PORTABLE COMMUNICATIONS APPARATUS, NAMELY, HANDSETS, WALKIE-TALKIES, SATELLITE TELEPHONES AND PERSONAL DIGITAL ASSISTANTS; MOBILE PHONES; MPEG AUDIO LAYER-3 PLAYERS; TELEVISION RECEIVERS; TELEVISION REMOTE CONTROLLERS; UNIVERSAL SERIAL BUSDRIVES; DIGITAL MEDIA BROADCASTING PLAYERS; HEADSETS FOR MOBILE PHONES; PORTABLE CHARGERS FOR BATTERIES; ELECTRONIC ALBUMS, NAMELY, ELECTRONIC PHOTO ALBUMS; DIGITAL PICTURE FRAMES FOR DISPLAYING DIGITAL PICTURES; MONITORS FOR COMPUTER; LAPTOP COMPUTERS; COMPUTERS; DIGITAL VERSATILE DISC PLAYER; PORTABLE HARD DISK DRIVES; APPARATUS FOR RECORDING, TRANSMISSION OR REPRODUCTION OF SOUND OR IMAGES FOR USE IN TELECOMMUNICATION; APPARATUS FOR RECORDING, TRANSMISSION OR REPRODUCTION OF SOUND OR IMAGES; COMPUTER APPLICATION SOFTWARE FOR IMPROVEMENT OF MOBILE PHONES IMAGE QUALITY; DIGITAL VERSATILE DISC PLAYERS FOR HOME THEATERS; SPEAKERS FOR HOME THEATERS; AUDIO-VIDEO RECEIVERS FOR HOME THEATERS; PROJECTORS FOR HOME THEATERS; INTEGRATED CIRCUITS; AUDIO RECEIVERS; ON BOARD UNITS AND ELECTRONIC TOLL SMART CARDS FOR EXPEDITED PASS THROUGH HIGHWAY TOLL FACILITIES; TRANSPONDERS, NAMELY, ELECTRONIC TERMINALS EQUIPPED IN VEHICLES FOR TOLL PAYMENT TRANSACTIONS; CLOSED-CIRCUIT TELEVISION CAMERAS; NETWORK MONITORING CAMERAS, NAMELY, FOR SURVEILLANCE (U.S. CLS. 21, 23, 26, 36 AND 38).

ADA HAN, EXAMINING ATTORNEY

SN 77-831,183. EGAN VISUAL INC., WOODBRIDGE, CANADA, FILED 9-21-2009.

# EGAN VERSABOARD

THE MARK CONSISTS OF STANDARD CHARACTERS WITHOUT CLAIM TO ANY PARTICULAR FONT, STYLE, SIZE, OR COLOR.

FOR PROJECTION SCREENS; FLEXIBLE AND MOUNTABLE PROJECTION SCREENS; FLEXIBLE AND MOUNTABLE PROJECTION SCREEN; PROJECTION SCREENS WITH A SURFACE THAT CAN BE WRITTEN ON AND ERASED; FLEXIBLE AND MOUNTABLE PROJECTION SCREENS THAT CAN BE WRITTEN ON AND ERASED (U.S. CLS. 21, 23, 26, 36 AND 38).

FIRST USE 12-31-2004; IN COMMERCE 12-31-2004.  
MEGHAN REINHART, EXAMINING ATTORNEY

**CLASS 9—(Continued).**

SN 77-839,132. LG ELECTRONICS INC., SEOUL, REPUBLIC OF KOREA, FILED 10-1-2009.



OWNER OF ERPN CMNTY TM OFC REG. NO. 008588212, DATED 3-29-2010, EXPIRES 10-1-2019.

NO CLAIM IS MADE TO THE EXCLUSIVE RIGHT TO USE "WIRELESS AV LINK", APART FROM THE MARK AS SHOWN.

THE MARK CONSISTS OF THE WORD "WIRELESS" LOWER CASE LETTERS WITH A SERIES OF FOUR CONCENTRIC ARCED LINES ABOVE THE DOT IN THE LETTER "I", SUCH CONCENTRIC LINES BEING OF A GRAY SHADE ON THEIR LEFT SIDE AND BLACK ON THEIR RIGHT SIDE, AND THE WORD "WIRELESS" FURTHER HAVING A RECTANGULAR BLACK BOX BELOW THE "LESS" PORTION OF THE MARK IN WHICH THE TERM "AV LINK" IS ENCLOSED.

FOR TELEVISION SETS; WIRELESS TELEPHONE SETS; PORTABLE COMMUNICATIONS APPARATUS, NAMELY, HANDSETS, WALKI-TALKIES, SATELLITE TELEPHONES AND PERSONAL DIGITAL ASSISTANTS; MOBILE PHONES; MPEG AUDIO LAYER-3 PLAYERS; TELEVISION RECEIVERS; TELEVISION REMOTE CONTROLLERS; UNIVERSAL SERIAL BUS DRIVES; DIGITAL MEDIA BROADCASTING PLAYERS; HEADSETS FOR MOBILE PHONES; PORTABLE CHARGERS FOR BATTERIES; ELECTRONIC ALBUMS, NAMELY, ELECTRONIC PHOTO ALBUMS; DIGITAL PICTURE FRAMES FOR DISPLAYING DIGITAL PICTURES; MONITORS FOR COMPUTER; LAPTOP COMPUTERS; COMPUTERS; DIGITAL VERSATILE DISC PLAYERS; PORTABLE HARD DISK DRIVES; APPARATUS FOR RECORDING, TRANSMISSION OR REPRODUCTION OF SOUND OR IMAGES FOR USE IN TELECOMMUNICATION; APPARATUS FOR RECORDING, TRANSMISSION OR REPRODUCTION OF SOUND OR IMAGES; COMPUTER APPLICATION SOFTWARE FOR IMPROVEMENT OF MOBILE PHONES IMAGE QUALITY; DIGITAL VERSATILE DISC PLAYERS FOR HOME THEATERS; SPEAKERS FOR HOME THEATERS; AUDIO-VIDEO RECEIVERS FOR HOME THEATERS; PROJECTORS FOR HOME THEATERS; INTEGRATED CIRCUITS; AUDIO RECEIVERS; ON BOARD UNITS AND ELECTRONIC TOLL SMART CARDS FOR EXPEDITED PASS THROUGH HIGHWAY TOLL FACILITIES; TRANSPONDERS, NAMELY, ELECTRONIC TERMINALS EQUIPPED IN VEHICLES FOR TOLL PAYMENT TRANSACTIONS; CLOSED-CIRCUIT TELEVISION CAMERAS; NETWORK MONITORING CAMERAS, NAMELY, FOR SURVEILLANCE (U.S. CLS. 21, 23, 26, 36 AND 38).

ADA HAN, EXAMINING ATTORNEY

**CLASS 9—(Continued).**

SN 77-842,351. LG ELECTRONICS INC., SEOUL, REPUBLIC OF KOREA, FILED 10-6-2009.

**WIDER THE BETTER**

THE MARK CONSISTS OF STANDARD CHARACTERS WITHOUT CLAIM TO ANY PARTICULAR FONT, STYLE, SIZE, OR COLOR.

OWNER OF ERPN CMNTY TM OFC REG. NO. 008599268, DATED 5-10-2010, EXPIRES 10-7-2019.

FOR TELEVISION SETS; WIRELESS TELEPHONE SETS; PORTABLE COMMUNICATIONS APPARATUS, NAMELY, HANDSETS, WALKI-TALKIES, SATELLITE TELEPHONES AND PERSONAL DIGITAL ASSISTANTS; MOBILE PHONES; MPEG AUDIO LAYER-3 PLAYERS; TELEVISION RECEIVERS; TELEVISION REMOTE CONTROLLERS; UNIVERSAL SERIAL BUS DRIVES; DIGITAL MEDIA BROADCASTING PLAYERS; HEADSETS FOR MOBILE PHONES; PORTABLE CHARGERS FOR BATTERIES; ELECTRONIC ALBUMS, NAMELY, ELECTRONIC PHOTO ALBUMS; DIGITAL PICTURE FRAMES FOR DISPLAYING DIGITAL PICTURES; MONITORS FOR COMPUTER; LAPTOP COMPUTERS; COMPUTERS; DIGITAL VERSATILE DISC PLAYERS; PORTABLE HARD DISK DRIVES; APPARATUS FOR RECORDING, TRANSMISSION OR REPRODUCTION OF SOUND OR IMAGES FOR USE IN TELECOMMUNICATION; APPARATUS FOR RECORDING, TRANSMISSION OR REPRODUCTION OF SOUND OR IMAGES; COMPUTER APPLICATION SOFTWARE FOR IMPROVEMENT OF MOBILE PHONES IMAGE QUALITY; DIGITAL VERSATILE DISC PLAYERS FOR HOME THEATERS; SPEAKERS FOR HOME THEATERS; AUDIO-VIDEO RECEIVERS FOR HOME THEATERS; PROJECTORS FOR HOME THEATERS; INTEGRATED CIRCUITS; AUDIO RECEIVERS; ON BOARD UNITS AND ELECTRONIC TOLL SMART CARDS FOR EXPEDITED PASS THROUGH HIGHWAY TOLL FACILITIES; TRANSPONDERS, NAMELY, ELECTRONIC TERMINALS EQUIPPED IN VEHICLE FOR TOLL PAYMENT TRANSACTIONS; CLOSED-CIRCUIT TELEVISION CAMERAS; NETWORK MONITORING CAMERAS, NAMELY, FOR SURVEILLANCE (U.S. CLS. 21, 23, 26, 36 AND 38).

ADA HAN, EXAMINING ATTORNEY

**CLASS 9—(Continued).**

SN 77-844,447. SNELL LIMITED, READING, BERKSHIRE, UNITED KINGDOM, FILED 10-8-2009.

# SNELL

THE MARK CONSISTS OF STANDARD CHARACTERS WITHOUT CLAIM TO ANY PARTICULAR FONT, STYLE, SIZE, OR COLOR.

PRIORITY CLAIMED UNDER SEC. 44(D) ON UNITED KINGDOM APPLICATION NO. 2513518, FILED 4-9-2009, REG. NO. 2513518, DATED 9-18-2009, EXPIRES 4-9-2019.

OWNER OF U.S. REG. NOS. 2,258,396 AND 3,061,542.

FOR VIDEO AND AUDIO EDITING AND PROCESSING SOFTWARE, NAMELY, SOFTWARE FOR USE IN COLOUR GAMUT LIMITING, COLOUR CORRECTION, BLACK CLAMPING, COLOUR SPACE CONVERSION, COMPRESSION PRE-PROCESSING, SPATIAL CONVERSION, LUMA AND CHROMA SUBSAMPLE CONVERSION, TEMPORAL STANDARDS CONVERSION, TIME STRETCH, TIME COMPRESSION, VIDEO TO FILM CONVERSION, FILM TO VIDEO CONVERSION, FRAME RATE CONVERSION, SLOW MOTION FILM CAPTURE, STOP FRAME ANIMATION CAPTURE, 3:2 PULL DOWN CONVERSION, I FRAME TO P FRAME CONVERSION, FRAME RATE DECIMATION, FILM CADENCE REPAIR, ROGUE FIELD/FRAME REPAIR, DE-INTERLACING, RE-INTERLACING, ASPECT RATIO CONVERSION, DIGITAL VIDEO EFFECTS, NOISE REDUCTION, IMAGE KEYING, IMAGE OVERLAY, LOGO INSERTION, WATERMARKING, CHARACTER GENERATION, CHARACTER OVERLAY, STRAP INSERTION, TICKER INSERTION, TIME CODING, INSERTION OF CAPTIONS AND SUBTITLES, IMAGE STABILIZATION, DYNAMIC RANGE ENHANCEMENT, DYNAMIC RANGE CONTROL, DYNAMIC REFRAMING, OBJECT RECOGNITION, OBJECT TRACKING, GAIN CONTROL, BLACK LEVEL CONTROL, CONTRAST CONTROL, GAMMA CONTROL, LIFT CONTROL, CLIPPING, COMPOSITE DECODING, COMPOSITE ENCODING, TIMEBASE CORRECTION, SYNCHRONIZATION, LIP SYNC PROCESSING, PROGRAMME DURATION ADJUSTMENT, FRAME OFFSET, PROGRAMME SIGNATURE DETECTION, PROGRAMME GENRE DETECTION, HASH MEASUREMENT, CHECK SUM MEASUREMENT, AUDIO EXTRACTION, MULTIPLEXING, DEMULTIPLEXING, LOUDNESS CONTROL, GRAPHIC EQUALIZATION, CHANNEL EQUALIZATION, AUDIO BALANCING, HIGH PASS FILTERING, LOW PASS FILTERING, BANDPASS FILTERING, SURROUND SOUND PROCESSING, NOISE GENERATION, SILENCE DETECTION, TEST SIGNAL GENERATION, SPEECH TO TEXT CONVERSION, TEXT TO SPEECH CONVERSION, DIALOGUE ENHANCEMENT, AUDIO WARPING, SIBILANCE REMOVAL, WATERMARKING, ENCODING, DECODING; VIDEO AND AUDIO EDITING AND PROCESSING SOFTWARE FOR CREATING TRANSITIONS, NAMELY, CUTS, FADES AND WIPES; VIDEO AND AUDIO EDITING AND PROCESSING SOFTWARE FOR VBI (VERTICAL BLANKING INTERVAL) PROCESSING, NAMELY, EXTRACTION, INSERTION, BLANKING DECODING AND SYNTHESIS QUALITY CONTROL, CHANNEL MAPPING, VOLUME CONTROL; VIDEO AND AUDIO EDITING AND PROCESSING SYSTEMS, NAMELY, COMPUTER HARDWARE, VIDEO PROCESSORS, VIDEO SERVERS, ROUTING SWITCHES, SWITCHING MATRICES; ELECTRONIC NETWORK HARDWARE, NAMELY, COMPUTER HARDWARE, NETWORK ADAPTORS, NETWORK SWITCHES, ROUTERS, HUBS; MODULES, NAMELY, INTEGRATED CIRCUIT MODULES, CIRCUIT BOARD MODULES; CIRCUIT BOARDS, INTEGRATED CIRCUITS AND SOFTWARE, FOR USE IN THE DELIVERY OF TERRESTRIAL, CABLE, SATELLITE, MOBILE, DIRECT-TO-HOME OR INTERNET PROTOCOL TELEVISION; COMPUTER SOFTWARE FOR THE MANAGEMENT, SEARCH, MANUAL AND AUTOMATED CONTROL, AND TRACKING OF VIDEO, AUDIO, IMAGE OR METADATA FILE BASED ASSETS; COMPUTER SOFTWARE FOR THE STATISTICAL AND

**CLASS 9—(Continued).**

FINANCIAL ANALYSIS OF VIDEO, AUDIO, IMAGE OR METADATA FILE BASED WORKFLOWS; COMPUTER HARDWARE, SOFTWARE AND PROCESSORS, NAMELY, REAL-TIME MANUAL AND AUTOMATED DEVICE CONTROLLERS, STATUS LOGGERS, AND ALARMS FOR VIDEO AND AUDIO PROCESSING AND STORAGE DEVICES ACROSS LOCAL AND WIDE AREA NETWORKS; AUDIO-VIDEO PROCESSING APPARATUS AND SOFTWARE, NAMELY, COMPUTER HARDWARE, VIDEO PROCESSORS, AUDIO PROCESSORS AND SOFTWARE FOR USE IN THE ARCHIVING, ARTEFACT-REMOVAL, AUDIO-EMBEDDING, AUDIO DE-EMBEDDING, BROADCASTING, CAPTURE, CHANNEL BRANDING, CLOSED CAPTIONING, COLOUR-CORRECTION, COLOUR-PROCESSING, COLOUR-TIMING, COMMUNICATION, COMPRESSION-DECODING, COMPRESSION-ENCODING, COMPRESSION-TRANSCODING, DE-SPOTTING, TRANSMISSION, DIRT-REMOVAL, DUST REMOVAL, DIGITAL RIGHTS MANAGEMENT, DISPLAY-PROCESSING, DROPOUT-COMPENSATION, EDITING, EFFECT-GENERATION, ENCRYPTION, FRAME SEQUENCE DETECTION, FILM-CADENCE DETECTION AND REPAIR, ORPHAN-FIELD DETECTION AND REPAIR, FILM-TO-VIDEO TRANSFER, VIDEO-TO-FILM TRANSFER, FLICKER-REDUCTION, GRAIN REDUCTION, INGEST, LOGO-GENERATION, MANAGEMENT, MASTERING, MOTION-COMPENSATION, MOTION-ESTIMATION, MOTION-MEASUREMENT, MOTION-PREDICTION, NOISE-REDUCTION, FORMATTING INTO PACKAGES, PICTURE-STABILIZATION, PLAY-OUT, POST-PRODUCTION, PRODUCTION, PROXY-HANDLING, PROJECTION, PUBLISHING, RECORDING, RESTORATION, RETRIEVAL, SCENE CHANGE DETECTION, SCRATCH CONCEALMENT, SHOOTING, STORAGE, STEREO-SCOPIC IMAGE ANALYSIS, SUB-TITLING, TELETXT GENERATION, GENERATION OF REDUCED SIZE THUMB-NAILS OF VIDEO FOR MONITORING, TIMEBASE-CORRECTION, TRANSCODING, TRANS-RATING, UNSTEADINESS-CORRECTION, WATERMARKING, WEAVE-CORRECTION, OF TELEVISION, VIDEO, AUDIO; AUDIO-VISUAL, FILM AND MULTIMEDIA MATERIAL AND CONTENT, DIGITAL INTERMEDIATES THEREOF, OR METADATA ASSOCIATED THEREWITH; AUDIO-VIDEO PROCESSING APPARATUS AND SOFTWARE FOR ASSET-TRACKING, NAMELY, THE TRACKING OF VIDEO, AUDIO, AUDIO-VISUAL, FILM OR MULTIMEDIA MATERIAL OR CONTENT; AUDIO-VIDEO PROCESSING APPARATUS AND SOFTWARE FOR CONVERSION, NAMELY, TELEVISION STANDARDS CONVERSION, FRAME RATE CONVERSION, FILM TO VIDEO CONVERSION, VIDEO TO FILM CONVERSION, UP CONVERSION, DOWN CONVERSION, CROSS CONVERSION; AUDIO-VIDEO PROCESSING APPARATUS AND SOFTWARE FOR CUT-DETECTION, NAMELY, THE DETECTION OF CUTS IN TELEVISION, VIDEO, AUDIO, AUDIO-VISUAL, FILM OR MULTIMEDIA MATERIAL OR CONTENT; AUDIO-VIDEO PROCESSING APPARATUS AND SOFTWARE FOR FILTERING, NAMELY, SPATIAL FILTERING, TEMPORAL FILTERING, AUDIO FILTERING; AUDIO-VIDEO PROCESSING APPARATUS AND SOFTWARE FOR KEYING, NAMELY, THE GENERATION OR USE OF A KEY SIGNAL IN COMPOSITING OF TELEVISION, VIDEO OR FILM IMAGES; AUDIO-VIDEO PROCESSING APPARATUS AND SOFTWARE FOR REFRAMING, NAMELY, THE PROCESSING OF TELEVISION, VIDEO OR FILM IMAGES TO CHANGE THE SHAPE OR SIZE OF THE IMAGE; AUDIO-VIDEO PROCESSING APPARATUS AND SOFTWARE FOR SEGMENTATION, NAMELY, THE SEGMENTATION OF ONE OR MORE OBJECTS IN AN IMAGE OR VIDEO OR THE SEGMENTATION OF AN IMAGE OR VIDEO INTO FOREGROUND AND BACKGROUND; AUDIO-VIDEO PROCESSING APPARATUS AND SOFTWARE FOR SERIALIZING, NAMELY, CONVERTING FROM PARALLEL FORM TO SERIAL FORM; AUDIO-VIDEO PROCESSING APPARATUS AND SOFTWARE FOR DESERIALIZING, NAMELY, CONVERTING FROM SERIAL FORM TO PARALLEL FORM; AUDIO-VIDEO PROCESSING APPARATUS AND SOFTWARE FOR REPURPOSING OF VIDEO CONTENT PRODUCED FOR ONE MEDIUM SUCH AS FILM, TELEVISION, DVD, INTERNET, MOBILE TELEPHONY AND HAND-HELD DEVICES FOR USE WITH A DIFFERENT MEDIUM; AMPLIFIERS; APPARATUS FOR RECORDING, TRANSMISSION OR REPRODUCTION OF SOUND, VIDEO OR

**CLASS 9—(Continued).**

IMAGES; VIDEO PROCESSORS FOR CONVERTING THE ASPECT RATIO OF FILM AND VIDEO; CIRCUIT BOARDS; COLOR CORRECTORS, NAMELY, COMPUTER HARDWARE AND CIRCUIT BOARDS FOR ADJUSTING THE COLOR QUALITY OF VIDEO, TELEVISION OR FILM; COMPUTER GRAPHICS BOARDS; COMPUTER GRAPHICS SOFTWARE; COMPUTER HARDWARE; COMPUTER INTERFACE BOARDS; COMPUTER NETWORK HUBS, SWITCHES AND ROUTERS; COMPUTER PROGRAMS FOR EDITING IMAGES, SOUND AND VIDEO; COMPUTER SOFTWARE FOR USE IN RELATION TO DIGITAL ANIMATION AND SPECIAL EFFECTS OF IMAGES; COMPUTER SOFTWARE FOR USE IN THE ENCRYPTION AND DECRYPTION OF DIGITAL FILES, INCLUDING AUDIO, VIDEO, TEXT, BINARY, STILL IMAGES, GRAPHICS AND MULTIMEDIA FILES; COMPUTER HARDWARE, VIDEO PROCESSORS, AND SOFTWARE FOR THE REPURPOSING OF VIDEO CONTENT PRODUCED FOR ONE MEDIUM SUCH AS FILM, TELEVISION, DVD, INTERNET, MOBILE TELEPHONY AND HAND-HELD DEVICES FOR USE WITH A DIFFERENT MEDIUM; CONVERTERS; DATA COMPRESSION SOFTWARE; DECODERS, NAMELY, TELEVISION DECODERS, COMPRESSION DECODERS, NAMELY, DECODERS FOR DECODING COMPRESSED VIDEO AND AUDIO SIGNALS; DATA DECODERS, NAMELY, DECODERS FOR DECODING METADATA FOR VIDEO, AUDIO AND IMAGES; DEMODULATORS; DE-MULTIPLEXERS; DIGITAL SIGNAL PROCESSORS; DIGITIZERS, NAMELY, COMPUTER HARDWARE AND CIRCUIT BOARDS FOR CONVERTING FROM ANALOG SIGNALS TO DIGITAL SIGNALS; DISPLAY CIRCUIT BOARDS, NAMELY, VIDEO DISPLAY CARDS; VIDEO AND AUDIO DISTRIBUTORS, NAMELY, COMPUTER HARDWARE FOR DISTRIBUTING VIDEO AND AUDIO SIGNALS; VIDEO AND AUDIO EDITORS, NAMELY, COMPUTER HARDWARE AND CIRCUIT BOARDS FOR THE EDITING OF VIDEO AND AUDIO CONTENT; ELECTRONIC CODING UNITS; ELECTRONIC CONTROL SYSTEMS FOR MACHINES; ELECTRONIC CONTROLLERS, NAMELY, CONTROLLERS FOR ELECTRONICALLY CONTROLLING VIDEO AND AUDIO PROCESSING AND STORAGE DEVICES FOR USE WITH TELEVISION, FILM, VIDEO, IMAGE AND AUDIO SIGNALS AND FILES, WHETHER COMPRESSED, PARTIALLY COMPRESSED OR UNCOMPRESSED; ELECTRONIC INDICATOR PANELS; ENCODERS; FIBRE OPTICS; INTEGRATED CIRCUIT MODULES; INTEGRATED CIRCUITS; LOGO GENERATORS, NAMELY, COMPUTER HARDWARE AND VIDEO PROCESSORS FOR THE DESIGN AND CREATION OF LOGOS; VIDEO, AUDIO OR AUDIOVISUAL MIXERS; MONITORS, NAMELY, VIDEO, TELEVISION AND COMPUTER MONITORS; MULTIPLEXERS; ELECTRONIC NOISE REDUCERS, NAMELY, APPARATUS FOR REDUCING NOISE IN TELEVISION, FILM, VIDEO, IMAGE AND AUDIO SIGNALS AND FILES, WHETHER COMPRESSED, PARTIALLY COMPRESSED OR UNCOMPRESSED; PRE-AMPLIFIERS; RECEIVERS, NAMELY, VIDEO, TELEVISION, SATELLITE RECEIVERS; SIGNAL PROCESSORS; SOFTWARE FOR PROCESSING IMAGES, GRAPHICS AND TEXT; TELEVISION VIDEO STANDARDS CONVERTERS; COMMUNICATIONS TRANSMISSION APPARATUS; TV AND VIDEO CONVERTERS; VIDEO SERVERS; VIDEO PROCESSORS; ALL THE ABOVE FOR USE WITH TELEVISION, FILM, VIDEO, IMAGE OR AUDIO SIGNALS OR FILES, WHETHER COMPRESSED, PARTIALLY COMPRESSED OR UNCOMPRESSED; COMPUTER HARDWARE AND SOFTWARE FOR THE ANALYZING, CONVERTING, FORMATTING, MAPPING, MODIFYING, PLAYING, PROCESSING, STORING, SYNCHRONIZING AND TRANSMITTING OF TELEVISION, VIDEO, AUDIO AND FILM; COMPUTER HARDWARE

**CLASS 9—(Continued).**

AND SOFTWARE FOR THE ANALYZING, AUTOMATING, BACKING-UP AND RESTORING, CONTROLLING, DISASTER RECOVERY, GUIDING, LOGGING, MANAGING MEASURING, MONITORING, QUALITY CONTROL, REDUNDANCY SWITCHING, SECURING, TRACKING, TESTING, AND VISUALIZATION OF TELEVISION, FILM, VIDEO, IMAGE AND AUDIO SIGNALS OR FILES, WHETHER COMPRESSED, PARTIALLY COMPRESSED OR UNCOMPRESSED; INTEGRATED CIRCUITS, CIRCUIT BOARDS, AND SPARE PARTS FOR USE WITH ANY OF THE FOREGOING (U.S. CLS. 21, 23, 26, 36 AND 38).

DAVID TOOLEY, EXAMINING ATTORNEY

---

SN 77-858,673. ELECTRIC POWER GROUP, LLC, PASADENA, CA. FILED 10-27-2009.



NO CLAIM IS MADE TO THE EXCLUSIVE RIGHT TO USE "E SPDC", APART FROM THE MARK AS SHOWN.

THE COLOR(S) BLACK, DARK GRAY, GRAY, RED, AND BLUE IS/ARE CLAIMED AS A FEATURE OF THE MARK.

THE MARK CONSISTS OF BLACK LOWER CASE ITALIZED "E", DARK GRAY LOWERCASE "S", CAPITALIZED BOLD LETTERS "PDC" IN GRAY, RED LINE WITH ARROW ON ONE END AND A CIRCLE ON THE OTHER UNDERLINING "E SPDC". GRAY AND BLUE COMPACT DISC DESIGN WITH BLUE ARROW PLACED BETWEEN THE "E" AND "S" AND A GRAY SHADOW UNDER THE COMPACT DISC.

FOR COMPUTER SOFTWARE PLATFORMS FOR RECEIVING TIME-STAMPED ELECTRIC POWER DATA FROM MULTIPLE SOURCES, FOR PERFORMING THE FUNCTIONS OF TIME, SYNCHRONIZATION, DATA AGGREGATION, PROCESSING AND ELECTRONIC TRANSMITTAL OF MULTIPLE STREAMS IN REAL TIME TO SYNCHROPHASOR APPLICATIONS AT UTILITY OR GRID CONTROL CENTER (U.S. CLS. 21, 23, 26, 36 AND 38).

FIRST USE 5-1-2009; IN COMMERCE 5-1-2009.

MATTHEW EINSTEIN, EXAMINING ATTORNEY



**CLASS 9—(Continued).**

SN 77-879,864. WORLD WRESTLING ENTERTAINMENT, INC., STAMFORD, CT. FILED 11-24-2009.

# VENGEANCE

THE MARK CONSISTS OF STANDARD CHARACTERS WITHOUT CLAIM TO ANY PARTICULAR FONT, STYLE, SIZE, OR COLOR.

FOR CINEMATOGRAPHIC FILMS FEATURING PROFESSIONAL SPORTS ENTERTAINMENT, NAMELY, WRESTLING; TELEVISION FILMS FEATURING PROFESSIONAL SPORTS ENTERTAINMENT, NAMELY, WRESTLING; MOTION PICTURE FILMS IN THE NATURE OF SPORTS ENTERTAINMENT; PRE-RECORDED PHONOGRAPH RECORDS FEATURING PROFESSIONAL SPORTS ENTERTAINMENT, NAMELY, WRESTLING; PRE-RECORDED COMPACT DISCS FEATURING PROFESSIONAL SPORTS ENTERTAINMENT, NAMELY, WRESTLING; PRE-RECORDED VIDEO TAPES FEATURING PROFESSIONAL SPORTS ENTERTAINMENT, NAMELY, WRESTLING; PRE-RECORDED VIDEO CASSETTE TAPES FEATURING PROFESSIONAL SPORTS ENTERTAINMENT, NAMELY, WRESTLING; PRE-RECORDED DVDS FEATURING PROFESSIONAL SPORTS ENTERTAINMENT, NAMELY, WRESTLING; PRE-RECORDED AUDIO CASSETTES FEATURING PROFESSIONAL SPORTS ENTERTAINMENT, NAMELY, WRESTLING (U.S. CLS. 21, 23, 26, 36 AND 38).

LEIGH CAROLINE CASE, EXAMINING ATTORNEY

SN 77-899,054. CTM MAGNETICS, TEMPE, AZ. FILED 12-22-2009.

# CTM Magnetics

THE MARK CONSISTS OF STANDARD CHARACTERS WITHOUT CLAIM TO ANY PARTICULAR FONT, STYLE, SIZE, OR COLOR.

NO CLAIM IS MADE TO THE EXCLUSIVE RIGHT TO USE "MAGNETICS", APART FROM THE MARK AS SHOWN.

FOR APPARATUS AND INSTRUMENTS FOR CONVEYING, DISTRIBUTING, TRANSFORMING, STORING, REGULATING OR CONTROLLING ELECTRIC CURRENT; DISTRIBUTION TRANSFORMERS; ELECTRIC TRANSFORMERS; ELECTRIC VOLTAGE TRANSFORMERS; ELECTRICAL INDUCTORS; ELECTRICAL RELAYS AND TRANSFORMERS; ELECTRICAL TRANSFORMERS; ELECTRICAL TRANSFORMERS; LOW PASS INDUCTOR FILTER USED IN HIGH POWER ELECTRICAL APPLICATIONS; POWER TRANSFORMERS FOR AMPLIFICATION; STEP DOWN TRANSFORMERS; STEP UP TRANSFORMERS; TRANSFORMERS; WELDING TRANSFORMERS (U.S. CLS. 21, 23, 26, 36 AND 38).

FIRST USE 6-1-1974; IN COMMERCE 6-1-1974.  
KATINA MISTER, EXAMINING ATTORNEY

**CLASS 9—(Continued).**

SN 77-918,577. WORLD WRESTLING ENTERTAINMENT, INC., STAMFORD, CT. FILED 1-22-2010.

# NXT

THE MARK CONSISTS OF STANDARD CHARACTERS WITHOUT CLAIM TO ANY PARTICULAR FONT, STYLE, SIZE, OR COLOR.

FOR DOWNLOADABLE GRAPHICS AND MUSIC VIA A GLOBAL COMPUTER NETWORK AND WIRELESS DEVICES; DECORATIVE REFRIGERATOR MAGNETS; VIDEO AND COMPUTER GAME TAPES FEATURING PROFESSIONAL WRESTLING, VIDEO AND COMPUTER GAME DISCS FEATURING PROFESSIONAL WRESTLING, VIDEO AND COMPUTER GAME CASSETTES FEATURING PROFESSIONAL WRESTLING, VIDEO AND COMPUTER GAME CARTRIDGES FEATURING PROFESSIONAL WRESTLING, VIDEO AND COMPUTER GAME CD-ROMS FEATURING PROFESSIONAL WRESTLING, VIDEO AND COMPUTER GAME SOFTWARE FEATURING PROFESSIONAL WRESTLING; CINEMATOGRAPHIC AND TELEVISION FILMS, NAMELY, MOTION PICTURE FILMS IN THE NATURE OF SPORTS ENTERTAINMENT AND FEATURING PROFESSIONAL WRESTLING; PRE-RECORDED PHONOGRAPH RECORDS, PRE-RECORDED COMPACT DISCS, PRE-RECORDED VIDEO TAPES, PRE-RECORDED VIDEO CASSETTE TAPES, PRE-RECORDED DVDS AND PRE-RECORDED AUDIO CASSETTES, ALL FEATURING PROFESSIONAL WRESTLING; INTERACTIVE VIDEO GAME PROGRAMS AND COMPUTER GAME CARTRIDGES FEATURING PROFESSIONAL WRESTLING; MOUSE PADS; DISPOSABLE CAMERAS (U.S. CLS. 21, 23, 26, 36 AND 38).

NATALIE POLZER, EXAMINING ATTORNEY

SN 77-928,941. MAXIM INTEGRATED PRODUCTS, INC., SUNNYVALE, CA. FILED 2-5-2010.

# VERICALL

THE MARK CONSISTS OF STANDARD CHARACTERS WITHOUT CLAIM TO ANY PARTICULAR FONT, STYLE, SIZE, OR COLOR.

OWNER OF U.S. REG. NO. 3,205,074.

FOR COMMUNICATIONS SOFTWARE TO CONTROL THE OPERATION OF WIRED AND WIRELESS COMMUNICATIONS DEVICES INVOLVING VOICE, VIDEO, MULTIMEDIA AND DATA TRANSMISSIONS (U.S. CLS. 21, 23, 26, 36 AND 38).

BARNEY CHARLON, EXAMINING ATTORNEY

**CLASS 9—(Continued).**

SN 77-931,584. W2007 STRATOSPHERE PROPCO, L.P., LAS VEGAS, NV. FILED 2-9-2010.



OWNER OF U.S. REG. NOS. 2,086,400, 2,086,401 AND 3,212,812.

NO CLAIM IS MADE TO THE EXCLUSIVE RIGHT TO USE "LAS VEGAS", APART FROM THE MARK AS SHOWN.

THE MARK CONSISTS OF THE WORDS "SKY JUMP STRATOSPHERE LAS VEGAS" STAGGERED AND POSITIONED VERTICALLY OVER A TARGET.

FOR DIGITAL MEDIA, NAMELY, CDS AND DVDS FEATURING SOUVENIR PICTURES AND VIDEOS; MAGNETIC CODED GIFT CARDS; MAGNETIC IDENTIFYING CARDS; MAGNETS; MOUSEPADS; SLOT MACHINES; SUNGLASSES (U.S. CLS. 21, 23, 26, 36 AND 38).  
PAUL E. FAHRENKOPF, EXAMINING ATTORNEY

SN 77-932,928. INNOV8 TRANSPORT INC., AUSTIN, TX. FILED 2-10-2010.



THE COLOR(S) DARK GREEN AND LIME GREEN AND BLACK IS/ARE CLAIMED AS A FEATURE OF THE MARK.

THE MARK CONSISTS OF THE WORDING "SKYGRID" IN STYLIZED FORM, WITH AN ARROW DESIGN RUNNING FROM LEFT TO RIGHT THROUGH THE LETTERS "SKY" AND ABOVE THE LETTERS "GRID". THE LETTERS "SKY" ARE IN DARK GREEN, THE LETTERS "GRID" ARE IN BLACK, AND THE ARROW IS COMPOSED OF ALTERNATING DARK GREEN AND LIME GREEN.

FOR SYSTEM COMPRISED OF COMPUTER SOFTWARE AND HARDWARE, NAMELY, ELECTRIC CABLES, WIRES, CONDUCTORS AND CONNECTION FITTINGS THEREFOR, ELECTRICAL RELAYS AND TRANSFORMERS, ELECTRIC CIRCUIT SWITCHES, BROADBAND RADIOS TO PROVIDE ELECTRICITY AND A MEANS OF COMMUNICATION TO OPERATE ELECTRIFIED HIGHWAYS (U.S. CLS. 21, 23, 26, 36 AND 38).

JANET LEE, EXAMINING ATTORNEY

**CLASS 9—(Continued).**

SN 77-947,032. LITL LLC, BOSTON, MA. FILED 3-1-2010.

# WEBBOX

THE MARK CONSISTS OF STANDARD CHARACTERS WITHOUT CLAIM TO ANY PARTICULAR FONT, STYLE, SIZE, OR COLOR.

FOR COMPUTER SOFTWARE AND HARDWARE FOR CONNECTING COMPUTERS; COMPUTER INTERFACE DEVICES; COMPUTER PERIPHERAL DEVICES; COMPUTER SOFTWARE AND HARDWARE FOR CONNECTING AND CONTROLLING A VARIETY OF ELECTRONIC DEVICES AND SELECTIVELY DISPLAYING THEIR OUTPUTS (U.S. CLS. 21, 23, 26, 36 AND 38).  
KEVIN CORWIN, EXAMINING ATTORNEY

SN 77-947,039. LITL LLC, BOSTON, MA. FILED 3-1-2010.

# LITL WEBBOX

THE MARK CONSISTS OF STANDARD CHARACTERS WITHOUT CLAIM TO ANY PARTICULAR FONT, STYLE, SIZE, OR COLOR.

OWNER OF U.S. REG. NOS. 3,734,614, 3,797,071 AND 3,797,082.

FOR COMPUTER SOFTWARE AND HARDWARE FOR CONNECTING COMPUTERS; COMPUTER INTERFACE DEVICES; COMPUTER PERIPHERAL DEVICES; COMPUTER SOFTWARE AND HARDWARE FOR CONNECTING AND CONTROLLING A VARIETY OF ELECTRONIC DEVICES AND SELECTIVELY DISPLAYING THEIR OUTPUTS (U.S. CLS. 21, 23, 26, 36 AND 38).  
KEVIN CORWIN, EXAMINING ATTORNEY

SN 77-947,344. REGENTS OF THE UNIVERSITY OF MINNESOTA, MINNEAPOLIS, MN. FILED 3-1-2010.

# Seeing IS Believing

THE MARK CONSISTS OF STANDARD CHARACTERS WITHOUT CLAIM TO ANY PARTICULAR FONT, STYLE, SIZE, OR COLOR.

OWNER OF U.S. REG. NO. 2,590,679.  
FOR DVDS FEATURING TRAINING, PROFESSIONAL DEVELOPMENT, AND EDUCATION OF MENTAL HEALTH PRACTITIONERS (U.S. CLS. 21, 23, 26, 36 AND 38).

FIRST USE 4-30-2006; IN COMMERCE 4-30-2006.  
MARIAM MAHMOUDI, EXAMINING ATTORNEY

**CLASS 9—(Continued).**

SN 77-949,601. SHIMADZU CORPORATION, KYOTO, JAPAN, FILED 3-3-2010.

ASSP

THE MARK CONSISTS OF STANDARD CHARACTERS WITHOUT CLAIM TO ANY PARTICULAR FONT, STYLE, SIZE, OR COLOR.

PRIORITY CLAIMED UNDER SEC. 44(D) ON JAPAN APPLICATION NO. 2010-012228, FILED 2-19-2010, REG. NO. 5380586, DATED 1-7-2011, EXPIRES 1-7-2021.

FOR GAS CHROMATOGRAPH MASS SPECTROMETRY AND THEIR PARTS; AND COMPUTER PROGRAMS USED FOR THE CONTROL OF MASS SPECTROMETRY (U.S. CLS. 21, 23, 26, 36 AND 38).  
WARREN L. OLANDRIA, EXAMINING ATTORNEY

---

SN 77-950,539. OPEN ACCESS TECHNOLOGY INTERNATIONAL, INC., MINNEAPOLIS, MN. FILED 3-4-2010.

WEBVIRTUAL

THE MARK CONSISTS OF STANDARD CHARACTERS WITHOUT CLAIM TO ANY PARTICULAR FONT, STYLE, SIZE, OR COLOR.

FOR ENERGY MANAGEMENT SOFTWARE, NAMELY, SOFTWARE FOR MANAGING VIRTUAL SUBSTATIONS AND VIRTUAL PLANTS (U.S. CLS. 21, 23, 26, 36 AND 38).  
ELI HELLMAN, EXAMINING ATTORNEY

**CLASS 9—(Continued).**

SN 77-953,041. INDUSTRIAL AND FINANCIAL SYSTEMS, IFS AB, LINKÖPING, SWEDEN, FILED 3-8-2010.



OWNER OF U.S. REG. NO. 2,831,118.  
THE MARK CONSISTS OF THE LETTERS "IFS" SHOWN IN A DIAGONAL FORM INSIDE A SQUARE BOX.

FOR COMPUTER SOFTWARE THAT PROVIDES INTEGRATED BUSINESS MANAGEMENT INTELLIGENCE BY COMBINING INFORMATION FROM VARIOUS BUSINESS OBJECTS, FOR MANAGING INTERNAL AND EXTERNAL RESOURCES, NAMELY, ENTERPRISE RESOURCE PLANNING SYSTEMS, NAMELY, MANUFACTURING, SUPPLY CHAIN AND DISTRIBUTION, FINANCIALS, SALES, PURCHASING, E-BUSINESS APPLICATIONS, SERVICE AND MAINTENANCE MANAGEMENT, HUMAN RESOURCES, PROJECTS, CUSTOMER RELATIONSHIPS, DOCUMENT MANAGEMENT AND RELATED CORPORATE OPERATIONAL FUNCTIONS SO THAT INFORMATION FLOWS BETWEEN FUNCTIONS IN A PARTICULAR APPLICATION, AND ELECTRONIC PUBLICATIONS RECORDED ON COMPUTER MEDIA, NAMELY, MANUALS AND PAMPHLETS IN THE FIELD OF INTEGRATED BUSINESS MANAGEMENT SOFTWARE (U.S. CLS. 21, 23, 26, 36 AND 38).

FIRST USE 8-1-1987; IN COMMERCE 8-1-1987.  
GRETCHEN ULRICH, EXAMINING ATTORNEY

---

SN 77-954,573. TRUEVISION SYSTEMS, INC., SANTA BARBARA, CA. FILED 3-9-2010.

TrueZoom

THE MARK CONSISTS OF STANDARD CHARACTERS WITHOUT CLAIM TO ANY PARTICULAR FONT, STYLE, SIZE, OR COLOR.

OWNER OF U.S. REG. NO. 3,305,525.  
FOR SOFTWARE FOR 3D HIGH DEFINITION REAL TIME DIGITAL CAMERAS THAT ALLOWS AND ENABLES ZOOMING AND PANNING OPTIONS (U.S. CLS. 21, 23, 26, 36 AND 38).

FIRST USE 10-1-2009; IN COMMERCE 10-1-2009.  
KEVIN CORWIN, EXAMINING ATTORNEY

**CLASS 9—(Continued).**

SN 77-956,621. SMARTDRAW, LLC, SAN DIEGO, CA. FILED 3-11-2010.

**THE WORLD'S FIRST VISUAL  
PROCESSOR**

THE MARK CONSISTS OF STANDARD CHARACTERS WITHOUT CLAIM TO ANY PARTICULAR FONT, STYLE, SIZE, OR COLOR.

NO CLAIM IS MADE TO THE EXCLUSIVE RIGHT TO USE "WORLD'S FIRST", APART FROM THE MARK AS SHOWN.

FOR COMPUTER SOFTWARE FOR DRAWING AND DESIGN PROJECTS, NAMELY, COMPUTER GRAPHICS SOFTWARE; DOWNLOADABLE COMPUTER SOFTWARE FOR DRAWING AND DESIGN PROJECTS, NAMELY, COMPUTER GRAPHICS SOFTWARE (U.S. CLS. 21, 23, 26, 36 AND 38).

BARBARA BROWN, EXAMINING ATTORNEY

---

SN 77-957,819. PHOENIX WIRELESS, INC., HATFIELD, PA. FILED 3-12-2010.

**AZURA**

THE MARK CONSISTS OF STANDARD CHARACTERS WITHOUT CLAIM TO ANY PARTICULAR FONT, STYLE, SIZE, OR COLOR.

FOR CELL PHONE ACCESSORIES, NAMELY, PHONE SKINS AND PHONE SHIELDS (U.S. CLS. 21, 23, 26, 36 AND 38).

LAURA KOVALSKY, EXAMINING ATTORNEY

---

SN 77-966,021. COBRA ELECTRONICS CORPORATION, CHICAGO, IL. FILED 3-23-2010.

**PHONELYNX**

THE MARK CONSISTS OF STANDARD CHARACTERS WITHOUT CLAIM TO ANY PARTICULAR FONT, STYLE, SIZE, OR COLOR.

FOR A DEVICE FOR ENABLING CONNECTIVITY BETWEEN MULTIPLE VOICE AND DATA COMMUNICATIONS DEVICES, NAMELY, A WIRELESS TELEPHONE AND A LANDLINE PHONE (U.S. CLS. 21, 23, 26, 36 AND 38).

DAVID TAYLOR, EXAMINING ATTORNEY

**CLASS 9—(Continued).**

SN 77-967,047. CAMBRIDGE AUDIO LIMITED, LONDON, UNITED KINGDOM, FILED 3-24-2010.



OWNER OF ERPN CMNTY TM OFC REG. NO. 008964397, DATED 9-2-2010, EXPIRES 3-18-2020.

THE COLOR(S) LIGHT BLUE, DARK BLUE, AND WHITE IS/ARE CLAIMED AS A FEATURE OF THE MARK.

THE MARK CONSISTS OF THE FOLLOWING: A CLUSTER OF CIRCLES ON A WHITE BACKGROUND WITH THE CENTER CIRCLE AND TOP HALF APPEARING IN LIGHT BLUE AND THE BOTTOM PORTION APPEARING IN DARK BLUE AND THE STYLIZED WORD "INTEGRALE" IN DARK BLUE TO THE RIGHT OF THE DESIGN.

THE ENGLISH TRANSLATION OF "INTEGRALE" IN THE MARK IS "COMPLETE".

FOR APPARATUS FOR RECORDING, TRANSMISSION OR REPRODUCTION OF SOUND OR IMAGES; AMPLIFIERS, RADIO RECEIVERS AND RADIO SIGNAL TUNERS, PHONOGRAPH RECORD PLAYERS, DIGITAL TO ANALOGUE CONVERTERS, MEDIA PLAYERS, PORTABLE MEDIA PLAYERS AND PROTECTIVE COVERS AND CASES FOR MEDIA PLAYERS, HEADPHONES, TONE ARMS FOR RECORD PLAYERS, ELECTRICAL PICKUPS FOR USE WITH GRAMOPHONES, LOUDSPEAKERS, HI-FIDELITY SOUND RECORDING AND SOUND REPRODUCING APPARATUS AND INSTRUMENTS; RECORD PLAYERS, DIGITAL MEDIA SERVER, DIGITAL MEDIA RECEIVER AND DIGITAL MEDIA PLAYER, ELECTRIC AUDIO PLAYBACK UNITS, SOUND AND VIDEO RECORDING AND PLAYBACK MACHINES, COMPACT DISC PLAYERS, DIGITAL VIDEO DISC PLAYERS, OPTICAL DISC PLAYERS, ELECTRONIC DOCKING STATIONS FOR PORTABLE MEDIA PLAYERS, RADIOS, MICROPHONES; ELECTRIC INTERCONNECTOR CABLES AND ASSOCIATED CABLE CONNECTORS, ELECTRIC CABLES, TELEVISIONS AND VIDEO RECORDERS, ALL OF THE FOREGOING EXCEPT AS USED IN VEHICLES (U.S. CLS. 21, 23, 26, 36 AND 38).

LINDA M. KING, EXAMINING ATTORNEY

---

SN 77-969,479. HONEYWELL INTERNATIONAL INC., MORRISTOWN, NJ. FILED 3-26-2010.

**LIMITLESS**

THE MARK CONSISTS OF STANDARD CHARACTERS WITHOUT CLAIM TO ANY PARTICULAR FONT, STYLE, SIZE, OR COLOR.

FOR WIRELESS SWITCHES, NAMELY, LIMIT SWITCHES; WIRELESS TRANSMITTERS; WIRELESS SENSORS FOR DETERMINING POSITION, VELOCITY, ACCELERATION, TEMPERATURE, VIBRATION, LOAD, PRESSURE AND FLOW (U.S. CLS. 21, 23, 26, 36 AND 38).

MARY ROSSMAN, EXAMINING ATTORNEY

**CLASS 9—(Continued).**

SN 78-159,533. LINE9, LLC, CAPE CORAL, FL. FILED 8-30-2002.

**TEK9**

FOR COMPUTER APPLICATIONS SOFTWARE THAT INTEGRATES EXISTING SYSTEMS AND DATABASES WITH THE INTERNET, SOLD ON CD-ROM (U.S. CLS. 21, 23, 26, 36 AND 38).

FIRST USE 7-1-1993; IN COMMERCE 7-1-1993.  
WILLIAM VERHOSEK, EXAMINING ATTORNEY

SN 79-070,423. YUEQING XINDALI INDUSTRY; CO., LTD, ZHENGJIANG, CHINA, FILED 8-31-2008.



OWNER OF INTERNATIONAL REGISTRATION 1006514 DATED 8-31-2008, EXPIRES 8-31-2018.

THE MARK CONSISTS OF THE WORD "XINDALI", NON-LATIN CHARACTERS WHICH TRANSLITERATE TO "XINDALI", AND A SPACE ROCKET DESIGN WITHIN AN INCOMPLETE CIRCLE.

THE ENGLISH TRANSLATION OF "XINDALI" IN THE MARK IS "TRUST REALIZE SHARP".

THE NON-LATIN CHARACTERS IN THE MARK TRANSLITERATE TO "XINDALI".

FOR ELECTRONIC COMPONENTS FOR USE IN INDUSTRIAL MACHINERY, NAMELY, IN THE NATURE OF CONTROLLING, REGULATING AND SWITCHING LIQUID CRYSTAL DISPLAYS AND ELECTRONIC INTERFACE EQUIPMENT FOR MACHINE TOOLS TO INPUT OR OUTPUT CNC (COMPUTER NUMERICAL CONTROL) DATA ON AUTOMATIC STAMPING MACHINES, AIR SUCTION MACHINES, AUTOMOTIVE FRAME STRETCHING MACHINES, COMPRESSION MOULDING MACHINES, CUTTING MACHINES FOR METALWORKING, DIE-STAMPING MACHINES, DIE-CUTTING MACHINES, DRILLING MACHINES FOR METALWORKING, EMBOSSING MACHINES, EMBROIDERY MACHINES, EXCAVATING MACHINES, INDUSTRIAL MACHINERY, NAMELY, ELECTROMECHANICAL MARKING MACHINES, INDUSTRIAL PRINTING MACHINES, INDUSTRIAL SEWING MACHINES, INJECTION MOULDING MACHINES, LASER ENGRAVING MACHINES, LAMINATING MA-

**CLASS 9—(Continued).**

CHINES FOR INDUSTRIAL USE, LASER WELDING MACHINES, MACHINES FOR MANUFACTURING SEMICONDUCTORS, METAL WORKING MACHINES, MILLING MACHINES, PACKAGING MACHINES, PRINTING MACHINES FOR COMMERCIAL OR INDUSTRIAL USE, SEMICONDUCTOR MANUFACTURING MACHINES, SEMICONDUCTOR SUBSTRATES MANUFACTURING MACHINES, SEMICONDUCTOR WAFER PROCESSING MACHINES, SHEARING MACHINES FOR METALWORKING, TEXTILE WASHING MACHINES FOR INDUSTRIAL PURPOSES, WOOD BEATING MACHINES, WOOD CHIPPING MACHINES, WOOD DRILLING MACHINES, WOOD GRINDING MACHINES, YARN WINDING MACHINES, YARN WARPING MACHINES, YARN TWISTING MACHINES AND PARTS THEREOF; ELECTRICAL COMPONENTS FOR HOUSEHOLD APPLIANCES, NAMELY, ELECTRICAL CONTACTS; POWER SWITCHES; FUSES; ELECTRIC RELAYS; LOW-VOLTAGE ELECTRICAL COMPONENTS, NAMELY, SWITCHES, ISOLATING SWITCHES, CONTACTS (U.S. CLS. 21, 23, 26, 36 AND 38).

BARNEY CHARLON, EXAMINING ATTORNEY

SN 79-072,047. MDEXX GMBH, FED REP GERMANY, FILED 4-7-2009.

**MDEXX**

THE MARK CONSISTS OF STANDARD CHARACTERS WITHOUT CLAIM TO ANY PARTICULAR FONT, STYLE, SIZE, OR COLOR.

PRIORITY DATE OF 2-27-2009 IS CLAIMED.

OWNER OF INTERNATIONAL REGISTRATION 1010819 DATED 4-7-2009, EXPIRES 4-7-2019.

FOR TRANSFORMERS; POWER SUPPLIES; POWER SUPPLY SYSTEMS COMPRISED MAINLY OF TRANSFORMERS, ELECTRICAL CHOKES, OR ELECTRONIC POWER SUPPLIES IN COMBINATION WITH MANUAL, MAGNETIC AND SOLID-STARTERS AND CONTROLLERS, THERMAL, MAGNETIC AND SOLID-STATE OVERLOAD RELAYS, PUSH BUTTON STATIONS, COMPRISED OF SELECTOR SWITCHES AND PILOT LIGHTS, CONTROL CIRCUIT SWITCHES AND RELAYS, FLOAT, FLOW, PRESSURE, AND VACUUM-OPERATED SWITCHES, RESISTORS AND RHEOSTATS, PROXIMITY SWITCHES, TIME-DELAY RELAYS AND SWITCHES, RESISTORS AND RHEOSTATS INTENDED FOR INDUSTRIAL HEATING AND LIGHTING, NAMELY, THOSE FOR MOTOR GENERATOR FIELDS, CONTROLS INTENDED FOR INDUSTRIAL HEATING AND LIGHTING, SOLID-STATE TIME-DELAY RELAYS, PROGRAMMABLE CONTROLLERS, NUMERICAL CONTROL SYSTEMS, LIGHTING DIMMER SYSTEMS AND CONTROLS, MERCURY-TUBE SWITCHES, DEFINITE PURPOSE CONTROLLERS, SOLID-STATE LOGIC CONTROLLERS AND INDUSTRIAL MICROPROCESSOR/COMPUTER SYSTEMS; CHOKES; FILTERS, NAMELY, FILTERS CONSISTING OF CHOKES IN COMBINATION WITH ELECTRICAL CHOKES, CAPACITATORS FOR USE IN DRIVE TECHNOLOGY AS RADIO INTERFERENCE SUPPRESSION FILTERS OR AS VOLTAGE RISE LIMITING DV/DT FILTERS OR AS SINEWAVE FILTERS OR FOR USE IN ELECTRICAL POWER SYSTEMS AS HARMONIC FILTERS; AERATORS (U.S. CLS. 21, 23, 26, 36 AND 38).

JANET LEE, EXAMINING ATTORNEY

**CLASS 9—(Continued).**

SN 79-076,498. CHANKING OPTICAL (ZHANGZHOU); CO., LTD, CHINA, FILED 11-2-2009.



PRIORITY DATE OF 9-15-2009 IS CLAIMED.  
OWNER OF INTERNATIONAL REGISTRATION 1022557 DATED 11-2-2009, EXPIRES 11-2-2019.

THE MARK CONSISTS OF THE WORDING "BLACK BOX" IN A STYLIZED FONT APPEARING BENEATH A DESIGN THAT CONSISTS OF A CUBE INSCRIBED WITH THE LETTERS "BB" BACK TO BACK.

FOR SPECTACLES (OPTICS); EYEGLASSES; EYEGLASS FRAMES; CONTACT LENSES; SUNGLASSES; SPECTACLE FRAMES; EYEGLASS CHAINS; SPECTACLE CASES; OPTICAL LENSES; SPECTACLE GLASSES (U.S. CLS. 21, 23, 26, 36 AND 38).

RENEE MCCRAY, EXAMINING ATTORNEY

---

SN 79-083,090. DEVIALET, F-75001 PARIS, FRANCE, FILED 5-5-2010.



OWNER OF INTERNATIONAL REGISTRATION 1040194 DATED 5-5-2010, EXPIRES 5-5-2020.

THE MARK CONSISTS OF THE WORD "DEVIALET" BELOW A DESIGN ELEMENT CONSISTING OF THE LETTER "D" IN A CIRCLE, SURROUNDED BY A SECOND WIDER AND IRREGULARLY SHAPED OUTER CIRCLE THAT CONTAINS A BLUNT POINT AT THE TOP.

THE WORDING "DEVIALET" HAS NO MEANING IN A FOREIGN LANGUAGE.

FOR APPARATUS FOR RECORDING, TRANSMITTING, REPRODUCING OR PROCESSING SOUND OR IMAGES; BLANK MAGNETIC RECORDING MEDIA; BLANK ACOUSTIC DISKS AND BLANK OPTICAL DISKS; AMPLIFIERS; RADIOS; RECORD PLAYERS; COMPACT DISK PLAYERS; DVD PLAYERS; HI-FI EQUIPMENT, NAMELY, SOUND MIXERS AND EQUALIZERS; HI-FI SOUND SYSTEMS COMPRISED OF STEREO, CD PLAYERS, LOUDSPEAKERS, AUDIO SPEAKERS, LIQUID CRYSTAL DISPLAYS AND HEADPHONES; LOUDSPEAKERS; TELEVISIONS; VIDEO PROJECTORS; CONNECTION STATIONS FOR DIGITAL PLAYERS, NAMELY, SPEAKERS FOR DIGITAL PLAYERS, DOCKING STATIONS FOR DIGITAL PLAYERS (U.S. CLS. 21, 23, 26, 36 AND 38).

NAPOLEON SHARMA, EXAMINING ATTORNEY

**CLASS 9—(Continued).**

SN 79-083,172. FCI, FRANCE, FILED 4-16-2010.

# Minitek127

THE MARK CONSISTS OF STANDARD CHARACTERS WITHOUT CLAIM TO ANY PARTICULAR FONT, STYLE, SIZE, OR COLOR.

PRIORITY DATE OF 10-16-2009 IS CLAIMED.

OWNER OF INTERNATIONAL REGISTRATION 1040436 DATED 4-16-2010, EXPIRES 4-16-2020.

FOR ELECTRICAL, ELECTRONIC, OPTICAL AND ELECTRO-OPTICAL CONNECTORS; COMPONENTS THEREOF, NAMELY, CONTACT TERMINALS, INSULATORS AND HOUSINGS SPECIFICALLY DESIGNED FOR USE WITH ELECTRICAL, ELECTRONIC, OPTICAL AND ELECTRO-OPTICAL CONNECTORS; ELECTRICAL, ELECTRONIC, OPTICAL AND ELECTRO-OPTICAL CONNECTION AND INTERCONNECTION DEVICES OF IN ALL FORMS, NAMELY, MICRO-CONNECTOR DEVICES FOR USE WITH COMPUTERS IN THE NATURE OF CONNECTORS FOR ELECTRONIC CIRCUITS; ELECTRICAL CONTACTS, PINS AND CONTACT SOCKETS; CONNECTORS FOR CHIP CARDS AND FLEXIBLE PRINTED CIRCUITS FOR SEMICONDUCTORS (U.S. CLS. 21, 23, 26, 36 AND 38).

MICHAEL TANNER, EXAMINING ATTORNEY

---

SN 79-083,177. ABB AB, VASTERÅS, SWEDEN, FILED 5-5-2010.

# wiMon

THE MARK CONSISTS OF STANDARD CHARACTERS WITHOUT CLAIM TO ANY PARTICULAR FONT, STYLE, SIZE, OR COLOR.

PRIORITY DATE OF 12-7-2009 IS CLAIMED.

OWNER OF INTERNATIONAL REGISTRATION 1040445 DATED 5-5-2010, EXPIRES 5-5-2020.

FOR ELECTRONIC WIRELESS VIBRATION SENSORS AND TEMPERATURE SENSORS FOR USE WITH ROTATING MACHINERY AND IN HAZARDOUS AREAS (U.S. CLS. 21, 23, 26, 36 AND 38).

NAPOLEON SHARMA, EXAMINING ATTORNEY

**CLASS 9—(Continued).**

SN 79-083,534. VOTO COMMUNICATION CO.,LTD, CHINA, FILED 5-10-2010.

# VOTO

OWNER OF INTERNATIONAL REGISTRATION 1041391 DATED 5-10-2010, EXPIRES 5-10-2020.

THE MARK CONSISTS OF THE LETTERS "VOTO".

THE WORDING "VOTO" HAS NO MEANING IN A FOREIGN LANGUAGE.

FOR TELEPHONE RECEIVERS; TELEPHONE APPARATUS; TELEGRAPHS; VIDEO TELEPHONES; PORTABLE TELEPHONES; WALKIE-TALKIES; HANDS FREE KITS FOR PHONES; ELECTRONIC AND OPTICAL COMMUNICATION INSTRUMENTS AND COMPONENTS, NAMELY, OPTICAL RECEIVERS, OPTICAL TRANSMITTERS, OPTICAL DATA LINKS, CABLE TELEVISION TRANSMITTERS; AUTOMATIC TELEPHONE EXCHANGES; NETWORK COMMUNICATION EQUIPMENT, NAMELY, NETWORK ROUTERS, NETWORK SERVERS (U.S. CLS. 21, 23, 26, 36 AND 38).

LINDA MICKLEBURGH, EXAMINING ATTORNEY

SN 79-084,302. RIPASSO ENERGY AB, SWEDEN, FILED 4-22-2010.

# RIPASSO ENERGY

THE MARK CONSISTS OF STANDARD CHARACTERS WITHOUT CLAIM TO ANY PARTICULAR FONT, STYLE, SIZE, OR COLOR.

PRIORITY DATE OF 4-15-2010 IS CLAIMED.

OWNER OF INTERNATIONAL REGISTRATION 1043385 DATED 4-22-2010, EXPIRES 4-22-2020.

NO CLAIM IS MADE TO THE EXCLUSIVE RIGHT TO USE "ENERGY", APART FROM THE MARK AS SHOWN.

THE WORD(S) "RIPASSO" HAS NO MEANING IN A FOREIGN LANGUAGE.

FOR ELECTRICITY GENERATING APPARATUS UTILIZING SOLAR POWER, NAMELY, SOLAR THERMAL POWER PLANTS; SOLAR COLLECTOR FOR ELECTRICITY GENERATION; SOLAR BATTERY CHARGERS; APPARATUS AND INSTRUMENTS FOR CONDUCTING, SWITCHING, TRANSFORMING, ACCUMULATING, REGULATING OR CONTROLLING ELECTRICITY, PRODUCTION AND DISTRIBUTION OF ELECTRICITY, NAMELY, ELECTRICITY DISTRIBUTION NETS IN THE NATURE OF ELECTRICAL POWER DISTRIBUTION UNITS; APPARATUS AND INSTRUMENTS FOR SUPERVISION, REMOTE CONTROL, CONTROL AND MEASUREMENT OF ELECTRICITY AND ENERGY CONSUMPTION AND FOR OPERATING POWER STATIONS, NAMELY, MONITORING AND SUPERVISION SOFTWARE, ELECTRICAL CURRENT AND VOLTAGE SENSORS, THERMAL AND PRESSURE SENSORS; ELECTRICITY CABLES, ELECTRIC CONNECTORS AND ELECTRIC TRANSFORMERS FOR DISTRIBUTION OF ELECTRICITY AND ENERGY FOR USE IN OPERATING ELECTRICITY AND ENERGY IN POWER PLANTS (U.S. CLS. 21, 23, 26, 36 AND 38).

FLORENTINA BLANDU, EXAMINING ATTORNEY

**CLASS 9—(Continued).**

SN 79-084,446. "FANTY" COMPANY LIMITED, RUSSIAN FED., FILED 4-2-2010.

# FANTY

THE MARK CONSISTS OF STANDARD CHARACTERS WITHOUT CLAIM TO ANY PARTICULAR FONT, STYLE, SIZE, OR COLOR.

OWNER OF INTERNATIONAL REGISTRATION 1043657 DATED 4-2-2010, EXPIRES 4-2-2020.

THE WORDING "FANTY" HAS NO MEANING IN A FOREIGN LANGUAGE.

FOR VIDEO CASSETTES WITH RECORDED ANIMATED CARTOONS; HOLOGRAMS APPARATUS; PHOTOGRAPHIC SLIDES; PRE-RECORDED FLOPPY DISKS FOR USE IN THE FIELD OF COMPUTER GAMES; PRE-RECORDED SOUND DISC CONTAINING THE MUSIC; PRE-RECORDED MAGNETIC DISKS FOR USE IN THE FIELD OF COMPUTER GAMES; PRE-RECORDED OPTICAL DISCS FOR USE IN THE FIELD OF COMPUTER GAMES; INTERACTIVE DOWNLOADABLE COMPUTER GAMES PROGRAMMES FOR USE BY ONE OR SEVERAL PLAYERS; DOWNLOADABLE INTERACTIVE VIRTUAL REALITY VIDEO GAME SOFTWARE AND PROGRAMMES; MAGNETIC IDENTITY CARDS; VIDEO GAME CARTRIDGES; PRE-RECORDED AUDIO-VIDEO COMPACT DISCS FOR USE IN THE FIELD OF COMPUTER GAMES; MULTIMEDIA SOFTWARE RECORDED IN CD-ROMS FOR THE USE OF THE FIELD OF COMPUTER GAMES; COMPUTER GAME SOFTWARE ALLOWING PLAYERS TO PLAY GAMES WITH OTHER PLAYERS IN COMMUNICATION NETWORKS; INTERACTIVE COMPUTER GAME SOFTWARE; BLANK MAGNETIC SOUND RECORDING CARRIERS; BLANK MAGNETIC DATA STORAGE MEDIA; BLANK OPTICAL DATA STORAGE MEDIA; COMPUTER SOFTWARE FOR GAMES WITH VIRTUAL REALITY; DOWNLOADABLE COMPUTER PROGRAMMES FOR THE USE OF THE FIELD OF COMPUTER GAMES; COMPUTER GAME PROGRAMMES; RECORDED COMPUTER PROGRAMMES FOR THE USE OF THE FIELD OF COMPUTER GAMES; COMPUTER PROGRAMMES FOR DOWNLOADING MELODIES AND RINGTONES FOR MOBILE PHONES; DOWNLOADABLE PUBLICATION, NAMELY, MAGAZINES, NEWSLETTERS IN THE FIELD OF COMPUTER GAMES; APPARATUS FOR GAMES ADAPTED FOR USE WITH AN EXTERNAL DISPLAY SCREEN OR MONITOR; AMUSEMENT APPARATUS ADAPTED FOR USE WITH AN EXTERNAL DISPLAY SCREEN OR MONITOR; ELECTRONIC APPARATUS FOR GAMES ADAPTED FOR USE WITH AN EXTERNAL DISPLAY SCREEN OR MONITOR (U.S. CLS. 21, 23, 26, 36 AND 38).

KRISTINA MORRIS, EXAMINING ATTORNEY

SN 79-084,589. NANOFOCUS AG, FED REP GERMANY, FILED 5-14-2010.

# MICROSPRINT

THE MARK CONSISTS OF STANDARD CHARACTERS WITHOUT CLAIM TO ANY PARTICULAR FONT, STYLE, SIZE, OR COLOR.

PRIORITY DATE OF 11-24-2009 IS CLAIMED.

OWNER OF INTERNATIONAL REGISTRATION 1044028 DATED 5-14-2010, EXPIRES 5-14-2020.

FOR OPTOELECTRONIC APPARATUS FOR SURFACE MEASURING IN THE NATURE OF CONTACT FREE WORKING INSTRUMENTS FOR SURFACE MEASURING WITH A THREE DIMENSIONAL RECORDING SENSOR ON THE BASIS OF A CONFOCAL MICROSCOPE (U.S. CLS. 21, 23, 26, 36 AND 38).

TARAH HARDY, EXAMINING ATTORNEY

**CLASS 9—(Continued).**

SN 79-087,973. HYPEX ELECTRONICS B.V., GRONINGEN, NETHERLANDS, FILED 9-2-2010.



PRIORITY DATE OF 3-3-2010 IS CLAIMED.  
OWNER OF INTERNATIONAL REGISTRATION 1052808  
DATED 9-2-2010, EXPIRES 9-2-2020.

NO CLAIM IS MADE TO THE EXCLUSIVE RIGHT TO USE "AUDIO POWER CONVERSION", APART FROM THE MARK AS SHOWN.

THE COLOR(S) ORANGE, WHITE AND BLACK IS/ARE CLAIMED AS A FEATURE OF THE MARK.

THE MARK CONSISTS OF THE WORDING "NCORE AUDIO POWER CONVERSION" WHERE THE "N" IS WHITE AND LOCATED IN THE MIDDLE OF AN INCOMPLETE ORANGE CIRCLE, AND ALL THE OTHER LETTERING IS BLACK.

FOR AUDIO EQUIPMENT, NAMELY, AMPLIFIERS AND AUDIO ELECTRONIC COMPONENTS IN THE NATURE OF LOUD SPEAKER SYSTEMS; EQUIPMENT FOR THE TRANSFER AND REPRODUCTION OF SOUND, NAMELY, SWITCH MODE POWER SUPPLIES, PLATE AMPLIFIERS, PRINTED CIRCUIT BOARDS FOR AMPLIFIER MODULES; EQUIPMENT FOR PROCESSING DATA, NAMELY, PRINTED CIRCUIT BOARDS FOR AMPLIFIER MODULES; TRANSFORMERS, AMPLIFIER MODULES AND POWER SUPPLIES (U.S. CLS. 21, 23, 26, 36 AND 38).

AISHA CLARKE, EXAMINING ATTORNEY

**CLASS 9—(Continued).**

SN 79-088,739. VOICESERVE LIMITED, UNITED KINGDOM, FILED 7-2-2010.



PRIORITY DATE OF 2-25-2010 IS CLAIMED.  
OWNER OF INTERNATIONAL REGISTRATION 1054988  
DATED 7-2-2010, EXPIRES 7-2-2020.

NO CLAIM IS MADE TO THE EXCLUSIVE RIGHT TO USE "VOIP SWITCH", APART FROM THE MARK AS SHOWN.

THE COLOR(S) LIGHT BLUE, DARK BLUE, AND GRAY IS/ARE CLAIMED AS A FEATURE OF THE MARK.

THE MARK CONSISTS OF THE WORDING "VOIP SWITCH" IN GRAY, TO THE RIGHT OF A RECTANGLE WITH A LIGHT BLUE UPPER HALF, A DARK BLUE LOWER HALF, AND A WAVY LINE SEPARATING THE HALVES.

FOR COMPUTER SOFTWARE FOR VOICE-OVER INTERNET PROTOCOL TELEPHONY; SOFTWARE FOR MOBILE DEVICES FOR VOICE-OVER INTERNET PROTOCOL TELEPHONY; SOFTWARE PLATFORMS FOR MOBILE DEVICES, NAMELY, SOFTWARE FOR VOICE-OVER INTERNET PROTOCOL TELEPHONY; SOFTWARE FOR VOICE-OVER INTERNET PROTOCOL TELEPHONY; SWITCHING SOFTWARE, NAMELY, TELEPHONE SWITCHING SOFTWARE FOR VOICE-OVER INTERNET PROTOCOL TELEPHONY; BILLING SOLUTION SOFTWARE, NAMELY, SOFTWARE FOR ACCEPTING ELECTRONIC BILL PAYMENTS, SOFTWARE FOR MANAGING CUSTOMER BILLING; INTERNET INTERFACE SOFTWARE, NAMELY, TELEPHONY SOFTWARE FOR OPERATING A PRIVATE BRANCH EXCHANGE VIA AN INTERNET CONNECTION; SOFTWARE FOR RECORDING, TRANSMITTING, REPRODUCING AND RECEIVING SOUND, IMAGES OR DATA OVER THE INTERNET; TELECOMMUNICATIONS SOFTWARE FOR RECORDING, TRANSMITTING, REPRODUCING AND RECEIVING SOUND, IMAGES OR DATA (U.S. CLS. 21, 23, 26, 36 AND 38).

LIEF MARTIN, EXAMINING ATTORNEY

SN 79-089,154. SPEMOT AG, SWITZERLAND, FILED 10-4-2010.

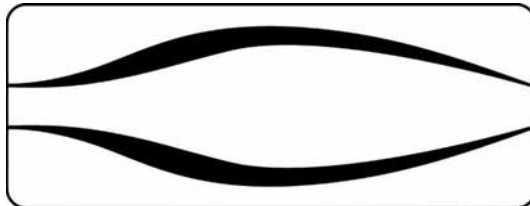

PRIORITY DATE OF 4-8-2010 IS CLAIMED.  
OWNER OF INTERNATIONAL REGISTRATION 1056149  
DATED 10-4-2010, EXPIRES 10-4-2020.

THE MARK CONSISTS OF TWO CURVED LINES, HORIZONTALLY SYMMETRICAL, WITH THE TOP CURVE CURVING UPWARDLY IN THE MIDDLE, AND THE BOTTOM CURVE CURVING DOWNWARDLY IN THE MIDDLE AND WITH THE CURVES SURROUNDED BY A RECTANGLE WITH CURVED CORNERS.

FOR APPARATUS FOR THE RECORDING, TRANSMISSION AND REPRODUCTION OF SOUND AND IMAGES; APPARATUS FOR THE RECORDING, TRANSMISSION AND REPRODUCTION OF SOUND; AND APPARATUS FOR THE RECORDING, TRANSMISSION AND REPRODUCTION OF IMAGES (U.S. CLS. 21, 23, 26, 36 AND 38).

JASON BLAIR, EXAMINING ATTORNEY



**CLASS 9—(Continued).**

SN 79-089,880. ELEMENTAR ANALYSENSYSTEME GMBH, FED REP GERMANY, FILED 9-15-2010.

# elementargroup

THE MARK CONSISTS OF STANDARD CHARACTERS WITHOUT CLAIM TO ANY PARTICULAR FONT, STYLE, SIZE, OR COLOR.

OWNER OF INTERNATIONAL REGISTRATION 1058063 DATED 9-15-2010, EXPIRES 9-15-2020.

THE ENGLISH TRANSLATION OF "ELEMENTAR" IN THE MARK IS ELEMENTARY.

FOR SCIENTIFIC APPARATUS AND INSTRUMENTS, NAMELY, MEASURING APPARATUS FOR CHEMICAL ANALYSIS (U.S. CLS. 21, 23, 26, 36 AND 38).

LESLIE RICHARDS, EXAMINING ATTORNEY

---

SN 85-001,294. GLOBAL ALERTS, LLC, DBA EARTH911, SCOTTSDALE, AZ. FILED 3-29-2010.

# IRECYCLE

THE MARK CONSISTS OF STANDARD CHARACTERS WITHOUT CLAIM TO ANY PARTICULAR FONT, STYLE, SIZE, OR COLOR.

FOR DOWNLOADABLE SOFTWARE IN THE NATURE OF A MOBILE APPLICATION FOR LOCATING RECYCLING CENTERS, LOCAL EVENTS, AND RECYCLING INFORMATION (U.S. CLS. 21, 23, 26, 36 AND 38).

FIRST USE 5-8-2009; IN COMMERCE 5-8-2009.

FONG HSU, EXAMINING ATTORNEY

---

SN 85-001,618. DECHIARO, JOHN P., DBA THE CARLOW CHOIR, PINEVILLE, LA. FILED 3-30-2010.

# The Carlow Choir

THE MARK CONSISTS OF STANDARD CHARACTERS WITHOUT CLAIM TO ANY PARTICULAR FONT, STYLE, SIZE, OR COLOR.

NO CLAIM IS MADE TO THE EXCLUSIVE RIGHT TO USE "CHOIR", APART FROM THE MARK AS SHOWN.

FOR AUDIO AND VIDEO RECORDINGS FEATURING MUSIC AND ARTISTIC PERFORMANCES (U.S. CLS. 21, 23, 26, 36 AND 38).

FIRST USE 2-21-2008; IN COMMERCE 9-1-2009.

REGINA DRUMMOND, EXAMINING ATTORNEY

**CLASS 9—(Continued).**

SN 85-002,620. CANYON FLIGHT TRADING COMPANY, KIRKLAND, WA. FILED 3-31-2010.

# WINGS OVER GRAND CANYON

THE MARK CONSISTS OF STANDARD CHARACTERS WITHOUT CLAIM TO ANY PARTICULAR FONT, STYLE, SIZE, OR COLOR.

NO CLAIM IS MADE TO THE EXCLUSIVE RIGHT TO USE "GRAND CANYON", APART FROM THE MARK AS SHOWN.

FOR PRERECORDED DVDS FEATURING TOURS OF THE GRAND CANYON, EMPHASIS ON THE COMPLETE 1700-MILE STRING OF PARKS THAT LEAD TO THE GRAND CANYON FOR SCHOOLS, LIBRARIES AND CONSUMERS (U.S. CLS. 21, 23, 26, 36 AND 38).

JOSETTE BEVERLY, EXAMINING ATTORNEY

---

SN 85-004,084. CAPITAL TECHNOLOGY INFORMATION SERVICES, INC., ROCKVILLE, MD. FILED 4-1-2010.

# HEALTHYME

THE MARK CONSISTS OF STANDARD CHARACTERS WITHOUT CLAIM TO ANY PARTICULAR FONT, STYLE, SIZE, OR COLOR.

FOR COMPUTER SOFTWARE FOR USE IN STORING A USER'S HEALTHCARE RECORDS, ALLOWING USERS TO ACCESS THEIR HEALTHCARE RECORDS IN REAL-TIME AND SHARE THEM WITH DOCTORS AND OTHER HEALTHCARE PROVIDERS, TRACKING AND MONITORING A USER'S HEALTH STATUS, MEDICAL CONDITIONS, AND MEDICAL CONTACT INFORMATION, TRACKING A USER'S PAST MEDICAL PROCEDURES, PROVIDING THE RESULTS OF MEDICAL TESTS, MANAGING THE DOSAGE, STRENGTH, AND FREQUENCY OF A USER'S PRESCRIPTION AND OVER-THE-COUNTER MEDICATIONS, SCHEDULING AND MANAGING A USER'S MEDICAL APPOINTMENTS, STORING A USER'S IMMUNIZATION RECORDS, TRACKING A USER'S ALLERGIES, AND MONITORING A USER'S DIET, CALORIC INTAKE, AND EXERCISE PROGRAMS, PROVIDING USERS WITH PICTORIAL AND GRAPHIC REPRESENTATIONS OF MEDICAL CONDITIONS, MEDICATIONS, AND PRESCRIPTIONS, TEST RESULTS, AND MEDICAL CONTACTS, PROVIDING MAPS TO HEALTHCARE PROVIDERS AND INSTITUTIONS, PROVIDING USERS ACCESS TO RSS FEEDS, AND PROVIDING USERS WITH HEALTH RELATED ALERTS, REMINDERS, AND NOTIFICATIONS (U.S. CLS. 21, 23, 26, 36 AND 38).

RUDY R. SINGLETON, EXAMINING ATTORNEY

**CLASS 9—(Continued).**

SN 85-004,928. BIOTIX INC, SAN DIEGO, CA. FILED 4-2-2010.

**DELTA FILTER**

THE MARK CONSISTS OF STANDARD CHARACTERS WITHOUT CLAIM TO ANY PARTICULAR FONT, STYLE, SIZE, OR COLOR.

NO CLAIM IS MADE TO THE EXCLUSIVE RIGHT TO USE "FILTER", APART FROM THE MARK AS SHOWN.

FOR LABORATORY CONSUMABLES, NAMELY, FILTERED PIPETTE TIPS (U.S. CLS. 21, 23, 26, 36 AND 38).  
AMY HELLA, EXAMINING ATTORNEY

**CLASS 9—(Continued).**

SN 85-006,907. SUMMIT ENTERTAINMENT, LLC, SANTA MONICA, CA. FILED 4-6-2010.



THE MARK CONSISTS OF A CIRCULAR TRIBAL TATTOO DESIGN DEPICTING TWO WOLVES FACING ONE ANOTHER IN A HOWLING POSITION, SET AMONGST NUMEROUS INTERWOVEN LINES AND SHAPES AND ALL WITHIN THE CIRCLE.

FOR (BASED ON USE IN COMMERCE) DECORATIVE MAGNETS AND DECORATIVE MAGNETS SOLD IN SHEETS (BASED ON INTENT TO USE) BACKPACKS ADAPTED FOR HOLDING COMPUTERS; CAMERA CASES; CASES FOR MOBILE PHONES; CASES FOR PDAS; CELL PHONES; COMPUTER GAMES, NAMELY, COMPUTER GAME CARTRIDGES, DISCS AND SOFTWARE; COMPUTER STORAGE DEVICES, NAMELY, FLASH DRIVES; COVERS FOR CELL PHONES, PORTABLE MUSIC PLAYERS, LAPTOP COMPUTERS, PDAS, AND HANDHELD GAMING DEVICES; DECORATIVE CHARMS FOR CELL PHONES; DIGITAL FILES DOWNLOADABLE FROM THE INTERNET FEATURING MUSIC, AUDIO/VISUAL RECORDINGS, AND LITERARY CONTENT; DIGITAL TRADING CARDS IN THE FORM OF CDS; DISPOSABLE CAMERAS; ELECTRIC DOOR BELLS; ELECTRONIC DIARIES; EYEGLASSES AND EYEGLASS CASES; HEADPHONES AND EARPHONES; JUKE BOXES; LAPTOP CARRYING CASES; LIGHTED DISPLAYS FOR OUTDOOR USE IN THE NATURE OF LED DISPLAYS; MOTION PICTURE FILMS IN THE FIELDS OF DRAMA AND ROMANCE; MOUSEPADS; MUSICAL SOUND RECORDINGS; NEON SIGNS; PRE-RECORDED DVDS, VIDEOTAPES, AND OTHER AUDIOVISUAL RECORDINGS FEATURING MOTION PICTURES, TELEVISION PROGRAMS AND DOCUMENTARIES; SLOT MACHINES; SUNGLASSES AND SUNGLASS CASES; SWITCH PLATE COVERS; TAPE MEASURES; TRADING CARDS IN THE FORM OF CDS; VIDEO GAMES, NAMELY, VIDEO GAME CARTRIDGES, DISCS AND SOFTWARE; AND DOWNLOADABLE SOFTWARE THAT PROVIDES ACCESS TO MOVIE AND ENTERTAINMENT-RELATED CONTENT AND ALLOWS USERS TO SOCIALIZE AND INTERACT WITH OTHER USERS (U.S. CLS. 21, 23, 26, 36 AND 38).

FIRST USE 11-0-2009; IN COMMERCE 11-0-2009.  
TRACY FLETCHER, EXAMINING ATTORNEY

SN 85-005,172. VISUALSONICS INC., TORONTO, ONTARIO, CANADA, FILED 4-2-2010.

**MICROSCAN**

THE MARK CONSISTS OF STANDARD CHARACTERS WITHOUT CLAIM TO ANY PARTICULAR FONT, STYLE, SIZE, OR COLOR.

FOR SCIENTIFIC APPARATUS AND INSTRUMENTS, NAMELY, ULTRASONIC TRANSDUCERS, ULTRA-HIGH FREQUENCY TRANSDUCERS, AND SOLID-STATE TRANSDUCERS (U.S. CLS. 21, 23, 26, 36 AND 38).  
FIRST USE 9-0-2008; IN COMMERCE 9-0-2008.

STEVEN R. FINE, EXAMINING ATTORNEY

**CLASS 9—(Continued).**

SN 85-006,943. EVEX INC., PRINCETON, NJ. FILED 4-6-2010.

**EVEXIUM**

THE MARK CONSISTS OF STANDARD CHARACTERS WITHOUT CLAIM TO ANY PARTICULAR FONT, STYLE, SIZE, OR COLOR.

FOR LABORATORY EQUIPMENT, INSTRUMENTATION AND SUPPLIES FOR USE IN THE BIOMEDICAL, INDUSTRIAL AND EDUCATIONAL FIELDS, NAMELY, SCIENTIFIC ANALYTICAL DEVICES IN THE NATURE OF ELECTRON MICROSCOPES, X-RAY SPECTROMETERS, AND SPECTRAL ANALYSIS SYSTEMS (U.S. CLS. 21, 23, 26, 36 AND 38).

FIRST USE 1-10-2011; IN COMMERCE 1-10-2011.  
ALLISON HOLTZ, EXAMINING ATTORNEY

---

SN 85-006,976. FISHMAN CORPORATION, HOPKINTON, MA. FILED 4-6-2010.

**GENIUS**

THE MARK CONSISTS OF STANDARD CHARACTERS WITHOUT CLAIM TO ANY PARTICULAR FONT, STYLE, SIZE, OR COLOR.

FOR INDUSTRIAL SYRINGES FOR DISPENSING INDUSTRIAL FLUIDS IN PRE-MEASURED AMOUNTS, AND COMPONENTS FOR INDUSTRIAL SYRINGES, NAMELY BARRELS, PISTONS, AND NEEDLE TIPS (U.S. CLS. 21, 23, 26, 36 AND 38).

STEVEN R. FINE, EXAMINING ATTORNEY

---

SN 85-007,898. BEYONDTRUST SOFTWARE, INC., AGOURA HILLS, CA. FILED 4-6-2010.

**POWERBROKER MANAGEMENT  
CONSOLE**

THE MARK CONSISTS OF STANDARD CHARACTERS WITHOUT CLAIM TO ANY PARTICULAR FONT, STYLE, SIZE, OR COLOR.

OWNER OF U.S. REG. NOS. 2,139,979 AND 3,435,338.  
NO CLAIM IS MADE TO THE EXCLUSIVE RIGHT TO USE "MANAGEMENT CONSOLE", APART FROM THE MARK AS SHOWN.

FOR COMPUTER SOFTWARE PROGRAMS FOR THE CENTRALIZED MANAGEMENT AND REPORTING OF POLICY MANAGEMENT IN THE FIELD(S) OF INFORMATION TECHNOLOGY, SECURITY AND IDENTITY MANAGEMENT (U.S. CLS. 21, 23, 26, 36 AND 38).

EDWARD FENNESSY, EXAMINING ATTORNEY

**CLASS 9—(Continued).**

SN 85-007,899. BEYONDTRUST SOFTWARE, INC., AGOURA HILLS, CA. FILED 4-6-2010.

**powerbroker**   
Management Console

OWNER OF U.S. REG. NOS. 2,139,979 AND 3,435,338.

NO CLAIM IS MADE TO THE EXCLUSIVE RIGHT TO USE "MANAGEMENT CONSOLE", APART FROM THE MARK AS SHOWN.

THE MARK CONSISTS OF A STYLISTIC DESIGN OF AN INVERTED LETTER "Q" CONTAINING STRIPES AS ACCENTS WITH AN INVERTED TRIANGLE IN ITS CENTER AND THE WORDS "POWERBROKER MANAGEMENT CONSOLE" LOCATED TO THE LEFT OF THE DESIGN.

FOR COMPUTER SOFTWARE PROGRAMS FOR THE CENTRALIZED MANAGEMENT AND REPORTING OF POLICY MANAGEMENT IN THE FIELD(S) OF INFORMATION TECHNOLOGY, SECURITY AND IDENTITY MANAGEMENT (U.S. CLS. 21, 23, 26, 36 AND 38).

EDWARD FENNESSY, EXAMINING ATTORNEY

---

SN 85-011,446. RECORD MY DOCTOR, INC., WARREN, OH. FILED 4-12-2010.

**RECORD MY DOCTOR**

THE MARK CONSISTS OF STANDARD CHARACTERS WITHOUT CLAIM TO ANY PARTICULAR FONT, STYLE, SIZE, OR COLOR.

FOR BATTERY OPERATED PORTABLE ELECTRONIC DEVICE IN THE NATURE OF AN AUDIO RECORDER WHICH RECORDS AUDIO TO BE PLAYED BACK ONLY IN CONJUNCTION WITH MEDICAL INSTRUCTIONS AND QUESTIONS (U.S. CLS. 21, 23, 26, 36 AND 38).

ALICE BENMAMAN, EXAMINING ATTORNEY

---

SN 85-011,790. FISHMAN CORPORATION, HOPKINTON, MA. FILED 4-12-2010.

**ProcessControl<sup>2</sup>**

NO CLAIM IS MADE TO THE EXCLUSIVE RIGHT TO USE "PROCESS CONTROL", APART FROM THE MARK AS SHOWN.

THE MARK CONSISTS OF THE WORD "PROCESSCONTROL" FOLLOWED BY A SUPERSCRIPIT NUMBER "2".

FOR INDUSTRIAL FLUID DISPENSER SOFTWARE, NAMELY, SOFTWARE FOR RUNNING A MOTOR TO POSITION A DISPENSER NEEDLE TIP AND TO DISPENSE AN AMOUNT OF FLUID (U.S. CLS. 21, 23, 26, 36 AND 38).

STEVEN R. FINE, EXAMINING ATTORNEY

**CLASS 9—(Continued).**

SN 85-012,385. FISHMAN CORPORATION, HOPKINTON, MA. FILED 4-13-2010.

**CLASS 9—(Continued).**

SN 85-016,019. SABETA IP, INC., TORONTO, CANADA, FILED 4-16-2010.

# LDS9000

THE MARK CONSISTS OF STANDARD CHARACTERS WITHOUT CLAIM TO ANY PARTICULAR FONT, STYLE, SIZE, OR COLOR.

FOR AUTOMATIC FLUID DISPENSERS FOR DISPENSING INDUSTRIAL FLUIDS IN PRE-MEASURED AMOUNTS, COMPRISED OF CONTROLLERS, SYRINGES AND SYRINGE COMPONENTS, NAMELY, BARRELS, PISTONS AND NEEDLE TIPS (U.S. CLS. 21, 23, 26, 36 AND 38).

FIRST USE 1-1-2000; IN COMMERCE 1-1-2000.  
STEVEN R. FINE, EXAMINING ATTORNEY

# RIFFED

---

SN 85-015,023. SCHLUMBERGER TECHNOLOGY CORPORATION, HOUSTON, TX. FILED 4-15-2010.

# TECHLOG

THE MARK CONSISTS OF STANDARD CHARACTERS WITHOUT CLAIM TO ANY PARTICULAR FONT, STYLE, SIZE, OR COLOR.

FOR SOFTWARE FOR DATA MANAGEMENT, ANALYSIS AND MODELING OF SUBSURFACE GEOLOGICAL FORMATIONS AND STRUCTURES, AND ENABLING REAL-TIME DATA ACCESS FOR PETROPHYSICS, GEOLOGY, DRILLING, RESERVOIR AND PRODUCTION ENGINEERING, AND GEOPHYSICS IN THE FIELD OF OIL AND GAS EXPLORATION AND PRODUCTION (U.S. CLS. 21, 23, 26, 36 AND 38).

FIRST USE 0-0-2003; IN COMMERCE 0-0-2003.  
JULIE VEPPUMTHARA, EXAMINING ATTORNEY

THE MARK CONSISTS OF STANDARD CHARACTERS WITHOUT CLAIM TO ANY PARTICULAR FONT, STYLE, SIZE, OR COLOR.

FOR RADIO FREQUENCY IDENTIFICATION TAGS, WIRELESS SENSORS, AND READERS; RADIO FREQUENCY IDENTIFICATION SYSTEMS, NAMELY, TAGS, READERS, ENCODERS, TRANSPONDERS, ANTENNAS, AND SOFTWARE FOR USE IN CREATING, READING AND EXTRACTING DATA FROM, AND CLASSIFYING AND TRACKING DATA FROM RADIO FREQUENCY IDENTIFICATION TAGS AND WIRELESS SENSORS AND READERS; TRANSPONDERS; ANTENNAS, RADIO FREQUENCY IDENTIFICATION TRACKING SYSTEMS AND SENSOR-BASED TRACKING SYSTEMS BOTH COMPRISED OF RADIO FREQUENCY IDENTIFICATION TAGS, WIRELESS SENSORS, AND READERS (U.S. CLS. 21, 23, 26, 36 AND 38).

TARAH HARDY, EXAMINING ATTORNEY

**CLASS 9—(Continued).**

SN 85-016,104. LIGHTSQUARED LP, RESTON, VA. FILED 4-16-2010.

**CLASS 9—(Continued).**

SN 85-016,135. LIGHTSQUARED, LP, RESTON, VA. FILED 4-16-2010.



LIGHTSQUARED

THE MARK CONSISTS OF STYLIZED WORDING, "LIGHTSQUARED" IN ALL CAPS, WITH THE LETTER, "S" IN "SQUARED" THE LARGEST OF ALL THE LETTERING, WITH A DESIGN OF A SHADED BOX WITH UN-SHADED LINES ON THE EDGES AND AN UN-SHADED REFLECTIVE ORB ON THE CORNER OF THE BOX.

FOR TELECOMMUNICATIONS EQUIPMENT, NAMELY, CELLULAR TELEPHONES; BROADBAND WIRELESS COMMUNICATIONS EQUIPMENT, NAMELY, TELECOMMUNICATIONS BASE STATION EQUIPMENT FOR CELLULAR AND FIXED NETWORKING AND COMMUNICATIONS APPLICATIONS; NETWORK MANAGEMENT SOFTWARE FOR VOICE AND DATA NETWORKS; GPS NAVIGATION DEVICES AND COMPONENTS USED THEREWITH; NAVIGATION AND POSITIONING EQUIPMENT, NAMELY, SATELLITE AERIALS, DISHES AND RADIOS; COMPUTER SOFTWARE FOR USE IN TRANSMITTING DATA AND/OR VOICE OVER A WIRELESS OR WIRELINE NETWORK; HARDWARE AND FIRMWARE FOR USE IN TRANSMITTING DATA AND/OR VOICE OVER A WIRELESS OR WIRELINE NETWORK; ELECTRONIC DEVICES AND SOFTWARE FOR USE IN TRANSMITTING DATA AND/OR VOICE OVER A WIRELESS OR WIRELINE NETWORK; WIRELESS DATA MODEMS, PORTABLE NETWORK ROUTERS, HAND-HELD WIRELESS MODEMS AND NETWORK ROUTERS, PC WIRELESS CARDS, AND MOBILE COMPUTING AND OPERATING PLATFORMS CONSISTING OF WIRELESS GATEWAYS USED FOR LINKING TERMINALS VIA A COMPUTER NETWORK, RADIO OR FIXED LINE NETWORKS; WIRELESS EMBEDDED MODEM MODULES; COMPUTER SOFTWARE FOR USE IN WIRELESS MODEMS, PORTABLE ROUTERS, AND WIRELESS GATEWAYS FOR LINKING TERMINALS VIA COMPUTER NETWORK, RADIO OR FIXED LINE NETWORKS; WIRELESS COMMUNICATION DEVICES FOR PROVIDING VOICE, DATA, OR IMAGE TRANSMISSION IN WIRELESS COMMUNICATION SERVICES TO ONE OR MORE DEVICES; PORTABLE COMPUTER NETWORK ROUTERS, HAND-HELD WIRELESS COMPUTER NETWORK ROUTERS (U.S. CLS. 21, 23, 26, 36 AND 38).

ODESSA BIBBINS, EXAMINING ATTORNEY

THE MARK CONSISTS OF STANDARD CHARACTERS WITHOUT CLAIM TO ANY PARTICULAR FONT, STYLE, SIZE, OR COLOR.

FOR TELECOMMUNICATIONS EQUIPMENT, NAMELY, CELLULAR TELEPHONES; BROADBAND WIRELESS COMMUNICATIONS EQUIPMENT, NAMELY, TELECOMMUNICATIONS BASE STATION EQUIPMENT FOR CELLULAR AND FIXED NETWORKING AND COMMUNICATIONS APPLICATIONS; NETWORK MANAGEMENT SOFTWARE FOR VOICE AND DATA NETWORKS; GPS NAVIGATION DEVICES AND COMPONENTS USED THEREWITH; NAVIGATION AND POSITIONING EQUIPMENT, NAMELY, SATELLITE AERIALS, DISHES AND RADIOS; COMPUTER SOFTWARE FOR USE IN TRANSMITTING DATA AND/OR VOICE OVER A WIRELESS OR WIRELINE NETWORK; HARDWARE AND FIRMWARE FOR USE IN TRANSMITTING DATA AND/OR VOICE OVER A WIRELESS OR WIRELINE NETWORK; ELECTRONIC DEVICES AND SOFTWARE FOR USE IN TRANSMITTING DATA AND/OR VOICE OVER A WIRELESS OR WIRELINE NETWORK; WIRELESS DATA MODEMS, PORTABLE NETWORK ROUTERS, HAND-HELD WIRELESS MODEMS AND NETWORK ROUTERS, PC WIRELESS CARDS, AND MOBILE COMPUTING AND OPERATING PLATFORMS CONSISTING OF WIRELESS GATEWAYS USED FOR LINKING TERMINALS VIA A COMPUTER NETWORK, RADIO OR FIXED LINE NETWORKS; WIRELESS EMBEDDED MODEM MODULES; COMPUTER SOFTWARE FOR USE IN WIRELESS MODEMS, PORTABLE ROUTERS, AND WIRELESS GATEWAYS FOR LINKING TERMINALS VIA COMPUTER NETWORK, RADIO OR FIXED LINE NETWORKS; WIRELESS COMMUNICATION DEVICES FOR PROVIDING VOICE, DATA, OR IMAGE TRANSMISSION IN WIRELESS COMMUNICATION SERVICES TO ONE OR MORE DEVICES; PORTABLE COMPUTER NETWORK ROUTERS, HAND-HELD WIRELESS COMPUTER NETWORK ROUTERS (U.S. CLS. 21, 23, 26, 36 AND 38).

ODESSA BIBBINS, EXAMINING ATTORNEY

**CLASS 9—(Continued).**

SN 85-016,232. LIGHTSQUARED LP, RESTON, VA. FILED 4-16-2010.

**OPPORTUNITY, MULTIPLIED**

THE MARK CONSISTS OF STANDARD CHARACTERS WITHOUT CLAIM TO ANY PARTICULAR FONT, STYLE, SIZE, OR COLOR.

FOR TELECOMMUNICATIONS EQUIPMENT, NAMELY, CELLULAR TELEPHONES; BROADBAND WIRELESS COMMUNICATIONS EQUIPMENT, NAMELY, TELECOMMUNICATIONS BASE STATION EQUIPMENT FOR CELLULAR AND FIXED NETWORKING AND COMMUNICATIONS APPLICATIONS; NETWORK MANAGEMENT SOFTWARE FOR VOICE AND DATA NETWORKS; GPS NAVIGATION DEVICES AND COMPONENTS USED THEREWITH; NAVIGATION AND POSITIONING EQUIPMENT, NAMELY, SATELLITE AERIALS, DISHES AND RADIOS; COMPUTER SOFTWARE FOR USE IN TRANSMITTING DATA AND/OR VOICE OVER A WIRELESS OR WIRELINE NETWORK; HARDWARE AND FIRMWARE FOR USE IN TRANSMITTING DATA AND/OR VOICE OVER A WIRELESS OR WIRELINE NETWORK; ELECTRONIC DEVICES AND SOFTWARE FOR USE IN TRANSMITTING DATA AND/OR VOICE OVER A WIRELESS OR WIRELINE NETWORK; WIRELESS DATA MODEMS, PORTABLE NETWORK ROUTERS, HAND-HELD WIRELESS MODEMS AND NETWORK ROUTERS, PC WIRELESS CARDS, AND MOBILE COMPUTING AND OPERATING PLATFORMS CONSISTING OF WIRELESS GATEWAYS USED FOR LINKING TERMINALS VIA A COMPUTER NETWORK, RADIO OR FIXED LINE NETWORKS; WIRELESS EMBEDDED MODEM MODULES; COMPUTER SOFTWARE FOR USE IN WIRELESS MODEMS, PORTABLE ROUTERS, AND WIRELESS GATEWAYS FOR LINKING TERMINALS VIA COMPUTER NETWORK, RADIO OR FIXED LINE NETWORKS; WIRELESS COMMUNICATION DEVICES FOR PROVIDING VOICE, DATA, OR IMAGE TRANSMISSION IN WIRELESS COMMUNICATION SERVICES TO ONE OR MORE DEVICES; PORTABLE COMPUTER NETWORK ROUTERS, HAND-HELD WIRELESS COMPUTER NETWORK ROUTERS (U.S. CLS. 21, 23, 26, 36 AND 38).

ODESSA BIBBINS, EXAMINING ATTORNEY

SN 85-016,415. LEE, WAYMAN, MINEOLA, NY. FILED 4-17-2010.

**WAYJ**

THE MARK CONSISTS OF STANDARD CHARACTERS WITHOUT CLAIM TO ANY PARTICULAR FONT, STYLE, SIZE, OR COLOR.

FOR ENVIRONMENT CONTROL APPARATUS, NAMELY, INSTRUMENT PRODUCTS IN THE NATURE OF AUTOMATIC SAFETY VALVES AND NOZZLES, ELECTRIC CURRENT SWITCHES FOR USE WITH ELECTRIC, PROPANE AND WELDING TORCHES TO ELIMINATE ACCIDENTS (U.S. CLS. 21, 23, 26, 36 AND 38).

ERNEST SHOSHO, EXAMINING ATTORNEY

**CLASS 9—(Continued).**

SN 85-019,068. HACKTICS LTD., HERZLIYA, ISRAEL, FILED 4-21-2010.

**Seeker**

THE MARK CONSISTS OF STANDARD CHARACTERS WITHOUT CLAIM TO ANY PARTICULAR FONT, STYLE, SIZE, OR COLOR.

FOR COMPUTER SOFTWARE FOR AUTOMATIC DETECTION OF SECURITY VULNERABILITIES IN COMPUTER SOFTWARE (U.S. CLS. 21, 23, 26, 36 AND 38).

FIRST USE 6-1-2007; IN COMMERCE 1-15-2010.  
ALICIA COLLINS, EXAMINING ATTORNEY

SN 85-019,425. NAV-TV CORPORATION, BOCA RATON, FL. FILED 4-21-2010.

**iTRBO**

THE MARK CONSISTS OF STANDARD CHARACTERS WITHOUT CLAIM TO ANY PARTICULAR FONT, STYLE, SIZE, OR COLOR.

FOR 2-WAY RADIO SYSTEM COMPONENTS, COMPRISED OF COMPUTER OPERATING SOFTWARE AND COMPUTER HARDWARE, RADIOS, REPEATERS AND OTHER HARDWARE, NAMELY, MICROPHONES AND HEADSETS, ALL FOR USE IN CONNECTION WITH 2-WAY COMMUNICATIONS SYSTEMS (U.S. CLS. 21, 23, 26, 36 AND 38).

KATHY DE JONGE, EXAMINING ATTORNEY

SN 85-019,428. NAV-TV CORPORATION, BOCA RATON, FL. FILED 4-21-2010.

**eTRBO**

THE MARK CONSISTS OF STANDARD CHARACTERS WITHOUT CLAIM TO ANY PARTICULAR FONT, STYLE, SIZE, OR COLOR.

FOR 2-WAY RADIO SYSTEM COMPONENTS, COMPRISED OF COMPUTER OPERATING SOFTWARE AND COMPUTER HARDWARE, RADIOS, REPEATERS AND OTHER HARDWARE, NAMELY, MICROPHONES AND HEADSETS, ALL FOR USE IN CONNECTION WITH 2-WAY COMMUNICATIONS SYSTEMS (U.S. CLS. 21, 23, 26, 36 AND 38).

KATHY DE JONGE, EXAMINING ATTORNEY

**CLASS 9—(Continued).**

SN 85-020,361. DELCAM PLC., BIRMINGHAM, UNITED KINGDOM, FILED 4-22-2010.

**CLASS 9—(Continued).**

SN 85-026,024. CASEABLE, LLC, SEABROOK, TX. FILED 4-29-2010.

# ORTHOMILL

THE MARK CONSISTS OF STANDARD CHARACTERS WITHOUT CLAIM TO ANY PARTICULAR FONT, STYLE, SIZE, OR COLOR.

PRIORITY CLAIMED UNDER SEC. 44(D) ON UNITED KINGDOM APPLICATION NO. 9041286, FILED 4-20-2010, REG. NO. 009041286, DATED 11-25-2010, EXPIRES 4-20-2020.

FOR SCANNERS, COMPUTER SOFTWARE AND COMPUTER PROGRAMS FOR THE DESIGN AND MANUFACTURE OF ORTHOTICS AND ORTHOPAEDIC FOOTWEAR; SCANNERS, COMPUTER SOFTWARE AND COMPUTER PROGRAMS FOR WOUND AND INJURY MANAGEMENT (U.S. CLS. 21, 23, 26, 36 AND 38).

WILLIAM VERHOSEK, EXAMINING ATTORNEY



SN 85-020,364. DELCAM PLC., BIRMINGHAM, UNITED KINGDOM, FILED 4-22-2010.

# ORTHOMODEL

THE MARK CONSISTS OF STANDARD CHARACTERS WITHOUT CLAIM TO ANY PARTICULAR FONT, STYLE, SIZE, OR COLOR.

PRIORITY CLAIMED UNDER SEC. 44(D) ON UNITED KINGDOM APPLICATION NO. 9041195, FILED 4-20-2010, REG. NO. 009041195, DATED 11-25-2010, EXPIRES 4-20-2020.

FOR SCANNERS, COMPUTER SOFTWARE AND COMPUTER PROGRAMS FOR THE DESIGN AND MANUFACTURE OF ORTHOTICS AND ORTHOPAEDIC FOOTWEAR; SCANNERS, COMPUTER SOFTWARE AND COMPUTER PROGRAMS FOR WOUND AND INJURY MANAGEMENT (U.S. CLS. 21, 23, 26, 36 AND 38).

WILLIAM VERHOSEK, EXAMINING ATTORNEY

FOR BAGS AND CASES SPECIALLY ADAPTED FOR HOLDING OR CARRYING PORTABLE TELEPHONES AND TELEPHONE EQUIPMENT AND ACCESSORIES; BAGS FOR CAMERAS AND PHOTOGRAPHIC EQUIPMENT; CAMERA CASES; CARRYING CASES FOR CELL PHONES; CARRYING CASES FOR MOBILE COMPUTERS; CARRYING CASES FOR RADIO PAGERS; CARRYING CASES SPECIALLY ADAPTED FOR POCKET CALCULATORS AND CELLPHONES; CASES FOR ELECTRONIC DIARIES; CASES FOR MOBILE PHONES; CASES FOR PHOTOGRAPHIC APPARATUS; CASES FOR SPECTACLES AND SUNGLASSES; CASES FOR TELEPHONES; CD CASES; COMPUTER BAGS; COMPUTER CARRYING CASES; ELECTRONIC BOOK READER; LAPTOP CARRYING CASES; MESSENGER BAGS ESPECIALLY ADAPTED FOR HOLDING ELECTRONIC BOOK READERS; MESSENGER BAGS ESPECIALLY ADAPTED FOR HOLDING LAPTOPS; NEOPRENE LAPTOP COVERS; NOTEBOOK AND LAPTOP COMPUTERS; NOTEBOOK COMPUTER CARRYING CASES; PORTABLE PHOTOGRAPHY EQUIPMENT, NAMELY, REFLECTORS, TRIPODS, LIGHT STANDS AND SUPPORTS AND BAGS SPECIALLY ADAPTED FOR THESE GOODS; PROTECTIVE CARRYING CASES FOR PORTABLE MUSIC PLAYERS, NAMELY, MP3 PLAYERS; PROTECTIVE COVERS AND CASES FOR CELL PHONES, LAPTOPS AND PORTABLE MEDIA PLAYERS; PROTECTIVE SLEEVES FOR LAPTOP COMPUTERS (U.S. CLS. 21, 23, 26, 36 AND 38).

MARK SPARACINO, EXAMINING ATTORNEY

**CLASS 9—(Continued).**

SN 85-026,432. GO-TECH ENERGY CO., LTD., SIJHIH, TAIPEI COUNTY, TAIWAN, FILED 4-29-2010.

# EXN

THE MARK CONSISTS OF STANDARD CHARACTERS WITHOUT CLAIM TO ANY PARTICULAR FONT, STYLE, SIZE, OR COLOR.

OWNER OF TAIWAN REG. NO. 01436767, DATED 11-1-2010, EXPIRES 10-31-2020.

FOR ACCUMULATOR BOXES; ACCUMULATORS AND BATTERIES; BATTERIES FOR LIGHTING; BATTERY CHARGERS; BATTERY JARS; ELECTRIC CONTROL PANELS; AUTOMATIC DISTRIBUTION MACHINES; ELECTRIC ACCUMULATORS AND BATTERIES FOR VEHICLES; ELECTRO-DYNAMIC APPARATUS FOR THE REMOTE CONTROL OF SIGNALS COMPRISED OF RFID DETECTORS; SMART CARDS IN THE NATURE OF INTEGRATED CIRCUIT CARDS; BATTERY ENERGY EXCHANGE NETWORK SYSTEM COMPRISING BATTERY PACK CHARGING AND SWAP STATIONS, AN ELECTRONIC APPARATUS FOR USE IN THE MEASUREMENT OF BATTERY STATUS, AN ELECTRONIC CHARGER APPARATUS FOR USE IN THE CHARGE ENERGY TO BATTERIES, A REMOTE COMPUTER MANAGEMENT PROGRAM AND DATABASE THAT IS USED TO RECORD AND MONITOR BATTERY CHARGING AND SWAP STATIONS, INTEGRATED SMART CARD AND RFID SYSTEMS FOR THE INFORMATION MANAGEMENT (U.S. CLS. 21, 23, 26, 36 AND 38).

DAWN FELDMAN, EXAMINING ATTORNEY

SN 85-027,137. SECUTOR SYSTEMS, LLC, CHESAPEAKE, VA. FILED 4-30-2010.

# SECUTOR

THE MARK CONSISTS OF STANDARD CHARACTERS WITHOUT CLAIM TO ANY PARTICULAR FONT, STYLE, SIZE, OR COLOR.

FOR COMPUTER HARDWARE AND COMPUTER PERIPHERAL DEVICES (U.S. CLS. 21, 23, 26, 36 AND 38).

FIRST USE 3-30-2007; IN COMMERCE 3-30-2007.  
HANNO RITTNER, EXAMINING ATTORNEY

**CLASS 9—(Continued).**

SN 85-032,021. CLEARONE COMMUNICATIONS, SALT LAKE CITY, UT. FILED 5-6-2010.

# VIEW

THE MARK CONSISTS OF STANDARD CHARACTERS WITHOUT CLAIM TO ANY PARTICULAR FONT, STYLE, SIZE, OR COLOR.

FOR WIRED AND WIRELESS ELECTRICAL AND ELECTRONIC APPARATUS, NAMELY, AUDIO/VIDEO DISTRIBUTION SYSTEMS CONSISTING OF AMPLIFIERS, PRE-AMPLIFIERS, AUDIO RECEIVERS, ENCODERS AND DECODERS, IN-WALL KEYPADS, TABLETOP AND PORTABLE REMOTE CONTROLS (U.S. CLS. 21, 23, 26, 36 AND 38).

DAWN HAN, EXAMINING ATTORNEY

SN 85-033,737. JUDOKA MOBILE LLC, INDIANAPOLIS, IN. FILED 5-9-2010.

# AyahPod

THE MARK CONSISTS OF STANDARD CHARACTERS WITHOUT CLAIM TO ANY PARTICULAR FONT, STYLE, SIZE, OR COLOR.

FOR COMPUTER HARDWARE AND COMPUTER PERIPHERAL DEVICES (U.S. CLS. 21, 23, 26, 36 AND 38).

INGA ERVIN, EXAMINING ATTORNEY

SN 85-034,362. NAV-TV CORPORATION, BOCA RATON, FL. FILED 5-10-2010.

# AIRSHARK

THE MARK CONSISTS OF STANDARD CHARACTERS WITHOUT CLAIM TO ANY PARTICULAR FONT, STYLE, SIZE, OR COLOR.

FOR 2-WAY RADIO SYSTEM COMPONENTS, COMPRISED OF COMPUTER OPERATING SOFTWARE AND COMPUTER HARDWARE, RADIOS, REPEATERS AND OTHER HARDWARE, NAMELY, MICROPHONES AND HEADSETS, ALL FOR USE IN CONNECTION WITH 2-WAY COMMUNICATIONS SYSTEMS (U.S. CLS. 21, 23, 26, 36 AND 38).

KATHY DE JONGE, EXAMINING ATTORNEY



**CLASS 9—(Continued).**

SN 85-034,939. SYNAPTRIS INC., DBA SYNAPTRIS INC., SAN JOSE, CA. FILED 5-11-2010.

**FewClix**  
email made easy

NO CLAIM IS MADE TO THE EXCLUSIVE RIGHT TO USE "EMAIL", APART FROM THE MARK AS SHOWN.

THE COLOR(S) BLACK AND ORANGE IS/ARE CLAIMED AS A FEATURE OF THE MARK.

THE MARK CONSISTS OF THE WORD "FEW" IN BLACK AND "CLIX" IN ORANGE COLOR WITH "EMAIL MADE EASY" WRITTEN IN BLACK UNDERNEATH.

FOR COMPUTER SOFTWARE PLATFORMS FOR EMAIL PRODUCTIVITY (U.S. CLS. 21, 23, 26, 36 AND 38).

FIRST USE 1-14-2010; IN COMMERCE 1-14-2010.  
SHAUNIA CARLYLE, EXAMINING ATTORNEY

**CLASS 9—(Continued).**

SN 85-037,381. ABB AB, VÄSTERÅS, SWEDEN, FILED 5-13-2010.

**THE BRAIN OF YOUR CRANE**

THE MARK CONSISTS OF STANDARD CHARACTERS WITHOUT CLAIM TO ANY PARTICULAR FONT, STYLE, SIZE, OR COLOR.

PRIORITY CLAIMED UNDER SEC. 44(D) ON ERP N CMNTY TM OFC APPLICATION NO. 008779795, FILED 12-23-2009, REG. NO. 008779795, DATED 6-15-2010, EXPIRES 12-23-2019.

NO CLAIM IS MADE TO THE EXCLUSIVE RIGHT TO USE "CRANE", APART FROM THE MARK AS SHOWN.

FOR ELECTRIC AND ELECTRONIC CONTROL SYSTEMS FOR OPERATING CRANES (U.S. CLS. 21, 23, 26, 36 AND 38).

NAPOLEON SHARMA, EXAMINING ATTORNEY

SN 85-037,608. ABB AB, VÄSTERÅS, SWEDEN, FILED 5-13-2010.

**MOCON ROBUST**

THE MARK CONSISTS OF STANDARD CHARACTERS WITHOUT CLAIM TO ANY PARTICULAR FONT, STYLE, SIZE, OR COLOR.

PRIORITY CLAIMED UNDER SEC. 44(D) ON ERP N CMNTY TM OFC APPLICATION NO. 008779721, FILED 12-23-2009, REG. NO. 008779721, DATED 6-15-2010, EXPIRES 12-23-2019.

FOR ELECTRIC AND ELECTRONIC CONTROL SYSTEMS FOR OPERATING CRANES (U.S. CLS. 21, 23, 26, 36 AND 38).

NAPOLEON SHARMA, EXAMINING ATTORNEY

SN 85-037,643. ABB AB, VÄSTERÅS, SWEDEN, FILED 5-13-2010.

**MOCON**

THE MARK CONSISTS OF STANDARD CHARACTERS WITHOUT CLAIM TO ANY PARTICULAR FONT, STYLE, SIZE, OR COLOR.

PRIORITY CLAIMED UNDER SEC. 44(D) ON ERP N CMNTY TM OFC APPLICATION NO. 008779654, FILED 12-23-2009, REG. NO. 008779654, DATED 8-24-2010, EXPIRES 12-23-2019.

FOR ELECTRIC AND ELECTRONIC CONTROL SYSTEMS FOR OPERATING CRANES (U.S. CLS. 21, 23, 26, 36 AND 38).

NAPOLEON SHARMA, EXAMINING ATTORNEY

SN 85-037,298. BABY WALKING PRODUCTIONS, LLC, DBA BABY GOES PRO, TAMPA, FL. FILED 5-13-2010.



THE MARK CONSISTS OF AN ANIMATED PRIMATE WEARING ATHLETIC SHOES AND A CAP, THE WORDING "BABY GOES PRO" NEXT TO THE PRIMATE WHERE THE "O" IN "GOES" IS A BASKETBALL AND THE "O" IN "PRO" IS A BASEBALL, AND THE WORDING "INSPIRING A GENERATION TO MOVE" STARTING AT THE PRIMATE'S HAND AND EXTENDING TOWARD THE BOTTOM OF THE MARK AND FOLLOWED BY A SHADED CIRCLE.

FOR DVDS FEATURING SPORTS TRAINING VIDEOS FOR CHILDREN (U.S. CLS. 21, 23, 26, 36 AND 38).

KATHLEEN LORENZO, EXAMINING ATTORNEY

**CLASS 9—(Continued).**

SN 85-039,721. ULTRACONCURRENT, INC., APTOS, CA.  
FILED 5-16-2010.

# iEntertain

THE MARK CONSISTS OF STANDARD CHARACTERS WITHOUT CLAIM TO ANY PARTICULAR FONT, STYLE, SIZE, OR COLOR.

FOR COMPUTER OPERATING PROGRAMS THAT AID IN MEDIATION AND ORGANIZATION OF SMART PHONE APPLICATIONS USED FOR ENTERTAINMENT PURPOSES (U.S. CLS. 21, 23, 26, 36 AND 38).

CHRISTINE COOPER, EXAMINING ATTORNEY

SN 85-039,883. ROUTEINC., TORONTO, CANADA, FILED  
5-17-2010.

# MOBIKEY

THE MARK CONSISTS OF STANDARD CHARACTERS WITHOUT CLAIM TO ANY PARTICULAR FONT, STYLE, SIZE, OR COLOR.

PRIORITY CLAIMED UNDER SEC. 44(D) ON CANADA APPLICATION NO. 1461713, FILED 12-4-2009, REG. NO. TMA779885, DATED 10-15-2010, EXPIRES 10-15-2025.

OWNER OF U.S. REG. NO. 3,531,048.

FOR COMPUTER HARDWARE DEVICE, NAMELY, A USB INTERFACE, MEMORY CARD AND DRIVE, NFC DEVICE, SMART CARD, RFID TAG, FOB, DONGLE AND TOKEN TO PROVIDE SECURE ACCESS, DATA PROTECTION, AUTHORIZATION, TRANSACTION SIGNING, SECURE VOICE, VIDEO OR DATA COMMUNICATION AND IDENTITY MANAGEMENT TO DIGITAL RESOURCES, APPLICATIONS, DATA, MULTIMEDIA CONTENT, NAMELY, AUDIO, VIDEO, CONDITIONAL ACCESS BROADCASTS, MOTION PICTURES, INTRANETS AND THE INTERNET (U.S. CLS. 21, 23, 26, 36 AND 38).

ALEXANDER L. POWERS, EXAMINING ATTORNEY

SN 85-044,290. FRONTIER FASHION, INC., CITY OF INDUSTRY, CA. FILED 5-20-2010.



THE MARK CONSISTS OF THE STYLIZED DESIGN OF A LARGE, WILD CAT.

FOR SUNGLASSES (U.S. CLS. 21, 23, 26, 36 AND 38).  
KAREN BRACEY, EXAMINING ATTORNEY

**CLASS 9—(Continued).**

SN 85-046,296. TRINITY, INC., SAITAMA-KEN, JAPAN,  
FILED 5-24-2010.

# EVENNO

THE MARK CONSISTS OF STANDARD CHARACTERS WITHOUT CLAIM TO ANY PARTICULAR FONT, STYLE, SIZE, OR COLOR.

PRIORITY CLAIMED UNDER SEC. 44(D) ON JAPAN APPLICATION NO. 2009098012, FILED 12-25-2009, REG. NO. 5343988, DATED 8-6-2010, EXPIRES 8-6-2020.

THE WORDING "EVENNO" HAS NO MEANING IN A FOREIGN LANGUAGE.

FOR COMPUTER SOFTWARE FEATURING MUSICAL SOUND RECORDINGS AND MUSICAL VIDEO RECORDINGS; DOWNLOADABLE MUSICAL SOUND RECORDINGS; ELECTRICAL CABLES FOR MUSICAL INSTRUMENTS; ELECTRICAL PICKUPS FOR USE WITH MUSICAL INSTRUMENTS; JUKE BOXES; MUSICAL INSTRUMENT ADAPTERS; MUSICAL INSTRUMENT AMPLIFIERS; MUSICAL INSTRUMENT CONNECTORS; MUSICAL SOUND RECORDINGS; MUSICAL VIDEO RECORDINGS; PORTABLE MEDIA PLAYERS; BATTERY CHARGERS; ACCESSORIES FOR DIGITAL AUDIO PLAYERS, NAMELY, DIGITAL AUDIO PLAYER CASES, CHARGERS, PROTECTIVE SLEEVES, AND ADAPTERS; ACCESSORIES FOR PORTABLE PHONES, NAMELY, PORTABLE PHONE CASES, CHARGERS, PROTECTIVE SLEEVES, AND ADAPTERS; HOME THEATER PRODUCTS, NAMELY, ELECTRONIC SWITCHERS FOR AUDIO AND VISUAL SIGNALS; BATTERIES; AUDIO CABLES; RADIO TRANSMITTERS; LOUD SPEAKERS; EAR PHONES; HEAD PHONES; STANDS FOR PHOTOGRAPHIC APPARATUS (U.S. CLS. 21, 23, 26, 36 AND 38).

FIRST USE 1-7-2010; IN COMMERCE 1-7-2010.

STEVEN PEREZ, EXAMINING ATTORNEY

SN 85-047,515. PASON SYSTEMS CORP., CALGARY, ALBERTA, CANADA, FILED 5-25-2010.

# RIGBRAIN

THE MARK CONSISTS OF STANDARD CHARACTERS WITHOUT CLAIM TO ANY PARTICULAR FONT, STYLE, SIZE, OR COLOR.

FOR COMPUTER HARDWARE AND COMPUTER SOFTWARE FOR ACCESSING, DISPLAYING, REPORTING AND RECORDING DATA AND INFORMATION ABOUT DRILLING PARAMETERS AND OPERATIONS, LOCALLY AND REMOTELY FOR AUTOMATING AND GENERATING REPORTS, AND FOR COMMUNICATING WITH CONTROLLERS, DRILLING EQUIPMENT, AND COMPUTER NETWORKS (U.S. CLS. 21, 23, 26, 36 AND 38).

FIRST USE 5-1-2008; IN COMMERCE 5-1-2008.

JEAN IM, EXAMINING ATTORNEY

**CLASS 9—(Continued).**

SN 85-049,062. SCHLUMBERGER CANADA LIMITED, CALGARY, ALBERTA, CANADA, FILED 5-27-2010.

# AQUACHEM

THE MARK CONSISTS OF STANDARD CHARACTERS WITHOUT CLAIM TO ANY PARTICULAR FONT, STYLE, SIZE, OR COLOR.

FOR SOFTWARE IN THE FIELD OF MANAGEMENT, ANALYSIS AND REPORTING WATER QUALITY DATA (U.S. CLS. 21, 23, 26, 36 AND 38).

FIRST USE 0-0-1999; IN COMMERCE 0-0-1999.  
JENNIFER MARTIN, EXAMINING ATTORNEY

---

SN 85-049,686. BUSINESS RESEARCHERS, INC., SAN FRANCISCO, CA. FILED 5-27-2010.

# UPSTREAM

THE MARK CONSISTS OF STANDARD CHARACTERS WITHOUT CLAIM TO ANY PARTICULAR FONT, STYLE, SIZE, OR COLOR.

FOR COMPUTER SOFTWARE FOR DATA COLLECTION AND ANALYSIS, FINANCIAL PLANNING FOR MARKETING CAMPAIGNS AND MARKETING WORKFLOW MANAGEMENT (U.S. CLS. 21, 23, 26, 36 AND 38).  
CARYN GLASSER, EXAMINING ATTORNEY

---

SN 85-054,043. CRESTRON ELECTRONICS, INC., ROCKLEIGH, NJ. FILED 6-3-2010.

# EXCITE

THE MARK CONSISTS OF STANDARD CHARACTERS WITHOUT CLAIM TO ANY PARTICULAR FONT, STYLE, SIZE, OR COLOR.

FOR AUDIO ELECTRONIC COMPONENTS, NAMELY, SURROUND SOUND SYSTEMS; AUDIO SPEAKER ENCLOSURES, AUDIO SPEAKERS, BASS SPEAKERS, LOUD SPEAKERS, LOUD SPEAKER SYSTEMS, AUDIO SPEAKERS THAT ARE DESIGNED TO BE MOUNTED INSIDE AN OPENING IN A WALL; ARCHITECTURAL AUDIO SPEAKERS, NAMELY, SPEAKERS THAT ARE CAPABLE OF BEING MOUNTED FLUSH WITH A WALL, CEILING, OR OTHER SURFACE OR ENCLOSURE SO THE SPEAKERS APPEAR TO BE PART OF THE BUILDING (U.S. CLS. 21, 23, 26, 36 AND 38).  
BARBARA A. GOLD, EXAMINING ATTORNEY

**CLASS 9—(Continued).**

SN 85-056,070. DIAMOND COMPUTING COMPANY, TUCKER, GA. FILED 6-7-2010.

# LabGEM

THE MARK CONSISTS OF STANDARD CHARACTERS WITHOUT CLAIM TO ANY PARTICULAR FONT, STYLE, SIZE, OR COLOR.

FOR COMPUTER SOFTWARE FOR OPERATING AND MANAGING HOSPITAL AND MEDICAL LABORATORIES (U.S. CLS. 21, 23, 26, 36 AND 38).

FIRST USE 3-1-1984; IN COMMERCE 3-1-1984.  
RUSS HERMAN, EXAMINING ATTORNEY

---

SN 85-057,464. BATTERY HANDLING SYSTEMS, INC., ST. LOUIS, MO. FILED 6-8-2010.



The logo for Fleet Tracker features the words "Fleet Tracker" in a bold, italicized, sans-serif font. To the left of the word "Fleet" is a stylized graphic of a battery with three horizontal lines extending from its top, suggesting power or motion.

NO CLAIM IS MADE TO THE EXCLUSIVE RIGHT TO USE "FLEET TRACKER", APART FROM THE MARK AS SHOWN.

THE MARK CONSISTS OF "FLEET TRACKER" TO THE RIGHT OF AN IMAGE OF A BATTERY WITH MOVEMENT MARKS; WITH THE LOWER PORTION OF THE "L" IN "FLEET" BEING A LINE DEPICTING SPEED AND EXTENDING ACROSS THE BOTTOM PORTION OF THE MARK.

FOR BATTERY MANAGEMENT SYSTEMS, NAMELY, COMPUTERIZED SYSTEMS FOR MANAGING THE STORAGE, MAINTENANCE, WASHING, CHARGE, USE AND STATUS OF 3,000 LB INDUSTRIAL FORK LIFT BATTERIES AND BATTERY RELATED EQUIPMENT COMPRISING COMPUTER SOFTWARE AND VIDEO DISPLAY SCREENS (U.S. CLS. 21, 23, 26, 36 AND 38).  
CHRISIE B. KING, EXAMINING ATTORNEY

**CLASS 9—(Continued).**

SN 85-059,165. CERADYNE, INC., COSTA MESA, CA. FILED 6-10-2010.



NO CLAIM IS MADE TO THE EXCLUSIVE RIGHT TO USE "POLICE & ARMOR", APART FROM THE MARK AS SHOWN.

THE COLOR(S) BLACK, GRAY, WHITE AND RED IS/ARE CLAIMED AS A FEATURE OF THE MARK.

THE MARK CONSISTS OF THE WORD "MAX" IN RED LETTERING, WITH THE WORD "PRO" IN BLACK LETTERING DIRECTLY UNDERNEATH, FOLLOWED BY A RED AND BLACK CIRCULAR DESIGN WITH THE LETTERS "M" IN WHITE, "P" IN GRAY AND "P" IN WHITE PLACED WITHIN THE CIRCULAR DESIGN; THE WORD "POLICE" IN BLACK LETTERING PLACED AFTER THE CIRCULAR DESIGN AND THE SYMBOL "&" IN RED PLACED UNDERNEATH THE LETTER "P" IN THE WORD "POLICE" FOLLOWED BY THE WORD "ARMOR" IN RED.

FOR PROTECTIVE ARMOR FOR PERSONAL, VEHICLE AND STRUCTURAL APPLICATIONS, NAMELY, BODY ARMOR AND PROTECTIVE ARMOR PANELS FOR PROTECTING AGAINST BALLISTIC PROJECTILES AND EXPLOSIVE FRAGMENTS INSTALLED IN OR ATTACHED TO VEHICLES, BUILDINGS OR OTHER STRUCTURES (U.S. CLS. 21, 23, 26, 36 AND 38).

FIRST USE 3-0-2008; IN COMMERCE 3-0-2008.

JANICE L. MCMORROW, EXAMINING ATTORNEY

SN 85-060,085. INTOUCH TECHNOLOGIES, INC., DBA INTOUCH HEALTH, GOLETA, CA. FILED 6-10-2010.

## RP-Vantage

THE MARK CONSISTS OF STANDARD CHARACTERS WITHOUT CLAIM TO ANY PARTICULAR FONT, STYLE, SIZE, OR COLOR.

OWNER OF U.S. REG. NOS. 3,105,069, 3,761,802 AND OTHERS.

FOR REMOTELY CONTROLLED SYSTEM FOR USE IN WIRELESS TELECOMMUNICATIONS COMPRISED OF COMPUTER HARDWARE, COMPUTER SOFTWARE, MONITORS, CAMERAS, MOTORS AND A LASER POINTER THAT IS MANIPULATED BY A REMOTE OPERATOR TO TRANSMIT 2-WAY AUDIO AND VIDEO COMMUNICATIONS AND OTHER ELECTRONIC DATA (U.S. CLS. 21, 23, 26, 36 AND 38).

AISHA CLARKE, EXAMINING ATTORNEY

**CLASS 9—(Continued).**

SN 85-063,940. PURE ACOUSTICS, INC., BROOKLYN, NY. FILED 6-16-2010.

## hipbox

THE COLOR(S) BLACK AND GRAY IS/ARE CLAIMED AS A FEATURE OF THE MARK.

THE MARK CONSISTS OF THREE LETTERS IN GRAY "HIP" AND THREE LETTERS IN BLACK "BOX".

FOR AUDIO SPEAKERS (U.S. CLS. 21, 23, 26, 36 AND 38).

MARK SPARACINO, EXAMINING ATTORNEY

SN 85-065,206. A&E TELEVISION NETWORKS, LLC, NEW YORK, NY. FILED 6-17-2010.

## CRIME 360

THE MARK CONSISTS OF STANDARD CHARACTERS WITHOUT CLAIM TO ANY PARTICULAR FONT, STYLE, SIZE, OR COLOR.

OWNER OF U.S. REG. NO. 3,459,001.

NO CLAIM IS MADE TO THE EXCLUSIVE RIGHT TO USE "CRIME", APART FROM THE MARK AS SHOWN.

FOR MULTIMEDIA, NAMELY, PRERECORDED DIGITAL VIDEO DISCS AND DVDS ALL FEATURING CRIMINAL INVESTIGATIONS; DIGITAL MEDIA, NAMELY, DOWNLOADABLE AUDIO AND VIDEO FILES FEATURING CRIMINAL INVESTIGATIONS; DOWNLOADABLE WEBCASTS IN THE FIELD OF CRIMINAL INVESTIGATIONS (U.S. CLS. 21, 23, 26, 36 AND 38).

FIRST USE 3-5-2008; IN COMMERCE 3-5-2008.

BERYL GARDNER, EXAMINING ATTORNEY

SN 85-067,996. PARAMOUNT EQUITY, DBA PARAMOUNT ENERGY SOLUTIONS, ROSEVILLE, CA. FILED 6-21-2010.

## Paramount Energy Solutions

THE MARK CONSISTS OF STANDARD CHARACTERS WITHOUT CLAIM TO ANY PARTICULAR FONT, STYLE, SIZE, OR COLOR.

NO CLAIM IS MADE TO THE EXCLUSIVE RIGHT TO USE "ENERGY SOLUTIONS", APART FROM THE MARK AS SHOWN.

FOR PHOTOVOLTAIC SOLAR MODULES FOR PRODUCTION OF ELECTRICITY; SOLAR PANELS FOR PRODUCTION OF ELECTRICITY (U.S. CLS. 21, 23, 26, 36 AND 38).

FIRST USE 8-1-2009; IN COMMERCE 8-1-2009.

JILL PRATER, EXAMINING ATTORNEY

**CLASS 9—(Continued).**

SN 85-078,230. B.O.S. COMPANY, LLC, GOLDEN VALLEY, MN. FILED 7-6-2010.

# Turtle

THE MARK CONSISTS OF STANDARD CHARACTERS WITHOUT CLAIM TO ANY PARTICULAR FONT, STYLE, SIZE, OR COLOR.

FOR OFF-SITE TRANSPORTATION AND STORAGE CASE MADE OF PLASTIC MATERIAL, FOR COMPUTER CARTRIDGES (U.S. CLS. 21, 23, 26, 36 AND 38).

FIRST USE 12-1-1987; IN COMMERCE 2-1-1988.  
APRIL ROACH, EXAMINING ATTORNEY

---

SN 85-078,803. HANDI QUILTER, INC., NORTH SALT LAKE, UT. FILED 7-6-2010.



OWNER OF U.S. REG. NOS. 2,920,821, 3,559,066 AND OTHERS.

NO CLAIM IS MADE TO THE EXCLUSIVE RIGHT TO USE "HANDY QUILTER", APART FROM THE MARK AS SHOWN.

THE MARK CONSISTS OF A STYLIZED IMAGE OF A NEEDLE AND THREAD TO THE LEFT OF THE WORDS "HANDI QUILTER", WITH THE THREAD CONTINUING BELOW THE WORDS AS A DASHED LINE.

FOR PRERECORDED VIDEOS AND DVDS FEATURING QUILTING (U.S. CLS. 21, 23, 26, 36 AND 38).

FIRST USE 9-29-2008; IN COMMERCE 9-29-2008.  
RONALD AIKENS, EXAMINING ATTORNEY

---

SN 85-079,151. C3 SOFTWARES, MINNEAPOLIS, MN. FILED 7-7-2010.

# C3 SoftWorks

THE MARK CONSISTS OF STANDARD CHARACTERS WITHOUT CLAIM TO ANY PARTICULAR FONT, STYLE, SIZE, OR COLOR.

FOR COMPUTER GAME SOFTWARE (U.S. CLS. 21, 23, 26, 36 AND 38).

FIRST USE 8-25-2008; IN COMMERCE 8-25-2008.  
MARK SPARACINO, EXAMINING ATTORNEY

**CLASS 9—(Continued).**

SN 85-082,206. JOHNSON'S INNOVATIONS, LLC, ITHACA, MI. FILED 7-12-2010.

# Peek-A-Boom

THE MARK CONSISTS OF STANDARD CHARACTERS WITHOUT CLAIM TO ANY PARTICULAR FONT, STYLE, SIZE, OR COLOR.

FOR AUTOMATIC LIQUID-FLOW CONTROL MACHINES AND INSTRUMENTS; AUTOMATIC PRESSURE CONTROL MACHINES AND INSTRUMENTS; ELECTRICAL CONTROLLING DEVICES; ELECTRICAL INTEGRATED CONTROL SYSTEMS FOR USE IN THE FIELD OF AGRICULTURAL AND INDUSTRIAL SPRAYING (U.S. CLS. 21, 23, 26, 36 AND 38).

FIRST USE 10-1-2008; IN COMMERCE 10-1-2009.  
DAVID C. REIHNER, EXAMINING ATTORNEY

---

SN 85-083,515. PUBLIC SAFETY CORPORATION, FORMERLY AOT PUBLIC SAFETY CORPORATION, WALDORF, MD. FILED 7-13-2010.

# CRYWOLF

THE MARK CONSISTS OF STANDARD CHARACTERS WITHOUT CLAIM TO ANY PARTICULAR FONT, STYLE, SIZE, OR COLOR.

OWNER OF U.S. REG. NO. 2,711,707.

FOR COMPUTER SOFTWARE FOR THE PURPOSE OF ASSISTING EMERGENCY PERSONNEL IN GOVERNMENT AGENCIES AND PRIVATE INDUSTRY DURING EMERGENCIES, DISASTERS, AND CATASTROPHES, NAMELY, COMPUTER SOFTWARE THAT TRACKS, PROCESSES, DOCUMENTS, AND ACCOUNTS FOR FALSE ALARMS BY ANALYZING, SUMMARIZING, CHARTING, GRAPHING AND COLOR CODING ALARM INCIDENT INFORMATION AND SENDING NOTIFICATION AND BILLING FORMS TO BUSINESSES AND/OR RESIDENCES WHERE THE FALSE ALARM ORIGINATED (U.S. CLS. 21, 23, 26, 36 AND 38).

FIRST USE 10-5-2000; IN COMMERCE 10-5-2000.  
STEVEN JACKSON, EXAMINING ATTORNEY

**CLASS 9—(Continued).**

SN 85-086,626. CHEN, MARCO, SHENZHEN, CHINA, FILED 7-16-2010.

The logo consists of the word "roadi" in a bold, lowercase, sans-serif font. The letters are red. The 'o' and 'a' are connected, and the 'i' has a dot.

THE COLOR(S) RED IS/ARE CLAIMED AS A FEATURE OF THE MARK.

THE MARK CONSISTS OF THE STYLIZED WORDING "ROADI" IN RED.

THE WORDING "ROADI" HAS NO MEANING IN A FOREIGN LANGUAGE.

FOR AUTOMOTIVE MEASURING INSTRUMENTS, NAMELY, WATER TEMPERATURE GAUGES, AIR FUEL/RATIO GAUGES, BOOST GAUGES, VACUUM GAUGES AND EXHAUST GAS TEMPERATURE GAUGES; AUTOMOTIVE TESTING EQUIPMENT, NAMELY, TRANSMISSION TESTING AND BRAKE TESTING EQUIPMENT; SENSORS AND DETECTOR UNITS FOR USE IN CONTROLLING THE ACTUATION AND OPERATION OF AUTOMOTIVE SAFETY APPARATUS AND EQUIPMENT (U.S. CLS. 21, 23, 26, 36 AND 38).

ROBIN MITTLER, EXAMINING ATTORNEY

---

SN 85-086,706. INUNI, INC., MADISON, WI. FILED 7-16-2010.

The logo consists of the word "inUni" in a lowercase, serif font. The letters are black. The 'i' and 'n' are connected, and the 'U' is uppercase.

THE MARK CONSISTS OF STANDARD CHARACTERS WITHOUT CLAIM TO ANY PARTICULAR FONT, STYLE, SIZE, OR COLOR.

FOR MAGNETIC CODED CARDS USED FOR OFFERING DISCOUNTS TO PATRONS OF EXCLUSIVE VENDOR NETWORKS THAT UTILIZE SOCIAL MEDIA AND INFORMATION TECHNOLOGY (IT) PLATFORMS TO BETTER CONNECT MERCHANTS AND CUSTOMERS, AND IMPROVE THE USER EXPERIENCE (U.S. CLS. 21, 23, 26, 36 AND 38).

FIRST USE 1-30-2010; IN COMMERCE 1-30-2010.

BRIAN CALLAGHAN, EXAMINING ATTORNEY

**CLASS 9—(Continued).**

SN 85-087,009. REMINDERBAND, INC., LOGAN, UT. FILED 7-16-2010.

The logo consists of the word "IFROGZ" in a bold, uppercase, serif font. The letters are black.

THE MARK CONSISTS OF STANDARD CHARACTERS WITHOUT CLAIM TO ANY PARTICULAR FONT, STYLE, SIZE, OR COLOR.

OWNER OF U.S. REG. NO. 3,309,320.

FOR EARPHONES AND HEADPHONES; AUDIO SPEAKERS; CHARGERS FOR BATTERIES AND POWER ACCESSORIES FOR PERSONAL ELECTRONIC DEVICES, NAMELY, CELL PHONES, PERSONAL MUSIC PLAYERS, TABLET-STYLE COMPUTERS, HANDHELD COMPUTERS, HANDHELD GAMING DEVICES, LAPTOPS, AND MEDIA PLAYERS; PROTECTIVE CASES FOR ELECTRONIC DEVICES, NAMELY, CELL PHONES, PERSONAL MUSIC PLAYERS, TABLET-STYLE COMPUTERS, HANDHELD COMPUTERS, HANDHELD GAMING DEVICES, LAPTOPS, AND MEDIA PLAYERS, CLEAR PROTECTIVE COVER FILM FOR PERSONAL ELECTRONIC DEVICES; CLEAR PROTECTIVE COVER FILM FOR ELECTRONIC SCREENS ON PERSONAL ELECTRONIC DEVICES; BAGS AND POUCHES SPECIFICALLY ADAPTED FOR HOLDING OR CARRYING ELECTRONIC DEVICES, NAMELY, CELL PHONES, PERSONAL MUSIC PLAYERS, TABLET-STYLE COMPUTERS, HANDHELD COMPUTERS, HANDHELD GAMING DEVICES, LAPTOPS, AND MEDIA PLAYERS; CASES AND CONTAINERS SPECIFICALLY ADAPTED FOR HOLDING, CARRYING, AND PROTECTING ELECTRONIC DEVICES, NAMELY, CELL PHONES, PERSONAL MUSIC PLAYERS, TABLET-STYLE COMPUTERS, HANDHELD COMPUTERS, HANDHELD GAMING DEVICES, LAPTOPS, AND MEDIA PLAYERS; PROTECTIVE CARRYING SLEEVES AND ARMBANDS FOR ELECTRONIC DEVICES, NAMELY, CELL PHONES, PERSONAL MUSIC PLAYERS, TABLET-STYLE COMPUTERS, HANDHELD COMPUTERS, HANDHELD GAMING DEVICES, LAPTOPS, AND MEDIA PLAYERS; MEDIA PLAYERS; ELECTRONIC CABLES; DIGITAL AUDIO COMPONENTS, NAMELY, PERSONAL RADIO AND VIDEO TUNERS AND TRANSMITTERS; ELECTRICAL AND ELECTRONIC CONNECTORS; MOBILE MEDIA DEVICE SOFTWARE AND APPLICATIONS, NAMELY, SOFTWARE APPLICATIONS FOR CREATING AND BUYING PROTECTIVE CASES FOR ELECTRONIC DEVICES, BAGS AND POUCHES SPECIFICALLY ADAPTED FOR HOLDING OR CARRYING ELECTRONIC DEVICES, CASES AND CONTAINERS SPECIFICALLY ADAPTED FOR HOLDING, CARRYING, AND PROTECTING ELECTRONIC DEVICES, AND PROTECTIVE CARRYING SLEEVES AND ARMBANDS FOR ELECTRONIC DEVICES (U.S. CLS. 21, 23, 26, 36 AND 38).

FRANK LATTUCA, EXAMINING ATTORNEY

**CLASS 9—(Continued).**

SN 85-087,850. ZLANTRADER, LLC, CHICAGO, IL. FILED 7-19-2010.

# Zlantrader

THE MARK CONSISTS OF STANDARD CHARACTERS WITHOUT CLAIM TO ANY PARTICULAR FONT, STYLE, SIZE, OR COLOR.

FOR COMPUTER PROGRAMS AND COMPUTER SOFTWARE FOR ELECTRONICALLY TRADING SECURITIES (U.S. CLS. 21, 23, 26, 36 AND 38).

FIRST USE 7-1-2010; IN COMMERCE 7-1-2010.  
KRISTIN DAHLING, EXAMINING ATTORNEY

SN 85-096,325. COCOA BOX DESIGN LLC, SAN FRANCISCO, CA. FILED 7-29-2010.

# PENULTIMATE

THE MARK CONSISTS OF STANDARD CHARACTERS WITHOUT CLAIM TO ANY PARTICULAR FONT, STYLE, SIZE, OR COLOR.

FOR SOFTWARE APPLICATION FOR ELECTRONICALLY CAPTURING AND MANIPULATING NOTES, DRAWINGS AND IMAGES WHICH HAVE BEEN WRITTEN OR DRAWN ONTO THE SCREEN OF A COMPUTERIZED ELECTRONIC DEVICE (U.S. CLS. 21, 23, 26, 36 AND 38).

FIRST USE 4-15-2010; IN COMMERCE 4-15-2010.  
KELLEY WELLS, EXAMINING ATTORNEY

SN 85-096,392. ANYDATA CORPORATION, DBA ANYDATA, IRVINE, CA. FILED 7-29-2010.



THE MARK CONSISTS OF THE STYLIZED WORDING "I PORT" WITH A RAISED PERIOD BETWEEN THE LETTER "I" AND THE WORD "PORT" AND TWO SMALL CIRCLES TO THE RIGHT OF THE LETTER "T" IN "PORT".

FOR CODE DIVISION MULTIPLE ACCESS (CDMA) EXTERNAL MODEMS FOR WIRELESS ACCESS (U.S. CLS. 21, 23, 26, 36 AND 38).

FIRST USE 12-1-2001; IN COMMERCE 1-1-2002.  
BARBARA GAYNOR, EXAMINING ATTORNEY

**CLASS 9—(Continued).**

SN 85-097,479. GANGHUT LTD, LENZIE, UNITED KINGDOM, FILED 7-31-2010.

# K-box

THE MARK CONSISTS OF STANDARD CHARACTERS WITHOUT CLAIM TO ANY PARTICULAR FONT, STYLE, SIZE, OR COLOR.

PRIORITY CLAIMED UNDER SEC. 44(D) ON UNITED KINGDOM APPLICATION NO. REF201051611, FILED 7-30-2010.

FOR AUDIO EQUIPMENT FOR VEHICLES, NAMELY, STEREOS, SPEAKERS, AMPLIFIERS, EQUALIZERS, CROSSOVERS AND SPEAKER HOUSINGS; AUDIO SPEAKERS; LOUD SPEAKER SYSTEMS; LOUD SPEAKERS; WIRELESS INDOOR AND OUTDOOR SPEAKERS (U.S. CLS. 21, 23, 26, 36 AND 38).

FIRST USE 5-1-2009; IN COMMERCE 5-1-2009.  
IRA J. GOODSAD, EXAMINING ATTORNEY

SN 85-098,252. BANOM, INC., WAYNE, PA. FILED 8-2-2010.

# A NEW CUT-RESISTANT FIBER

THE MARK CONSISTS OF STANDARD CHARACTERS WITHOUT CLAIM TO ANY PARTICULAR FONT, STYLE, SIZE, OR COLOR.

OWNER OF U.S. REG. NO. 3,529,499.

NO CLAIM IS MADE TO THE EXCLUSIVE RIGHT TO USE "CUT-RESISTANT FIBER", APART FROM THE MARK AS SHOWN.

FOR A SYNTHETIC YARN SOLD AS AN INTEGRAL COMPONENT OF PROTECTIVE CLOTHING, NAMELY, ABRASION-RESISTANT AND CUT-RESISTANT GLOVES AND SLEEVES (U.S. CLS. 21, 23, 26, 36 AND 38).

FIRST USE 6-29-2005; IN COMMERCE 6-30-2005.  
ANGELA DUONG, EXAMINING ATTORNEY

SN 85-101,170. SPERIAN RESPIRATORY PROTECTION USA, LLC, SANTA ANA, CA. FILED 8-5-2010.

# COMMCOMMAND

THE MARK CONSISTS OF STANDARD CHARACTERS WITHOUT CLAIM TO ANY PARTICULAR FONT, STYLE, SIZE, OR COLOR.

FOR RADIO COMMUNICATION DEVICE AND VOICE AMPLIFICATION DEVICE, NAMELY, A STAND ALONE COMPONENT THAT ATTACHES SECURELY TO THE FACE PIECE OF A SELF-CONTAINED BREATHING APPARATUS USED BY INDIVIDUAL FIREFIGHTERS AND FIRST RESPONDER TEAM MEMBERS (U.S. CLS. 21, 23, 26, 36 AND 38).

FIRST USE 7-1-2007; IN COMMERCE 7-1-2007.  
DAVID TOOLEY, EXAMINING ATTORNEY

**CLASS 9—(Continued).**

SN 85-101,550. THE LINUX FOUNDATION, SAN FRANCISCO, CA. FILED 8-5-2010.

# SPDX

THE MARK CONSISTS OF STANDARD CHARACTERS WITHOUT CLAIM TO ANY PARTICULAR FONT, STYLE, SIZE, OR COLOR.

FOR DOWNLOADABLE ELECTRONIC PUBLICATIONS IN THE NATURE OF INSTRUCTIONAL MATERIALS, PAMPHLETS, WHITE PAPERS, PRESENTATIONS, AND MANUALS IN THE FIELDS OF COMPUTER SOFTWARE INDUSTRY TECHNICAL STANDARDS, SPECIFICATIONS, INFORMATION TECHNOLOGY, AND SOFTWARE DEVELOPMENT; DOWNLOADABLE ELECTRONIC PUBLICATIONS IN THE NATURE OF INSTRUCTIONAL MATERIALS, PAMPHLETS, WHITE PAPERS, PRESENTATIONS, AND MANUALS IN THE FIELD OF VOLUNTARY COMPUTER SOFTWARE STANDARDS FOR SHARING LICENSE AND COMPONENT INFORMATION FOR SOFTWARE PROGRAMS FOR FACILITATING LICENSE AND OTHER POLICY COMPLIANCE; DOWNLOADABLE ELECTRONIC PUBLICATIONS, NAMELY, VOLUNTARY DATA EXCHANGE STANDARDS GUIDES THAT ENABLE SOFTWARE DEVELOPERS, COMPANIES, AND ORGANIZATIONS TO SHARE LICENSE AND COMPONENT INFORMATION AND META DATA FOR SOFTWARE PROGRAMS AND RELATED CONTENT FOR FACILITATING LICENSE AND OTHER POLICY COMPLIANCE (U.S. CLS. 21, 23, 26, 36 AND 38).  
FIRST USE 2-0-2010; IN COMMERCE 8-7-2010.  
HELENE LIWINSKI, EXAMINING ATTORNEY

SN 85-101,879. STEP-HEAR, TEL AVIV 67443, ISRAEL, FILED 8-6-2010.

# CALL-HEAR

THE MARK CONSISTS OF STANDARD CHARACTERS WITHOUT CLAIM TO ANY PARTICULAR FONT, STYLE, SIZE, OR COLOR.

FOR TELEPHONE SETS, TELEPHONE APPARATUS AND RECEIVERS, TELEPHONE TRANSMITTERS, INTERCOMS, PAGING EQUIPMENT, PERIPHERAL COMPONENT INTERFACE PCI HARDWARE, MICROPHONES FOR COMMUNICATION DEVICES AND GPS/GSM TRACKING DEVICES, AND INTERCOMS (U.S. CLS. 21, 23, 26, 36 AND 38).  
LINDA POWELL, EXAMINING ATTORNEY

**CLASS 9—(Continued).**

SN 85-102,807. AGILENT TECHNOLOGIES, INC., SANTA CLARA, CA. FILED 8-9-2010.

# MXE

THE MARK CONSISTS OF STANDARD CHARACTERS WITHOUT CLAIM TO ANY PARTICULAR FONT, STYLE, SIZE, OR COLOR.

FOR ELECTRONIC TEST AND MEASUREMENT EQUIPMENT, NAMELY, EMI (ELECTROMAGNETIC INTERFERENCE) RECEIVERS, SPECTRUM ANALYZERS AND EMC (ELECTROMAGNETIC COMPLIANCE) PRODUCTS, NAMELY, EMI RECEIVERS FOR TESTING ELECTROMAGNETIC COMPLIANCE AND MAKING CONDUCTIVE EMISSION MEASUREMENTS (U.S. CLS. 21, 23, 26, 36 AND 38).  
JULIE GUTTADAURO, EXAMINING ATTORNEY

SN 85-105,334. ASI BUSINESS SOLUTIONS, INC., KING OF PRUSSIA, PA. FILED 8-11-2010.

# iPharmaToday

THE MARK CONSISTS OF STANDARD CHARACTERS WITHOUT CLAIM TO ANY PARTICULAR FONT, STYLE, SIZE, OR COLOR.

FOR COMPUTER APPLICATION SOFTWARE FOR MOBILE PHONES AND PORTABLE ELECTRONIC DEVICES USED FOR DATA MANAGEMENT AND ANALYSIS IN THE FIELD OF PHARMACEUTICAL SALES (U.S. CLS. 21, 23, 26, 36 AND 38).  
FIRST USE 5-1-2010; IN COMMERCE 5-1-2010.  
KELLY BOULTON, EXAMINING ATTORNEY

SN 85-105,754. ADEUNIS-RF, CROLLES, FRANCE, FILED 8-12-2010.

# VOKKERO

THE MARK CONSISTS OF STANDARD CHARACTERS WITHOUT CLAIM TO ANY PARTICULAR FONT, STYLE, SIZE, OR COLOR.

OWNER OF FRANCE REG. NO. 093667469, DATED 7-28-2009, EXPIRES 7-28-2019.

FOR APPARATUS FOR RECORDING, TRANSMISSION, REPRODUCTION OR PROCESSING OF SOUND AND IMAGES, ELECTRICAL, ELECTRONIC, COMPUTER COMMUNICATION DEVICES, ELECTRICAL, ELECTRONIC, COMPUTER, MULTI-USER, HAND-FREE COMMUNICATION DEVICES, INTENDED TO BE USED IN NOISY ENVIRONMENTS (U.S. CLS. 21, 23, 26, 36 AND 38).  
DOMINIC J. FERRAIUOLO, EXAMINING ATTORNEY



**CLASS 9—(Continued).**

SN 85-107,381. TOBI PRODUCTS, INC., SANTA BARBARA, CA. FILED 8-13-2010.

**TOBI PLATINUM**

THE MARK CONSISTS OF STANDARD CHARACTERS WITHOUT CLAIM TO ANY PARTICULAR FONT, STYLE, SIZE, OR COLOR.

OWNER OF U.S. REG. NO. 3,280,946.  
NO CLAIM IS MADE TO THE EXCLUSIVE RIGHT TO USE "PLATINUM", APART FROM THE MARK AS SHOWN, FOR FABRIC STEAMERS; GARMENT STEAMERS (U.S. CLS. 21, 23, 26, 36 AND 38).  
INGA ERVIN, EXAMINING ATTORNEY

SN 85-107,599. CISCO TECHNOLOGY, INC., SAN JOSE, CA. FILED 8-13-2010.

**CISCO FINESSE**

THE MARK CONSISTS OF STANDARD CHARACTERS WITHOUT CLAIM TO ANY PARTICULAR FONT, STYLE, SIZE, OR COLOR.

OWNER OF U.S. REG. NOS. 3,709,076, 3,747,597 AND 3,759,451.  
FOR COMPUTER SOFTWARE FOR CUSTOMER SUPPORT, CUSTOMER SERVICE MANAGEMENT AND TECHNICAL SUPPORT, NAMELY, SOFTWARE TO ENABLE CUSTOMER SERVICE REPRESENTATIVES TO ACCESS SOFTWARE APPLICATIONS AND INFORMATION FOR RESPONDING TO CUSTOMER SUPPORT INQUIRIES; COMPUTER SOFTWARE FOR CUSTOMER SUPPORT, CUSTOMER SERVICE MANAGEMENT AND TECHNICAL SUPPORT, NAMELY, SOFTWARE FOR USE IN PROVIDING CUSTOMER INTERACTION MANAGEMENT; CUSTOMER CARE OPERATIONS SOFTWARE, NAMELY, SOFTWARE FOR MANAGING, HANDLING, AND TRACKING CUSTOMER CALLS AND RESPONSES AND CUSTOMER SUPPORT; COMMUNICATION SOFTWARE FOR CUSTOMER SERVICE AGENTS (U.S. CLS. 21, 23, 26, 36 AND 38).  
DOMINIC FATHY, EXAMINING ATTORNEY

**CLASS 9—(Continued).**

SN 85-108,792. TOBIN, DAVID, JACOB, DBA SCRAPJACK, STUDIO CITY, CA. FILED 8-16-2010.

**audiojack**

THE MARK CONSISTS OF STANDARD CHARACTERS WITHOUT CLAIM TO ANY PARTICULAR FONT, STYLE, SIZE, OR COLOR.

FOR DIGITAL MEDIA, NAMELY, AUDIO FILES DOWNLOADABLE IN NATURE AND ALSO RECORDED ON CDS FEATURING SOUND EFFECTS; DIGITAL MUSIC DOWNLOADABLE FROM THE INTERNET; DOWNLOADABLE MP3 FILES AND MP3 RECORDINGS FEATURING SOUND EFFECTS (U.S. CLS. 21, 23, 26, 36 AND 38).

FIRST USE 6-1-2008; IN COMMERCE 11-12-2008.  
COURTNEY ALVAREZ, EXAMINING ATTORNEY

SN 85-109,461. PAL, RAVEEN, COURTICE, ONATRIO, CANADA, FILED 8-17-2010.

**CHURCHPAL**

THE MARK CONSISTS OF STANDARD CHARACTERS WITHOUT CLAIM TO ANY PARTICULAR FONT, STYLE, SIZE, OR COLOR.

FOR DOWNLOADABLE COMPUTER SOFTWARE FOR ACCOUNTING AND CHURCH MANAGEMENT (U.S. CLS. 21, 23, 26, 36 AND 38).

FIRST USE 1-0-2000; IN COMMERCE 1-0-2000.  
EMILY CHUO, EXAMINING ATTORNEY

SN 85-111,019. DIGITENNA, LLC, OOSTBURG, WI. FILED 8-19-2010.

**Vii**

THE MARK CONSISTS OF STANDARD CHARACTERS WITHOUT CLAIM TO ANY PARTICULAR FONT, STYLE, SIZE, OR COLOR.

FOR ANTENNAE; ANTENNAS; ANTENNAS FOR RADIO, FOR TELEVISION; CAR ANTENNAE; ELECTRONIC EQUIPMENT, NAMELY, TRANSFORMERS, BALUNS, CABLES USED IN CONNECTION WITH COMPUTERS, COMPUTER PERIPHERAL DEVICES, TELEVISIONS, AUDIO-VIDEO EQUIPMENT, CLOSED-CIRCUIT TV EQUIPMENT AND TELECOMMUNICATION EQUIPMENT (U.S. CLS. 21, 23, 26, 36 AND 38).

FIRST USE 7-8-2010; IN COMMERCE 7-8-2010.  
MARY ROSSMAN, EXAMINING ATTORNEY

**CLASS 9—(Continued).**

SN 85-111,872. MGAME CORPORATION, SEOUL, REPUBLIC OF KOREA, FILED 8-19-2010.

# ARGO

THE MARK CONSISTS OF STANDARD CHARACTERS WITHOUT CLAIM TO ANY PARTICULAR FONT, STYLE, SIZE, OR COLOR.

FOR GAME SOFTWARE, COMPUTER GAME PROGRAMS, RECORDED COMPUTER SOFTWARE, NAMELY, SOFTWARE FOR COMPUTER GAMES RECORDED ON COMPUTER MEDIA (U.S. CLS. 21, 23, 26, 36 AND 38).

MATTHEW EINSTEIN, EXAMINING ATTORNEY

---

SN 85-115,924. NOVELL, INC., PROVO, UT. FILED 8-25-2010.

# NOVELL

THE MARK CONSISTS OF STANDARD CHARACTERS WITHOUT CLAIM TO ANY PARTICULAR FONT, STYLE, SIZE, OR COLOR.

OWNER OF U.S. REG. NOS. 2,169,906, 2,518,093 AND OTHERS.

THE WORDING "NOVELL" HAS NO MEANING IN A FOREIGN LANGUAGE.

FOR COMPUTER PROGRAMS FOR CREATING COMPUTER NETWORKS BY CONNECTING COMPUTERS VIA LOCAL AREA NETWORKS, WIDE AREA NETWORKS AND/OR THE INTERNET, FOR GRID AND UTILITY COMPUTING THROUGH COMPUTER NETWORKS, INTRANETS AND THE INTERNET FOR OPERATING COMPUTER NETWORKS, BUILDING DISTRIBUTED APPLICATIONS OF OTHERS, CONFIGURING AND MANAGING SECURITY AND IDENTITY PROTOCOLS ON PHYSICAL AND VIRTUAL COMPUTER NETWORKS, AND FOR COMPUTER RESOURCE CAPACITY AND UTILIZATION PROFILING, ANALYSIS AND PLANNING OF A PHYSICAL, VIRTUAL AND CLOUD COMPUTING NETWORK INFRASTRUCTURE AND ENVIRONMENTS (U.S. CLS. 21, 23, 26, 36 AND 38).

FIRST USE 9-15-1983; IN COMMERCE 9-15-1983.

BILL DAWE, EXAMINING ATTORNEY

**CLASS 9—(Continued).**

SN 85-119,893. PULSE TRACER, INC., SAN FRANCISCO, CA. FILED 8-31-2010.

# Basis

THE MARK CONSISTS OF STANDARD CHARACTERS WITHOUT CLAIM TO ANY PARTICULAR FONT, STYLE, SIZE, OR COLOR.

FOR COMPUTER HARDWARE AND SOFTWARE THAT PROVIDE WEB-BASED ACCESS TO APPLICATIONS AND SERVICES THROUGH A WEB OPERATING SYSTEM OR PORTAL INTERFACE FOR THE PURPOSE OF PERSONAL HEALTH MONITORING (U.S. CLS. 21, 23, 26, 36 AND 38).

GINA HAYES, EXAMINING ATTORNEY

---

SN 85-120,919. MUNRO & ASSOCIATES, INC., TROY, MI. FILED 9-1-2010.

# DP MRL

THE MARK CONSISTS OF STANDARD CHARACTERS WITHOUT CLAIM TO ANY PARTICULAR FONT, STYLE, SIZE, OR COLOR.

NO CLAIM IS MADE TO THE EXCLUSIVE RIGHT TO USE "MRL", APART FROM THE MARK AS SHOWN.

FOR COMPUTER SOFTWARE FOR SUPPORTING THE DEVELOPMENT OF PRODUCT DESIGNS FROM CREATION THROUGH PRODUCTION AND FOR THE SUPPORTING THE ASSESSMENT OF MANUFACTURING CAPABILITIES FOR PRODUCTS AND PROCESSES (U.S. CLS. 21, 23, 26, 36 AND 38).

FIRST USE 10-5-2009; IN COMMERCE 10-5-2009.

REBECCA POVARCHUK, EXAMINING ATTORNEY

**CLASS 9—(Continued).**

SN 85-121,435. CHOKHALINGAM, PALAYAMKOTTAI M, AUBURN HILLS, MI. FILED 9-2-2010.



THE COLOR(S) ORANGE AND WHITE IS/ARE CLAIMED AS A FEATURE OF THE MARK.

THE MARK CONSISTS OF AN ORANGE COLOR ON THE MARK, WITH THE LETTER "L" AND "F" BIGGER THAN REST OF THE CHARACTERS. THE CHARACTERS ARE UNEVEN IN SIZE. THE LETTER "I" AND "Y" ARE ON THE SAME BASE ELEVATION. THE LETTER "L", "C" AND "F" ARE ELEVATED ABOVE "I" AND "Y" FROM THE BASE. THE LETTER "O" IS ELEVATED ABOVE THE REST FROM THE BASE. TO THE LEFT IS A SQUARE WITH A FANCIFUL DESIGN OF A PERSON WITH A WHITE BUNNY AT THE FACE.

FOR COMPUTER PROGRAMS FOR LOCATION BASED SERVICES (U.S. CLS. 21, 23, 26, 36 AND 38).

FIRST USE 3-29-2008; IN COMMERCE 3-29-2008.

JACQUELINE A. LAVINE, EXAMINING ATTORNEY

SN 85-124,306. VANILLA BEAN SERVICES INC., SAN CARLOS, CA. FILED 9-7-2010.

**PLAIN VANILLA**

THE MARK CONSISTS OF STANDARD CHARACTERS WITHOUT CLAIM TO ANY PARTICULAR FONT, STYLE, SIZE, OR COLOR.

FOR DOWNLOADABLE COMPUTER SOFTWARE FOR USE AS A SPREADSHEET IN THE FIELDS OF PERSONAL FINANCIAL MANAGEMENT AND COOKING RECIPE MANAGEMENT (U.S. CLS. 21, 23, 26, 36 AND 38).

MICHAEL LITZAU, EXAMINING ATTORNEY

**CLASS 9—(Continued).**

SN 85-126,422. AINSWORTH GAME TECHNOLOGY, NEWINGTON, AUSTRALIA, FILED 9-9-2010.

**Super A560**

THE MARK CONSISTS OF STANDARD CHARACTERS WITHOUT CLAIM TO ANY PARTICULAR FONT, STYLE, SIZE, OR COLOR.

OWNER OF U.S. REG. NOS. 3,598,640 AND 3,796,692.

FOR COMPUTER SOFTWARE AND FIRMWARE FOR GAMES OF CHANCE ON ANY COMPUTERIZED PLATFORM, INCLUDING DEDICATED GAMING CONSOLES, VIDEO BASED SLOT MACHINES, REEL BASED SLOT MACHINES, AND VIDEO LOTTERY TERMINALS (U.S. CLS. 21, 23, 26, 36 AND 38).

ELLEN BURNS, EXAMINING ATTORNEY

SN 85-126,814. MONOBIND, INC., LAKE FOREST, CA. FILED 9-10-2010.

**LuMatic**

THE MARK CONSISTS OF STANDARD CHARACTERS WITHOUT CLAIM TO ANY PARTICULAR FONT, STYLE, SIZE, OR COLOR.

FOR LABORATORY INSTRUMENTS, NAMELY, A LUMINOMETER USED TO MEASURE RELATIVE LIGHT UNITS PRODUCED BY CHEMILUMINESCENCE BASED IMMUNOASSAYS (U.S. CLS. 21, 23, 26, 36 AND 38).

FIRST USE 7-27-2010; IN COMMERCE 7-27-2010.

ROBERT C. CLARK JR., EXAMINING ATTORNEY

SN 85-130,276. MOTOROLA TRADEMARK HOLDINGS, LLC, LIBERTYVILLE, IL. FILED 9-15-2010.

**FLYER**

THE MARK CONSISTS OF STANDARD CHARACTERS WITHOUT CLAIM TO ANY PARTICULAR FONT, STYLE, SIZE, OR COLOR.

FOR CELLULAR PHONES; CELLULAR PHONES WITH ELECTRONIC MESSAGING CAPABILITIES; CELLULAR PHONES WITH DIGITAL CAMERA AND VIDEO CAMERA CAPABILITIES; CELLULAR PHONES WITH MP3, AUDIO, AND VIDEO PLAYER CAPABILITIES; CELLULAR PHONES WITH ELECTRONIC GAME CAPABILITIES; CELLULAR PHONES WITH NAVIGATION AND GLOBAL POSITIONING (GPS) CAPABILITIES; CELLULAR TELEPHONE HEADSETS; CELLULAR TELEPHONE EAR BUDS; CELLULAR PHONE BATTERIES; BATTERY CHARGERS AND POWER ADAPTORS (U.S. CLS. 21, 23, 26, 36 AND 38).

THEODORE MCBRIDE, EXAMINING ATTORNEY

**CLASS 9—(Continued).**

SN 85-130,375. TOM.COM ENTERPRISES LIMITED, TORTOLA, BR. VIRGIN ISLANDS, FILED 9-15-2010.



THE MARK CONSISTS OF THE WORD "TOM" IN SPECIAL LETTERS AND A REPRESENTATION OF A 5 POINTED STAR DESIGN.

FOR PRE-RECORDED VIDEO COMPACT DISCS AND PRE-RECORDED COMPACT DISCS FEATURING MOVIES, TELEVISION PROGRAMS, SPORTING EVENTS, TRAVEL AND TOURISM, FASHION, FOOD AND DRINK, WINE, COOKING INSTRUCTION, SELF-IMPROVEMENT, HEALTH, WOMEN'S ISSUES, INTERNET RELATED INFORMATION, CHILD RAISING, FICTION AND NON-FICTION BOOKS, COMICS, AUDIO-VIDEO PRODUCTS, AUTOMOBILES, HOME IMPROVEMENT, AND CURRENT AFFAIRS (U.S. CLS. 21, 23, 26, 36 AND 38).

AMY HELLA, EXAMINING ATTORNEY

SN 85-135,511. ROCHFORD, ANNE, LANCASTER, PA. FILED 9-22-2010.

## Outlaw by Design

THE MARK CONSISTS OF STANDARD CHARACTERS WITHOUT CLAIM TO ANY PARTICULAR FONT, STYLE, SIZE, OR COLOR.

NO CLAIM IS MADE TO THE EXCLUSIVE RIGHT TO USE "DESIGN", APART FROM THE MARK AS SHOWN.

FOR DOWNLOADABLE COMPUTER GRAPHICS (U.S. CLS. 21, 23, 26, 36 AND 38).

FIRST USE 12-0-2000; IN COMMERCE 6-0-2002.

DOMINICK J. SALEMI, EXAMINING ATTORNEY

**CLASS 9—(Continued).**

SN 85-136,069. RMO, INC., DENVER, CO. FILED 9-22-2010.

## JOE CEPH

THE MARK CONSISTS OF STANDARD CHARACTERS WITHOUT CLAIM TO ANY PARTICULAR FONT, STYLE, SIZE, OR COLOR.

OWNER OF U.S. REG. NOS. 2,576,715 AND 3,748,561.

FOR COMPUTER SOFTWARE PROGRAM FOR USE IN PROVIDING DIAGNOSIS AND TREATMENT PLANS IN THE FIELD OF ORTHODONTIA, INCLUDING ONSCREEN DIGITIZING, SUPERIMPOSITION, AND PATIENT ANALYSIS; COMPUTER SOFTWARE PROGRAM FOR USE IN FACIAL GROWTH FORECASTING IN THE ORTHODONTIC FIELD, INCLUDING ONSCREEN DIGITIZING, SUPERIMPOSITION, AND PATIENT ANALYSIS (U.S. CLS. 21, 23, 26, 36 AND 38).

ANDREA BUTLER, EXAMINING ATTORNEY

SN 85-136,113. NATHAN KREITZER, DBA QUIRE OF VOYCES, SANTA BARBARA, CA. FILED 9-22-2010.

## quire of voyces

THE MARK CONSISTS OF STANDARD CHARACTERS WITHOUT CLAIM TO ANY PARTICULAR FONT, STYLE, SIZE, OR COLOR.

FOR AUDIO AND VIDEO RECORDINGS FEATURING MUSIC AND ARTISTIC PERFORMANCES (U.S. CLS. 21, 23, 26, 36 AND 38).

STEPHANIE ALI, EXAMINING ATTORNEY

SN 85-136,533. PROCESS QUERY SYSTEMS, LLC, LEBA-  
NON, NH. FILED 9-23-2010.

## FlowTraq

THE MARK CONSISTS OF STANDARD CHARACTERS WITHOUT CLAIM TO ANY PARTICULAR FONT, STYLE, SIZE, OR COLOR.

FOR COMPUTER SOFTWARE FOR MONITORING, FORENSICS, SECURITY, ALERTING, AND REPORTING ON DATA AND RECORDS FROM NETWORK DEVICES AND NETWORK TRAFFIC (U.S. CLS. 21, 23, 26, 36 AND 38).

JOHN KELLY, EXAMINING ATTORNEY

**CLASS 9—(Continued).**

SN 85-136,540. PROCESS QUERY SYSTEMS, LLC, LEBANON, NH. FILED 9-23-2010.

# ProQueSys

THE MARK CONSISTS OF STANDARD CHARACTERS WITHOUT CLAIM TO ANY PARTICULAR FONT, STYLE, SIZE, OR COLOR.

FOR COMPUTER NETWORK MONITORING SOFTWARE FOR NETWORK SECURITY AND ANALYSIS; COMPUTER NETWORK TRAFFIC FORENSICS SOFTWARE FOR NETWORK SECURITY AND ANALYSIS; COMPUTER NETWORK SECURITY MANAGEMENT SOFTWARE FOR NETWORK SECURITY AND ANALYSIS (U.S. CLS. 21, 23, 26, 36 AND 38).

JOHN KELLY, EXAMINING ATTORNEY

**CLASS 9—(Continued).**

SN 85-141,611. PEOPLEGO INC., SEATTLE, WA. FILED 9-30-2010.

# iHear

THE MARK CONSISTS OF STANDARD CHARACTERS WITHOUT CLAIM TO ANY PARTICULAR FONT, STYLE, SIZE, OR COLOR.

FOR COMPUTER APPLICATION SOFTWARE FOR MOBILE DEVICES, NAMELY, SOFTWARE FOR PEOPLE WHO WANT TO HEAR GEOTAGGED AUDIO RELEVANT TO THEIR LOCATION (U.S. CLS. 21, 23, 26, 36 AND 38).

FIRST USE 10-15-2010; IN COMMERCE 1-12-2011.  
DOMINICK J. SALEMI, EXAMINING ATTORNEY

SN 85-140,397. PRETTY FLUFFY CHICKEN PRODUCTIONS, LLC, EDINA, MN. FILED 9-28-2010.

# EAT YOUR DRINK

THE MARK CONSISTS OF STANDARD CHARACTERS WITHOUT CLAIM TO ANY PARTICULAR FONT, STYLE, SIZE, OR COLOR.

NO CLAIM IS MADE TO THE EXCLUSIVE RIGHT TO USE "DRINK", APART FROM THE MARK AS SHOWN.

FOR COMPUTER APPLICATION SOFTWARE FOR MOBILE PHONES, PORTABLE MEDIA PLAYERS, AND HANDHELD COMPUTERS, NAMELY, SOFTWARE FOR DOWNLOADING CALENDARS, JOURNALS, RECIPES AND INFORMATION IN THE FIELDS OF ENTERTAINING, COCKTAILS, COCKTAIL RECIPES, PHOTOS, AND MENU PLANNING (U.S. CLS. 21, 23, 26, 36 AND 38).

WON TEAK OH, EXAMINING ATTORNEY

SN 85-142,135. BARJAN LLC, ROCK ISLAND, IL. FILED 9-30-2010.

# ZURICH

THE MARK CONSISTS OF STANDARD CHARACTERS WITHOUT CLAIM TO ANY PARTICULAR FONT, STYLE, SIZE, OR COLOR.

FOR DVD PLAYERS; EARPHONES; HEADPHONES; MEDIA PLAYERS; PORTABLE DVD PLAYERS; PORTABLE MEDIA PLAYERS; TELEVISIONS (U.S. CLS. 21, 23, 26, 36 AND 38).

FIRST USE 9-3-2010; IN COMMERCE 9-3-2010.  
SKYE YOUNG, EXAMINING ATTORNEY

SN 85-141,072. NEVA ENTERPRISES, INC., SALT LAKE CITY, UT. FILED 9-29-2010.

# VIRAGE

THE MARK CONSISTS OF STANDARD CHARACTERS WITHOUT CLAIM TO ANY PARTICULAR FONT, STYLE, SIZE, OR COLOR.

THE ENGLISH TRANSLATION OF THE WORD "VIRAGE" IN THE MARK IS TURN OR BEND.

FOR SUN GLASSES AND SKI GOGGLES (U.S. CLS. 21, 23, 26, 36 AND 38).

FIRST USE 12-5-2006; IN COMMERCE 12-5-2006.  
JENNIFER VASQUEZ, EXAMINING ATTORNEY

SN 85-142,277. BRIAN P. HAGERTY, PHOENIX, AZ. FILED 9-30-2010.

# SPIDER

THE MARK CONSISTS OF STANDARD CHARACTERS WITHOUT CLAIM TO ANY PARTICULAR FONT, STYLE, SIZE, OR COLOR.

FOR SUNGLASSES, EYEWEAR, EYEGLASS FRAMES, SUNGLASS FRAMES, EYEGLASS LENSES, EYEWEAR ACCESSORIES, NAMELY, EYEGLASS CASES AND EYEGLASS CHAINS (U.S. CLS. 21, 23, 26, 36 AND 38).

DOMINIC J. FERRAIUOLO, EXAMINING ATTORNEY

**CLASS 9—(Continued).**

SN 85-142,427. SHAVLIK TECHNOLOGIES, LLC, ROSEVILLE, MN. FILED 9-30-2010.

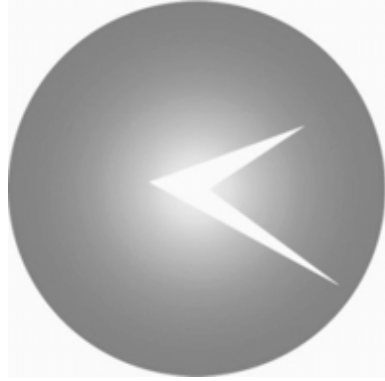

THE MARK CONSISTS OF A SHADED CIRCULAR DESIGN ENCOMPASSING A SHARPLY ANGLED CHEVRON.

FOR DOWNLOADABLE COMPUTER SOFTWARE FOR USE IN TRACKING AND MONITORING PHYSICAL COMPUTERS, VIRTUAL MACHINES, COMPUTER SOFTWARE, COMPUTER SOFTWARE PATCHES AND OFFLINE SERVERS ON COMPUTER NETWORKS; AND COMPUTER SOFTWARE USED FOR IT SYSTEMS MANAGEMENT (U.S. CLS. 21, 23, 26, 36 AND 38).

FIRST USE 5-0-2010; IN COMMERCE 5-0-2010.  
BENJAMIN OKEKE, EXAMINING ATTORNEY

SN 85-142,715. SOCIAL GAMES CORP., ENCINITAS, CA, CA. FILED 10-1-2010.

**MAKING FRIENDS FROM ALL  
AROUND**

THE MARK CONSISTS OF STANDARD CHARACTERS WITHOUT CLAIM TO ANY PARTICULAR FONT, STYLE, SIZE, OR COLOR.

FOR APPARATUS FOR SPEECH RECORDING AND REPLAYING; CHILDREN'S EDUCATIONAL SOFTWARE; COMPUTER GAME CARTRIDGES; COMPUTER GAME CARTRIDGES AND DISCS; COMPUTER GAME CASSETTES; COMPUTER GAME CONSOLES FOR USE WITH AN EXTERNAL DISPLAY SCREEN OR MONITOR; COMPUTER GAME DISCS; COMPUTER GAME EQUIPMENT, NAMELY, DISCS; COMPUTER GAME JOYSTICKS; COMPUTER GAME PROGRAMS; COMPUTER GAME PROGRAMS DOWNLOADABLE VIA THE INTERNET; COMPUTER GAME PROGRAMS, CARTRIDGES, AND CASSETTES; COMPUTER GAME SOFTWARE; COMPUTER GAME SOFTWARE DOWNLOADABLE FROM A GLOBAL COMPUTER NETWORK; COMPUTER GAME SOFTWARE FOCUSING ON ACHIEVING A SET OF GOALS, POSITIONS, OWNERSHIP, AND CREDENTIALS, AND PROFESSIONAL AND SOCIAL STATUS, AND GOOD FORTUNE NECESSARY TO SUCCEED PROFESSIONALLY AND PERSONALLY, AND NOT REFERRING EITHER TO A GROUP OF SOFTWARE FOR USE IN COMMERCE OR TO A GROUP OF OFFICES; COMPUTER GAME SOFTWARE FOR PERSONAL COMPUTERS AND HOME VIDEO GAME CONSOLES; COMPUTER GAME SOFTWARE FOR USE ON MOBILE AND CELLULAR PHONES; COMPUTER GAME SOFTWARE FOR USE WITH PERSONAL COMPUTERS, HOME VIDEO GAME CONSOLES USED WITH TELEVISIONS, AND FOR ARCADE-BASED VIDEO GAME CONSOLES; COMPUTER HARDWARE AND COMPUTER PERIPHERAL DEVICES; COMPUTER

**CLASS 9—(Continued).**

HARDWARE AND COMPUTER SOFTWARE PROGRAMS FOR THE INTEGRATION OF TEXT, AUDIO, GRAPHICS, STILL IMAGES AND MOVING PICTURES INTO AN INTERACTIVE DELIVERY FOR MULTIMEDIA APPLICATIONS; COMPUTER HARDWARE AND SOFTWARE USED FOR THE CONTROL OF VOICE CONTROLLED INFORMATION AND COMMUNICATION DEVICES; COMPUTER PROGRAMS FOR VIDEO AND COMPUTER GAMES; COMPUTER SOFTWARE FEATURING TRAINING IN THE FIELD OF TREATMENT FOR ADULT AND CHILDREN'S SOCIAL DELAY, SPEECH DELAY, AUTISM, DEVELOPMENTAL DELAY, SPEECH THERAPY, PERVASIVE DEVELOPMENTAL DISORDER (PDD), PERVASIVE DEVELOPMENTAL DISORDER NOT OTHERWISE SPECIFIED (PDD-NOS), ASPERGER'S SYNDROME, ATTENTION DEFICIT DISORDER, (ADD), ATTENTION DEFICIT HYPERACTIVITY DISORDER (ADHD), SOCIAL IMPAIRMENT, STROKE, BRAIN DAMAGE AND PHYSICAL REHABILITATION; COMPUTER SOFTWARE AND COMPUTER HARDWARE FOR USE IN LANGUAGE LOCALIZATION, BY MEANS OF LANGUAGE TRANSLATION, SUBTITLING, DUBBING, CLOSED CAPTIONING AND TELETEXT FOR FEATURE FILMS, TELEVISION PROGRAMS, VIDEOS AND DIGITAL MEDIA IN GENERAL; COMPUTER-GAMING SOFTWARE; DOWNLOADABLE COMPUTER GAME PROGRAMS; DOWNLOADABLE COMPUTER GAME SOFTWARE VIA A GLOBAL COMPUTER NETWORK AND WIRELESS DEVICES; DOWNLOADABLE COMPUTER PROGRAMS FEATURING POSITIONABLE GAME PIECE FIGURES FOR USE IN THE FIELD OF COMPUTER GAMES; GAME CONTROLLERS FOR COMPUTER GAMES; INTERACTIVE GAME PROGRAMS; INTERACTIVE GAME SOFTWARE; INTERACTIVE MULTIMEDIA COMPUTER GAME PROGRAM; COMPUTER SOFTWARE FOR HEALTH CARE PROFESSIONALS FOR USE IN LANGUAGE AND SOCIAL SKILLS REHABILITATION FOR PATIENTS WITH ADULT AND CHILDREN'S SOCIAL DELAY, SPEECH DELAY, AUTISM, DEVELOPMENTAL DELAY, SPEECH THERAPY, PERVASIVE DEVELOPMENTAL DISORDER (PDD), PERVASIVE DEVELOPMENTAL DISORDER NOT OTHERWISE SPECIFIED (PDD-NOS), ASPERGER'S SYNDROME, ATTENTION DEFICIT DISORDER, (ADD), ATTENTION DEFICIT HYPERACTIVITY DISORDER (ADHD), SOCIAL IMPAIRMENT, STROKE, AND BRAIN DAMAGE; INTERACTIVE VIDEO GAMES OF VIRTUAL REALITY COMPRISED OF COMPUTER HARDWARE FOR USE WITH AN EXTERNAL MONITOR AND SOFTWARE; RECORDED COMPUTER GAME PROGRAMS; VIDEO AND COMPUTER GAME PROGRAMS; WIRELESS COMMUNICATION DEVICE FEATURING VOICE, DATA AND IMAGE TRANSMISSION INCLUDING VOICE, TEXT AND PICTURE MESSAGING, A VIDEO AND STILL IMAGE CAMERA, ALSO FUNCTIONAL TO PURCHASE MUSIC, GAMES, VIDEO AND SOFTWARE APPLICATIONS OVER THE AIR FOR DOWNLOADING TO THE DEVICE (U.S. CLS. 21, 23, 26, 36 AND 38).

MARLENE BELL, EXAMINING ATTORNEY

**CLASS 9—(Continued).**

SN 85-144,098. MARANDA ENTERPRISES, MEQUON, WI.  
FILED 10-4-2010.

# Ice Vest

THE MARK CONSISTS OF STANDARD CHARACTERS WITHOUT CLAIM TO ANY PARTICULAR FONT, STYLE, SIZE, OR COLOR.

NO CLAIM IS MADE TO THE EXCLUSIVE RIGHT TO USE "VEST", APART FROM THE MARK AS SHOWN.

SEC. 2(F).

FOR PROTECTIVE ACTIVE COOLING VESTS, SHIRTS AND JACKETS WITH LIQUID INFUSED COMPARTMENTS TO PREVENT INJURY DUE TO OVERHEATING (U.S. CLS. 21, 23, 26, 36 AND 38).

FIRST USE 8-1-2004; IN COMMERCE 8-1-2004.

ANTHONY RINKER, EXAMINING ATTORNEY

---

SN 85-144,978. POLARIS INDUSTRIES INC., MEDINA, MN.  
FILED 10-5-2010.

# DIGITAL WRENCH

THE MARK CONSISTS OF STANDARD CHARACTERS WITHOUT CLAIM TO ANY PARTICULAR FONT, STYLE, SIZE, OR COLOR.

NO CLAIM IS MADE TO THE EXCLUSIVE RIGHT TO USE "DIGITAL", APART FROM THE MARK AS SHOWN.

FOR COMPUTER SOFTWARE AND COMPUTER INTERFACE CABLES SOLD AS A UNIT AND USED AS A DIAGNOSTIC TOOL FOR ELECTRONIC FUEL INJECTION SYSTEMS (U.S. CLS. 21, 23, 26, 36 AND 38).

FIRST USE 12-0-2003; IN COMMERCE 12-0-2003.

VIVIAN MICZNIK FIRST, EXAMINING ATTORNEY

---

SN 85-145,572. SHAW FAMILY ARCHIVES, LTD., NEW YORK, NY. FILED 10-5-2010.

# SAM SHAW

THE MARK CONSISTS OF STANDARD CHARACTERS WITHOUT CLAIM TO ANY PARTICULAR FONT, STYLE, SIZE, OR COLOR.

THE NAME(S), PORTRAIT(S), AND/OR SIGNATURE(S) SHOWN IN THE MARK DOES NOT IDENTIFY A PARTICULAR LIVING INDIVIDUAL.

FOR EYEWEAR AND ASSOCIATED GOODS, NAMELY, EYEGLASSES, SUNGLASSES, EYEGLASS FRAMES, SPECTACLE CARRYING CASES AND POUCHES (U.S. CLS. 21, 23, 26, 36 AND 38).

BRIAN PINO, EXAMINING ATTORNEY

**CLASS 9—(Continued).**

SN 85-145,583. SHAW FAMILY ARCHIVES, LTD., NEW YORK, NY. FILED 10-5-2010.

# MARILYN BY SAM SHAW

THE MARK CONSISTS OF STANDARD CHARACTERS WITHOUT CLAIM TO ANY PARTICULAR FONT, STYLE, SIZE, OR COLOR.

THE NAME(S), PORTRAIT(S), AND/OR SIGNATURE(S) SHOWN IN THE MARK DOES NOT IDENTIFY A PARTICULAR LIVING INDIVIDUAL.

FOR EYEWEAR AND ASSOCIATED GOODS, NAMELY, EYEGLASSES, SUNGLASSES, EYEGLASS FRAMES, SPECTACLE CARRYING CASES AND POUCHES (U.S. CLS. 21, 23, 26, 36 AND 38).

BRIAN PINO, EXAMINING ATTORNEY

---

SN 85-145,987. INNOVATIVE WIRELESS TECHNOLOGIES, INC., ESCONDIDO, CA. FILED 10-6-2010.

# KELLAN

THE MARK CONSISTS OF STANDARD CHARACTERS WITHOUT CLAIM TO ANY PARTICULAR FONT, STYLE, SIZE, OR COLOR.

THE NAME "KELLAN" DOES NOT IDENTIFY A LIVING INDIVIDUAL.

FOR AUTOMATED SELF CONTAINED ELECTRONIC SURVEILLANCE DEVICES THAT CAN BE DEPLOYED TO GATHER EVIDENCE OR INTELLIGENCE IN REMOTE LOCATIONS; ELECTRONIC REGULATING AND CONTROL DEVICES FOR THE OPERATION OF LIGHT EMITTING DIODES; WIRELESS COMMUNICATION DEVICES FOR TRANSMITTING IMAGES TAKEN BY A CAMERA; WIRELESS COMMUNICATION DEVICES FOR VOICE, DATA OR IMAGE TRANSMISSION; WIRELESS CONTROLLER TO MONITOR AND CONTROL THE FUNCTIONING OF OTHER ELECTRONIC DEVICES; WIRELESS TRANSMITTERS AND RECEIVERS (U.S. CLS. 21, 23, 26, 36 AND 38).

JAY BESCH, EXAMINING ATTORNEY

**CLASS 9—(Continued).**

SN 85-146,147. GLM GLOBAL, LLC, CHANTILLY, VA. FILED 10-6-2010.



THE COLOR(S) YELLOW, BLACK, WHITE, BROWN, BEIGE AND BLACK IS/ARE CLAIMED AS A FEATURE OF THE MARK.

THE MARK CONSISTS OF THE ARTISTIC RENDERING OF THE TOP OF A HUMAN HEAD IN BEIGE AND BROWN. A THOUGHT BUBBLE EMERGES FROM THE HUMAN HEAD WITH THREE SMALL CIRCLES IN WHITE WITH A BLACK OUTLINE LEADING TO A LARGER CIRCLE IN WHITE WITH A BLACK OUTLINE. THE STYLIZED WORDS "WHAT'S ON YOUR MIND?" APPEAR IN BLACK INSIDE THE AFOREMENTIONED LARGE CIRCLE. THE FOREGOING APPEARS ON A YELLOW BACKGROUND.

FOR COMPUTER APPLICATION SOFTWARE FOR MOBILE PHONES, HANDHELD COMPUTERS, AND MOBILE COMPUTERS, NAMELY, SOFTWARE THAT ENABLES USERS TO WRITE OUT THEIR THOUGHTS AND IDEAS, TRANSMIT THEIR THOUGHTS AND IDEAS TO OTHER USERS AND POST THEIR THOUGHTS AND IDEAS ON THE SOCIAL NETWORKING WEB SITES OF OTHERS (U.S. CLS. 21, 23, 26, 36 AND 38).

JEFFREY LOOK, EXAMINING ATTORNEY

SN 85-146,249. MILLER, ROBERT H., DBA RHM COMPANY, ALBRIGHTSVILLE, PA. FILED 10-6-2010.

## Backroad Bob

THE MARK CONSISTS OF STANDARD CHARACTERS WITHOUT CLAIM TO ANY PARTICULAR FONT, STYLE, SIZE, OR COLOR.

THE NAME "BACKROAD BOB" IDENTIFIES THE PSEUDONYM OF ROBERT H. MILLER, A LIVING INDIVIDUAL WHOSE CONSENT IS OF RECORD.

FOR COMPACT DISCS FEATURING RECORDED MAGAZINE ARTICLES FEATURING INFORMATION REGARDING MOTORCYCLE TRAVEL (U.S. CLS. 21, 23, 26, 36 AND 38).

FIRST USE 1-1-1999; IN COMMERCE 2-27-2006.

KELLY TRUSILO, EXAMINING ATTORNEY

**CLASS 9—(Continued).**

SN 85-148,105. SEAGA MANUFACTURING, INC., FREEPORT, IL. FILED 10-8-2010.



OWNER OF U.S. REG. NO. 3,059,015.

NO CLAIM IS MADE TO THE EXCLUSIVE RIGHT TO USE "CAFFÈ", APART FROM THE MARK AS SHOWN.

THE MARK CONSISTS OF A STYLIZED DEPICTION OF A CUP OF COFFEE, WITH STEAM RISING FROM THE CUP, SET TO THE LEFT OF THE STYLIZED WORDING "SEAGA CAFFÈ", WITH AN INCOMPLETE OVAL SURROUNDING THE WORDS "SEAGA CAFFÈ".

THE ENGLISH TRANSLATION OF "CAFFÈ" IN THE MARK IS "COFFEE". THE TERM "SEAGA" HAS NO MEANING IN A FOREIGN LANGUAGE.

FOR VENDING MACHINES (U.S. CLS. 21, 23, 26, 36 AND 38).

FIRST USE 8-30-2010; IN COMMERCE 8-30-2010.

MICHAEL GAFFAR, EXAMINING ATTORNEY

SN 85-149,037. TSC AUTO ID TECHNOLOGY CO., LTD., TAIPEI CITY 110, TAIWAN, FILED 10-9-2010.



OWNER OF U.S. REG. NO. 2,878,868.

THE MARK CONSISTS OF THE STYLIZED LETTERS "TSC" POSITIONED ABOVE THE WORDS "CONNECTING YOUR THERMAL PRINTING NEEDS.".

FOR BAR CODE PRINTERS AND PARTS AND ACCESSORIES THEREFOR, NAMELY, BAR CODE LABEL CUTTERS, BAR CODE PRINTER KEYBOARD, AND INK-TRANSFER RIBBONS FOR USE WITH BAR CODE PRINTERS, SOLD AS UNIT THEREWITH; THERMAL PRINTERS; SCANNERS; MOBILE COMPUTERS (U.S. CLS. 21, 23, 26, 36 AND 38).

DEZMONA MIZELLE, EXAMINING ATTORNEY

SN 85-149,377. SOUTHERN STATES, LLC, HAMPTON, GA. FILED 10-11-2010.

## TRANSWITCHER

THE MARK CONSISTS OF STANDARD CHARACTERS WITHOUT CLAIM TO ANY PARTICULAR FONT, STYLE, SIZE, OR COLOR.

FOR ELECTRICAL SWITCH GEAR, NAMELY, HIGH VOLTAGE SWITCHING APPARATUSES (U.S. CLS. 21, 23, 26, 36 AND 38).

ODESSA BIBBINS, EXAMINING ATTORNEY



**CLASS 9—(Continued).**

SN 85-149,433. P.A.C. TRADING GROUP, INC., MIAMI, FL. FILED 10-11-2010.

**BOOSTER PAC**

THE MARK CONSISTS OF STANDARD CHARACTERS WITHOUT CLAIM TO ANY PARTICULAR FONT, STYLE, SIZE, OR COLOR.

FOR CAR AND HOME AUDIO AND VIDEO EQUIPMENT, NAMELY, CAR STEREOs, CAR AMPLIFIERS, CAR SPEAKERS, CAR LCD PANELS, CAR DVD PLAYERS, EQUALIZERS, CROSSOVERS, PORTABLE DVD PLAYERS, PORTABLE MP3 PLAYERS, HOME LCD AND PLASMA TELEVISION SETS, HOME DVD PLAYERS, AND HOME DVD RECORDERS (U.S. CLS. 21, 23, 26, 36 AND 38).

RAUL CORDOVA, EXAMINING ATTORNEY

SN 85-149,445. CHEMGLASS LIFE SCIENCES, LLC, VINELAND, NJ. FILED 10-11-2010.

**TOOL—FREE**

THE COLOR(S) GREEN IS/ARE CLAIMED AS A FEATURE OF THE MARK.

THE MARK CONSISTS OF THE WORDING "TOOL-FREE" IN GREEN STYLIZED LETTERS WITH THE DASH REPRESENTED BY A GREEN WRENCH.

FOR BIOREACTOR FOR CELL CULTURING; ELECTRICAL REACTORS; LABORATORY CHEMICAL REACTORS; LABORATORY PHOTOCHEMICAL REACTORS (U.S. CLS. 21, 23, 26, 36 AND 38).

HAI-LY LAM, EXAMINING ATTORNEY

SN 85-149,490. DANIEL, THOMAS, SAN MARCOS, CA. FILED 10-11-2010.

**VIVO-ID**

THE MARK CONSISTS OF STANDARD CHARACTERS WITHOUT CLAIM TO ANY PARTICULAR FONT, STYLE, SIZE, OR COLOR.

FOR COMPUTER APPLICATION SOFTWARE FOR MOBILE SMART PHONES AND HANDHELD COMPUTING DEVICES, NAMELY, SOFTWARE FOR ALLOWING USERS TO SCAN CONSUMER PRODUCTS, EVENT TICKETS, AND PRINTED ADVERTISING SO THAT THEY CAN ACCESS THE WEB TO SEEK FURTHER INFORMATION REGARDING THOSE PRODUCTS (U.S. CLS. 21, 23, 26, 36 AND 38).

BILL DAWE, EXAMINING ATTORNEY

**CLASS 9—(Continued).**

SN 85-149,686. PC TREASURES, INC., OXFORD, MI. FILED 10-11-2010.

**TREEFROG**

THE MARK CONSISTS OF STANDARD CHARACTERS WITHOUT CLAIM TO ANY PARTICULAR FONT, STYLE, SIZE, OR COLOR.

FOR PHOTOGRAPHIC ACCESSORIES, NAMELY, FLEXIBLE TRIPODS (U.S. CLS. 21, 23, 26, 36 AND 38).

STEVEN R. FINE, EXAMINING ATTORNEY

SN 85-149,947. CELLCO PARTNERSHIP, DBA VERIZON WIRELESS, BASKING RIDGE, NJ. FILED 10-11-2010.

**AIRGLOW**

THE MARK CONSISTS OF STANDARD CHARACTERS WITHOUT CLAIM TO ANY PARTICULAR FONT, STYLE, SIZE, OR COLOR.

FOR WIRELESS COMMUNICATIONS DEVICE, NAMELY, A DEVICE THAT ESTABLISHES A WIRELESS NETWORK FOR CONNECTION OF WIRELESS TELECOMMUNICATION DEVICES TO GLOBAL COMMUNICATIONS NETWORKS AND WHICH ENABLES THE TRANSMISSION OF VOICE, DATA AND IMAGES OVER SUCH NETWORKS (U.S. CLS. 21, 23, 26, 36 AND 38).

HENRY S. ZAK, EXAMINING ATTORNEY

SN 85-150,050. LIGHTSPEED TECHNOLOGIES, INC., TUALATIN, OR. FILED 10-11-2010.

**AV DIRECTOR**

THE MARK CONSISTS OF STANDARD CHARACTERS WITHOUT CLAIM TO ANY PARTICULAR FONT, STYLE, SIZE, OR COLOR.

NO CLAIM IS MADE TO THE EXCLUSIVE RIGHT TO USE "AV", APART FROM THE MARK AS SHOWN.

FOR TRANSCIEVERS; WIRELESS CONTROLLER TO CONTROL THE FUNCTION OF OTHER ELECTRONIC DEVICES (U.S. CLS. 21, 23, 26, 36 AND 38).

ELIZABETH KAJUBI, EXAMINING ATTORNEY

**CLASS 9—(Continued).**

SN 85-150,239. FIRED UP CORPORATION LTD, DBA CORBY OF WINDSOR, HUDDERSFIELD, W. YORKS, UNITED KINGDOM, FILED 10-12-2010.



NO CLAIM IS MADE TO THE EXCLUSIVE RIGHT TO USE "WINDSOR", APART FROM THE MARK AS SHOWN. THE COLOR(S) RED, BLACK AND WHITE IS/ARE CLAIMED AS A FEATURE OF THE MARK.

THE MARK CONSISTS OF THE TERM "CORBY" IN WHITE TEXT IN ALTERNATING RED AND BLACK SQUARES ABOVE THE WORDS "OF WINDSOR" IN BLACK TEXT.

SEC. 2(F).  
FOR IRON PRESSING MACHINES (U.S. CLS. 21, 23, 26, 36 AND 38).

FIRST USE 8-18-1972; IN COMMERCE 5-1-2010.  
RONALD MCMORROW, EXAMINING ATTORNEY

SN 85-150,524. PENNWELL CORPORATION, TULSA, OK. FILED 10-12-2010.

**POWER ENGINEERING**

THE MARK CONSISTS OF STANDARD CHARACTERS WITHOUT CLAIM TO ANY PARTICULAR FONT, STYLE, SIZE, OR COLOR.

OWNER OF U.S. REG. NOS. 629,133 AND 1,788,863.  
SEC. 2(F).  
FOR DOWNLOADABLE ELECTRONIC MAGAZINE RELATING TO THE POWER GENERATION INDUSTRY (U.S. CLS. 21, 23, 26, 36 AND 38).  
FIRST USE 1-31-2006; IN COMMERCE 1-31-2006.  
WILLIAM BRECKENFELD, EXAMINING ATTORNEY

SN 85-150,555. COLORWARE INC., WINONA, MN. FILED 10-12-2010.

**COLORWARE GRIP**

THE MARK CONSISTS OF STANDARD CHARACTERS WITHOUT CLAIM TO ANY PARTICULAR FONT, STYLE, SIZE, OR COLOR.

OWNER OF U.S. REG. NOS. 3,114,033 AND 3,726,220.  
NO CLAIM IS MADE TO THE EXCLUSIVE RIGHT TO USE "GRIP", APART FROM THE MARK AS SHOWN.  
FOR PROTECTIVE CARRYING CASES FOR PORTABLE ELECTRONIC DEVICES, NAMELY, PERSONAL DIGITAL ASSISTANTS, SMART PHONES, DIGITAL MUSIC PLAYERS AND PORTABLE COMPUTERS (U.S. CLS. 21, 23, 26, 36 AND 38).  
LESLIE RICHARDS, EXAMINING ATTORNEY

**CLASS 9—(Continued).**

SN 85-151,032. ATLANTIC CITY COIN & SLOT SERVICE COMPANY, INC., PLEASANTVILLE, NJ. FILED 10-12-2010.

**MAX BONUS JACKPOT HERO**

THE MARK CONSISTS OF STANDARD CHARACTERS WITHOUT CLAIM TO ANY PARTICULAR FONT, STYLE, SIZE, OR COLOR.

NO CLAIM IS MADE TO THE EXCLUSIVE RIGHT TO USE "MAX BONUS" AND "JACKPOT", APART FROM THE MARK AS SHOWN.

FOR GAMING MACHINES (U.S. CLS. 21, 23, 26, 36 AND 38).  
TOBY BULLOFF, EXAMINING ATTORNEY

SN 85-151,075. AUBURN AUDIO TECHNOLOGIES, INC., DBA ANTARES AUDIO TECHNOLOGIES, SCOTTS VALLEY, CA. FILED 10-12-2010.

**MIC MOD**

THE MARK CONSISTS OF STANDARD CHARACTERS WITHOUT CLAIM TO ANY PARTICULAR FONT, STYLE, SIZE, OR COLOR.

NO CLAIM IS MADE TO THE EXCLUSIVE RIGHT TO USE "MIC", APART FROM THE MARK AS SHOWN.  
FOR COMPUTER SOFTWARE FOR USE IN MUSIC PRODUCTION; COMPUTER SOFTWARE TO IMPROVE AUDIO EQUIPMENT SOUND QUALITY; COMPUTER SOFTWARE FOR MANIPULATING DIGITAL AUDIO INFORMATION (U.S. CLS. 21, 23, 26, 36 AND 38).  
ANDREA HACK, EXAMINING ATTORNEY

SN 85-151,362. PENNWELL CORPORATION, TULSA, OK. FILED 10-13-2010.

**FIRE ENGINEERING**

THE MARK CONSISTS OF STANDARD CHARACTERS WITHOUT CLAIM TO ANY PARTICULAR FONT, STYLE, SIZE, OR COLOR.

OWNER OF U.S. REG. NO. 641,416.  
SEC. 2(F).  
FOR DOWNLOADABLE ELECTRONIC MAGAZINE RELATING TO FIRE SERVICE (U.S. CLS. 21, 23, 26, 36 AND 38).  
FIRST USE 11-30-2005; IN COMMERCE 11-30-2005.  
WILLIAM BRECKENFELD, EXAMINING ATTORNEY

**CLASS 9—(Continued).**

SN 85-151,568. MEYER SOUND LABORATORIES, INCORPORATED, BERKELEY, CA. FILED 10-13-2010.

**CINEMA EXP**

THE MARK CONSISTS OF STANDARD CHARACTERS WITHOUT CLAIM TO ANY PARTICULAR FONT, STYLE, SIZE, OR COLOR.

NO CLAIM IS MADE TO THE EXCLUSIVE RIGHT TO USE "CINEMA", APART FROM THE MARK AS SHOWN.

FOR LOUDSPEAKERS FOR USE IN MOVIE THEATER SOUND SYSTEMS AND IN POST PRODUCTION STUDIOS FOR MIXING SOUND FOR PICTURES (U.S. CLS. 21, 23, 26, 36 AND 38).

JULIE VEPPUMTHARA, EXAMINING ATTORNEY

---

SN 85-152,152. ACCRETIVE HEALTH, INC., CHICAGO, IL. FILED 10-13-2010.

**UTC**

THE MARK CONSISTS OF STANDARD CHARACTERS WITHOUT CLAIM TO ANY PARTICULAR FONT, STYLE, SIZE, OR COLOR.

FOR COMPUTER SOFTWARE USED TO COMPARE PAYMENTS MADE BY THIRD PARTIES AGAINST CALCULATED EXPECTED PAYMENTS FOR CRITERIA-BASED CLAIM LEVEL VARIANCE ANALYSIS (U.S. CLS. 21, 23, 26, 36 AND 38).

FIRST USE 3-23-2010; IN COMMERCE 3-23-2010.  
STEVEN R. FINE, EXAMINING ATTORNEY

---

SN 85-152,183. YOONO, INC, SAN FRANCISCO, CA. FILED 10-13-2010.

**SOCIALZINE**

THE MARK CONSISTS OF STANDARD CHARACTERS WITHOUT CLAIM TO ANY PARTICULAR FONT, STYLE, SIZE, OR COLOR.

FOR COMPUTER APPLICATION SOFTWARE FOR PCS, MOBILE PHONES, PORTABLE MEDIA PLAYERS, AND HANDHELD COMPUTERS, NAMELY, SOFTWARE FOR CONVERTING ONLINE SOCIAL NETWORK NEWS FEEDS TO A MAGAZINE-STYLE DISPLAY (U.S. CLS. 21, 23, 26, 36 AND 38).

ROBIN CHOSID, EXAMINING ATTORNEY

**CLASS 9—(Continued).**

SN 85-152,237. GRATER, JEREMY L., SEATTLE, WA. FILED 10-14-2010.

**The Sibling Rivalry**

THE MARK CONSISTS OF STANDARD CHARACTERS WITHOUT CLAIM TO ANY PARTICULAR FONT, STYLE, SIZE, OR COLOR.

FOR DOWNLOADABLE MP3 FILES, MP3 RECORDINGS, ON-LINE DISCUSSION BOARDS, WEBCASTS, WEBINARS AND PODCASTS FEATURING MUSIC, AUDIO BOOKS IN THE FIELD OF COMEDY, AND NEWS BROADCASTS; DOWNLOADABLE PODCASTS IN THE FIELD OF COMEDY (U.S. CLS. 21, 23, 26, 36 AND 38).

FIRST USE 8-23-2005; IN COMMERCE 8-23-2005.  
CHRISTOPHER BUONGIORNO, EXAMINING ATTORNEY

---

SN 85-152,491. THE UNITED STATES PLAYING CARD COMPANY, ERLANGER, KY. FILED 10-14-2010.



OWNER OF U.S. REG. NOS. 1,126,822, 2,050,539 AND OTHERS.

NO CLAIM IS MADE TO THE EXCLUSIVE RIGHT TO USE "GAMING", APART FROM THE MARK AS SHOWN.

THE MARK CONSISTS OF THE LITERAL ELEMENT "HOYLE" CENTERED ABOVE THE LITERAL ELEMENT "THE OFFICIAL NAME IN GAMING" WITH A SPADE CHARACTER CENTERED UNDER THE LETTERS "O", "Y", AND "L" IN THE LITERAL "HOYLE" AND "A", "L", "N", "A", "M", "E", "I", AND "N" IN "THE OFFICIAL NAME IN GAMING".

FOR ELECTRONIC GAME PROGRAMS FOR PLAYING CARD, CASINO, PUZZLE AND BOARD GAMES (U.S. CLS. 21, 23, 26, 36 AND 38).

FIRST USE 4-30-2006; IN COMMERCE 4-30-2006.  
JULIE VEPPUMTHARA, EXAMINING ATTORNEY

**CLASS 9—(Continued).**

SN 85-152,981. C. E. ELECTRONICS INC., BRYAN, OH.  
FILED 10-14-2010.

# ELITE PI

THE MARK CONSISTS OF STANDARD CHARACTERS WITHOUT CLAIM TO ANY PARTICULAR FONT, STYLE, SIZE, OR COLOR.

OWNER OF U.S. REG. NO. 2,398,920.

NO CLAIM IS MADE TO THE EXCLUSIVE RIGHT TO USE "PI", APART FROM THE MARK AS SHOWN.

FOR COMPUTER HARDWARE AND ACCOMPANYING PROGRAMMABLE SOFTWARE FOR PROVIDING A VARIETY OF ELEVATOR INDICATOR FUNCTIONS, AND CUSTOM TEXT AND GRAPHIC-BASED MESSAGES (U.S. CLS. 21, 23, 26, 36 AND 38).

FIRST USE 12-31-1996; IN COMMERCE 12-31-1996.

CHERYL CLAYTON, EXAMINING ATTORNEY

SN 85-153,711. SAMSUNG ELECTRONICS CO., LTD.,  
GYEONGGI-DO, REPUBLIC OF KOREA, FILED 10-15-  
2010.



## Readers Hub

OWNER OF U.S. REG. NOS. 2,882,774, 2,929,523 AND OTHERS.

NO CLAIM IS MADE TO THE EXCLUSIVE RIGHT TO USE "READERS HUB", APART FROM THE MARK AS SHOWN.

THE COLOR(S) GRAY, BLUE, GREEN, WHITE, BEIGE AND BLACK IS/ARE CLAIMED AS A FEATURE OF THE MARK.

THE MARK CONSISTS OF THE FOLLOWING: A BOOK/MAGAZINE DESIGN APPEARS FOLDED OPEN WITH WHITE AND GRAY PAGES. A PICTURE OF A BEACH SCENE WITH A CANOE APPEARS IN THE COLORS BLUE, GREEN, BEIGE AND BLACK IN THE MIDDLE OF THE FULL BOOK/MAGAZINE PAGE. THE NUMERAL "2" IN BLACK AND ILLEGIBLE TEXT THAT DOES NOT HAVE ANY MEANING IN BLACK ABOVE THE "2" ALL IN A BEIGE SQUARE ON THE TOP LEFT OF THE FULL BOOK/MAGAZINE PAGE. THE WORD "SAMSUNG" APPEARS IN

**CLASS 9—(Continued).**

GRAY AT THE TOP MIDDLE OF THE FULL BOOK/MAGAZINE PAGE AND ILLEGIBLE TEXT THAT DOES NOT HAVE ANY MEANING IN GRAY APPEARS ABOVE AND BELOW THE BEACH SCENE ON THE FULL BOOK/MAGAZINE PAGE. A BEACH SCENE IN BLUE, GREEN AND BEIGE APPEARS ON THE FOLDED OVER PORTION OF THE BOOK/MAGAZINE WITH GRAY ILLEGIBLE TEXT THAT DOES NOT HAVE ANY MEANING BELOW IT. THE WORDS "READERS HUB" APPEARS IN BLACK BELOW THE BOOK/MAGAZINE DESIGN.

THE ENGLISH TRANSLATION OF THE WORD "SAMSUNG" IN THE MARK IS "THREE STARS".

FOR MOBILE PHONE; SMART PHONE; PORTABLE COMPUTER; TABLET COMPUTER; COMPUTER SOFTWARE FOR MANAGING AND ORGANIZING VARIOUS DIGITAL READING CONTENTS SUCH AS E-BOOK, E-NEWSPAPER, E-MAGAZINE (U.S. CLS. 21, 23, 26, 36 AND 38).

MEGHAN REINHART, EXAMINING ATTORNEY

SN 85-153,714. BONNIER CORPORATION, WINTER PARK,  
FL. FILED 10-15-2010.

## POPULAR PHOTOGRAPHY+

THE MARK CONSISTS OF STANDARD CHARACTERS WITHOUT CLAIM TO ANY PARTICULAR FONT, STYLE, SIZE, OR COLOR.

OWNER OF U.S. REG. NOS. 511,952 AND 1,613,788.

FOR COMPUTER APPLICATION SOFTWARE FOR USE ON MOBILE AND CELLULAR PHONES AND HAND-HELD COMPUTER PLATFORMS FOR ACCESSING, VIEWING, DOWNLOADING, DISTRIBUTING, AND INTERACTING WITH ELECTRONIC PUBLICATIONS SUCH AS MAGAZINES, PERIODICALS, NEWSPAPERS, AND CATALOGS IN A DIGITAL VERSION (U.S. CLS. 21, 23, 26, 36 AND 38).

FIRST USE 5-15-2010; IN COMMERCE 8-30-2010.

LINDA POWELL, EXAMINING ATTORNEY

SN 85-154,321. DUE DILIGENCE INFORMATION ENTERPRISES, LLC, DES MOINES, IA. FILED 10-16-2010.



THE COLOR(S) BLUE, WHITE AND YELLOW IS/ARE CLAIMED AS A FEATURE OF THE MARK.

THE MARK CONSISTS OF THE WORDS "DOCKET IN YOUR POCKET" IN STYLIZED BLUE FONT, WITH THE "O IN POCKET" DEPICTED AS A BLUE PANT POCKET WITH YELLOW STITCHING AND WHITE SCALES ON TOP OF IT.

FOR COMPUTER SOFTWARE FOR COMMUNICATING WITH USERS OF HAND-HELD COMPUTERS; COMPUTER SOFTWARE FOR CREATING SEARCHABLE DATABASES OF INFORMATION AND DATA (U.S. CLS. 21, 23, 26, 36 AND 38).

FIRST USE 10-16-2010; IN COMMERCE 10-16-2010.

FRANK LATTUCA, EXAMINING ATTORNEY

**CLASS 9—(Continued).**

SN 85-154,344. DRE'S DIESEL DOME, LLC, CHICAGO, IL. FILED 10-16-2010.



NO CLAIM IS MADE TO THE EXCLUSIVE RIGHT TO USE "HUSTLE THE ULTIMATE LINE DANCE WORKOUT", APART FROM THE MARK AS SHOWN.

THE MARK CONSISTS OF THE WORDS "DIESEL DOME HUSTLE" IN STYLIZED CAPITAL LETTERS, EXCEPT THE LETTER "T" IS IN LOWER CASE. THE WORD "HUSTLE" IS IN BIGGER FONT. THE TEXT IS WITHIN A RECTANGULAR BOX. IN THE UPPER RIGHT CORNER OF THE RECTANGULAR BOX ARE FIVE ROUND MUSIC SPEAKERS OF VARIOUS SIZES. DIRECTLY ABOVE THE MUSIC SPEAKERS AND OUTSIDE THE RECTANGULAR BOX ARE SILHOUETTES OF MALES AND FEMALES DANCING OR WORKING OUT. DIRECTLY BELOW THE RECTANGULAR BOX IS THE STYLIZED WORDS "THE ULTIMATE LINE DANCE WORKOUT" WHICH ARE IN A SMALLER FONT SIZE. THE BACKGROUND OUTSIDE THE RECTANGULAR BOX CONSISTS OF SWIRL/CURVED LINES AND CURVED LINES WITH SHADOWS.

FOR DVD FEATURING EXERCISE AND FITNESS TRAINING (U.S. CLS. 21, 23, 26, 36 AND 38).

ANDREA HACK, EXAMINING ATTORNEY

SN 85-154,592. 1G COMPUTING LLC, SAN DIEGO, CA. FILED 10-18-2010.

**JUNIOR SHIELD**

THE MARK CONSISTS OF STANDARD CHARACTERS WITHOUT CLAIM TO ANY PARTICULAR FONT, STYLE, SIZE, OR COLOR.

NO CLAIM IS MADE TO THE EXCLUSIVE RIGHT TO USE "JUNIOR", APART FROM THE MARK AS SHOWN.

FOR COMPUTER SOFTWARE FOR PROTECTION OF CHILDREN WHEN USING A COMPUTER AND THE PREVENTION OF CORRUPTION TO ALREADY INSTALLED SOFTWARE ON COMPUTER HARDWARE (U.S. CLS. 21, 23, 26, 36 AND 38).

BENJAMIN OKEKE, EXAMINING ATTORNEY

**CLASS 9—(Continued).**

SN 85-154,859. FUTUREVIDEO PRODUCTS, INC, LAGUNA NIGUEL, CA. FILED 10-18-2010.

**MEDIA COMMANDER**

THE MARK CONSISTS OF STANDARD CHARACTERS WITHOUT CLAIM TO ANY PARTICULAR FONT, STYLE, SIZE, OR COLOR.

NO CLAIM IS MADE TO THE EXCLUSIVE RIGHT TO USE "MEDIA", APART FROM THE MARK AS SHOWN. FOR ELECTRICAL CONTROLLERS (U.S. CLS. 21, 23, 26, 36 AND 38).

FIRST USE 2-2-1995; IN COMMERCE 3-14-1996.

CHARLES L. JENKINS, EXAMINING ATTORNEY

SN 85-155,554. ELITE DISPLAY PRODUCTS LLC, AKA ELITE DISPLAY USA, KENILWORTH, NJ. FILED 10-18-2010.

**Digital Brand Ambassador**

THE MARK CONSISTS OF STANDARD CHARACTERS WITHOUT CLAIM TO ANY PARTICULAR FONT, STYLE, SIZE, OR COLOR.

NO CLAIM IS MADE TO THE EXCLUSIVE RIGHT TO USE "DIGITAL BRAND", APART FROM THE MARK AS SHOWN.

FOR ELECTRONIC DISPLAYS, NAMELY, DIGITAL SIGNAGE IN THE NATURE OF AN ELECTRONIC DIGITAL DEVICE USED FOR ADVERTISING, MARKETING, PROMOTIONAL SERVICES AND PROVIDING INFORMATION USING AUDIO, VIDEO AND TEXT (U.S. CLS. 21, 23, 26, 36 AND 38).

FIRST USE 8-10-2008; IN COMMERCE 9-2-2009.

JAMES STEIN, EXAMINING ATTORNEY

SN 85-155,910. NCOVER LLC, GREENVILLE, SC. FILED 10-19-2010.

**Code Central**

THE MARK CONSISTS OF STANDARD CHARACTERS WITHOUT CLAIM TO ANY PARTICULAR FONT, STYLE, SIZE, OR COLOR.

NO CLAIM IS MADE TO THE EXCLUSIVE RIGHT TO USE "CODE", APART FROM THE MARK AS SHOWN.

FOR COMPUTER SOFTWARE DEVELOPMENT TOOLS (U.S. CLS. 21, 23, 26, 36 AND 38).

ANNE MADDEN, EXAMINING ATTORNEY

**CLASS 9—(Continued).**

SN 85-156,518. SIERRA ATLANTIC, INC., NEWARK, CA.  
FILED 10-19-2010.

**SEAMLESS STP**

THE MARK CONSISTS OF STANDARD CHARACTERS WITHOUT CLAIM TO ANY PARTICULAR FONT, STYLE, SIZE, OR COLOR.

NO CLAIM IS MADE TO THE EXCLUSIVE RIGHT TO USE "STP", APART FROM THE MARK AS SHOWN.

FOR COMPUTER SOFTWARE THAT AUTOMATES PAYABLES, BANK ACCOUNT RECONCILIATIONS, TRADE FINANCING AND OTHER TREASURY MANAGEMENT FUNCTIONS FOR AN END TO END TRANSACTION PROCESSING SOLUTION (U.S. CLS. 21, 23, 26, 36 AND 38).

EMILY CHUO, EXAMINING ATTORNEY

SN 85-156,528. HUANG-YU LIN, VALLEY STREAM, NY.  
FILED 10-19-2010.

**IVIO**

OWNER OF U.S. REG. NO. 3,720,634.  
THE MARK CONSISTS OF THE LETTERS "IVIO", WITH AN ENLARGED MODIFIED "V".

FOR BUILDING SECURITY SYSTEMS COMPRISING SOFTWARE AND HARDWARE FOR PROVIDING PICTURE, VIDEO, ALARM STATUS, BUILDING PLANS, AND OTHER INFORMATION TO A REMOTE STATION; CARRYING CASES FOR CELL PHONES; CELL PHONE BACKPLATES; CELL PHONE BATTERY CHARGERS; CELL PHONE BATTERY CHARGERS FOR USE IN VEHICLES; CELL PHONE CASES; CELL PHONE COVERS; CELL PHONE FACEPLATES; CELL PHONES; CELLULAR PHONE ACCESSORY CHARMS; CELLULAR PHONES; CLOSED CIRCUIT TV SYSTEMS FOR SECURITY AND SURVEILLANCE, NAMELY, CAMERAS, SWITCHERS, MONITORS, MICROPHONES, AND RECORDERS; COMPUTER EQUIPMENT, NAMELY, WIRELESS CARDS; COMPUTER FAX MODEM CARDS; COMPUTER HARDWARE, NAMELY, WIRELESS ACCESS POINT (WAP) DEVICES; COMPUTERIZED VIDEO TABLE GAMES FOR GAMING PURPOSES; ELECTRONIC AND ELECTRO-MECHANICAL GAMING TABLES WITH VIDEO OUTPUT; ELECTRONIC VIDEO SURVEILLANCE PRODUCTS, NAMELY, ELECTRONIC COMPO-

**CLASS 9—(Continued).**

NENTS OF SECURITY SYSTEMS; EXTERNAL MODEMS; INTERNAL MODEMS; LCD MONITORS FOR SECURITY PURPOSES; LIQUID CRYSTAL DISPLAY (LCD) TELEVISIONS; MEDIA PLAYERS; MODEMS; PC TABLET; PERSONAL SECURITY ALARMS; PORTABLE MEDIA PLAYERS; PORTABLE TELEVISIONS; PROTECTIVE COVERS AND CASES FOR CELL PHONES, LAPTOPS AND PORTABLE MEDIA PLAYERS; SECURITY ALARM CONTROLLERS; SECURITY AND FIRE ALARMS; SECURITY CONTROL PANELS AND MOTION DETECTORS; TELEVISION MONITORS; TELEVISION SETS; VIDEO AND COMPUTER GAME PROGRAMS; VIDEO GAME INTERACTIVE HAND HELD REMOTE CONTROLS FOR PLAYING ELECTRONIC GAMES; VIDEO GAME MACHINES FOR USE WITH EXTERNAL DISPLAY SCREEN OR MONITOR; WIRELESS COMMUNICATION DEVICES FOR VOICE, DATA OR IMAGE TRANSMISSION; WIRELESS TELEVISION SET FOR PROVIDING VIDEO CONFERENCING AND TELEPHONE SERVICE OVER THE INTERNET (U.S. CLS. 21, 23, 26, 36 AND 38).

EMILY CHUO, EXAMINING ATTORNEY

SN 85-156,602. NARIO, ANTHONY, INGLEWOOD, CA.  
FILED 10-20-2010.

**hiphopalkatraz**

THE MARK CONSISTS OF STANDARD CHARACTERS WITHOUT CLAIM TO ANY PARTICULAR FONT, STYLE, SIZE, OR COLOR.

FOR SOUND RECORDINGS FEATURING MUSIC (U.S. CLS. 21, 23, 26, 36 AND 38).

FIRST USE 9-1-2009; IN COMMERCE 9-1-2009.

LAURIE KAUFMAN, EXAMINING ATTORNEY

SN 85-156,944. MITUTOYO CORPORATION, KAWASAKI, KANAGAWA, JAPAN, FILED 10-20-2010.

**QUICK VISION WLI**

THE MARK CONSISTS OF STANDARD CHARACTERS WITHOUT CLAIM TO ANY PARTICULAR FONT, STYLE, SIZE, OR COLOR.

OWNER OF U.S. REG. NO. 1,945,824.

NO CLAIM IS MADE TO THE EXCLUSIVE RIGHT TO USE "WLI", APART FROM THE MARK AS SHOWN.

FOR COORDINATE MEASURING MACHINES; COORDINATE MEASURING MACHINES FOR USE IN MEASURING DIMENSIONS OF VARIOUS MACHINE PARTS AND ASSEMBLIES IN THREE DIMENSIONS; COMPUTER HARDWARE AND NON-CONTACT COORDINATE MEASURING MACHINES FOR LOCATING, IDENTIFYING, MEASURING AND INSPECTING OBJECTS, AND COMPUTER OPERATING PROGRAMS FOR USE THEREWITH (U.S. CLS. 21, 23, 26, 36 AND 38).

HANNO RITTNER, EXAMINING ATTORNEY

**CLASS 9—(Continued).**

SN 85-156,967. CANFIELD SCIENTIFIC, INC., FAIRFIELD, NJ. FILED 10-20-2010.

# DermScope

THE MARK CONSISTS OF STANDARD CHARACTERS WITHOUT CLAIM TO ANY PARTICULAR FONT, STYLE, SIZE, OR COLOR.

FOR IMAGING DEVICE CONSISTING ESSENTIALLY OF A CAMERA LENS, LIGHTING APPARATUS, AND COMPUTER SOFTWARE; COMPUTER SOFTWARE FOR USE IN DIGITAL IMAGE CAPTURE, IMAGE PROCESSING, QUANTITATIVE ANALYSIS, DISPLAY, AND COMPARISON, ALL FOR USE IN THE FIELDS OF DERMATOLOGY, OTHER FIELDS OF MEDICINE, AND COSMETOLOGY/BEAUTY CARE; COMPUTER SOFTWARE FOR USE IN DIGITAL IMAGE CAPTURE, IMAGE PROCESSING, AND, QUANTITATIVE ANALYSIS, DISPLAY, AND COMPARISON OF THE CAPTURED IMAGES, FOR GENERAL USE (U.S. CLS. 21, 23, 26, 36 AND 38).

HANNO RITTNER, EXAMINING ATTORNEY

SN 85-157,888. SINGH, RAJPAL, SOUTH FLORAL PARK, NY. FILED 10-21-2010.

# bollywoodprince

THE MARK CONSISTS OF STANDARD CHARACTERS WITHOUT CLAIM TO ANY PARTICULAR FONT, STYLE, SIZE, OR COLOR.

FOR SOUND RECORDINGS FEATURING MUSIC (U.S. CLS. 21, 23, 26, 36 AND 38).

LOURDES AYALA, EXAMINING ATTORNEY

SN 85-157,900. STARLUCK LLC, LAS VEGAS, NV. FILED 10-21-2010.

# FACE PROTECTION FOR THE HARDCORE ENTHUSIAST

THE MARK CONSISTS OF STANDARD CHARACTERS WITHOUT CLAIM TO ANY PARTICULAR FONT, STYLE, SIZE, OR COLOR.

NO CLAIM IS MADE TO THE EXCLUSIVE RIGHT TO USE "FACE PROTECTION", APART FROM THE MARK AS SHOWN.

FOR DUST MASKS; DUST PROTECTIVE GOGGLES AND MASKS; PROTECTION MASKS; PROTECTIVE FACE MASKS NOT FOR MEDICAL PURPOSES; RESPIRATORY MASK FILTERS; PROTECTIVE FACE MASKS FOR GENERAL USE BY MOTORCYCLISTS, NOT FOR MEDICAL OR SPORTS PURPOSES (U.S. CLS. 21, 23, 26, 36 AND 38).

CHRISTINA SOBRAL, EXAMINING ATTORNEY

**CLASS 9—(Continued).**

SN 85-158,152. TERENCE W. JUNG, FLUSHING, NY. FILED 10-21-2010.



THE MARK CONSISTS OF THE HIGHLY STYLIZED LETTERS "VXNX" ALL CONTAINED WITHIN A DARKENED RECTANGLE.

FOR ELECTROACOUSTIC APPARATUS, NAMELY, LOUDSPEAKERS, AMPLIFIERS, ELECTROACOUSTIC TRANSDUCERS, HEADPHONES, MICROPHONES AND STRUCTURAL PARTS THEREFOR (U.S. CLS. 21, 23, 26, 36 AND 38).

FIRST USE 10-7-2009; IN COMMERCE 10-7-2009.

LINDA E. BLOHM, EXAMINING ATTORNEY

SN 85-158,518. SHUFFLE MASTER AUSTRALASIA PTY LIMITED, MILPERRA NSW, AUSTRALIA, FILED 10-21-2010.



THE MARK CONSISTS OF A JESTER'S HAT.

FOR HARDWARE AND SOFTWARE FOR INCORPORATING A BONUS FEATURE IN A GAMING MACHINE WITH OR WITHOUT VIDEO OUTPUT, HARDWARE AND SOFTWARE FOR PROVIDING A BONUSING SYSTEM FOR LINKED GAMING MACHINES (U.S. CLS. 21, 23, 26, 36 AND 38).

BRIAN CALLAGHAN, EXAMINING ATTORNEY

**CLASS 9—(Continued).**

SN 85-158,693. ASICSERVE LTD., MODIIN, ISRAEL, FILED 10-22-2010.

# ETS2XL

THE MARK CONSISTS OF STANDARD CHARACTERS WITHOUT CLAIM TO ANY PARTICULAR FONT, STYLE, SIZE, OR COLOR.

OWNER OF U.S. REG. NO. 3,779,231.  
FOR COMPUTER SOFTWARE FOR USE IN DESIGNING SILICON CHIPS (U.S. CLS. 21, 23, 26, 36 AND 38).  
DAVID I, EXAMINING ATTORNEY

**CLASS 9—(Continued).**

SN 85-158,700. ASICSERVE LTD., MODIIN, ISRAEL, FILED 10-22-2010.

# STA2XL

THE MARK CONSISTS OF STANDARD CHARACTERS WITHOUT CLAIM TO ANY PARTICULAR FONT, STYLE, SIZE, OR COLOR.

OWNER OF U.S. REG. NO. 3,779,231.  
FOR COMPUTER SOFTWARE FOR USE IN DESIGNING SILICONE CHIPS (U.S. CLS. 21, 23, 26, 36 AND 38).  
DAVID I, EXAMINING ATTORNEY

SN 85-158,695. ASICSERVE LTD., MODIIN, ISRAEL, FILED 10-22-2010.

# GT2XL

THE MARK CONSISTS OF STANDARD CHARACTERS WITHOUT CLAIM TO ANY PARTICULAR FONT, STYLE, SIZE, OR COLOR.

OWNER OF U.S. REG. NO. 3,779,231.  
FOR COMPUTER SOFTWARE AND HARDWARE FOR USE IN DESIGNING SILICON CHIPS (U.S. CLS. 21, 23, 26, 36 AND 38).  
DAVID I, EXAMINING ATTORNEY

SN 85-158,703. ASICSERVE LTD., MODIIN, ISRAEL, FILED 10-22-2010.

# ASIC2XL

THE MARK CONSISTS OF STANDARD CHARACTERS WITHOUT CLAIM TO ANY PARTICULAR FONT, STYLE, SIZE, OR COLOR.

OWNER OF U.S. REG. NO. 3,779,231.  
FOR COMPUTER SOFTWARE FOR USE IN DESIGNING SILICONE CHIPS (U.S. CLS. 21, 23, 26, 36 AND 38).  
DAVID I, EXAMINING ATTORNEY

SN 85-158,698. ASICSERVE LTD., MODIIN, ISRAEL, FILED 10-22-2010.

# TKTN2XL

THE MARK CONSISTS OF STANDARD CHARACTERS WITHOUT CLAIM TO ANY PARTICULAR FONT, STYLE, SIZE, OR COLOR.

OWNER OF U.S. REG. NO. 3,779,231.  
FOR COMPUTER SOFTWARE FOR USE IN DESIGNING SILICON COMPUTER CHIPS (U.S. CLS. 21, 23, 26, 36 AND 38).  
DAVID I, EXAMINING ATTORNEY

SN 85-158,846. TAVE CORPORATION, TAMARAC, FL. FILED 10-22-2010.

# Táve

THE MARK CONSISTS OF THE TERM "TAVE" WITH AN ACCENT ON THE "A".

THE WORDING "TAVE" HAS NO MEANING IN A FOREIGN LANGUAGE.

FOR DOWNLOADABLE COMPUTER SOFTWARE FOR OFFICE MANAGEMENT, NAMELY, SOFTWARE FOR MANAGING A PHOTOGRAPHIC STUDIO OR BUSINESS (U.S. CLS. 21, 23, 26, 36 AND 38).

FIRST USE 8-10-2007; IN COMMERCE 8-10-2007.  
TEJBIR SINGH, EXAMINING ATTORNEY



**CLASS 9—(Continued).**

SN 85-158,871. BIALECKI, GEORGE, WARRENVILLE, IL. FILED 10-22-2010.

# HELP

THE MARK CONSISTS OF STANDARD CHARACTERS WITHOUT CLAIM TO ANY PARTICULAR FONT, STYLE, SIZE, OR COLOR.

FOR ELECTRONIC SYSTEM COMPRISED OF A TRANSMITTER AND PROGRAMMABLE RECEIVING DISPLAY UNIT USED FOR MEASURING AND DISPLAYING ELECTRICAL POWER AND WATER CONSUMPTION (U.S. CLS. 21, 23, 26, 36 AND 38).

YAT SYE, LEE, EXAMINING ATTORNEY

SN 85-159,487. LEAP FORWARD GAMING, RENO, NV. FILED 10-22-2010.

# PlayPal

THE MARK CONSISTS OF STANDARD CHARACTERS WITHOUT CLAIM TO ANY PARTICULAR FONT, STYLE, SIZE, OR COLOR.

FOR COMPONENTS FOR GAMING MACHINES THAT GENERATE OR DISPLAY WAGER OUTCOMES, NAMELY, CONTROLLERS, DISPLAYS, BUTTON PANELS, BOLSTERS, ELECTRICAL WIRING, AND COMPUTER HARDWARE AND SOFTWARE ASSOCIATED THEREWITH; COMPUTER GAME SOFTWARE FOR GAMING MACHINES INCLUDING SLOT MACHINES OR VIDEO LOTTERY TERMINALS; COMPUTER SOFTWARE AND FIRMWARE FOR GAMES OF CHANCE ON ANY COMPUTERIZED PLATFORM, INCLUDING DEDICATED GAMING CONSOLES, VIDEO BASED SLOT MACHINES, REEL BASED SLOT MACHINES, AND VIDEO LOTTERY TERMINALS; ELECTRONIC GAMING MACHINES, NAMELY, DEVICES WHICH ACCEPT A WAGER; GAMING DEVICES, NAMELY, GAMING MACHINES, SLOT MACHINES, BINGO MACHINES, WITH OR WITHOUT VIDEO OUTPUT; GAMING MACHINES FEATURING A DEVICE THAT ACCEPTS WAGERS; GAMING MACHINES INCLUDING SLOT MACHINES OR VIDEO LOTTERY TERMINALS; GAMING MACHINES THAT GENERATE OR DISPLAY WAGER OUTCOMES; GAMING MACHINES, NAMELY, DEVICES WHICH ACCEPT A WAGER; GAMING SOFTWARE THAT GENERATES OR DISPLAYS WAGER OUTCOMES OF GAMING MACHINES; RECONFIGURABLE CASINO AND LOTTERY GAMING EQUIPMENT, NAMELY, GAMING MACHINES AND OPERATIONAL COMPUTER GAME SOFTWARE THEREFOR (U.S. CLS. 21, 23, 26, 36 AND 38).

JAMES GRIFFIN, EXAMINING ATTORNEY

**CLASS 9—(Continued).**

SN 85-159,634. STEVENS, FRANK K., DBA BARTAG SOLUTIONS, TERRY, MS. FILED 10-23-2010.

# Bartag

THE MARK CONSISTS OF STANDARD CHARACTERS WITHOUT CLAIM TO ANY PARTICULAR FONT, STYLE, SIZE, OR COLOR.

SEC. 2(F) AS TO BARTAG.

FOR COMPUTER APPLICATION SOFTWARE FOR MOBILE PHONES, NAMELY, SOFTWARE FOR INVENTORY AND BARCODE TRACKING; COMPUTER APPLICATION SOFTWARE FOR WORKSTATIONS, SERVERS, AND MOBILE DEVICES, NAMELY, SOFTWARE FOR INVENTORY AND BARCODE TRACKING; COMPUTER SOFTWARE FOR THE COLLECTION, EDITING, ORGANIZING, MODIFYING, BOOK MARKING, TRANSMISSION, STORAGE AND SHARING OF DATA AND INFORMATION (U.S. CLS. 21, 23, 26, 36 AND 38).

FIRST USE 12-4-2001; IN COMMERCE 12-4-2001.

DORITT L. CARROLL, EXAMINING ATTORNEY

SN 85-159,887. AIRWAY LIMITED, AUCKLAND, NEW ZEALAND, FILED 10-24-2010.

# orsim

THE MARK CONSISTS OF STANDARD CHARACTERS WITHOUT CLAIM TO ANY PARTICULAR FONT, STYLE, SIZE, OR COLOR.

PRIORITY CLAIMED UNDER SEC. 44(D) ON NEW ZEALAND APPLICATION NO. 823424, FILED 4-29-2010, REG. NO. 823424, DATED 4-29-2010, EXPIRES 4-29-2017.

FOR COMPUTER SOFTWARE AND DOWNLOADABLE SOFTWARE, NAMELY, VIRTUAL REALITY SOFTWARE FOR MEDICAL TEACHING; COMPUTER SOFTWARE FOR DATA COLLECTION, PERFORMANCE EVALUATION AND FEEDBACK, AND FOR TEACHING RELATING TO MEDICAL MATTERS; MEDICAL SIMULATORS COMPRISED OF SOFTWARE AND HARDWARE FOR USE AS TEACHING AIDS; MEDICAL SIMULATORS COMPRISED OF SOFTWARE AND HARDWARE FOR TEACHING PROCEDURAL SKILLS (U.S. CLS. 21, 23, 26, 36 AND 38).

JOHN HWANG, EXAMINING ATTORNEY

SN 85-160,174. VILLALOBOS, JUSTO, DALY CITY, CA. FILED 10-25-2010.

# VILLAGE-OF-THE-WOLVES

THE MARK CONSISTS OF STANDARD CHARACTERS WITHOUT CLAIM TO ANY PARTICULAR FONT, STYLE, SIZE, OR COLOR.

FOR DIGITAL MEDIA, NAMELY, DVDS FEATURING MUSIC; DIGITAL MUSIC DOWNLOADABLE FROM THE INTERNET (U.S. CLS. 21, 23, 26, 36 AND 38).

EDWARD NELSON, EXAMINING ATTORNEY

**CLASS 9—(Continued).**

SN 85-160,433. BEYOND VISION, INC., MIAMI, FL. FILED 10-25-2010.

p.o.m.y

THE MARK CONSISTS OF STANDARD CHARACTERS WITHOUT CLAIM TO ANY PARTICULAR FONT, STYLE, SIZE, OR COLOR.

FOR EYEWEAR FOR WHOLESALE DISTRIBUTION (U.S. CLS. 21, 23, 26, 36 AND 38).

FIRST USE 7-28-2010; IN COMMERCE 7-28-2010.  
BARBARA GAYNOR, EXAMINING ATTORNEY

SN 85-160,687. HALL, RICHARD A., NASHVILLE, TN. AND SAETVEIT, JASON K., NASHVILLE, TN. AND EAST, JEFFREY J., NASHVILLE, TN. FILED 10-25-2010.

Bedbug Records

THE MARK CONSISTS OF STANDARD CHARACTERS WITHOUT CLAIM TO ANY PARTICULAR FONT, STYLE, SIZE, OR COLOR.

NO CLAIM IS MADE TO THE EXCLUSIVE RIGHT TO USE "RECORDS", APART FROM THE MARK AS SHOWN.

FOR AUDIO AND VIDEO RECORDINGS FEATURING MUSIC AND ARTISTIC PERFORMANCES (U.S. CLS. 21, 23, 26, 36 AND 38).

FIRST USE 9-17-2010; IN COMMERCE 9-17-2010.  
GISELLE AGOSTO, EXAMINING ATTORNEY

SN 85-160,752. BRILLIANT BASE, LOS ANGELES, CA. FILED 10-25-2010.

brilliantretail

THE MARK CONSISTS OF A SHADED CIRCLE WITH STYLIZED LETTERS "BR" WITH THE STYLIZED TEXT "BRILLIANTRETAIL".

FOR DOWNLOADABLE COMPUTER SOFTWARE FOR USE IN ALLOWING USERS TO BUILD AND CREATE THEIR OWN E-COMMERCE STORE (U.S. CLS. 21, 23, 26, 36 AND 38).

MELISSA VALLILLO, EXAMINING ATTORNEY

**CLASS 9—(Continued).**

SN 85-160,886. HOWE, JAYNEE, SAN FRANCISCO, CA. FILED 10-26-2010.

Geo Tots

THE MARK CONSISTS OF STANDARD CHARACTERS WITHOUT CLAIM TO ANY PARTICULAR FONT, STYLE, SIZE, OR COLOR.

FOR COMPUTER GAME SOFTWARE FOR USE ON MOBILE AND CELLULAR PHONES (U.S. CLS. 21, 23, 26, 36 AND 38).

MATTHEW EINSTEIN, EXAMINING ATTORNEY

SN 85-161,564. ELECTION ADMINISTRATORS, LLC, SAINT LOUIS, MO. FILED 10-26-2010.



election administrators

NO CLAIM IS MADE TO THE EXCLUSIVE RIGHT TO USE "ELECTION ADMINISTRATORS", APART FROM THE MARK AS SHOWN.

THE COLOR(S) RED AND BLUE IS/ARE CLAIMED AS A FEATURE OF THE MARK.

THE MARK CONSISTS OF A STYLIZED "EA" IN BLUE WITH A RED STAR IN THE MIDDLE OF THE A. THE LETTERS BELOW "EA" ARE IN THE SAME RED COLOR AS THE STAR SPELLING "ELECTION ADMINISTRATORS" IN LOWER CASE LETTERS. THE WHITE IS FOR BACKGROUND ONLY AND IS NOT CLAIMED AS A FEATURE OF THE MARK.

FOR COMPUTER APPLICATION SOFTWARE FOR MOBILE PHONES, NAMELY, SOFTWARE FOR LOCAL, STATE, AND FEDERAL GOVERNMENTS FOR USE AS AN ELECTRONIC POLL BOOK TO CHECK VOTERS IN AT THE POLLING PLACE AS WELL AS FOR ADMINISTERING ELECTIONS (U.S. CLS. 21, 23, 26, 36 AND 38).

FIRST USE 9-28-2004; IN COMMERCE 1-1-2005.  
JAMES GRIFFIN, EXAMINING ATTORNEY

SN 85-162,472. IN YOUR FACE LLC, ST GEORGE, UT. FILED 10-27-2010.

carbace

THE MARK CONSISTS OF STANDARD CHARACTERS WITHOUT CLAIM TO ANY PARTICULAR FONT, STYLE, SIZE, OR COLOR.

FOR DEVICES FOR HANDS-FREE USE OF MOBILE PHONES; HANDS FREE KITS FOR PHONES (U.S. CLS. 21, 23, 26, 36 AND 38).

FIRST USE 10-25-2010; IN COMMERCE 10-26-2010.  
HELENE LIWINSKI, EXAMINING ATTORNEY

**CLASS 9—(Continued).**

SN 85-162,850. INTERNATIONAL GAMING PROJECTS LIMITED, VALLETTA, MALTA, FILED 10-27-2010.



THE COLOR(S) GREEN, YELLOW AND BLACK IS/ARE CLAIMED AS A FEATURE OF THE MARK.

THE MARK CONSISTS OF THE WORDING "NEW TRIPLE" DEPICTED IN AN ARC IN THE COLOR GREEN AND OUTLINED IN BLACK AND YELLOW.

FOR VIDEO-GAME MACHINES FOR USE WITH EXTERNAL DISPLAY SCREEN OR MONITOR, AND REPLACEMENT PARTS FOR USE WITH THE MACHINES, NAMELY, POWER CABLES, INTERACTIVE REMOTE CONTROL UNITS AND MEMORY CARDS; COMPUTER GAME PROGRAMS; ELECTRONIC COMPONENTS FOR SLOT MACHINES; AUTOMATIC SLOT MACHINES; AUTOMATIC GAME MACHINES AND GAMING MACHINES, NAMELY, ELECTRONIC SLOT AND BINGO MACHINES (U.S. CLS. 21, 23, 26, 36 AND 38).

KELLY CHOE, EXAMINING ATTORNEY

SN 85-162,853. INTERNATIONAL GAMING PROJECTS LIMITED, VALLETTA, MALTA, FILED 10-27-2010.



THE COLOR(S) ORANGE, LIGHT ORANGE, GREY, YELLOW, WHITE, BLUE AND RED IS/ARE CLAIMED AS A FEATURE OF THE MARK.

THE MARK CONSISTS OF AN ORANGE FISH WITH GREY STRIPES, LIGHT ORANGE FINS AND TAIL AND WITH BLUE AND WHITE EYES ABOVE THE WORDS "EL PEZ" IN YELLOW LETTERS OUTLINED IN RED.

THE ENGLISH TRANSLATION OF "EL PEZ" IN THE MARK IS "FISH".

FOR VIDEO-GAME MACHINES FOR USE WITH EXTERNAL DISPLAY SCREEN OR MONITOR, AND REPLACEMENT PARTS FOR USE WITH THE MACHINES, NAMELY, POWER CABLES, INTERACTIVE REMOTE CONTROL UNITS AND MEMORY CARDS; COMPUTER GAME PROGRAMS; ELECTRONIC COMPONENTS FOR SLOT MACHINES; AUTOMATIC SLOT MACHINES; AUTOMATIC GAME MACHINES AND GAMING MACHINES, NAMELY, ELECTRONIC SLOT AND BINGO MACHINES (U.S. CLS. 21, 23, 26, 36 AND 38).

KELLY CHOE, EXAMINING ATTORNEY

**CLASS 9—(Continued).**

SN 85-166,668. ZILOG, INC., MILPITAS, CA. FILED 11-1-2010.

## mini-Z

THE MARK CONSISTS OF STANDARD CHARACTERS WITHOUT CLAIM TO ANY PARTICULAR FONT, STYLE, SIZE, OR COLOR.

FOR SMALL STAMP-SIZED ELECTRONIC MODULES, NAMELY, MICROCONTROLLERS THAT ARE SPECIALIZED FOR RF WIRELESS APPLICATIONS, ETHERNET HARD-WIRED APPLICATIONS, SINGLE-BOARD MOTOR-CONTROL APPLICATIONS, LIGHTING APPLICATIONS, MOTION DETECTION APPLICATIONS, AND SOLAR ENERGY APPLICATIONS; SOFTWARE THAT RUNS ON MICROCONTROLLER PLATFORMS FOR CONTROLLING ELECTRIC MOTORS, LIGHTING, SECURITY SYSTEMS AND SOLAR ENERGY SYSTEMS (U.S. CLS. 21, 23, 26, 36 AND 38).

GEOFFREY FOSDICK, EXAMINING ATTORNEY

SN 85-166,680. ZILOG, INC., MILPITAS, CA. FILED 11-1-2010.

## micro-Z

THE MARK CONSISTS OF STANDARD CHARACTERS WITHOUT CLAIM TO ANY PARTICULAR FONT, STYLE, SIZE, OR COLOR.

FOR SMALL STAMP-SIZED ELECTRONIC MODULES, NAMELY, MICROCONTROLLERS THAT ARE SPECIALIZED FOR RF WIRELESS APPLICATIONS, ETHERNET HARD-WIRED APPLICATIONS, SINGLE-BOARD MOTOR-CONTROL APPLICATIONS, LIGHTING APPLICATIONS, MOTION DETECTION APPLICATIONS, AND SOLAR ENERGY APPLICATIONS; SOFTWARE THAT RUNS ON MICROCONTROLLER PLATFORMS FOR CONTROLLING ELECTRIC MOTORS, LIGHTING, SECURITY SYSTEMS AND SOLAR ENERGY SYSTEMS (U.S. CLS. 21, 23, 26, 36 AND 38).

GEOFFREY FOSDICK, EXAMINING ATTORNEY

SN 85-167,671. RIPTANO INCORPORATED, AUSTIN, TX. FILED 11-3-2010.

## RIPCORD

THE MARK CONSISTS OF STANDARD CHARACTERS WITHOUT CLAIM TO ANY PARTICULAR FONT, STYLE, SIZE, OR COLOR.

FOR OPERATIONAL SOFTWARE FOR USE IN CONNECTION WITH AN OPEN-SOURCE DATABASE (U.S. CLS. 21, 23, 26, 36 AND 38).

BRIAN NEVILLE, EXAMINING ATTORNEY

**CLASS 9—(Continued).**

SN 85-169,231. JET CITY LASER, INC., AUBURN, WA.  
FILED 11-4-2010.

**BLUE DOG TRACKER**

THE MARK CONSISTS OF STANDARD CHARACTERS WITHOUT CLAIM TO ANY PARTICULAR FONT, STYLE, SIZE, OR COLOR.

NO CLAIM IS MADE TO THE EXCLUSIVE RIGHT TO USE "TRACKER", APART FROM THE MARK AS SHOWN. FOR DOWNLOADABLE SOFTWARE FOR DATA COLLECTION FOR INVENTORY MANAGEMENT (U.S. CLS. 21, 23, 26, 36 AND 38).

EDWARD NELSON, EXAMINING ATTORNEY

---

SN 85-170,021. CORE MOBILE NETWORKS, INC., SANTA CLARA, CA. FILED 11-5-2010.

**UNTETHER THE BUSINESS**

THE MARK CONSISTS OF STANDARD CHARACTERS WITHOUT CLAIM TO ANY PARTICULAR FONT, STYLE, SIZE, OR COLOR.

FOR BROADBAND WIRELESS EQUIPMENT, NAMELY, TELECOMMUNICATIONS BASE STATION EQUIPMENT FOR CELLULAR AND FIXED NETWORKING AND COMMUNICATIONS APPLICATIONS (U.S. CLS. 21, 23, 26, 36 AND 38).

GILBERT SWIFT, EXAMINING ATTORNEY

---

SN 85-170,459. MARK V SYSTEMS LIMITED, ENCINO, CA.  
FILED S.R. 11-5-2010; AM. P.R. 2-23-2011.

**Arelle**

THE MARK CONSISTS OF STANDARD CHARACTERS WITHOUT CLAIM TO ANY PARTICULAR FONT, STYLE, SIZE, OR COLOR.

FOR COMPUTER SOFTWARE FOR THE COLLECTION, EDITING, ORGANIZING, MODIFYING, BOOK MARKING, TRANSMISSION, STORAGE AND SHARING OF DATA AND INFORMATION (U.S. CLS. 21, 23, 26, 36 AND 38).

FIRST USE 11-5-2010; IN COMMERCE 11-5-2010.  
ROBERT STRUCK, EXAMINING ATTORNEY

**CLASS 9—(Continued).**

SN 85-171,049. E-IMAGEDATA CORP., HARTFORD, WI.  
FILED 11-7-2010.

**AUTO-SCAN**

THE MARK CONSISTS OF STANDARD CHARACTERS WITHOUT CLAIM TO ANY PARTICULAR FONT, STYLE, SIZE, OR COLOR.

FOR COMPUTER SOFTWARE FOR CONTROLLING A MICROFILM TRANSPORT AND CAPTURE APPARATUS FOR THE DIGITAL CAPTURE OF IMAGES ON MICROFILM (U.S. CLS. 21, 23, 26, 36 AND 38).

FIRST USE 10-23-2007; IN COMMERCE 10-23-2007.  
RAUL CORDOVA, EXAMINING ATTORNEY

---

SN 85-171,468. JDSM GLOBAL LLC, LEHIGH ACRES, FL.  
FILED 11-8-2010.

**The Science of Innovation**

THE MARK CONSISTS OF STANDARD CHARACTERS WITHOUT CLAIM TO ANY PARTICULAR FONT, STYLE, SIZE, OR COLOR.

FOR TELECOMMUNICATIONS AND DATA NETWORKING HARDWARE, NAMELY, DEVICES FOR TRANSPORTING AND AGGREGATING VOICE, DATA, AND VIDEO COMMUNICATIONS ACROSS MULTIPLE NETWORK INFRASTRUCTURES AND COMMUNICATIONS PROTOCOLS (U.S. CLS. 21, 23, 26, 36 AND 38).

BRENDAN REGAN, EXAMINING ATTORNEY

**CLASS 9—(Continued).**

SN 85-172,591. DATA WATCH TECHNOLOGIES CO., LTD.,  
NEI HU, TAIPEI, TAIWAN, FILED 11-9-2010.



The logo for dataTale features three vertical bars of increasing height on the left, followed by the word "dataTale" in a bold, sans-serif font.

THE MARK CONSISTS OF VERTICAL LINES WITH THE  
WORD "DATATALE" NEXT TO THE DESIGN.

FOR COMPUTER HARD DRIVE ENCLOSURES; COM-  
PUTER STORAGE DEVICES, NAMELY, HIGH-SPEED  
STORAGE SUBSYSTEMS FOR STORAGE AND BACKUP  
OF ELECTRONIC DATA EITHER LOCALLY OR VIA A  
TELECOMMUNICATIONS NETWORK; COMPUTER  
BACKUP AND STORAGE SYSTEMS WITH MULTIPLE  
REMOVABLE RAID CARTRIDGES; RAID-BASED HARD  
DRIVE BACKUP SYSTEMS; COMPUTER NETWORKING  
HARDWARE; INTERFACE CARDS FOR DATA PROCES-  
SING EQUIPMENT IN THE FORM OF PRINTED CIR-  
CUITS; COMPUTER CARD ADAPTER; COMPUTER  
NETWORK ADAPTERS, SWITCHES, ROUTERS AND  
HUBS; MEDIA PLAYERS; PORTABLE MEDIA PLAYERS  
(U.S. CLS. 21, 23, 26, 36 AND 38).

FIRST USE 1-0-2009; IN COMMERCE 1-0-2009.

KATHERINE M. DUBRAY, EXAMINING ATTORNEY

SN 85-173,043. CYBER SAMURAI MARKETING, INC, SAINT  
LOUIS, MO. FILED 11-9-2010.



The logo for 1AutomationWiz features a large, bold number "1" followed by the word "AutomationWiz" in a serif font.

THE MARK CONSISTS OF STANDARD CHARACTERS  
WITHOUT CLAIM TO ANY PARTICULAR FONT, STYLE,  
SIZE, OR COLOR.

FOR COMPUTER SOFTWARE FOR UTILIZING SHOP-  
PING CART TECHNOLOGY FOR WEBSITES (U.S. CLS.  
21, 23, 26, 36 AND 38).

FIRST USE 5-13-2004; IN COMMERCE 5-13-2004.

HENRY S. ZAK, EXAMINING ATTORNEY

**CLASS 9—(Continued).**

SN 85-173,071. LANGSDALE, DAVID J, MAPLE GROVE,  
MN. FILED 11-9-2010.



THE MARK CONSISTS OF A SMILING WOLF IN A  
WHEELCHAIR THAT IS POINTING UP TO THE WORD  
"LES'ABLED". HE HAS "DJ'S \*L \*OGIC" ON HIS CHEST  
AND THE PHRASE "IT'S "ONLY" PHYSICAL!" IS UNDER  
THE WHEELCHAIR.

FOR MOUSEPADS (U.S. CLS. 21, 23, 26, 36 AND 38).

HENRY S. ZAK, EXAMINING ATTORNEY

SN 85-173,072. B-ROLLER, ANCHORAGE, AK. FILED 11-9-  
2010.



THE MARK CONSISTS OF A CIRCLE WITH THE NEW  
TIMES ROMAN FONT CAPITAL LETTER "B" AT THE  
CENTER OF THE CIRCLE, AND THE WORD "ROLLER"  
WRITTEN IN BICKLEY SCRIPT FONT FOLLOWING THE  
CIRCLE "B" IMAGE.

FOR CAMERA STABILITY ACCESSORY, NAMELY, A  
SUPPORT ARM, VEST AND SLED FOR FILM AND  
VIDEO CAMERAS TO ABSORB SHAKING MOVES  
WHILE SHOOTING; PORTABLE PHOTOGRAPHY  
EQUIPMENT, NAMELY, REFLECTORS, TRIPODS,  
LIGHT STANDS AND SUPPORTS AND BAGS SPE-  
CIALY ADAPTED FOR THESE GOODS (U.S. CLS. 21,  
23, 26, 36 AND 38).

HENRY S. ZAK, EXAMINING ATTORNEY

**CLASS 9—(Continued).**

SN 85-173,575. CENTER FOR APPLICATIONS OF PSYCHOLOGICAL TYPE, INC., GAINESVILLE, FL. FILED 11-10-2010.

**CLASS 9—(Continued).**

SN 85-174,127. JINGHUA OPTICS AND ELECTRONICS CO., LTD., GANGZHOU; GUANGDONG, CHINA, FILED 11-11-2010.

YOUR LIFE. YOUR BEST.

THE MARK CONSISTS OF STANDARD CHARACTERS WITHOUT CLAIM TO ANY PARTICULAR FONT, STYLE, SIZE, OR COLOR.

FOR DOWNLOADABLE REPORTS IN THE FIELD OF HUMAN PERSONALITY, RELATIONS, PSYCHOLOGY AND DEVELOPMENT (U.S. CLS. 21, 23, 26, 36 AND 38).

FIRST USE 10-26-2010; IN COMMERCE 10-26-2010.  
ROSELLE HERRERA, EXAMINING ATTORNEY



---

SN 85-173,998. DIAMOND GAME, CHATSWORTH, CA. FILED 11-10-2010.

Blues N Bucks

THE MARK CONSISTS OF STANDARD CHARACTERS WITHOUT CLAIM TO ANY PARTICULAR FONT, STYLE, SIZE, OR COLOR.

FOR GAMING EQUIPMENT, NAMELY, ELECTRONIC GAMING MACHINES AND GAMING MACHINES WITH VIDEO OUTPUT (U.S. CLS. 21, 23, 26, 36 AND 38).  
KRISTINA MORRIS, EXAMINING ATTORNEY

OWNER OF U.S. REG. NO. 3,859,899.  
NO CLAIM IS MADE TO THE EXCLUSIVE RIGHT TO USE "SCIENTIFIC", APART FROM THE MARK AS SHOWN.

THE MARK CONSISTS OF THE WORDS "EXPLORE SCIENTIFIC" IN WHICH THE LETTER "O" IS REPLACED BY THREE CONCENTRIC CURVED LINES THAT ARE TOGETHER SUGGESTIVE OF THE LETTER "O".

FOR BODY-TUBES FOR TELESCOPES; OPTICAL OR TELESCOPIC LENS SIGHTS; TELESCOPES; TELESCOPIC GUN SIGHTS; TELESCOPIC LENS SIGHTS; TELESCOPIC SIGHTS (U.S. CLS. 21, 23, 26, 36 AND 38).

FIRST USE 6-4-2009; IN COMMERCE 6-4-2009.  
CAROLYN CATALDO, EXAMINING ATTORNEY

**CLASS 9—(Continued).**

SN 85-174,148. ACN INDUSTRY INC., CHICAGO, IL. FILED 11-11-2010.



THE COLOR(S) BLUE, RED IS/ARE CLAIMED AS A FEATURE OF THE MARK.

THE MARK CONSISTS OF FROM THE LEFT TO THE RIGHT IN SEQUENCE, BLUE UPPER LETTER "A", A RED COMBINATION OF SUN-SHINE OR PEDALS OF A SUN-FLOWER WHICH REPRESENT AND ARRANGED IN THE SHAPE OF LETTER "C", AND BLUE LOWER CASE LETTERS "NERGY".

FOR APPARATUS FOR CONVERTING ELECTRONIC RADIATION TO ELECTRICAL ENERGY, NAMELY, PHOTOVOLTAIC SOLAR HYBRID MODULES; APPARATUS FOR CONVERTING ELECTRONIC RADIATION TO ELECTRICAL ENERGY, NAMELY, PHOTOVOLTAIC SOLAR MODULES; APPARATUS FOR CONVERTING ELECTRONIC RADIATION TO ELECTRICAL ENERGY, NAMELY, PHOTOVOLTAIC THERMAL HYBRID MODULE; APPARATUS FOR CONVERTING ELECTRONIC RADIATION TO ELECTRICAL ENERGY, NAMELY, PHOTOVOLTAIC THERMAL MODULE; APPARATUS FOR CONVERTING ELECTRONIC RADIATION TO ELECTRICAL ENERGY, NAMELY, PVT (PHOTOVOLTAIC THERMAL) MODULE; ELECTRONICAL SENSORS FOR MEASURING SOLAR RADIATION; GATE OPERATORS POWERED BY BATTERY, ELECTRICITY OR SOLAR POWER; PHOTOVOLTAIC CELLS ALSO INCLUDING A SOLAR THERMAL COLLECTOR SOLD AS A UNIT; PHOTOVOLTAIC INSTALLATION APPARATUS, NAMELY, SOLAR MODULES FOR PRODUCTION OF ELECTRICITY, SOLAR THERMAL AND ELECTRIC RECEIVERS, TRACKING MECHANISMS AND CONCENTRATING OPTICS, AND CONTROL ALGORITHMS; PHOTOVOLTAIC SOLAR MODULES FOR PRODUCTION OF ELECTRICITY; SILICON SOLAR CELL MATERIAL FOR ELECTRICITY GENERATION INCORPORATED INTO PAVEMENT MATERIALS; SOLAR BATTERIES; SOLAR PANELS FOR PRODUCTION OF ELECTRICITY (U.S. CLS. 21, 23, 26, 36 AND 38).  
SHAUNIA CARLYLE, EXAMINING ATTORNEY

SN 85-174,259. NIMVIA, LLC, CHARLOTTE, NC. FILED 11-11-2010.

**VANGUARD**

THE MARK CONSISTS OF STANDARD CHARACTERS WITHOUT CLAIM TO ANY PARTICULAR FONT, STYLE, SIZE, OR COLOR.

FOR PRACTICE MANAGEMENT SOFTWARE, NAMELY, DOWNLOADABLE COMPUTER SOFTWARE FOR DOCKETING AND CASE MANAGEMENT IN THE FIELD OF PATENT PROSECUTION BEFORE THE U.S. PATENT AND TRADEMARK OFFICE; PRACTICE MANAGEMENT SOFTWARE, NAMELY, DOWNLOADABLE COMPUTER SOFTWARE FOR INTERACTING WITH ONLINE COMPUTER SYSTEMS OF THE U.S. PATENT AND TRADEMARK OFFICE (U.S. CLS. 21, 23, 26, 36 AND 38).

PAUL E. FAHRENKOPF, EXAMINING ATTORNEY

**CLASS 9—(Continued).**

SN 85-174,598. FUJIFILM NORTH AMERICA CORPORATION, VALHALLA, NY. FILED 11-11-2010.

**LIFE WAS MADE FOR 3D**

THE MARK CONSISTS OF STANDARD CHARACTERS WITHOUT CLAIM TO ANY PARTICULAR FONT, STYLE, SIZE, OR COLOR.

FOR DIGITAL CAMERAS AND DIGITAL CAMERA CASES (U.S. CLS. 21, 23, 26, 36 AND 38).  
FIRST USE 9-24-2010; IN COMMERCE 9-24-2010.  
REBECCA EISINGER, EXAMINING ATTORNEY

SN 85-174,869. SCT PERFORMANCE, LLC, LONGWOOD, FL. FILED 11-11-2010.

**THE TUNING BRAND YOU CAN TRUST**

THE MARK CONSISTS OF STANDARD CHARACTERS WITHOUT CLAIM TO ANY PARTICULAR FONT, STYLE, SIZE, OR COLOR.

FOR AUTOMOTIVE TUNING DEVICE, NAMELY, ELECTRONIC CONTROL HARDWARE UNIT WHICH INTERFACES WITH A VEHICLE'S DRIVE-TRAIN COMPUTER SYSTEM AND REPROGRAMS THE VEHICLE'S MICROCHIP TO MAKE IT ENHANCE THE PERFORMANCE OF THE VEHICLE (U.S. CLS. 21, 23, 26, 36 AND 38).  
FIRST USE 11-2-2010; IN COMMERCE 11-2-2010.  
KELLY TRUSILO, EXAMINING ATTORNEY

SN 85-174,884. SCT PERFORMANCE, LLC, LONGWOOD, FL. FILED 11-11-2010.

**THE TUNER YOU CAN TRUST**

THE MARK CONSISTS OF STANDARD CHARACTERS WITHOUT CLAIM TO ANY PARTICULAR FONT, STYLE, SIZE, OR COLOR.

FOR AUTOMOTIVE TUNING DEVICE, NAMELY, ELECTRONIC CONTROL HARDWARE UNIT WHICH INTERFACES WITH A VEHICLE'S DRIVE-TRAIN COMPUTER SYSTEM AND REPROGRAMS THE VEHICLE'S MICROCHIP TO MAKE IT ENHANCE THE PERFORMANCE OF THE VEHICLE (U.S. CLS. 21, 23, 26, 36 AND 38).

KELLY TRUSILO, EXAMINING ATTORNEY

**CLASS 9—(Continued).**

SN 85-174,885. CENTRANCE, INC., MORTON GROVE, IL.  
FILED 11-11-2010.

**MIXERFACE**

THE MARK CONSISTS OF STANDARD CHARACTERS  
WITHOUT CLAIM TO ANY PARTICULAR FONT, STYLE,  
SIZE, OR COLOR.

FOR USB AUDIO INTERFACES, NAMELY, USB  
HARDWARE (U.S. CLS. 21, 23, 26, 36 AND 38).  
EMILY CHUO, EXAMINING ATTORNEY

SN 85-174,890. SCT PERFORMANCE, LLC, LONGWOOD, FL.  
FILED 11-11-2010.

**THE BRAND YOU CAN TRUST**

THE MARK CONSISTS OF STANDARD CHARACTERS  
WITHOUT CLAIM TO ANY PARTICULAR FONT, STYLE,  
SIZE, OR COLOR.

FOR AUTOMOTIVE TUNING DEVICE, NAMELY,  
ELECTRONIC CONTROL HARDWARE UNIT WHICH  
INTERFACES WITH A VEHICLE'S DRIVE-TRAIN COM-  
PUTER SYSTEM AND REPROGRAMS THE VEHICLE'S  
MICROCHIP TO MAKE IT ENHANCE THE PERFOR-  
MANCE OF THE VEHICLE (U.S. CLS. 21, 23, 26, 36 AND  
38).

KELLY TRUSILO, EXAMINING ATTORNEY

SN 85-175,062. HIPSOFT, LLC, REDMOND, WA. FILED 11-  
11-2010.



FOR COMPUTER GAME SOFTWARE; COMPUTER  
GAME SOFTWARE FOR USE ON MOBILE AND CEL-  
LULAR PHONES; ELECTRONIC GAME SOFTWARE;  
ELECTRONIC GAME SOFTWARE FOR HANDHELD  
ELECTRONIC DEVICES; VIDEO GAME SOFTWARE  
(U.S. CLS. 21, 23, 26, 36 AND 38).

MARIA-VICTORIA SUAREZ, EXAMINING ATTORNEY

**CLASS 9—(Continued).**

SN 85-175,311. THE CHICAGO ZOOLOGICAL SOCIETY,  
BROOKFIELD, IL. FILED 11-12-2010.

**ETHOTRAK**

THE MARK CONSISTS OF STANDARD CHARACTERS  
WITHOUT CLAIM TO ANY PARTICULAR FONT, STYLE,  
SIZE, OR COLOR.

FOR SOFTWARE FOR TRACKING AND ANALYZING  
ANIMAL BEHAVIOR (U.S. CLS. 21, 23, 26, 36 AND 38).  
FIRST USE 1-26-2005; IN COMMERCE 1-26-2005.  
KAREN K. BUSH, EXAMINING ATTORNEY

SN 85-175,335. NEWCARDIO, INC., SANTA CLARA, CA.  
FILED 11-12-2010.

**my3KG**

THE MARK CONSISTS OF STANDARD CHARACTERS  
WITHOUT CLAIM TO ANY PARTICULAR FONT, STYLE,  
SIZE, OR COLOR.

FOR SOFTWARE FOR USE WITH MEDICAL DETEC-  
TION AND DIAGNOSIS DEVICES, NAMELY, IN THE  
FIELD OF ELECTROCARDIOGRAPHY (ECG) (U.S. CLS.  
21, 23, 26, 36 AND 38).

STEVEN R. FINE, EXAMINING ATTORNEY

SN 85-175,479. SAM ASH MUSIC CORPORATION, HICKS-  
VILLE, NY. FILED 11-12-2010.

**SAMSON METEOR MIC**

THE MARK CONSISTS OF STANDARD CHARACTERS  
WITHOUT CLAIM TO ANY PARTICULAR FONT, STYLE,  
SIZE, OR COLOR.

OWNER OF U.S. REG. NOS. 1,146,100, 3,160,361 AND  
OTHERS.

NO CLAIM IS MADE TO THE EXCLUSIVE RIGHT TO  
USE "MIC", APART FROM THE MARK AS SHOWN.

FOR MICROPHONES (U.S. CLS. 21, 23, 26, 36 AND 38).  
INGA ERVIN, EXAMINING ATTORNEY



**CLASS 9—(Continued).**

SN 85-175,824. AIR AUTOMOTIVE TRACKING INC, AKA AAT INC, CONCORD, ONTARIO, CANADA, FILED 11-12-2010.

# AirLoom

THE MARK CONSISTS OF STANDARD CHARACTERS WITHOUT CLAIM TO ANY PARTICULAR FONT, STYLE, SIZE, OR COLOR.

FOR COMPUTER HARDWARE AND SOFTWARE SYSTEM FOR TRACKING PEOPLE, OBJECTS AND PETS USING GPS DATA ON A DEVICE ON THE TRACKED PEOPLE, OBJECTS AND PETS; COMPUTER HARDWARE AND SOFTWARE, FOR USE WITH MEDICAL PATIENT MONITORING EQUIPMENT, FOR RECEIVING, PROCESSING, TRANSMITTING AND DISPLAYING DATA; COMPUTER HARDWARE FOR TELECOMMUNICATIONS; COMPUTER HARDWARE FOR WIRELESS CONTENT DELIVERY; ELECTRONIC COMMUNICATIONS SYSTEMS COMPRISED OF COMPUTER HARDWARE AND SOFTWARE FOR THE TRANSMISSION OF DATA BETWEEN TWO POINTS; ELECTRONIC DEVICES FOR ANIMAL LOCATING AND TRACKING PROGRAMMED TO USE GLOBAL POSITIONING SYSTEMS (GPS) AND CELLULAR COMMUNICATIONS; GLOBAL POSITIONING SYSTEM (GPS); GLOBAL POSITIONING SYSTEM (GPS) CONSISTING OF COMPUTERS, COMPUTER SOFTWARE, TRANSMITTERS, RECEIVERS, AND NETWORK INTERFACE DEVICES; GPS / GSM TRACKING DEVICE TO BE WORN ON THE WRIST OF AN ATHLETE DURING ENDURANCE EVENTS; GPS DATA LOGGER FOR RECORDING TRIPS AND CLASSIFYING THEM INTO DIFFERENT ACCOUNTS; GPS NAVIGATION DEVICE; VEHICLE LOCATOR AND RECOVERY DEVICE PROGRAMMED TO USE GLOBAL POSITIONING SYSTEMS (GPS) AND CELLULAR TELECOMMUNICATIONS; VEHICLE MOUNTED GPS SENSOR FOR DETERMINING THE RATE OF MOTION FOR A VEHICLE (U.S. CLS. 21, 23, 26, 36 AND 38).

FIRST USE 10-1-2010; IN COMMERCE 11-8-2010.  
PAUL MORENO, EXAMINING ATTORNEY

SN 85-175,876. BUFFALO TECHNOLOGY (USA), INC., AUSTIN, TX. FILED 11-12-2010.

# CLOUDSTOR

THE MARK CONSISTS OF STANDARD CHARACTERS WITHOUT CLAIM TO ANY PARTICULAR FONT, STYLE, SIZE, OR COLOR.

FOR A SHARED NETWORK STORAGE DEVICE UTILIZING FILE SHARING TECHNOLOGY WHICH INCLUDES FREE ONLINE SERVICE FOR REMOTELY ACCESSING AND SHARING FILES THROUGH ANY WEB BROWSER (U.S. CLS. 21, 23, 26, 36 AND 38).

JESSICA A. POWERS, EXAMINING ATTORNEY

**CLASS 9—(Continued).**

SN 85-175,903. TAE, SANG HO, HELENDALE, CA. FILED 11-12-2010.

# ECHO NINER

THE MARK CONSISTS OF STANDARD CHARACTERS WITHOUT CLAIM TO ANY PARTICULAR FONT, STYLE, SIZE, OR COLOR.

FOR BAGS FOR CAMERAS AND PHOTOGRAPHIC EQUIPMENT (U.S. CLS. 21, 23, 26, 36 AND 38).  
NATALIE POLZER, EXAMINING ATTORNEY

SN 85-176,023. SIXENSE ENTERTAINMENT, INC., LOS GATOS, CA. FILED 11-12-2010.

# Motion Touch

THE MARK CONSISTS OF STANDARD CHARACTERS WITHOUT CLAIM TO ANY PARTICULAR FONT, STYLE, SIZE, OR COLOR.

FOR COMPUTER GAME JOYSTICKS; COMPUTER GAME SOFTWARE FOR GAMING MACHINES, NAMELY, SLOT MACHINES AND VIDEO LOTTERY TERMINALS; COMPUTER GAME SOFTWARE FOR PERSONAL COMPUTERS AND HOME VIDEO GAME CONSOLES; COMPUTER GAME SOFTWARE FOR USE ON MOBILE AND CELLULAR PHONES; COMPUTER GRAPHICS SOFTWARE; COMPUTER SOFTWARE FOR CREATING AND EDITING MUSIC AND SOUNDS (U.S. CLS. 21, 23, 26, 36 AND 38).

FIRST USE 9-30-2010; IN COMMERCE 9-30-2010.  
DOMINIC J. FERRAIUOLO, EXAMINING ATTORNEY

SN 85-176,101. SENSORY ACUMEN, INC., ORINDA, CA. FILED 11-13-2010.

# gaMedSkunk

THE MARK CONSISTS OF STANDARD CHARACTERS WITHOUT CLAIM TO ANY PARTICULAR FONT, STYLE, SIZE, OR COLOR.

FOR COMPUTER HARDWARE AND COMPUTER PERIPHERAL DEVICES (U.S. CLS. 21, 23, 26, 36 AND 38).  
MATTHEW PAPPAS, EXAMINING ATTORNEY

**CLASS 9—(Continued).**

SN 85-176,424. TRANSEQUATORIAL SOLUTIONS, INC.,  
GALLANT, AL. FILED 11-15-2010.

# ScopeCard

THE MARK CONSISTS OF STANDARD CHARACTERS WITHOUT CLAIM TO ANY PARTICULAR FONT, STYLE, SIZE, OR COLOR.

FOR GUN SCOPES; RIFLE SCOPES; RIFLESCOPES; SPOTTING SCOPES (U.S. CLS. 21, 23, 26, 36 AND 38).  
APRIL ROACH, EXAMINING ATTORNEY

SN 85-176,532. KUUZUU, INC., SAN FRANCISCO, CA.  
FILED 11-15-2010.

# KUUZUU

THE MARK CONSISTS OF STANDARD CHARACTERS WITHOUT CLAIM TO ANY PARTICULAR FONT, STYLE, SIZE, OR COLOR.

FOR WIRELESS VIDEO CAMERAS; COMPUTER APPLICATION SOFTWARE FOR MOBILE PHONES AND OTHER WIRELESS DEVICES, NAMELY, SOFTWARE FOR USE IN RECORDING, TRANSMITTING, VIEWING, STORING, ARCHIVING, UPLOADING, DISPLAYING AND SHARING AUDIO AND VIDEO CONTENT (U.S. CLS. 21, 23, 26, 36 AND 38).

JACLYN KIDWELL WALKER, EXAMINING ATTORNEY

SN 85-176,594. MIL HOLDINGS, BIRMINGHAM, AL. FILED  
11-15-2010.



THE MARK CONSISTS OF THE STYLIZED TEXT "MY INTEGRATED LIFE" THE "Y" IS A PERSON WITH HIS ARMS UP AND A PHONE IN THE BACKGROUND WITH THREE BARS.

FOR COMPUTERS (U.S. CLS. 21, 23, 26, 36 AND 38).  
VIVIAN MICZNIK FIRST, EXAMINING ATTORNEY

**CLASS 9—(Continued).**

SN 85-176,631. HACHETTE FILIPACCHI MEDIA U.S., INC.,  
NEW YORK, NY. FILED 11-15-2010.

# RECTHIS

THE MARK CONSISTS OF STANDARD CHARACTERS WITHOUT CLAIM TO ANY PARTICULAR FONT, STYLE, SIZE, OR COLOR.

FOR COMPUTER SOFTWARE, NAMELY, MOBILE APPLICATION TO ASSIST CONSUMERS IN PRODUCTION OF VIDEOS VIA MOBILE COMMUNICATIONS DEVICES (U.S. CLS. 21, 23, 26, 36 AND 38).

WILLIAM BRECKENFELD, EXAMINING ATTORNEY

SN 85-176,874. LEONARD DORIAN ROSS, SOUTHURY,  
CT. FILED 11-15-2010.

# BIG TIME CRUSH

THE MARK CONSISTS OF STANDARD CHARACTERS WITHOUT CLAIM TO ANY PARTICULAR FONT, STYLE, SIZE, OR COLOR.

FOR COMPUTER APPLICATION SOFTWARE FOR MOBILE PHONES AND COMPUTERS, NAMELY, SOFTWARE FOR MATCHING USERS WITH OTHER USERS AND USERS WITH SHARED INTERESTS; COMPUTER GAME PROGRAMMES; COMPUTER GAME PROGRAMMES DOWNLOADABLE VIA THE INTERNET; COMPUTER GAME PROGRAMS; COMPUTER GAME PROGRAMS, CARTRIDGES, AND CASSETTES; COMPUTER GAME SOFTWARE; COMPUTER GAME SOFTWARE DOWNLOADABLE FROM A GLOBAL COMPUTER NETWORK; COMPUTER GAME SOFTWARE FOCUSING ON ACHIEVING A SET OF GOALS, POSITIONS, OWNERSHIP, AND CREDENTIALS, AND PROFESSIONAL AND SOCIAL STATUS, AND GOOD FORTUNE NECESSARY TO SUCCEED PROFESSIONALLY AND PERSONALLY, AND NOT REFERRING EITHER TO A GROUP OF SOFTWARE FOR USE IN COMMERCE OR TO A GROUP OF OFFICES; COMPUTER GAME SOFTWARE FOR PERSONAL COMPUTERS AND HOME VIDEO GAME CONSOLES; COMPUTER GAME SOFTWARE FOR USE ON MOBILE AND CELLULAR PHONES; COMPUTER GAME SOFTWARE FOR USE WITH PERSONAL COMPUTERS, HOME VIDEO GAME CONSOLES USED WITH TELEVISIONS AND ARCADE-BASED VIDEO GAME CONSOLES; COMPUTER SOFTWARE FOR USERS TO FIND OTHER USERS THAT SHARE SIMILAR INTERESTS; COMPUTER SOFTWARE FOR USERS TO FIND OTHER USERS THAT SHARE SIMILAR INTERESTS THAT MAY BE DOWNLOADED FROM A GLOBAL COMPUTER NETWORK; DOWNLOADABLE COMPUTER GAME SOFTWARE VIA A GLOBAL COMPUTER NETWORK AND WIRELESS DEVICES (U.S. CLS. 21, 23, 26, 36 AND 38).

DAVID HOFFMAN, EXAMINING ATTORNEY

**CLASS 9—(Continued).**

SN 85-176,892. VENTERA CORPORATION, RESTON, VA. FILED 11-15-2010.

**VENTERA ADAPT**

THE MARK CONSISTS OF STANDARD CHARACTERS WITHOUT CLAIM TO ANY PARTICULAR FONT, STYLE, SIZE, OR COLOR.

FOR SOFTWARE THAT ALLOWS USER-DEFINED CLEANSING QUERIES TO BE CREATED AND EXECUTED VIA DYNAMICALLY GENERATED SQL IN SUPPORT OF DATA CLEANSING ANALYSIS, AND WHICH CREATES AUTOMATED OUTPUT FILES AND REPORTS DOCUMENTING THE RESULTS OF THOSE QUERIES (U.S. CLS. 21, 23, 26, 36 AND 38).

MARK PILARO, EXAMINING ATTORNEY

**CLASS 9—(Continued).**

SN 85-176,950. LOGAH TECHNOLOGY CORPORATION, HSINCHU COUNTY 302, TAIWAN, FILED 11-15-2010.



THE MARK CONSISTS OF A STYLIZED FORM OF THE WORD "LOGAH".

FOR INVERTERS; CONVERTERS; POWER SUPPLIES FOR MONITOR USE; ELECTRICAL POWER SUPPLIES (U.S. CLS. 21, 23, 26, 36 AND 38).

KATHERINE STOIDES, EXAMINING ATTORNEY

SN 85-176,906. JERRY HARVEY AUDIO, LLC, DBA JH AUDIO, APOPKA, FL. FILED 11-15-2010.



THE MARK CONSISTS OF THE DEPICTION OF A FLYING LADY WITH WINGS.

FOR EARPHONES, HEADPHONES, HEADSETS, SPEAKERS, AMPLIFIERS, CABLES FOR USE WITH EARPHONES, HEADPHONES, HEADSETS, AMPLIFIERS AND SPEAKERS (U.S. CLS. 21, 23, 26, 36 AND 38).

FIRST USE 7-23-2008; IN COMMERCE 7-23-2008.  
KATHERINE STOIDES, EXAMINING ATTORNEY

SN 85-176,985. PKWARE, INC., MILWAUKEE, WI. FILED 11-15-2010.

**ZIPABLE**

SN 85-176,925. GREEN JR., AARON, NOKESVILLE, VA. FILED 11-15-2010.

**MISTA GREEN**

THE MARK CONSISTS OF STANDARD CHARACTERS WITHOUT CLAIM TO ANY PARTICULAR FONT, STYLE, SIZE, OR COLOR.

FOR DOWNLOADABLE MUSICAL SOUND RECORDINGS; DOWNLOADABLE VIDEO RECORDINGS FEATURING MUSIC; PRERECORDED CD'S FEATURING MUSIC (U.S. CLS. 21, 23, 26, 36 AND 38).

KATHERINE STOIDES, EXAMINING ATTORNEY

THE MARK CONSISTS OF STANDARD CHARACTERS WITHOUT CLAIM TO ANY PARTICULAR FONT, STYLE, SIZE, OR COLOR.

FOR COMPUTER PROGRAMS AND INSTRUCTIONAL MANUALS SOLD AS A UNIT FOR COMPRESSION, DECOMPRESSION, LIBRARYING AND ARCHIVING OF COMPUTER FILES (U.S. CLS. 21, 23, 26, 36 AND 38).

MATTHEW KLINE, EXAMINING ATTORNEY

**CLASS 9—(Continued).**

SN 85-177,008. CHERWELL SOFTWARE, INC., COLORADO SPRINGS, CO. FILED 11-15-2010.



The logo features a stylized, wavy line above the word "CHERWELL" in a large, serif font. Below "CHERWELL" is the phrase "SERVICE MANAGEMENT" in a smaller, all-caps, sans-serif font.

OWNER OF U.S. REG. NO. 3,455,485.

NO CLAIM IS MADE TO THE EXCLUSIVE RIGHT TO USE "SERVICE MANAGEMENT", APART FROM THE MARK AS SHOWN.

THE MARK CONSISTS OF A THICK, WAVY LINE, WITH ANOTHER LINE BREAKING OFF ON TOP AND FORMING A STYLIZED "C". THE WORDS "CHERWELL SERVICE MANAGEMENT" APPEAR BELOW THE DESIGN.

FOR COMPUTER SOFTWARE AND INSTRUCTIONAL MANUALS SOLD AS A UNIT AND USED TO AUTOMATE THE PROCESSES RELATED TO HELP DESK SUPPORT FOR INFORMATION TECHNOLOGY, AND USED BY MARKETING, SALES AND CUSTOMER SERVICE PERSONNEL TO AUTOMATE THE PROCESSES RELATED TO CUSTOMER ACQUISITION AND RETENTION, INCLUDING MARKETING CAMPAIGNS, SALES LEAD GENERATION, SALES CALL CONTACT AND FOLLOW-UP, CUSTOMER ORDERS AND ONGOING CUSTOMER SERVICE AND SUPPORT (U.S. CLS. 21, 23, 26, 36 AND 38).

FIRST USE 11-1-2008; IN COMMERCE 12-0-2008.  
LAURIE MAYES, EXAMINING ATTORNEY

SN 85-177,011. CABLES & ETC. LLC, OAKLAND, CA. FILED 11-15-2010.

**C&E**

THE MARK CONSISTS OF STANDARD CHARACTERS WITHOUT CLAIM TO ANY PARTICULAR FONT, STYLE, SIZE, OR COLOR.

FOR AUDIO CABLES; CABLE MODEMS; COMPUTER CABLES; ELECTRONIC CABLES; ETHERNET CABLES; FIBER OPTIC CABLES; MICROPHONE CABLES; MODEM CABLES; POWER CABLES; PRINTER CABLES; STEREO CABLES; TELECOMMUNICATION CABLES; USB CABLES; VIDEO CABLES (U.S. CLS. 21, 23, 26, 36 AND 38).

LAURIE MAYES, EXAMINING ATTORNEY

**CLASS 9—(Continued).**

SN 85-177,021. GE INFRASTRUCTURE SENSING, INC., BILLARICA, MA. FILED 11-15-2010.

**TERPS**

THE MARK CONSISTS OF STANDARD CHARACTERS WITHOUT CLAIM TO ANY PARTICULAR FONT, STYLE, SIZE, OR COLOR.

FOR PRESSURE SENSORS (U.S. CLS. 21, 23, 26, 36 AND 38).

JEFFREY LOOK, EXAMINING ATTORNEY

SN 85-177,144. R. READY PRODUCTIONS, INC., CHARLOTTE, NC. FILED 11-15-2010.

**iDriver**

THE MARK CONSISTS OF STANDARD CHARACTERS WITHOUT CLAIM TO ANY PARTICULAR FONT, STYLE, SIZE, OR COLOR.

FOR DOWNLOADABLE ELECTRONIC NEWSLETTERS DELIVERED BY E-MAIL IN THE FIELD OF AUTOMOTIVES (U.S. CLS. 21, 23, 26, 36 AND 38).

FIRST USE 6-11-2010; IN COMMERCE 6-11-2010.  
YAT SYE, LEE, EXAMINING ATTORNEY

SN 85-177,300. BACKFLIP STUDIOS, INC., BOULDER, CO. FILED 11-15-2010.

**GRAFFITI BALL**

THE MARK CONSISTS OF STANDARD CHARACTERS WITHOUT CLAIM TO ANY PARTICULAR FONT, STYLE, SIZE, OR COLOR.

FOR COMPUTER SOFTWARE AND DOWNLOADABLE SOFTWARE IN THE FIELD OF GAMES FOR USE ON COMPUTERS AND MOBILE COMMUNICATIONS DEVICES (U.S. CLS. 21, 23, 26, 36 AND 38).

FIRST USE 7-8-2010; IN COMMERCE 7-8-2010.  
BRENDAN REGAN, EXAMINING ATTORNEY

**CLASS 9—(Continued).**

SN 85-177,302. BACKFLIP STUDIOS, INC., BOULDER, CO. FILED 11-15-2010.

**CLASS 9—(Continued).**

SN 85-177,307. BACKFLIP STUDIOS, INC., BOULDER, CO. FILED 11-15-2010.

# STRIKE KNIGHT

THE MARK CONSISTS OF STANDARD CHARACTERS WITHOUT CLAIM TO ANY PARTICULAR FONT, STYLE, SIZE, OR COLOR.

FOR COMPUTER SOFTWARE AND DOWNLOADABLE SOFTWARE IN THE FIELD OF GAMES FOR USE ON COMPUTERS AND MOBILE COMMUNICATIONS DEVICES (U.S. CLS. 21, 23, 26, 36 AND 38).

FIRST USE 5-17-2010; IN COMMERCE 5-17-2010.  
BRENDAN REGAN, EXAMINING ATTORNEY

# NINJUMP

THE MARK CONSISTS OF STANDARD CHARACTERS WITHOUT CLAIM TO ANY PARTICULAR FONT, STYLE, SIZE, OR COLOR.

FOR COMPUTER SOFTWARE AND DOWNLOADABLE SOFTWARE IN THE FIELD OF GAMES FOR USE ON COMPUTERS AND MOBILE COMMUNICATIONS DEVICES (U.S. CLS. 21, 23, 26, 36 AND 38).

FIRST USE 8-12-2010; IN COMMERCE 8-12-2010.  
BRENDAN REGAN, EXAMINING ATTORNEY

---

SN 85-177,303. BACKFLIP STUDIOS, INC., BOULDER, CO. FILED 11-15-2010.

# DR. SHOCKER

THE MARK CONSISTS OF STANDARD CHARACTERS WITHOUT CLAIM TO ANY PARTICULAR FONT, STYLE, SIZE, OR COLOR.

FOR COMPUTER SOFTWARE AND DOWNLOADABLE SOFTWARE IN THE FIELD OF GAMES FOR USE ON COMPUTERS AND MOBILE COMMUNICATIONS DEVICES (U.S. CLS. 21, 23, 26, 36 AND 38).

BRENDAN REGAN, EXAMINING ATTORNEY

---

SN 85-177,422. SOLUCOMP INC., SCHAUMBURG, IL. FILED 11-16-2010.

---

SN 85-177,305. BACKFLIP STUDIOS, INC., BOULDER, CO. FILED 11-15-2010.

# eSP 1000

# DYNAMITE SURFER

THE MARK CONSISTS OF STANDARD CHARACTERS WITHOUT CLAIM TO ANY PARTICULAR FONT, STYLE, SIZE, OR COLOR.

FOR COMPUTER SOFTWARE AND DOWNLOADABLE SOFTWARE IN THE FIELD OF GAMES FOR USE ON COMPUTERS AND MOBILE COMMUNICATIONS DEVICES (U.S. CLS. 21, 23, 26, 36 AND 38).

BRENDAN REGAN, EXAMINING ATTORNEY

THE MARK CONSISTS OF STANDARD CHARACTERS WITHOUT CLAIM TO ANY PARTICULAR FONT, STYLE, SIZE, OR COLOR.

FOR COMPUTER HARDWARE FOR TELECOMMUNICATIONS (U.S. CLS. 21, 23, 26, 36 AND 38).

ERNEST SHOSHO, EXAMINING ATTORNEY

**CLASS 9—(Continued).**

SN 85-177,479. KABUSHIKI KAISHA SQUARE ENIX, TA SQUARE ENIX CO., LTD., TOKYO, JAPAN, FILED 11-16-2010.

**ARMY CORPS OF HELL**

THE MARK CONSISTS OF STANDARD CHARACTERS WITHOUT CLAIM TO ANY PARTICULAR FONT, STYLE, SIZE, OR COLOR.

FOR COMPUTER GAME SOFTWARE; VIDEO GAME SOFTWARE; SOUND RECORDINGS IN THE FORM OF OPTICAL DISCS, MAGNETIC DISCS AND SEMICONDUCTOR ROMS FEATURING MUSIC AND FICTIONAL STORIES; AUDIO VISUAL RECORDINGS IN THE FORM OF OPTICAL DISCS, MAGNETIC DISCS AND SEMICONDUCTOR ROMS FEATURING MUSIC AND ANIMATED FICTIONAL STORIES; PRERECORDED COMPACT DISCS FEATURING MUSIC; PRERECORDED VIDEO DISCS FEATURING MUSIC AND ANIMATED FICTIONAL STORIES; MOUSE PADS; STRAPS FOR CELLULAR PHONES; VIDEO GAME CONTROLLERS; DOWNLOADABLE MUSICAL SOUND RECORDINGS; DOWNLOADABLE RING TONES FOR MOBILE PHONES; DOWNLOADABLE WALLPAPER GRAPHICS FOR MOBILE PHONES; DOWNLOADABLE ELECTRONIC PUBLICATIONS IN THE NATURE OF MAGAZINES, JOURNALS AND NEWSLETTERS IN THE FIELD OF COMPUTER GAMES AND VIDEO GAMES (U.S. CLS. 21, 23, 26, 36 AND 38).

HANNO RITTNER, EXAMINING ATTORNEY

SN 85-177,521. BELVILLE, JOSE MANUEL, ALBUQUERQUE, NM. FILED 11-16-2010.

**PRISTINA**

THE MARK CONSISTS OF STANDARD CHARACTERS WITHOUT CLAIM TO ANY PARTICULAR FONT, STYLE, SIZE, OR COLOR.

FOR PRE-RECORDED CDS FEATURING MUSIC; PRE-RECORDED DIGITAL MEDIA FEATURING MUSIC (U.S. CLS. 21, 23, 26, 36 AND 38).

FIRST USE 5-5-2005; IN COMMERCE 5-5-2005.

THEODORE MCBRIDE, EXAMINING ATTORNEY

**CLASS 9—(Continued).**

SN 85-177,546. BETHESDA SOFTWORKS LLC, ROCKVILLE, MD. FILED 11-16-2010.

**FALLOUT: NEW VEGAS DEAD MONEY**

THE MARK CONSISTS OF STANDARD CHARACTERS WITHOUT CLAIM TO ANY PARTICULAR FONT, STYLE, SIZE, OR COLOR.

OWNER OF U.S. REG. NOS. 2,181,084, 3,829,958 AND OTHERS.

FOR COMPUTER GAME SOFTWARE FOR USE WITH COMPUTERS AND VIDEO GAME CONSOLES; DOWNLOADABLE COMPUTER GAME SOFTWARE OFFERED VIA THE INTERNET AND WIRELESS DEVICES (U.S. CLS. 21, 23, 26, 36 AND 38).

COLLEEN KEARNEY, EXAMINING ATTORNEY

SN 85-177,901. THE CARTOON NETWORK, INC., ATLANTA, GA. FILED 11-16-2010.

**THE PROFESSOR BROTHERS**

THE MARK CONSISTS OF STANDARD CHARACTERS WITHOUT CLAIM TO ANY PARTICULAR FONT, STYLE, SIZE, OR COLOR.

FOR DVDS FEATURING ENTERTAINMENT, NAMELY, ANIMATION, COMEDY, ACTION AND ADVENTURE FOR YOUNG ADULTS AND ADULTS; DOWNLOADABLE PRE-RECORDED VIDEO RECORDING FEATURING ANIMATION, COMEDY, ACTION AND ADVENTURE; DOWNLOADABLE MULTIMEDIA FILES CONTAINING TEXT AND GRAPHICS FEATURING ANIMATION, COMEDY, ACTION AND ADVENTURE (U.S. CLS. 21, 23, 26, 36 AND 38).

FRED CARL, EXAMINING ATTORNEY

SN 85-177,989. J-NET WARNINGS, LLC, WICHITA, KS. FILED 11-16-2010.

**J-NET**

THE MARK CONSISTS OF STANDARD CHARACTERS WITHOUT CLAIM TO ANY PARTICULAR FONT, STYLE, SIZE, OR COLOR.

FOR OUTDOOR SIREN FOR WARNING THE APPROACH OF A DANGEROUS STORM (U.S. CLS. 21, 23, 26, 36 AND 38).

ANDREA HACK, EXAMINING ATTORNEY

**CLASS 9—(Continued).**

SN 85-178,218. SIMRAN INC., ELK GROVE VILLAGE, IL.  
FILED 11-16-2010.

**SMF-200**

THE MARK CONSISTS OF STANDARD CHARACTERS WITHOUT CLAIM TO ANY PARTICULAR FONT, STYLE, SIZE, OR COLOR.

FOR ELECTRICAL POWER SUPPLIES, NAMELY, VOLTAGE CONVERTERS, POWER CONVERTERS, AC/DC ADAPTERS, PLUG CONVERTERS, VOLTAGE SURGE PROTECTORS, VOLTAGE STABILIZERS, AND TRANSFORMERS (U.S. CLS. 21, 23, 26, 36 AND 38).

FIRST USE 10-1-2000; IN COMMERCE 10-1-2000.  
BRENDAN REGAN, EXAMINING ATTORNEY

SN 85-178,268. MEDAXIS CORPORATION, SANTA MONICA, CA. FILED 11-16-2010.

**360EHR**

THE MARK CONSISTS OF STANDARD CHARACTERS WITHOUT CLAIM TO ANY PARTICULAR FONT, STYLE, SIZE, OR COLOR.

FOR COMPUTER SOFTWARE FOR CONTROLLING AND MANAGING PATIENT MEDICAL INFORMATION (U.S. CLS. 21, 23, 26, 36 AND 38).

FIRST USE 1-9-2010; IN COMMERCE 3-9-2010.  
TINA MAI, EXAMINING ATTORNEY

SN 85-178,302. RAG & BONE HOLDINGS, LLC, NEW YORK, NY. FILED 11-16-2010.

**RAG & BONE**

THE MARK CONSISTS OF STANDARD CHARACTERS WITHOUT CLAIM TO ANY PARTICULAR FONT, STYLE, SIZE, OR COLOR.

OWNER OF U.S. REG. NOS. 2,906,967 AND 3,755,755.  
FOR EYEWEAR, NAMELY SUNGLASSES, EYEGLASS FRAMES, EYEWEAR CASES AND EYEGLASS CHAINS (U.S. CLS. 21, 23, 26, 36 AND 38).

FIRST USE 10-1-2009; IN COMMERCE 10-1-2009.  
GEORGE LORENZO, EXAMINING ATTORNEY

**CLASS 9—(Continued).**

SN 85-178,381. BALLY GAMING, INC., DBA BALLY TECHNOLOGIES, LAS VEGAS, NV. FILED 11-16-2010.

**WHITE LIGHTNING**

THE MARK CONSISTS OF STANDARD CHARACTERS WITHOUT CLAIM TO ANY PARTICULAR FONT, STYLE, SIZE, OR COLOR.

FOR COMPUTER GAMING SOFTWARE, GAMING SOFTWARE THAT GENERATES OR DISPLAYS WAGER OUTCOMES OF GAMING MACHINES, DOWNLOADABLE COMPUTER GAME SOFTWARE FOR GAMING, GAMING MACHINES, NAMELY, DEVICES THAT ACCEPT A WAGER, SLOT MACHINES (U.S. CLS. 21, 23, 26, 36 AND 38).

FIRST USE 10-14-2008; IN COMMERCE 10-14-2008.  
ANDREW RHIM, EXAMINING ATTORNEY

SN 85-178,385. REALNETWORKS, INC., SEATTLE, WA. FILED 11-16-2010.

**SECRET PLANT SOCIETY**

THE MARK CONSISTS OF STANDARD CHARACTERS WITHOUT CLAIM TO ANY PARTICULAR FONT, STYLE, SIZE, OR COLOR.

FOR DOWNLOADABLE ELECTRONIC GAME PROGRAMS AND SOFTWARE (U.S. CLS. 21, 23, 26, 36 AND 38).

MICHELE SWAIN, EXAMINING ATTORNEY

SN 85-178,477. SWING THE CIRCLE, LLC, SANTA ROSA, CA. FILED 11-16-2010.

**Swing The Circle**

THE MARK CONSISTS OF STANDARD CHARACTERS WITHOUT CLAIM TO ANY PARTICULAR FONT, STYLE, SIZE, OR COLOR.

FOR DVDS FEATURING GOLF INSTRUCTION (U.S. CLS. 21, 23, 26, 36 AND 38).

LINDA POWELL, EXAMINING ATTORNEY

**CLASS 9—(Continued).**

SN 85-178,521. ANOMAX CORPORATION LIMITED, PENANG, MALAYSIA, FILED 11-17-2010.

# IPCCHS

THE MARK CONSISTS OF STANDARD CHARACTERS WITHOUT CLAIM TO ANY PARTICULAR FONT, STYLE, SIZE, OR COLOR.

FOR HEAT SINKS FOR USE IN ELECTRONIC COMPONENTS (U.S. CLS. 21, 23, 26, 36 AND 38).  
BRENDAN REGAN, EXAMINING ATTORNEY

---

SN 85-178,563. NRS EVIR, LLC, BRIGHTON, CO. FILED 11-17-2010.

# EDVIR

THE MARK CONSISTS OF STANDARD CHARACTERS WITHOUT CLAIM TO ANY PARTICULAR FONT, STYLE, SIZE, OR COLOR.

FOR COMPUTER SOFTWARE USED TO MONITOR AND MANAGE COMMERCIAL VEHICLE SAFETY INSPECTIONS, REPAIRS, AND REPORTS OF SAFETY VIOLATIONS (U.S. CLS. 21, 23, 26, 36 AND 38).  
KIMBERLY PERRY, EXAMINING ATTORNEY

**CLASS 9—(Continued).**

SN 85-178,691. CHRYSALIS SOFTWARE CORPORATION, DIKE, TX. AND INFORMATION LLC, BOULDER, CO. FILED 11-17-2010.

# UltraDedup

THE MARK CONSISTS OF STANDARD CHARACTERS WITHOUT CLAIM TO ANY PARTICULAR FONT, STYLE, SIZE, OR COLOR.

FOR COMPUTER FIRMWARE FOR PERFORMING DATA DEDUPLICATION AND BACKUP AND RESTORE; COMPUTER OPERATING PROGRAMS; COMPUTER OPERATING PROGRAMS AND COMPUTER OPERATING SYSTEMS; COMPUTER PROGRAMS FOR SEARCHING REMOTELY FOR CONTENT ON COMPUTERS AND COMPUTER NETWORKS; COMPUTER PROGRAMS FOR SEARCHING THE CONTENTS OF COMPUTERS AND COMPUTER NETWORKS BY REMOTE CONTROL; COMPUTER PROGRAMS FOR PERFORMING DATA DEDUPLICATION AND BACKUP AND RESTORE; COMPUTER SOFTWARE AND HARDWARE FOR PERFORMING DATA DEDUPLICATION AND BACKUP AND RESTORE; COMPUTER SOFTWARE FOR USE IN THE ENCRYPTION AND DECRYPTION OF DIGITAL FILES, INCLUDING AUDIO, VIDEO, TEXT, BINARY, STILL IMAGES, GRAPHICS AND MULTIMEDIA FILES; COMPUTER SOFTWARE FOR PERFORMING DATA DEDUPLICATION AND BACKUP AND RESTORE; COMPUTER SOFTWARE TO MAINTAIN AND OPERATE COMPUTER SYSTEM; COMPUTER STORAGE DEVICES, NAMELY, HIGH-SPEED STORAGE SUBSYSTEMS FOR STORAGE AND BACKUP OF ELECTRONIC DATA EITHER LOCALLY OR VIA A TELECOMMUNICATIONS NETWORK; COMPUTER UTILITY PROGRAMS; COMPUTERS FOR USE IN DATA MANAGEMENT (U.S. CLS. 21, 23, 26, 36 AND 38).  
DOUGLAS LEE, EXAMINING ATTORNEY

---

SN 85-178,778. SOFTWARE FX, INC., BOCA RATON, FL. FILED 11-17-2010.

# 2WBUILDER

THE MARK CONSISTS OF STANDARD CHARACTERS WITHOUT CLAIM TO ANY PARTICULAR FONT, STYLE, SIZE, OR COLOR.

FOR COMPUTER SOFTWARE FOR DEVELOPMENT, DEPLOYMENT AND DELIVERY OF RICH DATA APPLICATIONS FOR TWO-WAY RADIOS (U.S. CLS. 21, 23, 26, 36 AND 38).  
KATHERINE STOIDES, EXAMINING ATTORNEY



**CLASS 9—(Continued).**

SN 85-178,794. ORANGE 21 NORTH AMERICA INC., CARLSBAD, CA. FILED 11-17-2010.

**CLASS 9—(Continued).**

SN 85-179,017. NEXTECH MATERIALS, LTD., LEWIS CENTER, OH. FILED 11-17-2010.

**TRON**

THE MARK CONSISTS OF STANDARD CHARACTERS WITHOUT CLAIM TO ANY PARTICULAR FONT, STYLE, SIZE, OR COLOR.  
FOR SUNGLASSES (U.S. CLS. 21, 23, 26, 36 AND 38).  
FIRST USE 1-11-2005; IN COMMERCE 3-31-2005.  
ROBERT C. CLARK JR., EXAMINING ATTORNEY

**NTM SenseH2**

THE MARK CONSISTS OF STANDARD CHARACTERS WITHOUT CLAIM TO ANY PARTICULAR FONT, STYLE, SIZE, OR COLOR.  
FOR HYDROGEN SENSING SYSTEMS COMPRISED OF HYDROGEN DETECTORS, SENSORS, AND MONITORS FOR COMMERCIAL, RESIDENTIAL, AUTOMOTIVE, AND INDUSTRIAL USE (U.S. CLS. 21, 23, 26, 36 AND 38).  
LINDA MICKLEBURGH, EXAMINING ATTORNEY

SN 85-178,905. DELTA TOUCH, LLC, CANOGA PARK, CA. FILED 11-17-2010.

**DELTATOUCH**

THE MARK CONSISTS OF STANDARD CHARACTERS WITHOUT CLAIM TO ANY PARTICULAR FONT, STYLE, SIZE, OR COLOR.  
FOR VIDEO MONITORS; COMPUTER MONITORS; TOUCH SCREEN AND TOUCH SENSITIVE VIDEO MONITORS (U.S. CLS. 21, 23, 26, 36 AND 38).  
FIRST USE 1-0-2006; IN COMMERCE 1-0-2006.  
DARRYL SPRUILL, EXAMINING ATTORNEY

SN 85-179,097. INCIPIO TECHNOLOGIES, INC., IRVINE, CA. FILED 11-17-2010.

SN 85-178,934. BEST DESIGNERS, INC., DORAL, FL. FILED 11-17-2010.

**SCRIPT**

**FLYWAY**

THE MARK CONSISTS OF STANDARD CHARACTERS WITHOUT CLAIM TO ANY PARTICULAR FONT, STYLE, SIZE, OR COLOR.  
FOR EYEGLASS FRAMES; EYEGLASS LENSES; EYEGLASSES (U.S. CLS. 21, 23, 26, 36 AND 38).  
FIRST USE 11-1-2010; IN COMMERCE 11-1-2010.  
ROBIN CHOSID, EXAMINING ATTORNEY

THE MARK CONSISTS OF STANDARD CHARACTERS WITHOUT CLAIM TO ANY PARTICULAR FONT, STYLE, SIZE, OR COLOR.  
FOR EARPHONES AND HEADPHONES (U.S. CLS. 21, 23, 26, 36 AND 38).  
LINDA MICKLEBURGH, EXAMINING ATTORNEY

**CLASS 9—(Continued).**

SN 85-179,098. MIGUEL S. GIACAMAN, SAN JOSE, CA.  
FILED 11-17-2010.

# PayGas

THE MARK CONSISTS OF STANDARD CHARACTERS WITHOUT CLAIM TO ANY PARTICULAR FONT, STYLE, SIZE, OR COLOR.

FOR AUTOMATED PROCESS CONTROL SYSTEM, NAMELY, MICRO-PROCESSOR BASED HARDWARE AND SOFTWARE USED TO MONITOR THE STATUS OF INDUSTRIAL PROCESSES, NAMELY, POWER GENERATION, ELECTRICAL DISTRIBUTION AND OIL AND GAS PROCESSING; CARD READERS FOR CREDIT CARDS; COMPUTER SOFTWARE FOR CONTROLLING SELF-SERVICE TERMINALS; COMPUTER SOFTWARE FOR WIRELESS CONTENT DELIVERY; COMPUTER TERMINALS; COMPUTER TERMINALS, KEYBOARDS AND PRINTERS; COMPUTER TOUCHSCREENS; COMPUTERS AND COMPUTER HARDWARE; COMPUTERS AND COMPUTER PERIPHERALS; CUSTOMER SELF SERVICE ELECTRONIC CHECKOUT STATION FOR POINT OF SALE; ELECTRONIC AND MAGNETIC ID CARDS FOR USE IN CONNECTION WITH PAYMENT FOR SERVICES; ELECTRONIC CONTROL SYSTEMS FOR MACHINES; ELECTRONIC EQUIPMENT FOR POINT-OF-SALES (POS) SYSTEMS, NAMELY, POINT-OF-SALE TERMINALS, BAR CODE READERS, OPTICAL READERS, ADVERTISEMENT DISPLAY MONITORS, KEYBOARDS, PRINTERS, SCANNERS, RADIO TRANSMITTERS, RADIO RECEIVERS, COMPUTER HARDWARE, AND COMPUTER OPERATING SOFTWARE; ELECTRONIC MACHINES FOR READING CREDIT CARDS AND RECORDING FINANCIAL OPERATIONS; ELECTRONIC MEMORY CARD READERS; ELECTRONIC PAYMENT TERMINAL; FUEL PUMPS FOR SERVICE STATIONS; METERED GASOLINE PUMPS; MOBILE DATA TERMINAL (MDT); MULTI-FUNCTIONAL COMPUTER TERMINALS WITH PAYMENT FUNCTION; MULTI-FUNCTIONAL ELECTRONIC PAYMENT TERMINALS; POINT-OF-SALE TERMINALS; SECURE TERMINALS FOR ELECTRONIC TRANSACTIONS; TELEPHONE TERMINAL; TELEPHONE TERMINALS (U.S. CLS. 21, 23, 26, 36 AND 38).  
LINDA MICKLEBURGH, EXAMINING ATTORNEY

SN 85-179,104. GIGA-BYTE TECHNOLOGY CO., LTD.,  
TAIPEI, TAIWAN, FILED 11-17-2010.

# G1-Commando

THE MARK CONSISTS OF STANDARD CHARACTERS WITHOUT CLAIM TO ANY PARTICULAR FONT, STYLE, SIZE, OR COLOR.

FOR MOTHERBOARDS (U.S. CLS. 21, 23, 26, 36 AND 38).  
BERYL GARDNER, EXAMINING ATTORNEY

**CLASS 9—(Continued).**

SN 85-179,117. GIGA-BYTE TECHNOLOGY CO., LTD.,  
TAIPEI, TAIWAN, FILED 11-17-2010.

# G1-Desperado

THE MARK CONSISTS OF STANDARD CHARACTERS WITHOUT CLAIM TO ANY PARTICULAR FONT, STYLE, SIZE, OR COLOR.

FOR MOTHERBOARDS (U.S. CLS. 21, 23, 26, 36 AND 38).  
BERYL GARDNER, EXAMINING ATTORNEY

SN 85-179,122. BOURGEOIS, ANDRE, REYNOLDSBURG,  
OH. FILED 11-17-2010.

# CARE-TALK

THE MARK CONSISTS OF STANDARD CHARACTERS WITHOUT CLAIM TO ANY PARTICULAR FONT, STYLE, SIZE, OR COLOR.

FOR WIRELESS COMMUNICATION DEVICES FOR VOICE, DATA OR IMAGE TRANSMISSION (U.S. CLS. 21, 23, 26, 36 AND 38).  
FIRST USE 11-0-2009; IN COMMERCE 11-0-2009.  
HEATHER BIDDULPH, EXAMINING ATTORNEY

SN 85-179,126. GIGA-BYTE TECHNOLOGY CO., LTD.,  
TAIPEI, TAIWAN, FILED 11-17-2010.

# G1-Outlaw

THE MARK CONSISTS OF STANDARD CHARACTERS WITHOUT CLAIM TO ANY PARTICULAR FONT, STYLE, SIZE, OR COLOR.

FOR MOTHERBOARDS (U.S. CLS. 21, 23, 26, 36 AND 38).  
BERYL GARDNER, EXAMINING ATTORNEY

**CLASS 9—(Continued).**

SN 85-179,129. GIGA-BYTE TECHNOLOGY CO., LTD.,  
TAIPEI, TAIWAN, FILED 11-17-2010.

# G1-Vigilante

THE MARK CONSISTS OF STANDARD CHARACTERS  
WITHOUT CLAIM TO ANY PARTICULAR FONT, STYLE,  
SIZE, OR COLOR.

FOR MOTHERBOARDS (U.S. CLS. 21, 23, 26, 36 AND  
38).

BERYL GARDNER, EXAMINING ATTORNEY

SN 85-179,167. JIHAD MOHAMED ALAWIE, CIUDAD DEL  
ESTE, PARAGUAY, FILED 11-17-2010.

# GIGATRONIC

THE MARK CONSISTS OF STANDARD CHARACTERS  
WITHOUT CLAIM TO ANY PARTICULAR FONT, STYLE,  
SIZE, OR COLOR.

FOR GLOBAL POSITIONING SYSTEM (GPS) CONSISTING OF COMPUTERS, COMPUTER SOFTWARE, TRANSMITTERS, RECEIVERS, AND NETWORK INTERFACE DEVICES; GPS NAVIGATION DEVICE; VEHICLE MOUNTED GPS SENSOR FOR DETERMINING THE RATE OF MOTION FOR A VEHICLE (U.S. CLS. 21, 23, 26, 36 AND 38).

FIRST USE 6-1-2010; IN COMMERCE 6-1-2010.  
MARC LEIPZIG, EXAMINING ATTORNEY

SN 85-179,372. TIMELINES, INC., CHICAGO, IL. FILED 11-17-2010.

# Photogram

THE MARK CONSISTS OF STANDARD CHARACTERS  
WITHOUT CLAIM TO ANY PARTICULAR FONT, STYLE,  
SIZE, OR COLOR.

FOR COMPUTER SOFTWARE FOR USE IN CAPTURING, ORGANIZING, SEARCHING, INDEXING, STORING, SYNCHRONIZING, RECOGNIZING, SHARING, TRANSMITTING AND DISPLAYING DIGITAL FILES, INCLUDING AUDIO, VIDEO, TEXT, BINARY, STILL IMAGES, GRAPHICS, DIGITAL CONTENT AND MULTIMEDIA FILES; DOWNLOADABLE COMPUTER SOFTWARE FOR USE IN CAPTURING, ORGANIZING, SEARCHING, INDEXING, STORING, SYNCHRONIZING, RECOGNIZING, SHARING AND TRANSMITTING DIGITAL FILES, INCLUDING AUDIO, VIDEO, TEXT, BINARY, STILL IMAGES, GRAPHICS, DIGITAL CONTENT, AND MULTIMEDIA FILES (U.S. CLS. 21, 23, 26, 36 AND 38).

DOMINIC J. FERRAIUOLO, EXAMINING ATTORNEY

**CLASS 9—(Continued).**

SN 85-179,465. PARSİ GROUP, INC., NORTH READING,  
MA. FILED 11-17-2010.

# PEXELL

THE MARK CONSISTS OF THE STYLIZED TEXT "PEXELL".

FOR BATTERIES AND BATTERY CHARGERS; CABLES, ELECTRIC; POWER ADAPTERS (U.S. CLS. 21, 23, 26, 36 AND 38).

FIRST USE 11-3-2006; IN COMMERCE 11-15-2006.  
KATINA MISTER, EXAMINING ATTORNEY

SN 85-179,599. ROBERT M. PLEAS, PUYALLUP, WA. FILED 11-18-2010.



THE MARK CONSISTS OF A LINE DRAWING OF A TRIPOD WITH A CAMERA PLACED ON THE TRIPOD HEAD.

FOR TRIPOD CAMERA MOUNTING HEAD (U.S. CLS. 21, 23, 26, 36 AND 38).

VIVIAN MICZNIK FIRST, EXAMINING ATTORNEY

SN 85-179,740. ANALOGIX SEMICONDUCTOR, INC., SANTA CLARA, CA. FILED 11-18-2010.

# SLIMPORT

THE MARK CONSISTS OF STANDARD CHARACTERS  
WITHOUT CLAIM TO ANY PARTICULAR FONT, STYLE,  
SIZE, OR COLOR.

FOR TRANSMITTERS OF ELECTRONIC SIGNALS; RECEIVERS OF ELECTRONIC SIGNALS (U.S. CLS. 21, 23, 26, 36 AND 38).

CHRISTINE MARTIN, EXAMINING ATTORNEY

**CLASS 9—(Continued).**

SN 85-179,857. BEST WESTERN INTERNATIONAL, INC., PHOENIX, AZ. FILED 11-18-2010.



OWNER OF U.S. REG. NOS. 1,900,620, 2,105,546 AND OTHERS.

THE MARK CONSISTS OF A CROWN DESIGN AND THE WORDS "BEST WESTERN" ON A FIVE-SIDED CURVILINEAR DESIGN WITH PIN STRIPING.

FOR COMPUTER APPLICATION SOFTWARE FOR MOBILE PHONES, NAMELY, SOFTWARE FOR LOCATING HOTELS, MAKING HOTEL RESERVATIONS, STORING AND ACCESSING IMAGES AND TRIP INFORMATION, AND TRANSMITTING IMAGES AND TRIP INFORMATION TO OTHERS (U.S. CLS. 21, 23, 26, 36 AND 38).

FIRST USE 7-1-2010; IN COMMERCE 7-1-2010.

REBECCA POVARCHUK, EXAMINING ATTORNEY

**CLASS 9—(Continued).**

SN 85-179,876. BEST WESTERN INTERNATIONAL, INC., PHOENIX, AZ. FILED 11-18-2010.

## BEST WESTERN

THE MARK CONSISTS OF STANDARD CHARACTERS WITHOUT CLAIM TO ANY PARTICULAR FONT, STYLE, SIZE, OR COLOR.

OWNER OF U.S. REG. NOS. 1,900,620, 2,105,546 AND OTHERS.

FOR COMPUTER APPLICATION SOFTWARE FOR MOBILE PHONES, NAMELY, SOFTWARE FOR LOCATING HOTELS, MAKING HOTEL RESERVATIONS, STORING AND ACCESSING IMAGES AND TRIP INFORMATION, AND TRANSMITTING IMAGES AND TRIP INFORMATION TO OTHERS (U.S. CLS. 21, 23, 26, 36 AND 38).

FIRST USE 7-1-2010; IN COMMERCE 7-1-2010.

REBECCA POVARCHUK, EXAMINING ATTORNEY

SN 85-179,868. BEST WESTERN INTERNATIONAL, INC., PHOENIX, AZ. FILED 11-18-2010.



OWNER OF U.S. REG. NOS. 1,900,620, 2,105,546 AND OTHERS.

THE COLOR(S) RED, YELLOW, AND BLUE IS/ARE CLAIMED AS A FEATURE OF THE MARK.

THE MARK CONSISTS OF A RED CROWN DESIGN AND THE WORDS "BEST WESTERN" IN YELLOW ON A FIVE-SIDED BLUE CURVILINEAR DESIGN WITH YELLOW PIN STRIPING.

FOR COMPUTER APPLICATION SOFTWARE FOR MOBILE PHONES, NAMELY, SOFTWARE FOR LOCATING HOTELS, MAKING HOTEL RESERVATIONS, STORING AND ACCESSING IMAGES AND TRIP INFORMATION, AND TRANSMITTING IMAGES AND TRIP INFORMATION TO OTHERS (U.S. CLS. 21, 23, 26, 36 AND 38).

FIRST USE 7-1-2010; IN COMMERCE 7-1-2010.

REBECCA POVARCHUK, EXAMINING ATTORNEY

SN 85-179,881. TIMELINES, INC., CHICAGO, IL. FILED 11-18-2010.

## Videogram

THE MARK CONSISTS OF STANDARD CHARACTERS WITHOUT CLAIM TO ANY PARTICULAR FONT, STYLE, SIZE, OR COLOR.

FOR COMPUTER SOFTWARE FOR USE IN CAPTURING, ORGANIZING, SEARCHING, INDEXING, STORING, SYNCHRONIZING, RECOGNIZING, SHARING, TRANSMITTING AND DISPLAYING DIGITAL FILES, INCLUDING AUDIO, VIDEO, TEXT, BINARY, STILL IMAGES, GRAPHICS, DIGITAL CONTENT AND MULTIMEDIA FILES; DOWNLOADABLE COMPUTER SOFTWARE FOR USE IN CAPTURING, ORGANIZING, SEARCHING, INDEXING, STORING, SYNCHRONIZING, RECOGNIZING, SHARING AND TRANSMITTING DIGITAL FILES, INCLUDING AUDIO, VIDEO, TEXT, BINARY, STILL IMAGES, GRAPHICS, DIGITAL CONTENT, AND MULTIMEDIA FILES (U.S. CLS. 21, 23, 26, 36 AND 38).

DOMINIC J. FERRAIUOLO, EXAMINING ATTORNEY

**CLASS 9—(Continued).**

SN 85-179,927. PRECO ELECTRONICS, INC., BOISE, ID.  
FILED 11-18-2010.

**CIRCLECHECK**

THE MARK CONSISTS OF STANDARD CHARACTERS WITHOUT CLAIM TO ANY PARTICULAR FONT, STYLE, SIZE, OR COLOR.

FOR RADAR OBJECT DETECTION SYSTEMS, NAMELY, VEHICLE-MOUNTED RADAR DETECTOR AND ALARM FOR OBJECTS SURROUNDING THE VEHICLE INCLUDING ANY ZONES OBSCURED FROM THE OPERATOR'S VIEW (U.S. CLS. 21, 23, 26, 36 AND 38).

JOHN E. MICHOS, EXAMINING ATTORNEY

**CLASS 9—(Continued).**

SN 85-180,317. SIMPLEX TIME RECORDER COMPANY INC., TORONTO, ONTARIO, CANADA, FILED 11-18-2010.

**PAYBAY**

THE MARK CONSISTS OF STANDARD CHARACTERS WITHOUT CLAIM TO ANY PARTICULAR FONT, STYLE, SIZE, OR COLOR.

FOR COMPUTER SOFTWARE AND HARDWARE FOR EMPLOYEE TIME AND ATTENDANCE RECORDING (U.S. CLS. 21, 23, 26, 36 AND 38).

FIRST USE 10-0-2010; IN COMMERCE 10-0-2010.

MARGERY A. TIERNEY, EXAMINING ATTORNEY

SN 85-180,301. 1. GE TRANSPORTATION SYSTEMS GLOBAL SIGNALING, LLC, GRAIN VALLEY, MO. FILED 11-18-2010.

**MYRAILYARD**

THE MARK CONSISTS OF STANDARD CHARACTERS WITHOUT CLAIM TO ANY PARTICULAR FONT, STYLE, SIZE, OR COLOR.

FOR COMPUTER SOFTWARE FOR INTERFACING AND INTERACTING WITH REMOTE CONTROL LOCOMOTIVES AND LOCOMOTIVE HARDWARE (U.S. CLS. 21, 23, 26, 36 AND 38).

MARGERY A. TIERNEY, EXAMINING ATTORNEY

SN 85-180,383. MLA MULTIBRAND HOLDINGS, INC., VERNON, CA. FILED 11-18-2010.

**TWELVE TWO**

THE MARK CONSISTS OF STANDARD CHARACTERS WITHOUT CLAIM TO ANY PARTICULAR FONT, STYLE, SIZE, OR COLOR.

FOR EYEWEAR AND SUNGLASSES (U.S. CLS. 21, 23, 26, 36 AND 38).

LAURA KOVALSKY, EXAMINING ATTORNEY

SN 85-180,309. PENNWELL CORPORATION, TULSA, OK. FILED 11-18-2010.

**OIL & GAS JOURNAL**

THE MARK CONSISTS OF STANDARD CHARACTERS WITHOUT CLAIM TO ANY PARTICULAR FONT, STYLE, SIZE, OR COLOR.

OWNER OF U.S. REG. NOS. 508,769, 3,720,687 AND OTHERS.

NO CLAIM IS MADE TO THE EXCLUSIVE RIGHT TO USE "JOURNAL", APART FROM THE MARK AS SHOWN. SEC. 2(F).

FOR DOWNLOADABLE ELECTRONIC MAGAZINE IN THE FIELD OF OIL AND GAS (U.S. CLS. 21, 23, 26, 36 AND 38).

FIRST USE 7-14-2003; IN COMMERCE 7-14-2003.

ELISSA GARBER KON, EXAMINING ATTORNEY

SN 85-180,434. DAVID RAMSEY, SAN FRANCISCO, CA. FILED 11-18-2010.

**APPOINTBOOK**

THE MARK CONSISTS OF STANDARD CHARACTERS WITHOUT CLAIM TO ANY PARTICULAR FONT, STYLE, SIZE, OR COLOR.

FOR COMPUTER APPLICATION SOFTWARE FOR MOBILE PHONES, NAMELY, SOFTWARE FOR USERS TO SEARCH AND MANAGE PERSONAL AND PROFESSIONAL SCHEDULING, MARKETING, PROMOTIONS, AND CLIENTS ONLINE FROM THEIR MOBILE PHONES; COMPUTER APPLICATION SOFTWARE FOR COMPUTERS, NAMELY, SOFTWARE FOR USERS TO SEARCH AND MANAGE PERSONAL AND PROFESSIONAL SCHEDULING, MARKETING, PROMOTIONS, AND CLIENTS ONLINE FROM THEIR COMPUTERS (U.S. CLS. 21, 23, 26, 36 AND 38).

JAY FLOWERS, EXAMINING ATTORNEY

**CLASS 9—(Continued).**

SN 85-180,499. MLA MULTIBRAND HOLDINGS, INC.,  
VERNON, CA. FILED 11-18-2010.

# 12-2

THE MARK CONSISTS OF STANDARD CHARACTERS  
WITHOUT CLAIM TO ANY PARTICULAR FONT, STYLE,  
SIZE, OR COLOR.

FOR EYEWEAR AND SUNGLASSES (U.S. CLS. 21, 23,  
26, 36 AND 38).

LAURA KOVALSKY, EXAMINING ATTORNEY

---

SN 85-181,040. THINGWORX, LLC, DOWNINGTOWN, PA.  
FILED 11-19-2010.

# THINGWORX

THE MARK CONSISTS OF STANDARD CHARACTERS  
WITHOUT CLAIM TO ANY PARTICULAR FONT, STYLE,  
SIZE, OR COLOR.

FOR SOFTWARE APPLICATION PLATFORM FOR  
CONNECTING PEOPLE, SERVICES AND DEVICES TO  
THE INTERNET (U.S. CLS. 21, 23, 26, 36 AND 38).

MIDGE BUTLER, EXAMINING ATTORNEY

---

SN 85-181,305. EMERALD MUSE INC., ULSTER PARK, NY.  
FILED 11-19-2010.

# PUNDORA'S PUN'KIN PATCH

THE MARK CONSISTS OF STANDARD CHARACTERS  
WITHOUT CLAIM TO ANY PARTICULAR FONT, STYLE,  
SIZE, OR COLOR.

FOR COMPUTER GAME SOFTWARE FOR USE ON  
MOBILE AND CELLULAR PHONES (U.S. CLS. 21, 23, 26,  
36 AND 38).

MELISSA VALLILLO, EXAMINING ATTORNEY

**CLASS 9—(Continued).**

SN 85-181,326. SOUTHERN TIRE SERVICES, INC., RIVER  
RIDGE, LA. FILED 11-19-2010.

# WHEELWARE

THE MARK CONSISTS OF STANDARD CHARACTERS  
WITHOUT CLAIM TO ANY PARTICULAR FONT, STYLE,  
SIZE, OR COLOR.

FOR COMPUTER SALES APPLICATION SOFTWARE  
FOR USE IN THE FIELD OF AUTOMOTIVE WHICH  
ALLOWS A CUSTOMER TO SELECT AND VIEW A  
VARIETY OF AUTOMOTIVE ACCESSORIES ON A  
SELECTED MAKE AND MODEL AUTOMOBILE (U.S.  
CLS. 21, 23, 26, 36 AND 38).

FIRST USE 1-11-2000; IN COMMERCE 1-11-2000.

SCOTT BIBB, EXAMINING ATTORNEY

---

SN 85-181,633. EXPRESSWELL INCORPORATED, NEW  
YORK, NY. FILED 11-19-2010.

# EXPRESSWELL

THE MARK CONSISTS OF STANDARD CHARACTERS  
WITHOUT CLAIM TO ANY PARTICULAR FONT, STYLE,  
SIZE, OR COLOR.

FOR COMPUTER SOFTWARE FOR THE COLLEC-  
TION, EDITING, ORGANIZING, MODIFYING, BOOK  
MARKING, TRANSMISSION, STORAGE AND SHARING  
OF DATA AND INFORMATION (U.S. CLS. 21, 23, 26, 36  
AND 38).

FIRST USE 2-17-2009; IN COMMERCE 2-11-2010.

PAUL F. GAST, EXAMINING ATTORNEY

---

SN 85-182,628. WISDOM AUDIO, CARSON CITY, NV. FILED  
11-22-2010.

# INSIGHT

THE MARK CONSISTS OF STANDARD CHARACTERS  
WITHOUT CLAIM TO ANY PARTICULAR FONT, STYLE,  
SIZE, OR COLOR.

FOR AUDIO SPEAKERS (U.S. CLS. 21, 23, 26, 36 AND  
38).

RONALD MCMORROW, EXAMINING ATTORNEY

**CLASS 9—(Continued).**

SN 85-182,662. COYODA INC, ALAMEDA, CA. FILED 11-22-2010.

NotesHive

THE MARK CONSISTS OF STANDARD CHARACTERS WITHOUT CLAIM TO ANY PARTICULAR FONT, STYLE, SIZE, OR COLOR.

FOR COMMUNICATION SOFTWARE FOR PROVIDING ACCESS TO THE INTERNET; COMPUTER APPLICATION SOFTWARE FOR MOBILE PHONES, NAMELY, SOFTWARE FOR CLOUD-BASED INFORMATION MANAGEMENT AND DATA EXCHANGE; COMPUTER APPLICATION SOFTWARE FOR PCS, MOBILE PHONE AND TABLETS, NAMELY, SOFTWARE FOR CLOUD-BASED INFORMATION MANAGEMENT AND DATA EXCHANGE; COMPUTER SOFTWARE FOR APPLICATION AND DATABASE INTEGRATION; COMPUTER SOFTWARE FOR COMMUNICATING WITH USERS OF HAND-HELD COMPUTERS; COMPUTER SOFTWARE FOR USE IN THE ENCRYPTION AND DECRYPTION OF DIGITAL FILES, INCLUDING AUDIO, VIDEO, TEXT, BINARY, STILL IMAGES, GRAPHICS AND MULTIMEDIA FILES; COMPUTER SOFTWARE FOR USE IN THE SAFEGUARDING OF DIGITAL FILES, INCLUDING AUDIO, VIDEO, TEXT, BINARY, STILL IMAGES, GRAPHICS AND MULTIMEDIA FILES (U.S. CLS. 21, 23, 26, 36 AND 38).

LAURIE KAUFMAN, EXAMINING ATTORNEY

**CLASS 9—(Continued).**

SN 85-183,686. NGMOCO, LLC, SAN FRANCISCO, CA. FILED 11-23-2010.

FANTASTIC FISH

THE MARK CONSISTS OF STANDARD CHARACTERS WITHOUT CLAIM TO ANY PARTICULAR FONT, STYLE, SIZE, OR COLOR.

FOR COMPUTER GAME SOFTWARE FOR MOBILE PHONES, MOBILE DEVICES, AND HANDHELD ELECTRONIC DEVICES; COMPUTER GAME PROGRAMS; COMPUTER GAME SOFTWARE (U.S. CLS. 21, 23, 26, 36 AND 38).

ALYSSA STEEL, EXAMINING ATTORNEY

SN 85-183,966. APPLIED GLOBAL TECHNOLOGIES, INC., ROCKLEDGE, FL. FILED 11-23-2010.

NEXUS<sup>c</sup>/R

THE MARK CONSISTS OF STANDARD CHARACTERS WITHOUT CLAIM TO ANY PARTICULAR FONT, STYLE, SIZE, OR COLOR.

OWNER OF U.S. REG. NO. 3,111,416. FOR COMPUTER HARDWARE AND SOFTWARE USED FOR LINKING RADIOS AND OTHER MOBILE DEVICES WITH VIDEO OR AUDIO CONFERENCES (U.S. CLS. 21, 23, 26, 36 AND 38).

FRANK LATTUCA, EXAMINING ATTORNEY

SN 85-183,484. JERRY HARVEY AUDIO, LLC, DBA JH AUDIO, APOPKA, FL. FILED 11-23-2010.

JH AUDIO

THE MARK CONSISTS OF STANDARD CHARACTERS WITHOUT CLAIM TO ANY PARTICULAR FONT, STYLE, SIZE, OR COLOR.

NO CLAIM IS MADE TO THE EXCLUSIVE RIGHT TO USE "AUDIO", APART FROM THE MARK AS SHOWN.

FOR EARPHONES, HEADPHONES, HEADSETS, SPEAKERS, AMPLIFIERS, CABLES FOR USE WITH EARPHONES, HEADPHONES, HEADSETS, AMPLIFIERS AND SPEAKERS (U.S. CLS. 21, 23, 26, 36 AND 38).

FIRST USE 10-0-2007; IN COMMERCE 10-0-2007. KATHERINE STOIDES, EXAMINING ATTORNEY

SN 85-186,729. INCIPIO TECHNOLOGIES, INC., IRVINE, CA. FILED 11-29-2010.

bigshow

THE MARK CONSISTS OF STANDARD CHARACTERS WITHOUT CLAIM TO ANY PARTICULAR FONT, STYLE, SIZE, OR COLOR.

FOR ELECTRONIC EQUIPMENT, NAMELY, TRANSFORMERS, BALUNS, CABLES USED IN CONNECTION WITH COMPUTERS, COMPUTER PERIPHERAL DEVICES, TELEVISIONS, AUDIO-VIDEO EQUIPMENT, CLOSED-CIRCUIT TV EQUIPMENT AND TELECOMMUNICATION EQUIPMENT (U.S. CLS. 21, 23, 26, 36 AND 38).

LINDA MICKLEBURGH, EXAMINING ATTORNEY

**CLASS 9—(Continued).**

SN 85-186,767. INCIPIO TECHNOLOGIES, INC., IRVINE, CA.  
FILED 11-29-2010.

# bombproof

THE MARK CONSISTS OF STANDARD CHARACTERS WITHOUT CLAIM TO ANY PARTICULAR FONT, STYLE, SIZE, OR COLOR.

FOR PROTECTIVE COVERS AND CASES FOR CELL PHONES, LAPTOPS AND PORTABLE MEDIA PLAYERS (U.S. CLS. 21, 23, 26, 36 AND 38).

FIRST USE 10-20-2010; IN COMMERCE 10-20-2010.  
LINDA MICKLEBURGH, EXAMINING ATTORNEY

**CLASS 9—(Continued).**

SN 85-188,681. GRAND VISION GAMING, LLC, BILLINGS, MT. FILED 12-1-2010.

# ULTRA VISION

THE MARK CONSISTS OF STANDARD CHARACTERS WITHOUT CLAIM TO ANY PARTICULAR FONT, STYLE, SIZE, OR COLOR.

FOR GAMING MACHINES (U.S. CLS. 21, 23, 26, 36 AND 38).

ANDREA BUTLER, EXAMINING ATTORNEY

SN 85-187,108. JANSPOUT APPAREL CORP., WILMINGTON, DE. FILED 11-30-2010.

# EASTPAK

THE MARK CONSISTS OF STANDARD CHARACTERS WITHOUT CLAIM TO ANY PARTICULAR FONT, STYLE, SIZE, OR COLOR.

OWNER OF U.S. REG. NOS. 1,524,386, 2,226,566 AND OTHERS.

FOR BACKPACKS, BAGS, BRIEFCASES, HAND BAGS, MESSENGER BAGS, SHOULDER BAGS, TOTE BAGS, WHEELED BACKPACKS, WHEELED MESSENGER BAGS, AND WHEELED BRIEFCASES, ALL SPECIFICALLY ADAPTED TO CARRY LAPTOPS, NOTEBOOK COMPUTERS, AND PERSONAL ELECTRONIC DEVICES; PROTECTIVE SLEEVES FOR LAPTOPS, NOTEBOOK COMPUTERS AND PERSONAL ELECTRONIC DEVICES; ORGANIZER POUCHES FOR CARRYING COMPUTER CABLES, COMPUTER MICE AND PORTABLE KEYBOARDS FOR LAPTOPS, NOTEBOOK COMPUTERS, AND PERSONAL ELECTRONIC DEVICES (U.S. CLS. 21, 23, 26, 36 AND 38).

KEVIN DINALLO, EXAMINING ATTORNEY

SN 85-193,187. THE CARTOON NETWORK, INC., ATLANTA, GA. FILED 12-8-2010.

# NTSF: SD: SUV::

THE MARK CONSISTS OF STANDARD CHARACTERS WITHOUT CLAIM TO ANY PARTICULAR FONT, STYLE, SIZE, OR COLOR.

FOR DVDS FEATURING ENTERTAINMENT, NAMELY, ANIMATION, COMEDY, ACTION AND ADVENTURE FOR YOUNG ADULTS AND ADULTS; DOWNLOADABLE PRE-RECORDED VIDEO RECORDING FEATURING ANIMATION, COMEDY, ACTION AND ADVENTURE; DOWNLOADABLE MULTIMEDIA FILES CONTAINING TEXT AND GRAPHICS FEATURING ANIMATION, COMEDY, ACTION AND ADVENTURE (U.S. CLS. 21, 23, 26, 36 AND 38).

FRED CARL, EXAMINING ATTORNEY

SN 85-187,810. GRAND VISION GAMING, LLC, BILLINGS, MT. FILED 11-30-2010.

# LUCKY FAVORITES

THE MARK CONSISTS OF STANDARD CHARACTERS WITHOUT CLAIM TO ANY PARTICULAR FONT, STYLE, SIZE, OR COLOR.

FOR GAMING MACHINES (U.S. CLS. 21, 23, 26, 36 AND 38).

ANDREA BUTLER, EXAMINING ATTORNEY

SN 85-198,498. INCIPIO TECHNOLOGIES, INC., IRVINE, CA. FILED 12-15-2010.

# superfly

THE MARK CONSISTS OF STANDARD CHARACTERS WITHOUT CLAIM TO ANY PARTICULAR FONT, STYLE, SIZE, OR COLOR.

FOR PROTECTIVE COVERS AND CASES FOR CELL PHONES AND PORTABLE MEDIA PLAYERS (U.S. CLS. 21, 23, 26, 36 AND 38).

LINDA MICKLEBURGH, EXAMINING ATTORNEY



**CLASS 9—(Continued).**

SN 85-199,975. STITCH N GENIUS, INC., BEVERLY HILLS, CA. FILED 12-16-2010.

**EZCURLER**

THE MARK CONSISTS OF STANDARD CHARACTERS WITHOUT CLAIM TO ANY PARTICULAR FONT, STYLE, SIZE, OR COLOR.  
FOR ELECTRIC HAIR CURLERS; ELECTRIC HAIR CURLING IRONS (U.S. CLS. 21, 23, 26, 36 AND 38).  
TARA PATE, EXAMINING ATTORNEY

SN 85-200,125. NORTHERN NEW JERSEY CANCER ASSOCIATES, HACKENSACK, NJ. FILED 12-16-2010.



NO CLAIM IS MADE TO THE EXCLUSIVE RIGHT TO USE "CANCER OUTCOME TRACKING AND ANALYSIS", APART FROM THE MARK AS SHOWN.  
THE COLOR(S) NAVY BLUE AND LIGHT BLUE IS/ARE CLAIMED AS A FEATURE OF THE MARK.  
THE MARK CONSISTS OF THE LITERAL ELEMENT "COTA" IN NAVY BLUE FONT WITH A LIGHT BLUE ARROW SUPERIMPOSED OVER THE "T" AND "A" AND HAVING A TRAIL OF LIGHT BLUE DOTS SUPERIMPOSED OVER THE "O" AND CONNECTING TO THE TAIL OF THE ARROW, AND THE LITERAL ELEMENT "CANCER OUTCOME TRACKING AND ANALYSIS" IN NAVY BLUE FONT APPEARING BELOW "COTA".  
FOR COMPUTER SOFTWARE FOR USE BY CANCER TREATMENT AND MEDICAL RESEARCH CENTERS FOR USE IN TRACKING PATIENT ACTIVITY, DIAGNOSIS, TREATMENT, STAGING, OUTCOMES, AND OTHER PATIENT DATA (U.S. CLS. 21, 23, 26, 36 AND 38).  
THOMAS MANOR, EXAMINING ATTORNEY

**CLASS 9—(Continued).**

SN 85-200,895. OMRON CORPORATION, KYOTO-SHI, KYOTO, JAPAN, FILED 12-17-2010.

**Wnn**

THE MARK CONSISTS OF STANDARD CHARACTERS WITHOUT CLAIM TO ANY PARTICULAR FONT, STYLE, SIZE, OR COLOR.  
FOR COMPUTER PROGRAMS FOR LANGUAGE AND NUMERICAL CHARACTER TRANSLATION; COMPUTER SOFTWARE FOR LANGUAGE AND NUMERICAL CHARACTER TRANSLATION (U.S. CLS. 21, 23, 26, 36 AND 38).  
LAURIE MAYES, EXAMINING ATTORNEY

SN 85-201,399. GUITAR CENTER, INC., WESTLAKE VILLAGE, CA. FILED 12-19-2010.

**FAT MAN**

THE MARK CONSISTS OF STANDARD CHARACTERS WITHOUT CLAIM TO ANY PARTICULAR FONT, STYLE, SIZE, OR COLOR.  
FOR ELECTRIC CABLES FOR USE WITH GUITARS, MIXERS, PROAUDIO APPLICATIONS, RECORDING APPLICATIONS AND OTHER MUSICAL APPLICATIONS REQUIRING THE USE OF CABLES (U.S. CLS. 21, 23, 26, 36 AND 38).  
RON FAIRBANKS, EXAMINING ATTORNEY

SN 85-201,870. THE RETHINK GROUP, INC., CUMMING, GA. FILED 12-20-2010.

**252 BASICS**

THE MARK CONSISTS OF STANDARD CHARACTERS WITHOUT CLAIM TO ANY PARTICULAR FONT, STYLE, SIZE, OR COLOR.  
OWNER OF U.S. REG. NO. 2,915,544.  
FOR ELECTRONIC DOWNLOADABLE RELIGIOUS INSTRUCTIONAL AND TEACHING MATERIALS AND DRAMATIC AND NON-DRAMATIC PRE-RECORDED DVDS AND CDS, ALL IN THE FIELDS OF SPIRITUAL FORMATION AND PARENTING (U.S. CLS. 21, 23, 26, 36 AND 38).  
FIRST USE 6-18-2002; IN COMMERCE 6-18-2002.  
MARK SHINER, EXAMINING ATTORNEY

**CLASS 9—(Continued).**

SN 85-204,347. BALLY GAMING, INC., DBA BALLY TECHNOLOGIES, LAS VEGAS, NV. FILED 12-22-2010.

**MONEY MAYHEM**

THE MARK CONSISTS OF STANDARD CHARACTERS WITHOUT CLAIM TO ANY PARTICULAR FONT, STYLE, SIZE, OR COLOR.

FOR COMPUTER GAMING SOFTWARE, GAMING SOFTWARE THAT GENERATES OR DISPLAYS WAGER OUTCOMES OF GAMING MACHINES, DOWNLOADABLE COMPUTER GAME SOFTWARE FOR GAMING, GAMING MACHINES, NAMELY, DEVICES THAT ACCEPT A WAGER; SLOT MACHINES (U.S. CLS. 21, 23, 26, 36 AND 38).

ANDREW RHIM, EXAMINING ATTORNEY

**CLASS 9—(Continued).**

SN 85-205,544. HON HAI PRECISION INDUSTRY CO., LTD., TAIPEI HSIEN, TAIWAN, FILED 12-24-2010.



THE MARK CONSISTS OF IRREGULAR GEOMETRIC DESIGNS.

FOR COMPUTER CARRYING CASES; CASES FOR MOBILE PHONES; BAGS FOR CAMERAS AND PHOTOGRAPHIC EQUIPMENT; AND CARRYING CASES FOR PERSONAL DIGITAL ASSISTANTS (U.S. CLS. 21, 23, 26, 36 AND 38).

JACLYN KIDWELL WALKER, EXAMINING ATTORNEY

SN 85-209,568. BACKFLIP STUDIOS, INC., BOULDER, CO. FILED 1-3-2011.

**BUGANOIDS**

THE MARK CONSISTS OF STANDARD CHARACTERS WITHOUT CLAIM TO ANY PARTICULAR FONT, STYLE, SIZE, OR COLOR.

FOR COMPUTER SOFTWARE AND DOWNLOADABLE SOFTWARE IN THE FIELD OF GAMES FOR USE ON COMPUTERS AND MOBILE COMMUNICATIONS DEVICES (U.S. CLS. 21, 23, 26, 36 AND 38).

FIRST USE 9-16-2010; IN COMMERCE 9-16-2010.

BRENDAN REGAN, EXAMINING ATTORNEY

SN 85-204,367. BALLY GAMING, INC., DBA BALLY TECHNOLOGIES, LAS VEGAS, NV. FILED 12-22-2010.

**MONEY WORKS**

THE MARK CONSISTS OF STANDARD CHARACTERS WITHOUT CLAIM TO ANY PARTICULAR FONT, STYLE, SIZE, OR COLOR.

FOR COMPUTER GAMING SOFTWARE, GAMING SOFTWARE THAT GENERATES OR DISPLAYS WAGER OUTCOMES OF GAMING MACHINES, DOWNLOADABLE COMPUTER GAME SOFTWARE FOR GAMING, GAMING MACHINES, NAMELY, DEVICES THAT ACCEPT A WAGER; SLOT MACHINES (U.S. CLS. 21, 23, 26, 36 AND 38).

ANDREW RHIM, EXAMINING ATTORNEY

SN 85-211,183. LIVE NATION WORLDWIDE, INC., BEVERLY HILLS, CA. FILED 1-5-2011.

**ARTIST NATION**

THE MARK CONSISTS OF STANDARD CHARACTERS WITHOUT CLAIM TO ANY PARTICULAR FONT, STYLE, SIZE, OR COLOR.

FOR AUDIO AND VIDEO RECORDINGS FEATURING MUSIC; DOWNLOADABLE RINGTONES; HEADPHONES (U.S. CLS. 21, 23, 26, 36 AND 38).

RAUL CORDOVA, EXAMINING ATTORNEY

**CLASS 9—(Continued).**

SN 85-214,597. KABUSHIKI KAISHA SQUARE ENIX, TA SQUARE ENIX CO., LTD., TOKYO, JAPAN, FILED 1-11-2011.

**IMAGINARY RANGE**

THE MARK CONSISTS OF STANDARD CHARACTERS WITHOUT CLAIM TO ANY PARTICULAR FONT, STYLE, SIZE, OR COLOR.

FOR COMPUTER GAME SOFTWARE; VIDEO GAME SOFTWARE; SOUND RECORDINGS IN THE FORM OF OPTICAL DISCS, MAGNETIC DISCS AND SEMICONDUCTOR ROMS FEATURING MUSIC AND FICTIONAL STORIES; AUDIO VISUAL RECORDINGS IN THE FORM OF OPTICAL DISCS, MAGNETIC DISCS AND SEMICONDUCTOR ROMS FEATURING MUSIC AND ANIMATED FICTIONAL STORIES; PRERECORDED COMPACT DISCS FEATURING MUSIC; PRERECORDED VIDEO DISCS FEATURING MUSIC AND ANIMATED FICTIONAL STORIES; MOUSE PADS; STRAPS FOR CELLULAR PHONES; VIDEO GAME CONTROLLERS; DOWNLOADABLE MUSICAL SOUND RECORDINGS; DOWNLOADABLE RING TONES FOR MOBILE PHONES; DOWNLOADABLE WALLPAPER GRAPHICS FOR MOBILE PHONES; DOWNLOADABLE ELECTRONIC PUBLICATIONS IN THE NATURE OF MAGAZINES, JOURNALS AND NEWSLETTERS IN THE FIELD OF COMPUTER GAMES AND VIDEO GAMES (U.S. CLS. 21, 23, 26, 36 AND 38).  
HANNO RITTNER, EXAMINING ATTORNEY

SN 85-218,240. MVL RIGHTS LLC, MANHATTAN BEACH, CA. FILED 1-14-2011.

**ANT-MAN**

THE MARK CONSISTS OF STANDARD CHARACTERS WITHOUT CLAIM TO ANY PARTICULAR FONT, STYLE, SIZE, OR COLOR.

OWNER OF U.S. REG. NO. 3,097,958.  
FOR BICYCLE HELMETS; COMPUTER GAME CARTRIDGES; COMPUTER GAME DISCS; COMPUTER GAME PROGRAMS; COMPUTER GAME SOFTWARE; COMPUTER GAME SOFTWARE DOWNLOADABLE FROM A GLOBAL COMPUTER NETWORK; DOWNLOADABLE COMPUTER GAME PROGRAMS; DOWNLOADABLE COMPUTER GAME SOFTWARE VIA A GLOBAL COMPUTER NETWORK AND WIRELESS DEVICES; DOWNLOADABLE COMPUTER PROGRAMS FEATURING POSITIONABLE GAME PIECE FIGURES FOR USE IN THE FIELD OF COMPUTER GAMES; INTERACTIVE MULTIMEDIA COMPUTER GAME PROGRAM; INTERACTIVE VIDEO GAME PROGRAMS; INTERACTIVE VIDEO GAMES OF VIRTUAL REALITY COMPRISED OF COMPUTER HARDWARE FOR USE WITH AN EXTERNAL MONITOR AND SOFTWARE; PRE-RECORDED CDS, VIDEO TAPES, LASER DISKS AND DVDS FEATURING MUSIC AND/OR LIVE ACTION PROGRAMS OR MOTION PICTURES OR ANIMATED CARTOONS OR ANIMATED FEATURE LENGTH FILMS; SUNGLASSES; VIDEO GAME CARTRIDGES; VIDEO GAME DISCS; VIDEO GAME SOFTWARE (U.S. CLS. 21, 23, 26, 36 AND 38).  
ANDREW LEASER, EXAMINING ATTORNEY

**CLASS 9—(Continued).**

SN 85-223,645. MINE O'MINE, INC., WOODLAND HILLS, CA. FILED 1-21-2011.

**DUNKMAN**

THE MARK CONSISTS OF STANDARD CHARACTERS WITHOUT CLAIM TO ANY PARTICULAR FONT, STYLE, SIZE, OR COLOR.

OWNER OF U.S. REG. NO. 2,919,666.  
FOR CASES FOR EYEGLASSES AND SUNGLASSES; EYEWEAR; SUNGLASSES (U.S. CLS. 21, 23, 26, 36 AND 38).  
KRISTINA MORRIS, EXAMINING ATTORNEY

SN 85-226,098. MIAMI TRIBE OF OKLAHOMA BUSINESS DEVELOPMENT AUTHORITY, A TRIBAL ENTERPRISE OF THE MIAMI TRIBE OF OKLAHOMA, MIAMI, OK. FILED 1-25-2011.

**Flights of Fortune**

THE MARK CONSISTS OF STANDARD CHARACTERS WITHOUT CLAIM TO ANY PARTICULAR FONT, STYLE, SIZE, OR COLOR.

FOR GAMING MACHINES, NAMELY, BINGO-RELATED GAMES AND SLOT MACHINES (U.S. CLS. 21, 23, 26, 36 AND 38).  
KATHLEEN M. VANSTON, EXAMINING ATTORNEY

SN 85-226,104. MIAMI TRIBE OF OKLAHOMA BUSINESS DEVELOPMENT AUTHORITY, A TRIBAL ENTERPRISE OF THE MIAMI TRIBE OF OKLAHOMA, MIAMI, OK. FILED 1-25-2011.

**Sky's the Limit**

THE MARK CONSISTS OF STANDARD CHARACTERS WITHOUT CLAIM TO ANY PARTICULAR FONT, STYLE, SIZE, OR COLOR.

FOR GAMING MACHINES, NAMELY, BINGO-RELATED GAMES AND SLOT MACHINES (U.S. CLS. 21, 23, 26, 36 AND 38).  
KATHLEEN M. VANSTON, EXAMINING ATTORNEY

**CLASS 9—(Continued).**

SN 85-234,865. MIAMI TRIBE OF OKLAHOMA BUSINESS DEVELOPMENT AUTHORITY, A TRIBAL ENTERPRISE OF THE MIAMI TRIBE OF OKLAHOMA, MIAMI, OK. FILED 2-4-2011.

**SUGARPLUM FAIRIES**

THE MARK CONSISTS OF STANDARD CHARACTERS WITHOUT CLAIM TO ANY PARTICULAR FONT, STYLE, SIZE, OR COLOR.

FOR GAMING MACHINES, NAMELY, BINGO-RELATED GAMES AND SLOT MACHINES (U.S. CLS. 21, 23, 26, 36 AND 38).

KATHY DE JONGE, EXAMINING ATTORNEY

**CLASS 9—(Continued).**

SN 85-245,689. PANAMA JACK INTERNATIONAL, INC., ORLANDO, FL. FILED 2-18-2011.

**PANAMA JACK OUTFITTERS**

THE MARK CONSISTS OF STANDARD CHARACTERS WITHOUT CLAIM TO ANY PARTICULAR FONT, STYLE, SIZE, OR COLOR.

OWNER OF U.S. REG. NOS. 1,776,347, 2,802,253 AND OTHERS.

NO CLAIM IS MADE TO THE EXCLUSIVE RIGHT TO USE "OUTFITTERS", APART FROM THE MARK AS SHOWN.

THE NAME(S), PORTRAIT(S), AND/OR SIGNATURE(S) SHOWN IN THE MARK DOES NOT IDENTIFY A PARTICULAR LIVING INDIVIDUAL.

FOR SUNGLASSES, SUNGLASS CASES, EYEGLASSES, EYEGLASS FRAMES AND EYEGLASS ACCESSORIES NAMELY, CASES, CORDS AND NOSE PADS (U.S. CLS. 21, 23, 26, 36 AND 38).

AMY KERTGATE, EXAMINING ATTORNEY

SN 85-239,512. TWENTIETH CENTURY FOX FILM CORPORATION, LOS ANGELES, CA. FILED 2-10-2011.

**EXIT STRATEGY****CLASS 10—MEDICAL APPARATUS**

SN 77-344,621. DISCUS DENTAL, LLC, CULVER CITY, CA. FILED 12-5-2007.

**FLASHLITE MAGNA**

THE MARK CONSISTS OF STANDARD CHARACTERS WITHOUT CLAIM TO ANY PARTICULAR FONT, STYLE, SIZE, OR COLOR.

FOR PRE-RECORDED DVDS FEATURING DRAMA; PRE-RECORDED CDS FEATURING DRAMA AND MUSICAL PERFORMANCES; DOWNLOADABLE AUDIO AND VIDEO RECORDINGS FEATURING DRAMA; DOWNLOADABLE TELEVISION SHOWS AND VIDEO RECORDINGS FEATURING DRAMA; DOWNLOADABLE RING TONES, RING BACKS, GRAPHICS, WALLPAPER, GAMES AND MUSIC VIA A GLOBAL COMPUTER NETWORK AND WIRELESS DEVICES; COMPUTER SCREEN SAVER SOFTWARE; COMPUTER GAME AND VIDEO GAME SOFTWARE; MOUSEPADS; DECORATIVE MAGNETS (U.S. CLS. 21, 23, 26, 36 AND 38).

ALICIA COLLINS, EXAMINING ATTORNEY

THE MARK CONSISTS OF STANDARD CHARACTERS WITHOUT CLAIM TO ANY PARTICULAR FONT, STYLE, SIZE, OR COLOR.

SEC. 2(F) AS TO "FLASHLITE".

FOR DENTAL INSTRUMENTS AND TOOLS FOR DENTAL BLEACHING OR WHITENING, NAMELY, DENTAL CURING LIGHTS; CURING DENTAL BITE TRAYS; INTRA-ORAL DENTAL LIGHTS; AND POLYMERIZATION APPARATUS FOR DENTAL PURPOSES, NAMELY, DENTAL CURING LIGHTS (U.S. CLS. 26, 39 AND 44).

FIRST USE 2-0-2008; IN COMMERCE 2-0-2008.

EVLYN BRADLEY, EXAMINING ATTORNEY

**CLASS 10—(Continued).**

SN 77-426,939. PIXEL VELOCITY INCORPORATED, ANN ARBOR, MI. FILED 3-20-2008.

## DYNAMIC CONTRACTILITY IMAGING

THE MARK CONSISTS OF STANDARD CHARACTERS WITHOUT CLAIM TO ANY PARTICULAR FONT, STYLE, SIZE, OR COLOR.

NO CLAIM IS MADE TO THE EXCLUSIVE RIGHT TO USE "CONTRACTILITY IMAGING", APART FROM THE MARK AS SHOWN.

FOR MEDICAL ULTRASOUND APPARATUS (U.S. CLS. 26, 39 AND 44).  
SANDRA BUJA, EXAMINING ATTORNEY

---

SN 77-628,623. AHRAM BIOSYSTEMS, INC., SEOUL, REPUBLIC OF KOREA, FILED 12-8-2008.

## Ahram

THE MARK CONSISTS OF STANDARD CHARACTERS WITHOUT CLAIM TO ANY PARTICULAR FONT, STYLE, SIZE, OR COLOR.

OWNER OF REPUBLIC OF KOREA REG. NO. 40-0807868, DATED 12-2-2009, EXPIRES 12-2-2019.

THE ENGLISH TRANSLATION OF "AHRAM" IN THE MARK IS FULLY RIPENED STATE OF CHESTNUTS OR ACORNS; OR FULLY RIPENED CHESTNUTS OR ACORNS. FOR DROPPING PIPETTES FOR MEDICAL PURPOSES; CARTRIDGES, AND CAPILLARIES, NAMELY, CAPILLARY TUBES FOR SAMPLES FOR THE PURPOSE OF MEDICAL OR DIAGNOSTIC ANALYSES FOR DISEASES (U.S. CLS. 26, 39 AND 44).

CARYN GLASSER, EXAMINING ATTORNEY

---

SN 77-856,863. CARANDANG, KATHRYN ANN, DBA WALKZSTORE, GREENWOOD, IN. FILED 10-25-2009.

## ezWalker

THE MARK CONSISTS OF STANDARD CHARACTERS WITHOUT CLAIM TO ANY PARTICULAR FONT, STYLE, SIZE, OR COLOR.

FOR ORTHOTIC INSERTS FOR FOOTWEAR (U.S. CLS. 26, 39 AND 44).

FIRST USE 10-1-2008; IN COMMERCE 2-16-2009.  
STEPHANIE ALI, EXAMINING ATTORNEY

**CLASS 10—(Continued).**

SN 77-889,468. HOME AND HEALTH PRODUCTS LLC, DBA HOME AND HEALTH, GLEN BURNIE, MD. FILED 12-9-2009.

## Home & Health

THE MARK CONSISTS OF STANDARD CHARACTERS WITHOUT CLAIM TO ANY PARTICULAR FONT, STYLE, SIZE, OR COLOR.

FOR MANUALLY-OPERATED EXERCISE EQUIPMENT FOR PHYSICAL THERAPY PURPOSES (U.S. CLS. 26, 39 AND 44).

FIRST USE 12-1-2009; IN COMMERCE 12-1-2009.  
LEIGH LOWRY, EXAMINING ATTORNEY

---

SN 77-891,130. MEDIC.NRG. LTD., KIBBUTZ AFIKIM, ISRAEL, FILED 12-11-2009.

## LUMINRG

THE MARK CONSISTS OF STANDARD CHARACTERS WITHOUT CLAIM TO ANY PARTICULAR FONT, STYLE, SIZE, OR COLOR.

PRIORITY CLAIMED UNDER SEC. 44(D) ON ISRAEL APPLICATION NO. 221,903, FILED 6-25-2009, REG. NO. 221903, DATED 2-6-2011, EXPIRES 2-6-2021.

FOR DENTAL INSTRUMENTS, NAMELY, PICKS AND MIRRORS, WITH AND WITHOUT A BUILT-IN LIGHT FOR ILLUMINATING THE ORAL CAVITY (U.S. CLS. 26, 39 AND 44).

ALEXANDER L. POWERS, EXAMINING ATTORNEY

---

SN 77-894,341. HILL-ROM SARL, PARIS, FRANCE, FILED 12-16-2009.

## I-MMERSION

THE MARK CONSISTS OF STANDARD CHARACTERS WITHOUT CLAIM TO ANY PARTICULAR FONT, STYLE, SIZE, OR COLOR.

OWNER OF ERPN CMNTY TM OFC REG. NO. 008382459, DATED 6-23-2009, EXPIRES 6-23-2019.

FOR BEDS, MATTRESSES, PADS AND SUPPORT SURFACES, ALL BEING FOR MEDICAL AND/OR THERAPEUTIC PURPOSES; SENSOR DEVICES FOR ENABLING AUTOMATIC ADJUSTMENT OF A PATIENT SUPPORT APPARATUS, SOLD AS A UNIT (U.S. CLS. 26, 39 AND 44).

JACQUELINE A. LAVINE, EXAMINING ATTORNEY

**CLASS 10—(Continued).**

SN 77-894,415. CAUTION WEAR CORP., NASHUA, NH.  
FILED 12-16-2009.

# Classic

THE MARK CONSISTS OF STANDARD CHARACTERS WITHOUT CLAIM TO ANY PARTICULAR FONT, STYLE, SIZE, OR COLOR.

FOR MEDICAL DEVICE MALE LATEX CONDOM (U.S. CLS. 26, 39 AND 44).

FIRST USE 11-28-2010; IN COMMERCE 11-28-2010.  
CHARLOTTE CORWIN, EXAMINING ATTORNEY

**CLASS 10—(Continued).**

SN 77-958,614. NILIMEDIX LTD., TIRAT-CARMEL, ISRAEL,  
FILED 3-15-2010.

# SPRING

THE MARK CONSISTS OF STANDARD CHARACTERS WITHOUT CLAIM TO ANY PARTICULAR FONT, STYLE, SIZE, OR COLOR.

FOR MEDICAL DEVICES, NAMELY, INFUSION SETS COMPRISED OF INFUSION PUMPS, INFUSION PUMP CONTROLLERS, AND PARTS FOR USE THEREWITH, ALL FOR DOSAGE OF INSULIN, MEASURING OF BLOOD GLUCOSE LEVELS AND MONITORING OF INSULIN AND BLOOD GLUCOSE LEVELS; MEDICAL DEVICES, NAMELY, INSULIN PUMPS; MEDICAL DEVICES, NAMELY, CONTINUOUS SUBCUTANEOUS INSULIN INFUSION DEVICES; MEDICAL DEVICES, NAMELY, MEDICAL DEVICES FOR CONTINUOUS GLUCOSE MONITORING (CGM) AND GLUCOSE MONITORING (U.S. CLS. 26, 39 AND 44).

HEATHER THOMPSON, EXAMINING ATTORNEY

SN 77-920,081. DESTEFANO, ROBERT L., LODI, NJ. FILED  
1-26-2010.

# F.A.S.T. STICK

THE MARK CONSISTS OF STANDARD CHARACTERS WITHOUT CLAIM TO ANY PARTICULAR FONT, STYLE, SIZE, OR COLOR.

NO CLAIM IS MADE TO THE EXCLUSIVE RIGHT TO USE "STICK", APART FROM THE MARK AS SHOWN.

FOR PHYSICAL REHABILITATION AND THERAPY APPARATUS, NAMELY, AN ELONGATED ROD HAVING AT LEAST ONE BULBOUS PORTION FOR THE TREATMENT OF MUSCLES AND BODY TISSUES (U.S. CLS. 26, 39 AND 44).

TINA L. SNAPP, EXAMINING ATTORNEY

SN 79-085,599. SPINESAVE AG, EMBRACH, SWITZERLAND, FILED 6-25-2010.

# SpineSave

SN 77-937,221. ADAMS, REBECCA INEZ, DBA RAW HEALTH SYSTEMS, BIRMINGHAM, AL. FILED 2-16-2010.

# REAL WHIZZINATORXXX

THE MARK CONSISTS OF STANDARD CHARACTERS WITHOUT CLAIM TO ANY PARTICULAR FONT, STYLE, SIZE, OR COLOR.

FOR ADULT SEXUAL STIMULATION AIDS, NAMELY, ARTIFICIAL PENIS (U.S. CLS. 26, 39 AND 44).

ELIZABETH KAJUBI, EXAMINING ATTORNEY

THE MARK CONSISTS OF STANDARD CHARACTERS WITHOUT CLAIM TO ANY PARTICULAR FONT, STYLE, SIZE, OR COLOR.

PRIORITY DATE OF 1-14-2010 IS CLAIMED.

OWNER OF INTERNATIONAL REGISTRATION 1046442 DATED 6-25-2010, EXPIRES 6-25-2020.

FOR ORTHOPEDIC ARTICLES, NAMELY, IMPLANTS AND INSTRUMENTS FOR SPINE SURGERY (U.S. CLS. 26, 39 AND 44).

RENEE MCCRAY, EXAMINING ATTORNEY

**CLASS 10—(Continued).**

SN 79-088,679. ATOM MEDICAL CORPORATION, TOKYO 113-0033, JAPAN, FILED 9-6-2010.



OWNER OF INTERNATIONAL REGISTRATION 1054809 DATED 9-6-2010, EXPIRES 9-6-2020.

THE COLOR(S) BLUE, YELLOW, ORANGE, BLACK AND WHITE IS/ARE CLAIMED AS A FEATURE OF THE MARK.

THE MARK CONSISTS OF THE WORDING "SUNFLOWER" IN A BLUE STYLIZED FONT, WITH AN ORANGE, YELLOW, BLACK AND WHITE SUNFLOWER WITH A SMILING FACE TO THE LEFT OF THE WORDING, WITH A LIGHT BLUE STEM AND LEAVES THAT EXTEND FROM THE FLOWER AND CROSS THROUGH THE WORDING.

FOR MEDICAL APPARATUS AND INSTRUMENTS, NAMELY, INFANT INCUBATORS; WARMING DEVICE FOR STABILIZING INFANT BODY TEMPERATURE; INFUSION PUMPS FOR ADMINISTERING BENEFICIAL AGENTS INTO THE BODY; SYRINGE PUMPS FOR ADMINISTERING BENEFICIAL AGENTS INTO THE BODY; MEDICAL EXAMINATION TABLES; HOSPITAL BABY DELIVERY BEDS; ULTRASONIC NEBULIZERS FOR RESPIRATION THERAPY (U.S. CLS. 26, 39 AND 44).

JAMES MACFARLANE, EXAMINING ATTORNEY

**CLASS 10—(Continued).**

SN 85-010,698. NAVISENSE, PLANTATION, AR. FILED 4-9-2010.

# NaviSense

THE MARK CONSISTS OF STANDARD CHARACTERS WITHOUT CLAIM TO ANY PARTICULAR FONT, STYLE, SIZE, OR COLOR.

FOR MEDICAL DEVICES, NAMELY, SURGICAL INSTRUMENTS COMPRISED OF ELECTRONIC CIRCUITS, SENSORS, PROCESSORS AND OPERATION SOFTWARE FOR COLLECTING, PROCESSING, AND DISTRIBUTING POSITIONAL DATA AND ORIENTATION DATA GATHERED FROM SENSORS, FOR TRACKING SURGICAL INSTRUMENTS DURING SURGICAL PROCESSES IN THE FIELD OF ORTHOPEDICS (U.S. CLS. 26, 39 AND 44).

LINDA POWELL, EXAMINING ATTORNEY

SN 85-004,036. MEDRAD, INC., INDIANOLA, PA. FILED 4-1-2010.

## MARK 7 ARTERION

THE MARK CONSISTS OF STANDARD CHARACTERS WITHOUT CLAIM TO ANY PARTICULAR FONT, STYLE, SIZE, OR COLOR.

FOR MEDICAL INJECTOR FOR INJECTING CONTRAST MEDIA AND OTHER MEDICAL FLUIDS INTO PATIENTS AND SYRINGES FOR USE THEREWITH (U.S. CLS. 26, 39 AND 44).

LEIGH LOWRY, EXAMINING ATTORNEY



OWNER OF U.S. REG. NO. 1,138,297.

THE MARK CONSISTS OF THE LETTERS "PDS" IN A BOX NEXT TO DOTS AND A CURVED LINE.

FOR SYNTHETIC ABSORBABLE IMPLANT FOR SURGICAL SUPPORT IN NASAL SOFT TISSUE AND CARTILAGE RECONSTRUCTION (U.S. CLS. 26, 39 AND 44).

BARBARA GAYNOR, EXAMINING ATTORNEY

SN 85-009,188. KASSAB KUGHN ENDOVASCULAR DEVICES LLC, FARMINGTON, MI. FILED 4-8-2010.

## OSTIAL GPS

THE MARK CONSISTS OF STANDARD CHARACTERS WITHOUT CLAIM TO ANY PARTICULAR FONT, STYLE, SIZE, OR COLOR.

NO CLAIM IS MADE TO THE EXCLUSIVE RIGHT TO USE "OSTIAL", APART FROM THE MARK AS SHOWN.

FOR MEDICAL DEVICES, NAMELY, CATHETERS, CATHETER COVERS, COVERS FOR MEDICAL CATHETER TUBING, AND TUBING FOR USE WITH CATHETERS (U.S. CLS. 26, 39 AND 44).

TRACY CROSS, EXAMINING ATTORNEY

SN 85-017,731. OSTEOSPRING MEDICAL, INC., PALO ALTO, CA. FILED 4-19-2010.

## OSTEOSPRING

THE MARK CONSISTS OF STANDARD CHARACTERS WITHOUT CLAIM TO ANY PARTICULAR FONT, STYLE, SIZE, OR COLOR.

FOR MEDICAL APPARATUS, DEVICES AND INSTRUMENTS FOR USE IN ORTHOPEDIC SURGERY; SURGICAL INSTRUMENTS AND APPARATUS; ORTHOPEDIC DEVICES FOR DIAGNOSTIC AND THERAPEUTIC USE; ORTHOPEDIC JOINT IMPLANTS (U.S. CLS. 26, 39 AND 44).

MATTHEW EINSTEIN, EXAMINING ATTORNEY

**CLASS 10—(Continued).**

SN 85-017,733. OSTEOSPRING MEDICAL, INC., PALO ALTO, CA. FILED 4-19-2010.

# OSTEOSPRING

THE MARK CONSISTS OF THE TERM "OSTEOSPRING", WITH THE LETTER "S" REPRESENTED BY A SPRING DESIGN.

FOR MEDICAL APPARATUS, DEVICES AND INSTRUMENTS FOR USE IN ORTHOPEDIC SURGERY; SURGICAL INSTRUMENTS AND APPARATUS; ORTHOPEDIC DEVICES FOR DIAGNOSTIC AND THERAPEUTIC USE; ORTHOPEDIC JOINT IMPLANTS (U.S. CLS. 26, 39 AND 44).

MATTHEW EINSTEIN, EXAMINING ATTORNEY

**CLASS 10—(Continued).**

SN 85-098,898. KARL STORZ GMBH & CO. KG, TUTTLINGEN, FED REP GERMANY, FILED 8-3-2010.

# TROLL-E

THE MARK CONSISTS OF STANDARD CHARACTERS WITHOUT CLAIM TO ANY PARTICULAR FONT, STYLE, SIZE, OR COLOR.

OWNER OF FED REP GERMANY REG. NO. 302010007718, DATED 5-11-2010, EXPIRES 2-29-2020.

FOR SURGICAL AND MEDICAL APPARATUS FOR USE IN GENERAL AND ENDOSCOPIC SURGERY (U.S. CLS. 26, 39 AND 44).

HOWARD B. LEVINE, EXAMINING ATTORNEY

SN 85-018,586. PNEUMOTECTOR DEVELOPMENT, LLC, MOUNTAIN LAKES, NJ. FILED 4-20-2010.

# PNEUMOTECTOR

THE MARK CONSISTS OF STANDARD CHARACTERS WITHOUT CLAIM TO ANY PARTICULAR FONT, STYLE, SIZE, OR COLOR.

FOR MEDICAL INSTRUMENTS FOR USE IN NON-INVASIVE DETECTION OF ATMOSPHERIC ANOMALIES WITHIN THE BODY (U.S. CLS. 26, 39 AND 44).

GISELLE AGOSTO, EXAMINING ATTORNEY

SN 85-105,920. ORABRUSH, INC., SPRINGVILLE, UT. FILED 8-12-2010.



THE NAME(S), PORTRAIT(S), AND/OR SIGNATURE(S) SHOWN IN THE MARK IDENTIFIES DAVE ACKERMAN, WHOSE CONSENT(S) TO REGISTER IS MADE OF RECORD.

THE MARK CONSISTS OF A MAN DRESSED IN AN OVERSIZED TONGUE COSTUME.

FOR TONGUE SCRAPERS (U.S. CLS. 26, 39 AND 44).

MICHAEL TANNER, EXAMINING ATTORNEY

SN 85-054,833. ETHAN RUBY, COLD SPRING, NY. FILED 6-4-2010.

# wheel comfort

NO CLAIM IS MADE TO THE EXCLUSIVE RIGHT TO USE "COMFORT", APART FROM THE MARK AS SHOWN. THE MARK CONSISTS OF THE WORDS, "WHEEL COMFORT", INSIDE THE DESIGN OF A ROUND EDGED, SHADED RECTANGLE WITH THE FIRST "O" OF "COMFORT" APPEARING IN THE SHAPE OF A SHIP'S STEERING WHEEL.

FOR MEDICAL PRODUCTS, NAMELY, PERMANENT AND NON-PERMANENT PADDED FOOT RESTS AND PADDED FOOT PLATES FOR MEDICAL OR THERAPEUTIC PURPOSES (U.S. CLS. 26, 39 AND 44).

FIRST USE 5-22-2010; IN COMMERCE 5-22-2010.

BARBARA A. GOLD, EXAMINING ATTORNEY

SN 85-108,137. INFOPIA AMERICA, LLC, DBA INFOPIA USA, TITUSVILLE, FL. FILED 8-16-2010.

# SmartDiabetes

ProActive Health Solutions

NO CLAIM IS MADE TO THE EXCLUSIVE RIGHT TO USE "HEALTH SOLUTIONS", APART FROM THE MARK AS SHOWN.

THE MARK CONSISTS OF "SMART DIABETES" WITH



**CLASS 10—(Continued).**

FIVE PROGRESSIVELY SMALLER SPHERES ARCHING ABOVE THE WORD "SMART" BEGINNING ABOVE THE LETTER "S" IN "SMART" AND ENDING ABOVE THE LETTER "D" IN "DIABETES". FIVE PROGRESSIVELY LARGERS SPHERES APPEAR IN A CURVED LINE BELOW THE WORD "DIABETES" BEGINNING BENEATH THE LETTER "I" AND ENDING BENEATH THE LETTER "S". THE WORDING "PROACTIVE HEALTH SOLUTIONS" APPEARS BELOW THE WORD "SMART" AND THE LETTERS "DI" IN "DIABETES".

FOR BLOOD PRESSURE AND DIABETIC DIAGNOSTIC MEDICAL DEVICES; DEVICES FOR MEASURING BLOOD SUGAR FOR MEDICAL PURPOSES; DEVICES FOR MONITORING BLOOD GLUCOSE FOR MEDICAL PURPOSES; MEDICAL DIAGNOSTIC APPARATUS, ANALYTICAL APPARATUS FOR MEDICAL PURPOSES AND BLOOD PRESSURE MEASURING APPARATUS (U.S. CLS. 26, 39 AND 44).

FIRST USE 7-27-2010; IN COMMERCE 8-3-2010.  
JAMES LOVELACE, EXAMINING ATTORNEY

---

SN 85-111,173. KUB TECHNOLOGIES, INC., DBA KUBTEC, MILFORD, CT. FILED 8-19-2010.



THE COLOR(S) NAVY BLUE, GRAY, AND RED IS/ARE CLAIMED AS A FEATURE OF THE MARK.

THE MARK CONSISTS OF THREE OVERLAPPING DIAMOND SHAPES. THE FIRST TWO DIAMONDS ARE VARIOUS SHADES OF GRAY AND OVERLAP A THIRD DIAMOND THAT IS PARTIALLY NAVY BLUE. THE LETTERING "KUBTEC" IS LOWERCASE AND IN RED. CENTERED BELOW "KUBTEC" ARE THE WORDS "GOING BEYOND THE SURFACE" IN NAVY BLUE.

FOR X-RAY APPARATUS FOR MEDICAL USE (U.S. CLS. 26, 39 AND 44).

FIRST USE 1-25-2005; IN COMMERCE 10-5-2005.  
MICHELLE DUBOIS, EXAMINING ATTORNEY

---

SN 85-112,418. N.V. PERRICONE LLC, MERIDEN, CT. FILED 8-20-2010.

**THE PERRICONE METHOD**

THE MARK CONSISTS OF STANDARD CHARACTERS WITHOUT CLAIM TO ANY PARTICULAR FONT, STYLE, SIZE, OR COLOR.

OWNER OF U.S. REG. NOS. 2,952,811, 3,596,203 AND OTHERS.

NO CLAIM IS MADE TO THE EXCLUSIVE RIGHT TO USE "METHOD", APART FROM THE MARK AS SHOWN.

FOR ELECTRICAL SKIN AND MUSCLE TISSUE REJUVENATION EQUIPMENT, NAMELY AN ELECTRICAL MICROCURRENT GENERATOR AND PROBES FOR CONTACTING SKIN AND MUSCLE TISSUE (U.S. CLS. 26, 39 AND 44).

FRANK LATTUCA, EXAMINING ATTORNEY

**CLASS 10—(Continued).**

SN 85-112,877. LU LU SPORTS CORP., NAN TOU HSIEN, TAIWAN, FILED 8-21-2010.

LU LU

THE MARK CONSISTS OF STANDARD CHARACTERS WITHOUT CLAIM TO ANY PARTICULAR FONT, STYLE, SIZE, OR COLOR.

THE NAME DOES NOT IDENTIFY A PARTICULAR LIVING INDIVIDUAL.

FOR ABDOMINAL BELTS, BELTS FOR MEDICAL PURPOSES, ARCH SUPPORTS FOR BOOTS AND SHOES, BOOTS FOR MEDICAL PURPOSES, ORTHOPEDIC ARTICLES, NAMELY, ORTHOPEDIC BELTS, ORTHOPEDIC FOOTWEAR (SHOES), ORTHOPEDIC SOLES, PHYSICAL EXERCISE APPARATUS, FOR MEDICAL PURPOSES (U.S. CLS. 26, 39 AND 44).

FIRST USE 3-3-2010; IN COMMERCE 3-3-2010.  
JOHN E. MICHOS, EXAMINING ATTORNEY

---

SN 85-117,133. VICTORIA LYNN HONEYCUTT, PALM DESERT, CA. FILED 8-27-2010.

**Rhythmiques**

THE MARK CONSISTS OF STANDARD CHARACTERS WITHOUT CLAIM TO ANY PARTICULAR FONT, STYLE, SIZE, OR COLOR.

FOR COSMETIC APPARATUS, NAMELY, LIGHT BASED DEVICES PROVIDING MAINLY PULSED LIGHT FOR PERFORMING NON-ABLATIVE AESTHETIC SKIN TREATMENT PROCEDURES (U.S. CLS. 26, 39 AND 44).

FIRST USE 9-1-2006; IN COMMERCE 2-7-2007.  
KELLY BOULTON, EXAMINING ATTORNEY

---

SN 85-119,073. MATLOCK, CHERYLE, LOS ANGELES, CA. FILED 8-30-2010.

**Cane Cozy**

THE MARK CONSISTS OF STANDARD CHARACTERS WITHOUT CLAIM TO ANY PARTICULAR FONT, STYLE, SIZE, OR COLOR.

NO CLAIM IS MADE TO THE EXCLUSIVE RIGHT TO USE "CANE", APART FROM THE MARK AS SHOWN.

FOR CANES FOR MEDICAL PURPOSES (U.S. CLS. 26, 39 AND 44).

FIRST USE 7-1-2000; IN COMMERCE 2-22-2001.  
ALICIA COLLINS, EXAMINING ATTORNEY

**CLASS 10—(Continued).**

SN 85-122,854. IDEXX LABORATORIES, INC., WEST-BROOK, ME. FILED 9-3-2010.

**IDEXX IVISION CR**

THE MARK CONSISTS OF STANDARD CHARACTERS WITHOUT CLAIM TO ANY PARTICULAR FONT, STYLE, SIZE, OR COLOR.

FOR DIGITAL IMAGING SYSTEM COMPRISED OF DIGITAL IMAGING PLATES AND DIGITAL IMAGING PLATE READER USEFUL FOR READING AND DISPLAYING X-RAY IMAGES OF ANIMALS FOR VETERINARY PRACTICE (U.S. CLS. 26, 39 AND 44).

JACQUELINE A. LAVINE, EXAMINING ATTORNEY

SN 85-129,173. APPLIED MEDICAL RESOURCES CORPORATION, RANCHO SANTA MARGARITA, CA. FILED 9-14-2010.

**EPIX**

THE MARK CONSISTS OF STANDARD CHARACTERS WITHOUT CLAIM TO ANY PARTICULAR FONT, STYLE, SIZE, OR COLOR.

FOR MEDICAL AND SURGICAL DEVICES, NAMELY, LAPAROSCOPIC INSTRUMENTS (U.S. CLS. 26, 39 AND 44).

APRIL ROACH, EXAMINING ATTORNEY

SN 85-132,634. BEAM ASSOCIATES LLC, LYNDHURST, NJ. FILED 9-17-2010.

**IMED CORRECTION**

THE MARK CONSISTS OF STANDARD CHARACTERS WITHOUT CLAIM TO ANY PARTICULAR FONT, STYLE, SIZE, OR COLOR.

NO CLAIM IS MADE TO THE EXCLUSIVE RIGHT TO USE "CORRECTION", APART FROM THE MARK AS SHOWN.

FOR EXTERNAL FIXATION DEVICE AND SOFTWARE FOR USE IN ORTHOPEDIC CORRECTIVE PROCEDURES AND SOFTWARE SOLD AS A UNIT THEREWITH (U.S. CLS. 26, 39 AND 44).

FIRST USE 1-1-2010; IN COMMERCE 1-1-2010.

ARETHA SOMERVILLE, EXAMINING ATTORNEY

**CLASS 10—(Continued).**

SN 85-140,266. BIOLASE TECHNOLOGY, INC., IRVINE, CA. FILED 9-28-2010.

**ilase**

OWNER OF U.S. REG. NOS. 2,535,143, 3,454,749 AND OTHERS.

THE MARK CONSISTS OF ONE WORD "ILASE" ALL IN ITALICS, WITH THE "I" BEING LOWERCASE, THE "L" BEING CAPITALIZED, AND "ASE" BEING LOWERCASE.

FOR DENTAL INSTRUMENTS FOR USE IN ORAL AND JOINT THERAPEUTIC TREATMENT OF SKIN, NERVE AND MUSCLE TISSUES; DENTAL INSTRUMENTS, NAMELY, ORAL IRRIGATORS, DENTAL DEVICES FOR ROOT CANAL PROCEDURES IN THE NATURE OF ROOT CANAL THERAPY INSTRUMENTS USED TO SHAVE THE INSIDE OF A ROOT CANAL AND DENTAL ROOT FILES USED IN ROOT CANAL DENTAL PROCEDURES, DENTAL HAND PIECES, ELECTROMAGNETIC ENERGY EMITTING DEVICES FOR DENTAL AND MEDICAL USE IN THE NATURE OF LASERS FOR DENTAL AND MEDICAL USE AND STRUCTURAL COMPONENT PARTS THEREFOR; ELECTRONIC AESTHETIC SKIN TREATMENT DEVICES USING LIGHT EMITTING DIODES, NAMELY, INFRARED, RED, ORANGE, YELLOW, GREEN, AND BLUE WAVELENGTHS FOR GENERATING LIGHT RAYS; ELECTRONIC LIGHT THERAPY APPARATUS FOR THE SKIN; ELECTRONIC STIMULATOR FOR ORAL AND JOINT TREATMENT OF SKIN, NERVE AND MUSCLE TISSUES; LASERS FOR MEDICAL PURPOSES; LASERS FOR MEDICAL USE; LASERS FOR SURGICAL AND MEDICAL USE; LASERS FOR THE COSMETIC TREATMENT OF THE FACE AND SKIN; LIGHT EMITTING DEVICES, NAMELY, LAMPS AND LED DEVICES FOR TREATMENT OF A VARIETY OF SKIN CONDITIONS; LIGHT EMITTING DIODE (LED) APPARATUS FOR LIGHTING, INCORPORATED INTO MEDICAL INSTRUMENTS; MEDICAL AND SURGICAL LAPAROSCOPES; MEDICAL APPARATUS AND INSTRUMENTS FOR USE IN SURGERY (U.S. CLS. 26, 39 AND 44).

DAVID YONTEF, EXAMINING ATTORNEY

SN 85-144,905. SLEEP SPECIALISTS, LLC, PLYMOUTH MEETING, PA. FILED 10-5-2010.

The logo for 2zmedical features a stylized 'Z' symbol on the left, composed of two overlapping shapes: a dark blue shape on the left and a light blue shape on the right. To the right of the symbol, the text '2zmedical' is written in a sans-serif font, with '2z' in dark blue and 'medical' in light blue.

THE COLOR(S) DARK BLUE, LIGHT BLUE AND BLACK IS/ARE CLAIMED AS A FEATURE OF THE MARK.

THE MARK CONSISTS OF TWO ANGLED, VERTICAL, WAVY LINES COLORED DARK BLUE AND LIGHT BLUE, WITH THE PHRASE "2ZMEDICAL" IMMEDIATELY TO THE RIGHT THEREOF, THE NUMBER "2" IN DARK BLUE, THE LETTER "Z" IN LIGHT BLUE AND "MEDICAL" IN BLACK.

FOR A POSITIONAL SLEEP DEVICE WORN BY AN INDIVIDUAL COMPRISED OF FABRIC AND A RAISED CUSHION THAT IS WRAPPED AROUND ONE'S BACK TO PREVENT LYING ON THE BACK WHILE SLEEPING OR AT REST FOR THE PREVENTION OF SNORING AND SLEEP APNEA (U.S. CLS. 26, 39 AND 44).

FRED CARL, EXAMINING ATTORNEY

**CLASS 10—(Continued).**

SN 85-144,907. SLEEP SPECIALISTS, LLC, PLYMOUTH MEETING, PA. FILED 10-5-2010.

**CLASS 10—(Continued).**

SN 85-145,981. NOVARTIS AG, BASEL, SWITZERLAND, FILED 10-6-2010.

# 2ZMEDICAL



THE MARK CONSISTS OF STANDARD CHARACTERS WITHOUT CLAIM TO ANY PARTICULAR FONT, STYLE, SIZE, OR COLOR.

FOR A POSITIONAL SLEEP DEVICE WORN BY AN INDIVIDUAL COMPRISED OF FABRIC AND A RAISED CUSHION THAT IS WRAPPED AROUND ONE'S BACK TO PREVENT LYING ON THE BACK WHILE SLEEPING OR AT REST FOR THE PREVENTION OF SNORING AND SLEEP APNEA (U.S. CLS. 26, 39 AND 44).  
FRED CARL, EXAMINING ATTORNEY

NO CLAIM IS MADE TO THE EXCLUSIVE RIGHT TO USE "COMPREHENSIVE APPROACH", APART FROM THE MARK AS SHOWN.

THE MARK CONSISTS OF THE WORDING "THE COMPREHENSIVE APPROACH" AND DESIGN. THE DESIGN CONSISTS OF A SQUARE COMPOSED OF 16 SMALLER SQUARES AND TWO CONCENTRIC DIAMONDS. AN EIGHT POINT STAR APPEARS WITHIN THE SPACE BETWEEN THE TWO CONCENTRIC DIAMONDS THAT APPEAR IN THE LOWER RIGHT SECTION OF THE DESIGN. TO THE RIGHT OF THE DESIGN IS THE WORDING "THE COMPREHENSIVE APPROACH".

FOR INJECTION DEVICE FOR PHARMACEUTICALS; INJECTION INSTRUMENTS WITH NEEDLES; INJECTION INSTRUMENTS WITHOUT NEEDLES; INJECTION SYRINGES; MEDICAL APPARATUS, NAMELY, INFUSION AND INJECTION DEVICES FOR ADMINISTERING DRUGS (U.S. CLS. 26, 39 AND 44).  
MARLENE BELL, EXAMINING ATTORNEY

SN 85-144,908. SLEEP SPECIALISTS, LLC, PLYMOUTH MEETING, PA. FILED 10-5-2010.

SN 85-145,986. NOVARTIS AG, BASEL, SWITZERLAND, FILED 10-6-2010.

## IF IT DOESN'T HAVE 2ZS IT'S NOT ZZOMA



THE MARK CONSISTS OF STANDARD CHARACTERS WITHOUT CLAIM TO ANY PARTICULAR FONT, STYLE, SIZE, OR COLOR.

OWNER OF U.S. REG. NO. 3,642,232.  
FOR A POSITIONAL SLEEP DEVICE WORN BY AN INDIVIDUAL COMPRISED OF FABRIC AND A RAISED CUSHION THAT IS WRAPPED AROUND ONE'S BACK TO PREVENT LYING ON THE BACK WHILE SLEEPING OR AT REST FOR THE PREVENTION OF SNORING AND SLEEP APNEA (U.S. CLS. 26, 39 AND 44).  
FRED CARL, EXAMINING ATTORNEY

THE MARK CONSISTS OF A SQUARE COMPOSED OF 16 SMALLER SQUARES AND TWO CONCENTRIC DIAMONDS. AN EIGHT POINT STAR APPEARS WITHIN THE SPACE BETWEEN THE TWO CONCENTRIC DIAMONDS IN THE LOWER RIGHT SECTION OF THE DESIGN.

FOR INJECTION DEVICE FOR PHARMACEUTICALS; INJECTION INSTRUMENTS WITH NEEDLES; INJECTION INSTRUMENTS WITHOUT NEEDLES; INJECTION SYRINGES; MEDICAL APPARATUS, NAMELY, INFUSION AND INJECTION DEVICES FOR ADMINISTERING DRUGS (U.S. CLS. 26, 39 AND 44).  
MARLENE BELL, EXAMINING ATTORNEY

**CLASS 10—(Continued).**

SN 85-150,025. ACCESSCLOSURE, INC., MOUNTAIN VIEW, CA. FILED 10-11-2010.

MYNX VASCULAR CLOSURE  
DEVICE WITH GRIP TECHNOLOGY

THE MARK CONSISTS OF STANDARD CHARACTERS WITHOUT CLAIM TO ANY PARTICULAR FONT, STYLE, SIZE, OR COLOR.

OWNER OF U.S. REG. NO. 3,432,082.

NO CLAIM IS MADE TO THE EXCLUSIVE RIGHT TO USE "VASCULAR CLOSURE DEVICE", APART FROM THE MARK AS SHOWN.

FOR VASCULAR HEMOSTASIS DEVICES (U.S. CLS. 26, 39 AND 44).

LINDA MICKLEBURGH, EXAMINING ATTORNEY

**CLASS 10—(Continued).**

SN 85-151,723. THUMPER MASSAGER, INC., MARKHAM, ONTARIO, CANADA, FILED 10-13-2010.

MASSAGER WITH MUSCLE

THE MARK CONSISTS OF STANDARD CHARACTERS WITHOUT CLAIM TO ANY PARTICULAR FONT, STYLE, SIZE, OR COLOR.

NO CLAIM IS MADE TO THE EXCLUSIVE RIGHT TO USE "MASSAGER", APART FROM THE MARK AS SHOWN.

FOR MASSAGE APPARATUS (U.S. CLS. 26, 39 AND 44).

FIRST USE 9-30-1988; IN COMMERCE 1-31-1995.

GISELLE AGOSTO, EXAMINING ATTORNEY

SN 85-150,032. ACCESSCLOSURE, INC., MOUNTAIN VIEW, CA. FILED 10-11-2010.

MYNX WITH GRIP

THE MARK CONSISTS OF STANDARD CHARACTERS WITHOUT CLAIM TO ANY PARTICULAR FONT, STYLE, SIZE, OR COLOR.

OWNER OF U.S. REG. NO. 3,432,082.

FOR VASCULAR HEMOSTASIS DEVICES (U.S. CLS. 26, 39 AND 44).

LINDA MICKLEBURGH, EXAMINING ATTORNEY

SN 85-152,438. SENSUS HEALTHCARE LLC, BOCA RATON, FL. FILED 10-14-2010.

SENSUS HEALTHCARE

THE MARK CONSISTS OF STANDARD CHARACTERS WITHOUT CLAIM TO ANY PARTICULAR FONT, STYLE, SIZE, OR COLOR.

NO CLAIM IS MADE TO THE EXCLUSIVE RIGHT TO USE "HEALTHCARE", APART FROM THE MARK AS SHOWN.

FOR MEDICAL DEVICES USED IN THE TREATMENT OF SKIN CANCER AND OTHER CANCERS (U.S. CLS. 26, 39 AND 44).

ANDREW LEASER, EXAMINING ATTORNEY

SN 85-151,153. ONESTOP INC., TERRYVILLE, CT. FILED 10-13-2010.

Nano Diva

THE MARK CONSISTS OF STANDARD CHARACTERS WITHOUT CLAIM TO ANY PARTICULAR FONT, STYLE, SIZE, OR COLOR.

NO CLAIM IS MADE TO THE EXCLUSIVE RIGHT TO USE "NANO", APART FROM THE MARK AS SHOWN.

FOR ACUPUNCTURE EQUIPMENT; ACUPUNCTURE INSTRUMENTS; APPARATUS FOR ACUPUNCTURE THERAPY; DRUG DELIVERY SYSTEMS; MASSAGE APPARATUS; MASSAGE APPARATUS AND INSTRUMENTS; MASSAGING APPARATUS FOR PERSONAL USE; MEDICAL APPARATUS FOR INTRODUCING PHARMACEUTICAL PREPARATIONS INTO THE HUMAN BODY (U.S. CLS. 26, 39 AND 44).

FIRST USE 10-13-2010; IN COMMERCE 10-13-2010.

JANICE L. MCMORROW, EXAMINING ATTORNEY

SN 85-153,600. SASSY PACI BOUTIQUE, MIDDLETOWN, OH. FILED 10-15-2010.



NO CLAIM IS MADE TO THE EXCLUSIVE RIGHT TO USE "BOUTIQUE", APART FROM THE MARK AS SHOWN.

THE MARK CONSISTS OF THE STYLIZED WORDS "SASSY PACI BOUTIQUE". THE LETTER "S" IN THE WORD "SASSY" IS IN THE FORM OF A PACIFIER.

FOR PACIFIER CLIPS; PACIFIER HOLDERS (U.S. CLS. 26, 39 AND 44).

FIRST USE 1-1-2009; IN COMMERCE 1-1-2009.

PAUL F. GAST, EXAMINING ATTORNEY

**CLASS 10—(Continued).**

SN 85-153,689. JOINT REPLACEMENT INSTRUMENTATION LIMITED, LONDON, UNITED KINGDOM, FILED 10-15-2010.

**CLASS 10—(Continued).**

SN 85-153,762. JOINT REPLACEMENT INSTRUMENTATION LIMITED, LONDON, UNITED KINGDOM, FILED 10-15-2010.



PRIORITY CLAIMED UNDER SEC. 44(D) ON ERPN CMNTY TM OFC APPLICATION NO. 009035098, FILED 4-16-2010, REG. NO. 009035098, DATED 9-28-2010, EXPIRES 4-16-2020.

THE COLOR(S) BLUE AND WHITE IS/ARE CLAIMED AS A FEATURE OF THE MARK.

THE MARK CONSISTS OF AN "F" LOGO IN WHITE ON A BLUE CIRCLE AND AN OVAL CONTAINING SHADING OF DIFFERENT HUES OF BLUE WITHIN THE SAME BLUE CIRCLE.

FOR ORTHOPAEDIC IMPLANTS MADE FROM ARTIFICIAL MATERIAL; BONE, SHOULDER, KNEE, HIP, JOINT, LEG, FOOT, ARM AND HAND PROSTHESES; ORTHOPAEDIC IMPLANTS AND PROSTHESES; APPARATUS, ARTICLES AND INSTRUMENTS, ALL FOR ORTHOPAEDIC USE, NAMELY, ORTHOPAEDIC FIXATION DEVICES USED IN ORTHOPAEDIC TRANSPLANT OR IMPLANT SURGERY; SURGICAL INSTRUMENTS, NAMELY, DEVICES USED IN ORTHOPAEDIC SURGERY TO POSITION SURGICAL INSTRUMENTS, IMPLANTS AND/OR A PATIENT'S LIMBS; STEMS AND HEADS OF PROSTHESES; CUPS FOR PROSTHESES; STRUCTURAL PARTS AND FITTINGS FOR ALL THE AFORESAID GOODS; SCREWS FOR SECURING PROSTHESES; SYNTHETIC MATERIAL FOR SURGICAL USE FOR COATING ORTHOPAEDIC IMPLANTS AND PROSTHESES; MEDICAL DEVICES, NAMELY, SLEEVES OR THIMBLES OF COATING MATERIAL FOR POSITIONING OR ASSISTING BONE GROWTH TO SECURE PROSTHESES; SUTURE MATERIALS (U.S. CLS. 26, 39 AND 44).

SIMON TENG, EXAMINING ATTORNEY

PRIORITY CLAIMED UNDER SEC. 44(D) ON ERPN CMNTY TM OFC APPLICATION NO. 009035122, FILED 4-16-2010, REG. NO. 009035122, DATED 9-14-2010, EXPIRES 4-16-2020.

THE COLOR(S) BLUE IS/ARE CLAIMED AS A FEATURE OF THE MARK.

THE MARK CONSISTS OF LOWERCASE STYLIZED LETTERS "JRI" CONTAINING SHADING OF DIFFERENT HUES OF BLUE. THE DOT OVER THE LETTER "I" IS A BLUE CIRCLE. WITHIN THE BLUE CIRCLE IS AN OVAL WHICH ALSO CONTAINS SHADING OF DIFFERENT HUES OF BLUE.

FOR ORTHOPAEDIC IMPLANTS MADE FROM ARTIFICIAL MATERIAL; BONE, SHOULDER, KNEE, HIP, JOINT, LEG, FOOT, ARM AND HAND PROSTHESES; ORTHOPAEDIC IMPLANTS AND PROSTHESES; APPARATUS, ARTICLES AND INSTRUMENTS, ALL FOR ORTHOPAEDIC USE, NAMELY, ORTHOPAEDIC FIXATION DEVICES USED IN ORTHOPAEDIC TRANSPLANT OR IMPLANT SURGERY; SURGICAL INSTRUMENTS, NAMELY, DEVICES USED IN ORTHOPAEDIC SURGERY TO POSITION SURGICAL INSTRUMENTS, IMPLANTS AND/OR A PATIENT'S LIMBS; STEMS AND HEADS OF PROSTHESES; CUPS FOR PROSTHESES; STRUCTURAL PARTS AND FITTINGS FOR ALL THE AFORESAID GOODS; SCREWS FOR SECURING PROSTHESES; SYNTHETIC MATERIAL FOR SURGICAL USE FOR COATING ORTHOPAEDIC IMPLANTS AND PROSTHESES; MEDICAL DEVICES, NAMELY, SLEEVES OR THIMBLES OF COATING MATERIAL FOR POSITIONING OR ASSISTING BONE GROWTH TO SECURE PROSTHESES; SUTURE MATERIALS (U.S. CLS. 26, 39 AND 44).

SIMON TENG, EXAMINING ATTORNEY

**CLASS 10—(Continued).**

SN 85-153,814. JOINT REPLACEMENT INSTRUMENTATION LIMITED, LONDON, UNITED KINGDOM, FILED 10-15-2010.



PRIORITY CLAIMED UNDER SEC. 44(D) ON ERPN CMNTY TM OFC APPLICATION NO. 009035155, FILED 4-16-2010, REG. NO. 009035155, DATED 9-14-2010, EXPIRES 4-16-2020.

NO CLAIM IS MADE TO THE EXCLUSIVE RIGHT TO USE "ORTHOPAEDICS", APART FROM THE MARK AS SHOWN.

THE COLOR(S) BLUE IS/ARE CLAIMED AS A FEATURE OF THE MARK.

THE MARK CONSISTS OF LOWERCASE STYLIZED LETTERS "JRI" CONTAINING SHADING OF DIFFERENT HUES OF BLUE. THE DOT OVER THE LETTER "I" IS A BLUE CIRCLE. WITHIN THE BLUE CIRCLE IS AN OVAL WHICH ALSO CONTAINS SHADING OF DIFFERENT HUES OF BLUE. THE LETTERS "JRI" APPEAR ABOVE THE WORD "ORTHOPAEDICS". UNDERNEATH THE WORD "ORTHOPAEDICS" IS THE PHRASE "INNOVATION IN PRACTICE", WHICH PHRASE IS CONTAINED BETWEEN TWO HORIZONTAL LINES.

FOR ORTHOPAEDIC IMPLANTS MADE FROM ARTIFICIAL MATERIAL; BONE, SHOULDER, KNEE, HIP, JOINT, LEG, FOOT, ARM AND HAND PROSTHESES; ORTHOPAEDIC IMPLANTS AND PROSTHESES; APPARATUS, ARTICLES AND INSTRUMENTS, ALL FOR ORTHOPAEDIC USE, NAMELY, ORTHOPAEDIC FIXATION DEVICES USED IN ORTHOPAEDIC TRANSPLANT OR IMPLANT SURGERY; SURGICAL INSTRUMENTS, NAMELY, DEVICES USED IN ORTHOPAEDIC SURGERY TO POSITION SURGICAL INSTRUMENTS, IMPLANTS AND/OR A PATIENT'S LIMBS; STEMS AND HEADS OF PROSTHESES; CUPS FOR PROSTHESES; STRUCTURAL PARTS AND FITTINGS FOR ALL THE AFORESAID GOODS; SCREWS FOR SECURING PROSTHESES; SYNTHETIC MATERIAL FOR SURGICAL USE FOR COATING ORTHOPAEDIC IMPLANTS AND PROSTHESES; MEDICAL DEVICES, NAMELY, SLEEVES OR THIMBLES OF COATING MATERIAL FOR POSITIONING OR ASSISTING BONE GROWTH TO SECURE PROSTHESES; SUTURE MATERIALS (U.S. CLS. 26, 39 AND 44).

SIMON TENG, EXAMINING ATTORNEY

**CLASS 10—(Continued).**

SN 85-153,873. JOINT REPLACEMENT INSTRUMENTATION LIMITED, LONDON, UNITED KINGDOM, FILED 10-15-2010.



PRIORITY CLAIMED UNDER SEC. 44(D) ON ERPN CMNTY TM OFC APPLICATION NO. 009035056, FILED 4-16-2010, REG. NO. 009035056, DATED 9-28-2010, EXPIRES 4-16-2020.

THE COLOR(S) ORANGE AND WHITE IS/ARE CLAIMED AS A FEATURE OF THE MARK.

THE MARK CONSISTS OF A "V" LOGO IN WHITE ON AN ORANGE CIRCLE AND AN OVAL CONTAINING SHADING OF DIFFERENT HUES OF ORANGE WITHIN THE SAME ORANGE CIRCLE.

FOR ORTHOPAEDIC IMPLANTS MADE FROM ARTIFICIAL MATERIAL; BONE, SHOULDER, KNEE, HIP, JOINT, LEG, FOOT, ARM AND HAND PROSTHESES; ORTHOPAEDIC IMPLANTS AND PROSTHESES; APPARATUS, ARTICLES AND INSTRUMENTS, ALL FOR ORTHOPAEDIC USE, NAMELY, ORTHOPAEDIC FIXATION DEVICES USED IN ORTHOPAEDIC TRANSPLANT OR IMPLANT SURGERY; SURGICAL INSTRUMENTS, NAMELY, DEVICES USED IN ORTHOPAEDIC SURGERY TO POSITION SURGICAL INSTRUMENTS, IMPLANTS AND/OR A PATIENT'S LIMBS; STEMS AND HEADS OF PROSTHESES; CUPS FOR PROSTHESES; STRUCTURAL PARTS AND FITTINGS FOR ALL THE AFORESAID GOODS; SCREWS FOR SECURING PROSTHESES; SYNTHETIC MATERIAL FOR SURGICAL USE FOR COATING ORTHOPAEDIC IMPLANTS AND PROSTHESES; MEDICAL DEVICES, NAMELY, SLEEVES OR THIMBLES OF COATING MATERIAL FOR POSITIONING OR ASSISTING BONE GROWTH TO SECURE PROSTHESES; SUTURE MATERIALS (U.S. CLS. 26, 39 AND 44).

SIMON TENG, EXAMINING ATTORNEY

SN 85-154,927. TRANSENERIX, INC., MORRISVILLE, NC. FILED 10-18-2010.

## ENABLING MICRO LAPAROSCOPY

THE MARK CONSISTS OF STANDARD CHARACTERS WITHOUT CLAIM TO ANY PARTICULAR FONT, STYLE, SIZE, OR COLOR.

NO CLAIM IS MADE TO THE EXCLUSIVE RIGHT TO USE "MICRO LAPAROSCOPY", APART FROM THE MARK AS SHOWN.

FOR MEDICAL DEVICES, NAMELY, SURGICAL DEVICES FOR USE IN LAPAROSCOPIC PROCEDURES (U.S. CLS. 26, 39 AND 44).

ALYSSA STEEL, EXAMINING ATTORNEY

**CLASS 10—(Continued).**

SN 85-154,929. TRANSENERIX, INC., MORRISVILLE, NC. FILED 10-18-2010.

## ENABLING FLEXIBLE LAPAROSCOPY

THE MARK CONSISTS OF STANDARD CHARACTERS WITHOUT CLAIM TO ANY PARTICULAR FONT, STYLE, SIZE, OR COLOR.

NO CLAIM IS MADE TO THE EXCLUSIVE RIGHT TO USE "FLEXIBLE LAPAROSCOPY", APART FROM THE MARK AS SHOWN.

FOR MEDICAL DEVICES, NAMELY, SURGICAL DEVICES FOR USE IN LAPAROSCOPIC PROCEDURES (U.S. CLS. 26, 39 AND 44).

ALYSSA STEEL, EXAMINING ATTORNEY

SN 85-155,666. CEANIX HEALTH INC., COLLINGWOOD, CANADA, FILED 10-19-2010.



THE MARK CONSISTS OF THE LITERAL ELEMENT "TORTOISE SHELLZ" WITH A DESIGN ELEMENT CENTERED ABOVE THE WORDS. THE DESIGN ELEMENT CONSISTS OF TWO (2) RINGS EVENLY SPACED AROUND A SMALL CIRCLE IN THE CENTER. THE OUTERMOST RING CONSISTS OF FIVE (5) ROUNDED LINES EXTENDING OUTWARD FROM THE TOP, THE BOTTOM, THE UPPERMOST RIGHT-HAND CORNER, THE LEFT AND THE RIGHT SIDES, WITH ONE (1) POINTED LINE EXTENDING OUTWARD FROM THE BOTTOM-MOST LEFT-HAND CORNER.

FOR INFRARED RADIATOR UNITS FOR THERAPEUTIC PURPOSES (U.S. CLS. 26, 39 AND 44).

KATHERINE M. DUBRAY, EXAMINING ATTORNEY

SN 85-157,124. MAXX ORTHOPEDICS, INC., PLYMOUTH MEETING, PA. FILED 10-20-2010.

## FREEDOM REVISION KNEE

THE MARK CONSISTS OF STANDARD CHARACTERS WITHOUT CLAIM TO ANY PARTICULAR FONT, STYLE, SIZE, OR COLOR.

OWNER OF U.S. REG. NOS. 3,435,708 AND 3,449,377.

NO CLAIM IS MADE TO THE EXCLUSIVE RIGHT TO USE "REVISION KNEE", APART FROM THE MARK AS SHOWN.

FOR ORTHOPEDIC JOINT IMPLANTS; SURGICAL APPARATUS AND INSTRUMENTS FOR USE IN ORTHOPEDIC SURGERY (U.S. CLS. 26, 39 AND 44).

LINDA M. KING, EXAMINING ATTORNEY

**CLASS 10—(Continued).**

SN 85-158,540. DELUCA, HELENA A, DBA DR. HELENA A DELUCA, SUNRISE, FL. FILED 10-21-2010.

## SI-SO THE SNAP-IN SNAP-OVER DENTAL APPLIANCE

THE MARK CONSISTS OF STANDARD CHARACTERS WITHOUT CLAIM TO ANY PARTICULAR FONT, STYLE, SIZE, OR COLOR.

NO CLAIM IS MADE TO THE EXCLUSIVE RIGHT TO USE "DENTAL APPLIANCE", APART FROM THE MARK AS SHOWN.

FOR DENTAL PROSTHESES (U.S. CLS. 26, 39 AND 44).  
ELISSA GARBER KON, EXAMINING ATTORNEY

SN 85-166,146. SYNERON CANADA CORPORATION, RICHMOND HILL, ONTARIO, CANADA, FILED 11-1-2010.

## TRANSCEND

THE MARK CONSISTS OF STANDARD CHARACTERS WITHOUT CLAIM TO ANY PARTICULAR FONT, STYLE, SIZE, OR COLOR.

FOR MEDICAL AND ESTHETIC DEVICE USING ELECTRICAL AND OPTICAL ENERGY FOR TREATMENT OF SOFT TISSUE, NAMELY, CIRCUMFERENCE REDUCTION (U.S. CLS. 26, 39 AND 44).

KEVIN CORWIN, EXAMINING ATTORNEY

SN 85-166,461. U.S. JACLEAN, INC., GARDENA, CA. FILED 11-1-2010.

## Ninja Shoulder Massager

THE MARK CONSISTS OF STANDARD CHARACTERS WITHOUT CLAIM TO ANY PARTICULAR FONT, STYLE, SIZE, OR COLOR.

NO CLAIM IS MADE TO THE EXCLUSIVE RIGHT TO USE "SHOULDER MASSAGER", APART FROM THE MARK AS SHOWN.

FOR MASSAGING APPARATUS FOR PERSONAL USE (U.S. CLS. 26, 39 AND 44).

RICHARD WHITE, EXAMINING ATTORNEY

**CLASS 10—(Continued).**

SN 85-167,826. CONFLUENT SURGICAL, INC., BEDFORD, MA. FILED 11-3-2010.

**VERISET**

THE MARK CONSISTS OF STANDARD CHARACTERS WITHOUT CLAIM TO ANY PARTICULAR FONT, STYLE, SIZE, OR COLOR.

FOR SURGICAL IMPLANTS COMPRISING ARTIFICIAL MATERIALS IN THE NATURE OF ABSORBABLE SURGICAL HEMOSTATS FOR CONTROLLING BLEEDING (U.S. CLS. 26, 39 AND 44).

LAURIE MAYES, EXAMINING ATTORNEY

SN 85-171,808. BSN MEDICAL GMBH, HAMBURG, FED REP GERMANY, FILED 11-8-2010.

MAKES YOUR LEGS LOOK AS  
GOOD AS THEY FEEL!

THE MARK CONSISTS OF STANDARD CHARACTERS WITHOUT CLAIM TO ANY PARTICULAR FONT, STYLE, SIZE, OR COLOR.

FOR ORTHOPAEDIC HOSIERY, NAMELY, ORTHOPAEDIC COMPRESSION AND SUPPORT STOCKINGS, TIGHTS AND SOCKS; MEDICAL HOSIERY, NAMELY, MEDICAL AND SUPPORT STOCKINGS, TIGHTS AND SOCKS (U.S. CLS. 26, 39 AND 44).

LESLIE RICHARDS, EXAMINING ATTORNEY

SN 85-173,720. KARMELSONIX (ISRAEL) LTD., HAIFA, ISRAEL, FILED 11-10-2010.

**WHOLTER**

THE MARK CONSISTS OF STANDARD CHARACTERS WITHOUT CLAIM TO ANY PARTICULAR FONT, STYLE, SIZE, OR COLOR.

FOR MEDICAL DEVICE FOR MONITORING, DISPLAYING AND DIAGNOSING RESPIRATION AND THE PULMONARY SYSTEM TO DETERMINE PARAMETERS ASSOCIATED WITH THEIR STATE OF HEALTH BY SENSING, RECORDING AND ANALYZING ACOUSTIC SIGNALS EMITTED THEREFROM AND USING THESE PARAMETERS TO INFER THE STATE OF HEALTH OF THE PULMONARY SYSTEM AND RESPIRATION RELATING TO THEIR FUNCTIONS, ABNORMALITIES, CONDITIONS AND DISEASES (U.S. CLS. 26, 39 AND 44).

FIRST USE 3-2-2010; IN COMMERCE 3-2-2010.  
ZHALEH DELANEY, EXAMINING ATTORNEY

**CLASS 10—(Continued).**

SN 85-173,738. GLOBUS MEDICAL, INC., AUDUBON, PA. FILED 11-10-2010.

**RENEGADE**

THE MARK CONSISTS OF STANDARD CHARACTERS WITHOUT CLAIM TO ANY PARTICULAR FONT, STYLE, SIZE, OR COLOR.

FOR SPINAL IMPLANTS MADE FROM ARTIFICIAL MATERIALS FOR USE IN SPINE SURGERY (U.S. CLS. 26, 39 AND 44).

MARTHA FROMM, EXAMINING ATTORNEY

SN 85-173,785. GLOBUS MEDICAL, INC., AUDUBON, PA. FILED 11-10-2010.

**FORTIFY**

THE MARK CONSISTS OF STANDARD CHARACTERS WITHOUT CLAIM TO ANY PARTICULAR FONT, STYLE, SIZE, OR COLOR.

FOR SPINAL IMPLANTS MADE FROM ARTIFICIAL MATERIALS FOR USE IN SPINE SURGERY (U.S. CLS. 26, 39 AND 44).

MARTHA FROMM, EXAMINING ATTORNEY

SN 85-174,606. TORNIER, INC., EDINA, MN. FILED 11-11-2010.

**SOLOSTITCH**

THE MARK CONSISTS OF STANDARD CHARACTERS WITHOUT CLAIM TO ANY PARTICULAR FONT, STYLE, SIZE, OR COLOR.

FOR MEDICAL INSTRUMENT, NAMELY, A DISPOSABLE SURGICAL INSTRUMENT USED FOR MEASURING AND SUTURE MANAGEMENT (U.S. CLS. 26, 39 AND 44).

ELLEN BURNS, EXAMINING ATTORNEY



**CLASS 10—(Continued).**

SN 85-174,616. TORNIER, INC., EDINA, MN. FILED 11-11-2010.

# GRAFTPORT

THE MARK CONSISTS OF STANDARD CHARACTERS WITHOUT CLAIM TO ANY PARTICULAR FONT, STYLE, SIZE, OR COLOR.

FOR MEDICAL INSTRUMENT, NAMELY, A CANNULA TO FACILITATE SKIN GRAFTING TO THE OPERATIVE SITE THROUGH THE SKIN (U.S. CLS. 26, 39 AND 44).

ELLEN BURNS, EXAMINING ATTORNEY

SN 85-176,110. SDS DENTAL INC., AKA SUMMIT DENTAL SYSTEMS, FORT LAUDERDALE, FL. FILED 11-13-2010.



THE MARK CONSISTS OF A STYLIZED CHAIR WITHIN AN ELIPSE.

FOR AUTOCLAVES FOR MEDICAL USE (U.S. CLS. 26, 39 AND 44).

ROBIN CHOSID, EXAMINING ATTORNEY

SN 85-176,199. KALLOWS, INC., MILWAUKEE, WI. FILED 11-13-2010.

# KALLOWS

THE MARK CONSISTS OF STANDARD CHARACTERS WITHOUT CLAIM TO ANY PARTICULAR FONT, STYLE, SIZE, OR COLOR.

FOR BELTS FOR ATTACHING MEDICAL MONITORS TO PATIENTS; BLOOD PRESSURE AND DIABETIC DIAGNOSTIC MEDICAL DEVICES; BLOOD PRESSURE MEASURING APPARATUS; BLOOD PRESSURE MONITORS; EKG MACHINES; ELECTROENCEPHALOGRAPHY KIT CONSISTING OF AN ELECTRODE HEADSET, A DIGITAL RECORDER AND TRANSMITTER, A TABLET COMPUTER MONITOR, AND INSTRUCTIONS FOR USE IN MEDICAL SETTINGS INCLUDING EMERGENCY DEPARTMENTS, AMBULANCES, INTENSIVE CARE UNITS, AND PHYSICIAN'S OFFICES; EXERCISE MACHINES FOR THERAPEUTIC PURPOSES; FETAL PULSE MONITORS; HEALTH MONITORING DEVICES, NAMELY, BLOOD PRESSURE MONITORS, THERMOMETERS AND PEDOMETERS; HEALTH MONITORS COMPRISING SENSOR THAT MONITOR THE HEALTH OF THE ELDERLY OR HANDICAPPED IN THEIR OWN HOMES; HEART MONITORS; HEART MONITORS TO BE WORN DURING EXERCISE; HEART RATE MONITORS; IN-EAR MONITORS FOR MEDICAL PURPOSES;

**CLASS 10—(Continued).**

MEDICAL AND THERAPEUTIC DEVICE AND APPARATUS, NAMELY, A FORCE AND MOTION SENSING APPARATUS AND ASSISTED EXERCISE MACHINE FOR THE REHABILITATION OF MUSCLES AFFECTED BY NEUROMUSCULAR DISEASES, DISORDERS, OR INJURIES FOR HOME OR CLINICAL USE; MEDICAL APPARATUS AND INSTRUMENTS FOR MONITORING BLOOD PROPERTIES AND RESPIRATORY EVENTS; MEDICAL APPARATUS AND INSTRUMENTS FOR MONITORING OXYMETRY, GAS ANALYSIS AND VITAL SIGNS; MEDICAL APPARATUS AND INSTRUMENTS FOR MONITORING OXYMETRY, GAS ANALYSIS, VITAL SIGNS, BLOOD PROPERTIES AND RESPIRATORY EVENTS; MEDICAL APPARATUS AND INSTRUMENTS FOR MONITORING OXYMETRY, GAS ANALYSIS, VITAL SIGNS, BLOOD PROPERTIES AND RESPIRATORY EVENTS AND SOFTWARE SOLD THEREWITH AS A UNIT; MEDICAL APPARATUS AND INSTRUMENTS FOR MONITORING VITAL SIGNS, BLOOD PROPERTIES AND RESPIRATORY EVENTS; MEDICAL APPARATUS, NAMELY, FETAL AND MATERNAL VITAL SIGN AND PHYSICAL DISTRESS MONITORS; MEDICAL APPARATUS, NAMELY, RESPIRATORY EQUIPMENT AND MONITORS THEREFOR; MEDICAL DEVICE, NAMELY, CARBON DIOXIDE INDICATORS; MEDICAL DEVICES FOR MONITORING BLOOD PROPERTIES AND RESPIRATORY EVENTS; MEDICAL DEVICES FOR MONITORING OXYMETRY, GAS ANALYSIS AND VITAL SIGNS; MEDICAL DEVICES FOR MONITORING OXYMETRY, GAS ANALYSIS, VITAL SIGNS, BLOOD PROPERTIES AND RESPIRATORY EVENTS; MEDICAL DEVICES FOR MONITORING OXYMETRY, GAS ANALYSIS, VITAL SIGNS, BLOOD PROPERTIES AND RESPIRATORY EVENTS AND SOFTWARE SOLD AS A UNIT THEREWITH; MEDICAL DEVICES FOR MONITORING OXYMETRY, GAS ANALYSIS, VITAL SIGNS, BLOOD PROPERTIES AND RESPIRATORY EVENTS AND SYSTEM THAT TRANSMIT THE DATA THROUGH THE INTERNET; MEDICAL DEVICES FOR MONITORING VITAL SIGNS, BLOOD PROPERTIES AND RESPIRATORY EVENTS; MEDICAL DEVICES, NAMELY, PATIENT MONITORS AND PATIENT SENSORS FOR MONITORING AND MEASURING BLOOD PROPERTIES AND RESPIRATORY EVENTS; MEDICAL DIAGNOSTIC APPARATUS, ANALYTICAL APPARATUS FOR MEDICAL PURPOSES AND BLOOD PRESSURE MEASURING APPARATUS; MEDICAL INSTRUMENTS TO MEASURE BLOOD PRESSURE, CARDIAC OUTPUT AND OTHER PHYSIOLOGICAL AND CARDIOVASCULAR PARAMETERS; PATIENT MEDICAL MONITORS, NAMELY, MONITORS FOR SURGICAL STIMULATION, ANALGESIA AND HYPNOTIC RELATED RESPONSES; PATIENT MONITORING SENSORS AND ALARMS; PATIENT MONITORS FOR CRITICAL CARE AND ANESTHESIA; PHYSICAL EXERCISE APPARATUS, FOR MEDICAL PURPOSES; PORTABLE MEDICAL DEVICES USED FOR BREATHING EXERCISES, NAMELY, PORTABLE DEVICES USED FOR ENDOGENOUS BREATHING EXERCISES AND FOR RESPIRATORY MUSCLE TRAINING; PORTABLE MEDICAL DEVICES WITH SENSORS TO MONITOR THE PHYSICAL MOVEMENTS OF A PATIENT WEARING OR CARRYING THE DEVICE; PULSE RATE MONITORS; RESPIRATION MONITORS (U.S. CLS. 26, 39 AND 44).

JAMES GRIFFIN, EXAMINING ATTORNEY

**CLASS 10—(Continued).**

SN 85-176,551. BSN MEDICAL, INC., CHARLOTTE, NC.  
FILED 11-15-2010.

**ACTION-FIT**

THE MARK CONSISTS OF STANDARD CHARACTERS  
WITHOUT CLAIM TO ANY PARTICULAR FONT, STYLE,  
SIZE, OR COLOR.

FOR ORTHOPEDIC SUPPORTS (U.S. CLS. 26, 39 AND  
44).

TOBY BULLOFF, EXAMINING ATTORNEY

**CLASS 10—(Continued).**

SN 85-176,685. COLOPLAST A/S, HUMLEBAEK, DENMARK,  
FILED 11-15-2010.

**SUTURES SMART**

THE MARK CONSISTS OF STANDARD CHARACTERS  
WITHOUT CLAIM TO ANY PARTICULAR FONT, STYLE,  
SIZE, OR COLOR.

FOR COMPONENT PART OF MEDICAL SURGICAL  
APPARATUS FOR PLACING SUTURES IN TRANSVA-  
GINAL AND GYNECOLOGICAL SURGERY, NAMELY,  
PRE-LOADED SUTURE CARTRIDGE (U.S. CLS. 26, 39  
AND 44).

C. DIONNE CLYBURN, EXAMINING ATTORNEY

SN 85-176,585. SUNRISE ANIMAL HEALTH CORPORA-  
TION, LEXINGTON, KY. FILED 11-15-2010.

**HEATSPOT2X**

THE MARK CONSISTS OF STANDARD CHARACTERS  
WITHOUT CLAIM TO ANY PARTICULAR FONT, STYLE,  
SIZE, OR COLOR.

FOR PRESSURE RESPONSIVE DEVICE FOR USE IN  
THE DETECTION OF ESTRUS IN ANIMALS (U.S. CLS.  
26, 39 AND 44).

CURTIS FRENCH, EXAMINING ATTORNEY

SN 85-176,722. APEN MEDICAL PRODUCTS, INC., IRVINE,  
CA. FILED 11-15-2010.

**EVERGREEN**

THE MARK CONSISTS OF STANDARD CHARACTERS  
WITHOUT CLAIM TO ANY PARTICULAR FONT, STYLE,  
SIZE, OR COLOR.

FOR LOWER SPINE BRACING PRODUCTS (U.S. CLS.  
26, 39 AND 44).

C. DIONNE CLYBURN, EXAMINING ATTORNEY

SN 85-176,681. PIVOT MEDICAL, INC., SUNNYVALE, CA.  
FILED 11-15-2010.

**IT'S ABOUT TIME**

THE MARK CONSISTS OF STANDARD CHARACTERS  
WITHOUT CLAIM TO ANY PARTICULAR FONT, STYLE,  
SIZE, OR COLOR.

FOR MEDICAL DEVICES, NAMELY, INSTRUMENTS  
FOR USE IN ARTHROSCOPIC SURGERY, NAMELY,  
ORTHOPEDIC FIXATION DEVICES (U.S. CLS. 26, 39  
AND 44).

JOHN GARTNER, EXAMINING ATTORNEY

SN 85-176,735. COLOPLAST A/S, HUMLEBAEK, DENMARK,  
FILED 11-15-2010.

**FLEXISHAFT**

THE MARK CONSISTS OF STANDARD CHARACTERS  
WITHOUT CLAIM TO ANY PARTICULAR FONT, STYLE,  
SIZE, OR COLOR.

FOR COMPONENT PART OF MEDICAL SURGICAL  
APPARATUS FOR PLACING SUTURES IN TRANSVA-  
GINAL AND GYNECOLOGICAL SURGERY, NAMELY,  
MULTI-DIRECTIONAL DELIVERY HEAD EXTENSION  
(U.S. CLS. 26, 39 AND 44).

C. DIONNE CLYBURN, EXAMINING ATTORNEY

**CLASS 10—(Continued).**

SN 85-177,483. FLYNN, GREGORY, TAMPA, FL. FILED 11-16-2010.

**NEURO~FLEXLASER**

THE MARK CONSISTS OF STANDARD CHARACTERS WITHOUT CLAIM TO ANY PARTICULAR FONT, STYLE, SIZE, OR COLOR.

FOR MEDICAL DEVICE, NAMELY, A FLEXIBLE LASER USED FOR THE REMOVAL OF SOFT TISSUE WITHIN THE HUMAN BODY (U.S. CLS. 26, 39 AND 44).  
IRA J. GOODSaid, EXAMINING ATTORNEY

SN 85-177,494. RADIOMED CORPORATION, BARTLETT, TN. FILED 11-16-2010.

**VISICOIL**

THE MARK CONSISTS OF STANDARD CHARACTERS WITHOUT CLAIM TO ANY PARTICULAR FONT, STYLE, SIZE, OR COLOR.

FOR MEDICAL APPARATUS AND INSTRUMENT FOR DIAGNOSTIC USE, NAMELY, APPARATUS FOR MEDICAL DIAGNOSTIC TESTING IN THE FIELDS OF CANCER OR OTHER TISSUE-BASED DIAGNOSTIC TESTING, CYTOLOGY AND CELL-BASED TESTING (U.S. CLS. 26, 39 AND 44).  
FIRST USE 12-1-2002; IN COMMERCE 3-13-2003.  
KARANENDRA S. CHHINA, EXAMINING ATTORNEY

SN 85-177,594. ANSELL LIMITED, RICHMOND, AUSTRALIA, FILED 11-16-2010.

**LIFESTYLES WYLD**

THE MARK CONSISTS OF STANDARD CHARACTERS WITHOUT CLAIM TO ANY PARTICULAR FONT, STYLE, SIZE, OR COLOR.

OWNER OF U.S. REG. NOS. 1,185,626, 3,848,422 AND OTHERS.  
FOR CONDOMS (U.S. CLS. 26, 39 AND 44).  
FIRST USE 4-10-2010; IN COMMERCE 4-10-2010.  
SEAN CROWLEY, EXAMINING ATTORNEY

**CLASS 10—(Continued).**

SN 85-177,600. ANSELL LIMITED, RICHMOND, AUSTRALIA, FILED 11-16-2010.

**LIFESTYLES KYNG**

THE MARK CONSISTS OF STANDARD CHARACTERS WITHOUT CLAIM TO ANY PARTICULAR FONT, STYLE, SIZE, OR COLOR.

OWNER OF U.S. REG. NOS. 1,185,626, 3,848,422 AND OTHERS.  
FOR CONDOMS (U.S. CLS. 26, 39 AND 44).  
FIRST USE 4-12-2009; IN COMMERCE 4-12-2009.  
SEAN CROWLEY, EXAMINING ATTORNEY

SN 85-177,738. WOUNDVISION, LLC, INDIANAPOLIS, IN. FILED 11-16-2010.

**WOUNDVISION INSIGHT**

THE MARK CONSISTS OF STANDARD CHARACTERS WITHOUT CLAIM TO ANY PARTICULAR FONT, STYLE, SIZE, OR COLOR.

FOR THERMOGRAPHIC SKIN AND TISSUE ANALYZERS FOR MEDICAL DIAGNOSTICS (U.S. CLS. 26, 39 AND 44).  
MARK SHINER, EXAMINING ATTORNEY

SN 85-177,762. WOUNDVISION, LLC, INDIANAPOLIS, IN. FILED 11-16-2010.

**WOUNDVISION INSIGHT PLUS**

THE MARK CONSISTS OF STANDARD CHARACTERS WITHOUT CLAIM TO ANY PARTICULAR FONT, STYLE, SIZE, OR COLOR.

FOR THERMOGRAPHIC SKIN AND TISSUE ANALYZERS FOR MEDICAL DIAGNOSTICS (U.S. CLS. 26, 39 AND 44).  
MARK SHINER, EXAMINING ATTORNEY

**CLASS 10—(Continued).**

SN 85-177,824. PRECISION POLARITY, LLC, AKA PRECISION POLARITY, QUAKERTOWN, NJ. FILED 11-16-2010.

**PRECISION POLARITY**

THE MARK CONSISTS OF STANDARD CHARACTERS WITHOUT CLAIM TO ANY PARTICULAR FONT, STYLE, SIZE, OR COLOR.

FOR MAGNETIC DEVICES USED FOR PROVIDING THERAPEUTIC TREATMENT TO PATIENTS AND CLIENTS (U.S. CLS. 26, 39 AND 44).

SUSAN LESLIE DUBOIS, EXAMINING ATTORNEY

**CLASS 10—(Continued).**

SN 85-177,950. BEAVER-VISITEC INTERNATIONAL (U.S.), INC., LAKE FOREST, IL. FILED 11-16-2010.

**KEEPING YOUR VISION IN SIGHT**

THE MARK CONSISTS OF STANDARD CHARACTERS WITHOUT CLAIM TO ANY PARTICULAR FONT, STYLE, SIZE, OR COLOR.

FOR SURGICAL APPARATUS AND INSTRUMENTS FOR USE IN OPHTHALMIC SURGERY (U.S. CLS. 26, 39 AND 44).

AMY ALFIERI, EXAMINING ATTORNEY

SN 85-177,833. PRECISION POLARITY, LLC, AKA PRECISION POLARITY, QUAKERTOWN, NJ. FILED 11-16-2010.

**PRECISION POLARITY NEO**

THE MARK CONSISTS OF STANDARD CHARACTERS WITHOUT CLAIM TO ANY PARTICULAR FONT, STYLE, SIZE, OR COLOR.

FOR MAGNETIC DEVICES USED FOR PROVIDING THERAPEUTIC TREATMENT TO PATIENTS AND CLIENTS (U.S. CLS. 26, 39 AND 44).

SUSAN LESLIE DUBOIS, EXAMINING ATTORNEY

SN 85-178,025. KLEARMAN, JEFFREY DEAN, SAINT LOUIS, MO. FILED 11-16-2010.

**Lovejoy**

THE MARK CONSISTS OF STANDARD CHARACTERS WITHOUT CLAIM TO ANY PARTICULAR FONT, STYLE, SIZE, OR COLOR.

FOR ADULT SEXUAL STIMULATION AIDS, NAMELY, VIBRATING INTERCOURSE RING (U.S. CLS. 26, 39 AND 44).

ERIN FALK, EXAMINING ATTORNEY

SN 85-177,936. BEAVER-VISITEC INTERNATIONAL (U.S.), INC., LAKE FOREST, IL. FILED 11-16-2010.

**OUR VISION IS ON YOUR SIGHT**

THE MARK CONSISTS OF STANDARD CHARACTERS WITHOUT CLAIM TO ANY PARTICULAR FONT, STYLE, SIZE, OR COLOR.

FOR SURGICAL APPARATUS AND INSTRUMENTS FOR USE IN OPHTHALMIC SURGERY (U.S. CLS. 26, 39 AND 44).

AMY ALFIERI, EXAMINING ATTORNEY

SN 85-178,034. MAQUET CARDIOVASCULAR LLC, SAN JOSE, CA. FILED 11-16-2010.

**LINEAR**

THE MARK CONSISTS OF STANDARD CHARACTERS WITHOUT CLAIM TO ANY PARTICULAR FONT, STYLE, SIZE, OR COLOR.

FOR MEDICAL CATHETERS AND MEDICAL BALLOON CATHETERS; MEDICAL BALLOON CATHETERS SOLD AS A KIT WITH INSERTION TOOLS AND CONNECTORS (U.S. CLS. 26, 39 AND 44).

FIRST USE 8-1-2010; IN COMMERCE 8-1-2010.

JORDAN BAKER, EXAMINING ATTORNEY

**CLASS 10—(Continued).**

SN 85-178,088. MAQUET CARDIOVASCULAR LLC, SAN JOSE, CA. FILED 11-16-2010.

**MEGA**

THE MARK CONSISTS OF STANDARD CHARACTERS WITHOUT CLAIM TO ANY PARTICULAR FONT, STYLE, SIZE, OR COLOR.

FOR MEDICAL CATHETERS AND MEDICAL BALLOON CATHETERS; MEDICAL BALLOON CATHETERS SOLD AS A KIT WITH INSERTION TOOLS AND CONNECTORS (U.S. CLS. 26, 39 AND 44).

FIRST USE 6-1-2009; IN COMMERCE 6-1-2009.  
JORDAN BAKER, EXAMINING ATTORNEY

**CLASS 10—(Continued).**

SN 85-180,572. MOOREDESIGN ASSOCIATES LLC, PHOENIX, AZ. FILED 11-18-2010.

**INDEPENDENCE WAY**

THE MARK CONSISTS OF STANDARD CHARACTERS WITHOUT CLAIM TO ANY PARTICULAR FONT, STYLE, SIZE, OR COLOR.

FOR MEDICAL INSTRUMENTS FOR USE IN REHABILITATION (U.S. CLS. 26, 39 AND 44).

YAT SYE, LEE, EXAMINING ATTORNEY

SN 85-180,041. CHIPPENDALES USA, LLC, PLAINVIEW, NY. FILED 11-18-2010.

**CHIPPENDALES**

THE MARK CONSISTS OF STANDARD CHARACTERS WITHOUT CLAIM TO ANY PARTICULAR FONT, STYLE, SIZE, OR COLOR.

FOR ELECTRIC MASSAGE APPLIANCES, NAMELY, ELECTRIC VIBRATING MASSAGER (U.S. CLS. 26, 39 AND 44).

FIRST USE 10-1-2010; IN COMMERCE 10-1-2010.  
MIDGE BUTLER, EXAMINING ATTORNEY

SN 85-181,121. ORATECH, LLC, SOUTH JORDAN, UT. FILED 11-19-2010.

**TRIM-EZE**

THE MARK CONSISTS OF STANDARD CHARACTERS WITHOUT CLAIM TO ANY PARTICULAR FONT, STYLE, SIZE, OR COLOR.

FOR DENTAL PRODUCTS, NAMELY, INTERPROXIMAL COMPOSITE TRIMMER (U.S. CLS. 26, 39 AND 44).

DAVID YONTEF, EXAMINING ATTORNEY

SN 85-180,487. NCONTACT SURGICAL, INC., MORRISVILLE, NC. FILED 11-18-2010.

**SUBTLE**

THE MARK CONSISTS OF STANDARD CHARACTERS WITHOUT CLAIM TO ANY PARTICULAR FONT, STYLE, SIZE, OR COLOR.

FOR CATHETERS FOR COAGULATION OF TISSUE; ACCESS DEVICES, NAMELY, CANNULAE, CATHETERS, MEDICAL GUIDEWIRES, AND ENDOSCOPIC EQUIPMENT (U.S. CLS. 26, 39 AND 44).

CHRISTINA SOBRAL, EXAMINING ATTORNEY

SN 85-183,782. MEDTRONIC, INC., MINNEAPOLIS, MN. FILED 11-23-2010.

**MLTC**

THE MARK CONSISTS OF STANDARD CHARACTERS WITHOUT CLAIM TO ANY PARTICULAR FONT, STYLE, SIZE, OR COLOR.

FOR MEDICAL APPARATUS, NAMELY, A HOUSING FOR EXTERNAL LEADS USED IN SPINAL CORD STIMULATION (U.S. CLS. 26, 39 AND 44).

HEATHER BIDDULPH, EXAMINING ATTORNEY

**CLASS 10—(Continued).**

SN 85-197,211. GLOBUS MEDICAL, INC., AUDUBON, PA.  
FILED 12-14-2010.

**REVLOK**

THE MARK CONSISTS OF STANDARD CHARACTERS WITHOUT CLAIM TO ANY PARTICULAR FONT, STYLE, SIZE, OR COLOR.

FOR SPINAL IMPLANTS MADE FROM ARTIFICIAL MATERIALS FOR USE IN SPINE SURGERY (U.S. CLS. 26, 39 AND 44).

MARTHA FROMM, EXAMINING ATTORNEY

**CLASS 10—(Continued).**

SN 85-219,524. GLOBUS MEDICAL, INC., AUDUBON, PA.  
FILED 1-18-2011.

**COMPOSE**

THE MARK CONSISTS OF STANDARD CHARACTERS WITHOUT CLAIM TO ANY PARTICULAR FONT, STYLE, SIZE, OR COLOR.

FOR SURGICAL IMPLANTS, MADE FROM ARTIFICIAL MATERIALS, FOR USE IN ORTHOPEDIC SURGERY (U.S. CLS. 26, 39 AND 44).

MARTHA FROMM, EXAMINING ATTORNEY

SN 85-197,607. MEDTRONIC, INC., MINNEAPOLIS, MN.  
FILED 12-14-2010.

**ALSYNC**

THE MARK CONSISTS OF STANDARD CHARACTERS WITHOUT CLAIM TO ANY PARTICULAR FONT, STYLE, SIZE, OR COLOR.

FOR MEDICAL DEVICES, NAMELY, CARDIAC PACING LEAD, PACING LEAD DELIVERY CATHETER, CARDIAC PACEMAKER AND CARDIAC DEFIBRILLATOR (U.S. CLS. 26, 39 AND 44).

HEATHER BIDDULPH, EXAMINING ATTORNEY

SN 85-223,809. OAKWELL DISTRIBUTION, INC., DBA  
DEVON MEDICAL PRODUCTS, KING OF PRUSSIA, PA.  
FILED 1-22-2011.

**ArterioFlow**

THE MARK CONSISTS OF STANDARD CHARACTERS WITHOUT CLAIM TO ANY PARTICULAR FONT, STYLE, SIZE, OR COLOR.

FOR MEDICAL APPARATUS FOR IMPROVEMENT OF BLOOD CIRCULATION IN THE LOWER EXTREMITIES THROUGH AN APPLICATION OF INTERMITTENT COMPRESSION TO THE FOOT AND LOWER LEG AND HAVING A PUMP, TUBING AND INFLATABLE GARMENT (U.S. CLS. 26, 39 AND 44).

JORDAN BAKER, EXAMINING ATTORNEY

SN 85-204,218. LIFEBACK ENTERPRISES, INC., TARPON  
SPRINGS, FL. FILED 12-22-2010.

**GET YOUR LIFEBACK!**

THE MARK CONSISTS OF STANDARD CHARACTERS WITHOUT CLAIM TO ANY PARTICULAR FONT, STYLE, SIZE, OR COLOR.

OWNER OF U.S. REG. NO. 3,477,698.  
FOR BELTS FOR MEDICAL PURPOSES; ORTHOPEDIC BELTS (U.S. CLS. 26, 39 AND 44).

FIRST USE 1-18-2011; IN COMMERCE 1-18-2011.

AMY KERTGATE, EXAMINING ATTORNEY

SN 85-224,074. COLOPLAST A/S, HUMLEBAEK, DENMARK,  
FILED 1-24-2011.

**GYNEIDEAS**

THE MARK CONSISTS OF STANDARD CHARACTERS WITHOUT CLAIM TO ANY PARTICULAR FONT, STYLE, SIZE, OR COLOR.

FOR WOMEN'S HEALTH MEDICAL DEVICES FOR TREATING INCONTINENCE AND DEVICES FOR PELVIC FLOOR RECONSTRUCTION (U.S. CLS. 26, 39 AND 44).

C. DIONNE CLYBURN, EXAMINING ATTORNEY

**CLASS 10—(Continued).**

SN 85-224,083. COLOPLAST A/S, HUMLEBAEK, DENMARK, FILED 1-24-2011.

# PELVIX

THE MARK CONSISTS OF STANDARD CHARACTERS WITHOUT CLAIM TO ANY PARTICULAR FONT, STYLE, SIZE, OR COLOR.

FOR WOMEN'S HEALTH MEDICAL DEVICES FOR TREATING INCONTINENCE AND DEVICES FOR PELVIC FLOOR RECONSTRUCTION (U.S. CLS. 26, 39 AND 44).

C. DIONNE CLYBURN, EXAMINING ATTORNEY



SN 85-224,095. COLOPLAST A/S, HUMLEBAEK, DENMARK, FILED 1-24-2011.

# VARITAPE

THE MARK CONSISTS OF STANDARD CHARACTERS WITHOUT CLAIM TO ANY PARTICULAR FONT, STYLE, SIZE, OR COLOR.

FOR WOMEN'S HEALTH MEDICAL DEVICES FOR TREATING INCONTINENCE AND DEVICES FOR PELVIC FLOOR RECONSTRUCTION (U.S. CLS. 26, 39 AND 44).

C. DIONNE CLYBURN, EXAMINING ATTORNEY



SN 85-248,003. ANSELL LIMITED, RICHMOND, AUSTRALIA, FILED 2-22-2011.

# LIFESTYLES 3SUM

THE MARK CONSISTS OF STANDARD CHARACTERS WITHOUT CLAIM TO ANY PARTICULAR FONT, STYLE, SIZE, OR COLOR.

OWNER OF U.S. REG. NOS. 1,185,626, 3,534,659 AND OTHERS.  
FOR CONDOMS (U.S. CLS. 26, 39 AND 44).  
SEAN CROWLEY, EXAMINING ATTORNEY

**CLASS 10—(Continued).**

SN 85-248,010. ANSELL LIMITED, RICHMOND, AUSTRALIA, FILED 2-22-2011.

# LIFESTYLES TRIO

THE MARK CONSISTS OF STANDARD CHARACTERS WITHOUT CLAIM TO ANY PARTICULAR FONT, STYLE, SIZE, OR COLOR.

OWNER OF U.S. REG. NOS. 1,185,626, 3,534,659 AND OTHERS.

FOR CONDOMS (U.S. CLS. 26, 39 AND 44).

SEAN CROWLEY, EXAMINING ATTORNEY



SN 85-248,018. ANSELL LIMITED, RICHMOND, AUSTRALIA, FILED 2-22-2011.

# LIFESTYLES BLACK LABEL

THE MARK CONSISTS OF STANDARD CHARACTERS WITHOUT CLAIM TO ANY PARTICULAR FONT, STYLE, SIZE, OR COLOR.

OWNER OF U.S. REG. NOS. 1,185,626, 3,534,659 AND OTHERS.

FOR CONDOMS (U.S. CLS. 26, 39 AND 44).

SEAN CROWLEY, EXAMINING ATTORNEY



**CLASS 11—ENVIRONMENTAL CONTROL APPARATUS**

SN 77-474,205. TROJAN TECHNOLOGIES, LONDON, CANADA, FILED 5-14-2008.

# TROJANUVFIT

THE MARK CONSISTS OF STANDARD CHARACTERS WITHOUT CLAIM TO ANY PARTICULAR FONT, STYLE, SIZE, OR COLOR.

PRIORITY CLAIMED UNDER SEC. 44(D) ON CANADA APPLICATION NO. 1372493, FILED 11-16-2007, REG. NO. TMA783811, DATED 12-1-2010, EXPIRES 12-1-2025.

OWNER OF U.S. REG. NOS. 1,916,334, 2,643,808 AND OTHERS.

FOR WATER TREATMENT EQUIPMENT FOR INDUSTRIAL, COMMERCIAL, AND MUNICIPAL USE, NAMELY, A UV REACTOR FOR DISINFECTION OF WASTEWATER AND OTHER FLUIDS (U.S. CLS. 13, 21, 23, 31 AND 34).

LESLIE RICHARDS, EXAMINING ATTORNEY

**CLASS 11—(Continued).**

SN 77-725,726. FLANDERS CORPORATION, WASHINGTON, NC. FILED 4-30-2009.

**FLANDERS / AIR SEAL**

THE MARK CONSISTS OF STANDARD CHARACTERS WITHOUT CLAIM TO ANY PARTICULAR FONT, STYLE, SIZE, OR COLOR.

OWNER OF U.S. REG. NOS. 2,325,356, 2,331,137 AND 3,105,404.

SEC. 2(F).

FOR AIR CLEANING HOUSINGS, NAMELY, HOUSINGS CONTAINING AIR HANDLING UNITS, AIR FILTRATION UNITS, AIR SCRUBBER UNITS AND COMBINATIONS THEREOF (U.S. CLS. 13, 21, 23, 31 AND 34).

FIRST USE 6-0-1996; IN COMMERCE 6-0-1996.

PRISCILLA MILTON, EXAMINING ATTORNEY

SN 77-775,654. LG ELECTRONICS INC., SEOUL, REPUBLIC OF KOREA, FILED 7-7-2009.

**EZ Steel**

THE MARK CONSISTS OF STANDARD CHARACTERS WITHOUT CLAIM TO ANY PARTICULAR FONT, STYLE, SIZE, OR COLOR.

PRIORITY CLAIMED UNDER SEC. 44(D) ON REPUBLIC OF KOREA APPLICATION NO. 2009-0031530, FILED 7-3-2009, REG. NO. 0834539, DATED 8-30-2010, EXPIRES 8-30-2020.

NO CLAIM IS MADE TO THE EXCLUSIVE RIGHT TO USE "STEEL", APART FROM THE MARK AS SHOWN.

FOR ELECTRIC REFRIGERATORS; REFRIGERATORS FOR KIMCHI; ELECTRIC COOKING OVENS INCORPORATING LIGHT WAVES; TEMPERATURE CONTROLLED ELECTRIC WINE CELLARS; ELECTRIC COOKING AND TOASTER OVENS; ELECTRIC FREEZERS; ELECTRIC LAUNDRY DRYERS; MICROWAVE RANGES; ELECTRIC RANGES FOR HOUSEHOLD USE; AIR PURIFIERS; AIR CONDITIONERS; HOT AIR SPACE HEATING APPARATUS; HUMIDIFIERS; ELECTRIC DEHUMIDIFIER FOR HOUSEHOLD USE; DISH DISINFECTANT APPARATUS FOR HOUSEHOLD PURPOSES; WATER PURIFIERS FOR HOUSEHOLD PURPOSES; ELECTRIC WATER PURIFIERS FOR HOUSEHOLD USE; WATER IONIZERS; WATER PURIFYING APPARATUS; ELECTRIC FOOTWARMERS (U.S. CLS. 13, 21, 23, 31 AND 34).

JASON BLAIR, EXAMINING ATTORNEY

**CLASS 11—(Continued).**

SN 77-820,483. AMG (QLD) PTY LTD, COOMERA, AUSTRALIA, FILED 9-4-2009.

**AQUALUMA**

THE MARK CONSISTS OF STANDARD CHARACTERS WITHOUT CLAIM TO ANY PARTICULAR FONT, STYLE, SIZE, OR COLOR.

OWNER OF AUSTRALIA REG. NO. 1127049, DATED 8-1-2006, EXPIRES 8-1-2016.

FOR UNDERWATER SEARCH LIGHTS FOR USE ON BOATS ON HULL SURFACE MOUNTS; HIGH INTENSITY SEARCH LIGHTS SPECIFICALLY FOR USE ON BOATS; UNDERWATER SPREADER LIGHTS AND, SUBMERSIBLE TRIM TAIL LIGHTS, SPECIFICALLY FOR USE ON BOATS; SUBMERSIBLE DOCK LIGHTS (U.S. CLS. 13, 21, 23, 31 AND 34).

JOHN DALIER, EXAMINING ATTORNEY

SN 77-821,235. JOHN G. SOLOMON, VICKSBURG, MS. FILED 9-7-2009.



*Ibis & Orchid Design, Inc.*

NO CLAIM IS MADE TO THE EXCLUSIVE RIGHT TO USE "DESIGN, INC.", APART FROM THE MARK AS SHOWN.

THE MARK CONSISTS OF AN OVAL CONTAINING AN IBIS BIRD, ORCHID, AND GRASSES IN A LAKE. BELOW THE OVAL IS THE WORDING "IBIS & ORCHID DESIGN, INC."

FOR ELECTRIC NIGHT LIGHTS (U.S. CLS. 13, 21, 23, 31 AND 34).

FIRST USE 2-1-2000; IN COMMERCE 7-1-2000.

ALLISON SCHRODY, EXAMINING ATTORNEY

SN 77-869,802. PC MARKETING, INC., RIDGEFIELD, NJ. FILED 11-10-2009.

**iSun**

THE MARK CONSISTS OF STANDARD CHARACTERS WITHOUT CLAIM TO ANY PARTICULAR FONT, STYLE, SIZE, OR COLOR.

FOR TANNING BEDS AND PARTS THEREFOR SOLD TOGETHER AS A UNIT (U.S. CLS. 13, 21, 23, 31 AND 34).

NICHOLAS ALTREE, EXAMINING ATTORNEY



**CLASS 11—(Continued).**

SN 79-080,869. NORDIC WATER PRODUCTS AB, SE-431 32 VÄSTRA FRÖLUNDA, SWEDEN, FILED 1-7-2010.

# DYNAAIR

THE MARK CONSISTS OF STANDARD CHARACTERS WITHOUT CLAIM TO ANY PARTICULAR FONT, STYLE, SIZE, OR COLOR.

OWNER OF INTERNATIONAL REGISTRATION 1031910 DATED 1-7-2010, EXPIRES 1-7-2020.

FOR AIR SUPPLY SYSTEMS FOR GRANULAR BED FILTERS, FOR USE IN WATER AND WASTE WATER TREATMENT, CONSISTING PRIMARILY OF COMPRESSORS WITH SPEED CONTROL AND COMPRESSORS WITH AIR COOLING AND CONDENSATE REMOVING FUNCTION USED WITH HEAT EXCHANGERS (U.S. CLS. 13, 21, 23, 31 AND 34).

TINA BROWN, EXAMINING ATTORNEY

SN 79-084,186. KONINKLIJKE PHILIPS ELECTRONICS N.V., NL-5621 BA EINDHOVEN, NETHERLANDS, FILED 5-21-2010.

# LivingWhites

THE MARK CONSISTS OF STANDARD CHARACTERS WITHOUT CLAIM TO ANY PARTICULAR FONT, STYLE, SIZE, OR COLOR.

PRIORITY DATE OF 12-4-2009 IS CLAIMED.

OWNER OF INTERNATIONAL REGISTRATION 1043105 DATED 5-21-2010, EXPIRES 5-21-2020.

FOR ELECTRIC LAMPS, LIGHTING FIXTURES AND LIGHTING INSTALLATIONS; LIGHTING FIXTURES AND LIGHTING INSTALLATIONS FITTED WITH LED LIGHT SOURCES; PARTS OF THE AFORESAID GOODS (U.S. CLS. 13, 21, 23, 31 AND 34).

HELENE LIWINSKI, EXAMINING ATTORNEY

SN 79-084,278. KONINKLIJKE PHILIPS ELECTRONICS N.V., NL-5621 BA EINDHOVEN, NETHERLANDS, FILED 5-20-2010.

# ARCITONE

THE MARK CONSISTS OF STANDARD CHARACTERS WITHOUT CLAIM TO ANY PARTICULAR FONT, STYLE, SIZE, OR COLOR.

PRIORITY DATE OF 12-11-2009 IS CLAIMED.

OWNER OF INTERNATIONAL REGISTRATION 1043340 DATED 5-20-2010, EXPIRES 5-20-2020.

FOR ELECTRIC LAMPS, LIGHTING FIXTURES AND LIGHTING INSTALLATIONS; LIGHTING FIXTURES AND LIGHTING INSTALLATIONS FITTED WITH LED LIGHT SOURCES; PARTS OF THE AFORESAID GOODS (U.S. CLS. 13, 21, 23, 31 AND 34).

HELENE LIWINSKI, EXAMINING ATTORNEY

**CLASS 11—(Continued).**

SN 79-084,542. SVETLOBA D.O.O., SI-1370 LOGATEC, SLOVENIA, FILED 5-26-2010.



OWNER OF INTERNATIONAL REGISTRATION 1043908 DATED 5-26-2010, EXPIRES 5-26-2020.

NO CLAIM IS MADE TO THE EXCLUSIVE RIGHT TO USE "REFLECTA", APART FROM THE MARK AS SHOWN.

THE COLOR(S) BLACK, WHITE AND YELLOW IS/ARE CLAIMED AS A FEATURE OF THE MARK.

THE MARK CONSISTS OF A BLACK RECTANGLE UPON WHICH APPEARS THE WORDING "REFLECTA" IN A WHITE STYLIZED FONT, FOLLOWED BY THREE HORIZONTAL YELLOW LINES, ABOVE THE WORDING "ECOPOWERLIGHTS" IN A WHITE STYLIZED FONT.

THE ENGLISH TRANSLATION OF "REFLECTA" IN THE MARK IS "REFLECT".

FOR APPARATUS FOR LIGHTING, NAMELY, LIGHTING FIXTURES AND LIGHT BULBS, LAMPS, FLUORESCENT LAMPS, HIGH-EFFICIENT ENERGY LAMPS (U.S. CLS. 13, 21, 23, 31 AND 34).

JAMES MACFARLANE, EXAMINING ATTORNEY

SN 79-087,105. UGOLINI SPA, ITALY, FILED 6-11-2010.

# UGOLINI

THE MARK CONSISTS OF STANDARD CHARACTERS WITHOUT CLAIM TO ANY PARTICULAR FONT, STYLE, SIZE, OR COLOR.

PRIORITY DATE OF 5-24-2010 IS CLAIMED.

OWNER OF INTERNATIONAL REGISTRATION 1050460 DATED 6-11-2010, EXPIRES 6-11-2020.

OWNER OF U.S. REG. NO. 2,248,394. SEC. 2(F).

FOR TEMPERATURE-CONTROLLED FOOD AND BEVERAGE DISPENSERS, NAMELY, COLD DRINK DISPENSERS FOR ICED COFFEE, ICED CAPPUCCINO, COCKTAILS, FRUIT JUICES, MILK, AND ICE WATER; FROZEN DESSERT DISPENSERS FOR DISPENSING SORBET, YOGURT, GRANITA, ICE CREAM; JUICE DISPENSERS; HOT CHOCOLATE DISPENSERS; COFFEE AND CAPPUCCINO DISPENSERS, AND STRUCTURAL PARTS OF ALL AFOREMENTIONED GOODS (U.S. CLS. 13, 21, 23, 31 AND 34).

JESSICA FATHY, EXAMINING ATTORNEY

**CLASS 11—(Continued).**

SN 79-087,283. LM-THERM GMBH, 94501 ALDERSBACH, FED REP GERMANY, FILED 8-24-2010.

# Lm-therm

THE MARK CONSISTS OF STANDARD CHARACTERS WITHOUT CLAIM TO ANY PARTICULAR FONT, STYLE, SIZE, OR COLOR.

PRIORITY DATE OF 2-25-2010 IS CLAIMED.

OWNER OF INTERNATIONAL REGISTRATION 1050890 DATED 8-24-2010, EXPIRES 8-24-2020.

FOR HEATING APPARATUS, NAMELY, ELECTRIC HEATING APPARATUS FOR INDUSTRIAL USE; ELECTRIC SMALL HEATING APPARATUS FOR TECHNICAL PURPOSES, IN PARTICULAR FOR SWITCH CABINETS AND ELECTRICAL DEVICES; HEATING APPARATUS FOR SWITCH CABINETS; COOLING INSTALLATIONS AND COOLING APPARATUS, IN PARTICULAR FOR SWITCH CABINETS; VENTILATING INSTALLATIONS AND VENTILATING APPARATUS, IN PARTICULAR FOR SWITCH CABINETS; REGULATING INSTALLATIONS AND REGULATING APPARATUS FOR REGULATING TEMPERATURE AND AIR HUMIDITY, IN PARTICULAR FOR SWITCH CABINETS (U.S. CLS. 13, 21, 23, 31 AND 34).

KAREN SEVERSON, EXAMINING ATTORNEY

SN 79-087,342. INDUSTRIARMATUR-ARI AKTIEBOLAG, SE-411 04 GÖTEBORG, SWEDEN, FILED 4-6-2010.

# IA HECON

THE MARK CONSISTS OF STANDARD CHARACTERS WITHOUT CLAIM TO ANY PARTICULAR FONT, STYLE, SIZE, OR COLOR.

OWNER OF INTERNATIONAL REGISTRATION 1051024 DATED 4-6-2010, EXPIRES 4-6-2020.

OWNER OF U.S. REG. NO. 3,462,545.

FOR APPARATUS FOR MANEUVERING OF VALVES RELATING TO DISTRICT HEATING, DISTRICT COOLING, GAS AND WATER SUPPLY, NAMELY, REGULATING ACCESSORIES FOR WATER OR GAS APPARATUS AND PIPES FOR THE OPENING AND CLOSING OF VALVES PLACED UNDER SURFACE (U.S. CLS. 13, 21, 23, 31 AND 34).

ROBERT STRUCK, EXAMINING ATTORNEY

SN 85-024,350. LE ELEGANT BATH INC, DBA AMERICAN BATH FACTORY, CORONA, CA. FILED 4-27-2010.

# Champagne Massage

THE MARK CONSISTS OF STANDARD CHARACTERS WITHOUT CLAIM TO ANY PARTICULAR FONT, STYLE, SIZE, OR COLOR.

NO CLAIM IS MADE TO THE EXCLUSIVE RIGHT TO USE "MASSAGE", APART FROM THE MARK AS SHOWN.

FOR BATHS, BATHTUBS, WHIRLPOOL BATHS AND BATH INSTALLATIONS; BATHTUBS (U.S. CLS. 13, 21, 23, 31 AND 34).

FIRST USE 1-1-2002; IN COMMERCE 1-1-2002.

ELISSA GARBER KON, EXAMINING ATTORNEY

**CLASS 11—(Continued).**

SN 85-035,440. RINNAI AMERICA CORPORATION, PEACH-TREE CITY, GA. FILED 5-11-2010.

# bluegreen

THE MARK CONSISTS OF STANDARD CHARACTERS WITHOUT CLAIM TO ANY PARTICULAR FONT, STYLE, SIZE, OR COLOR.

FOR WATER HEATERS AND HEATING BOILERS, NOT OF BLUE GREEN COLOR (U.S. CLS. 13, 21, 23, 31 AND 34).

FONG HSU, EXAMINING ATTORNEY

SN 85-053,429. DALLMER GMBH & CO KG, ARNSBERG, FED REP GERMANY, FILED 6-3-2010.

# Zentrix

THE MARK CONSISTS OF STANDARD CHARACTERS WITHOUT CLAIM TO ANY PARTICULAR FONT, STYLE, SIZE, OR COLOR.

OWNER OF ERPN CMNTY TM OFC REG. NO. 008939845, DATED 9-2-2010, EXPIRES 3-9-2020.

THE WORDING "ZENTRIX" HAS NO MEANING IN A FOREIGN LANGUAGE.

FOR (BASED ON INTENT TO USE) PLUMBING FITTINGS, NAMELY, FLOOR DRAIN FITTINGS; FLOOR DRAINS; SHOWER DRAINS; SHOWER DRAIN FITTINGS, AND PARTS THEREFOR (BASED ON 44(D) PRIORITY APPLICATION) PLUMBING FITTINGS, NAMELY, FLOOR DRAIN FITTINGS; FLOOR DRAINS; SHOWER DRAINS; SHOWER DRAIN FITTINGS, AND PARTS THEREFOR (U.S. CLS. 13, 21, 23, 31 AND 34).

LINDA ORNDORFF, EXAMINING ATTORNEY

SN 85-120,290. ADFINITUM DESIGNS, LLC, COLORADO SPRINGS, CO. FILED 8-31-2010.

# CARBONBLOW

THE MARK CONSISTS OF THE STYLIZED TEXT "CARBONBLOW".

FOR CARBON AIR FILTERS FOR DOMESTIC AND INDUSTRIAL INSTALLATIONS AND CARBON FILTER VENTILATING EXHAUST FANS FOR ODOR AND DUST CONTROL, AND FOR RESIDENTIAL AND COMMERCIAL USE (U.S. CLS. 13, 21, 23, 31 AND 34).

FIRST USE 5-1-2010; IN COMMERCE 11-1-2010.

JESSICA A. POWERS, EXAMINING ATTORNEY

**CLASS 11—(Continued).**

SN 85-148,509. SANS SOLEIL, LLC, BEVERLY HILLS, CA.  
FILED 10-8-2010.



FOR PORTABLE, HAND-HELD DEVICES FOR THE  
SPRAY-ON APPLICATION OF UV-FREE TANNING  
AND BEAUTY LOTIONS (U.S. CLS. 13, 21, 23, 31 AND  
34).

INGRID C. EULIN, EXAMINING ATTORNEY

SN 85-153,743. BURNABY, JOHN L, BUELLTON, CA. FILED  
10-15-2010.



THE MARK CONSISTS OF STANDARD CHARACTERS  
WITHOUT CLAIM TO ANY PARTICULAR FONT, STYLE,  
SIZE, OR COLOR.

THE WORDING "MATSANA" HAS NO MEANING IN A  
FOREIGN LANGUAGE.

FOR DISINFECTING ULTRAVIOLET LAMPS  
HOUSED IN A CONTAINER OR COVER FOR DISIN-  
FECTING OBJECTS PLACED THEREIN (U.S. CLS. 13, 21,  
23, 31 AND 34).

FIRST USE 9-12-2010; IN COMMERCE 9-12-2010.  
NAKIA HENRY, EXAMINING ATTORNEY

SN 85-155,992. HARTMAN DESIGN, INC., WERNERSVILLE,  
PA. FILED 10-19-2010.



THE MARK CONSISTS OF STANDARD CHARACTERS  
WITHOUT CLAIM TO ANY PARTICULAR FONT, STYLE,  
SIZE, OR COLOR.

NO CLAIM IS MADE TO THE EXCLUSIVE RIGHT TO  
USE "LIGHTING", APART FROM THE MARK AS SHOWN.

FOR ELECTRIC LIGHTING FIXTURES (U.S. CLS. 13,  
21, 23, 31 AND 34).

ANDREA K. NADELMAN, EXAMINING ATTORNEY

**CLASS 11—(Continued).**

SN 85-174,120. DAGOSTINO, GIOVANNI, WESTON, FL.  
FILED 11-10-2010.



THE MARK CONSISTS OF STANDARD CHARACTERS  
WITHOUT CLAIM TO ANY PARTICULAR FONT, STYLE,  
SIZE, OR COLOR.

THE WORDING "L'GABINET" HAS NO MEANING IN A  
FOREIGN LANGUAGE.

FOR SINK PEDESTALS; URINALS (U.S. CLS. 13, 21,  
23, 31 AND 34).

AMY C. KEAN, EXAMINING ATTORNEY

SN 85-174,592. HINKLEY LIGHTING, INC., CLEVELAND,  
OH. FILED 11-11-2010.



THE MARK CONSISTS OF STANDARD CHARACTERS  
WITHOUT CLAIM TO ANY PARTICULAR FONT, STYLE,  
SIZE, OR COLOR.

THE NAME(S), PORTRAIT(S), AND/OR SIGNATURE(S)  
SHOWN IN THE MARK DOES NOT IDENTIFY A PARTI-  
CULAR LIVING INDIVIDUAL.

FOR LIGHTING FIXTURES (U.S. CLS. 13, 21, 23, 31  
AND 34).

FIRST USE 12-31-1965; IN COMMERCE 12-31-1965.  
REBECCA EISINGER, EXAMINING ATTORNEY

SN 85-174,594. HINKLEY LIGHTING, INC., CLEVELAND,  
OH. FILED 11-11-2010.



THE MARK CONSISTS OF THE STYLIZED LETTERS "F"  
AND "R".

FOR LIGHTING FIXTURES (U.S. CLS. 13, 21, 23, 31  
AND 34).

FIRST USE 1-0-2008; IN COMMERCE 1-0-2008.

REBECCA EISINGER, EXAMINING ATTORNEY

**CLASS 11—(Continued).**

SN 85-176,459. THE YANKEE CANDLE COMPANY, INC., SOUTH DEERFIELD, MA. FILED 11-15-2010.

**AUTUMN LEAVES**

THE MARK CONSISTS OF STANDARD CHARACTERS WITHOUT CLAIM TO ANY PARTICULAR FONT, STYLE, SIZE, OR COLOR.

FOR ELECTRIC AIR FRESHENER FRAGRANCE DISPENSERS; REED DIFFUSERS FOR SCENTED OILS (U.S. CLS. 13, 21, 23, 31 AND 34).

FIRST USE 6-4-2008; IN COMMERCE 6-4-2008.  
HANNO RITTNER, EXAMINING ATTORNEY

**CLASS 11—(Continued).**

SN 85-177,585. CMG ENERGY SOLUTIONS, LLC, WATER-TOWN, WI. FILED 11-16-2010.

**Power in Light**

THE MARK CONSISTS OF STANDARD CHARACTERS WITHOUT CLAIM TO ANY PARTICULAR FONT, STYLE, SIZE, OR COLOR.

FOR LED LIGHT BULBS (U.S. CLS. 13, 21, 23, 31 AND 34).

FIRST USE 6-18-2010; IN COMMERCE 9-3-2010.  
COLLEEN KEARNEY, EXAMINING ATTORNEY

SN 85-177,524. GROUPE LCX, LE MANS, FRANCE, FILED 11-16-2010.



OWNER OF FRANCE REG. NO. 073525585, DATED 9-20-2007, EXPIRES 9-20-2017.

OWNER OF U.S. REG. NO. 3,697,548.

THE COLOR(S) RED, BLACK AND WHITE IS/ARE CLAIMED AS A FEATURE OF THE MARK.

THE MARK CONSISTS OF A RED CIRCLE IN THE UPPER RIGHT SIDE OF THE MARK WITH THE TOP AND FAR RIGHT SIDES OF THE CIRCLE NOT SHOWING. TWO WHITE WAVY DIAGONAL LINES THAT INTERSECT ARE PLACED PARTIALLY OVER THE INCOMPLETE RED CIRCLE AND THE TERM "LEBLANC" IS PRESENTED IN WHITE AND APPEARING UNDER THE DESIGN. THE MARK HAS A BLACK RECTANGLE SERVING AS THE BACKGROUND.

FOR ILLUMINATING APPARATUS, NAMELY, ELECTRIC LUMINOUS DECORATIONS, NAMELY, ELECTRIC LIGHT DECORATIVE STRINGS, DECORATIVE LAMPS; ELECTRIC STREET DECORATIONS, NAMELY, ELECTRIC HOLIDAY LIGHTS; LANDSCAPE LIGHTING INSTALLATIONS; LIGHTING FIXTURES AND ASSEMBLIES FOR USE IN DISPLAY, COMMERCIAL, INDUSTRIAL, RESIDENTIAL, AND ARCHITECTURAL ACCENT LIGHTING APPLICATIONS; ELECTRIC LIGHT DECORATIVE STRINGS; DECORATIVE LIGHTING FIXTURES; DECORATIVE ELECTRIC LIGHT BULBS; ELECTRIC HOLIDAY LIGHTS; ELECTRIC NIGHT LIGHTS; ELECTRIC LIGHTS FOR CHRISTMAS TREES; OUTDOOR LIGHTED HOLIDAY ORNAMENTS; ELECTRIC CHINESE LANTERNS (U.S. CLS. 13, 21, 23, 31 AND 34).

TRACY WHITTAKER-BROWN, EXAMINING ATTORNEY

SN 85-178,730. FRIMONT S.P.A., POGLIANO MILAN, ITALY, FILED 11-17-2010.

**FRIMONT**

THE MARK CONSISTS OF STANDARD CHARACTERS WITHOUT CLAIM TO ANY PARTICULAR FONT, STYLE, SIZE, OR COLOR.

FOR REFRIGERATING APPARATUSES, NAMELY, REFRIGERATORS AND FREEZERS; ICE CUBE MAKING AND DISPENSING MACHINES AND STRUCTURAL PARTS FOR AFORESAID GOODS (U.S. CLS. 13, 21, 23, 31 AND 34).

ZACHARY BELLO, EXAMINING ATTORNEY

SN 85-179,233. AKCES MEDIA LLC, DBA ALZO DIGITAL, BETHEL, CT. FILED 11-17-2010.

**Joyous Light**

THE MARK CONSISTS OF STANDARD CHARACTERS WITHOUT CLAIM TO ANY PARTICULAR FONT, STYLE, SIZE, OR COLOR.

FOR FLUORESCENT ELECTRIC LIGHT BULBS (U.S. CLS. 13, 21, 23, 31 AND 34).

FIRST USE 11-1-2010; IN COMMERCE 11-1-2010.  
BRENDAN REGAN, EXAMINING ATTORNEY

**CLASS 11—(Continued).**

SN 85-179,373. KIRK D. WILLIAMSON, LINDON, UT. FILED 11-17-2010.

# TYVARIAN

THE MARK CONSISTS OF STANDARD CHARACTERS WITHOUT CLAIM TO ANY PARTICULAR FONT, STYLE, SIZE, OR COLOR.

FOR WHIRLPOOL TUBS, SPAS IN THE NATURE OF HEATED POOLS, BATHTUBS, SHOWERS, SHOWER DOORS, BATH AND SHOWER SURROUNDS, AND KITCHEN SINKS (U.S. CLS. 13, 21, 23, 31 AND 34).

FIRST USE 8-31-2008; IN COMMERCE 8-31-2008.  
DOMINIC J. FERRAIUOLO, EXAMINING ATTORNEY

**CLASS 11—(Continued).**

SN 85-180,514. TRAEGER PELLET GRILLS LLC, WILSONVILLE, OR. FILED 11-18-2010.

# TASTE THE DIFFERENCE

THE MARK CONSISTS OF STANDARD CHARACTERS WITHOUT CLAIM TO ANY PARTICULAR FONT, STYLE, SIZE, OR COLOR.

OWNER OF U.S. REG. NO. 3,289,659.  
FOR BARBECUE SMOKERS (U.S. CLS. 13, 21, 23, 31 AND 34).

ANTHONY RINKER, EXAMINING ATTORNEY

SN 85-180,173. BAHNSON, INC., WINSTON-SALEM, NC. FILED 11-18-2010.

# BahnsoneAire

THE MARK CONSISTS OF THE LITERAL ELEMENT "BAHNSONAIRE" WRITTEN IN BRUSH SCRIPT MT FONT.

FOR INDUSTRIAL ELECTRIC OSCILLATING FANS FOR AUTOMATIC CLEANING OF CEILINGS, LIGHT FIXTURES, DUCTS AND OTHER OVERHEAD STRUCTURES EXPOSED TO FIBROUS AIRBORNE CONTAMINANTS (U.S. CLS. 13, 21, 23, 31 AND 34).

SUSAN LESLIE DUBOIS, EXAMINING ATTORNEY

SN 85-200,289. THE DOW CHEMICAL COMPANY, MIDLAND, MI. FILED 12-17-2010.

# HYPERSHELL

THE MARK CONSISTS OF STANDARD CHARACTERS WITHOUT CLAIM TO ANY PARTICULAR FONT, STYLE, SIZE, OR COLOR.

OWNER OF U.S. REG. NO. 2,833,610.  
FOR WATER FILTERS AND MEMBRANES FOR WATER PURIFICATION SYSTEMS (U.S. CLS. 13, 21, 23, 31 AND 34).

JAY BESCH, EXAMINING ATTORNEY

SN 85-180,342. HOBBY LOBBY STORES, INC., OKLAHOMA CITY, OK. FILED 11-18-2010.

# TOUCH OF LIGHT

THE MARK CONSISTS OF STANDARD CHARACTERS WITHOUT CLAIM TO ANY PARTICULAR FONT, STYLE, SIZE, OR COLOR.

FOR LIGHTED PARTY-THEMED DECORATIONS, ELECTRIC LIGHT DECORATIVE STRINGS (U.S. CLS. 13, 21, 23, 31 AND 34).

DEIRDRE ROBERTSON, EXAMINING ATTORNEY

SN 85-201,654. IBEX DENTAL TECHNOLOGIES, RICHARDSON, TX. FILED 12-20-2010.

# SUMMIT

THE MARK CONSISTS OF STANDARD CHARACTERS WITHOUT CLAIM TO ANY PARTICULAR FONT, STYLE, SIZE, OR COLOR.

FOR DENTAL OVENS (U.S. CLS. 13, 21, 23, 31 AND 34).

FIRST USE 2-25-2010; IN COMMERCE 2-25-2010.  
BRIDGETT SMITH, EXAMINING ATTORNEY

**CLASS 12—VEHICLES**

SN 76-702,376. LGS INDUSTRIES, INC., BRISTOL, IN. FILED 4-5-2010.

**LOOK**

THE MARK CONSISTS OF STANDARD CHARACTERS WITHOUT CLAIM TO ANY PARTICULAR FONT, STYLE, SIZE, OR COLOR.

FOR TRAILERS FOR SPORT AND PERSONAL USE, NAMELY, CARGO TRAILERS WHICH ARE TOWED BY AUTOMOBILES OR TRUCKS (U.S. CLS. 19, 21, 23, 31, 35 AND 44).

DANIEL CAPSHAW, EXAMINING ATTORNEY

**CLASS 12—(Continued).**

SN 77-860,794. ELECTRONIC CONTROLS COMPANY, BOISE, ID. FILED 10-29-2009.

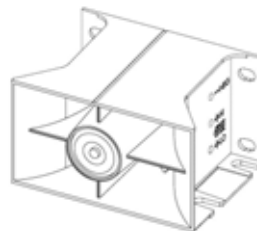

OWNER OF U.S. REG. NOS. 2,915,640, 3,003,235 AND OTHERS.

THE MARK CONSISTS OF A THREE-DIMENSIONAL PRODUCT CONFIGURATION COMPRISED OF THE FRONT VIEW OF A HOUSING WITH FRONT-FACING HORIZONTAL, VERTICAL AND CIRCULAR ELEMENTS. THE DOTTED LINES ARE INTENDED TO SHOW POSITION OF THE MARK ON THE GOODS AND ARE NOT PART OF THE MARK.

SEC. 2(F).

FOR BACK-UP WARNING ALARMS FOR VEHICLES (U.S. CLS. 19, 21, 23, 31, 35 AND 44).

FIRST USE 12-0-1993; IN COMMERCE 12-0-1993.

LINDA M. KING, EXAMINING ATTORNEY

SN 77-886,091. STREET SURFING LLC, LAS VEGAS, NV. FILED 12-4-2009.

**STREET SURFING**

THE MARK CONSISTS OF STANDARD CHARACTERS WITHOUT CLAIM TO ANY PARTICULAR FONT, STYLE, SIZE, OR COLOR.

FOR SCOOTERS (U.S. CLS. 19, 21, 23, 31, 35 AND 44).

ANDREA BUTLER, EXAMINING ATTORNEY

SN 77-860,687. ELECTRONIC CONTROLS COMPANY, BOISE, ID. FILED 10-29-2009.

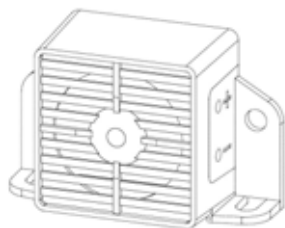

OWNER OF U.S. REG. NOS. 2,915,640, 3,003,235 AND OTHERS.

THE MARK CONSISTS OF THE FRONT PANEL OF A THREE-DIMENSIONAL PRODUCT CONFIGURATION. THE FRONT PANEL BEARS HORIZONTAL, VERTICAL AND CIRCULAR ELEMENTS. THE DOTTED LINES ARE INTENDED TO SHOW POSITION OF THE MARK ON THE GOODS AND ARE NOT PART OF THE MARK.

SEC. 2(F).

FOR BACK-UP WARNING ALARMS FOR VEHICLES (U.S. CLS. 19, 21, 23, 31, 35 AND 44).

FIRST USE 12-0-1993; IN COMMERCE 12-0-1993.

LINDA M. KING, EXAMINING ATTORNEY

SN 77-956,121. PHILBERT, MCGAVY K., MIAMI, FL. FILED 3-11-2010.



NO CLAIM IS MADE TO THE EXCLUSIVE RIGHT TO USE "AUTO" OR "INC.", APART FROM THE MARK AS SHOWN.

THE COLOR(S) BLACK, DARK SILVER, BROWN, MEDIUM SILVER, AND LIGHT SILVER IS/ARE CLAIMED AS A FEATURE OF THE MARK.

THE MARK CONSISTS OF THE STYLIZED WORDING "GLEXXOTIC AUTO FLAVOR INC. ADD ZEST TO YOUR RIDE" SET INSIDE A SMALL RECTANGLE WITH SCREWS

**CLASS 12—(Continued).**

AT EACH OF THE CORNERS, ALL SUPERIMPOSED OVER A LARGER RECTANGLE FEATURING A REPEATED PATTERN OF SHORT, SLIGHTLY BOWED LINES, SO AS TO APPEAR TO BE A STYLIZED METAL PLATE WITH A STAMPED DESIGN. THE COLOR BLACK APPEARS IN THE WORDING "GLEZZOTIC AUTO FLAVOR INC. ADD ZEST TO YOUR RIDE" AND IN THE DARKEST AREAS OF THE REPEATED PATTERN ON THE LARGER RECTANGLE; THE COLOR DARK SILVER APPEARS IN THE DARKEST AREAS OF THE SCREWS, IN THE SECOND DARKEST AREAS OF THE REPEATED PATTERN ON THE LARGER RECTANGLE, AND THE DARKEST AREAS OF THE BACKGROUND OF THE LARGER RECTANGLE; THE COLOR BROWN APPEARS IN THE IN THE THIRD DARKEST AREAS OF THE REPEATED PATTERN ON THE LARGER RECTANGLE AND THE SECOND DARKEST AREAS OF THE BACKGROUND OF THE LARGER RECTANGLE; THE COLOR MEDIUM SILVER APPEARS IN THE BACKGROUND OF THE SMALL RECTANGLE WITH SCREWS AT EACH CORNER, IN THE LIGHTER AREAS OF THE SCREWS, IN THE FOURTH DARKEST AREAS OF THE REPEATED PATTERN ON THE LARGER RECTANGLE, AND IN THE THIRD DARKEST AREAS OF THE BACKGROUND OF THE LARGER RECTANGLE; THE COLOR LIGHT SILVER APPEARS IN THE LIGHTEST AREAS OF THE REPEATED PATTERN ON THE LARGER RECTANGLE AND THE LIGHTEST AREAS OF THE BACKGROUND OF THE LARGER RECTANGLE.

FOR SPOILERS FOR VEHICLES; VEHICLE HOOD AND FENDER LOUVERS AND VENTS (U.S. CLS. 19, 21, 23, 31, 35 AND 44).

MICHAEL GAAFAR, EXAMINING ATTORNEY

SN 79-081,056. KUNSHAN GIANT; LIGHT METAL TECHNOLOGY CO., LTD., CHINA, FILED 3-15-2010.

**GLMAGIC**

OWNER OF INTERNATIONAL REGISTRATION 1034653 DATED 3-15-2010, EXPIRES 3-15-2020.

THE MARK CONSISTS OF THE STYLIZED WORDING "GLMAGIC" WITH THE LETTERS "GLM" IN SOLID LINES AND THE LETTERS "AGIC" IN STRIPES.

FOR ELECTRIC BICYCLES; MOTORCYCLE WHEELS; HUBS FOR MOTORCYCLE WHEELS; MOTORCYCLES; BICYCLES; BICYCLE STANDS; BICYCLE HANDLE BARS; BICYCLE RIMS; CRANKS FOR BICYCLES; WHEEL HUBS FOR BICYCLES; HAND CARS, NAMELY, CARTS; BABY CARRIAGES; BICYCLE TIRES; BICYCLE SPOKES; BICYCLE FRAMES; VEHICLE WHEELS (U.S. CLS. 19, 21, 23, 31, 35 AND 44).

KIMBERLY FRYE, EXAMINING ATTORNEY

SN 79-081,276. KUNSHAN GIANT; LIGHT METAL TECHNOLOGY CO., LTD., CHINA, FILED 3-15-2010.

**MAXGLM**

OWNER OF INTERNATIONAL REGISTRATION 1035299 DATED 3-15-2010, EXPIRES 3-15-2020.

THE MARK CONSISTS OF THE STYLIZED WORDING "MAXGLM" APPEARING ON A SOLID RECTANGULAR BACKGROUND.

FOR ELECTRIC BICYCLES; MOTORCYCLE WHEELS; HUBS FOR MOTORCYCLE WHEELS; MOTORCYCLES; BICYCLES; BICYCLE STANDS; BICYCLE HANDLE BARS; BICYCLE RIMS; CRANKS FOR BICYCLES; WHEEL HUBS FOR BICYCLES; HAND CARS, NAMELY, CARTS; BABY CARRIAGES; BICYCLE TIRES; BICYCLE SPOKES; BICYCLE FRAMES; VEHICLE WHEELS (U.S. CLS. 19, 21, 23, 31, 35 AND 44).

KIMBERLY FRYE, EXAMINING ATTORNEY

**CLASS 12—(Continued).**

SN 79-082,316. PAUL FREDDY RAVNBORG, SPAIN, FILED 3-15-2010.

## The "Shopping-Mate" System

PRIORITY DATE OF 10-2-2009 IS CLAIMED.  
OWNER OF INTERNATIONAL REGISTRATION 1037979 DATED 3-15-2010, EXPIRES 3-15-2020.

FOR SHOPPING CARTS (U.S. CLS. 19, 21, 23, 31, 35 AND 44).

RAUL CORDOVA, EXAMINING ATTORNEY

SN 79-084,350. XIAMEN YIHONG; GROUP INVESTMENT LIMITED COMPANY, XIAMEN, FUJIAN, CHINA, FILED 4-1-2010.



OWNER OF INTERNATIONAL REGISTRATION 1016313 DATED 8-6-2009, EXPIRES 8-6-2019.

THE STIPLING IS A FEATURE OF THE MARK AND DOES NOT INDICATE COLOR.

THE MARK CONSISTS OF A SHIELD DESIGN WITH THE GREEK LETTER PSI THEREON, WITH STYLIZED WINGS ON EACH SIDE OF THE SHIELD.

FOR RECREATIONAL VEHICLES, NAMELY, CAMPER; MOTOR HOMES; UPHOLSTERY FOR VEHICLES; AUTOMOBILES; BACK-UP WARNING ALARMS FOR VEHICLES; ANTI-THEFT DEVICES FOR MOTOR CARS; WHEELS OF AUTOMOBILES; BOATS; CHASSIS FOR MOTOR VEHICLES; ALL-TERRAIN VEHICLES (U.S. CLS. 19, 21, 23, 31, 35 AND 44).

ADA HAN, EXAMINING ATTORNEY

SN 85-005,674. BENSHMUEL, MARK, MIAMI, FL. FILED 4-3-2010.

**GROW GREEN**

THE MARK CONSISTS OF STANDARD CHARACTERS WITHOUT CLAIM TO ANY PARTICULAR FONT, STYLE, SIZE, OR COLOR.

NO CLAIM IS MADE TO THE EXCLUSIVE RIGHT TO USE "GREEN", APART FROM THE MARK AS SHOWN.

FOR RETAIL AND ONLINE STORE SERVICES FEATURING SUPPLIES FOR INDOOR HYDROPONIC SYSTEMS, LIGHTING SYSTEMS, FLUIDS FOR USE IN HYDROPONIC SYSTEMS, AND HYDROPONIC SYSTEMS (U.S. CLS. 19, 21, 23, 31, 35 AND 44).

ELLEN PERKINS, EXAMINING ATTORNEY

**CLASS 12—(Continued).**

SN 85-024,988. THOR TECH, INC., JACKSON CENTER, OH.  
FILED 4-28-2010.

# VOLTAGE

THE MARK CONSISTS OF STANDARD CHARACTERS WITHOUT CLAIM TO ANY PARTICULAR FONT, STYLE, SIZE, OR COLOR.

FOR RECREATIONAL VEHICLES, NAMELY, TRAVEL TRAILERS, FIFTH WHEEL TRAILERS AND SPORT UTILITY TRAILERS (U.S. CLS. 19, 21, 23, 31, 35 AND 44).  
WARREN L. OLANDRIA, EXAMINING ATTORNEY

SN 85-061,342. ALEXANDER DENNIS LIMITED, EDINBURGH MIDLOTHIAN, SCOTLAND, FILED 6-12-2010.

# ENVIRO 400

THE MARK CONSISTS OF STANDARD CHARACTERS WITHOUT CLAIM TO ANY PARTICULAR FONT, STYLE, SIZE, OR COLOR.

OWNER OF UNITED KINGDOM REG. NO. 2391979, DATED 11-11-2005, EXPIRES 5-14-2015.

OWNER OF U.S. REG. NOS. 2,864,741 AND 3,177,654.  
FOR LAND VEHICLES; BUSES; COACHES; VEHICLES FOR USE IN REFUSE COLLECTION AND DISPOSAL; STRUCTURAL PARTS FOR VEHICLES; CHASSIS AND VEHICLE SUB-FRAMES (U.S. CLS. 19, 21, 23, 31, 35 AND 44).  
DAVID ELTON, EXAMINING ATTORNEY

SN 85-081,658. TBC TRADEMARKS, LLC, LAS VEGAS, NV.  
FILED 7-9-2010.

# SPORT CLAW ATZ

THE MARK CONSISTS OF STANDARD CHARACTERS WITHOUT CLAIM TO ANY PARTICULAR FONT, STYLE, SIZE, OR COLOR.

NO CLAIM IS MADE TO THE EXCLUSIVE RIGHT TO USE "SPORT", APART FROM THE MARK AS SHOWN.  
FOR TIRES (U.S. CLS. 19, 21, 23, 31, 35 AND 44).  
B. PARADEWELAI, EXAMINING ATTORNEY

**CLASS 12—(Continued).**

SN 85-140,432. TRI-STAR TIRE GROUP, LLC, TOLUCA LAKE, CA. FILED 9-28-2010.

# Arista Tire

THE MARK CONSISTS OF STANDARD CHARACTERS WITHOUT CLAIM TO ANY PARTICULAR FONT, STYLE, SIZE, OR COLOR.

NO CLAIM IS MADE TO THE EXCLUSIVE RIGHT TO USE "TIRE", APART FROM THE MARK AS SHOWN.  
FOR TIRES (U.S. CLS. 19, 21, 23, 31, 35 AND 44).  
WON TEAK OH, EXAMINING ATTORNEY

SN 85-145,848. OBX BOATWORKS LLC, DBA OBX BOATWORKS, HIGH POINT, NC. FILED 10-5-2010.

# OBX Boatworks

THE MARK CONSISTS OF STANDARD CHARACTERS WITHOUT CLAIM TO ANY PARTICULAR FONT, STYLE, SIZE, OR COLOR.

NO CLAIM IS MADE TO THE EXCLUSIVE RIGHT TO USE "BOATWORKS", APART FROM THE MARK AS SHOWN.

FOR BOAT HULLS; BOATS AND STRUCTURAL PARTS THEREFOR; FISHING BOATS (U.S. CLS. 19, 21, 23, 31, 35 AND 44).  
FRED CARL, EXAMINING ATTORNEY

SN 85-151,091. EXPERT AUTO ENGINEERS, INC., PLEASANTON, CA. FILED 10-12-2010.



THE STIPPLING IS FOR SHADING PURPOSES ONLY.  
THE MARK CONSISTS OF THE STYLIZED WORDING "EXPERTPARTS" WRITTEN ON THE LOWER PORTION OF A RECTANGULAR BACKGROUND WITH ROUNDED EDGES AND A THICK, CURVED TRIM. BENEATH THE "EXP" IN "EXPERTPARTS" IS A CURVED LINE THAT FOLLOWS THE ROUNDED EDGES OF THE RECTANGULAR BACKGROUND.

FOR STEERING AND SUSPENSION SYSTEMS AND PARTS FOR STEERING AND SUSPENSION SYSTEMS FOR VEHICLES, NAMELY, UPPER BALL JOINTS, LOWER BALL JOINTS, BALL JOINTS WITH CONTROL ARMS, BUSHING KITS, INNER TIE ROD ENDS, OUTER TIE ROD ENDS, SLEEVES, IDLER ARMS, CENTER LINKS, STABILIZER KITS, INNER SOCKETS AND PITMAN ARMS (U.S. CLS. 19, 21, 23, 31, 35 AND 44).  
FIRST USE 8-25-2002; IN COMMERCE 8-25-2002.

MARCIE MILONE, EXAMINING ATTORNEY



**CLASS 12—(Continued).**

SN 85-151,876. CHRYSLER GROUP LLC, AUBURN HILLS, MI. FILED 10-13-2010.



OWNER OF U.S. REG. NOS. 1,870,470 AND 2,760,226.  
THE MARK CONSISTS OF SHIELD DESIGN SURROUNDING DEPICTION OF A "SNAKE HEAD".  
FOR MOTOR VEHICLES, NAMELY, PASSENGER AUTOMOBILES, THEIR STRUCTURAL PARTS, TRIM AND BADGES (U.S. CLS. 19, 21, 23, 31, 35 AND 44).  
ELISSA GARBER KON, EXAMINING ATTORNEY

**CLASS 12—(Continued).**

SN 85-162,363. CLASSIC INDUSTRIAL DESIGN LTD., BUR-NABY, BC, CANADA, FILED 10-27-2010.

**BRAHMA**

THE MARK CONSISTS OF STANDARD CHARACTERS WITHOUT CLAIM TO ANY PARTICULAR FONT, STYLE, SIZE, OR COLOR.  
PRIORITY CLAIMED UNDER SEC. 44(D) ON CANADA APPLICATION NO. 1,485,321, FILED 6-16-2010.  
FOR IMMOBILIZING DEVICES FOR VEHICLES, NAMELY, WHEEL LOCK BOOTS (U.S. CLS. 19, 21, 23, 31, 35 AND 44).  
ALEX KEAM, EXAMINING ATTORNEY

SN 85-174,625. SCAT ENTERPRISES, INC., REDONDO BEACH, CA. FILED 11-11-2010.

SN 85-152,525. MEADE, TOM, DBA THOMASSIMA CARS, LOS ANGELES, CA. FILED 10-14-2010.



THE COLOR(S) RED, YELLOW AND BROWN IS/ARE CLAIMED AS A FEATURE OF THE MARK.  
THE MARK CONSISTS OF A RED TEARDROP CONTAINING A YELLOW HOOFED ANIMAL WITH THE WINGS OF AN EAGLE AND THE BODY OF A GAZELLE WITH SMALL METALLIC ARMOR PLATES SIMILAR TO THE SCALES OF A REPTILE ON THE BACK, SIDES AND CHEST, AND THE HEAD OF A WOLF WITH THE HORNS OF A GAZELLE. BELOW THE TEARDROP IS A BROWN CURVED BANNER, OUTLINED IN YELLOW, WITH THE YELLOW STYLIZED TEXT "THOMASSIMA".  
FOR AUTOMOBILES AND STRUCTURAL PARTS THEREFOR (U.S. CLS. 19, 21, 23, 31, 35 AND 44).  
JAMES A. RAUEN, EXAMINING ATTORNEY



OWNER OF U.S. REG. NOS. 3,217,216 AND 3,222,015.  
THE MARK CONSISTS OF THE TERM "SCAT" PRESENTED IN FANCIFUL LETTERING.  
FOR VEHICLE SEATS; CUSTOM VEHICLE SEATS; VEHICLE BUCKET SEATS; VEHICLE RACING SEATS; VEHICLE SPORT SEATS; AUTOMOTIVE AFTERMARKET PARTS, NAMELY, SEATS; VEHICLE SEAT ACCESSORIES AND STRUCTURAL PARTS THEREFOR, NAMELY, SEAT COVERS, SEAT HARNESES, SEAT PADDING, AND SEAT ARMRESTS; AUTOMOTIVE SEAT KITS, NAMELY, FRONT SEAT, REAR SEAT, CONSOLES, SEAT COVERS, MAP POCKETS AND CASSETTE COMPARTMENTS; LAND VEHICLE INTERNAL COMBUSTION ENGINES; LAND VEHICLE COMPONENTS, NAMELY, CROSS BARS, FLEX PLATES, HEADLIGHT HOUSINGS, INTERIOR AND EXTERIOR DECORATIVE TRIM, MOLDINGS AND INSIGNIAS, SEDAN STRINGERS, SHOCK ABSORBING SPRINGS FOR MOTOR CARS, DIFFERENTIALS AND GEARS, CROSS DRIVE SHAFTS, SHIFT ROD COUPLERS, LOCK NUTS, AXLE BOOTS, BUS REAR MOTOR MOUNTS, HUBCAPS, GEAR SHIFTERS, STEERING WHEELS, PEDAL COVERS, PEDALS, GEAR SHIFTERS AND SHIFTER BOOTS, DOOR AND WINDOW HANDLES,

**CLASS 12—(Continued).**

WINDOW LOCKS, BRAKE HANDLES, VENT WINDOW FASTENERS, BUMPERS AND BUMPER BRACKETS, TORSION BARS, HOODS, HOOD HANDLES, ENGINE LID STAY SPRINGS, ENGINE COVERS, HORNS, FLOOR PANELS, OFF-ROAD SUSPENSION SYSTEMS, RUNNING BOARDS, RUBBER WINDOW MOLDING, BODY SEALS, BODY JACKETS, CAGES, TOW BARS, PULLEY AND BELT GUARDS, AIR INTAKE SCREENS, STEERING BRAKES, SPOILERS, SEATS, SEAT MOUNTING UNITS, SEAT CONTROLS, SEAT TRACKS, SEAT FRAMES, FOAM AS A COMPONENT PART OF A VEHICLE SEAT, SEAT TILT MECHANISMS, GEAR SHIFTER CONSOLES, UNDER DASH UTILITY TRAYS, SPEAKER SHELVES, SEAT COVERS, KNOBS FOR VEHICLE RADIOS AND HEATERS, RADIATOR FAN SHROUDS; AND FUEL LINES - ALL OF THE AFOREMENTIONED GOODS ONLY FOR THE PERFORMANCE AFTERMARKET FOR CARS, TRUCKS, AND AIRCRAFTS, SPECIFICALLY EXCLUDING THE AFTERMARKET FOR BOATS, CONSTRUCTION AND MINING MACHINERY (U.S. CLS. 19, 21, 23, 31, 35 AND 44).

FIRST USE 1-10-1968; IN COMMERCE 1-10-1968.  
DAWN FELDMAN, EXAMINING ATTORNEY

---

SN 85-176,730. DANIEL HECHTMAN, BUFFALO GROVE, IL. FILED 11-15-2010.

**SPARTACASE**

THE MARK CONSISTS OF STANDARD CHARACTERS WITHOUT CLAIM TO ANY PARTICULAR FONT, STYLE, SIZE, OR COLOR.

FOR VEHICLE SEAT COVERS (U.S. CLS. 19, 21, 23, 31, 35 AND 44).

C. DIONNE CLYBURN, EXAMINING ATTORNEY

---

SN 85-178,626. AFTERMARKET AUTO PARTS ALLIANCE, INC., SAN ANTONIO, TX. FILED 11-17-2010.

**ULTRA STOP**

THE MARK CONSISTS OF STANDARD CHARACTERS WITHOUT CLAIM TO ANY PARTICULAR FONT, STYLE, SIZE, OR COLOR.

FOR BRAKE PADS, BRAKE SHOES, AND BRAKE DRUMS AND ROTORS FOR LAND VEHICLES (U.S. CLS. 19, 21, 23, 31, 35 AND 44).

TEJBIR SINGH, EXAMINING ATTORNEY

**CLASS 12—(Continued).**

SN 85-179,455. QUZHOU XILE TRADEMARK & DESIGN CO., LTD., QUZHOU CITY, ZHEJIANG, CHINA, FILED 11-17-2010.



THE MARK CONSISTS OF A STYLIZED INDICATOR DIAL IN A CIRCULAR SHAPE WITH A LINE BISECTING IT FROM BOTTOM LEFT TO TOP RIGHT.

FOR AUTOMOBILES (U.S. CLS. 19, 21, 23, 31, 35 AND 44).

KATINA MISTER, EXAMINING ATTORNEY

---

SN 85-179,588. XIAMEN ASON PRODUCTS CO., LTD, XIAMEN, CHINA, FILED 11-18-2010.

**SWFTCARBN**

THE MARK CONSISTS OF STANDARD CHARACTERS WITHOUT CLAIM TO ANY PARTICULAR FONT, STYLE, SIZE, OR COLOR.

FOR BICYCLES; FRAMES FOR BICYCLES; HANDLE BARS FOR BICYCLES; RIMS FOR BICYCLE WHEELS; SADDLE COVERS FOR BICYCLES OR MOTORCYCLES; SADDLES FOR BICYCLES OR MOTORCYCLES; STANDS FOR BICYCLES; TIRES FOR BICYCLES; WHEELS FOR BICYCLES (U.S. CLS. 19, 21, 23, 31, 35 AND 44).

ELIZABETH KAJUBI, EXAMINING ATTORNEY

---

SN 85-183,366. TOYOTA JIDOSHA KABUSHIKI KAISHA, TA TOYOTA MOTOR CORPORATION, TOYOTA-SHI, AICHI-KEN, JAPAN, FILED 11-23-2010.

**HSD**

THE MARK CONSISTS OF STANDARD CHARACTERS WITHOUT CLAIM TO ANY PARTICULAR FONT, STYLE, SIZE, OR COLOR.

FOR AUTOMOBILES AND STRUCTURAL PARTS THEREOF, ENGINES FOR LAND VEHICLES (U.S. CLS. 19, 21, 23, 31, 35 AND 44).

LINDSEY RUBIN, EXAMINING ATTORNEY

**CLASS 12—(Continued).**

SN 85-183,807. ADVANTAGE INTERLOCK IID, INC., LAGUNA HILLS, CA. FILED 11-23-2010.

**LifeSafer of So. CA**

THE MARK CONSISTS OF STANDARD CHARACTERS WITHOUT CLAIM TO ANY PARTICULAR FONT, STYLE, SIZE, OR COLOR.

NO CLAIM IS MADE TO THE EXCLUSIVE RIGHT TO USE "SO. CA", APART FROM THE MARK AS SHOWN.

FOR ELECTRONIC DEVICES FOR DISABLING A VEHICLE IN RESPONSE TO A MEASUREMENT OF ALCOHOL IN EXCESS OF A SAFETY THRESHOLD IN THE BLOOD OF ITS PURPORTED OPERATOR (U.S. CLS. 19, 21, 23, 31, 35 AND 44).

FIRST USE 12-15-2009; IN COMMERCE 12-15-2009.  
JORDAN BAKER, EXAMINING ATTORNEY

---

SN 85-193,249. TOYOTA JIDOSHA KABUSHIKI KAISHA, TA TOYOTA MOTOR CORPORATION, TOYOTA-SHI, AICHIKEN, JAPAN, FILED 12-8-2010.

**ES300h**

THE MARK CONSISTS OF STANDARD CHARACTERS WITHOUT CLAIM TO ANY PARTICULAR FONT, STYLE, SIZE, OR COLOR.

FOR AUTOMOBILES AND STRUCTURAL PARTS THEREOF (U.S. CLS. 19, 21, 23, 31, 35 AND 44).

LINDSEY RUBIN, EXAMINING ATTORNEY

**CLASS 13—FIREARMS**

SN 85-051,372. THE MARLIN FIREARMS COMPAY, NORTH HAVEN, CT. FILED 6-1-2010.

**SOFT TECH**

THE MARK CONSISTS OF STANDARD CHARACTERS WITHOUT CLAIM TO ANY PARTICULAR FONT, STYLE, SIZE, OR COLOR.

NO CLAIM IS MADE TO THE EXCLUSIVE RIGHT TO USE "SOFT", APART FROM THE MARK AS SHOWN.

FOR RECOIL PADS FOR FIREARMS SOLD AS AN INTEGRAL COMPONENT OF FIREARMS (U.S. CLS. 2 AND 9).

FIRST USE 9-0-2007; IN COMMERCE 9-0-2007.  
MICHAEL WEBSTER, EXAMINING ATTORNEY

**CLASS 13—(Continued).**

SN 85-118,449. I.O., INC., MONROE, NC. FILED 8-30-2010.



NO CLAIM IS MADE TO THE EXCLUSIVE RIGHT TO USE "INC.", APART FROM THE MARK AS SHOWN.

THE MARK CONSISTS OF THE LETTERS "I.O. INC." TOGETHER WITH STYLIZED CROSSHAIRS.

FOR FIREARMS AND FIREARMS ACCESSORIES, NAMELY, GRIPS AND SIGHTS (U.S. CLS. 2 AND 9).

FIRST USE 5-29-2007; IN COMMERCE 5-29-2007.  
BARNEY CHARLON, EXAMINING ATTORNEY

---

SN 85-118,618. I.O., INC., MONROE, NC. FILED 8-30-2010.

**INTER ORDNANCE**

THE MARK CONSISTS OF STANDARD CHARACTERS WITHOUT CLAIM TO ANY PARTICULAR FONT, STYLE, SIZE, OR COLOR.

NO CLAIM IS MADE TO THE EXCLUSIVE RIGHT TO USE "ORDNANCE", APART FROM THE MARK AS SHOWN.

FOR FIREARMS AND FIREARMS ACCESSORIES, NAMELY, GRIPS AND SIGHTS (U.S. CLS. 2 AND 9).

FIRST USE 10-1-1995; IN COMMERCE 10-1-1995.  
BARNEY CHARLON, EXAMINING ATTORNEY

---

SN 85-122,010. FIOCCHI OF AMERICA, INC., OZARK, MO. FILED 9-2-2010.

**GREEN AND MEAN**

THE MARK CONSISTS OF STANDARD CHARACTERS WITHOUT CLAIM TO ANY PARTICULAR FONT, STYLE, SIZE, OR COLOR.

NO CLAIM IS MADE TO THE EXCLUSIVE RIGHT TO USE "GREEN", APART FROM THE MARK AS SHOWN.

FOR AMMUNITION (U.S. CLS. 2 AND 9).  
DEZMONA MIZELLE, EXAMINING ATTORNEY

**CLASS 13—(Continued).**

SN 85-178,949. SUREFIRE, LLC, FOUNTAIN VALLEY, CA.  
FILED 11-17-2010.

**FAST-ATTACH**

THE MARK CONSISTS OF STANDARD CHARACTERS WITHOUT CLAIM TO ANY PARTICULAR FONT, STYLE, SIZE, OR COLOR.

OWNER OF U.S. REG. NO. 3,005,193.  
SEC. 2(F).

FOR SILENCERS FOR FIREARMS; FIREARM ADAPTERS FOR USE WITH SILENCERS; SILENCER KITS COMPOSED OF A SILENCER, AN ADAPTER AND SHIMS FOR USE WITH AN ADAPTER (U.S. CLS. 2 AND 9).

FIRST USE 7-2-2003; IN COMMERCE 12-2-2003.  
SANJEEV VOHRA, EXAMINING ATTORNEY

**CLASS 14—(Continued).**

SN 77-693,848. BATTERIES & BANDS, INC., SANDY, UT.  
FILED 3-18-2009.

**CLASS 14—JEWELRY**

SN 77-316,226. SIEMPRE UNIDOS, MILL VALLEY, CA.  
FILED 10-29-2007.

**SIEMPRE SOL**

THE MARK CONSISTS OF STANDARD CHARACTERS WITHOUT CLAIM TO ANY PARTICULAR FONT, STYLE, SIZE, OR COLOR.

THE FOREIGN WORDING IN THE MARK TRANSLATES INTO ENGLISH AS ALWAYS SUN OR FOREVER SUN.

FOR JEWELRY, NAMELY, NECKLACES, EARRINGS, CROSSES, CRUCIFIXES, ROSARIES, PRAYER BEADS, PENDANTS, BRACELETS, ANKLETS, LANYARDS, JEWELLED HANGERS FOR EYEGASSES AND RINGS, EXCLUDING DIAMONDS (U.S. CLS. 2, 27, 28 AND 50).

FIRST USE 10-5-2007; IN COMMERCE 10-5-2007.  
JEFF DEFORD, EXAMINING ATTORNEY

THE MARK CONSISTS OF THE WORDS "LONDON UNDERGROUND" OVER HALF OF A BRITISH UNION JACK.

FOR WATCHES (U.S. CLS. 2, 27, 28 AND 50).  
EMILY CARLSEN, EXAMINING ATTORNEY

SN 77-844,992. ZERONE LIMITED, KOWLOON BAY, HONG KONG, FILED 10-9-2009.



SN 77-693,832. BATTERIES & BANDS, INC., SANDY, UT.  
FILED 3-18-2009.

**LONDON UNDERGROUND**

THE MARK CONSISTS OF STANDARD CHARACTERS WITHOUT CLAIM TO ANY PARTICULAR FONT, STYLE, SIZE, OR COLOR.

FOR WATCHES (U.S. CLS. 2, 27, 28 AND 50).  
EMILY CARLSEN, EXAMINING ATTORNEY

OWNER OF HONG KONG REG. NO. 300766972, DATED 11-24-2006, EXPIRES 11-23-2016.

THE MARK CONSISTS OF THE TERM "ZERONE" IN A STYLIZED FONT, WITH THE LETTER "R" SHOWN BACKWARDS, AND THE LETTER "O" APPEARING WITH A GRAPHIC OF A FLAME EXTENDING FROM IT.

FOR WATCHES, WATCH STRAPS, WATCH PARTS, CLOCKS, CHRONOMETRIC INSTRUMENTS, HOROLOGICAL AND CHRONOMETRIC INSTRUMENTS (U.S. CLS. 2, 27, 28 AND 50).

ALYSSA STEEL, EXAMINING ATTORNEY

**CLASS 14—(Continued).**

SN 77-856,626. GREEN, CAROLEEN, BURBANK, CA. FILED 10-24-2009.



THE MARK CONSISTS OF A SKULL AND CROSSED SWORD DESIGN TO THE LEFT OF THE WORDING "PIRATE BITCH LOOT" WITH THE WORDING "PIRATE BITCH" APPEARING ABOVE THE WORD "LOOT".

FOR COSTUME JEWELRY (U.S. CLS. 2, 27, 28 AND 50).

FIRST USE 8-20-2009; IN COMMERCE 9-16-2009.  
JAMES LOVELACE, EXAMINING ATTORNEY

**CLASS 14—(Continued).**

SN 77-960,311. ROCHELLE FISHER, FLUSHING, NY. FILED 3-16-2010.

OOLERY BY ROCHELLE

THE MARK CONSISTS OF STANDARD CHARACTERS WITHOUT CLAIM TO ANY PARTICULAR FONT, STYLE, SIZE, OR COLOR.

THE NAME(S), PORTRAIT(S), AND/OR SIGNATURE(S) SHOWN IN THE MARK IDENTIFIES "ROCHELLE FISHER", WHOSE CONSENT(S) TO REGISTER IS MADE OF RECORD.

FOR JEWELRY FOR BABIES, CHILDREN AND ADULTS, NAMELY, RINGS, CHAINS, PENDANTS, BRACELETS, ANKLETS, EARRINGS, WATCHES, BROACHES, BANGLES, AND CHARMS (U.S. CLS. 2, 27, 28 AND 50).

JOHN KELLY, EXAMINING ATTORNEY

SN 77-908,828. MUNOZ, MARIA DEL CARMEN, HOUSTON, TX. FILED 1-11-2010.

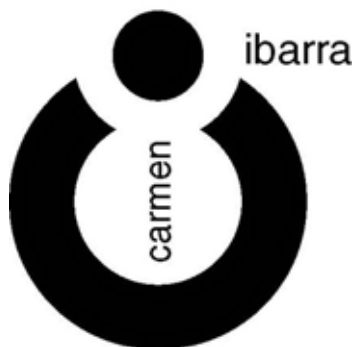

SN 79-084,034. MONTRES ICARUS S.A., SWITZERLAND, FILED 5-17-2010.

ICARUS

THE NAME "CARMEN IBARRA" IDENTIFIES THE NICKNAME OF MARIA DEL CARMEN MUNOZ, A LIVING INDIVIDUAL WHOSE CONSENT IS OF RECORD.

THE MARK CONSISTS OF AN INCOMPLETE CIRCLE SURROUNDING THE WORD "CARMEN" WITH A FULL CIRCLE AT THE TOP; THE WORD "IBARRA" APPEARS TO THE RIGHT OF THE FULL CIRCLE; THE WORDS "CARMEN" AND "IBARRA" ARE AT A PERPENDICULAR ANGLE.

FOR JEWELRY (U.S. CLS. 2, 27, 28 AND 50).  
FIRST USE 3-1-1999; IN COMMERCE 7-15-2002.  
COLLEEN DOMBROW, EXAMINING ATTORNEY

THE MARK CONSISTS OF STANDARD CHARACTERS WITHOUT CLAIM TO ANY PARTICULAR FONT, STYLE, SIZE, OR COLOR.

OWNER OF INTERNATIONAL REGISTRATION 0921655 DATED 2-19-2007. EXPIRES 2-19-2017.

FOR HOROLOGICAL AND CHRONOMETRIC INSTRUMENTS; WRIST-WATCHES; JEWELRY IN THE FORM OF NON-MONETARY COINS MADE OF PRECIOUS METALS (U.S. CLS. 2, 27, 28 AND 50).

WILLIAM VERHOSEK, EXAMINING ATTORNEY

**CLASS 14—(Continued).**

SN 85-006,911. SUMMIT ENTERTAINMENT, LLC, SANTA MONICA, CA. FILED 4-6-2010.



THE MARK CONSISTS OF A CIRCULAR TRIBAL TATTOO DESIGN DEPICTING TWO WOLVES FACING ONE ANOTHER IN A HOWLING POSITION, SET AMONGST NUMEROUS INTERWOVEN LINES AND SHAPES AND ALL WITHIN THE CIRCLE.

FOR (BASED ON USE IN COMMERCE) DOG TAGS FOR WEAR BY HUMANS FOR DECORATIVE PURPOSES; JEWELRY; JEWELRY BOXES; JEWELRY SETS COMPRISED PRIMARILY OF JEWELRY; RUBBER BRACELETS; SILVER WRIST CUFF BRACELETS (BASED ON INTENT TO USE) CLOCKS; JEWELRY BOXES OF METAL; LAPEL PINS; MEDALS; SUN DIALS; WATCH BANDS; WATCH BRACELETS; WATCHES; WRIST CUFFS OF BRASS OR RESIN (U.S. CLS. 2, 27, 28 AND 50).

FIRST USE 11-0-2009; IN COMMERCE 11-0-2009.  
TRACY FLETCHER, EXAMINING ATTORNEY

SN 85-008,882. ELCHUCK, STEPHANIE, OCEANSIDE, CA. FILED 4-7-2010.

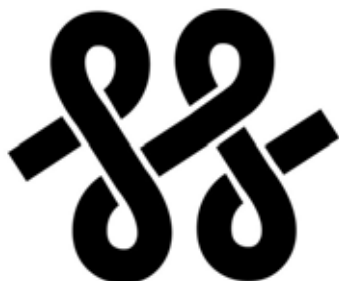

THE MARK CONSISTS OF TWO CURSIVE "S"'S, SIDE BY SIDE AND ATTACHED.

FOR STONE JEWELRY (U.S. CLS. 2, 27, 28 AND 50).  
FIRST USE 7-1-2009; IN COMMERCE 7-1-2009.  
DEBRA LEE, EXAMINING ATTORNEY

**CLASS 14—(Continued).**

SN 85-034,465. DEELS INC, BEVERLY HILLS, CA. FILED 5-10-2010.

**Cat Deeley Modern Vintage**

THE MARK CONSISTS OF STANDARD CHARACTERS WITHOUT CLAIM TO ANY PARTICULAR FONT, STYLE, SIZE, OR COLOR.

NO CLAIM IS MADE TO THE EXCLUSIVE RIGHT TO USE "MODERN VINTAGE", APART FROM THE MARK AS SHOWN.

THE NAME(S), PORTRAIT(S), AND/OR SIGNATURE(S) SHOWN IN THE MARK IDENTIFIES "CAT DEELEY", WHOSE CONSENT(S) TO REGISTER IS MADE OF RECORD.

FOR JEWELRY (U.S. CLS. 2, 27, 28 AND 50).  
FIRST USE 6-18-2010; IN COMMERCE 6-18-2010.  
TIMOTHY FINNEGAN, EXAMINING ATTORNEY

SN 85-047,888. NELSON JEWELLERY ARTS CO., LTD., HUNG HOM, KOWLOON, HONG KONG, FILED 5-26-2010.

**BRIDAL MAGIC**

THE MARK CONSISTS OF STANDARD CHARACTERS WITHOUT CLAIM TO ANY PARTICULAR FONT, STYLE, SIZE, OR COLOR.

OWNER OF HONG KONG REG. NO. 300760392, DATED 11-14-2006, EXPIRES 11-14-2016.

NO CLAIM IS MADE TO THE EXCLUSIVE RIGHT TO USE "BRIDAL", APART FROM THE MARK AS SHOWN.

FOR JEWELRY; BRACELETS; JEWELRY CHAINS; JEWELRY WATCHES; RINGS BEING JEWELRY; ORNAMENTS OF PRECIOUS METAL; NECKLACES; EARRINGS; JEWEL PENDANTS; PRECIOUS STONES (U.S. CLS. 2, 27, 28 AND 50).

STEVEN R. FINE, EXAMINING ATTORNEY

SN 85-083,069. S&I CREATIONS, LLC, PHILADELPHIA, PA. FILED 7-13-2010.

**SOPHIA BY DESIGN**

THE MARK CONSISTS OF STANDARD CHARACTERS WITHOUT CLAIM TO ANY PARTICULAR FONT, STYLE, SIZE, OR COLOR.

NO CLAIM IS MADE TO THE EXCLUSIVE RIGHT TO USE "DESIGN", APART FROM THE MARK AS SHOWN.

FOR JEWELRY (U.S. CLS. 2, 27, 28 AND 50).

FIRST USE 0-0-2005; IN COMMERCE 0-0-2005.

JACQUELINE A. LAVINE, EXAMINING ATTORNEY

**CLASS 14—(Continued).**

SN 85-085,227. CLOGAU GOLD OF WALES LTD., RHYL, WALES, FILED 7-15-2010.

**INNER CHARM**

THE MARK CONSISTS OF STANDARD CHARACTERS WITHOUT CLAIM TO ANY PARTICULAR FONT, STYLE, SIZE, OR COLOR.

OWNER OF ERPN CMNTY TM OFC REG. NO. 008683609, DATED 5-21-2010, EXPIRES 11-12-2019.

FOR JEWELLERY, WATCHES, CLOCKS, TIME PIECES, KEY RINGS MADE OF PRECIOUS METAL, KEY FOBS MADE OF PRECIOUS METAL, JEWELLERY BOXES, TIE PINS AND CUFFLINKS; JEWELLERY MADE OF GOLD, OR MADE IN WHOLE OR SUBSTANTIAL PART OF GOLD; WATCHES AND CLOCKS MADE OF GOLD, OR MADE IN WHOLE OR SUBSTANTIAL PART OF GOLD; TIME PIECES MADE OF GOLD, OR MADE IN WHOLE OR SUBSTANTIAL PART OF GOLD; JEWELLERY BOXES MADE OF GOLD, OR MADE IN WHOLE OR SUBSTANTIAL PART OF GOLD (U.S. CLS. 2, 27, 28 AND 50).

RUSS HERMAN, EXAMINING ATTORNEY

SN 85-092,576. ALTRUETTE INC., BOULDER, CO. FILED 7-26-2010.

**ALTRUETTE**

THE MARK CONSISTS OF STANDARD CHARACTERS WITHOUT CLAIM TO ANY PARTICULAR FONT, STYLE, SIZE, OR COLOR.

THE WORDING "ALTRUETTE" HAS NO MEANING IN A FOREIGN LANGUAGE.

FOR JEWELRY; PERSONAL JEWELRY CHARMS; CHARM-BRACELETS; CUFFLINKS; KEY CHAINS AS JEWELRY (U.S. CLS. 2, 27, 28 AND 50).

FIRST USE 10-4-2010; IN COMMERCE 10-25-2010.

MARIA-VICTORIA SUAREZ, EXAMINING ATTORNEY

SN 85-093,785. S&I CREATIONS, LLC, PHILADELPHIA, PA. FILED 7-27-2010.



NO CLAIM IS MADE TO THE EXCLUSIVE RIGHT TO USE "COUTURE", APART FROM THE MARK AS SHOWN.

THE MARK CONSISTS OF THE STYLIZED WORDING "SOPHIA COUTURE" WITH A CROWN ON TOP OF THE LETTER "A" OF THE WORD "SOPHIA".

FOR JEWELRY (U.S. CLS. 2, 27, 28 AND 50).

JACQUELINE A. LAVINE, EXAMINING ATTORNEY

**CLASS 14—(Continued).**

SN 85-099,796. THIEN PO LTD., BANGKOK, THAILAND, FILED 8-4-2010.



THE MARK CONSISTS OF A STYLIZED DESIGN MADE UP OF A SERIES OF CURVILINEAR LINES; SAID CURVILINEAR LINES FORM AN OVAL WITH TWO SHORT LINES ON THE INSIDE OF THE OVAL WHICH EXTEND INWARDS; SAID OVAL IS ON TOP OF A BASE MEMBER WITH TWO HALF OVALS EXTENDING UPWARDS FROM THE TOP OF SAID OVAL ON THE LEFT AND RIGHT SIDES; AND AN ARCIFORM LINE EXTENDS FROM THE TOP OF THE LEFT SIDE HALF OVAL.

FOR JEWELRY (U.S. CLS. 2, 27, 28 AND 50).

FIRST USE 8-2-2010; IN COMMERCE 8-2-2010.

DOMINIC J. FERRAIUOLO, EXAMINING ATTORNEY

SN 85-102,564. CHAMBERS, JO BEAN, AKA CHAMBERS, JO ANN, MIAMI, FL. FILED 8-7-2010.

**JOBEAN GLASS**

THE MARK CONSISTS OF STANDARD CHARACTERS WITHOUT CLAIM TO ANY PARTICULAR FONT, STYLE, SIZE, OR COLOR.

NO CLAIM IS MADE TO THE EXCLUSIVE RIGHT TO USE "GLASS", APART FROM THE MARK AS SHOWN.

FOR BEADS FOR USE IN THE MANUFACTURE OF JEWELRY (U.S. CLS. 2, 27, 28 AND 50).

FIRST USE 1-10-1993; IN COMMERCE 1-10-1993.

BRENDAN REGAN, EXAMINING ATTORNEY

SN 85-116,289. WORLD TRADE GOLDEN NUGGET LTD., DBA WORLD TRADE JEWELERS, NEW YORK, NY. FILED 8-26-2010.

**SILVER ON THE ROCKS**

THE MARK CONSISTS OF STANDARD CHARACTERS WITHOUT CLAIM TO ANY PARTICULAR FONT, STYLE, SIZE, OR COLOR.

NO CLAIM IS MADE TO THE EXCLUSIVE RIGHT TO USE "SILVER", APART FROM THE MARK AS SHOWN.

FOR JEWELRY MADE IN WHOLE OR SIGNIFICANT PART OF SILVER (U.S. CLS. 2, 27, 28 AND 50).

KIM SAITO, EXAMINING ATTORNEY

**CLASS 14—(Continued).**

SN 85-135,008. ENERGY ARMOR INC., JACKSONVILLE, FL.  
FILED 9-21-2010.

**ENERGY / ARMOR**

THE MARK CONSISTS OF STANDARD CHARACTERS WITHOUT CLAIM TO ANY PARTICULAR FONT, STYLE, SIZE, OR COLOR.

NO CLAIM IS MADE TO THE EXCLUSIVE RIGHT TO USE "ENERGY", APART FROM THE MARK AS SHOWN.

FOR BRACELETS; RUBBER OR SILICON WRISTBANDS IN THE NATURE OF A BRACELET (U.S. CLS. 2, 27, 28 AND 50).

FIRST USE 9-1-2010; IN COMMERCE 9-1-2010.  
NAKIA HENRY, EXAMINING ATTORNEY

SN 85-137,342. NANETTE RUBEN LLC, DBA NANETTE RUBEN, FRISCO, TX. FILED 9-24-2010.



NANETTE RUBEN

THE NAME SHOWN IN THE MARK DOES NOT IDENTIFY A PARTICULAR LIVING INDIVIDUAL.

THE MARK CONSISTS OF "NANETTE RUBEN" AND THE STYLIZED LETTERS "NR".

FOR JEWELRY (U.S. CLS. 2, 27, 28 AND 50).  
EDWARD NELSON, EXAMINING ATTORNEY

SN 85-152,182. CHOI, HEE SOON, INDEPENDENCE, KY.  
FILED 10-13-2010.

**SKY DREAMS**

THE MARK CONSISTS OF STANDARD CHARACTERS WITHOUT CLAIM TO ANY PARTICULAR FONT, STYLE, SIZE, OR COLOR.

FOR JEWELRY, NAMELY, EARRINGS, NECKLACES, BRACELETS, RINGS, ANKLETS (U.S. CLS. 2, 27, 28 AND 50).

FIRST USE 9-1-2006; IN COMMERCE 9-1-2006.  
ROBIN CHOSID, EXAMINING ATTORNEY

**CLASS 14—(Continued).**

SN 85-152,533. QUALITY GOLD, INC., FAIRFIELD, OH.  
FILED 10-14-2010.

**MADDI K**

THE MARK CONSISTS OF STANDARD CHARACTERS WITHOUT CLAIM TO ANY PARTICULAR FONT, STYLE, SIZE, OR COLOR.

THE NAME "MADDI K" DOES NOT IDENTIFY A LIVING INDIVIDUAL.

FOR JEWELRY (U.S. CLS. 2, 27, 28 AND 50).  
CHARLES L. JENKINS, EXAMINING ATTORNEY

SN 85-153,015. REILLY, K:IMBERLY A, SARASOTA, FL.  
FILED 10-14-2010.

**Smilingual**

THE MARK CONSISTS OF STANDARD CHARACTERS WITHOUT CLAIM TO ANY PARTICULAR FONT, STYLE, SIZE, OR COLOR.

FOR BODY JEWELRY; BRACELETS; CHARMS; COSTUME JEWELRY; JEWELRY; JEWELRY AND IMITATION JEWELRY; JEWELRY CASES; JEWELRY, NAMELY, ANKLETS; RINGS; RINGS BEING JEWELRY; WATCHES AND JEWELRY; WOMEN'S JEWELRY (U.S. CLS. 2, 27, 28 AND 50).

GEORGE LORENZO, EXAMINING ATTORNEY

SN 85-155,328. JMM LEE PROPERTIES, LLC, BURBANK, CA. FILED 10-18-2010.

**Frogskins**

THE MARK CONSISTS OF STANDARD CHARACTERS WITHOUT CLAIM TO ANY PARTICULAR FONT, STYLE, SIZE, OR COLOR.

OWNER OF U.S. REG. NOS. 3,858,050 AND 3,902,011.  
FOR WATCH BANDS AND STRAPS; WRIST WATCHES (U.S. CLS. 2, 27, 28 AND 50).

GIANCARLO CASTRO, EXAMINING ATTORNEY



**CLASS 14—(Continued).**

SN 85-155,354. KAREN PAGE, BEVERLY HILLS, CA. FILED 10-18-2010.



THE MARK CONSISTS OF TWO SWANS FACING EACH OTHER, WITH A HEART ENCLOSED BETWEEN THEM AND THE WORDING "GRACED HEART" IN STYLIZED FONT BELOW THE DESIGN.

FOR JEWELRY (U.S. CLS. 2, 27, 28 AND 50).  
ELLEN BURNS, EXAMINING ATTORNEY

**CLASS 14—(Continued).**

SN 85-157,765. ARZU, INC., CHICAGO, IL. FILED 10-21-2010.



NO CLAIM IS MADE TO THE EXCLUSIVE RIGHT TO USE "CORD", APART FROM THE MARK AS SHOWN.

THE MARK CONSISTS OF THE WORDS "PEACE CORD" WITH A FANCIFUL, CIRCULAR GEOMETRICAL DESIGN FORMING THE "O" IN THE WORD "CORD". THIS WORDING IS ENCLOSED IN A RECTANGULAR BOX WITH A THIN LINE JUST INSIDE AND ALONG THE BORDER OF THE BOX.

FOR WOVEN BRACELET MADE OF MILITARY GRADE PARACHUTE CORD, LEATHER OR OTHER MATERIAL AND VARIOUS BUTTONS (U.S. CLS. 2, 27, 28 AND 50).

NANCY CLARKE, EXAMINING ATTORNEY

SN 85-159,307. MANCINI, CHERYL, PARKLAND, FL. AND RICHARD MANCINI, PARKLAND, FL. AND DAVID MANCINI, JR., FORT LAUDERDALE, FL. AND ADAM HELLER, PARKLAND, FL. FILED 10-22-2010.

# TRUTH IS

THE MARK CONSISTS OF STANDARD CHARACTERS WITHOUT CLAIM TO ANY PARTICULAR FONT, STYLE, SIZE, OR COLOR.

FOR RUBBER OR SILICON WRISTBANDS IN THE NATURE OF A BRACELET (U.S. CLS. 2, 27, 28 AND 50).  
PATRICIA EVANKO, EXAMINING ATTORNEY

SN 85-155,494. ANDERSON, MARIE ARMS, NASHVILLE, TN. FILED 10-18-2010.



THE MARK CONSISTS OF THE WORDING "PEACE EASY" ARCHED ABOVE AND "LIKE A RIVER" ARCHED BELOW AN OVAL, WITH THE WORD "MARIE" WRITTEN IN STYLIZED SCRIPT INSIDE THE OVAL.

FOR JEWELRY (U.S. CLS. 2, 27, 28 AND 50).  
ELISSA GARBER KON, EXAMINING ATTORNEY

SN 85-159,323. MANCINI, CHERYL, PARKLAND, FL. AND RICHARD MANCINI, PARKLAND, FL. AND DAVID MANCINI, JR., FORT LAUDERDALE, FL. AND ADAM HELLER, PARKLAND, FL. FILED 10-22-2010.

# TRU BANDS

THE MARK CONSISTS OF STANDARD CHARACTERS WITHOUT CLAIM TO ANY PARTICULAR FONT, STYLE, SIZE, OR COLOR.

NO CLAIM IS MADE TO THE EXCLUSIVE RIGHT TO USE "BANDS", APART FROM THE MARK AS SHOWN.

FOR RUBBER OR SILICON WRISTBANDS IN THE NATURE OF A BRACELET (U.S. CLS. 2, 27, 28 AND 50).  
PATRICIA EVANKO, EXAMINING ATTORNEY

**CLASS 14—(Continued).**

SN 85-159,864. JOHNSON, NICCOLE, LAGUNA HILLS, CA. FILED 10-24-2010.

little petite designs

THE MARK CONSISTS OF STANDARD CHARACTERS WITHOUT CLAIM TO ANY PARTICULAR FONT, STYLE, SIZE, OR COLOR.

NO CLAIM IS MADE TO THE EXCLUSIVE RIGHT TO USE "DESIGNS", APART FROM THE MARK AS SHOWN.

FOR JEWELRY; WOMEN'S JEWELRY (U.S. CLS. 2, 27, 28 AND 50).

DORITT L. CARROLL, EXAMINING ATTORNEY

SN 85-162,973. PETERS, DAWN, SAND CITY, CA. FILED 10-27-2010.

Lucky Snaps

THE MARK CONSISTS OF STANDARD CHARACTERS WITHOUT CLAIM TO ANY PARTICULAR FONT, STYLE, SIZE, OR COLOR.

NO CLAIM IS MADE TO THE EXCLUSIVE RIGHT TO USE "SNAPS", APART FROM THE MARK AS SHOWN.

FOR FASHION ACCESSORIES, NAMELY, BRACELET CHARMS AND BRACELETS (U.S. CLS. 2, 27, 28 AND 50). FIRST USE 4-1-2008; IN COMMERCE 4-1-2008.

SHAUNIA CARLYLE, EXAMINING ATTORNEY

SN 85-172,447. MINE O'MINE, INC., WOODLAND HILLS, CA. FILED 11-9-2010.

DUNKMAN

THE MARK CONSISTS OF STANDARD CHARACTERS WITHOUT CLAIM TO ANY PARTICULAR FONT, STYLE, SIZE, OR COLOR.

OWNER OF U.S. REG. NO. 2,919,666.

FOR CLOCKS; JEWELRY; WATCHES (U.S. CLS. 2, 27, 28 AND 50).

KRISTINA MORRIS, EXAMINING ATTORNEY

**CLASS 14—(Continued).**

SN 85-175,084. A BAND APART IMPORTS, LLC, TOLEDO, OH. FILED 11-11-2010.

WILLYBANDZ

THE MARK CONSISTS OF STANDARD CHARACTERS WITHOUT CLAIM TO ANY PARTICULAR FONT, STYLE, SIZE, OR COLOR.

FOR RUBBER OR SILICON WRISTBANDS IN THE NATURE OF A BRACELET (U.S. CLS. 2, 27, 28 AND 50). FIRST USE 9-8-2010; IN COMMERCE 10-22-2010.

BRIAN NEVILLE, EXAMINING ATTORNEY

SN 85-175,967. EILEEN FISHER, INC., IRVINGTON, NY. FILED 11-12-2010.

e

EILEEN FISHER

OWNER OF U.S. REG. NOS. 2,003,225, 3,634,309 AND OTHERS.

THE NAME(S), PORTRAIT(S), AND/OR SIGNATURE(S) SHOWN IN THE MARK IDENTIFIES EILEEN FISHER, WHOSE CONSENT(S) TO REGISTER IS MADE OF RECORD.

THE MARK CONSISTS OF THE LETTER "E" ABOVE THE WORDS "EILEEN FISHER".

FOR JEWELRY (U.S. CLS. 2, 27, 28 AND 50).

FIRST USE 10-29-2010; IN COMMERCE 10-29-2010.

SAMUEL E. SHARPER JR., EXAMINING ATTORNEY

SN 85-176,202. ROSALIND FELDMAN TYMAN, NORTH-FIELD, NJ. FILED 11-13-2010.

Shut It Down.

THE MARK CONSISTS OF STANDARD CHARACTERS WITHOUT CLAIM TO ANY PARTICULAR FONT, STYLE, SIZE, OR COLOR.

FOR BRACELETS; COSTUME JEWELRY; JEWELRY; JEWELRY AND IMITATION JEWELRY; NECKLACES (U.S. CLS. 2, 27, 28 AND 50).

JAMES GRIFFIN, EXAMINING ATTORNEY

**CLASS 14—(Continued).**

SN 85-177,063. GREENE, EVA-MICHELLE GRACE, ASHEVILLE, NC. AND GREENE, MICHAEL E, ASHEVILLE, NC. FILED 11-15-2010.

**CLASS 14—(Continued).**

SN 85-178,043. RICHARD L. HILES, NASHPORT, OH. FILED 11-16-2010.

# Re-Dazzle

THE MARK CONSISTS OF STANDARD CHARACTERS WITHOUT CLAIM TO ANY PARTICULAR FONT, STYLE, SIZE, OR COLOR.

FOR BRACELETS; BROACHES; BROOCHES; CHARMS; DIAMOND JEWELRY; GEMSTONE JEWELRY; JEWELRY; JEWELRY CHAINS; LAPEL PINS; RINGS; WOMEN'S JEWELRY (U.S. CLS. 2, 27, 28 AND 50).

VERNA BETH RIRIE, EXAMINING ATTORNEY



SN 85-178,005. RICHLINE GROUP, INC., MOUNT VERNON, NY. FILED 11-16-2010.

# AMERICANA

THE MARK CONSISTS OF STANDARD CHARACTERS WITHOUT CLAIM TO ANY PARTICULAR FONT, STYLE, SIZE, OR COLOR.

FOR JEWELRY (U.S. CLS. 2, 27, 28 AND 50).  
FIRST USE 3-31-2010; IN COMMERCE 3-31-2010.  
PAUL E. FAHRENKOPF, EXAMINING ATTORNEY



SN 85-178,033. RICHLINE GROUP, INC., MOUNT VERNON, NY. FILED 11-16-2010.

# BEADABLES

THE MARK CONSISTS OF STANDARD CHARACTERS WITHOUT CLAIM TO ANY PARTICULAR FONT, STYLE, SIZE, OR COLOR.

FOR JEWELRY (U.S. CLS. 2, 27, 28 AND 50).  
PAUL E. FAHRENKOPF, EXAMINING ATTORNEY

# CLIPSTER

THE MARK CONSISTS OF STANDARD CHARACTERS WITHOUT CLAIM TO ANY PARTICULAR FONT, STYLE, SIZE, OR COLOR.

FOR WATCHES (U.S. CLS. 2, 27, 28 AND 50).  
ERIN FALK, EXAMINING ATTORNEY



SN 85-179,185. BULLTORO WATCH COMPANY LLC, WOODBRIDGE, CT. FILED 11-17-2010.



THE MARK CONSISTS OF A SHIELD WITH THE LETTER "B" SUPERIMPOSED ON THE LETTER "T".  
FOR WATCHES (U.S. CLS. 2, 27, 28 AND 50).  
FRED CARL, EXAMINING ATTORNEY

**CLASS 14—(Continued).**

SN 85-179,993. CHICK BOSS LLC, EMERYVILLE, CA. FILED 11-18-2010.



THE MARK CONSISTS OF A STYLIZED IMAGE OF A CHICK COMPRISED OF THE UPPERCASE LETTERS "C" AND "B" WITH A BEAK ON THE CURVE OF THE "C", TWO LEGS WITH FEET AT THE BOTTOM OF THE "C", AND THE "B" STYLIZED TO SUGGEST TAIL FEATHERS.  
FOR JEWELRY; JEWELRY BOXES (U.S. CLS. 2, 27, 28 AND 50).  
COLLEEN DOMBROW, EXAMINING ATTORNEY

SN 85-180,319. ELLIS, KORENA I, LOS ANGELES, CA. FILED 11-18-2010.

**XANICA**

THE MARK CONSISTS OF STANDARD CHARACTERS WITHOUT CLAIM TO ANY PARTICULAR FONT, STYLE, SIZE, OR COLOR.  
FOR JEWELRY (U.S. CLS. 2, 27, 28 AND 50).  
FIRST USE 4-24-2010; IN COMMERCE 4-24-2010.  
JIM RINGLE, EXAMINING ATTORNEY

SN 85-180,397. MLA MULTIBRAND HOLDINGS, INC., VERNON, CA. FILED 11-18-2010.

**TWELVE TWO**

THE MARK CONSISTS OF STANDARD CHARACTERS WITHOUT CLAIM TO ANY PARTICULAR FONT, STYLE, SIZE, OR COLOR.  
FOR JEWELRY AND WATCHES (U.S. CLS. 2, 27, 28 AND 50).  
LAURA KOVALSKY, EXAMINING ATTORNEY

**CLASS 14—(Continued).**

SN 85-180,511. MLA MULTIBRAND HOLDINGS, INC., VERNON, CA. FILED 11-18-2010.

**12-2**

THE MARK CONSISTS OF STANDARD CHARACTERS WITHOUT CLAIM TO ANY PARTICULAR FONT, STYLE, SIZE, OR COLOR.  
FOR JEWELRY AND WATCHES (U.S. CLS. 2, 27, 28 AND 50).  
LAURA KOVALSKY, EXAMINING ATTORNEY

SN 85-181,541. THE HUNDREDS IS HUGE, INC., LOS ANGELES, CA. FILED 11-19-2010.



OWNER OF U.S. REG. NO. 3,390,623.  
THE COLOR(S) BLACK, WHITE, YELLOW AND RED IS/ ARE CLAIMED AS A FEATURE OF THE MARK.  
THE MARK CONSISTS OF CARTOON OF A BOMB WITH A HUMAN FACE, ABOUT TO EXPLODE. THE SPARKS OR FLAMES COMING OUT OF THE TOP OF THE BOMB ARE YELLOW AND RED AND THE FACIAL FEATURES ARE BLACK AND WHITE.  
FOR WATCHES (U.S. CLS. 2, 27, 28 AND 50).  
TEJBIR SINGH, EXAMINING ATTORNEY

SN 85-182,483. THE HUNDREDS IS HUGE, INC., LOS ANGELES, CA. FILED 11-22-2010.

**THE HUNDREDS**

OWNER OF U.S. REG. NO. 3,322,159.  
THE MARK CONSISTS OF STYLIZED WORDS "THE HUNDREDS" WITH A CARTOON OF A BOMB ABOUT TO EXPLODE AND SPARKS OR FLAMES ARE COMING OUT OF THE TOP OF THE BOMB.  
FOR WATCHES (U.S. CLS. 2, 27, 28 AND 50).  
TEJBIR SINGH, EXAMINING ATTORNEY

**CLASS 14—(Continued).**

SN 85-184,887. ALBERT GAD LTD., NEW YORK, NY. FILED 11-24-2010.

**CROWN OF LIGHT BLUE**

THE MARK CONSISTS OF STANDARD CHARACTERS WITHOUT CLAIM TO ANY PARTICULAR FONT, STYLE, SIZE, OR COLOR.

OWNER OF U.S. REG. NOS. 2,748,904, 3,840,881 AND OTHERS.

NO CLAIM IS MADE TO THE EXCLUSIVE RIGHT TO USE "BLUE", APART FROM THE MARK AS SHOWN.

FOR CUT DIAMONDS; DIAMOND JEWELRY; DIAMONDS; GEMSTONE JEWELRY; JEWELRY (U.S. CLS. 2, 27, 28 AND 50).

FIRST USE 4-1-2010; IN COMMERCE 4-1-2010.  
ALLISON SCHRODY, EXAMINING ATTORNEY

SN 85-185,015. ALBERT GAD LTD., NEW YORK, NY. FILED 11-24-2010.

**FLEUR DE CROWN**

THE MARK CONSISTS OF STANDARD CHARACTERS WITHOUT CLAIM TO ANY PARTICULAR FONT, STYLE, SIZE, OR COLOR.

OWNER OF U.S. REG. NOS. 2,748,904, 3,840,881 AND OTHERS.

THE ENGLISH TRANSLATION OF "FLEUR DE" IN THE MARK IS "FLOWER OF".

FOR CUT DIAMONDS; DIAMOND JEWELRY; DIAMONDS; GEMSTONE JEWELRY; JEWELRY (U.S. CLS. 2, 27, 28 AND 50).

FIRST USE 4-1-2010; IN COMMERCE 4-1-2010.  
ALLISON SCHRODY, EXAMINING ATTORNEY

SN 85-187,558. HARVEY, JUANITA, DECATUR, IL. FILED 11-30-2010.

**NEFA (no excuse for abuse)**

THE MARK CONSISTS OF STANDARD CHARACTERS WITHOUT CLAIM TO ANY PARTICULAR FONT, STYLE, SIZE, OR COLOR.

FOR RUBBER OR SILICON WRISTBANDS IN THE NATURE OF A BRACELET (U.S. CLS. 2, 27, 28 AND 50).

REBECCA SMITH, EXAMINING ATTORNEY

**CLASS 14—(Continued).**

SN 85-195,330. SELFWORX.COM LLC, DBA J:B SAVANT, SCARBOROUGH, ME. FILED 12-10-2010.

**J:B SAVANT**

THE MARK CONSISTS OF STANDARD CHARACTERS WITHOUT CLAIM TO ANY PARTICULAR FONT, STYLE, SIZE, OR COLOR.

FOR TIMEPIECES; WATCHES; WRIST WATCHES (U.S. CLS. 2, 27, 28 AND 50).

PATRICIA EVANKO, EXAMINING ATTORNEY

SN 85-219,223. PANAMA JACK INTERNATIONAL, INC., ORLANDO, FL. FILED 1-17-2011.

**PJ OUTFITTER**

THE MARK CONSISTS OF STANDARD CHARACTERS WITHOUT CLAIM TO ANY PARTICULAR FONT, STYLE, SIZE, OR COLOR.

FOR JEWELRY, JEWELRY RINGS, ANKLE BRACELETS, BRACELETS, NECKLACES, EARRINGS, PENDANTS AND ORNAMENTAL PINS; BODY PIERCING RINGS; CHARMS, CLOCKS; JEWELRY CHAINS; WATCHES (U.S. CLS. 2, 27, 28 AND 50).

AMY KERTGATE, EXAMINING ATTORNEY

SN 85-975,080. PHI DELTA THETA FRATERNITY, OXFORD, OH. FILED 8-26-2010.



OWNER OF U.S. REG. NOS. 224,978, 2,688,127 AND 2,837,693.

THE MARK CONSISTS OF A THREE-DIMENSIONAL CONFIGURATION OF THE GOODS HAVING A SHIELD WITH A BORDER INCLUDING A SERIES OF CIRCLES;

**CLASS 14—(Continued).**

WITHIN THE UPPER PORTION OF THE SHIELD IS A SUN OR EYE WITH OUTWARDLY EXTENDING RAYS AND WITHIN THE LOWER PORTION OF THE SHIELD IS A SCROLL BEARING THE GREEK LETTERS PHI, DELTA AND THETA; EXTENDING FROM THE BACK OF THE SHIELD IS A SWORD WITH THE TIP BELOW THE SHIELD AND THE HAFT ABOVE THE SHIELD; A CHAIN CONNECTS THE HAFT OF THE SWORD TO THE SIDE OF THE SHIELD; THE PORTION OF THE DRAWING IN DASHED LINES FORMS NO PART OF THE MARK.

SEC. 2(F).

FOR FRATERNITY BADGES MADE PRIMARILY OF PRECIOUS METAL AND JEWELS (U.S. CLS. 2, 27, 28 AND 50).

FIRST USE 0-0-1874; IN COMMERCE 0-0-1874.

DAVID H. STINE, EXAMINING ATTORNEY

**CLASS 15—MUSICAL INSTRUMENTS**

SN 79-090,656. LIAOCHENG SUNSMILE MUSICAL INSTRUMENT INC., CHINA, FILED 11-12-2010.



OWNER OF INTERNATIONAL REGISTRATION 1060219 DATED 11-12-2010, EXPIRES 11-12-2020.

FOR REEDS; CLARIONETS; MUSICAL INSTRUMENTS; STRINGED MUSICAL INSTRUMENTS; HORNS BEING MUSICAL INSTRUMENTS; GUITARS; ELECTRONIC MUSICAL INSTRUMENTS; MANDOLINS; VIOLINS; STRINGS FOR MUSICAL INSTRUMENTS (U.S. CLS. 2, 21 AND 36).

KELLY TRUSILO, EXAMINING ATTORNEY

SN 85-072,713. KURATH, WILL, FLUMS, SWITZERLAND, FILED 6-28-2010.



THE MARK CONSISTS OF THE WORD "WILLSON" IN A STYLIZED FONT.

SEC. 2(F).

FOR BRASSWIND MUSICAL INSTRUMENTS, TRUMPETS, CORNETS, FLUGELHORNS, TRUMPONES, FRENCH HORNS, ALTO HORNS, BARITONES, EUPHONIUMS, HORNS, TUBAS (U.S. CLS. 2, 21 AND 36).

FIRST USE 0-0-1980; IN COMMERCE 0-0-1980.

MICHAEL KEATING, EXAMINING ATTORNEY

**CLASS 15—(Continued).**

SN 85-125,994. MONTELEONE, JOHN, ISLIP, NY. FILED 9-9-2010.



THE MARK CONSISTS OF STANDARD CHARACTERS WITHOUT CLAIM TO ANY PARTICULAR FONT, STYLE, SIZE, OR COLOR.

SEC. 2(F).

FOR STRINGED MUSICAL INSTRUMENTS, NAMELY, GUITARS, MANDOLINS, BANJOS, BASSES, AND VIOLINS; MUSICAL INSTRUMENT STANDS (U.S. CLS. 2, 21 AND 36).

FIRST USE 9-0-1976; IN COMMERCE 9-0-1976.

KATINA MISTER, EXAMINING ATTORNEY

SN 85-156,699. DRUMAGINATION, INC., NEW SMYRNA BEACH, FL. FILED 10-20-2010.



THE MARK CONSISTS OF STANDARD CHARACTERS WITHOUT CLAIM TO ANY PARTICULAR FONT, STYLE, SIZE, OR COLOR.

FOR ELECTRONIC MUSICAL INSTRUMENTS (U.S. CLS. 2, 21 AND 36).

FIRST USE 1-25-2005; IN COMMERCE 4-16-2006.

JAMES LOVELACE, EXAMINING ATTORNEY

SN 85-176,877. LAUL ESTONIA PIANO FACTORY LTD., STONY POINT, NY. FILED 11-15-2010.



THE MARK CONSISTS OF STANDARD CHARACTERS WITHOUT CLAIM TO ANY PARTICULAR FONT, STYLE, SIZE, OR COLOR.

OWNER OF U.S. REG. NO. 3,780,776.

SEC. 2(F).

FOR MUSICAL INSTRUMENTS; PIANOS (U.S. CLS. 2, 21 AND 36).

FIRST USE 0-0-1999; IN COMMERCE 0-0-1999.

HELENE LIWINSKI, EXAMINING ATTORNEY

**CLASS 15—(Continued).**

SN 85-185,950. GIBSON GUITAR CORP., NASHVILLE, TN.  
FILED 11-29-2010.

**GIBSON KALAMAZOO AWARD**

THE MARK CONSISTS OF STANDARD CHARACTERS  
WITHOUT CLAIM TO ANY PARTICULAR FONT, STYLE,  
SIZE, OR COLOR.

OWNER OF U.S. REG. NOS. 2,738,824 AND 3,257,493.  
FOR BASS GUITARS; ELECTRIC BASS GUITARS;  
ELECTRIC GUITARS; GUITARS (U.S. CLS. 2, 21 AND  
36).

ELIZABETH KAJUBI, EXAMINING ATTORNEY

---

**CLASS 16—(Continued).**

SN 77-355,161. PAPERLINX NORTH AMERICA, INC, SANTA  
FE SPRINGS, CA. FILED 12-18-2007.

**GO GREEN WITH ENVI**

THE MARK CONSISTS OF STANDARD CHARACTERS  
WITHOUT CLAIM TO ANY PARTICULAR FONT, STYLE,  
SIZE, OR COLOR.

OWNER OF U.S. REG. NOS. 3,496,272 AND 3,567,943.  
FOR RECYCLED COMMERCIAL PRINTING PAPER  
(U.S. CLS. 2, 5, 22, 23, 29, 37, 38 AND 50).  
BILL DAWE, EXAMINING ATTORNEY

---

**CLASS 16—PAPER GOODS AND PRINTED  
MATTER**

SN 76-702,469. THOMAS NELSON, INC., NASHVILLE, TN.  
FILED 4-13-2010.



NO CLAIM IS MADE TO THE EXCLUSIVE RIGHT TO  
USE "KJV", APART FROM THE MARK AS SHOWN.

THE MARK CONSISTS OF THE STYLIZED WORDING  
"KJV 400" WITH A STYLIZED DEPICTION OF A CROWN  
PLACED ATOP THE "J" IN "KJV".

FOR BIBLES (U.S. CLS. 2, 5, 22, 23, 29, 37, 38 AND 50).  
FRED CARL, EXAMINING ATTORNEY

---

SN 77-836,900. SEALED AIR CORPORATION (US), ELM-  
WOOD PARK, NJ. FILED 9-29-2009.



THE MARK CONSISTS OF STANDARD CHARACTERS  
WITHOUT CLAIM TO ANY PARTICULAR FONT, STYLE,  
SIZE, OR COLOR.

FOR PAPER BAGS FOR PACKING AND MAILING  
ARTICLES (U.S. CLS. 2, 5, 22, 23, 29, 37, 38 AND 50).  
ALEX KEAM, EXAMINING ATTORNEY

---

SN 76-702,578. DAVIS,GAIL, HOUSTON, TX. FILED 4-22-  
2010.



THE MARK CONSISTS OF STANDARD CHARACTERS  
WITHOUT CLAIM TO ANY PARTICULAR FONT, STYLE,  
SIZE, OR COLOR.

NO CLAIM IS MADE TO THE EXCLUSIVE RIGHT TO  
USE "PET", APART FROM THE MARK AS SHOWN.

FOR PET SUPPLIES IN THE NATURE OF PLASTIC  
BAGS, PAPER BAGS, BAGS MADE OF PLASTIC AND  
PAPER, AND PAPER CONTAINERS FOR REMOVAL  
AND DISPOSAL OF PET WASTE AND LITTER PRO-  
DUCTS, NAMELY, SINGLE LAYER BAGS, MULTIPLE  
LAYER BAGS, SCENTED BAGS, AND BAGS HAVING  
FILTERS FOR CONTAINING PET WASTE AND LITTER  
PRODUCTS (U.S. CLS. 2, 5, 22, 23, 29, 37, 38 AND 50).

ANDREA HACK, EXAMINING ATTORNEY

SN 77-856,048. MARCAL MANUFACTURING, LLC, ELM-  
WOOD PARK, NJ. FILED 10-23-2009.



THE MARK CONSISTS OF STANDARD CHARACTERS  
WITHOUT CLAIM TO ANY PARTICULAR FONT, STYLE,  
SIZE, OR COLOR.

FOR PAPER PRODUCTS, NAMELY, PAPER TOWELS,  
BATHROOM TISSUES, FACIAL TISSUES, NAPKINS  
(U.S. CLS. 2, 5, 22, 23, 29, 37, 38 AND 50).

MEGHAN REINHART, EXAMINING ATTORNEY

**CLASS 16—(Continued).**

SN 77-887,677. KANGARO INDUSTRIES (REGD.), LUDHIANA, INDIA, FILED 12-7-2009.

# MILES

THE MARK CONSISTS OF STANDARD CHARACTERS WITHOUT CLAIM TO ANY PARTICULAR FONT, STYLE, SIZE, OR COLOR.

FOR STAPLERS, STAPLES, STAPLE REMOVERS, OFFICE PERFORATORS, PAPER HOLE PUNCHES (U.S. CLS. 2, 5, 22, 23, 29, 37, 38 AND 50).

MARC LEIPZIG, EXAMINING ATTORNEY

**CLASS 16—(Continued).**

SN 77-931,526. W2007 STRATOSPHERE PROPCO, L.P., LAS VEGAS, NV. FILED 2-9-2010.



OWNER OF U.S. REG. NOS. 2,086,400, 2,086,401 AND 3,212,812.

NO CLAIM IS MADE TO THE EXCLUSIVE RIGHT TO USE "LAS VEGAS", APART FROM THE MARK AS SHOWN.

THE MARK CONSISTS OF THE WORDS "SKY JUMP STRATOSPHERE LAS VEGAS" STAGGERED AND VERTICALLY POSITIONED OVER A TARGET.

FOR BOOKMARKS; CALENDARS; CHILDREN'S ACTIVITY BOOKS; COUPONS; GIFT CARDS; GREETING CARDS; PHOTOGRAPHS; PICTURES; POSTCARDS; POSTERS; PRINTED TICKETS; STATIONERY; STICKERS; WRITING INSTRUMENTS (U.S. CLS. 2, 5, 22, 23, 29, 37, 38 AND 50).

PAUL E. FAHRENKOPF, EXAMINING ATTORNEY

SN 77-929,267. NEW LEAF PAPER, SAN FRANCISCO, CA. FILED 2-5-2010.

# Farm Fiber

THE MARK CONSISTS OF STANDARD CHARACTERS WITHOUT CLAIM TO ANY PARTICULAR FONT, STYLE, SIZE, OR COLOR.

NO CLAIM IS MADE TO THE EXCLUSIVE RIGHT TO USE "FIBER", APART FROM THE MARK AS SHOWN.

FOR ENVELOPES; PAPER (U.S. CLS. 2, 5, 22, 23, 29, 37, 38 AND 50).

FIRST USE 2-24-2009; IN COMMERCE 2-24-2009.

MARK T. MULLEN, EXAMINING ATTORNEY

SN 79-083,636. REAL ACADEMIA NACIONAL DE FARMACIA, MADRID, SPAIN, FILED 6-1-2010.

# AEFAR

THE MARK CONSISTS OF STANDARD CHARACTERS WITHOUT CLAIM TO ANY PARTICULAR FONT, STYLE, SIZE, OR COLOR.

PRIORITY DATE OF 5-19-2010 IS CLAIMED.

OWNER OF INTERNATIONAL REGISTRATION 1041619 DATED 6-1-2010, EXPIRES 6-1-2020.

THE WORDING "AEFAR" HAS NO MEANING IN A FOREIGN LANGUAGE.

FOR PRINTED PUBLICATIONS, NAMELY, BOOKS IN THE FIELD OF SCIENTIFIC SUBJECTS; PRINTED REVIEWS, NAMELY, WORK BOOKS IN THE FIELD OF SCIENTIFIC SUBJECTS (U.S. CLS. 2, 5, 22, 23, 29, 37, 38 AND 50).

JAMES STEIN, EXAMINING ATTORNEY



**CLASS 16—(Continued).**

SN 79-084,920. GOLDBUCH GEORG BRÜCKNER GMBH, FED REP GERMANY, FILED 12-10-2009.

goldbuch

OWNER OF INTERNATIONAL REGISTRATION 1044724 DATED 12-10-2009, EXPIRES 12-10-2019.

THE WORDING "GOLDBUCH" TRANSLATES IN ENGLISH TO "GOLD BOOK".

FOR PHOTO ALBUMS; POETRY ALBUMS; DIARIES; RING BINDERS; TELEPHONE DIRECTORIES; ADDRESS BOOKS; ARTICLES MADE OF PAPER AND CARDBOARD, NAMELY, BOXES MADE OF CARDBOARD FOR EXERCISE BOOKS; WRITING DESK SETS; PAPER DESK BASKETS FOR DESK ACCESSORIES, PAPER BAGS FOR USE BY SCHOOL CHILDREN FOR THEIR FIRST DAY OF SCHOOL (U.S. CLS. 2, 5, 22, 23, 29, 37, 38 AND 50).

KAPIL BHANOT, EXAMINING ATTORNEY

SN 85-015,386. ROBERT BENTLEY, INC., CAMBRIDGE, MA. FILED 4-16-2010.

LINNAEAN

THE MARK CONSISTS OF STANDARD CHARACTERS WITHOUT CLAIM TO ANY PARTICULAR FONT, STYLE, SIZE, OR COLOR.

FOR NON-FICTION BOOKS ON A VARIETY OF TOPICS; SERIES OF FICTION BOOKS ON A VARIETY OF TOPICS; PRINTED EDUCATIONAL MATERIALS IN THE FIELDS OF TEACHING METHODOLOGY; HANDBOOKS AND TRAINING MANUALS IN THE FIELD OF TEACHING METHODOLOGY; NOVELS; SERIES OF FICTION WORKS, NAMELY, NOVELS AND FICTION BOOKS; PRINTED MATERIALS, NAMELY, NOVELS AND SERIES OF FICTION BOOKS AND SHORT STORIES ALL RELATED TO MYSTERIES, SCIENCE FICTION, CRIME, AND ROMANCE (U.S. CLS. 2, 5, 22, 23, 29, 37, 38 AND 50).

FIRST USE 4-0-2009; IN COMMERCE 4-0-2009.

KAPIL BHANOT, EXAMINING ATTORNEY

SN 85-015,478. GING, WILLIAM C., AMARILLO, TX. FILED 4-16-2010.

PROBLEM SOLVER ERASER

THE MARK CONSISTS OF STANDARD CHARACTERS WITHOUT CLAIM TO ANY PARTICULAR FONT, STYLE, SIZE, OR COLOR.

NO CLAIM IS MADE TO THE EXCLUSIVE RIGHT TO USE "ERASER", APART FROM THE MARK AS SHOWN.

FOR ERASERS (U.S. CLS. 2, 5, 22, 23, 29, 37, 38 AND 50).

GENE MACIOL, EXAMINING ATTORNEY

**CLASS 16—(Continued).**

SN 85-015,511. PROFESSIONAL RISK MANAGERS' INTERNATIONAL ASSOCIATION, WILMINGTON, DE. FILED 4-16-2010.

ASSOCIATE PRM

THE MARK CONSISTS OF STANDARD CHARACTERS WITHOUT CLAIM TO ANY PARTICULAR FONT, STYLE, SIZE, OR COLOR.

OWNER OF U.S. REG. NOS. 3,762,385, 3,762,386 AND 3,776,899.

FOR EDUCATIONAL PUBLICATIONS, NAMELY, EXAMINATION STUDY GUIDES AND TEST PAPERS IN THE FIELD OF PROFESSIONAL RISK MANAGEMENT; PRINTED INSTRUCTIONAL, TRAINING AND TEACHING MATERIALS IN THE FIELD OF PROFESSIONAL RISK MANAGEMENT; PRINTED EDUCATIONAL MATERIALS FOR COURSES, TUTORIALS, AND LESSONS IN THE FIELD OF PROFESSIONAL RISK MANAGEMENT (U.S. CLS. 2, 5, 22, 23, 29, 37, 38 AND 50).

FIRST USE 7-23-2008; IN COMMERCE 7-23-2008.

MARGARET POWER, EXAMINING ATTORNEY

SN 85-017,792. PAL BRANDS LIMITED, AUCKLAND, NEW ZEALAND, FILED 4-20-2010.



FOR THE PERFECT FINISH

LEGEND

NO CLAIM IS MADE TO THE EXCLUSIVE RIGHT TO USE "SINCE 1961", APART FROM THE MARK AS SHOWN.

THE MARK CONSISTS OF A DESIGN WITH OVERALL RECTANGULAR SHAPE THAT CONTAINS THE WORD "PAL" TO THE LEFT OF A SINGLE FERN LEAF APPEARING IMMEDIATELY ABOVE THE WORDING "SINCE 1961". UNDERNEATH THE RECTANGULAR SHAPE IS THE UNDERLINED WORDING "FOR THE PERFECT FINISH", WITH THE WORD "LEGEND" IN LARGE CAPITAL LETTERS UNDERNEATH.

FOR PAINT BRUSHES, PAINT ROLLERS, PAINT PADDLES, PAINT STIRRERS, PAINT APPLICATORS AND PAINT TRAYS (U.S. CLS. 2, 5, 22, 23, 29, 37, 38 AND 50).

RAUL CORDOVA, EXAMINING ATTORNEY

**CLASS 16—(Continued).**

SN 85-023,015. COOLEY, ANN, LEXINGTON, KY. FILED 4-26-2010.



THE MARK CONSISTS OF A HORSE'S HEAD AND MANE, WITH THE 'BLAZE' IN THE SHAPE OF KENTUCKY. THE STYLIZED TEXT "BLUEGRASSANNIE A DREAMER'S EYE" APPEARS BELOW WITH A HUMAN EYE FORMING THE LETTER "I" IN THE WORD "ANNIE".

FOR DRAWINGS; MURALS; PAINTINGS; PORTRAITS (U.S. CLS. 2, 5, 22, 23, 29, 37, 38 AND 50).  
REBECCA SMITH, EXAMINING ATTORNEY

**CLASS 16—(Continued).**

SN 85-039,175. FWD MEDIA, INC., NEW YORK, NY. FILED 5-14-2010.

## Where learning gets animated

THE MARK CONSISTS OF STANDARD CHARACTERS WITHOUT CLAIM TO ANY PARTICULAR FONT, STYLE, SIZE, OR COLOR.

FOR PRINTED INSTRUCTIONAL, TEACHING AND EDUCATIONAL MATERIALS, NAMELY, LESSON PLANS, EXERCISE WORKSHEETS AND HANDOUTS AND REFERENCE MATERIALS USED IN CONNECTION WITH INSTRUCTION OF VARIOUS SUBJECTS, NAMELY, HEALTH, SCIENCE, MATHEMATICS, ART, MUSIC, LANGUAGE ARTS, HEALTH AND TECHNOLOGY INSTRUCTION (U.S. CLS. 2, 5, 22, 23, 29, 37, 38 AND 50).

MICHAEL LITZAU, EXAMINING ATTORNEY

SN 85-040,110. DELANEY, WILLIAM, DBA TEMAIR ASSOCIATES, ROSEVILLE, CA. AND DELANEY, TARA, DBA TEMAIR ASSOCIATES, ROSEVILLE, CA. FILED 5-17-2010.

## SOCIAL SENSE

THE MARK CONSISTS OF STANDARD CHARACTERS WITHOUT CLAIM TO ANY PARTICULAR FONT, STYLE, SIZE, OR COLOR.

FOR PRINTED EDUCATIONAL MATERIALS IN THE FIELD OF CHILD DEVELOPMENT (U.S. CLS. 2, 5, 22, 23, 29, 37, 38 AND 50).

DANNEAN HETZEL, EXAMINING ATTORNEY

SN 85-032,426. DESI CALENDARS LLC, ARLINGTON, VA. FILED 5-6-2010.



NO CLAIM IS MADE TO THE EXCLUSIVE RIGHT TO USE "CALENDARS", APART FROM THE MARK AS SHOWN.

THE COLOR(S) ORANGE, GREEN, BLUE, TEAL, AND RED IS/ARE CLAIMED AS A FEATURE OF THE MARK.

THE MARK CONSISTS OF THE WORD "DESI" IN ORANGE HALF MOON SHAPE FOLLOWED BY WORD "CALENDARS" IN GREEN HALF MOON SHAPE; BOTH OF THESE FORM A CIRCLE WITH A RED AND TEAL SWIRL IN THE MIDDLE; "WWW.DESICALENDARS.COM" AT BOTTOM IN BLUE.

THE ENGLISH TRANSLATION OF "DESI" IN THE MARK IS INDIAN.

FOR WALL CALENDARS (U.S. CLS. 2, 5, 22, 23, 29, 37, 38 AND 50).

FIRST USE 4-1-2010; IN COMMERCE 4-25-2010.  
RAUL CORDOVA, EXAMINING ATTORNEY

SN 85-044,999. THE ENERGY EXTENSION, INC., SEDONA, AZ. FILED 5-21-2010.

## LATTICELOGIC

THE MARK CONSISTS OF STANDARD CHARACTERS WITHOUT CLAIM TO ANY PARTICULAR FONT, STYLE, SIZE, OR COLOR.

OWNER OF U.S. REG. NO. 2,679,676.

FOR PRINTED INSTRUCTIONAL EDUCATIONAL TEACHING MATERIALS IN THE FIELD OF HUMAN ELECTROMAGNETIC FIELDS (U.S. CLS. 2, 5, 22, 23, 29, 37, 38 AND 50).

FIRST USE 6-16-2009; IN COMMERCE 6-16-2009.  
KELLEY WELLS, EXAMINING ATTORNEY

**CLASS 16—(Continued).**

SN 85-048,016. ARTE GRAFICO EDITORIAL ARGENTINO S.A., BUENOS AIRES, ARGENTINA, FILED 5-26-2010.



OWNER OF U.S. REG. NOS. 2,130,172, 2,130,173 AND 2,130,175.

THE COLOR(S) RED IS/ARE CLAIMED AS A FEATURE OF THE MARK.

THE MARK CONSISTS OF THE WORD "CLARIN" IN STYLIZED RED LETTERS FOLLOWED BY THE SILHOUETTE OF MAN PLAYING THE BUGLE ALL APPEARING IN THE COLOR RED.

THE ENGLISH TRANSLATION OF "CLARIN" IN THE MARK IS BUGLE.

FOR NEWSPAPERS OF GENERAL CIRCULATION AND MAGAZINES IN THE FIELD OF CURRENT EVENT NEWS (U.S. CLS. 2, 5, 22, 23, 29, 37, 38 AND 50).  
LEIGH LOWRY, EXAMINING ATTORNEY

**CLASS 16—(Continued).**

SN 85-078,812. HANDI QUILTER, INC., NORTH SALT LAKE, UT. FILED 7-6-2010.



OWNER OF U.S. REG. NOS. 2,920,821, 3,559,066 AND OTHERS.

NO CLAIM IS MADE TO THE EXCLUSIVE RIGHT TO USE "HANDY QUILTER", APART FROM THE MARK AS SHOWN.

THE MARK CONSISTS OF A STYLIZED IMAGE OF A NEEDLE AND THREAD TO THE LEFT OF THE WORDS "HANDI QUILTER", WITH THE THREAD CONTINUING BELOW THE WORDS AS A DASHED LINE.

FOR EDUCATIONAL BOOKS AND MANUALS ON QUILTING TECHNIQUES (U.S. CLS. 2, 5, 22, 23, 29, 37, 38 AND 50).

FIRST USE 5-3-2007; IN COMMERCE 5-3-2007.  
RONALD AIKENS, EXAMINING ATTORNEY

SN 85-088,108. CORPRON, ANNA D., NEW YORK, NY. FILED 7-19-2010.

SN 85-070,737. GLAXO GROUP LIMITED, GREENFORD, MIDDLESEX, UNITED KINGDOM, FILED 6-24-2010.

ASTHMA AIRWAYS & ANSWERS



THE COLOR(S) BLUE, LIGHT BLUE IS/ARE CLAIMED AS A FEATURE OF THE MARK.

THE MARK CONSISTS OF A STYLIZED "W" ABOVE THE LIGHT BLUE WORDING "THE WORKING PROOF". THE "W" IS COMPOSED OF SEVERAL ROWS OF ZIG-ZAGGING LINES THAT ALTERNATE COLORS. PORTIONS OF THE LINES THAT MOVE DIAGONALLY DOWN FROM LEFT TO RIGHT ARE BLUE, WHILE LINES MOVING DIAGONALLY UP ARE LIGHT BLUE.

FOR ART PRINTS (U.S. CLS. 2, 5, 22, 23, 29, 37, 38 AND 50).

FIRST USE 10-13-2009; IN COMMERCE 10-13-2009.  
CORY BOONE, EXAMINING ATTORNEY

THE MARK CONSISTS OF STANDARD CHARACTERS WITHOUT CLAIM TO ANY PARTICULAR FONT, STYLE, SIZE, OR COLOR.

NO CLAIM IS MADE TO THE EXCLUSIVE RIGHT TO USE "ASTHMA AIRWAYS", APART FROM THE MARK AS SHOWN.

FOR MAGAZINES FEATURING INFORMATION ON ASTHMA AND ALLERGIES (U.S. CLS. 2, 5, 22, 23, 29, 37, 38 AND 50).

DAVID TAYLOR, EXAMINING ATTORNEY

**CLASS 16—(Continued).**

SN 85-096,600. CRAIG KUNCE LLC, ONALASKA, WI. FILED 7-30-2010.

**Edrick the Inventor**

THE MARK CONSISTS OF STANDARD CHARACTERS WITHOUT CLAIM TO ANY PARTICULAR FONT, STYLE, SIZE, OR COLOR.

FOR PRINTED MATTER AND PAPER GOODS, NAMELY, CHILDREN'S BOOKS FEATURING CHARACTERS FROM ANIMATED, ACTION ADVENTURE, COMEDY AND/OR DRAMA FEATURES, CHILDREN'S BOOKS, COLORING BOOKS, CHILDREN'S ACTIVITY BOOKS; STATIONERY, WRITING PAPER, NOTEBOOKS, DIARIES, NOTE CARDS, GREETING CARDS, TRADING CARDS; PENS, PENCILS, PEN AND PENCIL CASES, CRAYONS, MARKERS, PAINTING SETS, DECALS, POSTERS; BOOK COVERS, BOOK MARKS, CALENDARS, GIFT WRAPPING PAPER; PAPER PARTY FAVORS, PRINTED PAPER PARTY INVITATIONS AND PAPER PARTY DECORATIONS, NAMELY, PAPER NAPKINS, PAPER TABLE CLOTHS (U.S. CLS. 2, 5, 22, 23, 29, 37, 38 AND 50).

FIRST USE 5-1-2010; IN COMMERCE 5-1-2010.  
LINDA M. KING, EXAMINING ATTORNEY

**CLASS 16—(Continued).**

SN 85-115,338. THE GARRAFON GROUP, DBA KIDNNECTED MAGAZINE, THE WOODLANDS, TX. FILED 8-25-2010.



THE MARK CONSISTS OF A STYLIZED REPRESENTATION OF THE WORD "KIDNNECTED" WITH A STYLIZED REPRESENTATION OF A HUMAN FORMING THE LETTER "T".

FOR MAGAZINES IN THE FIELD OF CHILDREN'S ENTERTAINMENT; MAGAZINES IN THE FIELD OF CHILDREN'S HEALTH (U.S. CLS. 2, 5, 22, 23, 29, 37, 38 AND 50).

FIRST USE 7-15-2010; IN COMMERCE 8-7-2010.  
ROBERT C. CLARK JR., EXAMINING ATTORNEY

SN 85-117,516. THE GARRAFON GROUP, DBA KIDNNECTED MAGAZINE, THE WOODLANDS, TX. FILED 8-27-2010.

SN 85-112,471. ORTHOWORLD, INC., CHAGRIN FALLS, OH. FILED 8-20-2010.

**ORTHO BIOCEUTICALS NOW**

THE MARK CONSISTS OF STANDARD CHARACTERS WITHOUT CLAIM TO ANY PARTICULAR FONT, STYLE, SIZE, OR COLOR.

OWNER OF U.S. REG. NOS. 2,435,191, 3,273,958 AND 3,575,463.

NO CLAIM IS MADE TO THE EXCLUSIVE RIGHT TO USE "ORTHO BIOCEUTICALS", APART FROM THE MARK AS SHOWN.

FOR PUBLICATIONS, NAMELY, BROCHURES, BOOKLETS, NEWSLETTERS AND ARTICLES IN THE FIELD OF THERAPEUTIC SOLUTIONS TO MUSCULOSKELETAL CONDITIONS AND DISEASES (U.S. CLS. 2, 5, 22, 23, 29, 37, 38 AND 50).

MICHELE SWAIN, EXAMINING ATTORNEY



THE MARK CONSISTS OF A STYLIZED DESIGN OF A MAN.

FOR MAGAZINES IN THE FIELD OF CHILDREN'S ENTERTAINMENT; MAGAZINES IN THE FIELD OF CHILDREN'S HEALTH (U.S. CLS. 2, 5, 22, 23, 29, 37, 38 AND 50).

FIRST USE 7-15-2010; IN COMMERCE 8-7-2010.  
ROBERT C. CLARK JR., EXAMINING ATTORNEY

**CLASS 16—(Continued).**

SN 85-119,779. EDUCATIONAL IDEAS, INC., DBA BALLARD & TIGHE, BREA, CA. FILED 8-31-2010.

**CAROUSEL OF IDEAS**

THE MARK CONSISTS OF STANDARD CHARACTERS WITHOUT CLAIM TO ANY PARTICULAR FONT, STYLE, SIZE, OR COLOR.

FOR EDUCATIONAL KITS SOLD AS A UNIT IN THE FIELD OF READING, WRITING AND UNDERSTANDING THE ENGLISH LANGUAGE CONSISTING PRIMARILY OF EDUCATIONAL BOOKS AND ALSO INCLUDING AN EDUCATIONAL CD-ROM; PRINTED MATERIALS, NAMELY, WORKBOOKS, WORKSHEETS AND CHARTS FOR TESTING AND ASSESSING THE LISTENING, SPEAKING, READING AND WRITING ABILITY OF INDIVIDUALS LEARNING THE ENGLISH LANGUAGE (U.S. CLS. 2, 5, 22, 23, 29, 37, 38 AND 50).

FIRST USE 7-0-1984; IN COMMERCE 7-0-1984.  
MICHELE SWAIN, EXAMINING ATTORNEY

**CLASS 16—(Continued).**

SN 85-125,863. GRIM LLC, MORGANTOWN, WV. FILED 9-9-2010.



THE COLOR(S) BLACK AND RED IS/ARE CLAIMED AS A FEATURE OF THE MARK.

THE MARK CONSISTS OF THE UPPER CASE LETTER "G" IN RED CENTERED WITHIN A RED BORDER UPON A BLACK BACKGROUND AND WITH THE HORIZONTAL LINE OF THE "G" BEING CONNECTED TO THE RED BORDER.

FOR ART PRINTS; GICLEE PRINTS; GRAPHIC FINE ART PRINTS; GRAPHIC PRINTS AND REPRESENTATIONS; POSTERS (U.S. CLS. 2, 5, 22, 23, 29, 37, 38 AND 50).

NATALIE POLZER, EXAMINING ATTORNEY

SN 85-125,875. GRIM LLC, MORGANTOWN, WV. FILED 9-9-2010.

**GRIM GRAPHIX**

THE MARK CONSISTS OF STANDARD CHARACTERS WITHOUT CLAIM TO ANY PARTICULAR FONT, STYLE, SIZE, OR COLOR.

NO CLAIM IS MADE TO THE EXCLUSIVE RIGHT TO USE "GRAPHIX", APART FROM THE MARK AS SHOWN.

FOR ART PRINTS; GICLEE PRINTS; GRAPHIC FINE ART PRINTS; GRAPHIC PRINTS AND REPRESENTATIONS; POSTERS (U.S. CLS. 2, 5, 22, 23, 29, 37, 38 AND 50).

NATALIE POLZER, EXAMINING ATTORNEY

SN 85-122,093. FREAKONOMICS, LLC, NEW YORK, NY. FILED 9-2-2010.

**Freakonomics**

THE MARK CONSISTS OF STANDARD CHARACTERS WITHOUT CLAIM TO ANY PARTICULAR FONT, STYLE, SIZE, OR COLOR.

FOR A SERIES OF BOOKS AND WRITTEN ARTICLES IN THE FIELD OF ECONOMICS, STATISTICS, POPULAR CULTURE, AND CURRENT AND HISTORIC EVENTS; STUDY GUIDES (U.S. CLS. 2, 5, 22, 23, 29, 37, 38 AND 50).

FIRST USE 4-12-2005; IN COMMERCE 4-12-2005.  
KATHLEEN LORENZO, EXAMINING ATTORNEY

SN 85-128,011. HIGHSMART NORTH AMERICA, DES MOINES, IA. FILED 9-13-2010.

**DRI-SMARTE**

THE MARK CONSISTS OF STANDARD CHARACTERS WITHOUT CLAIM TO ANY PARTICULAR FONT, STYLE, SIZE, OR COLOR.

FOR ABSORBENT PADS OF PAPER AND CELLULOSE FOR USE IN FOOD PACKAGING, NAMELY, FOR USE IN PACKAGING TRAY-PACKED MEAT, POULTRY, SEAFOOD AND PRODUCE (U.S. CLS. 2, 5, 22, 23, 29, 37, 38 AND 50).

REBECCA EISINGER, EXAMINING ATTORNEY

**CLASS 16—(Continued).**

SN 85-136,395. ABRAHAM, IBY, NEW YORK, NY. FILED 9-23-2010.

**Two Suitcases and a dream**

THE MARK CONSISTS OF STANDARD CHARACTERS WITHOUT CLAIM TO ANY PARTICULAR FONT, STYLE, SIZE, OR COLOR.

FOR A SERIES OF NON-FICTION BOOKS AND WRITTEN ARTICLES IN THE FIELDS OF BIOGRAPHIES AND PEOPLES' DREAMS (U.S. CLS. 2, 5, 22, 23, 29, 37, 38 AND 50).

MAUREEN DALL, EXAMINING ATTORNEY

SN 85-136,476. WILLIAM R. PETRO, DBA PETRO MOLD COMPANY, WATERFORD, PA. FILED 9-23-2010.

**MagiCast**

THE MARK CONSISTS OF STANDARD CHARACTERS WITHOUT CLAIM TO ANY PARTICULAR FONT, STYLE, SIZE, OR COLOR.

FOR MODELING COMPOUNDS; MODELING MATERIALS AND COMPOUNDS FOR USE BY CHILDREN (U.S. CLS. 2, 5, 22, 23, 29, 37, 38 AND 50).

FIRST USE 9-9-2010; IN COMMERCE 9-9-2010.  
STEPHANIE ALI, EXAMINING ATTORNEY

SN 85-136,497. WORDLY, AL, ORLANDO, FL. FILED 9-23-2010.



NO CLAIM IS MADE TO THE EXCLUSIVE RIGHT TO USE "FAT", APART FROM THE MARK AS SHOWN.

THE MARK CONSISTS OF A CIRCLE WITH THE WORD "PHAT" ON TOP IN ALL BOLD LETTERS AND THE WORD "KRUSHER" ON THE BOTTOM. INSIDE THAT CIRCLE IS ANOTHER CIRCLE THAT HAS AN ENCLOSED FIST THAT IS SQUEEZING FAT. THE FAT IS SEEPING OUT THROUGH THE ENCLOSED FIST.

FOR BOOKS IN THE FIELD OF FITNESS AND EXERCISE (U.S. CLS. 2, 5, 22, 23, 29, 37, 38 AND 50).

JOHN KELLY, EXAMINING ATTORNEY

**CLASS 16—(Continued).**

SN 85-137,293. HUNTER, LYNN, CLIFFSIDE PARK, NJ. FILED 9-24-2010.

**DOOPLES**

THE MARK CONSISTS OF STANDARD CHARACTERS WITHOUT CLAIM TO ANY PARTICULAR FONT, STYLE, SIZE, OR COLOR.

FOR A SERIES OF CHILDREN'S BOOKS AND PUBLICATIONS (U.S. CLS. 2, 5, 22, 23, 29, 37, 38 AND 50).

FIRST USE 9-20-2003; IN COMMERCE 9-20-2010.  
HEATHER SAPP, EXAMINING ATTORNEY

SN 85-138,205. METROSCAPE, LLC, GRETNA, LA. FILED 9-25-2010.



NO CLAIM IS MADE TO THE EXCLUSIVE RIGHT TO USE "GEOGRAPHIC INFORMATION SYSTEM" AND "LLC", APART FROM THE MARK AS SHOWN.

THE COLOR(S) RED, WHITE AND BLACK IS/ARE CLAIMED AS A FEATURE OF THE MARK.

THE MARK CONSISTS OF ALTERNATING RED AND WHITE QUADRANTS INSIDE A CIRCULAR TARGET SYMBOL. STARTING UPPER RIGHT QUADRANT IS WHITE, ALTERNATING BETWEEN RED AND WHITE GOING IN A CLOCKWISE DIRECTION. THE CIRCULAR BORDER AND CROSSHAIRS OF THE TARGET SYMBOL ARE BLACK. THE WORD "METROSCAPE LLC" STARTS IN THE LOWER RIGHT QUADRANT AND IS BLACK IN COLOR. THE WORDING "GEOGRAPHIC INFORMATION SYSTEM AT WORK" APPEARS BELOW THE WORD "METROSCAPE LLC" AND IS RED IN COLOR.

FOR GEOGRAPHICAL MAPS (U.S. CLS. 2, 5, 22, 23, 29, 37, 38 AND 50).

FIRST USE 2-28-2008; IN COMMERCE 2-28-2008.  
JEFFREY LOOK, EXAMINING ATTORNEY

SN 85-140,346. LOCAL HERO PUBLICATIONS, INC., CHICAGO, IL. FILED 9-28-2010.

**LOCAL HERO COUPONS**

NO CLAIM IS MADE TO THE EXCLUSIVE RIGHT TO USE "LOCAL" AND "COUPONS", APART FROM THE MARK AS SHOWN.

THE MARK CONSISTS OF THE STYLIZED TEXT "LOCAL HERO COUPONS".

FOR COUPON BOOKS; COUPONS (U.S. CLS. 2, 5, 22, 23, 29, 37, 38 AND 50).

JOHN GARTNER, EXAMINING ATTORNEY

**CLASS 16—(Continued).**

SN 85-140,406. PRETTY FLUFFY CHICKEN PRODUCTIONS, LLC, EDINA, MN. FILED 9-28-2010.

**EAT YOUR DRINK**

THE MARK CONSISTS OF STANDARD CHARACTERS WITHOUT CLAIM TO ANY PARTICULAR FONT, STYLE, SIZE, OR COLOR.

NO CLAIM IS MADE TO THE EXCLUSIVE RIGHT TO USE "DRINK", APART FROM THE MARK AS SHOWN.

FOR BOOKS IN THE FIELD OF ENTERTAINING, COCKTAILS, COCKTAIL RECIPES, PHOTOS, AND MENU PLANNING; CALENDARS; JOURNALS CONCERNING RECIPES, ENTERTAINING, COCKTAILS, COCKTAIL RECIPES, PHOTOS, AND MENU PLANNING; RECIPE BOOKS (U.S. CLS. 2, 5, 22, 23, 29, 37, 38 AND 50).

WON TEAK OH, EXAMINING ATTORNEY

---

SN 85-143,895. BLATT, MARILYN, NORTH MIAMI BEACH, FL. FILED 10-3-2010.

**WILLIE WRITEWELL**

THE MARK CONSISTS OF STANDARD CHARACTERS WITHOUT CLAIM TO ANY PARTICULAR FONT, STYLE, SIZE, OR COLOR.

THE NAME "WILLIE WRITEWELL" DOES NOT IDENTIFY A LIVING INDIVIDUAL.

FOR EDUCATIONAL KITS SOLD AS A UNIT IN THE FIELD OF CREATIVE WRITING CONSISTING PRIMARILY OF EDUCATIONAL BOOKS, A DVD AND T-SHIRT (U.S. CLS. 2, 5, 22, 23, 29, 37, 38 AND 50).

CURTIS FRENCH, EXAMINING ATTORNEY

---

SN 85-146,046. JOSEPH MOSELLO, MORGANVILLE, NJ. FILED 10-6-2010.

**PRO CHOPS**

THE MARK CONSISTS OF STANDARD CHARACTERS WITHOUT CLAIM TO ANY PARTICULAR FONT, STYLE, SIZE, OR COLOR.

FOR SHEET MUSIC (U.S. CLS. 2, 5, 22, 23, 29, 37, 38 AND 50).

FIRST USE 10-1-2006; IN COMMERCE 10-1-2008.  
ANDREA HACK, EXAMINING ATTORNEY

**CLASS 16—(Continued).**

SN 85-147,056. DCREATIONS, LLC, MASON, OH. FILED 10-7-2010.

**BLINX**

THE MARK CONSISTS OF STANDARD CHARACTERS WITHOUT CLAIM TO ANY PARTICULAR FONT, STYLE, SIZE, OR COLOR.

FOR MEMORY BOOKS; ANNIVERSARY BOOKS; BABY BOOKS; BIRTHDAY BOOKS; ENGAGEMENT BOOKS; PICTURE BOOKS; BOOKS IN THE FIELD OF PERSONALIZED PICTURE BOOKS; PUBLICATIONS, NAMELY, BOOKS IN THE FIELDS OF PERSONALIZED PICTURE BOOKS AND PERSONALIZED MEMORY BOOKS; SCRAPBOOKS; SCRAPBOOKS RELATED TO SORORITY, FRATERNITY, OR COLLEGE EVENTS; YEARBOOKS; YEARBOOKS RELATED TO SORORITY, FRATERNITY, OR COLLEGE EVENTS; PHOTO JOURNALS; PHOTO DIARIES; WEDDING PHOTO ALBUMS (U.S. CLS. 2, 5, 22, 23, 29, 37, 38 AND 50).

SUNG IN, EXAMINING ATTORNEY

---

SN 85-147,084. DCREATIONS, LLC, MASON, OH. FILED 10-7-2010.

**LIFEBLINX**

THE MARK CONSISTS OF STANDARD CHARACTERS WITHOUT CLAIM TO ANY PARTICULAR FONT, STYLE, SIZE, OR COLOR.

FOR MEMORY BOOKS; ANNIVERSARY BOOKS; BABY BOOKS; BIRTHDAY BOOKS; ENGAGEMENT BOOKS; PICTURE BOOKS; BOOKS IN THE FIELD OF PERSONALIZED PICTURE BOOKS; PUBLICATIONS, NAMELY, BOOKS IN THE FIELDS OF PERSONALIZED PICTURE BOOKS AND PERSONALIZED MEMORY BOOKS; SCRAPBOOKS; SCRAPBOOKS RELATED TO SORORITY, FRATERNITY, OR COLLEGE EVENTS; YEARBOOKS; YEARBOOKS RELATED TO SORORITY, FRATERNITY, OR COLLEGE EVENTS; PHOTO JOURNALS; PHOTO DIARIES; WEDDING PHOTO ALBUMS (U.S. CLS. 2, 5, 22, 23, 29, 37, 38 AND 50).

SUNG IN, EXAMINING ATTORNEY

**CLASS 16—(Continued).**

SN 85-147,990. 1-2-3 SUCCEED, MOUNT ARLINGTON, NJ. FILED 10-7-2010.

## 1-2-3 Succeed

THE MARK CONSISTS OF STANDARD CHARACTERS WITHOUT CLAIM TO ANY PARTICULAR FONT, STYLE, SIZE, OR COLOR.

OWNER OF U.S. REG. NO. 3,866,836.  
FOR PRINTED PLANNERS, AGENDAS, APPOINTMENT BOOKS, AND CALENDARS; EDUCATIONAL PUBLICATIONS, NAMELY, STUDENT PRINTED PLANNERS, STUDENT AGENDAS, STUDENT APPOINTMENT BOOKS, STUDENT CALENDARS, STUDY GUIDES, PRINTED ORGANIZATIONAL GUIDES, AND PRINTED MOTIVATIONAL GUIDES (U.S. CLS. 2, 5, 22, 23, 29, 37, 38 AND 50).

FIRST USE 12-28-2009; IN COMMERCE 12-28-2009.  
BRENDAN REGAN, EXAMINING ATTORNEY

SN 85-149,235. RAYNOR, BROOKE, DBA RAYNORSHINE-DESIGNS LTD., CYPRESS, CA. FILED 10-10-2010.

**RAYNORSHINEDESIGNS Ltd.**

NO CLAIM IS MADE TO THE EXCLUSIVE RIGHT TO USE "LTD.", APART FROM THE MARK AS SHOWN.

THE MARK CONSISTS OF "RAYNORSHINEDESIGNS LTD." IS WRITTEN IN BORDEAUX ROMAN BOLD FONT. THE LETTERS "R", "S", "D" ARE TWO TIMES THE SIZE OF THE OTHER LETTERS.

FOR PRINTED CALENDARS; WALL CALENDARS (U.S. CLS. 2, 5, 22, 23, 29, 37, 38 AND 50).  
JOSETTE BEVERLY, EXAMINING ATTORNEY

SN 85-150,234. THE WILD ROSE PRESS, ADAMS BASIN, NY. FILED 10-12-2010.

## The Wild Rose Press

THE MARK CONSISTS OF STANDARD CHARACTERS WITHOUT CLAIM TO ANY PARTICULAR FONT, STYLE, SIZE, OR COLOR.

NO CLAIM IS MADE TO THE EXCLUSIVE RIGHT TO USE "PRESS", APART FROM THE MARK AS SHOWN.  
FOR ROMANCE NOVELS (U.S. CLS. 2, 5, 22, 23, 29, 37, 38 AND 50).

FIRST USE 5-1-2006; IN COMMERCE 5-5-2006.  
RONALD MCMORROW, EXAMINING ATTORNEY

**CLASS 16—(Continued).**

SN 85-150,420. DEJESUS, NOEL, DBA INK & CONCRETE PRODUCTIONS, TUSCALOOSA, AL. FILED 10-12-2010.



**INK&CONCRETE**  
PRODUCTIONS

NO CLAIM IS MADE TO THE EXCLUSIVE RIGHT TO USE "PRODUCTIONS", APART FROM THE MARK AS SHOWN.

THE COLOR(S) BLACK AND WHITE IS/ARE CLAIMED AS A FEATURE OF THE MARK.

THE MARK CONSISTS OF A SILHOUETTE IN BLACK OF A GROUP OF PEOPLE STANDING BEHIND A BARRICADE. BENEATH THE DESIGN IS THE WORDING "INK & CONCRETE PRODUCTIONS" IN STYLIZED FONT. THE FOREGOING ELEMENTS APPEAR ON A WHITE BACKGROUND.

FOR A SERIES OF BOOKS AND WRITTEN ARTICLES IN THE FIELD OF URBAN LITERATURE (U.S. CLS. 2, 5, 22, 23, 29, 37, 38 AND 50).

STEVEN PEREZ, EXAMINING ATTORNEY

SN 85-151,269. MICHAEL CLARKE, HORSHAM, PA. FILED 10-13-2010.

**MAZEMAN**

THE MARK CONSISTS OF STANDARD CHARACTERS WITHOUT CLAIM TO ANY PARTICULAR FONT, STYLE, SIZE, OR COLOR.

FOR PRINTED CROSSWORD PUZZLES, PRINTED MAZE PUZZLES, PUZZLE BOOKS AND CHILDREN'S ACTIVITY BOOKS (U.S. CLS. 2, 5, 22, 23, 29, 37, 38 AND 50).

FIRST USE 1-15-2006; IN COMMERCE 7-3-2008.  
KATHY DE JONGE, EXAMINING ATTORNEY



**CLASS 16—(Continued).**

SN 85-152,996. BRYANT HERITAGE LLC, HOUSTON, TX.  
FILED 10-14-2010.



NO CLAIM IS MADE TO THE EXCLUSIVE RIGHT TO USE "MAGAZINE", APART FROM THE MARK AS SHOWN. THE COLOR(S) YELLOW, PINK, WHITE AND BLACK IS/ARE CLAIMED AS A FEATURE OF THE MARK.

THE MARK CONSISTS OF AN OUTER CIRCLE AROUND AN INNER CIRCLE. THE OUTER CIRCLE HAS A YELLOW BACKGROUND AND BLACK OUTLINE. THE OUTER CIRCLE INCLUDES SEVERAL MENTIONS OF THE PHRASE "HOW YOU LOOK AT LIFE IS THE KEY." IN BLACK ENCIRCLING THE INNER CIRCLE. THE INNER CIRCLE HAS A PINK BACKGROUND. THE STYLIZED WORDS "ISOKE MAGAZINE" ARE CENTERED WITHIN THE INNER CIRCLE. THE STYLIZED WORDS ARE IN THE COLOR WHITE. THE PHRASE "A BEAUTIFUL GIFT FROM GOD." REPEATED TWICE ENCIRCLES THE LETTER "O" IN "ISOKE". "A BEAUTIFUL GIFT FROM GOD." IS IN THE COLOR YELLOW. THE CHARACTERS "EYE-ZOE-KEY" ARE CENTERED BELOW THE STYLIZED WORD "MAGAZINE". "EYE-ZOE-KEY" IS IN THE COLOR YELLOW.

THE WORDING "ISOKE" HAS NO MEANING IN A FOREIGN LANGUAGE.

FOR MAGAZINE PAPER; MAGAZINES FEATURING ARTICLES PROMOTING SPIRITUAL HEALTH, PHYSICAL HEALTH AND AWARENESS, HEALTHY RELATIONSHIPS, FINANCIAL SOUNDNESS, ELEGANT BEAUTY TIPS, STYLISH FASHION, WHOLESOME MUSIC, AND INFORMATION TO CATER TO THE TOTAL PRINCESS IN EACH AND EVERY BLACK GIRL; MAGAZINES IN THE FIELD OF SPIRITUAL HEALTH, PHYSICAL HEALTH AND AWARENESS, HEALTHY RELATIONSHIPS, FINANCIAL SOUNDNESS, ELEGANT BEAUTY TIPS, STYLISH FASHION, AND WHOLESOME MUSIC (U.S. CLS. 2, 5, 22, 23, 29, 37, 38 AND 50).

FIRST USE 9-29-2010; IN COMMERCE 9-29-2010.

ROBIN MITTLER, EXAMINING ATTORNEY

**CLASS 16—(Continued).**

SN 85-153,492. COSMOS SOCCER CLUB LLC, NEW YORK, NY. FILED 10-15-2010.

**COSMOS COUNTRY**

THE MARK CONSISTS OF STANDARD CHARACTERS WITHOUT CLAIM TO ANY PARTICULAR FONT, STYLE, SIZE, OR COLOR.

OWNER OF U.S. REG. NOS. 3,642,942, 3,642,950 AND OTHERS.

FOR MAGAZINES IN THE FIELD OF SOCCER, POSTERS, SCORE BOOKS, SCORE CARDS, SOUVENIR PROGRAMS IN THE FIELD OF SOCCER, CALENDARS, PRINTED INSTRUCTIONAL AND TEACHING MATERIAL IN THE FIELD OF SOCCER, PAPER PENNANTS, PAPER COASTERS, PRINTED MATTER, NAMELY, BOOKS, PAMPHLETS, BROCHURES AND YEARBOOKS IN THE FIELD OF SOCCER (U.S. CLS. 2, 5, 22, 23, 29, 37, 38 AND 50).

MICHAEL TANNER, EXAMINING ATTORNEY

SN 85-153,964. MANDAR, MARTINE, LE CHESNAY, FRANCE, FILED 10-15-2010.

**FASHION-IT**

THE MARK CONSISTS OF STANDARD CHARACTERS WITHOUT CLAIM TO ANY PARTICULAR FONT, STYLE, SIZE, OR COLOR.

OWNER OF FRANCE REG. NO. 023189432, DATED 10-17-2002. EXPIRES 10-17-2012.

OWNER OF U.S. REG. NO. 2,878,645.

FOR STATIONERY, ADHESIVES IN THE FORM OF TAPE FOR STATIONERY; OFFICE REQUISITES, EXCEPT FURNITURE, NAMELY, CORRECTING FLUID FOR TYPE, ENVELOPE SEALING MACHINES, PUNCHES, RUBBER BANDS, STAPLERS, DISPENSERS FOR ADHESIVE TAPES AND NOTE-PAD DISPENSERS, EACH FOR STATIONERY USE; ADHESIVE TAPES FOR STATIONERY PURPOSES; SCHOOL AND OFFICE SUPPLIES, NAMELY, STATIONERY (U.S. CLS. 2, 5, 22, 23, 29, 37, 38 AND 50).

ROBIN MITTLER, EXAMINING ATTORNEY

**CLASS 16—(Continued).**

SN 85-154,660. RECKLESS RUNNING LLC, KNOXVILLE, TN. FILED 10-18-2010.

## Run Culture

THE MARK CONSISTS OF STANDARD CHARACTERS WITHOUT CLAIM TO ANY PARTICULAR FONT, STYLE, SIZE, OR COLOR.

NO CLAIM IS MADE TO THE EXCLUSIVE RIGHT TO USE "RUN", APART FROM THE MARK AS SHOWN.

FOR MAGAZINE COLUMNS ABOUT RUNNING AND EXERCISE HEALTH; MAGAZINES FEATURING RUNNING AND EXERCISE HEALTH; MAGAZINES IN THE FIELD OF RUNNING AND EXERCISE HEALTH (U.S. CLS. 2, 5, 22, 23, 29, 37, 38 AND 50).

PATRICIA EVANKO, EXAMINING ATTORNEY

SN 85-155,038. WELCH, JENNIFER, BELLEAIR BLUFFS, FL. FILED 10-18-2010.

## KEY WESCUE

THE MARK CONSISTS OF STANDARD CHARACTERS WITHOUT CLAIM TO ANY PARTICULAR FONT, STYLE, SIZE, OR COLOR.

FOR PRINTED MATERIAL, NAMELY, STICKERS, BUMPER STICKERS, POST-CARDS, STATIONERY AND IRON-ON TRANSFERS NOT OF TEXTILE (U.S. CLS. 2, 5, 22, 23, 29, 37, 38 AND 50).

PAM WILLIS, EXAMINING ATTORNEY

SN 85-155,902. AGC, LLC, CLEVELAND, OH. FILED 10-19-2010.



NO CLAIM IS MADE TO THE EXCLUSIVE RIGHT TO USE "COLLAGE INTERNATIONAL", APART FROM THE MARK AS SHOWN.

THE COLOR(S) GOLDEN BROWN IS/ARE CLAIMED AS A FEATURE OF THE MARK.

THE MARK CONSISTS OF THE WORDS "COLLAGE INTERNATIONAL" IN GOLDEN BROWN. A GIFT BOX IN GOLDEN BROWN SURROUNDS THE LETTER "A" IN THE WORD "COLLAGE" WITH A BOW ON TOP. THE COLOR WHITE REPRESENTS BACKGROUND AND IS NOT PART OF THE MARK.

FOR GIFT BAGS; GIFT WRAP PAPER; GREETING CARDS (U.S. CLS. 2, 5, 22, 23, 29, 37, 38 AND 50).

MARK SHINER, EXAMINING ATTORNEY

**CLASS 16—(Continued).**

SN 85-156,686. NO TEARS LEARNING, INC., DBA HANDWRITING WITHOUT TEARS, CABIN JOHN, MD. FILED 10-20-2010.

## ABC TOUCH & FLIP CARDS

THE MARK CONSISTS OF STANDARD CHARACTERS WITHOUT CLAIM TO ANY PARTICULAR FONT, STYLE, SIZE, OR COLOR.

NO CLAIM IS MADE TO THE EXCLUSIVE RIGHT TO USE "CARDS", APART FROM THE MARK AS SHOWN.

FOR EDUCATIONAL KITS SOLD AS A UNIT COMPRISED OF SETS OF PRINTED FLASH CARD DECKS AND PRINTED GUIDES FOR TEACHING YOUNG CHILDREN LETTER RECOGNITION AND LETTER CHARACTERISTICS TO PROMOTE LITERACY DEVELOPMENT (U.S. CLS. 2, 5, 22, 23, 29, 37, 38 AND 50).

JAMES LOVELACE, EXAMINING ATTORNEY

SN 85-156,700. NO TEARS LEARNING, INC., DBA HANDWRITING WITHOUT TEARS, CABIN JOHN, MD. FILED 10-20-2010.

## 123 TOUCH & FLIP CARDS

THE MARK CONSISTS OF STANDARD CHARACTERS WITHOUT CLAIM TO ANY PARTICULAR FONT, STYLE, SIZE, OR COLOR.

NO CLAIM IS MADE TO THE EXCLUSIVE RIGHT TO USE "CARDS", APART FROM THE MARK AS SHOWN.

FOR EDUCATIONAL KITS SOLD AS A UNIT COMPRISED OF SETS OF PRINTED FLASH CARD DECKS AND PRINTED GUIDES HAVING ILLUSTRATIONS AND ACTIVITIES FOR TEACHING YOUNG CHILDREN NUMBER RECOGNITION AND NUMBER CHARACTERISTICS THAT PROMOTE EARLY MATH READINESS (U.S. CLS. 2, 5, 22, 23, 29, 37, 38 AND 50).

JAMES LOVELACE, EXAMINING ATTORNEY

SN 85-159,553. BOOK GLOVE LLC, HONOLULU, HI. FILED 10-22-2010.

## BOOK GLOVE

THE MARK CONSISTS OF STANDARD CHARACTERS WITHOUT CLAIM TO ANY PARTICULAR FONT, STYLE, SIZE, OR COLOR.

NO CLAIM IS MADE TO THE EXCLUSIVE RIGHT TO USE "BOOK", APART FROM THE MARK AS SHOWN.

FOR PROTECTIVE COVERS FOR BOOKS (U.S. CLS. 2, 5, 22, 23, 29, 37, 38 AND 50).

FIRST USE 9-18-2009; IN COMMERCE 9-18-2009.

HOWARD B. LEVINE, EXAMINING ATTORNEY

**CLASS 16—(Continued).**

SN 85-162,467. HALL OF TYRANNUS MISSION, THE, LOS ANGELES, CA. FILED 10-27-2010.

The logo features the words "TIEMPO con Dios es Vida Viva" in a mix of fonts. "TIEMPO" is in a bold, sans-serif font. "con" is in a small, lowercase font. "Dios es" is in a cursive script. "Vida Viva" is in a large, bold, sans-serif font with a decorative flourish under the "V" of "Viva".

OWNER OF U.S. REG. NO. 3,812,144.  
THE MARK CONSISTS OF THE WORDING "TIEMPO CON DIOS ES VIDA VIVA" IN STYLIZED DESIGN.  
THE ENGLISH TRANSLATION OF "TIEMPO CON DIOS ES VIDA VIVA" IN THE MARK IS TIME WITH GOD IS LIVING LIFE.  
FOR PRINTED PERIODICALS IN THE FIELD OF CHRISTIANITY (U.S. CLS. 2, 5, 22, 23, 29, 37, 38 AND 50).  
FIRST USE 12-1-2009; IN COMMERCE 12-1-2009.  
KIM MONINGHOFF, EXAMINING ATTORNEY

SN 85-166,915. GEORGIA-PACIFIC CONSUMER PRODUCTS LP, ATLANTA, GA. FILED 11-2-2010.

A stylized, bold letter 'Q' with a thick stroke and a small tail at the bottom right.

OWNER OF U.S. REG. NOS. 3,463,460, 3,642,213 AND OTHERS.  
THE MARK CONSISTS OF A STYLIZED LETTER Q.  
FOR BATHROOM TISSUE (U.S. CLS. 2, 5, 22, 23, 29, 37, 38 AND 50).  
MICHAEL WIENER, EXAMINING ATTORNEY

SN 85-169,398. TRI-C PUBLICATIONS, INC., GRAND RAPIDS, MI. FILED 11-4-2010.

## SUMMER SKILLS

THE MARK CONSISTS OF STANDARD CHARACTERS WITHOUT CLAIM TO ANY PARTICULAR FONT, STYLE, SIZE, OR COLOR.  
NO CLAIM IS MADE TO THE EXCLUSIVE RIGHT TO USE "SKILLS", APART FROM THE MARK AS SHOWN.  
FOR PRINTED INSTRUCTIONAL AND TEACHING MATERIALS IN SUBJECTS RELATED TO ELEMENTARY AND SECONDARY EDUCATION LEVELS (U.S. CLS. 2, 5, 22, 23, 29, 37, 38 AND 50).  
FIRST USE 10-29-1998; IN COMMERCE 10-29-1998.  
KAREN K. BUSH, EXAMINING ATTORNEY

**CLASS 16—(Continued).**

SN 85-170,912. YAFA PEN COMPANY, CANOGA PARK, CA. FILED 11-6-2010.

## ONE TOUCH

THE MARK CONSISTS OF STANDARD CHARACTERS WITHOUT CLAIM TO ANY PARTICULAR FONT, STYLE, SIZE, OR COLOR.  
FOR WRITING INSTRUMENTS (U.S. CLS. 2, 5, 22, 23, 29, 37, 38 AND 50).  
MORGAN WYNNE, EXAMINING ATTORNEY

SN 85-171,058. OPPERDAHL PATENT LAW FIRM LLC, DILLON, CO. FILED 11-7-2010.

## Penaya

THE MARK CONSISTS OF STANDARD CHARACTERS WITHOUT CLAIM TO ANY PARTICULAR FONT, STYLE, SIZE, OR COLOR.  
FOR NON-FICTION BOOKS ON A VARIETY OF TOPICS (U.S. CLS. 2, 5, 22, 23, 29, 37, 38 AND 50).  
FIRST USE 12-1-2010; IN COMMERCE 12-1-2010.  
REBECCA SMITH, EXAMINING ATTORNEY

SN 85-172,585. UNIVERSAL CHURCH, THE, NEWARK, NJ. FILED 11-9-2010.

## SUCCEED IN LIFE

THE MARK CONSISTS OF STANDARD CHARACTERS WITHOUT CLAIM TO ANY PARTICULAR FONT, STYLE, SIZE, OR COLOR.  
OWNER OF U.S. REG. NO. 3,549,776.  
FOR NEWSLETTERS, INFORMATIONAL BROCHURES, AND A SERIES OF BOOKS ALL ABOUT RELIGIOUS BELIEFS AND PRACTICES (U.S. CLS. 2, 5, 22, 23, 29, 37, 38 AND 50).  
FIRST USE 3-18-2008; IN COMMERCE 3-18-2008.  
DAVID HOFFMAN, EXAMINING ATTORNEY

**CLASS 16—(Continued).**

SN 85-173,658. AMERICAN BIBLE SOCIETY, NEW YORK, NY. FILED 11-10-2010.

**UNCOVER THE WORD**

THE MARK CONSISTS OF STANDARD CHARACTERS WITHOUT CLAIM TO ANY PARTICULAR FONT, STYLE, SIZE, OR COLOR.

FOR BIBLES, BOOKLETS, BROCHURES, STUDY GUIDES, NEWSLETTERS, INFORMATIONAL FLYERS, AND PRINTED EDUCATIONAL MATERIALS, ALL IN THE FIELDS OF THE BIBLE, CHRISTIANITY, RELIGION, THEOLOGY, SPIRITUALITY, ETHICS, VALUES, AND APPLICATION OF THE BIBLE TO INDIVIDUAL LIVES, THE MARKETPLACE, AND THE BROADER CULTURE; STICKERS, POSTERS, PENS (U.S. CLS. 2, 5, 22, 23, 29, 37, 38 AND 50).

MARC LEIPZIG, EXAMINING ATTORNEY

SN 85-175,519. BALANCED VIEW, MILL VALLEY, CA. FILED 11-12-2010.

**Great Freedom**

THE MARK CONSISTS OF STANDARD CHARACTERS WITHOUT CLAIM TO ANY PARTICULAR FONT, STYLE, SIZE, OR COLOR.

FOR EDUCATIONAL PUBLICATIONS, NAMELY, PAMPHLETS IN THE FIELDS OF BALANCED LIVING (U.S. CLS. 2, 5, 22, 23, 29, 37, 38 AND 50).

GISELLE AGOSTO, EXAMINING ATTORNEY

SN 85-175,553. BALANCED VIEW, MILL VALLEY, CA. FILED 11-12-2010.

**Great Freedom Center**

THE MARK CONSISTS OF STANDARD CHARACTERS WITHOUT CLAIM TO ANY PARTICULAR FONT, STYLE, SIZE, OR COLOR.

FOR EDUCATIONAL PUBLICATIONS, NAMELY, PAMPHLETS IN THE FIELDS OF BALANCED LIVING (U.S. CLS. 2, 5, 22, 23, 29, 37, 38 AND 50).

GISELLE AGOSTO, EXAMINING ATTORNEY

**CLASS 16—(Continued).**

SN 85-175,572. BALANCED VIEW, MILL VALLEY, CA. FILED 11-12-2010.

**Short Moments**

THE MARK CONSISTS OF STANDARD CHARACTERS WITHOUT CLAIM TO ANY PARTICULAR FONT, STYLE, SIZE, OR COLOR.

FOR EDUCATIONAL PUBLICATIONS, NAMELY, PAMPHLETS IN THE FIELDS OF BALANCED LIVING (U.S. CLS. 2, 5, 22, 23, 29, 37, 38 AND 50).

GISELLE AGOSTO, EXAMINING ATTORNEY

SN 85-175,579. BALANCED VIEW, MILL VALLEY, CA. FILED 11-12-2010.

**Short Moments, Many Times**

THE MARK CONSISTS OF STANDARD CHARACTERS WITHOUT CLAIM TO ANY PARTICULAR FONT, STYLE, SIZE, OR COLOR.

FOR EDUCATIONAL PUBLICATIONS, NAMELY, PAMPHLETS IN THE FIELDS OF BALANCED LIVING (U.S. CLS. 2, 5, 22, 23, 29, 37, 38 AND 50).

GISELLE AGOSTO, EXAMINING ATTORNEY

SN 85-175,586. BALANCED VIEW, MILL VALLEY, CA. FILED 11-12-2010.

**Short Moments of Clarity,  
Many Times, Become  
Continuous**

THE MARK CONSISTS OF STANDARD CHARACTERS WITHOUT CLAIM TO ANY PARTICULAR FONT, STYLE, SIZE, OR COLOR.

FOR EDUCATIONAL PUBLICATIONS, NAMELY, PAMPHLETS IN THE FIELDS OF BALANCED LIVING (U.S. CLS. 2, 5, 22, 23, 29, 37, 38 AND 50).

GISELLE AGOSTO, EXAMINING ATTORNEY

**CLASS 16—(Continued).**

SN 85-175,589. BALANCED VIEW, MILL VALLEY, CA. FILED 11-12-2010.

**Short Moments of Awareness, Many Times, Become Continuous**

THE MARK CONSISTS OF STANDARD CHARACTERS WITHOUT CLAIM TO ANY PARTICULAR FONT, STYLE, SIZE, OR COLOR.  
FOR EDUCATIONAL PUBLICATIONS, NAMELY, PAMPHLETS IN THE FIELDS OF BALANCED LIVING (U.S. CLS. 2, 5, 22, 23, 29, 37, 38 AND 50).  
GISELLE AGOSTO, EXAMINING ATTORNEY

**CLASS 16—(Continued).**

SN 85-175,610. BALANCED VIEW, MILL VALLEY, CA. FILED 11-12-2010.

**Lavender Fields Forever**

THE MARK CONSISTS OF STANDARD CHARACTERS WITHOUT CLAIM TO ANY PARTICULAR FONT, STYLE, SIZE, OR COLOR.  
FOR EDUCATIONAL PUBLICATIONS, NAMELY, PAMPHLETS IN THE FIELDS OF BALANCED LIVING (U.S. CLS. 2, 5, 22, 23, 29, 37, 38 AND 50).  
GISELLE AGOSTO, EXAMINING ATTORNEY

SN 85-175,592. BALANCED VIEW, MILL VALLEY, CA. FILED 11-12-2010.

**Short Moments of Clarity, Many Times, Become Automatic**

THE MARK CONSISTS OF STANDARD CHARACTERS WITHOUT CLAIM TO ANY PARTICULAR FONT, STYLE, SIZE, OR COLOR.  
FOR EDUCATIONAL PUBLICATIONS, NAMELY, PAMPHLETS IN THE FIELDS OF BALANCED LIVING (U.S. CLS. 2, 5, 22, 23, 29, 37, 38 AND 50).  
GISELLE AGOSTO, EXAMINING ATTORNEY

SN 85-175,618. BALANCED VIEW, MILL VALLEY, CA. FILED 11-12-2010.

**For the Benefit of All**

THE MARK CONSISTS OF STANDARD CHARACTERS WITHOUT CLAIM TO ANY PARTICULAR FONT, STYLE, SIZE, OR COLOR.  
FOR EDUCATIONAL PUBLICATIONS, NAMELY, PAMPHLETS IN THE FIELDS OF BALANCED LIVING (U.S. CLS. 2, 5, 22, 23, 29, 37, 38 AND 50).  
GISELLE AGOSTO, EXAMINING ATTORNEY

SN 85-175,602. BALANCED VIEW, MILL VALLEY, CA. FILED 11-12-2010.

**Short Moments of Awareness, Many Times, Become Automatic**

THE MARK CONSISTS OF STANDARD CHARACTERS WITHOUT CLAIM TO ANY PARTICULAR FONT, STYLE, SIZE, OR COLOR.  
FOR EDUCATIONAL PUBLICATIONS, NAMELY, PAMPHLETS IN THE FIELDS OF BALANCED LIVING (U.S. CLS. 2, 5, 22, 23, 29, 37, 38 AND 50).  
GISELLE AGOSTO, EXAMINING ATTORNEY

SN 85-175,630. BALANCED VIEW, MILL VALLEY, CA. FILED 11-12-2010.

**Four Comforts**

THE MARK CONSISTS OF STANDARD CHARACTERS WITHOUT CLAIM TO ANY PARTICULAR FONT, STYLE, SIZE, OR COLOR.  
FOR EDUCATIONAL PUBLICATIONS, NAMELY, PAMPHLETS IN THE FIELDS OF BALANCED LIVING (U.S. CLS. 2, 5, 22, 23, 29, 37, 38 AND 50).  
GISELLE AGOSTO, EXAMINING ATTORNEY

**CLASS 16—(Continued).**

SN 85-175,639. BALANCED VIEW, MILL VALLEY, CA. FILED 11-12-2010.

## Four Mainstays

THE MARK CONSISTS OF STANDARD CHARACTERS WITHOUT CLAIM TO ANY PARTICULAR FONT, STYLE, SIZE, OR COLOR.

FOR EDUCATIONAL PUBLICATIONS, NAMELY, PAMPHLETS IN THE FIELDS OF BALANCED LIVING (U.S. CLS. 2, 5, 22, 23, 29, 37, 38 AND 50).  
GISELLE AGOSTO, EXAMINING ATTORNEY

SN 85-175,826. CLUB CONCIERGE CORP., TOKYO, JAPAN, FILED 11-12-2010.

*Club Concierge*

THE MARK CONSISTS OF THE WORDS "CLUB CONCIERGE" IN A STYLIZED FONT.

FOR MAGAZINES IN THE FIELD OF TRAVEL, FINE FOOD, SPORTS, MUSIC, HEALTH, JEWELRY, WATCHES, SCHOOLS AND EDUCATION, AND THEATRICAL ENTERTAINMENT (U.S. CLS. 2, 5, 22, 23, 29, 37, 38 AND 50).

MATTHEW EINSTEIN, EXAMINING ATTORNEY

SN 85-175,970. YAMAGUCHI, ROY, HONOLULU, HI. FILED 11-12-2010.

## Aloha Inside

THE MARK CONSISTS OF STANDARD CHARACTERS WITHOUT CLAIM TO ANY PARTICULAR FONT, STYLE, SIZE, OR COLOR.

THE ENGLISH TRANSLATION OF "ALOHA" IN THE MARK IS "HELLO", "GOODBYE" AND "LOVE".

FOR DECORATIVE STICKERS FOR USE ON THE OUTSIDE OF PACKAGES AND GIFTS (U.S. CLS. 2, 5, 22, 23, 29, 37, 38 AND 50).

SAMUEL E. SHARPER JR., EXAMINING ATTORNEY

**CLASS 16—(Continued).**

SN 85-176,169. PRIME ADVERTISING, LLC, CAPE CORAL, FL. FILED 11-13-2010.

## SNIP 'N' SAVE

THE MARK CONSISTS OF STANDARD CHARACTERS WITHOUT CLAIM TO ANY PARTICULAR FONT, STYLE, SIZE, OR COLOR.

FOR ADVERTISING PAMPHLETS; COUPON BOOKS (U.S. CLS. 2, 5, 22, 23, 29, 37, 38 AND 50).  
FIRST USE 11-11-2010; IN COMMERCE 11-11-2010.  
STEVEN PEREZ, EXAMINING ATTORNEY

SN 85-176,273. A LEVEL ABOVE LEARNING, LLC, WESTMINSTER, CO. FILED 11-14-2010.



THE COLOR(S) GREEN, YELLOW, BLUE, ORANGE, BROWN, BLACK, AND RED IS/ARE CLAIMED AS A FEATURE OF THE MARK.

THE MARK CONSISTS OF GREEN LETTERS SPELLING OUT "FLIP FLOP" SURROUNDED BY A YELLOW OUTLINE. THE WORD "FLIP" IS ON THE TOP AND "FLOP" UNDERNEATH WITH THE "P" IN "FLIP" ATTACHED TO THE "L" IN "FLOP". THE LETTERS IN "FLIP FLOP" ARE REPRESENTED THREE DIMENSIONALLY. THERE IS A FROG ATTACHED TO THE "P" IN "FLIP" AND ANOTHER FROG ATTACHED UPSIDE DOWN TO THE "P" IN "FLOP". THE GREEN FROGS HAVE ORANGE FEET AND HANDS, A BROWN UNDERSIDE, BLUE AND GREEN LEGS, AND RED AND BLACK EYES.

FOR PRINTED INSTRUCTIONAL, EDUCATIONAL, AND TEACHING MATERIALS IN THE FIELD OF MATHEMATICS (U.S. CLS. 2, 5, 22, 23, 29, 37, 38 AND 50).

FIRST USE 0-0-2010; IN COMMERCE 11-1-2010.  
MICHAEL WEBSTER, EXAMINING ATTORNEY

**CLASS 16—(Continued).**

SN 85-176,520. COURAGE UNLIMITED CORPORATION,  
REISTERSTOWN, MD. FILED 11-15-2010.

SPIRIT AND COURAGE MOVES  
MOUNTAINS

THE MARK CONSISTS OF STANDARD CHARACTERS  
WITHOUT CLAIM TO ANY PARTICULAR FONT, STYLE,  
SIZE, OR COLOR.

FOR STORY BOOKS (U.S. CLS. 2, 5, 22, 23, 29, 37, 38  
AND 50).

FIRST USE 2-27-2006; IN COMMERCE 9-7-2006.  
ANDREW LEASER, EXAMINING ATTORNEY

SN 85-176,686. CUDZILO MARTIN F., HOLLAND, MI.  
FILED 11-15-2010.

Rosie the Pig

THE MARK CONSISTS OF STANDARD CHARACTERS  
WITHOUT CLAIM TO ANY PARTICULAR FONT, STYLE,  
SIZE, OR COLOR.

FOR CARTOON PRINTS (U.S. CLS. 2, 5, 22, 23, 29, 37,  
38 AND 50).

BILL DAWE, EXAMINING ATTORNEY

SN 85-176,970. THEOSOPHICAL SOCIETY IN AMERICA,  
WHEATON, IL. FILED 11-15-2010.



THE COLOR(S) BLUE, GRAY, AND WHITE IS/ARE  
CLAIMED AS A FEATURE OF THE MARK.

THE MARK CONSISTS OF BLUE BOX HAVING THE  
LETTER "Q" IN WHITE AND GRAY IN STYLIZED FORM  
DISPOSED WITHIN THE BLUE BOX.

FOR PRINTED MATTER, NAMELY, CATALOGS AND  
BOOKS RELATING TO COMPARATIVE RELIGION,  
PHILOSOPHY, PSYCHOLOGY, METAPHYSICS,  
SCIENCE, AND OCCULTISM (U.S. CLS. 2, 5, 22, 23, 29,  
37, 38 AND 50).

FIRST USE 6-0-2007; IN COMMERCE 6-0-2007.  
KAREN BRACEY, EXAMINING ATTORNEY

**CLASS 16—(Continued).**

SN 85-177,034. THEOSOPHICAL SOCIETY IN AMERICA,  
WHEATON, IL. FILED 11-15-2010.

QUEST

THE MARK CONSISTS OF STANDARD CHARACTERS  
WITHOUT CLAIM TO ANY PARTICULAR FONT, STYLE,  
SIZE, OR COLOR.

FOR PRINTED MATTER, NAMELY, MAGAZINES  
RELATING TO COMPARATIVE RELIGION, PHILOSO-  
PHY, PSYCHOLOGY, METAPHYSICS, SCIENCE, AND  
OCCULTISM (U.S. CLS. 2, 5, 22, 23, 29, 37, 38 AND 50).

FIRST USE 9-0-1988; IN COMMERCE 9-0-1988.  
KAREN BRACEY, EXAMINING ATTORNEY

SN 85-177,878. KIMBERLY-CLARK WORLDWIDE, INC.,  
NEENAH, WI. FILED 11-16-2010.

COOL & LEARN

THE MARK CONSISTS OF STANDARD CHARACTERS  
WITHOUT CLAIM TO ANY PARTICULAR FONT, STYLE,  
SIZE, OR COLOR.

FOR DISPOSABLE TRAINING PANTS (U.S. CLS. 2, 5,  
22, 23, 29, 37, 38 AND 50).

KHANH LE, EXAMINING ATTORNEY

SN 85-177,969. HELEMAR, LLC, AUSTIN, TX. FILED 11-16-  
2010.

HELEMAR

THE MARK CONSISTS OF STANDARD CHARACTERS  
WITHOUT CLAIM TO ANY PARTICULAR FONT, STYLE,  
SIZE, OR COLOR.

FOR CALENDAR DESK PADS; CALENDAR DESK  
STANDS; CALENDAR REFILLS; CALENDARS; CALEN-  
DARS AND DIARIES; GEOGRAPHICAL MAPS; GEO-  
PHYSICAL MAPS; MAPS; POCKET CALENDARS;  
PRINTED CALENDARS; TEAR-OFF CALENDARS;  
WALL CALENDARS (U.S. CLS. 2, 5, 22, 23, 29, 37, 38  
AND 50).

NICHOLAS COLEMAN, EXAMINING ATTORNEY

**CLASS 16—(Continued).**

SN 85-178,053. TRISTAR PRODUCTIONS, INC., HOUSTON, TX. FILED 11-16-2010.

WORLD'S GREATEST CARD CHASE

THE MARK CONSISTS OF STANDARD CHARACTERS WITHOUT CLAIM TO ANY PARTICULAR FONT, STYLE, SIZE, OR COLOR.

FOR SPORTS COLLECTIBLES AND SPORTS MEMORABILIA, NAMELY, SPORTS TRADING CARDS (U.S. CLS. 2, 5, 22, 23, 29, 37, 38 AND 50).

FIRST USE 11-15-2010; IN COMMERCE 11-15-2010.  
LAURIE KAUFMAN, EXAMINING ATTORNEY

---

SN 85-178,215. KINETIX LIVING CORP., SEATTLE, WA. FILED 11-16-2010.



THE MARK CONSISTS OF A STYLIZED DESIGN OF THE CAPITAL LETTER "K" FOLLOWED BY A LOWER CASE "X" ALL WITHIN A SQUARE SHAPED DESIGN.

FOR STATIONERY, WRITING PAPER, ENVELOPES, CALENDARS, BINDERS; STATIONERY-TYPE PORTFOLIOS; JOURNALS FOR RECORDING PERSONAL INFORMATION RELATING TO HEALTHCARE, NUTRITION, WEIGHT LOSS AND WEIGHT CONTROL; PERIODICAL PUBLICATIONS AND BROCHURES, NAMELY, MAGAZINES AND NEWSLETTERS THAT PERTAIN TO HEALTHCARE, NUTRITION, WEIGHT LOSS AND WEIGHT CONTROL; PRINTED TRAINING MANUALS, INSTRUCTIONAL TEACHING MATERIALS AND COOKBOOKS ALL FEATURING RECIPES, INFORMATION AND ADVICE ON HEALTHCARE, NUTRITION, WEIGHT LOSS AND WEIGHT CONTROL (U.S. CLS. 2, 5, 22, 23, 29, 37, 38 AND 50).

GIANCARLO CASTRO, EXAMINING ATTORNEY

**CLASS 16—(Continued).**

SN 85-178,229. KINETIX LIVING CORP., SEATTLE, WA. FILED 11-16-2010.

KX

THE MARK CONSISTS OF STANDARD CHARACTERS WITHOUT CLAIM TO ANY PARTICULAR FONT, STYLE, SIZE, OR COLOR.

FOR STATIONERY, WRITING PAPER, ENVELOPES, CALENDARS, BINDERS; STATIONERY-TYPE PORTFOLIOS; JOURNALS FOR RECORDING PERSONAL INFORMATION RELATING TO HEALTHCARE, NUTRITION, WEIGHT LOSS AND WEIGHT CONTROL; PERIODICAL PUBLICATIONS AND BROCHURES, NAMELY, MAGAZINES AND NEWSLETTERS THAT PERTAIN TO HEALTHCARE, NUTRITION, WEIGHT LOSS AND WEIGHT CONTROL; PRINTED TRAINING MANUALS, INSTRUCTIONAL TEACHING MATERIALS AND COOKBOOKS ALL FEATURING RECIPES, INFORMATION AND ADVICE ON HEALTHCARE, NUTRITION, WEIGHT LOSS AND WEIGHT CONTROL (U.S. CLS. 2, 5, 22, 23, 29, 37, 38 AND 50).

GIANCARLO CASTRO, EXAMINING ATTORNEY

---

SN 85-178,234. KINETIX LIVING CORP., SEATTLE, WA. FILED 11-16-2010.

Rebel. Ignite. Commit.

THE MARK CONSISTS OF STANDARD CHARACTERS WITHOUT CLAIM TO ANY PARTICULAR FONT, STYLE, SIZE, OR COLOR.

FOR STATIONERY, WRITING PAPER, ENVELOPES, CALENDARS, BINDERS; STATIONERY-TYPE PORTFOLIOS; JOURNALS FOR RECORDING PERSONAL INFORMATION RELATING TO HEALTHCARE, NUTRITION, WEIGHT LOSS AND WEIGHT CONTROL; PERIODICAL PUBLICATIONS AND BROCHURES, NAMELY, MAGAZINES AND NEWSLETTERS THAT PERTAIN TO HEALTHCARE, NUTRITION, WEIGHT LOSS AND WEIGHT CONTROL; PRINTED TRAINING MANUALS, INSTRUCTIONAL TEACHING MATERIALS AND COOKBOOKS ALL FEATURING RECIPES, INFORMATION AND ADVICE ON HEALTHCARE, NUTRITION, WEIGHT LOSS AND WEIGHT CONTROL (U.S. CLS. 2, 5, 22, 23, 29, 37, 38 AND 50).

GIANCARLO CASTRO, EXAMINING ATTORNEY



**CLASS 16—(Continued).**

SN 85-178,341. DEMETRICK, LINDA LEE, LOS ANGELES, CA. FILED 11-16-2010.

## Yachtspitality

THE MARK CONSISTS OF STANDARD CHARACTERS WITHOUT CLAIM TO ANY PARTICULAR FONT, STYLE, SIZE, OR COLOR.

FOR GREETINGS CARDS AND POSTCARDS (U.S. CLS. 2, 5, 22, 23, 29, 37, 38 AND 50).  
COLLEEN DOMBROW, EXAMINING ATTORNEY

---

SN 85-178,776. EASTERN CONNECTICUT HEALTH NETWORK, INC., MANCHESTER, CT. FILED 11-17-2010.

## NEIGHBORS & FRIENDS

THE MARK CONSISTS OF STANDARD CHARACTERS WITHOUT CLAIM TO ANY PARTICULAR FONT, STYLE, SIZE, OR COLOR.

FOR PUBLICATIONS, NAMELY, MAGAZINES IN THE FIELDS OF CHARITABLE GIVING, WELLNESS AND HEALTH (U.S. CLS. 2, 5, 22, 23, 29, 37, 38 AND 50).  
FIRST USE 4-1-2000; IN COMMERCE 4-1-2000.  
KATHERINE STOIDES, EXAMINING ATTORNEY

---

SN 85-179,013. BOUND TO ORGANIZE, LLC, GREENVALE, CA. FILED 11-17-2010.

## BOUND TO ORGANIZE

THE MARK CONSISTS OF STANDARD CHARACTERS WITHOUT CLAIM TO ANY PARTICULAR FONT, STYLE, SIZE, OR COLOR.

FOR A SERIES OF BOOKS, WRITTEN ARTICLES, HANDOUTS AND WORKSHEETS IN THE FIELD OF ORGANIZATION (U.S. CLS. 2, 5, 22, 23, 29, 37, 38 AND 50).  
ROBIN CHOSID, EXAMINING ATTORNEY

**CLASS 16—(Continued).**

SN 85-179,531. HAPPY HOUR HANDBOOK, LLC, ST. LOUIS, MO. FILED 11-17-2010.



NO CLAIM IS MADE TO THE EXCLUSIVE RIGHT TO USE "HAPPY HOUR HANDBOOK", APART FROM THE MARK AS SHOWN.

THE MARK CONSISTS OF A STYLIZED CLOCK WITH THE WORDS "HAPPY HOUR" ABOVE THE CLOCK AND THE WORD "HANDBOOK" BELOW THE CLOCK.

FOR BOOKLETS IN THE FIELD OF FOOD, DRINK, AND ENTERTAINMENT (U.S. CLS. 2, 5, 22, 23, 29, 37, 38 AND 50).

FIRST USE 11-15-2010; IN COMMERCE 11-15-2010.  
LAKEISHA LEWIS, EXAMINING ATTORNEY

---

SN 85-180,126. HAWKINS, CRAIG H., NORTH CALDWELL, NJ. FILED 11-18-2010.

## Filenzi

THE MARK CONSISTS OF THE WORD "FILENZI" SET IN THE SANS-SERIF FONT CALLED CALIBRI.

FOR SHEET MUSIC (U.S. CLS. 2, 5, 22, 23, 29, 37, 38 AND 50).

FIRST USE 10-25-2010; IN COMMERCE 11-17-2010.  
ROBERT STRUCK, EXAMINING ATTORNEY

---

SN 85-180,289. MARIE'S WORDS, INC., CARLSBAD, CA. FILED 11-18-2010.

## PROCURE THE CURE

THE MARK CONSISTS OF STANDARD CHARACTERS WITHOUT CLAIM TO ANY PARTICULAR FONT, STYLE, SIZE, OR COLOR.

FOR FLASH CARDS (U.S. CLS. 2, 5, 22, 23, 29, 37, 38 AND 50).

PAUL E. FAHRENKOPF, EXAMINING ATTORNEY

**CLASS 16—(Continued).**

SN 85-181,544. I C PROTECTION, INC., JUPITER, FL. FILED 11-19-2010.

sure & secure with  

**ICpro**

THE MARK CONSISTS OF THE STYLIZED TEXT "SURE & SECURE WITH I C PRO" WITH THE LETTER "C" SHAPED LIKE THREE QUARTERS OF AN EYE BALL WITH A PUPIL IN THE MIDDLE AND THREE EYE LASHES ABOVE.

FOR TEMPORARY TATTOOS, NAMELY, INDICIA WITH IDENTIFICATION INFORMATION FOR THE PURPOSE OF LOCATING LOST INDIVIDUALS (U.S. CLS. 2, 5, 22, 23, 29, 37, 38 AND 50).

FIRST USE 7-17-2009; IN COMMERCE 10-1-2009.  
 ALLISON SCHRODY, EXAMINING ATTORNEY

SN 85-183,126. SALT LIFE HOLDINGS, LLC, JACKSONVILLE, FL. FILED 11-23-2010.

WHERE THE SALT MEETS YOUR  
 LIFE

THE MARK CONSISTS OF STANDARD CHARACTERS WITHOUT CLAIM TO ANY PARTICULAR FONT, STYLE, SIZE, OR COLOR.

FOR CALENDARS; COASTERS OF PAPER; COIN HOLDERS; DECALS; MAGAZINES IN THE FIELD OF SPORTS AND OUTDOOR LIFE; MONEY CLIPS; PAPER BANNERS; PAPER NAPKINS; PAPER TABLE CLOTHS; PHOTOGRAPHIC ALBUMS; POSTERS; STATIONERY; STICKERS (U.S. CLS. 2, 5, 22, 23, 29, 37, 38 AND 50).

APRIL HESIK, EXAMINING ATTORNEY

SN 85-183,282. GEORGIA-PACIFIC CONSUMER PRODUCTS LP, ATLANTA, GA. FILED 11-23-2010.

**INNERLUX**

THE MARK CONSISTS OF STANDARD CHARACTERS WITHOUT CLAIM TO ANY PARTICULAR FONT, STYLE, SIZE, OR COLOR.

FOR BATHROOM TISSUE (U.S. CLS. 2, 5, 22, 23, 29, 37, 38 AND 50).

MICHAEL WIENER, EXAMINING ATTORNEY

**CLASS 16—(Continued).**

SN 85-186,059. MARDEL, INC., OKLAHOMA CITY, OK. FILED 11-29-2010.

**FAITHFOLIO**

THE MARK CONSISTS OF STANDARD CHARACTERS WITHOUT CLAIM TO ANY PARTICULAR FONT, STYLE, SIZE, OR COLOR.

FOR BLANK JOURNALS (U.S. CLS. 2, 5, 22, 23, 29, 37, 38 AND 50).

SEAN CROWLEY, EXAMINING ATTORNEY

SN 85-186,184. MARDEL, INC., OKLAHOMA CITY, OK. FILED 11-29-2010.

**ELOQUENTIALS**

THE MARK CONSISTS OF STANDARD CHARACTERS WITHOUT CLAIM TO ANY PARTICULAR FONT, STYLE, SIZE, OR COLOR.

FOR NOTE CARDS; NOTEPADS (U.S. CLS. 2, 5, 22, 23, 29, 37, 38 AND 50).

SEAN CROWLEY, EXAMINING ATTORNEY

SN 85-186,248. MARDEL, INC., OKLAHOMA CITY, OK. FILED 11-29-2010.

**GALAGRACE**

THE MARK CONSISTS OF STANDARD CHARACTERS WITHOUT CLAIM TO ANY PARTICULAR FONT, STYLE, SIZE, OR COLOR.

FOR NOTE CARDS; NOTEPADS (U.S. CLS. 2, 5, 22, 23, 29, 37, 38 AND 50).

SEAN CROWLEY, EXAMINING ATTORNEY

**CLASS 16—(Continued).**

SN 85-194,099. DOW JONES & COMPANY, INC., NEW YORK, NY. FILED 12-9-2010.

**WSJ**

THE MARK CONSISTS OF STANDARD CHARACTERS WITHOUT CLAIM TO ANY PARTICULAR FONT, STYLE, SIZE, OR COLOR.  
OWNER OF U.S. REG. NOS. 2,119,170, 2,575,504 AND OTHERS.  
FOR NEWSPAPERS (U.S. CLS. 2, 5, 22, 23, 29, 37, 38 AND 50).  
FIRST USE 9-25-2010; IN COMMERCE 9-25-2010.  
MARK SHINER, EXAMINING ATTORNEY

SN 85-194,809. GEORGIA-PACIFIC CONSUMER PRODUCTS LP, ATLANTA, GA. FILED 12-10-2010.

**THE STRENGTH TO TAKE ON  
TOUGH MESSAGES**

THE MARK CONSISTS OF STANDARD CHARACTERS WITHOUT CLAIM TO ANY PARTICULAR FONT, STYLE, SIZE, OR COLOR.  
FOR PAPER TOWELS (U.S. CLS. 2, 5, 22, 23, 29, 37, 38 AND 50).  
MICHAEL WIENER, EXAMINING ATTORNEY

SN 85-196,495. GEORGIA-PACIFIC CONSUMER PRODUCTS LP, ATLANTA, GA. FILED 12-13-2010.

**THE CLEAN FEELING YOU  
EXPECT, THE GENTLENESS YOU  
WANT**

THE MARK CONSISTS OF STANDARD CHARACTERS WITHOUT CLAIM TO ANY PARTICULAR FONT, STYLE, SIZE, OR COLOR.  
FOR BATHROOM TISSUE (U.S. CLS. 2, 5, 22, 23, 29, 37, 38 AND 50).  
MICHAEL WIENER, EXAMINING ATTORNEY

**CLASS 16—(Continued).**

SN 85-197,618. HOBBY LOBBY STORES, INC., OKLAHOMA CITY, OK. FILED 12-14-2010.

**SHOW-OFFS**

THE MARK CONSISTS OF STANDARD CHARACTERS WITHOUT CLAIM TO ANY PARTICULAR FONT, STYLE, SIZE, OR COLOR.  
FOR PAINT APPLICATOR ROLLERS; STENCILS (U.S. CLS. 2, 5, 22, 23, 29, 37, 38 AND 50).  
FIRST USE 6-26-2010; IN COMMERCE 7-19-2010.  
DEIRDRE ROBERTSON, EXAMINING ATTORNEY

SN 85-201,096. YAFA PEN COMPANY, INC., CANOGA PARK, CA. FILED 12-17-2010.

**ONE TOUCH**

THE MARK CONSISTS OF STANDARD CHARACTERS WITHOUT CLAIM TO ANY PARTICULAR FONT, STYLE, SIZE, OR COLOR.  
FOR PENS (U.S. CLS. 2, 5, 22, 23, 29, 37, 38 AND 50).  
MORGAN WYNNE, EXAMINING ATTORNEY

SN 85-202,136. THOMAS JR, KENNETH RAY, NORTH LAS VEGAS, NV. FILED 12-20-2010.

**OSO SEXY**

THE MARK CONSISTS OF STANDARD CHARACTERS WITHOUT CLAIM TO ANY PARTICULAR FONT, STYLE, SIZE, OR COLOR.  
FOR MAGAZINES FEATURING FEATURING WOMEN MODELING LINGERIE AND SWIM SUITS (U.S. CLS. 2, 5, 22, 23, 29, 37, 38 AND 50).  
COLLEEN KEARNEY, EXAMINING ATTORNEY

**CLASS 16—(Continued).**

SN 85-202,751. BONNIER ACTIVE MEDIA, INC., WINTER PARK, FL. FILED 12-21-2010.

# Freeze

THE MARK CONSISTS OF STANDARD CHARACTERS WITHOUT CLAIM TO ANY PARTICULAR FONT, STYLE, SIZE, OR COLOR.  
FOR GENERAL FEATURE MAGAZINES (U.S. CLS. 2, 5, 22, 23, 29, 37, 38 AND 50).  
ELLEN BURNS, EXAMINING ATTORNEY

**CLASS 16—(Continued).**

SN 85-228,345. JOHN GENNARO, CRANFORD, NJ. FILED 1-27-2011.

# WAD

THE MARK CONSISTS OF STANDARD CHARACTERS WITHOUT CLAIM TO ANY PARTICULAR FONT, STYLE, SIZE, OR COLOR.  
FOR MONEY CLIPS (U.S. CLS. 2, 5, 22, 23, 29, 37, 38 AND 50).  
DORITT L. CARROLL, EXAMINING ATTORNEY

SN 85-208,663. EMERALD MUSE, INC., ULSTER PARK, NY. FILED 12-31-2010.

# PUNDORA'S PUN'KIN PATCH

THE MARK CONSISTS OF STANDARD CHARACTERS WITHOUT CLAIM TO ANY PARTICULAR FONT, STYLE, SIZE, OR COLOR.  
FOR GREETING CARDS; POST CARDS (U.S. CLS. 2, 5, 22, 23, 29, 37, 38 AND 50).  
FIRST USE 9-20-2010; IN COMMERCE 12-15-2010.  
MELISSA VALLILLO, EXAMINING ATTORNEY

SN 85-228,346. JOHN GENNARO, CRANFORD, NJ. FILED 1-27-2011.

# MOB WAD

THE MARK CONSISTS OF STANDARD CHARACTERS WITHOUT CLAIM TO ANY PARTICULAR FONT, STYLE, SIZE, OR COLOR.  
FOR MONEY CLIPS (U.S. CLS. 2, 5, 22, 23, 29, 37, 38 AND 50).  
DORITT L. CARROLL, EXAMINING ATTORNEY

SN 85-211,199. LIVE NATION WORLDWIDE, INC., BEVERLY HILLS, CA. FILED 1-5-2011.

# ARTIST NATION

THE MARK CONSISTS OF STANDARD CHARACTERS WITHOUT CLAIM TO ANY PARTICULAR FONT, STYLE, SIZE, OR COLOR.  
FOR PRINTED MATTER, NAMELY, CALENDARS, POSTCARDS, POSTERS, STICKERS, DECALS, NOTE CARDS AND NOTEPADS (U.S. CLS. 2, 5, 22, 23, 29, 37, 38 AND 50).  
RAUL CORDOVA, EXAMINING ATTORNEY

SN 85-233,832. UNITED STATES OLYMPIC COMMITTEE, COLORADO SPRINGS, CO. FILED 2-3-2011.

# ONCE AN OLYMPIAN ALWAYS AN OLYMPIAN, NEVER FORMER NEVER PAST

THE MARK CONSISTS OF STANDARD CHARACTERS WITHOUT CLAIM TO ANY PARTICULAR FONT, STYLE, SIZE, OR COLOR.  
OWNER OF U.S. REG. NOS. 1,734,781 AND 2,755,806.  
FOR NEWSLETTERS AND MAGAZINES CONCERNING THE ACTIVITIES OF THE U.S. OLYMPIC COMMITTEE AND ATHLETES WHO HAVE COMPETED FOR THE UNITED STATES IN INTERNATIONAL SPORTS COMPETITION (U.S. CLS. 2, 5, 22, 23, 29, 37, 38 AND 50).  
FIRST USE 12-31-1997; IN COMMERCE 12-31-1997.  
JEFFERY COWARD, EXAMINING ATTORNEY

**CLASS 17—RUBBER GOODS**

SN 77-855,812. PIEDMONT PLASTICS, INC., CHARLOTTE, NC. FILED 10-23-2009.

**Natural Solutions**

THE MARK CONSISTS OF STANDARD CHARACTERS WITHOUT CLAIM TO ANY PARTICULAR FONT, STYLE, SIZE, OR COLOR.

NO CLAIM IS MADE TO THE EXCLUSIVE RIGHT TO USE "NATURAL", APART FROM THE MARK AS SHOWN.

FOR PLASTICS IN THE FORM OF SHEETS, FILMS, BLOCKS, RODS AND TUBES (U.S. CLS. 1, 5, 12, 13, 35 AND 50).

ALLISON SCHRODY, EXAMINING ATTORNEY

SN 77-946,196. LAYFIELD POLY FILMS LTD., RICHMOND, CANADA, FILED 2-26-2010.

**FREEZERFLEX**

THE MARK CONSISTS OF STANDARD CHARACTERS WITHOUT CLAIM TO ANY PARTICULAR FONT, STYLE, SIZE, OR COLOR.

PRIORITY CLAIMED UNDER SEC. 44(D) ON CANADA APPLICATION NO. 1450247, FILED 9-1-2009, REG. NO. TMA775039, DATED 8-19-2010, EXPIRES 8-19-2025.

FOR HIGH STRENGTH PLASTIC FILMS USED AS PACKAGING FOR FROZEN FOOD FOR COMMERCIAL USE (U.S. CLS. 1, 5, 12, 13, 35 AND 50).

ALYSSA STEEL, EXAMINING ATTORNEY

SN 85-133,950. BECKER-UNDERWOOD, INC., AMES, IA. FILED 9-20-2010.

**CUSHIONFALL SPORT**

THE MARK CONSISTS OF STANDARD CHARACTERS WITHOUT CLAIM TO ANY PARTICULAR FONT, STYLE, SIZE, OR COLOR.

OWNER OF U.S. REG. NO. 3,554,004.

NO CLAIM IS MADE TO THE EXCLUSIVE RIGHT TO USE "SPORT", APART FROM THE MARK AS SHOWN.

FOR COATED RUBBER CRUMBS USED AS INFILL FOR ARTIFICIAL TURF (U.S. CLS. 1, 5, 12, 13, 35 AND 50).

FIRST USE 7-0-2009; IN COMMERCE 7-0-2009.

JERI J. FICKES, EXAMINING ATTORNEY

**CLASS 17—(Continued).**

SN 85-140,912. CLEAR FOCUS IMAGING, INC., SANTA ROSA, CA. FILED 9-29-2010.

**DO-ALLINER**

THE MARK CONSISTS OF STANDARD CHARACTERS WITHOUT CLAIM TO ANY PARTICULAR FONT, STYLE, SIZE, OR COLOR.

FOR POLYESTER PLASTIC RELEASE LINERS USED IN CONNECTION WITH PRINTED PAPER AND PLASTIC FILMS WHICH ARE USED IN ADVERTISING, PROMOTION, SIGNAGE, SHADING, DISPLAYING TEXT AND GRAPHICS, AND ONE-WAY VIEWING FROM HOMES AND BUILDINGS (U.S. CLS. 1, 5, 12, 13, 35 AND 50).

FIRST USE 9-23-2010; IN COMMERCE 9-23-2010.

JEFFREY LOOK, EXAMINING ATTORNEY

SN 85-155,258. BERGER, RUSSELL E. II, ADDISON, TX. FILED 10-18-2010.

**Double Green**

THE MARK CONSISTS OF STANDARD CHARACTERS WITHOUT CLAIM TO ANY PARTICULAR FONT, STYLE, SIZE, OR COLOR.

NO CLAIM IS MADE TO THE EXCLUSIVE RIGHT TO USE "GREEN", APART FROM THE MARK AS SHOWN.

FOR ACOUSTIC AND THERMAL INSULATION FOR USE IN THE AUTOMOTIVE, HVAC, APPLIANCE AND COMMERCIAL INTERIOR INDUSTRIES; ACOUSTICAL INSULATION FOR BUILDINGS; ACOUSTICAL PANELS FOR BUILDINGS (U.S. CLS. 1, 5, 12, 13, 35 AND 50).

PATRICIA EVANKO, EXAMINING ATTORNEY

SN 85-173,550. PRINTEX PACKAGING CORPORATION, ISLANDIA, NY. FILED 11-10-2010.

**PLANTEX**

THE MARK CONSISTS OF STANDARD CHARACTERS WITHOUT CLAIM TO ANY PARTICULAR FONT, STYLE, SIZE, OR COLOR.

FOR PLASTIC FILMS USED AS PACKAGING FOR WHOLESALE AND RETAIL ITEMS (U.S. CLS. 1, 5, 12, 13, 35 AND 50).

DAVID TAYLOR, EXAMINING ATTORNEY

**CLASS 17—(Continued).**

SN 85-177,744. RHH FOAM SYSTEMS, INC., NEW BERLIN, WI. FILED 11-16-2010.

**VERSI-BLOCK**

THE MARK CONSISTS OF STANDARD CHARACTERS WITHOUT CLAIM TO ANY PARTICULAR FONT, STYLE, SIZE, OR COLOR.

FOR FOAM INSULATION FOR USE IN BUILDING AND CONSTRUCTION (U.S. CLS. 1, 5, 12, 13, 35 AND 50).

MELISSA VALLILLO, EXAMINING ATTORNEY

SN 85-177,749. RHH FOAM SYSTEMS, INC., NEW BERLIN, WI. FILED 11-16-2010.

**VERSI-STOP**

THE MARK CONSISTS OF STANDARD CHARACTERS WITHOUT CLAIM TO ANY PARTICULAR FONT, STYLE, SIZE, OR COLOR.

FOR FOAM INSULATION FOR USE IN BUILDING AND CONSTRUCTION (U.S. CLS. 1, 5, 12, 13, 35 AND 50).

MELISSA VALLILLO, EXAMINING ATTORNEY

SN 85-178,045. INSULATION SOLUTIONS, INC., EAST PEORIA, IL. FILED 11-16-2010.

**INSULLITE**

THE MARK CONSISTS OF STANDARD CHARACTERS WITHOUT CLAIM TO ANY PARTICULAR FONT, STYLE, SIZE, OR COLOR.

OWNER OF U.S. REG. NO. 3,331,306.  
FOR INSULATION BARRIERS OF METAL AND FIBERGLASS (U.S. CLS. 1, 5, 12, 13, 35 AND 50).

FIRST USE 10-13-2006; IN COMMERCE 3-17-2010.

ANDREA HACK, EXAMINING ATTORNEY

**CLASS 17—(Continued).**

SN 85-178,782. LOGAN, GERALD A., HILLSBORO, OR. AND LOGAN, SEAN S., PORTLAND, OR. FILED 11-17-2010.

**UVC**

THE MARK CONSISTS OF STANDARD CHARACTERS WITHOUT CLAIM TO ANY PARTICULAR FONT, STYLE, SIZE, OR COLOR.

FOR CLEAR SHEETS OF POLYMERIC FILM FOR SURFACE PROTECTION OF PAINTED SURFACES (U.S. CLS. 1, 5, 12, 13, 35 AND 50).

ALEXANDER L. POWERS, EXAMINING ATTORNEY

SN 85-179,067. LOGAN, GERALD A., HILLSBORO, OR. AND LOGAN, SEAN S., PORTLAND, OR. FILED 11-17-2010.



THE MARK CONSISTS OF "UVCLEAR" IS WRITTEN UNDER A SUN (CIRCLE WITH FIVE RAYS EMANATING FROM THE CIRCLE). BOTH THE SUN AND THE LETTERING "UVCLEAR" ARE CONTAINED WITHIN THREE RECTANGULAR FRAMES.

FOR CLEAR SHEETS OF POLYMERIC FILM FOR THE SURFACE PROTECTION OF PAINTED SURFACES (U.S. CLS. 1, 5, 12, 13, 35 AND 50).

ALEXANDER L. POWERS, EXAMINING ATTORNEY

SN 85-181,160. GRAVITY GROUP, INC., WEST ALLIS, WI. FILED 11-19-2010.

**Flat Tire**

THE MARK CONSISTS OF STANDARD CHARACTERS WITHOUT CLAIM TO ANY PARTICULAR FONT, STYLE, SIZE, OR COLOR.

OWNER OF U.S. REG. NOS. 3,088,749 AND 3,581,812.  
FOR PADDING MATERIALS OF RUBBER OR PLASTIC; RUBBER FOR USE IN THE MANUFACTURE OF SOLES OF SHOES, PADDING OF SHOE SOLES, CUSHIONING AND OTHER ITEMS FEATURING RUBBER AND CRUMB RUBBER FROM RECYCLED TIRES (U.S. CLS. 1, 5, 12, 13, 35 AND 50).

FIRST USE 12-10-2005; IN COMMERCE 1-13-2006.

SUE LAWRENCE, EXAMINING ATTORNEY

**CLASS 18—LEATHER GOODS**

SN 77-148,639. MY SPORT ROCKS, INC., TORONTO, ONTARIO, CANADA, FILED 4-4-2007.

**MY SPORT ROCKS**

THE MARK CONSISTS OF STANDARD CHARACTERS WITHOUT CLAIM TO ANY PARTICULAR FONT, STYLE, SIZE, OR COLOR.

FOR SPORT BAGS, NAMELY, TOTE BAGS, ALL-PURPOSE ATHLETIC BAGS, ALL-PURPOSE SPORT BAGS, BACKPACKS, PROMOTIONAL MATERIAL, NAMELY, LEATHER KEY CHAINS AND UMBRELLAS; COSMETIC CASES SOLD EMPTY (U.S. CLS. 1, 2, 3, 22 AND 41).

CHARLOTTE CORWIN, EXAMINING ATTORNEY

SN 77-885,170. JUDI CARTER, MIAMI, FL. FILED 12-3-2009.

**JUDI CARTER**

THE MARK CONSISTS OF STANDARD CHARACTERS WITHOUT CLAIM TO ANY PARTICULAR FONT, STYLE, SIZE, OR COLOR.

THE NAME(S), PORTRAIT(S), AND/OR SIGNATURE(S) SHOWN IN THE MARK DOES NOT IDENTIFY A PARTICULAR LIVING INDIVIDUAL.

FOR HANDBAGS; SATCHELS; WALLETS (U.S. CLS. 1, 2, 3, 22 AND 41).

ESTHER BELENKER, EXAMINING ATTORNEY

SN 85-010,485. UNIVERSAL TATTOO, LLC, LOS ANGELES, CA. FILED 4-9-2010.

**ROCKHAUS**

THE MARK CONSISTS OF STANDARD CHARACTERS WITHOUT CLAIM TO ANY PARTICULAR FONT, STYLE, SIZE, OR COLOR.

FOR LUGGAGE, TRUNKS, SUITCASES, BRIEFCASES, BAGS, NAMELY, BACKPACKS, SHOULDER BAGS, TOTE BAGS, CARRY-ON BAGS, CLUTCH BAGS, DUFFEL BAGS, GARMENT BAGS FOR TRAVEL, HANDBAGS, ATTACHE CASES, WALLETS, PURSES (U.S. CLS. 1, 2, 3, 22 AND 41).

TRACY CROSS, EXAMINING ATTORNEY

**CLASS 18—(Continued).**

SN 85-122,452. BEST TRADE ENVIRONMENTAL UMBRELLA (HK) CO., LTD, KWUN TONG, KOWLOON, HONG KONG, FILED 9-3-2010.



PRIORITY CLAIMED UNDER SEC. 44(D) ON HONG KONG APPLICATION NO. 301701963, FILED 8-30-2010, REG. NO. 301701963, DATED 8-30-2010, EXPIRES 8-30-2020.

THE COLOR(S) GREEN, WHITE AND GRAY IS/ARE CLAIMED AS A FEATURE OF THE MARK.

THE MARK CONSISTS OF THE WHITE WORD "DANDELION", WITH THE VERTICAL PART OF THE SECOND "D" CONNECTED TO A WHITE STALK AND WHITE HEAD OF A DANDELION, ALL INSIDE A GREEN CIRCLE; A GRAY SHADOW OF THE CIRCLE APPEARS AT THE LEFT SIDE OF THE DRAWING.

FOR FRAMES FOR UMBRELLAS; COVERS FOR UMBRELLAS; UMBRELLAS; BAGS FOR UMBRELLAS; BEACH UMBRELLAS; TELESCOPIC UMBRELLAS; PARASOLS (U.S. CLS. 1, 2, 3, 22 AND 41).

AMEEN IMAM, EXAMINING ATTORNEY

SN 85-155,370. ONE OF A KIND EVENTS, LLC, ATLANTA, GA. FILED 10-18-2010.

**LAINA + MERR**

THE MARK CONSISTS OF STANDARD CHARACTERS WITHOUT CLAIM TO ANY PARTICULAR FONT, STYLE, SIZE, OR COLOR.

THE NAME "LAINA MERR" DOES NOT IDENTIFY A LIVING INDIVIDUAL.

FOR DIAPER BAGS; HANDBAGS (U.S. CLS. 1, 2, 3, 22 AND 41).

THOMAS MANOR, EXAMINING ATTORNEY

**CLASS 18—(Continued).**

SN 85-156,072. CHATEAU INTERNATIONAL INC., NEW YORK, NY. FILED 10-19-2010.



OWNER OF U.S. REG. NOS. 634,499, 3,712,131 AND 3,862,171.

THE MARK CONSISTS OF GAZELLE IN A CIRCLE. FOR LADIES PURSES, POCKETBOOKS AND HANDBAGS; BACKPACKS, ALL PURPOSE SPORTS BAGS, MESSENGER BAGS, TOILETRY BAGS SOLD EMPTY; SMALL LEATHER ACCESSORIES, NAMELY WALLETS, KEY CHAINS AND KEY CASES; UMBRELLAS (U.S. CLS. 1, 2, 3, 22 AND 41).

BRENDAN MCCAULEY, EXAMINING ATTORNEY

**CLASS 18—(Continued).**

SN 85-158,576. MICHELLE ELLEN CLINTON, SAN FRANCISCO, CA. FILED 10-21-2010.

**BELLA BEAN**

THE MARK CONSISTS OF STANDARD CHARACTERS WITHOUT CLAIM TO ANY PARTICULAR FONT, STYLE, SIZE, OR COLOR.

THE NAME "BELLA BEAN" DOES NOT IDENTIFY A LIVING INDIVIDUAL. FOR DOG COLLARS AND LEADS (U.S. CLS. 1, 2, 3, 22 AND 41).

FIRST USE 11-20-2003; IN COMMERCE 11-20-2003. WILLIAM VERHOSEK, EXAMINING ATTORNEY

SN 85-172,266. MARCY MCKENNA, NEWPORT BEACH, CA. FILED 11-9-2010.



THE NAME "MARCY MCKENNA" IDENTIFIES A LIVING INDIVIDUAL WHOSE CONSENT IS OF RECORD.

FOR LEATHER GOODS, NAMELY, HANDBAGS AND PURSES (U.S. CLS. 1, 2, 3, 22 AND 41).

SIMON TENG, EXAMINING ATTORNEY

SN 85-156,167. CHATEAU INTERNATIONAL INC., NEW YORK, NY. FILED 10-19-2010.



OWNER OF U.S. REG. NOS. 634,499, 3,712,131 AND 3,862,171.

THE MARK CONSISTS OF A GAZELLE. FOR LADIES PURSES, POCKETBOOKS AND HANDBAGS; BACKPACKS, ALL PURPOSE SPORTS BAGS, MESSENGER BAGS, TOILETRY BAGS SOLD EMPTY; SMALL LEATHER ACCESSORIES, NAMELY WALLETS, KEY CHAINS AND KEY CASES; UMBRELLAS (U.S. CLS. 1, 2, 3, 22 AND 41).

BRENDAN MCCAULEY, EXAMINING ATTORNEY

SN 85-176,558. FRAWLEY, SANDRA, GREENWOOD LAKE, NY. FILED 11-15-2010.

**BABYBINDLE**

THE MARK CONSISTS OF STANDARD CHARACTERS WITHOUT CLAIM TO ANY PARTICULAR FONT, STYLE, SIZE, OR COLOR.

FOR MULTI-PURPOSE PURSES AND BAGS FOR CARRYING BABIES' ACCESSORIES (U.S. CLS. 1, 2, 3, 22 AND 41).

TASNEEM HUSSAIN, EXAMINING ATTORNEY



**CLASS 18—(Continued).**

SN 85-176,580. FRAWLEY, SANDRA, GREENWOOD LAKE, NY. FILED 11-15-2010.

# SEATPAK

THE MARK CONSISTS OF STANDARD CHARACTERS WITHOUT CLAIM TO ANY PARTICULAR FONT, STYLE, SIZE, OR COLOR.

FOR BAGS FOR CARRYING BABIES' ACCESSORIES (U.S. CLS. 1, 2, 3, 22 AND 41).

TASNEEM HUSSAIN, EXAMINING ATTORNEY

SN 85-177,747. WIESNER PRODUCTS INC., NEW YORK, NY. FILED 11-16-2010.

# STREET KLUB

THE MARK CONSISTS OF STANDARD CHARACTERS WITHOUT CLAIM TO ANY PARTICULAR FONT, STYLE, SIZE, OR COLOR.

FOR BACKPACKS (U.S. CLS. 1, 2, 3, 22 AND 41).

TOBY BULLOFF, EXAMINING ATTORNEY

SN 85-179,270. DANA MARKS, NEW BRAUNFELS, TX. FILED 11-17-2010.

# itty bitty brella

THE MARK CONSISTS OF STANDARD CHARACTERS WITHOUT CLAIM TO ANY PARTICULAR FONT, STYLE, SIZE, OR COLOR.

FOR UMBRELLAS (U.S. CLS. 1, 2, 3, 22 AND 41).

KARANENDRA S. CHHINA, EXAMINING ATTORNEY

SN 85-180,018. JANSPOUT APPAREL CORP., WILMINGTON, DE. FILED 11-18-2010.

# UNHINGED

THE MARK CONSISTS OF STANDARD CHARACTERS WITHOUT CLAIM TO ANY PARTICULAR FONT, STYLE, SIZE, OR COLOR.

FOR BACKPACKS (U.S. CLS. 1, 2, 3, 22 AND 41).

FIRST USE 5-12-2010; IN COMMERCE 5-12-2010.

KEVIN DINALLO, EXAMINING ATTORNEY

**CLASS 18—(Continued).**

SN 85-180,435. ORAK, JACOB, PASADENA, CA. FILED 11-18-2010.

# ETHNOTEK

THE MARK CONSISTS OF STANDARD CHARACTERS WITHOUT CLAIM TO ANY PARTICULAR FONT, STYLE, SIZE, OR COLOR.

FOR BACKPACKS; SHOULDER BAGS (U.S. CLS. 1, 2, 3, 22 AND 41).

JAY FLOWERS, EXAMINING ATTORNEY

SN 85-180,441. MLA MULTIBRAND HOLDINGS, INC., VERNON, CA. FILED 11-18-2010.

# TWELVE TWO

THE MARK CONSISTS OF STANDARD CHARACTERS WITHOUT CLAIM TO ANY PARTICULAR FONT, STYLE, SIZE, OR COLOR.

FOR HANDBAGS, PURSES, CLUTCHES, COSMETIC BAGS SOLD EMPTY, SHOULDER BAGS, BRIEF CASES, ATTACHÉ CASES, OVERNIGHT BAGS, COSMETIC CASES SOLD EMPTY, SATCHELS, BACK PACKS, LEATHER KEY CHAINS, VANITY CASES SOLD EMPTY, LUGGAGE AND UMBRELLAS (U.S. CLS. 1, 2, 3, 22 AND 41).

LAURA KOVALSKY, EXAMINING ATTORNEY

SN 85-180,520. MLA MULTIBRAND HOLDINGS, INC., VERNON, CA. FILED 11-18-2010.

# 12-2

THE MARK CONSISTS OF STANDARD CHARACTERS WITHOUT CLAIM TO ANY PARTICULAR FONT, STYLE, SIZE, OR COLOR.

FOR HANDBAGS, PURSES, CLUTCHES, COSMETIC BAGS SOLD EMPTY, SHOULDER BAGS, BRIEF CASES, ATTACHÉ CASES, OVERNIGHT BAGS, COSMETIC CASES SOLD EMPTY, SATCHELS, BACK PACKS, LEATHER KEY CHAINS, VANITY CASES SOLD EMPTY, LUGGAGE AND UMBRELLAS (U.S. CLS. 1, 2, 3, 22 AND 41).

IRA J. GOODSАID, EXAMINING ATTORNEY

**CLASS 18—(Continued).**

SN 85-181,448. PRANA LIVING, LLC, VISTA, CA. FILED 11-19-2010.



THE MARK CONSISTS OF A STYLIZED DRAWING OF A PERSON SITTING IN A YOGA POSE.

FOR INDOOR AND OUTDOOR CLIMBING ACCESSORIES, NAMELY, CHALK BAGS, BACKPACKS, AND TOTE BAGS; FELT AND WOOL POUCHES AND SATCHELS (U.S. CLS. 1, 2, 3, 22 AND 41).

LINDA MICKLEBURGH, EXAMINING ATTORNEY

SN 85-186,912. JANSPOURT APPAREL CORP., WILMINGTON, DE. FILED 11-30-2010.



OWNER OF U.S. REG. NO. 2,226,566.  
THE MARK CONSISTS OF A STYLIZED PARTIAL GLOBE DESIGN.

FOR ATTACHE CASES; BACKPACKS; BAGS FOR CLIMBERS IN THE NATURE OF ALL-PURPOSE CARRYING BAGS; BOOK BAGS; BRIEFCASES; CARRY-ON BAGS; CLUTCH BAGS; COSMETIC CARRYING CASES SOLD EMPTY; DAYPACKS; DUFFEL BAGS; FANNY PACKS; GARMENT BAGS FOR TRAVEL; HANDBAGS; KEYCASES; KNAPSACKS; LUGGAGE; MESSENGER BAGS; POCKET WALLETS; PURSES; RUCKSACKS; SCHOOL BAGS; SHOULDER BAGS; SPORTS BAGS; SUITCASES; TOILETRY BAGS SOLD EMPTY; TOTE BAGS; TRAVEL BAGS; TRAVEL CASES; VANITY CASES SOLD EMPTY; WAIST PACKS; WALLETS; WHEELED BAGS (U.S. CLS. 1, 2, 3, 22 AND 41).

KEVIN DINALLO, EXAMINING ATTORNEY

**CLASS 18—(Continued).**

SN 85-211,208. LIVE NATION WORLDWIDE, INC., BEVERLY HILLS, CA. FILED 1-5-2011.

**ARTIST NATION**

THE MARK CONSISTS OF STANDARD CHARACTERS WITHOUT CLAIM TO ANY PARTICULAR FONT, STYLE, SIZE, OR COLOR.

FOR BAGS, NAMELY, TOTE BAGS, ALL-PURPOSE CARRYING BAGS, BACKPACKS, DUFFEL BAGS (U.S. CLS. 1, 2, 3, 22 AND 41).

RAUL CORDOVA, EXAMINING ATTORNEY

SN 85-245,711. PANAMA JACK INTERNATIONAL, INC., ORLANDO, FL. FILED 2-18-2011.

**PANAMA JACK OUTFITTERS**

THE MARK CONSISTS OF STANDARD CHARACTERS WITHOUT CLAIM TO ANY PARTICULAR FONT, STYLE, SIZE, OR COLOR.

OWNER OF U.S. REG. NOS. 1,328,519, 2,942,960 AND OTHERS.

NO CLAIM IS MADE TO THE EXCLUSIVE RIGHT TO USE "OUTFITTERS", APART FROM THE MARK AS SHOWN.

THE NAME(S), PORTRAIT(S), AND/OR SIGNATURE(S) SHOWN IN THE MARK DOES NOT IDENTIFY A PARTICULAR LIVING INDIVIDUAL.

FOR BACKPACKS, DUFFEL BAGS, ALL PURPOSE GEAR BAGS, FANNY PACKS, TRAVEL BAGS, TOTE BAGS, BEACH BAGS, WALLETS, HANDBAGS, LUGGAGE TAGS, TRUNKS, LEATHER KEY CHAINS, UMBRELLAS, ROLL BAGS, ALL-PURPOSE SPORT BAGS, COSMETIC BAGS SOLD EMPTY, LUGGAGE, ATHLETIC BAGS, CLUTCH BAGS, BILLFOLDS, BOOK BAGS, CHANGE PURSES; OVERNIGHT BAGS; POCKET-BOOKS; PURSES; SCHOOL BAGS; WALKING STICKS; ATTACHE CASES, BRIEFCASE-TYPE PORTFOLIOS; BUSINESS CARD CASES; CANES; FOOTLOCKERS AND SUITCASES (U.S. CLS. 1, 2, 3, 22 AND 41).

AMY KERTGATE, EXAMINING ATTORNEY

**CLASS 19—NON-METALLIC BUILDING MATERIALS**

SN 76-703,115. PRACTICAL ENVIRONMENTAL SOLUTIONS, DBA HYDROLOGIC SOLUTIONS, WOODBRIDGE, VA. FILED 5-25-2010.



THE COLOR(S) ORANGE, BLUE, DARK BLUE, GRAY, DARK GRAY AND BLACK IS/ARE CLAIMED AS A FEATURE OF THE MARK.

THE MARK CONSISTS OF THE WORDING "STORM-CHAMBER" BELOW A DESIGN RESEMBLING A PARTIALLY EXPOSED SUN, AN INCOMPLETE CIRCLE, A RISING SUN, OR AN ARCH EXTENDING FROM A HORIZONTAL LINE. THE WORD "STORM" IS IN BLUE WITH DARKER BLUE OUTLINING AND "CHAMBER" IS IN GRAY WITH DARKER GRAY OUTLINING. THE SUN, INCOMPLETE CIRCLE, RISING SUN OR ARCH DESIGN AND THE HORIZONTAL LINE ARE IN ORANGE HAVING BLACK OUTLINING.

FOR STORM WATER MANAGEMENT DEVICES, NAMELY, NON METAL CATCHMENT BASINS AND NON-METAL DETENTION BASINS IN THE NATURE OF CISTERNS (U.S. CLS. 1, 12, 33 AND 50).

FIRST USE 10-0-2009; IN COMMERCE 10-0-2009.  
DOMINIC FATHY, EXAMINING ATTORNEY

**CLASS 19—(Continued).**

SN 77-847,854. NORBORD INDUSTRIES INC., TORONTO, ONTARIO, CANADA, FILED 10-13-2009.

**PINNACLE**

THE MARK CONSISTS OF STANDARD CHARACTERS WITHOUT CLAIM TO ANY PARTICULAR FONT, STYLE, SIZE, OR COLOR.

PRIORITY CLAIMED UNDER SEC. 44(D) ON CANADA APPLICATION NO. 1,434,494, FILED 4-14-2009, REG. NO. TMA781,019, DATED 10-28-2010, EXPIRES 10-28-2025.

FOR STRUCTURAL WOOD FLOOR PANELS, NAMELY, ORIENTED STRAND BOARD (U.S. CLS. 1, 12, 33 AND 50).

FIRST USE 6-1-2009; IN COMMERCE 6-1-2009.  
NELSON SNYDER, EXAMINING ATTORNEY

SN 77-965,821. LIBERTY DIVERSIFIED INDUSTRIES, INC., MINNEAPOLIS, MN. FILED 3-23-2010.

SN 77-839,558. MAXXON CORPORATION, HAMEL, MN. FILED 10-1-2009.

**ACOUSTI-MAT LP**

THE MARK CONSISTS OF STANDARD CHARACTERS WITHOUT CLAIM TO ANY PARTICULAR FONT, STYLE, SIZE, OR COLOR.

OWNER OF U.S. REG. NO. 1,690,840.

NO CLAIM IS MADE TO THE EXCLUSIVE RIGHT TO USE "LP", APART FROM THE MARK AS SHOWN.

FOR FLEXIBLE FLOOR UNDERLAYMENT PADS (U.S. CLS. 1, 12, 33 AND 50).

FIRST USE 10-7-2008; IN COMMERCE 10-7-2008.  
TRICIA SONNEBORN, EXAMINING ATTORNEY

**TRIMLINE MULTI ROLL**

THE MARK CONSISTS OF STANDARD CHARACTERS WITHOUT CLAIM TO ANY PARTICULAR FONT, STYLE, SIZE, OR COLOR.

OWNER OF U.S. REG. NOS. 1,838,625 AND 1,876,503.

NO CLAIM IS MADE TO THE EXCLUSIVE RIGHT TO USE "ROLL", APART FROM THE MARK AS SHOWN.

FOR ROOF VENTILATION SYSTEM, NAMELY, NON-METAL SOFFIT AND ROOF RIDGE VENTS (U.S. CLS. 1, 12, 33 AND 50).

FIRST USE 2-0-2010; IN COMMERCE 2-0-2010.  
FONG HSU, EXAMINING ATTORNEY

**CLASS 19—(Continued).**

SN 85-001,683. WEBSTER PIERCE, JR., CUT OFF, LA. FILED 3-30-2010.

**WAVE ROBBER**

THE MARK CONSISTS OF STANDARD CHARACTERS WITHOUT CLAIM TO ANY PARTICULAR FONT, STYLE, SIZE, OR COLOR.

NO CLAIM IS MADE TO THE EXCLUSIVE RIGHT TO USE "WAVE", APART FROM THE MARK AS SHOWN.

FOR A SYSTEM COMPRISING A PLURALITY OF RIGID PVC TYPE MATERIAL PIPES POSITIONED WITHIN A RIGID FRAME TO SUPPRESS WAVE ACTION AND PROVIDE LAND RESTORATION ALONG THE SHORE OF A BODY OF WATER, SUCH AS A COASTLINE, HAVING A PLURALITY OF INTERCONNECTED SECTIONS OF FLUID FLOW PIPES FOR ALLOWING WATER INCLUDING SEDIMENT TO FLOW INTO THE PIPES AT THE FORWARD WALL AND EXIT THE PIPES AT THE REAR WALL, IN ORDER TO COLLECT THE SEDIMENT ALONG THE REAR WALL OF THE PIPES (U.S. CLS. 1, 12, 33 AND 50).

BARBARA BROWN, EXAMINING ATTORNEY

**CLASS 19—(Continued).**

SN 85-074,241. DISTRIBUTION D'ALUMINIUM JANSO INC., LE GARDEUR QC, CANADA, FILED 6-29-2010.



NO CLAIM IS MADE TO THE EXCLUSIVE RIGHT TO USE "LES REVÊTEMENTS" AND "ST-LAURENT" AND "SIDING", APART FROM THE MARK AS SHOWN.

THE MARK CONSISTS OF THE WORDS "LES REVÊTEMENTS" STACKED ABOVE THE WORDING "ST-LAURENT" WHICH IS ABOVE THE WORD "SIDING". THE WORDING "ST-LAURENT" IS OUTLINED IN AN OBLONG OVAL SHAPE AND THE WORDING "LES REVÊTEMENTS" AND "SIDING" IS OUTLINED IN AN OVAL SHAPE. A RECTANGULAR WOOD DESIGN IS IN THE FAR BACKGROUND.

THE ENGLISH TRANSLATION OF "LES REVÊTEMENTS" IN THE MARK IS "THE SIDINGS".

FOR NON-METAL BUILDING PRODUCTS, NAMELY, SHUTTERS, SHINGLES, SIDING, AND TRIM; WOOD SIDING (U.S. CLS. 1, 12, 33 AND 50).

FIRST USE 5-1-2010; IN COMMERCE 5-1-2010.

JANICE KIM, EXAMINING ATTORNEY

SN 85-119,192. RONBOW MATERIALS CORPORATION, NEWARK, CA. FILED 8-30-2010.

**WIDEAPPEAL**

THE MARK CONSISTS OF STANDARD CHARACTERS WITHOUT CLAIM TO ANY PARTICULAR FONT, STYLE, SIZE, OR COLOR.

FOR BUILDING MATERIALS, NAMELY, NON-METAL COUNTERTOPS OF ENGINEERED STONE FOR FURTHER INSTALLATION (U.S. CLS. 1, 12, 33 AND 50).

MARY CRAWFORD, EXAMINING ATTORNEY

SN 85-024,463. ATLAS ROOFING CORPORATION, MERIDIAN, MS. FILED 4-27-2010.

**SlabMax**

THE MARK CONSISTS OF STANDARD CHARACTERS WITHOUT CLAIM TO ANY PARTICULAR FONT, STYLE, SIZE, OR COLOR.

FOR EXPANDED POLYSTYRENE (EPS) FOR USE AS VOID FILL IN BUILDING AND CONSTRUCTION INCLUDING STADIUM SEATING, RETAINING WALLS, FOUNDATION STABILIZATION, FLOOR LEVELING, SWIMMING POOLS, LOADING DOCKS AND RAMPS (U.S. CLS. 1, 12, 33 AND 50).

ZACHARY BELLO, EXAMINING ATTORNEY

SN 85-125,363. ASPHALT SYSTEMS, INC., SALT LAKE CITY, UT. FILED 9-8-2010.

**GSB-88**

THE MARK CONSISTS OF STANDARD CHARACTERS WITHOUT CLAIM TO ANY PARTICULAR FONT, STYLE, SIZE, OR COLOR.

FOR ASPHALT-BASED SEALANTS FOR USE ON PAVEMENTS (U.S. CLS. 1, 12, 33 AND 50).

FIRST USE 12-31-1990; IN COMMERCE 12-31-1990.

CHRISTINE COOPER, EXAMINING ATTORNEY

**CLASS 19—(Continued).**

SN 85-125,366. ASPHALT SYSTEMS, INC., SALT LAKE CITY, UT. FILED 9-8-2010.

# GSB-78

THE MARK CONSISTS OF STANDARD CHARACTERS WITHOUT CLAIM TO ANY PARTICULAR FONT, STYLE, SIZE, OR COLOR.

FOR ASPHALT-BASED SEALANTS FOR USE ON PAVEMENTS (U.S. CLS. 1, 12, 33 AND 50).

FIRST USE 12-31-1970; IN COMMERCE 12-31-1970.  
CHRISTINE COOPER, EXAMINING ATTORNEY

**CLASS 19—(Continued).**

SN 85-144,920. ASIA TECHNOLOGIES 21 PTE LTD, SINGAPORE, SINGAPORE, FILED 10-5-2010.

# REVWOOD

THE MARK CONSISTS OF STANDARD CHARACTERS WITHOUT CLAIM TO ANY PARTICULAR FONT, STYLE, SIZE, OR COLOR.

FOR NON-METALLIC COMPOSITE MATERIALS, NAMELY, FIBREBOARD AND STRUCTURAL SECTIONS COMPOSED OF FIBROUS MATERIALS AND PLASTIC FOR USE IN CONSTRUCTING, FENCES, DECKS AND DOCKS (U.S. CLS. 1, 12, 33 AND 50).

EDWARD NELSON, EXAMINING ATTORNEY

SN 85-131,817. PELLA CORPORATION, PELLA, IA. FILED 9-17-2010.

# DURACAST

THE MARK CONSISTS OF STANDARD CHARACTERS WITHOUT CLAIM TO ANY PARTICULAR FONT, STYLE, SIZE, OR COLOR.

OWNER OF U.S. REG. NO. 2,887,227.

FOR COMPONENT PARTS OF NON-METAL DOORS AND WINDOWS SOLD AS AN INTEGRAL PART THEREOF, NAMELY, NON-METAL DOOR AND WINDOW FRAMES, PANELS, AND SILLS WITH HEADS AND JAMBS (U.S. CLS. 1, 12, 33 AND 50).

FIRST USE 1-31-2003; IN COMMERCE 1-31-2003.  
ANGELA DUONG, EXAMINING ATTORNEY

SN 85-149,027. SEIDLER, CARL W., WINTERSSET, IA. FILED 10-9-2010.

# CornBoard

SN 85-136,609. KLEER LUMBER, INC., WESTFIELD, MA. FILED 9-23-2010.

# TRUEDGE

THE MARK CONSISTS OF THE WORD "TRUEDGE". THE TOP BAR OF THE CAPITAL LETTER "T" IS ELONGATED TO THE RIGHT AND SITS OVER THE LOWER CASE "R" AND THE "U". THE REST OF THE WORD "EDGE" IS IN ALL CAPITAL LETTERS.

FOR LUMBER MADE OUT OF MANMADE MATERIAL (U.S. CLS. 1, 12, 33 AND 50).

MATTHEW MCDOWELL, EXAMINING ATTORNEY

THE MARK CONSISTS OF STANDARD CHARACTERS WITHOUT CLAIM TO ANY PARTICULAR FONT, STYLE, SIZE, OR COLOR.

FOR COMPOSITE BUILDING MATERIALS, NAMELY, STRUCTURAL COMPOSITE BOARDS AND PANELS MADE FROM FIBROUS HUSK AND STALK WASTE PRODUCTS OF CORN PROCESSING (U.S. CLS. 1, 12, 33 AND 50).

RUSS HERMAN, EXAMINING ATTORNEY

**CLASS 19—(Continued).**

SN 85-154,683. EUREKA WOODWORKS, INC., DALLAS, TX.  
FILED 10-18-2010.



NO CLAIM IS MADE TO THE EXCLUSIVE RIGHT TO USE "HOUSES", APART FROM THE MARK AS SHOWN.

THE COLOR(S) RED AND DARK BROWN IS/ARE CLAIMED AS A FEATURE OF THE MARK.

THE MARK CONSISTS OF A RED DOG OUTLINED IN DARK BROWN IN FRONT OF A SKETCH OF A BROWN DOGHOUSE PLACED ABOVE THE WORDS "RED DAWG", WRITTEN IN RED STYLIZED FONT AND OUTLINED IN DARK BROWN, AND THE WORD "HOUSES" WRITTEN IN DARK BROWN.

FOR MODULAR DOG HOUSES; PRE-FABRICATED DOG HOUSES (U.S. CLS. 1, 12, 33 AND 50).  
JUSTINE D. PARKER, EXAMINING ATTORNEY

SN 85-155,113. STUDIO5051, LLC, DBA STUDIO5051, MINNEAPOLIS, MN. FILED 10-18-2010.

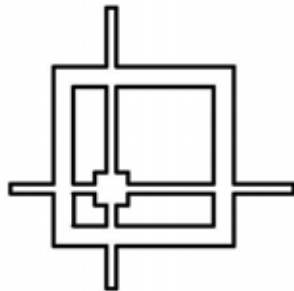

THE MARK CONSISTS OF A DESIGN CONTAINING TWO INTERCONNECTED, DIFFERENTLY SIZED SQUARES, ONE HOUSED WITHIN THE OTHER, WHEREIN A SMALL SQUARE IS FRAMED BY A LARGER SQUARE AND IS LOCATED IN THE LOWER LEFT CORNER OF THE LARGER SQUARE, AND WHEREIN FURTHER THE LARGE SQUARE HAS A BORDER CONSISTING OF TWO THIN PARALLEL LINES THAT FORM A FRAME, AND THE PERIMETER OF THE SMALL SQUARE CONSISTS OF A SINGLE LINE THAT IS BROKEN ON EACH SIDE OF ITS FOUR SIDES AND FROM WHERE A PAIR OF PARALLEL LINES EMANATES FROM EACH OF THE SMALLER SQUARE'S FOUR SIDES AT 90 DEGREE ANGLES, THOSE PARALLEL LINES EXTENDING AND INTERSECTING THE PERIMETER OF THE LARGER SQUARE AT 90 DEGREE ANGLES.

FOR CONCRETE BUILDING MATERIALS, NAMELY, PAVERS, WALL BLOCKS (U.S. CLS. 1, 12, 33 AND 50).  
RONALD DELGIZZI, EXAMINING ATTORNEY

**CLASS 19—(Continued).**

SN 85-167,040. C&C NORTH AMERICA, INC., STAFFORD, TX. FILED 11-2-2010.

## Q-Line Quartz

THE MARK CONSISTS OF STANDARD CHARACTERS WITHOUT CLAIM TO ANY PARTICULAR FONT, STYLE, SIZE, OR COLOR.

NO CLAIM IS MADE TO THE EXCLUSIVE RIGHT TO USE "QUARTZ", APART FROM THE MARK AS SHOWN.

FOR NONSTRUCTURAL BUILDING MATERIALS FOR KITCHENS AND BATHROOMS OF ENGINEERED STONE MADE IN SIGNIFICANT PART OF QUARTZ, NAMELY, COUNTERTOPS AND BACKSPLASHES (U.S. CLS. 1, 12, 33 AND 50).

KELLY CHOE, EXAMINING ATTORNEY

SN 85-167,047. C&C NORTH AMERICA, INC., STAFFORD, TX. FILED 11-2-2010.

## Q-LINE QUARTZ BY COSENTINO

THE MARK CONSISTS OF STANDARD CHARACTERS WITHOUT CLAIM TO ANY PARTICULAR FONT, STYLE, SIZE, OR COLOR.

NO CLAIM IS MADE TO THE EXCLUSIVE RIGHT TO USE "QUARTZ", APART FROM THE MARK AS SHOWN.

FOR NONSTRUCTURAL BUILDING MATERIALS FOR KITCHENS AND BATHROOMS OF ENGINEERED STONE MADE IN SIGNIFICANT PART OF QUARTZ, NAMELY, COUNTERTOPS AND BACKSPLASHES (U.S. CLS. 1, 12, 33 AND 50).

KELLY CHOE, EXAMINING ATTORNEY

SN 85-173,352. VARIFORM, INC., KANSAS CITY, MO. FILED 11-10-2010.

## TRIPLE BOW

THE MARK CONSISTS OF STANDARD CHARACTERS WITHOUT CLAIM TO ANY PARTICULAR FONT, STYLE, SIZE, OR COLOR.

FOR FEATURE OF VINYL SIDING PANELS BY WHICH AN OVERSIZED CHANNEL AND RETURN LEG IS LOCKED IN PLACE UPON INSTALLATION, SOLD AS A COMPONENT OF THE PANELS (U.S. CLS. 1, 12, 33 AND 50).

RONALD AIKENS, EXAMINING ATTORNEY

**CLASS 19—(Continued).**

SN 85-173,355. VARIFORM, INC., KANSAS CITY, MO.  
FILED 11-10-2010.

**VORTEX EXTREME**

THE MARK CONSISTS OF STANDARD CHARACTERS WITHOUT CLAIM TO ANY PARTICULAR FONT, STYLE, SIZE, OR COLOR.

FOR VINYL SIDING PANELS FOR EXTERIOR SURFACES OF RESIDENTIAL AND COMMERCIAL BUILDINGS, AND MOBILE HOMES (U.S. CLS. 1, 12, 33 AND 50).

RONALD AIKENS, EXAMINING ATTORNEY

SN 85-173,362. VARIFORM, INC., KANSAS CITY, MO.  
FILED 11-10-2010.

**WEATHER WARRIOR**

THE MARK CONSISTS OF STANDARD CHARACTERS WITHOUT CLAIM TO ANY PARTICULAR FONT, STYLE, SIZE, OR COLOR.

FOR COLOR HOLD ENHANCER SOLD AS A CONSTITUENT OF VINYL SIDING AND VINYL SIDING ACCESSORIES, NAMELY, INSIDE CORNER POSTS, J CHANNEL, UNDERSILL TRIM, AND OUTSIDE CORNER POSTS (U.S. CLS. 1, 12, 33 AND 50).

RONALD AIKENS, EXAMINING ATTORNEY

SN 85-174,618. RUBBER-CAL, INC., SANTA ANA, CA. FILED  
11-11-2010.

**ECO-SAFETY**

THE MARK CONSISTS OF STANDARD CHARACTERS WITHOUT CLAIM TO ANY PARTICULAR FONT, STYLE, SIZE, OR COLOR.

FOR RUBBER AND SYNTHETIC NON-METAL TILES FOR USE ON INDOOR AND OUTDOOR FLOORS, RUBBER FLOORING, RUBBER FLOOR TILES (U.S. CLS. 1, 12, 33 AND 50).

FIRST USE 3-1-2010; IN COMMERCE 3-1-2010.  
ELLEN BURNS, EXAMINING ATTORNEY

**CLASS 19—(Continued).**

SN 85-180,230. PORTABLE COMPOSITE STRUCTURES, INC., IRVINE, CA. FILED 11-18-2010.

**ZIPFLAT**

THE MARK CONSISTS OF STANDARD CHARACTERS WITHOUT CLAIM TO ANY PARTICULAR FONT, STYLE, SIZE, OR COLOR.

FOR PORTABLE NON-METAL SHELTER STRUCTURES; NAMELY FOLDABLE BUILDING STRUCTURE EMPLOYING FOAM-CORE BUILDING PANELS (U.S. CLS. 1, 12, 33 AND 50).

WILLIAM P. SHANAHAN, EXAMINING ATTORNEY

**CLASS 20—FURNITURE AND ARTICLES NOT OTHERWISE CLASSIFIED**

SN 77-733,465. COMMERCIAL PLASTICS COMPANY/OC DESIGNS, MUNDELEIN, IL. FILED 5-11-2009.



THE MARK CONSISTS OF TWO LETTER "C"'S CONNECTED.

FOR DINING CHAIRS; OFFICE CHAIRS (U.S. CLS. 2, 13, 22, 25, 32 AND 50).

FONG HSU, EXAMINING ATTORNEY

SN 77-962,387. PLASTECH INNOVATIONS, LLC, MIAMI, FL.  
FILED 3-18-2010.

**BODDLE**

THE MARK CONSISTS OF STANDARD CHARACTERS WITHOUT CLAIM TO ANY PARTICULAR FONT, STYLE, SIZE, OR COLOR.

FOR PLASTIC FILMS USED AS PACKAGING FOR FOOD, NAMELY, PLASTIC PACKAGING FOR BEVERAGES AND DRINKING WATER (U.S. CLS. 2, 13, 22, 25, 32 AND 50).

ROBIN MITTLER, EXAMINING ATTORNEY

**CLASS 20—(Continued).**

SN 79-083,054. BALTO, FRANCE, FILED 4-29-2010.

**ORION**

PRIORITY DATE OF 4-22-2010 IS CLAIMED.  
OWNER OF INTERNATIONAL REGISTRATION 1040081  
DATED 4-29-2010, EXPIRES 4-29-2020.

FOR PICTURE FRAMES; NON-METALLIC BARRELS,  
NON-METALLIC CASKS; DRUMS AND VATS OF  
WOOD, CORKS FOR BOTTLES, CORKS, NON-METAL  
BOTTLE CAPS, BOTTLE RACKS, BOTTLE CLOSURES  
OF WOOD, NON-METALLIC BOTTLE STOPPERS, DIS-  
PLAY CASES OF WOOD OR PLASTIC, NON-METALLIC  
TAPS FOR CASKS, WINE RACKS, STORAGE RACKS  
FOR BOTTLES, CASKS AND BARRELS, BARREL  
HOOPS NOT OF METAL, CASK HOOPS NOT OF  
METAL, CASK STANDS NOT OF METAL, BOTTLE  
CASINGS OF WOOD (U.S. CLS. 2, 13, 22, 25, 32 AND 50).  
ALICE BENMAMAN, EXAMINING ATTORNEY

**CLASS 20—(Continued).**

SN 85-002,375. LISA MCCARTHY, SAN DIEGO, CA. FILED 3-30-2010.

**MEYEVU**

THE MARK CONSISTS OF STANDARD CHARACTERS  
WITHOUT CLAIM TO ANY PARTICULAR FONT, STYLE,  
SIZE, OR COLOR.

FOR MIRRORS (U.S. CLS. 2, 13, 22, 25, 32 AND 50).  
AMY C. KEAN, EXAMINING ATTORNEY

SN 79-083,150. ANJI WEIYU FURNITURE CO., LTD.,  
CHINA, FILED 3-29-2010.

WEIYU  
伟誉家具

OWNER OF INTERNATIONAL REGISTRATION 1040359  
DATED 3-29-2010, EXPIRES 3-29-2020.

NO CLAIM IS MADE TO THE EXCLUSIVE RIGHT TO  
USE THE NON-LATIN CHARACTERS THAT TRANSLITE-  
RATE TO JIAJU, APART FROM THE MARK AS SHOWN.

THE MARK CONSISTS OF THE STYLIZED TERM  
"WEIYU" WITH SHADED AREAS IN THE "W", "Y" AND  
"U" AND A SHADED CIRCLE ABOVE THE "I". THERE IS A  
DARK HORIZONTAL LINE UNDERNEATH THE TERM  
"WEIYU", AND FOUR CHINESE CHARACTERS BELOW  
THE LINE WHICH TRANSLITERATE TO WEI YU JIA JU,  
RESPECTIVELY FROM LEFT TO RIGHT.

THE NON-LATIN CHARACTERS IN THE MARK TRANS-  
LITERATE TO WEI YU JIA JU AND THIS MEANS BIG  
REPUTATION FURNITURE IN ENGLISH.

FOR BENCHES, OFFICE FURNITURE, CHAIRS,  
SEATS, EASY CHAIRS, TABLES, SOFAS, DECK  
CHAIRS, DESKS, BAMBOO CURTAINS, CRAFTS MADE  
OF BAMBOO AND WOOD, NAMELY, FIGURINES,  
STATUES, STATUETTES, SCULPTURES, PLAQUES,  
CARVINGS, BOXES (U.S. CLS. 2, 13, 22, 25, 32 AND 50).  
JENNIFER DIXON, EXAMINING ATTORNEY

SN 85-004,673. PEGATRON CORPORATION, TAIPEI CITY  
112, TAIWAN, FILED 4-1-2010.

PRIORITY CLAIMED UNDER SEC. 44(D) ON TAIWAN  
APPLICATION NO. 099012260, FILED 3-19-2010, REG. NO.  
01434949, DATED 10-16-2010, EXPIRES 10-15-2020.

THE MARK CONSISTS OF A STYLIZED LETTER "P"  
WITHIN A CIRCLE.

FOR STANDING BOOKCASES; MOVING-AISLE FIL-  
ING AND STORAGE SHELVING; SHELVES FOR  
BOOKS; BOOKCASES, NAMELY, BOOK HOLDERS;  
CHAIR CUSHIONS (U.S. CLS. 2, 13, 22, 25, 32 AND 50).  
TINA MAI, EXAMINING ATTORNEY



**CLASS 20—(Continued).**

SN 85-031,512. BO-REGARDS, INC., ROCKLEDGE, FL. FILED 5-6-2010.



THE MARK CONSISTS OF A DRAWING OF A DOG WITH THE MARK "BO REGARDS.COM" IN STYLIZED FORM UNDERNEATH THE DOG.

FOR INDOOR AND OUTDOOR PLAQUES, MADE OF PLASTIC, FRAMES FOR PICTURES ALL RELATED TO MESSAGES REGARDING PETS (U.S. CLS. 2, 13, 22, 25, 32 AND 50).

ANN E. SAPPENFIELD, EXAMINING ATTORNEY

**CLASS 20—(Continued).**

SN 85-052,116. MALLIK MARGOT B, TA BABY REST, ATLANTA, GA. FILED 6-1-2010.



NO CLAIM IS MADE TO THE EXCLUSIVE RIGHT TO USE "BABY", APART FROM THE MARK AS SHOWN.

THE COLOR(S) BLACK, WHITE AND BLUE IS/ARE CLAIMED AS A FEATURE OF THE MARK.

THE MARK CONSISTS OF A BLACK OUTSIDE BORDER AND A THIN WHITE INNER BORDER. THE IMAGE BACKGROUND IS BLUE. THE LITERAL ELEMENT "BABY REST" IS WRITTEN IN BLACK WITH AN OUTLINED, CUSTOM IMAGE OF A MOTHER IN BLACK AND CHILD IN WHITE IN BETWEEN THE TWO WORDS "BABY REST".

FOR BABY HEAD SUPPORT CUSHIONS (U.S. CLS. 2, 13, 22, 25, 32 AND 50).

NAAKWAMA ANKRAH, EXAMINING ATTORNEY

SN 85-036,804. CHECKPOINT SYSTEMS, INC., THOROFARE, NJ. FILED 5-12-2010.

# KEEPERS

THE MARK CONSISTS OF STANDARD CHARACTERS WITHOUT CLAIM TO ANY PARTICULAR FONT, STYLE, SIZE, OR COLOR.

FOR LOCKABLE STORAGE CONTAINERS, BOTH WITH AND WITHOUT ELECTRONIC ARTICLE SURVEILLANCE TAGS, TO PREVENT THEFT AT RETAIL STORES MADE PRIMARILY OF PLASTIC; DISPLAY CASES FOR MERCHANDISE (U.S. CLS. 2, 13, 22, 25, 32 AND 50).

MATTHEW KLINE, EXAMINING ATTORNEY

SN 85-075,050. ROCKLER COMPANIES, INC., MEDINA, MN. FILED 6-30-2010.

# PACK RACK

THE MARK CONSISTS OF STANDARD CHARACTERS WITHOUT CLAIM TO ANY PARTICULAR FONT, STYLE, SIZE, OR COLOR.

NO CLAIM IS MADE TO THE EXCLUSIVE RIGHT TO USE "RACK", APART FROM THE MARK AS SHOWN.

FOR FREE STANDING STORAGE SYSTEM ON WHEELS FOR HANGING AND STORING TOOLS (U.S. CLS. 2, 13, 22, 25, 32 AND 50).

FIRST USE 5-0-2008; IN COMMERCE 5-0-2008.

INGA ERVIN, EXAMINING ATTORNEY

**CLASS 20—(Continued).**

SN 85-078,815. HANDI QUILTER, INC., NORTH SALT LAKE, UT. FILED 7-6-2010.



OWNER OF U.S. REG. NOS. 2,920,821, 3,559,066 AND OTHERS.

NO CLAIM IS MADE TO THE EXCLUSIVE RIGHT TO USE "HANDY QUILTER", APART FROM THE MARK AS SHOWN.

THE MARK CONSISTS OF A STYLIZED IMAGE OF A NEEDLE AND THREAD TO THE LEFT OF THE WORDS "HANDI QUILTER", WITH THE THREAD CONTINUING BELOW THE WORDS AS A DASHED LINE.

FOR ADJUSTABLE HEIGHT AND LENGTH TABLES AND COMBINED TABLE AND FRAME UNITS THAT HAVE ADJUSTABLE HEIGHT AND LENGTH (U.S. CLS. 2, 13, 22, 25, 32 AND 50).

FIRST USE 1-31-2006; IN COMMERCE 1-31-2006.  
RONALD AIKENS, EXAMINING ATTORNEY

SN 85-086,848. DOVEN, EUGENE R., CORPUS CHRISTI, TX. FILED 7-16-2010.

## Fun Meter

THE MARK CONSISTS OF STANDARD CHARACTERS WITHOUT CLAIM TO ANY PARTICULAR FONT, STYLE, SIZE, OR COLOR.

SEC. 2(F).  
FOR NOVELTY BUTTONS (U.S. CLS. 2, 13, 22, 25, 32 AND 50).

FIRST USE 12-19-1986; IN COMMERCE 12-19-1986.  
INGRID C. EULIN, EXAMINING ATTORNEY

SN 85-095,016. MICHAEL ROTHBARD, CARPINTERIA, CA. FILED 7-28-2010.

## Rethink Sleep

THE MARK CONSISTS OF STANDARD CHARACTERS WITHOUT CLAIM TO ANY PARTICULAR FONT, STYLE, SIZE, OR COLOR.

NO CLAIM IS MADE TO THE EXCLUSIVE RIGHT TO USE "SLEEP", APART FROM THE MARK AS SHOWN.

FOR BED PILLOWS; MATTRESS TOPPERS; MATTRESSES; MATTRESSES AND PILLOWS (U.S. CLS. 2, 13, 22, 25, 32 AND 50).

FIRST USE 7-15-2010; IN COMMERCE 7-15-2010.  
KRISTIN DAHLING, EXAMINING ATTORNEY

**CLASS 20—(Continued).**

SN 85-104,843. WU, YAO-CHUAN, CHIAYI HSIEN, 621, TAIWAN, FILED 8-11-2010.



THE MARK CONSISTS OF A CHINESE CHARACTER FOLLOWED BY THE LETTER "I" IN UPPERCASE AND THE LETTERS "OO" IN LOWERCASE.

THE NON-LATIN CHARACTERS IN THE MARK TRANSLITERATE TO "IOO" AND THIS MEANS GOOD IN ENGLISH.

FOR BEDS; CABINETS; CHAIR CUSHIONS; CHAIR PADS; CHAIRS; FURNITURE PARTS, NAMELY, ARM RESTS, CHAIR LEGS; HIGH CHAIRS FOR BABIES; OFFICE CHAIRS; OFFICE SEATS; PORTABLE BACK SUPPORT FOR USE WITH CHAIRS; RECLINING CHAIRS; RESIDENTIAL AND COMMERCIAL WROUGHT IRON FURNITURE; SOFAS; TABLES (U.S. CLS. 2, 13, 22, 25, 32 AND 50).

WARREN L. OLANDRIA, EXAMINING ATTORNEY

SN 85-119,654. AMERICAN SEATING COMPANY, GRAND RAPIDS, MI. FILED 8-31-2010.

## BIO CHAIR

THE MARK CONSISTS OF STANDARD CHARACTERS WITHOUT CLAIM TO ANY PARTICULAR FONT, STYLE, SIZE, OR COLOR.

OWNER OF U.S. REG. NO. 1,583,680.  
NO CLAIM IS MADE TO THE EXCLUSIVE RIGHT TO USE "CHAIR", APART FROM THE MARK AS SHOWN.

FOR OFFICE FURNITURE, NAMELY, CHAIRS (U.S. CLS. 2, 13, 22, 25, 32 AND 50).

GINA HAYES, EXAMINING ATTORNEY

**CLASS 20—(Continued).**

SN 85-123,082. ZINUS INC., HAYWARD, CA. FILED 9-3-2010.



THE COLOR(S) WHITE, BLACK AND PINK IS/ARE CLAIMED AS A FEATURE OF THE MARK.

THE MARK CONSISTS OF THE WORD "VIVON" ABOVE THE WORD "VERVE". THE LETTERS "V", "I", "O" AND "N" IN "VIVON" ARE IN BLACK. THE LETTER "V" IN THIS WORD IS IN PINK AS IS THE DOT FOR THE LETTER "I". ABOVE THE RIGHT WING OF THE "V" IN "VIVON" IS A CURVED BLACK LINE. ALL OF THIS SITS ON A WHITE BACKGROUND. THE WORD "VERVE" IS IN WHITE BLOCK LETTERS, THE LETTERS OF "VERVE" ARE ALSO OUTLINED IN BLACK.

FOR MATTRESS FOUNDATIONS; MATTRESS TOPPERS; MATTRESSES AND PILLOWS (U.S. CLS. 2, 13, 22, 25, 32 AND 50).

FIRST USE 8-1-2010; IN COMMERCE 8-1-2010.  
DOMINICK J. SALEMI, EXAMINING ATTORNEY

SN 85-123,912. MICHAEL ROTHBARD, CARPINTERIA, CA.  
FILED 9-7-2010.

## Powered by Sleep

THE MARK CONSISTS OF STANDARD CHARACTERS WITHOUT CLAIM TO ANY PARTICULAR FONT, STYLE, SIZE, OR COLOR.

FOR BEDS, MATTRESSES, PILLOWS AND BOLSTERS; MATTRESS TOPPERS (U.S. CLS. 2, 13, 22, 25, 32 AND 50).

FIRST USE 9-1-2010; IN COMMERCE 9-1-2010.  
MICHAEL KEATING, EXAMINING ATTORNEY

SN 85-124,097. HERMAN MILLER, INC., ZEELAND, MI.  
FILED 9-7-2010.

## ARCSPAN

THE MARK CONSISTS OF STANDARD CHARACTERS WITHOUT CLAIM TO ANY PARTICULAR FONT, STYLE, SIZE, OR COLOR.

FOR OFFICE FURNITURE, NAMELY, A COMPONENT USED IN OFFICE CHAIRS, NAMELY, THE SEAT BASE (U.S. CLS. 2, 13, 22, 25, 32 AND 50).

FLORENTINA BLANDU, EXAMINING ATTORNEY

**CLASS 20—(Continued).**

SN 85-131,870. SAFE TV SHOP, LLC, CHARLOTTE, NC. FILED 9-17-2010.

## SHAPE-A-DRAPE

THE MARK CONSISTS OF STANDARD CHARACTERS WITHOUT CLAIM TO ANY PARTICULAR FONT, STYLE, SIZE, OR COLOR.

FOR DRAPERY HARDWARE, NAMELY, A PRE-MOLDED FORM FOR MAINTAINING DRAPERIES IN A DESIRED CONFIGURATION (U.S. CLS. 2, 13, 22, 25, 32 AND 50).

DEBRA LEE, EXAMINING ATTORNEY

SN 85-139,222. WINDOW WORLD INTERNATIONAL, LLC,  
NORTH WILKESBORO, NC. FILED 9-27-2010.

## WINDOW WORLD

THE MARK CONSISTS OF STANDARD CHARACTERS WITHOUT CLAIM TO ANY PARTICULAR FONT, STYLE, SIZE, OR COLOR.

OWNER OF U.S. REG. NOS. 2,331,991, 3,016,669 AND 3,244,991.

NO CLAIM IS MADE TO THE EXCLUSIVE RIGHT TO USE "WINDOW", APART FROM THE MARK AS SHOWN.

FOR WINDOW BLINDS; WINDOW SHADES (U.S. CLS. 2, 13, 22, 25, 32 AND 50).

ALLISON HOLTZ, EXAMINING ATTORNEY

SN 85-140,011. FCI HOLDINGS DELAWARE, INC., WILMINGTON, DE. FILED 9-28-2010.

## PYTHON

THE MARK CONSISTS OF THE WORD "PYTHON" WITH A SNAKE EYE IN THE "O".

FOR METAL MINE ROOF BOLTS (U.S. CLS. 2, 13, 22, 25, 32 AND 50).

FIRST USE 9-20-2010; IN COMMERCE 9-23-2010.  
GINA HAYES, EXAMINING ATTORNEY

**CLASS 20—(Continued).**

SN 85-145,960. CHAU, WAI K., ELMWOOD PARK, NJ. FILED 10-6-2010.

**MUNI DISPLAY**

THE MARK CONSISTS OF STANDARD CHARACTERS WITHOUT CLAIM TO ANY PARTICULAR FONT, STYLE, SIZE, OR COLOR.

NO CLAIM IS MADE TO THE EXCLUSIVE RIGHT TO USE "DISPLAY", APART FROM THE MARK AS SHOWN.

FOR CLEAR PLASTIC HOLDERS FOR BADGES; NON-METAL TRAIN AND BUS TICKET HOLDERS; NONMETAL HOLDERS FOR SIGNS; PLASTIC HOLDERS FOR SIGNBOARDS (U.S. CLS. 2, 13, 22, 25, 32 AND 50).

FIRST USE 10-1-2010; IN COMMERCE 10-1-2010.

LEIGH CAROLINE CASE, EXAMINING ATTORNEY

SN 85-153,698. HUFF, LINC, POINT ROBERTS, WA. FILED 10-15-2010.

**ATLAS**

THE MARK CONSISTS OF STANDARD CHARACTERS WITHOUT CLAIM TO ANY PARTICULAR FONT, STYLE, SIZE, OR COLOR.

FOR PORTABLE BACK SUPPORT CUSHION FOR USE IN CHAIRS, CAR SEATS, AND THE LIKE, NOT FOR MEDICAL PURPOSES (U.S. CLS. 2, 13, 22, 25, 32 AND 50).

FIRST USE 10-6-2010; IN COMMERCE 10-6-2010.

JAMES MACFARLANE, EXAMINING ATTORNEY

SN 85-155,008. THE PILLOW DOC, PORTSMOUTH, NH. FILED 10-18-2010.

**THE PILLOW DOC**

THE MARK CONSISTS OF STANDARD CHARACTERS WITHOUT CLAIM TO ANY PARTICULAR FONT, STYLE, SIZE, OR COLOR.

FOR BED PILLOWS (U.S. CLS. 2, 13, 22, 25, 32 AND 50).

FIRST USE 7-30-2010; IN COMMERCE 9-1-2010.

DANNEAN HETZEL, EXAMINING ATTORNEY

**CLASS 20—(Continued).**

SN 85-156,265. NEUTRAL POSTURE, INC., BRYAN, TX. FILED 10-19-2010.

**Chairs that Care**

THE MARK CONSISTS OF STANDARD CHARACTERS WITHOUT CLAIM TO ANY PARTICULAR FONT, STYLE, SIZE, OR COLOR.

NO CLAIM IS MADE TO THE EXCLUSIVE RIGHT TO USE "CHAIRS", APART FROM THE MARK AS SHOWN.

FOR CHAIRS; OFFICE CHAIRS (U.S. CLS. 2, 13, 22, 25, 32 AND 50).

FIRST USE 8-31-2010; IN COMMERCE 8-31-2010.

JAMES LOVELACE, EXAMINING ATTORNEY

SN 85-158,581. MICHELLE ELLEN CLINTON, SAN FRANCISCO, CA. FILED 10-21-2010.

**BELLA BEAN COUTURE**

THE MARK CONSISTS OF STANDARD CHARACTERS WITHOUT CLAIM TO ANY PARTICULAR FONT, STYLE, SIZE, OR COLOR.

NO CLAIM IS MADE TO THE EXCLUSIVE RIGHT TO USE "COUTURE", APART FROM THE MARK AS SHOWN.

THE NAME "BELLA BEAN" DOES NOT IDENTIFY A LIVING INDIVIDUAL.

FOR PET CUSHIONS (U.S. CLS. 2, 13, 22, 25, 32 AND 50).

FIRST USE 3-5-2010; IN COMMERCE 3-5-2010.

WILLIAM VERHOSEK, EXAMINING ATTORNEY

SN 85-174,087. CORREIA, PHYLLIS, SARASOTA, FL. FILED 11-10-2010.

**ANGEL WHISPERS**

THE MARK CONSISTS OF STANDARD CHARACTERS WITHOUT CLAIM TO ANY PARTICULAR FONT, STYLE, SIZE, OR COLOR.

FOR SEA SHELLS; WORKS OF ART OF WOOD (U.S. CLS. 2, 13, 22, 25, 32 AND 50).

NICHOLAS COLEMAN, EXAMINING ATTORNEY

**CLASS 20—(Continued).**

SN 85-174,433. HUNTER DOUGLAS INC., UPPER SADDLE RIVER, NJ. FILED 11-11-2010.

**ILLUMICELL**

THE MARK CONSISTS OF STANDARD CHARACTERS WITHOUT CLAIM TO ANY PARTICULAR FONT, STYLE, SIZE, OR COLOR.  
FOR WINDOW BLINDS; WINDOW SHADES (U.S. CLS. 2, 13, 22, 25, 32 AND 50).  
MARGERY A. TIERNEY, EXAMINING ATTORNEY

SN 85-177,851. STEVE MEDLEN, UKIAH, CA. FILED 11-16-2010.

**BabyBerm**

THE MARK CONSISTS OF STANDARD CHARACTERS WITHOUT CLAIM TO ANY PARTICULAR FONT, STYLE, SIZE, OR COLOR.  
FOR BABY BOLSTERS; BABY CHANGING MATS (U.S. CLS. 2, 13, 22, 25, 32 AND 50).  
CHRISTINE COOPER, EXAMINING ATTORNEY

SN 85-177,960. MICHAELA AND COMPANY, RAPID CITY, SD. FILED 11-16-2010.

**ALARRIAN**

THE MARK CONSISTS OF STANDARD CHARACTERS WITHOUT CLAIM TO ANY PARTICULAR FONT, STYLE, SIZE, OR COLOR.  
FOR HANGERS FOR CLOTHES (U.S. CLS. 2, 13, 22, 25, 32 AND 50).  
NAPOLEON SHARMA, EXAMINING ATTORNEY

**CLASS 20—(Continued).**

SN 85-178,038. STEELCASE INC., GRAND RAPIDS, MI. FILED 11-16-2010.

**BIVI**

THE MARK CONSISTS OF STANDARD CHARACTERS WITHOUT CLAIM TO ANY PARTICULAR FONT, STYLE, SIZE, OR COLOR.  
FOR OFFICE FURNITURE (U.S. CLS. 2, 13, 22, 25, 32 AND 50).  
JANICE KIM, EXAMINING ATTORNEY

SN 85-178,116. STEELCASE INC., GRAND RAPIDS, MI. FILED 11-16-2010.

**BE YOURSELF AT WORK**

THE MARK CONSISTS OF STANDARD CHARACTERS WITHOUT CLAIM TO ANY PARTICULAR FONT, STYLE, SIZE, OR COLOR.  
FOR OFFICE FURNITURE (U.S. CLS. 2, 13, 22, 25, 32 AND 50).  
JANICE KIM, EXAMINING ATTORNEY

SN 85-178,280. BLUMENTHAL DISTRIBUTING, INC., DBA OFFICE STAR PRODUCTS, ONTARIO, CA. FILED 11-16-2010.

**DuraFlex with Flow-Thru  
Technology**

THE MARK CONSISTS OF STANDARD CHARACTERS WITHOUT CLAIM TO ANY PARTICULAR FONT, STYLE, SIZE, OR COLOR.  
NO CLAIM IS MADE TO THE EXCLUSIVE RIGHT TO USE "TECHNOLOGY", APART FROM THE MARK AS SHOWN.  
FOR FABRIC SOLD AS AN INTEGRAL COMPONENT OF FINISHED FURNITURE, NAMELY, OFFICE CHAIRS (U.S. CLS. 2, 13, 22, 25, 32 AND 50).  
TASNEEM HUSSAIN, EXAMINING ATTORNEY

**CLASS 20—(Continued).**

SN 85-178,685. KE INVESTMENTS, LAS VEGAS, NV. FILED 11-17-2010.

**TIRELOFT**

THE MARK CONSISTS OF STANDARD CHARACTERS WITHOUT CLAIM TO ANY PARTICULAR FONT, STYLE, SIZE, OR COLOR.

FOR STORAGE RACKS (U.S. CLS. 2, 13, 22, 25, 32 AND 50).

DOMINIC J. FERRAIUOLO, EXAMINING ATTORNEY

**CLASS 20—(Continued).**

SN 85-179,290. PINNACLE FRAMES AND ACCENTS, INC., AUSTIN, TX. FILED 11-17-2010.

**CURATOR'S CHOICE**

THE MARK CONSISTS OF STANDARD CHARACTERS WITHOUT CLAIM TO ANY PARTICULAR FONT, STYLE, SIZE, OR COLOR.

FOR PICTURE AND PHOTOGRAPH FRAMES, AND WALL DÉCOR, NAMELY SHADOW BOXES, DISPLAY CASES AND SHELVING (U.S. CLS. 2, 13, 22, 25, 32 AND 50).

DAVID I, EXAMINING ATTORNEY

SN 85-178,837. JMH TRADING COMPANY INTERNATIONAL, EL PASO, TX. FILED 11-17-2010.

**Gather Craft**

THE MARK CONSISTS OF STANDARD CHARACTERS WITHOUT CLAIM TO ANY PARTICULAR FONT, STYLE, SIZE, OR COLOR.

FOR OUTDOOR FURNITURE; PATIO FURNITURE (U.S. CLS. 2, 13, 22, 25, 32 AND 50).

RONALD MCMORROW, EXAMINING ATTORNEY

SN 85-179,355. KE INVESTMENTS, LAS VEGAS, NV. FILED 11-17-2010.

**BINLOFT**

THE MARK CONSISTS OF STANDARD CHARACTERS WITHOUT CLAIM TO ANY PARTICULAR FONT, STYLE, SIZE, OR COLOR.

FOR RESIDENTIAL SHELVING UNITS AND COMPONENT PARTS THEREOF, NAMELY, SHELVES AND BRACKETS SOLD AS A UNIT; SHELVES; SHELVING; SHELVING AND COMPONENT PARTS THEREOF, NAMELY, SHELVES AND BRACKETS SOLD AS A UNIT (U.S. CLS. 2, 13, 22, 25, 32 AND 50).

DOMINIC J. FERRAIUOLO, EXAMINING ATTORNEY

SN 85-179,024. DRIFT STUDIO, LLC, MADISON, WI. FILED 11-17-2010.

**DRIFT**

THE MARK CONSISTS OF STANDARD CHARACTERS WITHOUT CLAIM TO ANY PARTICULAR FONT, STYLE, SIZE, OR COLOR.

FOR FURNITURE (U.S. CLS. 2, 13, 22, 25, 32 AND 50).

KAREN K. BUSH, EXAMINING ATTORNEY

SN 85-181,850. KE INVESTMENTS, LAS VEGAS, NV. FILED 11-20-2010.

**POWERLOFT**

THE MARK CONSISTS OF STANDARD CHARACTERS WITHOUT CLAIM TO ANY PARTICULAR FONT, STYLE, SIZE, OR COLOR.

FOR SHELVES; SHELVING AND COMPONENT PARTS THEREOF, NAMELY, SHELVES AND BRACKETS SOLD AS A UNIT (U.S. CLS. 2, 13, 22, 25, 32 AND 50).

DOMINIC J. FERRAIUOLO, EXAMINING ATTORNEY

**CLASS 20—(Continued).**

SN 85-184,957. HUNTER DOUGLAS INC., UPPER SADDLE RIVER, NJ. FILED 11-24-2010.

**NATURAL ELEMENTS**

THE MARK CONSISTS OF STANDARD CHARACTERS WITHOUT CLAIM TO ANY PARTICULAR FONT, STYLE, SIZE, OR COLOR.

FOR WINDOW BLINDS; WINDOW SHADES (U.S. CLS. 2, 13, 22, 25, 32 AND 50).

MARGERY A. TIERNEY, EXAMINING ATTORNEY



SN 85-184,968. HUNTER DOUGLAS INC., BROOMFIELD, CO. FILED 11-24-2010.

**RIVERSTONE**

THE MARK CONSISTS OF STANDARD CHARACTERS WITHOUT CLAIM TO ANY PARTICULAR FONT, STYLE, SIZE, OR COLOR.

FOR WINDOW BLINDS; WINDOW SHADES (U.S. CLS. 2, 13, 22, 25, 32 AND 50).

MARGERY A. TIERNEY, EXAMINING ATTORNEY



SN 85-207,148. FOOT LEVELERS, INC., ROANOKE, VA. FILED 12-29-2010.

**SUREREST**

THE MARK CONSISTS OF STANDARD CHARACTERS WITHOUT CLAIM TO ANY PARTICULAR FONT, STYLE, SIZE, OR COLOR.

FOR PILLOWS (U.S. CLS. 2, 13, 22, 25, 32 AND 50).

JIM RINGLE, EXAMINING ATTORNEY

**CLASS 20—(Continued).**

SN 85-207,552. GANZ, WOODBRIDGE, ONT, CANADA, FILED 12-29-2010.

**AMAZING WORLD**

THE MARK CONSISTS OF STANDARD CHARACTERS WITHOUT CLAIM TO ANY PARTICULAR FONT, STYLE, SIZE, OR COLOR.

FOR COLD CAST RESIN FIGURINES, NON-METAL KEY CHAINS AND NON-LEATHER KEY CHAINS; ORNAMENTS MADE OF COLD CAST RESIN NOT CHRISTMAS TREE ORNAMENTS, PLASTIC AND WOOD BOXES, PLASTIC CAKE DECORATIONS, PICTURE FRAMES, PILLOWS (U.S. CLS. 2, 13, 22, 25, 32 AND 50).

JENNY PARK, EXAMINING ATTORNEY



**CLASS 21—HOUSEWARES AND GLASS**

SN 76-630,101. HASLAM, DARRELL, OSHAWA, ONTARIO, CANADA, FILED 2-1-2005.

**BOTTLE MATE**

THE MARK CONSISTS OF STANDARD CHARACTERS WITHOUT CLAIM TO ANY PARTICULAR FONT, STYLE, SIZE, OR COLOR.

PRIORITY CLAIMED UNDER SEC. 44(D) ON CANADA APPLICATION NO. 1,231,204, FILED 9-21-2004.

NO CLAIM IS MADE TO THE EXCLUSIVE RIGHT TO USE "BOTTLE", APART FROM THE MARK AS SHOWN.

FOR BABY BOTTLE RETENTION STRAPS (U.S. CLS. 2, 13, 23, 29, 30, 33, 40 AND 50).

ALICIA COLLINS, EXAMINING ATTORNEY

**CLASS 21—(Continued).**

SN 77-931,465. W2007 STRATOSPHERE PROPCO, L.P., LAS VEGAS, NV. FILED 2-9-2010.



OWNER OF U.S. REG. NOS. 2,086,400, 2,086,401 AND 3,212,812.

NO CLAIM IS MADE TO THE EXCLUSIVE RIGHT TO USE "LAS VEGAS", APART FROM THE MARK AS SHOWN.

THE MARK CONSISTS OF THE WORDS "SKY JUMP STRATOSPHERE LAS VEGAS" STAGGERED AND VERTICALLY POSITIONED OVER A TARGET.

FOR BEVERAGeware; BOTTLE OPENERS; COASTERS NOT OF PAPER AND NOT BEING TABLE LINEN; CONTAINERS FOR HOUSEHOLD OR KITCHEN USE; FIGURINES OF GLASS AND CERAMIC; FLASKS; PLASTIC WATER BOTTLES SOLD EMPTY; PLATES; SHOT GLASSES (U.S. CLS. 2, 13, 23, 29, 30, 33, 40 AND 50).

PAUL E. FAHRENKOPF, EXAMINING ATTORNEY

**CLASS 21—(Continued).**

SN 79-081,496. SMASH ENTERPRISES PTY LTD, MITCHAM VIC 3132, AUSTRALIA, FILED 2-25-2010.

**NUDE FOOD MOVERS**

THE MARK CONSISTS OF STANDARD CHARACTERS WITHOUT CLAIM TO ANY PARTICULAR FONT, STYLE, SIZE, OR COLOR.

OWNER OF INTERNATIONAL REGISTRATION 1035769 DATED 2-25-2010, EXPIRES 2-25-2020.

NO CLAIM IS MADE TO THE EXCLUSIVE RIGHT TO USE "FOOD", APART FROM THE MARK AS SHOWN.

FOR CONTAINERS WITH OR WITHOUT LIDS FOR HOUSEHOLD USE; FLEXIBLE OR RIGID, INSULATED OR NON INSULATED CONTAINERS FOR FOOD OR BEVERAGES FOR DOMESTIC USE; ISOTHERMIC BAGS FOR FOOD OR BEVERAGES FOR DOMESTIC USE; BOTTLES SOLD EMPTY; PLASTIC STORAGE CONTAINERS FOR DOMESTIC USE; LUNCH BOXES (U.S. CLS. 2, 13, 23, 29, 30, 33, 40 AND 50).

PAULA MAHONEY, EXAMINING ATTORNEY

SN 79-063,417. PORCELANAS DA COSTA VERDE, S.A., VAGOS, PORTUGAL, FILED 11-14-2008.

costaverde

PRIORITY DATE OF 5-14-2008 IS CLAIMED.

OWNER OF INTERNATIONAL REGISTRATION 0988330 DATED 11-14-2008, EXPIRES 11-14-2018.

THE COLOR(S) BLACK AND GREEN IS/ARE CLAIMED AS A FEATURE OF THE MARK.

THE MARK CONSISTS OF THE COMPOUND WORDING "COSTAVERDE" IN LOWER CASE LETTERS, WITH "COSTA" APPEARING IN THE COLOR BLACK, AND "VERDE" APPEARING IN THE COLOR GREEN.

THE ENGLISH TRANSLATION OF THE WORD "COSTAVERDE" IN THE MARK IS "GREEN COAST".

FOR ART AND DECORATIVE OBJECTS IN CERAMIC, PORCELAIN, EARTHENWARE, GLASS AND CRYSTAL, NAMELY, MEAL TRAYS, CERAMIC TISSUE BOX COVERS, VASES, FLASKS; DEVICES ARID RECIPIENTS FOR DOMESTIC USE AND FOR KITCHEN PURPOSES IN GLASS, CRYSTAL, CERAMIC AND PORCELAIN, NAMELY, DINNERWARE FOR BOTH DOMESTIC AND CATERING PURPOSES, NAMELY, PLATES, CUPS, MUGS, BOWLS, SOUP TUREENS, SAUCERS, COFFEE AND TEA CUPS AND SAUCERS, SUGAR BOWLS, MILK JUGS, NON-ELECTRIC COFFEE AND TEA POTS, DINNER SETS COMPRISING DINNER PLATES AND SALAD PLATES, TEA SETS ARID COFFEE SETS COMPRISING NON-ELECTRIC COFFEE POT AND COFFEE CUPS (U.S. CLS. 2, 13, 23, 29, 30, 33, 40 AND 50).

ODESSA BIBBINS, EXAMINING ATTORNEY

SN 79-087,023. RECKITT BENCKISER N.V., NETHERLANDS, FILED 8-23-2010.

**QUANTUMATIC**

THE MARK CONSISTS OF STANDARD CHARACTERS WITHOUT CLAIM TO ANY PARTICULAR FONT, STYLE, SIZE, OR COLOR.

PRIORITY DATE OF 2-23-2010 IS CLAIMED.

OWNER OF INTERNATIONAL REGISTRATION 1050232 DATED 8-23-2010, EXPIRES 8-23-2020.

OWNER OF U.S. REG. NO. 3,793,615.

FOR CONTAINERS FOR HOUSEHOLD OR KITCHEN USE; DISPENSERS FOR CLEANING PREPARATIONS; DISPENSERS FOR DISHWASHING DETERGENT; PARTS AND FITTINGS FOR ALL THE AFORESAID GOODS, SOLD AS A UNIT THEREWITH (U.S. CLS. 2, 13, 23, 29, 30, 33, 40 AND 50).

JOHN KELLY, EXAMINING ATTORNEY



**CLASS 21—(Continued).**

SN 85-016,035. THOSE CHARACTERS FROM CLEVELAND, INC., CLEVELAND, OH. FILED 4-16-2010.

# CARE BEARS

THE MARK CONSISTS OF STANDARD CHARACTERS WITHOUT CLAIM TO ANY PARTICULAR FONT, STYLE, SIZE, OR COLOR.

FOR BABY BATH TUBS, NON-METAL PIGGY BANKS, BEVERAGE GLASSES, BOWLS, CAKE MOLD, CAKE PANS, CANTEENS, CUPCAKE PANS, COMBS, COOKIE CUTTERS, COOKIE JARS, PORTABLE COOLERS, CUPS, DECORATIVE GLASS BOXES, DECORATIVE PLATES, DINNERWARE, DISHES, DRINKING GLASSES, TOOTHBRUSHES, CAMPING GRILLS, FITTED PICNIC BASKETS, HAIR BRUSHES, INSULATING SLEEVE HOLDERS FOR DRINK CANS AND BOTTLES, LUNCH BOXES, LUNCH KIT CONSISTING OF LUNCH BOXES AND THERMAL INSULATED CONTAINERS, MUGS, PAPER CUPS, PAPER PLATES, PITCHERS, PLASTIC COASTERS, PLASTIC CUPS, PLASTIC PLATES, PLASTIC SERVING TRAYS, PLATES, SOAP CONTAINERS, TOOTHBRUSH CASES, TOOTHBRUSH HOLDERS, TRAYS, VASES, WASTEPAPER BASKETS, WATERING CANS (U.S. CLS. 2, 13, 23, 29, 30, 33, 40 AND 50).

JANICE KIM, EXAMINING ATTORNEY

**CLASS 21—(Continued).**

SN 85-049,798. DISNEY ENTERPRISES, INC., BURBANK, CA. FILED 5-27-2010.

# DISNEY CALIFORNIA ADVENTURE

THE MARK CONSISTS OF STANDARD CHARACTERS WITHOUT CLAIM TO ANY PARTICULAR FONT, STYLE, SIZE, OR COLOR.

OWNER OF U.S. REG. NOS. 3,361,031, 3,683,565 AND OTHERS.

NO CLAIM IS MADE TO THE EXCLUSIVE RIGHT TO USE "CALIFORNIA", APART FROM THE MARK AS SHOWN.

FOR BEVERAGEWARE; BEVERAGE GLASSWARE; BOWLS; BROOMS; CAKE PANS; CAKE MOLDS; CAKE SERVERS; CANDLE HOLDERS NOT OF PRECIOUS METAL; CANDLE SNUFFERS; CANDLESTICKS; CANTEENS; COASTERS NOT OF PAPER AND NOT BEING TABLE LINEN; COOKIE JARS; COOKIE CUTTERS; CORK SCREWS; CUPS; DECORATING BAGS FOR CONFECTIONERS; DECORATIVE CRYSTAL PRISMS; DECORATIVE GLASS NOT FOR BUILDING; DECORATIVE PLATES; DINNERWARE; DISHES; FIGURINES MADE OF CERAMIC, CHINA, CRYSTAL, EARTHENWARE, GLASS, OR PORCELAIN; HAIR BRUSHES; HAIR COMBS; HEAT-INSULATED VESSELS; HOUSEHOLD CONTAINERS FOR FOOD AND BEVERAGES; INSULATING SLEEVE HOLDERS FOR BEVERAGE CONTAINERS; LUNCH BOXES; MUGS; NAPKIN HOLDERS; NAPKIN RINGS NOT OF PRECIOUS METALS; PAPER CUPS; PAPER PLATES; PIE PANS; PIE SERVERS; PLASTIC CUPS; PLATES; SPORTS BOTTLES SOLD EMPTY; SOAP DISHES; TEA KETTLES; TEA SETS; THERMAL INSULATED CONTAINERS FOR FOOD OR BEVERAGE; TOOTHBRUSHES; TRAYS NOT OF PRECIOUS METAL; TRIVETS; VACUUM BOTTLES; WASTE BASKETS (U.S. CLS. 2, 13, 23, 29, 30, 33, 40 AND 50).

AMY HELLA, EXAMINING ATTORNEY

SN 85-032,893. BRANDED TRAY LLC, GREENWICH, CT. FILED 5-7-2010.

# BRANDED

THE MARK CONSISTS OF STANDARD CHARACTERS WITHOUT CLAIM TO ANY PARTICULAR FONT, STYLE, SIZE, OR COLOR.

FOR BUTLERS' TRAYS; MEAL TRAYS; PAPER TRAYS; SERVING TRAYS; SERVING TRAYS NOT OF PRECIOUS METAL; TRAYS FOR DOMESTIC PURPOSES (U.S. CLS. 2, 13, 23, 29, 30, 33, 40 AND 50).

FIRST USE 4-20-2008; IN COMMERCE 4-20-2008. DAVID C. REIHNER, EXAMINING ATTORNEY

SN 85-074,618. 1682796 ONTARIO INC., TORONTO, ONTARIO, CANADA, FILED 6-30-2010.

# BEST IN ... BRUSH

THE MARK CONSISTS OF STANDARD CHARACTERS WITHOUT CLAIM TO ANY PARTICULAR FONT, STYLE, SIZE, OR COLOR.

NO CLAIM IS MADE TO THE EXCLUSIVE RIGHT TO USE "BRUSH", APART FROM THE MARK AS SHOWN.

FOR BRUSHES FOR PETS; ELECTRIC PET BRUSHES; GROOMING TOOLS FOR PETS, NAMELY, COMBS AND BRUSHES; PET BRUSHES (U.S. CLS. 2, 13, 23, 29, 30, 33, 40 AND 50).

RON FAIRBANKS, EXAMINING ATTORNEY

**CLASS 21—(Continued).**

SN 85-093,342. SENNABELLA DESIGNS LLC, OLYMPIA, WA. FILED 7-26-2010.

SENNABELLA DESIGNS LLC  
DON'T ARRIVE WITH A BARE  
NECK!

THE MARK CONSISTS OF STANDARD CHARACTERS WITHOUT CLAIM TO ANY PARTICULAR FONT, STYLE, SIZE, OR COLOR.

NO CLAIM IS MADE TO THE EXCLUSIVE RIGHT TO USE "DESIGNS LLC", APART FROM THE MARK AS SHOWN.

FOR BEADED NECKLACES SPECIALLY ADAPTED FOR DECORATING WINE BOTTLES (U.S. CLS. 2, 13, 23, 29, 30, 33, 40 AND 50).

REBECCA EISINGER, EXAMINING ATTORNEY

---

SN 85-120,582. PEREZ, RALPH, EDGEWATER, NJ. FILED 9-1-2010.

WIPE-OUT ERASER

THE MARK CONSISTS OF STANDARD CHARACTERS WITHOUT CLAIM TO ANY PARTICULAR FONT, STYLE, SIZE, OR COLOR.

NO CLAIM IS MADE TO THE EXCLUSIVE RIGHT TO USE "ERASER", APART FROM THE MARK AS SHOWN.

FOR CLEANING SPONGES; SCRUB SPONGES; SPONGES FOR HOUSEHOLD PURPOSES (U.S. CLS. 2, 13, 23, 29, 30, 33, 40 AND 50).

FIRST USE 8-7-2009; IN COMMERCE 8-7-2009.  
INGA ERVIN, EXAMINING ATTORNEY

---

SN 85-136,405. OVERDEVEST NURSERIES, L.P., BRIDGE-TON, NJ. FILED 9-23-2010.

e-Pot

THE MARK CONSISTS OF STANDARD CHARACTERS WITHOUT CLAIM TO ANY PARTICULAR FONT, STYLE, SIZE, OR COLOR.

FOR FLOWER AND PLANT POTS MADE OF BIODEGRADABLE MATERIAL FOR HORTICULTURE (U.S. CLS. 2, 13, 23, 29, 30, 33, 40 AND 50).

SKYE YOUNG, EXAMINING ATTORNEY

**CLASS 21—(Continued).**

SN 85-151,984. DESIGN DIRECTIVE INC., KITCHENER, ONTARIO, CANADA, FILED 10-13-2010.

GARDEN365

THE MARK CONSISTS OF STANDARD CHARACTERS WITHOUT CLAIM TO ANY PARTICULAR FONT, STYLE, SIZE, OR COLOR.

FOR PLANTERS FOR FLOWERS AND PLANTS (U.S. CLS. 2, 13, 23, 29, 30, 33, 40 AND 50).

FIRST USE 2-1-2010; IN COMMERCE 3-1-2010.  
APRIL ROACH, EXAMINING ATTORNEY

---

SN 85-153,265. LAFLIN, BARBARA DIAZ, OCEAN RIDGE, FL. FILED 10-15-2010.

omni  
WIPE

NO CLAIM IS MADE TO THE EXCLUSIVE RIGHT TO USE "WIPE", APART FROM THE MARK AS SHOWN.

THE MARK CONSISTS OF THE STYLIZED WORDING "OMNI WIPE" WHERE THE WORD "OMNI" IS POSITIONED DIRECTLY ABOVE THE WORD "WIPE".

FOR CONTAINERS FOR HOUSEHOLD USE, NAMELY, FOR STORING DISPOSABLE WIPES IMPREGNATED WITH CLEANSING CHEMICALS OR COMPOUNDS FOR HOUSEHOLD USE (U.S. CLS. 2, 13, 23, 29, 30, 33, 40 AND 50).

COURTNEY ALVAREZ, EXAMINING ATTORNEY

**CLASS 21—(Continued).**

SN 85-153,972. HUANG, CHUN, MARKHAM, ON., CANADA, FILED 10-15-2010.

MAGIC LOOFAH  
神奇絲瓜絡

NO CLAIM IS MADE TO THE EXCLUSIVE RIGHT TO USE NON-LATIN CHARACTERS THAT TRANSLITERATE TO SI GUA LUO AND THE WORDING "LOOFAH", APART FROM THE MARK AS SHOWN.

THE MARK CONSISTS OF LETTERS OF "MAGIC LOOFAH", AND FIVE CHINESE CHARACTERS IN THE MEANING OF "MAGIC LOOFAH".

THE ENGLISH TRANSLATION OF SHEN QI SI GUA LUO IN THE MARK IS "MAGIC LOOFAH".

THE NON-LATIN CHARACTERS IN THE MARK TRANSLITERATE TO SHEN QI SI GUA LUO AND THIS MEANS "MAGIC LOOFAH" IN ENGLISH.

FOR BATH PRODUCTS, NAMELY, LOOFAH SPONGES; LOOFAHS FOR HOUSEHOLD PURPOSES (U.S. CLS. 2, 13, 23, 29, 30, 33, 40 AND 50).

ALEX KEAM, EXAMINING ATTORNEY

**CLASS 21—(Continued).**

SN 85-155,641. POWER BOMBER, LLC, ELLICOTT CITY, MD. FILED 10-19-2010.



THE MARK CONSISTS OF TWO STYLIZED DRINKING GLASSES COMPRISING V-SHAPED DESIGNS WITH FLAT BOTTOMS ABOVE THE STYLIZED WORDING "POWER-BOMBER".

FOR BEVERAGE GLASSWARE (U.S. CLS. 2, 13, 23, 29, 30, 33, 40 AND 50).

FIRST USE 3-1-2009; IN COMMERCE 4-1-2009.  
KRISTINA MORRIS, EXAMINING ATTORNEY

SN 85-156,772. METROPLEX SERVICES, INC., MASON, OH. FILED 10-20-2010.

SN 85-155,046. WELCH, JENNIFER, BELLEAIR BLUFFS, FL. FILED 10-18-2010.

KEY WESCUE



NO CLAIM IS MADE TO THE EXCLUSIVE RIGHT TO USE "WINE BALLOON" AND "THE WINE PRESERVER", APART FROM THE MARK AS SHOWN.

THE MARK CONSISTS OF A STYLIZED SEAL WITH A SCRIPT "W" AND "B" WITHIN A CENTER CIRCLE, AS WELL AS THE TERMS "WINE BALLOON" AND "THE WINE PRESERVER" AROUND THE CENTER CIRCLE.

FOR APPARATUS FOR SEALING THE INTERIOR OF A WINE BOTTLE TO PROTECT WINE FROM OXIDATION (U.S. CLS. 2, 13, 23, 29, 30, 33, 40 AND 50).

FIRST USE 9-28-2010; IN COMMERCE 9-28-2010.  
CARYN GLASSER, EXAMINING ATTORNEY

THE MARK CONSISTS OF STANDARD CHARACTERS WITHOUT CLAIM TO ANY PARTICULAR FONT, STYLE, SIZE, OR COLOR.

FOR GLASSWARE, NAMELY, MUGS AND DRINKING GLASSES OF VARIOUS SIZES AND VOLUME (U.S. CLS. 2, 13, 23, 29, 30, 33, 40 AND 50).

PAM WILLIS, EXAMINING ATTORNEY

**CLASS 21—(Continued).**

SN 85-157,806. TAKE 3 TACO LLC, PHOENIX, AZ. FILED 10-21-2010.

# TAKE 3 TACO

THE MARK CONSISTS OF STANDARD CHARACTERS WITHOUT CLAIM TO ANY PARTICULAR FONT, STYLE, SIZE, OR COLOR.

NO CLAIM IS MADE TO THE EXCLUSIVE RIGHT TO USE "TACO", APART FROM THE MARK AS SHOWN.

FOR DINNERWARE, NAMELY, PLATES, BOWLS, SERVING PLATTERS, SERVING BOWLS, CUPS, SAUCERS, AND BEVERAGE GLASSWARE (U.S. CLS. 2, 13, 23, 29, 30, 33, 40 AND 50).

MICHAEL TANNER, EXAMINING ATTORNEY

SN 85-161,083. SPIKER INC., TALLAHASSEE, FL. FILED 10-26-2010.



THE MARK CONSISTS OF THE TERM "SPIKER" IN A CUSTOM FONT ON AN OVAL BACKGROUND.

FOR SPORTS BOTTLES SOLD EMPTY (U.S. CLS. 2, 13, 23, 29, 30, 33, 40 AND 50).

FIRST USE 7-11-1988; IN COMMERCE 6-26-1990.

KAREN K. BUSH, EXAMINING ATTORNEY

SN 85-161,629. CERTAINTTEED CORPORATION, VALLEY FORGE, PA. FILED 10-26-2010.

# INSULSORB

THE MARK CONSISTS OF STANDARD CHARACTERS WITHOUT CLAIM TO ANY PARTICULAR FONT, STYLE, SIZE, OR COLOR.

FOR ABSORBENT MATERIAL, NAMELY, FIBER-GLASS BLOWING WOOL NOT FOR INSULATION, FOR USE IN CONNECTION WITH CLEANING OIL SPILLS (U.S. CLS. 2, 13, 23, 29, 30, 33, 40 AND 50).

FIRST USE 10-0-2008; IN COMMERCE 10-0-2008.

CAROL SPILS, EXAMINING ATTORNEY

**CLASS 21—(Continued).**

SN 85-163,102. CERASANI, ANTHONY, LOLO, MT. FILED 10-27-2010.



THE MARK CONSISTS OF A CYCLONE-LIKE DESIGN ABOVE THE WORDING "CYCLONECUP".

FOR PLASTIC COVERED SHAKER BOTTLE SOLD EMPTY FOR MIXING AND SHAKING POWDERS AND LIQUIDS FOR THE PURPOSE OF DRINKING (U.S. CLS. 2, 13, 23, 29, 30, 33, 40 AND 50).

DAWN HAN, EXAMINING ATTORNEY

SN 85-175,532. WINE VEIL, LLC, DENVER, CO. FILED 11-12-2010.



NO CLAIM IS MADE TO THE EXCLUSIVE RIGHT TO USE "WINE", APART FROM THE MARK AS SHOWN.

THE MARK CONSISTS OF AN ILLUSTRATION OF A WINE GLASS WITH A PIECE OF FABRIC OVER THE TOP OF THE GLASS, AND AN INSECT FLYING OVER THE GLASS. THE LANGUAGE "WINE VEIL" APPEARS TO THE RIGHT OF THE ILLUSTRATION OF THE GLASS.

FOR WINE ACCESSORY, NAMELY, A SQUARE OF FABRIC WEIGHTED IN EACH OF THE FOUR CORNERS WITH BEADS, BUTTONS, AND CHARMS, FOR THE PURPOSE OF PLACING OVER A WINE GLASS (U.S. CLS. 2, 13, 23, 29, 30, 33, 40 AND 50).

FIRST USE 11-1-2010; IN COMMERCE 11-1-2010.

LAURIE MAYES, EXAMINING ATTORNEY

SN 85-176,039. BREWZKEY, MOUNTAIN VIEW, CA. FILED 11-12-2010.

# BREWZKEY

THE MARK CONSISTS OF STANDARD CHARACTERS WITHOUT CLAIM TO ANY PARTICULAR FONT, STYLE, SIZE, OR COLOR.

FOR BOTTLE OPENERS (U.S. CLS. 2, 13, 23, 29, 30, 33, 40 AND 50).

FIRST USE 10-27-2006; IN COMMERCE 10-27-2006.

DOMINIC J. FERRAIUOLO, EXAMINING ATTORNEY

**CLASS 21—(Continued).**

SN 85-177,883. ANDERSON, ROBERT MICHAEL, CENTREVILLE, VA. FILED 11-16-2010.

# Shoo-in

THE MARK CONSISTS OF STANDARD CHARACTERS WITHOUT CLAIM TO ANY PARTICULAR FONT, STYLE, SIZE, OR COLOR.

FOR SHOE HORNS (U.S. CLS. 2, 13, 23, 29, 30, 33, 40 AND 50).

SUE LAWRENCE, EXAMINING ATTORNEY

---

SN 85-178,108. ARCTIC INNOVATIONS, ANCHORAGE, AK. FILED 11-16-2010.

# HydroHeater

THE MARK CONSISTS OF STANDARD CHARACTERS WITHOUT CLAIM TO ANY PARTICULAR FONT, STYLE, SIZE, OR COLOR.

FOR PERSONAL FLUID HYDRATION SYSTEMS COMPRISING A FLUID RESERVOIR, A DELIVERY TUBE, A MOUTHPIECE AND A CARRYING PACK (U.S. CLS. 2, 13, 23, 29, 30, 33, 40 AND 50).

JENNY PARK, EXAMINING ATTORNEY

---

SN 85-178,208. PROGRESSIVE INTERNATIONAL CORPORATION, KENT, WA. FILED 11-16-2010.

# S4

THE MARK CONSISTS OF STANDARD CHARACTERS WITHOUT CLAIM TO ANY PARTICULAR FONT, STYLE, SIZE, OR COLOR.

FOR CHEESE GRATERS; COOKING GRATERS; GRATERS FOR HOUSEHOLD PURPOSES (U.S. CLS. 2, 13, 23, 29, 30, 33, 40 AND 50).

ANTHONY RINKER, EXAMINING ATTORNEY

**CLASS 21—(Continued).**

SN 85-178,231. PROGRESSIVE INTERNATIONAL CORPORATION, KENT, WA. FILED 11-16-2010.



THE MARK CONSISTS OF THE LETTER "S" WITH SUBSCRIPT NUMBER "4" INSIDE A SHADED PARALLELOGRAM.

FOR CHEESE GRATERS; COOKING GRATERS; GRATERS FOR HOUSEHOLD PURPOSES (U.S. CLS. 2, 13, 23, 29, 30, 33, 40 AND 50).

ANTHONY RINKER, EXAMINING ATTORNEY

---

SN 85-179,030. PETERSON, ROBERT KAIDO, WEST BROOKFIELD, MA. FILED 11-17-2010.

# OTO

THE MARK CONSISTS OF STANDARD CHARACTERS WITHOUT CLAIM TO ANY PARTICULAR FONT, STYLE, SIZE, OR COLOR.

FOR THERMAL INSULATED CONTAINERS FOR FOOD OR BEVERAGES (U.S. CLS. 2, 13, 23, 29, 30, 33, 40 AND 50).

LINDA MICKLEBURGH, EXAMINING ATTORNEY

---

SN 85-179,512. LIDDUP CORPORATION, LAS VEGAS, NV. FILED 11-17-2010.

# LIDDUP

THE MARK CONSISTS OF STANDARD CHARACTERS WITHOUT CLAIM TO ANY PARTICULAR FONT, STYLE, SIZE, OR COLOR.

FOR PORTABLE COOLERS; PORTABLE ICE CHESTS FOR FOOD AND BEVERAGES (U.S. CLS. 2, 13, 23, 29, 30, 33, 40 AND 50).

CAROL SPILS, EXAMINING ATTORNEY

**CLASS 21—(Continued).**

SN 85-179,863. BAGGIE HELPER, LLC, SHERIDAN, WY.  
FILED 11-18-2010.

**BAGWELL**

THE MARK CONSISTS OF STANDARD CHARACTERS WITHOUT CLAIM TO ANY PARTICULAR FONT, STYLE, SIZE, OR COLOR.

FOR NON-METAL COLLAPSIBLE, PORTABLE DEVICE FOR HOLDING A BAGGIE OPEN SO THAT IT CAN BE FILLED (U.S. CLS. 2, 13, 23, 29, 30, 33, 40 AND 50).

FIRST USE 11-17-2010; IN COMMERCE 11-17-2010.  
WILLIAM P. SHANAHAN, EXAMINING ATTORNEY

SN 85-180,028. GLOBAL ADVANTAGE TRADING AND IMPORTS, LLC, LAKE ST LOUIS, MO. FILED 11-18-2010.

**LifeCycle**

THE MARK CONSISTS OF STANDARD CHARACTERS WITHOUT CLAIM TO ANY PARTICULAR FONT, STYLE, SIZE, OR COLOR.

FOR BOTTLES, SOLD EMPTY; PLASTIC WATER BOTTLES SOLD EMPTY; REUSABLE PLASTIC WATER BOTTLES SOLD EMPTY; REUSABLE STAINLESS STEEL WATER BOTTLES SOLD EMPTY; SPORTS BOTTLES SOLD EMPTY; VACUUM BOTTLES (U.S. CLS. 2, 13, 23, 29, 30, 33, 40 AND 50).

FIRST USE 7-3-2010; IN COMMERCE 7-3-2010.  
REBECCA POVARCHUK, EXAMINING ATTORNEY

SN 85-180,722. GRAVITY GROUP, INC., WEST ALLIS, WI.  
FILED 11-19-2010.

**Flat Tire**

THE MARK CONSISTS OF STANDARD CHARACTERS WITHOUT CLAIM TO ANY PARTICULAR FONT, STYLE, SIZE, OR COLOR.

OWNER OF U.S. REG. NOS. 3,088,749 AND 3,581,812.  
FOR BASKETS FOR DOMESTIC USE, NOT OF METAL; BASKETS OF RECYCLED TIRE RUBBER; COASTERS, NOT OF PAPER AND OTHER THAN TABLE LINEN (U.S. CLS. 2, 13, 23, 29, 30, 33, 40 AND 50).  
SUE LAWRENCE, EXAMINING ATTORNEY

**CLASS 21—(Continued).**

SN 85-181,081. THE ROCK LINK, INC., NEW YORK, NY.  
FILED 11-19-2010.

**Remind-A-Cap**

THE MARK CONSISTS OF STANDARD CHARACTERS WITHOUT CLAIM TO ANY PARTICULAR FONT, STYLE, SIZE, OR COLOR.

FOR BOTTLES FOR PHARMACEUTICALS SOLD EMPTY (U.S. CLS. 2, 13, 23, 29, 30, 33, 40 AND 50).  
INGRID C. EULIN, EXAMINING ATTORNEY

SN 85-200,094. THE FRANK LLOYD WRIGHT FOUNDATION, SCOTTSDALE, AZ. FILED 12-16-2010.

**FRANK LLOYD WRIGHT**

THE MARK CONSISTS OF STANDARD CHARACTERS WITHOUT CLAIM TO ANY PARTICULAR FONT, STYLE, SIZE, OR COLOR.

OWNER OF U.S. REG. NOS. 1,022,648, 1,871,719 AND OTHERS.

FOR BOWLS; CANDLE HOLDERS; CERAMIC SCULPTURES, VASES, VESSELS, BOWLS, PLATES AND POTS; COASTERS NOT OF PAPER AND NOT BEING TABLE LINEN; CREAM AND SUGAR SET; CUPS AND MUGS; DECORATIVE CERAMIC TILES NOT FOR USE AS BUILDING MATERIALS; DINNERWARE, NAMELY, EARTHENWARE, TERRA COTTA, PORCELAIN, CHINA; DRINKING GLASSES; FIGURES OF TERRA COTTA, PORCELAIN; FLOOR VASES; HOLDERS FOR FLOWERS AND PLANTS; NAPKIN RINGS NOT OF PRECIOUS METALS; SALT AND PEPPER SHAKERS; SCULPTURES OF GLASS, CRYSTAL, TERRA COTTA, PORCELAIN; STAINED GLASS; SUGAR BOWLS; VASES; WORKS OF ART OF GLASS, PORCELAIN, TERRA COTTA (U.S. CLS. 2, 13, 23, 29, 30, 33, 40 AND 50).

FIRST USE 12-10-1986; IN COMMERCE 12-10-1986.  
LAURIE MAYES, EXAMINING ATTORNEY

SN 85-221,883. HEB GROCERY COMPANY, LP, SAN ANTONIO, TX. FILED 1-20-2011.

**Ahh!Grip**

THE MARK CONSISTS OF STANDARD CHARACTERS WITHOUT CLAIM TO ANY PARTICULAR FONT, STYLE, SIZE, OR COLOR.

OWNER OF U.S. REG. NO. 3,880,516.  
FOR DUSTERS (U.S. CLS. 2, 13, 23, 29, 30, 33, 40 AND 50).  
STEVEN JACKSON, EXAMINING ATTORNEY

**CLASS 22—CORDAGE AND FIBERS**

SN 77-409,375. 1047454 ONTARIO INC., LONDON, CANADA,  
FILED 2-29-2008.

# SWIMWERX

THE MARK CONSISTS OF STANDARD CHARACTERS WITHOUT CLAIM TO ANY PARTICULAR FONT, STYLE, SIZE, OR COLOR.

PRIORITY CLAIMED UNDER SEC. 44(D) ON CANADA APPLICATION NO. 1384694, FILED 2-25-2008, REG. NO. TMA790,627, DATED 2-14-2011, EXPIRES 2-14-2026.

FOR SWIMMING POOL ACCESSORIES, NAMELY, ABOVEGROUND AND INGROUND POOL LINERS MADE OF VINYL (U.S. CLS. 1, 2, 7, 19, 22, 42 AND 50).  
MORGAN WYNNE, EXAMINING ATTORNEY

**CLASS 24—(Continued).**

SN 77-151,499. STANDARD TEXTILE CO., INC., CINCINNATI, OH. FILED 4-9-2007.

# DUKE

THE MARK CONSISTS OF STANDARD CHARACTERS WITHOUT CLAIM TO ANY PARTICULAR FONT, STYLE, SIZE, OR COLOR.

FOR BED BLANKETS USED IN THE HEALTHCARE INDUSTRY (U.S. CLS. 42 AND 50).

FIRST USE 0-0-1987; IN COMMERCE 0-0-1987.  
DARRYL SPRUILL, EXAMINING ATTORNEY

**CLASS 23—YARNS AND THREADS**

SN 85-185,006. HOBBY LOBBY STORES, INC., OKLAHOMA CITY, OK. FILED 11-24-2010.

# ARTISTE

THE MARK CONSISTS OF STANDARD CHARACTERS WITHOUT CLAIM TO ANY PARTICULAR FONT, STYLE, SIZE, OR COLOR.

FOR EMBROIDERY FLOSS; THREAD (U.S. CL. 43).  
DEIRDRE ROBERTSON, EXAMINING ATTORNEY

SN 77-763,218. KINKARACO - GREEN BURIAL PRODUCTS, SAN FRANCISCO, CA. FILED 6-18-2009.

# VARANASI

THE MARK CONSISTS OF STANDARD CHARACTERS WITHOUT CLAIM TO ANY PARTICULAR FONT, STYLE, SIZE, OR COLOR.

THE WORDING "VARANASI" HAS NO MEANING IN A FOREIGN LANGUAGE.

FOR FUNERAL, BURIAL, AND CREMATION SHROUDS (U.S. CLS. 42 AND 50).  
KATHERINE STOIDES, EXAMINING ATTORNEY

**CLASS 24—FABRICS**

SN 76-705,492. BEST BRANDS CONSUMER PRODUCTS, INC., NEW YORK, NY. FILED 11-26-2010.

# HOME WONDERS

THE MARK CONSISTS OF STANDARD CHARACTERS WITHOUT CLAIM TO ANY PARTICULAR FONT, STYLE, SIZE, OR COLOR.

NO CLAIM IS MADE TO THE EXCLUSIVE RIGHT TO USE "HOME", APART FROM THE MARK AS SHOWN.

FOR DISH CLOTHS, WASH CLOTHS, KITCHEN TOWELS, CLEANING TOWELS, DUSTING TOWELS AND SCRUBBING TOWELS (U.S. CLS. 42 AND 50).

FIRST USE 10-16-2010; IN COMMERCE 10-16-2010.  
ADA HAN, EXAMINING ATTORNEY

SN 85-018,335. JANE BAHK, SAN FRANCISCO, CA. FILED 4-20-2010.

# Snozzzy

THE MARK CONSISTS OF STANDARD CHARACTERS WITHOUT CLAIM TO ANY PARTICULAR FONT, STYLE, SIZE, OR COLOR.

FOR REUSABLE TEXTILE CLOTH ADAPTED TO BE WORN ABOUT AN APPENDAGE OF A USER, NAMELY, A CUSTOMIZED HANDKERCHIEF (U.S. CLS. 42 AND 50).

FRANK LATTUCA, EXAMINING ATTORNEY

**CLASS 24—(Continued).**

SN 85-101,805. JACQUI DANIELS DESIGNS LLC, PHILADELPHIA, PA. FILED 8-6-2010.



THE MARK CONSISTS OF THE STYLIZED TEXT "WRAPSODY".

FOR HAIR WRAPS, NAMELY, FABRIC WITH SOFT WIRE DESIGNED FOR HEAD USE (U.S. CLS. 42 AND 50).

KEVON CHISOLM, EXAMINING ATTORNEY

SN 85-134,312. PB&J DISCOVERIES, LLC, NEWTON, MA. FILED 9-21-2010.

NO CLAIM IS MADE TO THE EXCLUSIVE RIGHT TO USE "CHAIR PROTECTOR", APART FROM THE MARK AS SHOWN.

THE MARK CONSISTS OF THE WORD "SMART" AND "SEAT" WRITTEN TOGETHER IN ALL LOWERCASE LETTERS IN ARIEL FONT WITH A THIN LINE ACROSS THE TOP OF THEM AND THE WORDS "CHAIR" AND "PROTECTOR" IN ALL LOWERCASE LETTERS IN ARIEL FONT BELOW "SMARTSEAT".

FOR UNFITTED FABRIC COVERS TO PROTECT DINING ROOM CHAIRS (U.S. CLS. 42 AND 50).

FIRST USE 8-15-2010; IN COMMERCE 8-15-2010.

LINDA MICKLEBURGH, EXAMINING ATTORNEY

SN 85-153,259. ALJUNDI, JILL R, DBA KIDILLOW, OVERLAND PARK, KS. FILED 10-14-2010.



THE COLOR(S) RED, WHITE, YELLOW, BLUE, GREEN AND BROWN IS/ARE CLAIMED AS A FEATURE OF THE MARK.

THE MARK CONSISTS OF THE WORD "KIDILLOW" WITH THE COLOR RED APPEARING IN THE "K", THE LETTER "I" APPEARING AS A STYLIZED PERSON IN YELLOW, THE COLOR BLUE APPEARS IN THE LETTER "D", THE COLOR GREEN APPEARS IN THE SECOND LETTER "I", THE LETTER "L" APPEARS IN YELLOW, THE SECOND LETTER "L" APPEARS IN RED, THE LETTER "O" APPEARS IN BLUE, AND THE LETTER "W" APPEARS IN GREEN SURROUNDED BY A WHITE AND BROWN DESIGN AROUND THE ENTIRE MARK.

FOR QUILTS (U.S. CLS. 42 AND 50).

FIRST USE 2-26-2010; IN COMMERCE 2-26-2010.

CHARLES L. JENKINS, EXAMINING ATTORNEY

**CLASS 24—(Continued).**

SN 85-153,641. ARTIFACTS INDIA U.S. LLC, ROGERS, AR. FILED 10-15-2010.



THE MARK CONSISTS OF THE WORD "ARTIFACTS" WITH A STYLIZED "S" AND THREE DOTS ABOVE THE IMAGE.

FOR CUSHION COVERS; TABLE LINEN, NAMELY, COASTERS, NAPKINS, PLACEMATS, TABLE CLOTHS NOT OF PAPER, FABRIC TABLE RUNNERS, UNFITTED CHAIR COVERS NOT OF PAPER (U.S. CLS. 42 AND 50).

MELISSA VALLILLO, EXAMINING ATTORNEY

SN 85-159,242. THE PILLOW DOC, PORTSMOUTH, NH. FILED 10-22-2010.

## THE POSTURE DOC

THE MARK CONSISTS OF STANDARD CHARACTERS WITHOUT CLAIM TO ANY PARTICULAR FONT, STYLE, SIZE, OR COLOR.

FOR BED PILLOWS (U.S. CLS. 42 AND 50).

FIRST USE 7-30-2010; IN COMMERCE 9-1-2010.

DANNEAN HETZEL, EXAMINING ATTORNEY

SN 85-160,746. ACL IMPEX, LDA., GUARDIZELA, PORTUGAL, FILED 10-25-2010.

## THE AMÁLIA COLLECTION

THE MARK CONSISTS OF STANDARD CHARACTERS WITHOUT CLAIM TO ANY PARTICULAR FONT, STYLE, SIZE, OR COLOR.

NO CLAIM IS MADE TO THE EXCLUSIVE RIGHT TO USE "COLLECTION", APART FROM THE MARK AS SHOWN.

FOR HOUSEHOLD LINEN, NAMELY, BED COVERS, BED SHEETS, DUVET COVERS, PILLOW CASES, BEDSPREADS; HOUSEHOLD LINEN; BED LINEN; BATH LINEN; BATH TOWELS (U.S. CLS. 42 AND 50).

CHRISTINE MARTIN, EXAMINING ATTORNEY



**CLASS 24—(Continued).**

SN 85-172,412. KILTRONX ENVIRO SYSTEMS, LLC, HAUP-PAUGE, NY. FILED 11-9-2010.

MOTHER EARTH'S OWN BEDBUG  
REMEDY

THE MARK CONSISTS OF STANDARD CHARACTERS WITHOUT CLAIM TO ANY PARTICULAR FONT, STYLE, SIZE, OR COLOR.

NO CLAIM IS MADE TO THE EXCLUSIVE RIGHT TO USE "BEDBUG REMEDY", APART FROM THE MARK AS SHOWN.

FOR TEXTILE AND TEXTILE GOODS, NAMELY, PROTECTIVE COVERS AND CASES FOR PILLOWS, MATTRESSES, BOX SPRINGS, QUILTS, AND PET BEDS (U.S. CLS. 42 AND 50).

LIEF MARTIN, EXAMINING ATTORNEY

**CLASS 24—(Continued).**

SN 85-176,030. RODRICK, GARY, CLEVELAND, OH. FILED 11-12-2010.

Germ-Freak

THE MARK CONSISTS OF STANDARD CHARACTERS WITHOUT CLAIM TO ANY PARTICULAR FONT, STYLE, SIZE, OR COLOR.

FOR BED BLANKETS; BED SHEETS; COMFORTERS; MATTRESS PADS; PILLOW CASES (U.S. CLS. 42 AND 50).

FIRST USE 12-0-2009; IN COMMERCE 10-1-2010.

DOMINIC J. FERRAIUOLO, EXAMINING ATTORNEY

SN 85-172,496. SOFTLINE HOME FASHIONS, INC., GARDENA, CA. FILED 11-9-2010.

ENERGEX

THE MARK CONSISTS OF STANDARD CHARACTERS WITHOUT CLAIM TO ANY PARTICULAR FONT, STYLE, SIZE, OR COLOR.

FOR FABRIC CURTAINS SPECIFICALLY DESIGNED TO BLOCK OUT LIGHT (U.S. CLS. 42 AND 50).

BRIAN PINO, EXAMINING ATTORNEY

SN 85-176,885. MARGIE VAN DIJK BROWN, NORTH HOLLYWOOD, CA. FILED 11-15-2010.

DON'T SWEAT IT

THE MARK CONSISTS OF STANDARD CHARACTERS WITHOUT CLAIM TO ANY PARTICULAR FONT, STYLE, SIZE, OR COLOR.

FOR TOWELS, NAMELY EXERCISE AND WORKOUT TOWELS (U.S. CLS. 42 AND 50).

WON TEAK OH, EXAMINING ATTORNEY

SN 85-174,792. WESTEX INC., CHICAGO, IL. FILED 11-11-2010.

ULTRASOFT AC

THE MARK CONSISTS OF STANDARD CHARACTERS WITHOUT CLAIM TO ANY PARTICULAR FONT, STYLE, SIZE, OR COLOR.

OWNER OF U.S. REG. NO. 2,413,756.  
FOR FLAME-RETARDANT FABRIC FOR USE IN THE MANUFACTURE OF PROTECTIVE CLOTHING (U.S. CLS. 42 AND 50).

FIRST USE 7-13-2010; IN COMMERCE 7-13-2010.

JOHN E. MICHOS, EXAMINING ATTORNEY

SN 85-177,400. PRECISION CUSTOM COATING, LLC, TOWA, NJ. FILED 11-16-2010.

BEDBUGBANISHER

THE MARK CONSISTS OF STANDARD CHARACTERS WITHOUT CLAIM TO ANY PARTICULAR FONT, STYLE, SIZE, OR COLOR.

FOR FABRICS, NAMELY, MATTRESS COVERS, PROTECTORS, AND ENCASEMENTS (U.S. CLS. 42 AND 50).

FIRST USE 11-8-2010; IN COMMERCE 11-8-2010.

SEAN CROWLEY, EXAMINING ATTORNEY

**CLASS 24—(Continued).**

SN 85-177,408. PRECISION CUSTOM COATING, LLC, TOWA, NJ. FILED 11-16-2010.

## SECUREZZZIP

THE MARK CONSISTS OF STANDARD CHARACTERS WITHOUT CLAIM TO ANY PARTICULAR FONT, STYLE, SIZE, OR COLOR.

FOR FABRICS, NAMELY, MATTRESS COVERS, PROTECTORS, AND ENCASEMENTS (U.S. CLS. 42 AND 50).  
FIRST USE 11-8-2010; IN COMMERCE 11-8-2010.  
SEAN CROWLEY, EXAMINING ATTORNEY

---

SN 85-177,515. W. R. RAYSON CO., INC., BURGAW, NC. FILED 11-16-2010.

## RAY-PET

THE MARK CONSISTS OF STANDARD CHARACTERS WITHOUT CLAIM TO ANY PARTICULAR FONT, STYLE, SIZE, OR COLOR.

FOR TOWELS (U.S. CLS. 42 AND 50).  
GRETTA YAO, EXAMINING ATTORNEY

---

SN 85-177,571. T&APRODUCTS LLC, DBA WELL HUNG VINEYARD, CHARLOTTESVILLE, VA. FILED 11-16-2010.

## Well Hung

THE MARK CONSISTS OF STANDARD CHARACTERS WITHOUT CLAIM TO ANY PARTICULAR FONT, STYLE, SIZE, OR COLOR.

OWNER OF U.S. REG. NOS. 3,755,003, 3,911,608 AND 3,914,692.

FOR TOWELS (U.S. CLS. 42 AND 50).  
FIRST USE 6-1-2009; IN COMMERCE 6-1-2009.  
TASNEEM HUSSAIN, EXAMINING ATTORNEY

**CLASS 24—(Continued).**

SN 85-178,221. JAY APPAREL GROUP, NEW YORK, NY. FILED 11-16-2010.

## BATTON

THE MARK CONSISTS OF STANDARD CHARACTERS WITHOUT CLAIM TO ANY PARTICULAR FONT, STYLE, SIZE, OR COLOR.

FOR TEXTILE FABRICS FOR THE MANUFACTURE OF CLOTHING (U.S. CLS. 42 AND 50).  
FIRST USE 11-9-2010; IN COMMERCE 11-9-2010.  
BRENDAN REGAN, EXAMINING ATTORNEY

**CLASS 25—CLOTHING**

SN 76-703,231. HUANG, QIAORAN, NEW YORK, NY. FILED 6-3-2010.

## BABYGHOST BY QIAORAN

THE MARK CONSISTS OF STANDARD CHARACTERS WITHOUT CLAIM TO ANY PARTICULAR FONT, STYLE, SIZE, OR COLOR.

THE NAME "QIAORAN" IDENTIFIES A LIVING INDIVIDUAL WHOSE CONSENT IS OF RECORD.

THE ENGLISH TRANSLATION OF "QIAORAN" IN THE MARK IS "QUIETLY".

FOR CLOTHING AND WOMEN'S CLOTHING, NAMELY, SHIRTS, TOPS, BOTTOMS, BLOUSES, SKIRTS, COAT, PANTS; ACCESSORIES, NAMELY, HATS, SCARVES, BELTS, LEG WARMERS; KNITWEAR, NAMELY, KNIT SHIRT, KNIT PANTS, KNIT JACKETS; UNDERWEAR; GLOVES; SCARVES; SHIRTS; COATS; TROUSERS; BLOUSES; JACKETS; SUITS (U.S. CLS. 22 AND 39).

MYRIAH HABEEB, EXAMINING ATTORNEY

**CLASS 25—(Continued).**

SN 76-703,232. HUANG, QIAORAN, NEW YORK, NY. FILED 6-3-2010.

# QIAORAN

THE MARK CONSISTS OF STANDARD CHARACTERS WITHOUT CLAIM TO ANY PARTICULAR FONT, STYLE, SIZE, OR COLOR.

THE NAME "QIAORAN" IDENTIFIES A LIVING INDIVIDUAL WHOSE CONSENT IS OF RECORD.

THE ENGLISH TRANSLATION OF "QIAORAN" IN THE MARK IS "QUIETLY".

FOR CLOTHING AND WOMEN'S CLOTHING, NAMELY, SHIRTS, TOPS, BOTTOMS, BLOUSES, SKIRTS, COAT, PANTS; ACCESSORIES, NAMELY, HATS, SCARVES, BELTS, LEG WARMERS; KNITWEAR, NAMELY, KNIT SHIRTS, KNIT PANTS, KNIT JACKETS; UNDERWEAR; GLOVES; SCARVES; SHIRTS; COATS; TROUSERS; BLOUSES; JACKETS; SUITS (U.S. CLS. 22 AND 39).

MYRIAH HABEEB, EXAMINING ATTORNEY

**CLASS 25—(Continued).**

SN 76-705,183. SHAW, JEREMY RYAN, DBA HXC FOR LIFE, SPRING, TX. FILED 11-1-2010.

# HXC

THE MARK CONSISTS OF STANDARD CHARACTERS WITHOUT CLAIM TO ANY PARTICULAR FONT, STYLE, SIZE, OR COLOR.

FOR SHORT-SLEEVED OR LONG SLEEVED T-SHIRTS, HATS, UNDERWEAR, SWEATERS, SWEAT PANTS, JEANS, GLOVES, JACKETS, VESTS, AND BANDANAS (U.S. CLS. 22 AND 39).

LINDA ORNDORFF, EXAMINING ATTORNEY

SN 76-703,880. KINGI, ALEX N., DBA THIN LOJIC, SANTA MONICA, CA. FILED 7-23-2010.

# THIN LOJIC

THE MARK CONSISTS OF STANDARD CHARACTERS WITHOUT CLAIM TO ANY PARTICULAR FONT, STYLE, SIZE, OR COLOR.

FOR CLOTHING, NAMELY, SHIRTS (U.S. CLS. 22 AND 39).

FIRST USE 11-0-2008; IN COMMERCE 3-0-2009.  
STEVEN JACKSON, EXAMINING ATTORNEY

SN 77-456,331. MARTINEZ, AARON J., TEMPE, AZ. FILED 4-23-2008.



THE MARK CONSISTS OF THE CONVERGED STYLIZED LETTERS "D" AND "S" WITH THE LETTER "S" APPEARING BACKWARDS; UNDERNEATH OF THE LETTERS IS THE STYLIZED WORDING "DARKSYDE", WITH A BACKWARDS LETTER "S", FOLLOWED BY AN ELLIPSIS.

FOR A-SHIRTS; BANDANAS; BEANIES; DRESS SHIRTS; HALLOWEEN COSTUMES; HEAD WEAR; HOODED PULLOVERS; HOODED SWEAT SHIRTS; JACKETS; KNIT SHIRTS; LONG-SLEEVED SHIRTS; POLO SHIRTS; SHIRTS; SHOES; SHORT-SLEEVED OR LONG-SLEEVED T-SHIRTS; SHORT-SLEEVED SHIRTS; SHORTS; T-SHIRTS; TANK TOPS; THONGS; TIES (U.S. CLS. 22 AND 39).

MICHAEL LITZAU, EXAMINING ATTORNEY

SN 76-704,832. SMITH, MARK J., KANSAS CITY, MO. FILED 10-12-2010.



THE MARK IS PRESENTED AS TWO DOG TAGS ON A CHAIN WITH 8 SOLDIERS, SEVEN OF THEM CARRYING FLAGS.

FOR T-SHIRTS (U.S. CLS. 22 AND 39).  
FIRST USE 9-15-2010; IN COMMERCE 9-16-2010.  
GINA FINK, EXAMINING ATTORNEY

**CLASS 25—(Continued).**

SN 77-518,804. TRASVINA, ALEX, CHULA VISTA, CA. FILED 7-10-2008.



THE MARK CONSISTS OF THE WORDING "FUERZA" WITH A CROSS WITH A RING ATTACHED TO THE BOTTOM, TEN SMALL CIRCLES EVENLY SPACED ALONG THE OUTSIDE OF THE RING AND THE STYLIZED LETTER "F" IN THE CENTER OF THE RING.

THE FOREIGN WORDING IN THE MARK TRANSLATES INTO ENGLISH AS STRENGTH, POWER, AND WILL.

FOR CLOTHING, NAMELY, T SHIRTS, LONG SLEEVE SHIRTS, HATS, SWEAT SHIRTS, THERMAL SHIRTS (U.S. CLS. 22 AND 39).

BILL DAWE, EXAMINING ATTORNEY

SN 77-521,933. THIGPEN, KATHRYN LAWRENCE, CHARLOTTE, NC. FILED 7-14-2008.

**FLINGZ**

THE MARK CONSISTS OF STANDARD CHARACTERS WITHOUT CLAIM TO ANY PARTICULAR FONT, STYLE, SIZE, OR COLOR.

OWNER OF U.S. REG. NO. 3,280,377.

FOR LADIES' UNDERWEAR (U.S. CLS. 22 AND 39).

FIRST USE 9-15-2007; IN COMMERCE 9-15-2007.

BRIAN PINO, EXAMINING ATTORNEY

SN 77-644,854. BALLY, JEFF, LAGUNA HILLS, CA. FILED 1-7-2009.



THE MARK CONSISTS OF THE WORDING "PROVING GROUND" AND "ESTABLISH THE TRUTH, PUT YOURSELF TO THE TEST" IN STYLIZED FONT TO THE LEFT OF WHICH IS A DESIGN OF A WAVE AND A SKULL.

FOR CLOTHING, NAMELY, SHIRTS, T-SHIRTS, SWEATSHIRTS, JACKETS, SHORTS, CAPS, HATS, WETSUITS, SWIMWEAR (U.S. CLS. 22 AND 39).

DAVID HOFFMAN, EXAMINING ATTORNEY

**CLASS 25—(Continued).**

SN 77-655,731. ORIENTAL RESOURCES INTERNATIONAL, LLC, TORRANCE, CA. FILED 1-23-2009.



THE COLOR(S) BLUE, GRAY, RED AND WHITE IS/ARE CLAIMED AS A FEATURE OF THE MARK.

THE MARK CONSISTS OF THE WORDING "PLATINUM CLUB" WITH THE WORD "PLATINUM" IN GRAY AND APPEARING ABOVE THE WORD "CLUB", WHICH IS IN RED. A FIVE-POINTED STAR IN GRAY, APPEARS TO THE RIGHT OF THE WORD "PLATINUM". THE WORDING AND THE STAR DESIGN ARE SURROUNDED BY A BLUE RECTANGLE, WHICH IS ITSELF SURROUNDED BY BORDER OF WHITE AND BLUE.

FOR CASUAL WEAR, NAMELY, SHORTS, T-SHIRTS, PANTS, TRACK SUITS, SWEAT PANTS, JACKETS, DRESSES, JEANS, COATS, SHEEPSKIN COATS, SKIRTS, JUMPERS AND PULLOVERS, TUNICS, SMOCKS, GOWNS, SWIMSUITS, SWIMWEAR, AND SOCKS (U.S. CLS. 22 AND 39).

ANDREA HACK, EXAMINING ATTORNEY

SN 77-670,371. SPOILED ROTTEN U.S.A., INC., BRONX, NY. FILED 2-13-2009.



OWNER OF U.S. REG. NO. 3,398,862.

THE MARK CONSISTS OF THE WORDS "SPOILED ROTTEN" UNDERLINED AND ABOVE THE STYLIZED LETTERS OF "U.S.A." WITH AN IMAGE OF AN UPSIDE DOWN TRIANGLE BEHIND.

SEC. 2(F) AS TO "SPOILED ROTTEN U.S.A.".

FOR WOMEN AND CHILDREN'S SPORTSWEAR AND APPAREL, NAMELY, SHORTS, PANTS, SHIRTS, AND JACKETS (U.S. CLS. 22 AND 39).

FIRST USE 5-0-1986; IN COMMERCE 5-0-1986.

SALLY SHIH, EXAMINING ATTORNEY

**CLASS 25—(Continued).**

SN 77-811,342. TRIUMPH INTERNATIONAL, INC., ATLANTA, GA. FILED 8-24-2009.

NEVERLAND VALLEY RANCH

THE MARK CONSISTS OF STANDARD CHARACTERS WITHOUT CLAIM TO ANY PARTICULAR FONT, STYLE, SIZE, OR COLOR.

FOR CLOTHING, NAMELY, SHIRTS, JACKETS, SWEATERS, PANTS, BELTS, SOCKS, SWEATSHIRTS, JERSEYS, SHORTS, JOGGING SUITS, SWEAT PANTS; HEADWEAR; SCARVES, GLOVES, COATS, HOSIERY, NECKTIES, RAINWEAR, SWIMWEAR, SLEEPWEAR, ROBES, THERMAL UNDERWEAR, HEADBANDS, AND WRISTBANDS; FOOTWEAR; COSTUMES FOR USE IN CHILDREN'S DRESS UP PLAY; COSTUMES FOR USE IN ROLE-PLAYING GAMES; DANCE SHOES; DANCE COSTUMES; MASQUERADE COSTUMES AND MASKS SOLD IN CONNECTION THEREWITH; NOVELTY HEADWEAR WITH ATTACHED WIGS; INFANT WEAR; INFANTS' SHOES AND BOOTS (U.S. CLS. 22 AND 39).

HEATHER THOMPSON, EXAMINING ATTORNEY

SN 77-848,671. COSWAY (M) SDN. BHD., 50200 KUALA LUMPUR, MALAYSIA. FILED 10-14-2009.



OWNER OF MALAYSIA REG. NO. 06020620, DATED 11-13-2006, EXPIRES 11-13-2016.

THE COLOR(S) GREY IS/ARE CLAIMED AS A FEATURE OF THE MARK.

THE MARK CONSISTS OF THE GREY STYLIZED WORDING "AMBRACE" UNDERLINED IN THE COLOR GREY.

FOR BODICES; LINGERIE; UNDERCLOTHING, NAMELY, CORSETS, GIRDLES, AND UNDERGARMENTS, RE-SHAPING INNERWEAR, NAMELY, BODY SHAPING BRA, WAIST SHAPING CORSET, BODY SHAPING CORSET AND BODY SHAPING GIRDLE; T-SHIRTS; SLEEPWEAR (U.S. CLS. 22 AND 39).

AMEEN IMAM, EXAMINING ATTORNEY

**CLASS 25—(Continued).**

SN 77-859,789. TERRY M. CARDENAS, ARLINGTON, TX. FILED 10-28-2009.

Ol' America

THE MARK CONSISTS OF STANDARD CHARACTERS WITHOUT CLAIM TO ANY PARTICULAR FONT, STYLE, SIZE, OR COLOR.

NO CLAIM IS MADE TO THE EXCLUSIVE RIGHT TO USE "AMERICA", APART FROM THE MARK AS SHOWN.

FOR APRONS; ATHLETIC APPAREL, NAMELY, SHIRTS, PANTS, JACKETS, FOOTWEAR, HATS AND CAPS, ATHLETIC UNIFORMS; BANDANAS; BASEBALL CAPS; BODY SHIRTS; CAMP SHIRTS; CAP VISORS; CAPRI PANTS; CAPS; CARGO PANTS; CLOTHING FOR ATHLETIC USE, NAMELY, PADDED SHIRTS; DENIMS; DRESS SHIRTS; FISHING SHIRTS; GLOVES; GLOVES AS CLOTHING; GOLF CAPS; GOLF PANTS, SHIRTS AND SKIRTS; GOLF SHIRTS; HATS FOR INFANTS, BABIES, TODDLERS AND CHILDREN; HOODED SWEAT SHIRTS; HUNTING SHIRTS; JOGGING PANTS; KNIT SHIRTS; LONG-SLEEVED SHIRTS; MOISTURE-WICKING SPORTS SHIRTS; NIGHT SHIRTS; OPEN-NECKED SHIRTS; OVER SHIRTS; PIQUE SHIRTS; POLO SHIRTS; RUGBY SHIRTS; SCIENTIFIC AND TECHNOLOGICAL APPAREL, NAMELY, SHIRTS, PANTS, JACKETS, FOOTWEAR, HATS AND CAPS, UNIFORMS; SHIRT FRONTS; SHIRT YOKES; SHIRTS; SHIRTS AND SHORT-SLEEVED SHIRTS; SHIRTS FOR INFANTS, BABIES, TODDLERS AND CHILDREN; SHIRTS FOR SUITS; SHORT-SLEEVED OR LONG-SLEEVED T-SHIRTS; SHORT-SLEEVED SHIRTS; SKIRT SUITS; SKIRTS AND DRESSES; SKULL CAPS; SLEEP SHIRTS; SPORT SHIRTS; SPORTS SHIRTS WITH SHORT SLEEVES; SWEAT SHIRTS; T-SHIRTS; TEE SHIRTS; TURTLE NECK SHIRTS; WIND SHIRTS; YOGA SHIRTS (U.S. CLS. 22 AND 39).

KIM MONINGHOFF, EXAMINING ATTORNEY

SN 77-893,362. YANG ZHANG, ARCADIA, CA. FILED 12-15-2009.

ZOE COUTURE

THE MARK CONSISTS OF STANDARD CHARACTERS WITHOUT CLAIM TO ANY PARTICULAR FONT, STYLE, SIZE, OR COLOR.

NO CLAIM IS MADE TO THE EXCLUSIVE RIGHT TO USE "COUTURE", APART FROM THE MARK AS SHOWN. FOR SWEATERS (U.S. CLS. 22 AND 39).

CYNTHIA TRIPI, EXAMINING ATTORNEY

**CLASS 25—(Continued).**

SN 77-925,821. BROWN SHOE COMPANY, INC., ST. LOUIS, MO. FILED 2-2-2010.

# NAYA

THE MARK CONSISTS OF STANDARD CHARACTERS WITHOUT CLAIM TO ANY PARTICULAR FONT, STYLE, SIZE, OR COLOR.

FOR CLOTHING, NAMELY, JACKETS, PANTS, SHIRTS, SHORTS, SKIRTS, DRESSES; CLOTHING ACCESSORIES, NAMELY, SCARVES, SOCKS, HOSIERY AND LEGGINGS; BELTS (U.S. CLS. 22 AND 39).

CHRISTINE MARTIN, EXAMINING ATTORNEY

SN 77-927,276. FAME JEANS INC., ST. LAURENT, QUEBEC, CANADA, FILED 2-3-2010.

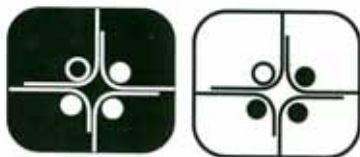

total  
control

PRIORITY CLAIMED UNDER SEC. 44(D) ON CANADA APPLICATION NO. 1468026, FILED 2-2-2010, REG. NO. TMA788,848, DATED 1-27-2011, EXPIRES 1-27-2026.

THE MARK CONSISTS OF A SHADED SQUARE WITH FOUR CIRCLES INSIDE, THREE OF WHICH ARE SOLID AND THE OTHER IN OUTLINE, INSIDE FOUR LINES FORMING RIGHT ANGLES FACING THE MIDDLE OF THE SQUARE, WITH AN IDENTICAL NON-SHADED SQUARE WITH FOUR SHADED CIRCLES INSIDE, THREE OF WHICH ARE SOLID AND THE OTHER IN OUTLINE, INSIDE FOUR SHADED LINES FORMING RIGHT ANGLES FACING THE MIDDLE OF THE SQUARE TO THE RIGHT OF THE SHADED SQUARE, AND THE WORDING "TOTAL CONTROL" IN STYLIZED LETTERS UNDERNEATH THE SQUARES.

FOR LADIES CLOTHING, NAMELY, PANTS AND TOPS (U.S. CLS. 22 AND 39).

NICHOLAS COLEMAN, EXAMINING ATTORNEY

SN 77-941,939. TIARA, INC., DBA BABEE GREENS, ASHEVILLE, NC. FILED 2-22-2010.

# Babee Greens

THE MARK CONSISTS OF STANDARD CHARACTERS WITHOUT CLAIM TO ANY PARTICULAR FONT, STYLE, SIZE, OR COLOR.

FOR CLOTH DIAPERS; INFANT CLOTH DIAPERS; INFANT DIAPER COVERS (U.S. CLS. 22 AND 39).

B. PARADEWELAI, EXAMINING ATTORNEY

**CLASS 25—(Continued).**

SN 77-943,036. RECOGNITION CLOTHING LIMITED, HAMILTON, BERMUDA, FILED 2-23-2010.

# HONEYSUCKLE

THE MARK CONSISTS OF STANDARD CHARACTERS WITHOUT CLAIM TO ANY PARTICULAR FONT, STYLE, SIZE, OR COLOR.

OWNER OF UNITED KINGDOM REG. NO. 2398946, DATED 9-8-2006, EXPIRES 8-10-2015.

FOR ARTICLES OF CLOTHING, NAMELY, T-SHIRTS, SHIRTS, SWEATERS, CARDIGANS, JACKETS, COATS, SHAWLS, TROUSERS, PANTS, SHORTS, DUNGAREES, LEGGINGS, SKIRTS, DRESSES, JUMPERS, GALOSHES, BLOUSES, SWEATSHIRTS, WAISTCOATS, JERSEYS, NIGHTSHIRTS, PAJAMAS, FLEECE TOPS, JEANS, ANORAKS, SMOCKS, SALOPETTES, CAGOULES, VESTS, UNDERSHIRTS, RAINWEAR, PARKAS, BLAZERS, HOODED TOPS, KNIT TOPS, HALTER TOPS, TANK TOPS, BODYSUITS AND SINGLETS; ARTICLES OF SPORTS CLOTHING, NAMELY, RUNNING SHORTS AND TRACKSUITS; FOOTWEAR; CAPS AND HATS; BELTS; SCARVES; SOCKS; HOSIERY AND LINGERIE; BEACHWEAR; SWIMWEAR; BATHROBES; BATHING ROBES; NIGHTWEAR (U.S. CLS. 22 AND 39).

KELLY BOULTON, EXAMINING ATTORNEY

SN 77-956,702. STEPHEN T. PYLES, OCALA, FL. FILED 3-11-2010.

# TRAP DOOR

THE MARK CONSISTS OF STANDARD CHARACTERS WITHOUT CLAIM TO ANY PARTICULAR FONT, STYLE, SIZE, OR COLOR.

FOR CLOTHING, NAMELY, T-SHIRTS, SHIRTS, SWEATSHIRTS, COATS, JACKETS, PANTS, AND HATS (U.S. CLS. 22 AND 39).

LINDA ESTRADA, EXAMINING ATTORNEY

SN 77-956,740. STEPHEN T. PYLES, OCALA, FL. FILED 3-11-2010.

# FREAK MAGNET

THE MARK CONSISTS OF STANDARD CHARACTERS WITHOUT CLAIM TO ANY PARTICULAR FONT, STYLE, SIZE, OR COLOR.

FOR CLOTHING, NAMELY, T-SHIRTS, SHIRTS, SWEATSHIRTS, COATS, JACKETS, PANTS, AND HATS (U.S. CLS. 22 AND 39).

LINDA ESTRADA, EXAMINING ATTORNEY

**CLASS 25—(Continued).**

SN 77-957,250. THOMPSON, ALLISON, MISSION VIEJO, CA.  
FILED 3-12-2010.

# NOT HERE CREW

THE MARK CONSISTS OF STANDARD CHARACTERS WITHOUT CLAIM TO ANY PARTICULAR FONT, STYLE, SIZE, OR COLOR.

FOR CLOTHING, NAMELY, T-SHIRTS, JACKETS, PANTS, AND HEADWEAR (U.S. CLS. 22 AND 39).  
JOHN SCHUYLER YARD, EXAMINING ATTORNEY

SN 78-705,602. DIFERDINANDO, DANIELLE, ELLICOTT CITY, MD. FILED 9-1-2005.



THE MARK CONSISTS OF A STYLIZED "D" BENEATH A CROWN AND A PAIR OF LION LIKE FIGURES OPPOSITELY LOCATED FACING THE CROWN AND THE LETTER "D" ALL ABOVE THE WORDS "SAVVY" "SLEEK" "SOPHISTICATED".

FOR TIES (U.S. CLS. 22 AND 39).  
FIRST USE 4-24-2005; IN COMMERCE 4-24-2005.  
JASON TURNER, EXAMINING ATTORNEY

SN 78-964,628. TAKE-TWO INTERACTIVE SOFTWARE, INC., NEW YORK, NY. FILED 8-31-2006.

# BULLY

THE MARK CONSISTS OF STANDARD CHARACTERS WITHOUT CLAIM TO ANY PARTICULAR FONT, STYLE, SIZE, OR COLOR.

FOR CLOTHING, NAMELY, SHIRTS, T-SHIRTS, SWEATSHIRTS, CASUAL AND LEISURE JACKETS; HEADGEAR, NAMELY, HATS AND CAPS; FOOTWEAR (U.S. CLS. 22 AND 39).  
JAMES MACFARLANE, EXAMINING ATTORNEY

**CLASS 25—(Continued).**

SN 79-039,316. AP HOLDING B.V., NETHERLANDS, FILED 4-19-2007.

# A1A

THE MARK CONSISTS OF STANDARD CHARACTERS WITHOUT CLAIM TO ANY PARTICULAR FONT, STYLE, SIZE, OR COLOR.

OWNER OF INTERNATIONAL REGISTRATION 0926198 DATED 4-19-2007, EXPIRES 4-19-2017.

FOR CLOTHING, NAMELY, SWEATSHIRTS, SHIRTS, T-SHIRTS, SWEATERS, PULLOVERS, GILETS, WAIST-COATS, JACKETS, PANTS, SHOES, HEADGEAR, NAMELY, CAPS (U.S. CLS. 22 AND 39).

CHERYL CLAYTON, EXAMINING ATTORNEY

SN 79-081,857. PINGHU YUECHUN SWEATER CO., LTD., ZHEJIANG, CHINA, FILED 4-13-2010.



OWNER OF INTERNATIONAL REGISTRATION 1036741 DATED 4-13-2010, EXPIRES 4-13-2020.

THE WORDING "ELATR" HAS NO MEANING IN A FOREIGN LANGUAGE.

FOR LAYETTES; BATHING SUITS; FOOTBALL SHOES; SHOES; HATS; SOCKS; GLOVES; NECKTIES; LEATHER BELTS FOR CLOTHING (U.S. CLS. 22 AND 39).

ADA HAN, EXAMINING ATTORNEY

SN 79-085,826. GOLDEN LADY COMPANY S.P.A., ITALY, FILED 3-18-2010.

# GOLDEN LADY

THE MARK CONSISTS OF STANDARD CHARACTERS WITHOUT CLAIM TO ANY PARTICULAR FONT, STYLE, SIZE, OR COLOR.

OWNER OF INTERNATIONAL REGISTRATION 0548028 DATED 2-14-1990, EXPIRES 2-14-2020.

OWNER OF U.S. REG. NO. 1,534,401.

NO CLAIM IS MADE TO THE EXCLUSIVE RIGHT TO USE "LADY", APART FROM THE MARK AS SHOWN.

FOR STOCKINGS, SOCKS, TIGHTS, PANTYHOSES, DRESSING GOWNS, BOXERS, SINGLETs, VESTS, INTIMATE VESTS, TOPS, SLIPS, PANTIES, MINI BRIEFS, BRAS, SUSPENDER-BELTS, CORSETS; BEACH WEAR, NAMELY, BATHING SUITS, SUN SUITS, BEACH JACKETS, BEACH PANTS, BEACH DRESSES, PAREOS AND BATHING GOWNS (U.S. CLS. 22 AND 39).

TASNEEM HUSSAIN, EXAMINING ATTORNEY

**CLASS 25—(Continued).**

SN 85-007,015. SONNY PRODUCTIONS, LLC, SUMMERFIELD, NC. FILED 4-6-2010.

**MYRTLE BEACH BIKE WEEK WEST**

THE MARK CONSISTS OF STANDARD CHARACTERS WITHOUT CLAIM TO ANY PARTICULAR FONT, STYLE, SIZE, OR COLOR.

OWNER OF U.S. REG. NOS. 3,099,481 AND 3,334,097.

NO CLAIM IS MADE TO THE EXCLUSIVE RIGHT TO USE "MYRTLE BEACH BIKE" AND "WEST", APART FROM THE MARK AS SHOWN.

FOR APPAREL, NAMELY, COATS, SHIRTS, T-SHIRTS, SWEAT SHIRTS, PANTS, SWEAT PANTS, CHAPS, VESTS, TANK TOPS, CAPS AND BANDANAS (U.S. CLS. 22 AND 39).

EVELYN BRADLEY, EXAMINING ATTORNEY

SN 85-009,737. HANSEN & PEDERSEN I/S, AALBORG SV, DENMARK, FILED 4-8-2010.

**Shine Fashion**

THE MARK CONSISTS OF STANDARD CHARACTERS WITHOUT CLAIM TO ANY PARTICULAR FONT, STYLE, SIZE, OR COLOR.

NO CLAIM IS MADE TO THE EXCLUSIVE RIGHT TO USE "FASHION", APART FROM THE MARK AS SHOWN.

FOR BELTS; GLOVES; JEANS; LEATHER JACKETS; LEATHER PANTS; PANTS; PULLOVERS; SCARVES; SHIRTS; SHOES; SHORTS; SUITS; T-SHIRTS; TIES; UNDERWEAR; WINDCHEATERS (U.S. CLS. 22 AND 39).

KATHERINE M. DUBRAY, EXAMINING ATTORNEY

SN 85-011,074. LEONARD, LORRI, BIG SKY, MT. FILED 4-10-2010.

**REJUJU**

THE MARK CONSISTS OF STANDARD CHARACTERS WITHOUT CLAIM TO ANY PARTICULAR FONT, STYLE, SIZE, OR COLOR.

FOR CLOTHING PRODUCTS, NAMELY, SKIRTS, BOXER BRIEFS, BOXER SHORTS, TOPS, AND ATHLETIC HATS FOR CONSUMERS (U.S. CLS. 22 AND 39).

GINA HAYES, EXAMINING ATTORNEY

**CLASS 25—(Continued).**

SN 85-011,187. BANDELE, KAI A., DBA THE PRINCE PALACE, CHICAGO, IL. FILED 4-10-2010.



THE COLOR(S) BABY BLUE, NAVY BLUE, LIME GREEN, SILVER, GRAY, BLACK AND WHITE IS/ARE CLAIMED AS A FEATURE OF THE MARK.

THE MARK CONSISTS OF A FRONT FACING AND BACKWARD FACING LETTER "P" SHADED IN LIME GREEN OUTLINED IN BABY BLUE AND GRAY SHADING, THE STYLIZED WORDS "THE PRINCE PALACE", WHEREIN THE WORDS "THE PRINCE" APPEAR IN BABY BLUE OUTLINED IN NAVY BLUE AND "PALACE" APPEARS IN NAVY BLUE EACH DROP SHADED IN GRAY, AND THE DESIGN OF A SILVER, BLACK AND WHITE CROWN WITHIN THE LETTER "P".

FOR CHILDREN'S CLOTHING, NAMELY, PANTS, SHORTS, SHIRTS, SWEATERS, SWEAT SHIRTS, VESTS, JACKETS, SWIMWEAR, HEADWEAR, SOCKS, UNDERWEAR, SLEEPWEAR, SCARVES, COATS, GLOVES, FOOTWEAR, CLOTHING BELTS AND HOLIDAY COSTUMES (U.S. CLS. 22 AND 39).

FIRST USE 4-8-2010; IN COMMERCE 4-8-2010.  
HANNO RITTNER, EXAMINING ATTORNEY

SN 85-011,255. MARY C. BENNETT, STERLING, IL. FILED S.R. 4-11-2010; AM. P.R. 1-20-2011.



THE NAME(S), PORTRAIT(S), AND/OR SIGNATURE(S) SHOWN IN THE MARK DOES NOT IDENTIFY A PARTICULAR LIVING INDIVIDUAL.

THE MARK CONSISTS OF THE WORDS "WILLIAM MICHAEL".

FOR DRESS SHIRTS (U.S. CLS. 22 AND 39).  
FIRST USE 4-1-2010; IN COMMERCE 4-1-2010.  
RONALD AIKENS, EXAMINING ATTORNEY



**CLASS 25—(Continued).**

SN 85-016,002. LIZ LOGIE, LLC, NEW CANAAN, CT. FILED 4-16-2010.

# LIZETTE

THE MARK CONSISTS OF STANDARD CHARACTERS WITHOUT CLAIM TO ANY PARTICULAR FONT, STYLE, SIZE, OR COLOR.

FOR WOMEN'S BLOUSES AND CLOTHING TOPS IN THE CONTEMPORARY BRIDGE CATEGORY (U.S. CLS. 22 AND 39).

KATHERINE CONNOLLY, EXAMINING ATTORNEY

SN 85-016,458. FORRESTER, SHARNAE, EAST ELMHURST, NY. FILED 4-17-2010.

# NAERO

THE MARK CONSISTS OF STANDARD CHARACTERS WITHOUT CLAIM TO ANY PARTICULAR FONT, STYLE, SIZE, OR COLOR.

THE NAME(S), PORTRAIT(S), AND/OR SIGNATURE(S) SHOWN IN THE MARK IDENTIFIES SHARNAE FORRESTER, WHOSE CONSENT(S) TO REGISTER IS MADE OF RECORD.

FOR COATS; DRESSES; FOOTWEAR; HEADWEAR; JACKETS; PANTS; SHIRTS; SUITS; SWEATERS (U.S. CLS. 22 AND 39).

MICHELE SWAIN, EXAMINING ATTORNEY

SN 85-017,241. MRW HOLDINGS, LLC, LOS ANGELES, CA. FILED 4-19-2010.

# MIKE ROWE GEAR

THE MARK CONSISTS OF STANDARD CHARACTERS WITHOUT CLAIM TO ANY PARTICULAR FONT, STYLE, SIZE, OR COLOR.

OWNER OF U.S. REG. NOS. 3,682,266 AND 3,682,267.

NO CLAIM IS MADE TO THE EXCLUSIVE RIGHT TO USE "GEAR", APART FROM THE MARK AS SHOWN.

THE NAME(S), PORTRAIT(S), AND/OR SIGNATURE(S) SHOWN IN THE MARK IDENTIFIES "MIKE ROWE", WHOSE CONSENT(S) TO REGISTER IS MADE OF RECORD.

FOR CLOTHING, NAMELY, T-SHIRTS, SHIRTS, UNDERSHIRTS, HENLEY SHIRTS, HOODED SWEATSHIRTS, LOUNGEWEAR, JEANS, PANTS, SHORTS, VESTS, OVERALLS, SOCKS, BOOTS, SHOES, HATS, GLOVES, BELTS, HEADWEAR, FOOTWEAR, UNDERWEAR; OUTERWEAR, NAMELY, COATS, JACKETS; SWEATERS, SWEATSHIRTS, SWEATPANTS AND COVERALLS, RAIN SLICKERS, RAINCOATS, SCARVES, APRONS (U.S. CLS. 22 AND 39).

LINDSEY RUBIN, EXAMINING ATTORNEY

**CLASS 25—(Continued).**

SN 85-017,249. MRW HOLDINGS, LLC, LOS ANGELES, CA. FILED 4-19-2010.



OWNER OF U.S. REG. NOS. 3,682,266 AND 3,682,267. NO CLAIM IS MADE TO THE EXCLUSIVE RIGHT TO USE "GEAR", APART FROM THE MARK AS SHOWN.

THE NAME(S), PORTRAIT(S), AND/OR SIGNATURE(S) SHOWN IN THE MARK IDENTIFIES "MIKE ROWE", WHOSE CONSENT(S) TO REGISTER IS MADE OF RECORD.

THE MARK CONSISTS OF A GEAR WITH THE WORD "MIKE" WRITTEN ACROSS THE TOP PORTION OF THE GEAR WITH THE WORD "ROWE" WRITTEN ACROSS THE LOWER PORTION OF THE GEAR AND A CROSSBAR RUNNING HORIZONTALLY ACROSS THE GEAR WITH THE WORD "GEAR" WRITTEN ACROSS THE CROSSBAR AND FOUR SCREWS DEPICTED ON EACH CORNER OF THE CROSSBAR.

FOR CLOTHING, NAMELY, T-SHIRTS, SHIRTS, UNDERSHIRTS, HENLEY SHIRTS, HOODED SWEATSHIRTS, LOUNGEWEAR, JEANS, PANTS, SHORTS, VESTS, OVERALLS, SOCKS, BOOTS, SHOES, HATS, GLOVES, BELTS, HEADWEAR, FOOTWEAR, UNDERWEAR; OUTERWEAR, NAMELY, COATS, JACKETS; SWEATERS, SWEATSHIRTS, SWEATPANTS AND COVERALLS, RAIN SLICKERS, RAINCOATS, SCARVES, APRONS (U.S. CLS. 22 AND 39).

LINDSEY RUBIN, EXAMINING ATTORNEY

SN 85-017,823. UPDIKE, JOHN, LAKE PLACID, FL. FILED 4-20-2010.

# FARM LIFE

THE MARK CONSISTS OF STANDARD CHARACTERS WITHOUT CLAIM TO ANY PARTICULAR FONT, STYLE, SIZE, OR COLOR.

FOR CLOTHING, NAMELY, T-SHIRTS, TOPS, BOTTOMS, PANTS, HEADWEAR, FOOTWEAR (U.S. CLS. 22 AND 39).

ANNE E. GUSTASON, EXAMINING ATTORNEY

**CLASS 25—(Continued).**

SN 85-018,523. OLIBERTE LIMITED, OAKVILLE, ONTARIO, CANADA, FILED 4-20-2010.

# This is Africa

THE MARK CONSISTS OF STANDARD CHARACTERS WITHOUT CLAIM TO ANY PARTICULAR FONT, STYLE, SIZE, OR COLOR.

NO CLAIM IS MADE TO THE EXCLUSIVE RIGHT TO USE "AFRICA", APART FROM THE MARK AS SHOWN.

FOR (BASED ON USE IN COMMERCE) ATHLETIC APPAREL, NAMELY, SHIRTS, PANTS, JACKETS, FOOTWEAR, HATS AND CAPS, ATHLETIC UNIFORMS; ATHLETIC FOOTWEAR; BEACH FOOTWEAR; FLIP FLOPS; FOOTWEAR; FOOTWEAR; FOOTWEAR FOR MEN; FOOTWEAR FOR MEN AND WOMEN; FOOTWEAR FOR WOMEN; FOOTWEAR NOT FOR SPORTS; FOOTWEAR, NAMELY, WORK BOOTS(BASED ON INTENT TO USE) ANKLE BOOTS; ANKLE SOCKS; ANKLETS; AQUA SHOES; ATHLETIC SHOES; ATHLETIC UNIFORMS; BANDANAS; BASEBALL CAPS; BASEBALL CAPS AND HATS; BASEBALL SHOES; BASEBALL UNIFORMS; BEACH SHOES; BEANIES; BELTS; BELTS FOR CLOTHING; BELTS MADE FROM IMITATION LEATHER; BELTS MADE OF LEATHER; BELTS MADE OUT OF CLOTH; BELTS OF TEXTILE; BERETS; BERMUDA SHORTS; BOARD SHORTS; BOAT SHOES; BOOTS; BOOTS FOR MOTORCYCLING; BOOTS FOR SPORT; BOWLING SHOES; BOXER BRIEFS; BOXER SHORTS; BOXING SHOES; BOXING SHORTS; BRIEFS; BRIEFS; BUCKET CAPS; CANVAS SHOES; CAP PEAKS; CAP VISORS; CAPS; CAPS WITH VISORS; CARGO PANTS; CHILDREN'S AND INFANT'S APPAREL, NAMELY, JUMPERS, OVERALL SLEEPWEAR, PAJAMAS, ROMPERS AND ONE-PIECE GARMENTS; CHILDREN'S AND INFANTS' CLOTH BIBS; CHILDREN'S CLOTH EATING BIBS; CHILDREN'S HEADWEAR; CLEATS FOR ATTACHMENT TO SPORTS SHOES; CLIMBING BOOTS; CLIMBING FOOTWEAR; CLIMBING SHOES; CLOGS; CLOTH BIBS; CLOTHING ITEMS, NAMELY, ADHESIVE POCKETS THAT MAY BE AFFIXED DIRECTLY TO THE BODY AS A DECORATIVE PIECE OF CLOTHING WITH UTILITY; CLOTHING ITEMS, NAMELY, ADHESIVE POCKETS THAT MAY BE AFFIXED DIRECTLY TO THE INSIDE OF CLOTHING FOR STORAGE AND SAFEKEEPING OF PERSONAL ITEMS; CLOTHING, NAMELY, ARM WARMERS; CLOTHING, NAMELY, HAND-WARMERS; CLOTHING, NAMELY, KHAKIS; CLOTHING, NAMELY, WRAP-AROUNDS; COATS; COATS FOR MEN AND WOMEN; COATS MADE OF COTTON; COATS OF DENIM; CYCLING SHOES; CYCLISTS' JERSEYS; DANCE SHOES; DECK-SHOES; DENIM JACKETS; DENIMS; DOWN JACKETS; EAR BANDS; EAR MUFFS; EAR WARMERS; EARBANDS; EMBOSSED SOLES AND HEELS OF RUBBER OR OF PLASTIC MATERIALS; ESPADRILLES; EUROPEAN FOOTBALL BIBS; FABRIC BELTS; FITTED SHOE OR BOOT COVERING TO PROTECT THE SHOES OR BOOT FROM WATER OR OTHER DAMAGE; FLEECE PULLOVERS; FLEECE SHORTS; FLEECE VESTS; FOOTBALL BOOTS AND STUDS THEREFOR; FOOTBALL SHOES; FOOTIES; FOOTWEAR FOR TRACK AND FIELD ATHLETICS; FOOTWEAR MADE OF WOOD; FOOTWEAR, NAMELY, PUMPS; FOOTWEAR, NAMELY, RUBBERS; FUR CLOAKS; FUR COATS; GLOVES; GLOVES AS CLOTHING; GLOVES FOR APPAREL; GLOVES FOR PERSONAL HAND CONDITIONING USE; GLOVES INCLUDING THOSE MADE OF SKIN, HIDE OR FUR; GOLF CAPS; GOLF CLEATS; GOLF PANTS, SHIRTS AND SKIRTS; GOLF SHOES; GOLF SHOES; GOLF SHORTS; GOLF SPIKES; GOLF TROUSERS; GYM BOOTS; GYM PANTS; GYM SHORTS; GYM SUITS; GYMNASIIC SHOES; HANDBALL SHOES; HAT BANDS; HATS; HATS FOR INFANTS, BABIES, TODDLERS AND CHILDREN; HEAD SCARVES; HEAD SWEATBANDS; HEAD WEAR; HEADBANDS; HEADBANDS AGAINST SWEATING; HEADBANDS FOR CLOTHING; HEADGEAR, NAMELY, HATS; HEADWEAR; HEAVY COATS; HEAVY JACKETS; HEEL IN-

**CLASS 25—(Continued).**

SERTS; HEEL PIECES FOR SHOES; HEELS; HIKING BOOTS; HOCKEY SHOES; HOODED PULLOVERS; HOODED SWEAT SHIRTS; HOODS; HOODS; HORSE-RIDING BOOTS; INFANT AND TODDLER ONE PIECE CLOTHING; INFANT SLEEPERS; INFANT WEAR; INFANTS' SHOES AND BOOTS; INFANTS' TROUSERS; INFANTWEAR; INNER SOLES; INSOLES; INSOLES; INSOLES FOR FOOTWEAR; JACKET LINERS; JACKETS; JACKETS AND SOCKS; JANDALS; JAPANESE FOOTWEAR OF RICE STRAW (WARAJI); JAPANESE SLEEPING ROBES (NEMAKI); JAPANESE SPLIT-TOED WORK FOOTWEAR (JIKATABI); JAPANESE STYLE CLOGS AND SANDALS; JAPANESE STYLE SANDALS (ZORI); JAPANESE STYLE SANDALS OF FELT; JAPANESE STYLE SANDALS OF LEATHER; JAPANESE STYLE SOCKS (TABI COVERS); JAPANESE STYLE SOCKS (TABI); JAPANESE STYLE WOODEN CLOGS (GETA); JAPANESE TOE-STRAP SANDALS (ASAURAZORI); JEANS; JERSEYS; JOGGING OUTFITS; JOGGING PANTS; JOGGING SUITS; JUMPERS; KERCHIEFS; KIMONOS; KNEE HIGHS; KNEE-HIGH STOCKINGS; KNICKERS; KNIT FACE MASKS; KNIT JACKETS; KNIT SHIRTS; KNITTED CAPS; KNITTED GLOVES; KNITTED UNDERWEAR; KNOT CAPS; KNOTTED CAPS; LACE BOOTS; LADIES' BOOTS; LEATHER BELTS; LEATHER COATS; LEATHER HEADWEAR; LEATHER JACKETS; LEATHER PANTS; LEATHER SHOES; LEATHER SLIPPERS; LEISURE SHOES; LONG JACKETS; LONG JOHN; LONG SLEEVE PULLOVERS; LONG SLEEVED VESTS; LONG UNDERWEAR; LONG-SLEEVED SHIRTS; LOUNGE PANTS; LOUNGEWEAR; MEN'S AND WOMEN'S JACKETS, COATS, TROUSERS, VESTS; MEN'S DRESS SOCKS; MEN'S SOCKS; MEN'S SUITS; MEN'S SUITS, WOMEN'S SUITS; MEN'S UNDERWEAR; MITTENS; MOCCASINS; MOCK TURTLE-NECK SWEATERS; MOISTURE-WICKING SPORTS BRAS; MOISTURE-WICKING SPORTS PANTS; MOISTURE-WICKING SPORTS SHIRTS; MONEY BELTS; MORNING COATS; MOTORCYCLE GLOVES; MOTORCYCLE JACKETS; MOTORCYCLE RAIN SUITS; MOTORCYCLIST BOOTS; MOUNTAINEERING BOOTS; MOUNTAINEERING SHOES; OUTDOOR GLOVES; OVER COATS; OVERALLS; OVERSHOES; PAJAMAS; PANTS; PAPER SHOES USED WHEN GOING THROUGH METAL DETECTORS TO KEEP FEET AND SOCKS CLEAN; PARKAS; POLO KNIT TOPS; POLO SHIRTS; RAIN BOOTS; RAIN COATS; RAIN HATS; RAIN JACKETS; RAINCOATS; RAINWEAR; RIDING BOOTS; RIDING COATS; RIDING GLOVES; RIDING SHOES; RUBBER SHOES; RUBBER SOLES FOR JIKATABI; RUGBY SHIRTS; RUGBY SHOES; RUGBY SHORTS; RUGBY TOPS; RUNNING SHOES; SANDAL-CLOGS; SANDALS; SCARFS; SCARVES; SCHOOL UNIFORMS; SHELL JACKETS; SHIRT FRONTS; SHIRTS; SHIRTS AND SHORT-SLEEVED SHIRTS; SHIRTS FOR INFANTS, BABIES, TODDLERS AND CHILDREN; SHIRTS FOR SUITS; SHOE COVERS FOR USE WHEN WEARING SHOES; SHOE DOWELS; SHOE PEGS; SHOE SOLES; SHOE STRAPS; SHOES; SHOES SOLES FOR REPAIR; SHORT-SLEEVED OR LONG-SLEEVED T-SHIRTS; SHORT-SLEEVED SHIRTS; SHORTS; SHOULDER SCARVES; SHOULDER WRAPS FOR CLOTHING; SKI AND SNOWBOARD SHOES AND PARTS THEREOF; SKI BOOT BAGS; SKI BOOTS; SKI GLOVES; SKI JACKETS; SKI MASKS; SKI SUITS; SKI SUITS FOR COMPETITION; SKI TROUSERS; SKI WEAR; SKIING SHOES; SKULL CAPS; SKULLIES; SLEEVELESS JERSEYS; SLIPPER SOLES; SLIPPERS; SLIPS; SMALL HATS; SNEAKERS; SNOW BOARDING SUITS; SNOW BOOTS; SNOW SUITS; SNOWBOARD GLOVES; SNOWBOARD MITTENS; SOCCER BIBS; SOCCER BOOTS; SOCCER SHOES; SOCK SUSPENDERS; SOCKS; SOCKS AND STOCKINGS; SOLES; SOLES FOR FOOTWEAR; SPORT COATS; SPORT SHIRTS; SPORT STOCKINGS; SPORTS CAPS AND HATS; SPORTS JACKETS; SPORTS JERSEYS; SPORTS JERSEYS AND BREECHES FOR SPORTS; SPORTS OVERUNIFORMS; SPORTS PANTS; SPORTS SHIRTS; SPORTS SHIRTS WITH SHORT SLEEVES; SPORTS VESTS; SUEDE JACKETS; SUIT COATS; SUITS; SUITS OF LEATHER; SUN VISORS; SWEAT JACKETS; SWEAT PANTS; SWEAT SHIRTS; SWEAT SHORTS; SWEAT SUITS; SWEATBANDS; SWEATERS; SWEATSOCKS; T-SHIRTS; TANK TOPS; TEDDIES; TEE SHIRTS; TENNIS SHOES; TENNIS WEAR; THERMAL SOCKS; THERMAL UNDERWEAR; THONGS; THONGS; TIES; TOBOGGAN HATS, PANTS AND CAPS; TOE BOXES; TOE CAPS; TONGUE OR PULLSTRAP FOR SHOES AND BOOTS; TOP COATS;

**CLASS 25—(Continued).**

TOPCOATS; TOPS; TOQUES; TRACK AND FIELD SHOES; TRACK JACKETS; TRACK PANTS; TRACK SUITS; TRACKSUITS; TRAINING SHOES; TRAINING SUITS; TRIATHLON CLOTHING, NAMELY, TRIATHLON TIGHTS, TRIATHLON SHORTS, TRIATHLON SINGLET, TRIATHLON SHIRTS, TRIATHLON SUITS; TUXEDO BELTS; UNDERWEAR; UNDERWEAR, NAMELY, BOY SHORTS; UNIFORMS; V-NECK SWEATERS; VISORS; VOLLEYBALL JERSEYS; VOLLEYBALL SHOES; WAIST BANDS; WAIST BELTS; WALKING SHORTS; WARM UP OUTFITS; WARM UP SUITS; WATER PROOF BOOTS; WATER REPELLING BOOTS; WATER REPELLING FOOTWEAR; WATER REPELLING LEATHER BOOTS; WATER REPELLING LEATHER SHOES AND BOOTS; WATER SOCKS; WATERPROOF FOOTWEAR; WATERPROOF JACKETS AND PANTS; WATERPROOF LEATHER BOOTS; WATERPROOF LEATHER SHOES; WATERPROOF LEATHER SHOES AND BOOTS; WEARABLE BLANKETS IN THE NATURE OF BLANKETS WITH SLEEVES; WEARABLE GARMENTS AND CLOTHING, NAMELY, SHIRTS; WELTS FOR BOOTS AND SHOES; WINTER BOOTS; WOMEN'S HATS AND HOODS; WOMEN'S SHOES; WOODEN SHOES; WORK SHOES AND BOOTS; WORKING OVERALLS; WRIST BANDS; WRISTBANDS; YOGA PANTS; YOGA SHIRTS (U.S. CLS. 22 AND 39).

FIRST USE 2-10-2009; IN COMMERCE 5-1-2009.  
JULIE WATSON, EXAMINING ATTORNEY

**CLASS 25—(Continued).**

SN 85-019,919. DMND, LLC, CALABASAS, CA. FILED 4-21-2010.

## MANJI GARAGE

THE MARK CONSISTS OF STANDARD CHARACTERS WITHOUT CLAIM TO ANY PARTICULAR FONT, STYLE, SIZE, OR COLOR.

THE ENGLISH TRANSLATION OF "MANJI" IN THE MARK IS "WHIRLWIND".

FOR CLOTHING, NAMELY, T-SHIRTS, SHIRTS, TANK TOPS, BLOUSES, SWEATERS, CARDIGANS, SWEATSHIRTS, JEANS, TROUSERS, KHAKI PANTS, CARGO PANTS, CAPRI PANTS, SHORTS, DRESSES, GOWNS, SKIRTS, SWEAT PANTS, SWIMWEAR, BATHING SUITS, SWIM TRUNKS, COATS, RAINWEAR, JACKETS, BLAZERS, RAINCOATS, VESTS, MITTENS, GLOVES, HEADWEAR, HATS, CAPS, VISORS, HEAD BANDS, BANDANNAS, SHOES, PUMPS, SANDALS, SNEAKERS, SPORTS SHOES, BOOTS, SOCKS, SLIPPERS, ROBES, UNDERWEAR, BRIEFS, SLEEPWEAR, PAJAMAS, JUMPSUITS, SCARVES, TIES, BELTS (U.S. CLS. 22 AND 39).

JULIE GUTTADAURO, EXAMINING ATTORNEY

SN 85-022,131. AIR IS FREE, LLC, DURHAM, ME. FILED 4-23-2010.

## Air is Free

THE MARK CONSISTS OF STANDARD CHARACTERS WITHOUT CLAIM TO ANY PARTICULAR FONT, STYLE, SIZE, OR COLOR.

FOR SHIRTS; SHIRTS AND SHORT-SLEEVED SHIRTS; SHORT-SLEEVED OR LONG-SLEEVED T-SHIRTS; T-SHIRTS; TEE SHIRTS (U.S. CLS. 22 AND 39).

FIRST USE 4-19-2010; IN COMMERCE 6-3-2010.  
SHAUNIA CARLYLE, EXAMINING ATTORNEY

SN 85-022,720. LANDS' END DIRECT MERCHANTS, INC., RICHFIELD, MN. FILED 4-26-2010.

## Iron Knees

THE MARK CONSISTS OF A STYLIZED DEPICTION OF THE LETTERS "G" AND "J".

FOR PROMOTIONAL MERCHANDISE IN THE NATURE OF CLOTHING, NAMELY, T-SHIRTS, SWEATSHIRTS, HOODED SWEATSHIRTS, TANK TOPS, JACKETS, SCARVES, HEADWEAR, BASEBALL CAPS AND HATS (U.S. CLS. 22 AND 39).

FIRST USE 5-27-2002; IN COMMERCE 5-27-2002.  
NICHOLAS ALTREE, EXAMINING ATTORNEY

THE MARK CONSISTS OF STANDARD CHARACTERS WITHOUT CLAIM TO ANY PARTICULAR FONT, STYLE, SIZE, OR COLOR.

NO CLAIM IS MADE TO THE EXCLUSIVE RIGHT TO USE "KNEES", APART FROM THE MARK AS SHOWN.

FOR DENIMS; PANTS (U.S. CLS. 22 AND 39).  
ERIN FALK, EXAMINING ATTORNEY

SN 85-018,687. GLASSJAW, NEW YORK, NY. FILED 4-20-2010.



**CLASS 25—(Continued).**

SN 85-023,464. LAURA LEHMANN, NEW YORK, NY. FILED 4-26-2010.

# eve at noon

THE MARK CONSISTS OF STANDARD CHARACTERS WITHOUT CLAIM TO ANY PARTICULAR FONT, STYLE, SIZE, OR COLOR.

FOR CLOTHING, NAMELY, T SHIRTS, SHIRTS, TOPS, JACKETS (U.S. CLS. 22 AND 39).  
ANNE MADDEN, EXAMINING ATTORNEY

**CLASS 25—(Continued).**

SN 85-030,213. POLISHED PENNY, FLORAL PARK, NY. FILED 5-4-2010.



SN 85-024,266. FORSBERG, ANNA M, LAKEWOOD, CA. FILED 4-27-2010.

# swearerver

THE MARK CONSISTS OF STANDARD CHARACTERS WITHOUT CLAIM TO ANY PARTICULAR FONT, STYLE, SIZE, OR COLOR.

FOR T-SHIRTS (U.S. CLS. 22 AND 39).  
FIRST USE 1-1-1010; IN COMMERCE 1-1-1010.  
GENE MACIOL, EXAMINING ATTORNEY

THE MARK CONSISTS OF THE TEXT "POLISHED PENNY" IN AN ITALIC CALLIGRAPHY FONT.

FOR CLOTHING, NAMELY, WOVEN AND KNIT TOPS SHORT SLEEVE AND LONG, HATS, BELTS, SOCKS, SHOES, TIES, POCKET SQUARES, JEANS, PANTS, JACKETS, COATS, WIND-RESISTANT JACKETS AND SUSPENDERS (U.S. CLS. 22 AND 39).  
RONALD AIKENS, EXAMINING ATTORNEY

SN 85-031,490. THRONEBURG, JAMES L., STATESVILLE, NC. FILED 5-6-2010.

# PURE

SN 85-025,769. RODGERS, WILLIAM J., LA JOLLA, CA. FILED 4-28-2010.

# GOT BOOBS?

THE MARK CONSISTS OF STANDARD CHARACTERS WITHOUT CLAIM TO ANY PARTICULAR FONT, STYLE, SIZE, OR COLOR.

FOR CLOTHING, NAMELY, SHIRTS, HATS, SWEATSHIRTS, AND JACKETS (U.S. CLS. 22 AND 39).  
JORDAN BAKER, EXAMINING ATTORNEY

THE MARK CONSISTS OF STANDARD CHARACTERS WITHOUT CLAIM TO ANY PARTICULAR FONT, STYLE, SIZE, OR COLOR.

OWNER OF U.S. REG. NOS. 2,877,863 AND 2,937,200.  
FOR CLOTHING, NAMELY, ATHLETIC APPAREL, NAMELY, TEE SHIRTS, SWEATSHIRTS, SWEATPANTS, SHORTS, SOCKS, UNDERWEAR, AND JACKETS; FOOTWEAR AND HEADWEAR (U.S. CLS. 22 AND 39).  
DAWN FELDMAN, EXAMINING ATTORNEY

**CLASS 25—(Continued).**

SN 85-033,662. STONE, LARA H., DBA WOMEN RUN, DARTMOUTH, MA. AND LAWTON, KYRA C., DBA WOMEN RUN, DARTMOUTH, MA. FILED 5-8-2010.

women run

THE MARK CONSISTS OF STANDARD CHARACTERS WITHOUT CLAIM TO ANY PARTICULAR FONT, STYLE, SIZE, OR COLOR.

FOR BASEBALL CAPS AND HATS; APPAREL FOR DANCERS, NAMELY, TEE SHIRTS, SWEATSHIRTS, PANTS, LEGGINGS, SHORTS AND JACKETS; ATHLETIC APPAREL, NAMELY, SHIRTS, PANTS, JACKETS, FOOTWEAR, HATS AND CAPS, ATHLETIC UNIFORMS; CAPS; CLOTHING, NAMELY, BASE LAYERS; HEADBANDS FOR CLOTHING; JACKETS; JERSEYS; SHORT-SLEEVED OR LONG-SLEEVED T-SHIRTS; SPORTS CAPS AND HATS; TOPS; WEARABLE GARMENTS AND CLOTHING, NAMELY, SHIRTS (U.S. CLS. 22 AND 39).

FIRST USE 5-7-2010; IN COMMERCE 5-7-2010.  
BRIAN PINO, EXAMINING ATTORNEY

**CLASS 25—(Continued).**

SN 85-056,429. TMW MARKETING COMPANY, INC., FREMONT, CA. FILED 6-7-2010.



OWNER OF U.S. REG. NO. 3,897,650.

THE MARK CONSISTS OF ASIAN INFLUENCED ABSTRACT BRUSHSTROKES MAKING THE BACKWARDS LETTERS "KO" AND THE LETTERS "E G A R A" BELOW.

THE ENGLISH TRANSLATION OF "EGARA" IN THE MARK IS "PICTURE".

FOR (BASED ON SECTION 1(A)) SHIRTS, JEANS, PANTS; (BASED ON SECTION 1(B)) COATS; TOP COATS; JACKETS; KNIT SHIRTS; LONG-SLEEVED SHIRTS; SHORT-SLEEVED SHIRTS; OPEN-NECKED SHIRTS; SHORT-SLEEVED SHIRTS; SWEATERS (U.S. CLS. 22 AND 39).

FIRST USE 4-12-2010; IN COMMERCE 4-12-2010.  
CHRISTINE COOPER, EXAMINING ATTORNEY

SN 85-050,320. MARCRAFT CLOTHES, INC., CHESTNUT RIDGE, NY. FILED 5-28-2010.

PRIMA SILK

THE MARK CONSISTS OF STANDARD CHARACTERS WITHOUT CLAIM TO ANY PARTICULAR FONT, STYLE, SIZE, OR COLOR.

OWNER OF U.S. REG. NO. 3,544,095.

NO CLAIM IS MADE TO THE EXCLUSIVE RIGHT TO USE "SILK", APART FROM THE MARK AS SHOWN.

FOR MEN'S NESTED TAILORED SUITES; MEN'S SUIT SEPARATES, SLACKS AND TROUSERS, VESTS AND SPORT COATS ALL MADE WHOLLY OR SUBSTANTIALLY OF SILK (U.S. CLS. 22 AND 39).

FIRST USE 12-31-2001; IN COMMERCE 12-31-2001.  
MARLENE BELL, EXAMINING ATTORNEY

SN 85-056,881. HARVEY BALL SMILE LIMITED, SHINAGAWA-KU TOKYO, JAPAN, FILED 6-8-2010.



OWNER OF U.S. REG. NOS. 3,710,458, 3,716,796 AND OTHERS.

THE MARK CONSISTS OF THE DESIGN OF A SMILEY FACE WHERE THE EYES ARE FORMED BY THE LETTERS "S" AND "F" AND THE NOSE IS FORMED BY A STAR. THE WORDING "SMILEY FACE" APPEARS UNDERNEATH THE SMILE.

FOR CAPS; COATS; FOOTWEAR; GLOVES; HATS; NECKTIES; PAJAMAS; PANTS; SCARVES; SHIRTS; SHORTS; SKIRTS; SOCKS AND STOCKINGS; SWEATERS; SWIMSUITS; T-SHIRTS; TROUSERS; UNDERWEAR (U.S. CLS. 22 AND 39).

AMY ALFIERI, EXAMINING ATTORNEY

**CLASS 25—(Continued).**

SN 85-057,068. LAM SYSTEMS, INC., MECHANICSBURG, PA. FILED 6-8-2010.



THE MARK CONSISTS OF THE WORDING "RAK'D UP", AND BENEATH IT THE SKULL OF A DEER AND A BULLET HOLE, ALL INSIDE OF A BULLS EYE TARGET. FOR CLOTHING, NAMELY, TOPS, BOTTOMS, JACKETS, SOCKS; HEADWEAR (U.S. CLS. 22 AND 39). SIMON TENG, EXAMINING ATTORNEY

SN 85-060,558. SKECHERS U.S.A., INC. II, MANHATTAN BEACH, CA. FILED 6-11-2010.

**SHAPE YOUR BOOTY**

THE MARK CONSISTS OF STANDARD CHARACTERS WITHOUT CLAIM TO ANY PARTICULAR FONT, STYLE, SIZE, OR COLOR. FOR FOOTWEAR (U.S. CLS. 22 AND 39). ERIN FALK, EXAMINING ATTORNEY

SN 85-061,777. THE H.D. LEE COMPANY, INC., WILMINGTON, DE. FILED 6-14-2010.

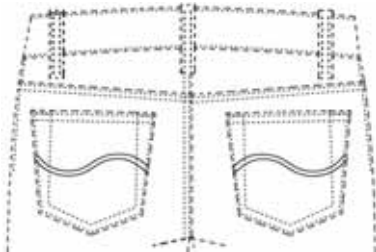

OWNER OF U.S. REG. NO. 1,273,602. THE MARK CONSISTS OF TWO COMPOUND CURVES DISPLAYED ON THE HIP POCKETS OF THE GOODS. THE POCKET AND PANTS OUTLINES SHOWN IN DOTTED LINES ARE NOT PART OF THE MARK AND NO CLAIM IS MADE TO THEM; THE DOTTED LINES MERELY SERVE TO SHOW THE POSITION OF THE MARK. SEC. 2(F). FOR JEANS; SHORTS (U.S. CLS. 22 AND 39). FIRST USE 2-18-1946; IN COMMERCE 2-18-1946. BARNEY CHARLON, EXAMINING ATTORNEY

**CLASS 25—(Continued).**

SN 85-068,524. NORTH TOP USA INC., LOS ANGELES, CA. FILED 6-22-2010.

**ANGEL IN USA**

THE MARK CONSISTS OF STANDARD CHARACTERS WITHOUT CLAIM TO ANY PARTICULAR FONT, STYLE, SIZE, OR COLOR. NO CLAIM IS MADE TO THE EXCLUSIVE RIGHT TO USE "USA", APART FROM THE MARK AS SHOWN. FOR BOMBER JACKETS; DENIM JACKETS; DENIMS; JEANS; PANTS; SHIRTS; SKIRTS; SKIRTS AND DRESSES; SWEATERS (U.S. CLS. 22 AND 39). BERYL GARDNER, EXAMINING ATTORNEY

SN 85-070,207. ACEVEDO, HAROLD, GLENDALE, CA. FILED 6-23-2010.



NO CLAIM IS MADE TO THE EXCLUSIVE RIGHT TO USE "OUTDOOR", APART FROM THE MARK AS SHOWN. THE MARK CONSISTS OF AN ABSTRACT MOUNTAIN RANGE WITH THE STYLIZED TEXT "OUTDOOR HABITAT". FOR JACKETS (U.S. CLS. 22 AND 39). WILLIAM P. SHANAHAN, EXAMINING ATTORNEY

**CLASS 25—(Continued).**

SN 85-071,171. CARLO NICCHIA, LLC, HOLLYWOOD, FL.  
FILED 6-24-2010.



THE NAME "CARLO NICCHIA" DOES NOT IDENTIFY A LIVING INDIVIDUAL.

THE MARK CONSISTS OF A BUTTERFLY WITH THE STYLIZED TEXT "CARLO NICCHIA".  
FOR POLO SHIRTS; T-SHIRTS (U.S. CLS. 22 AND 39).  
LAURIE KAUFMAN, EXAMINING ATTORNEY

**CLASS 25—(Continued).**

SN 85-091,442. CORTADA, MICHAEL, S, TA HOTLIFE,  
OVIEDO, FL. FILED 7-23-2010.



THE MARK CONSISTS OF THE TERMS "HOT LIFE" IN STYLIZED LETTERING.

FOR SHORT-SLEEVED OR LONG-SLEEVED T-SHIRTS (U.S. CLS. 22 AND 39).  
FIRST USE 6-5-2008; IN COMMERCE 6-5-2008.  
PAULA MAHONEY, EXAMINING ATTORNEY

SN 85-071,861. KRISTIN FRAZER, TORTOLA, BR.VIRGIN ISLANDS, FILED 6-25-2010.

TRÈFLE

THE MARK CONSISTS OF STANDARD CHARACTERS WITHOUT CLAIM TO ANY PARTICULAR FONT, STYLE, SIZE, OR COLOR.

THE ENGLISH TRANSLATION OF "TRÈFLE" IN THE MARK IS "CLOVER".

FOR SWIMWEAR (U.S. CLS. 22 AND 39).  
FIRST USE 8-0-2008; IN COMMERCE 8-0-2009.  
AISHA CLARKE, EXAMINING ATTORNEY

SN 85-092,765. PACIFIC TRADING VENTURES LLC,  
BROOKLYN, NY. FILED 7-26-2010.

SWISS CROSS

THE MARK CONSISTS OF STANDARD CHARACTERS WITHOUT CLAIM TO ANY PARTICULAR FONT, STYLE, SIZE, OR COLOR.

FOR MEN'S, WOMEN'S, CHILDREN'S AND INFANTS' CLOTHING, NAMELY, SHIRTS, BLOUSES, PANTS, SHORTS, HOSIERY, JACKETS, UNDERWEAR, SWEATERS, HATS, BATHING SUITS AND SLEEPWEAR (U.S. CLS. 22 AND 39).

BILL DAWE, EXAMINING ATTORNEY

SN 85-078,291. PETERS, TOBY T., GREENWICH, CT. FILED 7-6-2010.

TOBY TUCKER

THE MARK CONSISTS OF STANDARD CHARACTERS WITHOUT CLAIM TO ANY PARTICULAR FONT, STYLE, SIZE, OR COLOR.

THE NAME(S), PORTRAIT(S), AND/OR SIGNATURE(S) SHOWN IN THE MARK IDENTIFIES "TOBY TUCKER", WHOSE CONSENT(S) TO REGISTER IS MADE OF RECORD.

FOR LADIES' SPORTS ATTIRE, NAMELY, JACKETS, SLACKS, NECKTIES, HATS, CAPS, VISORS, LADIES' BLOUSES, SKIRTS, SWEATERS, SHIRTS, SHORTS, SOCKS, SCARVES, APRONS, AND FOOTWEAR, NAMELY, GOLF SHOES AND SNEAKERS (U.S. CLS. 22 AND 39).

KATHERINE CHANG, EXAMINING ATTORNEY

SN 85-093,835. ATLANTA FALCONS FOOTBALL CLUB, LLC, FLOWERY BRANCH, GA. FILED 7-27-2010.



THE MARK CONSISTS OF THE LETTERS "ATL" WITH A STYLIZED WING EXTENDING FROM THE LEFT OF THE "A".

FOR HEADWEAR; SHIRTS (U.S. CLS. 22 AND 39).  
FIRST USE 7-16-2010; IN COMMERCE 7-16-2010.  
JAMES A. RAUEN, EXAMINING ATTORNEY

**CLASS 25—(Continued).**

SN 85-094,371. LUCKETT ENTERPRISES LLC, SAN PABLO, CA. FILED 7-28-2010.

**New Swagga  
Todd Carrington**

THE MARK CONSISTS OF STANDARD CHARACTERS WITHOUT CLAIM TO ANY PARTICULAR FONT, STYLE, SIZE, OR COLOR.

THE NAME(S), PORTRAIT(S), AND/OR SIGNATURE(S) SHOWN IN THE MARK DOES NOT IDENTIFY A PARTICULAR LIVING INDIVIDUAL.

FOR ATHLETIC APPAREL, NAMELY, SHIRTS, PANTS, JACKETS, FOOTWEAR, HATS AND CAPS, ATHLETIC UNIFORMS (U.S. CLS. 22 AND 39).

ROBERT C. CLARK JR., EXAMINING ATTORNEY

SN 85-095,368. JR. MOORE, RICKY F., RALEIGH, NC. FILED 7-28-2010.



THE NAME(S), PORTRAIT(S), AND/OR SIGNATURE(S) SHOWN IN THE MARK IDENTIFIES "NYLA ELISE MOORE", WHOSE CONSENT(S) TO REGISTER IS MADE OF RECORD.

THE MARK CONSISTS OF A CAPITAL "N" AND A BACKWARDS CAPITAL "E", THE CAPITAL "N" AND THE BACKWARDS CAPITAL "E" ARE ARRANGED SIDE-BY-SIDE. THE WORDS "NYLA ELISE" APPEAR UNDER THE CAPITAL "N" AND BACKWARDS CAPITAL "E".

FOR CLOTHING, NAMELY, T-SHIRTS, SWEATSHIRTS, AND POLO STYLE SHIRTS (U.S. CLS. 22 AND 39).

FIRST USE 5-1-2007; IN COMMERCE 5-1-2009.  
DEIRDRE ROBERTSON, EXAMINING ATTORNEY

**CLASS 25—(Continued).**

SN 85-107,710. MCDONALD, GARY O, AKA GMAC, FRISCO, TX. FILED 8-14-2010.

**DutchField Brand**

NO CLAIM IS MADE TO THE EXCLUSIVE RIGHT TO USE "BRAND", APART FROM THE MARK AS SHOWN.

THE MARK CONSISTS OF THE WORDING "DUTCH-FIELD BRAND" THE LETTERS OF WHICH ARE BROKEN UP BY SPACES.

FOR APPAREL FOR DANCERS, NAMELY, TEE SHIRTS, SWEATSHIRTS, PANTS, LEGGINGS, SHORTS AND JACKETS; ATHLETIC APPAREL, NAMELY, SHIRTS, PANTS, JACKETS, FOOTWEAR, HATS AND CAPS, ATHLETIC UNIFORMS; CHILDREN'S AND INFANT'S APPAREL, NAMELY, JUMPERS, OVERALL SLEEPWEAR, PAJAMAS, ROMPERS AND ONE-PIECE GARMENTS; GLOVES FOR APPAREL; SCIENTIFIC AND TECHNOLOGICAL APPAREL, NAMELY, SHIRTS, PANTS, JACKETS, FOOTWEAR, HATS AND CAPS, UNIFORMS; VISCOUS GEL POLYMER SOLD AS A COMPONENT OF FINISHED CUSTOM CUSHIONED FOOTWEAR FOR NON-ORTHOPEDIC PURPOSES AND APPAREL (U.S. CLS. 22 AND 39).

LESLEY LAMOTHE, EXAMINING ATTORNEY

SN 85-108,149. THE BON-TON TRADE, LLC, WILMINGTON, DE. FILED 8-16-2010.

**ZOE & BELLA**

THE MARK CONSISTS OF STANDARD CHARACTERS WITHOUT CLAIM TO ANY PARTICULAR FONT, STYLE, SIZE, OR COLOR.

FOR INTIMATE APPAREL, NAMELY, SLEEPWEAR IN THE NATURE OF CHEMISES, PAJAMAS, SLEEP SHIRTS, AND GOWNS; ROBES; LOUNGEWEAR; DAYWEAR, NAMELY, CAMISOLES AND WOMEN'S TOP SETS, NAMELY, CAMISOLE/PANTY AND/OR CAMISOLE/SHORTS SOLD IN SETS; SLIPS; AND PANTIES (U.S. CLS. 22 AND 39).

BRENDAN MCCAULEY, EXAMINING ATTORNEY



**CLASS 25—(Continued).**

SN 85-108,281. HAMRICKS, INC., GAFFNEY, SC. FILED 8-16-2010.

# Amanda Jade

THE MARK CONSISTS OF STANDARD CHARACTERS WITHOUT CLAIM TO ANY PARTICULAR FONT, STYLE, SIZE, OR COLOR.

THE NAME SHOWN IN THE MARK DOES NOT IDENTIFY A PARTICULAR LIVING INDIVIDUAL.

FOR CLOTHING, NAMELY, SHIRTS, T-SHIRTS, TOPS, BLOUSES, SWEATERS, SWEATSHIRTS, SWEATPANTS, PANTS, JEANS, SHORTS, PAJAMAS, SLEEPWEAR, JACKETS, COATS, VESTS, FOOTWEAR, SHOES, SKIRTS, DRESSES (U.S. CLS. 22 AND 39).

FIRST USE 4-5-2010; IN COMMERCE 4-5-2010.

MICHAEL KEATING, EXAMINING ATTORNEY

---

SN 85-110,790. HILAIRE, STANLEY, WEST PALM BEACH, FL. FILED 8-18-2010.



THE MARK CONSISTS OF A TRIANGULAR GRAPHIC ELEMENT SHAPED LIKE A PAPER PLANE AND THE WORD "IBAKI" BELOW.

FOR CLOTHING, NAMELY, T-SHIRTS, PANTS, JEANS, LEGGINGS, BELTS, JACKETS, HOODED SWEATERS, HOODED PULLOVERS, SWEATERS, SWIMWEAR, POLO SHIRTS, CARDIGANS, VESTS, UNDERWEAR, MITTENS, GLOVES, SCARVES, SOCKS, SHOES, SNEAKERS, HATS, SKI CAPS, SKULL CAPS, WRIST BANDS, AND JERSEYS (U.S. CLS. 22 AND 39).

FIRST USE 1-15-2010; IN COMMERCE 8-7-2010.

KIM SAITO, EXAMINING ATTORNEY

**CLASS 25—(Continued).**

SN 85-111,343. A PURPLE THELLIE PRODUCTION, INC., NEW YORK, NY. FILED 8-19-2010.

# Arthel Neville

THE MARK CONSISTS OF STANDARD CHARACTERS WITHOUT CLAIM TO ANY PARTICULAR FONT, STYLE, SIZE, OR COLOR.

THE NAME(S), PORTRAIT(S), AND/OR SIGNATURE(S) SHOWN IN THE MARK IDENTIFIES "ARTHEL NEVILLE", A LIVING INDIVIDUAL WHOSE CONSENT(S) TO REGISTER IS MADE OF RECORD.

FOR WOMEN'S CLOTHING AND FASHION ACCESSORIES, NAMELY, DRESSES, COATS, SHORTS, SKIRTS, SHIRTS, PANTS, DRESS PANTS, SWEATERS, JACKETS, SUITS, BLOUSES, KNIT TOPS, VESTS, WIND AND RAIN RESISTANT JACKETS, HATS, RAIN RESISTANT HATS, SWEATSHIRTS, SWEATPANTS, SKI JACKETS, HEADWEAR, GLOVES (U.S. CLS. 22 AND 39).

MARGARET POWER, EXAMINING ATTORNEY

---

SN 85-119,622. O'NEILL, SHANE D., DBA QUINND OG INVESTMENTS LLC., LOS ANGELES, CA. FILED 8-31-2010.

HELPING P.E.T.S (PREVENT  
EUTHANASIA THROUGH SPAYING)

THE MARK CONSISTS OF STANDARD CHARACTERS WITHOUT CLAIM TO ANY PARTICULAR FONT, STYLE, SIZE, OR COLOR.

FOR SHIRTS AND SHORT-SLEEVED SHIRTS; SHORT-SLEEVED OR LONG-SLEEVED T-SHIRTS; SHORT-SLEEVED SHIRTS; T-SHIRTS (U.S. CLS. 22 AND 39).

FIRST USE 7-1-2010; IN COMMERCE 8-1-2010.

LINDA ORNDORFF, EXAMINING ATTORNEY

**CLASS 25—(Continued).**

SN 85-120,638. MICHAEL L MAZZINA, CLEWISTON, FL.  
FILED 9-1-2010.

# TOP wear

THE MARK CONSISTS OF STANDARD CHARACTERS WITHOUT CLAIM TO ANY PARTICULAR FONT, STYLE, SIZE, OR COLOR.

NO CLAIM IS MADE TO THE EXCLUSIVE RIGHT TO USE "WEAR", APART FROM THE MARK AS SHOWN.

FOR A-SHIRTS; ADULT NOVELTY GAG CLOTHING ITEM, NAMELY, SOCKS; ANGLERS' SHOES; ANKLE SOCKS; ANKLETS; ANTI-PERSPIRANT SOCKS; APPAREL FOR DANCERS, NAMELY, TEE SHIRTS; SWEAT-SHIRTS, PANTS, LEGGINGS, SHORTS AND JACKETS; APRES-SKI SHOES; AQUA SHOES; ATHLETIC APPAREL, NAMELY, SHIRTS, PANTS, JACKETS, FOOTWEAR, HATS AND CAPS, ATHLETIC UNIFORMS; ATHLETIC SHOES; BALLET SHOES; BALLOON PANTS; BALLROOM DANCING SHOES; BASEBALL CAPS; BASEBALL CAPS AND HATS; BASEBALL SHOES; BATHING CAPS; BEACH SHOES; BED JACKETS; BERMUDA SHORTS; BIB SHORTS; BICYCLE GLOVES; BICYCLING GLOVES; BOARD SHORTS; BOAT SHOES; BODY SHIRTS; BOMBER JACKETS; BOWLING SHOES; BOXER SHORTS; BOXING SHOES; BOXING SHORTS; BRIEFS; BUCKET CAPS; BUTTON DOWN SHIRTS; BUTTON-FRONT ALOHA SHIRTS; CAMOUFLAGE GLOVES; CAMOUFLAGE JACKETS; CAMOUFLAGE PANTS; CAMOUFLAGE SHIRTS; CAMP SHIRTS; CANVAS SHOES; CAP PEAKS; CAP VISORS; CAPRI PANTS; CAPS; CAPS WITH VISORS; CARGO PANTS; CHEF'S HATS; CLEATS FOR ATTACHMENT TO SPORTS SHOES; CLIMBING SHOES; CLOTHING FOR ATHLETIC USE, NAMELY, PADDED PANTS; CLOTHING FOR ATHLETIC USE, NAMELY, PADDED SHIRTS; CLOTHING FOR ATHLETIC USE, NAMELY, PADDED SHORTS; CLOTHING SHIELDS, NAMELY, PADS APPLIED TO THE UNDERARMS OF SHIRTS; BLOUSES AND SWEATERS; COLLARED SHIRTS; CROSS-COUNTRY GLOVES; CYCLING SHOES; DANCE SHOES; DECK-SHOES; DENIM JACKETS; DENIMS; DISPOSABLE UNDERWEAR; DOWN JACKETS; DRESS PANTS; DRESS SHIRTS; DRIVERS; FISHERMEN'S JACKETS; FISHING SHIRTS; FITTED SHOE OR BOOT COVERING TO PROTECT THE SHOES OR BOOT FROM WATER OR OTHER DAMAGE; FLEECE SHORTS; FOOTBALL SHOES; FUR COATS AND JACKETS; FUR HATS; FUR JACKETS; GLOVES; GLOVES AS CLOTHING; GLOVES FOR APPAREL; GLOVES FOR PERSONAL HAND CONDITIONING USE; GLOVES INCLUDING THOSE MADE OF SKIN, HIDE OR FUR; GOLF CAPS; GOLF CLEATS; GOLF PANTS, SHIRTS AND SKIRTS; GOLF SHIRTS; GOLF SHOES; GOLF SHORTS; GOLF SPIKES; GOLF TROUSERS; GYM PANTS; GYM SHORTS; GYMNASTIC SHOES; HANDBALL SHOES; HAT BANDS; HATS; HATS FOR INFANTS, BABIES, TODDLERS AND CHILDREN; HEAVY JACKETS; HEEL PIECES FOR SHOES; HOCKEY SHOES; HOODED SWEAT SHIRTS; HUNTING JACKETS; HUNTING PANTS; HUNTING SHIRTS; INFANTS' SHOES AND BOOTS; INSOLES; JACKET LINERS; JACKETS; JACKETS AND SOCKS; JAPANESE STYLE SOCKS (TABI COVERS); JAPANESE STYLE SOCKS (TABI); JEGGINGS, NAMELY, PANTS THAT ARE PARTIALLY JEANS AND PARTIALLY LEGGINGS; JOGGING PANTS; KNIT JACKETS; KNIT SHIRTS; KNITTED CAPS; KNITTED GLOVES; KNITTED UNDERWEAR; KNOT CAPS; KNOTTED CAPS; LADIES' UNDERWEAR; LEATHER HATS; LEATHER JACKETS; LEATHER PANTS; LEATHER SHIRTS; LEATHER SHOES; LEG SHIELDING DEVICE, ATTACHABLE TO AND DETACHABLE FROM A PERSON'S PANTS, COMPRISED OF PADDING TO SHIELD THE LEGS FROM FLYING DEBRIS WHEN MOWING WITH A STRING TRIMMER; LEISURE SHOES; LIGHT-REFLECTING JACKETS; LONG JACKETS; LONG UNDERWEAR; LONG-SLEEVED SHIRTS; LOUNGE PANTS; MEN'S AND WOMEN'S JACKETS, COATS, TROUSERS, VESTS; MEN'S DRESS SOCKS; MEN'S SOCKS; MEN'S UNDERWEAR;

**CLASS 25—(Continued).**

MOISTURE-WICKING SPORTS PANTS; MOISTURE-WICKING SPORTS SHIRTS; MOTORCYCLE GLOVES; MOTORCYCLE JACKETS; MOUNTAINEERING SHOES; NIGHT SHIRTS; NON-DISPOSABLE CLOTH TRAINING PANTS; NURSE PANTS; OPEN-NECKED SHIRTS; OUT-DOOR GLOVES; OUTER JACKETS; OVER SHIRTS; PADDED JACKETS; PADDING JACKETS; PANTIES, SHORTS AND BRIEFS; PANTS; PAPER HATS FOR USE AS CLOTHING ITEMS; PAPER SHOES USED WHEN GOING THROUGH METAL DETECTORS TO KEEP FEET AND SOCKS CLEAN; PARTS OF CLOTHING, NAMELY, GUSSETS FOR TIGHTS, GUSSETS FOR STOCKINGS, GUSSETS FOR BATHING SUITS, GUSSETS FOR UNDERWEAR, GUSSETS FOR LEOTARDS AND GUSSETS FOR FOOTLETS; PARTY HATS; PERSPIRATION ABSORBENT STRAP TO BE USED IN THE BILL OF A HAT; PERSPIRATION ABSORBENT UNDERWEAR CLOTHING; PETTI-PANTS; PIQUE SHIRTS; POLO SHIRTS; POLYMER CUSTOM CUSHIONED SHOE INSERTS FOR PRIMARILY NON-ORTHOPEDIC PURPOSES; PROTECTIVE METAL MEMBERS FOR SHOES AND BOOTS; RAIN HATS; RAIN JACKETS; RAIN-PROOF JACKETS; REVERSIBLE JACKETS; RIDING GLOVES; RIDING SHOES; RUBBER SHOES; RUGBY SHIRTS; RUGBY SHOES; RUGBY SHORTS; RUNNING PADS THAT STRAP ONTO SHOES; RUNNING SHOES; SANDALS AND BEACH SHOES; SCIENTIFIC AND TECHNOLOGICAL APPAREL, NAMELY, SHIRTS, PANTS, JACKETS, FOOTWEAR, HATS AND CAPS, UNIFORMS; SEDGE HATS (SUGE-GASA); SHELL JACKETS; SHIRT FRONTS; SHIRT YOKES; SHIRTS; SHIRTS AND SHORT-SLEEVED SHIRTS; SHIRTS AND SLIPS; SHIRTS FOR INFANTS, BABIES, TODDLERS AND CHILDREN; SHIRTS FOR SUITS; SHOE COVERS FOR USE WHEN WEARING SHOES; SHOE DOWELS; SHOE INSERTS FOR PRIMARILY NON-ORTHOPEDIC PURPOSES; SHOE PEGS; SHOE SOLES; SHOE STRAPS; SHOES; SHOES SOLES FOR REPAIR; SHOES WITH HOOK AND PILE FASTENING TAPES; SHORT OVERCOAT FOR KIMONO (HAORI); SHORT PETTICOATS; SHORT SETS; SHORT TROUSERS; SHORT-SLEEVED OR LONG-SLEEVED T-SHIRTS; SHORT-SLEEVED SHIRTS; SHORTS; SHOWER CAPS; SKI AND SNOWBOARD SHOES AND PARTS THEREOF; SKI GLOVES; SKI JACKETS; SKI PANTS; SKIING SHOES; SKULL CAPS; SLEEP PANTS; SLEEP SHIRTS; SLEEVED OR SLEEVELESS JACKETS; SLEEVES WORN SEPARATE AND APART FROM BLOUSES, SHIRTS AND OTHER TOPS; SLIDING SHORTS; SLIPPER SOCKS; SMALL HATS; SMOKING JACKETS; SNOW PANTS; SNOWBOARD GLOVES; SNOWBOARD JACKETS; SNOWBOARD PANTS; SOCCER SHOES; SOCK SUSPENDERS; SOCKS; SOCKS AND STOCKINGS; SPORT SHIRTS; SPORTS CAPS AND HATS; SPORTS JACKETS; SPORTS PANTS; SPORTS SHIRTS; SPORTS SHIRTS WITH SHORT SLEEVES; STRETCH PANTS; STUFF JACKETS; SUEDE JACKETS; SWEAT JACKETS; SWEAT PANTS; SWEAT SHIRTS; SWEAT SHORTS; SWIM CAPS; SWIMMING CAPS; SWIMMING CAPS; T-SHIRTS; TAP PANTS; TAP SHOES; TEE SHIRTS; TENNIS SHOES; THERMAL SOCKS; THERMAL UNDERWEAR; THONGS; TOBOGGAN HATS, PANTS AND CAPS; TOE CAPS; TONGUE OR PULLSTRAP FOR SHOES AND BOOTS; TRACK AND FIELD SHOES; TRACK JACKETS; TRACK PANTS; TRAINING SHOES; TRAVEL CLOTHING CONTAINED IN A PACKAGE COMPRISING REVERSIBLE JACKETS, PANTS, SKIRTS, TOPS AND A BELT OR SCARF; TRIATHLON CLOTHING, NAMELY, TRIATHLON TIGHTS, TRIATHLON SHORTS, TRIATHLON SINGLETTS, TRIATHLON SHIRTS, TRIATHLON SUITS; TURTLE NECK SHIRTS; UNDERWEAR; UNDERWEAR, NAMELY, BOY SHORTS; VOLLEYBALL SHOES; WALKING SHORTS; WATER REPELLING LEATHER SHOES AND BOOTS; WATER SOCKS; WATERPROOF JACKETS AND PANTS; WATERPROOF LEATHER SHOES; WATERPROOF LEATHER SHOES AND BOOTS; WEARABLE GARMENTS AND CLOTHING, NAMELY, SHIRTS; WELTS FOR BOOTS AND SHOES; WET SUIT GLOVES; WIND PANTS; WIND RESISTANT JACKETS; WIND SHIRTS; WIND-JACKETS; WOMEN'S HATS AND HOODS; WOMEN'S SHOES; WOMEN'S UNDERWEAR; WOODEN SHOES; WOOLLEN SOCKS; WOOLLY HATS; WORK SHOES AND BOOTS; WOVEN OR KNITTED UNDERWEAR; YOGA PANTS; YOGA SHIRTS (U.S. CLS. 22 AND 39).

INGA ERVIN, EXAMINING ATTORNEY

**CLASS 25—(Continued).**

SN 85-120,991. XUMING WANG, DBA METRO SPORTS, INC., STIRLING, NJ. FILED 9-1-2010.



THE COLOR(S) BLUE IS/ARE CLAIMED AS A FEATURE OF THE MARK.

THE MARK CONSISTS OF THE STYLIZED LETTERS "JO" BOTH LETTERS IN BLUE WHEREIN THE LETTERS "J" AND "O" ARE INTERTWINED WITH THE LETTER "J" IN THE UPPER HALF AND THE LETTER "O" IN THE LOWER HALF.

FOR ATHLETIC APPAREL, NAMELY, SHIRTS, PANTS, JACKETS, FOOTWEAR, HATS AND CAPS, ATHLETIC UNIFORMS (U.S. CLS. 22 AND 39).

FIRST USE 8-1-2009; IN COMMERCE 8-1-2009.  
 NAPOLEON SHARMA, EXAMINING ATTORNEY

SN 85-121,331. R.N'OVATE, INC., LOS ANGELES, CA. FILED 9-1-2010.

## ROZAE R.N.

THE MARK CONSISTS OF STANDARD CHARACTERS WITHOUT CLAIM TO ANY PARTICULAR FONT, STYLE, SIZE, OR COLOR.

OWNER OF U.S. REG. NOS. 2,481,695 AND 3,842,137.  
 FOR CLOTHING, DRESSES, SKIRTS, TOPS, BOTTOMS, TROUSERS, JACKETS, SWEATERS, BLOUSES, SUITS, SHIRTS, SCARVES, HANDBAGS, FOOTWEAR, SHOES, JEWELRY (U.S. CLS. 22 AND 39).

MIDGE BUTLER, EXAMINING ATTORNEY

SN 85-123,319. JOSEPH J. BUSA, DBA JJB ENTERPRISES, AVON, OH. FILED 9-4-2010.

## Natural Elevation

THE MARK CONSISTS OF STANDARD CHARACTERS WITHOUT CLAIM TO ANY PARTICULAR FONT, STYLE, SIZE, OR COLOR.

FOR HATS; JACKETS; PANTS; SWEAT SHIRTS; T-SHIRTS (U.S. CLS. 22 AND 39).

LINDA ORNDORFF, EXAMINING ATTORNEY

**CLASS 25—(Continued).**

SN 85-124,177. DCTY CO., LTD, SEOUL, REPUBLIC OF KOREA, FILED 9-7-2010.

## CAPTAIN PAPA

THE MARK CONSISTS OF STANDARD CHARACTERS WITHOUT CLAIM TO ANY PARTICULAR FONT, STYLE, SIZE, OR COLOR.

OWNER OF REPUBLIC OF KOREA REG. NO. 0699025, DATED 2-20-2007, EXPIRES 2-20-2017.

THE NAME(S), PORTRAIT(S), AND/OR SIGNATURE(S) SHOWN IN THE MARK DOES NOT IDENTIFY A PARTICULAR LIVING INDIVIDUAL.

FOR LEATHER SHOES; SANDALS; SLIPPERS; BOOTS; SHOES; GOLF SHOES; JACKETS; T-SHIRTS; BLOUSES; SWEATERS; CARDIGANS; VESTS; JEANS; JUMPERS; SKIRTS; LONG COATS; HALF COATS; PANTS; RAIN COATS; ONE PIECE SUITS; CHILDREN'S CLOTHING, NAMELY, PANTS, SHIRTS, JACKETS, SWEATERS, SKIRTS, SHOES; INFANTS' CLOTHING, NAMELY INFANT WEAR; SWIMSUITS; UNDERWEAR; NIGHTWEAR; BELTS FOR CLOTHING; SUSPENDERS FOR STOCKINGS; SOCK SUSPENDERS; HEADWEAR; SOCKS; SCARVES; NECKTIES; GLOVES FOR CLOTHING; SHAWLS; MUFFLERS (U.S. CLS. 22 AND 39).

LIEF MARTIN, EXAMINING ATTORNEY

SN 85-124,436. RUIZ, JEREMY, WIMBERLEY, TX. FILED 9-7-2010.



NO CLAIM IS MADE TO THE EXCLUSIVE RIGHT TO USE "CAMO", APART FROM THE MARK AS SHOWN.

THE MARK CONSISTS OF THE STYLIZED WORDS "CAMO CARTEL". AN IMAGE OF A DUCK SKULL WITH DEER ANTLERS AND TURKEY LEG WITHIN CROSS BONES ABOVE THE TEXT.

FOR CAPS; JACKETS; SHIRTS; T-SHIRTS (U.S. CLS. 22 AND 39).

DANIEL CAPSHAW, EXAMINING ATTORNEY

**CLASS 25—(Continued).**

SN 85-129,602. DENIM REVOLUTION INC., LOS ANGELES, CA. FILED 9-14-2010.

**DENIM REVOLUTION**

THE MARK CONSISTS OF STANDARD CHARACTERS WITHOUT CLAIM TO ANY PARTICULAR FONT, STYLE, SIZE, OR COLOR.

NO CLAIM IS MADE TO THE EXCLUSIVE RIGHT TO USE "DENIM", APART FROM THE MARK AS SHOWN.

FOR CLOTHING FOR MEN, WOMEN, CHILDREN, NAMELY, JACKETS, COATS, SHIRTS, T-SHIRTS, TOPS, PANTS, JEANS, SHORTS, SWEATSHIRTS, SWEATPANTS, SKIRTS, DRESSES, SWIMSUITS, SOCKS, SHOES, SNEAKERS, SANDALS, HATS, CAPS, AND BELTS FOR CLOTHING (U.S. CLS. 22 AND 39).

KAREN BRACEY, EXAMINING ATTORNEY

SN 85-137,089. MITCHELL, TYRA K, COLUMBIA, SC. FILED 9-23-2010.



THE MARK CONSISTS OF THE WORDING "CUC CHRISTIAN UNDER CONSTRUCTION" IN STYLIZED LETTERS, WITH THE LETTER "U" IN "CUC" FORMED BY A CRANE AND BUILDING DESIGN.

FOR ATHLETIC APPAREL, NAMELY, SHIRTS, PANTS, JACKETS, FOOTWEAR, HATS AND CAPS, ATHLETIC UNIFORMS; BABY LAYETTES FOR CLOTHING; BEACH COVER-UPS; BELTS FOR CLOTHING; BIBS NOT OF CLOTH OR PAPER; BODY SHIRTS; BUTTON DOWN SHIRTS; CHILDREN'S AND INFANTS' CLOTH BIBS; CHILDREN'S CLOTH EATING BIBS; CLOTHING ITEMS, NAMELY, ADHESIVE POCKETS THAT MAY BE AFFIXED DIRECTLY TO THE BODY AS A DECORATIVE PIECE OF CLOTHING WITH UTILITY; CLOTHING, NAMELY, KHAKIS; COLLARED SHIRTS; CREW NECK SWEATERS; DENIM JACKETS; DOWN JACKETS; DRESS SHIRTS; GIFT PACKAGES SOLD AS A UNIT CONSISTING PRIMARILY OF A SWEATSHIRT AND ALSO INCLUDING A PHOTO FRAME, A COFFEE MUG, AND A TOTE BAG; GLOVES AS CLOTHING; GLOVES FOR PERSONAL HAND CONDITIONING USE; GOLF PANTS, SHIRTS AND SKIRTS; GOLF SHIRTS; HEAVY JACKETS; HOODED SWEAT SHIRTS; INFANT AND TODDLER ONE PIECE CLOTHING; JACKETS AND SOCKS; JEANS; LONG-SLEEVED SHIRTS; MEN'S AND WOMEN'S JACKETS, COATS, TROUSERS, VESTS; MOCK TURTLE-NECK SWEATERS; MOTORCYCLE JACKETS; NIGHT SHIRTS; OPEN-NECKED SHIRTS; OVER SHIRTS; PIQUE SHIRTS; POLO SHIRTS; RAIN JACKETS; REVERSIBLE JACKETS; SHIRTS; SHIRTS AND SHORT-SLEEVED SHIRTS; SHIRTS FOR INFANTS, BABIES, TODDLERS AND CHILDREN; SHORT SETS; SHORT-SLEEVED OR LONG-SLEEVED T-SHIRTS; SHORT-SLEEVED SHIRTS; SPORT SHIRTS; SWEAT SHIRTS; SWEATERS; T-SHIRTS; TEE SHIRTS; TIES; TURTLENECK SWEATERS; V-NECK SWEATERS; WEARABLE GARMENTS AND CLOTHING, NAMELY, SHIRTS (U.S. CLS. 22 AND 39).

FIRST USE 8-1-2010; IN COMMERCE 9-1-2010.

JULIE VEPPUMTHARA, EXAMINING ATTORNEY

**CLASS 25—(Continued).**

SN 85-139,558. DIRTY OL' DAWG, RUIDOSO, NM. FILED 9-28-2010.



THE MARK CONSISTS OF A DOG WITH LARGE EARS, LONG TAIL, A SMILE, AND TONGUE HANGING OUT OF HIS MOUTH, LOOKING OVER HIS REAR END. THE DOG IS ENCIRCLED BY TWO BANDS, WITH THE WORDS "DIRTY OL' DAWG" AND "WWW.DIRTYOLDAWG.COM" INSIDE OF THE BANDS.

FOR SHORT-SLEEVED OR LONG-SLEEVED T-SHIRTS; SWEAT SHIRTS (U.S. CLS. 22 AND 39).

WILLIAM P. SHANAHAN, EXAMINING ATTORNEY

SN 85-141,496. SMITH, YEARDLEY, BEVERLY HILLS, CA. FILED 9-29-2010.

**OFF YOU GO!**

THE MARK CONSISTS OF STANDARD CHARACTERS WITHOUT CLAIM TO ANY PARTICULAR FONT, STYLE, SIZE, OR COLOR.

FOR CLOTHING, NAMELY, SHIRTS, T-SHIRTS, DRESSES, SKIRTS, SOCKS, AND BELTS; OUTERWEAR, NAMELY, COATS, JACKETS AND RAINWEAR; HEADWEAR AND FOOTWEAR (U.S. CLS. 22 AND 39).

JAY BESCH, EXAMINING ATTORNEY

SN 85-143,477. SICK BOY, LLC, DAYVILLE, CT. FILED 10-1-2010.

**SICKIES GARAGE**

THE MARK CONSISTS OF STANDARD CHARACTERS WITHOUT CLAIM TO ANY PARTICULAR FONT, STYLE, SIZE, OR COLOR.

OWNER OF U.S. REG. NOS. 2,510,347, 3,027,078 AND 3,840,888.

FOR HATS, T-SHIRTS, SWEAT SHIRTS AND JACKETS (U.S. CLS. 22 AND 39).

FIRST USE 6-6-2006; IN COMMERCE 6-6-2006.

ROBERT STRUCK, EXAMINING ATTORNEY

**CLASS 25—(Continued).**

SN 85-144,310. FRANK LYMAN DESIGN INC., MONTREAL, QUEBEC, CANADA, FILED 10-4-2010.

**FRANK LYMAN DESIGN**

THE MARK CONSISTS OF STANDARD CHARACTERS WITHOUT CLAIM TO ANY PARTICULAR FONT, STYLE, SIZE, OR COLOR.

NO CLAIM IS MADE TO THE EXCLUSIVE RIGHT TO USE "DESIGN", APART FROM THE MARK AS SHOWN.

THE NAME(S), PORTRAIT(S), AND/OR SIGNATURE(S) SHOWN IN THE MARK IDENTIFIES "FRANK LYMAN", WHOSE CONSENT(S) TO REGISTER IS MADE OF RECORD.

FOR CLOTHING, NAMELY, SWEATERS, T-SHIRTS, CAMISOLES, VESTS, CARDIGANS, TURTLENECKS, DRESSES, PANTS, JEANS, JACKETS, BERMUDA SHORTS, SHORTS, SKIRTS, SUITS, JUMPSUITS, BLOUSES, BLAZERS, OVERCOATS, PARKAS, ANORAKS, RAINCOATS, RAIN SLICKERS, SWEATSHIRTS, HOODED SWEATSHIRTS, JERSEYS, JOGGING OUTFITS, DRESSING GOWNS, BEACHWEAR, SWIM SUITS, LEOTARDS, COATS, SLIPOVERS, POLO SHIRTS; HEADWEAR, NAMELY, HATS, BERETS, HEADBANDS, KERICHS, TOQUES; FASHION ACCESSORIES, NAMELY, BELTS, SUSPENDERS, NECKTIES, SCARVES, BANDANAS (U.S. CLS. 22 AND 39).

FIRST USE 10-30-2001; IN COMMERCE 11-14-2001.  
BARBARA BROWN, EXAMINING ATTORNEY

SN 85-144,598. HILL, SOPHIA M., DBA CHARMING ARMINGS, ESCONDIDO, CA. FILED 10-4-2010.

**ARMINGS**

THE MARK CONSISTS OF STANDARD CHARACTERS WITHOUT CLAIM TO ANY PARTICULAR FONT, STYLE, SIZE, OR COLOR.

THE WORDING "ARMINGS" HAS NO MEANING IN A FOREIGN LANGUAGE.

FOR APPAREL FOR DANCERS, NAMELY, TEE SHIRTS, SWEATSHIRTS, PANTS, LEGGINGS, SHORTS AND JACKETS; ATHLETIC APPAREL, NAMELY, SHIRTS, PANTS, JACKETS, FOOTWEAR, HATS AND CAPS, ATHLETIC UNIFORMS; CLOTHING FOR ATHLETIC USE, NAMELY, PADDED ELBOW COMPRESSION SLEEVES BEING PART OF AN ATHLETIC GARMENT; CLOTHING, NAMELY, ARM WARMERS; CLOTHING, NAMELY, ATHLETIC SLEEVES; GLOVES AS CLOTHING; GLOVES FOR APPAREL; TOPS (U.S. CLS. 22 AND 39).

FIRST USE 10-4-2010; IN COMMERCE 10-4-2010.  
KATHY DE JONGE, EXAMINING ATTORNEY

**CLASS 25—(Continued).**

SN 85-144,756. ZAEI APPAREL, PORTLAND, OR. FILED 10-4-2010.



THE MARK CONSISTS OF WINGS WITH THE LETTERS "ZAEI" STYLIZED LIKE COG WHEELS AND GEARS.

FOR HOODED SWEAT SHIRTS; INFANT WEAR; LONG-SLEEVED SHIRTS; SHIRTS AND SHORT-SLEEVED SHIRTS; SKI WEAR; SURF WEAR; SWIM WEAR; T-SHIRTS; WEARABLE GARMENTS AND CLOTHING, NAMELY, SHIRTS (U.S. CLS. 22 AND 39).

DEIRDRE ROBERTSON, EXAMINING ATTORNEY

SN 85-145,815. FURGESON, BRITNEY, GLENDALE, CA. FILED 10-5-2010.

**STICKS AND STRIPES**

THE MARK CONSISTS OF STANDARD CHARACTERS WITHOUT CLAIM TO ANY PARTICULAR FONT, STYLE, SIZE, OR COLOR.

FOR APPAREL, NAMELY, DRESSES, T-SHIRTS, UNDERWEAR, TOPS, BLOUSES, PANTS AND SHORTS; CHILDREN'S CLOTHING, NAMELY, T-SHIRTS, BLOUSES, SWEATERS, PANTS, UNDERWEAR, SOCKS AND LEGGINGS (U.S. CLS. 22 AND 39).

REBECCA SMITH, EXAMINING ATTORNEY

SN 85-147,037. BON JOUR GROUP, L.P., NEW YORK, NY. FILED 10-7-2010.

**BONJOUR**

THE MARK CONSISTS OF STANDARD CHARACTERS WITHOUT CLAIM TO ANY PARTICULAR FONT, STYLE, SIZE, OR COLOR.

OWNER OF U.S. REG. NO. 3,905,816.

THE ENGLISH TRANSLATION OF "BONJOUR" IN THE MARK IS GOOD DAY.

FOR BELTS; BLOUSES; COATS; DRESSES; FOOTWEAR; GLOVES; HEADWEAR; HOSIERY; JACKETS; JEANS; JUMPSUITS; LEGGINGS; LINGERIE; LOUNGEWEAR; MITTENS; PANTS; SCARVES; SHIRTS; SHORTS; SKI WEAR; SKIRTS; SLEEPWEAR; SOCKS; SUITS; SUSPENDERS; SWEATERS; SWIMWEAR; TIES; TOPS; UNDERWEAR; VESTS; WARM UP OUTFITS (U.S. CLS. 22 AND 39).

BENJAMIN OKEKE, EXAMINING ATTORNEY

**CLASS 25—(Continued).**

SN 85-148,901. BENNETT III, AMOS, NORFOLK, VA. FILED 10-8-2010.

Example

THE MARK CONSISTS OF THE WORD "EXAMPLE" IN STYLIZED FORM IN WHICH THE LETTER "E" IS HIGHLY STYLIZED.

FOR SHIRTS; SHIRTS AND SHORT-SLEEVED SHIRTS; SHIRTS FOR INFANTS, BABIES, TODDLERS AND CHILDREN; T-SHIRTS; TEE SHIRTS (U.S. CLS. 22 AND 39).

FIRST USE 12-5-2007; IN COMMERCE 11-6-2009.  
SALLY SHIH, EXAMINING ATTORNEY

SN 85-149,378. MICHAEL GOINS, CARY, NC. FILED 10-11-2010.

UPTURN

THE MARK CONSISTS OF STANDARD CHARACTERS WITHOUT CLAIM TO ANY PARTICULAR FONT, STYLE, SIZE, OR COLOR.

FOR BABY TOPS; BEANIES; BELTS; BOOTS; CAPS; COATS; DENIM JACKETS; DENIM PANTS; DRESSES; FOOTWEAR; HATS; HOODED PULLOVERS; HOODED SWEAT SHIRTS; HOODED SWEATSHIRTS; JACKETS; JEANS; LONG-SLEEVED SHIRTS; PANTS; SHIRTS; SHOES; SHORT-SLEEVED SHIRTS; SHORTS; SPORT COATS; SWEATSHIRTS; T-SHIRTS; TANK TOPS; TANK-TOPS; TEE SHIRTS; THERMAL UNDERWEAR; TOPS (U.S. CLS. 22 AND 39).

FIRST USE 11-11-2009; IN COMMERCE 11-11-2009.  
ODESSA BIBBINS, EXAMINING ATTORNEY

SN 85-149,530. A PROMISE & A KISS, BAY CITY, TX. FILED 10-11-2010.

Exa Blue

THE MARK CONSISTS OF STANDARD CHARACTERS WITHOUT CLAIM TO ANY PARTICULAR FONT, STYLE, SIZE, OR COLOR.

NO CLAIM IS MADE TO THE EXCLUSIVE RIGHT TO USE "BLUE", APART FROM THE MARK AS SHOWN.

FOR BRIDESMAID DRESSES; DRESSES; EVENING DRESSES; JACKETS; SHAWLS; SHOES; VEILS; WEDDING DRESSES (U.S. CLS. 22 AND 39).

DOMINICK J. SALEMI, EXAMINING ATTORNEY

**CLASS 25—(Continued).**

SN 85-151,170. PASCAL, SUSAN, CANYON COUNTRY, CA. FILED 10-13-2010.

TUXYBEAR

THE MARK CONSISTS OF STANDARD CHARACTERS WITHOUT CLAIM TO ANY PARTICULAR FONT, STYLE, SIZE, OR COLOR.

FOR CLOTHING FOR BABIES AND TODDLERS 0-24 MONTHS OLD, NAMELY, ONE-PIECE TUXEDO SUITS AND BOW-TIES (U.S. CLS. 22 AND 39).

FIRST USE 1-1-2008; IN COMMERCE 1-1-2008.  
MICHAEL GAAFAR, EXAMINING ATTORNEY

SN 85-151,490. CHARLTON, JASON, PORT HURON, MI. FILED 10-13-2010.



LIGHT WEIGHT

NO CLAIM IS MADE TO THE EXCLUSIVE RIGHT TO USE "LIGHT WEIGHT", APART FROM THE MARK AS SHOWN.

THE MARK CONSISTS OF A SHIELD WITH THE STYLIZED LETTERS "LW" APPEARING INSIDE THE SHIELD. COMING OUT OF THE SHIELD ARE FEATHERS OF VARIOUS SIZES AND SHAPES. THE STYLIZED WORDS "LIGHT WEIGHT" APPEAR BELOW THE SHIELD.

FOR CLOTHING, NAMELY, T-SHIRTS, LONG SLEEVE SHIRTS, SWEAT-SHIRTS, A-SHIRTS, SLEEVELESS T-SHIRTS, JACKETS, HOODED SWEAT SHIRTS, FLANNEL SHIRTS, SPORTS BRAS, FLEECE BOTTOMS, FLEECE PULLOVERS, FLEECE TOPS, SWEAT PANTS, PANTS, SHORTS, SPANDEX SHORTS, SPANDEX RUNNING PANTS, AND CAPRI PANTS (U.S. CLS. 22 AND 39).

ELIZABETH HUGHITT, EXAMINING ATTORNEY

**CLASS 25—(Continued).**

SN 85-151,561. SOCIETE D'IMPORTATION DE DIFFUSION OU DISTRIBUTION D'ARTICLES DE SPORT S.I.D.A.S., VOIRON, FRANCE, FILED 10-13-2010.

**3FEET**

THE MARK CONSISTS OF STANDARD CHARACTERS WITHOUT CLAIM TO ANY PARTICULAR FONT, STYLE, SIZE, OR COLOR.

PRIORITY CLAIMED UNDER SEC. 44(D) ON FRANCE APPLICATION NO. 103737516, FILED 5-11-2010, REG. NO. 103737516, DATED 5-11-2010, EXPIRES 5-10-2020.

FOR SHOES, SLIPPERS, INNER SLIPPERS FOR SHOES, SANDALS, SOLES, INNER SOLES FOR SHOES, HEELS AND HEELPIECES FOR SHOES; BOOTS; SOCKS (U.S. CLS. 22 AND 39).

CHRISTINA SOBRAL, EXAMINING ATTORNEY

**CLASS 25—(Continued).**

SN 85-153,234. MARR, HESTER, NSW, AUSTRALIA, AND MARR, JIM, NEW, AUSTRALIA, FILED 10-14-2010.

**TEMTNTHINGS**

THE MARK CONSISTS OF STANDARD CHARACTERS WITHOUT CLAIM TO ANY PARTICULAR FONT, STYLE, SIZE, OR COLOR.

OWNER OF U.S. REG. NO. 3,373,071.

FOR CLOTHING FOR WOMEN AND GIRLS, NAMELY, TOPS, SHIRTS, T-SHIRTS, KNIT TOPS, HALTER TOPS, BLOUSES, SMOCK TOPS, SWEATERS, VESTS, BOTTOMS, PANTS, SHORTS, SKIRTS, SLACKS, SWEATPANTS, COATS, JACKETS, JUMPERS, CARDIGANS, DRESSES, SUITS, JUMP SUITS, SWIM WEAR, BELTS, GLOVES, RAINWEAR, SCARVES, SHAWLS, PONCHOS, MUFFLERS, SOCKS, TIGHTS, STOCKINGS, HOSIERY, LEGGINGS, LEOTARDS, SLEEPWEAR, BRAS, CAMISOLES, LINGERIE, UNDERWEAR, HEADWEAR, HATS, HEADBANDS, BANDANAS, FOOTWEAR, BOOTS, SANDALS AND SLIPPERS (U.S. CLS. 22 AND 39).

GRETTA YAO, EXAMINING ATTORNEY

SN 85-152,163. GGFB, LLC, DBA GOLDEN GREEN, LOS ANGELES, CA. FILED 10-13-2010.

**LOCAL GREEN**

THE MARK CONSISTS OF STANDARD CHARACTERS WITHOUT CLAIM TO ANY PARTICULAR FONT, STYLE, SIZE, OR COLOR.

NO CLAIM IS MADE TO THE EXCLUSIVE RIGHT TO USE "GREEN", APART FROM THE MARK AS SHOWN.

FOR COLLARED SHIRTS; HOODED SWEAT SHIRTS; HOODED SWEATSHIRTS; JACKETS; KNIT SHIRTS; LONG-SLEEVED SHIRTS; OPEN-NECKED SHIRTS; PANTS; SHIRTS; SLACKS; SWEAT JACKETS; SWEAT PANTS; SWEAT SHIRTS; T-SHIRTS; TEE SHIRTS (U.S. CLS. 22 AND 39).

FIRST USE 7-1-2007; IN COMMERCE 7-1-2007.

STEVEN R. FINE, EXAMINING ATTORNEY

SN 85-153,236. MARR, HESTER, NSW, AUSTRALIA, AND MARR, JIM, NSW, AUSTRALIA, FILED 10-14-2010.

**TEMT&THINGS**

THE MARK CONSISTS OF STANDARD CHARACTERS WITHOUT CLAIM TO ANY PARTICULAR FONT, STYLE, SIZE, OR COLOR.

OWNER OF U.S. REG. NO. 3,373,071.

FOR CLOTHING FOR WOMEN AND GIRLS, NAMELY, TOPS, SHIRTS, T-SHIRTS, KNIT TOPS, HALTER TOPS, BLOUSES, SMOCK TOPS, SWEATERS, VESTS, BOTTOMS, PANTS, SHORTS, SKIRTS, SLACKS, SWEATPANTS, COATS, JACKETS, JUMPERS, CARDIGANS, DRESSES, SUITS, JUMP SUITS, SWIM WEAR, BELTS, GLOVES, RAINWEAR, SCARVES, SHAWLS, PONCHOS, MUFFLERS, SOCKS, TIGHTS, STOCKINGS, HOSIERY, LEGGINGS, LEOTARDS, SLEEPWEAR, BRAS, CAMISOLES, LINGERIE, UNDERWEAR, HEADWEAR, HATS, HEADBANDS, BANDANAS, FOOTWEAR, BOOTS, SANDALS AND SLIPPERS (U.S. CLS. 22 AND 39).

GRETTA YAO, EXAMINING ATTORNEY

**CLASS 25—(Continued).**

SN 85-153,424. ANTI BULL-E GEAR, LLC, FREDERICKSBURG, VA. FILED 10-15-2010.



THE COLOR(S) BLACK, WHITE, RED AND GRAY IS/ARE CLAIMED AS A FEATURE OF THE MARK.

THE MARK CONSISTS OF A BLACK SQUARE BOX CONTAINING A BLANK CROSS WORD PUZZLE GRID OF WHITE, BLACK AND GRAY. THE RED WORDING "CROSS WORDS" APPEARS AT THE TOP OF THE BOX AND THE WORD "SOLUTION" APPEARS IN WHITE SLANTED UNDERNEATH "CROSS WORDS".

FOR KNIT SHIRTS; LONG-SLEEVED SHIRTS; SHIRTS; SHIRTS AND SHORT-SLEEVED SHIRTS; SHIRTS FOR INFANTS, BABIES, TODDLERS AND CHILDREN; SHORT-SLEEVED OR LONG-SLEEVED T-SHIRTS; SHORT-SLEEVED SHIRTS; T-SHIRTS; TEE SHIRTS (U.S. CLS. 22 AND 39).

NELSON SNYDER, EXAMINING ATTORNEY

SN 85-153,562. HAYES, EREN, BATON ROUGE, LA. FILED 10-15-2010.



THE MARK CONSISTS OF A SCREAMING MONKEY WITH A PENCIL AND A DRIPPING PAINTBRUSH BEHIND BOTH EARS, WEARING ONE SMALL STUD EARRING IN EACH EAR. BELOW THERE IS THE STYLIZED TEXT "SCREAMING MONKEY ART".

FOR HOODED SWEATSHIRTS; JACKETS; PANTS; SHIRTS; SHOES (U.S. CLS. 22 AND 39).

BRENDAN REGAN, EXAMINING ATTORNEY

**CLASS 25—(Continued).**

SN 85-153,592. COSMOS SOCCER CLUB LLC, NEW YORK, NY. FILED 10-15-2010.

**COSMOS COUNTRY**

THE MARK CONSISTS OF STANDARD CHARACTERS WITHOUT CLAIM TO ANY PARTICULAR FONT, STYLE, SIZE, OR COLOR.

OWNER OF U.S. REG. NOS. 3,642,942, 3,642,950 AND OTHERS.

FOR APPAREL, NAMELY, CAPS AND HATS, SCARVES, T-SHIRTS (U.S. CLS. 22 AND 39).

MICHAEL TANNER, EXAMINING ATTORNEY

SN 85-154,100. KAYSER-ROTH CORPORATION, GREENSBORO, NC. FILED 10-15-2010.

**STYLE TO GO**

THE MARK CONSISTS OF STANDARD CHARACTERS WITHOUT CLAIM TO ANY PARTICULAR FONT, STYLE, SIZE, OR COLOR.

OWNER OF U.S. REG. NO. 3,389,553. FOR CLOTHING, NAMELY, HOSE AND SOCKS (U.S. CLS. 22 AND 39).

TINA MAI, EXAMINING ATTORNEY

SN 85-155,256. D'JOCK ENTERPRISES, SACHSE, TX. FILED 10-18-2010.

**DJOCK**

THE MARK CONSISTS OF STANDARD CHARACTERS WITHOUT CLAIM TO ANY PARTICULAR FONT, STYLE, SIZE, OR COLOR.

FOR CLOTHING, NAMELY, T-SHIRTS, SHIRTS, SWEATERS, SWEATSHIRTS, VESTS, JACKETS, COATS, PANTS, SHORTS, SKIRTS, SOCKS, HATS, CAPS; TENNIS WEAR; SWIMWEAR; FOOTWEAR (U.S. CLS. 22 AND 39).

PATRICIA EVANKO, EXAMINING ATTORNEY



**CLASS 25—(Continued).**

SN 85-155,442. LABEL+THREAD, INC., NEW YORK, NY. FILED 10-18-2010.

## LABEL+thread

THE MARK CONSISTS OF STANDARD CHARACTERS WITHOUT CLAIM TO ANY PARTICULAR FONT, STYLE, SIZE, OR COLOR.

FOR BLOUSES; BOTTOMS; COATS; DRESSES; JACKETS; KNITTED CAPS; KNITTED GLOVES; LEGGINGS; LOUNGE PANTS; PANTS; SCARVES; SHAWLS; SHIRTS; SKIRTS; SWEATERS; TOPS (U.S. CLS. 22 AND 39).

ANDREA HACK, EXAMINING ATTORNEY

SN 85-156,331. HAUTZA DESIGNS LLC, LEWISVILLE, TX. FILED 10-19-2010.

## Hautza Designs

THE MARK CONSISTS OF STANDARD CHARACTERS WITHOUT CLAIM TO ANY PARTICULAR FONT, STYLE, SIZE, OR COLOR.

NO CLAIM IS MADE TO THE EXCLUSIVE RIGHT TO USE "DESIGNS", APART FROM THE MARK AS SHOWN.

FOR APRONS (U.S. CLS. 22 AND 39).

FIRST USE 5-4-2010; IN COMMERCE 6-9-2010.

ALICE BENMAMAN, EXAMINING ATTORNEY

SN 85-156,461. DEANTEX, INC., GREAT NECK, NY. FILED 10-19-2010.

## VIA INDIGO

THE MARK CONSISTS OF STANDARD CHARACTERS WITHOUT CLAIM TO ANY PARTICULAR FONT, STYLE, SIZE, OR COLOR.

NO CLAIM IS MADE TO THE EXCLUSIVE RIGHT TO USE "INDIGO", APART FROM THE MARK AS SHOWN.

FOR SHIRTS, JACKETS, VESTS, HOODED PULL-OVERS, SWEATSHIRTS, SPORTS SHIRTS, POLO SHIRTS, T-SHIRTS, TANK TOPS, PANTS, KHAKIS, DENIMS, SHORTS (U.S. CLS. 22 AND 39).

IRA J. GOODSaid, EXAMINING ATTORNEY

**CLASS 25—(Continued).**

SN 85-156,527. ORIGINAL G., PUEBLO, CO. FILED 10-19-2010.



NO CLAIM IS MADE TO THE EXCLUSIVE RIGHT TO USE "ORIGINAL", APART FROM THE MARK AS SHOWN.

THE MARK CONSISTS OF THE WORDING "ORIGINAL G" IN STYLIZED FONT ALL WITHIN AN OVAL DESIGN. THE LETTER "G" APPEARS INSIDE A VERTICAL OVAL, WITH "ORIGINAL" WRITTEN ACROSS IT.

FOR BATHROBES; BELTS; COATS; DRESS SHIRTS; HATS; HOODED SWEATSHIRTS; JACKETS; JEANS; SHIRTS; SHOES; SOCKS; SUITS; SWEATPANTS; SWEATSHIRTS; T-SHIRTS; TANK TOPS; TIES; UNDERWEAR (U.S. CLS. 22 AND 39).

EMILY CHUO, EXAMINING ATTORNEY

SN 85-156,554. POUNDS, BRIAN B. OVIEDO, FL. FILED 10-19-2010.



NO CLAIM IS MADE TO THE EXCLUSIVE RIGHT TO USE "FISHING APPAREL", APART FROM THE MARK AS SHOWN.

THE MARK CONSISTS OF A STYLIZED "SA" POSITIONED BETWEEN TWO PUSH POLES, THE STYLIZED WORDING "SHALLOW ADDICTION" POSITIONED BETWEEN TWO PUSH POLES WITH A FLATS BOAT RESTING ABOVE THE TOP PUSH POLE AND FEATURING A STYLIZED "SA" IN THE BOTTOM RIGHT-HAND CORNER THEREOF. THE STYLIZED WORDING "FISHING APPAREL" IS POSITIONED BELOW THE BOTTOM PUSH POLE.

FOR BASEBALL CAPS AND HATS; CAP VISORS; FISHING SHIRTS; LONG-SLEEVED SHIRTS; MOISTURE-WICKING SPORTS SHIRTS; POLO SHIRTS; SHORT-SLEEVED OR LONG-SLEEVED T-SHIRTS; SHORT-SLEEVED SHIRTS; SUN VISORS; T-SHIRTS; TOBOGGAN HATS, PANTS AND CAPS (U.S. CLS. 22 AND 39).

BRIAN CALLAGHAN, EXAMINING ATTORNEY

**CLASS 25—(Continued).**

SN 85-156,783. HBI BRANDED APPAREL ENTERPRISES, LLC, WINSTON-SALEM, NC. FILED 10-20-2010.

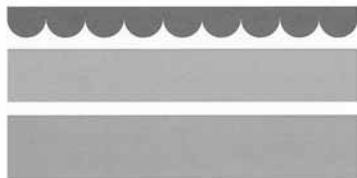

THE MARK CONSISTS OF A THREE LAYER DESIGN RESEMBLING A TWO-LAYER CAKE WITH ICING ON TOP. FOR BELTS FOR CLOTHING; BRAS; CAMISOLES; LEGGINGS; SCARVES; SKIRTS; TOPS (U.S. CLS. 22 AND 39).

TOBY BULLOFF, EXAMINING ATTORNEY

SN 85-156,786. HBI BRANDED APPAREL ENTERPRISES, LLC, WINSTON-SALEM, NC. FILED 10-20-2010.

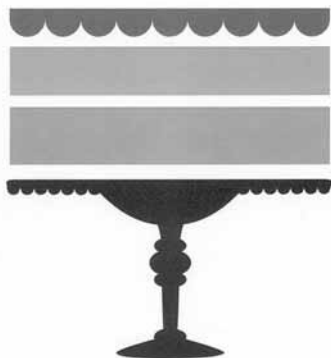

THE MARK CONSISTS OF A THREE LAYER DESIGN RESEMBLING A TWO-LAYER CAKE WITH ICING ON TOP, SITTING ON TOP OF A CAKE STAND.

FOR BELTS FOR CLOTHING; BRAS; CAMISOLES; LEGGINGS; SCARVES; SKIRTS; TOPS (U.S. CLS. 22 AND 39).

TOBY BULLOFF, EXAMINING ATTORNEY

SN 85-157,098. SCHONEMAN, CODY, CLEAR LAKE, IA. FILED 10-20-2010.

# Witard

THE MARK CONSISTS OF STANDARD CHARACTERS WITHOUT CLAIM TO ANY PARTICULAR FONT, STYLE, SIZE, OR COLOR.

FOR SHORT-SLEEVED OR LONG-SLEEVED T-SHIRTS (U.S. CLS. 22 AND 39).

DAVID YONTEF, EXAMINING ATTORNEY

**CLASS 25—(Continued).**

SN 85-158,526. SKILES RANDY W., WHEAT RIDGE, CO. FILED 10-21-2010.



THE MARK CONSISTS OF THE WORDING "RANSARD" IN STYLIZED FONT.

FOR POLO SHIRTS (U.S. CLS. 22 AND 39). FIRST USE 3-25-2010; IN COMMERCE 9-3-2010.

NICHOLAS ALTREE, EXAMINING ATTORNEY

SN 85-158,539. DUCDUC LLC, NEW YORK, NY. FILED 10-21-2010.

**THE NEW TRADITIONALISTS**

THE MARK CONSISTS OF STANDARD CHARACTERS WITHOUT CLAIM TO ANY PARTICULAR FONT, STYLE, SIZE, OR COLOR.

FOR COATS; FOOTWEAR; HEADGEAR, NAMELY, HATS AND CAPS; JACKETS; ONE PIECE GARMENT FOR INFANTS AND TODDLERS; PANTS; SHIRTS; SHORTS; SKIRTS AND DRESSES; SWEATSHIRTS; SWIMWEAR; UNDERWEAR (U.S. CLS. 22 AND 39).

LOURDES AYALA, EXAMINING ATTORNEY

SN 85-158,643. RELEFORD, BILL, LOS ANGELES, CA. FILED 10-22-2010.

**BLACK BARBERSHOP**

THE MARK CONSISTS OF STANDARD CHARACTERS WITHOUT CLAIM TO ANY PARTICULAR FONT, STYLE, SIZE, OR COLOR.

FOR FOOTWEAR AND CLOTHING, NAMELY, TOPS, BOTTOMS, SWEATSUITS, JOGGING SUITS, T-SHIRTS, UNDERWEAR, LOUNGEWEAR, SOCKS, ROBES, SHORTS, SOCKS, HATS, GLOVES, AND SHIRTS FOR MEN, WOMEN AND KIDS (U.S. CLS. 22 AND 39).

MICHAEL ENGEL, EXAMINING ATTORNEY

**CLASS 25—(Continued).**

SN 85-158,670. BOGART, MEGAN, ESTACADA, OR. FILED 10-22-2010.

## RAMPHEADS

THE MARK CONSISTS OF STANDARD CHARACTERS WITHOUT CLAIM TO ANY PARTICULAR FONT, STYLE, SIZE, OR COLOR.

FOR CLOTHING, NAMELY, T-SHIRTS, SWEAT-SHIRTS, KNIT SWEATERS, KNIT SHIRTS, KNIT PANTS, KNIT SOCKS, AND KNIT SKIRTS (U.S. CLS. 22 AND 39).

ELLEN B. AWRICH, EXAMINING ATTORNEY

SN 85-158,694. SANGUINE ENTERPRISES, LLC, SEVERNA PARK, MD. FILED 10-22-2010.



THE MARK CONSISTS OF STYLIZED LETTERS SPELLING OUT "THE POSITIVE SPIN". THE LETTER "O" IN THE WORD "POSITIVE" HAS A PLUS SYMBOL IN THE CENTER WITH AN ARROW STARTING FROM THE LEFT SIDE OF THE PLUS SYMBOL MOVING NORTH. THE LETTER "S" IN THE WORD "SPIN" HAS AN ARROW IN IT THAT FORMS THE LOWER HALF OF THE LETTER "S".

FOR BASEBALL CAPS AND HATS; BELTS; BELTS FOR CLOTHING; BELTS MADE OUT OF CLOTH; BOARD SHORTS; BODY SHIRTS; BOTTOMS; BOXER BRIEFS; BOXER SHORTS; BRIEFS; BUTTON DOWN SHIRTS; BUTTON-FRONT ALOHA SHIRTS; CAMOUFLAGE SHIRTS; CAMP SHIRTS; CHILDREN'S AND INFANTS' CLOTH BIBS; CHILDREN'S CLOTH EATING BIBS; CLOTH BIBS; CLOTH BIBS FOR ADULT DINERS; CLOTHING FOR ATHLETIC USE, NAMELY, PADDED ELBOW COMPRESSION SLEEVES BEING PART OF AN ATHLETIC GARMENT; CLOTHING FOR ATHLETIC USE, NAMELY, PADDED PANTS; CLOTHING FOR ATHLETIC USE, NAMELY, PADDED SHIRTS; CLOTHING FOR ATHLETIC USE, NAMELY, PADDED SHORTS; CLOTHING, NAMELY, BASE LAYERS; CLOTHING, NAMELY, KHAKIS; CLOTHING, NAMELY, NECK TUBES; COLLARED SHIRTS; DRESS SHIRTS; DUSTERS; EYESHADES; FIGURE SKATING CLOTHING, NAMELY, SHIRTS; FISHING SHIRTS; FLEECE SHORTS; GLOVES AS CLOTHING; GOLF PANTS, SHIRTS AND SKIRTS; GOLF SHIRTS; GOLF SHORTS; GYM SHORTS; HATS; HATS FOR INFANTS, BABIES, TODDLERS AND CHILDREN; HEADBANDS FOR CLOTHING; HEADGEAR, NAMELY, CAPS; HOODED SWEAT SHIRTS; HOODS; HUNTING SHIRTS; INFANT AND TODDLER ONE PIECE CLOTHING; JACKETS; JERSEYS; KNIT SHIRTS; KNITTED UNDERWEAR; LADIES' UNDERWEAR; LEATHER BELTS; LONG-SLEEVED SHIRTS; MEN'S UNDERWEAR; MOISTURE-WICKING SPORTS SHIRTS; MUFFLERS; OPEN-NECKED SHIRTS; OVER SHIRTS; PANTIES; PANTIES, SHORTS AND BRIEFS; PARTS OF CLOTHING, NAMELY, GUSSETS FOR TIGHTS, GUSSETS FOR STOCKINGS, GUSSETS FOR BATHING SUITS, GUSSETS FOR UNDERWEAR, GUSSETS FOR LEOTARDS AND GUSSETS FOR FOOTLETS; PERSPIRATION ABSORBENT UNDERWEAR CLOTH-

**CLASS 25—(Continued).**

ING; POLO SHIRTS; RAIN HATS; RUGBY SHIRTS; RUGBY SHORTS; SHIRTS; SHIRTS AND SHORT-SLEEVED SHIRTS; SHIRTS AND SLIPS; SHIRTS FOR INFANTS, BABIES, TODDLERS AND CHILDREN; SHIRTS FOR SUITS; SHORT SETS; SHORT-SLEEVED OR LONG-SLEEVED T-SHIRTS; SHORT-SLEEVED SHIRTS; SHOULDER WRAPS; SHOULDER WRAPS FOR CLOTHING; SLEEP SHIRTS; SMALL HATS; SPORT SHIRTS; SPORTS SHIRTS; SPORTS SHIRTS WITH SHORT SLEEVES; SWEAT SHIRTS; SWEAT SHORTS; T-SHIRTS; TEE SHIRTS; THERMAL UNDERWEAR; THONGS; TIES; TOPS; TRIATHLON CLOTHING, NAMELY, TRIATHLON TIGHTS, TRIATHLON SHORTS, TRIATHLON SINGLET, TRIATHLON SHIRTS, TRIATHLON SUITS; TURTLE NECK SHIRTS; UNDERWEAR; UNDERWEAR, NAMELY, BOY SHORTS; WEARABLE GARMENTS AND CLOTHING, NAMELY, SHIRTS; WIND SHIRTS; WOMEN'S HATS AND HOODS; WOMEN'S UNDERWEAR; WOOLLY HATS; WOVEN OR KNITTED UNDERWEAR; WRAPS; YOGA SHIRTS (U.S. CLS. 22 AND 39).

GRETCHEN ULRICH, EXAMINING ATTORNEY

SN 85-159,162. RYAN MASAJI ARAKAKI, MILILANI, HI. FILED 10-22-2010.

## Aloha Army

THE MARK CONSISTS OF STANDARD CHARACTERS WITHOUT CLAIM TO ANY PARTICULAR FONT, STYLE, SIZE, OR COLOR.

FOR MEN'S, WOMEN'S, AND CHILDREN'S CLOTHING, NAMELY, SHIRTS, T-SHIRTS, SHORTS, PANTS, AND CAPS (U.S. CLS. 22 AND 39).

FIRST USE 5-15-2004; IN COMMERCE 5-15-2004.  
GEOFFREY FOSDICK, EXAMINING ATTORNEY

**CLASS 25—(Continued).**

SN 85-159,169. LURIE, ZACHARY, CLAIRMONT, GA. FILED 10-22-2010.



THE MARK CONSISTS OF THE STYLIZED LETTERS "F" AND "C", IN BLOCK STYLE, WITH THE "C" CONNECTED TO THE LOWER RIGHT OF THE "F", AND THE TERM "FRITHCO" LOCATED INSIDE THE "C" AT THE BOTTOM OF THE TOP CURVE.

THE WORDING "FRITHCO" HAS NO MEANING IN A FOREIGN LANGUAGE.

FOR CLOTHING, NAMELY, T-SHIRTS, SHIRTS, SHORTS, PANTS, JEANS, JACKETS, TANK TOPS, DRESSES, SOCKS, HATS, BATHING SUITS, BELTS AND SHOES (U.S. CLS. 22 AND 39).

SALLY SHIH, EXAMINING ATTORNEY

SN 85-159,269. SAGA USA, LLC, NAPERVILLE, IL. FILED 10-22-2010.

## The Tie Bar

THE MARK CONSISTS OF STANDARD CHARACTERS WITHOUT CLAIM TO ANY PARTICULAR FONT, STYLE, SIZE, OR COLOR.

OWNER OF U.S. REG. NO. 3,253,292.

NO CLAIM IS MADE TO THE EXCLUSIVE RIGHT TO USE "TIE", APART FROM THE MARK AS SHOWN.

FOR NECKTIES (U.S. CLS. 22 AND 39).

FIRST USE 7-1-2004; IN COMMERCE 9-22-2004.

WILLIAM VERHOSEK, EXAMINING ATTORNEY

**CLASS 25—(Continued).**

SN 85-159,504. KAYSER-ROTH CORPORATION, GREENSBORO, NC. FILED 10-22-2010.

## PERFECT COMFORT

THE MARK CONSISTS OF STANDARD CHARACTERS WITHOUT CLAIM TO ANY PARTICULAR FONT, STYLE, SIZE, OR COLOR.

OWNER OF U.S. REG. NOS. 3,557,505 AND 3,687,031.

NO CLAIM IS MADE TO THE EXCLUSIVE RIGHT TO USE "COMFORT", APART FROM THE MARK AS SHOWN, FOR CLOTHING, NAMELY, SOCKS (U.S. CLS. 22 AND 39).

TINA MAI, EXAMINING ATTORNEY

SN 85-159,722. CHOU INVESTMENTS, INC., DBA JOY PEARL, BELLEVUE, WA. FILED 10-23-2010.

## Joy Pearl

THE MARK CONSISTS OF STANDARD CHARACTERS WITHOUT CLAIM TO ANY PARTICULAR FONT, STYLE, SIZE, OR COLOR.

THE NAME "JOY PEARL" DOES NOT IDENTIFY A LIVING INDIVIDUAL.

FOR BRAS; CAMISOLES; GARTER BELTS; LINGERIE; PAJAMAS; PANTIES; PANTIES, SHORTS AND BRIEFS; STRAPLESS BRAS; T-SHIRTS; TEDDIES; THONGS; UNDERGARMENTS (U.S. CLS. 22 AND 39).

GENE MACIOL, EXAMINING ATTORNEY

SN 85-159,865. ALLEN, DANIEL L., DBA HOOP BOSS CLOTHING, NORTH HOLLYWOOD, CA. AND CHUMAN, JEANNE M., DBA HOOP BOSS CLOTHING, NORTH HOLLYWOOD, CA. FILED 10-24-2010.

## HOOP BOSS

THE MARK CONSISTS OF STANDARD CHARACTERS WITHOUT CLAIM TO ANY PARTICULAR FONT, STYLE, SIZE, OR COLOR.

FOR CLOTHING, NAMELY, TEE SHIRTS, SHIRTS, JEANS, JACKETS, COATS, PANTS, HATS, SWEAT SHIRTS, SWEAT PANTS, DRESSES, SKIRTS, SOCKS, UNDERWEAR AND FOOTWEAR (U.S. CLS. 22 AND 39).

FIRST USE 9-29-2010; IN COMMERCE 10-5-2010.

CHERYL CLAYTON, EXAMINING ATTORNEY

**CLASS 25—(Continued).**

SN 85-161,124. ESTREICHER, WILLIAM REID, LAS VEGAS, NV. FILED 10-26-2010.

# SUTURE

THE MARK CONSISTS OF STANDARD CHARACTERS WITHOUT CLAIM TO ANY PARTICULAR FONT, STYLE, SIZE, OR COLOR.

FOR (BASED ON USE IN COMMERCE) ATHLETIC APPAREL, NAMELY, SHIRTS, PANTS, JACKETS, FOOTWEAR, HATS AND CAPS, ATHLETIC UNIFORMS; CLOTHING FOR WEAR IN JUDO PRACTICES; CLOTHING FOR WEAR IN WRESTLING GAMES; SHORT SETS; TOPS; WEARABLE GARMENTS AND CLOTHING, NAMELY, SHIRTS (BASED ON INTENT TO USE) ATHLETIC UNIFORMS; GLOVES AS CLOTHING; GLOVES FOR APPAREL; HOODS; JACKETS; JERSEYS (U.S. CLS. 22 AND 39).

FIRST USE 1-20-2010; IN COMMERCE 10-6-2010.  
LIEF MARTIN, EXAMINING ATTORNEY

SN 85-167,547. VEGETARIAM, SAN ANTONIO, TX. FILED 11-2-2010.

# VegetarIAM

THE MARK CONSISTS OF STANDARD CHARACTERS WITHOUT CLAIM TO ANY PARTICULAR FONT, STYLE, SIZE, OR COLOR.

OWNER OF U.S. REG. NO. 3,912,664.  
FOR ATHLETIC APPAREL, NAMELY, SHIRTS, PANTS, JACKETS, FOOTWEAR, HATS AND CAPS, ATHLETIC UNIFORMS; BASEBALL CAPS AND HATS; HATS; HOODED SWEATSHIRTS; SHOES; SHORT-SLEEVED OR LONG-SLEEVED T-SHIRTS; SWEATSHIRTS; T-SHIRTS; WRISTBANDS (U.S. CLS. 22 AND 39).

FIRST USE 4-1-2010; IN COMMERCE 4-1-2010.  
ELISSA GARBER KON, EXAMINING ATTORNEY

**CLASS 25—(Continued).**

SN 85-169,972. LOPEZ, SANTOS, PERTH AMBOY, NJ. FILED 11-5-2010.



THE MARK CONSISTS OF A STYLIZED EARTH, THE EARTH WRAPPED VERTICALLY BY A ROAD OR STREET. THE WORDING "STREETCONTENDERS" IS LOCATED ABOVE THE EARTH DESIGN, THE PHRASE "WHERE ARE ALL THESE CONTENDERS AND FIGHTERS COMING FROM" IS LOCATED TO THE LEFT OF THE EARTH; THE PHRASE "THE STREETS OF UNITED STATES AND AROUND THE WORLD" IS LOCATED TO THE RIGHT OF THE EARTH; AND THE WORDING "BOXING-MMA-FIGHTERS" APPEARS BELOW THE EARTH.

FOR CAPS; COATS; JACKETS; PANTS; SHIRTS; SHOES; SOCKS (U.S. CLS. 22 AND 39).

BARBARA RUTLAND, EXAMINING ATTORNEY

SN 85-172,043. BECKER, COURTNEY, FALLBROOK, CA. FILED 11-8-2010.



NO CLAIM IS MADE TO THE EXCLUSIVE RIGHT TO USE "AMERICAN", APART FROM THE MARK AS SHOWN.

THE MARK CONSISTS OF THE ARTISTIC RENDING OF A HORSESHOE WITH THE LETTERS "AP" APPEARING IN THE HORSESHOE. THE STYLIZED WORDS "AMERICAN PONY" APPEAR TO THE RIGHT OF THE AFOREMENTIONED HORSESHOE.

FOR CLOTHING, NAMELY, SHIRTS, TANK TOPS, SWEATSHIRTS, SWEATPANTS, JACKETS, COATS, GLOVES, MITTENS, HATS, BEANIES, THERMAL SHIRTS, SCARVES, PANTS, SHORTS, SKIRTS, DRESSES, SWIMWEAR, UNDERWEAR, BRAS, SLEEPWEAR, ROBES, HEADBANDS, AND BELTS; INFANT AND CHILDREN APPAREL, NAMELY, ONE PIECE GARMENTS (U.S. CLS. 22 AND 39).

FIRST USE 6-0-2010; IN COMMERCE 6-0-2010.  
DEZMONA MIZELLE, EXAMINING ATTORNEY

SN 85-172,439. RUSSELL B AUGER, AKA THE LAST OBGYN, CHICAGO, IL. FILED 11-9-2010.

# THE LAST OBGYN

THE MARK CONSISTS OF STANDARD CHARACTERS WITHOUT CLAIM TO ANY PARTICULAR FONT, STYLE, SIZE, OR COLOR.

FOR CAMP SHIRTS; T-SHIRTS (U.S. CLS. 22 AND 39).  
DAWN HAN, EXAMINING ATTORNEY

**CLASS 25—(Continued).**

SN 85-173,061. RECTEC, CLINTON TOWNSHIP, MI. FILED 11-9-2010.



THE MARK CONSISTS OF THE STYLIZED TEXT "RT EDGE".  
FOR JACKETS; PANTS; SHIRTS; SHORTS; SWEAT SHIRTS; T-SHIRTS (U.S. CLS. 22 AND 39).  
HENRY S. ZAK, EXAMINING ATTORNEY

**CLASS 25—(Continued).**

SN 85-173,262. MUSCAT, JOHN, TORONTO, ONTARIO, CANADA, FILED 11-10-2010.



THE MARK CONSISTS OF JOHN & JENN IN SCRIPTIVE FORM.  
FOR MEN'S AND WOMEN'S CLOTHING, NAMELY, COATS FOR DRESS AND BUSINESS WEAR, JACKETS FOR DRESS AND BUSINESS WEAR, SUITS, FASHION SWEATERS, SHIRTS, FASHION SWEATSHIRTS, SWEAT PANTS, VESTS, SHORTS, PANTS, TIES, BELTS, HATS, JEANS, FASHION T-SHIRTS, PONCHOS, RAINCOATS, OVERALLS, COVERALLS, TOPS, JOGGING SUITS, SWIMSUITS, SLEEPERS, UNDERWEAR, BATHROBES, BOXER SHORTS, SLEEPWEAR, SOCKS, FASHION SWEAT SUITS, SHOES, BOOTS, SANDALS, THONGS, OVERCOATS FOR DRESS AND BUSINESS WEAR, CARDIGANS FOR DRESS AND BUSINESS WEAR, NECKWEAR; WOMEN'S DRESSES, SKIRTS AND BLOUSES (U.S. CLS. 22 AND 39).  
STEVEN R. FINE, EXAMINING ATTORNEY

---

SN 85-173,173. SURE HONEST INTERNATIONAL LIMITED, LLC, NEW YORK, NY. FILED 11-10-2010.

**BLKSMTH**

THE MARK CONSISTS OF STANDARD CHARACTERS WITHOUT CLAIM TO ANY PARTICULAR FONT, STYLE, SIZE, OR COLOR.  
FOR JEANS (U.S. CLS. 22 AND 39).  
CHERYL CLAYTON, EXAMINING ATTORNEY

---

SN 85-173,354. SOLID STRUCTURES, COLBERT, WA. FILED 11-10-2010.

**SOLID STRUCTURES**

THE MARK CONSISTS OF STANDARD CHARACTERS WITHOUT CLAIM TO ANY PARTICULAR FONT, STYLE, SIZE, OR COLOR.  
FOR ATHLETIC SHOES; BASEBALL CAPS; BEANIES; BELTS; BOXER BRIEFS; BOXER SHORTS; BRAS; COATS; HATS; HOODED SWEAT SHIRTS; JACKETS; LONG UNDERWEAR; PANTIES; PANTS; SHIRTS; SHOES; SHORTS; SOCKS; SPORTS BRAS; SWEAT PANTS; SWEATERS; SWEATSHIRTS; TANK TOPS; TURTLENECKS; VESTS (U.S. CLS. 22 AND 39).  
RONALD AIKENS, EXAMINING ATTORNEY

**CLASS 25—(Continued).**

SN 85-173,361. WEEKS, JAVED J., FORT LAUDERDALE, FL. AND WEEKS, MARVA N., FORT LAUDERDALE, FL. FILED 11-10-2010.



THE MARK CONSISTS OF THE STYLIZED TEXT "IR-EP SKN ST.KITTS & NEVIS".

FOR BELTS; DRESSES; HATS; JACKETS; JEANS; ONE PIECE GARMENT FOR INFANTS AND TODDLERS; PANTS; SCARVES; SHORTS; SKIRTS; SOCKS; SWEATERS; SWEATSHIRTS; SWIMWEAR; T-SHIRTS; TIES; UNDERGARMENTS (U.S. CLS. 22 AND 39).

RONALD AIKENS, EXAMINING ATTORNEY

SN 85-173,492. TIMBERGHOST LAND COMPANY, L.L.C., MEDIAPOLIS, IA. FILED 11-10-2010.

**TIMBERGHOST**

THE MARK CONSISTS OF STANDARD CHARACTERS WITHOUT CLAIM TO ANY PARTICULAR FONT, STYLE, SIZE, OR COLOR.

OWNER OF U.S. REG. NOS. 2,439,519 AND 2,636,048.

FOR CLOTHING, NAMELY, SHIRTS, T-SHIRTS, TURTLENECKS, THERMAL TOPS, SWEATERS, HUNTING SUITS, JACKETS, PULLOVERS, NECK GAITERS, HATS AND BASEBALL CAPS (U.S. CLS. 22 AND 39).

FIRST USE 12-0-2000; IN COMMERCE 10-0-2001.

BRENDAN REGAN, EXAMINING ATTORNEY

SN 85-173,552. KB MEDIA GROUP, LLC, SAN FRANCISCO, CA. FILED 11-10-2010.

**KUSH COUTURE**

THE MARK CONSISTS OF STANDARD CHARACTERS WITHOUT CLAIM TO ANY PARTICULAR FONT, STYLE, SIZE, OR COLOR.

NO CLAIM IS MADE TO THE EXCLUSIVE RIGHT TO USE "COUTURE", APART FROM THE MARK AS SHOWN.

FOR (BASED ON USE IN COMMERCE) HATS; T-SHIRTS; TOPS (BASED ON INTENT TO USE) COATS; COLLARED SHIRTS; FOOTWEAR; OUTER JACKETS; PANTS; SHORTS; SPORT COATS; SWEAT JACKETS; SWEATPANTS; SWEATSHIRTS; UNDERWEAR; WIND-JACKETS (U.S. CLS. 22 AND 39).

FIRST USE 1-0-2008; IN COMMERCE 1-0-2008.

ANGELA DUONG, EXAMINING ATTORNEY

**CLASS 25—(Continued).**

SN 85-174,160. REIMAN, WARREN, BROOKLYN, NY. FILED 11-11-2010.

**SUBWAY BOWL**

THE MARK CONSISTS OF STANDARD CHARACTERS WITHOUT CLAIM TO ANY PARTICULAR FONT, STYLE, SIZE, OR COLOR.

FOR HATS, JACKETS, AND SHIRTS (U.S. CLS. 22 AND 39).

JILL C. ALT, EXAMINING ATTORNEY

SN 85-174,793. FALCON MOTORCYCLES, LLC, LOS ANGELES, CA. FILED 11-11-2010.



THE MARK CONSISTS OF A RECTANGLE CONTAINING TWO SMALLER RECTANGLES. INSIDE THE SMALLEST RECTANGLE IS A DIAMOND. INSIDE THE DIAMOND IS THE WORD 'FALCON' IN CAPITAL LETTERS. A TRIANGLE IS POINTING TO THE LEFT ON THE LEFT OF THE 'F' OF 'FALCON'. A TRIANGLE IS POINTING TO THE RIGHT OF THE 'N' OF 'FALCON'. THE WORD "HAND" IS TO THE TOP LEFT OF THE DIAMOND. THE WORD "MADE" IS TO THE TOP RIGHT OF THE DIAMOND. THE WORD "MOTOR" IS TO THE BOTTOM LEFT OF THE DIAMOND. THE WORD "CYCLES" IS TO THE BOTTOM RIGHT OF THE DIAMOND.

FOR APPAREL FOR DANCERS, NAMELY, TEE SHIRTS, SWEATSHIRTS, PANTS, LEGGINGS, SHORTS AND JACKETS; ATHLETIC APPAREL, NAMELY, SHIRTS, PANTS, JACKETS, FOOTWEAR, HATS AND CAPS, ATHLETIC UNIFORMS; BASEBALL CAPS AND HATS; BEANIES; BELTS; BELTS FOR CLOTHING; BOMBER JACKETS; BOOTS; BOTTOMS; BRIEFS; BUTTON DOWN SHIRTS; CANVAS SHOES; CAPS; CLOTH BIBS; CLOTH DIAPERS; CLOTHING SHIELDS, NAMELY, PADS APPLIED TO THE UNDERARMS OF SHIRTS, BLOUSES AND SWEATERS; CLOTHING, NAMELY, ARM WARMERS; CLOTHING, NAMELY, BASE LAYERS; CLOTHING, NAMELY, WRAP-AROUNDS; COATS; CREW NECK SWEATERS; DENIM JACKETS; DENIMS; DOWN JACKETS; DRESS SHIRTS; DRIVERS; FLEECE VESTS; FUR COATS AND JACKETS; FUR HATS; FUR JACKETS; GLOVES; GLOVES AS CLOTHING; GLOVES FOR APPAREL; HAT BANDS; HATS; HATS FOR INFANTS, BABIES, TODDLERS AND CHILDREN; HEADBANDS FOR CLOTHING; HEAVY JACKETS; HOODED SWEAT SHIRTS; HOODS; INSOLES; JACKET LINERS; JACKETS; JACKETS AND SOCKS; JERSEYS; KNIT JACKETS; KNIT SHIRTS; KNITTED GLOVES; KNITTED UNDERWEAR; LADIES' UNDERWEAR; LEATHER BELTS; LEATHER HATS; LEATHER JACKETS; LEATHER SHIRTS; LEATHER VESTS; LEG WARMERS; LEGGINGS; LIGHT-REFLECTING JACKETS; LONG JACKETS; LONG SLEEVED VESTS; LONG-SLEEVED SHIRTS; MEN'S AND WOMEN'S JACKETS, COATS, TROUSERS, VESTS; MEN'S UNDERWEAR; MOTORCYCLE GLOVES; MOTORCYCLE JACKETS; NIGHT SHIRTS; OPEN-NECKED SHIRTS; OUTDOOR GLOVES; OUTER JACKETS; OVER SHIRTS; PADDED JACKETS; PADDING JACKETS; PANTS; POLO KNIT TOPS; POLO SHIRTS; QUILTED VESTS; RAIN HATS; RAIN JACKETS; RAINPROOF JACKETS; REVERSIBLE

**CLASS 25—(Continued).**

JACKETS; RIDING GLOVES; RUGBY SHIRTS; SCARFS; SHELL JACKETS; SHIRTS; SHIRTS AND SHORT-SLEEVED SHIRTS; SHIRTS FOR INFANTS, BABIES, TODDLERS AND CHILDREN; SHOE SOLES; SHOE STRAPS; SHOES; SHORT-SLEEVED OR LONG-SLEEVED T-SHIRTS; SHORT-SLEEVED SHIRTS; SLEEP PANTS; SLEEP SHIRTS; SLEEVED OR SLEEVELESS JACKETS; SLEEVES WORN SEPARATE AND APART FROM BLOUSES, SHIRTS AND OTHER TOPS; SMOKING JACKETS; SPORT SHIRTS; SPORTS CAPS AND HATS; SPORTS SHIRTS; SPORTS SHIRTS WITH SHORT SLEEVES; SUEDE JACKETS; SWEAT BANDS; SWEAT JACKETS; SWEAT SHIRTS; SWEATERS; T-SHIRTS; TEE SHIRTS; THERMAL UNDERWEAR; TIES; TOPS; TRAVEL CLOTHING CONTAINED IN A PACKAGE COMPRISING REVERSIBLE JACKETS, PANTS, SKIRTS, TOPS AND A BELT OR SCARF; TURTLENECK SWEATERS; UNDERWEAR; V-NECK SWEATERS; VESTS; WEARABLE GARMENTS AND CLOTHING, NAMELY, SHIRTS; WIND RESISTANT JACKETS; WIND VESTS; WIND-JACKETS; WOMEN'S HATS AND HOODS; WOOLLY HATS; WOVEN OR KNITTED UNDERWEAR; WRAPS; YOGA SHIRTS (U.S. CLS. 22 AND 39).  
FIRST USE 11-1-2010; IN COMMERCE 11-1-2010.  
DAVID HOFFMAN, EXAMINING ATTORNEY

SN 85-174,939. KINARD, K. SCOTT, TEMPE, AZ. FILED 11-11-2010.

# TEMPEASY

THE MARK CONSISTS OF STANDARD CHARACTERS WITHOUT CLAIM TO ANY PARTICULAR FONT, STYLE, SIZE, OR COLOR.

FOR A-SHIRTS; APPAREL FOR DANCERS, NAMELY, TEE SHIRTS, SWEATSHIRTS, PANTS, LEGGINGS, SHORTS AND JACKETS; ATHLETIC APPAREL, NAMELY, SHIRTS, PANTS, JACKETS, FOOTWEAR, HATS AND CAPS, ATHLETIC UNIFORMS; BODY SHIRTS; BUTTON DOWN SHIRTS; BUTTON-FRONT ALOHA SHIRTS; CAMOUFLAGE SHIRTS; CAMP SHIRTS; CLOTHING FOR ATHLETIC USE, NAMELY, PADDED SHIRTS; CLOTHING FOR BABIES, TODDLERS AND CHILDREN, TREATED WITH FIRE AND HEAT RETARDANTS, NAMELY, PAJAMAS, JACKETS, SHIRTS, PANTS, JUMPERS; CLOTHING SHIELDS, NAMELY, PADS APPLIED TO THE UNDERARMS OF SHIRTS, BLOUSES AND SWEATERS; COLLARED SHIRTS; DRESS SHIRTS; FISHING SHIRTS; GOLF PANTS, SHIRTS AND SKIRTS; GOLF SHIRTS; HOODED SWEAT SHIRTS; HUNTING SHIRTS; KNIT SHIRTS; LEATHER SHIRTS; LONG-SLEEVED SHIRTS; MOISTURE-WICKING SPORTS SHIRTS; NIGHT SHIRTS; OPEN-NECKED SHIRTS; OVER SHIRTS; PIQUE SHIRTS; POLO SHIRTS; RUGBY SHIRTS; SCIENTIFIC AND TECHNOLOGICAL APPAREL, NAMELY, SHIRTS, PANTS, JACKETS, FOOTWEAR, HATS AND CAPS, UNIFORMS; SHIRT FRONTS; SHIRT YOKES; SHIRTS; SHIRTS AND SHORT-SLEEVED SHIRTS; SHIRTS AND SLIPS; SHIRTS FOR INFANTS, BABIES, TODDLERS AND CHILDREN; SHIRTS FOR SUITS; SHORT-SLEEVED OR LONG-SLEEVED T-SHIRTS; SHORT-SLEEVED SHIRTS; SLEEP SHIRTS; SLEEVES WORN SEPARATE AND APART FROM BLOUSES, SHIRTS AND OTHER TOPS; SPORT SHIRTS; SPORTS SHIRTS; SPORTS SHIRTS WITH SHORT SLEEVES; SWEAT SHIRTS; T-SHIRTS; TEE SHIRTS; TRIATHLON CLOTHING, NAMELY, TRIATHLON TIGHTS, TRIATHLON SHORTS, TRIATHLON SINGLET, TRIATHLON SHIRTS, TRIATHLON SUITS; TURTLE NECK SHIRTS; WEARABLE GARMENTS AND CLOTHING, NAMELY, SHIRTS; WIND SHIRTS; YOGA SHIRTS (U.S. CLS. 22 AND 39).

TAMARA FRAZIER, EXAMINING ATTORNEY

**CLASS 25—(Continued).**

SN 85-175,144. POLLOCK, KERRY, VANCOUVER, CANADA, FILED 11-12-2010.

# PUBLIC MYTH

THE MARK CONSISTS OF STANDARD CHARACTERS WITHOUT CLAIM TO ANY PARTICULAR FONT, STYLE, SIZE, OR COLOR.

FOR WOMEN'S AND MEN'S CLOTHING, NAMELY, TOPS, BOTTOMS, SHIRTS, T-SHIRTS, SWEATSHIRTS, SWEATPANTS, SHORTS, PANTS, JACKETS, COATS, DRESSES, SKIRTS, HATS, SOCKS, FOOTWEAR, SHOES, AND SANDALS (U.S. CLS. 22 AND 39).

FIRST USE 10-12-2006; IN COMMERCE 10-19-2006.  
MARK PILARO, EXAMINING ATTORNEY

SN 85-175,481. CARTER, RENEE, RHOME, TX. FILED 11-12-2010.

# NCN NEW CoLoR NATION

THE MARK CONSISTS OF STANDARD CHARACTERS WITHOUT CLAIM TO ANY PARTICULAR FONT, STYLE, SIZE, OR COLOR.

FOR T-SHIRTS (U.S. CLS. 22 AND 39).  
INGA ERVIN, EXAMINING ATTORNEY

SN 85-175,525. MANZELLA PRODUCTIONS, INC., BUFFALO, NY. FILED 11-12-2010.

# TOUCH TIP

THE MARK CONSISTS OF STANDARD CHARACTERS WITHOUT CLAIM TO ANY PARTICULAR FONT, STYLE, SIZE, OR COLOR.

FOR OUTDOOR GLOVES (U.S. CLS. 22 AND 39).  
SUNG IN, EXAMINING ATTORNEY



**CLASS 25—(Continued).**

SN 85-175,552. MILLER, NICHOLAS WALTER, MESA, AZ.  
FILED 11-12-2010.



THE MARK CONSISTS OF THE WORD ACHIEVE UNDER A STYLIZED A.  
FOR SHIRTS; T-SHIRTS (U.S. CLS. 22 AND 39).  
SOPHIA S. KIM, EXAMINING ATTORNEY

SN 85-175,577. CASS NEW YORK INC., NEW YORK, NY.  
FILED 11-12-2010.

## INFLECTION

THE MARK CONSISTS OF STANDARD CHARACTERS WITHOUT CLAIM TO ANY PARTICULAR FONT, STYLE, SIZE, OR COLOR.  
FOR BLOUSES; COATS; DRESSES; JACKETS; PANTS; SHIRTS; SKIRTS; SUITS; SWEATERS (U.S. CLS. 22 AND 39).  
SUNG IN, EXAMINING ATTORNEY

SN 85-175,752. PALETTA, GENO V, HENDERSON, NV.  
FILED 11-12-2010.

## SCRAPP

THE MARK CONSISTS OF STANDARD CHARACTERS WITHOUT CLAIM TO ANY PARTICULAR FONT, STYLE, SIZE, OR COLOR.  
FOR CLOTHING, NAMELY, SHIRTS, BEANIES, CAPS, FOOTWEAR, G-STRINGS, GLOVES, HATS, HOODED SWEAT SHIRTS, JACKETS, JERSEYS, LONG-SLEEVED SHIRTS, PANTS, POLO SHIRTS, SHOES, SHORT-SLEEVED OR LONG-SLEEVED T-SHIRTS, SHORTS, SKULL CAPS, T-SHIRTS, TANK TOPS, TEE SHIRTS, THONGS, UNDERWEAR; WAIST BELTS, WRISTBANDS (U.S. CLS. 22 AND 39).  
FIRST USE 6-1-2008; IN COMMERCE 6-15-2008.  
PATRICIA EVANKO, EXAMINING ATTORNEY

**CLASS 25—(Continued).**

SN 85-176,275. CHYSTOFAKI, MARIA, LOS ANGELES, CA.  
FILED 11-14-2010.

## GLOBAL WARMING<sup>+</sup>

THE MARK CONSISTS OF THE STYLIZED WORDING "GLOBAL WARMING" AND THE DEPICTION OF A "+" (PLUS) SIGN NEXT TO THE LAST LETTER OF THE WORD "WARMING".  
FOR CORSETS; DRESSES; PANTS; SARONGS; SHORTS; SKIRTS; TANK TOPS; TOPS (U.S. CLS. 22 AND 39).  
MICHAEL WEBSTER, EXAMINING ATTORNEY

SN 85-176,293. MCLEAN, JOHN, DBA TBJON, COQUITLAM BC, CANADA, FILED 11-14-2010.

## TBJON

THE MARK CONSISTS OF STANDARD CHARACTERS WITHOUT CLAIM TO ANY PARTICULAR FONT, STYLE, SIZE, OR COLOR.  
FOR APPAREL FOR DANCERS, NAMELY, TEE SHIRTS, SWEATSHIRTS, PANTS, LEGGINGS, SHORTS AND JACKETS; ATHLETIC APPAREL, NAMELY, SHIRTS, PANTS, JACKETS, FOOTWEAR, HATS AND CAPS, ATHLETIC UNIFORMS; PANTIES, SHORTS AND BRIEFS (U.S. CLS. 22 AND 39).  
FIRST USE 10-30-2010; IN COMMERCE 11-14-2010.  
TRICIA SONNEBORN, EXAMINING ATTORNEY

SN 85-176,561. T. TURNER & ASSOCIATES, INC., BIRMINGHAM, AL. FILED 11-15-2010.

## NICE PACKAGE

THE MARK CONSISTS OF STANDARD CHARACTERS WITHOUT CLAIM TO ANY PARTICULAR FONT, STYLE, SIZE, OR COLOR.  
FOR ROBES; SWIM WEAR; T-SHIRTS; UNDERWEAR (U.S. CLS. 22 AND 39).  
TOBY BULLOFF, EXAMINING ATTORNEY

**CLASS 25—(Continued).**

SN 85-176,586. WATSON, JEANMARIE, CHARLOTTE, NC.  
FILED 11-15-2010.

everything poops...

THE MARK CONSISTS OF STANDARD CHARACTERS WITHOUT CLAIM TO ANY PARTICULAR FONT, STYLE, SIZE, OR COLOR.

FOR INFANT AND TODDLER ONE PIECE CLOTHING; SWEAT SHIRTS; T-SHIRTS (U.S. CLS. 22 AND 39).  
FIRST USE 10-8-2010; IN COMMERCE 10-8-2010.  
CURTIS FRENCH, EXAMINING ATTORNEY

**CLASS 25—(Continued).**

SN 85-176,937. ROI GROUP, INC., NORTH RICHLAND HILLS, TX. FILED 11-15-2010.



THE MARK CONSISTS OF A CAPITALIZED "L", THEN A LOWERCASE "O V E". A TSHIRT MAKING UP THE "T", FOLLOWED BY THE LETTERS "H, O, S, E". A CAPITALIZED "S", FOLLOWED BY LOWERCASE LETTERS "H, I, R, T, S.COM".

FOR WEARABLE GARMENTS AND CLOTHING, NAMELY, SHIRTS (U.S. CLS. 22 AND 39).  
FIRST USE 8-29-2008; IN COMMERCE 8-29-2008.  
KATHERINE STOIDES, EXAMINING ATTORNEY

SN 85-176,731. VIA ENTERTAINMENT, LLC, LOS ANGELES, CA. FILED 11-15-2010.

DWIGHT TRASH

THE MARK CONSISTS OF STANDARD CHARACTERS WITHOUT CLAIM TO ANY PARTICULAR FONT, STYLE, SIZE, OR COLOR.

FOR HATS; JACKETS; JERSEYS; SHIRTS; SWEATSHIRTS; T-SHIRTS (U.S. CLS. 22 AND 39).  
C. DIONNE CLYBURN, EXAMINING ATTORNEY

SN 85-176,895. A & H SPORTSWEAR CO., INC., STOCKERTOWN, PA. FILED 11-15-2010.

MAINSTREAM

THE MARK CONSISTS OF STANDARD CHARACTERS WITHOUT CLAIM TO ANY PARTICULAR FONT, STYLE, SIZE, OR COLOR.

FOR COVERUPS; SWIMSUITS (U.S. CLS. 22 AND 39).  
FIRST USE 9-1-1971; IN COMMERCE 9-1-1971.  
DOMINIC FATHY, EXAMINING ATTORNEY

SN 85-177,027. MARK ARCHER, GAINESVILLE, FL. FILED 11-15-2010.

SATAN LIFE

THE MARK CONSISTS OF STANDARD CHARACTERS WITHOUT CLAIM TO ANY PARTICULAR FONT, STYLE, SIZE, OR COLOR.

FOR HOODED SWEAT SHIRTS; JACKETS; PANTS; SHORTS; SOCKS; SWEAT SHIRTS; T-SHIRTS; TANK TOPS; UNDERWEAR (U.S. CLS. 22 AND 39).  
MATTHEW EINSTEIN, EXAMINING ATTORNEY

SN 85-177,079. SPYDER ACTIVE SPORTS, INC., BOULDER, CO. FILED 11-15-2010.

POWDERAP

THE MARK CONSISTS OF STANDARD CHARACTERS WITHOUT CLAIM TO ANY PARTICULAR FONT, STYLE, SIZE, OR COLOR.

FOR CLOTHING, NAMELY PANTS AND GAITERS (U.S. CLS. 22 AND 39).  
REBECCA EISINGER, EXAMINING ATTORNEY

**CLASS 25—(Continued).**

SN 85-177,102. LIEDTKE, CHRISTINA A., NEW YORK, NY.  
FILED 11-15-2010.

**CHRISTIANA J. PAUL**

THE MARK CONSISTS OF STANDARD CHARACTERS WITHOUT CLAIM TO ANY PARTICULAR FONT, STYLE, SIZE, OR COLOR.

THE NAME(S), PORTRAIT(S), AND/OR SIGNATURE(S) SHOWN IN THE MARK DOES NOT IDENTIFY A PARTICULAR LIVING INDIVIDUAL.

FOR BALL GOWNS; BATHING SUITS; BELTS FOR CLOTHING; BIKINIS; BLAZERS; BLOUSES; CAMI-SOLES; CARDIGANS; COATS; CREW NECKS; DRESSES; EVENING DRESSES; EVENING GOWNS; GLOVES; GOWNS; LEGGINGS; PANTS; PULLOVERS; RAINWEAR; SCARVES; SHAWLS AND HEADSCARVES; SHIRTS; SHORTS; SKIRTS; SUITS; SWEATERS; T-SHIRTS; TANK TOPS; TIES; TOPS; TRENCH COATS; VESTS; WEDDING DRESSES; WEDDING GOWNS; WRAPS (U.S. CLS. 22 AND 39).

FIRST USE 4-1-2010; IN COMMERCE 4-1-2010.  
WON TEAK OH, EXAMINING ATTORNEY

SN 85-177,246. HOFFMAN, MARK, HUNTINGTON BEACH, CA. AND DECUIR, TOM, HUNTINGTON BEACH, CA.  
FILED 11-15-2010.

**Tommy Palapa**

THE MARK CONSISTS OF STANDARD CHARACTERS WITHOUT CLAIM TO ANY PARTICULAR FONT, STYLE, SIZE, OR COLOR.

THE NAME(S), PORTRAIT(S), AND/OR SIGNATURE(S) SHOWN IN THE MARK DOES NOT IDENTIFY A PARTICULAR LIVING INDIVIDUAL.

FOR HATS; SHIRTS (U.S. CLS. 22 AND 39).  
FIRST USE 9-10-2009; IN COMMERCE 9-10-2010.  
GEORGE LORENZO, EXAMINING ATTORNEY

SN 85-177,289. PARAMOUNT APPAREL LTD., NEW YORK, NY. FILED 11-15-2010.

**PEACE LOVE CHILL**

THE MARK CONSISTS OF STANDARD CHARACTERS WITHOUT CLAIM TO ANY PARTICULAR FONT, STYLE, SIZE, OR COLOR.

OWNER OF U.S. REG. NOS. 2,237,913, 2,920,007 AND 3,378,005.

FOR JACKETS (U.S. CLS. 22 AND 39).  
FIRST USE 11-30-2008; IN COMMERCE 8-31-2009.  
STEVEN JACKSON, EXAMINING ATTORNEY

**CLASS 25—(Continued).**

SN 85-177,298. ZUFFA, LLC, LAS VEGAS, NV. FILED 11-15-2010.

**CHICKEN MONSTER**

THE MARK CONSISTS OF STANDARD CHARACTERS WITHOUT CLAIM TO ANY PARTICULAR FONT, STYLE, SIZE, OR COLOR.

FOR BELTS; BOTTOMS; COATS; DRESSES; FOOTWEAR; GLOVES; HEADWEAR; JACKETS; LOUNGEWEAR; SCARVES; SLEEPWEAR; SOCKS; SWEATBANDS; SWIMWEAR; TOPS; UNDERGARMENTS; WARM UP SUITS (U.S. CLS. 22 AND 39).

ALICE BENMAMAN, EXAMINING ATTORNEY

SN 85-177,324. CALVIN HAMMOCK, DAVENPORT, IA.  
FILED 11-15-2010.

**Imit B**

THE MARK CONSISTS OF STANDARD CHARACTERS WITHOUT CLAIM TO ANY PARTICULAR FONT, STYLE, SIZE, OR COLOR.

FOR CLOTHING, NAMELY, SHIRTS, JACKETS, PANTS, JEANS, HATS, AND SHOES (U.S. CLS. 22 AND 39).

JOHN GARTNER, EXAMINING ATTORNEY

SN 85-177,385. THE KAYO CORP, CARLSBAD, CA. FILED 11-16-2010.

**USELESS EATERS**

THE MARK CONSISTS OF STANDARD CHARACTERS WITHOUT CLAIM TO ANY PARTICULAR FONT, STYLE, SIZE, OR COLOR.

FOR HEADWEAR; HOODS; MEN'S AND WOMEN'S JACKETS, COATS, TROUSERS, VESTS; T-SHIRTS (U.S. CLS. 22 AND 39).

KELLEY WELLS, EXAMINING ATTORNEY

**CLASS 25—(Continued).**

SN 85-177,417. SIFUENTES III, JOSE, CHULA VISTA, CA. FILED 11-16-2010.

**STRIVE2PERFECTION**

THE MARK CONSISTS OF STANDARD CHARACTERS WITHOUT CLAIM TO ANY PARTICULAR FONT, STYLE, SIZE, OR COLOR.

FOR CLOTHING, NAMELY, HATS, SHORTS, PANTS, SHORT-SLEEVED SHIRTS, LONG-SLEEVED SHIRTS, T-SHIRTS (U.S. CLS. 22 AND 39).

JENNIFER VASQUEZ, EXAMINING ATTORNEY

**CLASS 25—(Continued).**

SN 85-177,480. ROBERT G. SPALLER, CARMEL, IN. FILED 11-16-2010.

**3-D TALKING T**

THE MARK CONSISTS OF STANDARD CHARACTERS WITHOUT CLAIM TO ANY PARTICULAR FONT, STYLE, SIZE, OR COLOR.

FOR SHIRTS (U.S. CLS. 22 AND 39).

IRA J. GOODSaid, EXAMINING ATTORNEY

SN 85-177,427. GUZMAN-SANCHEZ, PAUL, CHATSWORTH, CA. FILED 11-16-2010.

**FULL MOUNT**

THE MARK CONSISTS OF STANDARD CHARACTERS WITHOUT CLAIM TO ANY PARTICULAR FONT, STYLE, SIZE, OR COLOR.

FOR CLOTHING, NAMELY, TOPS, BOTTOMS, T-SHIRTS, SWEATSHIRTS, SWEATPANTS, SWEATSUITS, SHORTS, PANTS, HATS, JACKETS, SWEATS, HEADWEAR, FOOTWEAR, WRIST BANDS, TANK TOPS, UNDERWEAR, SOCKS, BANDANAS AND BELTS (U.S. CLS. 22 AND 39).

SANI KHOURI, EXAMINING ATTORNEY

SN 85-177,513. BRIAN F. GREGORY, BOXFORD, MA. FILED 11-16-2010.

**Albagoose**

THE MARK CONSISTS OF STANDARD CHARACTERS WITHOUT CLAIM TO ANY PARTICULAR FONT, STYLE, SIZE, OR COLOR.

FOR SHIRTS, T-SHIRTS AND CAPS (U.S. CLS. 22 AND 39).

GRETТА YAO, EXAMINING ATTORNEY

SN 85-177,435. LEVASH, JACQUELINE, NORTH BRUNSWICK, NJ. FILED 11-16-2010.

**WASHY WASHY HAPPY HAPPY**

THE MARK CONSISTS OF STANDARD CHARACTERS WITHOUT CLAIM TO ANY PARTICULAR FONT, STYLE, SIZE, OR COLOR.

FOR CLOTHING, NAMELY, TEE SHIRTS (U.S. CLS. 22 AND 39).

JANET LEE, EXAMINING ATTORNEY

SN 85-177,542. T&A PRODUCTS LLC, DBA WELL HUNG VINEYARD, CHARLOTTESVILLE, VA. FILED 11-16-2010.

**Well Hung**

THE MARK CONSISTS OF STANDARD CHARACTERS WITHOUT CLAIM TO ANY PARTICULAR FONT, STYLE, SIZE, OR COLOR.

OWNER OF U.S. REG. NOS. 3,755,003, 3,911,608 AND 3,914,692.

FOR APRONS (U.S. CLS. 22 AND 39).

FIRST USE 6-1-2009; IN COMMERCE 6-1-2009.

TASNEEM HUSSAIN, EXAMINING ATTORNEY

**CLASS 25—(Continued).**

SN 85-177,591. HOOSULO, DBA CITY FABRIC, RALEIGH, NC. FILED 11-16-2010.



THE MARK CONSISTS OF THE WORDS "CITY" AND "FABRIC" JOINED TOGETHER; THE BLACK SPACES INSIDE THE LETTERS REPRESENT BUILDINGS OR PARCELS (AS WHEN LOOKING AT A MAP IN PLAN VIEW) AND THE WHITE SPACES REPRESENT STREETS OR OTHER VOIDS BETWEEN PARCELS.

FOR SHIRTS AND SHORT-SLEEVED SHIRTS (U.S. CLS. 22 AND 39).

FIRST USE 8-1-2010; IN COMMERCE 8-1-2010.

THEODORE MCBRIDE, EXAMINING ATTORNEY

**CLASS 25—(Continued).**

SN 85-177,733. BAYNES, BEVERLEY, CLINTON, MD. FILED 11-16-2010.



THE MARK CONSISTS OF A DRAWN APPLE WITH A HEART IN THE CENTER, WITH PARTIAL SKIN OF APPLE ON THE OUTSIDE.

FOR CAPS; TEE SHIRTS (U.S. CLS. 22 AND 39).

GEORGE LORENZO, EXAMINING ATTORNEY

SN 85-177,770. LUNA INTERNATIONAL U.S.A. INC., HAUPAUGE, NY. FILED 11-16-2010.

## TENDERTOES

THE MARK CONSISTS OF STANDARD CHARACTERS WITHOUT CLAIM TO ANY PARTICULAR FONT, STYLE, SIZE, OR COLOR.

FOR FOOTWEAR (U.S. CLS. 22 AND 39).

FIRST USE 1-1-1991; IN COMMERCE 1-1-1991.

TOBY BULLOFF, EXAMINING ATTORNEY

SN 85-177,674. ROMEO & JULIETTE, INC., CITRUS HEIGHTS, CA. FILED 11-16-2010.

## POWER OF THE PAW

THE MARK CONSISTS OF STANDARD CHARACTERS WITHOUT CLAIM TO ANY PARTICULAR FONT, STYLE, SIZE, OR COLOR.

FOR COATS FOR MEN AND WOMEN; FOOTWEAR; FOOTWEAR FOR MEN; FOOTWEAR FOR MEN AND WOMEN; GLOVES AS CLOTHING; HATS; LEATHER SHOES; LEISURE SHOES; MUFFLERS; PANTS; SHIRTS; SHIRTS AND SHORT-SLEEVED SHIRTS; SHOES; SHORT-SLEEVED SHIRTS; SPORT SHIRTS; SPORTS CAPS AND HATS; SWEAT PANTS; T-SHIRTS; WATER REPELLING FOOTWEAR; WEARABLE GARMENTS AND CLOTHING, NAMELY, SHIRTS; WOMEN'S HATS AND HOODS; WOMEN'S SHOES (U.S. CLS. 22 AND 39).

ELLEN PERKINS, EXAMINING ATTORNEY

SN 85-177,961. MORRISSEY THOMAS EDWARD, NEWPORT BEACH, CA. FILED 11-16-2010.

## Powder Puss

THE MARK CONSISTS OF STANDARD CHARACTERS WITHOUT CLAIM TO ANY PARTICULAR FONT, STYLE, SIZE, OR COLOR.

FOR ATHLETIC APPAREL, NAMELY, SHIRTS, PANTS, JACKETS, FOOTWEAR, HATS AND CAPS, ATHLETIC UNIFORMS; BEANIES; BOTTOMS; FLEECE TOPS; HOODED SWEATSHIRTS; LADIES' UNDERWEAR; LONG UNDERWEAR; PANTIES, SHORTS AND BRIEFS; PERSPIRATION ABSORBENT UNDERWEAR CLOTHING; SCARFS; SHIRTS AND SHORT-SLEEVED SHIRTS; SKI GLOVES; SKI JACKETS; SKI PANTS; SKI SUITS; SKI WEAR; SNOWBOARD GLOVES; SNOWBOARD JACKETS; SNOWBOARD MITTENS; SNOWBOARD PANTS; SWEATSHIRTS; T-SHIRTS; TANK TOPS; THERMAL UNDERWEAR; TOPS; TUBE TOPS (U.S. CLS. 22 AND 39).

MARGARET POWER, EXAMINING ATTORNEY

**CLASS 25—(Continued).**

SN 85-178,178. ETHICALLY ENGAGED YOUTH, INC., VAIL, CO. FILED 11-16-2010.

**STUDENTS SHOULDER TO SHOULDER**

THE MARK CONSISTS OF STANDARD CHARACTERS WITHOUT CLAIM TO ANY PARTICULAR FONT, STYLE, SIZE, OR COLOR.

FOR MEN'S, WOMEN'S AND CHILDREN'S CLOTHING AND OUTERWEAR, NAMELY, CAPS, WOOL HATS, PAINTERS CAPS, BASEBALL CAPS, VISORS, HEADBANDS, EAR MUFFS, BELTS, WRISTBANDS, T-SHIRTS, TANK TOPS, PAJAMAS, GOLF SHIRTS, SWEATERS, SWEATSHIRTS, JACKETS, NECKTIES, SUSPENDERS, CLOTH BIBS, JERSEYS, NIGHT SHIRTS, COATS, ROBES, RAINCOATS, PARKAS, PONCHOS, SNEAKERS, GLOVES, SCARVES, SNOW SUITS, SKI SUITS, SNOWBOARDING PANTS, SNOWBOARDING JACKETS, MITTENS, APRONS, DOWN JACKETS, LEATHER JACKETS, SHORTS, SWEATPANTS, JEANS, PANTS, KNICKERS, SOCKS, UNDERWEAR, AND BATHING SUITS; AND FOOTWEAR (U.S. CLS. 22 AND 39).

DOMINICK J. SALEMI, EXAMINING ATTORNEY

**CLASS 25—(Continued).**

SN 85-178,211. PELAYO, LUIS, LOS ANGELES, CA. FILED 11-16-2010.



THE MARK CONSISTS OF "ALEXANDER" IN STYLIZED FORM ALONG WITH A LOGO COMPRISED OF A STYLIZED ALPHA SYMBOL SUPERIMPOSED OVER A STYLIZED OMEGA SYMBOL.

FOR BEANIES; CAPS; FOOTWEAR; HATS; HOODED SWEAT SHIRTS; JEANS; LONG-SLEEVED SHIRTS; PANTS; PONCHOS; SHIRTS; SHORT-SLEEVED OR LONG-SLEEVED T-SHIRTS; SOCKS; SWEAT SHIRTS; SWEATPANTS; T-SHIRTS (U.S. CLS. 22 AND 39).

BRENDAN REGAN, EXAMINING ATTORNEY

SN 85-178,207. KATE LEXI DELLON, ALBERTSON, NY. FILED 11-16-2010.

**BREEZE**

THE MARK CONSISTS OF STANDARD CHARACTERS WITHOUT CLAIM TO ANY PARTICULAR FONT, STYLE, SIZE, OR COLOR.

FOR (BASED ON USE IN COMMERCE) T-SHIRTS(-BASED ON INTENT TO USE) JACKETS; SHIRTS; SHORTS; SWEAT SHIRTS; SWEATERS; SWIMSUITS (U.S. CLS. 22 AND 39).

FIRST USE 5-12-2010; IN COMMERCE 5-12-2010.

BRENDAN REGAN, EXAMINING ATTORNEY

SN 85-178,291. SR HOLDINGS, LLC, LEXINGTON, MA. FILED 11-16-2010.

**A PASSION FOR THE SEA**

THE MARK CONSISTS OF STANDARD CHARACTERS WITHOUT CLAIM TO ANY PARTICULAR FONT, STYLE, SIZE, OR COLOR.

FOR OUTERWEAR, NAMELY, JACKETS, PULL-OVERS, VESTS; SHIRTS, NAMELY, T-SHIRTS, POLO SHIRTS, LONG-SLEEVED T-SHIRTS, RUGBY SHIRTS, DRESS SHIRTS; SHORTS; SWIMMING SUITS; PANTS; HATS; BELTS; FOOTWEAR, NAMELY, SHOES, BOAT SHOES, SNEAKERS, BOOTS, SANDALS; FOUL WEATHER GEAR (U.S. CLS. 22 AND 39).

FIRST USE 2-0-2009; IN COMMERCE 2-0-2009.

JOHN DWYER, EXAMINING ATTORNEY

**CLASS 25—(Continued).**

SN 85-178,321. TONY COAKLEY, UPPER LAKE, CA. FILED 11-16-2010.

Live  
C.L.E.A.N!  
C. ompassionate & L. oving to  
E. veryone.  
A. bused by N. o one!

THE MARK CONSISTS OF STANDARD CHARACTERS WITHOUT CLAIM TO ANY PARTICULAR FONT, STYLE, SIZE, OR COLOR.

FOR ATHLETIC APPAREL, NAMELY, SHIRTS, PANTS, JACKETS, FOOTWEAR, HATS AND CAPS, ATHLETIC UNIFORMS (U.S. CLS. 22 AND 39).  
COLLEEN KEARNEY, EXAMINING ATTORNEY

SN 85-178,386. SCHMITZ, MARK, SALT LAKE CITY, UT. FILED 11-16-2010.

**AIBIRDTA**

THE MARK CONSISTS OF STANDARD CHARACTERS WITHOUT CLAIM TO ANY PARTICULAR FONT, STYLE, SIZE, OR COLOR.

FOR HATS; TEE SHIRTS (U.S. CLS. 22 AND 39).  
COLLEEN DOMBROW, EXAMINING ATTORNEY

**CLASS 25—(Continued).**

SN 85-178,469. NAMOWICZ, SCOTT E. DBA VENOM LACROSSE, LLC, TEGA CAY, SC. FILED 11-16-2010.



OWNER OF U.S. REG. NO. 3,689,140.  
THE MARK CONSISTS OF THE IMAGE OF A LACROSSE HEAD WITH SPIDER LIKE ATTRIBUTES.

FOR ANKLE SOCKS; ANKLETS; ATHLETIC APPAREL, NAMELY, SHIRTS, PANTS, JACKETS, FOOTWEAR, HATS AND CAPS, ATHLETIC UNIFORMS; ATHLETIC UNIFORMS; BASEBALL CAPS AND HATS; BOOTS FOR SPORT; CLEATS FOR ATTACHMENT TO SPORTS SHOES; CLOTHING FOR ATHLETIC USE, NAMELY, PADDED ELBOW COMPRESSION SLEEVES BEING PART OF AN ATHLETIC GARMENT; CLOTHING FOR ATHLETIC USE, NAMELY, PADDED PANTS; CLOTHING FOR ATHLETIC USE, NAMELY, PADDED SHIRTS; CLOTHING FOR ATHLETIC USE, NAMELY, PADDED SHORTS; CLOTHING FOR WEAR IN WRESTLING GAMES; CLOTHING, NAMELY, ARM WARMERS; CLOTHING, NAMELY, ATHLETIC SLEEVES; CLOTHING, NAMELY, BASE LAYERS; COMBATIVE SPORTS UNIFORMS; FOOTWEAR NOT FOR SPORTS; GLOVES AS CLOTHING; GLOVES FOR APPAREL; HATS; HOODS; JACKETS; JERSEYS; LEATHER BELTS; MOISTURE-WICKING SPORTS BRAS; MOISTURE-WICKING SPORTS PANTS; MOISTURE-WICKING SPORTS SHIRTS; PERSPIRATION ABSORBENT UNDERWEAR CLOTHING; PINNIES IN THE NATURE OF SCRIMMAGE VESTS FOR USE IN SPORTS; SOCKS; SPORT COATS; SPORT SHIRTS; SPORT STOCKINGS; SPORTS BRA; SPORTS BRAS; SPORTS CAPS AND HATS; SPORTS JACKETS; SPORTS JERSEYS; SPORTS JERSEYS AND BREECHES FOR SPORTS; SPORTS OVER UNIFORMS; SPORTS OVERUNIFORMS; SPORTS PANTS; SPORTS SHIRTS; SPORTS SHIRTS WITH SHORT SLEEVES; SPORTS VESTS; THERMAL SOCKS; TRIATHLON CLOTHING, NAMELY, TRIATHLON TIGHTS, TRIATHLON SHORTS, TRIATHLON SINGLET, TRIATHLON SHIRTS, TRIATHLON SUITS; WATER SOCKS; WOMEN'S HATS AND HOODS (U.S. CLS. 22 AND 39).

FIRST USE 1-1-2009; IN COMMERCE 1-1-2009.  
CAROLYN CATALDO, EXAMINING ATTORNEY

SN 85-178,476. DON'T HARSH MY MELLOW, LLC, DELRAY BEACH, FL. FILED 11-16-2010.

**Brooklyn Without Limits**

THE MARK CONSISTS OF STANDARD CHARACTERS WITHOUT CLAIM TO ANY PARTICULAR FONT, STYLE, SIZE, OR COLOR.

FOR ATHLETIC APPAREL, NAMELY, SHIRTS, PANTS, JACKETS, FOOTWEAR, HATS AND CAPS, ATHLETIC UNIFORMS; JEANS (U.S. CLS. 22 AND 39).  
LINDA POWELL, EXAMINING ATTORNEY

**CLASS 25—(Continued).**

SN 85-178,697. SRL, LLC, LEXINGTON, MA. FILED 11-17-2010.



THE MARK CONSISTS OF A SQUARE CHECKERED FLAG APPEARING TO THE LEFT OF A STYLIZED UPPER CASE LETTER "V".

FOR FOOTWEAR (U.S. CLS. 22 AND 39).  
CARYN GLASSER, EXAMINING ATTORNEY

SN 85-178,748. SIT PRETTY AND SMILE, LOS ANGELES, CA. FILED 11-17-2010.

## Sit Pretty and Smile

THE MARK CONSISTS OF STANDARD CHARACTERS WITHOUT CLAIM TO ANY PARTICULAR FONT, STYLE, SIZE, OR COLOR.

FOR DRESSES; HATS; PANTS; SKIRTS; SWIMWEAR; TOPS (U.S. CLS. 22 AND 39).  
FRANK LATTUCA, EXAMINING ATTORNEY

SN 85-178,777. OGDEN, MARK, IDAHO FALLS, ID. FILED 11-17-2010.

## APPLIED VIOLENCE

THE MARK CONSISTS OF STANDARD CHARACTERS WITHOUT CLAIM TO ANY PARTICULAR FONT, STYLE, SIZE, OR COLOR.

FOR BEANIES; HATS; JACKETS; MARTIAL ARTS UNIFORMS; PANTS; SHOES; SHORTS; SWEATERS; T-SHIRTS (U.S. CLS. 22 AND 39).

KATHERINE STOIDES, EXAMINING ATTORNEY

**CLASS 25—(Continued).**

SN 85-178,791. OTS INDUSTRIES, LTD., GREENVILLE, NC. FILED 11-17-2010.

## THE OTHER TEAM SUCKS

THE MARK CONSISTS OF STANDARD CHARACTERS WITHOUT CLAIM TO ANY PARTICULAR FONT, STYLE, SIZE, OR COLOR.

FOR (BASED ON USE IN COMMERCE) SHIRTS; SHORT-SLEEVED OR LONG-SLEEVED T-SHIRTS-(BASED ON INTENT TO USE) CAPS; HATS; SWEATPANTS; SWEATSHIRTS; T-SHIRTS; TANK TOPS (U.S. CLS. 22 AND 39).

FIRST USE 8-0-2008; IN COMMERCE 8-29-2008.  
KATHERINE STOIDES, EXAMINING ATTORNEY

SN 85-178,915. GOLDEN, BRIAN, ROCKVILLE, MD. FILED 11-17-2010.

## PIPE CITY

THE MARK CONSISTS OF STANDARD CHARACTERS WITHOUT CLAIM TO ANY PARTICULAR FONT, STYLE, SIZE, OR COLOR.

FOR CLOTHING, NAMELY CAPS, HATS, KNITTED HEADWEAR, SHIRTS, T-SHIRTS, TANK TOPS, SWEATERS, SHORTS, PANTS, SKIRTS, ATHLETIC TEAM UNIFORMS, JERSEYS, WARM-UP SUITS, JOGGING SUITS, SWEATSHIRTS, SWEATPANTS, UNDERWEAR, BOXER SHORTS, JACKETS, WRISTBANDS, FOOTWEAR, SOCKS (U.S. CLS. 22 AND 39).

DORITT L. CARROLL, EXAMINING ATTORNEY

SN 85-179,114. KALINSKY, STUART, NEW YORK, NY. FILED 11-17-2010.

## EXERCISE YOUR FEET ONE "TOE" AT A TIME

THE MARK CONSISTS OF STANDARD CHARACTERS WITHOUT CLAIM TO ANY PARTICULAR FONT, STYLE, SIZE, OR COLOR.

FOR FOOTWEAR; SANDALS AND SLIPPERS (U.S. CLS. 22 AND 39).

HEATHER BIDDULPH, EXAMINING ATTORNEY



**CLASS 25—(Continued).**

SN 85-179,169. MACNEIL IP LLC, BOLINGBROOK, IL. FILED 11-17-2010.

# STARBELT

THE MARK CONSISTS OF STANDARD CHARACTERS WITHOUT CLAIM TO ANY PARTICULAR FONT, STYLE, SIZE, OR COLOR.  
FOR BELTS FOR CLOTHING (U.S. CLS. 22 AND 39).  
CAROLINE WOOD, EXAMINING ATTORNEY

**CLASS 25—(Continued).**

SN 85-179,316. HANK & JOJO, LLC, BROOKLYN, NY. FILED 11-17-2010.

# Hank & JoJo

THE MARK CONSISTS OF STANDARD CHARACTERS WITHOUT CLAIM TO ANY PARTICULAR FONT, STYLE, SIZE, OR COLOR.  
FOR HATS; ONE PIECE GARMENT FOR INFANTS AND TODDLERS; SOCKS; T-SHIRTS (U.S. CLS. 22 AND 39).  
FIRST USE 1-21-2009; IN COMMERCE 1-21-2009.  
NICHOLAS ALTREE, EXAMINING ATTORNEY

SN 85-179,213. HIGHDEAS, LLC, TROY, MI. FILED 11-17-2010.

# highDEAS

THE MARK CONSISTS OF STANDARD CHARACTERS WITHOUT CLAIM TO ANY PARTICULAR FONT, STYLE, SIZE, OR COLOR.  
FOR SHORT-SLEEVED OR LONG-SLEEVED T-SHIRTS (U.S. CLS. 22 AND 39).  
FIRST USE 9-28-2008; IN COMMERCE 1-15-2009.  
RENEE MCCRAY, EXAMINING ATTORNEY

SN 85-179,437. JAAD IMPORTS, LLC, FLORHAM PARK, NJ. FILED 11-17-2010.

# LILIANA

SN 85-179,303. KLINE, BRANDON, RICHMOND, VA. FILED 11-17-2010.



THE MARK CONSISTS OF A FLAGSTICK WITH A REPRESENTATION OF THE WORLD WAVING FROM IT.  
FOR CLOTHING, NAMELY, SHIRTS, HATS, BELTS, LOUNGE PANTS, TIES, SANDALS, BEACH SHOES (U.S. CLS. 22 AND 39).  
FIRST USE 7-30-2003; IN COMMERCE 2-18-2010.  
TRACY CROSS, EXAMINING ATTORNEY

THE MARK CONSISTS OF STANDARD CHARACTERS WITHOUT CLAIM TO ANY PARTICULAR FONT, STYLE, SIZE, OR COLOR.  
FOR WOMEN'S APPAREL, NAMELY, DRESSES, BLOUSES, SKIRTS, SWEATERS, PANTS, JACKETS AND VESTS (U.S. CLS. 22 AND 39).  
FIRST USE 1-19-2010; IN COMMERCE 1-19-2010.  
KATINA MISTER, EXAMINING ATTORNEY

**CLASS 25—(Continued).**

SN 85-179,446. KVM INTERNATIONAL FASHIONS LTD.,  
DBA ANAR, LOS ANGELES, CA. FILED 11-17-2010.

# Anar

THE MARK CONSISTS OF STANDARD CHARACTERS WITHOUT CLAIM TO ANY PARTICULAR FONT, STYLE, SIZE, OR COLOR.

FOR APPAREL FOR DANCERS, NAMELY, TEE SHIRTS, SWEATSHIRTS, PANTS, LEGGINGS, SHORTS AND JACKETS; ATHLETIC APPAREL, NAMELY, SHIRTS, PANTS, JACKETS, FOOTWEAR, HATS AND CAPS, ATHLETIC UNIFORMS; BATHING COSTUMES FOR WOMEN; CHILDREN'S AND INFANT'S APPAREL, NAMELY, JUMPERS, OVERALL SLEEPWEAR, PAJAMAS, ROMPERS AND ONE-PIECE GARMENTS; CHILDREN'S AND INFANTS' APPAREL TREATED WITH FIRE AND HEAT RETARDANTS, NAMELY, JUMPERS, OVERALL SLEEPWEAR, PAJAMAS, ROMPERS AND ONE-PIECE GARMENTS; COATS FOR MEN AND WOMEN; CUSTOM MADE TO MEASURE SUITS FOR MEN AND WOMEN; FOOTWEAR FOR MEN AND WOMEN; FOOTWEAR FOR WOMEN; GLOVES FOR APPAREL; LEOTARDS AND TIGHTS FOR WOMEN, MEN AND CHILDREN OF NYLON, COTTON OR OTHER TEXTILE FIBERS; MEN'S AND WOMEN'S JACKETS, COATS, TROUSERS, VESTS; MEN'S SUITS, WOMEN'S SUITS; SCIENTIFIC AND TECHNOLOGICAL APPAREL, NAMELY, SHIRTS, PANTS, JACKETS, FOOTWEAR, HATS AND CAPS, UNIFORMS; SUSPENDER BELTS FOR WOMEN; VISCOUS GEL POLYMER SOLD AS A COMPONENT OF FINISHED CUSTOM CUSHIONED FOOTWEAR FOR NON-ORTHOPEDIC PURPOSES AND APPAREL; WOMEN'S ATHLETIC TOPS WITH BUILT-IN BRAS; WOMEN'S CEREMONIAL DRESSES; WOMEN'S FOLDABLE SLIPPERS; WOMEN'S HATS AND HOODS; WOMEN'S SHOES; WOMEN'S SHOES, NAMELY, FOLDABLE FLATS; WOMEN'S TOPS, NAMELY, CAMIS; WOMEN'S UNDERWEAR (U.S. CLS. 22 AND 39).

JOHN HWANG, EXAMINING ATTORNEY

SN 85-179,606. GEM TRADING COMPANY, LLC, GIBSONVILLE, NC. FILED 11-18-2010.

# dbdewbusters

THE MARK CONSISTS OF STANDARD CHARACTERS WITHOUT CLAIM TO ANY PARTICULAR FONT, STYLE, SIZE, OR COLOR.

FOR CLOTHING, NAMELY, SOCKS, GLOVES, HATS AND TEE SHIRTS (U.S. CLS. 22 AND 39).

KRISTIN CARLSON, EXAMINING ATTORNEY

**CLASS 25—(Continued).**

SN 85-179,736. ATT INTERNATIONAL FOOTWEAR, INC., S. EL MONTE, CA. FILED 11-18-2010.

# EVA OZ

THE MARK CONSISTS OF STANDARD CHARACTERS WITHOUT CLAIM TO ANY PARTICULAR FONT, STYLE, SIZE, OR COLOR.

FOR COATS; DRESSES; FOOTWEAR; HEADWEAR; PAJAMAS; PANTS; SHIRTS; SHORT-SLEEVED OR LONG-SLEEVED T-SHIRTS; SHORT-SLEEVED SHIRTS; SHORTS; SWEAT PANTS; SWEATERS; SWEATPANTS; T-SHIRTS; TANK TOPS; TANK-TOPS; TEE SHIRTS; TOP COATS; TOPS (U.S. CLS. 22 AND 39).

CHRISTINE MARTIN, EXAMINING ATTORNEY

SN 85-179,801. ELMENDORF, CRAIG, RINGGOLD, GA.  
FILED 11-18-2010.

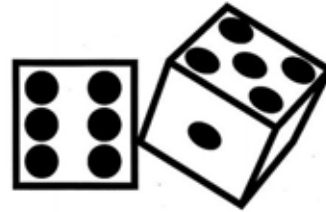

THE MARK CONSISTS OF TWO DICE, ONE DIE FACING VIEWER SHOWING SIX DOTS, ONE DIE SHOWING THREE SIDES WITH ONE SIDE SHOWING FIVE DOTS, ONE SIDE SHOWING ONE DOT (THE THIRD SIDE SHOWS NO DOTS).

FOR HATS; SHIRTS (U.S. CLS. 22 AND 39).

FIRST USE 6-1-1999; IN COMMERCE 6-1-1999.

PATRICIA EVANKO, EXAMINING ATTORNEY

SN 85-179,898. GAMEDAY BOOT COMPANY, LLC, AUSTIN, TX. FILED 11-18-2010.

# GAMEDAY BOOTS

THE MARK CONSISTS OF STANDARD CHARACTERS WITHOUT CLAIM TO ANY PARTICULAR FONT, STYLE, SIZE, OR COLOR.

NO CLAIM IS MADE TO THE EXCLUSIVE RIGHT TO USE "BOOTS", APART FROM THE MARK AS SHOWN.

FOR FOOTWEAR, NAMELY, BOOTS (U.S. CLS. 22 AND 39).

HELENE LIWINSKI, EXAMINING ATTORNEY

**CLASS 25—(Continued).**

SN 85-179,940. SOXLAND INTERNATIONAL, INC., JERSEY CITY, NJ. FILED 11-18-2010.

# FRĒZŌN

THE MARK CONSISTS OF STANDARD CHARACTERS WITHOUT CLAIM TO ANY PARTICULAR FONT, STYLE, SIZE, OR COLOR.

THE WORDING "FREZON" HAS NO MEANING IN A FOREIGN LANGUAGE.

FOR HOSIERY; UNDERGARMENTS (U.S. CLS. 22 AND 39).

GISELLE AGOSTO, EXAMINING ATTORNEY

SN 85-179,960. JOSH SUHRE DESIGN, LLC, CINCINNATI, OH. FILED 11-18-2010.

# ENAI

THE MARK CONSISTS OF STANDARD CHARACTERS WITHOUT CLAIM TO ANY PARTICULAR FONT, STYLE, SIZE, OR COLOR.

FOR BELTS; CAPS; FOOTWEAR; GLOVES; HATS; JACKETS; PANTS; SHIRTS; SHOES; SOCKS; SWEAT SHIRTS (U.S. CLS. 22 AND 39).

TEJBIR SINGH, EXAMINING ATTORNEY

SN 85-179,991. HEMISPHERE WORLDWIDE SALES, INC., MIAMI, FL. FILED 11-18-2010.



OWNER OF U.S. REG. NO. 2,257,583.

THE MARK CONSISTS OF A BEAR DESIGN WITH THE WORDS "TEDDY BOOM" ON THE BELLY OF THE BEAR.

FOR CHILDREN'S CLOTHING, NAMELY, SOCKS, SHOES, UNDERWEAR, SHORTS, PANTS, BELTS AND SUSPENDERS, DRESSES, HOSIERY, SLACKS, BLOUSES, SKIRTS, LAYETTES, CREEPERS (U.S. CLS. 22 AND 39).

FIRST USE 10-1-2008; IN COMMERCE 10-1-2008.

COLLEEN DOMBROW, EXAMINING ATTORNEY

**CLASS 25—(Continued).**

SN 85-180,021. LICHINE, CAROLINE, AIX EN PROVENCE, FRANCE, FILED 11-18-2010.



OWNER OF FRANCE REG. NO. 093643121, DATED 4-9-2009, EXPIRES 4-9-2019.

THE COLOR(S) PINK AND BLACK IS/ARE CLAIMED AS A FEATURE OF THE MARK.

THE MARK CONSISTS OF A STYLIZED SHORT DESIGN. THE SHORT IS BORDERED BY DOTS. THE COLOR PINK APPEARS IN THE SHORT DESIGN. THE COLOR BLACK APPEARS IN THE DOTS.

FOR CLOTHING, NAMELY, T-SHIRTS, SWEATSHIRTS, BERMUDAS AND PANTS (U.S. CLS. 22 AND 39).

MIDGE BUTLER, EXAMINING ATTORNEY

SN 85-180,073. ROMANE FRAGRANCES LLC, ELMHURST, IL. FILED 11-18-2010.

# COWGIRL CHIC

THE MARK CONSISTS OF STANDARD CHARACTERS WITHOUT CLAIM TO ANY PARTICULAR FONT, STYLE, SIZE, OR COLOR.

OWNER OF U.S. REG. NO. 3,329,487. FOR HEADWEAR; JACKETS; PANTS; SHIRTS (U.S. CLS. 22 AND 39).

ROBERT STRUCK, EXAMINING ATTORNEY

SN 85-180,143. FRIENDZ OF FAILURE, LLC, LOUISVILLE, KY. FILED 11-18-2010.

# FRIEND OF FAILURE

THE MARK CONSISTS OF STANDARD CHARACTERS WITHOUT CLAIM TO ANY PARTICULAR FONT, STYLE, SIZE, OR COLOR.

FOR CLOTHING, NAMELY SHIRTS, T-SHIRTS, SWEATSHIRTS, SWEATPANTS, JOGGING SUITS, JOGGING PANTS, PANTS, SHORTS, TOPS, BOTTOMS, SKIRTS, DRESSES, BOXER SHORTS, UNDERWEAR, SWEATERS, COATS, JACKETS; CLOTHING ACCESSORIES, NAMELY SCARVES, HEADBANDS, SOCKS, FOOTWEAR; HEADWEAR (U.S. CLS. 22 AND 39).

FIRST USE 12-31-2009; IN COMMERCE 12-31-2009.

NICHOLAS ALTREE, EXAMINING ATTORNEY

**CLASS 25—(Continued).**

SN 85-180,330. EVEREADY BATTERY COMPANY, INC., ST. LOUIS, MO. FILED 11-18-2010.



OWNER OF U.S. REG. NOS. 785,111, 3,057,746 AND OTHERS.

THE MARK CONSISTS OF A CAT JUMPING THROUGH THE NUMERICAL NUMBER "9" (NINE).

FOR FLEECE PULLOVERS; FLEECE TOPS; HALTER TOPS; HOODED PULLOVERS; HOODED SWEATSHIRTS; INFANT AND TODDLER ONE PIECE CLOTHING; KNIT SHIRTS; KNIT TOPS; SWEATSHIRTS; T-SHIRTS (U.S. CLS. 22 AND 39).

GEORGE LORENZO, EXAMINING ATTORNEY

SN 85-180,445. RICARDO VIZCAINO, LOS ANGELES, CA. AND OROSMAN VIZCAINO, JR., LOS ANGELES, CA. FILED 11-18-2010.

## LUXE SOCIETY

THE MARK CONSISTS OF STANDARD CHARACTERS WITHOUT CLAIM TO ANY PARTICULAR FONT, STYLE, SIZE, OR COLOR.

FOR CLOTHING, NAMELY, JEANS, SHIRTS, SHORTS, SKIRTS, DRESSES, PANTS, COATS, TOPS AND BOTTOMS (U.S. CLS. 22 AND 39).

LINDA LAVACHE, EXAMINING ATTORNEY

**CLASS 25—(Continued).**

SN 85-180,447. KNOW PLAY APPERAL, YORKTOWN, VA. FILED 11-18-2010.

## In Petersen We Trust

THE MARK CONSISTS OF STANDARD CHARACTERS WITHOUT CLAIM TO ANY PARTICULAR FONT, STYLE, SIZE, OR COLOR.

FOR A-SHIRTS; APPAREL FOR DANCERS, NAMELY, TEE SHIRTS, SWEATSHIRTS, PANTS, LEGGINGS, SHORTS AND JACKETS; ATHLETIC APPAREL, NAMELY, SHIRTS, PANTS, JACKETS, FOOTWEAR, HATS AND CAPS, ATHLETIC UNIFORMS; BABY BIBS NOT OF PAPER; BABY BODYSUITS; BABY BOTTOMS; BODY SHIRTS; BUTTON DOWN SHIRTS; BUTTON-FRONT ALOHA SHIRTS; CAMOUFLAGE SHIRTS; CAMP SHIRTS; CLOTHING FOR ATHLETIC USE, NAMELY, PADDED SHIRTS; CLOTHING FOR BABIES, TODDLERS AND CHILDREN, TREATED WITH FIRE AND HEAT RETARDANTS, NAMELY, PAJAMAS, JACKETS, SHIRTS, PANTS, JUMPERS; CLOTHING SHIELDS, NAMELY, PADS APPLIED TO THE UNDER-ARMS OF SHIRTS, BLOUSES AND SWEATERS; COLLARED SHIRTS; DRESS SHIRTS; FISHERMEN'S JACKETS; FISHING SHIRTS; GOLF PANTS, SHIRTS AND SKIRTS; GOLF SHIRTS; HOODED SWEAT SHIRTS; HUNTING JACKETS; HUNTING SHIRTS; JACKETS; KNIT JACKETS; KNIT SHIRTS; LEATHER SHIRTS; LONG JACKETS; LONG-SLEEVED SHIRTS; MEN'S AND WOMEN'S JACKETS, COATS, TROUSERS, VESTS; MOISTURE-WICKING SPORTS SHIRTS; NIGHT SHIRTS; OPEN-NECKED SHIRTS; OVER SHIRTS; PIQUE SHIRTS; POLO SHIRTS; RAIN JACKETS; RAINPROOF JACKETS; REVERSIBLE JACKETS; RUGBY SHIRTS; SCIENTIFIC AND TECHNOLOGICAL APPAREL, NAMELY, SHIRTS, PANTS, JACKETS, FOOTWEAR, HATS AND CAPS, UNIFORMS; SHELL JACKETS; SHIRT FRONTS; SHIRT YOKES; SHIRTS; SHIRTS AND SHORT-SLEEVED SHIRTS; SHIRTS AND SLIPS; SHIRTS FOR INFANTS, BABIES, TODDLERS AND CHILDREN; SHIRTS FOR SUITS; SHORT-SLEEVED OR LONG-SLEEVED T-SHIRTS; SHORT-SLEEVED SHIRTS; SLEEP SHIRTS; SLEEVED OR SLEEVELESS JACKETS; SLEEVES WORN SEPARATE AND APART FROM BLOUSES, SHIRTS AND OTHER TOPS; SPORT SHIRTS; SPORTS SHIRTS; SPORTS SHIRTS WITH SHORT SLEEVES; SWEAT BANDS; SWEAT JACKETS; SWEAT PANTS; SWEAT SHIRTS; SWEAT SHORTS; SWEAT SUITS; T-SHIRTS; TEE SHIRTS; TRACK JACKETS; TRAVEL CLOTHING CONTAINED IN A PACKAGE COMPRISING REVERSIBLE JACKETS, PANTS, SKIRTS, TOPS AND A BELT OR SCARF; TRIATHLON CLOTHING, NAMELY, TRIATHLON TIGHTS, TRIATHLON SHORTS, TRIATHLON SINGLETS, TRIATHLON SHIRTS, TRIATHLON SUITS; TROUSERS FOR SWEATING; TURTLE NECK SHIRTS; WATERPROOF JACKETS AND PANTS; WEARABLE GARMENTS AND CLOTHING, NAMELY, SHIRTS; WIND RESISTANT JACKETS; WIND SHIRTS; WIND-JACKETS; YOGA SHIRTS (U.S. CLS. 22 AND 39).

WILLIAM ROSSMAN, EXAMINING ATTORNEY

**CLASS 25—(Continued).**

SN 85-180,452. LAND OF THOUSAND HILLS COFFEE COMPANY, INC., ROSWELL, GA. FILED 11-18-2010.

Drink Coffee. Do Good.

THE MARK CONSISTS OF STANDARD CHARACTERS WITHOUT CLAIM TO ANY PARTICULAR FONT, STYLE, SIZE, OR COLOR.

FOR SHIRTS; SHIRTS AND SHORT-SLEEVED SHIRTS (U.S. CLS. 22 AND 39).

FIRST USE 3-1-2005; IN COMMERCE 3-1-2005.

TEJBIR SINGH, EXAMINING ATTORNEY

SN 85-180,458. MLA MULTIBRAND HOLDINGS, INC., VERNON, CA. FILED 11-18-2010.

TWELVE TWO

THE MARK CONSISTS OF STANDARD CHARACTERS WITHOUT CLAIM TO ANY PARTICULAR FONT, STYLE, SIZE, OR COLOR.

FOR CLOTHING, NAMELY, JACKETS, COATS, LEATHER COATS, RAIN COATS, DRESSES, EVENING GOWNS, DRESS SHIRTS, KNIT SHIRTS, SUITS, BLOUSES, T-SHIRTS, SKIRTS, SWEATERS, TURTLE-NECKS, VESTS, CARDIGANS, SUITS, PANTS, SLACKS, TROUSERS, JEANS, NIGHTGOWNS, SLEEP WEAR, STOCKINGS, PAJAMAS, NECKTIES, GLOVES, SCARVES, TANK TOPS, SHORTS, BELTS, UNDERWEAR, PANTIES, BODY SUITS, SLIPS, BRAS, LINGERIE, BATHING SUITS, FOOTWEAR, SHOES, BEACH SHOES, SANDALS, BOOTS, SLIPPERS, HEADBANDS, HATS, AND HEADWEAR (U.S. CLS. 22 AND 39).

LAURA KOVALSKY, EXAMINING ATTORNEY

SN 85-180,528. MLA MULTIBRAND HOLDINGS, INC., VERNON, CA. FILED 11-18-2010.

12-2

THE MARK CONSISTS OF STANDARD CHARACTERS WITHOUT CLAIM TO ANY PARTICULAR FONT, STYLE, SIZE, OR COLOR.

FOR CLOTHING, NAMELY, JACKETS, COATS, LEATHER COATS, RAIN COATS, DRESSES, EVENING GOWNS, DRESS SHIRTS, KNIT SHIRTS, SUITS, BLOUSES, T-SHIRTS, SKIRTS, SWEATERS, TURTLE-NECKS, VESTS, CARDIGANS, SUITS, PANTS, SLACKS, TROUSERS, JEANS, NIGHTGOWNS, SLEEPWEAR, STOCKINGS, PAJAMAS, NECKTIES, GLOVES, SCARVES, TANK TOPS, SHORTS, BELTS, UNDERWEAR, PANTIES, BODY SUITS, SLIPS, BRAS, LINGERIE, BATHING SUITS, FOOTWEAR, SHOES, BEACH SHOES, SANDALS, BOOTS, SLIPPERS, HEADBANDS, HATS AND HEADWEAR (U.S. CLS. 22 AND 39).

IRA J. GOODSAD, EXAMINING ATTORNEY

**CLASS 25—(Continued).**

SN 85-180,613. JOSH SUHRE DESIGN, LLC, CINCINNATI, OH. FILED 11-18-2010.



THE MARK CONSISTS OF A STYLIZED WORD "ENAI". FOR BELTS; CAPS; FOOTWEAR; GLOVES; HATS; JACKETS; PANTS; SHIRTS; SHOES; SOCKS; SWEAT SHIRTS (U.S. CLS. 22 AND 39).

TEJBIR SINGH, EXAMINING ATTORNEY

SN 85-180,618. JOSH SUHRE DESIGN, LLC, CINCINNATI, OH. FILED 11-18-2010.



THE MARK CONSISTS OF A STYLIZED LETTER "E". FOR BELTS; CAPS; FOOTWEAR; GLOVES; HATS; JACKETS; PANTS; SHIRTS; SHOES; SOCKS; SWEAT SHIRTS (U.S. CLS. 22 AND 39).

TEJBIR SINGH, EXAMINING ATTORNEY

SN 85-181,188. ELOISE CARR LLC, NEW YORK, NY. FILED 11-19-2010.

LoungeLux

THE MARK CONSISTS OF STANDARD CHARACTERS WITHOUT CLAIM TO ANY PARTICULAR FONT, STYLE, SIZE, OR COLOR.

FOR WOMENS APPAREL, NAMELY, LOUNGEWEAR, DRESSES, PANTS, JACKETS, SWEATERS, SKIRTS, SHORTS, TOPS, SLEEPWEAR, NIGHTWEAR, LINGERIE, SOCKS AND STOCKINGS; ATHLETIC APPAREL, NAMELY, SHIRTS, PANTS, JACKETS, FOOTWEAR, HATS AND CAPS, ATHLETIC UNIFORMS (U.S. CLS. 22 AND 39).

JULIE WATSON, EXAMINING ATTORNEY

**CLASS 25—(Continued).**

SN 85-181,455. HARVEY, JUANITA, DECATUR, IL. FILED 11-19-2010.

**NEFA (No Excuse For Abuse)**

THE MARK CONSISTS OF STANDARD CHARACTERS WITHOUT CLAIM TO ANY PARTICULAR FONT, STYLE, SIZE, OR COLOR.

FOR JACKETS; SHIRTS (U.S. CLS. 22 AND 39).  
REBECCA SMITH, EXAMINING ATTORNEY

SN 85-181,498. MARTIN III, JAMES, BRONX, NY. FILED 11-19-2010.

**Modern Gentry**

THE MARK CONSISTS OF STANDARD CHARACTERS WITHOUT CLAIM TO ANY PARTICULAR FONT, STYLE, SIZE, OR COLOR.

FOR BELTS; DRESSES; HATS; HOODED SWEAT SHIRTS; JACKETS; PANTS; SCARVES; SHIRTS; SHOES; SKIRTS; SOCKS; SWEATERS (U.S. CLS. 22 AND 39).  
JIM RINGLE, EXAMINING ATTORNEY

SN 85-181,538. PRANA LIVING, LLC, VISTA, CA. FILED 11-19-2010.



THE MARK CONSISTS OF A STYLIZED DRAWING OF A PERSON SITTING IN A YOGA POSE.

FOR FOOTWEAR ASSOCIATED WITH CLIMBING, HIKING, BIKING AND YOGA (U.S. CLS. 22 AND 39).  
LINDA MICKLEBURGH, EXAMINING ATTORNEY

**CLASS 25—(Continued).**

SN 85-182,680. DOING HIS WORK FIRST, INC., JACKSON, TN. FILED 11-22-2010.

**Doing His Work First**

THE MARK CONSISTS OF STANDARD CHARACTERS WITHOUT CLAIM TO ANY PARTICULAR FONT, STYLE, SIZE, OR COLOR.

FOR SHOES (U.S. CLS. 22 AND 39).  
JOHN GARTNER, EXAMINING ATTORNEY

SN 85-182,707. DOING HIS WORK FIRST, INC., JACKSON, TN. FILED 11-22-2010.

**Doing His Work First**

THE MARK CONSISTS OF STANDARD CHARACTERS WITHOUT CLAIM TO ANY PARTICULAR FONT, STYLE, SIZE, OR COLOR.

FOR BOOTS; CAPS WITH VISORS; COATS; HATS; HOODED SWEATSHIRTS; JOGGING PANTS; PANTS; SHIRTS; SHORTS; SWEATSHIRTS (U.S. CLS. 22 AND 39).  
JOHN GARTNER, EXAMINING ATTORNEY

SN 85-184,268. THE KAYO CORP, CARLSBAD, CA. FILED 11-24-2010.

**BLAZED**

THE MARK CONSISTS OF STANDARD CHARACTERS WITHOUT CLAIM TO ANY PARTICULAR FONT, STYLE, SIZE, OR COLOR.

FOR FOOTWEAR; HEADWEAR; HOODS; MEN'S AND WOMEN'S JACKETS, COATS, TROUSERS, VESTS; T-SHIRTS (U.S. CLS. 22 AND 39).

KELLEY WELLS, EXAMINING ATTORNEY

**CLASS 25—(Continued).**

SN 85-184,283. THE KAYO CORP, CARLSBAD, CA. FILED 11-24-2010.

**DA PLAYGROUND**

THE MARK CONSISTS OF STANDARD CHARACTERS WITHOUT CLAIM TO ANY PARTICULAR FONT, STYLE, SIZE, OR COLOR.

FOR HEADWEAR; HOODS; MEN'S AND WOMEN'S JACKETS, COATS, TROUSERS, VESTS; T-SHIRTS (U.S. CLS. 22 AND 39).

KELLEY WELLS, EXAMINING ATTORNEY

**CLASS 25—(Continued).**

SN 85-192,791. HAUS, PHIL, NEW YORK, NY. FILED 12-8-2010.



THE MARK CONSISTS OF A BIRDS EYE VIEW OF A HEAD WITH TWO ARMS REACHING OVER THE HEAD IN A YOGA SUN SALUTATION POSITION.

FOR CLOTHING, NAMELY, TOPS, BOTTOMS, T-SHIRTS, SHIRTS, PANTS, SHORTS, HOODED TOPS, UNDERGARMENTS, HOODS, JACKETS, SWEAT-ABSORBING UNDERGARMENTS, WRISTBANDS, KNITTED PANTS, KNITTED T-SHIRTS, SWEATSHIRTS (U.S. CLS. 22 AND 39).

DAWN HAN, EXAMINING ATTORNEY

SN 85-188,401. SISCO TEXTILES N.V., WILLEMSTAD, CUR-ACAO, NETHERLANDS ANTILLES, FILED 12-1-2010.

**SUPERKINI**

THE MARK CONSISTS OF STANDARD CHARACTERS WITHOUT CLAIM TO ANY PARTICULAR FONT, STYLE, SIZE, OR COLOR.

PRIORITY CLAIMED UNDER SEC. 44(D) ON ERPN CMNTY TM OFC APPLICATION NO. 009147703, FILED 6-2-2010.

FOR CLOTHING, NAMELY, SHIRTS, T-SHIRTS, PANTS, JACKETS, SKIRTS, SHORTS, BOARD SHORTS, SWIMWEAR, SWIMMING TRUNKS, SWIMSUITS, SWEATSHIRTS, SWEATERS, SOCKS, SCARVES; FOOTWEAR; SNOW BOOTS; SPORTS SHOES; LEISURE SHOES; BOOTIES FOR WATER SPORTS; ORIENTAL SLIPPERS; SLIPPERS; SANDALS; HEADGEAR, NAMELY, HOODS, CAPS, CAP PEAKS AND HATS; SPORTS AND LEISURE WEAR, NAMELY, WETSUITS, DRY SUITS, GLOVES, WETSUIT BOOTS, AND SKIWEAR, NAMELY, COATS, JACKETS, PANTS, GLOVES AND BOOTS; PROTECTIVE CLOTHING FOR SURFING, WINDSURFING AND WATER SKIING, AS WELL AS FOR OTHER WATER SPORTS, NAMELY, WETSUITS, DRY SUITS, WETSUIT BOOTS AND GLOVES; RASH GUARDS (U.S. CLS. 22 AND 39).

KHANH LE, EXAMINING ATTORNEY

SN 85-198,220. WIESNER PRODUCTS INC., NEW YORK, NY. FILED 12-15-2010.

**STREET KLUB**

THE MARK CONSISTS OF STANDARD CHARACTERS WITHOUT CLAIM TO ANY PARTICULAR FONT, STYLE, SIZE, OR COLOR.

FOR FOOTWEAR; UNDERWEAR (U.S. CLS. 22 AND 39).

TOBY BULLOFF, EXAMINING ATTORNEY

**CLASS 25—(Continued).**

SN 85-202,538. YOE ENTERPRISES OF NEVADA, INC., CHATTANOOGA, TN. FILED 12-21-2010.



NO CLAIM IS MADE TO THE EXCLUSIVE RIGHT TO USE "SOCKS", APART FROM THE MARK AS SHOWN. THE COLOR(S) RED IS/ARE CLAIMED AS A FEATURE OF THE MARK.

THE MARK CONSISTS OF THE WORD "JACK'S" IN SCRIPT, ABOVE THE WORD "SOCKS" IN CAPITAL LETTERS, SURROUNDED BY TWO LINES IN THE SHAPE OF A HEXAGON, ALL IN RED.

FOR SOCKS (U.S. CLS. 22 AND 39).

LINDA E. BLOHM, EXAMINING ATTORNEY

SN 85-202,563. ABBOTT, DEAN, ALBUQUERQUE, NM. FILED 12-21-2010.

**IT'S ABOUT TO GET UGLY**

THE MARK CONSISTS OF STANDARD CHARACTERS WITHOUT CLAIM TO ANY PARTICULAR FONT, STYLE, SIZE, OR COLOR.

FOR ATHLETIC APPAREL, NAMELY, SHIRTS, PANTS, JACKETS, FOOTWEAR, HATS AND CAPS, ATHLETIC UNIFORMS; ATHLETIC FOOTWEAR; ATHLETIC SHOES; ATHLETIC TIGHTS; ATHLETIC UNIFORMS; CLOTHING FOR ATHLETIC USE, NAMELY, PADDED ELBOW COMPRESSION SLEEVES BEING PART OF AN ATHLETIC GARMENT; CLOTHING FOR ATHLETIC USE, NAMELY, PADDED PANTS; CLOTHING FOR ATHLETIC USE, NAMELY, PADDED SHIRTS; CLOTHING FOR ATHLETIC USE, NAMELY, PADDED SHORTS; CLOTHING, NAMELY, ATHLETIC SLEEVES; FOOTWEAR FOR TRACK AND FIELD ATHLETICS; WOMEN'S ATHLETIC TOPS WITH BUILT-IN BRAS (U.S. CLS. 22 AND 39).

JUDITH HELFMAN, EXAMINING ATTORNEY

**CLASS 25—(Continued).**

SN 85-205,148. MAJOR LEAGUE SOCCER, LLC, NEW YORK, NY. FILED 12-23-2010.



THE MARK CONSISTS OF A STYLIZED REPRESENTATION OF A ROSE.

FOR T-SHIRTS; FLEECE TOPS; JERSEYS; HATS; CAPS; VISORS; BEANIES; SHORTS; SWEAT SUITS; JACKETS; HOODED SWEATSHIRTS; SCARVES (U.S. CLS. 22 AND 39).

ELISSA GARBER KON, EXAMINING ATTORNEY

SN 85-208,031. FAN SHOP LLC, SUSSEX, WI. FILED 12-30-2010.

**Narragansett Park**

THE MARK CONSISTS OF STANDARD CHARACTERS WITHOUT CLAIM TO ANY PARTICULAR FONT, STYLE, SIZE, OR COLOR.

FOR ATHLETIC APPAREL, NAMELY, SHIRTS, PANTS, JACKETS, FOOTWEAR, HATS AND CAPS, ATHLETIC UNIFORMS; BASEBALL CAPS; BASEBALL CAPS AND HATS; CAPS; CHILDREN'S AND INFANT'S APPAREL, NAMELY, JUMPERS, OVERALL SLEEPWEAR, PAJAMAS, RÖMPERS AND ONE-PIECE GARMENTS; COLLARED SHIRTS; DENIM JACKETS; DOWN JACKETS; GOLF CAPS; GOLF PANTS, SHIRTS AND SKIRTS; GOLF SHIRTS; GOLF SHORTS; GOLF TROUSERS; HATS; HATS FOR INFANTS, BABIES, TODDLERS AND CHILDREN; HEAVY JACKETS; HOODED SWEAT SHIRTS; JACKETS; LONG-SLEEVED SHIRTS; MEN'S AND WOMEN'S JACKETS, COATS, TROUSERS, VESTS; MOISTURE-WICKING SPORTS SHIRTS; OPEN-NECKED SHIRTS; OUTER JACKETS; OVER SHIRTS; PANTS; PIQUE SHIRTS; POLO SHIRTS; RAIN JACKETS; RAIN-PROOF JACKETS; REVERSIBLE JACKETS; RUGBY SHIRTS; SHIRTS AND SHORT-SLEEVED SHIRTS; SHIRTS FOR INFANTS, BABIES, TODDLERS AND CHILDREN; SHORT-SLEEVED OR LONG-SLEEVED T-SHIRTS; SHORTS; SKI JACKETS; SLEEPWEAR; SLEEVED OR SLEEVELESS JACKETS; SOCKS; SPORT SHIRTS; SPORTS JACKETS; SPORTS SHIRTS; SWEAT JACKETS; SWEAT SHIRTS; T-SHIRTS; TOBOGGAN HATS, PANTS AND CAPS; TRACK JACKETS; WATER-PROOF JACKETS AND PANTS; WIND RESISTANT JACKETS; WIND SHIRTS; WIND-JACKETS (U.S. CLS. 22 AND 39).

SUZANNE BLANE, EXAMINING ATTORNEY



**CLASS 25—(Continued).**

SN 85-209,604. FAN SHOP LLC, SUSSEX, WI. FILED 1-3-2011.

**CLASS 25—(Continued).**

SN 85-209,610. FAN SHOP LLC, SUSSEX, WI. FILED 1-3-2011.

## Roosevelt Raceway

## Garden State Park Racetrack

THE MARK CONSISTS OF STANDARD CHARACTERS WITHOUT CLAIM TO ANY PARTICULAR FONT, STYLE, SIZE, OR COLOR.

FOR ATHLETIC APPAREL, NAMELY, SHIRTS, PANTS, JACKETS, FOOTWEAR, HATS AND CAPS, ATHLETIC UNIFORMS; BASEBALL CAPS; BASEBALL CAPS AND HATS; CAPS; CHILDREN'S AND INFANT'S APPAREL, NAMELY, JUMPERS, OVERALL SLEEPWEAR, PAJAMAS, ROMPERS AND ONE-PIECE GARMENTS; COLLARED SHIRTS; DENIM JACKETS; DOWN JACKETS; GOLF CAPS; GOLF PANTS, SHIRTS AND SKIRTS; GOLF SHIRTS; GOLF SHORTS; GOLF TROUSERS; HATS; HATS FOR INFANTS, BABIES, TODDLERS AND CHILDREN; HEAVY JACKETS; HOODED SWEAT SHIRTS; JACKETS; LONG-SLEEVED SHIRTS; MEN'S AND WOMEN'S JACKETS, COATS, TROUSERS, VESTS; MOISTURE-WICKING SPORTS SHIRTS; OPEN-NECKED SHIRTS; OUTER JACKETS; OVER SHIRTS; PANTS; PIQUE SHIRTS; POLO SHIRTS; RAIN JACKETS; RAIN-PROOF JACKETS; REVERSIBLE JACKETS; RUGBY SHIRTS; SHIRTS AND SHORT-SLEEVED SHIRTS; SHIRTS FOR INFANTS, BABIES, TODDLERS AND CHILDREN; SHORT-SLEEVED OR LONG-SLEEVED T-SHIRTS; SHORTS; SKI JACKETS; SLEEPWEAR; SLEEVED OR SLEEVELESS JACKETS; SOCKS; SPORT SHIRTS; SPORTS JACKETS; SPORTS SHIRTS; SWEAT JACKETS; SWEAT SHIRTS; T-SHIRTS; TOBOGGAN HATS, PANTS AND CAPS; TRACK JACKETS; WATER-PROOF JACKETS AND PANTS; WIND RESISTANT JACKETS; WIND SHIRTS; WIND-JACKETS (U.S. CLS. 22 AND 39).

SUZANNE BLANE, EXAMINING ATTORNEY

THE MARK CONSISTS OF STANDARD CHARACTERS WITHOUT CLAIM TO ANY PARTICULAR FONT, STYLE, SIZE, OR COLOR.

FOR ATHLETIC APPAREL, NAMELY, SHIRTS, PANTS, JACKETS, FOOTWEAR, HATS AND CAPS, ATHLETIC UNIFORMS; BASEBALL CAPS; BASEBALL CAPS AND HATS; CAPS; CHILDREN'S AND INFANT'S APPAREL, NAMELY, JUMPERS, OVERALL SLEEPWEAR, PAJAMAS, ROMPERS AND ONE-PIECE GARMENTS; COLLARED SHIRTS; DENIM JACKETS; DOWN JACKETS; GOLF CAPS; GOLF PANTS, SHIRTS AND SKIRTS; GOLF SHIRTS; GOLF SHORTS; GOLF TROUSERS; HATS; HATS FOR INFANTS, BABIES, TODDLERS AND CHILDREN; HEAVY JACKETS; HOODED SWEAT SHIRTS; JACKETS; LONG-SLEEVED SHIRTS; MEN'S AND WOMEN'S JACKETS, COATS, TROUSERS, VESTS; MOISTURE-WICKING SPORTS SHIRTS; OPEN-NECKED SHIRTS; OUTER JACKETS; OVER SHIRTS; PANTS; PIQUE SHIRTS; POLO SHIRTS; RAIN JACKETS; RAIN-PROOF JACKETS; REVERSIBLE JACKETS; RUGBY SHIRTS; SHIRTS AND SHORT-SLEEVED SHIRTS; SHIRTS FOR INFANTS, BABIES, TODDLERS AND CHILDREN; SHORT-SLEEVED OR LONG-SLEEVED T-SHIRTS; SHORTS; SKI JACKETS; SLEEPWEAR; SLEEVED OR SLEEVELESS JACKETS; SOCKS; SPORT SHIRTS; SPORTS JACKETS; SPORTS SHIRTS; SWEAT JACKETS; SWEAT SHIRTS; T-SHIRTS; TOBOGGAN HATS, PANTS AND CAPS; TRACK JACKETS; WATER-PROOF JACKETS AND PANTS; WIND RESISTANT JACKETS; WIND SHIRTS; WIND-JACKETS (U.S. CLS. 22 AND 39).

SUZANNE BLANE, EXAMINING ATTORNEY

**CLASS 25—(Continued).**

SN 85-209,612. FAN SHOP LLC, SUSSEX, WI. FILED 1-3-2011.

**Havre De Grace Racetrack**

THE MARK CONSISTS OF STANDARD CHARACTERS WITHOUT CLAIM TO ANY PARTICULAR FONT, STYLE, SIZE, OR COLOR.

NO CLAIM IS MADE TO THE EXCLUSIVE RIGHT TO USE "HAVRE DE GRACE", APART FROM THE MARK AS SHOWN.

FOR ATHLETIC APPAREL, NAMELY, SHIRTS, PANTS, JACKETS, FOOTWEAR, HATS AND CAPS, ATHLETIC UNIFORMS; BASEBALL CAPS; BASEBALL CAPS AND HATS; CAPS; CHILDREN'S AND INFANT'S APPAREL, NAMELY, JUMPERS, OVERALL SLEEPWEAR, PAJAMAS, ROMPERS AND ONE-PIECE GARMENTS; COLLARED SHIRTS; DENIM JACKETS; DOWN JACKETS; GOLF CAPS; GOLF PANTS, SHIRTS AND SKIRTS; GOLF SHIRTS; GOLF SHORTS; GOLF TROUSERS; HATS; HATS FOR INFANTS, BABIES, TODDLERS AND CHILDREN; HEAVY JACKETS; HOODED SWEAT SHIRTS; JACKETS; LONG-SLEEVED SHIRTS; MEN'S AND WOMEN'S JACKETS, COATS, TROUSERS, VESTS; MOISTURE-WICKING SPORTS SHIRTS; OPEN-NECKED SHIRTS; OUTER JACKETS; OVER SHIRTS; PANTS; PIQUE SHIRTS; POLO SHIRTS; RAIN JACKETS; RAIN-PROOF JACKETS; REVERSIBLE JACKETS; RUGBY SHIRTS; SHIRTS AND SHORT-SLEEVED SHIRTS; SHIRTS FOR INFANTS, BABIES, TODDLERS AND CHILDREN; SHORT-SLEEVED OR LONG-SLEEVED T-SHIRTS; SHORTS; SKI JACKETS; SLEEPWEAR; SLEEVED OR SLEEVELESS JACKETS; SOCKS; SPORT SHIRTS; SPORTS JACKETS; SPORTS SHIRTS; SWEAT JACKETS; SWEAT SHIRTS; T-SHIRTS; TOBOGGAN HATS, PANTS AND CAPS; TRACK JACKETS; WATER-PROOF JACKETS AND PANTS; WIND RESISTANT JACKETS; WIND SHIRTS; WIND-JACKETS (U.S. CLS. 22 AND 39).

SUZANNE BLANE, EXAMINING ATTORNEY

SN 85-211,218. LIVE NATION WORLDWIDE, INC., BEVERLY HILLS, CA. FILED 1-5-2011.

**ARTIST NATION**

THE MARK CONSISTS OF STANDARD CHARACTERS WITHOUT CLAIM TO ANY PARTICULAR FONT, STYLE, SIZE, OR COLOR.

FOR CLOTHING, NAMELY, SHIRTS, SWEATSHIRTS, PANTS, JACKETS, HATS AND CAPS (U.S. CLS. 22 AND 39).

RAUL CORDOVA, EXAMINING ATTORNEY

**CLASS 25—(Continued).**

SN 85-211,771. BBBT, LLC, NEW EGYPT, NJ. FILED 1-6-2011.



THE MARK CONSISTS OF THE STYLIZED LETTERS "D" AND "N".

FOR WEARABLE GARMENTS AND CLOTHING, NAMELY, SHIRTS (U.S. CLS. 22 AND 39).

JACLYN KIDWELL WALKER, EXAMINING ATTORNEY

SN 85-216,574. SR HOLDINGS, LLC, LEXINGTON, MA. FILED 1-13-2011.

**NO SOCKS ALLOWED**

THE MARK CONSISTS OF STANDARD CHARACTERS WITHOUT CLAIM TO ANY PARTICULAR FONT, STYLE, SIZE, OR COLOR.

FOR FOOTWEAR (U.S. CLS. 22 AND 39).

JOHN DWYER, EXAMINING ATTORNEY

SN 85-216,588. SR HOLDINGS, LLC, LEXINGTON, MA. FILED 1-13-2011.

**OWN THE ORIGINAL**

THE MARK CONSISTS OF STANDARD CHARACTERS WITHOUT CLAIM TO ANY PARTICULAR FONT, STYLE, SIZE, OR COLOR.

FOR FOOTWEAR; HATS; T-SHIRTS (U.S. CLS. 22 AND 39).

JOHN DWYER, EXAMINING ATTORNEY

**CLASS 25—(Continued).**

SN 85-216,602. SR HOLDINGS, LLC, LEXINGTON, MA.  
FILED 1-13-2011.

**SEE WITH YOUR FEET**

THE MARK CONSISTS OF STANDARD CHARACTERS  
WITHOUT CLAIM TO ANY PARTICULAR FONT, STYLE,  
SIZE, OR COLOR.  
FOR FOOTWEAR (U.S. CLS. 22 AND 39).  
JOHN DWYER, EXAMINING ATTORNEY

SN 85-219,292. SOLEMATES, LLC, OLD GREENWICH, CT.  
FILED 1-17-2011.

**Celebrating Life with  
Every Step**

THE MARK CONSISTS OF STANDARD CHARACTERS  
WITHOUT CLAIM TO ANY PARTICULAR FONT, STYLE,  
SIZE, OR COLOR.  
FOR FOOTWEAR, NAMELY, PUMPS; INSOLES FOR  
FOOTWEAR; TIPS FOR FOOTWEAR; UNDERGAR-  
MENT ACCESSORIES, NAMELY, REMOVABLE SILI-  
CONE BUTTOCK ENHANCER PADS; WATERPROOF  
FOOTWEAR (U.S. CLS. 22 AND 39).  
JOHN GARTNER, EXAMINING ATTORNEY

SN 85-220,314. WINDSOR SMITH PTY LTD., PRESTON,  
VICTORIA 3072, AUSTRALIA, FILED 1-18-2011.

**WINDSORSMITH**

THE MARK CONSISTS OF STYLIZED WORDS "WIND-  
SOR SMITH" WITH THE LETTER "X".  
FOR FOOTWEAR (U.S. CLS. 22 AND 39).  
LOURDES AYALA, EXAMINING ATTORNEY

**CLASS 25—(Continued).**

SN 85-221,871. PRL USA HOLDINGS, INC., WILMINGTON,  
DE. FILED 1-20-2011.

**BLACK WATCH**

THE MARK CONSISTS OF STANDARD CHARACTERS  
WITHOUT CLAIM TO ANY PARTICULAR FONT, STYLE,  
SIZE, OR COLOR.  
FOR BEACHWEAR; CAPS; COATS; DRESSES; HATS;  
JACKETS; PANTS; RAINCOATS; SHIRTS; T-SHIRTS;  
UNDERWEAR (U.S. CLS. 22 AND 39).  
FIRST USE 7-0-2007; IN COMMERCE 7-0-2007.  
DAVID H. STINE, EXAMINING ATTORNEY

SN 85-228,321. LUCKY BRAND DUNGAREES, INC., VER-  
NON, CA. FILED 1-27-2011.

**LUCKY BRAND**

THE MARK CONSISTS OF STANDARD CHARACTERS  
WITHOUT CLAIM TO ANY PARTICULAR FONT, STYLE,  
SIZE, OR COLOR.  
OWNER OF U.S. REG. NOS. 1,646,123, 3,107,591 AND  
OTHERS.  
NO CLAIM IS MADE TO THE EXCLUSIVE RIGHT TO  
USE "BRAND", APART FROM THE MARK AS SHOWN.  
FOR BELTS; BLOUSES; BOTTOMS; BOXER SHORTS;  
DRESSES; HATS; JACKETS; JEANS; PANTS; SHIRTS;  
SHOES; SHORTS; SKIRTS; SWEAT PANTS; SWEATERS;  
SWEATSHIRTS; SWIMWEAR; T-SHIRTS; TANK TOPS;  
TOPS; VESTS (U.S. CLS. 22 AND 39).  
FIRST USE 12-7-1990; IN COMMERCE 12-7-1990.  
CURTIS FRENCH, EXAMINING ATTORNEY

**CLASS 26—FANCY GOODS**

SN 85-060,465. INTERNATIONAL PLAYTHINGS LLC, PAR-  
SIPPANY, NJ. FILED 6-11-2010.

**WONDERBEADS**

THE MARK CONSISTS OF STANDARD CHARACTERS  
WITHOUT CLAIM TO ANY PARTICULAR FONT, STYLE,  
SIZE, OR COLOR.  
FOR CHILDREN'S ARTS AND CRAFT KITS COM-  
PRISED OF BEADS AND TEMPLATES FOR HANDI-  
CRAFT WORK (U.S. CLS. 37, 39, 40, 42 AND 50).  
JASON TURNER, EXAMINING ATTORNEY

**CLASS 26—(Continued).**

SN 85-160,761. GLORIA INTERNATIONAL INC., VERDUN, CANADA, FILED 10-25-2010.

**BOUTON MAGIQUE**

THE MARK CONSISTS OF STANDARD CHARACTERS WITHOUT CLAIM TO ANY PARTICULAR FONT, STYLE, SIZE, OR COLOR.

NO CLAIM IS MADE TO THE EXCLUSIVE RIGHT TO USE "BOUTON", APART FROM THE MARK AS SHOWN.

FOR CLOTHING ACCESSORY, NAMELY, A BUTTON REPLACEMENT WHICH ALLOWS ITS USER TO INCREASE THE SIZE OF ITS CLOTHES, MORE PARTICULARLY THE SIZE OF ITS SHIRT, BLOUSE OR POLO SHIRT COLLAR, THE SIZE OF ITS SHIRT OR BLOUSE CUFFS OR THE WAIST SIZE OF ITS PANTS OR SKIRT (U.S. CLS. 37, 39, 40, 42 AND 50).

FIRST USE 7-1-2010; IN COMMERCE 7-1-2010.

DORITT L. CARROLL, EXAMINING ATTORNEY

SN 85-176,700. SOLEMATES, LLC, OLD GREENWICH, CT, FILED 11-15-2010.

**Put on your party shoes.**

THE MARK CONSISTS OF STANDARD CHARACTERS WITHOUT CLAIM TO ANY PARTICULAR FONT, STYLE, SIZE, OR COLOR.

FOR CLOTHING ACCESSORIES, NAMELY, PLASTIC CLIPS THAT ATTACH TO THE LOWER HEM OF SHIRTS AND BLOUSES THAT ALLOWS THE USER TO TIGHTEN THE HEM (U.S. CLS. 37, 39, 40, 42 AND 50).

JOHN GARTNER, EXAMINING ATTORNEY

SN 85-177,031. DIRTY SNOWFLAKE APPAREL, LLC, BEND, OR, FILED 11-15-2010.

**FEATHER-ETTE**

THE MARK CONSISTS OF STANDARD CHARACTERS WITHOUT CLAIM TO ANY PARTICULAR FONT, STYLE, SIZE, OR COLOR.

FOR HAIR CLIPS (U.S. CLS. 37, 39, 40, 42 AND 50).

FIRST USE 10-18-2010; IN COMMERCE 10-18-2010.

ALYSSA STEEL, EXAMINING ATTORNEY

**CLASS 26—(Continued).**

SN 85-178,295. SR HOLDINGS, LLC, LEXINGTON, MA, FILED 11-16-2010.

**A PASSION FOR THE SEA**

THE MARK CONSISTS OF STANDARD CHARACTERS WITHOUT CLAIM TO ANY PARTICULAR FONT, STYLE, SIZE, OR COLOR.

FOR SHOE LACES, NEEDLES FOR USE IN LACING SHOES (U.S. CLS. 37, 39, 40, 42 AND 50).

FIRST USE 2-0-2009; IN COMMERCE 2-0-2009.

JOHN DWYER, EXAMINING ATTORNEY

SN 85-211,226. LIVE NATION WORLDWIDE, INC., BEVERLY HILLS, CA, FILED 1-5-2011.

**ARTIST NATION**

THE MARK CONSISTS OF STANDARD CHARACTERS WITHOUT CLAIM TO ANY PARTICULAR FONT, STYLE, SIZE, OR COLOR.

FOR ORNAMENTAL NOVELTY BUTTONS AND PINS (U.S. CLS. 37, 39, 40, 42 AND 50).

RAUL CORDOVA, EXAMINING ATTORNEY

**CLASS 27—FLOOR COVERINGS**

SN 85-117,731. HOME DYNAMIX LLC., MOONACHIE, NJ, FILED 8-27-2010.

**Feel-At-Ease**

THE MARK CONSISTS OF STANDARD CHARACTERS WITHOUT CLAIM TO ANY PARTICULAR FONT, STYLE, SIZE, OR COLOR.

FOR ANTI-FATIGUE FLOOR MAT (U.S. CLS. 19, 20, 37, 42 AND 50).

FIRST USE 5-20-2010; IN COMMERCE 6-15-2010.

JOSETTE BEVERLY, EXAMINING ATTORNEY

**CLASS 27—(Continued).**

SN 85-119,634. HOME DYNAMIX LLC., MOONACHIE, NJ. FILED 8-31-2010.

# COMFORT PRO MAT

THE MARK CONSISTS OF STANDARD CHARACTERS WITHOUT CLAIM TO ANY PARTICULAR FONT, STYLE, SIZE, OR COLOR.

NO CLAIM IS MADE TO THE EXCLUSIVE RIGHT TO USE "MAT", APART FROM THE MARK AS SHOWN. FOR ANTI-FATIGUE FLOOR MAT (U.S. CLS. 19, 20, 37, 42 AND 50).  
JOSETTE BEVERLY, EXAMINING ATTORNEY



SN 85-155,202. LOT 26 STUDIO, INC., SAN FRANCISCO, CA. FILED 10-18-2010.

## ADHESIVE REFLECTIONS

THE MARK CONSISTS OF STANDARD CHARACTERS WITHOUT CLAIM TO ANY PARTICULAR FONT, STYLE, SIZE, OR COLOR.

NO CLAIM IS MADE TO THE EXCLUSIVE RIGHT TO USE "ADHESIVE", APART FROM THE MARK AS SHOWN. FOR NON-TEXTILE WALL COVERINGS (U.S. CLS. 19, 20, 37, 42 AND 50).  
FIRST USE 8-1-2010; IN COMMERCE 8-1-2010.  
JEFFREY LOOK, EXAMINING ATTORNEY



SN 85-176,772. MILLIKEN & COMPANY, SPARTANBURG, SC. FILED 11-15-2010.

## PURPOSEFUL PLAY

THE MARK CONSISTS OF STANDARD CHARACTERS WITHOUT CLAIM TO ANY PARTICULAR FONT, STYLE, SIZE, OR COLOR.

FOR CARPET BACKING; CARPET TILES; CARPETS AND RUGS; FLOOR COVERINGS; FLOOR MATS; HARD SURFACE COVERINGS FOR FLOORS (U.S. CLS. 19, 20, 37, 42 AND 50).  
KATHERINE STOIDES, EXAMINING ATTORNEY

**CLASS 27—(Continued).**

SN 85-176,897. MILLIKEN & COMPANY, SPARTANBURG, SC. FILED 11-15-2010.

## PLAY WITH PURPOSE

THE MARK CONSISTS OF STANDARD CHARACTERS WITHOUT CLAIM TO ANY PARTICULAR FONT, STYLE, SIZE, OR COLOR.

FOR CARPET BACKING; CARPET TILES; CARPETS AND RUGS; FLOOR COVERINGS; FLOOR MATS; HARD SURFACE COVERINGS FOR FLOORS (U.S. CLS. 19, 20, 37, 42 AND 50).  
KATHERINE STOIDES, EXAMINING ATTORNEY



**CLASS 28—TOYS AND SPORTING GOODS**

SN 75-424,804. SOFTSPIKES, LLC, GAITHERSBURG, MD. FILED 1-28-1998.

## SOFTSPIKES

OWNER OF U.S. REG. NO. 1,773,925 AND OTHERS. SEC. 2(F).  
FOR GOLF BALL MARK REPAIR TOOLS (U.S. CLS. 22, 23, 38 AND 50).  
FIRST USE 3-0-1995; IN COMMERCE 3-0-1995.  
KIMBERLY KREHELY, EXAMINING ATTORNEY



SN 76-701,452. BESTGRIPS.COM, INC., CONROE, TX. FILED 2-2-2010.

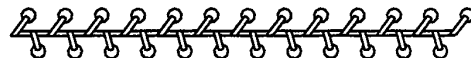

THE MARK CONSISTS OF A STITCH PATTERN. FOR GOLF CLUB GRIPS (U.S. CLS. 22, 23, 38 AND 50).  
JOHN HWANG, EXAMINING ATTORNEY

**CLASS 28—(Continued).**

SN 77-497,513. JOHNSON, BRIAN T., DBA QUANTUM SPORTS INDUSTRIES, MANCHAUG, MA. FILED 6-12-2008.

**SABRE TOOTH**

THE MARK CONSISTS OF STANDARD CHARACTERS WITHOUT CLAIM TO ANY PARTICULAR FONT, STYLE, SIZE, OR COLOR.

FOR GOLF CLUB BAGS; GOLF CLUBS (U.S. CLS. 22, 23, 38 AND 50).

FIRST USE 2-6-2003; IN COMMERCE 6-7-2003.  
COLLEEN KEARNEY, EXAMINING ATTORNEY

SN 77-569,122. FUJI MEDIA HOLDINGS, INC., MINATO-KU, TOKYO, JAPAN, FILED 9-12-2008.

**フジ・メディア・ホールディングス**  
**Fuji Media Holdings**

PRIORITY CLAIMED UNDER SEC. 44(D) ON JAPAN APPLICATION NO. 2008-026431, FILED 4-4-2008.

OWNER OF JAPAN REG. NO. 5186155, DATED 12-5-2008, EXPIRES 12-5-2018.

NO CLAIM IS MADE TO THE EXCLUSIVE RIGHT TO USE "MEDIA HOLDINGS" AND THE NON-LATIN CHARACTERS THAT TRANSLITERATE TO "MEDEIA HORUDEINGSUSU", APART FROM THE MARK AS SHOWN.

THE MARK CONSISTS OF JAPANESE CHARACTERS AND THE PHRASE "FUJI MEDIA HOLDINGS".

THE NON-LATIN CHARACTERS IN THE MARK TRANSLITERATE TO "FUJI MEDEIA HORUDEINGSUSU" AND THIS MEANS "FUJI MEDIA HOLDINGS" IN ENGLISH.

FOR METAL TOYS, NAMELY, TOY CLOCKS AND WATCHES; ROLLER TOYS, NAMELY, ROLLER SKATE AND SKATEBOARDS; CLOCKWORK TOYS; TOY BROOCHES; TOY WHISTLES; LEVER ACTION TOYS; WOODEN OR BAMBOO TOYS, NAMELY, TOY BUILDING BLOCKS AND STILTS FOR RECREATIONAL PURPOSES; WOODEN TOYS SHAPED BY JIGSAWS, NAMELY, PUZZLES; HOLLOW TOY-MODELS OF PLYWOOD OR VENEER, NAMELY, PUPPETS; WOODEN TOYS SHAPED BY TURNING LATHES, NAMELY, PUPPETS; PAPER TOYS, NAMELY, KARUTA PLAYING CARDS; SETS OF SHEET-PAPER DOLLS AND CLOTHES THEREFOR; PLUSH TOYS; PLASTIC TOYS, NAMELY, ONE-PIECE CELLULOID TOYS AND HOLLOW CELLULOID TOYS IN THE FORM OF PLASTIC CHARACTER TOYS AND MODELED PLASTIC TOY FIGURINES; RUBBER TOYS, NAMELY, HOLLOW RUBBER TOYS IN THE FORM OF RUBBER CHARACTER TOYS, FORMED BY MOLDING PROCESS; RUBBER BALLS; INFLATABLE THIN RUBBER TOYS; HOLLOW RUBBER TOYS IN THE FORM OF RUBBER CHARACTER TOYS AND INFLATABLE THIN RUBBER TOYS, FORMED BY BONDING; SOLID RUBBER TOYS IN THE FORM OF RUBBER CHARACTER TOYS FORMED BY MOLDING PROCESS; MUSICAL TOYS; TOY SETS, NAMELY, TOY CONSTRUCTION SETS, TOY SETS OF CARPENTERS' TOOLS, AND HOUSEKEEPING-PLAY SETS COMPRISING TOY TABLEWARE, BAKEWARE, AND COOKWARE; ELECTRIC TOY MODEL TRAIN SETS; DOLLS; GO GAMES; JAPANESE PLAYING CARD KNOWN AS UTAGARUTA; JAPANESE PLAYING CARD KNOWN AS HANAFUDA; JAPANESE CHESS KNOWN AS SHOGI GAMES; DICE AND DICE CUPS; JAPANESE DICE GAMES KNOWN AS SUGOROKU; CHESS SETS;

**CLASS 28—(Continued).**

CHECKERS AND CHECKER SETS; DOMINOES; PLAYING CARDS; MAH-JONG GAMES; SPORTING EQUIPMENT, NAMELY, BASEBALL GLOVES, SOFTBALLS, BATTING GLOVES, BACKSTOPS, BASEBALL BATS, BASEBALL BAT CASES, BASEBALL BASES, CATCHERS' MASKS, BASEBALL MITTS, BASEBALL CHEST PROTECTORS, SHOULDER PADS FOR ATHLETIC USE, SHIN PADS AND GUARDS FOR ATHLETIC USE, TUBES FOR BALL GAMES, NAMELY, BASKETBALL TUBE BAGS AND VOLLEYBALL TUBE BAGS; NETS FOR BALL GAMES, KNEE PADS AND GUARDS FOR SPORTS, DISCUSSES FOR FIELD SPORTS, AERODYNAMIC DISK FOR USE IN PLAYING CATCHING GAMES, NAMELY, THROWING CIRCLES; STARTING BLOCKS FOR TRACK SPORTS, ALUMINUM CROSSBARS FOR FOOTBALL AND SOCCER, HURDLES FOR TRACK SPORTS, RELAY BATONS, HAMMERS FOR TRACK AND FIELD SPORTS, TARGETS FOR FIELD SPORTS, VAULTING POLES, JAVELINS FOR FIELD SPORTS, BADMINTON SHUTTLECOCKS, TENNIS BALLS, NETS FOR TENNIS OR BADMINTON, RACKETS FOR TENNIS OR BADMINTON, STRINGS FOR TENNIS AND BADMINTON RACKETS, RACKET CASES FOR TENNIS OR BADMINTON, TABLE TENNIS TABLES, NETS FOR TABLE TENNIS, TABLE TENNIS BALLS, TABLE TENNIS PADDLES, TABLE TENNIS PADDLE CASES, HOCKEY STICKS, SHIN PADS FOR HOCKEY, HOCKEY GLOVES, HOCKEY PUCKS, FIELD HOCKEY BALLS, CHEST PROTECTORS, GOLF BAGS, GOLF CLUBS, GOLF BALL MARKERS, GOLF TEES, GOLF BALLS, PUTTING PRACTICE MATS, BOWLING GLOVES, BOWLING BAGS, BOWLING BALLS, SEAL SKINS FOR COVERING SKIS, SKIS, SKI EDGES, SKI CASES, SKI BINDINGS, SCRAPERS FOR SKIS, SKI POLES, ICE SKATE BLADES, ICE SKATES, ROLLER SKATES, BOXING GLOVES, BOXING BAGS, NAMELY, SAND BAGS FOR BOXING PRACTICE, PUNCHING BALLS FOR BOXING PRACTICE, ATHLETIC TAPE, NAMELY, FIST BANDAGES FOR BOXING, MOUTHPIECES FOR BOXING, ARCHERY EQUIPMENT, NAMELY, BOWSTRINGS, TARGETS, ARROWS, QUIVERS, BOWS AND BOWS FOR JAPANESE ARCHERY KNOWN AS YUMI BOWS, FENCING EQUIPMENT, NAMELY, SABRES, ÉPÉE, GAUNTLETS, FOILS, FENCING MASKS, KOTE GAUNTLETS, KENDO BAMBOO SWORDS, KENDO PLASTRONS, KENDO WOODEN SWORDS, KENDO MASKS, GYMNAS TIC APPARATUS, NAMELY, POMMEL HORSES, SPRINGBOARDS, RINGS, HORIZONTAL BARS, GYMNAS TIC BOXES, BALANCE BEAMS, PARALLEL BARS, RIBBONS, CLUBS, BALLS AND HOOPS SPECIALLY ADAPTED FOR RHYTHMIC GYMNAS TIC; WEIGHT LIFTING EQUIPMENT, NAMELY, DUMB-BELLS, WEIGHT LIFTING BELTS, DUMB-BELL SHAFTS, BAR-BELLS; SWIM FINS; SCUBA EQUIPMENT, NAMELY, SPRING-ACTIVATED SPEAR GUNS; SAILBOARDS FOR BOARDSAILING, CHEST EXPANDERS, CURLING IMPLEMENTS, NAMELY, CURLING STONES, CURLING CRUTCHES, CURLING BRUSHES, AND CURLING STICKS; INFLATABLE PREFABRICATED SWIMMING POOLS, SURF BOARDS, BAGS ESPECIALLY DESIGNED FOR SURFBOARDS, ATHLETIC WRIST AND JOINT SUPPORTS, SEE-SAWS, WATERSKIS, SKATEBOARDS, SNOW BOARDS, PLAYGROUND EQUIPMENT, NAMELY, SLIDE AND SWINGS, SKIPPING ROPES, TWIRLING BATONS, PARAGLIDERS, HANG GLIDERS, BOBSLEDS, ROCKING HORSES; AND MAGIC TRICKS COMPRISING CLOTH, RUBBER FLOWERS, COINS, BALLS, HATS, CARDS, AND STICKS FOR CONJURING (U.S. CLS. 22, 23, 38 AND 50).

BENJAMIN OKEKE, EXAMINING ATTORNEY

**CLASS 28—(Continued).**

SN 77-640,053. SUMMIT ENTERTAINMENT, LLC, SANTA MONICA, CA. FILED 12-25-2008.

**TWILIGHT**

THE MARK CONSISTS OF STANDARD CHARACTERS WITHOUT CLAIM TO ANY PARTICULAR FONT, STYLE, SIZE, OR COLOR.

FOR ACTION FIGURES, PUZZLES, BOARD GAMES, DOLLS, ACTION SKILL GAMES, AMUSEMENT GAME MACHINES, ARCADE GAMES, BALLOONS, BALLS FOR GAMES, SPORTS BALLS, BENDABLE TOYS, CARD GAMES, BODY BOARDS, CARNIVAL MASKS, PET TOYS, CHESS GAMES, CHECKER SETS, CHRISTMAS STOCKINGS, CHRISTMAS TREE ORNAMENTS, CHRISTMAS TREE SKIRTS, COVERS FOR GOLF CLUBS, DOLL CASES, DOLL CLOTHING, FLYING DISCS, GOLF BALLS, GOLF BALL MARKERS, KITES, PLAYING CARDS, PARTY FAVORS IN THE NATURE OF SMALL TOYS, PLUSH TOYS, YO-YOS, AND DECORATIVE WIND SOCKS (U.S. CLS. 22, 23, 38 AND 50).  
CYNTHIA TRIPI, EXAMINING ATTORNEY

SN 77-773,421. CALLAWAY GOLF COMPANY, CARLSBAD, CA. FILED 7-2-2009.

**Diablo Edge Hybrid**

THE MARK CONSISTS OF STANDARD CHARACTERS WITHOUT CLAIM TO ANY PARTICULAR FONT, STYLE, SIZE, OR COLOR.

OWNER OF U.S. REG. NO. 3,595,821.  
NO CLAIM IS MADE TO THE EXCLUSIVE RIGHT TO USE "HYBRID", APART FROM THE MARK AS SHOWN.  
THE ENGLISH TRANSLATION OF "DIABLO" IN THE MARK IS "DEVIL".  
FOR GOLF BAGS (U.S. CLS. 22, 23, 38 AND 50).  
LINDSEY RUBIN, EXAMINING ATTORNEY

**CLASS 28—(Continued).**

SN 77-846,838. SERIOUS ANTICS, INC., FAYETTEVILLE, AR. FILED 10-12-2009.

**MASCOT SLINGY**

THE MARK CONSISTS OF STANDARD CHARACTERS WITHOUT CLAIM TO ANY PARTICULAR FONT, STYLE, SIZE, OR COLOR.

NO CLAIM IS MADE TO THE EXCLUSIVE RIGHT TO USE "MASCOT", APART FROM THE MARK AS SHOWN.  
FOR TOYS, NAMELY, BENDABLE PLAY FIGURES; TOY ACTION FIGURES AND ACCESSORIES THEREFOR; SLING SHOTS; AUDIO AND VISUAL TOYS, NAMELY, TALKING DOLLS, MECHANICAL ACTION TOYS; BATTERY-OPERATED ACTION TOYS; DOLLS, PUPPETS; STUFFED AND PLUSH TOYS; LATEX SQUEEZE TOY FIGURES (U.S. CLS. 22, 23, 38 AND 50).  
INGRID C. EULIN, EXAMINING ATTORNEY

SN 77-924,363. DAVID ESTES, ALEXANDRIA, VA. FILED 1-31-2010.

**KINGS ONLY**

THE MARK CONSISTS OF STANDARD CHARACTERS WITHOUT CLAIM TO ANY PARTICULAR FONT, STYLE, SIZE, OR COLOR.

NO CLAIM IS MADE TO THE EXCLUSIVE RIGHT TO USE "KINGS", APART FROM THE MARK AS SHOWN.  
FOR INTERACTIVE BOARD GAMES, NAMELY, SPECIALIZED CHESS GAMES (U.S. CLS. 22, 23, 38 AND 50).  
FIRST USE 3-1-2009; IN COMMERCE 3-1-2009.  
SIMON TENG, EXAMINING ATTORNEY

SN 79-081,612. GUANGDONG JUMBO GRAND PLASTIC; MOULDING INDUSTRIAL CO., LTD., CHINA, FILED 3-31-2010.

OWNER OF INTERNATIONAL REGISTRATION 1036080 DATED 3-31-2010, EXPIRES 3-31-2020.

THE MARK CONSISTS OF THE TWO CHINESE CHARACTERS WHOSE TRANSLITERATION IS "BANG BAO".  
THE ENGLISH TRANSLATION OF THE FOREIGN

**CLASS 28—(Continued).**

WORD(S) IN THE MARK IS: THE FIRST CHINESE CHARACTER WHOSE TRANSLITERATION IS "BANG" MEANS "NATION"; THE SECOND CHINESE CHARACTER WHOSE TRANSLITERATION IS "BAO" MEANS "TREASURE"; THE COMBINATION OF THE TWO CHINESE CHARACTERS HAS NO SIGNIFICANCE IN THE RELEVANT TRADE OR INDUSTRY, AND HAS NO GEOGRAPHICAL SIGNIFICANCE, AND HAS NO MEANING IN A FOREIGN LANGUAGE, AND HAS NO SIGNIFICANCE AS APPLIED TO THE GOODS.

THE TRANSLITERATION OF THE NON-LATIN CHARACTERS IN THE MARK IS "BANG BAO".

FOR TOY VEHICLES; BODY-TRAINING APPARATUS; MACHINES FOR PHYSICAL EXERCISES; CHESS GAMES; BALLS FOR GAMES (U.S. CLS. 22, 23, 38 AND 50).

ALEXANDER L. POWERS, EXAMINING ATTORNEY

SN 79-082,273. GUANGDONG JUMBO GRAND PLASTIC; MOULDING INDUSTRIAL CO., LTD., CHINA, FILED 4-1-2010.

# BanBao

OWNER OF INTERNATIONAL REGISTRATION 1037827 DATED 4-1-2010, EXPIRES 4-1-2020.

THE MARKS CONSISTS OF THE ENGLISH WORDING "BANBAO".

THE ENGLISH TRANSLATION OF THE FOREIGN WORD(S) IN THE MARK IS: THE ENGLISH WORDING "BANBAO" HAS NO SIGNIFICANCE IN THE RELEVANT TRADE OR INDUSTRY, AND HAS NO GEOGRAPHICAL SIGNIFICANCE, AND HAS NO MEANING IN A FOREIGN LANGUAGE, AND HAS NO SIGNIFICANCE AS APPLIED TO THE GOODS.

FOR TOY VEHICLES; BODY-TRAINING APPARATUS; MACHINES FOR PHYSICAL EXERCISES; CHESS GAMES; BALLS FOR GAMES (U.S. CLS. 22, 23, 38 AND 50).

ALEXANDER L. POWERS, EXAMINING ATTORNEY

SN 79-082,468. SOVMESTNOE OBSHESTVO S OGRANICHENNOJ; OTVETSTVENNOSTYU "PP POLESIE", BELARUS, FILED 3-31-2010.



PRIORITY DATE OF 10-2-2009 IS CLAIMED.

OWNER OF INTERNATIONAL REGISTRATION 1038408 DATED 3-31-2010, EXPIRES 3-31-2020.

THE COLOR(S) YELLOW, ORANGE, RED, WHITE AND BLACK IS/ARE CLAIMED AS A FEATURE OF THE MARK.

THE MARK CONSISTS OF THE DEPICTION OF A SUN CONTAINING A FACE AND THE STYLIZED WORD "LOLY". THE COLOR YELLOW APPEARS IN THE DEPICTION OF THE SUN. THE COLOR ORANGE APPEARS IN THE STYLIZED WORD "LOLY" AS WELL AS THE DEPIC-

**CLASS 28—(Continued).**

TION OF THE SUN. THE COLOR RED APPEARS IN THE OUTLINE BORDER OF THE STYLIZED WORD "LOLY" AS WELL AS THE BORDER OF THE SUN AND THE DEPICTION OF THE MOUTH AND EYES OF THE FACE LOCATED IN THE SUN. THE COLOR BLACK APPEARS IN THE DEPICTION OF THE PUPILS IN THE EYES OF THE FACE LOCATED IN THE SUN. THE COLOR WHITE APPEARS IN THE DEPICTION OF THE EYES OF THE FACE LOCATED IN THE SUN AS WELL AS THE STYLIZED LETTER "O" IN THE WORD "LOLY".

FOR TOY CONSTRUCTION SETS; NON-ELECTRONIC TOY VEHICLES; TOY BUILDING BLOCKS CAPABLE OF INTERCONNECTION; TOY CONSTRUCTION BLOCKS; TOY BOATS; PLAY SETS FOR ACTION FIGURES; PLAY HOUSES AND TOY ACCESSORIES THEREFOR, ROLE PLAYING TOYS IN THE NATURE OF PLAY SETS FOR CHILDREN CONSISTING OF TOY TABLEWARE COMPRISING CUPS, SPOONS, FORKS, KNIVES, DISHES, POTS AND PANS, CHEESE GRATERS, AND TRAYS; SAND TOYS; TOY MAKE-UP SETS; KITS FOR BUILDING OUTDOOR PLAY EQUIPMENT; TOY MODEL HOBBYCRAFT KITS; TOY CARS; TOY SETS OF CARPENTERS' TOOLS; TOY OVENS; ROLE PLAYING TOYS IN THE NATURE OF TOY KITCHEN PLAY SETS AND TOY ACCESSORIES THEREFOR; ROLE PLAYING TOYS IN THE NATURE OF TOY NURSERY PLAY SETS AND TOY ACCESSORIES THEREFOR; DOLLS; ROLE PLAYING TOYS IN THE NATURE OF TOY JANITOR AND HOUSEKEEPING PLAYSETS AND ACCESSORIES THEREFOR; TOY SHOPPING CARTS; TOY STROLLERS; TOY WAGONS; TOY BOWLING BALLS AND PINS; TOY BOWLS; TOY BASKETS, NAMELY, TOY BOXES; TOY FLOWER POTS; TOY BUCKETS, NAMELY, TOY BOXES (U.S. CLS. 22, 23, 38 AND 50).

MICHAEL TANNER, EXAMINING ATTORNEY

SN 79-083,870. MINISTECK CREATIV GMBH, FED REP GERMANY, FILED 3-24-2010.



OWNER OF INTERNATIONAL REGISTRATION 1042364 DATED 3-24-2010, EXPIRES 3-24-2020.

OWNER OF U.S. REG. NOS. 3,090,464 AND 3,619,571.

NO CLAIM IS MADE TO THE EXCLUSIVE RIGHT TO USE "MINI BUILDER", APART FROM THE MARK AS SHOWN.

THE COLOR(S) RED, WHITE IS/ARE CLAIMED AS A FEATURE OF THE MARK.

THE MARK CONSISTS OF THE LETTER "M" AND THE WORDS "MINISTECK" AND "MINI BUILDER" WRITTEN IN A STYLISED MANNER, THE LETTERS BEING DESIGNED IN WHITE COLOR WITH RED EDGES.

FOR GAMES, PLAYTHINGS, NAMELY, TOY BUILDING BLOCKS CAPABLE OF INTERCONNECTION (U.S. CLS. 22, 23, 38 AND 50).

KRISTIN DAHLING, EXAMINING ATTORNEY



**CLASS 28—(Continued).**

SN 79-083,912. MINISTECK CREATIV GMBH, FED REP GERMANY, FILED 3-24-2010.



OWNER OF INTERNATIONAL REGISTRATION 1042501 DATED 3-24-2010, EXPIRES 3-24-2020.

OWNER OF U.S. REG. NOS. 3,090,464 AND 3,619,571.

NO CLAIM IS MADE TO THE EXCLUSIVE RIGHT TO USE "GIANT BUILDER", APART FROM THE MARK AS SHOWN.

THE COLOR(S) RED, WHITE IS/ARE CLAIMED AS A FEATURE OF THE MARK.

THE MARK CONSISTS OF THE LETTER "M" AND WORDS "MINISTECK" AND "GIANT BUILDER" IN A STYLISED DESIGN, THE LETTERS BEING DESIGNED IN WHITE COLOR WITH RED-COLORED EDGE; THE LETTER "M" AND THE WORDS "MINISTECK" AND "GIANT BUILDER" ARE PLACED ON A WHITE OVAL-SHAPED SURFACE WITH RED-COLORED EDGE.

FOR GAMES AND PLAYTHINGS, NAMELY, TOY BUILDING BLOCKS CAPABLE OF INTERCONNECTION (U.S. CLS. 22, 23, 38 AND 50).

KRISTIN DAHLING, EXAMINING ATTORNEY

**CLASS 28—(Continued).**

SN 85-007,129. EXTREME BUBBLES, INC., OYSTER CREEK, TX. FILED 4-6-2010.

**CAPTAIN BUBBLES**

THE MARK CONSISTS OF STANDARD CHARACTERS WITHOUT CLAIM TO ANY PARTICULAR FONT, STYLE, SIZE, OR COLOR.

FOR SCENTED AND UNSCENTED BUBBLE MAKING SOLUTIONS AND CONCENTRATES AND VARIOUS HAND HELD APPARATUS DESIGNED FOR PRODUCING BUBBLES (U.S. CLS. 22, 23, 38 AND 50).

KRISTINA MORRIS, EXAMINING ATTORNEY

SN 85-008,155. PURE FISHING, INC., SPIRIT LAKE, IA. FILED 4-7-2010.

**FLICKER STICK**

THE MARK CONSISTS OF STANDARD CHARACTERS WITHOUT CLAIM TO ANY PARTICULAR FONT, STYLE, SIZE, OR COLOR.

NO CLAIM IS MADE TO THE EXCLUSIVE RIGHT TO USE "STICK", APART FROM THE MARK AS SHOWN.

FOR ARTIFICIAL FISHING BAITS AND LURES (U.S. CLS. 22, 23, 38 AND 50).

RUDY R. SINGLETON, EXAMINING ATTORNEY

SN 79-084,279. FREINECKER, HELMUT, 82064 STRASLACH, FED REP GERMANY, FILED 2-26-2010.

**Tallabé**

THE MARK CONSISTS OF STANDARD CHARACTERS WITHOUT CLAIM TO ANY PARTICULAR FONT, STYLE, SIZE, OR COLOR.

PRIORITY DATE OF 8-28-2009 IS CLAIMED.

OWNER OF INTERNATIONAL REGISTRATION 1043341 DATED 2-26-2010, EXPIRES 2-26-2020.

FOR TRAINING HAT TO BE WORN ON THE HEAD FOR NECK AND SPINE SPORTS, EXERCISE, OR ATHLETICISM TRAINING PURPOSES; WEIGHTS FOR WEARING ON THE BODY FOR SPORTS, EXERCISE, OR ATHLETICISM TRAINING PURPOSES (U.S. CLS. 22, 23, 38 AND 50).

CORY BOONE, EXAMINING ATTORNEY

SN 85-011,528. POWIN CORPORATION, TIGARD, OR. FILED 4-12-2010.



THE COLOR(S) RED AND GOLD IS/ARE CLAIMED AS A FEATURE OF THE MARK.

THE MARK CONSISTS OF THE TEXT "GLADIATOR" IN BLACK WITH STYLIZED LETTER "A" AND "R" ACCOMPANIED BY A GOLD GLADIATOR'S HELMET WITH A RED PLUME.

FOR FITNESS MACHINES AND EQUIPMENT, NAMELY, WEIGHTS, TREADMILLS, ROWING MACHINES, STAIR STEPPING MACHINES, RESISTANCE MACHINES, STATIONARY CYCLES; MANUALLY-OPERATED EXERCISE EQUIPMENT FOR PHYSICAL FITNESS PURPOSES (U.S. CLS. 22, 23, 38 AND 50).

MICHELE SWAIN, EXAMINING ATTORNEY

SN 79-091,074. SAS AUPA, FRANCE, FILED 8-4-2010.

**SNIPER BODYBOARDS**

OWNER OF INTERNATIONAL REGISTRATION 0774511 DATED 9-25-2001, EXPIRES 9-25-2011.

NO CLAIM IS MADE TO THE EXCLUSIVE RIGHT TO USE "BODYBOARDS", APART FROM THE MARK AS SHOWN.

FOR BOARDS FOR BODYBOARDING USED FOR RIDING WAVES INCORPORATING A FIN AND LEASH (U.S. CLS. 22, 23, 38 AND 50).

APRIL ROACH, EXAMINING ATTORNEY

**CLASS 28—(Continued).**

SN 85-016,034. JEFF TATE, HARDINGSBURG, KY. FILED 4-16-2010.

**ACORN ADDICTION**

THE MARK CONSISTS OF STANDARD CHARACTERS WITHOUT CLAIM TO ANY PARTICULAR FONT, STYLE, SIZE, OR COLOR.

FOR ANIMAL ATTRACTANT SCENTS; DEER ATTRACTANTS (U.S. CLS. 22, 23, 38 AND 50).  
JANICE KIM, EXAMINING ATTORNEY

---

SN 85-026,948. EVANS, REINA, LONG BEACH, CA. FILED 4-30-2010.

**NATURES WAY TO PLAY**

THE MARK CONSISTS OF STANDARD CHARACTERS WITHOUT CLAIM TO ANY PARTICULAR FONT, STYLE, SIZE, OR COLOR.

FOR EDUCATIONAL TOYS FOR TEACHING EARLY CHILDHOOD DEVELOPMENT, SCIENCE, AND NATURE IN THE NATURE OF EARLY CHILDHOOD DEVELOPMENT SENSORY TABLES, SAND AND WATER TABLES, AND WOOD NATURE TABLES FOR CHILDREN AND EDUCATORS (U.S. CLS. 22, 23, 38 AND 50).  
KAPIL BHANOT, EXAMINING ATTORNEY

---

SN 85-028,441. PROMOUNDS, INC., BROCKTON, MA. FILED 5-3-2010.

**PROMOUNDS**

THE MARK CONSISTS OF STANDARD CHARACTERS WITHOUT CLAIM TO ANY PARTICULAR FONT, STYLE, SIZE, OR COLOR.

SEC. 2(F).  
FOR PORTABLE BASEBALL PITCHING MOUNDS, MATS FOR PITCHING SOFTBALLS, AND BASEBALL PITCHING PLATFORMS (U.S. CLS. 22, 23, 38 AND 50).  
FIRST USE 3-7-2001; IN COMMERCE 3-7-2001.  
SUE LAWRENCE, EXAMINING ATTORNEY

**CLASS 28—(Continued).**

SN 85-029,049. PARK & SUN INC., ENGLEWOOD, CO. FILED 5-3-2010.

**PARK & SUN SPORTS**

THE MARK CONSISTS OF STANDARD CHARACTERS WITHOUT CLAIM TO ANY PARTICULAR FONT, STYLE, SIZE, OR COLOR.

OWNER OF U.S. REG. NO. 2,836,116.  
NO CLAIM IS MADE TO THE EXCLUSIVE RIGHT TO USE "SPORTS", APART FROM THE MARK AS SHOWN.

FOR VOLLEYBALL AND BADMINTON GAME PLAYING EQUIPMENT; FIELD EQUIPMENT, NAMELY, FIELD MARKERS IN THE NATURE OF CORNER FLAGS AND CONES FOR MARKING THE AREAS OF A PLAYING FIELD, BOUNDARIES IN THE NATURE OF STAKES AND WEBBING AND/OR ROPE FOR DEFINING THE PLAYING AREA FOR VOLLEYBALL OR BADMINTON COURTS, AND SCREENS FOR USE AS BALL STOPS FOR BASEBALLS, SOFTBALLS, LACROSSE BALLS, VOLLEYBALLS OR SOCCER BALLS, SCREENS FOR USE AS BACK WALLS OF A PLAYING FIELD OR COURT, AND SCREENS FOR USE AS DIVIDERS BETWEEN TWO OR MORE PLAYING FIELDS OR COURTS; TETHERBALL GAME PLAYING EQUIPMENT; SOCCER, LACROSSE AND HOCKEY GOAL SETS; GAME TABLES; TOSSING DISC TOYS; BASEBALL, SOFTBALL, SOCCER, TENNIS, VOLLEYBALL, LACROSSE AND FOOTBALL TRAINING APPARATUS IN THE NATURE OF A TARGET CATCH NET USED TO IMPROVE AIM; STORAGE RACKS FOR SPORTS BALLS AND SPORTS EQUIPMENT (U.S. CLS. 22, 23, 38 AND 50).

FIRST USE 0-0-1995; IN COMMERCE 0-0-1995.  
BILL DAWE, EXAMINING ATTORNEY

---

SN 85-038,610. MATTEL, INC., EL SEGUNDO, CA. FILED 5-14-2010.

**COPTER CHASE**

THE MARK CONSISTS OF STANDARD CHARACTERS WITHOUT CLAIM TO ANY PARTICULAR FONT, STYLE, SIZE, OR COLOR.

NO CLAIM IS MADE TO THE EXCLUSIVE RIGHT TO USE "COPTER", APART FROM THE MARK AS SHOWN.  
FOR TOYS, GAMES AND PLAYTHINGS, NAMELY, TOY VEHICLES AND ACCESSORIES THEREFOR; TOY VEHICLE PLAYSETS AND ACCESSORIES THEREFOR (U.S. CLS. 22, 23, 38 AND 50).  
LINDSEY RUBIN, EXAMINING ATTORNEY

**CLASS 28—(Continued).**

SN 85-038,619. MATTEL, INC., EL SEGUNDO, CA. FILED 5-14-2010.

# SINGING STAR

THE MARK CONSISTS OF STANDARD CHARACTERS WITHOUT CLAIM TO ANY PARTICULAR FONT, STYLE, SIZE, OR COLOR.

OWNER OF U.S. REG. NO. 2,851,882.  
NO CLAIM IS MADE TO THE EXCLUSIVE RIGHT TO USE "SINGING", APART FROM THE MARK AS SHOWN.

FOR TOYS, GAMES AND PLAYTHINGS, NAMELY, DOLLS, DOLL CLOTHING AND DOLL ACCESSORIES; TOY FIGURES AND ACCESSORIES THEREFOR (U.S. CLS. 22, 23, 38 AND 50).

LINDSEY RUBIN, EXAMINING ATTORNEY

**CLASS 28—(Continued).**

SN 85-052,106. MATTEL, INC., EL SEGUNDO, CA. FILED 6-1-2010.

# CAR LOT CRASH PACK

THE MARK CONSISTS OF STANDARD CHARACTERS WITHOUT CLAIM TO ANY PARTICULAR FONT, STYLE, SIZE, OR COLOR.

NO CLAIM IS MADE TO THE EXCLUSIVE RIGHT TO USE "CAR LOT" AND "PACK", APART FROM THE MARK AS SHOWN.

FOR TOY VEHICLE PLAYSETS AND ACCESSORIES THEREFOR (U.S. CLS. 22, 23, 38 AND 50).

FIRST USE 2-16-2011; IN COMMERCE 2-16-2011.  
JOHN DALIER, EXAMINING ATTORNEY

SN 85-052,086. MATTEL, INC., EL SEGUNDO, CA. FILED 6-1-2010.

# SPINE BUSTER

THE MARK CONSISTS OF STANDARD CHARACTERS WITHOUT CLAIM TO ANY PARTICULAR FONT, STYLE, SIZE, OR COLOR.

OWNER OF U.S. REG. NO. 3,139,998.  
FOR TOY ACTION FIGURES AND ACCESSORIES THEREFOR (U.S. CLS. 22, 23, 38 AND 50).

FIRST USE 2-7-2011; IN COMMERCE 2-7-2011.  
KATHERINE CHANG, EXAMINING ATTORNEY

SN 85-052,108. MATTEL, INC., EL SEGUNDO, CA. FILED 6-1-2010.

# TIRE SHOP CRASH PACK

THE MARK CONSISTS OF STANDARD CHARACTERS WITHOUT CLAIM TO ANY PARTICULAR FONT, STYLE, SIZE, OR COLOR.

NO CLAIM IS MADE TO THE EXCLUSIVE RIGHT TO USE "TIRE SHOP" AND "PACK", APART FROM THE MARK AS SHOWN.

FOR TOY VEHICLE PLAYSETS AND ACCESSORIES THEREFOR (U.S. CLS. 22, 23, 38 AND 50).

FIRST USE 2-16-2011; IN COMMERCE 2-16-2011.  
JOHN DALIER, EXAMINING ATTORNEY

SN 85-052,101. MATTEL, INC., EL SEGUNDO, CA. FILED 6-1-2010.

# JET PACK BLAST

THE MARK CONSISTS OF STANDARD CHARACTERS WITHOUT CLAIM TO ANY PARTICULAR FONT, STYLE, SIZE, OR COLOR.

NO CLAIM IS MADE TO THE EXCLUSIVE RIGHT TO USE "JET PACK", APART FROM THE MARK AS SHOWN.

FOR TOY ACTION FIGURES AND ACCESSORIES THEREFOR (U.S. CLS. 22, 23, 38 AND 50).

FIRST USE 2-7-2011; IN COMMERCE 2-7-2011.  
KATHERINE CHANG, EXAMINING ATTORNEY

SN 85-052,109. MATTEL, INC., EL SEGUNDO, CA. FILED 6-1-2010.

# TOON'D MUSCLE

THE MARK CONSISTS OF STANDARD CHARACTERS WITHOUT CLAIM TO ANY PARTICULAR FONT, STYLE, SIZE, OR COLOR.

OWNER OF U.S. REG. NO. 3,077,469.  
NO CLAIM IS MADE TO THE EXCLUSIVE RIGHT TO USE "MUSCLE", APART FROM THE MARK AS SHOWN.

FOR TOY VEHICLES AND ACCESSORIES THEREFOR (U.S. CLS. 22, 23, 38 AND 50).

FIRST USE 2-16-2011; IN COMMERCE 2-16-2011.  
JOHN DALIER, EXAMINING ATTORNEY

**CLASS 28—(Continued).**

SN 85-052,479. RMS INTERNATIONAL (USA) INC., MIAMI, FL. FILED 6-2-2010.



THE COLOR(S) WHITE, ORANGE, RED, BLUE, GREEN, PURPLE AND YELLOW IS/ARE CLAIMED AS A FEATURE OF THE MARK.

THE MARK CONSISTS OF SEVERAL RECTANGULAR-LIKE SHAPES IN THE COLORS WHITE, RED, ORANGE, YELLOW, GREEN, BLUE AND PURPLE IN A RAINBOW PATTERN, WITH THE WORD "GRAFIX" SHOWN IN WHITE AND OUTLINED IN PURPLE SUPERIMPOSED OVER THE RAINBOW DESIGN.

FOR TOY MODEL HOBBY CRAFT KITS FOR CONSTRUCTING TOY MODEL VEHICLES, SCENERY, AND ACTION FIGURES; CONSTRUCTION TOYS; TOY MODELING DOUGH; TOY STAMPS; BATH TOYS; PUZZLES; PUZZLE GAMES; TRADING CARD GAMES; BOARD GAMES; PLAYING CARDS; DOMINOES; CHESS SETS; TOY VEHICLES; MECHANICAL TOYS; TOY ANIMALS; PLASTIC CHARACTER TOYS; TARGET GAMES; CHILDREN'S MULTIPLE ACTIVITY TOYS; OUTDOOR ACTIVITY TOYS AND GAMES, NAMELY, PLASTIC TOY HOOPS, FLYING SAUCERS, BADMINTON SETS, JUMP ROPES, BALLS FOR GAMES, BALLS FOR SPORTS; PUPPETS; DOLLS AND ACCESSORIES THEREFOR; BUBBLE MAKING WAND AND SOLUTION SETS; EGG DECORATING KITS; SKITTLES; PARTY FAVORS IN THE NATURE OF CRACKERS OR NOISEMAKERS; PARTY FAVORS IN THE NATURE OF SMALL TOYS; TOY NOISEMAKERS; CHRISTMAS TREE ORNAMENTS, CHRISTMAS STOCKINGS, CHRISTMAS TREE DECORATIONS; COSTUME MASKS (U.S. CLS. 22, 23, 38 AND 50).

PAM WILLIS, EXAMINING ATTORNEY

**CLASS 28—(Continued).**

SN 85-069,632. DISNEY ONLINE STUDIOS CANADA INC., VANCOUVER, CANADA, FILED 6-23-2010.

## CADENCE

THE MARK CONSISTS OF STANDARD CHARACTERS WITHOUT CLAIM TO ANY PARTICULAR FONT, STYLE, SIZE, OR COLOR.

FOR ACTION SKILL GAMES; ACTION FIGURES AND ACCESSORIES THEREFOR; BOARD GAMES; CARD GAMES; CHILDREN'S MULTIPLE ACTIVITY TOYS; BALLOONS; BATH TOYS; BEAN BAGS; BEAN BAG DOLLS; TOY BUILDING BLOCKS; BUBBLE MAKING WANDS AND SOLUTION SETS; CHESS SETS; CHILDREN'S PLAY COSMETICS; CHRISTMAS STOCKINGS; CHRISTMAS TREE ORNAMENTS AND DECORATIONS; COLLECTABLE TOY FIGURES; CRIB MOBILES; CRIB TOYS; DISC TOSS TOYS; DOLLS; DOLL CLOTHING; DOLL ACCESSORIES; DOLL PLAYSETS; ELECTRIC ACTION TOYS; EQUIPMENT SOLD AS A UNIT FOR PLAYING CARD GAMES; HAND-HELD UNITS FOR PLAYING ELECTRONIC GAMES OTHER THAN THOSE ADAPTED FOR USE WITH AN EXTERNAL DISPLAY SCREEN OR MONITOR; INFLATABLE TOYS; JIGSAW PUZZLES; KITES; MAGIC TRICKS; MARBLES; MANIPULATIVE GAMES; MECHANICAL TOYS; MUSIC BOX TOYS; MUSICAL TOYS; PARLOR GAMES; PARTY FAVORS IN THE NATURE OF SMALL TOYS; PAPER PARTY HATS; PARTY GAMES; PLAYING CARDS; PLUSH TOYS; PUPPETS; SNOW GLOBES; SPINNING TOPS; SQUEEZE TOYS; STUFFED TOYS; TALKING TOYS; TARGET GAMES; TEDDY BEARS; TOY ACTION FIGURES AND ACCESSORIES THEREFOR; TOY BUCKET AND SHOVEL SETS; TOY MOBILES; TOY VEHICLES; TOY SCOOTERS; TOY CARS; TOY MODEL HOBBYCRAFT KITS; TOY FIGURES; TOY BANKS; TOY TRUCKS; TOY WATCHES; WIND-UP TOYS; YO-YOS (U.S. CLS. 22, 23, 38 AND 50).

ELIZABETH KAJUBI, EXAMINING ATTORNEY

SN 85-065,652. FORMATION MARKETING CANADA LTD., BURLINGTON, CANADA, FILED 6-17-2010.

## SPLASH IT

THE MARK CONSISTS OF STANDARD CHARACTERS WITHOUT CLAIM TO ANY PARTICULAR FONT, STYLE, SIZE, OR COLOR.

FOR INFLATABLE POOLS FOR RECREATIONAL USE; INFLATABLE SWIMMING POOLS; PLAY SWIMMING POOLS; SWIMMING AIDS, NAMELY, POOL RINGS, ARM FLOATS, FLOATATION AIDS, NAMELY, FLOATING LOUNGE CHAIRS AND SWIM FLOATS FOR RECREATIONAL USE (U.S. CLS. 22, 23, 38 AND 50).

MARLENE BELL, EXAMINING ATTORNEY

SN 85-075,346. MATTEL, INC., EL SEGUNDO, CA. FILED 6-30-2010.

## LAUNCHIN' ENTRANCE RING

THE MARK CONSISTS OF STANDARD CHARACTERS WITHOUT CLAIM TO ANY PARTICULAR FONT, STYLE, SIZE, OR COLOR.

NO CLAIM IS MADE TO THE EXCLUSIVE RIGHT TO USE "ENTRANCE RING", APART FROM THE MARK AS SHOWN.

FOR TOY ACTION FIGURES AND ACCESSORIES THEREFOR; TOY ACTION FIGURE PLAYSETS AND ACCESSORIES THEREFOR (U.S. CLS. 22, 23, 38 AND 50).

FIRST USE 11-11-2010; IN COMMERCE 11-11-2010.

JESSICA FATHY, EXAMINING ATTORNEY

**CLASS 28—(Continued).**

SN 85-084,279. HEARTLAND CONSUMER PRODUCTS, LLC, LAKEWOOD, OH. FILED 7-14-2010.

**TEXAS CUT-THROAT**

THE MARK CONSISTS OF STANDARD CHARACTERS WITHOUT CLAIM TO ANY PARTICULAR FONT, STYLE, SIZE, OR COLOR.

NO CLAIM IS MADE TO THE EXCLUSIVE RIGHT TO USE "CUT-THROAT", APART FROM THE MARK AS SHOWN.

FOR DICE AND GAMES, NAMELY, DICE GAMES, CARD GAMES AND POKER STYLE CARD GAMES (U.S. CLS. 22, 23, 38 AND 50).

MARK SPARACINO, EXAMINING ATTORNEY



SN 85-088,631. CROMMETT, JOE F., KIRBY, AR. FILED 7-20-2010.

**AIM "N" DRAIN**

THE MARK CONSISTS OF STANDARD CHARACTERS WITHOUT CLAIM TO ANY PARTICULAR FONT, STYLE, SIZE, OR COLOR.

NO CLAIM IS MADE TO THE EXCLUSIVE RIGHT TO USE "AIM", APART FROM THE MARK AS SHOWN.

FOR TARGETS (U.S. CLS. 22, 23, 38 AND 50).  
TRACY WHITTAKER-BROWN, EXAMINING ATTORNEY



SN 85-092,781. ANA G. ENRIQUEZ, KENNER, LA. FILED 7-26-2010.

**69FOREPLAY**

THE MARK CONSISTS OF STANDARD CHARACTERS WITHOUT CLAIM TO ANY PARTICULAR FONT, STYLE, SIZE, OR COLOR.

FOR CASINO GAMES, NAMELY, CARD GAMES (U.S. CLS. 22, 23, 38 AND 50).

AISHA CLARKE, EXAMINING ATTORNEY

**CLASS 28—(Continued).**

SN 85-112,876. LU LU SPORTS CORP., NAN TOU HSIEN, TAIWAN, FILED 8-21-2010.

**LU LU**

THE MARK CONSISTS OF STANDARD CHARACTERS WITHOUT CLAIM TO ANY PARTICULAR FONT, STYLE, SIZE, OR COLOR.

THE NAME DOES NOT IDENTIFY A PARTICULAR LIVING INDIVIDUAL.

FOR BODY TRAINING APPARATUS, BOXING GLOVES, SPORTS EQUIPMENT, NAMELY, ELBOW GUARDS AND ARM GUARDS; SHIN GUARDS, KNEE GUARDS, MEN'S ATHLETIC SUPPORTERS, PHYSICAL EXERCISING MACHINES FOR BOXING, NAMELY, PROTECTIVE PADDINGS WHICH ARE PARTS OF SPORTS SUITS, AND PUNCHING BAGS, SHIN GUARDS; AND SPORTS GLOVES, NAMELY, BOXING GLOVES, BATTING AND FOOTBALL GLOVES (U.S. CLS. 22, 23, 38 AND 50).

FIRST USE 3-3-2010; IN COMMERCE 3-3-2010.  
JOHN E. MICHOS, EXAMINING ATTORNEY



SN 85-121,056. HOT TOYS LIMITED, KOWLOON, HONG KONG, FILED 9-1-2010.



NO CLAIM IS MADE TO THE EXCLUSIVE RIGHT TO USE "TOYS", APART FROM THE MARK AS SHOWN.

THE MARK CONSISTS OF A STYLIZED FLAME BEHIND THE WORDS "HOT TOYS" IN STYLIZED LETTERS. THE TERM "HOT" APPEARS ABOVE THE TERM "TOYS".

FOR TOYS, NAMELY, COLLECTABLE TOY FIGURES AND ASSOCIATED TOY WEAPONS (U.S. CLS. 22, 23, 38 AND 50).

FIRST USE 1-0-2000; IN COMMERCE 1-0-2000.  
MARLENE BELL, EXAMINING ATTORNEY

**CLASS 28—(Continued).**

SN 85-121,122. HOT TOYS LIMITED, KOWLOON, HONG KONG, FILED 9-1-2010.



NO CLAIM IS MADE TO THE EXCLUSIVE RIGHT TO USE "MOVIE", APART FROM THE MARK AS SHOWN.

THE MARK CONSISTS OF THE STYLIZED WORDS "MOVIE MASTERPIECE" SUPER-IMPOSED OVER A 3-DIMENSIONAL STAR AND SURROUNDED BY THREE SMALLER STARS, ONE TO THE LEFT OF THE TERM "MOVIE" AND TWO TO THE RIGHT OF THE TERM "MOVIE". THE TERM "MOVIE" APPEARS ABOVE THE TERM "MASTERPIECE".

FOR TOYS, NAMELY, COLLECTABLE TOY FIGURES AND ASSOCIATED TOY WEAPONS (U.S. CLS. 22, 23, 38 AND 50).

FIRST USE 1-0-2005; IN COMMERCE 1-0-2005.  
MARLENE BELL, EXAMINING ATTORNEY

SN 85-123,954. THREE SPOILED BRATS, INC., JERICHO, NY. FILED 9-7-2010.

## Pig-E-Skin

THE MARK CONSISTS OF STANDARD CHARACTERS WITHOUT CLAIM TO ANY PARTICULAR FONT, STYLE, SIZE, OR COLOR.

FOR FOAM BALLS FOR SPORTS; FOAM FOOT BALLS; FOAM FOOTBALLS; FOAM SPORT BALLS (U.S. CLS. 22, 23, 38 AND 50).

FIRST USE 2-14-2010; IN COMMERCE 2-14-2010.  
AMEEN IMAM, EXAMINING ATTORNEY

**CLASS 28—(Continued).**

SN 85-141,729. POLARIS INDUSTRIES INC., MEDINA, MN. FILED 9-30-2010.

## OUTLAW

THE MARK CONSISTS OF STANDARD CHARACTERS WITHOUT CLAIM TO ANY PARTICULAR FONT, STYLE, SIZE, OR COLOR.

OWNER OF U.S. REG. NO. 3,259,265.  
FOR RIDE ON TOYS IN THE SHAPE OF ALL-TERRAIN VEHICLES (U.S. CLS. 22, 23, 38 AND 50).

FIRST USE 6-0-2007; IN COMMERCE 6-0-2007.  
VIVIAN MICZNIK FIRST, EXAMINING ATTORNEY

SN 85-146,004. TOY STATE INDUSTRIAL LTD., TSIMSHAT-SUI, KOWLOON, HONG KONG, FILED 10-6-2010.

## RUMBLE 'N DUMP TRUCK

THE MARK CONSISTS OF STANDARD CHARACTERS WITHOUT CLAIM TO ANY PARTICULAR FONT, STYLE, SIZE, OR COLOR.

NO CLAIM IS MADE TO THE EXCLUSIVE RIGHT TO USE "DUMP TRUCK", APART FROM THE MARK AS SHOWN.

FOR TOY VEHICLES (U.S. CLS. 22, 23, 38 AND 50).  
TINA MAI, EXAMINING ATTORNEY

SN 85-146,018. TOY STATE INDUSTRIAL LTD., TSIMSHAT-SUI, KOWLOON, HONG KONG, FILED 10-6-2010.

## MEGA POWER DUMP TRUCK

THE MARK CONSISTS OF STANDARD CHARACTERS WITHOUT CLAIM TO ANY PARTICULAR FONT, STYLE, SIZE, OR COLOR.

NO CLAIM IS MADE TO THE EXCLUSIVE RIGHT TO USE "DUMP TRUCK", APART FROM THE MARK AS SHOWN.

FOR TOY VEHICLES (U.S. CLS. 22, 23, 38 AND 50).  
TINA MAI, EXAMINING ATTORNEY

**CLASS 28—(Continued).**

SN 85-149,093. EMGIE, INC., LOS ANGELES, CA. FILED 10-9-2010.

**BEAR CRIMBO**

THE MARK CONSISTS OF STANDARD CHARACTERS WITHOUT CLAIM TO ANY PARTICULAR FONT, STYLE, SIZE, OR COLOR.

NO CLAIM IS MADE TO THE EXCLUSIVE RIGHT TO USE "BEAR", APART FROM THE MARK AS SHOWN.

FOR TOYS, NAMELY, INFLATABLE TOYS, STUFFED TOYS, PLUSH TOYS; YO YOS, DOLLS; CHRISTMAS TREE ORNAMENTS; JIGSAW PUZZLES, KITES, PLAYING CARDS, CARD GAMES; BOARD GAMES (U.S. CLS. 22, 23, 38 AND 50).

GEOFFREY FOSDICK, EXAMINING ATTORNEY

SN 85-153,014. GOG PAINTBALL, S.A., SAN JOSE, COSTA RICA, FILED 10-14-2010.

**eNVy**

THE MARK CONSISTS OF STANDARD CHARACTERS WITHOUT CLAIM TO ANY PARTICULAR FONT, STYLE, SIZE, OR COLOR.

FOR SPORTS EQUIPMENT FOR THE SPORT OF PAINT BALL, NAMELY, PAINT BALL GUNS AND COMPONENTS AND ACCESSORIES FOR PAINT BALL GUNS, NAMELY, GRIPS AND GRIP FRAMES FOR PAINT BALL GUNS; PAINT BALL GUN BARRELS, BARREL COVERS, BARREL PLUGS AND REGULATORS SOLD AS A UNIT (U.S. CLS. 22, 23, 38 AND 50).

NAAKWAMA ANKRAH, EXAMINING ATTORNEY

SN 85-153,980. ATOLL HOLDINGS, INC., SAN LUIS OBISPO, CA. FILED 10-15-2010.

**2X4 Fitness**

THE MARK CONSISTS OF STANDARD CHARACTERS WITHOUT CLAIM TO ANY PARTICULAR FONT, STYLE, SIZE, OR COLOR.

NO CLAIM IS MADE TO THE EXCLUSIVE RIGHT TO USE "FITNESS", APART FROM THE MARK AS SHOWN.

FOR EXERCISE EQUIPMENT, NAMELY, A POLE CONFIGURED FOR ISOMETRIC EXERCISE (U.S. CLS. 22, 23, 38 AND 50).

MARIA-VICTORIA SUAREZ, EXAMINING ATTORNEY

**CLASS 28—(Continued).**

SN 85-154,830. MEDI IP LLC, TAMPA, FL. FILED 10-18-2010.

**InterActive Exercise**

NO CLAIM IS MADE TO THE EXCLUSIVE RIGHT TO USE "EXERCISE", APART FROM THE MARK AS SHOWN.

THE MARK CONSISTS OF THE WORDS "INTERACTIVE EXERCISE" APPEARING OVER A TRIANGLE WHICH GETS WIDER FROM LEFT TO RIGHT.

FOR EXERCISE DEVICES, NAMELY, MANUALLY OPERATED RESISTIVE EXERCISE BANDS, TUBES, CORDS, BALLS; WEIGHTED BARS (U.S. CLS. 22, 23, 38 AND 50).

KAREN BRACEY, EXAMINING ATTORNEY

SN 85-155,556. SOUTH BAY SPORTS AND ENTERTAINMENT, LLC, DBA JK SURFBOARDS, MANHATTAN BEACH, CA. FILED 10-18-2010.



NO CLAIM IS MADE TO THE EXCLUSIVE RIGHT TO USE "CALIFORINA", APART FROM THE MARK AS SHOWN.

THE COLOR(S) RED, WHITE, BLUE AND BLACK IS/ARE CLAIMED AS A FEATURE OF THE MARK.

THE MARK CONSISTS OF A VERTICAL RECTANGLE THAT IS DIVIDED IN HALF WITH THE LEFT HALF APPEARING IN RED AND THE RIGHT HALF APPEARING IN BLUE. THE RECTANGLES ARE OUTLINED IN WHITE AND THEN IN A THIN BLACK LINE THAT IS BROKEN IN SEVERAL PLACES. THE DESIGN OF A MAN RIDING A SURFBOARD ALL IN BLACK IS SUPERIMPOSED OVER THE RECTANGLE. UNDERNEATH THE DESIGN IS THE TERM "SACRED" IN WHITE STYLIZED SCRIPT AND OUTLINED IN BLACK AND THE TERM "CALIFORNIA" APPEARS BELOW THAT IN BLACK AND OUTLINED IN WHITE.

FOR BAGS ESPECIALLY DESIGNED FOR SURFBOARDS; BINDINGS FOR SNOWBOARDS; HARNESSES SPECIALLY ADAPTED FOR CARRYING SNOWBOARDS, SKIS AND SKATEBOARDS; KITE BOARDS; KITE BOARD HANDLES; KITE BOARD LINES; KITE BOARD REELS; KITE BOARD STRING; KITS FOR BUILDING SURFBOARDS; LEASHES FOR SURFBOARDS; PADDLE BOARDS; PADDLE SURFBOARDS; PADDLES FOR USE IN PADDLE BALL GAMES; PADDLES FOR USE WITH SURFBOARDS; PROTECTIVE PADDING FOR SNOWBOARDING; SNOWBOARD BINDINGS; SNOWBOARD DECKS; SNOWBOARD WAX; SNOWBOARDS; STAND-UP SURF PADDLES; SURF PADDLES; SURFBOARD CARRIER WORN ON THE BODY; SURFBOARD FINS; SURFBOARD HOLDER WORN ON THE BODY; SURFBOARD LEASHES; SURFBOARD REPAIR PATCHES; SURFBOARD STORAGE RACK; SURFBOARD TRACTION PADS; SURFBOARD WAX; SURFBOARDS; TRACTION PADS FOR SURFBOARDS; WAXING BRUSHES FOR SKIING AND SNOWBOARDING (U.S. CLS. 22, 23, 38 AND 50).

ELLEN PERKINS, EXAMINING ATTORNEY

**CLASS 28—(Continued).**

SN 85-155,596. TAN XIAO MING, GUANGDONG PROVINCE, CHINA, FILED 10-19-2010.

POPOBE

THE WORDING "POPOBE" HAS NO MEANING IN A FOREIGN LANGUAGE.

FOR BALLS FOR GAMES; BODY-TRAINING APPARATUS; CHESS GAMES; EXERCISE MACHINES; PLAY SWIMMING POOLS; PLAYING CARDS; PROTECTIVE SUPPORTS FOR SHOULDERS AND ELBOWS; PUZZLE GAMES; TOY BUILDING BLOCKS; TOY FIGURES (U.S. CLS. 22, 23, 38 AND 50).

RONALD MCMORROW, EXAMINING ATTORNEY

**CLASS 28—(Continued).**

SN 85-157,920. OLLINGER, CHARLES, KINGSTON, MA. FILED 10-21-2010.

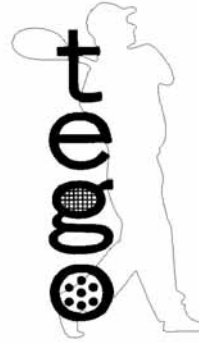

THE MARK CONSISTS OF THE WORD "TEGO" WRITTEN VERTICALLY IN STYLIZED TEXT WITH THE TOP PART OF THE "G" APPEARING AS A TENNIS RACQUET FACE AND THE "O" APPEARING AS A GOLF BALL. THERE IS A SILHOUETTE OF A MAN HOLDING A RACQUET BEHIND THE WORDING.

FOR GAME EQUIPMENT, NAMELY, A BALL AND RACQUET FOR USE IN A GOLF/TENNIS HYBRID GAME SOLD AS A UNIT (U.S. CLS. 22, 23, 38 AND 50).  
DAWN FELDMAN, EXAMINING ATTORNEY

SN 85-157,261. GOLDSTEIN COLUMBIA, LLC, RIDGEFIELD, CT. FILED 10-20-2010.

PERFECT WHEN PARALLEL

THE MARK CONSISTS OF STANDARD CHARACTERS WITHOUT CLAIM TO ANY PARTICULAR FONT, STYLE, SIZE, OR COLOR.

FOR GOLF TRAINING APPARATUS, NAMELY, STRIPS ATTACHED TO GOLF SHOES USED TO HELP ALIGN FOOT PLACEMENT TO IMPROVE GOLF STANCES (U.S. CLS. 22, 23, 38 AND 50).

TEJBIR SINGH, EXAMINING ATTORNEY

SN 85-159,702. SCOTT LUCAS, CORONA DEL MAR, CA. FILED 10-23-2010.

Drain - O

THE MARK CONSISTS OF STANDARD CHARACTERS WITHOUT CLAIM TO ANY PARTICULAR FONT, STYLE, SIZE, OR COLOR.

FOR GOLF PUTTING AIDS, NAMELY, CLUB ATTACHMENT DEVICE THAT GUIDES AND IMPROVES A PUTTING STROKE (U.S. CLS. 22, 23, 38 AND 50).

FIRST USE 9-30-2010; IN COMMERCE 1-29-2011.  
GENE MACIOL, EXAMINING ATTORNEY



**CLASS 28—(Continued).**

SN 85-161,788. INSECT LORE PRODUCTS, SHAFTER, CA. FILED 10-26-2010.

# CAMPFIRE KIDS

THE MARK CONSISTS OF STANDARD CHARACTERS WITHOUT CLAIM TO ANY PARTICULAR FONT, STYLE, SIZE, OR COLOR.

NO CLAIM IS MADE TO THE EXCLUSIVE RIGHT TO USE "KIDS", APART FROM THE MARK AS SHOWN.

FOR TOY CAMPING EQUIPMENT, NAMELY, PLAY TENTS, ARTIFICIAL TOY CAMPFIRE, TOY FRYING PAN SETS, TOY BARBEQUE FORK SETS, TOY BEAR-SKIN RUGS, TOY LOG CHOPPING SETS COMPRISING TOY AXE AND PLASTIC LOG, SIMULATED TREE STUMP STOOLS, TOY ROCKS WITH NIGHTTIME SOUNDS, TOY MARSHMALLOW ROASTING STICKS, TOY HOT DOG ROASTING STICKS, TOY CAMPING LANTERNS, CAMP KNOT TYING KITS, TOY CANTEENS, PLAY RACCOON SKIN CAPS, TOY LIGHT UP PINE CONES, TOY WOOD CARVING SETS, TOY COMPASSES, TOY SURVIVAL KITS, TOY MOON IMAGE CEILING PROJECTORS, TOY LIGHT UP FIREFLY JARS AND TOY FISHING POLES (U.S. CLS. 22, 23, 38 AND 50).  
JORDAN BAKER, EXAMINING ATTORNEY

**CLASS 28—(Continued).**

SN 85-172,360. AGEWELL, LLC, INDIANAPOLIS, IN. FILED 11-9-2010.

# AGEWELL

THE MARK CONSISTS OF STANDARD CHARACTERS WITHOUT CLAIM TO ANY PARTICULAR FONT, STYLE, SIZE, OR COLOR.

OWNER OF U.S. REG. NOS. 1,920,595, 2,102,654 AND OTHERS.

FOR JIGSAW PUZZLES; CARD GAMES, TILE GAMES; BOARD GAMES; PUZZLE GAMES (U.S. CLS. 22, 23, 38 AND 50).

SUSAN RICHARDS, EXAMINING ATTORNEY

SN 85-172,370. AGEWELL, LLC, INDIANAPOLIS, IN. FILED 11-9-2010.

# MEMORY MAKEOVER

THE MARK CONSISTS OF STANDARD CHARACTERS WITHOUT CLAIM TO ANY PARTICULAR FONT, STYLE, SIZE, OR COLOR.

OWNER OF U.S. REG. NO. 3,576,573.

FOR JIGSAW PUZZLES; CARD GAMES, TILE GAMES; BOARD GAMES; PUZZLE GAMES (U.S. CLS. 22, 23, 38 AND 50).

SUSAN RICHARDS, EXAMINING ATTORNEY

SN 85-171,365. BRIDGESTONE SPORTS CO., LTD, TOKYO, JAPAN, FILED 11-8-2010.



THE MARK CONSISTS OF A PARTIAL OVAL WITH A DIAGONAL LINE INTERSECTING THEREWITH, AND A CRESCENT SHAPE APPEARS UNDERNEATH THE OVAL.

FOR GOLF EQUIPMENT, NAMELY, GOLF BALLS, GOLF CLUBS, GOLF CLUB HEAD COVERS, GOLF BAGS, GOLF GLOVES (U.S. CLS. 22, 23, 38 AND 50).

ANDREW LEASER, EXAMINING ATTORNEY

SN 85-173,017. SAMPEY, DWAIN, GOLDONNA, LA. FILED 11-9-2010.



THE MARK CONSISTS OF A TREE FOLLOWED BY THE LETTERS "REE-D".

FOR HUNTING ACCESSORY, NAMELY, ARTIFICIAL TREE BRANCHES THAT SCREW INTO LIVE TREES FOR HUNTING CONCEALMENT (U.S. CLS. 22, 23, 38 AND 50).

KATHLEEN LORENZO, EXAMINING ATTORNEY

**CLASS 28—(Continued).**

SN 85-173,489. ALL THINGS EQUAL, MIAMI BEACH, FL. FILED 11-10-2010.

**THE BEST DAY EVER!**

THE MARK CONSISTS OF STANDARD CHARACTERS WITHOUT CLAIM TO ANY PARTICULAR FONT, STYLE, SIZE, OR COLOR.  
FOR BOARD GAMES (U.S. CLS. 22, 23, 38 AND 50).  
BRENDAN REGAN, EXAMINING ATTORNEY

**CLASS 28—(Continued).**

SN 85-176,119. OBEROI, OBIE, ARLINGTON, TX. FILED 11-13-2010.

**Sky Invaders**

THE MARK CONSISTS OF STANDARD CHARACTERS WITHOUT CLAIM TO ANY PARTICULAR FONT, STYLE, SIZE, OR COLOR.  
FOR RADIO CONTROLLED TOYS, NAMELY, HELICOPTERS (U.S. CLS. 22, 23, 38 AND 50).  
FIRST USE 12-1-2007; IN COMMERCE 9-1-2008.  
MATTHEW PAPPAS, EXAMINING ATTORNEY

SN 85-173,548. THE OHIO ART COMPANY, BRYAN, OH. FILED 11-10-2010.

**GIGGLE BELLIES**

THE MARK CONSISTS OF STANDARD CHARACTERS WITHOUT CLAIM TO ANY PARTICULAR FONT, STYLE, SIZE, OR COLOR.  
FOR DRAWING TOYS (U.S. CLS. 22, 23, 38 AND 50).  
FIRST USE 9-14-2010; IN COMMERCE 9-14-2010.  
DAVID TAYLOR, EXAMINING ATTORNEY

SN 85-176,385. THE KAYO CORP, CARLSBAD, CA. FILED 11-15-2010.

SN 85-174,995. USA HOCKEY, INC., COLORADO SPRINGS, CO. FILED 11-11-2010.

**DA PLAYGROUND****MIRACLE ON ICE**

THE MARK CONSISTS OF STANDARD CHARACTERS WITHOUT CLAIM TO ANY PARTICULAR FONT, STYLE, SIZE, OR COLOR.  
OWNER OF U.S. REG. NOS. 3,101,193 AND 3,848,129.  
FOR TOYS, GAMES AND SPORTS EQUIPMENT, NAMELY, TABLE GAMES WITH MOVABLE PARTS FOR PLAYING SPORT ACTION SKILL GAMES (U.S. CLS. 22, 23, 38 AND 50).  
MICHELE SWAIN, EXAMINING ATTORNEY

THE MARK CONSISTS OF STANDARD CHARACTERS WITHOUT CLAIM TO ANY PARTICULAR FONT, STYLE, SIZE, OR COLOR.  
FOR BALL BEARINGS FOR SKATEBOARDS; NUTS AND BOLTS FOR SKATEBOARDS; SKATEBOARD GRIP TAPES; SKATEBOARD RISER PADS; SKATEBOARD TRUCKS; SKATEBOARD WHEELS (U.S. CLS. 22, 23, 38 AND 50).  
KELLEY WELLS, EXAMINING ATTORNEY

**CLASS 28—(Continued).**

SN 85-176,396. GUANGZHOU RIDO FITNESS & SPORTS CO., LTD., GUANGZHOU, CHINA, FILED 11-15-2010.



THE MARK CONSISTS OF A DESIGNED TRIANGLE WITH A CURVED TAIL BENEATH AND DESIGNED WORDING "REGYM".

THE WORDING "REGYM" HAS NO MEANING IN A FOREIGN LANGUAGE.

FOR ARCHERY IMPLEMENTS; BALLS FOR SPORTS; BATTING GLOVES; BILLIARD TABLES; BODY-BUILDING APPARATUS; CLIMBERS' HARNESES; DUMBBELLS; EXERCISE BALLS; EXERCISE EQUIPMENT, NAMELY, ROWING MACHINES; EXERCISING EQUIPMENT, NAMELY, WEIGHT LIFTING MACHINES; GYMNASIUM APPARATUS; PLAY SWIMMING POOLS; PUNCHING BAGS; ROLLER AND ICE SKATES; SPORT BALLS; STATIONARY EXERCISE BICYCLES; TABLE TENNIS BATS; TOY WHISTLES; TRAMPOLINE BOUNCE BOARD (U.S. CLS. 22, 23, 38 AND 50).

FIRST USE 4-20-2010; IN COMMERCE 7-15-2010.  
LINDA LAVACHE, EXAMINING ATTORNEY

**CLASS 28—(Continued).**

SN 85-176,788. ROBERT RAY GRANT III, HUDSON, FL. FILED 11-15-2010.



NO CLAIM IS MADE TO THE EXCLUSIVE RIGHT TO USE "THE ORIGINAL", APART FROM THE MARK AS SHOWN.

THE MARK CONSISTS OF A DESIGN ELEMENT, SANDWICHED BETWEEN THE WORDS "TULEE" AND "LOOPA", CONSISTING OF TWO OVALS WITHIN TWO CIRCLES, THE CIRCLES AND OVALS BEING BISECTED BY A DIAGONAL LINE WITH AN OVAL AT THE TIP. THE WORDS "THE ORIGINAL" ARE ABOVE THE DESIGN ELEMENT.

FOR OUTDOOR ACTIVITY GAME CONSISTING OF A STICK AND LOOP USED TO HIT AND/OR REDIRECT THE LOOP WITH THE STICK (U.S. CLS. 22, 23, 38 AND 50).

JUSTINE D. PARKER, EXAMINING ATTORNEY

SN 85-177,032. ALLIED MATERIALS AND EQUIPMENT COMPANY, INC., KANSAS CITY, MO. FILED 11-15-2010.

I TAKE MY PIECES OF  
YESTERDAY AND PUT THEM  
INTO MY PUZZLE OF TOMORROW

SN 85-176,527. FOOTHILLS CREATONS LTD, BOULDER, CO. FILED 11-15-2010.

THE MARK CONSISTS OF STANDARD CHARACTERS WITHOUT CLAIM TO ANY PARTICULAR FONT, STYLE, SIZE, OR COLOR.

FOR JIGSAW PUZZLES (U.S. CLS. 22, 23, 38 AND 50).  
LAKEISHA LEWIS, EXAMINING ATTORNEY

BloodSuckers

SN 85-177,088. WOODWAY USA, INC., WAUKESHA, WI. FILED 11-15-2010.

4FRONT

THE MARK CONSISTS OF STANDARD CHARACTERS WITHOUT CLAIM TO ANY PARTICULAR FONT, STYLE, SIZE, OR COLOR.

FOR NOVELTY ITEMS, NAMELY, FAKE TEETH (U.S. CLS. 22, 23, 38 AND 50).  
FIRST USE 9-13-2010; IN COMMERCE 9-24-2010.  
JACLYN KIDWELL WALKER, EXAMINING ATTORNEY

THE MARK CONSISTS OF STANDARD CHARACTERS WITHOUT CLAIM TO ANY PARTICULAR FONT, STYLE, SIZE, OR COLOR.

FOR TREADMILLS (U.S. CLS. 22, 23, 38 AND 50).  
LESLIE RICHARDS, EXAMINING ATTORNEY

**CLASS 28—(Continued).**

SN 85-177,304. SHUFFLE MASTER INC, LAS VEGAS, NV.  
FILED 11-15-2010.

# MD2CR

THE MARK CONSISTS OF STANDARD CHARACTERS WITHOUT CLAIM TO ANY PARTICULAR FONT, STYLE, SIZE, OR COLOR.

FOR CASINO TABLE GAME EQUIPMENT, NAMELY, PLAYING CARD SHUFFLING DEVICES AND PARTS THEREFOR (U.S. CLS. 22, 23, 38 AND 50).

ALICE BENMAMAN, EXAMINING ATTORNEY

**CLASS 28—(Continued).**

SN 85-178,908. NELSON, DAVID, CALABASAS, CA. AND LUCAS, JOHN, CALABASAS, CA. FILED 11-17-2010.

# Big Mouth

THE MARK CONSISTS OF STANDARD CHARACTERS WITHOUT CLAIM TO ANY PARTICULAR FONT, STYLE, SIZE, OR COLOR.

FOR SOFTBALL AND BASEBALL PRACTICE NETS (U.S. CLS. 22, 23, 38 AND 50).

FIRST USE 4-27-2009; IN COMMERCE 4-27-2009.  
DARRYL SPRUILL, EXAMINING ATTORNEY

SN 85-177,982. TOY STATE INDUSTRIAL LTD., TSIMSHAT-SUI, KOWLOON, HONG KONG, FILED 11-16-2010.

# LOAD BLASTER

THE MARK CONSISTS OF STANDARD CHARACTERS WITHOUT CLAIM TO ANY PARTICULAR FONT, STYLE, SIZE, OR COLOR.

FOR TOY VEHICLES (U.S. CLS. 22, 23, 38 AND 50).  
NICHOLAS COLEMAN, EXAMINING ATTORNEY

SN 85-179,375. LITTLE, MARK WAYNE, VINCENNES, IN. FILED 11-17-2010.

# UGLY TED

THE MARK CONSISTS OF STANDARD CHARACTERS WITHOUT CLAIM TO ANY PARTICULAR FONT, STYLE, SIZE, OR COLOR.

FOR STUFFED AND PLUSH DOLLS; STUFFED AND PLUSH TOY ANIMALS (U.S. CLS. 22, 23, 38 AND 50).  
DOMINIC J. FERRAIUOLO, EXAMINING ATTORNEY

SN 85-178,565. DOING HIS WORK FIRST, INC., JACKSON, TN. FILED 11-17-2010.

# DOING HIS WORK FIRST

THE MARK CONSISTS OF STANDARD CHARACTERS WITHOUT CLAIM TO ANY PARTICULAR FONT, STYLE, SIZE, OR COLOR.

FOR MANUALLY-OPERATED EXERCISE EQUIPMENT FOR PHYSICAL FITNESS PURPOSES, RIDE-ON TOYS (U.S. CLS. 22, 23, 38 AND 50).

JOHN GARTNER, EXAMINING ATTORNEY

SN 85-179,406. REITER, MICHAEL J., SAN DIEGO, CA. FILED 11-17-2010.

# BUB'BLOOP!

THE MARK CONSISTS OF STANDARD CHARACTERS WITHOUT CLAIM TO ANY PARTICULAR FONT, STYLE, SIZE, OR COLOR.

FOR BATH TOYS; BUBBLE MAKING WAND AND SOLUTION SETS (U.S. CLS. 22, 23, 38 AND 50).  
FIRST USE 11-2-2010; IN COMMERCE 11-2-2010.

BERYL GARDNER, EXAMINING ATTORNEY

**CLASS 28—(Continued).**

SN 85-179,839. P. C. WOO, INC., DBA MEGATOYS, LOS ANGELES, CA. FILED 11-18-2010.

# FLAME THROWERZ

THE MARK CONSISTS OF STANDARD CHARACTERS WITHOUT CLAIM TO ANY PARTICULAR FONT, STYLE, SIZE, OR COLOR.  
FOR TOY VEHICLES (U.S. CLS. 22, 23, 38 AND 50).  
MICHAEL KEATING, EXAMINING ATTORNEY

---

SN 85-179,943. RANKINE, ROBERT, ST. AUGUSTINE, FL. AND HINMAN, BRYAN, ST. AUGUSTINE, FL. FILED 11-18-2010.

# DINOSCORE

THE MARK CONSISTS OF STANDARD CHARACTERS WITHOUT CLAIM TO ANY PARTICULAR FONT, STYLE, SIZE, OR COLOR.  
FOR GAME RANDOMIZER FOR RANDOMLY DETERMINING GAME PLAY IN A PARLOR GAME, SOLD AS A COMPONENT PART THEREOF (U.S. CLS. 22, 23, 38 AND 50).  
GISELLE AGOSTO, EXAMINING ATTORNEY

---

SN 85-180,250. NORWAY INDUSTRIES, INC., MYRTLE POINT, OR. FILED 11-18-2010.

# ZEON

THE MARK CONSISTS OF STANDARD CHARACTERS WITHOUT CLAIM TO ANY PARTICULAR FONT, STYLE, SIZE, OR COLOR.  
FOR ARCHERY EQUIPMENT, NAMELY, VANES FOR ARROWS (U.S. CLS. 22, 23, 38 AND 50).  
SUNG IN, EXAMINING ATTORNEY

**CLASS 28—(Continued).**

SN 85-180,620. LIOU, REN JEI, ROWLAND HEIGHTS, CA. FILED 11-18-2010.

# BANG

THE MARK CONSISTS OF STANDARD CHARACTERS WITHOUT CLAIM TO ANY PARTICULAR FONT, STYLE, SIZE, OR COLOR.  
FOR GOLF EQUIPMENT, NAMELY, GOLF CLUBS, GOLF CLUB HEADS, AND GOLF CLUB SHAFTS; AND GOLF ACCESSORIES, NAMELY, GOLF BAGS (U.S. CLS. 22, 23, 38 AND 50).  
GINA HAYES, EXAMINING ATTORNEY

---

SN 85-181,505. BARNETT OUTDOORS, LLC, TARPON SPRINGS, FL. FILED 11-19-2010.

# GAMECRUSHER

THE MARK CONSISTS OF STANDARD CHARACTERS WITHOUT CLAIM TO ANY PARTICULAR FONT, STYLE, SIZE, OR COLOR.  
FOR ARCHERY EQUIPMENT, NAMELY, ARROWS AND BROADHEADS (U.S. CLS. 22, 23, 38 AND 50).  
ELIZABETH KAJUBI, EXAMINING ATTORNEY

---

SN 85-182,523. HOBBY LOBBY STORES, INC., OKLAHOMA CITY, OK. FILED 11-22-2010.

# FAN FEVER

THE MARK CONSISTS OF STANDARD CHARACTERS WITHOUT CLAIM TO ANY PARTICULAR FONT, STYLE, SIZE, OR COLOR.  
FOR ARTIFICIAL CHRISTMAS TREES; CHRISTMAS STOCKINGS; CHRISTMAS TREE ORNAMENTS AND DECORATIONS; CHRISTMAS TREE SKIRTS (U.S. CLS. 22, 23, 38 AND 50).  
DEIRDRE ROBERTSON, EXAMINING ATTORNEY

**CLASS 28—(Continued).**

SN 85-183,705. TOY STATE INDUSTRIAL LTD., TSIMSHAT-SUI, KOWLOON, HONG KONG, FILED 11-23-2010.

**CONTROL FREAKZ**

THE MARK CONSISTS OF STANDARD CHARACTERS WITHOUT CLAIM TO ANY PARTICULAR FONT, STYLE, SIZE, OR COLOR.

FOR TOY VEHICLES (U.S. CLS. 22, 23, 38 AND 50).  
NICHOLAS COLEMAN, EXAMINING ATTORNEY

---

SN 85-199,012. DREAMWORKS ANIMATION L.L.C., GLENDALE, CA. FILED 12-15-2010.

**PUSS IN BOOTS**

THE MARK CONSISTS OF STANDARD CHARACTERS WITHOUT CLAIM TO ANY PARTICULAR FONT, STYLE, SIZE, OR COLOR.

OWNER OF U.S. REG. NO. 2,965,384.  
FOR ACTION FIGURES AND ACCESSORIES THEREFOR, BATHTUB TOYS, KITES, TOY BUILDING BLOCKS, BOARD GAMES, HAND-HELD UNIT FOR PLAYING ELECTRONIC GAMES OTHER THAN THOSE ADAPTED FOR USE WITH AN EXTERNAL DISPLAY SCREEN OR MONITOR, DIE CAST MINIATURE TOY VEHICLES, DOLL ACCESSORIES, DOLL CLOTHING, BEAN BAG DOLLS, BENDABLE PLAY FIGURES, FLYING DISCS, INFLATABLE VINYL PLAY FIGURES, JIGSAW PUZZLES, MARBLES, PUPPETS, RIDE-ON TOYS, SKATEBOARDS, BALLOONS, ROLLERSKATES, TOY BANKS, WATER SQUIRTING TOYS, STUFFED TOYS, TOY VEHICLES, CHRISTMAS TREE ORNAMENTS; PINBALL MACHINES AND MODEL CRAFT KITS OF TOY FIGURES (U.S. CLS. 22, 23, 38 AND 50).  
WON TEAK OH, EXAMINING ATTORNEY

---

SN 85-200,410. PURE FISHING, INC., SPIRIT LAKE, IA. FILED 12-17-2010.

**DEVIL SPIKE**

THE MARK CONSISTS OF STANDARD CHARACTERS WITHOUT CLAIM TO ANY PARTICULAR FONT, STYLE, SIZE, OR COLOR.

FOR ARTIFICIAL FISHING BAIT; FISHING TACKLE (U.S. CLS. 22, 23, 38 AND 50).  
JOHN DALIER, EXAMINING ATTORNEY

**CLASS 28—(Continued).**

SN 85-200,412. PURE FISHING, INC., SPIRIT LAKE, IA. FILED 12-17-2010.

**DEUCE TAIL**

THE MARK CONSISTS OF STANDARD CHARACTERS WITHOUT CLAIM TO ANY PARTICULAR FONT, STYLE, SIZE, OR COLOR.

FOR ARTIFICIAL FISHING BAIT; FISHING TACKLE (U.S. CLS. 22, 23, 38 AND 50).  
JOHN DALIER, EXAMINING ATTORNEY

---

SN 85-200,416. PURE FISHING, INC., SPIRIT LAKE, IA. FILED 12-17-2010.

**CRAW FATTY**

THE MARK CONSISTS OF STANDARD CHARACTERS WITHOUT CLAIM TO ANY PARTICULAR FONT, STYLE, SIZE, OR COLOR.

FOR ARTIFICIAL FISHING BAIT; FISHING TACKLE (U.S. CLS. 22, 23, 38 AND 50).  
JOHN DALIER, EXAMINING ATTORNEY

---

SN 85-202,015. FITNESS ANYWHERE, INC., SAN FRANCISCO, CA. FILED 12-20-2010.

**TRX FORCE**

THE MARK CONSISTS OF STANDARD CHARACTERS WITHOUT CLAIM TO ANY PARTICULAR FONT, STYLE, SIZE, OR COLOR.

OWNER OF U.S. REG. NOS. 3,202,696 AND 3,384,871.  
FOR MANUALLY-OPERATED EXERCISE EQUIPMENT (U.S. CLS. 22, 23, 38 AND 50).  
KEVIN DINALLO, EXAMINING ATTORNEY

**CLASS 28—(Continued).**

SN 85-207,559. GANZ, WOODBRIDGE, ONT, CANADA, FILED 12-29-2010.

**CLASS 28—(Continued).**

SN 85-218,301. MVL RIGHTS LLC, MANHATTAN BEACH, CA. FILED 1-14-2011.

# AMAZING WORLD

THE MARK CONSISTS OF STANDARD CHARACTERS WITHOUT CLAIM TO ANY PARTICULAR FONT, STYLE, SIZE, OR COLOR.

FOR PLUSH TOYS, CARD GAMES, BOARD GAMES, JIGSAW PUZZLES, CHRISTMAS TREE ORNAMENTS AND CHRISTMAS STOCKINGS, TOY CLOTHING FOR PLUSH TOYS, MODELED PLASTIC TOY FIGURINES, AND PLUSH TOY ACCESSORIES NAMELY, FURNITURE, JEWELRY, PET CARRIERS; STAND ALONE VIDEO GAME MACHINES, BATH TOYS; PARTY FAVORS IN THE NATURE OF SMALL TOYS AND NOISE-MAKERS (U.S. CLS. 22, 23, 38 AND 50).  
JENNY PARK, EXAMINING ATTORNEY

# ANT-MAN

SN 85-209,782. TOY STATE INDUSTRIAL LTD., TSIMSHAT-SUI, KOWLOON, HONG KONG, FILED 1-4-2011.

# RIM ROCKERZ

THE MARK CONSISTS OF STANDARD CHARACTERS WITHOUT CLAIM TO ANY PARTICULAR FONT, STYLE, SIZE, OR COLOR.

OWNER OF U.S. REG. NO. 3,314,718.  
FOR TOY VEHICLES (U.S. CLS. 22, 23, 38 AND 50).  
NICHOLAS COLEMAN, EXAMINING ATTORNEY

THE MARK CONSISTS OF STANDARD CHARACTERS WITHOUT CLAIM TO ANY PARTICULAR FONT, STYLE, SIZE, OR COLOR.

OWNER OF U.S. REG. NO. 3,097,958.  
FOR ACTION FIGURES AND ACCESSORIES THEREFOR; ARCADE GAMES; BALLOONS; BALLS FOR GAMES; BATTERY OPERATED ACTION TOYS; BEAN BAG DOLLS; BENDABLE TOYS; BOARD GAMES; BOBBLE HEAD DOLLS; CARD GAMES; CHESS SETS; CHILDREN'S MULTIPLE ACTIVITY TOYS; CHRISTMAS TREE DECORATIONS; COIN-OPERATED VIDEO GAMES; DOLLS AND ACCESSORIES THEREFOR; FLYING DISCS; GAME TABLES; HAND HELD UNITS FOR PLAYING VIDEO GAMES OTHER THAN THOSE ADAPTED FOR USE WITH AN EXTERNAL DISPLAY SCREEN OR MONITOR; INFLATABLE BOP BAGS; INFLATABLE POOLS FOR RECREATIONAL USE; INFLATABLE TOYS; JIGSAW PUZZLES; JUMP ROPES; KITES; MECHANICAL ACTION TOYS; PINBALL GAMES; PINBALL-TYPE GAMES; PLAYING CARDS; PLAYSETS FOR USE WITH TOY ACTION FIGURES AND FOR MAKE BELIEVE PLAY BATTLE OR ADVENTURE ACTIVITIES; PLUSH TOYS; PUPPETS; RADIO CONTROLLED TOY VEHICLES; ROLE PLAYING GAMES; ROLLER SKATES; RUBBER BALLS; SNOW BOARDS; SNOW SLEDS FOR RECREATIONAL USE; SOFT SCULPTURE TOYS; STUFFED TOY ANIMALS; SURF BOARDS; SURF FINS; SWIM BOARDS FOR RECREATIONAL USE; SWIM FINS; TARGET GAMES; TOY ACTION FIGURES AND ACCESSORIES THEREFOR; TOY MASKS; TOY MODEL HOBBYCRAFT KITS; TOY VEHICLES; TOY WATCHES; TOY WEAPONS; WATER SQUIRTING TOYS; YO-YOS (U.S. CLS. 22, 38 AND 50).  
ANDREW LEASER, EXAMINING ATTORNEY

SN 85-211,107. THE KONG COMPANY, GOLDEN, CO. FILED 1-5-2011.



FOR PET TOYS (U.S. CLS. 22, 23, 38 AND 50).  
KATHRYN COWARD, EXAMINING ATTORNEY

**CLASS 28—(Continued).**

SN 85-219,588. EASTER UNLIMITED, INC., NEW YORK, NY.  
FILED 1-18-2011.



NO CLAIM IS MADE TO THE EXCLUSIVE RIGHT TO USE "EGGS", APART FROM THE MARK AS SHOWN.

THE MARK CONSISTS OF A SMILING CARTOON BUNNY WITH GLASSES HOLDING A SIGN WITH THE WORDS "SMART EGGS" IN LOWER-CASE BUBBLE LETTERS. THE STIPPLING IS FOR SHADING PURPOSES ONLY.

FOR TOYS AND NOVELTIES, NAMELY, MOLDED PLASTIC EASTER EGG TOYS AND TOY CONTAINERS, PLASTIC TOY FIGURINES, NOVELTY PLUSH TOYS BEING PLUSH EASTER EGGS AND PLUSH ANIMALS, EGG CATCH TOYS, AND TOY VEHICLES (U.S. CLS. 22, 23, 38 AND 50).

LINDA POWELL, EXAMINING ATTORNEY

SN 85-226,906. ALL THINGS EQUAL, INC., MIAMI BEACH, FL. FILED 1-26-2011.

## The Greatest Day Ever!

THE MARK CONSISTS OF STANDARD CHARACTERS WITHOUT CLAIM TO ANY PARTICULAR FONT, STYLE, SIZE, OR COLOR.

FOR BOARD GAMES; BOARD GAMES FOR CHILDREN (U.S. CLS. 22, 23, 38 AND 50).

BRENDAN REGAN, EXAMINING ATTORNEY

SN 85-229,987. MATTEL, INC., EL SEGUNDO, CA. FILED 1-31-2011.

## SPIRAL SPINOUT

THE MARK CONSISTS OF STANDARD CHARACTERS WITHOUT CLAIM TO ANY PARTICULAR FONT, STYLE, SIZE, OR COLOR.

FOR TOY VEHICLES AND ACCESSORIES THEREFOR; TOY VEHICLE PLAYSETS AND ACCESSORIES THEREFOR (U.S. CLS. 22, 23, 38 AND 50).

LEIGH LOWRY, EXAMINING ATTORNEY

**CLASS 29—MEATS AND PROCESSED FOODS**

SN 77-639,541. B.R.A.T. DIET LLC, SAN LUIS OBISPO, CA.  
FILED 12-24-2008.

## B.R.A.T.

THE MARK CONSISTS OF STANDARD CHARACTERS WITHOUT CLAIM TO ANY PARTICULAR FONT, STYLE, SIZE, OR COLOR.

FOR RICE MILK FOR USE AS A MILK SUBSTITUTE (U.S. CL. 46).

FIRST USE 6-24-2009; IN COMMERCE 6-24-2009.

ANGELA DUONG, EXAMINING ATTORNEY

SN 77-672,488. AHOLD LICENSING SARL, GENEVA, SWITZERLAND, FILED 2-18-2009.

## GUARANTEED VALUE

THE MARK CONSISTS OF STANDARD CHARACTERS WITHOUT CLAIM TO ANY PARTICULAR FONT, STYLE, SIZE, OR COLOR.

OWNER OF U.S. REG. NOS. 1,672,312, 3,147,919 AND OTHERS.

SEC. 2(F).

FOR BACON; CHICKEN; CHILI; FISH; LUNCHEON MEATS (U.S. CL. 46).

FIRST USE 3-18-2007; IN COMMERCE 3-18-2007.

TRACY WHITTAKER-BROWN, EXAMINING ATTORNEY

SN 77-852,935. PURE GOURMET, LLC, GLENSIDE, PA.  
FILED 10-20-2009.



NO CLAIM IS MADE TO THE EXCLUSIVE RIGHT TO USE "GOURMET", APART FROM THE MARK AS SHOWN.

THE MARK CONSISTS OF THE STYLIZED WORD "PURE" IN CAPITAL LETTERS OVER THE STYLIZED WORD "GOURMET" IN SMALL LETTERS IN A BOWL-SHAPED BACKGROUND.

FOR FROZEN PREPARED MEALS CONSISTING PRIMARILY OF MEAT, FISH, POULTRY OR VEGETABLES; AND FROZEN APPETIZERS CONSISTING PRIMARILY OF MEAT, FISH, POULTRY OR VEGETABLES (U.S. CL. 46).

KIM SAITO, EXAMINING ATTORNEY



**CLASS 29—(Continued).**

SN 77-896,135. DAIRY FARMERS LIMITED, VICTORIA, AUSTRALIA, FILED 12-17-2009.

**MIL LEL**

THE MARK CONSISTS OF STANDARD CHARACTERS WITHOUT CLAIM TO ANY PARTICULAR FONT, STYLE, SIZE, OR COLOR.

THE WORDING "MIL LEL" HAS NO MEANING IN A FOREIGN LANGUAGE.

FOR DAIRY PRODUCTS, EXCLUDING ICE CREAM, ICE MILK AND FROZEN YOGURT; MILK; MILK PRODUCTS, EXCLUDING ICE CREAM, ICE MILK AND FROZEN YOGURT; FLAVORED MILK BEVERAGES CONTAINING CHOCOLATE AND COFFEE; ULTRA-HIGH TEMPERATURE (UHT) PROCESSED MILK; CHEESES; YOGURTS; BUTTERS AND CREAMS; DAIRY-BASED DESSERTS, NAMELY, FRESH UNRIPE CHEESES (U.S. CL. 46).

DEZMONA MIZELLE, EXAMINING ATTORNEY

SN 77-969,748. CHANG SHING TOFU, INC., CAMBRIDGE, MA. FILED 3-26-2010.

長興豆品公司

NO CLAIM IS MADE TO THE EXCLUSIVE RIGHT TO USE THE NON-LATIN CHARACTERS THAT TRANSLITERATE TO "DAO BUN GONG SI", APART FROM THE MARK AS SHOWN.

THE MARK CONSISTS OF SIX CHINESE CHARACTERS. THE ENGLISH TRANSLATION OF THE SIX CHINESE CHARACTERS IN THE MARK IS "LONG PROSPERITY TOFU COMPANY."

THE NON-LATIN CHARACTERS IN THE MARK TRANSLITERATE TO "CHEUNG HING DAO BUN GONG SI" AND THIS MEANS "LONG PROSPERITY TOFU COMPANY" IN ENGLISH.

FOR TOFU (U.S. CL. 46).

FIRST USE 2-1-1991; IN COMMERCE 2-1-1991.

HOWARD B. LEVINE, EXAMINING ATTORNEY

SN 79-091,837. COÖPERATIEVE ZUIVELONDERNEMING CONO B.A., NETHERLANDS, FILED 11-15-2010.

**GENERATIONS OF GREAT TASTE**

THE MARK CONSISTS OF STANDARD CHARACTERS WITHOUT CLAIM TO ANY PARTICULAR FONT, STYLE, SIZE, OR COLOR.

PRIORITY DATE OF 7-28-2010 IS CLAIMED.

OWNER OF INTERNATIONAL REGISTRATION 1063146 DATED 11-15-2010, EXPIRES 11-15-2020.

FOR CHEESE (U.S. CL. 46).

DAVID TOOLEY, EXAMINING ATTORNEY

**CLASS 29—(Continued).**

SN 85-005,989. BEEPCO, INC., DBA COUNTRY MEATS, OCALA, FL. FILED 4-5-2010.

**GASPARILLA GOLD**

THE MARK CONSISTS OF STANDARD CHARACTERS WITHOUT CLAIM TO ANY PARTICULAR FONT, STYLE, SIZE, OR COLOR.

FOR MEAT-BASED SNACK FOODS (U.S. CL. 46).

MARILYN IZZI, EXAMINING ATTORNEY

SN 85-006,579. RUN BRANDS, L.L.C., SPRINGFIELD, MO. FILED 4-5-2010.

**TABLE-TIZERS**

THE MARK CONSISTS OF STANDARD CHARACTERS WITHOUT CLAIM TO ANY PARTICULAR FONT, STYLE, SIZE, OR COLOR.

FOR DIPS, HUMMOS, CANDIED JALAPENOS (U.S. CL. 46).

ANDREA HACK, EXAMINING ATTORNEY

SN 85-009,066. SAN MIGUEL PUREFOODS COMPANY, INC., METRO MANILA, PHILIPPINES, FILED 4-8-2010.



NO CLAIM IS MADE TO THE EXCLUSIVE RIGHT TO USE "PUREFOODS", "TENDER", "JUICY", "HOTDOG", "ORIGINAL" AND "ARTIFICIALLY COLORED", APART FROM THE MARK AS SHOWN.

THE COLOR(S) RED, BLUE, YELLOW AND WHITE IS/ARE CLAIMED AS A FEATURE OF THE MARK.

THE MARK CONSISTS OF THE STYLIZED PHRASE "SAN MIGUEL" WHEREIN THE DOT OVER THE LETTER "I" IS REPRESENTED BY TWO STYLIZED LEAVES, ABOVE THE STYLIZED PHRASE "PURE FOODS" ENCLOSED WITHIN TWO ROUNDED CORNER RECTANGLES ABOVE THE TERM "TENDER", ABOVE THE TERM "JUICY" ABOVE THE TERM "HOTDOG" ALL OF WHICH ARE DISPLAYED ON A SLIGHT DIAGONAL AND SUPERIMPOSED ON A SERIES OF CONCENTRIC OVALS, ABOVE THE TERM "ORIGINAL", WHICH APPEARS BELOW AND ON THE RIGHT OF THE CONCENTRIC OVALS WITH THE

**CLASS 29—(Continued).**

PHRASE "ARTIFICIALLY COLORED" BELOW AND ON THE LEFT OF THE CONCENTRIC OVALS; THE COLOR RED APPEARS IN THE BACKGROUND OF THE MARK IN THE TERM "PURE", IN THE BOTTOM OF THE LEFT ROUNDED CORNER RECTANGLE, IN THE TOP OF THE RIGHT ROUNDED CORNER RECTANGLE IN THE MIDDLE CONCENTRIC OVAL AND IN THE TERM "HOTDOG"; THE COLOR BLUE APPEARS IN THE UPPER LEFT ROUNDED CORNER RECTANGLE, THE LOWER RIGHT ROUNDED CORNER RECTANGLE AND IN THE TERMS "FOODS", "TENDER" AND "JUICY"; THE COLOR YELLOW APPEARS IN THE BACKGROUND OF THE CONCENTRIC OVALS; THE COLOR WHITE APPEARS IN THE SHADING AROUND THE PHRASE "SAN MIGUEL" AND THE STYLIZED LEAVES, IN THE BACKGROUND AND THE SHADING AROUND THE ROUNDED CORNER RECTANGLES, IN THE OUTERMOST CONCENTRIC OVAL, IN THE SHADING AROUND THE TERMS "TENDER", "JUICY" AND "HOTDOG", IN THE TERM "ORIGINAL" AND IN THE PHRASE "ARTIFICIALLY COLORED".

FOR HOTDOG (U.S. CL. 46).

MYRIAH HABEEB, EXAMINING ATTORNEY

SN 85-017,986. SEOUL DAIRY CO-OP, SEOUL, REPUBLIC OF KOREA, FILED 4-20-2010.



NO CLAIM IS MADE TO THE EXCLUSIVE RIGHT TO USE THE NON-LATIN CHARACTERS THAT TRANSLITERATE TO SEOUL WOYU AND "SEOUL MILK", APART FROM THE MARK AS SHOWN.

THE COLOR(S) RED IS/ARE CLAIMED AS A FEATURE OF THE MARK.

THE MARK CONSISTS OF THE STYLIZED WORDS "SEOUL MILK" IN RED COLOR APPEARING ON THE RIGHT SIDE OF A RED CIRCLE. WITHIN THE RED CIRCLE ARE FOUR KOREAN CHARACTERS. FURTHER, OVER THE FOUR KOREAN CHARACTERS AND WITHIN THE RED CIRCLE IS A SMALL YIN YANG IMAGE APPEARING PARTLY IN RED. THE COLOR WHITE IS NOT CLAIMED AS A FEATURE OF THE MARK AND REPRESENTS BACKGROUND.

THE NON-LATIN CHARACTERS IN THE MARK TRANSLITERATE TO SEOUL WOYU AND THIS MEANS "SEOUL MILK" IN ENGLISH.

FOR MILK (U.S. CL. 46).

FIRST USE 6-0-1998; IN COMMERCE 10-0-2005.

KHANH LE, EXAMINING ATTORNEY

**CLASS 29—(Continued).**

SN 85-048,423. WILDCRAFT FARMS INC., SWAN LAKE, NY. FILED 5-26-2010.



NO CLAIM IS MADE TO THE EXCLUSIVE RIGHT TO USE "FARMS" AND "EST.2003", APART FROM THE MARK AS SHOWN.

THE MARK CONSISTS OF A BEEF STEER WITH A ROOSTER STANDING ON THE STEER'S BACK FACING THE SAME DIRECTION. BELOW THE STEER IS THE WORDING "WILDCRAFT FARMS" WITH "EST. 2003" BETWEEN THE TWO TERMS.

FOR BEEF, POULTRY, LAMB, PORK, EGGS (U.S. CL. 46).

FIRST USE 3-1-2003; IN COMMERCE 3-1-2003.

KATINA MISTER, EXAMINING ATTORNEY

SN 85-064,219. FLUITT, MICHAEL C., DBA MICKLE'S PICKLES, PICAYUNE, MS. FILED 6-16-2010.

## Mickle's Pickles

THE MARK CONSISTS OF STANDARD CHARACTERS WITHOUT CLAIM TO ANY PARTICULAR FONT, STYLE, SIZE, OR COLOR.

NO CLAIM IS MADE TO THE EXCLUSIVE RIGHT TO USE "PICKLES", APART FROM THE MARK AS SHOWN.

SEC. 2(F).

FOR PICKLES (U.S. CL. 46).

FIRST USE 11-21-1999; IN COMMERCE 11-21-1999.

SETH A. RAPPAPORT, EXAMINING ATTORNEY

**CLASS 29—(Continued).**

SN 85-068,169. ZENNIX LIFEFOODS, LLC, DBA HARVEST ROAST, WARREN, OR. FILED 6-21-2010.

## Harvest Roast

THE MARK CONSISTS OF STANDARD CHARACTERS WITHOUT CLAIM TO ANY PARTICULAR FONT, STYLE, SIZE, OR COLOR.

NO CLAIM IS MADE TO THE EXCLUSIVE RIGHT TO USE "ROAST", APART FROM THE MARK AS SHOWN.

FOR (BASED ON USE IN COMMERCE) PROCESSED EDIBLE SEEDS; PROCESSED PUMPKIN SEEDS; (BASED ON INTENT TO USE) ORGANIC NUT AND SEED-BASED SNACK BARS; SNACK MIX CONSISTING OF PRIMARILY OF PROCESSED NUTS, SEEDS, DRIED FRUIT AND ALSO INCLUDING CHOCOLATE; SNACK MIX CONSISTING PRIMARILY OF PROCESSED NUTS AND SALTED SQUASH SEEDS AND ALSO INCLUDING TOASTED CORN (U.S. CL. 46).

FIRST USE 6-1-2002; IN COMMERCE 9-1-2002.  
YAT SYE, LEE, EXAMINING ATTORNEY

SN 85-090,575. BAM'S JERKY, INC., BROOKLYN, NY. FILED 7-22-2010.



NO CLAIM IS MADE TO THE EXCLUSIVE RIGHT TO USE "JERKY" AND "BROOKLYN, NY", APART FROM THE MARK AS SHOWN.

THE NAME(S), PORTRAIT(S), AND/OR SIGNATURE(S) SHOWN IN THE MARK IDENTIFIES EDUARDO M. ROMERO, WHOSE CONSENT(S) TO REGISTER IS MADE OF RECORD.

THE MARK CONSISTS OF THE WORDS "MADE WITH LOVE IN BROOKLYN, NY" AROUND THE TOP OF A CIRCLE, WITH ONE SMALL HEART IN FRONT OF THE WORD "MADE" AND ANOTHER SMALL HEART AFTER THE TERM "NY"; THE BACKGROUND OF THE CIRCLE CONTAINS SMALL POLKA DOTS; THE LOWER HALF OF THE CIRCLE IS CROSSED BY A BANNER WITH THE WORD "BAM'S" USING A STAR FOR THE APOSTROPHE; FROM BELOW AND BEHIND THE BANNER IS THE LOWER HALF OF A SHIELD WITH THE WORD "JERKY"; WITHIN THE CIRCLE FROM BEHIND AND ABOVE THE BANNER IS AN IMAGE OF THE TOP PART OF A SMILING MAN WITH SHOULDER LENGTH HAIR WEARING A T-SHIRT; THE MAN'S RIGHT ARM IN THE LEFT HALF OF THE CIRCLE IS BACK WITH ONE THUMB UP; THE MAN'S LEFT ARM IN THE RIGHT HALF OF CIRCLE IS FORWARD AND IN FRONT OF THE BANNER HOLDING ONE PIECE OF BEEF JERKY; BEHIND THE BEEF JERKY IS A SHADED SOLID AREA WITH JAGGED ZIGZAG EDGES.

FOR JERKY (U.S. CL. 46).  
FIRST USE 9-27-2008; IN COMMERCE 9-27-2008.  
TIMOTHY FINNEGAN, EXAMINING ATTORNEY

**CLASS 29—(Continued).**

SN 85-090,896. HIP TO BE CRISP, LLC, PORTLAND, OR. FILED 7-22-2010.



THE MARK CONSISTS OF A STYLIZED DESIGN OF A SUN OVER THE STYLIZED WORDING "HIP TO BE CRISP".

FOR BAKED AND DEHYDRATED SNACK PRODUCTS, NAMELY, VEGETABLES AND FRUITS, PROCESSED VEGETABLE AND FRUIT MIXES, COMBINATION VEGETABLE SALADS AND SOUP MIXES, GARLIC BASED SNACKS, GARLIC FLAVORED SNACKS, NAMELY, GARLIC FLAVORED POTATO CHIPS AND VEGETABLE CHIPS, PROCESSED EDIBLE SEEDS AND NUTS, DRIED FRUIT, AND VEGETABLE CHIPS (U.S. CL. 46).

JEFFERY COWARD, EXAMINING ATTORNEY

SN 85-124,447. MARK'S MART, LLC, SELMA, AL. FILED 9-7-2010.

## CHICKEN SWIRL

THE MARK CONSISTS OF STANDARD CHARACTERS WITHOUT CLAIM TO ANY PARTICULAR FONT, STYLE, SIZE, OR COLOR.

NO CLAIM IS MADE TO THE EXCLUSIVE RIGHT TO USE "CHICKEN", APART FROM THE MARK AS SHOWN. FOR PACKAGED CHICKEN (U.S. CL. 46).

FIRST USE 12-31-1993; IN COMMERCE 1-25-1999.  
ELIZABETH HUGHITT, EXAMINING ATTORNEY

SN 85-128,190. PEELED INC., BROOKLYN, NY. FILED 9-13-2010.



OWNER OF U.S. REG. NO. 3,040,926.

NO CLAIM IS MADE TO THE EXCLUSIVE RIGHT TO USE "ORGANIC", APART FROM THE MARK AS SHOWN.

THE MARK CONSISTS OF THE WORD "PEELED" WITH A SINGLE LEAF ON EITHER SIDE OF THE STEM OF THE LETTER "D" AND THE WORD "ORANGIC" BENEATH IT. SEC. 2(F) AS TO "PEELED".

FOR DRIED ORGANIC FRUITS (U.S. CL. 46).  
FIRST USE 9-30-2010; IN COMMERCE 9-30-2010.  
SHAUNIA CARLYLE, EXAMINING ATTORNEY

**CLASS 29—(Continued).**

SN 85-137,443. MISH FARMS MEAT MARKET, INC., GIBSONIA, PA. FILED 9-24-2010.

FREE TO CHEWS ALL NATURAL  
BEEF

THE MARK CONSISTS OF STANDARD CHARACTERS WITHOUT CLAIM TO ANY PARTICULAR FONT, STYLE, SIZE, OR COLOR.

FOR PREPARED NATURAL BEEF; NAMELY, GROUND BEEF, BEEF PATTIES, STEAKS, ROASTS AND BEEF SNACK STICKS (U.S. CL. 46).

DAVID C. REIHNER, EXAMINING ATTORNEY

SN 85-139,285. SEA LION INTERNATIONAL, INC, MARGATE, FL. FILED 9-27-2010.

SCEPTER

THE MARK CONSISTS OF STANDARD CHARACTERS WITHOUT CLAIM TO ANY PARTICULAR FONT, STYLE, SIZE, OR COLOR.

FOR SEAFOOD; SHELLFISH; SHRIMP; SHRIMPS, NOT LIVE; SHRIMPS, PRAWNS AND LOBSTERS (U.S. CL. 46).

FIRST USE 1-1-2005; IN COMMERCE 1-1-2005.

SAMUEL E. SHARPER JR., EXAMINING ATTORNEY

SN 85-142,180. GERBER POULTRY, INC., KIDRON, OH. FILED 9-30-2010.

GERBER'S AMISH FARM CHICKEN

THE MARK CONSISTS OF STANDARD CHARACTERS WITHOUT CLAIM TO ANY PARTICULAR FONT, STYLE, SIZE, OR COLOR.

OWNER OF U.S. REG. NOS. 3,079,015 AND 3,161,617.

NO CLAIM IS MADE TO THE EXCLUSIVE RIGHT TO USE "AMISH FARM CHICKEN", APART FROM THE MARK AS SHOWN.

FOR POULTRY PRODUCTS, NAMELY, CHICKEN (U.S. CL. 46).

FIRST USE 8-1-2010; IN COMMERCE 8-1-2010.

KAREN K. BUSH, EXAMINING ATTORNEY

**CLASS 29—(Continued).**

SN 85-142,288. BEECH-NUT NUTRITION CORPORATION, AMSTERDAM, NY. FILED 9-30-2010.

HERO FRUIT SPREADABLES

THE MARK CONSISTS OF STANDARD CHARACTERS WITHOUT CLAIM TO ANY PARTICULAR FONT, STYLE, SIZE, OR COLOR.

NO CLAIM IS MADE TO THE EXCLUSIVE RIGHT TO USE "FRUIT SPREADABLES", APART FROM THE MARK AS SHOWN.

FOR FRUIT BASED SPREADS (U.S. CL. 46).

SUNG IN, EXAMINING ATTORNEY

SN 85-144,954. BEECH-NUT NUTRITION CORPORATION, AMSTERDAM, NY. FILED 10-5-2010.

HERO SPREADABLES

THE MARK CONSISTS OF STANDARD CHARACTERS WITHOUT CLAIM TO ANY PARTICULAR FONT, STYLE, SIZE, OR COLOR.

NO CLAIM IS MADE TO THE EXCLUSIVE RIGHT TO USE "SPREADABLES", APART FROM THE MARK AS SHOWN.

FOR FRUIT-BASED SPREADS (U.S. CL. 46).

SUNG IN, EXAMINING ATTORNEY

SN 85-149,746. RHINO FOODS, INC., BURLINGTON, VT. FILED 10-11-2010.

TRUE ESSENCE FRUIT

THE MARK CONSISTS OF STANDARD CHARACTERS WITHOUT CLAIM TO ANY PARTICULAR FONT, STYLE, SIZE, OR COLOR.

NO CLAIM IS MADE TO THE EXCLUSIVE RIGHT TO USE "FRUIT", APART FROM THE MARK AS SHOWN.

FOR FRUIT CONCENTRATES AND PUREES USED AS AN INGREDIENT IN ICE CREAM AND FROZEN DESSERTS (U.S. CL. 46).

MARIA-VICTORIA SUAREZ, EXAMINING ATTORNEY

**CLASS 29—(Continued).**

SN 85-152,132. FIRESTONE PACIFIC FOODS, INC., VANCOUVER, WA. FILED 10-13-2010.

**FIRESTONE HERITAGE FARMS**

THE MARK CONSISTS OF STANDARD CHARACTERS WITHOUT CLAIM TO ANY PARTICULAR FONT, STYLE, SIZE, OR COLOR.

NO CLAIM IS MADE TO THE EXCLUSIVE RIGHT TO USE "FARMS", APART FROM THE MARK AS SHOWN.

FOR DRIED FRUITS; FROZEN FRUITS (U.S. CL. 46).  
MARGERY A. TIERNEY, EXAMINING ATTORNEY

SN 85-153,496. OMAHA STEAKS INTERNATIONAL, INC., OMAHA, NE. FILED 10-15-2010.

**OMAHA FRESH BY OMAHA STEAKS**

THE MARK CONSISTS OF STANDARD CHARACTERS WITHOUT CLAIM TO ANY PARTICULAR FONT, STYLE, SIZE, OR COLOR.

OWNER OF U.S. REG. NOS. 2,002,499, 3,774,260 AND OTHERS.

NO CLAIM IS MADE TO THE EXCLUSIVE RIGHT TO USE "FRESH" AND "STEAKS", APART FROM THE MARK AS SHOWN.

SEC. 2(F) AS TO "OMAHA".  
FOR MEAT (U.S. CL. 46).  
DANIEL CAPSHAW, EXAMINING ATTORNEY

SN 85-155,374. PHILLIPS FOODS, INC., BALTIMORE, MD. FILED 10-18-2010.

**EVERYDAY CRAB CAKE**

THE MARK CONSISTS OF STANDARD CHARACTERS WITHOUT CLAIM TO ANY PARTICULAR FONT, STYLE, SIZE, OR COLOR.

NO CLAIM IS MADE TO THE EXCLUSIVE RIGHT TO USE "CRAB CAKE", APART FROM THE MARK AS SHOWN.

FOR CRAB CAKES (U.S. CL. 46).  
FIRST USE 8-20-2010; IN COMMERCE 8-20-2010.  
ROSELLE HERRERA, EXAMINING ATTORNEY

**CLASS 29—(Continued).**

SN 85-156,607. PACIFIC PICKLE WORKS, INC., SANTA BARBARA, CA. FILED 10-20-2010.

**PACIFIC PICKLE WORKS**

THE MARK CONSISTS OF STANDARD CHARACTERS WITHOUT CLAIM TO ANY PARTICULAR FONT, STYLE, SIZE, OR COLOR.

NO CLAIM IS MADE TO THE EXCLUSIVE RIGHT TO USE "PICKLE WORKS", APART FROM THE MARK AS SHOWN.

FOR PICKLED CUCUMBERS; PICKLED VEGETABLES (U.S. CL. 46).

FIRST USE 7-2-2010; IN COMMERCE 9-1-2010.  
KAREN K. BUSH, EXAMINING ATTORNEY

SN 85-157,572. PRIME TIME BUTCHER, INC., WOODBURY, NY. FILED 10-20-2010.

**Bliss Burgers**

THE MARK CONSISTS OF STANDARD CHARACTERS WITHOUT CLAIM TO ANY PARTICULAR FONT, STYLE, SIZE, OR COLOR.

NO CLAIM IS MADE TO THE EXCLUSIVE RIGHT TO USE "BURGERS", APART FROM THE MARK AS SHOWN.

FOR UNCOOKED HAMBURGER PATTIES (U.S. CL. 46).

FIRST USE 6-1-2009; IN COMMERCE 6-1-2009.  
KRISTIN DAHLING, EXAMINING ATTORNEY

SN 85-158,088. WALLIEN, JAMESON D, ZIONSVILLE, IN. FILED 10-21-2010.

**Big Dipper Peanut Butter**

THE MARK CONSISTS OF STANDARD CHARACTERS WITHOUT CLAIM TO ANY PARTICULAR FONT, STYLE, SIZE, OR COLOR.

NO CLAIM IS MADE TO THE EXCLUSIVE RIGHT TO USE "PEANUT BUTTER", APART FROM THE MARK AS SHOWN.

FOR PEANUT BUTTER (U.S. CL. 46).  
FIRST USE 4-18-2010; IN COMMERCE 4-18-2010.  
ALYSSA STEEL, EXAMINING ATTORNEY

**CLASS 29—(Continued).**

SN 85-158,153. JERKCO II LLC, OWINGS MILLS, MD. FILED 10-21-2010.

¡Ay Caramba!

THE MARK CONSISTS OF STANDARD CHARACTERS WITHOUT CLAIM TO ANY PARTICULAR FONT, STYLE, SIZE, OR COLOR.

THE ENGLISH TRANSLATION OF "AY CARAMBA" IS "HOLY COW" OR "OH MY GOODNESS".

FOR BEEF JERKY; JERKY (U.S. CL. 46).

FIRST USE 11-1-2010; IN COMMERCE 11-1-2010.

DORITT L. CARROLL, EXAMINING ATTORNEY

SN 85-168,580. OZARK MOUNTAIN HOLDINGS, LLC, FAYETTEVILLE, AR. FILED 11-3-2010.

OZARK MOUNTAIN SMOKEHOUSE

THE MARK CONSISTS OF STANDARD CHARACTERS WITHOUT CLAIM TO ANY PARTICULAR FONT, STYLE, SIZE, OR COLOR.

OWNER OF U.S. REG. NOS. 905,205 AND 2,745,800.

NO CLAIM IS MADE TO THE EXCLUSIVE RIGHT TO USE "SMOKEHOUSE", APART FROM THE MARK AS SHOWN.

SEC. 2(F).

FOR CHEESE; FOOD PACKAGE COMBINATIONS CONSISTING PRIMARILY OF CHEESE, MEAT AND/OR PROCESSED FRUIT; FRUIT JELLIES; FRUIT PRESERVES; FRUIT PUREES; GAME; JELLIES AND JAMS; LUNCHEON MEATS; MEAT; MEAT, FISH, POULTRY AND GAME; MEAT, FRUIT AND VEGETABLE JELLIES, JAMS, EGGS; PACKAGED MEATS; PREPARED FOOD KITS COMPOSED OF MEAT, POULTRY, FISH, SEAFOOD, AND/OR VEGETABLES AND ALSO INCLUDING SAUCES OR SEASONINGS, READY FOR COOKING AND ASSEMBLY AS A MEAL; PREPARED MEAT; PROCESSED MEAT; SMOKED FISH (U.S. CL. 46).

FIRST USE 12-31-1946; IN COMMERCE 12-31-1946.

STEVEN JACKSON, EXAMINING ATTORNEY

**CLASS 29—(Continued).**

SN 85-168,599. OZARK MOUNTAIN HOLDINGS, LLC, FAYETTEVILLE, AR. FILED 11-3-2010.

OZARK MOUNTAIN

THE MARK CONSISTS OF STANDARD CHARACTERS WITHOUT CLAIM TO ANY PARTICULAR FONT, STYLE, SIZE, OR COLOR.

OWNER OF U.S. REG. NOS. 905,205 AND 2,745,800.

SEC. 2(F).

FOR CHEESE; FOOD PACKAGE COMBINATIONS CONSISTING PRIMARILY OF CHEESE, MEAT AND/OR PROCESSED FRUIT; FRUIT JELLIES; FRUIT PRESERVES; FRUIT PUREES; GAME; JELLIES AND JAMS; LUNCHEON MEATS; MEAT; MEAT, FISH, POULTRY AND GAME; MEAT, FRUIT AND VEGETABLE JELLIES, JAMS, EGGS; PACKAGED MEATS; PREPARED FOOD KITS COMPOSED OF MEAT, POULTRY, FISH, SEAFOOD, AND/OR VEGETABLES AND ALSO INCLUDING SAUCES OR SEASONINGS, READY FOR COOKING AND ASSEMBLY AS A MEAL; PREPARED MEAT; PROCESSED MEAT; SMOKED FISH (U.S. CL. 46).

FIRST USE 12-31-1946; IN COMMERCE 12-31-1946.

STEVEN JACKSON, EXAMINING ATTORNEY

SN 85-168,696. OZARK MOUNTAIN HOLDINGS, LLC, FAYETTEVILLE, AR. FILED 11-3-2010.

OZARK MOUNTAIN FAMILY

THE MARK CONSISTS OF STANDARD CHARACTERS WITHOUT CLAIM TO ANY PARTICULAR FONT, STYLE, SIZE, OR COLOR.

OWNER OF U.S. REG. NOS. 905,205 AND 2,745,800.

SEC. 2(F).

FOR CHEESE; FOOD PACKAGE COMBINATIONS CONSISTING PRIMARILY OF CHEESE, MEAT AND/OR PROCESSED FRUIT; FRUIT JELLIES; FRUIT PRESERVES; FRUIT PUREES; GAME; JELLIES AND JAMS; LUNCHEON MEATS; MEAT; MEAT, FISH, POULTRY AND GAME; MEAT, FRUIT AND VEGETABLE JELLIES, JAMS, EGGS; PACKAGED MEATS; PREPARED FOOD KITS COMPOSED OF MEAT, POULTRY, FISH, SEAFOOD, AND/OR VEGETABLES AND ALSO INCLUDING SAUCES OR SEASONINGS, READY FOR COOKING AND ASSEMBLY AS A MEAL; PREPARED MEAT; PROCESSED MEAT; SMOKED FISH (U.S. CL. 46).

FIRST USE 12-31-1946; IN COMMERCE 12-31-1946.

STEVEN JACKSON, EXAMINING ATTORNEY

**CLASS 29—(Continued).**

SN 85-169,245. MARJORIE J. SUSMAN, NEW HAVEN, VT. AND MARIAN POLLACK, NEW HAVEN, VT. FILED 11-4-2010.

**ORB WEAVER FARM**

THE MARK CONSISTS OF STANDARD CHARACTERS WITHOUT CLAIM TO ANY PARTICULAR FONT, STYLE, SIZE, OR COLOR.

NO CLAIM IS MADE TO THE EXCLUSIVE RIGHT TO USE "FARM", APART FROM THE MARK AS SHOWN.

FOR CHEESE (U.S. CL. 46).  
FIRST USE 3-0-1981; IN COMMERCE 3-0-1981.  
EDWARD NELSON, EXAMINING ATTORNEY

SN 85-174,304. BAD ASS ORGANICS, LLC, JERSEY CITY, NJ. FILED 11-11-2010.

**BAO**

THE MARK CONSISTS OF STANDARD CHARACTERS WITHOUT CLAIM TO ANY PARTICULAR FONT, STYLE, SIZE, OR COLOR.

OWNER OF U.S. REG. NO. 3,832,870.  
THE WORDING BAO HAS NO MEANING IN A FOREIGN LANGUAGE.

FOR FRESH, PREPARED AND PACKAGED MEALS CONSISTING PRIMARILY OF MEAT, FISH, POULTRY OR VEGETABLES (U.S. CL. 46).

ANN E. SAPPENFIELD, EXAMINING ATTORNEY

SN 85-175,833. EARTH2MAN, LLC, LAPORTE, CO. FILED 11-12-2010.

**E2M=C**

THE MARK CONSISTS OF STANDARD CHARACTERS WITHOUT CLAIM TO ANY PARTICULAR FONT, STYLE, SIZE, OR COLOR.

FOR FRUIT-BASED SNACK FOOD (U.S. CL. 46).  
CHRIS WELLS, EXAMINING ATTORNEY

**CLASS 29—(Continued).**

SN 85-175,942. NATIONAL DAIRY, LLC, DALLAS, TX. FILED 11-12-2010.

**YOMILK**

THE MARK CONSISTS OF STANDARD CHARACTERS WITHOUT CLAIM TO ANY PARTICULAR FONT, STYLE, SIZE, OR COLOR.

FOR DAIRY PRODUCTS EXCLUDING ICE CREAM, ICE MILK AND FROZEN YOGURT (U.S. CL. 46).

MICHELE SWAIN, EXAMINING ATTORNEY

SN 85-176,710. DAZY'S LLC, BOULDER, CO. FILED 11-15-2010.

**HIGHRISH CREAM**

THE MARK CONSISTS OF STANDARD CHARACTERS WITHOUT CLAIM TO ANY PARTICULAR FONT, STYLE, SIZE, OR COLOR.

NO CLAIM IS MADE TO THE EXCLUSIVE RIGHT TO USE "CREAM", APART FROM THE MARK AS SHOWN.

FOR CREAMERS FOR BEVERAGES (U.S. CL. 46).

FIRST USE 9-1-2010; IN COMMERCE 9-1-2010.  
C. DIONNE CLYBURN, EXAMINING ATTORNEY

SN 85-178,240. KINETIX LIVING CORP., SEATTLE, WA. FILED 11-16-2010.



THE MARK CONSISTS OF A STYLIZED DESIGN OF THE CAPITAL LETTER "K" FOLLOWED BY A LOWER CASE "X" ALL WITHIN A SQUARE SHAPED DESIGN.

FOR PACKAGED MEALS CONSISTING PRIMARILY OF MEAT, POULTRY, FISH, OR VEGETABLES; DAIRY BASED BEVERAGES; DAIRY BASED FOOD BEVERAGES; SOUPS, SOUP MIXES; SOY BASED SNACK FOODS; PROTEIN BASED SNACK BARS (U.S. CL. 46).

GIANCARLO CASTRO, EXAMINING ATTORNEY

**CLASS 29—(Continued).**

SN 85-178,254. KINETIX LIVING CORP., SEATTLE, WA.  
FILED 11-16-2010.

Rebel. Ignite. Commit.

THE MARK CONSISTS OF STANDARD CHARACTERS WITHOUT CLAIM TO ANY PARTICULAR FONT, STYLE, SIZE, OR COLOR.

FOR PACKAGED MEALS CONSISTING PRIMARILY OF MEAT, POULTRY, FISH, OR VEGETABLES; DAIRY BASED BEVERAGES; DAIRY BASED FOOD BEVERAGES; SOUPS, SOUP MIXES; SOY BASED SNACK FOODS; PROTEIN BASED SNACK BARS (U.S. CL. 46).  
SANI KHOURI, EXAMINING ATTORNEY

SN 85-178,855. SIMPLY SOUTHERN SIDES, LLC, NORTH-FIELD, OH. FILED 11-17-2010.

Simply Prepared...Simply  
Delicious!

THE MARK CONSISTS OF STANDARD CHARACTERS WITHOUT CLAIM TO ANY PARTICULAR FONT, STYLE, SIZE, OR COLOR.

FOR PRE-PACKAGED DINNERS CONSISTING OF PRIMARILY VEGETABLES; PROCESSED BEANS; PROCESSED SWEET POTATOES; PROCESSED VEGETABLES; VEGETABLES, NAMELY, FROZEN COLLARD GREENS, TURNIP GREENS, GREEN BEANS, BLACK-EYE PEAS, LIMA BEANS, PINTO BEANS, OKRA AND TOMATO, CORN, RED BEANS, AND BLACK BEANS (U.S. CL. 46).

FIRST USE 11-11-2010; IN COMMERCE 11-11-2010.  
CHERYL CLAYTON, EXAMINING ATTORNEY

SN 85-179,083. FOX FIRE FARMS L.L.C. THREE, DBA FOX FIRE FARMS, IGNACIO, CO. FILED 11-17-2010.

FOX FIRE

THE MARK CONSISTS OF STANDARD CHARACTERS WITHOUT CLAIM TO ANY PARTICULAR FONT, STYLE, SIZE, OR COLOR.

OWNER OF U.S. REG. NOS. 2,969,837 AND 3,855,906.  
FOR MEAT (U.S. CL. 46).  
FIRST USE 1-31-2000; IN COMMERCE 1-31-2000.  
BARBARA GAYNOR, EXAMINING ATTORNEY

**CLASS 29—(Continued).**

SN 85-180,526. GLOBAL NUTRITION AND HEALTH PARTNERS, INC., LEMON GROVE, CA. FILED 11-18-2010.

MoringaVita

THE MARK CONSISTS OF STANDARD CHARACTERS WITHOUT CLAIM TO ANY PARTICULAR FONT, STYLE, SIZE, OR COLOR.

FOR READY-TO-EAT NUT-BASED FOOD SNACK ALSO CONTAINING MORINGA (U.S. CL. 46).  
IRA J. GOODSaid, EXAMINING ATTORNEY

SN 85-182,563. YOPLAIT MARQUES INTERNATIONALES, PARIS, FRANCE, FILED 11-22-2010.

YOPLAIT PARFAITPRO

THE MARK CONSISTS OF STANDARD CHARACTERS WITHOUT CLAIM TO ANY PARTICULAR FONT, STYLE, SIZE, OR COLOR.

OWNER OF U.S. REG. NOS. 930,605, 3,539,809 AND OTHERS.

FOR DAIRY PRODUCTS, EXCLUDING ICE CREAM, ICE MILK AND FROZEN YOGURT (U.S. CL. 46).  
FIRST USE 7-13-2009; IN COMMERCE 7-13-2009.  
RICHARD WHITE, EXAMINING ATTORNEY

SN 85-189,752. SARTORI COMPANY, PLYMOUTH, WI. FILED 12-2-2010.

PAOLO SARTORI

THE MARK CONSISTS OF STANDARD CHARACTERS WITHOUT CLAIM TO ANY PARTICULAR FONT, STYLE, SIZE, OR COLOR.

OWNER OF U.S. REG. NOS. 2,653,233, 3,321,848 AND 3,565,483.

THE TERM "PAOLO SARTORI" DOES NOT IDENTIFY A LIVING INDIVIDUAL.

FOR CHEESE (U.S. CL. 46).  
RUDY R. SINGLETON, EXAMINING ATTORNEY



**CLASS 29—(Continued).**

SN 85-195,360. PAN AMERICAN GRAIN MFG. CO., INC., GUAYNABO, PUERTO RICO, FILED 12-10-2010.

# Snackie's

THE MARK CONSISTS OF STANDARD CHARACTERS WITHOUT CLAIM TO ANY PARTICULAR FONT, STYLE, SIZE, OR COLOR.

FOR FRUITS AND VEGETABLES, NAMELY, PROCESSED, CANNED, DRIED AND PRESERVED FRUITS AND VEGETABLES (U.S. CL. 46).

BENJAMIN OKEKE, EXAMINING ATTORNEY

SN 85-212,088. CASTELLA IMPORTS, INC., HAUPPAUGE, NY. FILED 1-6-2011.

# FRESHALICIOUS

THE MARK CONSISTS OF STANDARD CHARACTERS WITHOUT CLAIM TO ANY PARTICULAR FONT, STYLE, SIZE, OR COLOR.

FOR PROCESSED OLIVES AND ANTIPASTO (U.S. CL. 46).

C. DIONNE CLYBURN, EXAMINING ATTORNEY

SN 85-216,828. GORTON'S INC., GLOUCESTER, MA. FILED 1-13-2011.

# SIMPLY BAKE

THE MARK CONSISTS OF STANDARD CHARACTERS WITHOUT CLAIM TO ANY PARTICULAR FONT, STYLE, SIZE, OR COLOR.

NO CLAIM IS MADE TO THE EXCLUSIVE RIGHT TO USE "BAKE", APART FROM THE MARK AS SHOWN.

FOR SEAFOOD; FROZEN SEAFOOD (U.S. CL. 46).

WENDY JUN, EXAMINING ATTORNEY

**CLASS 29—(Continued).**

SN 85-223,546. ON OPTIMUM NUTRITION LIMITED, KILKENNY CITY, IRELAND, FILED 1-21-2011.

# HYDROEGG

THE MARK CONSISTS OF STANDARD CHARACTERS WITHOUT CLAIM TO ANY PARTICULAR FONT, STYLE, SIZE, OR COLOR.

FOR PROTEIN FOR USE AS A FOOD ADDITIVE (U.S. CL. 46).

JOHN WILKE, EXAMINING ATTORNEY

**CLASS 30—STAPLE FOODS**

SN 76-700,999. CANNON CAKES, LLC, CLIFTON, NJ. FILED 12-28-2009.

# CANNON

THE MARK CONSISTS OF STANDARD CHARACTERS WITHOUT CLAIM TO ANY PARTICULAR FONT, STYLE, SIZE, OR COLOR.

FOR CAKE MIXES; CAKES; CAKES OF POPPED CEREAL GRAINS; CEREAL GRAIN MIXES FOR CAKES; FLAVORINGS FOR CAKES OF POPPED CEREAL GRAINS OTHER THAN ESSENTIAL OILS; RICE CAKES; RICE-BASED SNACK FOOD (U.S. CL. 46).

FIRST USE 10-1-2009; IN COMMERCE 10-1-2009.

CHARISMA HAMPTON, EXAMINING ATTORNEY

SN 76-702,797. MYSTIQUE COFFEE INC., MONTREAL QUEBEC, H4N 1H8, CANADA, FILED 5-4-2010.

# TOI MOI & CAFÉ

OWNER OF CANADA REG. NO. TMA758,704, DATED 2-4-2010, EXPIRES 2-4-2025.

NO CLAIM IS MADE TO THE EXCLUSIVE RIGHT TO USE "CAFÉ", APART FROM THE MARK AS SHOWN.

THE MARK CONSISTS OF THE WORDING "TOI MOI & CAFÉ" WHERE THE WORD "TOI" APPEARS HORIZONTALLY ON THE LEFT, THE WORD "MOI" APPEARS VERTICALLY TO THE RIGHT OF "TOI", THE "&" APPEARS HORIZONTALLY TO THE RIGHT OF THE LETTER "M" IN "MOI" AND THE WORD "CAFÉ" APPEARS HORIZONTALLY DIRECTLY BELOW THE "&" AND TO THE RIGHT OF THE LETTERS "OI" IN "MOI".

THE ENGLISH TRANSLATION OF "TOI MOI & CAFÉ" IN THE MARK IS "YOU ME & COFFEE".

FOR COFFEE (U.S. CL. 46).

FIRST USE 1-1-2008; IN COMMERCE 1-1-2008.

LINDA LAVACHE, EXAMINING ATTORNEY

**CLASS 30—(Continued).**

SN 76-704,075. GLUTEN FREE FABULOUS, LLC, SCOTTS-DALE, AZ. FILED 8-11-2010.



THE MARK CONSISTS OF THE STYLIZED WORDS "MAKING THE GLUTEN FREE" IN A CURVED ROW ABOVE AN OVAL THAT CONTAINS THE STYLIZED WORDS "SIMPLY SHARI'S" AND A DESIGN OF AN APPLE; BELOW THE OVAL ARE THE STYLIZED WORDS "WORLD A TASTIER PLACE" IN A CURVED ROW.

FOR GLUTEN FREE PASTAS, COOKIES, PIZZA (U.S. CL. 46).

MARY CRAWFORD, EXAMINING ATTORNEY

SN 77-290,933. SLIMM, INC., FOUNTAIN VALLEY, CA. FILED 9-27-2007.

# Slimm

THE MARK CONSISTS OF STANDARD CHARACTERS WITHOUT CLAIM TO ANY PARTICULAR FONT, STYLE, SIZE, OR COLOR.

FOR FROZEN YOGURT; BAKERY DESSERTS; FROZEN DESSERT CONSISTING OF FRUIT AND CREAM OR CREAM SUBSTITUTES (U.S. CL. 46).

ROSELLE HERRERA, EXAMINING ATTORNEY

SN 77-839,868. ARTHUR H. GARCEAU, HOLLYWOOD, FL. FILED 10-2-2009.

## DELSON LEMON COOLERS

THE MARK CONSISTS OF STANDARD CHARACTERS WITHOUT CLAIM TO ANY PARTICULAR FONT, STYLE, SIZE, OR COLOR.

NO CLAIM IS MADE TO THE EXCLUSIVE RIGHT TO USE "LEMON COOLERS", APART FROM THE MARK AS SHOWN.

FOR COOKIES (U.S. CL. 46).

RAMONA ORTIGA, EXAMINING ATTORNEY

**CLASS 30—(Continued).**

SN 77-843,612. RL GIBSON ENTERPRISES LLC, DBA GG'S FINE FOODS, WOODSTOCK, GA. FILED 10-7-2009.



NO CLAIM IS MADE TO THE EXCLUSIVE RIGHT TO USE "REAL NEW ORLEANS CREOLE CUISINE", APART FROM THE MARK AS SHOWN.

FOR SEASONINGS, NAMELY, ALL PURPOSE SEASONING FOR SEAFOOD, MEATS, POULTRY, VEGETABLES, AND OTHER FOODSTUFFS FOR RESTAURANTS, HOTELS, RESORTS, GROCERY STORES AND SPECIALTY STORES; CREOLE SEASONING FOR RESTAURANTS, HOTELS, RESORTS, GROCERY STORES AND SPECIALTY STORES; SPICE RUB FOR RESTAURANTS, HOTELS, RESORTS, GROCERY STORES AND SPECIALTY STORES; SAUCES, NAMELY, REMOULADE SAUCE FOR RESTAURANTS, HOTELS, RESORTS, GROCERY STORES AND SPECIALTY STORES; CRAWFISH PIES FOR RESTAURANTS, HOTELS, RESORTS, GROCERY STORES AND SPECIALTY STORES; CHOWDER BASE, NAMELY, SEASONING MIXES FOR RESTAURANTS, HOTELS, RESORTS, GROCERY STORES AND SPECIALTY STORES (U.S. CL. 46).

FIRST USE 7-16-2009; IN COMMERCE 7-16-2009.

APRIL ROACH, EXAMINING ATTORNEY

SN 77-858,589. GARY L. SCHMICK, SPOKANE, WA. FILED 10-27-2009.

## REBEL FLAT BARLEY CO.

THE MARK CONSISTS OF STANDARD CHARACTERS WITHOUT CLAIM TO ANY PARTICULAR FONT, STYLE, SIZE, OR COLOR.

NO CLAIM IS MADE TO THE EXCLUSIVE RIGHT TO USE "BARLEY CO.", APART FROM THE MARK AS SHOWN.

FOR FOOD, NAMELY, GRAIN-BASED SNACK FOODS AND CEREAL-BASED SNACK FOODS; AND BEVERAGES, NAMELY, TEA-BASED BEVERAGES AND TEA-BASED BEVERAGES WITH FRUIT FLAVORING; AND GRAIN-BASED BEVERAGES (U.S. CL. 46).

KIMBERLY PERRY, EXAMINING ATTORNEY

**CLASS 30—(Continued).**

SN 77-871,317. KING'S COOK FROZEN FOOD CO., TAIPING CITY, TAIWAN, FILED 11-12-2009.



NO CLAIM IS MADE TO THE EXCLUSIVE RIGHT TO USE "WWW.FROZENFOOD.COM.TW" AND "SINCE 1989", APART FROM THE MARK AS SHOWN.

THE MARK CONSISTS OF CONCENTRIC CIRCLES WITH CHINESE CHARACTERS IN THE MIDDLE WITH THE WORDS "WWW.FROZENFOOD.COM.TW" APPEARING AT THE TOP OF THE CIRCLE AND "SINCE 1989" APPEARING AT THE BOTTOM OF THE CIRCLE. THE WORDS "KING'S COOK" APPEAR ACROSS THE CIRCLE AND UNDER THE CHINESE CHARACTERS.

THE NON-LATIN CHARACTERS IN THE MARK TRANSLITERATE TO "JIN PIN" AND THIS HAS NO MEANING IN A FOREIGN LANGUAGE.

FOR FROZEN MEALS CONSISTING PRIMARILY OF RICE OR PASTA; PREPARED MEALS CONSISTING PRIMARILY OF RICE OR PASTA; BAKERY DESSERTS; BEVERAGES MADE OF COFFEE; BEVERAGES MADE OF TEA; BISCUITS AND BREAD; CAPPUCCINO; CHEESE SAUCE; CHILI SAUCE; UNCOOKED CHINESE NOODLES; CHINESE STEAMED DUMPLINGS, COOKED SHUMAI; COCOA; COCOA-BASED BEVERAGES; COFFEE; COFFEE-BASED BEVERAGES; CONDIMENT, NAMELY, PEPPER SAUCE; CORN FLOUR FOR FOOD; DUMPLINGS; FRESH PIZZA; FROZEN DOUGH FOR USE AS PIZZA, BREAD OR OTHER BREAD-TYPE PRODUCTS; HONEY; ICE CREAM; MACARONI; MACARONI AND CHEESE; MEAT GRAVIES; MEAT PIES; NOODLES AND SAUCE MIXES COMBINED IN UNITARY PACKAGES; PACKAGED MEAL MIXES CONSISTING PRIMARILY OF PASTA OR RICE; PANCAKES; PIZZA SAUCE; PREPARED PIZZAS; SANDWICHES; SAUCES; SEASONINGS; SOYA FLOUR; SPAGHETTI; SUGAR; SWEETMEATS AND WHEAT FLOUR (U.S. CL. 46).

FIRST USE 6-11-2008; IN COMMERCE 6-11-2008.  
DAWN FELDMAN, EXAMINING ATTORNEY

SN 77-916,820. PROMARK BRANDS INC., MERIDIAN, ID. FILED 1-21-2010.



OWNER OF U.S. REG. NOS. 1,186,044, 1,757,072 AND 1,941,929.

THE MARK CONSISTS OF THE WORD "NANCY'S" WITH A FLEUR-DE-LIS IN A FANCIFUL FRAME.

FOR FROZEN CHEESECAKES; FROZEN BAKERY DESSERTS (U.S. CL. 46).

COLLEEN DOMBROW, EXAMINING ATTORNEY

**CLASS 30—(Continued).**

SN 77-922,249. ISKREAM, MILFORD, CT. FILED 1-28-2010.

# I skream

THE MARK CONSISTS OF STANDARD CHARACTERS WITHOUT CLAIM TO ANY PARTICULAR FONT, STYLE, SIZE, OR COLOR.

FOR ICE CREAM; ICE CREAM SANDWICHES; ICE-CREAM CAKES (U.S. CL. 46).

LINDA M. KING, EXAMINING ATTORNEY

SN 77-953,941. CADILLAC COFFEE COMPANY, MADISON HEIGHTS, MI. FILED 3-9-2010.

# It's a Good Day

THE MARK CONSISTS OF STANDARD CHARACTERS WITHOUT CLAIM TO ANY PARTICULAR FONT, STYLE, SIZE, OR COLOR.

FOR COFFEE, SUGAR, POWDERED CAPPUCCINO, TEAS, ICED TEAS, ICED COFFEE (U.S. CL. 46).

FIRST USE 6-1-2009; IN COMMERCE 6-1-2009.  
EDWARD FENNESSY, EXAMINING ATTORNEY

SN 77-957,386. CEREALIS - PRODUTOS ALIMENTARES, S.A., AGUAS SANTAS MAIA, PORTUGAL, FILED 3-12-2010.



NO CLAIM IS MADE TO THE EXCLUSIVE RIGHT TO USE "DESDE 1849", APART FROM THE MARK AS SHOWN.

THE MARK CONSISTS OF THE STYLIZED WORDING "NACIONAL DESDE 1849" INSIDE OF A BANNER.

THE ENGLISH TRANSLATION OF "NACIONAL" AND "DESDE" IN THE MARK IS "NATIONAL" AND "FROM".

FOR PASTA (U.S. CL. 46).

FIRST USE 0-0-1849; IN COMMERCE 1-1-1980.

WILLIAM VERHOSEK, EXAMINING ATTORNEY

**CLASS 30—(Continued).**

SN 77-957,391. CERELIS - PRODUTOS ALIMENTARES, S.A., AGUAS SANTAS MAIA, PORTUGAL, FILED 3-12-2010.

# NACIONAL

THE MARK CONSISTS OF STANDARD CHARACTERS WITHOUT CLAIM TO ANY PARTICULAR FONT, STYLE, SIZE, OR COLOR.

THE ENGLISH TRANSLATION OF "NACIONAL" IN THE MARK IS "NATIONAL".

FOR PASTA (U.S. CL. 46).

FIRST USE 0-0-1849; IN COMMERCE 1-1-1980.

WILLIAM VERHOSEK, EXAMINING ATTORNEY

**CLASS 30—(Continued).**

SN 79-086,789. FLARONIS S.A., BELGIUM, FILED 6-18-2010.

# DOMINO

THE MARK CONSISTS OF STANDARD CHARACTERS WITHOUT CLAIM TO ANY PARTICULAR FONT, STYLE, SIZE, OR COLOR.

OWNER OF INTERNATIONAL REGISTRATION 0571098 DATED 5-3-1991, EXPIRES 5-3-2011.

FOR COFFEE, INSTANT COFFEE AND ARTIFICIAL COFFEE (U.S. CL. 46).

ANDREA K. NADELMAN, EXAMINING ATTORNEY

SN 79-084,202. GARIBALDI SNC DI GARIBALDI ADRIANO E C, ITALY, FILED 5-28-2010.



PRIORITY DATE OF 5-7-2010 IS CLAIMED.  
OWNER OF INTERNATIONAL REGISTRATION 1043161 DATED 5-28-2010, EXPIRES 5-28-2020.

NO CLAIM IS MADE TO THE EXCLUSIVE RIGHT TO USE "GRAN CAFFÈ", APART FROM THE MARK AS SHOWN.

THE PORTRAIT IN THE MARK DOES NOT IDENTIFY A LIVING INDIVIDUAL.

THE COLOR(S) RED, GOLD, BLACK AND WHITE IS/ARE CLAIMED AS A FEATURE OF THE MARK.

THE MARK CONSISTS OF THE FOLLOWING: THE STYLIZED WORDING "GRAN CAFFÈ GARIBALDI"; THE "GRAN CAFFÈ" NAMES ARE GOLD AND "GARIBALDI" IS RED; HIGHER THERE IS A STYLIZED SEAL DESIGN IN GOLD COLOR AND WHITE SHADING, WITH THE REPRESENTATION OF A MAN'S FACE IN BLACK, WHITE AND GOLD, IN THE INNER CIRCLE SURROUNDING THE FACE ARE SIX BLACK STARS ON THE LEFT AND RIGHT SIDES, AND TO THE UPPER RIGHT ARE TWO STYLIZED WAX DROPS WHICH ARE GOLD AND SHADED IN WHITE.

THE ENGLISH TRANSLATION OF THE FOREIGN WORD(S) IN THE MARK IS "GREAT COFFEE".

FOR COFFEE, ARTIFICIAL COFFEE, COFFEE-BASED BEVERAGES (U.S. CL. 46).

SCOTT BIBB, EXAMINING ATTORNEY

SN 79-087,066. ZICAFFÈ S.P.A., ITALY, FILED 6-22-2010.



OWNER OF INTERNATIONAL REGISTRATION 1050374 DATED 6-22-2010, EXPIRES 6-22-2020.

THE COLOR(S) BLACK, RED, YELLOW AND WHITE IS/ARE CLAIMED AS A FEATURE OF THE MARK.

THE MARK CONSISTS OF A BLACK RECTANGLE WITH THE WORDING "ZI" IN YELLOW WITH THE DOT IN THE LETTER "I" MADE FROM A RED STYLIZED COFFEE BEAN, BENEATH THE WORDING "ZI" APPEARS THE WORDING "ZICAFFÈ" IN WHITE.

FOR COFFEE BEANS AND GROUND COFFEE, COFFEE BLENDS (U.S. CL. 46).

MARILYN IZZI, EXAMINING ATTORNEY

**CLASS 30—(Continued).**

SN 79-089,319. OOO "TORGOVY DOM "SANTEK", RU-125239 MOSCOW, RUSSIAN FED., FILED 5-12-2010.

# LOVARE

OWNER OF INTERNATIONAL REGISTRATION 1056602 DATED 5-12-2010, EXPIRES 5-12-2020.

THE MARK CONSISTS OF THE WORDING "LOVARE" IN STYLIZED FONT.

THE WORDING "LOVARE" HAS NO MEANING IN A FOREIGN LANGUAGE.

FOR COFFEE; TEA; COCOA; SUGAR; RICE; TAPIOCA; SAGO; ARTIFICIAL COFFEE; FLOUR; BISCUITS; TARTS; CAKES MADE WITH CEREALS; BREAD; CONFECTIONERY MADE OF SUGAR; ICE CREAMS; HONEY; TREACLE; YEAST; BAKING-POWDER; SALT; MUSTARD; VINEGAR; SEASONINGS; SPICES; EDIBLE ICES (U.S. CL. 46).

KAREN SEVERSON, EXAMINING ATTORNEY

---

SN 85-001,208. MOLINOS VALLE DEL CIBAO, C POR A, SANTIAGO, DOMINICAN REP, FILED 3-29-2010.

OWNER OF DOMINICAN REP REG. NO. 176414, DATED 9-30-2009, EXPIRES 9-30-2019.

THE COLOR(S) BLUE, LIGHT BLUE, PINK, AND WHITE IS/ARE CLAIMED AS A FEATURE OF THE MARK.

THE MARK CONSISTS OF THE WORD "QIIN" APPEARING IN WHITE AND OUTLINED IN LIGHT BLUE, BLUE AND PINK AND THE "I"'S ARE DOTTED WITH SQUARE SHAPES FILLED WITH PINK AND OUTLINED IN BLUE.

FOR FLOURS AND CEREAL-BASED MIXES FOR MAKING SWEET AND SALTED COOKIES (U.S. CL. 46).  
RAMONA ORTIGA, EXAMINING ATTORNEY

---

SN 85-001,332. ENGBERG HOLDING LLC, DBA PINKABELLA, KIRKLAND, WA. FILED 3-29-2010.

# PinkaBella

THE MARK CONSISTS OF STANDARD CHARACTERS WITHOUT CLAIM TO ANY PARTICULAR FONT, STYLE, SIZE, OR COLOR.

FOR BAKERY PRODUCTS, NAMELY, SWEET BAKERY GOODS (U.S. CL. 46).

FIRST USE 3-1-2010; IN COMMERCE 3-1-2010.

KATHRYN COWARD, EXAMINING ATTORNEY

**CLASS 30—(Continued).**

SN 85-004,110. TYPHOO TEA LIMITED, MERSEYSIDE, UNITED KINGDOM, FILED 4-1-2010.

# LIFT

THE MARK CONSISTS OF STANDARD CHARACTERS WITHOUT CLAIM TO ANY PARTICULAR FONT, STYLE, SIZE, OR COLOR.

PRIORITY CLAIMED UNDER SEC. 44(D) ON ERP N CMNTY TM OFC APPLICATION NO. 8737702, FILED 12-7-2009, REG. NO. 008737702, DATED 1-7-2011, EXPIRES 1-7-2021.

FOR TEA; INSTANT TEA; INSTANT FLAVOURED TEA; FRUIT FLAVOURED TEA; NONE OF OTHER AFOREMENTIONED GOODS IN A LIQUID READY TO DRINK FORM (U.S. CL. 46).

JOSETTE BEVERLY, EXAMINING ATTORNEY

---

SN 85-005,678. WADE, HEATHER, DBA BAKETTE, SILVER SPRING, MD. FILED 4-3-2010.

# Bakette

THE MARK CONSISTS OF STANDARD CHARACTERS WITHOUT CLAIM TO ANY PARTICULAR FONT, STYLE, SIZE, OR COLOR.

FOR BREAD AND PASTRY; CANDIES; CANDY BARS; CANDY CAKE DECORATIONS; COOKIES; PASTRIES; PIE CRUSTS (U.S. CL. 46).

FIRST USE 2-1-2010; IN COMMERCE 2-1-2010.

SETH A. RAPPAPORT, EXAMINING ATTORNEY

**CLASS 30—(Continued).**

SN 85-007,205. NEW ENGLAND CONFECTIONERY COMPANY, INC., REVERE, MA. FILED 4-6-2010.



NO CLAIM IS MADE TO THE EXCLUSIVE RIGHT TO USE "ALL NATURAL", APART FROM THE MARK AS SHOWN.

THE MARK CONSISTS OF A UNIQUE PAINT SPLATTER DESIGN WITH THE WORDS "GET REAL ALL NATURAL" SUPERIMPOSED OVER THE DESIGN.

FOR CANDY BARS, CHOCOLATE, AND CHOCOLATE CANDIES ALL MADE FROM ALL NATURAL INGREDIENTS (U.S. CL. 46).

FIRST USE 3-26-2010; IN COMMERCE 3-26-2010.  
MICHAEL WEBSTER, EXAMINING ATTORNEY

SN 85-008,910. LAGUDI, CYNTHIA, DBA CUPCAKE PROVOCATEUR CUPCAKES, OCEANSIDE, NY. FILED 4-7-2010.



NO CLAIM IS MADE TO THE EXCLUSIVE RIGHT TO USE "CUPCAKE", APART FROM THE MARK AS SHOWN.

THE LIKENESS IN THE MARK IDENTIFIES CYNTHIA LAGUDI, A LIVING INDIVIDUAL WHOSE CONSENT IS OF RECORD.

THE COLOR(S) PINK, BLACK, BROWN, WHITE, RED, BLUE, PALE YELLOW, AND GREEN IS/ARE CLAIMED AS A FEATURE OF THE MARK.

THE MARK CONSISTS OF THE DESIGN OF A PINUP-STYLE WOMAN SITTING ON A LARGE CUPCAKE. THE WOMAN HAS BLACK EYES, BROWN HAIR, WHITE SKIN WITH RED LIPS AND A SLIGHT SMILE. SHE IS WEARING A PINK AND BLACK APRON WITH PINK BOWS, AS WELL AS BLACK AND PINK PANTIES WITH PINK POLKA DOTS, PINK GARTER BELT STOCKINGS AND BLACK HEELS WITH PINK ACCENTS. SHE IS WEARING A PINK BOW IN HER HAIR AND RED CHERRY-SHAPED EARRINGS. THE WOMAN IS HOLDING A LIGHT BLUE AND PALE YEL-

**CLASS 30—(Continued).**

LOW CUPCAKE AND IS SITTING ON A LARGE CUPCAKE WITH A BLUE TOP, PALE YELLOW BASE WITH BLACK LINING, RED HEART-SHAPED SPRINKLES AND WITH A RED CHERRY WITH A GREEN STEM ON TOP. THE DESIGN OF THE PINUP AND CUPCAKE IS ON A PINK OVAL BACKGROUND OUTLINED IN BLACK WITH A BLACK TOILE DESIGN ON TOP AND A LARGE FLEUR DE LYS ON THE BOTTOM UNDER THE LARGE CUPCAKE. UNDERNEATH ARE THE WORDS "CUPCAKE PROVOCATEUR" IN PINK WITH BLACK OUTLINING.

FOR BAKERY DESSERTS; BAKERY GOODS; BAKERY PRODUCTS; BAKERY PRODUCTS, NAMELY, SWEET BAKERY GOODS; MIXES FOR BAKERY GOODS (U.S. CL. 46).

FIRST USE 7-30-2008; IN COMMERCE 10-1-2008.  
DOUGLAS LEE, EXAMINING ATTORNEY

SN 85-012,976. SCHLOTZSKY'S FRANCHISE LLC, ATLANTA, GA. FILED 4-13-2010.

**SCHLOTZSKY'S**

THE MARK CONSISTS OF STANDARD CHARACTERS WITHOUT CLAIM TO ANY PARTICULAR FONT, STYLE, SIZE, OR COLOR.

OWNER OF U.S. REG. NOS. 1,337,033, 2,235,917 AND 3,182,401.

FOR FOOD PRODUCTS, NAMELY, SANDWICHES, PANINI, PIZZA, PIZZA CRUST, PASTA, PASTA SALAD, BREADS, BREAD DOUGH, BUNS, BREAD ROLLS, CRACKERS, CROUTONS, TORTILLAS, TORTILLA CHIPS, CORN CHIPS, CORN-BASED SNACK FOODS, PRETZELS, BAKERY GOODS, MIXES FOR BAKERY GOODS, COOKIES, CAKES, CHEESECAKE, BROWNIES, SALAD DRESSINGS, SAUCES, BARBECUE SAUCE, TOMATO SAUCE, HOT SAUCE, FISH SAUCE, MAYONNAISE, MUSTARD, VINEGAR, FLAVORED VINEGAR, PROCESSED HERBS, SPICES, SALT, PEPPER, CONDIMENT, NAMELY, PEPPER SAUCE, FRUIT SAUCES EXCLUDING CRANBERRY SAUCE AND APPLESAUCE (U.S. CL. 46).

FIRST USE 8-11-1971; IN COMMERCE 8-11-1971.  
DEZMONA MIZELLE, EXAMINING ATTORNEY

SN 85-015,178. LA BRISA ICE CREAM COMPANY, HOUSTON, TX. FILED 4-15-2010.

**DIABLITO**

THE MARK CONSISTS OF STANDARD CHARACTERS WITHOUT CLAIM TO ANY PARTICULAR FONT, STYLE, SIZE, OR COLOR.

THE ENGLISH TRANSLATION OF "DIABLITO" IN THE MARK IS "LITTLE DEVIL".

FOR FROZEN CONFECTIONS, FRUIT ICE BARS, ICE MILK BARS, FROZEN FRUIT BARS (U.S. CL. 46).

FIRST USE 2-14-2010; IN COMMERCE 2-14-2010.  
JEAN IM, EXAMINING ATTORNEY

**CLASS 30—(Continued).**

SN 85-021,252. FRESH-CO INVESTMENTS LLC, RIO RICO, AZ. FILED 4-22-2010.

**CLASS 30—(Continued).**

SN 85-026,725. KAHALA FRANCHISING, L.L.C., SCOTTSDALE, AZ. FILED 4-29-2010.

**AQUA DREAM FROZEN YOGURT**

THE MARK CONSISTS OF STANDARD CHARACTERS WITHOUT CLAIM TO ANY PARTICULAR FONT, STYLE, SIZE, OR COLOR.

NO CLAIM IS MADE TO THE EXCLUSIVE RIGHT TO USE "FROZEN YOGURT", APART FROM THE MARK AS SHOWN.

FOR FROZEN YOGURT WITH OR WITHOUT TOP-PINGS; FROZEN CONFECTIONS, NAMELY, FROZEN YOGURT-BASED DESSERTS, IN PLAIN FORM OR WITH ADDED INGREDIENTS SUCH AS FRUIT, NUTS, AND CANDY; FROZEN YOGURT MIXES; FROZEN CUSTARDS; FROZEN DESSERTS CONSISTING OF FRUIT AND CREAM OR CREAM SUBSTITUTES; FROZEN YOGURT BARS (U.S. CL. 46).

TRACY WHITTAKER-BROWN, EXAMINING ATTORNEY



SN 85-025,540. GRUPO BIMBO, S.A.B DE C.V., MEXICO CITY 01210, MEXICO, FILED 4-28-2010.

**JELLYZARD**

THE MARK CONSISTS OF STANDARD CHARACTERS WITHOUT CLAIM TO ANY PARTICULAR FONT, STYLE, SIZE, OR COLOR.

OWNER OF MEXICO REG. NO. 1015421, DATED 11-30-2007, EXPIRES 11-30-2017.

FOR GUMMY CANDIES (U.S. CL. 46).  
CHRIS WELLS, EXAMINING ATTORNEY

NO CLAIM IS MADE TO THE EXCLUSIVE RIGHT TO USE "MADE FRESH DAILY", "SMOOTH AND CREAMY" AND "CONE", APART FROM THE MARK AS SHOWN.

THE COLOR(S) RED, WHITE AND GOLD IS/ARE CLAIMED AS A FEATURE OF THE MARK.

THE MARK CONSISTS OF A CIRCLE WITH A RIBBON-LIKE BORDER ON THE OUTSIDE AND SMOOTH BORDER ON THE INSIDE. THE INSIDE OF THE CIRCLE IS RED AND THE BORDER IS GOLD. THE WORDS "SMOOTH & CREAMY MADE FRESH DAILY" APPEAR AROUND THE INSIDE OF THE CIRCLE IN WHITE LETTERS. THE WORDS "SMOOTH & CREAMY" ARE SEPARATED FROM THE WORDS "MADE FRESH DAILY" BY A SOLID SPHERE AT THE TOP CENTER OF THE CIRCLE. A GOLD BANNER WITH THE WORDS "GOLD CONE" CENTERED AND APPEARING IN WHITE AND A GOLD MEDALLION WITH AN IMPRINT OF AN ICE CREAM CONE LOCATED ABOVE AND CENTERED OVER THE BANNER IS CENTERED AT THE BOTTOM OF THE CIRCLE.

FOR FROZEN CONFECTIONS; FROZEN CONFECTIONS, NAMELY, ICE CREAM, FROZEN YOGURT AND SORBETS, ALL OF THE FOREGOING IN PLAIN FORM OR CUSTOM-BLENDED WITH MIX-INS, SUCH AS CANDY, FRUITS, AND NUTS; ICE CREAM PIES; ICE CREAM CAKES; ICE CREAM CUPCAKES; SUNDAES AND SHAKES (U.S. CL. 46).

GINA HAYES, EXAMINING ATTORNEY

**CLASS 30—(Continued).**

SN 85-026,771. KAHALA FRANCHISING, L.L.C., SCOTTSDALE, AZ. FILED 4-29-2010.



NO CLAIM IS MADE TO THE EXCLUSIVE RIGHT TO USE "CONE", APART FROM THE MARK AS SHOWN.

THE COLOR(S) GOLD AND WHITE IS/ARE CLAIMED AS A FEATURE OF THE MARK.

THE MARK CONSISTS OF A GOLD BANNER WITH THE WORDS "GOLD CONE" CENTERED AND APPEARING IN WHITE. A GOLD MEDALLION WITH AN IMPRINT OF AN ICE CREAM CONE IS LOCATED ABOVE AND CENTERED OVER THE BANNER.

FOR FROZEN CONFECTIONS; FROZEN CONFECTIONS, NAMELY, ICE CREAM, FROZEN YOGURT AND SORBETS, ALL OF THE FOREGOING IN PLAIN FORM OR CUSTOM-BLENDED WITH MIX-INS, SUCH AS CANDY, FRUITS, AND NUTS; ICE CREAM PIES; ICE CREAM CAKES; ICE CREAM CUPCAKES; SUNDAES AND SHAKES (U.S. CL. 46).

GINA HAYES, EXAMINING ATTORNEY

SN 85-029,553. KAHALA FRANCHISING, L.L.C., SCOTTSDALE, AZ. FILED 5-4-2010.



NO CLAIM IS MADE TO THE EXCLUSIVE RIGHT TO USE "MADE FRESH DAILY", "SMOOTH AND CREAMY", "FLAVOR OF THE MONTH" AND "CONE", APART FROM THE MARK AS SHOWN.

THE COLOR(S) RED, WHITE AND GOLD IS/ARE CLAIMED AS A FEATURE OF THE MARK.

THE MARK CONSISTS OF A SQUARE WITH A SMOOTH BORDER. THE INSIDE OF THE SQUARE HAS A DARK RED BACKGROUND WITH A LIGHTER RED SWIRL DESIGN AND THE BORDER OF THE SQUARE IS GOLD. THE WORDS "MADE FRESH DAILY" APPEAR IN WHITE

**CLASS 30—(Continued).**

ON THE LEFT SIDE OF THE SQUARE. THE WORDS "FLAVOR OF THE MONTH" APPEAR IN WHITE AT THE TOP OF THE SQUARE. THE WORDS SMOOTH & CREAMY APPEAR IN WHITE ON THE RIGHT SIDE OF THE SQUARE. A GOLD BANNER WITH THE WORDS "GOLD CONE" CENTERED AND APPEARING IN WHITE AND A GOLD MEDALLION WITH AN IMPRINT OF AN ICE CREAM CONE LOCATED ABOVE AND CENTERED OVER THE BANNER IS CENTERED AT THE BOTTOM OF THE SQUARE.

FOR FROZEN CONFECTIONS; FROZEN CONFECTIONS, NAMELY, ICE CREAM, FROZEN YOGURT AND SORBETS, ALL OF THE FOREGOING IN PLAIN FORM OR CUSTOM-BLENDED WITH MIX-INS, SUCH AS CANDY, FRUITS, AND NUTS; ICE CREAM PIES; ICE CREAM CAKES; ICE CREAM CUPCAKES; SUNDAES AND SHAKES (U.S. CL. 46).

GINA HAYES, EXAMINING ATTORNEY

SN 85-029,590. KAHALA FRANCHISING, L.L.C., SCOTTSDALE, AZ. FILED 5-4-2010.

**KEY LIME SUNSHINE**

THE MARK CONSISTS OF STANDARD CHARACTERS WITHOUT CLAIM TO ANY PARTICULAR FONT, STYLE, SIZE, OR COLOR.

NO CLAIM IS MADE TO THE EXCLUSIVE RIGHT TO USE "KEY LIME", APART FROM THE MARK AS SHOWN.

FOR FROZEN CONFECTIONS; ICE CREAM; ICE CREAM DESSERTS (U.S. CL. 46).

GINA HAYES, EXAMINING ATTORNEY

SN 85-029,691. KAHALA FRANCHISING, L.L.C., SCOTTSDALE, AZ. FILED 5-4-2010.

**PINEAPPLE KEY LIME PUCKER**

THE MARK CONSISTS OF STANDARD CHARACTERS WITHOUT CLAIM TO ANY PARTICULAR FONT, STYLE, SIZE, OR COLOR.

NO CLAIM IS MADE TO THE EXCLUSIVE RIGHT TO USE "PINEAPPLE KEY LIME", APART FROM THE MARK AS SHOWN.

FOR FROZEN CONFECTIONS; ICE CREAM; ICE CREAM DESSERTS (U.S. CL. 46).

GINA HAYES, EXAMINING ATTORNEY



**CLASS 30—(Continued).**

SN 85-030,247. KAHALA FRANCHISING, L.L.C., SCOTTS-DALE, AZ. FILED 5-4-2010.

# WHAT A PEACH

THE MARK CONSISTS OF STANDARD CHARACTERS WITHOUT CLAIM TO ANY PARTICULAR FONT, STYLE, SIZE, OR COLOR.

NO CLAIM IS MADE TO THE EXCLUSIVE RIGHT TO USE "PEACH", APART FROM THE MARK AS SHOWN.

FOR FROZEN CONFECTIONS; ICE CREAM; ICE CREAM DESSERTS (U.S. CL. 46).

GINA HAYES, EXAMINING ATTORNEY

**CLASS 30—(Continued).**

SN 85-033,759. EUGENEJ, LLC, FLUSHING, NY. FILED 5-9-2010.

# FICKELGRUBER

THE MARK CONSISTS OF STANDARD CHARACTERS WITHOUT CLAIM TO ANY PARTICULAR FONT, STYLE, SIZE, OR COLOR.

FOR CANDY (U.S. CL. 46).

JOHN E. MICHOS, EXAMINING ATTORNEY

SN 85-030,253. KAHALA FRANCHISING, L.L.C., SCOTTS-DALE, AZ. FILED 5-4-2010.

# SWEET AS A PEACH PIE

THE MARK CONSISTS OF STANDARD CHARACTERS WITHOUT CLAIM TO ANY PARTICULAR FONT, STYLE, SIZE, OR COLOR.

NO CLAIM IS MADE TO THE EXCLUSIVE RIGHT TO USE "PEACH PIE", APART FROM THE MARK AS SHOWN.

FOR FROZEN CONFECTIONS; ICE CREAM; ICE CREAM DESSERTS (U.S. CL. 46).

GINA HAYES, EXAMINING ATTORNEY

SN 85-038,146. OROGRAIN BAKERIES PRODUCTS, INC., HORSHAM, PA. FILED 5-13-2010.

# ENTENMANN'S PANCAKE POCKETS

THE MARK CONSISTS OF STANDARD CHARACTERS WITHOUT CLAIM TO ANY PARTICULAR FONT, STYLE, SIZE, OR COLOR.

OWNER OF U.S. REG. NOS. 976,025, 3,116,183 AND OTHERS.

NO CLAIM IS MADE TO THE EXCLUSIVE RIGHT TO USE "PANCAKE POCKETS", APART FROM THE MARK AS SHOWN.

FOR BAKERY PRODUCTS (U.S. CL. 46).

GISELLE AGOSTO, EXAMINING ATTORNEY

SN 85-033,294. LIPARI FOODS, INC., WARREN, MI. FILED 5-7-2010.



NO CLAIM IS MADE TO THE EXCLUSIVE RIGHT TO USE "BAKERY" AND "FRESHLY BAKED", APART FROM THE MARK AS SHOWN.

FOR BAKERY GOODS (U.S. CL. 46).

MARY CRAWFORD, EXAMINING ATTORNEY

SN 85-052,578. FARLEY'S & SATHERS CANDY COMPANY, INC., ROUND LAKE, MN. FILED 6-2-2010.

# BIG BOLD BEARS

THE MARK CONSISTS OF STANDARD CHARACTERS WITHOUT CLAIM TO ANY PARTICULAR FONT, STYLE, SIZE, OR COLOR.

NO CLAIM IS MADE TO THE EXCLUSIVE RIGHT TO USE "BEARS", APART FROM THE MARK AS SHOWN.

FOR CANDY (U.S. CL. 46).

ALEXANDER L. POWERS, EXAMINING ATTORNEY

**CLASS 30—(Continued).**

SN 85-058,590. BLANKEN, DOUGLAS P., BATESVILLE, IN. AND BLANKEN, KATHRYN ELOIZA, BATESVILLE, IN. FILED 6-9-2010.

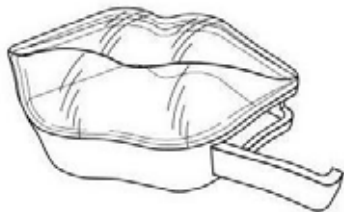

OWNER OF U.S. REG. NO. 3,765,106.  
THE MARK CONSISTS OF THE THREE DIMENSIONAL CONFIGURATION OF THE PACKAGING FOR THE GOODS, NAMELY, A CONTAINER FOR BREATH MINTS HAVING A LOWER RECEPTACLE SECTION AND AN UPPER, TRANSPARENT LID SECTION BOTH OF WHICH ARE LIP-SHAPED. THE UPPER SURFACE OF THE LID SECTION IS CONFIGURED TO RESEMBLE A PAIR OF RAISED LIPS.

FOR CANDY MINTS (U.S. CL. 46).  
SUSAN RICHARDS, EXAMINING ATTORNEY

SN 85-063,964. GARDEN FRESH SALSA COMPANY, INC., FERNDALE, MI. FILED 6-16-2010.

**GARDEN FRESH GOURMET  
ITALIANO**

THE MARK CONSISTS OF STANDARD CHARACTERS WITHOUT CLAIM TO ANY PARTICULAR FONT, STYLE, SIZE, OR COLOR.

NO CLAIM IS MADE TO THE EXCLUSIVE RIGHT TO USE "FRESH GOURMET ITALIANO", APART FROM THE MARK AS SHOWN.

THE ENGLISH TRANSLATION OF "ITALIANO" IN THE MARK IS "ITALIAN".

FOR PASTA SAUCE, PESTO SAUCE, SPAGHETTI SAUCE, TOMATO SAUCE, PASTA, SPAGHETTI, AND NOODLES (U.S. CL. 46).

DOUGLAS LEE, EXAMINING ATTORNEY

SN 85-070,446. NATIONAL CONEY ISLAND, INC., ROSEVILLE, MI. FILED 6-24-2010.

**Hani**

THE MARK CONSISTS OF STANDARD CHARACTERS WITHOUT CLAIM TO ANY PARTICULAR FONT, STYLE, SIZE, OR COLOR.

THE WORDING "HANI" HAS NO MEANING IN A FOREIGN LANGUAGE.

FOR SANDWICHES (U.S. CL. 46).  
FIRST USE 1-1-1980; IN COMMERCE 1-1-1980.  
ANDREW RHIM, EXAMINING ATTORNEY

**CLASS 30—(Continued).**

SN 85-071,800. COOK, DONALD M., BROOKLYN, NY. AND COOK, GWENDOLYN, BROOKLYN, NY. FILED 6-25-2010.



NO CLAIM IS MADE TO THE EXCLUSIVE RIGHT TO USE "HOME-STYLE BARBECUE SAUCE", APART FROM THE MARK AS SHOWN.

THE NAME(S), PORTRAIT(S), AND/OR SIGNATURE(S) SHOWN IN THE MARK IDENTIFIES DAISY ALMETA COOK A/K/A "BEZZIE" COOK, WHOSE CONSENT(S) TO REGISTER IS MADE OF RECORD.

THE MARK CONSISTS OF THE TERM, "BEZZIE'S", UNDERNEATH A DESIGN CONSISTING OF AN IMAGE OF BEZZIE COOK DISPLAYED WITHIN A CIRCLE, ABOVE WHICH THE TERMS "HOME-STYLE BARBECUE SAUCE" ARE DISPLAYED, THE TERMS BEING BRACKETED BETWEEN TWO STAR SHAPES.

FOR BARBECUE SAUCE; CHICKEN WING SAUCE; DIPPING SAUCES; READY-MADE SAUCES; SAUCES; SAUCES FOR BARBECUED MEAT (U.S. CL. 46).

FIRST USE 6-14-2010; IN COMMERCE 6-14-2010.  
BRIDGETT SMITH, EXAMINING ATTORNEY

SN 85-093,921. KELLOGG NORTH AMERICA COMPANY, BATTLE CREEK, MI. FILED 7-27-2010.



OWNER OF U.S. REG. NO. 3,395,400.

NO CLAIM IS MADE TO THE EXCLUSIVE RIGHT TO USE "CRUNCHY NUT", APART FROM THE MARK AS SHOWN.

THE COLOR(S) BLACK, WHITE AND YELLOW IS/ARE CLAIMED AS A FEATURE OF THE MARK.

THE MARK CONSISTS OF THE STYLIZED WORDS "CRUNCHY NUT" IN BLACK LETTERING OUTLINED IN WHITE ALL ON A YELLOW BACKGROUND WITH THE LETTER "C" IN THE WORD "CRUNCHY" SHOWING THE FOLLOWING LETTER "R" BEING CRUMBLED.

FOR BREAKFAST CEREALS; GRANOLA-BASED SNACK BARS (U.S. CL. 46).  
MICHAEL GAAFAR, EXAMINING ATTORNEY

**CLASS 30—(Continued).**

SN 85-097,523. THE ORIGINAL FRIED PIE SHOP, INC., GARLAND, TX. FILED 7-31-2010.



NO CLAIM IS MADE TO THE EXCLUSIVE RIGHT TO USE "THE ORIGINAL FRIED PIE SHOP", APART FROM THE MARK AS SHOWN.

THE COLOR(S) RED, WHITE AND BLACK IS/ARE CLAIMED AS A FEATURE OF THE MARK.

THE MARK CONSISTS OF A RED AND WHITE CHECKERBOARD OVAL BORDER ENCLOSING THE WORDS "THE ORIGINAL" IN BLACK LAUREN SCRIPT REGULAR FONT ON THE FIRST LINE; "FRIED PIE" IN RED QTR KOOPER FONT ON THE SECOND LINE, AND "SHOP" IN BLACK QTR KOOPER FONT ON THE THIRD LINE; A CURVED LINE MOTIF APPEARS BEFORE AND AFTER THE WORD "SHOP".

FOR FRIED PIES FILLED WITH FRUIT, MEAT, EGGS, CHEESE, VEGETABLES OR FLAVORED CREAMS OR VARIOUS COMBINATIONS OF THE FOREGOING (U.S. CL. 46).

FIRST USE 1-5-2010; IN COMMERCE 1-5-2010.  
PAM WILLIS, EXAMINING ATTORNEY

SN 85-099,486. SUCESORES PEDRO CORTES, INC., SAN JUAN, PUERTO RICO, FILED 8-3-2010.

## Chocolate Cortés

THE MARK CONSISTS OF STANDARD CHARACTERS WITHOUT CLAIM TO ANY PARTICULAR FONT, STYLE, SIZE, OR COLOR.

OWNER OF U.S. REG. NO. 3,645,785.

NO CLAIM IS MADE TO THE EXCLUSIVE RIGHT TO USE "CHOCOLATE", APART FROM THE MARK AS SHOWN.

THE NAME(S), PORTRAIT(S), AND/OR SIGNATURE(S) SHOWN IN THE MARK DOES NOT IDENTIFY A PARTICULAR LIVING INDIVIDUAL.

FOR CHOCOLATE; CHOCOLATE BARS (U.S. CL. 46).

FIRST USE 8-1-1951; IN COMMERCE 8-1-1951.

THEODORE MCBRIDE, EXAMINING ATTORNEY

**CLASS 30—(Continued).**

SN 85-107,572. LAKE, MARY E., DBA KONA LISA COFFEE, CAPTAIN COOK, HI. FILED 8-13-2010.



NO CLAIM IS MADE TO THE EXCLUSIVE RIGHT TO USE "KONA", "COFFEE" AND "100% KONA COFFEE", APART FROM THE MARK AS SHOWN.

THE COLOR(S) BLACK, WHITE, PURPLE, RED, GREEN, TAN AND YELLOW IS/ARE CLAIMED AS A FEATURE OF THE MARK.

THE MARK CONSISTS OF THE COLORS BLACK AND TAN APPEARING IN THE DEPICTION OF THE MONA LISA, WHO IS HOLDING A CUP ARREARING IN THE COLOR WHITE, AND IS WEARING A FLORAL WREATH APPEARING IN THE COLORS PURPLE, WHITE AND YELLOW, ALL OVER A BLACK AND TAN AND GREEN BACKGROUND CONTAINING A RIVER APPEARING IN THE COLOR RED. AT THE TOP OF WHICH IS THE TEXT "PUT A SMILE ON YOUR FACE" APPEARING IN THE COLOR BLACK, ALL OF WHICH APPEARS WITHIN A RED BORDER, WHICH IS SURROUNDED BY A BLACK BORDER CONTAINING THE TEXT "KONA LISA COFFEE" AND "100% KONA COFFEE", BOTH OF WHICH APPEAR IN THE COLOR WHITE, AND ALL OF WHICH APPEARS WITHIN A THREE-SIDED RED BORDER.

FOR ROASTED COFFEE BEANS (U.S. CL. 46).

FIRST USE 0-0-2005; IN COMMERCE 0-0-2005.

RONALD AIKENS, EXAMINING ATTORNEY

SN 85-109,050. PAK-INDO, LLC, DBA TRADE ROUTES, LENEXA, KS. FILED 8-17-2010.



NO CLAIM IS MADE TO THE EXCLUSIVE RIGHT TO USE "A TRADITIONAL BAKERY", APART FROM THE MARK AS SHOWN.

THE COLOR(S) WHITE, BROWN AND LIGHT BROWN IS/ARE CLAIMED AS A FEATURE OF THE MARK.

THE MARK CONSISTS OF THE STYLIZED WORDING "TRADE ROUTES" IN BROWN. BELOW IS THE STYLIZED WORDING "A TRADITIONAL BAKERY" IN BROWN. ABOVE THE WORDING IS A DESIGN OF A CITY SKYLINE WITH A LIGHT BROWN BACKGROUND FEATURING TREES AND VARIOUS BUILDINGS IN BROWN AND CAMELS AND PEOPLE IN WHITE.

FOR BREAD; PITA BREAD (U.S. CL. 46).

FIRST USE 8-15-2009; IN COMMERCE 8-15-2009.

JESSICA FATHY, EXAMINING ATTORNEY

**CLASS 30—(Continued).**

SN 85-122,141. KELLOGG NORTH AMERICA COMPANY, BATTLE CREEK, MI. FILED 9-2-2010.

**POP-TARTS MINI CRISPS**

THE MARK CONSISTS OF STANDARD CHARACTERS WITHOUT CLAIM TO ANY PARTICULAR FONT, STYLE, SIZE, OR COLOR.

OWNER OF U.S. REG. NOS. 791,514, 1,671,971 AND OTHERS.

NO CLAIM IS MADE TO THE EXCLUSIVE RIGHT TO USE "MINI CRISPS", APART FROM THE MARK AS SHOWN.

FOR CRACKERS (U.S. CL. 46).

MICHAEL GAAFAR, EXAMINING ATTORNEY

SN 85-123,633. VIOLETTI, NICOLE S, DBA CAVE GIRL CAFE, CHICO, CA. AND ZELICK, VICTORIA A, DBA CAVE GIRL CAFE, CHICO, CA. FILED 9-6-2010.



NO CLAIM IS MADE TO THE EXCLUSIVE RIGHT TO USE "CAFE", APART FROM THE MARK AS SHOWN.

THE COLOR(S) TEAL BLUE, LIGHT BLUE, BLACK, WHITE, BROWN, ORANGE, PINK, FLESH AND GRAY IS/ARE CLAIMED AS A FEATURE OF THE MARK.

THE MARK CONSISTS OF THE WORD "CAVE GIRL", WRITTEN IN "FABULOUS 50'S" FONT, IN THE COLOR TEAL BLUE AND OUTLINED IN BLACK, CURVED ACROSS THE TOP OF TWO FLESH COLORED GIRLS, SITTING BACK TO BACK IN AN OVAL WITH A BLACK OUTLINE. THE GIRL ON THE LEFT HAS BROWN HAIR, BLUE EYES, BLUE EYE SHADOW, PINK LIPS, AND WHITE TEETH. SHE IS WEARING AN ORANGE AND BLACK LEOPARD SKIN HALTER TOP AND TATTERED SKIRT WITH WHITE PEARLS AROUND HER NECK AND ANKLE. IN HER RIGHT HAND SHE IS HOLDING A BROWN AND WHITE DRUM STICK. THE GIRL ON THE RIGHT HAS BLACK HAIR WITH A WHITE AND BROWN BONE AS A CLIP. SHE HAS BLUE EYES, BLUE EYE SHADOW, PINK LIPS, WHITE TEETH AND IS WEARING A BLACK AND WHITE ZEBRA STRIPED HALTER TOP AND TATTERED SKIRT ALONG WITH WHITE PEARLS AROUND HER NECK AND ANKLES. SHE IS HOLDING A BROWN SPEAR WITH A GRAY TIP, FACING DOWNWARD IN SOUTH-WEST DIRECTION. THE GIRLS ARE SITTING IN A BLACK OVAL WITH A LIGHT BLUE BACKGROUND. CENTERED AT THE BASE OF THE OVAL IS A BLACK TRAPEZOID WITH AN INNER LIGHT BLUE OUTLINE, WITH THE WORD "CAFE" IN WHITE, TYPED IN "FABULOUS 50'S" FONT CENTERED IN THE TRAPEZOID.

FOR COFFEE AND TEA (U.S. CL. 46).

FIRST USE 9-1-2010; IN COMMERCE 9-1-2010.

TINA L. SNAPP, EXAMINING ATTORNEY

**CLASS 30—(Continued).**

SN 85-125,765. MATE REVOLUTION INC., DBA ECOTEAS, ASHLAND, OR. FILED 9-9-2010.



NO CLAIM IS MADE TO THE EXCLUSIVE RIGHT TO USE "TEAS", "ORGANIC", OR "FAIR TRADE", APART FROM THE MARK AS SHOWN.

THE COLOR(S) BROWN IS/ARE CLAIMED AS A FEATURE OF THE MARK.

THE MARK CONSISTS OF THE WORDS "ECO TEAS" (ABOVE) IN BROWN BASTARD FONT AND "ORGANIC & FAIR TRADE" (BELOW) IN BROWN HELVETICA FONT; THE WORDS "ECO" AND "TEAS" ARE SPLIT BY A STYLIZED IMAGE OF A BROWN SPIRAL-ADORNED TEA CUP (MATE) AND A TEA STRAW (BOMBILLA).

FOR ORGANIC HERBAL TEAS (U.S. CL. 46).

FIRST USE 6-1-2010; IN COMMERCE 6-1-2010.

PAM WILLIS, EXAMINING ATTORNEY

SN 85-134,271. THE PILLSBURY COMPANY, LLC, MINNEAPOLIS, MN. FILED 9-21-2010.

**TRIPLE BERRY BLAST**

THE MARK CONSISTS OF STANDARD CHARACTERS WITHOUT CLAIM TO ANY PARTICULAR FONT, STYLE, SIZE, OR COLOR.

NO CLAIM IS MADE TO THE EXCLUSIVE RIGHT TO USE "TRIPLE BERRY", APART FROM THE MARK AS SHOWN.

FOR FRENCH TOAST (U.S. CL. 46).

CAROLYN CATALDO, EXAMINING ATTORNEY

SN 85-134,275. THE PILLSBURY COMPANY, LLC, MINNEAPOLIS, MN. FILED 9-21-2010.

**CINNAMON RUSH**

THE MARK CONSISTS OF STANDARD CHARACTERS WITHOUT CLAIM TO ANY PARTICULAR FONT, STYLE, SIZE, OR COLOR.

NO CLAIM IS MADE TO THE EXCLUSIVE RIGHT TO USE "CINNAMON", APART FROM THE MARK AS SHOWN.

FOR FRENCH TOAST (U.S. CL. 46).

CAROLYN CATALDO, EXAMINING ATTORNEY

**CLASS 30—(Continued).**

SN 85-139,846. ORIENTAL PACKING CO., INC., MIAMI, FL. FILED 9-28-2010.



NO CLAIM IS MADE TO THE EXCLUSIVE RIGHT TO USE "JAMAICAN", APART FROM THE MARK AS SHOWN.

THE COLOR(S) WHITE, RED, GREEN, LIGHT GREEN, LIGHT YELLOW, YELLOW, GRAY AND BLACK IS/ARE CLAIMED AS A FEATURE OF THE MARK.

THE MARK CONSISTS OF THE STYLIZED WORDING "SIMPLY JAMAICAN". THE WORD "SIMPLY" IN RED CURSIVE WRITING OUTLINED IN BLACK AND WHITE ON THE TOP OF THE WORD "JAMAICAN" OUTLINED IN BLACK AND WHITE IN BLOCK LETTERS APPEARING WITH GREEN TO LIGHT GREEN AT THE TOP, FADING FROM LIGHT YELLOW TO YELLOW IN THE MIDDLE AND FINALLY GRAY AND BLACK AT THE BOTTOM.

FOR CURRY POWDER; FOOD SEASONINGS; SEASONINGS; DRY COMPLETE SEASONING MIXES FOR FISH, MEAT, CHICKEN, OXTAIL, JERK SEASONING; MIXED SPICES FEATURING ALLSPICE, PROCESSED GARLIC, PROCESSED SCALLIONS, AND SEASONING MIXES FOR COCK SOUP (U.S. CL. 46).

LOURDES AYALA, EXAMINING ATTORNEY

SN 85-140,418. PRETTY FLUFFY CHICKEN PRODUCTIONS, LLC, EDINA, MN. FILED 9-28-2010.

**EAT YOUR DRINK**

THE MARK CONSISTS OF STANDARD CHARACTERS WITHOUT CLAIM TO ANY PARTICULAR FONT, STYLE, SIZE, OR COLOR.

NO CLAIM IS MADE TO THE EXCLUSIVE RIGHT TO USE "DRINK", APART FROM THE MARK AS SHOWN.

FOR FLAVORED AND SWEETENED NON-ALCOHOLIC GELATINS; FLAVORED AND SWEETENED NON-ALCOHOLIC GELATIN POWDER TO BE USED FOR MAKING ALCOHOLIC GELATIN SHOOTERS; ICE CREAM; SORBET; BAKERY DESSERTS; ICE CREAM CONTAINING ALCOHOL; SORBET CONTAINING ALCOHOL; BAKERY DESSERTS CONTAINING ALCOHOL; FLAVORED AND SWEETENED GELATIN CONTAINING ALCOHOL (U.S. CL. 46).

WON TEAK OH, EXAMINING ATTORNEY

**CLASS 30—(Continued).**

SN 85-141,092. PERFETTI VAN MELLE BENELUX B.V., BREDA, NETHERLANDS, FILED 9-29-2010.

**Kickin' Lemonade**

THE MARK CONSISTS OF STANDARD CHARACTERS WITHOUT CLAIM TO ANY PARTICULAR FONT, STYLE, SIZE, OR COLOR.

NO CLAIM IS MADE TO THE EXCLUSIVE RIGHT TO USE "LEMONADE", APART FROM THE MARK AS SHOWN.

FOR CONFECTIONERY PRODUCTS, NAMELY, CHEWING GUM, BUBBLE GUM AND CANDIES (U.S. CL. 46).

BRENDAN MCCAULEY, EXAMINING ATTORNEY

SN 85-141,741. PHOENIX INTANGIBLES HOLDING COMPANY, GREENVILLE, DE. FILED 9-30-2010.

**GIANT EAGLE SLENDER SANDWICH BUNS**

THE MARK CONSISTS OF STANDARD CHARACTERS WITHOUT CLAIM TO ANY PARTICULAR FONT, STYLE, SIZE, OR COLOR.

OWNER OF U.S. REG. NOS. 3,140,176, 3,729,689 AND OTHERS.

NO CLAIM IS MADE TO THE EXCLUSIVE RIGHT TO USE "SLENDER SANDWICH BUNS", APART FROM THE MARK AS SHOWN.

FOR BAKERY PRODUCTS (U.S. CL. 46).  
SHAUNIA CARLYLE, EXAMINING ATTORNEY

SN 85-143,653. FIVE ALMONDS, LLC, THE, STAMFORD, CT. FILED 10-1-2010.

**LES CINQ AMANDES**

THE MARK CONSISTS OF STANDARD CHARACTERS WITHOUT CLAIM TO ANY PARTICULAR FONT, STYLE, SIZE, OR COLOR.

NO CLAIM IS MADE TO THE EXCLUSIVE RIGHT TO USE "AMANDES", APART FROM THE MARK AS SHOWN.

THE ENGLISH TRANSLATION OF "LES CINQ AMANDES" IN THE MARK IS "FIVE ALMONDS".

FOR CONFECTIONERIES, NAMELY, CHOCOLATE, CAKES, CHOCOLATE COVERED NUTS, MERINGUES, SUGAR COATED NUTS, CHOCOLATE TRUFFLES, DRAGEES, CARAMELS, HOT CHOCOLATE, COOKIES, MARSHMALLOWS, MARZIPAN AND CANDY MINTS (U.S. CL. 46).

FIRST USE 11-11-2007; IN COMMERCE 11-11-2007.  
STEVEN JACKSON, EXAMINING ATTORNEY

**CLASS 30—(Continued).**

SN 85-145,427. AUNTIE HEATHER'S HOUSE OF BBQ, AKA AHH BBQ, RANCHO CUCAMONGA, CA. FILED 10-5-2010.



NO CLAIM IS MADE TO THE EXCLUSIVE RIGHT TO USE "BBQ", APART FROM THE MARK AS SHOWN.

THE NAME "AUNTIE HEATHER" IDENTIFIES THE PSEUDONYM OF "HEATHER REAVIS", A LIVING INDIVIDUAL WHOSE CONSENT IS OF RECORD.

THE COLOR(S) RED, WHITE, BLUE, YELLOW, GREEN, BROWN, BLACK, GRAY IS/ARE CLAIMED AS A FEATURE OF THE MARK.

THE MARK CONSISTS OF THE DESIGN OF A GRAY SINGLE STORY HOUSE WITH A RED ROOF AND GREEN TRIM WITH BLACK WINDOWS THAT SITS ON GREEN GRASS HILLS NEXT TO A TREE WITH A BROWN TRUNK AND GREEN LEAVES, WITH GREEN BUSHES AND A YELLOW SETTING SUN BEHIND THE HOUSE, ALL BEING SURROUNDED BY A BLUE OVAL BAND WITH TWO YELLOW INTERNAL OVAL LINE ACCENTS ON EDGES, AND A RED RIBBON WITH THE WORDING "AUNTIE HEATHER'S HOUSE OF BBQ!" APPEARING IN WHITE ON THE RIBBON.

FOR BARBECUE DRY RUB; BARBEQUE SAUCE; DRY SPICE RUB FOR MEATS AND FISH; SAUCES; SAUCES FOR BARBECUED MEAT; SPICE RUBS (U.S. CL. 46).

FIRST USE 2-15-2010; IN COMMERCE 3-9-2010.  
CHRISTINE MARTIN, EXAMINING ATTORNEY

SN 85-147,335. LISA LAMME, QUINCY, MA. FILED 10-7-2010.

## Gypsy Juice

THE MARK CONSISTS OF STANDARD CHARACTERS WITHOUT CLAIM TO ANY PARTICULAR FONT, STYLE, SIZE, OR COLOR.

NO CLAIM IS MADE TO THE EXCLUSIVE RIGHT TO USE "JUICE", APART FROM THE MARK AS SHOWN.

FOR BARBECUE SAUCE; BARBEQUE SAUCE; CHICKEN WING SAUCE; CHILI SAUCE; CONDIMENT, NAMELY, PEPPER SAUCE; DIPPING SAUCES; FOOD SEASONINGS; HOT CHILI PEPPER SAUCE; HOT SAUCE; MARINADES; READY-MADE SAUCES; SALAD DRESSINGS; SALAD SAUCES; SAUCES (U.S. CL. 46).

FIRST USE 5-1-1998; IN COMMERCE 6-1-1999.  
WON TEAK OH, EXAMINING ATTORNEY

**CLASS 30—(Continued).**

SN 85-148,538. KERRY O. ASAY, PROVO, UT. FILED 10-8-2010.

## DOHDROPS

THE MARK CONSISTS OF STANDARD CHARACTERS WITHOUT CLAIM TO ANY PARTICULAR FONT, STYLE, SIZE, OR COLOR.

FOR DONUTS; DOUGHNUT HOLES; DOUGHNUTS; FROZEN CONFECTIONS IN THE NATURE OF FROZEN DONUTS AND DONUT DOUGH (U.S. CL. 46).

JEFFREY LOOK, EXAMINING ATTORNEY

SN 85-150,405. SIPPY'S FOODS LLC, ROANOKE, VA. FILED 10-12-2010.



NO CLAIM IS MADE TO THE EXCLUSIVE RIGHT TO USE "SAUCE", APART FROM THE MARK AS SHOWN.

THE NAME "SIPPY" AND THE PORTRAIT IN THE MARK DO NOT IDENTIFY A LIVING INDIVIDUAL.

THE COLOR(S) GOLD, BLACK, WHITE, AND GRAY IS/ARE CLAIMED AS A FEATURE OF THE MARK.

THE MARK CONSISTS OF A BLACK, WHITE AND GRAY PICTURE OF A WOMAN FACING FORWARD, APPEARING WITHIN A GOLD OUTLINED OVAL AND THE STYLIZED WORDING "SIPPY'S SAUCE" IN WHITE AND OUTLINED IN GOLD APPEARING BELOW THE PICTURE.

FOR BARBECUE SAUCE (U.S. CL. 46).  
FIRST USE 9-14-2009; IN COMMERCE 12-15-2009.  
KATHERINE CONNOLLY, EXAMINING ATTORNEY

**CLASS 30—(Continued).**

SN 85-150,535. ADAMS EXTRACT & SPICE LLC, GONZALES, TX. FILED 10-12-2010.



NO CLAIM IS MADE TO THE EXCLUSIVE RIGHT TO USE "CULINARY", APART FROM THE MARK AS SHOWN.

THE MARK CONSISTS OF THE WORD "CULINARY" IN LOWER CAPS ABOVE THE WORD "TONIGHT", CAPITALIZED BELOW A ROUND PLATE WITH A CRESCENT MOON WITH A FORK TO THE LEFT OF THE PLATE, AND A SPOON TO THE RIGHT OF THE PLATE.

FOR SPICES, SPICE RUBS, SEASONING AND MARINADE FOR MEATS, VANILLA, REDUCTIONS EXTRACTS USED AS FLAVORINGS (U.S. CL. 46).

FIRST USE 9-3-2010; IN COMMERCE 9-8-2010.  
GENE MACIOL, EXAMINING ATTORNEY

**CLASS 30—(Continued).**

SN 85-151,811. BLITZ, HOWARD, SUNRISE, FL. FILED 10-13-2010.

**COOL RUBBINGS**

THE MARK CONSISTS OF STANDARD CHARACTERS WITHOUT CLAIM TO ANY PARTICULAR FONT, STYLE, SIZE, OR COLOR.

NO CLAIM IS MADE TO THE EXCLUSIVE RIGHT TO USE "RUBBINGS", APART FROM THE MARK AS SHOWN.

FOR SPICE RUBS; SPICES (U.S. CL. 46).  
FIRST USE 9-1-2010; IN COMMERCE 9-1-2010.  
SALLY SHIH, EXAMINING ATTORNEY

SN 85-153,350. FIELD CANDY COMPANY, L.L.C., MARQUETTE, MI. FILED 10-15-2010.

**FUDGIE PIZZA**

THE MARK CONSISTS OF STANDARD CHARACTERS WITHOUT CLAIM TO ANY PARTICULAR FONT, STYLE, SIZE, OR COLOR.

NO CLAIM IS MADE TO THE EXCLUSIVE RIGHT TO USE "PIZZA", APART FROM THE MARK AS SHOWN.

FOR CANDY (U.S. CL. 46).  
MATTHEW EINSTEIN, EXAMINING ATTORNEY

SN 85-151,058. SPICE PHARM INC., REDWOOD CITY, CA. FILED 10-12-2010.



NO CLAIM IS MADE TO THE EXCLUSIVE RIGHT TO USE "SPICE", APART FROM THE MARK AS SHOWN.

THE MARK CONSISTS OF A STYLIZED LOTUS FLOWER BISECTED BY TEXT IN A CUSTOM FONT REPRESENTING THE COMPANY NAME "SPICE PHARM" IN ALL CAPITALIZED LETTERS.

FOR SPICE BLENDS (U.S. CL. 46).  
FIRST USE 5-20-2010; IN COMMERCE 7-7-2010.  
ALICE BENMAMAN, EXAMINING ATTORNEY

SN 85-154,429. STEVENSON, CHERISE P., BATON ROUGE, LA. AND STEVENSON, ERIC, BATON ROUGE, LA. FILED 10-17-2010.

**CHERISE'S TASTY TANGO  
BATTER MIX**

THE MARK CONSISTS OF STANDARD CHARACTERS WITHOUT CLAIM TO ANY PARTICULAR FONT, STYLE, SIZE, OR COLOR.

NO CLAIM IS MADE TO THE EXCLUSIVE RIGHT TO USE "BATTER MIX", APART FROM THE MARK AS SHOWN.

FOR MIXES FOR MAKING BATTER FOR FRIED FOODS (U.S. CL. 46).  
FIRST USE 9-15-2010; IN COMMERCE 9-15-2010.  
COLLEEN KEARNEY, EXAMINING ATTORNEY

**CLASS 30—(Continued).**

SN 85-154,867. DO-DA INNOVATIONS, LLC, MAIDENS, VA.  
FILED 10-18-2010.

## Ketchup Krayon

THE MARK CONSISTS OF STANDARD CHARACTERS WITHOUT CLAIM TO ANY PARTICULAR FONT, STYLE, SIZE, OR COLOR.

NO CLAIM IS MADE TO THE EXCLUSIVE RIGHT TO USE "KETCHUP", APART FROM THE MARK AS SHOWN. FOR FOOD CONDIMENT CONSISTING PRIMARILY OF KETCHUP AND SALSA; KETCHUP (U.S. CL. 46).  
KEVIN DINALLO, EXAMINING ATTORNEY

SN 85-155,300. PANCRACIO SUCESORES, S.L, CADIZ, SPAIN, FILED 10-18-2010.

## PANCRACIO

THE MARK CONSISTS OF THE STYLIZED WORDING "PANCRACIO".  
THE WORD "PANCRACIO" HAS NO TRANSLATION IN ANY FOREIGN LANGUAGE.

FOR CHOCOLATE; CHOCOLATE TRUFFLES; CHOCOLATE BARS; TEAS; CHOCOLATE-BASED BEVERAGES; TEA-BASED BEVERAGES; CHOCOLATE COVERED CAKES, CHOCOLATE COOKIES, AND CHOCOLATE COVERED FRUITS (U.S. CL. 46).  
FIRST USE 10-6-2010; IN COMMERCE 10-6-2010.  
PAUL F. GAST, EXAMINING ATTORNEY

SN 85-155,315. AMERICAN ROASING COMPANY, LLC, OLDWICK, NJ. FILED 10-18-2010.



NO CLAIM IS MADE TO THE EXCLUSIVE RIGHT TO USE "BLACK RIVER ROASTERS", APART FROM THE MARK AS SHOWN.

THE MARK CONSISTS OF A CLUSTER OF GRASS AND CATTAILS IN A RIVER. BENEATH THE GRASS AND CATTAILS IS THE WORDS "BLACK RIVER" IN ALL CAPITAL LETTERS. BENEATH THESE WORDS IS THE WORD "ROASTERS" CAPITALIZED IN A SMALLER FONT THAN THE WORDS "BLACK RIVER".

FOR COFFEE; COFFEE BEANS; COFFEE PODS; COFFEE-BASED BEVERAGES; GROUND COFFEE BEANS; ROASTED COFFEE BEANS (U.S. CL. 46).  
PAUL F. GAST, EXAMINING ATTORNEY

**CLASS 30—(Continued).**

SN 85-155,445. YOGURT MAMA INC., HILLSBOROUGH, CA. FILED 10-18-2010.

## YOGURT MAMA

THE MARK CONSISTS OF STANDARD CHARACTERS WITHOUT CLAIM TO ANY PARTICULAR FONT, STYLE, SIZE, OR COLOR.

NO CLAIM IS MADE TO THE EXCLUSIVE RIGHT TO USE "YOGURT", APART FROM THE MARK AS SHOWN. FOR FROZEN YOGURT; FROZEN YOGURT MIXES (U.S. CL. 46).  
ROBIN MITTLER, EXAMINING ATTORNEY

SN 85-155,462. YOGURT MAMA INC., HILLSBOROUGH, CA. FILED 10-18-2010.



NO CLAIM IS MADE TO THE EXCLUSIVE RIGHT TO USE "YOGURT", APART FROM THE MARK AS SHOWN.

THE COLOR(S) ORANGE, TEAL, GREEN, PINK, BLACK AND WHITE IS/ARE CLAIMED AS A FEATURE OF THE MARK.

THE MARK CONSISTS OF "YO" AND "MAMA" IN ORANGE WITH WHITE OUTLINE, WITH "GURT" IN TEAL WITH WHITE OUTLINE; THE WORDS "YOGURT MAMA" ARE OUTLINED IN GREEN WITH A GREEN AND WHITE LEAF EXTENDING TO THE RIGHT OF THE WORDS; A PINK AND WHITE FLOWER IS IN THE LOWER LEFT OF THE MARK AND A GIRL'S HEAD IN BLACK AND WHITE WITH PINK TONGUE AND CHEEKS, WEARING A PINK AND WHITE BANDANA, IS IN THE UPPER RIGHT OF THE MARK. THE FLOWER IS OUTLINED IN GREEN AND THE GIRL AND BANDANNA ARE OUTLINED IN BLACK AND GREEN.

FOR FROZEN YOGURT; FROZEN YOGURT MIXES (U.S. CL. 46).  
ROBIN MITTLER, EXAMINING ATTORNEY



**CLASS 30—(Continued).**

SN 85-157,126. STEAK N SHAKE LLC, INDIANAPOLIS, IN. FILED 10-20-2010.

**ROYALE STEAKBURGER**

THE MARK CONSISTS OF STANDARD CHARACTERS WITHOUT CLAIM TO ANY PARTICULAR FONT, STYLE, SIZE, OR COLOR.

NO CLAIM IS MADE TO THE EXCLUSIVE RIGHT TO USE "STEAKBURGER", APART FROM THE MARK AS SHOWN.

FOR SANDWICHES (U.S. CL. 46).  
FIRST USE 9-29-2010; IN COMMERCE 9-29-2010.  
ALICE BENMAMAN, EXAMINING ATTORNEY

SN 85-157,168. H STREET PROPERTIES, LLC, BETHESDA, MD. FILED 10-20-2010.

**H Pizza**

THE MARK CONSISTS OF STANDARD CHARACTERS WITHOUT CLAIM TO ANY PARTICULAR FONT, STYLE, SIZE, OR COLOR.

NO CLAIM IS MADE TO THE EXCLUSIVE RIGHT TO USE "PIZZA", APART FROM THE MARK AS SHOWN.

FOR PIZZAS (U.S. CL. 46).  
JAY FLOWERS, EXAMINING ATTORNEY

SN 85-157,946. SIDMAN, JESSICA, WASHINGTON, DC. FILED 10-21-2010.

**FROZEN FIX**

THE MARK CONSISTS OF STANDARD CHARACTERS WITHOUT CLAIM TO ANY PARTICULAR FONT, STYLE, SIZE, OR COLOR.

NO CLAIM IS MADE TO THE EXCLUSIVE RIGHT TO USE "FROZEN", APART FROM THE MARK AS SHOWN.

FOR FROZEN YOGURT; ICE CREAM; SORBETS (U.S. CL. 46).  
EDWARD NELSON, EXAMINING ATTORNEY

**CLASS 30—(Continued).**

SN 85-158,045. ZUCRUM FOODS, L.L.C., RIO RICO, AZ. FILED 10-21-2010.

**ZULKA  
AUTHENTIC  
CANE SUGAR**

THE MARK CONSISTS OF STANDARD CHARACTERS WITHOUT CLAIM TO ANY PARTICULAR FONT, STYLE, SIZE, OR COLOR.

OWNER OF U.S. REG. NO. 2,281,445.  
NO CLAIM IS MADE TO THE EXCLUSIVE RIGHT TO USE "AUTHENTIC CANE SUGAR", APART FROM THE MARK AS SHOWN.

THE WORD "ZULKA" HAS NO MEANING IN A FOREIGN LANGUAGE.

FOR SUGAR; POWDERED SUGAR (U.S. CL. 46).  
DAVID YONTEF, EXAMINING ATTORNEY

SN 85-158,094. ZUCRUM FOODS, L.L.C., RIO RICO, AZ. FILED 10-21-2010.

**ZULKA  
AUTHENTIC  
POWDERED CANE SUGAR**

THE MARK CONSISTS OF STANDARD CHARACTERS WITHOUT CLAIM TO ANY PARTICULAR FONT, STYLE, SIZE, OR COLOR.

OWNER OF U.S. REG. NO. 2,281,445.  
NO CLAIM IS MADE TO THE EXCLUSIVE RIGHT TO USE "AUTHENTIC POWDERED CANE SUGAR", APART FROM THE MARK AS SHOWN.

THE WORD "ZULKA" HAS NO MEANING IN A FOREIGN LANGUAGE.

FOR SUGAR; POWDERED SUGAR (U.S. CL. 46).  
DAVID YONTEF, EXAMINING ATTORNEY

SN 85-159,259. CHERYL J. ARENDT, OXFORD, CT. FILED 10-22-2010.

**SMARTLY DRESSED IN  
CARAMEL, CHOCOLATE & MORE!**

THE MARK CONSISTS OF STANDARD CHARACTERS WITHOUT CLAIM TO ANY PARTICULAR FONT, STYLE, SIZE, OR COLOR.

NO CLAIM IS MADE TO THE EXCLUSIVE RIGHT TO USE "CARAMEL, CHOCOLATE", APART FROM THE MARK AS SHOWN.

FOR CHOCOLATE COVERED FRUITS; CHOCOLATE COVERED PRETZELS, NUTS AND MARSHMALLOWS; CHOCOLATE CANDIES; CHOCOLATE BARK; CANDIES AND GIFT BASKETS FEATURING CHOCOLATE COVERED FRUITS, CHOCOLATE CANDIES AND CANDIES (U.S. CL. 46).

WILLIAM VERHOSEK, EXAMINING ATTORNEY

**CLASS 30—(Continued).**

SN 85-159,268. CHERYL J. ARENDT, OXFORD, CT. FILED 10-22-2010.

**TOP OF THE CLASS THE  
EDUCATED APPLE**

THE MARK CONSISTS OF STANDARD CHARACTERS WITHOUT CLAIM TO ANY PARTICULAR FONT, STYLE, SIZE, OR COLOR.

NO CLAIM IS MADE TO THE EXCLUSIVE RIGHT TO USE "APPLE", APART FROM THE MARK AS SHOWN.

FOR CHOCOLATE COVERED FRUITS; CHOCOLATE COVERED PRETZELS, NUTS AND MARSHMALLOWS; CHOCOLATE CANDIES; CHOCOLATE BARK; CANDIES AND GIFT BASKETS FEATURING CHOCOLATE COVERED FRUITS, CHOCOLATE CANDIES AND CANDIES (U.S. CL. 46).

WILLIAM VERHOSEK, EXAMINING ATTORNEY

SN 85-160,274. SCHWAN'S IP, LLC, MARSHALL, MN. FILED 10-25-2010.

**AUTHENTIC ASIAN STYLE  
TASTE IN MINUTES**

THE MARK CONSISTS OF STANDARD CHARACTERS WITHOUT CLAIM TO ANY PARTICULAR FONT, STYLE, SIZE, OR COLOR.

NO CLAIM IS MADE TO THE EXCLUSIVE RIGHT TO USE "AUTHENTIC ASIAN STYLE TASTE", APART FROM THE MARK AS SHOWN.

FOR CRAB RANGOONS; POTSTICKERS; WON TONS; EGG ROLLS (U.S. CL. 46).

FIRST USE 9-1-2010; IN COMMERCE 9-1-2010.

PAUL E. FAHRENKOPF, EXAMINING ATTORNEY

SN 85-165,819. ALDI INC., BATAVIA, IL. FILED 11-1-2010.

**KRISP STIX**

THE MARK CONSISTS OF STANDARD CHARACTERS WITHOUT CLAIM TO ANY PARTICULAR FONT, STYLE, SIZE, OR COLOR.

NO CLAIM IS MADE TO THE EXCLUSIVE RIGHT TO USE "STICKS", APART FROM THE MARK AS SHOWN.

FOR CANDY BARS (U.S. CL. 46).

NAAKWAMA ANKRAH, EXAMINING ATTORNEY

**CLASS 30—(Continued).**

SN 85-171,262. NATURE'S SUNSHINE PRODUCTS, INC., PROVO, UT. FILED 11-8-2010.

**SUNVIA**

THE MARK CONSISTS OF STANDARD CHARACTERS WITHOUT CLAIM TO ANY PARTICULAR FONT, STYLE, SIZE, OR COLOR.

FOR SUGAR SUBSTITUTES (U.S. CL. 46).

DAWN HAN, EXAMINING ATTORNEY

SN 85-171,585. ANDRESEN-RYAN COFFEE COMPANY, SUPERIOR, WI. FILED 11-8-2010.

**NORSEMAN GROG**

THE MARK CONSISTS OF STANDARD CHARACTERS WITHOUT CLAIM TO ANY PARTICULAR FONT, STYLE, SIZE, OR COLOR.

NO CLAIM IS MADE TO THE EXCLUSIVE RIGHT TO USE "GROG", APART FROM THE MARK AS SHOWN.

FOR COFFEE (U.S. CL. 46).

FIRST USE 6-0-2006; IN COMMERCE 6-0-2006.

ADA HAN, EXAMINING ATTORNEY

SN 85-172,405. BROOKSIDE FARMS HOMEMADE, CLARKESVILLE, GA. FILED 11-9-2010.

**THOSE ROLLS**

THE MARK CONSISTS OF STANDARD CHARACTERS WITHOUT CLAIM TO ANY PARTICULAR FONT, STYLE, SIZE, OR COLOR.

NO CLAIM IS MADE TO THE EXCLUSIVE RIGHT TO USE "ROLLS", APART FROM THE MARK AS SHOWN.

FOR BAKED GOODS, NAMELY, YEAST DINNER ROLLS (U.S. CL. 46).

FIRST USE 9-1-2009; IN COMMERCE 9-1-2009.

LAURIE MAYES, EXAMINING ATTORNEY

**CLASS 30—(Continued).**

SN 85-173,351. RED DIAMOND, INC., MOODY, AL. FILED 11-10-2010.

**CYBER RIDE WITH**

THE MARK CONSISTS OF STANDARD CHARACTERS WITHOUT CLAIM TO ANY PARTICULAR FONT, STYLE, SIZE, OR COLOR.

OWNER OF U.S. REG. NOS. 636,917, 2,048,250 AND OTHERS.

FOR COFFEE AND TEA (U.S. CL. 46).  
RONALD AIKENS, EXAMINING ATTORNEY

SN 85-173,911. NIPPON PAPER CHEMICALS CO., LTD., CHIYODA-KU, TOKYO, JAPAN, FILED 11-10-2010.

**SK SWEET Z3**

THE MARK CONSISTS OF STANDARD CHARACTERS WITHOUT CLAIM TO ANY PARTICULAR FONT, STYLE, SIZE, OR COLOR.

FOR NATURAL SWEETENERS (U.S. CL. 46).  
CHERYL CLAYTON, EXAMINING ATTORNEY

SN 85-174,261. BETHANY'S BEST, LLC, ATLANTIC HIGHLANDS, NJ. FILED 11-11-2010.

**BRUFFLETTE**

THE MARK CONSISTS OF STANDARD CHARACTERS WITHOUT CLAIM TO ANY PARTICULAR FONT, STYLE, SIZE, OR COLOR.

FOR BAKERY GOODS (U.S. CL. 46).  
PAUL E. FAHRENKOPF, EXAMINING ATTORNEY

**CLASS 30—(Continued).**

SN 85-174,303. TORRECAFE AGUILA ROJA & CIA., S.A., CALI - VALLE, COLOMBIA, FILED 11-11-2010.



OWNER OF U.S. REG. NO. 2,896,207.

THE COLOR(S) RED, WHITE, YELLOW, GOLD AND BLACK IS/ARE CLAIMED AS A FEATURE OF THE MARK.

THE MARK CONSISTS OF A CIRCLE INSIDE OF WHICH APPEARS A PARTIAL VIEW OF A COFFEE CUP FILLED WITH BLACK COFFEE OVER WHICH APPEARS THE WORDING "AGUILA ROJA". THE REMAINING AREA OF THE CUP AND CIRCLE ARE COVERED BY THE DRAWING OF AN EAGLE. THE COLOR YELLOW APPEARS IN THE BACKGROUND INSIDE THE CIRCLE. THE COLOR RED APPEARS IN THE WORDING "AGUILA ROJA" AND IN THE DRAWING OF THE EAGLE. THE COLOR WHITE APPEARS IN THE COFFEE CUP. THE COLOR GOLD APPEARS IN THE THIN RING THAT APPEARS IN THE UPPER BORDER OF THE COFFEE CUP. THE COLOR BLACK APPEARS IN THE OUTER BORDER OF THE CIRCLE.

THE ENGLISH TRANSLATION OF "AGUILA ROJA" IN THE MARK IS "RED EAGLE".

FOR COFFEE (U.S. CL. 46).

FIRST USE 1-1-1992; IN COMMERCE 7-18-2001.

LINDA POWELL, EXAMINING ATTORNEY

SN 85-174,376. CARMI, ELIOT, CITY OF COMMERCE, CA. FILED 11-11-2010.

**THE SIXTH FOOD GROUP**

THE MARK CONSISTS OF STANDARD CHARACTERS WITHOUT CLAIM TO ANY PARTICULAR FONT, STYLE, SIZE, OR COLOR.

NO CLAIM IS MADE TO THE EXCLUSIVE RIGHT TO USE "FOOD GROUP", APART FROM THE MARK AS SHOWN.

FOR FROZEN SOY-BASED DESSERTS; SOY-BASED ICE CREAM SUBSTITUTE (U.S. CL. 46).

ZACHARY BELLO, EXAMINING ATTORNEY

**CLASS 30—(Continued).**

SN 85-175,473. MACNAUGHTON MCPHEE L.L.C., FAIRFIELD, CT. FILED 11-12-2010.

# ROUND OG

THE MARK CONSISTS OF STANDARD CHARACTERS WITHOUT CLAIM TO ANY PARTICULAR FONT, STYLE, SIZE, OR COLOR.

FOR FRANKFURTER SANDWICHES (U.S. CL. 46).  
FIRST USE 5-0-1974; IN COMMERCE 5-0-1974.  
RUDY R. SINGLETON, EXAMINING ATTORNEY

---

SN 85-176,113. BAHOSH, JAMES P., COLUMBUS, NJ. FILED 11-13-2010.

# Death Dust

THE MARK CONSISTS OF STANDARD CHARACTERS WITHOUT CLAIM TO ANY PARTICULAR FONT, STYLE, SIZE, OR COLOR.

FOR EDIBLE SPICES; HOT PEPPER POWDER; PEPPER; PEPPER POWDER; PEPPER SPICE (U.S. CL. 46).  
FIRST USE 10-1-2009; IN COMMERCE 10-1-2009.  
DOUGLAS LEE, EXAMINING ATTORNEY

---

SN 85-176,314. MRS. MADEWELL, LLC, TAMPA, FL. FILED 11-14-2010.

# MRS. MADEWELL

THE MARK CONSISTS OF STANDARD CHARACTERS WITHOUT CLAIM TO ANY PARTICULAR FONT, STYLE, SIZE, OR COLOR.

THE NAME(S), PORTRAIT(S), AND/OR SIGNATURE(S) SHOWN IN THE MARK DOES NOT IDENTIFY A PARTICULAR LIVING INDIVIDUAL.

FOR COOKIES; MUFFINS (U.S. CL. 46).  
FIRST USE 12-0-2009; IN COMMERCE 12-0-2009.  
JESSICA FATHY, EXAMINING ATTORNEY

**CLASS 30—(Continued).**

SN 85-176,743. SUNKIST GROWERS, INC., SHERMAN OAKS, CA. FILED 11-15-2010.



OWNER OF U.S. REG. NOS. 301,278, 3,690,581 AND OTHERS.

FOR GELATO; ICE CREAM; SHERBET; SORBET (U.S. CL. 46).  
REBECCA POVARCHUK, EXAMINING ATTORNEY

---

SN 85-177,255. LEO JOHNSON, INVERMERE, B.C., CANADA, FILED 11-15-2010.

# THREE SISTERS

THE MARK CONSISTS OF STANDARD CHARACTERS WITHOUT CLAIM TO ANY PARTICULAR FONT, STYLE, SIZE, OR COLOR.

FOR (BASED ON USE IN COMMERCE) COFFEE; COFFEE; COFFEE BEANS; GROUND COFFEE BEANS; ROASTED COFFEE BEANS (BASED ON INTENT TO USE) BEVERAGES WITH A COFFEE BASE; COFFEE BASED BEVERAGES (U.S. CL. 46).

FIRST USE 1-31-2000; IN COMMERCE 1-31-2000.  
RENEE MCCRAY, EXAMINING ATTORNEY

---

SN 85-177,453. GENERAL MILLS, INC., MINNEAPOLIS, MN. FILED 11-16-2010.

# BISQUICK...SIMPLY

THE MARK CONSISTS OF STANDARD CHARACTERS WITHOUT CLAIM TO ANY PARTICULAR FONT, STYLE, SIZE, OR COLOR.

OWNER OF U.S. REG. NOS. 289,319, 3,803,146 AND OTHERS.

FOR PANCAKE AND WAFFLE MIXES (U.S. CL. 46).  
PATRICIA EVANKO, EXAMINING ATTORNEY

**CLASS 30—(Continued).**

SN 85-177,481. DAZY'S LLC, BOULDER, CO. FILED 11-16-2010.

**POTSICLES**

THE MARK CONSISTS OF STANDARD CHARACTERS WITHOUT CLAIM TO ANY PARTICULAR FONT, STYLE, SIZE, OR COLOR.

FOR FROZEN CONFECTIONS; FROZEN CONFECTIONS, NAMELY, FREEZER POPS; FROZEN CONFECTIONS, NAMELY, ICES (U.S. CL. 46).

C. DIONNE CLYBURN, EXAMINING ATTORNEY

---

SN 85-177,701. WHOLE FOODS MARKET IP, L.P., AUSTIN, TX. FILED 11-16-2010.

**CONFECTIONIOUS**

THE MARK CONSISTS OF STANDARD CHARACTERS WITHOUT CLAIM TO ANY PARTICULAR FONT, STYLE, SIZE, OR COLOR.

FOR CANDIES, SWEETS, CHOCOLATE AND CHOCOLATES, CHOCOLATE CANDIES, CHOCOLATE COVERED NUTS, CHOCOLATE COVERED PRETZELS, CHOCOLATE COVERED SEEDS, LICORICE, GUMMY CANDIES, YOGURT COVERED NUTS, YOGURT COVERED PRETZELS, YOGURT COVERED SEEDS, CANDY COATED CHOCOLATES (U.S. CL. 46).

INGA ERVIN, EXAMINING ATTORNEY

---

SN 85-178,293. KINETIX LIVING CORP., SEATTLE, WA. FILED 11-16-2010.

**Rebel. Ignite. Commit**

THE MARK CONSISTS OF STANDARD CHARACTERS WITHOUT CLAIM TO ANY PARTICULAR FONT, STYLE, SIZE, OR COLOR.

FOR READY-TO-EAT CEREAL DERIVED FOOD BARS; GRANOLA SNACK BARS; CEREAL-BASED SNACK FOODS; PACKAGED MEALS CONSISTING PRIMARILY OF PASTA OR RICE (U.S. CL. 46).

SANI KHOURI, EXAMINING ATTORNEY

**CLASS 30—(Continued).**

SN 85-178,916. SPICE JUNGLE, LLC, GRAND RAPIDS, MI. FILED 11-17-2010.

**BEANILLA**

THE MARK CONSISTS OF STANDARD CHARACTERS WITHOUT CLAIM TO ANY PARTICULAR FONT, STYLE, SIZE, OR COLOR.

FOR BAKING POWDERS; BAKING SPICES; COFFEE AND TEA; COOKING SALT; EDIBLE SALT; EDIBLE SPICES; EXTRACTS USED AS FLAVORING; FLAVORINGS; FLAVOURINGS; FLAVOURINGS; FOOD FLAVORINGS; SALT; SEA SALT FOR COOKING; SEASONING MIXES; SEASONING PASTES; SEASONINGS; SPICE BLENDS; SPICES; SUGAR AND SUGAR SUBSTITUTES; VANILLA; VANILLA BEANS; VANILLA FLAVORINGS (U.S. CL. 46).

FIRST USE 11-21-2005; IN COMMERCE 2-10-2006.  
JAMES STEIN, EXAMINING ATTORNEY

---

SN 85-179,203. SILVER MINE SUBS FRANCHISE INC., DBA SILVER MINE SUBS, FORT COLLINS, CO. FILED 11-17-2010.

**Buffalo Stampede**

THE MARK CONSISTS OF STANDARD CHARACTERS WITHOUT CLAIM TO ANY PARTICULAR FONT, STYLE, SIZE, OR COLOR.

FOR SANDWICHES, NAMELY, CHICKEN (U.S. CL. 46).

NICHOLAS COLEMAN, EXAMINING ATTORNEY

---

SN 85-179,346. KABUSHIKI KAISHA KURIYAMA BEIKA, ALSO TRADING AS KURIYAMA BEIKA CO., LTD., NIIGATA-KEN, JAPAN, FILED 11-17-2010.

**BAKAUKE**

THE MARK CONSISTS OF STANDARD CHARACTERS WITHOUT CLAIM TO ANY PARTICULAR FONT, STYLE, SIZE, OR COLOR.

THE ENGLISH TRANSLATION OF "BAKAUKE" IN THE MARK IS "VERY CATCHY" OR "EXTREMELY CATCHY".

FOR CRACKERS (U.S. CL. 46).  
FIRST USE 2-9-2001; IN COMMERCE 2-9-2001.  
KATINA MISTER, EXAMINING ATTORNEY

**CLASS 30—(Continued).**

SN 85-179,674. MARTIN'S POTATO CHIPS, INC., THOMASVILLE, PA. FILED 11-18-2010.

# MARTIN'S

THE MARK CONSISTS OF STANDARD CHARACTERS WITHOUT CLAIM TO ANY PARTICULAR FONT, STYLE, SIZE, OR COLOR.

OWNER OF U.S. REG. NOS. 2,838,585 AND 3,100,190. FOR PROCESSED POPCORN (U.S. CL. 46). FIRST USE 6-0-1995; IN COMMERCE 6-0-1995. HOWARD B. LEVINE, EXAMINING ATTORNEY

---

SN 85-181,191. LEO JOHNSON, INVERMERE, B.C., CANADA, FILED 11-19-2010.

# 454 HORSE POWER

THE MARK CONSISTS OF STANDARD CHARACTERS WITHOUT CLAIM TO ANY PARTICULAR FONT, STYLE, SIZE, OR COLOR.

FOR (BASED ON USE IN COMMERCE) COFFEE; COFFEE BEANS; COFFEE-BASED BEVERAGES; GROUND COFFEE BEANS(BASED ON INTENT TO USE) BEVERAGES MADE OF COFFEE; BEVERAGES WITH A COFFEE BASE (U.S. CL. 46). FIRST USE 1-31-1999; IN COMMERCE 1-31-2000. RENEE MCCRAY, EXAMINING ATTORNEY

---

SN 85-193,922. RICH PRODUCTS CORPORATION, BUFFALO, NY. FILED 12-9-2010.

# BLUESBERRY

THE MARK CONSISTS OF STANDARD CHARACTERS WITHOUT CLAIM TO ANY PARTICULAR FONT, STYLE, SIZE, OR COLOR.

FOR READY TO EAT CEREAL DERIVED BREAKFAST BARS (U.S. CL. 46). DOMINIC J. FERRAIUOLO, EXAMINING ATTORNEY

**CLASS 30—(Continued).**

SN 85-194,005. GRUPO BIMBO, S.A. B. DE C.V., MEXICO CITY, MEXICO, FILED 12-9-2010.



THE MARK CONSISTS OF AN IMAGE OF A BAGEL PERSON CARRYING AN UMBRELLA.

FOR BAKERY PRODUCTS (U.S. CL. 46). JEFF DEFORD, EXAMINING ATTORNEY

---

SN 85-194,009. GRUPO BIMBO, S.A. B. DE C.V., MEXICO CITY, MEXICO, FILED 12-9-2010.



THE MARK CONSISTS OF AN OUTLINE OF A PRETZEL SHAKING HANDS WITH A BAGEL.

FOR BAKERY PRODUCTS (U.S. CL. 46). JEFF DEFORD, EXAMINING ATTORNEY

---

SN 85-194,421. LA COLOMBE TORREFACTION, INC., DBA LA COLOMBE, PHILADELPHIA, PA. FILED 12-9-2010.

# Five Degrees

THE MARK CONSISTS OF STANDARD CHARACTERS WITHOUT CLAIM TO ANY PARTICULAR FONT, STYLE, SIZE, OR COLOR.

FOR COFFEE (U.S. CL. 46). FIRST USE 9-1-2010; IN COMMERCE 9-1-2010. MICHELE SWAIN, EXAMINING ATTORNEY

**CLASS 30—(Continued).**

SN 85-200,352. ALANRIC FOOD DISTRIBUTORS, INC., WEST DEPTFORD, NJ. FILED 12-17-2010.

## LA FLORENTINE 1.2.3...CANNOLI

THE MARK CONSISTS OF STANDARD CHARACTERS WITHOUT CLAIM TO ANY PARTICULAR FONT, STYLE, SIZE, OR COLOR.

OWNER OF U.S. REG. NOS. 3,400,688 AND 3,400,689.  
NO CLAIM IS MADE TO THE EXCLUSIVE RIGHT TO USE "CANNOLI", APART FROM THE MARK AS SHOWN. THE ENGLISH TRANSLATION OF LA FLORENTINE IN THE MARK IS THE FLORENTINE.

FOR KITS COMPRISED OF CANNOLI PASTRY SHELLS AND CANNOLI CREAM FOR MAKING BAKERY GOODS, NAMELY, CANNOLI (U.S. CL. 46).  
GRETTA YAO, EXAMINING ATTORNEY

SN 85-200,358. ALANRIC FOOD DISTRIBUTORS, INC., WEST DEPTFORD, NJ. FILED 12-17-2010.

## ANNA 1.2.3...CANNOLI

THE MARK CONSISTS OF STANDARD CHARACTERS WITHOUT CLAIM TO ANY PARTICULAR FONT, STYLE, SIZE, OR COLOR.

OWNER OF U.S. REG. NOS. 3,400,688 AND 3,400,689.  
NO CLAIM IS MADE TO THE EXCLUSIVE RIGHT TO USE "CANNOLI", APART FROM THE MARK AS SHOWN. FOR KITS COMPRISED OF CANNOLI PASTRY SHELLS AND CANNOLI CREAM FOR MAKING BAKERY GOODS, NAMELY, CANNOLI (U.S. CL. 46).  
GRETTA YAO, EXAMINING ATTORNEY

SN 85-206,080. LEASURE, PEARL, MIDDLEBURG, FL. FILED 12-27-2010.

## It's Kickin' Good Candy!

THE MARK CONSISTS OF STANDARD CHARACTERS WITHOUT CLAIM TO ANY PARTICULAR FONT, STYLE, SIZE, OR COLOR.

FOR FOOD, NAMELY, A SNACK CANDY (U.S. CL. 46).  
FIRST USE 4-1-2010; IN COMMERCE 4-1-2010.  
TINA BROWN, EXAMINING ATTORNEY

**CLASS 30—(Continued).**

SN 85-218,357. MAMA ROSA'S LLC, SIDNEY, OH. FILED 1-14-2011.

## BABY MAMA'S

THE MARK CONSISTS OF STANDARD CHARACTERS WITHOUT CLAIM TO ANY PARTICULAR FONT, STYLE, SIZE, OR COLOR.

OWNER OF U.S. REG. NO. 2,409,419.  
FOR PREPARED PIZZA (U.S. CL. 46).  
MARK SPARACINO, EXAMINING ATTORNEY

SN 85-221,088. TOPCO HOLDINGS, INC., SKOKIE, IL. FILED 1-19-2011.

## BELLE TRACKS

THE MARK CONSISTS OF STANDARD CHARACTERS WITHOUT CLAIM TO ANY PARTICULAR FONT, STYLE, SIZE, OR COLOR.

FOR ICE CREAM (U.S. CL. 46).  
TEJBIR SINGH, EXAMINING ATTORNEY

**CLASS 31—NATURAL AGRICULTURAL PRODUCTS**

SN 77-521,872. TRUE VALUE COMPANY, CHICAGO, IL. FILED 7-14-2008.

## GREEN THUMB

THE MARK CONSISTS OF STANDARD CHARACTERS WITHOUT CLAIM TO ANY PARTICULAR FONT, STYLE, SIZE, OR COLOR.

OWNER OF U.S. REG. NOS. 581,301, 3,308,615 AND OTHERS.  
FOR SEEDS AND BULBS (U.S. CLS. 1 AND 46).  
MIDGE BUTLER, EXAMINING ATTORNEY

**CLASS 31—(Continued).**

SN 77-522,562. TRUE VALUE COMPANY, CHICAGO, IL. FILED 7-15-2008.



OWNER OF U.S. REG. NOS. 581,301, 3,308,615 AND OTHERS.

THE MARK CONSISTS OF THE WORDS "GREEN THUMB" UNDERLINED BY A CURVED LINE, IN A MISCELLANEOUS OVAL DESIGN WITH A LEAF DESIGN TO THE RIGHT OF THE WORDS "GREEN THUMB". FOR SEEDS AND BULBS (U.S. CLS. 1 AND 46). MIDGE BUTLER, EXAMINING ATTORNEY

SN 77-921,203. CAPUCILLI, ALYSSA S., NEW YORK, NY. AND SCHORIES, PAT, NEW YORK, NY. FILED 1-27-2010.



OWNER OF U.S. REG. NO. 3,844,698. NO CLAIM IS MADE TO THE EXCLUSIVE RIGHT TO USE "BISCUIT", APART FROM THE MARK AS SHOWN.

THE MARK CONSISTS OF THE LITERAL ELEMENTS "BISCUIT" AND "THE LITTLE YELLOW PUPPY" IN STYLIZED LETTERING, A CIRCULAR RING, AND A FANCIFUL REPRESENTATION OF A PUPPY. THE WORD "BISCUIT" APPEARS IN THE TOP OF THE RING AND THE WORDS "THE LITTLE YELLOW PUPPY" APPEAR ALONG THE BOTTOM OF THE RING. AT THE CENTER OF THE RING IS A FANCIFUL REPRESENTATION OF A PUPPY.

FOR PET FOOD AND PET TREATS (U.S. CLS. 1 AND 46).

JOHN SCHUYLER YARD, EXAMINING ATTORNEY

**CLASS 31—(Continued).**

SN 77-929,462. LATTIG, MICHAEL D., DBA CLEARWATER NATIVE NURSERY, REDMOND, OR. FILED 2-5-2010.

CLEARWATER NATIVE PLANT  
NURSERY

THE MARK CONSISTS OF STANDARD CHARACTERS WITHOUT CLAIM TO ANY PARTICULAR FONT, STYLE, SIZE, OR COLOR.

NO CLAIM IS MADE TO THE EXCLUSIVE RIGHT TO USE "NATIVE PLANT NURSERY", APART FROM THE MARK AS SHOWN.

FOR LIVE SHRUBS; LIVE TREES; NATURAL PLANTS AND FLOWERS (U.S. CLS. 1 AND 46).

ROBERT STRUCK, EXAMINING ATTORNEY

SN 79-083,344. SPECIALES GILLARDEAU, FRANCE, FILED 5-12-2010.

# GILLARDEAU

THE MARK CONSISTS OF STANDARD CHARACTERS WITHOUT CLAIM TO ANY PARTICULAR FONT, STYLE, SIZE, OR COLOR.

PRIORITY DATE OF 11-18-2009 IS CLAIMED.

OWNER OF INTERNATIONAL REGISTRATION 1040888 DATED 5-12-2010, EXPIRES 5-12-2020.

THE WORDING "GILLARDEAU" HAS NO MEANING IN A FOREIGN LANGUAGE.

FOR LIVE SHELLFISH, NAMELY, OYSTERS (U.S. CLS. 1 AND 46).

CHARISMA HAMPTON, EXAMINING ATTORNEY

SN 79-083,853. VALFRUTTA FRESCO S.P.A. CONSORTILE, ITALY, FILED 5-26-2010.



PRIORITY DATE OF 4-13-2010 IS CLAIMED.

OWNER OF INTERNATIONAL REGISTRATION 1042326 DATED 5-26-2010, EXPIRES 5-26-2020.

NO CLAIM IS MADE TO THE EXCLUSIVE RIGHT TO USE "COOPERATIVE AGRICOLE", APART FROM THE MARK AS SHOWN.

THE COLOR(S) WHITE, GREEN AND RED IS/ARE CLAIMED AS A FEATURE OF THE MARK.

THE MARK CONSISTS OF THE WORDING "VALFRUTTA" IN WHITE STYLIZED CHARACTERS, BELOW WHICH APPEARS THE SMALLER SIZED WORDING "COOPERATIVE AGRICOLE" IN WHITE STYLIZED CHARACTERS; ALL OF THIS WORDING APPEARS IN A STYLIZED DESIGN OF A GREEN LEAF, WITH THE RED LINE REPRESENTING PART OF THE LOWER RIGHT PART OF THE LEAF, SLIGHTLY SEPARATED FROM THE GREEN PORTION OF THE LEAF.

THE ENGLISH TRANSLATION OF "COOPERATIVE AGRICOLE" IN THE MARK IS "AGRICULTURAL COOPERATIVE".

FOR FRESH FRUITS AND VEGETABLES (U.S. CLS. 1 AND 46).

JAMES MACFARLANE, EXAMINING ATTORNEY



**CLASS 31—(Continued).**

SN 79-084,236. MINISTERO DELLE POLITICHE AGRICOLE.; ALIMENTARI E FORESTALI -; DIPARTIMENTO DELLE POLITICHE; COMPETITIVE DEL MONDO RURALE; E DELLA QUALITA' -; DIREZIONE GENERALE PER LO SVILUPPO AGROALIMENTARE.; LA QUALITA' E LA TUTELA; DEL CONSUMATORE, ITALY, FILED 4-21-2010.

**NOCCIOLA DI GIFFONI**

THE MARK CONSISTS OF STANDARD CHARACTERS WITHOUT CLAIM TO ANY PARTICULAR FONT, STYLE, SIZE, OR COLOR.

PRIORITY DATE OF 2-10-2010 IS CLAIMED.

OWNER OF INTERNATIONAL REGISTRATION 1043255 DATED 4-21-2010, EXPIRES 4-21-2020.

NO CLAIM IS MADE TO THE EXCLUSIVE RIGHT TO USE "NOCCIOLA", APART FROM THE MARK AS SHOWN. THE ENGLISH TRANSLATION OF "NOCCIOLA DI GIFFONI" IN THE MARK IS "HAZELNUT OF GIFFONI".

THE CERTIFICATION MARK, AS INTENDED TO BE USED BY PERSONS AUTHORIZED BY THE CERTIFIER, IS INTENDED TO CERTIFY THAT THE GOODS PROVIDED ORIGINATE IN THE COMMUNES OF GIFFONI VALLE PIANA, GIFFONI SEI CASALI, SAN CIPRIANO PICENTINO, FISCIANO, CALVANCIO, CASTIGLIONE DEI GENOVESI, MONTECORVINO ROVELLA, AND IN PART THE COMMUNES OF BARONISSI, MONTECORVINO PUGLIANO, OLEVANO SUL TUSCIANO, SAN MANGO PIEMONTE AND ACERNO IN ITALY, AND THAT THE PREPARATION, PRODUCTION, AND/OR PROCESSING OF THE GOODS TAKE PLACE ACCORDING TO THE STANDARD OF RECORD.

FOR UNPROCESSED HAZELNUTS (U.S. CLS. 1 AND 46).

MARK RADEMACHER, EXAMINING ATTORNEY

**CLASS 31—(Continued).**

SN 79-084,238. MINISTERO DELLE POLITICHE AGRICOLE.; ALIMENTARI E FORESTALI -; DIPARTIMENTO DELLE POLITICHE; COMPETITIVE DEL MONDO RURALE; E DELLA QUALITA' -; DIREZIONE GENERALE PER LO SVILUPPO AGROALIMENTARE.; LA QUALITA' E LA TUTELA; DEL CONSUMATORE, ITALY, FILED 4-21-2010.

**PESCA E NETTARINA DI ROMAGNA**

THE MARK CONSISTS OF STANDARD CHARACTERS WITHOUT CLAIM TO ANY PARTICULAR FONT, STYLE, SIZE, OR COLOR.

PRIORITY DATE OF 2-10-2010 IS CLAIMED.

OWNER OF INTERNATIONAL REGISTRATION 1043257 DATED 4-21-2010, EXPIRES 4-21-2020.

NO CLAIM IS MADE TO THE EXCLUSIVE RIGHT TO USE "PESCA E NETTARINA", APART FROM THE MARK AS SHOWN.

THE ENGLISH TRANSLATION OF "PESCA E NETTARINA DI ROMAGNA" IN THE MARK IS "PEACH AND NECTARINE OF ROMAGNA".

THE CERTIFICATION MARK, AS INTENDED TO BE USED BY PERSONS AUTHORIZED BY THE CERTIFIER, IS INTENDED TO CERTIFY THAT THE GOODS PROVIDED ORIGINATE IN THE PART OF EMILIA ROMAGNA SUITABLE FOR THE CULTIVATION OF PEACHES AND NECTARINES IN ITALY, AND THAT THE PREPARATION, PRODUCTION, AND/OR PROCESSING OF THE GOODS TAKE PLACE ACCORDING TO THE STANDARD OF RECORD.

FOR FRESH PEACHES (U.S. CLS. 1 AND 46).

MARK RADEMACHER, EXAMINING ATTORNEY

SN 79-084,237. MINISTERO DELLE POLITICHE AGRICOLE.; ALIMENTARI E FORESTALI -; DIPARTIMENTO DELLE POLITICHE; COMPETITIVE DEL MONDO RURALE; E DELLA QUALITA' -; DIREZIONE GENERALE PER LO SVILUPPO AGROALIMENTARE.; LA QUALITA' E LA TUTELA; DEL CONSUMATORE, ITALY, FILED 4-19-2010.

**MARRONE DI SAN ZENO**

THE MARK CONSISTS OF STANDARD CHARACTERS WITHOUT CLAIM TO ANY PARTICULAR FONT, STYLE, SIZE, OR COLOR.

PRIORITY DATE OF 2-10-2010 IS CLAIMED.

OWNER OF INTERNATIONAL REGISTRATION 1043256 DATED 4-19-2010, EXPIRES 4-19-2020.

NO CLAIM IS MADE TO THE EXCLUSIVE RIGHT TO USE "MARRONE", APART FROM THE MARK AS SHOWN.

THE ENGLISH TRANSLATION OF "MARRONE DI SAN ZENO" IN THE MARK IS "CHESTNUT OF SAN ZENO".

THE CERTIFICATION MARK, AS INTENDED TO BE USED BY PERSONS AUTHORIZED BY THE CERTIFIER, IS INTENDED TO CERTIFY THAT THE GOODS PROVIDED ORIGINATE BETWEEN 250 AND 900 METERS ABOVE SEA LEVEL IN THE TERRITORY OF MONTE BALDO, I.E. BETWEEN LAKE GARDA AND THE ADIGE RIVER VALLEY. IT COMPRISES PARTS OF THE FOLLOWING MUNICIPALITIES: BRENTINO-BELLUNO, BRENZONE, CAPRINO VERONESE, COSTERMANO, FERRARA DI MONTE BALDO AND SAN ZENO DI MONTAGNA, ALL OF WHICH ARE IN THE HOMOGENEOUS MONTE BALDO MOUNTAIN COMMUNITY AREA IN ITALY, AND THAT THE PREPARATION, PRODUCTION, AND/OR PROCESSING OF THE GOODS TAKE PLACE ACCORDING TO THE STANDARD OF RECORD.

FOR FRESH CHESTNUTS (U.S. CLS. 1 AND 46).

MARK RADEMACHER, EXAMINING ATTORNEY

SN 79-084,250. MINISTERO DELLE POLITICHE AGRICOLE.; ALIMENTARI E FORESTALI -; DIPARTIMENTO DELLE POLITICHE; COMPETITIVE DEL MONDO RURALE; E DELLA QUALITA' -; DIREZIONE GENERALE PER LO SVILUPPO AGROALIMENTARE.; LA QUALITA' E LA TUTELA; DEL CONSUMATORE, ITALY, FILED 4-16-2010.

**CILIEGIA DI MAROSTICA**

THE MARK CONSISTS OF STANDARD CHARACTERS WITHOUT CLAIM TO ANY PARTICULAR FONT, STYLE, SIZE, OR COLOR.

PRIORITY DATE OF 2-8-2010 IS CLAIMED.

OWNER OF INTERNATIONAL REGISTRATION 1043269 DATED 4-16-2010, EXPIRES 4-16-2020.

NO CLAIM IS MADE TO THE EXCLUSIVE RIGHT TO USE "CILIEGIA", APART FROM THE MARK AS SHOWN.

THE ENGLISH TRANSLATION OF "CILIEGIA DI MAROSTICA" IN THE MARK IS "CHERRY OF MAROSTICA".

THE CERTIFICATION MARK, AS INTENDED TO BE USED BY PERSONS AUTHORIZED BY THE CERTIFIER, IS INTENDED TO CERTIFY THAT THE GOODS PROVIDED ORIGINATE IN NINE MUNICIPALITIES, INCLUDING THE MUNICIPALITY OF MAROSTICA, IN THE PROVINCE OF VICENZA IN ITALY, AND THAT THE PREPARATION, PRODUCTION, AND/OR PROCESSING OF THE GOODS TAKE PLACE ACCORDING TO THE STANDARD OF RECORD.

FOR FRESH CHERRIES (U.S. CLS. 1 AND 46).

MARK RADEMACHER, EXAMINING ATTORNEY

**CLASS 31—(Continued).**

SN 79-084,252. MINISTERO DELLE POLITICHE AGRICOLE.; ALIMENTARI E FORESTALI -; DIPARTIMENTO DELLE POLITICHE; COMPETITIVE DEL MONDO RURALE; E DELLA QUALITA' -; DIREZIONE GENERALE PER LO SVILUPPO AGROALIMENTARE.; LA QUALITA' E LA TUTELA; DEL CONSUMATORE, ITALY, FILED 4-16-2010.

## CLEMENTINE DEL GOLFO DI TARANTO

THE MARK CONSISTS OF STANDARD CHARACTERS WITHOUT CLAIM TO ANY PARTICULAR FONT, STYLE, SIZE, OR COLOR.

PRIORITY DATE OF 2-8-2010 IS CLAIMED.

OWNER OF INTERNATIONAL REGISTRATION 1043271 DATED 4-16-2010, EXPIRES 4-16-2020.

NO CLAIM IS MADE TO THE EXCLUSIVE RIGHT TO USE "CLEMENTINE", APART FROM THE MARK AS SHOWN.

THE ENGLISH TRANSLATION OF "CLEMENTINE DEL GOLFO DI TARANTO" IN THE MARK IS "CLEMENTINES OF THE GULF OF TARANTO".

THE CERTIFICATION MARK, AS INTENDED TO BE USED BY PERSONS AUTHORIZED BY THE CERTIFIER, IS INTENDED TO CERTIFY THAT THE GOODS PROVIDED ORIGINATE IN THE PROVINCE OF TARANTO IN THE APULIA REGION AND COMPRISES THE MUNICIPALITIES OF PALAGIANO, MASSAFRA, GINOSA, CASTELLANETA, PALAGIANELLO, TARANTO AND STATTE IN ITALY, AND THAT THE PREPARATION, PRODUCTION, AND/OR PROCESSING OF THE GOODS TAKE PLACE ACCORDING TO THE STANDARD OF RECORD.

FOR FRESH CLEMENTINE MANDARINS (U.S. CLS. 1 AND 46).

MARK RADEMACHER, EXAMINING ATTORNEY

**CLASS 31—(Continued).**

SN 85-040,408. C.I. BANACOL, S.A., MEDELLIN, COLOMBIA, FILED 5-17-2010.



OWNER OF U.S. REG. NO. 1,663,564.

NO CLAIM IS MADE TO THE EXCLUSIVE RIGHT TO USE "BANANAS", APART FROM THE MARK AS SHOWN. THE COLOR(S) HUNTER GREEN AND RASPBERRY RED IS/ARE CLAIMED AS A FEATURE OF THE MARK.

THE MARK CONSISTS OF A NUMBER ONE IN RASPBERRY RED, FOLLOWED BY AN UPPER-CASE LETTER "A" IN HUNTER GREEN AND HAVING A LEAF IN HUNTER GREEN AS THE CROSS-BAR IN THE LETTER "A", FOLLOWED BY A NUMBER ONE IN RASPBERRY RED, ABOVE THE WORD "BANANAS" IN UPPER-CASE LETTERS IN HUNTER GREEN.

FOR FRESH BANANAS (U.S. CLS. 1 AND 46).

FIRST USE 10-10-2009; IN COMMERCE 10-10-2009.

HENRY S. ZAK, EXAMINING ATTORNEY

SN 85-105,774. BUCKLEY FARMS NAZCAFLOR, INC., MIAMI, FL. FILED 8-12-2010.

SN 79-085,853. MARKUS OLBERTS, FED REP GERMANY, FILED 7-3-2010.

## LUPO

THE MARK CONSISTS OF STANDARD CHARACTERS WITHOUT CLAIM TO ANY PARTICULAR FONT, STYLE, SIZE, OR COLOR.

OWNER OF INTERNATIONAL REGISTRATION 1037782 DATED 4-14-2010, EXPIRES 4-14-2020.

THE ENGLISH TRANSLATION OF "LUPO" IN THE MARK IS "WOLF".

FOR ANIMAL FOODSTUFFS (U.S. CLS. 1 AND 46).

KAREN BRACEY, EXAMINING ATTORNEY



NO CLAIM IS MADE TO THE EXCLUSIVE RIGHT TO USE "FLOR", APART FROM THE MARK AS SHOWN.

THE COLOR(S) BLUE AND ORANGE IS/ARE CLAIMED AS A FEATURE OF THE MARK.

THE MARK CONSISTS OF THE STYLIZED WORDING "NAZCA FLOR" IN BLUE WITH AN ORANGE WAVY LINE STARTING BELOW THE WORDING "NAZCA" AND ENDING AFTER THE WORDING "FLOR".

THE ENGLISH TRANSLATION OF THE WORD "FLOR" IN THE MARK IS "FLOWER".

FOR CUT FLOWERS (U.S. CLS. 1 AND 46).

FIRST USE 1-1-2003; IN COMMERCE 1-1-2003.

DOMINIC J. FERRAIUOLO, EXAMINING ATTORNEY

**CLASS 31—(Continued).**

SN 85-124,677. SOCIETE DES PRODUITS NESTLE S.A., VEVEY, SWITZERLAND, FILED 9-8-2010.

**BAKED DELIGHTS**

THE MARK CONSISTS OF STANDARD CHARACTERS WITHOUT CLAIM TO ANY PARTICULAR FONT, STYLE, SIZE, OR COLOR.

NO CLAIM IS MADE TO THE EXCLUSIVE RIGHT TO USE "BAKED", APART FROM THE MARK AS SHOWN.

FOR PET FOOD (U.S. CLS. 1 AND 46).  
PAUL MORENO, EXAMINING ATTORNEY

**CLASS 31—(Continued).**

SN 85-127,797. POTANDON PRODUCE L.L.C., IDAHO FALLS, ID. FILED 9-13-2010.



OWNER OF U.S. REG. NOS. 615,933 AND 1,265,208.  
THE COLOR(S) GREEN, LIGHT, MEDIUM, AND DARK YELLOW, LIGHT AND MEDIUM PURPLE, LIGHT BLUE, BLACK, WHITE AND GRAY IS/ARE CLAIMED AS A FEATURE OF THE MARK.

THE MARK CONSISTS OF THE WORD "SUNFRESH" IN BLACK WITH A WHITE AND GRAY OUTLINE BENEATH A COUNTRY SCENE SHOWING PLANTED AND UNPLANTED GREEN FIELDS AND TREES IN THE FOREGROUND WITH A BLUE AND PURPLE-SHADED MOUNTAIN RANGE IN THE BACKGROUND WITH A YELLOW-SHADED SUN RISING BEHIND IT.

FOR FRESH VEGETABLES (U.S. CLS. 1 AND 46).  
FIRST USE 10-31-2009; IN COMMERCE 10-31-2009.  
HOWARD SMIGA, EXAMINING ATTORNEY

SN 85-138,319. ANGEL ACRES ORGANICS, LLC, NAPA, CA. FILED 9-25-2010.

SN 85-126,135. KIMBERLY S HINKLE, DBA HARVEST FRESH FARM, DESHA, AR. AND STANLEY G HINKLE, DBA HARVEST FRESH FARM, DESHA, AR. FILED 9-9-2010.

**Harvest Fresh Farm**



NO CLAIM IS MADE TO THE EXCLUSIVE RIGHT TO USE "VINEYARD", APART FROM THE MARK AS SHOWN.

THE COLOR(S) BLUE, BROWN, RED AND BLACK IS/ARE CLAIMED AS A FEATURE OF THE MARK.

THE MARK CONSISTS OF A BLUE, RED, BROWN AND BLACK SQUIRREL HOLDING AN ACORN BENEATH WHICH APPEAR THE WORDS CZERWONA WIEWIORKA AND RED SQUIRREL IN RED, SEPARATED BY A BROWN ACORN, BENEATH WHICH APPEAR THE STYLIZED WORDS ANGEL ACRES VINEYARD IN BROWN, OUTLINED IN RED.

THE ENGLISH TRANSLATION OF CZERWONA WIEWIORKA IN THE MARK IS RED SQUIRREL.

THE MARK CONSISTS OF STANDARD CHARACTERS WITHOUT CLAIM TO ANY PARTICULAR FONT, STYLE, SIZE, OR COLOR.

NO CLAIM IS MADE TO THE EXCLUSIVE RIGHT TO USE "FRESH FARM", APART FROM THE MARK AS SHOWN.

FOR FRESH CULINARY HERBS (U.S. CLS. 1 AND 46).  
FIRST USE 8-17-2008; IN COMMERCE 8-17-2008.  
NICHOLAS ALTREE, EXAMINING ATTORNEY

FOR FRESH WINE GRAPES (U.S. CLS. 1 AND 46).  
FIRST USE 9-23-2010; IN COMMERCE 9-23-2010.  
JOHN DALIER, EXAMINING ATTORNEY

**CLASS 31—(Continued).**

SN 85-140,016. HALO, PURELY FOR PETS, INC., TAMPA, FL. FILED 9-28-2010.

**SPOT'S CHEW**

THE MARK CONSISTS OF STANDARD CHARACTERS WITHOUT CLAIM TO ANY PARTICULAR FONT, STYLE, SIZE, OR COLOR.

OWNER OF U.S. REG. NOS. 2,216,548, 3,432,271 AND 3,446,096.

NO CLAIM IS MADE TO THE EXCLUSIVE RIGHT TO USE "CHEW", APART FROM THE MARK AS SHOWN.

FOR PET TREATS (U.S. CLS. 1 AND 46).

FIRST USE 8-20-2010; IN COMMERCE 8-20-2010.

REBECCA EISINGER, EXAMINING ATTORNEY

**CLASS 31—(Continued).**

SN 85-154,600. PERENNIAL FAVORITES LLC, LAYTON, UT. FILED 10-18-2010.

**PERENNIAL FAVORITES**

THE MARK CONSISTS OF STANDARD CHARACTERS WITHOUT CLAIM TO ANY PARTICULAR FONT, STYLE, SIZE, OR COLOR.

NO CLAIM IS MADE TO THE EXCLUSIVE RIGHT TO USE "PERENNIAL", APART FROM THE MARK AS SHOWN.

FOR LIVE PLANTS, NAMELY, PERENNIAL FLOWERS AND PLANTS, FLOWERING SHRUBS, NATIVE PLANTS TO THE ROCKY MOUNTAINS, ANNUAL FLOWERS AND PLANTS, VEGETABLE PLANTS, AND HERB PLANTS (U.S. CLS. 1 AND 46).

FIRST USE 1-1-1993; IN COMMERCE 9-8-2004.

JAMES LOVELACE, EXAMINING ATTORNEY

SN 85-150,310. 1329729 ONTARIO INC., LEAMINGTON, ONTARIO, CANADA, FILED 10-12-2010.



OWNER OF U.S. REG. NO. 3,813,951.

THE MARK CONSISTS OF "TOPLINE" WITH LARGE CAPITALS "T" AND "L" AND SMALL CAPITALS FOR THE OTHER LETTERS, ALL IN AN OVAL SHAPE. THE LETTERS HAVE A BORDER AND A SHADOW ON THE LOWER AND RIGHT SIDES. BELOW THE LETTERS ARE SIX HORIZONTAL BARS WITH WAVES ON THE RIGHT SIDE ON THE BOTTOM FIVE BARS. SIX BARS EXTEND ACROSS THE OVAL ABOVE THE LETTERS WITH CLOUDS ON THE RIGHT EXCEPT FOR THE BOTTOM TWO BARS WHICH ARE MOSTLY HIDDEN BY THE LETTERS.

FOR FRESH FRUITS AND VEGETABLES (U.S. CLS. 1 AND 46).

FIRST USE 5-0-1999; IN COMMERCE 5-0-1999.

ANDREA K. NADELMAN, EXAMINING ATTORNEY

SN 85-155,549. WHITE OAK GOLDEN RETRIEVERS, DBA PERFECT ENTERPRISES INC., LINDSIDE, WV. FILED 10-18-2010.



WHITE OAK GOLDEN RETRIEVERS

NO CLAIM IS MADE TO THE EXCLUSIVE RIGHT TO USE "GOLDEN RETRIEVERS" AND THE REPRESENTATION OF A DOG, APART FROM THE MARK AS SHOWN.

THE MARK CONSISTS OF THE WORDING "WHITE OAK GOLDEN RETRIEVERS" BELOW A SILHOUETTES OF A DOG.

FOR DOGS (U.S. CLS. 1 AND 46).

BILL DAWE, EXAMINING ATTORNEY

**CLASS 31—(Continued).**

SN 85-158,058. DIESTE, ROBERT ANTHONY, DALLAS, TX. FILED 10-21-2010.

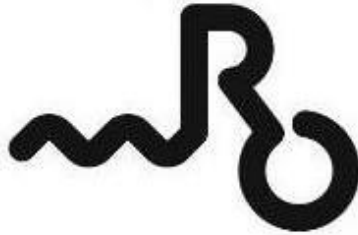

THE MARK CONSISTS OF A STYLIZED LETTER "R" WITH THE LETTER "O" CONNECTED AND A HORIZONTAL ZIG-ZAG LINE EXTENDING FROM THE LEFT SIDE OF THE "R".

FOR LIVESTOCK, NAMELY, CATTLE; HAY (U.S. CLS. 1 AND 46).  
FIRST USE 1-0-2009; IN COMMERCE 1-0-2009.  
LINDSEY RUBIN, EXAMINING ATTORNEY

**CLASS 31—(Continued).**

SN 85-175,233. KENT NUTRITION GROUP, INC., MUSCATINE, IA. FILED 11-12-2010.

Stoney Creek

THE MARK CONSISTS OF STANDARD CHARACTERS WITHOUT CLAIM TO ANY PARTICULAR FONT, STYLE, SIZE, OR COLOR.

FOR PET FOODS, BIRD FOOD, AND FOOD FOR SMALL ANIMALS (U.S. CLS. 1 AND 46).  
DAWN HAN, EXAMINING ATTORNEY

SN 85-176,428. STAM, LLC, PORTLAND, OR. FILED 11-15-2010.

real food, not junk food

ENERGYFIT

THE MARK CONSISTS OF STANDARD CHARACTERS WITHOUT CLAIM TO ANY PARTICULAR FONT, STYLE, SIZE, OR COLOR.

FOR PET FOODS (U.S. CLS. 1 AND 46).  
DAWN HAN, EXAMINING ATTORNEY

THE MARK CONSISTS OF STANDARD CHARACTERS WITHOUT CLAIM TO ANY PARTICULAR FONT, STYLE, SIZE, OR COLOR.

FOR DOG TREATS (U.S. CLS. 1 AND 46).  
FIRST USE 2-1-2008; IN COMMERCE 2-1-2008.  
JOHN DALIER, EXAMINING ATTORNEY

SN 85-176,552. STAM, LLC, PORTLAND, OR. FILED 11-15-2010.

because dogs can't read labels

IMPROVING NATURE'S GRAINS

THE MARK CONSISTS OF STANDARD CHARACTERS WITHOUT CLAIM TO ANY PARTICULAR FONT, STYLE, SIZE, OR COLOR.

FOR AGRICULTURAL SEEDS (U.S. CLS. 1 AND 46).  
FIRST USE 12-31-2005; IN COMMERCE 12-31-2005.  
MARK T. MULLEN, EXAMINING ATTORNEY

THE MARK CONSISTS OF STANDARD CHARACTERS WITHOUT CLAIM TO ANY PARTICULAR FONT, STYLE, SIZE, OR COLOR.

FOR DOG TREATS (U.S. CLS. 1 AND 46).  
FIRST USE 9-13-2009; IN COMMERCE 9-13-2009.  
JOHN DALIER, EXAMINING ATTORNEY

**CLASS 31—(Continued).**

SN 85-180,419. SPEROS ENTERPRISES INC., PHOENIX, AZ.  
FILED 11-18-2010.

**TopDog TidBits**

THE MARK CONSISTS OF STANDARD CHARACTERS WITHOUT CLAIM TO ANY PARTICULAR FONT, STYLE, SIZE, OR COLOR.

FOR PET TREATS (U.S. CLS. 1 AND 46).  
FIRST USE 10-18-2010; IN COMMERCE 10-18-2010.  
KEVON CHISOLM, EXAMINING ATTORNEY

**CLASS 31—(Continued).**

SN 85-210,636. WINFIELD SOLUTIONS, LLC, SHOREVIEW, MN. FILED 1-5-2011.

**GUNNER**

THE MARK CONSISTS OF STANDARD CHARACTERS WITHOUT CLAIM TO ANY PARTICULAR FONT, STYLE, SIZE, OR COLOR.

FOR SEEDS FOR AGRICULTURAL PURPOSES (U.S. CLS. 1 AND 46).  
LINDA MICKLEBURGH, EXAMINING ATTORNEY

SN 85-181,027. LEAP MEDIA GROUP, INC., ANDERSON, IN.  
FILED 11-19-2010.



THE COLOR(S) WHITE, RED AND BROWN IS/ARE CLAIMED AS A FEATURE OF THE MARK.

THE MARK CONSISTS OF THE TEXT SCOUT & ZOE'S IN WHITE LETTERING BELOW A WHITE PAW PRINT. THE PAW PRINT AND AMPERSAND ARE ON A RECTANGULAR, RED BACKGROUND, WHILE THE OTHER TEXT IS ON A BROWN BACKGROUND.

FOR CONSUMABLE PET CHEWS (U.S. CLS. 1 AND 46).

FIRST USE 6-11-2010; IN COMMERCE 10-1-2010.  
MIDGE BUTLER, EXAMINING ATTORNEY

**CLASS 32—LIGHT BEVERAGES**

SN 77-406,878. ATTUNE FOODS, INC., SAN FRANCISCO, CA. FILED 2-26-2008.



OWNER OF U.S. REG. NOS. 3,287,144 AND 3,336,806.

THE COLOR(S) RED, ORANGE, BLUE, GREEN AND PURPLE IS/ARE CLAIMED AS A FEATURE OF THE MARK.

THE MARK CONSISTS OF THE WORD "ATTUNE" WITH THE LETTER "A" IN RED, THE LETTERS "T" IN ORANGE, THE LETTER "U" IN BLUE, THE LETTER "N" IN GREEN, AND THE LETTER "E" IN PURPLE.

FOR CONCENTRATES, SYRUPS OR POWDERS USED IN THE PREPARATION OF SOFT DRINKS (U.S. CLS. 45, 46 AND 48).

MICHAEL WIENER, EXAMINING ATTORNEY

SN 85-186,594. CRANE, DAVID, D., DBA DOGGIE BEER BONES, SAN DIEGO, CA. FILED 11-29-2010.



NO CLAIM IS MADE TO THE EXCLUSIVE RIGHT TO USE "BONES", APART FROM THE MARK AS SHOWN.

THE MARK CONSISTS OF THE TERMS, "DOGGIE BEER BONES", TO THE RIGHT OF THE DESIGN OF A DOG FACE WITH HIS TONGUE STICKING OUT AND A BONE FILLED WITH BEER AND FOAM ON TOP BALANCED ON HIS NOSE.

FOR DIGESTIBLE CHEWING BONES FOR DOGS (U.S. CLS. 1 AND 46).

FIRST USE 6-1-2010; IN COMMERCE 6-1-2010.  
BARBARA A. GOLD, EXAMINING ATTORNEY

SN 77-875,777. SONU BEVERAGES LLC, NEW YORK, NY.  
FILED 11-18-2009.

**ORGANICALLY REFRESHING**

THE MARK CONSISTS OF STANDARD CHARACTERS WITHOUT CLAIM TO ANY PARTICULAR FONT, STYLE, SIZE, OR COLOR.

NO CLAIM IS MADE TO THE EXCLUSIVE RIGHT TO USE "ORGANICALLY", APART FROM THE MARK AS SHOWN.

FOR ORGANIC BEVERAGES, NAMELY, FRUIT-FLAVORED WATER AND TEA; FRUIT-FLAVORED WATER AND NON-ALCOHOLIC BEVERAGES WITH TEA FLAVOR (U.S. CLS. 45, 46 AND 48).

KELLY BOULTON, EXAMINING ATTORNEY

**CLASS 32—(Continued).**

SN 77-882,581. A&L GROUP LIMITED, BRIARCLIFF MANOR, NY. FILED 11-30-2009.

**DOCTORS SELECT**

THE MARK CONSISTS OF STANDARD CHARACTERS WITHOUT CLAIM TO ANY PARTICULAR FONT, STYLE, SIZE, OR COLOR.

NO CLAIM IS MADE TO THE EXCLUSIVE RIGHT TO USE "SELECT", APART FROM THE MARK AS SHOWN.

FOR NON-ALCOHOLIC BEVERAGES, NAMELY, CARBONATED WATERS, NON-CARBONATED SOFT-DRINKS AND FLAVORED WATERS (U.S. CLS. 45, 46 AND 48).

JEFF DEFORD, EXAMINING ATTORNEY

**CLASS 32—(Continued).**

SN 77-892,896. PASSI AG, ROTHRIST, SWITZERLAND, FILED 12-14-2009.



OWNER OF U.S. REG. NOS. 2,268,538 AND 3,686,239.

THE MARK CONSISTS OF A FIGURE OF A MAN DESIGN MADE UP OF DIFFERENT FRUITS; A PINEAPPLE DESIGN FOR THE HEAD; OVAL LEMON OR LIME SHAPE FOR THE BODY, CURVED SHAPED SUCH AS BANANA SHAPE DESIGN FOR THE ARMS AND PEAR SHAPE DESIGN FOR THE LEGS; THE WORD "PASSINA" APPEARS TO THE RIGHT OF THE DESIGN ELEMENT.

THE WORD(S) "PASSINA" HAS NO MEANING IN A FOREIGN LANGUAGE.

FOR FRUIT JUICES; CONCENTRATED FRUIT JUICES; SYRUPS, ESSENCES AND NON-ALCOHOLIC FRUIT EXTRACTS USED FOR MAKING SOFTDRINKS AND FRUIT JUICES (U.S. CLS. 45, 46 AND 48).

FIRST USE 10-1-2007; IN COMMERCE 10-1-2007.

SANDRA BUJA, EXAMINING ATTORNEY

SN 77-942,529. CJ CHEILJEDANG CORPORATION, SEOUL, REPUBLIC OF KOREA, FILED 2-23-2010.

SN 77-883,352. BOOM ENERGY DRINK LLC, HAINES CITY, FL. FILED 12-1-2009.



NO CLAIM IS MADE TO THE EXCLUSIVE RIGHT TO USE "ENERGY DRINK", APART FROM THE MARK AS SHOWN.

THE COLOR(S) RED, ORANGE, YELLOW, BLACK, AND WHITE IS/ARE CLAIMED AS A FEATURE OF THE MARK.

THE MARK CONSISTS OF THE DESIGNED WORDING "BOOM" IN ORANGE AND WHITE COLORS, OUTLINED IN WHITE AND RED. THE LETTERS "OO" THEREIN ARE REPRESENTED BY TWO CHERRY BOMBS WITH BLACK BUTTONS ON THE TOP AND YELLOW WICKS PROTRUDING THEREFROM. ABOVE THESE "OO" LETTERS IS A WHITE, YELLOW AND ORANGE SPARK DESIGN. LOCATED BELOW THE WORD "BOOM" IS THE WORDING "ENERGY DRINK" IN RED AND ORANGE COLORS.

FOR ENERGY DRINKS (U.S. CLS. 45, 46 AND 48).

DAWN HAN, EXAMINING ATTORNEY



OWNER OF U.S. REG. NOS. 3,775,797 AND 3,775,799.

NO CLAIM IS MADE TO THE EXCLUSIVE RIGHT TO USE THE NON-LATIN CHARACTERS THAT TRANSLITERATE TO "HEOTGAE" AND "POWER" AND THE DESIGN OF THE LEAVES AND FRUIT OF THE JAPANESE RAISIN TREE, APART FROM THE MARK AS SHOWN.

THE COLOR(S) GREEN, GOLD, BLACK, RED, YELLOW AND BROWN IS/ARE CLAIMED AS A FEATURE OF THE MARK.

THE MARK CONSISTS OF SOLID GREEN AT THE TOP LEFT WITH GOLD UPWARD SWEEPING STRIPES ON THE RIGHT APPEARING ABOVE A THICKER WAVY GOLD STRIPE WITH GREEN WAVY STRIPES APPEARING BENEATH IT TO THE LEFT AND RIGHT. UNDERNEATH THESE STRIPES IS A BLACK AREA TO THE RIGHT WITH A BLACK AND GREEN GRID BENEATH IT CONTAINING RED KOREAN CHARACTERS APPEARING TO THE LEFT AND ABOVE LARGER GOLD KOREAN CHARACTERS IN THE CENTER. SMALLER GOLD KOREAN CHARACTERS APPEAR BENEATH THE CENTER KOREAN CHARAC-

**CLASS 32—(Continued).**

TERS TO THE RIGHT. VARIOUS SIZED YELLOW/GREEN CIRCLES APPEAR THROUGHOUT THE GRID. A LARGE AND POINTED GREEN LEAF APPEARS AT THE BOTTOM LEFT OF THE GRID. ON TOP OF THE LEAF ARE THE BLACK RAISIN-SHAPED FRUIT AND BROWN FRUIT STALKS OF A JAPANESE RAISIN TREE. TO THE BOTTOM LEFT OF THE LEAF IS A THICK RED STRIPE; TO THE RIGHT OF THE LEAF ARE UPWARD SWEEPING STRIPES IN GREEN, GOLD AND RED. A SOLID BLACK AREA APPEARS AT THE BOTTOM OF THE MARK.

THE TOP TWO KOREAN CHARACTERS IN THE MARK TRANSLITERATE TO "HEOTGAE" AND MEAN "HOVENIA DULCIS". THE THREE MIDDLE KOREAN CHARACTERS IN THE MARK TRANSLITERATE TO "CON" "DI" AND "TION" AND MEAN "CONDITION". THE TWO BOTTOM KOREAN CHARACTERS IN THE MARK TRANSLITERATE TO "PO" AND "WER" AND MEAN "POWER".

FOR NON-ALCOHOLIC DRINKS TO RELIEVE A HANGOVER, NAMELY, SOFT DRINKS AND ENERGY DRINKS WITH ANTI-HANGOVER HEALTH SUPPLEMENTS; NON-ALCOHOLIC DRINKS TO PREVENT AND/OR ELIMINATE A HANGOVER, NAMELY, SOFT DRINKS AND ENERGY DRINKS WITH ANTI-HANGOVER HEALTH SUPPLEMENTS; NON-ALCOHOLIC DRINKS, NAMELY, TONIC SOFT DRINKS (U.S. CLS. 45, 46 AND 48).

KHANH LE, EXAMINING ATTORNEY

**CLASS 32—(Continued).**

SN 79-084,117. BALTIKA BREWERIES, RUSSIAN FED., FILED 12-23-2009.



SN 77-957,741. THE COCA-COLA COMPANY, ATLANTA, GA. FILED 3-12-2010.

**HUMAN HORSEPOWER**

THE MARK CONSISTS OF STANDARD CHARACTERS WITHOUT CLAIM TO ANY PARTICULAR FONT, STYLE, SIZE, OR COLOR.

FOR ENERGY DRINKS (U.S. CLS. 45, 46 AND 48).

FIRST USE 1-0-2006; IN COMMERCE 1-0-2006.

ELI HELLMAN, EXAMINING ATTORNEY

PRIORITY DATE OF 6-29-2009 IS CLAIMED.

OWNER OF INTERNATIONAL REGISTRATION 1042934 DATED 12-23-2009, EXPIRES 12-23-2019.

NO CLAIM IS MADE TO THE EXCLUSIVE RIGHT TO USE "ZATECKÝ", APART FROM THE MARK AS SHOWN.

THE COLOR(S) DARK GREEN, YELLOW, DARK RED, OLIVE-GREEN, GREY AND WHITE IS/ARE CLAIMED AS A FEATURE OF THE MARK.

THE BACKGROUND OF CENTRAL PART IS IN OLIVE-GREEN; THE OTHER PART OF THE BACKGROUND CONSISTS OF LINES IN YELLOW AND IN GREEN; VERBAL ELEMENTS LOCATED IN CENTRAL PART ARE IN GREEN AND YELLOW; THE GRAPHIC COMPOSITION LOCATED ABOVE VERBAL ELEMENTS IS IN DARK-RED, WHITE AND YELLOW; THE GRAPHIC COMPOSITION LOCATED UNDER VERBAL ELEMENTS IS IN GREY.

THE APPLIED MARK IS A COMPOSITION OF THE RIGHT-ANGLED FORM WITH AN OLIVE-GREEN OVAL AND VERBAL ELEMENTS IN THE CENTER; THE EMBLEM DECORATED WITH ORNAMENTAL ELEMENTS, CROWN AND A BIRD HEAD LOCATED ABOVE THE VERBAL ELEMENTS; THE BOTTOM PART CONTAINS A CITY PANORAMA IN GREY PHOTOGRAPHIC TECHNIQUE.

FOR BEER (U.S. CLS. 45, 46 AND 48).

MARGERY A. TIERNEY, EXAMINING ATTORNEY



**CLASS 32—(Continued).**

SN 79-089,807. GIONTAS HOLDINGS LIMITED, CY-1066 NICOSIA, CYPRUS, FILED 9-13-2010.

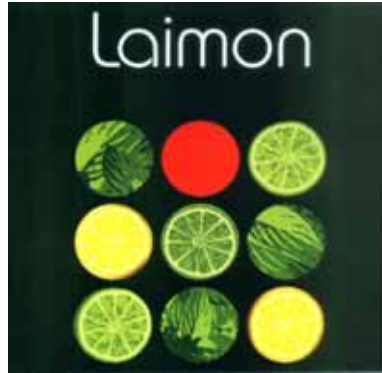

PRIORITY DATE OF 7-19-2010 IS CLAIMED.  
OWNER OF INTERNATIONAL REGISTRATION 1057840 DATED 9-13-2010, EXPIRES 9-13-2020.

THE COLOR(S) DARK GREEN, YELLOW, GREEN, RED AND WHITE IS/ARE CLAIMED AS A FEATURE OF THE MARK.

THE MARK CONSISTS OF "LAIMON" IN WHITE ON A DARK GREEN BACKGROUND, ABOVE A DESIGN FEATURING NINE CIRCLES MAKING A SQUARE IN WHICH THE TOP CENTER CIRCLE IS RED, THREE OF THE CIRCLES ARE COMPRISED OF GREEN SLICES OF LIME, TWO OF THE CIRCLES ARE COMPRISED OF YELLOW SLICES OF LEMON, AND THREE OF THE CIRCLES ARE COMPRISED OF GREEN STYLIZED LEAVES.

THE WORDING "LAIMON" HAS NO MEANING IN A FOREIGN LANGUAGE.

FOR BEER; FRUIT DRINKS; LEMONADES; NON-ALCOHOLIC DRINKS, NAMELY, SOFT DRINKS (U.S. CLS. 45, 46 AND 48).

KATHY DE JONGE, EXAMINING ATTORNEY

**CLASS 32—(Continued).**

SN 85-015,433. D'UVA, NICK, TOMS RIVER, NJ. FILED 4-16-2010.

**JERSEY JUICE**

THE MARK CONSISTS OF STANDARD CHARACTERS WITHOUT CLAIM TO ANY PARTICULAR FONT, STYLE, SIZE, OR COLOR.

NO CLAIM IS MADE TO THE EXCLUSIVE RIGHT TO USE "JUICE", APART FROM THE MARK AS SHOWN.

FOR LIGHT BEVERAGE PRODUCTS, NAMELY, BEERS; MINERAL AND AERATED WATERS; AERATED FRUIT JUICES, FROZEN FRUIT BEVERAGES; SODA POPS; FRUIT DRINKS AND FRUIT JUICES; SYRUPS FOR MAKING BEVERAGES FOR CONSUMERS; PREPARATIONS FOR MAKING FRUIT DRINKS, BEERS, MINERAL AND AERATED WATERS, FRUIT JUICES, FROZEN FRUIT BEVERAGES, AND SODA POPS (U.S. CLS. 45, 46 AND 48).

REBECCA POVARCHUK, EXAMINING ATTORNEY

SN 85-015,625. DIAGEO IRELAND, DUBLIN 8, IRELAND, FILED 4-16-2010.



SN 85-008,639. AKUNA CZ S.R.O., BRNO, CZECH REPUBLIC, FILED 4-7-2010.



THE MARK CONSISTS OF THE WORDS "ONYX PLUS" IN STYLIZED FORMAT AND ENCLOSED IN A RECTANGLE.

FOR MINERAL BEVERAGES, NAMELY, WATER INFUSED WITH MINERALS AND FRUIT JUICES (U.S. CLS. 45, 46 AND 48).

MICHELLE DUBOIS, EXAMINING ATTORNEY

OWNER OF U.S. REG. NOS. 321,014 AND 3,284,454.  
NO CLAIM IS MADE TO THE EXCLUSIVE RIGHT TO USE "GOLD" AND "MASTER BREWERS SINCE 1759", APART FROM THE MARK AS SHOWN.

THE NAME(S), PORTRAIT(S), AND/OR SIGNATURE(S) SHOWN IN THE MARK DOES NOT IDENTIFY A PARTICULAR LIVING INDIVIDUAL.

THE MARK CONSISTS OF AN OVAL WITH THE WORDS "ARTHUR GUINNESS & SON" IN THE BORDER OF THE UPPER PORTION OF THE OVAL AND "MASTER BREWERS SINCE 1759" IN THE BORDER OF THE LOWER PORTION OF THE OVAL WITH THE WORD "GUINNESS" APPEARING ABOVE THE WORD "GOLD" IN THE CENTER OF THE OVAL WITH A TWO HORSE SEAL APPEARING DIRECTLY ABOVE THE WORDS "GUINNESS GOLD" AND THE "ARTHUR GUINNESS" SIGNATURE APPEARING DIRECTLY BELOW THESE WORDS.

FOR BEER (U.S. CLS. 45, 46 AND 48).

JENNIFER VASQUEZ, EXAMINING ATTORNEY

**CLASS 32—(Continued).**

SN 85-023,474. ALVARO MOLINA, CLAREMONT, CA.  
FILED 4-26-2010.

**DON TEPACHE**

THE MARK CONSISTS OF STANDARD CHARACTERS WITHOUT CLAIM TO ANY PARTICULAR FONT, STYLE, SIZE, OR COLOR.

NO CLAIM IS MADE TO THE EXCLUSIVE RIGHT TO USE "TEPACHE", APART FROM THE MARK AS SHOWN.

THE ENGLISH TRANSLATION OF "DON TEPACHE" IN THE MARK IS "MR. TEPACHE".

FOR BREWED FERMENTED PINEAPPLE FRUIT DRINKS (U.S. CLS. 45, 46 AND 48).

FIRST USE 3-10-2010; IN COMMERCE 3-10-2010.  
NICHOLAS ALTREE, EXAMINING ATTORNEY

**CLASS 32—(Continued).**

SN 85-071,223. XL ENERGY DRINK CORP., NEW YORK, NY. FILED 6-24-2010.



OWNER OF U.S. REG. NOS. 3,339,184, 3,796,008 AND OTHERS.

NO CLAIM IS MADE TO THE EXCLUSIVE RIGHT TO USE "USA", APART FROM THE MARK AS SHOWN.

THE COLOR(S) BLUE, RED, GREY IS/ARE CLAIMED AS A FEATURE OF THE MARK.

THE MARK CONSIST OF THE LETTERS "USA" IN STYLIZED FONT IN BLUE AND TO THE LEFT OF THE LETTERS "XL" WHICH APPEAR IN STYLIZED FONT IN RED BORDERED IN BLUE AND GRAY, AND ALL APPEARING ON A BLUE BACKGROUND.

FOR NON-ALCOHOLIC BEVERAGES, NAMELY, ENERGY DRINKS (U.S. CLS. 45, 46 AND 48).

JULIE WATSON, EXAMINING ATTORNEY

SN 85-033,909. MOTT'S LLP, RYE BROOK, NY. FILED 5-10-2010.

**GARDEN BLEND**

THE MARK CONSISTS OF STANDARD CHARACTERS WITHOUT CLAIM TO ANY PARTICULAR FONT, STYLE, SIZE, OR COLOR.

NO CLAIM IS MADE TO THE EXCLUSIVE RIGHT TO USE "BLEND", APART FROM THE MARK AS SHOWN.

FOR NON-CARBONATED FRUIT AND VEGETABLE JUICES (U.S. CLS. 45, 46 AND 48).

STEVEN R. FINE, EXAMINING ATTORNEY

SN 85-081,407. MILLERCOORS LLC, CHICAGO, IL. FILED 7-9-2010.

IT'S OFFICIAL. IT'S COLD.

SN 85-044,330. WINERY EXCHANGE, INC., NOVATO, CA.  
FILED 5-20-2010.

**BLOC 70**

THE MARK CONSISTS OF STANDARD CHARACTERS WITHOUT CLAIM TO ANY PARTICULAR FONT, STYLE, SIZE, OR COLOR.

NO CLAIM IS MADE TO THE EXCLUSIVE RIGHT TO USE "70", APART FROM THE MARK AS SHOWN.

FOR BEER (U.S. CLS. 45, 46 AND 48).  
INGA ERVIN, EXAMINING ATTORNEY

THE MARK CONSISTS OF STANDARD CHARACTERS WITHOUT CLAIM TO ANY PARTICULAR FONT, STYLE, SIZE, OR COLOR.

NO CLAIM IS MADE TO THE EXCLUSIVE RIGHT TO USE "COLD", APART FROM THE MARK AS SHOWN.

FOR BEER (U.S. CLS. 45, 46 AND 48).  
INGA ERVIN, EXAMINING ATTORNEY

**CLASS 32—(Continued).**

SN 85-153,554. EDWARDS, TAUNDA, MARIETTA, GA.  
FILED 10-15-2010.



THE MARK CONSISTS OF THE STYLIZED WORDING "B= TOO", WITH "B=" AND THE LETTERS "T", "O" AND "O" INSIDE TILTED RECTANGLES, ALL INSIDE A SHADED, SLANTED RECTANGULAR BACKGROUND, AND ALL ABOVE THE WORDS "ONE BEVERAGE=TOO MANY REASONS TO ENJOY".

FOR FRUIT-FLAVORED BEVERAGES (U.S. CLS. 45, 46 AND 48).

ELISSA GARBER KON, EXAMINING ATTORNEY

SN 85-153,560. CERVECERIA NACIONAL CN SA, GUAYAQUIL, ECUADOR, FILED 10-15-2010.



NO CLAIM IS MADE TO THE EXCLUSIVE RIGHT TO USE "SABOR DISTINGUIDO", "DESDE 1966", "PREMIUM", "CALIDAD DE EXPORTACION", AND "CONTENIDO NETO 330 CM3 GRADO ALCOHOLICO 4.4 GL", APART FROM THE MARK AS SHOWN.

THE COLOR(S) BROWN, GREEN, GOLD, RED, WHITE, BLACK, GRAY IS/ARE CLAIMED AS A FEATURE OF THE MARK.

THE MARK CONSISTS OF A WHITE RIBBON SHAPE OUTLINED IN GREEN AND GOLD, WITH A ROUND GOLD-COLORED MEDALLION AT THE TOP OF THE RIBBON SHAPE, WITH THE WORDS "SABOR DISTINGUIDO" AT THE TOP OF THE MEDALLION, "DESDE 1966" AT THE BOTTOM OF THE MEDALLION, AND A DESIGN OF BARLEY AND HOPS IN THE CENTER OF THE MEDALLION, ALL DEPICTED IN GOLD RELIEF WITH BROWN DROPSHADOW; BENEATH THE MEDALLION, THE

**CLASS 32—(Continued).**

WORD "CLUB" APPEARS IN BLACK WITH GRAY DROPSHADOW AND WHITE LINING ON THE BLACK LETTERS; BELOW THE WORD "CLUB", THE WORD "PREMIUM" APPEARS IN WHITE INSIDE A RED-RIBBON WITH GOLD STRIPES RUNNING ACROSS THE TOP AND BOTTOM OF THE RED RIBBON; BELOW THE RED RIBBON, THE WORDS "CALIDAD DE EXPORTACION" APPEAR IN GRAY; THE WORDS "CONTENIDO NETO 330 CM3 GRADO ALCOHOLICO 4.4 GL" APPEAR AT THE BOTTOM OF THE DESIGN IN BROWN LETTERS.

THE ENGLISH TRANSLATION OF "SABOR DISTINGUIDO" AND "DESDE 1966" AND "CALIDAD DE EXPORTACION" AND "CONTENIDO NETO 330 CM3" AND "GRADO ALCOHOLICO 4.4 GL" IN THE MARK IS "TASTE DISTINGUISHED" AND "FROM 1966" AND "QUALITY OF EXPORT" AND "NET CONTENT 330 CM3" AND "STRENGTH ALCOHOL 4.4 GL".

FOR BEER (U.S. CLS. 45, 46 AND 48).

BRENDAN REGAN, EXAMINING ATTORNEY

SN 85-155,218. PARAGON FOOD SERVICE CORPORATION, DBA LEFT COAST BREWING CO., SAN CLEMENTE, CA. FILED 10-18-2010.



NO CLAIM IS MADE TO THE EXCLUSIVE RIGHT TO USE "AMERICAN STOUT", APART FROM THE MARK AS SHOWN.

THE COLOR(S) BLACK, WHITE, GREY AND PURPLE IS/ARE CLAIMED AS A FEATURE OF THE MARK.

THE MARK CONSISTS OF A SKELETON HEAD OUTLINED IN WHITE AND SHADED IN BLACK, WEARING A BLACK TOP HAT WITH A GREY BAND AND A BLACK CAPE OUTLINED WITH A GREY BAND ACROSS THE TOP OF THE CAPE AND PURPLE FLAMES ACROSS THE BOTTOM OF THE CAPE. WHITE SKELETON HANDS OUTLINED IN BLACK ARE OUT TO THE LEFT AND RIGHT SIDE OF THE CAPE. THE RIGHT SKELETON HAND IS HOLDING A CANE TINGED WITH BLACK AND WHITE WITH A SKELETON ON TOP OF THE CANE. THE WORD "VOO" IN WHITE WITH BLACK SHADING SITS IN THE MIDDLE OF THE CAPE BELOW THE SKELETON HEAD, AND THE WORD "DOO" IN WHITE WITH BLACK SHADING SITS RIGHT BELOW THE WORD "VOO". THE WORDS "AMERICAN STOUT" APPEAR IN WHITE ALONG A GREY BAND AT THE BOTTOM OF THE MARK. JUST ABOVE THE GREY BAND IS A BLACK AND WHITE ORNATE DESIGN SEPARATING THE GREY BAND FROM THE BLACK CAPE.

FOR BEER, ALE, LAGER, STOUT AND PORTER (U.S. CLS. 45, 46 AND 48).

FIRST USE 9-1-2010; IN COMMERCE 9-1-2010.

KATHERINE M. DUBRAY, EXAMINING ATTORNEY

**CLASS 32—(Continued).**

SN 85-155,360. RLED, LLC, SUN VALLEY, CA. FILED 10-18-2010.

**THE PERFECT ALTERNATIVE**

THE MARK CONSISTS OF STANDARD CHARACTERS WITHOUT CLAIM TO ANY PARTICULAR FONT, STYLE, SIZE, OR COLOR.

FOR BEAUTY BEVERAGES, NAMELY, FRUIT JUICES AND ENERGY DRINKS CONTAINING NUTRITIONAL SUPPLEMENTS; COLAS; CONCENTRATES, SYRUPS OR POWDERS USED IN THE PREPARATION OF SOFT DRINKS (U.S. CLS. 45, 46 AND 48).

DAVID HOFFMAN, EXAMINING ATTORNEY

SN 85-157,568. THOMAS ARNDT, LOS ANGELES, CA. FILED 10-20-2010.

**Lemonita**

THE MARK CONSISTS OF STANDARD CHARACTERS WITHOUT CLAIM TO ANY PARTICULAR FONT, STYLE, SIZE, OR COLOR.

FOR SOFT DRINKS, NAMELY, CARBONATED AND NON CARBONATED BEVERAGES, LEMONADE, AND LEMON BASED BEVERAGES (U.S. CLS. 45, 46 AND 48).

KRISTIN DAHLING, EXAMINING ATTORNEY

SN 85-158,467. LIGHTS OUT LLC, DBA BANGER BREWING COMPANY, LAS VEGAS, NV. FILED 10-21-2010.

**BANGER BREWING**

THE MARK CONSISTS OF STANDARD CHARACTERS WITHOUT CLAIM TO ANY PARTICULAR FONT, STYLE, SIZE, OR COLOR.

NO CLAIM IS MADE TO THE EXCLUSIVE RIGHT TO USE "BREWING", APART FROM THE MARK AS SHOWN. FOR BEER (U.S. CLS. 45, 46 AND 48).

ROBIN MITTLER, EXAMINING ATTORNEY

**CLASS 32—(Continued).**

SN 85-163,652. HOPUNION, L.L.C., YAKIMA, WA. FILED 10-28-2010.

**FALCONER'S FLIGHT**

THE MARK CONSISTS OF STANDARD CHARACTERS WITHOUT CLAIM TO ANY PARTICULAR FONT, STYLE, SIZE, OR COLOR.

FOR PROCESSED HOPS, NAMELY, PELLETIZED HOPS (U.S. CLS. 45, 46 AND 48).

JOHN GARTNER, EXAMINING ATTORNEY

SN 85-169,550. SUMAN, SHAILENDRA K., MATTHEWS, NC. FILED 11-4-2010.



THE COLOR(S) BLUE, WHITE AND YELLOW IS/ARE CLAIMED AS A FEATURE OF THE MARK.

THE MARK CONSISTS OF THE STYLIZED WORDING "SMARTCHARGE" WHEREIN THE LETTER "T" APPEARS AS THE SYMBOL "+". THE WORD "SMART" IS IN WHITE LETTERING. THE WORD "CHARGE" IS IN YELLOW LETTERING. THE WORDING APPEARS ON A BLUE BACKGROUND THAT IS GENERALLY RECTANGULAR IN SHAPE, AND WHICH INCORPORATES A YELLOW RECTANGULAR OUTLINE.

FOR ENERGY DRINKS; FLAVORED WATERS (U.S. CLS. 45, 46 AND 48).

FIRST USE 10-1-2010; IN COMMERCE 10-1-2010.

KIM MONINGHOFF, EXAMINING ATTORNEY

SN 85-170,961. CLEVELAND BEER COMPANY, SHAKER HTS., OH. FILED 11-7-2010.

**Bockzilla**

THE MARK CONSISTS OF STANDARD CHARACTERS WITHOUT CLAIM TO ANY PARTICULAR FONT, STYLE, SIZE, OR COLOR.

FOR BOCK-STYLE BEER (U.S. CLS. 45, 46 AND 48).

ANNE MADDEN, EXAMINING ATTORNEY

**CLASS 32—(Continued).**

SN 85-173,467. SOULCYCLE, LLC, NEW YORK, NY. FILED 11-10-2010.



OWNER OF U.S. REG. NOS. 3,824,895, 3,844,347 AND OTHERS.

THE MARK CONSISTS OF A BIKE WHEEL WITH MULTIPLE SPOKES.

FOR BOTTLED WATER (U.S. CLS. 45, 46 AND 48).  
BRENDAN REGAN, EXAMINING ATTORNEY

SN 85-173,493. NESTLE WATERS NORTH AMERICA, INC., GREENWICH, CT. FILED 11-10-2010.

**NATURE'S FIX**

THE MARK CONSISTS OF STANDARD CHARACTERS WITHOUT CLAIM TO ANY PARTICULAR FONT, STYLE, SIZE, OR COLOR.

FOR SPRING WATER, SPARKLING SPRING WATER (U.S. CLS. 45, 46 AND 48).

BRENDAN REGAN, EXAMINING ATTORNEY

SN 85-178,344. LOWELL INTERNATIONAL COMPANY, FRANKLIN PARK, IL. FILED 11-16-2010.



THE COLOR(S) BLACK, WHITE, BLUE, ORANGE, GREEN, AND RED IS/ARE CLAIMED AS A FEATURE OF THE MARK.

THE MARK CONSISTS OF THE WORD "BUENA" WITH A CAPITAL "B" ON TOP OF THE WORD "CARROTENA" WITH A CAPITAL "C". THE WORD "CARROTENA" APPEARS AS A SEMI-CIRCLE THAT CURVES UP AROUND THE SIDES OF THE WORD "BUENA". THE WORD "BUENA" AND THE WORD "CARROTENA" APPEAR IN A BLUE

**CLASS 32—(Continued).**

COLOR. THE LETTERS ARE STYLIZED. THE LETTER "T" IN "CARROTENA" IS ORANGE AND LOOKS LIKE A SMILING CARROT WITH EARS. THE BOTTOM OF THE CARROT CURVES TO THE RIGHT. THE BODY AND EARS OF THE CARROT ARE ORANGE. THE TOP OF THE CARROT HAS GREEN LEAVES. THE CARROT HAS WHITE OVAL EYES WITH BLACK PUPILS. IT HAS BLACK EYEBROWS. THE SMILE ON THE CARROT SHOWS A BLACK MOUTH WITH A THIN BLACK MUSTACHE. THE MOUTH HAS A RED TONGUE AND TWO SMALL WHITE TEETH.

THE ENGLISH TRANSLATION OF BUENA IN THE MARK IS GOOD. THE WORDING CARROTENA HAS NO MEANING IN A FOREIGN LANGUAGE.

FOR VEGETABLE DRINKS; VEGETABLE JUICE; VEGETABLE-FRUIT JUICES (U.S. CLS. 45, 46 AND 48).  
DORITT L. CARROLL, EXAMINING ATTORNEY

SN 85-178,348. KINETIX LIVING CORP., SEATTLE, WA. FILED 11-16-2010.

**Rebel. Ignite. Commit.**

THE MARK CONSISTS OF STANDARD CHARACTERS WITHOUT CLAIM TO ANY PARTICULAR FONT, STYLE, SIZE, OR COLOR.

FOR ENERGY DRINKS; SPORTS DRINKS (U.S. CLS. 45, 46 AND 48).

GIANCARLO CASTRO, EXAMINING ATTORNEY

SN 85-179,065. GREEN SHEEP, LLC, MIAMI, FL. FILED 11-17-2010.

**GREEN SHEEP**

THE MARK CONSISTS OF STANDARD CHARACTERS WITHOUT CLAIM TO ANY PARTICULAR FONT, STYLE, SIZE, OR COLOR.

FOR WATER BEVERAGES (U.S. CLS. 45, 46 AND 48).  
KAREN SEVERSON, EXAMINING ATTORNEY

SN 85-198,910. RAMAR INTERNATIONAL CORPORATION, PITTSBURG, CA. FILED 12-15-2010.

**ENJOY THE FRUITS OF OUR LABOR**

THE MARK CONSISTS OF STANDARD CHARACTERS WITHOUT CLAIM TO ANY PARTICULAR FONT, STYLE, SIZE, OR COLOR.

FOR FRUIT NECTARS, FRUIT DRINKS AND FRUIT JUICES (U.S. CLS. 45, 46 AND 48).

FIRST USE 1-1-2009; IN COMMERCE 1-1-2009.  
LOURDES AYALA, EXAMINING ATTORNEY

**CLASS 32—(Continued).**

SN 85-203,339. NECTAVÉ, INC., SAN DIEGO, CA. FILED 12-21-2010.



OWNER OF U.S. REG. NO. 3,901,936.  
THE MARK CONSISTS OF A STYLIZED AGAVE PLANT WITH LEAVES IN TEARDROP SHAPE IN THE CENTER, AND THE WORD "NECTAVE" (PRONOUNCED NEK-TAH-VAY) WITH A LEAF-SHAPED ACCENT OVER THE LETTER "E".

FOR AGAVE NECTAR (U.S. CLS. 45, 46 AND 48).  
FIRST USE 9-24-2010; IN COMMERCE 10-20-2010.  
MAYUR VAGHANI, EXAMINING ATTORNEY

SN 85-203,608. PEPSICO, INC., PURCHASE, NY. FILED 12-22-2010.

**GO AHHHH**

THE MARK CONSISTS OF STANDARD CHARACTERS WITHOUT CLAIM TO ANY PARTICULAR FONT, STYLE, SIZE, OR COLOR.  
FOR SOFT DRINKS (U.S. CLS. 45, 46 AND 48).  
MORGAN WYNNE, EXAMINING ATTORNEY

**CLASS 33—WINES AND SPIRITS**

SN 77-487,201. VISTAFLORES ESTATE S.A., MENDOZA, ARGENTINA, FILED 5-30-2008.

**ALTAMIRA DE LOS ANDES**

THE MARK CONSISTS OF STANDARD CHARACTERS WITHOUT CLAIM TO ANY PARTICULAR FONT, STYLE, SIZE, OR COLOR.

NO CLAIM IS MADE TO THE EXCLUSIVE RIGHT TO USE "LOS ANDES", APART FROM THE MARK AS SHOWN. THE ENGLISH TRANSLATION OF THE WORDS "ALTAMIRA DE LOS ANDES" IN THE MARK IS "HIGH VISION OF THE ANDES".

FOR WINE (U.S. CLS. 47 AND 49).  
ODESSA BIBBINS, EXAMINING ATTORNEY

SN 77-620,148. SAZERAC COMPANY, INC., NEW ORLEANS, LA. FILED 11-22-2008.

**HDW CLIX**

THE MARK CONSISTS OF STANDARD CHARACTERS WITHOUT CLAIM TO ANY PARTICULAR FONT, STYLE, SIZE, OR COLOR.

FOR VODKA (U.S. CLS. 47 AND 49).  
RONALD DELGIZZI, EXAMINING ATTORNEY

SN 77-835,320. ALLIED DOMEQ SPIRITS & WINE LIMITED, LONDON W6 9RS, UNITED KINGDOM, FILED 9-25-2009.

**LONDONIZE**

THE MARK CONSISTS OF STANDARD CHARACTERS WITHOUT CLAIM TO ANY PARTICULAR FONT, STYLE, SIZE, OR COLOR.

OWNER OF ERPN CMNTY TM OFC REG. NO. 008573016, DATED 12-28-2010, EXPIRES 9-24-2019.

FOR ALCOHOLIC BEVERAGES EXCEPT BEER (U.S. CLS. 47 AND 49).  
DOUGLAS LEE, EXAMINING ATTORNEY

**CLASS 33—(Continued).**

SN 77-913,351. BORQUEZ, ELANE, LOS ANGELES, CA.  
FILED 1-15-2010.

**Sacred Cellar**

THE MARK CONSISTS OF STANDARD CHARACTERS WITHOUT CLAIM TO ANY PARTICULAR FONT, STYLE, SIZE, OR COLOR.

NO CLAIM IS MADE TO THE EXCLUSIVE RIGHT TO USE "CELLAR", APART FROM THE MARK AS SHOWN.

FOR WINE (U.S. CLS. 47 AND 49).  
HEATHER SAPP, EXAMINING ATTORNEY

**CLASS 33—(Continued).**

SN 77-968,347. RAVANDI, DAVID, BEVERLY HILLS, CA.  
FILED 3-25-2010.

**DIABLITO**

THE MARK CONSISTS OF STANDARD CHARACTERS WITHOUT CLAIM TO ANY PARTICULAR FONT, STYLE, SIZE, OR COLOR.

THE ENGLISH TRANSLATION OF "DIABLITO" IN THE MARK IS "LITTLE DEVIL".

FOR MEZCAL; TEQUILA; TEQUILA INFUSED WITH VITAMINS (U.S. CLS. 47 AND 49).  
SANI KHOURI, EXAMINING ATTORNEY

SN 77-944,402. KAUTZ VINEYARDS, INC., MURPHEYS, CA.  
FILED 2-25-2010.

**LEAPING HORSE VINEYARDS**

THE MARK CONSISTS OF STANDARD CHARACTERS WITHOUT CLAIM TO ANY PARTICULAR FONT, STYLE, SIZE, OR COLOR.

NO CLAIM IS MADE TO THE EXCLUSIVE RIGHT TO USE "VINEYARDS", APART FROM THE MARK AS SHOWN.

FOR WINES (U.S. CLS. 47 AND 49).  
FIRST USE 9-1-2002; IN COMMERCE 9-1-2002.  
FONG HSU, EXAMINING ATTORNEY

SN 79-080,986. TOKAJ KERESKEDŐHÁZ ZRT., HUNGARY,  
FILED 3-2-2010.



SN 77-951,284. RATILOVSKIY, PAVEL, TABLE VIEW, CAPE TOWN, SOUTH AFRICA, FILED 3-5-2010.

**John Black**

THE MARK CONSISTS OF STANDARD CHARACTERS WITHOUT CLAIM TO ANY PARTICULAR FONT, STYLE, SIZE, OR COLOR.

THE NAME(S), PORTRAIT(S), AND/OR SIGNATURE(S) SHOWN IN THE MARK DOES NOT IDENTIFY A PARTICULAR LIVING INDIVIDUAL.

FOR VODKA (U.S. CLS. 47 AND 49).  
KATHERINE M. DUBRAY, EXAMINING ATTORNEY

OWNER OF INTERNATIONAL REGISTRATION 1034444 DATED 3-2-2010, EXPIRES 3-2-2020.

NO CLAIM IS MADE TO THE EXCLUSIVE RIGHT TO USE "KERESKEDOHAZ RT", "TOKAJ", "TOKAJI", OR "1650", APART FROM THE MARK AS SHOWN.

THE COLOR(S) YELLOW, GOLD, GREEN, RED, WHITE AND BLACK IS/ARE CLAIMED AS A FEATURE OF THE MARK.

THE MARK CONSISTS OF THE FOLLOWING: A GOLD CROWN OUTLINED IN BLACK WITH A RED, WHITE AND GREEN RIBBON DIRECTLY UNDERNEATH. THE WORDING "VINUM REGUM REX VINORUM AND 1650" APPEAR IN A STRAIGHT LINE BENEATH THE CROWN AND RIBBON IN THE COLOR BLACK. BELOW THAT IS THE WORDING "TOKAJI" IN YELLOW OUTLINED IN BLACK, WITH TWO BLACK LINES BENEATH THE WORD. BENEATH THAT IS THE WORDING "TOKAJ KERESKEDOHAZ RT" ALL IN BLACK. THE ENTIRE MARK DESCRIBED ABOVE IS SURROUNDED BY A LABEL OUTLINE IN THE COLOR YELLOW.

THE ENGLISH TRANSLATION OF "KERESKEDOHAZ RT" IN THE MARK IS "TRADING HOUSE, LTD".

FOR WINES ORIGINATED FROM THE AREA OF APPELLATION OF ORIGIN TOKAJ (U.S. CLS. 47 AND 49).

SUSAN HAYASH, EXAMINING ATTORNEY

**CLASS 33—(Continued).**

SN 79-081,628. MASAI S.A., LUXEMBOURG, FILED 1-11-2010.



PRIORITY DATE OF 7-15-2009 IS CLAIMED.  
OWNER OF INTERNATIONAL REGISTRATION 1036118 DATED 1-11-2010, EXPIRES 1-11-2020.

NO CLAIM IS MADE TO THE EXCLUSIVE RIGHT TO USE "1808 MAISON FONDÉE A REIMS FRANCE", APART FROM THE MARK AS SHOWN.

THE COLOR(S) PINK (TRANSLUCENT LACQUER 1000G, WARM RED 73G, YELLOW 14G), GREY (BLACK 1860G, LACQUER 750G, REFLEX BLUE 200G, RUBY RED 06G), CREAM (LACQUER 1000G, YELLOW 15G, RUBY RED 16G), WHITE, BLACK IS/ARE CLAIMED AS A FEATURE OF THE MARK.

THE MARK CONSISTS OF ELEMENTS APPEARING ON PRODUCT PACKAGING WITH THE FOLLOWING APPEARING TWICE IN BOTH THE LEFT AND FRONT SIDE OF THE BOX WHERE THE COLOR CREAM APPEARS IN THE WORDING "HM 1808 HENRIOT MAISON FONDÉE A REIMS FRANCE" AND IN THE CREST DESIGN WHICH FEATURES TWO DOGS, AN OVAL DESIGN, AND THE LETTERS "HM". THE COLOR GREY APPEARS IN THE HORIZONTAL BAND AT THE BOTTOM OF THE BOX DESIGN WHICH INCLUDES THE CREAM WORDING "A REIMS FRANCE MAISON FONDÉE A REIMS FRANCE", AND THE MARK ALSO CONSISTS OF THREE OTHER HORIZONTAL AND SLIGHTLY HORIZONTAL BANDS CONSISTING OF THE COLOR PINK, CREAM, AND WHITE. THE MATTER SHOWN IN BROKEN LINES IS NOT PART OF THE MARK AND SERVES ONLY TO SHOW THE POSITION OR PLACEMENT OF THE MARK.

THE ENGLISH TRANSLATION OF "MAISON FONDÉE" IN THE MARK IS "HOUSE FOUNDED".

FOR FRENCH ALCOHOLIC BEVERAGES EXCEPT BEERS; FRENCH LIQUEURS; FRENCH SPIRITS; FRENCH WINES; FRENCH SPARKLING WINES; FRENCH WINES, NAMELY, WINES WITH CHAMPAGNE PROTECTED APPELLATION OF ORIGIN (U.S. CLS. 47 AND 49).

WARREN L. OLANDRIA, EXAMINING ATTORNEY

**CLASS 33—(Continued).**

SN 79-083,590. CONELLY COCKTAIL GMBH & CO. KG, A-6890 LUSTENAU, AUSTRIA, FILED 2-24-2010.

# BLUE BEACH

THE MARK CONSISTS OF STANDARD CHARACTERS WITHOUT CLAIM TO ANY PARTICULAR FONT, STYLE, SIZE, OR COLOR.

PRIORITY DATE OF 9-30-2009 IS CLAIMED.

OWNER OF INTERNATIONAL REGISTRATION 1041497 DATED 2-24-2010, EXPIRES 2-24-2020.

FOR MIXED ALCOHOLIC BEVERAGES WITH THE EXCEPTION OF BEERS, WITH THE EXCEPTION OF THOSE PREPARED ON THE BASIS OF WINE, AND WITH THE EXCEPTION OF ENERGY DRINKS AND SPORTS DRINKS; PREPARED ALCOHOLIC COCKTAILS WITH THE EXCEPTION OF THOSE PREPARED ON THE BASIS OF WINE AND WITH THE EXCEPTION OF ENERGY DRINKS AND SPORTS DRINKS (U.S. CLS. 47 AND 49).

MARGARET POWER, EXAMINING ATTORNEY

SN 79-083,793. TORMARESCA S.R.L., ITALY, FILED 4-30-2010.

# TRENTANGELI

THE MARK CONSISTS OF STANDARD CHARACTERS WITHOUT CLAIM TO ANY PARTICULAR FONT, STYLE, SIZE, OR COLOR.

PRIORITY DATE OF 11-17-2009 IS CLAIMED.

OWNER OF INTERNATIONAL REGISTRATION 1042145 DATED 4-30-2010, EXPIRES 4-30-2020.

THE WORDING "TRENTANGELI" HAS NO MEANING IN A FOREIGN LANGUAGE.

FOR ALCOHOLIC BEVERAGES, EXCEPT BEERS (U.S. CLS. 47 AND 49).

TRACY FLETCHER, EXAMINING ATTORNEY

SN 79-084,380. MORIIZO SHUZO CO., LTD., JAPAN, FILED 5-14-2010.

# MORIIZOU

THE MARK CONSISTS OF STANDARD CHARACTERS WITHOUT CLAIM TO ANY PARTICULAR FONT, STYLE, SIZE, OR COLOR.

PRIORITY DATE OF 4-20-2010 IS CLAIMED.

OWNER OF INTERNATIONAL REGISTRATION 1043479 DATED 5-14-2010, EXPIRES 5-14-2020.

THE NAME "MORIIZOU" DOES NOT IDENTIFY A LIVING INDIVIDUAL.

THE WORDING "MORIIZOU" HAS NO MEANING IN A FOREIGN LANGUAGE.

FOR JAPANESE WHITE LIQUOR (SHOCHU) (U.S. CLS. 47 AND 49).

MARK PILARO, EXAMINING ATTORNEY



**CLASS 33—(Continued).**

SN 79-084,952. MORIIZO SHUZO CO., LTD., JAPAN, FILED 4-23-2010.



OWNER OF INTERNATIONAL REGISTRATION 1044836 DATED 4-23-2010, EXPIRES 4-23-2020.

THE NAME "MORIIZOU" DOES NOT IDENTIFY A LIVING INDIVIDUAL.

THE MARK CONSISTS OF THREE VERTICALLY ARRANGED JAPANESE CHARACTERS.

THE NON-LATIN CHARACTERS IN THE MARK TRANSLITERATE TO "MORIIZOU" AND THIS HAS NO MEANING IN A FOREIGN LANGUAGE.

FOR JAPANESE WHITE LIQUOR (SHOCHU); DISTILLED LIQUORS AND SPIRITS (U.S. CLS. 47 AND 49).  
MARK PILARO, EXAMINING ATTORNEY

**CLASS 33—(Continued).**

SN 79-086,499. AZIENDA VINICOLA ANNA SPINATO S.A.S., ITALY, FILED 6-22-2010.



OWNER OF INTERNATIONAL REGISTRATION 1048800 DATED 6-22-2010, EXPIRES 6-22-2020.

NO CLAIM IS MADE TO THE EXCLUSIVE RIGHT TO USE "VIN", APART FROM THE MARK AS SHOWN.

THE MARK CONSISTS OF THE STYLIZED WORDING "EL VIN" APPEARING ABOVE A DESIGN COMPRISED OF SIXTEEN CIRCLES ARRANGED IN A FOUR-BY-FOUR ALIGNMENT INTO ROUGHLY THE SHAPE OF A SQUARE, WITH THE UPPER-RIGHT CIRCLE BEING IN THE NATURE OF A SMILEY-FACE DESIGN.

THE ENGLISH TRANSLATION OF THE WORD "VIN" IS "WINE".

FOR WINES (U.S. CLS. 47 AND 49).  
KEVIN CORWIN, EXAMINING ATTORNEY

SN 79-086,375. AMÉLIE BARROT, F-84230 CHATEAUNEUF DU PAPE, FRANCE, AND GAËLLE MAILLET, F-84230 CHATEAUNEUF DU PAPE, FRANCE, FILED 7-30-2010.

**FINES ROCHES**

PRIORITY DATE OF 2-18-2010 IS CLAIMED.  
OWNER OF INTERNATIONAL REGISTRATION 1048451 DATED 7-30-2010, EXPIRES 7-30-2020.

OWNER OF U.S. REG. NO. 3,576,351.  
NO CLAIM IS MADE TO THE EXCLUSIVE RIGHT TO USE "FINES", APART FROM THE MARK AS SHOWN.

THE ENGLISH TRANSLATION OF "FINES ROCHES" IN THE MARK IS "FINE ROCK".

FOR WINES WITH APPELLATION OF ORIGIN (U.S. CLS. 47 AND 49).  
SEAN CROWLEY, EXAMINING ATTORNEY

SN 85-021,146. THE RUSH CORPORATION, IRONDALE, AL. FILED 4-22-2010.

**RUSH**

THE MARK CONSISTS OF "RUSH" STYLIZED WITH THE LETTER "U" APPEARING AS A WINE GLASS HAVING WINE THEREIN.

FOR WINES (U.S. CLS. 47 AND 49).  
FIRST USE 4-30-2005; IN COMMERCE 4-30-2005.  
DOUGLAS LEE, EXAMINING ATTORNEY

**CLASS 33—(Continued).**

SN 85-023,738. KIM, YEUN-BAK, GYEONGSANGBOOKDO, REPUBLIC OF KOREA, FILED 4-27-2010.

조옥화안동소주  
趙玉花安東燒酎  
CHO OK HWA Andong Soju

NO CLAIM IS MADE TO THE EXCLUSIVE RIGHT TO USE NO CLAIM IS MADE TO THE EXCLUSIVE RIGHT TO USE "ANDONG SOJU" AND THE NON-LATIN CHARACTERS THAT TRANSLITERATE TO "ANDONG SOJU" APART FROM THE MARK AS SHOWN., APART FROM THE MARK AS SHOWN.

THE NAME(S), PORTRAIT(S), AND/OR SIGNATURE(S) SHOWN IN THE MARK IDENTIFIES "CHO OK HWA", WHOSE CONSENT(S) TO REGISTER IS MADE OF RECORD.

THE MARK CONSISTS OF THE WORDING "CHO OK HWA ANDONG SOJU" AND RELATED KOREAN CHARACTERS.

THE WORDING "CHO OK HWA" HAS NO MEANING IN A FOREIGN LANGUAGE AND IS THE NAME OF APPLICANT'S MOTHER. THE ENGLISH TRANSLATION OF "ANDONG SOJU" IN THE MARK IS THE TRADITIONAL MANUFACTURING PROCESS FOR "ANDONG SOJU".

THE TRANSLITERATION OF THE NON-LATIN CHARACTERS ABOVE "CHO OK HWA" IS "CHO OK HWA", WHICH IS THE NAME OF APPLICANT'S MOTHER. THE TRANSLITERATION OF THE NON-LATIN CHARACTERS ABOVE "ANDONG SOJU" IS "ANDONG SOJU" AND THIS MEANS THE TRADITIONAL MANUFACTURING PROCESS FOR "ANDONG SOJU".

FOR BUPJU, NAMELY, KOREAN TRADITIONAL RICE WINE; SOJU, NAMELY, KOREAN LIQUEURS DISTILLED OR DILUTED; RICE ALCOHOL, NAMELY, DISTILLED SPIRITS OF RICE; YAK-JU, NAMELY, REFINED RICE WINE; DISTILLED LIQUEUR FROM GINSENG; SAKE; TAK-JU, NAMELY, UNSTRAINED RICE WINE; COMPOUND CLEAR RICE WINE; STRAWBERRY WINE; RUM; LIQUEURS; TONIC LIQUOR FLAVORED WITH PLUM EXTRACTS; WILD GRAPES WINE; EFFERVESCING FRUIT WINE; EFFERVESCING WINE; PERRY; KIRSCH; VERMOUTH; VODKA; BRANDY; ALCOHOLIC BITTERS; HARD CIDER; CHAMPAGNE; SWEET WINE; TABLE WINE; ANISE LIQUEUR; APERITIFS; APERITIFS WITH A DISTILLED ALCOHOLIC LIQUOR BASE; ALCOHOLIC FRUIT EXTRACTS; ALCOHOLIC ESSENCES FOR MAKING FRUIT WINE; ALCOHOLIC EXTRACTS; ALCOHOLIC BEVERAGES CONTAINING FRUIT; ABSINTHE LIQUEUR; WINE COOLER DRINKS; ALCOHOLIC COCKTAIL CONTAINING MILK; WHISKY; CITRON WINE; DISTILLED SPIRITS; GIN; NATURAL EFFERVESCING WINE; PREPARED WINE COCKTAILS; ALCOHOLIC COFFEE-BASED BEVERAGES; CURACAO; WINE; GAOLIAN-JIOU, NAMELY, CHINESE ALCOHOLIC SPIRIT OF SORGHUM; PEPPERMINT LIQUEURS; HYDROMEL MEAD; TONIC LIQUOR CONTAINING HERB EXTRACTS; TONIC LIQUOR FLAVORED WITH PINE NEEDLE EXTRACTS; ACANTHOPANAX WINE, NAMELY, CHINESE LIQUEURS; BAIGANR, NAMELY, CHINESE WHITE LIQUOR; LAOJIOU, NAMELY, CHINESE BREWED LIQUOR (U.S. CLS. 47 AND 49).

LINDA ESTRADA, EXAMINING ATTORNEY

**CLASS 33—(Continued).**

SN 85-031,148. MICHAEL-DAVID, LLC, LODI, CA. FILED 5-5-2010.

**SEVEN HEAVENLY**

THE MARK CONSISTS OF STANDARD CHARACTERS WITHOUT CLAIM TO ANY PARTICULAR FONT, STYLE, SIZE, OR COLOR.

OWNER OF U.S. REG. NOS. 2,872,688 AND 2,883,054. FOR WINE (U.S. CLS. 47 AND 49). FIRST USE 1-1-2010; IN COMMERCE 1-1-2010. MICHAEL TANNER, EXAMINING ATTORNEY

SN 85-038,827. FALUA-SOCIEDADE DE VINHOS, S.A., ALMEIRIM, PORTUGAL, FILED 5-14-2010.

**FALUA**

THE MARK CONSISTS OF STANDARD CHARACTERS WITHOUT CLAIM TO ANY PARTICULAR FONT, STYLE, SIZE, OR COLOR.

OWNER OF PORTUGAL REG. NO. 274285, DATED 4-23-1993, EXPIRES 4-23-2013.

THE WORDING "FALUA" HAS NO MEANING IN A FOREIGN LANGUAGE.

FOR WINES (U.S. CLS. 47 AND 49). ANDREA HACK, EXAMINING ATTORNEY

SN 85-044,038. FOXWAY COMPANY, TA SILVERPAIL DAIRY, FERMOY, CO. CORK, IRELAND, FILED 5-20-2010.

**CREMOR**

THE MARK CONSISTS OF STANDARD CHARACTERS WITHOUT CLAIM TO ANY PARTICULAR FONT, STYLE, SIZE, OR COLOR.

PRIORITY CLAIMED UNDER SEC. 44(D) ON ERPNTY TM OFC APPLICATION NO. 009092123, FILED 5-10-2010, REG. NO. 009092123, DATED 9-27-2010, EXPIRES 5-10-2020.

FOR ALCOHOLIC BEVERAGES EXCEPT BEERS; ALCOHOLIC WINES; SPIRITS AND LIQUEURS; ALCOHOLIC COCKTAIL MIXES (U.S. CLS. 47 AND 49).

RAUL CORDOVA, EXAMINING ATTORNEY

**CLASS 33—(Continued).**

SN 85-053,061. JWB WINE LLC, DBA BRAMAN WINERY, VICTORIA, TX. FILED 6-2-2010.



THE NAME SHOWN IN THE MARK DOES NOT IDENTIFY A PARTICULAR LIVING INDIVIDUAL.

THE MARK CONSISTS OF A STYLIZED SHIELD-LIKE DESIGN WITH THE STYLIZED WORDS AND LETTERS "JB BRAMAN LEGACY" WITHIN THE SHIELD.

FOR WINE (U.S. CLS. 47 AND 49).

EMILY CHUO, EXAMINING ATTORNEY

SN 85-057,998. KATZ, STEVEN, POMPANO BEACH, FL. AND GIRAUD, CECILE, POMPANO BEACH, FL. FILED 6-9-2010.

## ZAZO

THE MARK CONSISTS OF STANDARD CHARACTERS WITHOUT CLAIM TO ANY PARTICULAR FONT, STYLE, SIZE, OR COLOR.

FOR WINE (U.S. CLS. 47 AND 49).

KAPIL BHANOT, EXAMINING ATTORNEY

SN 85-076,627. LA RURAL VIÑEDOS Y BODEGAS, S.A. LTDA., MENDOZA, ARGENTINA, FILED 7-1-2010.

## TORNEO

THE MARK CONSISTS OF STANDARD CHARACTERS WITHOUT CLAIM TO ANY PARTICULAR FONT, STYLE, SIZE, OR COLOR.

THE ENGLISH TRANSLATION OF "TORNEO" IN THE MARK IS "TOURNAMENT".

FOR TABLE WINES (U.S. CLS. 47 AND 49).

ADA HAN, EXAMINING ATTORNEY

**CLASS 33—(Continued).**

SN 85-095,167. ENDEAVOR VINEYARDS PTY LTD, ABBOTSFORD, VICTORIA, AUSTRALIA, FILED 7-28-2010.



NO CLAIM IS MADE TO THE EXCLUSIVE RIGHT TO USE "MARLBOROUGH NEW ZEALAND", APART FROM THE MARK AS SHOWN.

THE MARK CONSISTS OF THE WORDS "CATALINA SOUNDS" WITH AN IMAGE OF LAND AND AN AIRPLANE SURROUNDED BY WATER AND THE WORDS "MARLBOROUGH NEW ZEALAND".

FOR WINE (U.S. CLS. 47 AND 49).

FIRST USE 10-0-2007; IN COMMERCE 10-0-2007.

ANGELA DUONG, EXAMINING ATTORNEY

SN 85-125,635. WILLIAM GRANT & SONS LIMITED, BANFFSHIRE, SCOTLAND, UNITED KINGDOM, FILED 9-9-2010.

## GLENFIDDICH

THE MARK CONSISTS OF STANDARD CHARACTERS WITHOUT CLAIM TO ANY PARTICULAR FONT, STYLE, SIZE, OR COLOR.

OWNER OF U.S. REG. NOS. 949,472, 2,799,726 AND OTHERS.

THE ENGLISH TRANSLATION OF THE WORD "GLENFIDDICH" IN THE MARK IS "VALLEY OF THE DEER".

FOR ALCOHOLIC BEVERAGES EXCEPT BEERS (U.S. CLS. 47 AND 49).

FIRST USE 12-0-1887; IN COMMERCE 6-0-1935.

ARETHA SOMERVILLE, EXAMINING ATTORNEY

SN 85-130,975. PIRANHA, DUBLIN, IRELAND, FILED 9-16-2010.

## JACK RYAN

THE MARK CONSISTS OF STANDARD CHARACTERS WITHOUT CLAIM TO ANY PARTICULAR FONT, STYLE, SIZE, OR COLOR.

THE NAME "JACK RYAN" DOES NOT IDENTIFY A LIVING INDIVIDUAL.

FOR WHISKEY (U.S. CLS. 47 AND 49).

RONALD MCMORROW, EXAMINING ATTORNEY

**CLASS 33—(Continued).**

SN 85-131,214. SOUTHCORP BRANDS PTY LIMITED, SOUTHBANK, VICTORIA, AUSTRALIA, FILED 9-16-2010.



PRIORITY CLAIMED UNDER SEC. 44(D) ON AUSTRALIA APPLICATION NO. 1352334, FILED 3-24-2010, REG. NO. 1352334, DATED 3-24-2010, EXPIRES 3-24-2020.

THE MARK CONSISTS OF AN IRREGULAR RECTANGLE WITH THE TOP HALF BEING SHADED. THE CAPITAL LETTER "E" APPEARS IN THE SHADED PORTION, BELOW IS AN "&" SYMBOL. THE CAPITAL LETTER "C" APPEARS BELOW THE LETTER "E" AND THE "&" SYMBOL. IN THE UPPER RIGHT CORNER OF THE IRREGULAR RECTANGLE SHAPE ARE THE SMALL STYLIZED LETTERS "EC". IN THE BOTTOM LEFT CORNER OF THE IRREGULAR RECTANGLE SHAPE IS THE WORDING "EDWARDS & CHAFFEY".

FOR WINE (U.S. CLS. 47 AND 49).

JESSICA FATHY, EXAMINING ATTORNEY

**CLASS 33—(Continued).**

SN 85-134,379. HAZLITT 1852 VINEYARDS, INC., HECTOR, NY. FILED 9-21-2010.

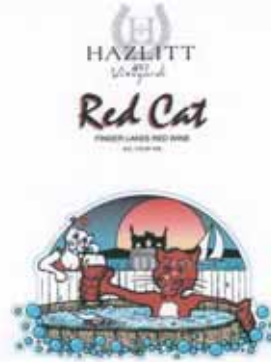

OWNER OF U.S. REG. NOS. 2,247,850, 3,840,560 AND 3,840,562.

NO CLAIM IS MADE TO THE EXCLUSIVE RIGHT TO USE "1852 VINEYARDS FINGER LAKES RED WINE ALC. 11% BY VOL.", APART FROM THE MARK AS SHOWN.

THE COLOR(S) RED, WHITE, BLACK, TAN, GRAY, AND BLUE IS/ARE CLAIMED AS A FEATURE OF THE MARK.

THE MARK CONSISTS OF THE WORDS "HAZLITT 1852 VINEYARDS FINGER LAKES RED WINE, ALC. 11% BY VOL." APPEARING IN BLACK AND THE WORDS "RED CAT" APPEARING IN RED AND BLACK, BLUE SKY, BLACK LAND, RED AND TAN SETTING SUN, BLACK SILHOUETTES OF CATS ON A GRAY TRASH CAN WHITE SAIL BOAT ON BLUE WATER, WHITE CAT IN A RED DRESS, WITH BLUE EYES AND RED HEARTS ABOVE HER HEAD LEANING ON A WHITE FENCE LOOKING AT A RED (WITH WHITE AND BLACK) CAT, SOAKING IN A TAN HOT TUB FILLED WITH BLUE WATER, A FLOATING RED, WHITE AND BLACK WINE BOTTLE WITH A TAN CORK, DRINKING A GLASS OF RED WINE, AND BLUE BUBBLES AT THE BOTTOM OF THE DRAWING.

FOR WINES (U.S. CLS. 47 AND 49).

FIRST USE 8-23-2005; IN COMMERCE 8-23-2005.

FLORENTINA BLANDU, EXAMINING ATTORNEY

SN 85-134,374. K2 SPIRITS IMPORTERS LLC, NEW YORK, NY. FILED 9-21-2010.

**K2 vodka**

THE MARK CONSISTS OF STANDARD CHARACTERS WITHOUT CLAIM TO ANY PARTICULAR FONT, STYLE, SIZE, OR COLOR.

NO CLAIM IS MADE TO THE EXCLUSIVE RIGHT TO USE "VODKA", APART FROM THE MARK AS SHOWN. FOR VODKA (U.S. CLS. 47 AND 49).

MATTHEW MCDOWELL, EXAMINING ATTORNEY

SN 85-140,426. PRETTY FLUFFY CHICKEN PRODUCTIONS, LLC, EDINA, MN. FILED 9-28-2010.

**EAT YOUR DRINK**

THE MARK CONSISTS OF STANDARD CHARACTERS WITHOUT CLAIM TO ANY PARTICULAR FONT, STYLE, SIZE, OR COLOR.

NO CLAIM IS MADE TO THE EXCLUSIVE RIGHT TO USE "DRINK", APART FROM THE MARK AS SHOWN.

FOR FLAVORED AND SWEETENED GELATIN SHOOTERS CONTAINING ALCOHOL; ALCOHOLIC COCKTAIL MIXES (U.S. CLS. 47 AND 49).

WON TEAK OH, EXAMINING ATTORNEY

**CLASS 33—(Continued).**

SN 85-147,036. HORACIO MANUEL CARTES JARA, ASUN-  
CION, PARAGUAY, FILED 10-7-2010.

## ESTRELLA GOLD

THE MARK CONSISTS OF STANDARD CHARACTERS  
WITHOUT CLAIM TO ANY PARTICULAR FONT, STYLE,  
SIZE, OR COLOR.

NO CLAIM IS MADE TO THE EXCLUSIVE RIGHT TO  
USE "GOLD", APART FROM THE MARK AS SHOWN.

THE ENGLISH TRANSLATION OF "ESTRELLA" IN THE  
MARK IS "STAR".

FOR LIQUOR, NAMELY, A RUM (U.S. CLS. 47 AND  
49).

BENJAMIN OKEKE, EXAMINING ATTORNEY

**CLASS 33—(Continued).**

SN 85-150,422. DESERT DIAMOND DISTILLERY INC.,  
KINGMAN, AZ. FILED 10-12-2010.



NO CLAIM IS MADE TO THE EXCLUSIVE RIGHT TO  
USE "DISTILLERY", APART FROM THE MARK AS  
SHOWN.

THE MARK CONSISTS OF A RIBBON ON THE LEFT  
AND RIGHT SIDE OF A CIRCLE. THE INSIDE OF THE  
CIRCLE SAYS "D3". UNDERNEATH THE RIBBON AND  
CIRCLE ARE THE WORDS "DESERT DIAMOND DISTIL-  
LERY".

FOR DISTILLED SPIRITS (U.S. CLS. 47 AND 49).

FIRST USE 4-1-2010; IN COMMERCE 4-1-2010.

MICHAEL WIENER, EXAMINING ATTORNEY

SN 85-147,902. SPRING 44 DISTILLING, LLC, DENVER, CO.  
FILED 10-7-2010.

## Spring44

THE MARK CONSISTS OF STANDARD CHARACTERS  
WITHOUT CLAIM TO ANY PARTICULAR FONT, STYLE,  
SIZE, OR COLOR.

FOR ALCOHOLIC BEVERAGES, NAMELY, VODKA  
AND GIN (U.S. CLS. 47 AND 49).

ELIZABETH KAJUBI, EXAMINING ATTORNEY

SN 85-152,071. ST. FRANCIS WINERY & VINEYARDS, LP,  
SANTA ROSA, CA. FILED 10-13-2010.

## BEHLER

THE MARK CONSISTS OF STANDARD CHARACTERS  
WITHOUT CLAIM TO ANY PARTICULAR FONT, STYLE,  
SIZE, OR COLOR.

SEC. 2(F).

FOR WINES (U.S. CLS. 47 AND 49).

FIRST USE 9-1-2003; IN COMMERCE 9-1-2003.

GEOFFREY FOSDICK, EXAMINING ATTORNEY

SN 85-147,912. SPRING 44 DISTILLING, LLC, DENVER, CO.  
FILED 10-7-2010.

## SPRING44

THE MARK CONSISTS OF "SPRING44" IN STYLIZED  
FONT.

FOR ALCOHOLIC BEVERAGES, NAMELY, VODKA  
AND GIN (U.S. CLS. 47 AND 49).

ELIZABETH KAJUBI, EXAMINING ATTORNEY

SN 85-156,266. KANBAR, DAVID A, NEW YORK, NY. FILED  
10-19-2010.

## Tzedakah

THE MARK CONSISTS OF STANDARD CHARACTERS  
WITHOUT CLAIM TO ANY PARTICULAR FONT, STYLE,  
SIZE, OR COLOR.

THE ENGLISH TRANSLATION OF THE WORD "TZEDA-  
KAH" IN THE MARK IS "CHARITY".

FOR WINE (U.S. CLS. 47 AND 49).

JAMES LOVELACE, EXAMINING ATTORNEY

**CLASS 33—(Continued).**

SN 85-156,617. DEPARTMENT 28, INC, PALATINE, IL.  
FILED 10-20-2010.

**EMPERADOR VODKA**

THE MARK CONSISTS OF STANDARD CHARACTERS WITHOUT CLAIM TO ANY PARTICULAR FONT, STYLE, SIZE, OR COLOR.

NO CLAIM IS MADE TO THE EXCLUSIVE RIGHT TO USE "VODKA", APART FROM THE MARK AS SHOWN.

THE ENGLISH TRANSLATION OF THE WORD "EMPERADOR" IN THE MARK IS "EMPEROR".

FOR ALCOHOLIC BEVERAGES, NAMELY, VODKA (U.S. CLS. 47 AND 49).

KEVIN DINALLO, EXAMINING ATTORNEY

---

SN 85-157,441. SUTTER HOME WINERY, INC., ST. HELENA, CA. FILED 10-20-2010.

**SUTTER HOME**

THE MARK CONSISTS OF STANDARD CHARACTERS WITHOUT CLAIM TO ANY PARTICULAR FONT, STYLE, SIZE, OR COLOR.

OWNER OF U.S. REG. NOS. 1,385,404, 1,774,736 AND 3,182,910.

FOR ALCOHOLIC BEVERAGES EXCEPT BEERS (U.S. CLS. 47 AND 49).

FIRST USE 0-0-1900; IN COMMERCE 0-0-1972.

JAY BESCH, EXAMINING ATTORNEY

---

SN 85-157,641. DEPARTMENT 28, INC, PALATINE, IL.  
FILED 10-21-2010.

**EMPRESS VODKA**

THE MARK CONSISTS OF STANDARD CHARACTERS WITHOUT CLAIM TO ANY PARTICULAR FONT, STYLE, SIZE, OR COLOR.

NO CLAIM IS MADE TO THE EXCLUSIVE RIGHT TO USE "VODKA", APART FROM THE MARK AS SHOWN.

FOR ALCOHOLIC BEVERAGES, NAMELY, VODKA (U.S. CLS. 47 AND 49).

KEVIN DINALLO, EXAMINING ATTORNEY

**CLASS 33—(Continued).**

SN 85-158,261. SAZERAC COMPANY, INC., NEW ORLEANS, LA. FILED 10-21-2010.

**JOHN J. BOWMAN**

THE MARK CONSISTS OF STANDARD CHARACTERS WITHOUT CLAIM TO ANY PARTICULAR FONT, STYLE, SIZE, OR COLOR.

OWNER OF U.S. REG. NO. 2,062,499.

THE NAME(S), PORTRAIT(S), AND/OR SIGNATURE(S) SHOWN IN THE MARK DOES NOT IDENTIFY A PARTICULAR LIVING INDIVIDUAL.

FOR WHISKEY (U.S. CLS. 47 AND 49).

FIRST USE 12-0-2009; IN COMMERCE 12-0-2009.

ELISSA GARBER KON, EXAMINING ATTORNEY

---

SN 85-158,650. DEPARTMENT 28, INC, PALATINE, IL.  
FILED 10-22-2010.

**NOBLE CREST VODKA**

THE MARK CONSISTS OF STANDARD CHARACTERS WITHOUT CLAIM TO ANY PARTICULAR FONT, STYLE, SIZE, OR COLOR.

NO CLAIM IS MADE TO THE EXCLUSIVE RIGHT TO USE "VODKA", APART FROM THE MARK AS SHOWN.

FOR ALCOHOLIC BEVERAGES, NAMELY, VODKA (U.S. CLS. 47 AND 49).

KEVIN DINALLO, EXAMINING ATTORNEY

**CLASS 33—(Continued).**

SN 85-159,309. CIA. MONTERROSAS, S.A. DE C.V., TEHUACAN, PUEBLA, MEXICO, FILED 10-22-2010.



OWNER OF U.S. REG. NO. 3,887,615.  
NO CLAIM IS MADE TO THE EXCLUSIVE RIGHT TO USE "WHITE MEZCAL", APART FROM THE MARK AS SHOWN.

THE COLOR(S) TEAL, BROWN, WHITE, YELLOW, AND DARK BLUE IS/ARE CLAIMED AS A FEATURE OF THE MARK.

THE MARK CONSISTS OF THE WORDING "MEXCALIA WHITE MEZCAL" APPEARING IN WHITE AND DARK BLUE APPEARING ABOVE THE OUTLINE OF A DARK BLUE PLANT WHICH APPEARS BELOW THE YELLOW DESIGN OF A TIGER FACE WITH DARK BLUE OUTLINING, ALL AGAINST A TEAL BACKGROUND WITH A BROWN AND TEAL BORDER.

THE WORDING "MEXCALIA" HAS NO MEANING IN A FOREIGN LANGUAGE.

FOR MEZCAL (U.S. CLS. 47 AND 49).  
FIRST USE 11-19-2009; IN COMMERCE 11-19-2009.  
CHRISTINE MARTIN, EXAMINING ATTORNEY

SN 85-159,316. INDUSTRIALIZADORA RICTUS S.A DE C.V., GUADALAJARA JALISCO, MEXICO, FILED 10-22-2010.

# RICTUS

THE MARK CONSISTS OF STANDARD CHARACTERS WITHOUT CLAIM TO ANY PARTICULAR FONT, STYLE, SIZE, OR COLOR.

THE WORDING "RICTUS" HAS NO MEANING IN A FOREIGN LANGUAGE.

FOR ALCOHOLIC BEVERAGES EXCEPT BEERS, ALCOHOLIC BEVERAGES MADE FROM AGAVE, AGAVE BASED ALCOHOLIC BEVERAGES, ALCOHOLIC BEVERAGES INCORPORATING AGAVE, TEQUILA (U.S. CLS. 47 AND 49).

GRETTA YAO, EXAMINING ATTORNEY

**CLASS 33—(Continued).**

SN 85-168,089. GOLDEN FORTUNE IMPORT & EXPORT CROP., BAYONNE, NJ. FILED 11-3-2010.



THE MARK CONSISTS OF A DRAWING OF A PAGODA WITH A COIN ON THE TIP TOP, TWO NON-LATIN CHARACTERS ON BOTH SIDES OF THE PAGODA AND THE WORDING "RICH PAGODA" ON THE BOTTOM OF THE PAGODA.

TWO NON-LATIN CHARACTERS TRANSLITERATE TO "FU" AND "TA" AND THESE MEAN "RICH" AND "PAGODA".

FOR COOKING WINE (U.S. CLS. 47 AND 49).  
FIRST USE 7-2-2010; IN COMMERCE 7-2-2010.  
ARETHA SOMERVILLE, EXAMINING ATTORNEY

SN 85-172,631. BOOMERANG BRANDS LLC, WESTMONT, IL. FILED 11-9-2010.

# SIMPLY SERVE

THE MARK CONSISTS OF STANDARD CHARACTERS WITHOUT CLAIM TO ANY PARTICULAR FONT, STYLE, SIZE, OR COLOR.

FOR ALCOHOLIC MIXED BEVERAGES EXCEPT BEERS (U.S. CLS. 47 AND 49).

MEGHAN REINHART, EXAMINING ATTORNEY

SN 85-172,698. CRISTALL U.S.A., INC., BOCA RATON, FL. FILED 11-9-2010.

# KRISTALL

THE MARK CONSISTS OF STANDARD CHARACTERS WITHOUT CLAIM TO ANY PARTICULAR FONT, STYLE, SIZE, OR COLOR.

OWNER OF U.S. REG. NOS. 2,336,937, 3,646,945 AND OTHERS.

THE ENGLISH TRANSLATION OF "KRISTALL" IN THE MARK IS "CRYSTAL".

FOR VODKA (U.S. CLS. 47 AND 49).  
DAWN HAN, EXAMINING ATTORNEY

**CLASS 33—(Continued).**

SN 85-173,164. PURE FOLIE S.A.R.L., PESSAC, FRANCE, FILED 11-10-2010.

PURE  
FOLIE

THE COLOR(S) DARK GREY AND WHITE IS/ARE CLAIMED AS A FEATURE OF THE MARK.  
THE MARK CONSISTS OF STYLIZED DARK GREY WRITING ON WHITE BACKGROUND.  
FOR SPIRITS AND LIQUEURS (U.S. CLS. 47 AND 49).  
FIRST USE 6-22-2010; IN COMMERCE 6-22-2010.  
CHERYL CLAYTON, EXAMINING ATTORNEY

SN 85-174,999. BS2 INTERNATIONAL, LLC, PORTLAND, OR. FILED 11-11-2010.

St. Bartholomew

THE MARK CONSISTS OF STANDARD CHARACTERS WITHOUT CLAIM TO ANY PARTICULAR FONT, STYLE, SIZE, OR COLOR.  
FOR WINE (U.S. CLS. 47 AND 49).  
FIRST USE 10-14-2008; IN COMMERCE 10-14-2008.  
WILLIAM ROSSMAN, EXAMINING ATTORNEY

SN 85-176,026. PL360 BEVERAGE PARTNERS, LLC, DENVER, CO. FILED 11-12-2010.

BOX OF LETTERS

THE MARK CONSISTS OF STANDARD CHARACTERS WITHOUT CLAIM TO ANY PARTICULAR FONT, STYLE, SIZE, OR COLOR.  
FOR WINES (U.S. CLS. 47 AND 49).  
DOMINIC J. FERRAIUOLO, EXAMINING ATTORNEY

**CLASS 33—(Continued).**

SN 85-176,032. PL360 BEVERAGE PARTNERS, LLC, DENVER, CO. FILED 11-12-2010.

GREENVILLE ROAD

THE MARK CONSISTS OF STANDARD CHARACTERS WITHOUT CLAIM TO ANY PARTICULAR FONT, STYLE, SIZE, OR COLOR.  
FOR WINES (U.S. CLS. 47 AND 49).  
DOMINIC J. FERRAIUOLO, EXAMINING ATTORNEY

SN 85-176,173. TROMBA CANADA LTD., TORONTO, CANADA, FILED 11-13-2010.

TROMBA

THE MARK CONSISTS OF STANDARD CHARACTERS WITHOUT CLAIM TO ANY PARTICULAR FONT, STYLE, SIZE, OR COLOR.  
THE ENGLISH TRANSLATION OF "TROMBA" IN THE MARK IS "WHIRLWIND".  
FOR TEQUILA (U.S. CLS. 47 AND 49).  
DEBRA LEE, EXAMINING ATTORNEY

SN 85-176,185. JACOB BECKETT, PASO ROBLES, CA. FILED 11-13-2010.



THE MARK CONSISTS OF A SKULL WITH A FULL WINE GLASS SUPERIMPOSED ON THE FOREHEAD OF THE SKULL.  
FOR WINE (U.S. CLS. 47 AND 49).  
FIRST USE 7-26-2008; IN COMMERCE 7-26-2008.  
MATTHEW PAPPAS, EXAMINING ATTORNEY



**CLASS 33—(Continued).**

SN 85-176,186. JACOB BECKETT, PASO ROBLES, CA. FILED 11-13-2010.

# Stone Fox

THE MARK CONSISTS OF STANDARD CHARACTERS WITHOUT CLAIM TO ANY PARTICULAR FONT, STYLE, SIZE, OR COLOR.

FOR WINE (U.S. CLS. 47 AND 49).  
FIRST USE 7-17-2010; IN COMMERCE 7-17-2010.  
MATTHEW PAPPAS, EXAMINING ATTORNEY

**CLASS 33—(Continued).**

SN 85-176,447. FREDERICK WILDMAN & SONS, LTD, NEW YORK, NY. FILED 11-15-2010.

# ZEBO

THE MARK CONSISTS OF STANDARD CHARACTERS WITHOUT CLAIM TO ANY PARTICULAR FONT, STYLE, SIZE, OR COLOR.

FOR WINES AND SPARKLING WINES (U.S. CLS. 47 AND 49).  
GEORGE LORENZO, EXAMINING ATTORNEY

SN 85-176,188. JACOB BECKETT, PASO ROBLES, CA. FILED 11-13-2010.

# Suite Petite

THE MARK CONSISTS OF STANDARD CHARACTERS WITHOUT CLAIM TO ANY PARTICULAR FONT, STYLE, SIZE, OR COLOR.

FOR WINE (U.S. CLS. 47 AND 49).  
FIRST USE 1-9-2010; IN COMMERCE 1-9-2010.  
MATTHEW PAPPAS, EXAMINING ATTORNEY

SN 85-176,782. DON SEBASTIANI & SONS INTERNATIONAL WINE NEGOCIANTS, SONOMA, CA. FILED 11-15-2010.

# SIVAS - SONOMA

THE MARK CONSISTS OF STANDARD CHARACTERS WITHOUT CLAIM TO ANY PARTICULAR FONT, STYLE, SIZE, OR COLOR.

FOR WINE (U.S. CLS. 47 AND 49).  
BARNEY CHARLON, EXAMINING ATTORNEY

SN 85-176,189. JACOB BECKETT, PASO ROBLES, CA. FILED 11-13-2010.

# dead nuts

THE MARK CONSISTS OF STANDARD CHARACTERS WITHOUT CLAIM TO ANY PARTICULAR FONT, STYLE, SIZE, OR COLOR.

FOR WINE (U.S. CLS. 47 AND 49).  
FIRST USE 1-9-2010; IN COMMERCE 1-9-2010.  
MATTHEW PAPPAS, EXAMINING ATTORNEY

SN 85-177,074. NORTH COAST VINEYARD SERVICES INC., CLOVERDALE, CA. FILED 11-15-2010.

# JOSEPH HENRY WINE

THE MARK CONSISTS OF STANDARD CHARACTERS WITHOUT CLAIM TO ANY PARTICULAR FONT, STYLE, SIZE, OR COLOR.

NO CLAIM IS MADE TO THE EXCLUSIVE RIGHT TO USE "WINE", APART FROM THE MARK AS SHOWN.

THE NAME(S), PORTRAIT(S), AND/OR SIGNATURE(S) SHOWN IN THE MARK DOES NOT IDENTIFY A PARTICULAR LIVING INDIVIDUAL.

FOR WINE (U.S. CLS. 47 AND 49).  
REBECCA EISINGER, EXAMINING ATTORNEY

**CLASS 33—(Continued).**

SN 85-177,167. WOODWARD CANYON WINERY, INC.,  
LOWDEN, WA. FILED 11-15-2010.

**NELMS ROAD**

THE MARK CONSISTS OF STANDARD CHARACTERS  
WITHOUT CLAIM TO ANY PARTICULAR FONT, STYLE,  
SIZE, OR COLOR.

FOR WINE (U.S. CLS. 47 AND 49).  
FIRST USE 11-11-1999; IN COMMERCE 11-11-1999.  
YAT SYE, LEE, EXAMINING ATTORNEY

SN 85-178,064. PREMIUM WINE BRANDS PTY LTD, DUL-  
WICH SA 5065, AUSTRALIA, FILED 11-16-2010.

**COOL HARVEST**

THE MARK CONSISTS OF STANDARD CHARACTERS  
WITHOUT CLAIM TO ANY PARTICULAR FONT, STYLE,  
SIZE, OR COLOR.

FOR WINES (U.S. CLS. 47 AND 49).  
YAT SYE, LEE, EXAMINING ATTORNEY

SN 85-178,072. PREMIUM WINE BRANDS PTY LTD, DUL-  
WICH SA 5065, AUSTRALIA, FILED 11-16-2010.

**SPLENDEROSA**

THE MARK CONSISTS OF STANDARD CHARACTERS  
WITHOUT CLAIM TO ANY PARTICULAR FONT, STYLE,  
SIZE, OR COLOR.

FOR WINES (U.S. CLS. 47 AND 49).  
YAT SYE, LEE, EXAMINING ATTORNEY

SN 85-178,266. MISSISSIPPI RIVER DISTILLING COMPANY,  
LECLAIRE, IA. FILED 11-16-2010.

**RIVER ROSE**

THE MARK CONSISTS OF STANDARD CHARACTERS  
WITHOUT CLAIM TO ANY PARTICULAR FONT, STYLE,  
SIZE, OR COLOR.

FOR DISTILLED SPIRITS; GIN (U.S. CLS. 47 AND 49).  
ARETHA SOMERVILLE, EXAMINING ATTORNEY

**CLASS 33—(Continued).**

SN 85-179,190. POPCORN DESIGN, LLC, HEALDSBURG,  
CA. FILED 11-17-2010.

**Roller Skates**

THE MARK CONSISTS OF STANDARD CHARACTERS  
WITHOUT CLAIM TO ANY PARTICULAR FONT, STYLE,  
SIZE, OR COLOR.

FOR WINES (U.S. CLS. 47 AND 49).  
FRED CARL, EXAMINING ATTORNEY

SN 85-179,520. SANCHEZ, DAVID M., SAN JOSE, CA. FILED  
11-17-2010.

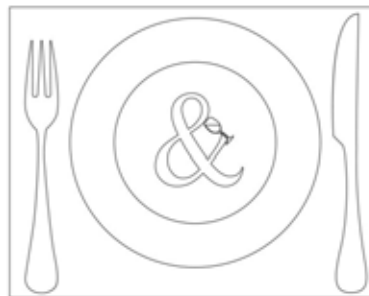

THE MARK CONSISTS OF PLACE SETTING WITH AND  
AMPERSAND DRINKING A GLASS OF WINE.

FOR RED WINE; WHITE WINE; WINE (U.S. CLS. 47  
AND 49).

MARK RADEMACHER, EXAMINING ATTORNEY

SN 85-179,590. THE MILLIONE FOUNDATION LIMITED,  
LONDON, UNITED KINGDOM, FILED 11-18-2010.

**ONE IN A MILLIONE**

THE MARK CONSISTS OF STANDARD CHARACTERS  
WITHOUT CLAIM TO ANY PARTICULAR FONT, STYLE,  
SIZE, OR COLOR.

THE ENGLISH TRANSLATION OF "MILLIONE" IN THE  
MARK IS "MILLION".

FOR WINE (U.S. CLS. 47 AND 49).

AISHA SALEM, EXAMINING ATTORNEY

**CLASS 33—(Continued).**

SN 85-179,669. BAKER, JENNA, PLEASANTVILLE, NJ. FILED 11-18-2010.

**2RED**

THE MARK CONSISTS OF STANDARD CHARACTERS WITHOUT CLAIM TO ANY PARTICULAR FONT, STYLE, SIZE, OR COLOR.  
FOR ALCOHOLIC BEVERAGES EXCEPT BEERS (U.S. CLS. 47 AND 49).  
RICHARD WHITE, EXAMINING ATTORNEY

SN 85-179,778. LEOPARD'S LEAP WINES (PTY) LIMITED, FRANSCHHOEK, SOUTH AFRICA, FILED 11-18-2010.

**LION'S LAND**

THE MARK CONSISTS OF STANDARD CHARACTERS WITHOUT CLAIM TO ANY PARTICULAR FONT, STYLE, SIZE, OR COLOR.  
OWNER OF SOUTH AFRICA REG. NO. 2006/01395, DATED 1-23-2006, EXPIRES 1-23-2016.  
FOR WINES (U.S. CLS. 47 AND 49).  
FRANK LATTUCA, EXAMINING ATTORNEY

SN 85-180,503. BLUEROCK VINEYARD, LLC, TIBURON, CA. FILED 11-18-2010.

**BEST BARRELS**

THE MARK CONSISTS OF STANDARD CHARACTERS WITHOUT CLAIM TO ANY PARTICULAR FONT, STYLE, SIZE, OR COLOR.  
SEC. 2(F).  
FOR ALCOHOLIC BEVERAGES EXCEPT BEERS (U.S. CLS. 47 AND 49).  
FIRST USE 4-11-2006; IN COMMERCE 4-11-2006.  
KAREN K. BUSH, EXAMINING ATTORNEY

**CLASS 33—(Continued).**

SN 85-181,168. THE WINE GROUP LLC, TRACY, CA. FILED 11-19-2010.

**FINESSE**

THE MARK CONSISTS OF STANDARD CHARACTERS WITHOUT CLAIM TO ANY PARTICULAR FONT, STYLE, SIZE, OR COLOR.  
OWNER OF U.S. REG. NO. 2,918,027.  
FOR WINE (U.S. CLS. 47 AND 49).  
LINDA POWELL, EXAMINING ATTORNEY

SN 85-181,346. E. & J. GALLO WINERY, MODESTO, CA. FILED 11-19-2010.

**OWN IT**

THE MARK CONSISTS OF STANDARD CHARACTERS WITHOUT CLAIM TO ANY PARTICULAR FONT, STYLE, SIZE, OR COLOR.  
FOR WINES (U.S. CLS. 47 AND 49).  
TARA PATE, EXAMINING ATTORNEY

SN 85-187,260. E. & J. GALLO WINERY, MODESTO, CA. FILED 11-30-2010.

**OWN IT. BE IT. SELL IT.  
WORK IT. FLAUNT IT. TRUST IT.**

THE MARK CONSISTS OF STANDARD CHARACTERS WITHOUT CLAIM TO ANY PARTICULAR FONT, STYLE, SIZE, OR COLOR.  
FOR WINES (U.S. CLS. 47 AND 49).  
TARA PATE, EXAMINING ATTORNEY

SN 85-199,769. E. & J. GALLO WINERY, MODESTO, CA. FILED 12-16-2010.

**NEPTUNUS REX**

THE MARK CONSISTS OF STANDARD CHARACTERS WITHOUT CLAIM TO ANY PARTICULAR FONT, STYLE, SIZE, OR COLOR.  
FOR RUM (U.S. CLS. 47 AND 49).  
TARA PATE, EXAMINING ATTORNEY

**CLASS 33—(Continued).**

SN 85-206,133. L&P SPIRITS IMPORTS, LLC, SAN FRANCISCO, CA. FILED 12-27-2010.

**SERPENTINE GIN**

THE MARK CONSISTS OF STANDARD CHARACTERS WITHOUT CLAIM TO ANY PARTICULAR FONT, STYLE, SIZE, OR COLOR.

NO CLAIM IS MADE TO THE EXCLUSIVE RIGHT TO USE "GIN", APART FROM THE MARK AS SHOWN.  
FOR DISTILLED SPIRITS; GIN (U.S. CLS. 47 AND 49).  
FRED CARL, EXAMINING ATTORNEY

SN 85-206,644. NORTH COAST VINEYARD SERVICES INC., CLOVERDALE, CA. FILED 12-28-2010.

**RED BERYL VINEYARDS**

THE MARK CONSISTS OF STANDARD CHARACTERS WITHOUT CLAIM TO ANY PARTICULAR FONT, STYLE, SIZE, OR COLOR.

NO CLAIM IS MADE TO THE EXCLUSIVE RIGHT TO USE "VINEYARDS", APART FROM THE MARK AS SHOWN.  
FOR WINE (U.S. CLS. 47 AND 49).  
REBECCA EISINGER, EXAMINING ATTORNEY

SN 85-210,270. PURPLE WINE PRODUCTION COMPANY, GRATON, CA. FILED 1-4-2011.

**SWEET-TALK**

THE MARK CONSISTS OF STANDARD CHARACTERS WITHOUT CLAIM TO ANY PARTICULAR FONT, STYLE, SIZE, OR COLOR.

FOR WINE; WINES (U.S. CLS. 47 AND 49).  
CHERYL CLAYTON, EXAMINING ATTORNEY

**CLASS 33—(Continued).**

SN 85-210,311. PURPLE WINE PRODUCTION COMPANY, GRATON, CA. FILED 1-4-2011.

**Dark Hundred**

THE MARK CONSISTS OF STANDARD CHARACTERS WITHOUT CLAIM TO ANY PARTICULAR FONT, STYLE, SIZE, OR COLOR.

FOR WINE; WINES (U.S. CLS. 47 AND 49).  
CHERYL CLAYTON, EXAMINING ATTORNEY

SN 85-210,321. PURPLE WINE PRODUCTION COMPANY, GRATON, CA. FILED 1-4-2011.

**Red Lie**

THE MARK CONSISTS OF STANDARD CHARACTERS WITHOUT CLAIM TO ANY PARTICULAR FONT, STYLE, SIZE, OR COLOR.

FOR WINE; WINES (U.S. CLS. 47 AND 49).  
CHERYL CLAYTON, EXAMINING ATTORNEY

SN 85-210,324. PURPLE WINE PRODUCTION COMPANY, GRATON, CA. FILED 1-4-2011.

**Reverse**

THE MARK CONSISTS OF STANDARD CHARACTERS WITHOUT CLAIM TO ANY PARTICULAR FONT, STYLE, SIZE, OR COLOR.

FOR WINE; WINES (U.S. CLS. 47 AND 49).  
CHERYL CLAYTON, EXAMINING ATTORNEY

SN 85-210,334. PURPLE WINE PRODUCTION COMPANY, GRATON, CA. FILED 1-4-2011.

**Brainstorm**

THE MARK CONSISTS OF STANDARD CHARACTERS WITHOUT CLAIM TO ANY PARTICULAR FONT, STYLE, SIZE, OR COLOR.

FOR WINE; WINES (U.S. CLS. 47 AND 49).  
CHERYL CLAYTON, EXAMINING ATTORNEY

**CLASS 33—(Continued).**

SN 85-210,341. PURPLE WINE PRODUCTION COMPANY, GRATON, CA. FILED 1-4-2011.

## Bar Napkin

THE MARK CONSISTS OF STANDARD CHARACTERS WITHOUT CLAIM TO ANY PARTICULAR FONT, STYLE, SIZE, OR COLOR.

FOR WINE; WINES (U.S. CLS. 47 AND 49).  
CHERYL CLAYTON, EXAMINING ATTORNEY

SN 85-216,647. 750 ML, LLC, MILFORD, DE. FILED 1-13-2011.

## BETSY'S

THE MARK CONSISTS OF STANDARD CHARACTERS WITHOUT CLAIM TO ANY PARTICULAR FONT, STYLE, SIZE, OR COLOR.

FOR ALCOHOLIC BEVERAGES EXCEPT BEERS (U.S. CLS. 47 AND 49).  
PAUL MORENO, EXAMINING ATTORNEY

SN 85-220,093. E. & J. GALLO WINERY, MODESTO, CA. FILED 1-18-2011.

## SPICELING

THE MARK CONSISTS OF STANDARD CHARACTERS WITHOUT CLAIM TO ANY PARTICULAR FONT, STYLE, SIZE, OR COLOR.

FOR WINES (U.S. CLS. 47 AND 49).  
TARA PATE, EXAMINING ATTORNEY

SN 85-220,107. E. & J. GALLO WINERY, MODESTO, CA. FILED 1-18-2011.

## PERKLING

THE MARK CONSISTS OF STANDARD CHARACTERS WITHOUT CLAIM TO ANY PARTICULAR FONT, STYLE, SIZE, OR COLOR.

FOR WINES (U.S. CLS. 47 AND 49).  
TARA PATE, EXAMINING ATTORNEY

**CLASS 33—(Continued).**

SN 85-220,774. SAZERAC COMPANY INC., NEW ORLEANS, LA. FILED 1-19-2011.



THE MARK CONSISTS OF A PICTURE OF A FIRE-BREATHING DRAGON OVER THE WORDS "UNLEASH THE DRAGON".

FOR WHISKEY-BASED LIQUEURS (U.S. CLS. 47 AND 49).  
KIM SAITO, EXAMINING ATTORNEY

SN 85-221,767. BARONESS SMALL ESTATES, INC., DENVER, CO. FILED 1-20-2011.

## BIRDS OF PREY

THE MARK CONSISTS OF STANDARD CHARACTERS WITHOUT CLAIM TO ANY PARTICULAR FONT, STYLE, SIZE, OR COLOR.

FOR WINE (U.S. CLS. 47 AND 49).  
FIRST USE 12-8-2010; IN COMMERCE 12-8-2010.  
PAUL MORENO, EXAMINING ATTORNEY

**CLASS 34—SMOKERS' ARTICLES**

SN 85-033,633. LOMBARD III, LOUIS, MARINA DEL REY, CA. FILED 5-8-2010.



NO CLAIM IS MADE TO THE EXCLUSIVE RIGHT TO USE "PIPE", APART FROM THE MARK AS SHOWN.

THE COLOR(S) BLACK, RED IS/ARE CLAIMED AS A FEATURE OF THE MARK.

THE MARK CONSISTS OF THE TERMS "EZ PIPE" WITH THE LETTER "Z" APPEARING IN RED AND THE LETTERS "E" AND "PIPE" APPEARING IN BLACK.

FOR SMOKING PIPES; TOBACCO PIPES (U.S. CLS. 2, 8, 9 AND 17).

FIRST USE 11-19-2009; IN COMMERCE 4-20-2010.  
ASMAT KHAN, EXAMINING ATTORNEY

**CLASS 34—(Continued).**

SN 85-069,869. GREGORY S. J. GILLET, HIGUEY, LA ALTAGRACIA, DOMINICAN REP, FILED 6-23-2010.

# DON LUCAS

THE MARK CONSISTS OF STANDARD CHARACTERS WITHOUT CLAIM TO ANY PARTICULAR FONT, STYLE, SIZE, OR COLOR.

THE NAME(S), PORTRAIT(S), AND/OR SIGNATURE(S) SHOWN IN THE MARK DOES NOT IDENTIFY A PARTICULAR LIVING INDIVIDUAL.

FOR CIGAR AND CIGARETTE BOXES; CIGAR CASES; CIGAR CUTTERS; CIGAR HOLDERS; CIGAR LIGHTERS; CIGARS; TOBACCO, CIGARS AND CIGARETTES (U.S. CLS. 2, 8, 9 AND 17).

AISHA CLARKE, EXAMINING ATTORNEY

SN 85-071,047. GLASS CHALICE, LLC, BERKELEY, CA. FILED 6-24-2010.



THE MARK CONSISTS OF ILLUSTRATION OF A LION'S HEAD WEARING A CROWN.

FOR SMOKERS' ARTICLES, NAMELY, CIGAR STORAGE TUBES, NON-METALLIC ASHTRAYS, TOBACCO PIPE BOWL STIRRING RODS, GLASS STIRRING RODS FOR TOBACCO PIPES, HOOKAHS, PIPE TOBACCO, ROLLING TOBACCO, LIGHTERS FOR SMOKERS, MATCHES, CIGARETTE ROLLING PAPERS, GLASS STORAGE CONTAINERS FOR TOBACCO PRODUCTS, GLASS STOPPERS FOR TOBACCO PIPES, GLASS PLUGS FOR TOBACCO PIPES, GLASS PIPES AND WATER PIPES (U.S. CLS. 2, 8, 9 AND 17).

FIRST USE 6-1-2010; IN COMMERCE 6-1-2010.

GINA HAYES, EXAMINING ATTORNEY

**CLASS 34—(Continued).**

SN 85-071,051. GLASS CHALICE, LLC, BERKELEY, CA. FILED 6-24-2010.

# MIGHTY CHALICE

THE MARK CONSISTS OF STANDARD CHARACTERS WITHOUT CLAIM TO ANY PARTICULAR FONT, STYLE, SIZE, OR COLOR.

FOR SMOKERS' ARTICLES, NAMELY, CIGAR STORAGE TUBES, NON-METALLIC ASHTRAYS, TOBACCO PIPE BOWL STIRRING RODS, GLASS STIRRING RODS FOR TOBACCO PIPES, HOOKAHS, PIPE TOBACCO, ROLLING TOBACCO, LIGHTERS FOR SMOKERS, MATCHES, CIGARETTE ROLLING PAPERS, GLASS STORAGE CONTAINERS FOR TOBACCO PRODUCTS, GLASS STOPPERS FOR TOBACCO PIPES, GLASS PLUGS FOR TOBACCO PIPES, GLASS PIPES AND WATER PIPES (U.S. CLS. 2, 8, 9 AND 17).

FIRST USE 6-1-2010; IN COMMERCE 6-1-2010.

GINA HAYES, EXAMINING ATTORNEY

SN 85-107,803. SORSA HOLDINGS INC, BROOKLYN, NY. FILED 8-15-2010.

# country clove

THE MARK CONSISTS OF STANDARD CHARACTERS WITHOUT CLAIM TO ANY PARTICULAR FONT, STYLE, SIZE, OR COLOR.

NO CLAIM IS MADE TO THE EXCLUSIVE RIGHT TO USE "CLOVE", APART FROM THE MARK AS SHOWN.

FOR ELECTRONIC CIGARETTES, ELECTRONIC CIGARETTES' PARTS COMPONENTS AND ACCESSORIES, NAMELY, CARTRIDGES, CARTOMISERS, REFILLS AND ATOMISERS, WHICH ARE INTERNAL AND STRUCTURAL PARTS (U.S. CLS. 2, 8, 9 AND 17).

FIRST USE 7-20-2010; IN COMMERCE 7-20-2010.

MORGAN WYNNE, EXAMINING ATTORNEY

SN 85-129,903. BBK TOBACCO AND FOODS, L.L.P., PHOENIX, AZ. FILED 9-15-2010.

# UNGUMMED CLUB SANS GOMMÉ

THE MARK CONSISTS OF STANDARD CHARACTERS WITHOUT CLAIM TO ANY PARTICULAR FONT, STYLE, SIZE, OR COLOR.

NO CLAIM IS MADE TO THE EXCLUSIVE RIGHT TO USE "UNGUMMED" AND "SANS GOMMÉ", APART FROM THE MARK AS SHOWN.

THE ENGLISH TRANSLATION OF "SANS GOMMÉ" IN THE MARK IS "WITHOUT GUM".

FOR CIGARETTE FILTERS; CIGARETTE ROLLING PAPERS; CIGARETTE TUBES; CIGARETTE-ROLLING MACHINES (U.S. CLS. 2, 8, 9 AND 17).

RENEE MCCRAY, EXAMINING ATTORNEY

**CLASS 34—(Continued).**

SN 85-140,804. BBK TOBACCO & FOODS, LLP, PHOENIX, AZ. FILED 9-29-2010.



OWNER OF U.S. REG. NO. 3,233,110.  
NO CLAIM IS MADE TO THE EXCLUSIVE RIGHT TO USE "PRE ROLLED PERFECT CONE", APART FROM THE MARK AS SHOWN.

THE MARK CONSISTS OF THE STYLIZED WORD "CYCLONES" WITH A CYCLONE DESIGN ELEMENT REPRESENTING THE LETTER "O". BENEATH THE WORD "CYCLONES" APPEARS THE WORDING "PRE ROLLED PERFECT CONE". THE CYCLONE DESIGN ELEMENT EXTENDS BETWEEN THE TERMS "PRE ROLLED" AND "PERFECT CONE".

FOR CIGARETTE ROLLING PAPERS; CIGARETTES; CIGARS; TOBACCO (U.S. CLS. 2, 8, 9 AND 17).

FIRST USE 3-15-2009; IN COMMERCE 3-15-2009.  
GEOFFREY FOSDICK, EXAMINING ATTORNEY

**CLASS 34—(Continued).**

SHAPED DIAGONAL BAND. THERE ARE IRREGULAR SHAPED WINDOWS, OUTLINED IN GRADATED GOLD, LOCATED IN THE CENTER ABOVE AND BELOW THE DARK BROWN IRREGULAR SHAPED DIAGONAL BAND. THE WORD "CLASSIC", IN DARK BROWN, IS LOCATED WITHIN THE GRADATED GOLD OUTLINE OF THE LOWER IRREGULAR SHAPED WINDOW. THE WORD "CIGARILLOS", IN WHITE, IS LOCATED IN THE CENTER BELOW THE WORD "CLASSIC". THERE ARE GRADATED GOLD LINES ABOVE AND BELOW THE WORD "CIGARILLOS".

SEC. 2(F) AS TO "BLACK & MILD".  
FOR TOBACCO PRODUCTS, NAMELY, CIGARS (U.S. CLS. 2, 8, 9 AND 17).  
TARAH HARDY, EXAMINING ATTORNEY

SN 85-150,607. JOHN MIDDLETON CO., KING OF PRUSSIA, PA. FILED 10-12-2010.



OWNER OF U.S. REG. NOS. 1,103,566, 2,712,704 AND OTHERS.

NO CLAIM IS MADE TO THE EXCLUSIVE RIGHT TO USE "SINCE 1856" "CLASSIC" AND "CIGARILLOS", APART FROM THE MARK AS SHOWN.

THE COLOR(S) BROWN, DARK BROWN, BLACK, GOLD, AND WHITE IS/ARE CLAIMED AS A FEATURE OF THE MARK.

THE MARK CONSISTS OF A GRADATED BROWN RECTANGULAR DESIGN. THERE IS A DARK BROWN IRREGULAR SHAPED DIAGONAL BAND, OUTLINED IN GRADATED GOLD, WITH GRADATED BROWN IN THE CENTER, LOCATED IN THE GRADATED BROWN RECTANGULAR DESIGN. THERE ARE THIN GRADATED GOLD LINES ALONG THE TOP AND BOTTOM EDGE OF THE DARK BROWN IRREGULAR SHAPED DIAGONAL BAND. THE WORDS "MIDDLETON'S", IN WHITE, "BLACK", IN WHITE WITH A BLACK OUTLINE, & "MILD", IN WHITE WITH A BLACK OUTLINE, AND "SINCE 1856", IN WHITE, ARE LOCATED WITHIN THE GRADATED BROWN CENTER OF THE DARK BROWN IRREGULAR

SN 85-150,615. JOHN MIDDLETON CO., KING OF PRUSSIA, PA. FILED 10-12-2010.



OWNER OF U.S. REG. NOS. 1,103,566, 2,712,704 AND OTHERS.

NO CLAIM IS MADE TO THE EXCLUSIVE RIGHT TO USE "SINCE 1856" "CLASSIC" AND "CIGARILLOS", APART FROM THE MARK AS SHOWN.

THE MARK CONSISTS OF A GRADATED RECTANGULAR DESIGN. THERE IS AN IRREGULAR SHAPED DIAGONAL BAND, WITH A GRADATED OUTLINE AND A GRADATED CENTER, LOCATED IN THE GRADATED RECTANGULAR DESIGN. THERE ARE THIN GRADATED LINES ALONG THE TOP AND BOTTOM EDGE OF THE IRREGULAR SHAPED DIAGONAL BAND. THE WORDS "MIDDLETON'S", "BLACK & MILD", AND "SINCE 1856" ARE LOCATED WITHIN THE GRADATED CENTER OF THE IRREGULAR SHAPED DIAGONAL BAND. THERE ARE IRREGULAR SHAPED WINDOWS WITH GRADATED OUTLINES LOCATED IN THE CENTER ABOVE AND BELOW THE IRREGULAR SHAPED DIAGONAL BAND. THE WORD "CLASSIC" IS LOCATED WITHIN THE GRADATED OUTLINE OF THE LOWER IRREGULAR SHAPED WINDOW. THE WORD "CIGARILLOS" IS LOCATED IN THE CENTER BELOW THE WORD "CLASSIC". THERE ARE GRADATED LINES ABOVE AND BELOW THE WORD "CLASSIC".

SEC. 2(F) AS TO "BLACK & MILD".  
FOR TOBACCO PRODUCTS, NAMELY, CIGARS (U.S. CLS. 2, 8, 9 AND 17).

TARAH HARDY, EXAMINING ATTORNEY

**CLASS 34—(Continued).**

SN 85-150,628. JOHN MIDDLETON CO., KING OF PRUSSIA, PA. FILED 10-12-2010.



OWNER OF U.S. REG. NOS. 1,103,566, 2,712,704 AND OTHERS.

NO CLAIM IS MADE TO THE EXCLUSIVE RIGHT TO USE "SINCE 1856" "SWEETS" AND "CIGARILLOS", APART FROM THE MARK AS SHOWN.

THE COLOR(S) RED, BLACK, GOLD, AND WHITE IS/ ARE CLAIMED AS A FEATURE OF THE MARK.

THE MARK CONSISTS OF A RED RECTANGULAR DESIGN. THERE IS A RED IRREGULAR SHAPED DIAGONAL BAND, OUTLINED IN WHITE, WITH GRADATION IN THE CENTER, LOCATED IN THE RED RECTANGULAR DESIGN. THERE ARE THIN GRADATED GOLD LINES ALONG THE TOP AND BOTTOM EDGE OF THE RED IRREGULAR SHAPED DIAGONAL BAND. THE WORDS "MIDDLETON'S", IN WHITE, "BLACK", IN WHITE WITH A BLACK OUTLINE, &, IN GRADATED GOLD WITH A BLACK OUTLINE, "MILD", IN WHITE WITH A BLACK OUTLINE, AND "SINCE 1856", IN WHITE, ARE LOCATED WITHIN THE GRADATED CENTER OF THE RED IRREGULAR SHAPED DIAGONAL BAND. THERE ARE IRREGULAR SHAPED WINDOWS, OUTLINED IN WHITE, LOCATED IN THE CENTER ABOVE AND BELOW THE RED IRREGULAR SHAPED DIAGONAL BAND. THE WORD "SWEETS", IN RED, IS LOCATED WITHIN THE WHITE OUTLINE OF THE LOWER IRREGULAR SHAPED WINDOW. THERE ARE DASHES, IN GOLD, LOCATED TO THE LEFT AND RIGHT OF THE WORD "SWEETS". THE WORD "CIGARILLOS", IN WHITE, IS LOCATED IN THE CENTER BELOW THE WORD "SWEETS". THERE ARE GRADATED GOLD LINES ABOVE AND BELOW THE WORD "CIGARILLOS".

SEC. 2(F) AS TO "BLACK & MILD".  
FOR TOBACCO PRODUCTS, NAMELY, CIGARS (U.S. CLS. 2, 8, 9 AND 17).

TARAH HARDY, EXAMINING ATTORNEY

**CLASS 34—(Continued).**

SN 85-150,636. JOHN MIDDLETON CO., KING OF PRUSSIA, PA. FILED 10-12-2010.



OWNER OF U.S. REG. NOS. 1,103,566, 2,712,704 AND OTHERS.

NO CLAIM IS MADE TO THE EXCLUSIVE RIGHT TO USE "SINCE 1856" "SWEETS" AND "CIGARILLOS", APART FROM THE MARK AS SHOWN.

THE MARK CONSISTS OF A RECTANGULAR DESIGN. THERE IS AN IRREGULAR SHAPED DIAGONAL BAND, WITH AN OUTLINE AND A GRADATED CENTER, LOCATED IN THE RECTANGULAR DESIGN. THERE ARE THIN GRADATED LINES ALONG THE TOP AND BOTTOM EDGE OF THE IRREGULAR SHAPED DIAGONAL BAND. THE WORDS "MIDDLETON'S, BLACK & MILD", AND "SINCE 1856" ARE LOCATED WITHIN THE GRADATED CENTER OF THE IRREGULAR SHAPED DIAGONAL BAND. THERE ARE IRREGULAR SHAPED WINDOWS WITH OUTLINES LOCATED IN THE CENTER ABOVE AND BELOW THE IRREGULAR SHAPED DIAGONAL BAND. THE WORD "SWEETS" IS LOCATED WITHIN THE OUTLINE OF THE LOWER IRREGULAR SHAPED WINDOW. THE WORD "CIGARILLOS" IS LOCATED IN THE CENTER BELOW THE WORD "SWEETS". THERE ARE GRADATED LINES ABOVE AND BELOW THE WORD "SWEETS".

SEC. 2(F) AS TO "BLACK & MILD".  
FOR TOBACCO PRODUCTS, NAMELY, CIGARS (U.S. CLS. 2, 8, 9 AND 17).

TARAH HARDY, EXAMINING ATTORNEY

SN 85-176,332. GAJANI, SAMIR F, CARROLLTON, TX. FILED 11-14-2010.

**WANTED**

THE MARK CONSISTS OF STANDARD CHARACTERS WITHOUT CLAIM TO ANY PARTICULAR FONT, STYLE, SIZE, OR COLOR.

FOR CIGARETTE PAPER; CIGARETTE PAPERS; CIGARETTE ROLLING MACHINES; CIGARETTE ROLLING PAPERS; CIGARETTE TUBES; CIGARETTE ROLLING MACHINES; HAND-HELD MACHINES FOR INJECTING TOBACCO INTO CIGARETTE TUBES; POCKET MACHINES FOR ROLLING CIGARETTES; POCKET-SIZE CIGARETTE ROLLING MACHINES (U.S. CLS. 2, 8, 9 AND 17).

FIRST USE 11-12-2010; IN COMMERCE 11-12-2010.

MORGAN WYNNE, EXAMINING ATTORNEY



**CLASS 34—(Continued).**

SN 85-176,498. OUTLAW CIGAR LLC, OVERLAND PARK, KS. FILED 11-15-2010.

# GUNSLINGER

THE MARK CONSISTS OF STANDARD CHARACTERS WITHOUT CLAIM TO ANY PARTICULAR FONT, STYLE, SIZE, OR COLOR.

FOR CIGARS (U.S. CLS. 2, 8, 9 AND 17).  
FIRST USE 11-9-2010; IN COMMERCE 11-9-2010.  
ANDREW RHIM, EXAMINING ATTORNEY

**CLASS 34—(Continued).**

SN 85-178,874. ELEMENTAL TECHNOLOGIES, LLC, SEATTLE, WA. FILED 11-17-2010.



THE MARK CONSISTS OF A FIREBALL LOGO WITH THE LETTERS 'VS' ENCLOSED WITHIN THE CIRCLE. FOR SMOKING PIPES (U.S. CLS. 2, 8, 9 AND 17). FIRST USE 8-8-2010; IN COMMERCE 9-22-2010. DARRYL SPRUILL, EXAMINING ATTORNEY

SN 85-178,593. ELEMENTAL TECHNOLOGIES, LLC, SEATTLE, WA. FILED 11-17-2010.

# VAPE-OR-SMOKE

THE MARK CONSISTS OF STANDARD CHARACTERS WITHOUT CLAIM TO ANY PARTICULAR FONT, STYLE, SIZE, OR COLOR.

FOR SMOKING PIPES (U.S. CLS. 2, 8, 9 AND 17).  
FIRST USE 4-20-2010; IN COMMERCE 8-8-2010.  
DARRYL SPRUILL, EXAMINING ATTORNEY

SN 85-179,522. DISCOUNT TOBACCO PRODUCTS, INC., FARMINGTON HILLS, MI. FILED 11-17-2010.

# BEAMER

THE MARK CONSISTS OF STANDARD CHARACTERS WITHOUT CLAIM TO ANY PARTICULAR FONT, STYLE, SIZE, OR COLOR.

FOR TOBACCO SUBSTITUTES, NAMELY, HERBAL MOLASSES (U.S. CLS. 2, 8, 9 AND 17).  
JOHN WILKE, EXAMINING ATTORNEY

SN 85-178,598. ELEMENTAL TECHNOLOGIES, LLC, SEATTLE, WA. FILED 11-17-2010.

# The Ultimate Tool

THE MARK CONSISTS OF STANDARD CHARACTERS WITHOUT CLAIM TO ANY PARTICULAR FONT, STYLE, SIZE, OR COLOR.

FOR SMOKING PIPES (U.S. CLS. 2, 8, 9 AND 17).  
FIRST USE 4-20-2010; IN COMMERCE 8-8-2010.  
DARRYL SPRUILL, EXAMINING ATTORNEY

SN 85-181,042. RENEGADE TOBACCO COMPANY, MOCKSVILLE, NC. FILED 11-19-2010.

# Rampage

THE MARK CONSISTS OF STANDARD CHARACTERS WITHOUT CLAIM TO ANY PARTICULAR FONT, STYLE, SIZE, OR COLOR.

FOR TOBACCO, CIGARS AND CIGARETTES (U.S. CLS. 2, 8, 9 AND 17).  
CHRISTINA SOBRAL, EXAMINING ATTORNEY

**CLASS 34—(Continued).**

SN 85-191,738. 510 OAKSTERDAM HYDROPONICS, LLC, OAKLAND, CA. FILED 12-6-2010.

# OHganics

THE MARK CONSISTS OF STANDARD CHARACTERS WITHOUT CLAIM TO ANY PARTICULAR FONT, STYLE, SIZE, OR COLOR.

FOR CIGAR WRAPS; CIGARETTE PAPERS; CIGARETTE ROLLING PAPERS (U.S. CLS. 2, 8, 9 AND 17).  
ROBERT STRUCK, EXAMINING ATTORNEY

---

SN 85-198,325. DISCOUNT TOBACCO PRODUCTS, INC., FARMINGTON HILLS, MI. FILED 12-15-2010.

## Huge Clouds, Amazing Taste!

THE MARK CONSISTS OF STANDARD CHARACTERS WITHOUT CLAIM TO ANY PARTICULAR FONT, STYLE, SIZE, OR COLOR.

FOR TOBACCO SUBSTITUTES, NAMELY, HERBAL MOLASSES (U.S. CLS. 2, 8, 9 AND 17).  
JOHN WILKE, EXAMINING ATTORNEY

---

**SERVICE MARKS**

**CLASS 35—ADVERTISING AND BUSINESS**

SN 76-702,767. TWIN TOWERS TRADING CORPORATION, MANALAPAN, NJ. FILED 5-3-2010.

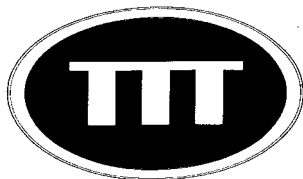

THE MARK CONSISTS OF THE STYLIZED LETTERS "TTT" INSIDE AN OVAL.

FOR PROMOTION AND DEMONSTRATION SERVICES OF CONSUMER PRODUCTS OF OTHERS BEFORE LIVE AUDIENCES ON TELEVISION AND AT RETAIL ENVIRONMENTS (U.S. CLS. 100, 101 AND 102).  
FIRST USE 9-12-2001; IN COMMERCE 9-12-2001.  
LANA PHAM, EXAMINING ATTORNEY

**CLASS 35—(Continued).**

SN 76-702,768. TWIN TOWERS TRADING CORPORATION, MANALAPAN, NJ. FILED 5-3-2010.

# TWIN TOWERS TRADING

THE MARK CONSISTS OF STANDARD CHARACTERS WITHOUT CLAIM TO ANY PARTICULAR FONT, STYLE, SIZE, OR COLOR.

NO CLAIM IS MADE TO THE EXCLUSIVE RIGHT TO USE "TRADING", APART FROM THE MARK AS SHOWN.  
FOR PROMOTION AND DEMONSTRATION SERVICES OF CONSUMER PRODUCTS OF OTHERS BEFORE LIVE AUDIENCES ON TELEVISION AND AT RETAIL ENVIRONMENTS (U.S. CLS. 100, 101 AND 102).  
FIRST USE 6-1-1994; IN COMMERCE 6-1-1994.  
LANA PHAM, EXAMINING ATTORNEY

---

SN 76-704,926. ANYTHING GOES, INC., ALLENHURST, NJ. FILED 10-18-2010.

# ANYTHING GOES

THE MARK CONSISTS OF STANDARD CHARACTERS WITHOUT CLAIM TO ANY PARTICULAR FONT, STYLE, SIZE, OR COLOR.

FOR ONLINE RETAIL STORE SERVICES AND MAIL ORDER CATALOG SERVICES FEATURING JEWELRY (U.S. CLS. 100, 101 AND 102).  
FIRST USE 6-0-1994; IN COMMERCE 6-0-1994.  
KELLY TRUSILO, EXAMINING ATTORNEY

---

SN 76-705,372. INKHOUSE, LLC, WALTHAM, MA. FILED 11-17-2010.

# INKHOUSE

THE MARK CONSISTS OF STANDARD CHARACTERS WITHOUT CLAIM TO ANY PARTICULAR FONT, STYLE, SIZE, OR COLOR.

FOR PUBLIC RELATIONS SERVICES (U.S. CLS. 100, 101 AND 102).  
FIRST USE 2-1-2007; IN COMMERCE 2-1-2007.  
GINA HAYES, EXAMINING ATTORNEY

**CLASS 35—(Continued).**

SN 77-039,144. WORKFORCE INSIGHT, LITTLETON, CO. FILED 11-7-2006.

**WORKFORCE INSIGHT**

THE MARK CONSISTS OF STANDARD CHARACTERS WITHOUT CLAIM TO ANY PARTICULAR FONT, STYLE, SIZE, OR COLOR.

NO CLAIM IS MADE TO THE EXCLUSIVE RIGHT TO USE "WORKFORCE", APART FROM THE MARK AS SHOWN.

FOR ADVICE RELATING TO THE ORGANISATION AND MANAGEMENT OF BUSINESS; ASSISTANCE IN MANAGEMENT OF BUSINESS ACTIVITIES; ASSISTANCE WITH BUSINESS MANAGEMENT AND PLANNING; BUSINESS ADMINISTRATION AND MANAGEMENT; BUSINESS ADMINISTRATION CONSULTANCY; BUSINESS ADVISORY SERVICES, CONSULTANCY AND INFORMATION; BUSINESS CONSULTATION; BUSINESS CONSULTATION SERVICES; BUSINESS CONSULTING AND BUSINESS INFORMATION FOR ENTERPRISES; BUSINESS CONSULTING AND INFORMATION SERVICES; BUSINESS CONSULTING, INQUIRIES OR INFORMATION; BUSINESS CONSULTING, MANAGEMENT, PLANNING AND SUPERVISION; BUSINESS MANAGEMENT; BUSINESS MANAGEMENT AND ADVICE; BUSINESS MANAGEMENT AND CONSULTATION; BUSINESS MANAGEMENT CONSULTANCY AND ADVISORY SERVICES; BUSINESS MANAGEMENT CONSULTANCY AS WELL AS DEVELOPMENT OF PROCESSES FOR THE ANALYSIS AND THE IMPLEMENTATION OF STRATEGY PLANS AND MANAGEMENT PROJECTS; BUSINESS MANAGEMENT CONSULTANCY SERVICES; BUSINESS MANAGEMENT CONSULTATION; BUSINESS MANAGEMENT CONSULTING AND ADVISORY SERVICES; BUSINESS ORGANISATION AND MANAGEMENT CONSULTING SERVICES; BUSINESS ORGANIZATION AND OPERATION CONSULTANCY; BUSINESS ORGANIZATIONAL CONSULTATION; CONSULTANCY OF PERSONNEL RECRUITMENT; CONSULTANCY SERVICES REGARDING BUSINESS STRATEGIES; CONSULTING SERVICES IN BUSINESS ORGANIZATION AND MANAGEMENT; HUMAN RESOURCES CONSULTATION; HUMAN RESOURCES MANAGEMENT; PERSONNEL CONSULTANCY; PERSONNEL MANAGEMENT; PERSONNEL MANAGEMENT CONSULTATION; PROFESSIONAL BUSINESS CONSULTATION (U.S. CLS. 100, 101 AND 102).

FIRST USE 3-13-2006; IN COMMERCE 5-8-2006.  
DAWN HAN, EXAMINING ATTORNEY

**CLASS 35—(Continued).**

SN 77-293,331. KOH, HYUN-LIM, SEOUL, REPUBLIC OF KOREA, FILED 10-1-2007.

**samplelab**

THE MARK CONSISTS OF STANDARD CHARACTERS WITHOUT CLAIM TO ANY PARTICULAR FONT, STYLE, SIZE, OR COLOR.

OWNER OF REPUBLIC OF KOREA REG. NO. 41-0183726, DATED 4-10-2009, EXPIRES 4-10-2019.

FOR DISTRIBUTION OF PROSPECTUSES AND SAMPLES; ORGANIZATION AND HOLDING OF FAIRS FOR COMMERCIAL OR ADVERTISING PURPOSES; ADVERTISING VIA ELECTRONIC MEDIA AND SPECIFICALLY THE INTERNET; PROVIDING AND RENTAL OF ADVERTISING SPACE ON THE INTERNET; RENTAL OF ADVERTISING SPACE ON WEB SITES; DISSEMINATION OF ADVERTISING FOR OTHERS VIA AN ONLINE COMMUNICATIONS NETWORK ON THE INTERNET; DISTRIBUTORSHIP SERVICES FEATURING CONSUMER ELECTRONICS, NAMELY, COMPUTERS; DISTRIBUTORSHIP SERVICES IN THE FIELD OF HOUSEHOLD APPLIANCES; RETAIL STORE SERVICES FEATURING TELECOMMUNICATIONS, ELECTRIC AND UTILITY SERVICES OF OTHERS; DISTRIBUTORSHIP SERVICES FEATURING COMMUNICATION DEVICES, NAMELY, CELLULAR PHONES; DISTRIBUTORSHIP SERVICES FEATURING COMMUNICATION DEVICES, NAMELY, CELLULAR PHONES; DISTRIBUTION AND DISSEMINATION OF ADVERTISING MATERIALS, NAMELY, SAMPLES; DISTRIBUTORSHIP SERVICES IN THE FIELD OF SPORTING GOODS; DISTRIBUTORSHIP SERVICES IN THE FIELD OF CLOTHING; DISTRIBUTORSHIP SERVICES IN THE FIELD OF COSMETICS; RETAIL COSMETIC STORES (U.S. CLS. 100, 101 AND 102).

JILL C. ALT, EXAMINING ATTORNEY

SN 77-428,321. BABY FANS, INC., SANTA BARBARA, CA. FILED 3-21-2008.



NO CLAIM IS MADE TO THE EXCLUSIVE RIGHT TO USE "BABY", APART FROM THE MARK AS SHOWN.

THE MARK CONSISTS OF THE COLOR BLUE APPEARING IN THE WORDING "BABY FANS" AND THE BABY DESIGN; THE COLOR WHITE APPEARS IN THE DIAPER ON THE BABY DESIGN AND THE FOOTBALL; THE COLOR BROWN APPEARS IN THE FOOTBALL AND THE WORDING "ONCE A FAN, ALWAYS A FAN".

FOR ONLINE RETAIL STORE SERVICES FEATURING PROFESSIONAL AND COLLEGE SPORTS LEAGUE AND TEAM APPAREL AND ACCESSORIES, NAMELY, PACIFIERS, SIPPY CUPS, BOTTLES AND MOBILES FOR CRIBS, SUNSHADES FOR BABIES AND INFANTS (U.S. CLS. 100, 101 AND 102).

FIRST USE 3-1-2005; IN COMMERCE 3-1-2005.  
CHRISTOPHER BUONGIORNO, EXAMINING ATTORNEY

**CLASS 35—(Continued).**

SN 77-531,023. TYCO HEALTHCARE GROUP, LP, MANSFIELD, MA. FILED 7-24-2008.

ADMD

THE MARK CONSISTS OF STANDARD CHARACTERS WITHOUT CLAIM TO ANY PARTICULAR FONT, STYLE, SIZE, OR COLOR.

FOR ADVERTISING AND MARKETING SERVICES IN THE FIELD OF MEDICAL PRACTICES (U.S. CLS. 100, 101 AND 102).

ALICE BENMAMAN, EXAMINING ATTORNEY

SN 77-573,700. LEEKE, KATHRYN, SAN DIEGO, CA. FILED 9-18-2008.



NO CLAIM IS MADE TO THE EXCLUSIVE RIGHT TO USE "KIDZ", APART FROM THE MARK AS SHOWN.

THE COLOR(S) YELLOW, ORANGE AND WHITE IS/ARE CLAIMED AS A FEATURE OF THE MARK.

THE MARK CONSISTS OF THE WORDS "NATURALKIDZ" DEPICTED BENEATH A DESIGN COMPRISED OF YELLOW AND ORANGE LEAVES ON A STYLIZED WHITE TREE WITHIN AN ORANGE CIRCLE.

FOR ONLINE WHOLESALE AND RETAIL STORE SERVICES FEATURING ORGANIC AND SUSTAINABLE MATERIALS, NAMELY, CLOTHING, JEWELRY, BOTTLES, COSMETICS, TOYS, BAGS, BEDDING, LINENS, FURNITURE, BOOKS, AND WHOLESALE AND RETAIL STORE SERVICES FEATURING ORGANIC AND SUSTAINABLE MATERIALS, NAMELY, CLOTHING, JEWELRY, BOTTLES, COSMETICS, TOYS, BAGS, BEDDING, LINENS, FURNITURE (U.S. CLS. 100, 101 AND 102).

FIRST USE 8-15-2008; IN COMMERCE 8-15-2008.

KATHERINE STOIDES, EXAMINING ATTORNEY

**CLASS 35—(Continued).**

SN 77-626,118. WEST COAST DEALS, INC., HUNTINGTON BEACH, CA. FILED 12-4-2008.



NO CLAIM IS MADE TO THE EXCLUSIVE RIGHT TO USE "SUNGLASS COMPANY", APART FROM THE MARK AS SHOWN.

THE COLOR(S) BLACK, RED, GREY, AND YELLOW IS/ARE CLAIMED AS A FEATURE OF THE MARK.

THE MARK CONSISTS OF THE LETTERS "HB" IN BLACK WITH GREY OUTLINE OVER A HORIZONTAL SURFBOARD IN RED WITH GREY OUTLINE HAVING TWO YELLOW HORIZONTAL STRIPES; ALL ABOVE THE BLACK WORDS "SUNGLASS COMPANY".

FOR WHOLESALE STORES FEATURING EYEWEAR, SUNGLASSES, HAIR CLIPS, AND JEWELRY; ONLINE WHOLESALE STORE FEATURING EYEWEAR, SUNGLASSES, HAIR CLIPS, AND JEWELRY (U.S. CLS. 100, 101 AND 102).

FIRST USE 0-0-2003; IN COMMERCE 0-0-2003.

MAYUR VAGHANI, EXAMINING ATTORNEY

SN 77-760,509. LEVERAGED MEDIA, LLC, COLUMBIA, SC. FILED 6-16-2009.

LEVERAGED MEDIA

THE MARK CONSISTS OF STANDARD CHARACTERS WITHOUT CLAIM TO ANY PARTICULAR FONT, STYLE, SIZE, OR COLOR.

NO CLAIM IS MADE TO THE EXCLUSIVE RIGHT TO USE "MEDIA", APART FROM THE MARK AS SHOWN.

FOR ADVERTISING AND MARKETING SERVICES OTHER THAN IN-STORE MARKETING, NAMELY, PROMOTING THE GOODS AND SERVICES OF OTHERS BY OFFERING ADVERTISEMENT TEMPLATES, AND DISTRIBUTING E-MAILS AND DIRECT MAIL OF ADVERTISEMENTS FOR OTHERS (U.S. CLS. 100, 101 AND 102).

KEVIN CORWIN, EXAMINING ATTORNEY

**CLASS 35—(Continued).**

SN 77-760,522. LEVERAGED MEDIA, LLC, COLUMBIA, SC. FILED 6-16-2009.

**POTENTIAL PROMOTERS**

THE MARK CONSISTS OF STANDARD CHARACTERS WITHOUT CLAIM TO ANY PARTICULAR FONT, STYLE, SIZE, OR COLOR.

NO CLAIM IS MADE TO THE EXCLUSIVE RIGHT TO USE "PROMOTERS", APART FROM THE MARK AS SHOWN.

FOR ADVERTISING AND MARKETING SERVICES, NAMELY, PROMOTING THE GOODS AND SERVICES OF OTHERS BY OFFERING ADVERTISEMENT TEMPLATES, OTHER THAN CUSTOMIZED ADVERTISEMENTS, AND DISTRIBUTING E-MAILS AND DIRECT MAIL OF ADVERTISEMENTS FOR OTHERS (U.S. CLS. 100, 101 AND 102).

KEVIN CORWIN, EXAMINING ATTORNEY

---

SN 77-785,689. PERMIAN BASIN WOMEN'S RESOURCE CENTER, INC., DBA THE LIFE CENTER, MIDLAND, TX. FILED 7-21-2009.

**YWUDI**

THE MARK CONSISTS OF STANDARD CHARACTERS WITHOUT CLAIM TO ANY PARTICULAR FONT, STYLE, SIZE, OR COLOR.

FOR PROMOTING PUBLIC AWARENESS OF THE NEED FOR SEXUAL INTEGRITY (U.S. CLS. 100, 101 AND 102).

FIRST USE 3-1-2009; IN COMMERCE 3-1-2009. ANDREW LEASER, EXAMINING ATTORNEY

**CLASS 35—(Continued).**

SN 77-844,990. JEJU SPECIAL SELF-GOVERNING PROVINCE, JEJU-SI, REPUBLIC OF KOREA, FILED 10-9-2009.



PRIORITY CLAIMED UNDER SEC. 44(D) ON REPUBLIC OF KOREA APPLICATION NO. 2009-0017718, FILED 8-3-2009, REG. NO. 0203174, DATED 11-9-2010, EXPIRES 11-9-2020.

NO CLAIM IS MADE TO THE EXCLUSIVE RIGHT TO USE "JEJU OFFICIAL CERTIFICATION WATER" AND "JEJU WATER", APART FROM THE MARK AS SHOWN.

THE COLOR(S) BLUE, GRAY, GREEN AND LIGHT BLUE IS/ARE CLAIMED AS A FEATURE OF THE MARK.

THE MARK CONSISTS OF THE SEMI-CIRCULAR GRAY WORDING "JEJU OFFICIAL CERTIFICATION WATER" ON THE TOP HALF BETWEEN TWO BLUE CONCENTRIC CIRCLES AND THE BLUE WORDING "JEJU WATER" ON THE BOTTOM BETWEEN TWO BLUE CONCENTRIC CIRCLES. INSIDE THE BLUE CONCENTRIC CIRCLES IS A STYLIZED REPRESENTATION OF A FACE COMPRISED OF A GREEN AND GRAY HAT, BLUE EYES AND NOSE AND A LIGHT BLUE MOUTH.

FOR DISTRIBUTORSHIP SERVICES AND RETAIL AND WHOLESALE STORE SERVICES FOR DRINKING WATER AND MINERAL WATER; DISTRIBUTORSHIP SERVICES AND RETAIL AND WHOLESALE STORE SERVICES FOR JUICE AND NON-ALCOHOLIC BEVERAGES; DISTRIBUTORSHIP SERVICES AND RETAIL AND WHOLESALE STORE SERVICES FOR LIQUOR (U.S. CLS. 100, 101 AND 102).

ALLISON HOLTZ, EXAMINING ATTORNEY

---

SN 77-847,345. THERAPISTS ON DEMAND, INC., PHILADELPHIA, PA. FILED 10-13-2009.



NO CLAIM IS MADE TO THE EXCLUSIVE RIGHT TO USE "INC.", APART FROM THE MARK AS SHOWN.

THE COLOR(S) BLUE AND BLACK IS/ARE CLAIMED AS A FEATURE OF THE MARK.

THE MARK CONSISTS OF A BLUE HUMAN FIGURE RUNNING ABOVE THE BLACK WORDS "THERAPISTS ON DEMAND, INC." ABOVE THE BLACK WORDS "T.O.D. WORKING FOR YOU!"

SEC. 2(F) AS TO "THERAPISTS ON DEMAND". FOR EMPLOYMENT AGENCY SERVICES, NAMELY, FILLING THE TEMPORARY AND PERMANENT STAFFING NEEDS OF BUSINESSES (U.S. CLS. 100, 101 AND 102).

FIRST USE 10-1-2005; IN COMMERCE 10-1-2005. ANDREA K. NADELMAN, EXAMINING ATTORNEY

**CLASS 35—(Continued).**

SN 77-858,084. J&L MARKETING, INC., LOUISVILLE, KY.  
FILED 10-27-2009.

**BREFERRED**

THE MARK CONSISTS OF STANDARD CHARACTERS WITHOUT CLAIM TO ANY PARTICULAR FONT, STYLE, SIZE, OR COLOR.

FOR ARRANGING AND CONDUCTING INCENTIVE REWARD PROGRAMS THROUGH THE ISSUANCE OF CASH INCENTIVES OR CREDIT VOUCHERS USING DIRECT RESPONSE MARKETING (U.S. CLS. 100, 101 AND 102).

NAPOLEON SHARMA, EXAMINING ATTORNEY

---

SN 77-860,384. TRIMARCHE, GREGORY D., IRVINE, CA.  
FILED 10-29-2009.



NO CLAIM IS MADE TO THE EXCLUSIVE RIGHT TO USE "CLEANTECHOC", APART FROM THE MARK AS SHOWN.

THE MARK CONSISTS OF THE WORD "CLEANTECHOC" WITH A DEVICE CONSISTING OF FOUR ARROWS CREATING A CIRCULAR FORMATION.

FOR PROMOTING THE GOODS AND SERVICES OF OTHERS THROUGH PROVIDING CONSUMER INFORMATION IN THE FIELD OF RENEWABLE AND EFFICIENT ENERGY; AND PROVIDING TARGETED INFORMATION WITH RESPECT TO BUSINESS ADVERTISING AND MARKETING AND EMPLOYMENT OPPORTUNITIES (U.S. CLS. 100, 101 AND 102).

SETH A. RAPPAPORT, EXAMINING ATTORNEY

---

SN 77-861,777. INTERNATIONAL EXHIBITIONS, INC.,  
HOUSTON, TX. FILED 10-30-2009.

**TEXAS HOME & GARDEN MARKET**

THE MARK CONSISTS OF STANDARD CHARACTERS WITHOUT CLAIM TO ANY PARTICULAR FONT, STYLE, SIZE, OR COLOR.

OWNER OF U.S. REG. NOS. 2,328,397, 3,690,694 AND OTHERS.

NO CLAIM IS MADE TO THE EXCLUSIVE RIGHT TO USE "MARKET", APART FROM THE MARK AS SHOWN. SEC. 2(F) AS TO "TEXAS HOME & GARDEN".

FOR ARRANGING AND CONDUCTING TRADE SHOW EXHIBITIONS IN THE FIELD OF HOME AND GARDEN PRODUCTS AND SERVICES (U.S. CLS. 100, 101 AND 102).

FIRST USE 2-12-2010; IN COMMERCE 2-12-2010.

KATINA MISTER, EXAMINING ATTORNEY

**CLASS 35—(Continued).**

SN 77-868,666. AMBLITEL, LLC, SUPERIOR, CO. FILED 11-9-2009.

**AMBLITEL**

THE MARK CONSISTS OF STANDARD CHARACTERS WITHOUT CLAIM TO ANY PARTICULAR FONT, STYLE, SIZE, OR COLOR.

FOR ACCOUNTING AND BILLING SERVICES (U.S. CLS. 100, 101 AND 102).

RAMONA ORTIGA, EXAMINING ATTORNEY

---

SN 77-897,065. THE WALLACE ENTERPRISES, INC.,  
FRANKLIN, TN. FILED 12-18-2009.



NO CLAIM IS MADE TO THE EXCLUSIVE RIGHT TO USE "SURGICAL SPECIALTIES COMPANY", APART FROM THE MARK AS SHOWN.

THE MARK CONSISTS OF THE WORDING "AMERICAN SURGICAL", UNDERLINED, WITH THE WORDING "SPECIALTIES COMPANY" BENEATH THE LINE AND WITH A DESIGN ELEMENT TO THE LEFT OF THE WORDING COMPRISED OF A SQUARE FORMED BY HORIZONTAL STRIPES THAT IS BISECTED BY A DIAGONAL LINE GOING UP AND TO THE RIGHT. THE SQUARE HAS AS STAR TO ITS RIGHT THAT IS HALF IN THE SQUARE AND HALF OUT OF THE SQUARE.

SEC. 2(F) AS TO "AMERICAN SURGICAL SPECIALTIES COMPANY".

FOR WHOLESALE STORE SERVICES, MAIL-ORDER WHOLESALE SERVICES, ON-LINE WHOLESALE STORE SERVICES AND WHOLESALE ORDERING SERVICES IN THE FIELDS OF SURGICAL AND MEDICAL DEVICES, INSTRUMENTS AND EQUIPMENT AND LAPAROSCOPIC SURGICAL AND MEDICAL DEVICES, INSTRUMENTS AND EQUIPMENT (U.S. CLS. 100, 101 AND 102).

FIRST USE 2-1-1997; IN COMMERCE 2-1-1997.

MARILYN IZZI, EXAMINING ATTORNEY

**CLASS 35—(Continued).**

SN 77-917,972. LA CROSSE TECHNOLOGY, LTD., LA CROSSE, WI. FILED 1-22-2010.

## INNOVATIVE HOME PRODUCTS

THE MARK CONSISTS OF STANDARD CHARACTERS WITHOUT CLAIM TO ANY PARTICULAR FONT, STYLE, SIZE, OR COLOR.

OWNER OF U.S. REG. NO. 3,209,806.

NO CLAIM IS MADE TO THE EXCLUSIVE RIGHT TO USE "HOME PRODUCTS", APART FROM THE MARK AS SHOWN.

SEC. 2(F).

FOR PRINT ADVERTISING, NAMELY, PROMOTING THE GOODS AND SERVICES OF OTHERS THROUGH PRINT; ON-LINE RETAIL STORE SERVICES FEATURING GENERAL MERCHANDISE AND GENERAL CONSUMER GOODS (U.S. CLS. 100, 101 AND 102).

FIRST USE 4-30-2004; IN COMMERCE 4-30-2004.  
BENJAMIN OKEKE, EXAMINING ATTORNEY

**CLASS 35—(Continued).**

SN 77-938,721. HELICOPTER.COM LLC, SHERRILLS FORD, NC. FILED 2-18-2010.



NO CLAIM IS MADE TO THE EXCLUSIVE RIGHT TO USE "HELICOPTER.COM", APART FROM THE MARK AS SHOWN.

THE MARK CONSISTS OF THE WORD(S) "HELICOPTER.COM" WITH A STYLIZED HELICOPTER DRAWING AS THE LETTER "T" IN THE WORD "HELICOPTER". THE WORDS "THE SITE FOR VERTICAL FLIGHT" APPEAR UNDER THE LOGO.

FOR ADVERTISING, INCLUDING PROMOTION RELATING TO THE SALE OF ARTICLES AND SERVICES FOR THIRD PARTIES BY THE TRANSMISSION OF ADVERTISING MATERIAL AND THE DISSEMINATION OF ADVERTISING MESSAGES ON COMPUTER NETWORKS; PROVIDING A WEB SITE WHERE USERS CAN POST ITEMS FOR SALE THROUGH ON-LINE CLASSIFIED ADVERTISEMENTS (U.S. CLS. 100, 101 AND 102).

FIRST USE 1-1-2005; IN COMMERCE 1-1-2006.  
ERNEST SHOSHO, EXAMINING ATTORNEY

SN 77-931,411. W2007 STRATOSPHERE PROPCO, L.P., LAS VEGAS, NV. FILED 2-9-2010.



SN 77-939,886. DENVER METRO CONVENTION & VISITORS BUREAU, INC., DENVER, CO. FILED 2-19-2010.

## DENVER ARTS WEEK

THE MARK CONSISTS OF STANDARD CHARACTERS WITHOUT CLAIM TO ANY PARTICULAR FONT, STYLE, SIZE, OR COLOR.

NO CLAIM IS MADE TO THE EXCLUSIVE RIGHT TO USE "ARTS WEEK", APART FROM THE MARK AS SHOWN.

SEC. 2(F).

FOR PROMOTING BUSINESS AND TOURISM IN THE DENVER, COLORADO AREA, NAMELY, PROMOTING ART, THEATER AND MUSIC AT GALLERIES, MUSEUMS, AND PERFORMANCE HALLS (U.S. CLS. 100, 101 AND 102).

FIRST USE 9-0-2007; IN COMMERCE 9-0-2007.  
MARY BOAGNI, EXAMINING ATTORNEY

OWNER OF U.S. REG. NOS. 2,086,400, 2,086,401 AND 3,212,812.

NO CLAIM IS MADE TO THE EXCLUSIVE RIGHT TO USE "LAS VEGAS", APART FROM THE MARK AS SHOWN.

THE MARK CONSISTS OF THE WORDS "SKY JUMP STRATOSPHERE LAS VEGAS" STAGGERED AND VERTICALLY POSITIONED OVER A TARGET.

FOR CUSTOMER LOYALTY SERVICES AND CUSTOMER CLUB SERVICES, FOR COMMERCIAL, PROMOTIONAL AND/OR ADVERTISING PURPOSES; RETAIL GIFT SHOPS (U.S. CLS. 100, 101 AND 102).

PAUL E. FAHRENKOPF, EXAMINING ATTORNEY

**CLASS 35—(Continued).**

SN 77-950,854. FIX LLC, DBA PURE, NEW YORK, NY.  
FILED 3-4-2010.

**PURE PROJECT**

THE MARK CONSISTS OF STANDARD CHARACTERS WITHOUT CLAIM TO ANY PARTICULAR FONT, STYLE, SIZE, OR COLOR.

NO CLAIM IS MADE TO THE EXCLUSIVE RIGHT TO USE "PROJECT", APART FROM THE MARK AS SHOWN.

FOR ASSOCIATION SERVICES, NAMELY, PROMOTING THE INTERESTS OF SOCIALLY AND ENVIRONMENTALLY RESPONSIBLE BUSINESS PRACTICES BY IDENTIFYING AND PROMOTING BUSINESS POLICIES AND PRACTICES THAT BENEFIT EMPLOYEES, COMMUNITIES, THE ECONOMY, THE ENVIRONMENT AND THE COMMERCIAL HEALTH OF THE BUSINESS AND BY COORDINATING BUSINESSES, THE PUBLIC SECTOR AND PUBLIC INTEREST ORGANIZATIONS IN THEIR EFFORTS TO PROMOTE SOCIALLY RESPONSIBLE BUSINESS PRACTICES; BUSINESS SUPERVISION AND BUSINESS AUDITING IN THE FIELD OF ANALYZING THE NATURE AND QUALITY OF BUSINESSES RELATING TO THEIR CONFORMITY WITH PARTICULAR PRACTICES, NORMS, AND STANDARDS; BUSINESS NETWORKING SERVICES, NAMELY, CREATING AND FACILITATING NETWORKS BETWEEN COMPANY REPRESENTATIVES; BUSINESS CONSULTATION SERVICES IN THE FIELD OF SOCIALLY RESPONSIBLE BUSINESS PRACTICES; ARRANGING, ORGANIZING, PLANNING, CONDUCTING AND BUSINESS MANAGEMENT OF SPECIAL EVENTS FOR BUSINESS PURPOSES IN THE FIELD OF SOCIALLY RESPONSIBLE BUSINESS PRACTICES; BUSINESS CONSULTATION SERVICES IN THE FIELD OF DEVELOPING A SOCIALLY JUST AND ENVIRONMENTALLY SUSTAINABLE ECONOMY THROUGH THE COOPERATIVE EFFORTS OF NETWORK MEMBERS TO DEVELOP BUSINESS MODELS THAT ARE MORE SOCIALLY AND ENVIRONMENTALLY CONSCIENTIOUS (U.S. CLS. 100, 101 AND 102).

FIRST USE 1-15-2007; IN COMMERCE 1-30-2007.  
JAY BESCH, EXAMINING ATTORNEY

**CLASS 35—(Continued).**

SN 77-951,391. AUTOMATIONSOLUTIONS, INC., BEVERLY, MA. FILED 3-5-2010.

**iAutomation**

THE MARK CONSISTS OF STANDARD CHARACTERS WITHOUT CLAIM TO ANY PARTICULAR FONT, STYLE, SIZE, OR COLOR.

FOR DISTRIBUTORSHIP SERVICES FEATURING MACHINE AUTOMATION, FLUID POWER, PNEUMATICS AND MOTION CONTROL SYSTEMS AND COMPONENTS; ARRANGING AND CONDUCTING TRADE SHOWS AND EXHIBITIONS IN THE FIELD OF AUTOMATED MANUFACTURING; WHOLESALE DISTRIBUTORSHIP OF PRODUCTS MANUFACTURED BY OTHERS IN THE FIELD OF INDUSTRIAL MACHINE AUTOMATION, NAMELY, ELECTRICAL AND ELECTRONIC SENSORS, ELECTRICAL SWITCHES AND ELECTRICAL SWITCHGEAR, VISION SYSTEMS, INDUSTRIAL ROBOTICS, SAFETY CONTROLLERS, ELECTRIC MOTORS, MECHANICAL ACTUATORS, POWER AMPLIFIERS, FEEDBACK SENSORS ELECTRONIC CONTROLLERS, ELECTRIC RELAYS, NETWORKING, DATA TRANSMITTERS AND RECEIVERS, COMPUTER HARDWARE AND SOFTWARE (U.S. CLS. 100, 101 AND 102).

PAUL F. GAST, EXAMINING ATTORNEY

SN 77-956,660. HAND IN HAND FOR VETERANS, BRANSON, MO. FILED 3-11-2010.

**HAND IN HAND**

THE MARK CONSISTS OF STANDARD CHARACTERS WITHOUT CLAIM TO ANY PARTICULAR FONT, STYLE, SIZE, OR COLOR.

FOR CHARITABLE SERVICES, NAMELY, ORGANIZING AND CONDUCTING VOLUNTEER PROGRAMS AND COMMUNITY SERVICE PROJECTS AIMED AT INCREASING SUPPORT AND MORALE OF FAMILIES OF DECEASED WAR VETERANS, WAR VETERANS, CURRENT MEMBERS AND FUTURE MEMBERS OF THE U.S. MILITARY (U.S. CLS. 100, 101 AND 102).

BRIAN CALLAGHAN, EXAMINING ATTORNEY



**CLASS 35—(Continued).**

SN 77-969,609. BEACON ROOFING SUPPLY, INC., PEABODY, MA. FILED 3-26-2010.

**INDEPENDENT BUILDING  
MATERIALS**

THE MARK CONSISTS OF STANDARD CHARACTERS WITHOUT CLAIM TO ANY PARTICULAR FONT, STYLE, SIZE, OR COLOR.

NO CLAIM IS MADE TO THE EXCLUSIVE RIGHT TO USE "BUILDING MATERIALS", APART FROM THE MARK AS SHOWN.

SEC. 2(F) AS TO "INDEPENDENT".

FOR WHOLESALE DISTRIBUTORSHIPS FEATURING BUILDING MATERIALS; PROVIDING BUSINESS AND COMMERCIAL INFORMATION IN THE FIELD OF BUILDING CONTRACTORS (U.S. CLS. 100, 101 AND 102).

FIRST USE 7-0-2004; IN COMMERCE 7-0-2004.  
DAVID ELTON, EXAMINING ATTORNEY

**CLASS 35—(Continued).**

SN 77-981,495. TANGO CARD, INC., SEATTLE, WA. FILED 3-26-2010.



THE MARK CONSISTS OF THE LETTERS "T" AND "C" BISECTING EACH OTHER VERTICALLY, ENCIRCLED BY TWELVE RECTANGULAR OBJECTS SHAPED LIKE GIFT CARDS.

FOR PROVIDING ONLINE RETAIL STORE SERVICES AND BUSINESS PROMOTION SERVICES, NAMELY, PROVIDING A WEBSITE THAT GIVES USERS THE ABILITY TO BUY STORED VALUE CARDS, TO MANAGE THE USER'S ACCOUNTS ASSOCIATED WITH STORED VALUE CARDS, TO PURCHASE MERCHANDISE USING STORED VALUE CARDS, AND STORED VALUE CARD PROVIDERS THE ABILITY TO PROMOTE AND SELL STORED VALUE GIFT CARDS (U.S. CLS. 100, 101 AND 102).

FIRST USE 11-9-2010; IN COMMERCE 11-9-2010.  
DAVID ELTON, EXAMINING ATTORNEY

SN 78-585,919. THE GREENS/GREEN PARTY USA, EUREKA, CA. FILED 3-11-2005.

SN 77-981,207. JUS-MADE, LP, DALLAS, TX. FILED 8-5-2009.

**THE GREENS/GREEN  
PARTY USA**

**My Drink is Pink**

THE MARK CONSISTS OF STANDARD CHARACTERS WITHOUT CLAIM TO ANY PARTICULAR FONT, STYLE, SIZE, OR COLOR.

FOR PROMOTING PUBLIC AWARENESS OF THE NEED FOR BREAST CANCER RESEARCH; PROMOTING PUBLIC AWARENESS OF BREAST CANCER (U.S. CLS. 100, 101 AND 102).

FIRST USE 2-2-2009; IN COMMERCE 2-2-2009.  
DAVID I, EXAMINING ATTORNEY

THE MARK CONSISTS OF STANDARD CHARACTERS WITHOUT CLAIM TO ANY PARTICULAR FONT, STYLE, SIZE, OR COLOR.

NO CLAIM IS MADE TO THE EXCLUSIVE RIGHT TO USE "PARTY", APART FROM THE MARK AS SHOWN.

SEC. 2(F).

FOR POLITICAL PARTY SERVICES, NAMELY, PROVIDING INFORMATION REGARDING POLITICAL ISSUES; PROVIDING INFORMATION ABOUT POLITICAL ELECTIONS; PROMOTING PUBLIC AWARENESS IN THE FIELDS OF ECOLOGY, SOCIAL JUSTICE, GRASS-ROOTS DEMOCRACY, POLITICAL ORGANIZING, NONVIOLENCE, COMMUNITY BASED POLITICS AND ORGANIZATION, DIVERSITY AND RESPONSIBILITY (U.S. CLS. 100, 101 AND 102).

FIRST USE 9-1-1992; IN COMMERCE 9-1-1992.  
RAUL CORDOVA, EXAMINING ATTORNEY

**CLASS 35—(Continued).**

SN 79-027,193. CORA INVESTMENT PTY LIMITED, AUSTRALIA, FILED 6-15-2006.



OWNER OF INTERNATIONAL REGISTRATION 0894120 DATED 6-15-2006, EXPIRES 6-15-2016.

FOR PROCUREMENT AND PURCHASING SERVICES, NAMELY, PURCHASING OF MARKETING SERVICES, CONTRACT LABOURING SERVICES, ENGINEERING RELATED SERVICES AND RESOURCING SERVICES FOR OTHERS; CATEGORY BUSINESS MANAGEMENT SERVICES, NAMELY, PRINT MANAGEMENT, MAIL MANAGEMENT, DOCUMENT MANAGEMENT, ENGINEERING CAPITAL MANAGEMENT, ENGINEERING MAINTENANCE MANAGEMENT; PROCUREMENT, NAMELY, PURCHASING OF ADVISORY SUPPORT SERVICE, NAMELY, SELECTION OF QUALIFIED SUPPLIERS, SUPPLIER SELECTION, SUPPLIER PERFORMANCE MANAGEMENT ADVICE, TRANSACTION ADVICE; BUSINESS MANAGEMENT AND CONSULTING AND ADVISORY SERVICES; BUSINESS STRATEGIC SOURCING SERVICES, NAMELY, MARKET ANALYSIS, SOURCING STRATEGY ADVICE, NEGOTIATIONS (U.S. CLS. 100, 101 AND 102).

JENNY PARK, EXAMINING ATTORNEY

SN 79-088,790. MARAZZI GROUP S.P.A., ITALY, FILED 9-2-2010.



PRIORITY DATE OF 7-28-2010 IS CLAIMED.  
OWNER OF INTERNATIONAL REGISTRATION 1055098 DATED 9-2-2010, EXPIRES 9-2-2020.

OWNER OF U.S. REG. NOS. 1,195,214 AND 3,029,378.  
THE MARK CONSISTS IN THE LETTERS "AM", STYLIZED IN THE FORM OF BROKEN LINES, IN A SQUARE DEVICE.

FOR SERVICES CONSISTING OF THE BRINGING TOGETHER, FOR THE BENEFIT OF OTHERS, OF A VARIETY OF GOODS, EXCLUDING THE TRANSPORT THEREOF, ENABLING CUSTOMERS TO CONVENIENTLY VIEW AND PURCHASE THOSE GOODS, NAMELY, RETAIL STORE SERVICES FEATURING SANITARY APPARATUS AND INSTALLATIONS, WALL AND FLOOR COVERING MATERIALS, CERAMIC TILES, BATHROOM FURNITURE; ADVERTISING; BUSINESS MANAGEMENT (U.S. CLS. 100, 101 AND 102).

SANI KHOURI, EXAMINING ATTORNEY

**CLASS 35—(Continued).**

SN 85-002,554. HOTSPRING VENTURES LIMITED, LONDON, UNITED KINGDOM, FILED 3-30-2010.



THE MARK CONSISTS OF THE TERMS "WAHANDA" AND "MOBDEAL" WITH A LARGE STAR INSIDE TWO CONCENTRIC CIRCLES AND TWO SMALL STARS IN BETWEEN THE TERMS IN THE MARK. THE OUTER CIRCLE IS IN DOTTED LINES, AND THE INNER CIRCLE IS DRAWN IN A SOLID LINE.

FOR ADMINISTRATION OF A PROGRAM FOR ENABLING PARTICIPANTS TO OBTAIN DISCOUNTS ON PRODUCTS AND SERVICES IN THE FIELDS OF HEALTH, BEAUTY, FITNESS AND WELLBEING; THE BRINGING TOGETHER, FOR THE BENEFIT OF OTHERS, OF A VARIETY OF GOODS AND SERVICES, ENABLING CUSTOMERS TO CONVENIENTLY VIEW AND PURCHASE THOSE GOODS AND SERVICES AT A DISCOUNT FROM AN INTERNET WEB SITE PARTICULARLY SPECIALIZING IN THE MARKETING OF THE SALE OF GOODS AND SERVICES OF OTHERS; PROMOTION AND MARKETING OF HEALTH, BEAUTY, FITNESS AND WELLBEING PRODUCTS AND TREATMENTS THROUGH THE PROVISION OF DISCOUNTS, INCENTIVES, VOUCHERS, REWARDS AND SPECIAL OFFERS; PROMOTING THE GOODS AND SERVICES OF OTHERS BY PROVIDING A WEBSITE FEATURING COUPONS, REBATES, PRICE-COMPARISON INFORMATION, PRODUCT REVIEWS, LINKS TO THE RETAIL WEBSITES OF OTHERS, AND DISCOUNT INFORMATION; PROVIDING ON-LINE DIRECTORY INFORMATION SERVICES ALSO FEATURING HYPERLINKS TO OTHER WEB SITES; ADVERTISING, MARKETING, PROMOTION, ONLINE RETAIL STORE, IN-STORE RETAIL, MAIL ORDER RETAIL, AND CATALOG ORDERING OF HEALTH, BEAUTY AND FITNESS PRODUCTS, COSMETICS, FRAGRANCES AND TOILETRIES, PERFUMES, ESSENTIAL OILS, COSMETICS, DENTIFRICES, DEODORANTS, NON-MEDICATED TOILET PREPARATIONS, PREPARATIONS AND SUBSTANCES FOR USE IN THE CARE AND APPEARANCE OF THE SKIN, HAIR, NAILS, EYES AND TEETH, SOAPS AND CLEANING PREPARATIONS, CREAMS, MEDICINAL AND REMEDIAL PREPARATIONS AND SUBSTANCES, HOMEOPATHIC PREPARATIONS AND SUBSTANCES, PREPARATIONS AND SUBSTANCES DERIVED FROM PLANTS AND FLOWERS FOR USE IN THE TREATMENT OF EMOTIONAL CONDITIONS, PREPARATIONS AND SUBSTANCES FOR MEDICINAL PURPOSES DERIVED FROM PLANTS AND FLOWERS, CANDLES, TOWELS, FLANNELS, BATH ROBES, SPONGES, COMBS, NAIL BRUSHES, HAIR BRUSHES, TOILET BRUSHES, MIRRORS, BATH MATS, SHOWER CAPS, LOOFAHS, BATH PILLOWS, BATH RACKS, PUMICE STONES, FOOT SPAS, HAIRDRYERS, FOOD, CLOTHING, INCLUDING FOOTWEAR AND HEADGEAR, CLOTHING AND HAIR ACCESSORIES, BAGS, MILLINERY, JEWELRY AND IMITATION JEWELRY INCLUDING CLOCKS AND WATCHES, EYEWEAR, SPORTING GOODS AND ARTICLES, TOYS, GAMES AND PLAYTHINGS, CUTLERY, GLASSWARE AND OTHER TABLEWARE, COOKING UTENSILS AND ARTICLES FOR THE PREPARATION OF FOOD AND DRINK, ORNAMENTS FOR THE HOME, CARPETS AND HOME FURNISHINGS, BED LINEN, CONSUMER ELECTRICAL AND ELECTRONIC GOODS AND ACCESSORIES,

**CLASS 35—(Continued).**

GOODS RELATING TO HOME DECORATION, IRON-MONGERY, HAND TOOLS AND INSTRUMENTS FOR DOMESTIC, HOUSEHOLD, KITCHEN AND GARDEN USE, INTERIOR AND GARDEN FURNITURE, STATIONERY, BOOKS, LITERARY MATERIALS, PRINTED MATTER, CHRISTMAS HAMPERS AND DECORATIONS, FOOD AND DRINK; BUSINESS MANAGEMENT; BUSINESS ADMINISTRATION; PROVIDING OFFICE FUNCTIONS; ORGANIZING, ARRANGING AND PROMOTING TRADE FAIRS, EXHIBITIONS AND BUSINESS CONFERENCES; PROMOTING THE GOODS AND SERVICES OF OTHERS BY MEANS OF THE ISSUANCE OF LOYALTY REWARDS CARDS, DISCOUNTS, COUPONS, REBATES, VOUCHERS AND SPECIAL OFFERS FOR THE GOODS OF OTHERS; PROMOTING THE GOODS AND SERVICES OF OTHERS BY PROVIDING DISCOUNTS TO RESTAURANT AND HOTEL SERVICES, CINEMAS, THEATRES, SPORTING EVENTS AND OTHER LEISURE ACTIVITIES, AS PART OF A MEMBERSHIP CLUB SERVICE (U.S. CLS. 100, 101 AND 102).

ALEXANDER L. POWERS, EXAMINING ATTORNEY

SN 85-007,468. SPROCKET MEDIA GROUP, LLC, NORTH ADAMS, MA. FILED 4-6-2010.

## SPROCKETLIST

THE MARK CONSISTS OF STANDARD CHARACTERS WITHOUT CLAIM TO ANY PARTICULAR FONT, STYLE, SIZE, OR COLOR.

FOR ON-LINE CLASSIFIED ADVERTISING SERVICES FEATURING ADVERTISEMENTS FOR SALE OF THIRD PARTY POWER SPORTS PRODUCTS, NAMELY, MOTORCYCLES, ALL TERRAIN VEHICLES (ATVS), UTILITY TERRAIN VEHICLES (UTVS), SNOWMOBILES, SCOOTERS AND SPECIALTY OFF ROAD VEHICLES (U.S. CLS. 100, 101 AND 102).

MARK T. MULLEN, EXAMINING ATTORNEY

SN 85-008,838. GEMVARA INC., LEXINGTON, MA. FILED 4-7-2010.

## GEMVARA

THE MARK CONSISTS OF STANDARD CHARACTERS WITHOUT CLAIM TO ANY PARTICULAR FONT, STYLE, SIZE, OR COLOR.

FOR ONLINE RETAIL STORE SERVICES FEATURING JEWELRY (U.S. CLS. 100, 101 AND 102).

FIRST USE 2-12-2010; IN COMMERCE 2-12-2010.

JOHN E. MICHOS, EXAMINING ATTORNEY

**CLASS 35—(Continued).**

SN 85-012,045. SEAL TRADEMARKS PTY LTD, QUEENSLAND, AUSTRALIA, FILED 4-12-2010.

## BECKER SURF AND SPORT

THE MARK CONSISTS OF STANDARD CHARACTERS WITHOUT CLAIM TO ANY PARTICULAR FONT, STYLE, SIZE, OR COLOR.

NO CLAIM IS MADE TO THE EXCLUSIVE RIGHT TO USE "SURF AND SPORT", APART FROM THE MARK AS SHOWN.

FOR RETAIL STORE, ONLINE, AND WHOLESALE SERVICES FEATURING HEADPHONES, DVDS, COSMETIC BAGS, PENCIL CASES, TIGHTS, SUNGLASSES, EYESHADES, ANTI-GLARE VISORS, GOGGLES FOR SWIMMING, EYEWEAR ACCESSORIES, NAMELY, STRAPS, CHAINS AND CORDS, PROTECTIVE CLOTHING, NAMELY, DRIVING SUITS, STORAGE MEDIA AND APPARATUS FOR RECORDING, STORAGE, TRANSMITTING, REPRODUCING OR PROCESSING DATA, SOUND AND /OR IMAGES, NAMELY, MAGNETIC DATA CARRIERS, TAPES, CASSETTES AND DISCS, AUDIO TAPES, PRE-RECORDED FILMS, NAMELY, VIDEO FILMS, TELECOMMUNICATIONS EQUIPMENT, APPARATUS INSTRUMENTS AND DEVICES, NAMELY, MOBILE TELEPHONES, VIDEO PHONES AND OTHER HANDHELD COMMUNICATIONS APPARATUS, MESSAGING DEVICES, MOBILE TELEPHONE HOUSINGS, MP3 PLAYERS, JEWELRY AND COSTUME JEWELRY, CHARMS, ORNAMENTS, NAMELY, ORNAMENTAL PENDANTS AND ORNAMENTAL PINS, PRECIOUS GEMSTONES AND SEMIPRECIOUS GEMSTONES, WATCHES AND CLOCKS, WATCH ACCESSORIES, NAMELY, WATCH BANDS, WATCH CHAINS, WATCH STRAPS AND WATCH CASES, JEWELRY CASES AND JEWELRY BOXES, MEDALLIONS AND BADGES, BAGS, NAMELY, BEACH BAGS, ALL PURPOSE SPORT BAGS, ALL PURPOSE ATHLETIC BAGS, TOTE BAGS, CARRY-ALL BAGS, SHOPPING BAGS, SHOULDER BAGS, HANDBAGS, CLUTCH BAGS, WAIST PACKS, BACKPACKS, TRAVEL BAGS, TRUNKS, LUGGAGE, CARRY-ON BAGS, GARMENT BAGS FOR TRAVEL, WALLETS, PURSES, KEY CASES, KEY CHAINS, KEY FOBS, KEY RINGS AND KEY TAGS, UMBRELLAS, CLOTHING, NAMELY, T-SHIRTS, SWEATSHIRTS, SHIRTS, BLOUSES, VESTS, SINGLETs AND TOPS, SWEATERS, JACKETS, COATS, PARKAS, PANTS, TROUSERS, JEANS, SHORTS, BOARD SHORTS, OVERALLS, TRACKSUIT TOPS AND TRACKSUIT TROUSERS, SWEATPANTS, DRESSES, SKIRTS, UNDERWEAR, SLEEPWEAR, BELTS, SCARVES, GLOVES, MITTENS, SWIMWEAR, UNDERWEAR, SLEEPWEAR, BELTS, SCARVES, GLOVES, MITTENS FOOTWEAR, HEADGEAR, NAMELY, HATS, CAPS, BEANIES, VISORS, SWIMWEAR, SOCKS, SHOES, BOOTS, SANDALS, THONGS, WETSUITS, WETSUIT VESTS, WETSUIT BOOTS, WETSUIT GLOVES, WETSUIT HOODS, WETSUIT SHORTS AND WETSUIT TOPS, BELT BUCKLES, SPORTING GOODS, NAMELY, SURFBOARDS AND STAND UP PADDLE BOARDS, BODY BOARDS, PARTS AND ACCESSORIES FOR ANY OF THE AFOREGOING GOODS, NAMELY, FINS AND FIN BOXES, DECK GRIPS AND TRACTION PADS FOR BOARDS, BAGS AND COVERS FOR BOARDS, WAX COMBS, LEG ROPES AND LEASHES FOR ANY OF THE AFOREGOING SPORTING GOODS, NOSE GUARDS FOR BOARDS, SWIM FINS, SPORTS GUARDS, NAMELY, ELBOW GUARDS, KNEE GUARDS, WRIST GUARDS, SKATEBOARDS, SKATEBOARD PARTS AND ACCESSORIES, NAMELY, SKATEBOARD DECKS, WHEELS, RAILS, TRUCKS AND BOLTS, SUNSCREEN, TOWELS, STICKERS, BOOKS, CARDS, AND CALENDARS; AND THE BRINGING TOGETHER, FOR THE BENEFIT OF OTHERS, OF A VARIETY OF GOODS, ENABLING CUSTOMERS TO CONVENIENTLY VIEW AND PURCHASE THOSE GOODS IN THE FIELD OF SUNGLASSES, EYESHADES, ANTI-GLARE VISORS, GOGGLES FOR SWIMMING, EYEWEAR ACCESSORIES,

**CLASS 35—(Continued).**

NAMELY, STRAPS, CHAINS AND CORDS, PROTECTIVE CLOTHING, NAMELY, DRIVING SUITS, STORAGE MEDIA AND APPARATUS FOR RECORDING, STORAGE, TRANSMITTING, REPRODUCING OR PROCESSING DATA, SOUND AND /OR IMAGES, NAMELY, MAGNETIC DATA CARRIERS, TAPES, CASSETTES AND DISCS, AUDIO TAPES, PRE-RECORDED FILMS, NAMELY, VIDEO FILMS, TELECOMMUNICATIONS EQUIPMENT, APPARATUS INSTRUMENTS AND DEVICES, NAMELY, MOBILE TELEPHONES, VIDEO PHONES AND OTHER HANDHELD COMMUNICATIONS APPARATUS, MESSAGING DEVICES, MOBILE TELEPHONE HOUSINGS, MP3 PLAYERS, JEWELRY AND COSTUME JEWELRY, CHARMS, ORNAMENTS, NAMELY, ORNAMENTAL PENDANTS AND ORNAMENTAL PINS, PRECIOUS GEMSTONES AND SEMIPRECIOUS GEMSTONES, WATCHES AND CLOCKS, WATCH ACCESSORIES, NAMELY, WATCH BANDS, WATCH CHAINS, WATCH STRAPS AND WATCH CASES, JEWELRY CASES AND JEWELRY BOXES, MEDALLIONS AND BADGES, BAGS, NAMELY, BEACH BAGS, ALL PURPOSE SPORT BAGS, ALL PURPOSE ATHLETIC BAGS, TOTE BAGS, CARRY-ALL BAGS, SHOPPING BAGS, SHOULDER BAGS, HANDBAGS, CLUTCH BAGS, WAIST PACKS, BACKPACKS, TRAVEL BAGS, TRUNKS, LUGGAGE, CARRY-ON BAGS, GARMENT BAGS FOR TRAVEL, WALLETS, PURSES, KEY CASES, KEY CHAINS, KEY FOBS, KEY RINGS AND KEY TAGS, UMBRELLAS, CLOTHING, NAMELY, T-SHIRTS, SWEATSHIRTS, SHIRTS, BLOUSES, VESTS, SINGLETTS AND TOPS, SWEATERS, JACKETS, COATS, PARKAS, PANTS, TROUSERS, JEANS, SHORTS, BOARD SHORTS, OVERALLS, TRACKSUIT TOPS AND TRACKSUIT TROUSERS, SWEATPANTS, DRESSES, SKIRTS, UNDERWEAR, SLEEPWEAR, BELTS, SCARVES, GLOVES, MITTENS, SWIMWEAR, UNDERWEAR, SLEEPWEAR, BELTS, SCARVES, GLOVES, MITTENS FOOTWEAR, HEADGEAR, NAMELY, HATS, CAPS, BEANIES, VISORS, SWIMWEAR, SOCKS, SHOES, BOOTS, SANDALS, THONGS, WETSUITS, WETSUIT VESTS, WETSUIT BOOTS, WETSUIT GLOVES, WETSUIT HOODS, WETSUIT SHORTS AND WETSUIT TOPS; BELT BUCKLES; SPORTING GOODS, NAMELY, SURFBOARDS AND STAND UP PADDLE BOARDS, BODY BOARDS, PARTS AND ACCESSORIES FOR ANY OF THE AFOREGOING GOODS, NAMELY, FINS AND FIN BOXES, DECK GRIPS AND TRACTION PADS FOR BOARDS, BAGS AND COVERS FOR BOARDS, WAX COMBS, LEG ROPES AND LEASHES FOR ANY OF THE AFOREGOING SPORTING GOODS, NOSE GUARDS FOR BOARDS, SWIM FINS, SPORTS GUARDS, NAMELY, ELBOW GUARDS, KNEE GUARDS, WRIST GUARDS, SKATEBOARDS, SKATEBOARD PARTS AND ACCESSORIES, NAMELY, SKATEBOARD DECKS, WHEELS, RAILS, TRUCKS AND BOLTS; SUNSCREEN; TOWELS, STICKERS; BOOKS, CARDS AND CALENDARS; PROMOTING AND ADVERTISING ENTERTAINMENT, SPORTING AND CULTURAL EVENTS OF OTHERS (U.S. CLS. 100, 101 AND 102).

INGA ERVIN, EXAMINING ATTORNEY

**CLASS 35—(Continued).**

SN 85-012,941. PROJECT EVIE, INC., NEW YORK, NY. FILED 4-13-2010.



NO CLAIM IS MADE TO THE EXCLUSIVE RIGHT TO USE "PROJECT", APART FROM THE MARK AS SHOWN.

THE MARK CONSISTS OF THE WORD "PROJECT" IN UPPER AND LOWER CASE POSITIONED ABOVE "EVIE" IN LOWER CASE WITH A PAIR OF LEAVES SUBSTITUTED FOR THE DOT OVER THE "I" AND THE FINAL "E" DEPICTED AS A CURVING WIRE ENDING IN A PLUG.

FOR PUBLIC ADVOCACY TO PROMOTE AWARENESS OF ENVIRONMENTALLY SUSTAINABLE TRAVEL SOLUTIONS INCLUDING ELECTRIC VEHICLES (U.S. CLS. 100, 101 AND 102).

FIRST USE 8-0-2009; IN COMMERCE 8-0-2009.

BENJAMIN OKEKE, EXAMINING ATTORNEY

SN 85-013,238. SCA HYGIENE PRODUCTS AB, GOTEBOG, SWEDEN, FILED 4-13-2010.



NO CLAIM IS MADE TO THE EXCLUSIVE RIGHT TO USE "DIRECT", APART FROM THE MARK AS SHOWN.

THE MARK CONSISTS OF THE WORD "DIRECT" WITH A DESIGN OF A RECTANGLE AND TRIANGLE FORMING A HOUSE LIKE DESIGN, WITH AN ARROW PIERCING THE RECTANGLE AND A SMALL RECTANGLE ON THE SIDE OF THE TRIANGLE FORMING A CHIMNEY.

FOR ON-LINE COMMERCIAL INFORMATION REGARDING SHOPPING FOR HYGIENE PRODUCTS; ELECTRONIC SHOPPING RETAIL SERVICES, NAMELY, ONLINE CATALOG SHOPPING SERVICES IN THE FIELD OF HYGIENE CARE; PROVIDING ON-LINE RETAIL STORE SERVICES IN THE FIELD OF HYGIENE PRODUCTS; RETAIL STORE SERVICES IN THE FIELD OF PRE-RECORDED DVDS CONTAINING EDUCATION, TRAINING, GUIDANCE AND INSTRUCTIONS CONCERNING HEALTH, WELLNESS AND CORE MUSCLE FITNESS, SKIN CARE PRODUCTS, NAMELY, WASH CREAM, PERINEAL WASHCREAM AND CONDITIONER, CLEANSING CREAM, MOISTURIZERS, SKIN LOTION, LIQUID SOAPS, ETHERIC OILS, DISPOSABLE PRE-MOISTENED WASH CLOTHES IMPREGNATED WITH CHEMICALS OR COMPOUNDS FOR PERSONAL HYGIENE FOR USE BY PERSONS SUFFERING FROM INCONTINENCE, WASH GLOVES, DISPOSABLE HYGIENE SHEETS AND UNDERLAYS AND

**CLASS 35—(Continued).**

DIAPERS FOR INCONTINENT PERSONS, DISPOSABLE DIAPERS, SANITARY PADS OF CELLULOSE OR PAPER, PANT DIAPERS FOR INCONTINENCE, SANITARY TOWELS, DIAPERS AND OTHER ABSORBENT ARTICLES FOR SANITARY PURPOSES AND FOR USE BY INCONTINENT PERSONS, CLOTHS FOR WASHING THE BODY, PAPER TOWELS AND PANTS FOR USE BY PERSONS SUFFERING FROM INCONTINENCE; BUSINESS INTERMEDIARY SERVICES IN THE FIELD OF SELLING PRODUCTS AND RENDERING SERVICES IN THE FIELD OF INCONTINENCE PRODUCTS AND PERSONAL HYGIENE PRODUCTS; RETAIL STORE SERVICES PROVIDED BY MEANS OF A GLOBAL COMPUTER NETWORK IN THE FIELD OF INCONTINENCE PRODUCTS AND PERSONAL HYGIENE PRODUCTS; RETAIL ON-LINE STORES IN THE FIELD OF INCONTINENCE PRODUCTS AND PERSONAL HYGIENE PRODUCTS; COMPUTERIZED ON-LINE ORDERING FEATURING GENERAL MERCHANDISE AND GENERAL CONSUMER GOODS (U.S. CLS. 100, 101 AND 102).

REBECCA GILBERT, EXAMINING ATTORNEY

SN 85-014,988. PNP SUPPLY, LLC, VAIL, CO. FILED 4-15-2010.

## PNP Supply, LLC

THE MARK CONSISTS OF STANDARD CHARACTERS WITHOUT CLAIM TO ANY PARTICULAR FONT, STYLE, SIZE, OR COLOR.

NO CLAIM IS MADE TO THE EXCLUSIVE RIGHT TO USE "SUPPLY, LLC", APART FROM THE MARK AS SHOWN.

FOR INDEPENDENT SALES REPRESENTATIVES IN THE FIELD OF PIPE AND FITTINGS FOR SNOWMAKING (U.S. CLS. 100, 101 AND 102).

FIRST USE 4-1-2009; IN COMMERCE 4-1-2009.

GINA HAYES, EXAMINING ATTORNEY

SN 85-015,172. PEERTORIAL LLC, CHICAGO, IL. FILED 4-15-2010.



NO CLAIM IS MADE TO THE EXCLUSIVE RIGHT TO USE "RATE. VOTE. COMMENT.", APART FROM THE MARK AS SHOWN.

THE COLOR(S) BLUE, BLACK, GRAY AND WHITE IS/ARE CLAIMED AS A FEATURE OF THE MARK.

THE MARK CONSISTS OF THE WORDING "PEERTORIAL" WITH THE WORDING "RATE. VOTE. COMMENT."

**CLASS 35—(Continued).**

BELOW, TO THE RIGHT AND IN SMALLER FONT. THE LETTER "O" IN "PEERTORIAL" HAS A BLACK AND GRAY BORDER WITH A BLUE CIRCULAR CENTER SURROUNDED BY A WHITE RING AND IS PARTIALLY COVERED BY A STYLIZED REPRESENTATION OF A COMPUTER CURSOR ARROW IN WHITE WITH A BLACK BORDER AND TO GIVE THE IMPRESSION THAT A USER IS SELECTING AN OPTION. THE REMAINING PORTIONS OF THE WORD "PEERTORIAL" AND "RATE. VOTE. COMMENT." ARE BLACK.

FOR ADVERTISING AND DIRECTORY SERVICES, NAMELY, PROMOTING THE SERVICES OF OTHERS BY PROVIDING A WEB PAGE FEATURING LINKS TO THE WEBSITES OF OTHERS; BANNER ADVERTISING (U.S. CLS. 100, 101 AND 102).

FIRST USE 5-11-2009; IN COMMERCE 7-1-2009.

JULIE WATSON, EXAMINING ATTORNEY

SN 85-016,057. FOUNDRY MEDIA, LLC, NEW YORK, NY. FILED 4-16-2010.

## FOUNDRY

THE MARK CONSISTS OF STANDARD CHARACTERS WITHOUT CLAIM TO ANY PARTICULAR FONT, STYLE, SIZE, OR COLOR.

FOR LITERARY AGENCY SERVICES (U.S. CLS. 100, 101 AND 102).

FIRST USE 1-1-2007; IN COMMERCE 2-1-2007.

MARTHA FROMM, EXAMINING ATTORNEY

SN 85-016,632. ASPEN MANAGEMENT GROUP, AKA ASPEN GROUP, LAKE HARMONY, PA. FILED 4-18-2010.

## TechExplorer

THE MARK CONSISTS OF STANDARD CHARACTERS WITHOUT CLAIM TO ANY PARTICULAR FONT, STYLE, SIZE, OR COLOR.

FOR BUSINESS CONSULTING PERTAINING TO THE IDENTIFICATION OF BUSINESS OPPORTUNITIES (U.S. CLS. 100, 101 AND 102).

FIRST USE 4-6-2010; IN COMMERCE 4-6-2010.

KATHLEEN M. VANSTON, EXAMINING ATTORNEY

**CLASS 35—(Continued).**

SN 85-017,053. BRIDGES, BARBARA, GREENWOOD VIL-  
LAGE, CO. FILED 4-19-2010.



NO CLAIM IS MADE TO THE EXCLUSIVE RIGHT TO  
USE "WOMEN FILM", APART FROM THE MARK AS  
SHOWN.

THE MARK CONSISTS OF THE STYLIZED WORDS  
"WOMEN" AND "FILM" WITH THE DESIGN OF A PLUS  
SYMBOL DIRECTLY BELOW THE LETTER "O" IN "WO-  
MEN" REPRESENTING THE FEMALE GENDER SYMBOL.

FOR MARKETING, ADVERTISING AND PROMOT-  
ING THE GOODS AND SERVICES OF OTHERS; ASSO-  
CIATION SERVICES, NAMELY, PROMOTING THE  
INTERESTS OF FILMMAKERS; PROMOTING A SERIES  
OF FILMS FOR FILMMAKERS; SALES PROMOTION  
SERVICES FOR THIRD PARTIES IN THE NATURE OF  
FILMMAKERS; PROMOTING PUBLIC AWARENESS  
FOR THE NEED OF SOCIAL CHANGE IN THE FIELDS  
OF SOCIAL WELFARE AND WOMEN'S RIGHTS (U.S.  
CLS. 100, 101 AND 102).

FIRST USE 11-30-2007; IN COMMERCE 11-30-2007.  
ADA HAN, EXAMINING ATTORNEY

---

SN 85-017,853. SMITH, KATHRYN, PHOENIX, AZ. FILED 4-  
20-2010.

**TEREBINTH MINISTRIES**

THE MARK CONSISTS OF STANDARD CHARACTERS  
WITHOUT CLAIM TO ANY PARTICULAR FONT, STYLE,  
SIZE, OR COLOR.

NO CLAIM IS MADE TO THE EXCLUSIVE RIGHT TO  
USE "MINISTRIES", APART FROM THE MARK AS  
SHOWN.

FOR BUSINESS ORGANIZATION ASSESSMENTS OF  
ORGANIZATIONAL INFRASTRUCTURE; CHRISTIAN  
SERVICE OPPORTUNITIES FOR USER, CHURCH,  
AND ORGANIZATIONS, NAMELY, DEVELOPING AND  
COORDINATING VOLUNTEER PROJECTS FOR CHARIT-  
ABLE ORGANIZATIONS; BUSINESS ORGANIZATION  
CONSULTATION AND ASSESSMENT SERVICES TO  
HELP TO MAKE USERS, CHURCHES, AND ORGANI-  
ZATIONS BETTER, MORE EFFICIENT AND MORE  
PURPOSE FOCUSED (U.S. CLS. 100, 101 AND 102).

REBECCA POVARCHUK, EXAMINING ATTORNEY

**CLASS 35—(Continued).**

SN 85-018,565. 100% WOMON PRODUCTIONS, INC., BEV-  
ERLY HILLS, CA. FILED 4-20-2010.

**I RUN THIS**

THE MARK CONSISTS OF STANDARD CHARACTERS  
WITHOUT CLAIM TO ANY PARTICULAR FONT, STYLE,  
SIZE, OR COLOR.

FOR MARKETING AND PROMOTION OF ENTER-  
TAINMENT PROPERTIES AND EVENTS (U.S. CLS. 100,  
101 AND 102).

NATALIE POLZER, EXAMINING ATTORNEY

---

SN 85-019,142. KEEPING UNDER CHRIST, INC., AUSTIN,  
TX. FILED 4-21-2010.

**Kappa Chi**

THE MARK CONSISTS OF STANDARD CHARACTERS  
WITHOUT CLAIM TO ANY PARTICULAR FONT, STYLE,  
SIZE, OR COLOR.

FOR ASSOCIATION SERVICES, NAMELY, ORGANIZ-  
ING CHAPTERS OF A FRATERNITY AND PROMOTING  
THE INTERESTS OF THE MEMBERS THEREOF (U.S.  
CLS. 100, 101 AND 102).

FIRST USE 3-1-2000; IN COMMERCE 3-1-2000.

BARBARA GAYNOR, EXAMINING ATTORNEY

---

SN 85-019,158. KEEPING UNDER CHRIST, INC., AUSTIN,  
TX. FILED 4-21-2010.

**Kappa Upsilon Chi**

THE MARK CONSISTS OF STANDARD CHARACTERS  
WITHOUT CLAIM TO ANY PARTICULAR FONT, STYLE,  
SIZE, OR COLOR.

FOR ASSOCIATION SERVICES, NAMELY, ORGANIZ-  
ING CHAPTERS OF A FRATERNITY AND PROMOTING  
THE INTERESTS OF THE MEMBERS THEREOF (U.S.  
CLS. 100, 101 AND 102).

FIRST USE 3-1-2000; IN COMMERCE 3-1-2000.

BARBARA GAYNOR, EXAMINING ATTORNEY

**CLASS 35—(Continued).**

SN 85-019,167. KEEPING UNDER CHRIST, INC., AUSTIN, TX. FILED 4-21-2010.

# KYX

THE MARK CONSISTS OF STANDARD CHARACTERS WITHOUT CLAIM TO ANY PARTICULAR FONT, STYLE, SIZE, OR COLOR.

FOR ASSOCIATION SERVICES, NAMELY, ORGANIZING CHAPTERS OF A FRATERNITY AND PROMOTING THE INTERESTS OF THE MEMBERS THEREOF (U.S. CLS. 100, 101 AND 102).

FIRST USE 2-2-2006; IN COMMERCE 2-2-2006.  
BARBARA GAYNOR, EXAMINING ATTORNEY

SN 85-019,177. KEEPING UNDER CHRIST, INC., AUSTIN, TX. FILED 4-21-2010.

## Keeping Under Christ

THE MARK CONSISTS OF STANDARD CHARACTERS WITHOUT CLAIM TO ANY PARTICULAR FONT, STYLE, SIZE, OR COLOR.

FOR ASSOCIATION SERVICES, NAMELY, ORGANIZING CHAPTERS OF A FRATERNITY AND PROMOTING THE INTERESTS OF THE MEMBERS THEREOF (U.S. CLS. 100, 101 AND 102).

FIRST USE 8-12-2007; IN COMMERCE 8-12-2007.  
BARBARA GAYNOR, EXAMINING ATTORNEY

SN 85-019,527. IRAQ AND AFGHANISTAN VETERANS OF AMERICA, NEW YORK, NY. FILED 4-21-2010.

## WE'VE GOT YOUR BACK

THE MARK CONSISTS OF STANDARD CHARACTERS WITHOUT CLAIM TO ANY PARTICULAR FONT, STYLE, SIZE, OR COLOR.

FOR CHARITABLE SERVICES, NAMELY, ORGANIZING AND CONDUCTING VOLUNTEER PROGRAMS AND COMMUNITY SERVICE PROJECTS AIMED AT INCREASING SUPPORT AND MORALE OF FAMILIES OF DECEASED WAR VETERANS, WAR VETERANS, CURRENT MEMBERS AND FUTURE MEMBERS OF THE U.S. MILITARY (U.S. CLS. 100, 101 AND 102).

CHRISTINA SOBRAL, EXAMINING ATTORNEY

**CLASS 35—(Continued).**

SN 85-020,571. RAZAGHI, PAUL, SAN DIEGO, CA. FILED 4-22-2010.



NO CLAIM IS MADE TO THE EXCLUSIVE RIGHT TO USE "CLEANERS COUPONS", APART FROM THE MARK AS SHOWN.

THE MARK CONSISTS OF A HANGER WITH THE WORDS "CLEANERS COUPONS" INSIDE THE HANGER.

FOR ADVERTISING AND ADVERTISEMENT SERVICES (U.S. CLS. 100, 101 AND 102).  
KELLY TRUSILO, EXAMINING ATTORNEY

SN 85-021,162. TUANGO INC., MONTREAL, QUEBEC, CANADA, FILED 4-22-2010.

# TUANGO

THE MARK CONSISTS OF STANDARD CHARACTERS WITHOUT CLAIM TO ANY PARTICULAR FONT, STYLE, SIZE, OR COLOR.

THE WORDING "TUANGO" HAS NO MEANING IN A FOREIGN LANGUAGE.

FOR PROMOTING THE GOODS AND SERVICES OF OTHERS BY PROVIDING A WEBSITE FEATURING COUPONS, REBATES, PRICE-COMPARISON INFORMATION, PRODUCT REVIEWS, LINKS TO THE RETAIL WEBSITES OF OTHERS AND DISCOUNT INFORMATION; COMPUTER E-COMMERCE SERVICES WHICH ALLOW USERS TO PERFORM ELECTRONIC BUSINESS TRANSACTIONS VIA A GLOBAL COMPUTER NETWORK IN WHICH MULTIPLE PARTIES CAN JOINTLY EXECUTE PURCHASES (U.S. CLS. 100, 101 AND 102).

FIRST USE 2-19-2010; IN COMMERCE 2-19-2010.  
ZACHARY BELLO, EXAMINING ATTORNEY

**CLASS 35—(Continued).**

SN 85-021,914. BEACON ROOFING SUPPLY, INC., PEABODY, MA. FILED 4-23-2010.



NO CLAIM IS MADE TO THE EXCLUSIVE RIGHT TO USE "BUILDING MATERIALS", APART FROM THE MARK AS SHOWN.

THE MARK CONSISTS OF THE WORDS "INDEPENDENT BUILDING MATERIALS" SUPERIMPOSED OVER THE IMAGE OF A HOUSE.

SEC. 2(F) AS TO "INDEPENDENT".

FOR WHOLESALE DISTRIBUTORSHIPS FEATURING BUILDING MATERIALS; PROVIDING BUSINESS AND COMMERCIAL INFORMATION IN THE FIELD OF BUILDING CONTRACTORS (U.S. CLS. 100, 101 AND 102).

FIRST USE 7-0-2004; IN COMMERCE 7-0-2004.  
DAVID ELTON, EXAMINING ATTORNEY

SN 85-022,168. EMPIRE SEVEN LLC, CHESTERFIELD, MI. FILED 4-23-2010.

## ROCK THE RUNWAY

THE MARK CONSISTS OF STANDARD CHARACTERS WITHOUT CLAIM TO ANY PARTICULAR FONT, STYLE, SIZE, OR COLOR.

FOR PROMOTING GOODS AND SERVICES BY ARRANGING FOR FASHION RUNWAY SHOWS TO DISPLAY CLOTHING AND PROMOTE ROCK CONCERTS (U.S. CLS. 100, 101 AND 102).

FIRST USE 7-8-2009; IN COMMERCE 7-8-2009.  
CHRISTINA SOBRAL, EXAMINING ATTORNEY

SN 85-022,241. DEALISH INC., NEW YORK, NY. FILED 4-23-2010.

## Dealish

THE MARK CONSISTS OF STANDARD CHARACTERS WITHOUT CLAIM TO ANY PARTICULAR FONT, STYLE, SIZE, OR COLOR.

FOR PROMOTING THE GOODS AND SERVICES OF OTHERS BY PROVIDING A WEBSITE FEATURING LISTINGS OF A VARIETY OF DEALS, DISCOUNTS, AND SPECIAL OFFERS FROM RESTAURANTS, BARS, AND OTHER DINING ESTABLISHMENTS (U.S. CLS. 100, 101 AND 102).

ERNEST SHOSHO, EXAMINING ATTORNEY

**CLASS 35—(Continued).**

SN 85-023,193. AIRBED & BREAKFAST, INC., SAN FRANCISCO, CA. FILED 4-26-2010.

## AIRBNB

THE MARK CONSISTS OF STANDARD CHARACTERS WITHOUT CLAIM TO ANY PARTICULAR FONT, STYLE, SIZE, OR COLOR.

FOR PROVIDING AN ONLINE INTERACTIVE WEBSITE OBTAINING USERS COMMENTS CONCERNING BUSINESS ORGANIZATIONS, SERVICE PROVIDERS, AND TRAVEL AND SOCIAL ACTIVITIES; PROVIDING INFORMATION, NAMELY, COMPILATIONS, RANKINGS, RATINGS, REVIEWS, REFERRALS AND RECOMMENDATIONS RELATING TO BUSINESS ORGANIZATIONS, SERVICE PROVIDERS, AND TRAVEL AND SOCIAL ACTIVITIES USING A GLOBAL COMPUTER NETWORK; ADVERTISING AND PROMOTION SERVICES AND RELATED CONSULTING; PREPARATION OF CUSTOM OR NON-CUSTOM ADVERTISING FOR BUSINESSES FOR DISSEMINATION VIA THE WEB; DISSEMINATION OF ADVERTISING FOR OTHERS VIA A GLOBAL COMMUNICATIONS NETWORK; ONLINE ADVERTISING SERVICES FOR OTHERS, NAMELY, PROVIDING ADVERTISING SPACE ON INTERNET WEB SITES; PROVIDING A SEARCHABLE ONLINE ADVERTISING GUIDE FEATURING THE GOODS AND SERVICES OF ONLINE VENDORS; PROVIDING A SEARCHABLE ONLINE EVALUATION DATABASE FOR BUYERS AND SELLERS; ADVERTISING AND ADVERTISEMENT SERVICES; CUSTOMER LOYALTY SERVICES AND CUSTOMER CLUB SERVICES FOR COMMERCIAL, PROMOTIONAL AND ADVERTISING PURPOSES; PROMOTING THE GOODS AND SERVICES OF OTHERS; ON-LINE TRADING SERVICES TO FACILITATE THE SALE OF GOODS AND SERVICES BY OTHERS VIA A COMPUTER NETWORK AND PROVIDING EVALUATIVE FEEDBACK AND RATINGS OF SELLERS' GOODS AND SERVICES, THE VALUE AND PRICES OF SELLERS' GOODS AND SERVICES, BUYERS' AND SELLERS' PERFORMANCE, DELIVERY, AND OVERALL TRADING EXPERIENCE IN CONNECTION THEREWITH; ADVERTISING AND ADVERTISEMENT SERVICES; ON-LINE TRADING SERVICES IN WHICH SELLER POSTS ITEMS TO BE AUCTIONED AND BIDDING IS DONE ELECTRONICALLY, AND PROVIDING EVALUATIVE FEEDBACK AND RATINGS OF SELLERS' GOODS AND SERVICES, THE VALUE AND PRICES OF SELLERS' GOODS, BUYERS' AND SELLERS' PERFORMANCE, DELIVERY, AND OVERALL TRADING EXPERIENCE IN CONNECTION THEREWITH; ADVERTISING AND INFORMATION DISTRIBUTION SERVICES, NAMELY, PROVIDING CLASSIFIED ADVERTISING SPACE VIA THE GLOBAL COMPUTER NETWORK; PROVIDING CONSUMER PRODUCT AND SERVICE INFORMATION VIA THE INTERNET; PROVIDING AN ONLINE BUSINESS INFORMATION DIRECTORY ON THE INTERNET; COMPUTERIZED DATABASE MANAGEMENT; PROVIDING ON-LINE COMPUTER DATABASES AND ON-LINE SEARCHABLE DATABASES FEATURING CLASSIFIED LISTINGS AND WANT ADS; CLASSIFIED LISTINGS FOR RENTALS OF A WIDE-VARIETY OF CONSUMER AND BUSINESS GOODS; COMPUTER SERVICES, NAMELY, PROVIDING ON-LINE COMPUTER DATABASES AND ON-LINE SEARCHABLE DATABASES FEATURING CONSUMER INFORMATION ON A WIDE VARIETY OF TOPICS OF GENERAL INTEREST TO THE CONSUMING PUBLIC (U.S. CLS. 100, 101 AND 102).

GIANCARLO CASTRO, EXAMINING ATTORNEY



**CLASS 35—(Continued).**

SN 85-023,229. SEARS BRANDS, LLC, HOFFMAN ESTATES, IL. FILED 4-26-2010.

SEARS FAN SHOP

THE MARK CONSISTS OF STANDARD CHARACTERS WITHOUT CLAIM TO ANY PARTICULAR FONT, STYLE, SIZE, OR COLOR.

OWNER OF U.S. REG. NOS. 2,985,558, 3,809,026 AND OTHERS.

NO CLAIM IS MADE TO THE EXCLUSIVE RIGHT TO USE "FAN SHOP", APART FROM THE MARK AS SHOWN.

FOR RETAIL AND ON-LINE RETAIL STORE SERVICES FEATURING SPORTS MEMORABILIA, APPAREL, JEWELRY, WATCHES AND ACCESSORIES, HOME DECOR INCLUDING BEDDING, DECORATIVE PILLOWS, FURNITURE, LIGHTING, ACCESSORIES AND ARTWORK, OUTDOOR FURNITURE, TABLES, CHAIRS, HAMMOCKS AND UNBRELLAS, GRILLS, COOLERS, YARD GAMES, BOARD GAMES AND TAILGATING ACCESSORIES (U.S. CLS. 100, 101 AND 102).

HELENE LIWINSKI, EXAMINING ATTORNEY

**CLASS 35—(Continued).**

SN 85-025,154. HORNE, MARK J., FT. LAUDERDALE, FL. FILED 4-28-2010.



NO CLAIM IS MADE TO THE EXCLUSIVE RIGHT TO USE "FLYING" AND ".COM", APART FROM THE MARK AS SHOWN.

THE COLOR(S) BLUE, AQUA, BLACK AND GRAY IS/ARE CLAIMED AS A FEATURE OF THE MARK.

THE MARK CONSISTS OF THE WORD "FLYING" STACKED ABOVE ".COM"; A HEADSET DESIGN HANGS ON THE LETTER "G". THE WORD "FLYING" APPEARS IN BLUE AND AQUA WITH GRAY SHADOWS; THE WORD ".COM" APPEARS IN BLUE; AND THE HEADSET APPEARS IN BLACK AND GRAY.

FOR ON-LINE RETAIL STORE SERVICES FEATURING GENERAL AVIATION PRODUCTS AND TRAVEL-RELATED GOODS, NAMELY, CLOTHING AND APPAREL, HEADSETS, TRAVEL BAGS, AND GARMENT BAGS FOR TRAVEL; PROVIDING CONSUMER INFORMATION IN THE FIELD OF GENERAL AVIATION PRODUCTS AND TRAVEL-RELATED GOODS (U.S. CLS. 100, 101 AND 102).

APRIL HESIK, EXAMINING ATTORNEY

SN 85-023,665. DIEX LLC, MIAMI, FL. FILED 4-26-2010.



NO CLAIM IS MADE TO THE EXCLUSIVE RIGHT TO USE "NATURAL", APART FROM THE MARK AS SHOWN.

THE MARK CONSISTS OF A SINGLE LEAF WITH BABY FOOTPRINT IN THE CENTER AND "ATLANTIS NATURAL" WRITTEN IN STYLIZED FONT.

FOR RETAIL STORE AND ON-LINE RETAIL STORE SERVICES FEATURING NATURAL AND ORGANIC BABY PRODUCTS (U.S. CLS. 100, 101 AND 102).

FIRST USE 2-6-2002; IN COMMERCE 2-6-2002.

LEIGH CAROLINE CASE, EXAMINING ATTORNEY

SN 85-025,266. GOCCO CONFEC S.A., 28108 ALCOBENDAS, SPAIN, FILED 4-28-2010.



OWNER OF ERPN CMNTY TM OFC REG. NO. 2153161, DATED 6-30-2003, EXPIRES 6-30-2013.

OWNER OF U.S. REG. NO. 3,275,369.

THE MARK CONSISTS OF THE WORD "GOCCO" IN A STYLIZED FONT.

THE WORDING "GOCCO" HAS NO MEANING IN A FOREIGN LANGUAGE.

FOR (BASED ON INTENT TO USE) RETAIL STORE SERVICES FEATURING CHILDREN'S CLOTHING AND ACCESSORIES; (BASED ON 44(E) BUSINESS MANAGEMENT ADVISORY SERVICES RELATING TO FRANCHISING (U.S. CLS. 100, 101 AND 102).

JOSETTE BEVERLY, EXAMINING ATTORNEY

**CLASS 35—(Continued).**

SN 85-025,868. SHUKLA, SANJAY, BRENTWOOD, TN.  
FILED 4-28-2010.

**TROOSE**

THE MARK CONSISTS OF STANDARD CHARACTERS WITHOUT CLAIM TO ANY PARTICULAR FONT, STYLE, SIZE, OR COLOR.

FOR ARRANGING AND CONDUCTING AUCTIONS; AUCTION MANAGEMENT SERVICES PROVIDED TO OTHERS OVER AN ON-LINE WEB SITE ACCESSED THROUGH A GLOBAL COMPUTER NETWORK; AUCTIONEERING PROVIDED ON THE INTERNET; AUCTIONING VIA TELECOMMUNICATION NETWORKS; BUSINESS MANAGEMENT ASSISTANCE AND PARTICULARLY CARRYING OUT TASKS NECESSARY FOR THE SMOOTH CONDUCT OF SALES BY AUCTION; CARRYING OUT AUCTION SALES; CONDUCTING OF AUCTION SALES; ON-LINE AUCTION SERVICES; ON-LINE AUCTIONEERING SERVICES VIA THE INTERNET; ON-LINE CONSIGNMENT SERVICES WHEREBY GOODS ARE RECEIVED ON CONSIGNMENT FOR AUCTION ON AN ONLINE AUCTION SITE; ORGANIZATION OF INTERNET AUCTIONS; PROVIDING A WEB SITE THAT FEATURES AN ON-LINE MARKET FOR USERS TO LIST OFFERED OR WANTED PERSONAL AND BUSINESS ASSETS AND SKILLS FOR HIRE, RENT, SALE OR AUCTION TRANSACTED ON THE BASIS OF PREDEFINED PERFORMANCE AND CLOSING TERMS AND CONDITIONS; PROVIDING ON-LINE AUCTION SERVICES (U.S. CLS. 100, 101 AND 102).

BARBARA A. GOLD, EXAMINING ATTORNEY

SN 85-026,144. LONGS DRUGS STORES CALIFORNIA, L.L.C., WALNUT CREEK, CA. FILED 4-29-2010.

**LONGS DRUGS**

THE MARK CONSISTS OF STANDARD CHARACTERS WITHOUT CLAIM TO ANY PARTICULAR FONT, STYLE, SIZE, OR COLOR.

OWNER OF U.S. REG. NOS. 2,838,531, 3,065,272 AND 3,368,304.

NO CLAIM IS MADE TO THE EXCLUSIVE RIGHT TO USE "DRUGS", APART FROM THE MARK AS SHOWN.

SEC. 2(F).

FOR ONLINE RETAIL PHARMACY SERVICES (U.S. CLS. 100, 101 AND 102).

APRIL HESIK, EXAMINING ATTORNEY

**CLASS 35—(Continued).**

SN 85-026,984. GALLAGHER, SUZANNE, PLANT CITY, FL.  
FILED 4-30-2010.

**Peace of heART**

THE MARK CONSISTS OF STANDARD CHARACTERS WITHOUT CLAIM TO ANY PARTICULAR FONT, STYLE, SIZE, OR COLOR.

FOR CHARITABLE SERVICES, NAMELY, DEVELOPING AND COORDINATING VOLUNTEER PROJECTS FOR LOCAL COMMUNITIES BY WHICH VOLUNTEERS RECEIVE ARTICLES OF ART AS GIFTS (U.S. CLS. 100, 101 AND 102).

FIRST USE 4-1-2010; IN COMMERCE 4-1-2010.

DAVID C. REIHNER, EXAMINING ATTORNEY

SN 85-027,485. PACK FOR A PURPOSE, INC., RALEIGH, NC.  
FILED 4-30-2010.

**PACK for a PURPOSE**

Small Space. Little Effort. Big Impact.

THE MARK CONSISTS OF THE PHRASE "PACK FOR A PURPOSE" WITH THE "O" IN "PURPOSE" REPLACED BY A GLOBE DESIGN, ABOVE THE TAGLINE "SMALL SPACE. LITTLE EFFORT. BIG IMPACT."

FOR CHARITABLE SERVICES, NAMELY, PROVIDING AN INFORMATIONAL WEBSITE TO FACILITATE CHARITABLE CONTRIBUTIONS BY PROMOTING TO TRAVELERS INFORMATION ON NEEDED SUPPLIES FOR COMMUNITY-BASED PROJECTS AROUND THE WORLD, TO MEET THE NEEDS OF CHARITABLE PROJECTS AT DESTINATIONS TO WHICH SUCH PERSONS ARE TRAVELLING (U.S. CLS. 100, 101 AND 102).

FIRST USE 12-17-2009; IN COMMERCE 12-17-2009.

HENRY S. ZAK, EXAMINING ATTORNEY

SN 85-029,534. KOTTER INTERNATIONAL, INC., CAMBRIDGE, MA. FILED 5-4-2010.

**KOTTER INTERNATIONAL**

THE MARK CONSISTS OF STANDARD CHARACTERS WITHOUT CLAIM TO ANY PARTICULAR FONT, STYLE, SIZE, OR COLOR.

NO CLAIM IS MADE TO THE EXCLUSIVE RIGHT TO USE "INTERNATIONAL", APART FROM THE MARK AS SHOWN.

SEC. 2(F).

FOR BUSINESS MANAGEMENT CONSULTATION, BUSINESS CONSULTING SERVICES AND PROVIDING A WEBSITE FEATURING NEWS AND INFORMATION IN THE FIELDS OF ORGANIZATIONAL CHANGE MANAGEMENT, AND EXECUTIVE AND LEADERSHIP DEVELOPMENT; ONLINE RETAIL STORE SERVICES FEATURING BOOKS AND DVDS (U.S. CLS. 100, 101 AND 102).

FIRST USE 2-0-2010; IN COMMERCE 2-2-2010.

TASNEEM HUSSAIN, EXAMINING ATTORNEY

**CLASS 35—(Continued).**

SN 85-029,778. KOTTER INTERNATIONAL, INC., CAMBRIDGE, MA. FILED 5-4-2010.

# KOTTER

THE MARK CONSISTS OF STANDARD CHARACTERS WITHOUT CLAIM TO ANY PARTICULAR FONT, STYLE, SIZE, OR COLOR.

SEC. 2(F).

FOR BUSINESS MANAGEMENT CONSULTATION, BUSINESS CONSULTING SERVICES AND PROVIDING A WEBSITE FEATURING NEWS AND INFORMATION IN THE FIELDS OF ORGANIZATIONAL CHANGE MANAGEMENT, AND EXECUTIVE AND LEADERSHIP DEVELOPMENT; ONLINE RETAIL STORE SERVICES FEATURING BOOKS AND DVDS (U.S. CLS. 100, 101 AND 102).

FIRST USE 12-0-2002; IN COMMERCE 12-0-2002.  
TASNEEM HUSSAIN, EXAMINING ATTORNEY

---

SN 85-030,091. THEORIE INC., SAN DIEGO, CA. FILED 5-4-2010.

# betwixt

THE MARK CONSISTS OF STANDARD CHARACTERS WITHOUT CLAIM TO ANY PARTICULAR FONT, STYLE, SIZE, OR COLOR.

FOR RETAIL STORE AND ON-LINE RETAIL STORE SERVICES FEATURING CLOTHING, CLOTHING ACCESSORIES, FOOTWEAR AND HEADWEAR, JEWELRY, AND BAGS (U.S. CLS. 100, 101 AND 102).

SEAN CROWLEY, EXAMINING ATTORNEY

---

SN 85-030,462. MEMYLOGOS.COM, LLC, NAPLES, FL. FILED 5-5-2010.

# MeMyLogos

THE MARK CONSISTS OF STANDARD CHARACTERS WITHOUT CLAIM TO ANY PARTICULAR FONT, STYLE, SIZE, OR COLOR.

FOR ADVERTISING AND MARKETING OF THE LOGOS OF THIRD-PARTY BRAND OWNERS, NAMELY, PROVIDING AN ONLINE DATABASE OF THIRD-PARTY LOGOS, AND PROVIDING A WEBSITE FEATURING THIRD-PARTY LOGOS OF BRAND OWNERS THAT ENABLES USERS TO CREATE A CUBE OF THEIR FAVORITE LOGOS THAT CONTAIN LINKS TO THE WEBSITES OF THE OWNERS OF THE LOGOS, ALL FOR THE PURPOSE OF UPLOADING TO AND SHARING SAID LOGOS WITH USERS ON A SOCIAL NETWORKING WEBSITE (U.S. CLS. 100, 101 AND 102).

MARTHA SANTOMARTINO, EXAMINING ATTORNEY

**CLASS 35—(Continued).**

SN 85-036,648. QUORUM HEALTH RESOURCES, LLC, FRANKLIN, TN. FILED 5-12-2010.



The logo for Quorum Purchasing Advantage features the word "Quorum" in a large, blue, serif font with a red horizontal line underneath it. Below "Quorum" is the phrase "PURCHASING ADVANTAGE" in a smaller, blue, sans-serif font.

OWNER OF U.S. REG. NOS. 3,257,760 AND 3,737,811.

NO CLAIM IS MADE TO THE EXCLUSIVE RIGHT TO USE "PURCHASING", APART FROM THE MARK AS SHOWN.

THE COLOR(S) BLUE AND RED IS/ARE CLAIMED AS A FEATURE OF THE MARK.

THE MARK CONSISTS OF THE WORDS "QUORUM PURCHASING ADVANTAGE" IN STYLIZED BLUE LETTERS WITH A RED HORIZONTAL LINE BETWEEN THE WORDING "QUORUM" AND "PURCHASING ADVANTAGE". THE COLOR WHITE IS FOR BACKGROUND PURPOSES ONLY AND IS NOT PART OF THE MARK.

FOR HEALTH CARE CONSULTATION SERVICES, NAMELY, ADMINISTRATION OF DISCOUNT PROGRAMS THAT ENABLE PARTICIPATING HEALTH CARE FACILITY MEMBERS TO PURCHASE GOODS AND SERVICES AT FAVORABLE PRICES AND TERMS (U.S. CLS. 100, 101 AND 102).

MEGHAN REINHART, EXAMINING ATTORNEY

---

SN 85-037,218. ESTERS, EDWARD, SAN JOSE, CA. FILED 5-13-2010.

# HEMP FUSION

THE MARK CONSISTS OF STANDARD CHARACTERS WITHOUT CLAIM TO ANY PARTICULAR FONT, STYLE, SIZE, OR COLOR.

NO CLAIM IS MADE TO THE EXCLUSIVE RIGHT TO USE "HEMP", APART FROM THE MARK AS SHOWN.

FOR ADVERTISING AND MARKETING SERVICES, NAMELY, PROMOTING THE GOODS AND SERVICES OF RETAIL BUSINESSES (U.S. CLS. 100, 101 AND 102).

BERYL GARDNER, EXAMINING ATTORNEY

---

SN 85-039,261. DALE BAKERY, LLC, DBA FRED'S BAKERY, LOS ANGELES, CA. FILED 5-14-2010.

# FRED'S BAKERY

THE MARK CONSISTS OF STANDARD CHARACTERS WITHOUT CLAIM TO ANY PARTICULAR FONT, STYLE, SIZE, OR COLOR.

NO CLAIM IS MADE TO THE EXCLUSIVE RIGHT TO USE "BAKERY", APART FROM THE MARK AS SHOWN. FOR RETAIL BAKERY SHOPS (U.S. CLS. 100, 101 AND 102).

FIRST USE 0-0-1951; IN COMMERCE 0-0-1951.

EMILY CHUO, EXAMINING ATTORNEY

**CLASS 35—(Continued).**

SN 85-048,479. (ADD)VENTURES, PROVIDENCE, RI. FILED 5-26-2010.

(add)thropology

THE MARK CONSISTS OF STANDARD CHARACTERS WITHOUT CLAIM TO ANY PARTICULAR FONT, STYLE, SIZE, OR COLOR.  
FOR ADVERTISING AND ADVERTISEMENT SERVICES (U.S. CLS. 100, 101 AND 102).  
FIRST USE 5-15-2009; IN COMMERCE 5-15-2009.  
DAVID H. STINE, EXAMINING ATTORNEY

SN 85-049,388. PATANE, DIEGO, SAN DIEGO, CA. FILED 5-27-2010.



NO CLAIM IS MADE TO THE EXCLUSIVE RIGHT TO USE "GLOBAL BUSINESS UNION", APART FROM THE MARK AS SHOWN.  
THE COLOR(S) BLUE, BROWN AND KHAKI IS/ARE CLAIMED AS A FEATURE OF THE MARK.  
THE MARK CONSISTS OF A STYLIZED IMAGE OF A BLUE BOX WITH A STYLIZED IMAGE OF A BROWN AND KHAKI "L" SHAPED BOX BELOW THE BLUE BOX THAT WRAPS AROUND THE TWO SIDES OF THE BLUE BOX WITH A SHADOW APPEARING BELOW THE STYLIZED BOXES, THE BOXES ARE FOLLOWED ON THE RIGHT BY THE WORD "GLOBAL" IN KHAKI AND THE WORDS "BUSINESS UNION" IN KHAKI, WITH THE WORDS "START BUILDING YOUR BUSINESS" APPEARING IN BLUE BELOW THE WORDS "GLOBAL BUSINESS UNION".  
FOR BUSINESS CONSULTATION (U.S. CLS. 100, 101 AND 102).  
FIRST USE 10-10-2009; IN COMMERCE 10-10-2009.  
TRACY CROSS, EXAMINING ATTORNEY

**CLASS 35—(Continued).**

SN 85-060,344. AMERICAN DIABETES ASSOCIATION, INC., ALEXANDRIA, VA. FILED 6-11-2010.

MES AMERICANO DE LA DIABETES

THE MARK CONSISTS OF STANDARD CHARACTERS WITHOUT CLAIM TO ANY PARTICULAR FONT, STYLE, SIZE, OR COLOR.  
OWNER OF U.S. REG. NO. 2,558,354.  
NO CLAIM IS MADE TO THE EXCLUSIVE RIGHT TO USE "MES", APART FROM THE MARK AS SHOWN.  
THE ENGLISH TRANSLATION OF "MES AMERICANO DE LA DIABETES" IN THE MARK IS "AMERICAN DIABETES MONTH".  
SEC. 2(F).  
FOR PROMOTING PUBLIC AWARENESS TO DIABETES, NAMELY, PROVIDING A NATIONWIDE PUBLIC AWARENESS PROGRAM CONDUCTED DURING THE MONTH OF NOVEMBER TO RAISE AWARENESS TO THE PUBLIC THAT DIABETES COMPLICATIONS CAN BE PREVENTED (U.S. CLS. 100, 101 AND 102).  
FIRST USE 11-1-1998; IN COMMERCE 11-1-1998.  
KIM SAITO, EXAMINING ATTORNEY

SN 85-064,276. BIOINVENTORS & ENTREPRENEURS NETWORK LLC, WARREN, NJ. FILED 6-16-2010.

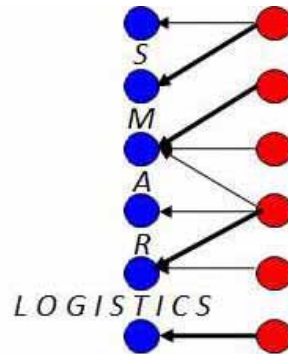

NO CLAIM IS MADE TO THE EXCLUSIVE RIGHT TO USE "LOGISTICS", APART FROM THE MARK AS SHOWN.  
THE COLOR(S) BLACK, BLUE AND RED IS/ARE CLAIMED AS A FEATURE OF THE MARK.  
THE MARK CONSISTS OF TWO COLUMNS OF SIX CIRCLES EACH WITH ARROWS FROM THE RIGHT COLUMN POINTING TO THE LEFT COLUMN AND THE LETTERS "S M A R T" APPEARING VERTICALLY BETWEEN EACH CIRCLE OF THE LEFT COLUMN, WITH THE LETTERS "L O G I S T I C S" HORIZONTALLY COMPLETING THE WORD "LOGISTICS" BETWEEN THE FIFTH AND SIXTH CIRCLES OF THE LEFT COLUMN. THE CIRCLES IN THE LEFT COLUMN ARE BLUE, THE CIRCLES IN THE RIGHT COLUMN ARE RED, THE ARROWS AND LETTERING ARE BLACK.  
FOR MANAGING INVENTORIES AND DISTRIBUTION OF BLOOD PRODUCTS IN THE NATURE OF ACTING AS AN INTERMEDIARY BETWEEN BLOOD SUPPLIES AND INVENTORIES AND ENTITIES SEEKING BLOOD PRODUCTS (U.S. CLS. 100, 101 AND 102).  
WANDA KAY PRICE, EXAMINING ATTORNEY

**CLASS 35—(Continued).**

SN 85-064,442. MARSHALL CONVENTION & VISITORS BUREAU, AKA CITY OF MARSHALL, TEXAS, MARSHALL, TX. FILED 6-16-2010.

**CLASS 35—(Continued).**

SN 85-066,124. STUDIO SEVEN, WILMINGTON, OH. FILED 6-18-2010.

# STUDIO SEVEN

## Birthplace of Boogie Woogie

THE MARK CONSISTS OF STANDARD CHARACTERS WITHOUT CLAIM TO ANY PARTICULAR FONT, STYLE, SIZE, OR COLOR.  
FOR ADVERTISING, MARKETING AND PROMOTION SERVICES (U.S. CLS. 100, 101 AND 102).  
FIRST USE 1-25-2010; IN COMMERCE 5-29-2010.  
KARANENDRA S. CHHINA, EXAMINING ATTORNEY

THE MARK CONSISTS OF STANDARD CHARACTERS WITHOUT CLAIM TO ANY PARTICULAR FONT, STYLE, SIZE, OR COLOR.

FOR PROMOTING PUBLIC AWARENESS OF ENVIRONMENTAL MATTERS; PROMOTING PUBLIC AWARENESS OF CULTURAL MATTERS, NAMELY, THE NEED FOR LOCAL ART SPACES AND STRUCTURES, FUNDING FOR UNDERPRIVILEGED YOUTH AND ELDERLY PARTICIPATION IN LOCAL VISUAL, PERFORMING AND HISTORICAL ART EVENTS, PRESENTATIONS, AND CLASSES/EDUCATION; PROMOTING PUBLIC AWARENESS OF COMMUNITY OUTREACH AND COORDINATION, NAMELY, CULTURAL/ARTIST EXCHANGE PROGRAMS, NEIGHBORHOOD MEETINGS AND FAMILY HISTORY SHARES, MICRO COOPERATIVES, DIRECTION GRANTS, AND SOCIAL SCHOLARSHIPS; PROMOTING PUBLIC AWARENESS OF URBAN AND RURAL DEVELOPMENT, NAMELY, AFFORDABLE AND GREEN HOUSING, SUSTAINABLE DEVELOPMENT, MICRO AGRICULTURE, ADJUSTING CARBON FLOW, WATER COLLECTION, IRRIGATION, AND ENTERTAINMENT, SOCIALLY CONSCIOUS AND ORGANIZED SMALL BUSINESS PLACEMENT, AND PRESERVING RURAL AREAS WHILE PROVIDING A VIABLE GREEN INDUSTRY (U.S. CLS. 100, 101 AND 102).  
DAVID TAYLOR, EXAMINING ATTORNEY

SN 85-064,761. COLLEGETOWN RELOCATION LLC, PRINCETON, NJ. FILED 6-16-2010.

SN 85-067,246. RICH & HUNTER HOLDINGS, LLC, TROY, OH. FILED 6-21-2010.

## YOU CAN GET THERE FROM HERE

# XEBEC3 METAL ROOFING SUPPLIES

THE MARK CONSISTS OF STANDARD CHARACTERS WITHOUT CLAIM TO ANY PARTICULAR FONT, STYLE, SIZE, OR COLOR.  
FOR PROVIDING INFORMATION ABOUT AND MAKING REFERRALS IN THE FIELD OF CONSUMER PRODUCTS AND SERVICES FOR RETAIL SERVICES CONCERNING PRODUCTS, SERVICES, EVENTS, ACTIVITIES, ATTRACTIONS AND FACILITIES IN PARTICULAR GEOGRAPHIC LOCATIONS, ALL OF THE ABOVE INTENDED FOR INDIVIDUALS AND COMPANIES THAT ARE IN THE PROCESS OF RELOCATING TO A NEW LOCATION (U.S. CLS. 100, 101 AND 102).  
FIRST USE 11-30-2009; IN COMMERCE 11-30-2009.  
KATHERINE E. HALMEN, EXAMINING ATTORNEY

THE MARK CONSISTS OF STANDARD CHARACTERS WITHOUT CLAIM TO ANY PARTICULAR FONT, STYLE, SIZE, OR COLOR.  
NO CLAIM IS MADE TO THE EXCLUSIVE RIGHT TO USE "METAL ROOFING SUPPLIES", APART FROM THE MARK AS SHOWN.  
FOR WHOLESALE STORES AND DISTRIBUTORSHIPS FEATURING ROOFING AND RELATED BUILDING MATERIALS AND SUPPLIES, NAMELY, METAL ROOFING PANELS, METAL ROOFING TRIMS, FASTENERS, SYNTHETIC UNDERLAYMENT AND SEALANTS (U.S. CLS. 100, 101 AND 102).  
LAURIE KAUFMAN, EXAMINING ATTORNEY

**CLASS 35—(Continued).**

SN 85-067,924. INTERLINE BRANDS, INC., JACKSONVILLE, FL. FILED 6-21-2010.

**COPPERFIELD**

THE MARK CONSISTS OF STANDARD CHARACTERS WITHOUT CLAIM TO ANY PARTICULAR FONT, STYLE, SIZE, OR COLOR.

OWNER OF U.S. REG. NO. 1,583,068.  
SEC. 2(F).

FOR CATALOG AND ONLINE ORDERING SERVICES IN THE FIELD OF CHIMNEY SWEEP ARTICLES AND ACCESSORIES, VENTILATION AND CHIMNEY MAINTENANCE PRODUCTS, HEARTH PRODUCTS, AND GAS AND SOLID FUEL BURNING APPLIANCES (U.S. CLS. 100, 101 AND 102).

FIRST USE 5-20-2000; IN COMMERCE 5-20-2000.  
CHARLES L. JENKINS, EXAMINING ATTORNEY

SN 85-068,376. FLASH SEATS, LLC, CLEVELAND, OH. FILED 6-22-2010.

**THE FUTURE OF TICKETING  
TODAY**

THE MARK CONSISTS OF STANDARD CHARACTERS WITHOUT CLAIM TO ANY PARTICULAR FONT, STYLE, SIZE, OR COLOR.

FOR OPERATING AN ONLINE MARKETPLACE WHICH ENABLES THE PRIMARY OR SECONDARY SALE, OR BARTERING, OF TICKETS TO ENTERTAINMENT OR SPORTING EVENTS; COMPUTERIZED ONLINE ORDERING SERVICES FOR ACCEPTING ORDERS FOR TICKETS TO ENTERTAINMENT AND SPORTING EVENTS (U.S. CLS. 100, 101 AND 102).

FIRST USE 9-27-2007; IN COMMERCE 9-27-2007.  
MICHAEL LITZAU, EXAMINING ATTORNEY

SN 85-068,435. EQUINE GLOBE LLC, CHARLOTTESVILLE, VA. FILED 6-22-2010.

**EQUINEGLOBE**

THE MARK CONSISTS OF STANDARD CHARACTERS WITHOUT CLAIM TO ANY PARTICULAR FONT, STYLE, SIZE, OR COLOR.

OWNER OF U.S. REG. NO. 3,648,403.

FOR ON-LINE RETAIL STORE SERVICES FEATURING EQUESTRIAN CLOTHING, HATS AND CAPS, SHIRTS AND ACCESSORIES (U.S. CLS. 100, 101 AND 102).

KIM MONINGHOFF, EXAMINING ATTORNEY

**CLASS 35—(Continued).**

SN 85-068,582. INTERLINE BRANDS, INC., JACKSONVILLE, FL. FILED 6-22-2010.

**MAINTENANCE USA**

THE MARK CONSISTS OF STANDARD CHARACTERS WITHOUT CLAIM TO ANY PARTICULAR FONT, STYLE, SIZE, OR COLOR.

OWNER OF U.S. REG. NO. 2,327,939.  
SEC. 2(F).

FOR CATALOG AND ONLINE ORDERING SERVICES IN THE FIELD OF MAINTENANCE, REPAIR AND OPERATIONS PRODUCTS, NAMELY, APPLIANCES, CABINETRY, ELECTRICAL PRODUCTS, FLOOR COVERINGS, HARDWARE, HOSPITALITY SUPPLIES, HVAC PRODUCTS, JANITORIAL AND SANITARY PRODUCTS, LAWN AND GARDEN PRODUCTS, LIGHTING PRODUCTS, PAINT AND SUNDRIES, PLUMBING PRODUCTS, POOL PRODUCTS, SECURITY PRODUCTS, TOOLS AND EQUIPMENT, AND WINDOW COVERINGS (U.S. CLS. 100, 101 AND 102).

FIRST USE 10-17-2000; IN COMMERCE 10-17-2000.  
CHARLES L. JENKINS, EXAMINING ATTORNEY

SN 85-074,439. NATIONAL FAMILY PARTNERSHIP, MIAMI, FL. FILED 6-29-2010.



THE MARK CONSISTS OF A WAVING RIBBON, BEGINNING WITH THE FORKED END OF THE RIBBON FOLLOWED BY A BEND IN THE RIBBON, WITH THE WORDS "SEE THE CONNECTIONS..." IN UNDERCASE IN THE NEXT SECTION OF THE RIBBON, FOLLOWED BY ANOTHER BEND IN THE RIBBON AND THE WORDS "CHOICES = CONSEQUENCES" IN UNDERCASE IN THE LAST SECTION OF THE RIBBON FOLLOWED BY THE OTHER FORKED END, AND THE WORDS "I AM DRUG-FREE" IN CAPITAL LETTERS UNDERNEATH THE RIBBON, WITH ALL LETTERS IN A HANDWRITING-STYLE FONT.

FOR PROMOTING PUBLIC AWARENESS OF THE NEED FOR DRUG ABUSE PREVENTION (U.S. CLS. 100, 101 AND 102).

FIRST USE 2-1-2010; IN COMMERCE 2-1-2010.  
TARA PATE, EXAMINING ATTORNEY

**CLASS 35—(Continued).**

SN 85-074,527. SWIFT TECHNICAL HOLDINGS LIMITED, ENFIELD MIDDLESEX, UNITED KINGDOM, FILED 6-30-2010.

SWIFT WORLDWIDE RESOURCES

THE MARK CONSISTS OF STANDARD CHARACTERS WITHOUT CLAIM TO ANY PARTICULAR FONT, STYLE, SIZE, OR COLOR.

NO CLAIM IS MADE TO THE EXCLUSIVE RIGHT TO USE "WORLDWIDE RESOURCES", APART FROM THE MARK AS SHOWN.

FOR RECRUITMENT AND EMPLOYMENT PLACEMENT SERVICES; EMPLOYMENT AGENCY SERVICES, NAMELY, FURNISHING OF EMPLOYEES ON A PERMANENT OR CONTRACT BASIS TO PERSONS OR PLACES OF BUSINESS REQUIRING PERMANENT, PART TIME OR TEMPORARY PERSONNEL IN THE FIELDS OF ENGINEERS, ENVIRONMENTAL PROFESSIONALS, SAFETY PROFESSIONALS, ESTIMATORS, OPERATORS, PLANNERS, ANALYSTS, PROJECT MANAGERS, LAWYERS, SURVEYORS, TECHNICIANS, INSPECTORS, MECHANICS, HUMAN RESOURCE PERSONNEL AND ACCOUNTANTS (U.S. CLS. 100, 101 AND 102).

FIRST USE 6-14-2010; IN COMMERCE 6-14-2010.  
EMILY CHUO, EXAMINING ATTORNEY

**CLASS 35—(Continued).**

SN 85-077,990. DRIVEN FORWARD, LLC, DBA DRIVEN FORWARD, OAKTON, VA. FILED 7-5-2010.



THE COLOR(S) GREEN, GREY IS/ARE CLAIMED AS A FEATURE OF THE MARK.

THE MARK CONSISTS OF A GREEN SWOOSH LINE THAT FADES TO GREY, THE WORDS "DRIVEN FORWARD" IN GREEN, AND THE TAG-LINE "DRIVING SUCCESS" IN GREY.

FOR BUSINESS MANAGEMENT CONSULTATION (U.S. CLS. 100, 101 AND 102).

FIRST USE 7-1-2009; IN COMMERCE 7-1-2009.  
FONG HSU, EXAMINING ATTORNEY

SN 85-078,200. 338 INDUSTRIES, LLC, AUSTIN, TX. FILED 7-6-2010.

SN 85-075,775. BIOINVENTORS & ENTREPRENEURS NETWORK LLC, WARREN, NJ. FILED 7-1-2010.

SMA | RT LOGISTICS

NO CLAIM IS MADE TO THE EXCLUSIVE RIGHT TO USE "LOGISTICS", APART FROM THE MARK AS SHOWN.

THE MARK CONSISTS OF THE WORDING "SMA RT LOGISTICS" WITH A VERTICAL LINE BETWEEN "SMA" AND "RT".

FOR MANAGING INVENTORIES AND DISTRIBUTION OF BLOOD PRODUCTS IN THE NATURE OF ACTING AS AN INTERMEDIARY BETWEEN BLOOD SUPPLIES AND INVENTORIES AND ENTITIES SEEKING BLOOD PRODUCTS (U.S. CLS. 100, 101 AND 102).

WANDA KAY PRICE, EXAMINING ATTORNEY

THE POLITICAL FORCE

THE MARK CONSISTS OF STANDARD CHARACTERS WITHOUT CLAIM TO ANY PARTICULAR FONT, STYLE, SIZE, OR COLOR.

NO CLAIM IS MADE TO THE EXCLUSIVE RIGHT TO USE "POLITICAL", APART FROM THE MARK AS SHOWN.

FOR PROVIDING A WEBSITE FOR USE IN MANAGING A POLITICAL CAMPAIGN; PROVIDING AN ONLINE SEARCHABLE DATABASE FOR POLITICAL CAMPAIGNS WHICH ALLOW USERS TO COLLECT AND ANALYZE POLITICAL INFORMATION ELECTRONICALLY; PROVIDING A WEBSITE FEATURING INFORMATION ABOUT POLITICAL ISSUES (U.S. CLS. 100, 101 AND 102).

INGRID C. EULIN, EXAMINING ATTORNEY

**CLASS 35—(Continued).**

SN 85-078,260. 338 INDUSTRIES, LLC, AUSTIN, TX. FILED 7-6-2010.

**POLITICAL FORCE**

THE MARK CONSISTS OF STANDARD CHARACTERS WITHOUT CLAIM TO ANY PARTICULAR FONT, STYLE, SIZE, OR COLOR.

NO CLAIM IS MADE TO THE EXCLUSIVE RIGHT TO USE "POLITICAL", APART FROM THE MARK AS SHOWN.

FOR PROVIDING A WEBSITE FOR USE IN MANAGING A POLITICAL CAMPAIGN; PROVIDING AN ON-LINE SEARCHABLE DATABASE FOR POLITICAL CAMPAIGNS WHICH ALLOW USERS TO COLLECT AND ANALYZE POLITICAL INFORMATION ELECTRONICALLY; PROVIDING A WEBSITE FEATURING INFORMATION ABOUT POLITICAL ISSUES (U.S. CLS. 100, 101 AND 102).

INGRID C. EULIN, EXAMINING ATTORNEY

SN 85-078,513. XP INNOVATION, LLC, DBA DAN'S COMP, MT. VERNON, IN. FILED 7-6-2010.

**Damageinc**

THE MARK CONSISTS OF STANDARD CHARACTERS WITHOUT CLAIM TO ANY PARTICULAR FONT, STYLE, SIZE, OR COLOR.

FOR COMPUTERIZED ON-LINE RETAIL STORE SERVICES IN THE FIELD OF BAGS, WALLET, SUNGLASSES AND PORTABLE MUSIC EQUIPMENT (U.S. CLS. 100, 101 AND 102).

PAUL F. GAST, EXAMINING ATTORNEY

SN 85-078,537. SALESLABS, INC., NEW YORK, NY. FILED 7-6-2010.

**ONTARGET**

THE MARK CONSISTS OF STANDARD CHARACTERS WITHOUT CLAIM TO ANY PARTICULAR FONT, STYLE, SIZE, OR COLOR.

FOR PROVISION OF BUSINESS INFORMATION, AND PUBLIC OPINION POLLING VIA THE INTERNET, ON SUBJECT MATTER RELATED TO REVENUE GROWTH (U.S. CLS. 100, 101 AND 102).

PRISCILLA MILTON, EXAMINING ATTORNEY

**CLASS 35—(Continued).**

SN 85-080,299. ELLIE'S ECO HOME STORE, INC., BOULDER, CO. FILED 7-8-2010.

**N.E.W.**

THE MARK CONSISTS OF STANDARD CHARACTERS WITHOUT CLAIM TO ANY PARTICULAR FONT, STYLE, SIZE, OR COLOR.

FOR WHOLESALE DISTRIBUTORSHIP SERVICES, FEATURING NATURAL SPONGES, FOOD CONTAINERS, REUSABLE STORAGE BAGS, FOOD CLEANERS, BABY BOTTLES AND PACIFIERS, LUNCH BOXES, GROCERY AND SHOPPING BAGS, SANDWICH AND SNACK BAGS, PET FOOD, FERTILIZERS, GARDEN WEEDERS AND CULTIVATORS, LAUNDRY DETERGENT, ALUMINUM FOIL, BAKING SHEETS, COFFEE FILTERS, KITCHEN GLOVES, DINNER PLATES, DRINKING CUPS, GARBAGE BAGS, HOUSEHOLD CLEANERS, DRAIN CLEANERS, ALL-PURPOSE CLEANERS, GLASS CLEANERS, BATHROOM CLEANERS, DISHWASHING LIQUID, HOUSEHOLD CLEANERS AND DEGREASERS, AIR FRESHENERS, PROVIDED TO RETAILERS, GOVERNMENT AGENCIES AND OTHER BUSINESSES (U.S. CLS. 100, 101 AND 102).

DAVID TAYLOR, EXAMINING ATTORNEY

SN 85-090,447. TOBIN, DAN, DES PLAINES, IL. AND WHITLEY, ANDY, LAKE IN THE HILLS, IL. FILED 7-22-2010.



THE COLOR(S) WHITE, BLACK, PURPLE, LIGHT BLUE, TAN, BROWN-GREEN, PEACH, BEIGE, GRAY, RED, ORANGE, YELLOW, GREEN, BLUE, LAVENDER AND VIOLET IS/ARE CLAIMED AS A FEATURE OF THE MARK.

THE MARK CONSISTS OF THE BLUE WORDING "PAL 2 PAL" COUPLED WITH A CURVED LINE ON THE RIGHT AND LEFT OF THE NUMBER 2 AND A CURVED LINE BELOW THE NUMBER 2 FORMING A FACE. BELOW THE WORDING IS AN OVAL OUTLINED IN BLUE WITH A LIGHT BLUE SKY WITH WHITE AND LIGHT BLUE CLOUDS, TAN HILLS, GREEN GRASS AND THREE BLACK BIRDS. INSIDE THE OVAL THERE IS A TURTLE, BIRD, GIRAFFE, MONKEY, UNICORN, LION, AND HIPPO. THE GREEN TURTLE HAS WHITE AND BLACK EYES, A LIGHT GREEN EYEBROW, A LIGHT GREEN STOMACH, BLACK DOTS FOR THE NOSE, A BLACK MOUTH AND A BROWN-GREEN SHELL. THE RED AND PEACH BIRD HAS WHITE AND BLACK EYES, A YELLOW BEAK, PEACH EYEBROWS, AND BLACK LINES FOR THE NOSE. THE ORANGE AND BROWN GIRAFFE HAS BROWN HORNS AND HAIR, A RED AND BLACK MOUTH, WHITE AND BLACK EYES, A BROWN NOSE, AND ORANGE AND BROWN EARS. THE BROWN AND BEIGE MONKEY HAS



**CLASS 35—(Continued).**

WHITE AND BLACK EYES, BLACK DOTS ON THE NOSE AND A BLACK LINE FOR THE MOUTH. THE LAVENDER UNICORN HAS WHITE AND BLACK EYES, PURPLE HAIR, LAVENDER EARS, BLACK EYELASHES, AND A YELLOW HORN WITH BLACK LINES. THE GRAY HIPPO HAS WHITE AND BLACK EYES AND WHITE TEETH. THE TAN LION HAS A BROWN MANE AND EYEBROWS, WHITE AND BLACK EYES, BROWN AND TAN EARS, A RED TONGUE, AND A BLACK MOUTH WITH WHITE TEETH.

FOR RETAIL STORE SERVICES FEATURING CHILDREN'S AND YOUTH CLOTHING, CLOTHING PRODUCTS AND CLOTHING ACCESSORIES; ON-LINE RETAIL STORE SERVICES FEATURING CHILDREN'S AND YOUTH CLOTHING, CLOTHING PRODUCTS AND CLOTHING ACCESSORIES (U.S. CLS. 100, 101 AND 102).  
RAMONA ORTIGA, EXAMINING ATTORNEY

---

SN 85-090,598. TOM JOYNER ONLINE EDUCATION, LLC, DALLAS, TX. FILED 7-22-2010.

**STUDENT SUPPORT PLUS**

THE MARK CONSISTS OF STANDARD CHARACTERS WITHOUT CLAIM TO ANY PARTICULAR FONT, STYLE, SIZE, OR COLOR.

NO CLAIM IS MADE TO THE EXCLUSIVE RIGHT TO USE "STUDENT SUPPORT", APART FROM THE MARK AS SHOWN.

FOR EDUCATIONAL COUNSELING SERVICES FOR ASSISTING STUDENTS WITH PLANNING AND PREPARING FOR FURTHER EDUCATION, NAMELY, ASSISTING AND ADVISING STUDENTS IN THE FIELD OF DEGREE OR CERTIFICATE COURSE COMPLETION AND RE-ENROLLMENT; PROVIDING EDUCATION INFORMATION, ASSISTANCE, TECHNIQUES AND SUPPORT FOR ONLINE STUDENTS IN THE FIELD OF TIME MANAGEMENT, COURSE ACTION PLANS AND STRATEGIES (U.S. CLS. 100, 101 AND 102).

GINA HAYES, EXAMINING ATTORNEY

---

SN 85-092,377. STILLMAN KLIEGER, INC, AKA ATTORNEY'S COUNSEL, NEW YORK, NY. FILED 7-25-2010.

**PAY OFF**

THE MARK CONSISTS OF STANDARD CHARACTERS WITHOUT CLAIM TO ANY PARTICULAR FONT, STYLE, SIZE, OR COLOR.

FOR RESUME WRITING SYSTEM, NAMELY, COUNSELING REGARDING RESUME WRITING AND PREPARATION (U.S. CLS. 100, 101 AND 102).

KATHLEEN LORENZO, EXAMINING ATTORNEY

**CLASS 35—(Continued).**

SN 85-093,145. MOTION INDUSTRIES, INC., BIRMINGHAM, AL. FILED 7-26-2010.



**GENERAL TOOL & SUPPLY CO.**  
INDUSTRIAL TOOL & SUPPLY DIVISION

NO CLAIM IS MADE TO THE EXCLUSIVE RIGHT TO USE "TOOL & SUPPLY CO." AND "INDUSTRIAL TOOL & SUPPLY DIVISION", APART FROM THE MARK AS SHOWN.

THE MARK CONSISTS OF THE FIGURE OF A GENERAL IN A SALUTING POSE TO THE LEFT OF THE WORDS "GENERAL TOOL & SUPPLY CO." IN BOLDED CAPITAL LETTERS ABOVE A RUNNING LINE, BELOW WHICH ARE THE WORDS "INDUSTRIAL TOOL & SUPPLY DIVISION" IN CAPITAL LETTERS.

FOR DISTRIBUTORSHIPS IN THE FIELD OF INDUSTRIAL HARDWARE, INDUSTRIAL SUPPLIES, JANITORIAL SUPPLIES, PAPER PRODUCTS, SAFETY POWER TOOLS, STATIONARY TOOLS, SAFETY EQUIPMENT, SAFETY SUPPLIES, WELDING EQUIPMENT, WELDING SUPPLIES, MATERIAL HANDLING, MEASUREMENT PRODUCTS, AND MAINTENANCE, REPAIR, OPERATING AND PRODUCTION SUPPLIES (U.S. CLS. 100, 101 AND 102).

FIRST USE 0-0-1930; IN COMMERCE 0-0-1930.  
FRANK LATTUCA, EXAMINING ATTORNEY

---

SN 85-093,551. THEAS.COM, LLC, DBA HANGITUP.COM, LEE'S SUMMIT, MO. FILED 7-27-2010.

THE COLOR(S) GRAY AND ORANGE IS/ARE CLAIMED AS A FEATURE OF THE MARK.

THE MARK CONSISTS OF THE WORDS "HANG" AND "UP" IN ORANGE WITH THE WORD "IT" IN GRAY BETWEEN THEM, WITH THE BOTTOM OF THE LETTER "G" IN THE WORD "HANG" APPEARING SIMILAR TO A HANGER.

FOR OPERATING ON-LINE MARKETPLACES FEATURING NEW AND USED CLOTHING, SHOES AND ACCESSORIES; OPERATING ON-LINE MARKETPLACES FOR SELLERS OF GOODS AND/OR SERVICES (U.S. CLS. 100, 101 AND 102).

DOMINIC J. FERRAIUOLO, EXAMINING ATTORNEY

**CLASS 35—(Continued).**

SN 85-093,574. THEAS.COM, LLC, DBA HANGITUP.COM, LEE'S SUMMIT, MO. FILED 7-27-2010.



THE COLOR(S) ORANGE IS/ARE CLAIMED AS A FEATURE OF THE MARK.

THE MARK CONSISTS OF THE LETTER "G" IN ORANGE WITH THE BOTTOM OF THE LETTER "G" APPEARING SIMILAR TO A HANGER.

FOR OPERATING ON-LINE MARKETPLACES FEATURING NEW AND USED CLOTHING, SHOES AND ACCESSORIES; OPERATING ON-LINE MARKETPLACES FOR SELLERS OF GOODS AND/OR SERVICES (U.S. CLS. 100, 101 AND 102).

DOMINIC J. FERRAIUOLO, EXAMINING ATTORNEY

SN 85-094,774. NORTHERN SAFETY CO., INC., FRANKFORT, NY. FILED 7-28-2010.



THE MARK CONSISTS OF THE LETTERS "NSI" IN BOLD CAPITAL LETTERS WITH AN OVAL CIRCLE STARTING ABOVE THE "N" AND CIRCLING RIGHT, AROUND THE BOTTOM AND STOPPING UNDER THE LEFT SIDE OF THE "N".

FOR WHOLESALE MAIL ORDER CATALOG, MAIL ORDER AND ONLINE RETAIL STORE SERVICES VIA THE INTERNET FEATURING INDUSTRIAL AND SAFETY PRODUCTS, NAMELY, BIOHAZARD PROTECTION KITS FOR INDIVIDUALS, BIOHAZARD CLEANUP AND DISPOSAL EQUIPMENT, NAMELY, DISINFECTANT, FLUID SOLIDIFIER AND DECONTAMINANT, SHARPS DISPOSAL CONTAINERS, WASTE CONTAINERS AND LINERS, WASTE DISPOSAL BAGS, CLEAN UP KITS AND PACKS, BURN RELIEF FIRST AID KITS, BURN BLANKETS, DRESSINGS FOR BURNS, TOPICAL TREATMENTS FOR BURNS, CPR FIRST AID EQUIPMENT, NAMELY, CPR MASKS, FACE SHIELDS, PORTABLE EMERGENCY OXYGEN CYLINDERS, DISPOSABLE RESUSCITATOR, DRUG AND ALCOHOL TESTING KITS, EMERGENCY EYE WASH AND EMERGENCY SHOWERS, EMERGENCY PREPAREDNESS EQUIPMENT AND KITS, EMERGENCY STRETCHERS AND BACKBOARDS, AUTOMATED EXTERNAL DEFIBRILLATORS, EMERGENCY COMMAND VESTS, EMERGENCY SURVIVAL WRAPS, HEAT STRESS RELIEF PRODUCTS, NAMELY, DRINK MIXES, COOLERS, CUPS, FREEZER POPS, COOLERS AND ACCESSORIES, HEAT STRESS ELECTROLYTE TABLETS, AND HEAT RELIEF CLOTHING AND ACCESSORIES, OUTDOOR SUN AND PEST PROTECTION AND SKIN CARE RELIEF PREPARATIONS, TICK REMOVAL KITS, SNAKE

**CLASS 35—(Continued).**

BITE LANCET AND SUCTION PUMP, PEST CONTROL REPELLENTS, INDUSTRIAL ADHESIVES AND SEALANTS, NAMELY, EPOXY ADHESIVES, SILICONE ADHESIVES, SPRAY ADHESIVES, INSTANT ADHESIVES, THREADLOCKERS AND SEALANTS, REPAIR EPOXIES, REPAIR URETHANES, GLUE, METHACRYLATE ADHESIVES, GEL ADHESIVES, SILICONE SEALANTS, GASKET MAKERS, RUBBER COATING SEALANTS, TAPE ADHESIVES, BATTERY CHARGERS, COMMUNICATION SYSTEMS, NAMELY, TWO-WAY RADIOS AND ACCESSORIES, NAMELY, HEADSETS, BATTERIES AND BATTERY CHARGERS, LISTEN-ONLY EARPLUGS AND LAPEL MICROPHONE, FANS, NAMELY, PEDESTAL AND FLOOR FANS, AIR CIRCULATING BLOWERS, FANS AND MOUNTS, CEILING FANS, MISTING AND EVAPORATIVE COOLING FANS, EXHAUST FANS, WORK STATION FANS, FLASHLIGHTS AND BATTERIES, GENERATORS, GROUNDS MAINTENANCE EQUIPMENT, NAMELY, SHOVELS, SCOOPS, SPADES, RAKES, SNOW TOOLS, LITTER COLLECTION TOOLS, POST HOLE DIGGERS, MAGNETIC PUSH SWEEPERS, WHEELBARROWS, SPREADERS, BIG WHEEL CART, SHEARS, GAS TRIMMERS, HEATERS, NAMELY, KEROSENE, OIL FORCED AIR, PROPANE FORCED AIR, RADIANT, CONVENTION, PORTABLE ELECTRIC, INFRARED, FAN FORCED, COMBINED RADIANT AND FAN FORCED, INDUSTRIAL STORAGE SYSTEMS, NAMELY, BIN SYSTEMS, STORAGE BINS, STACK CONTAINERS, STACK AND NEST TOTES, DIVIDABLE GRID CONTAINERS, WIRE SHELVING BIN SYSTEM, TIER LOCKERS, PLASTIC BULK CONTAINERS, LADDERS, LIGHTING, NAMELY, CONFINED SPACE LIGHTING, LIGHTED EMERGENCY EXIT SIGNS, POWER FAILURE LIGHTING, WORK LIGHTS, FLASHLIGHTS, DOCK LIGHTING, PORTABLE LIGHTING, BULBS, LAMPS, LIGHT BULB CHANGING TOOL, AEROSOL LUBRICANTS AND GREASE, ELECTRICAL AND TEMPERATURE METERS AND TESTERS, PAINTS, PRESSURE WASHERS, PUMPS, NAMELY, WATER, FUEL, FUEL STORAGE AND TRANSFER SYSTEMS, TRANSFER PUMPS, SAFETY AND SECURITY MIRRORS, SPRAYERS, TAPES, NAMELY, MARKING, DUCT, ELECTRICAL, MASKING, MOUNTING, PACKAGING, ANTI-SLIP FLOOR AND STAIR, INVISIBLE AND TRANSPARENT, TARPS, TIE-DOWNS, AND CARGO CONTROL, NAMELY, RUBBER AND BUNGEE CORDS, WATER HOSES, WELDING EQUIPMENT AND SUPPLIES, CIGARETTE RECEPTACLES AND BUTT CANS, CLEANING PRODUCTS, NAMELY, HAND AND SURFACE CLEANING TOWELS, CLEANERS AND DEGREASERS, SOAPS, LOTIONS, WIPES, SQUEEGEES, SCRAPERS, BRUSHES, HYGIENE AND RESTROOM SUPPLIES, JANITORIAL CHEMICALS AND EQUIPMENT, NAMELY, CLEANERS, DEGREASERS, DISINFECTANTS, DEODORIZERS, BRUSHES, BROOMS, MOPS, SWEEPERS, WET MOPS AND BUCKETS, JANITORIAL AND HOUSEKEEPING SIGNS, MICRO-FIBER CLOTHS, BUCKETS AND PAILS, VACUUMS AND FLOOR MAINTENANCE EQUIPMENT, NAMELY, WET DRY VACUUMS, SHOP VACUUMS, DRY VACUUMS, CRITICAL CLEANING VACUUMS, FLOOR MACHINES AND BURNISHERS, FLOOR AND UTILITY PADS, CARPET DRYERS, VACUUM FILTERS, SLEEVES AND TOOL KITS, WASTE AND RECYCLING CONTAINERS, NAMELY, INDOOR WASTE, RECYCLING AND TRASH CONTAINERS AND SIGNS, OUTDOOR WASTE RECEPTACLES, CIGARETTE BUTT CANS AND TRASH CONTAINERS, WASTE CONTAINERS AND CARTS, COMMERCIAL WASTE AND TRASH CONTAINER LINERS, INDUSTRIAL ALL-PURPOSE WIPES ON A ROLL AND ROLL DISPENSER, CLEANING WIPES, CASTERS, CRANES, NAMELY, GANTRY LIFTING CRANES, JIB LIFTING CRANES, PIPE LIFTING GRABS, DIE LIFTING TONGS, DOCK EQUIPMENT, NAMELY, WHEEL CHOCKS, BUMPERS, TRAILER STABILIZER JACKS, RAMPS AND WHEEL RISERS, DOCK SIGNALING EQUIPMENT, FORK TRUCK ATTACHMENTS, HANDLING EQUIPMENT, NAMELY, PALLET JACKS, MATERIAL HANDLING CARTS, DELIVERY BICYCLES, CARGO TRICYCLES, MATERIAL HANDLING TRUCKS, DOLLIES, TROLLEYS, MATERIAL HANDLING CAROUSELS, CONVEYORS AND LIFTS, LIFTING JACKS AND HOISTS, LIFTING SLINGS AND CLAMPS FOR USE IN MACHINE SHOPS AND CONSTRUCTION SITES, SHOP EQUIPMENT, NAMELY, WORK STATIONS, TABLES, TOOL TOTES, WORK BENCHES, AND OFFICE EQUIPMENT, CONFINED SPACE RESCUE AND RE-

**CLASS 35—(Continued).**

TRIEVAL TRIPOD AND ARM HOIST SYSTEMS, VENTILATION BLOWERS, VENTS, ENTRY COMMUNICATION SYSTEMS, MANHOLE ENTRY AND EGRESS EQUIPMENT, CONFINED SPACE TRAINING AND COMPLIANCE MATERIALS, NAMELY, TRAINING PROGRAM VIDEO AND HANDBOOKS, SCRIPTED TRAINING INSTRUCTIONS, RECORD-KEEPING FORMS AND SIGNS, ERGONOMIC PRODUCTS, NAMELY, BODY SUPPORTS AND KNEE PADS AND MATS, WRIST SUPPORTS, WRAPS AND BRACES, ELBOW SLEEVES AND TENNIS ELBOW SUPPORTS, PULL-ON ANKLE SUPPORTS, WORKPLACE MATTING, EYE PROTECTION, NAMELY, SAFETY GLASSES, SAFETY GOGGLES, LENS CLEANERS, LENS SOLUTIONS, FALL PROTECTION, NAMELY, FALL HARNESS AND LANYARD COMBOS, FALL HARNESSES, SHOCK ABSORBING LANYARDS, POSITIONING LANYARDS, SELF-RETRACTING LIFELINES, HORIZONTAL LIFELINES, ROOF ANCHORS, ANCHORAGE CONNECTORS, CARABINERS, ROPE AND ROPE GRABS, REBAR CHAIN ASSEMBLY, RETRACTABLE LANYARDS, FALL PROTECTION TRAINING VIDEOS AND SIGNS, RESTRAINT AND WORK POSITIONING BELTS, LADDER SAFETY SYSTEMS, SAFETY NETS, REBAR ASSEMBLIES, NAMELY, REBAR ANCHORING STRAPS AND REBAR CAPS, RESCUE KITS AND EQUIPMENT, SAFETY FOOTWEAR, GAS MONITORS, GAS METERS, GAS DETECTORS, GAS SAMPLE PUMPS, PROTECTIVE CLOTHING FOR HEAD AND HANDS, HARD HATS, WELDING HELMETS, FACE SHIELDS, HEARING PROTECTION, PROTECTIVE CLOTHING, RESPIRATORY PROTECTION, CAN AND DRUM PUMPS, FUNNELS, VENTS, VALVES, GROUNDING AND BONDING CABLE AND CLAMPS, DRUM WRENCHES AND DEHEADERS, DRUM AND PAIL COVERS, INSERTS AND LIDS, STORAGE DRUM AND CYLINDER HANDLING EQUIPMENT, ELECTRICAL SAFETY EQUIPMENT, INDUSTRIAL EQUIPMENT AND LAPTOP CASES, FIRE SAFETY EQUIPMENT, LOCKOUT TAGOUT AND SECURITY EQUIPMENT, NAMELY, LOCKOUT TAGOUT SAFETY CENTERS AND KITS, PADLOCKS, ADJUSTABLE CABLE LOCKOUT, PLUG LOCKOUT PROTECTORS, LOCKOUT, TAGOUT HASPS AND TAGS, MACHINE GUARDS, SAFETY CABINETS, SAFETY CANS, SECONDARY CONTAINMENT PLATFORMS AND UNITS, SPILL PALLETS, SALVAGE DRUMS, OVERPACK DRUMS, DRUM DISPENSING RACKS, WORK STATIONS, RAILROAD PANS, POP-UP POOLS, TANKER AND DRUM BERMS, SORBENTS AND SPILL CONTROL EQUIPMENT, NAMELY, DRAIN PLUGS AND COVERS, TRAFFIC SAFETY SUPPLIES, WORKER SAFETY TRAINING VIDEOS, POSTERS, SOFTWARE AND MANUALS, SHIPPING SUPPLIES, ABRASIVES, AIR COMPRESSORS, HAND TOOLS, NAMELY, TAPE MEASURES, KNIVES AND CUTTERS, REPLACEMENT BLADES, TOOL SHEATHS, PLUMBING TOOLS, PNEUMATIC TOOLS, POWER TOOLS AND POWER TOOL ACCESSORIES, TOOL ORGANIZERS (U.S. CLS. 100, 101 AND 102).

ANGELA M. MICHELI, EXAMINING ATTORNEY

**CLASS 35—(Continued).**

SN 85-095,130. KELLOGG NORTH AMERICA COMPANY, BATTLE CREEK, MI. FILED 7-28-2010.

**POP-TARTS WORLD**

THE MARK CONSISTS OF STANDARD CHARACTERS WITHOUT CLAIM TO ANY PARTICULAR FONT, STYLE, SIZE, OR COLOR.

OWNER OF U.S. REG. NOS. 791,514, 3,790,914 AND OTHERS.

FOR RETAIL STORE AND ONLINE RETAIL STORE SERVICES FEATURING COLLECTIBLES, APPAREL AND APPAREL ACCESSORIES, JEWELRY AND FASHION ACCESSORIES, TOYS AND GAMES, KITCHEN IMPLEMENTS, HOUSEWARES, DISHWARE, BEVERAGEWARE, POSTCARDS, OFFICE AND STATIONERY AND PHOTO SUPPLIES, GREETING CARDS, INDIVIDUAL FOOD PRODUCT KEEPERS, LUNCH BAGS, KEY CHAINS, CELL PHONE COVERS, LAPTOP COVERS, TOTE BAGS, TOASTERS, GIFTS IN THE NATURE OF NOVELTY FOOD BOXES FEATURING PHOTOGRAPHS OF CONSUMERS AND OTHER GIFT NOVELTIES AND FOOD PRODUCTS (U.S. CLS. 100, 101 AND 102).

MICHAEL GAAFAR, EXAMINING ATTORNEY

SN 85-095,520. SEARS BRANDS, LLC, HOFFMAN ESTATES, IL. FILED 7-29-2010.

**SEARS. BE THE SANTA YOU WANT TO BE.**

THE MARK CONSISTS OF STANDARD CHARACTERS WITHOUT CLAIM TO ANY PARTICULAR FONT, STYLE, SIZE, OR COLOR.

OWNER OF U.S. REG. NOS. 1,529,006, 2,621,139 AND OTHERS.

FOR RETAIL AND ONLINE RETAIL DEPARTMENT STORE SERVICES; RETAIL AND ONLINE RETAIL STORE SERVICES FEATURING APPAREL, TOYS, HOLIDAY GIFTS AND HOLIDAY-THEMED GOODS (U.S. CLS. 100, 101 AND 102).

ALLISON SCHRODY, EXAMINING ATTORNEY

SN 85-098,790. HERITAGE KENNEL CLUB, LLC, MAYNARDVILLE, TN. FILED 8-3-2010.

**HKC**

THE MARK CONSISTS OF STANDARD CHARACTERS WITHOUT CLAIM TO ANY PARTICULAR FONT, STYLE, SIZE, OR COLOR.

FOR MAINTAINING A REGISTRY OF BREEDS IN THE FIELD OF DOGS (U.S. CLS. 100, 101 AND 102).

FIRST USE 2-22-2010; IN COMMERCE 2-22-2010.

MICHAEL TANNER, EXAMINING ATTORNEY

**CLASS 35—(Continued).**

SN 85-099,378. VICAR + TART, SAN FRANCISCO, CA. FILED 8-3-2010.



THE COLOR(S) LIGHT BLUE AND DARK BLUE IS/ARE CLAIMED AS A FEATURE OF THE MARK.

THE MARK CONSISTS OF THE WORDS "VICAR +" APPEARING IN DARK BLUE AND THE WORD "TART" WITH AN IMAGE OF A TV APPEARING IN LIGHT BLUE.

FOR ADVERTISING; BUSINESS MANAGEMENT; BUSINESS ADMINISTRATION; PROVIDING OFFICE FUNCTIONS FOR OTHERS INCLUDING ASSISTING WITH THE MANAGEMENT AND OPERATIONS OF A COMMERCIAL ENTERPRISE, HELPING MANAGE THE BUSINESS AFFAIRS OR COMMERCIAL FUNCTIONS OF AN INDUSTRIAL OR COMMERCIAL ENTERPRISE AND PROVIDING SERVICES RENDERED BY ADVERTISING ESTABLISHMENTS, NAMELY, PROMOTING THE GOODS AND SERVICES OF OTHERS THROUGH ALL COMMUNICATIONS MEANS, IN CLASS 035 (U.S. CLS. 100, 101 AND 102).

FIRST USE 6-1-2008; IN COMMERCE 6-1-2008.

SAIMA MAKHDOOM, EXAMINING ATTORNEY

SN 85-099,545. MELTON, SHENILLE L, DBA ICHOOSE2LIVE, PHILADELPHIA, PA. FILED 8-3-2010.



THE COLOR(S) BLUE, GREEN, AND BLACK IS/ARE CLAIMED AS A FEATURE OF THE MARK.

THE MARK CONSISTS OF A STYLIZED BLACK LOWER CASE LETTER I WITH A BLUE TITTLE OVER THE "I", A STYLIZED BLACK CAPITAL LETTER "C", STYLIZED BLACK LOWER CASE LETTERS HOOSE, A STYLIZED GREEN NUMBER "2", STYLIZED BLUE WORD LIVE WITH A LITTLE BLUE MAN JUMPING IN THE AIR IN PLACE OF THE LETTER I IN LIVE, STYLIZED BLACK WORDS (WITH EACH FIRST LETTER CAPITALIZED) "BECAUSE THAT'S WHAT SURVIVORS DO"! WITH THE WORD SURVIVORS IN BOLD LETTERS

FOR ON-LINE RETAIL STORE SERVICES FEATURING CLOTHING (U.S. CLS. 100, 101 AND 102).

FIRST USE 5-15-2010; IN COMMERCE 5-15-2010.

MARY CRAWFORD, EXAMINING ATTORNEY

**CLASS 35—(Continued).**

SN 85-100,064. MARTIN MARIETTA MATERIALS, INC., RALEIGH, NC. FILED 8-4-2010.

**REALTIME ROCKS**

THE MARK CONSISTS OF STANDARD CHARACTERS WITHOUT CLAIM TO ANY PARTICULAR FONT, STYLE, SIZE, OR COLOR.

NO CLAIM IS MADE TO THE EXCLUSIVE RIGHT TO USE "REALTIME", APART FROM THE MARK AS SHOWN.

FOR INFORMATION MANAGEMENT SERVICES, NAMELY, SHIPMENT PROCESSING, PREPARING SHIPPING DOCUMENTS, SALES RECEIPTS, AND INVOICES, TRACKING DOCUMENTS, PACKAGES, SALES RECEIPTS, CARGO, AND FREIGHT OVER COMPUTER NETWORKS, INTRANETS AND INTERNETS (U.S. CLS. 100, 101 AND 102).

KEVIN DINALLO, EXAMINING ATTORNEY

SN 85-101,868. THE BIG RED WAGON, LLC, POWELL, OH. FILED 8-6-2010.



NO CLAIM IS MADE TO THE EXCLUSIVE RIGHT TO USE "BABY", "KID", "TEEN" AND "MATERNITY", APART FROM THE MARK AS SHOWN.

THE MARK CONSISTS OF A CIRCLE CONTAINING THE WORDS "EVERYTHING UNDER ONE ROOF" SEPARATED BY A LINE FROM THE WORDS "BABY", "KID", "TEEN", "MATERNITY".

FOR PROVIDING EVENTS IN NON-RETAIL MARKET AND FAIR SETTINGS THAT BRING TOGETHER, FOR THE BENEFIT OF OTHERS, A VARIETY OF CONSIGNMENT GOODS AND SERVICES, THE GOODS FEATURING CHILDREN'S CLOTHING, TOYS, FURNITURE AND GEAR, AND MATERNITY CLOTHING AND GEAR, THE EVENTS ENABLING POTENTIAL PURCHASERS TO CONVENIENTLY VIEW AND PURCHASE SUCH GOODS AND SERVICES; CONSIGNMENT SERVICES, NAMELY, ARRANGING AND CONDUCTING EVENTS FEATURING GOODS RECEIVED ON CONSIGNMENT FROM OTHERS FOR PRESENTATION TO POTENTIAL PURCHASERS IN NON-RETAIL MARKET AND FAIR SETTINGS (U.S. CLS. 100, 101 AND 102).

FIRST USE 3-1-2010; IN COMMERCE 3-1-2010.

KATHERINE E. HALMEN, EXAMINING ATTORNEY

**CLASS 35—(Continued).**

SN 85-101,942. TEXZON FRANCHISE, RED OAK, TX. FILED 8-6-2010.



NO CLAIM IS MADE TO THE EXCLUSIVE RIGHT TO USE "UTILITIES", APART FROM THE MARK AS SHOWN. THE COLOR(S) DARK BLUE AND GOLD IS/ARE CLAIMED AS A FEATURE OF THE MARK.

THE MARK CONSISTS OF THE STYLIZED WORD "TEXZON" IN DARK BLUE LETTERS WITH A GOLD LIGHTNING BOLT IN THE MIDDLE FORMING PART OF THE "X" AND "Z", WITH THE STYLIZED WORD "UTILITIES" IN DARK BLUE LETTERS BELOW AND TO THE RIGHT OF "TEXZON". THE COLOR WHITE APPEARING IN THE MARK REPRESENTS BACKGROUND AND IS NOT PART OF THE MARK.

FOR UTILITY BILL MANAGEMENT SERVICES, NAMELY, TRACKING, REPORTING, ANALYZING AND DELIVERING ENERGY INFORMATION IN THE FORM OF UTILITY BILLS AND UTILITY METER DATA RATE SCHEDULES (U.S. CLS. 100, 101 AND 102). FIRST USE 6-0-2010; IN COMMERCE 8-0-2010.

ANDREW LEASER, EXAMINING ATTORNEY

SN 85-102,333. SOLEN GROUP LLC, MIAMI, FL. FILED 8-6-2010.



NO CLAIM IS MADE TO THE EXCLUSIVE RIGHT TO USE "SUSTAINABLE", APART FROM THE MARK AS SHOWN.

THE COLOR(S) GREEN IS/ARE CLAIMED AS A FEATURE OF THE MARK.

THE MARK CONSISTS OF A GREEN CIRCLE MADE WITH FOUR ELEMENTS SIMILAR TO A WAXING CRESCENT MOON ALONG WITH THE TWO WORDS "ONLY SUSTAINABLE" IN GREEN.

FOR ASSISTANCE AND CONSULTANCY SERVICES IN THE FIELD OF BUSINESS MANAGEMENT OF COMPANIES IN THE ENERGY SECTOR; BUSINESS VENTURE DEVELOPMENT AND FORMATION CONSULTING SERVICES FOR THE RENEWABLE ENERGY INDUSTRY; PROMOTING THE ENERGY EFFICIENT PRODUCTS AND SERVICES OF OTHERS (U.S. CLS. 100, 101 AND 102).

FIRST USE 5-1-2010; IN COMMERCE 7-10-2010. STEVEN JACKSON, EXAMINING ATTORNEY

**CLASS 35—(Continued).**

SN 85-105,908. KELLOGG NORTH AMERICA COMPANY, BATTLE CREEK, MI. FILED 8-12-2010.

**POP-TARTS VARIETIZER**

THE MARK CONSISTS OF STANDARD CHARACTERS WITHOUT CLAIM TO ANY PARTICULAR FONT, STYLE, SIZE, OR COLOR.

OWNER OF U.S. REG. NOS. 791,514, 1,671,971 AND 3,790,914.

FOR CUSTOMIZED VENDING MACHINE SERVICES; PROVIDING CUSTOMIZED VENDING MACHINE SERVICES FROM A UNIQUE DISPENSING APPARATUS (U.S. CLS. 100, 101 AND 102).

FIRST USE 8-9-2010; IN COMMERCE 8-9-2010.

MICHAEL GAFFAR, EXAMINING ATTORNEY

SN 85-105,930. KELLOGG NORTH AMERICA COMPANY, BATTLE CREEK, MI. FILED 8-12-2010.

**VARIETIZER**

THE MARK CONSISTS OF STANDARD CHARACTERS WITHOUT CLAIM TO ANY PARTICULAR FONT, STYLE, SIZE, OR COLOR.

OWNER OF U.S. REG. NOS. 552,435 AND 3,455,340.

FOR CUSTOMIZED VENDING MACHINE SERVICES; PROVIDING CUSTOMIZED VENDING MACHINE SERVICES FROM A UNIQUE DISPENSING APPARATUS (U.S. CLS. 100, 101 AND 102).

FIRST USE 8-9-2010; IN COMMERCE 8-9-2010.

MICHAEL GAFFAR, EXAMINING ATTORNEY

SN 85-105,977. VAJEN LLC, DBA JOCKO, LOS ANGELES, CA. FILED 8-12-2010.

**JOCKO**

THE MARK CONSISTS OF STANDARD CHARACTERS WITHOUT CLAIM TO ANY PARTICULAR FONT, STYLE, SIZE, OR COLOR.

FOR ON-LINE WHOLESALE AND RETAIL STORE SERVICES FEATURING MEN'S SWIMWEAR, UNDERWEAR AND KNITWEAR; WHOLESALE DISTRIBUTORSHIPS FEATURING MEN'S SWIMWEAR, UNDERWEAR AND KNITWEAR (U.S. CLS. 100, 101 AND 102).

FIRST USE 10-1-2000; IN COMMERCE 10-1-2000.

ALICE BENMAMAN, EXAMINING ATTORNEY

**CLASS 35—(Continued).**

SN 85-106,385. ATLANTIC INTERNATIONAL DISTRIBUTORS, INC., DBA ATLANTIC QUALITY PARTS, JACKSONVILLE, FL. FILED 8-12-2010.



THE MARK CONSISTS OF A STYLIZED GEOMETRIC CHAIN CONSISTING OF TWO SQUARES, ONE APPEARING ABOVE AND TO THE LEFT AND CONNECTED TO THE OTHER SQUARE WITH A RECTANGULAR LINK.

FOR WHOLESALE DISTRIBUTORSHIPS FEATURING TRACTOR PARTS AND EQUIPMENT (U.S. CLS. 100, 101 AND 102).

FIRST USE 2-18-2009; IN COMMERCE 2-18-2009.  
PAULA MAHONEY, EXAMINING ATTORNEY

SN 85-108,143. JUSTIN NORRIS PROFESSIONAL CORPORATION, CALGARY, ALBERTA, CANADA, FILED 8-16-2010.

**PLANET CONTACTS**

THE MARK CONSISTS OF STANDARD CHARACTERS WITHOUT CLAIM TO ANY PARTICULAR FONT, STYLE, SIZE, OR COLOR.

PRIORITY CLAIMED UNDER SEC. 44(D) ON CANADA APPLICATION NO. 1470201, FILED 2-19-2010, REG. NO. 786183, DATED 12-30-2010, EXPIRES 12-30-2025.

NO CLAIM IS MADE TO THE EXCLUSIVE RIGHT TO USE "CONTACTS", APART FROM THE MARK AS SHOWN.

FOR ON-LINE RETAIL STORE SERVICES FEATURING LENSES; ON-LINE RETAIL STORE SERVICES FEATURING CONTACT LENSES, CONTACT LENS PRODUCTS AND EYEGASSES (U.S. CLS. 100, 101 AND 102).

JAMES LOVELACE, EXAMINING ATTORNEY

**CLASS 35—(Continued).**

SN 85-108,581. MRSPUDZ FRESH CUT FRIES LLC, FRANKTOWN, CO. FILED 8-16-2010.



NO CLAIM IS MADE TO THE EXCLUSIVE RIGHT TO USE "FRESH CUT" AND "FRESH CUT FRIES", APART FROM THE MARK AS SHOWN.

THE MARK CONSISTS OF A STYLIZED POTATO-SHAPED FIGURINE HOLDING A CUP OF FRIES WITH THE WORDING "FRESH CUT" THEREON IN ONE HAND AND A CYCLONE POTATO DESIGN IN THE OTHER HAND. ABOVE THE DESIGN IS THE WORDING "MR. SPUDS" IN STYLIZED LETTERING AND BENEATH THE DESIGN IS THE WORDING "FRESH CUT FRIES" IN STYLIZED LETTERING.

FOR MOBILE CONCESSION STANDS FEATURING FOOD (U.S. CLS. 100, 101 AND 102).

FIRST USE 7-7-2010; IN COMMERCE 7-12-2010.  
KATHERINE STOIDES, EXAMINING ATTORNEY

SN 85-109,677. DOWNHOLE DYNAMICS LLC, OWASSO, OK. FILED 8-17-2010.



NO CLAIM IS MADE TO THE EXCLUSIVE RIGHT TO USE "DOWNHOLE" AND "LLC", APART FROM THE MARK AS SHOWN.

THE MARK CONSISTS OF THE WORD "DOWNHOLE" WITH THE ADDITIONAL WORDS "DYNAMICS LLC" LOCATED BELOW AND TO THE RIGHT AND HAVING FOUR (4) CONCENTRIC RINGS EACH ONE ELEVATED AND SLIGHTLY SMALLER THAN THE PREVIOUS LOCATED TO THE RIGHT AND SLIGHTLY ABOVE THE WORD "DOWNHOLE".

FOR BUSINESS CONSULTING FOR THE OIL AND GAS INDUSTRY (U.S. CLS. 100, 101 AND 102).

FIRST USE 3-12-2010; IN COMMERCE 3-12-2010.  
MICHAEL WEBSTER, EXAMINING ATTORNEY

**CLASS 35—(Continued).**

SN 85-111,012. HUMANGRID GMBH, DORTMUND, FED REP GERMANY, FILED 8-19-2010.



PRIORITY CLAIMED UNDER SEC. 44(D) ON ERPN CMNTY TM OFC APPLICATION NO. 008902603, FILED 2-23-2010.

THE MARK CONSISTS OF SILHOUETTES OF TEN HUMAN FIGURES OF VARYING GENDER AND SIZE OVER THE WORD "CLICKWORKER.COM".

FOR ARRANGING OF CONTRACTUAL SERVICES WITH THIRD PARTIES; BUSINESS MANAGEMENT AND CONSULTATION; EMPLOYMENT AGENCIES; EMPLOYMENT HIRING, RECRUITING, PLACEMENT, STAFFING AND CAREER NETWORKING SERVICES; INFORMATION, ADVISORY AND CONSULTANCY SERVICES RELATING TO BUSINESS AND MANAGEMENT OR BUSINESS ADMINISTRATION, INCLUDING SUCH SERVICES PROVIDED ONLINE OR VIA THE INTERNET; PERSONNEL PLACEMENT AND RECRUITMENT; ADVERTISING AGENCIES, NAMELY, PROMOTING THE GOODS AND SERVICES OF OTHERS; ADVERTISING AND PROMOTION SERVICES AND RELATED CONSULTING; ADVERTISING VIA ELECTRONIC MEDIA AND SPECIFICALLY THE INTERNET (U.S. CLS. 100, 101 AND 102).

FIRST USE 3-4-2010; IN COMMERCE 3-4-2010.  
LINDA ESTRADA, EXAMINING ATTORNEY

**CLASS 35—(Continued).**

SN 85-111,548. WISCONSIN MILK MARKETING BOARD, INC., MADISON, WI. FILED 8-19-2010.

**GRILLED CHEESE ACADEMY**

NO CLAIM IS MADE TO THE EXCLUSIVE RIGHT TO USE "CHEESE", APART FROM THE MARK AS SHOWN.

THE MARK CONSISTS OF THE WORDS "GRILLED CHEESE ACADEMY" IN STYLIZED FONT. THE MARK ALSO INCLUDES AN ARBITRARY SYMBOL RESEMBLING TWO CROSSED V'S. THIS SYMBOL HAS NO MEANING OTHER THAN TO COMPLETE THE LOGO.

FOR PROMOTING THE SALE OF GOODS OF OTHERS, NAMELY, CHEESE, THROUGH THE DISTRIBUTION OF INFORMATION VIA PRINTED AND WEBSITE MATERIALS AND BROCHURES (U.S. CLS. 100, 101 AND 102).

FIRST USE 4-1-2010; IN COMMERCE 4-1-2010.  
C. DIONNE CLYBURN, EXAMINING ATTORNEY

SN 85-111,816. CIVILIZED WORLD, INC., SAN JOSE, CA. FILED 8-19-2010.

SN 85-111,095. WAREHOUSECLUB.COM, L.L.C., TEANECK, NJ. FILED 8-19-2010.



NO CLAIM IS MADE TO THE EXCLUSIVE RIGHT TO USE "WAREHOUSE CLUB.COM", APART FROM THE MARK AS SHOWN.

THE COLOR(S) BLUE AND WHITE IS/ARE CLAIMED AS A FEATURE OF THE MARK.

THE MARK CONSISTS OF A STYLIZED SHOPPING CART DESIGN AND THE WORDING "WAREHOUSECLUB.COM SHOP LIKE A MANHATTANITE, SAVE LIKE A SUBURBANITE.". THE BASKET PORTION OF THE SHOPPING CART CONTAINS THE "W" IN THE WORD "WAREHOUSECLUB.COM". THE LETTER "W" APPEARS IN WHITE, AND THE SHOPPING CART AND REMAINING LETTERS ALL APPEAR IN THE COLOR BLUE.

FOR ON-LINE RETAIL STORE SERVICES FEATURING HOUSEHOLD GOODS AND GROCERIES (U.S. CLS. 100, 101 AND 102).

FIRST USE 1-0-2009; IN COMMERCE 1-0-2009.  
DAVID ELTON, EXAMINING ATTORNEY

**Willow Glen Music**

THE MARK CONSISTS OF STANDARD CHARACTERS WITHOUT CLAIM TO ANY PARTICULAR FONT, STYLE, SIZE, OR COLOR.

NO CLAIM IS MADE TO THE EXCLUSIVE RIGHT TO USE "MUSIC", APART FROM THE MARK AS SHOWN.

FOR ON-LINE RETAIL STORE SERVICES FEATURING GUITARS, AMPLIFIERS, KEYBOARDS, PERCUSSION, PRO-AUDIO, DRUMS, SHEET MUSIC, MUSIC BOOKS AND ACCESSORIES AND PRODUCTS RELATED THERETO; RETAIL STORE SERVICES FEATURING GUITARS, AMPLIFIERS, KEYBOARDS, PERCUSSION, PRO-AUDIO, DRUMS, SHEET MUSIC, MUSIC BOOKS AND ACCESSORIES AND PRODUCTS RELATED THERETO; MAIL ORDER CATALOG SERVICES FEATURING GUITARS, AMPLIFIERS, KEYBOARDS, PERCUSSION, PRO-AUDIO, DRUMS, SHEET MUSIC, MUSIC BOOKS AND ACCESSORIES AND PRODUCTS RELATED THERETO (U.S. CLS. 100, 101 AND 102).

LESLEY LAMOTHE, EXAMINING ATTORNEY

**CLASS 35—(Continued).**

SN 85-111,827. CIVILIZED WORLD, INC., CAMPBELL, CA. FILED 8-19-2010.

## Santa Cruz Music

THE MARK CONSISTS OF STANDARD CHARACTERS WITHOUT CLAIM TO ANY PARTICULAR FONT, STYLE, SIZE, OR COLOR.

NO CLAIM IS MADE TO THE EXCLUSIVE RIGHT TO USE "MUSIC", APART FROM THE MARK AS SHOWN.

FOR ON-LINE RETAIL STORE SERVICES FEATURING GUITARS, AMPLIFIERS, KEYBOARDS, PERCUSSION, PRO-AUDIO, DRUMS, SHEET MUSIC, MUSIC BOOKS AND ACCESSORIES AND PRODUCTS RELATED THERETO; RETAIL STORE SERVICES FEATURING GUITARS, AMPLIFIERS, KEYBOARDS, PERCUSSION, PRO-AUDIO, DRUMS, SHEET MUSIC, MUSIC BOOKS AND ACCESSORIES AND PRODUCTS RELATED THERETO; MAIL ORDER CATALOG SERVICES FEATURING GUITARS, AMPLIFIERS, KEYBOARDS, PERCUSSION, PRO-AUDIO, DRUMS, SHEET MUSIC, MUSIC BOOKS AND ACCESSORIES AND PRODUCTS RELATED THERETO (U.S. CLS. 100, 101 AND 102).

LESLEY LAMOTHE, EXAMINING ATTORNEY

**CLASS 35—(Continued).**

SN 85-113,521. INJURED WORKERS PHARMACY, LLC, METHUEN, MA. FILED 8-23-2010.

## IWP A PATIENT ADVOCATE PHARMACY

THE MARK CONSISTS OF STANDARD CHARACTERS WITHOUT CLAIM TO ANY PARTICULAR FONT, STYLE, SIZE, OR COLOR.

NO CLAIM IS MADE TO THE EXCLUSIVE RIGHT TO USE "A PATIENT ADVOCATE PHARMACY", APART FROM THE MARK AS SHOWN.

FOR MAIL ORDER PHARMACY SERVICES; RETAIL PHARMACY SERVICES (U.S. CLS. 100, 101 AND 102).

FIRST USE 10-21-2008; IN COMMERCE 10-21-2008.

ALEX KEAM, EXAMINING ATTORNEY

SN 85-114,215. COMMERCIAL TRAFFIC COMPANY, PARMA, OH. FILED 8-24-2010.

SN 85-113,194. GRUBHUB, INC., CHICAGO, IL. FILED 8-23-2010.



**grubHub.com**  
eating made easy

THE COLOR(S) RED AND LIGHT RED IS/ARE CLAIMED AS A FEATURE OF THE MARK.

THE MARK CONSISTS OF THE STYLIZED WORD "GRUBHUB.COM" IN RED ABOVE THE STYLIZED WORDS "EATING MADE EASY" IN LIGHT RED.

FOR ON-LINE ADVERTISING AND MARKETING SERVICES (U.S. CLS. 100, 101 AND 102).

FIRST USE 8-15-2010; IN COMMERCE 8-15-2010.

ELLEN PERKINS, EXAMINING ATTORNEY

## RatePort

THE MARK CONSISTS OF STANDARD CHARACTERS WITHOUT CLAIM TO ANY PARTICULAR FONT, STYLE, SIZE, OR COLOR.

FOR INFORMATION MANAGEMENT SERVICES, NAMELY, SHIPMENT PROCESSING, PREPARING SHIPPING DOCUMENTS AND INVOICES, TRACKING DOCUMENTS, PACKAGES AND FREIGHT OVER COMPUTER NETWORKS, INTRANETS AND INTERNETS (U.S. CLS. 100, 101 AND 102).

FIRST USE 7-20-2010; IN COMMERCE 7-20-2010.

BENJAMIN OKEKE, EXAMINING ATTORNEY



**CLASS 35—(Continued).**

SN 85-114,407. GROWTH MANAGEMENT CENTER, TRUCKEE, CA. FILED 8-24-2010.



**Opportunity  
Knocks Twice**

THE MARK CONSISTS OF A BLACK RECTANGULAR-SHAPED BOX, WITH TWO ROUNDED CORNERS AND TWO ANGULAR CORNERS, CONTAINING "OK2X" IN WHITE FONT, AND HAVING THE PHRASE "OPPORTUNITY KNOCKS TWICE" BELOW THE BLACK RECTANGULAR-SHAPED BOX.

FOR BUSINESS CONSULTATION AND MANAGEMENT REGARDING MARKETING ACTIVITIES AND LAUNCHING OF NEW PRODUCTS; BUSINESS CONSULTATION SERVICES; BUSINESS MANAGEMENT CONSULTATION (U.S. CLS. 100, 101 AND 102).

FIRST USE 11-30-2006; IN COMMERCE 7-9-2007.  
NELSON SNYDER, EXAMINING ATTORNEY

---

SN 85-114,723. EASTON, MARGO, GENEVA, IL. FILED 8-24-2010.

**The Cranky Housewife**

THE MARK CONSISTS OF STANDARD CHARACTERS WITHOUT CLAIM TO ANY PARTICULAR FONT, STYLE, SIZE, OR COLOR.

FOR PROVIDING A WEBSITE FEATURING INFORMATION ABOUT POLITICAL OPINIONS AND ISSUES (U.S. CLS. 100, 101 AND 102).

COURTNEY ALVAREZ, EXAMINING ATTORNEY

---

SN 85-116,815. CAREER COLLEGE ASSOCIATION, WASHINGTON, DC. FILED 8-26-2010.

**APSCU**

THE MARK CONSISTS OF STANDARD CHARACTERS WITHOUT CLAIM TO ANY PARTICULAR FONT, STYLE, SIZE, OR COLOR.

FOR ASSOCIATION SERVICES, NAMELY, PROMOTING THE INTERESTS OF PRIVATE SECTOR, POSTSECONDARY SCHOOLS, INSTITUTES, COLLEGES, AND UNIVERSITIES (U.S. CLS. 100, 101 AND 102).

FIRST USE 9-22-2010; IN COMMERCE 9-22-2010.  
RUSS HERMAN, EXAMINING ATTORNEY

**CLASS 35—(Continued).**

SN 85-117,183. CAREER COLLEGE ASSOCIATION, WASHINGTON, DC. FILED 8-27-2010.



THE MARK CONSISTS OF A MISCELLANEOUS DESIGN. FOR ASSOCIATION SERVICES, NAMELY, PROMOTING THE INTERESTS OF PRIVATE SECTOR, POSTSECONDARY SCHOOLS, INSTITUTES, COLLEGES, AND UNIVERSITIES (U.S. CLS. 100, 101 AND 102).

FIRST USE 9-22-2010; IN COMMERCE 9-22-2010.  
RUSS HERMAN, EXAMINING ATTORNEY

---

SN 85-117,351. AMERICAN CUSTOMER CARE, INC., BRISTOL, CT. FILED 8-27-2010.

**AMERICAN CUSTOMER CARE**

THE MARK CONSISTS OF STANDARD CHARACTERS WITHOUT CLAIM TO ANY PARTICULAR FONT, STYLE, SIZE, OR COLOR.

NO CLAIM IS MADE TO THE EXCLUSIVE RIGHT TO USE "CUSTOMER CARE", APART FROM THE MARK AS SHOWN.

SEC. 2(F).

FOR MANAGEMENT OF TELEPHONE CALL CENTERS FOR OTHERS; OPERATION OF TELEPHONE CALL CENTERS FOR OTHERS (U.S. CLS. 100, 101 AND 102).

FIRST USE 10-2-2000; IN COMMERCE 10-2-2000.  
MARTHA FROMM, EXAMINING ATTORNEY

**CLASS 35—(Continued).**

SN 85-117,697. INCAVIS INC., ROCKVILLE, MD. FILED 8-27-2010.

grodo

THE MARK CONSISTS OF STANDARD CHARACTERS WITHOUT CLAIM TO ANY PARTICULAR FONT, STYLE, SIZE, OR COLOR.

FOR ADMINISTRATION OF A CONSUMER REWARDS PROGRAM TO PROMOTE SPECIFIC SPENDING BEHAVIORS AT SPECIFIC MERCHANTS (U.S. CLS. 100, 101 AND 102).

ALEXANDER L. POWERS, EXAMINING ATTORNEY

SN 85-117,967. ECOTALITY, INC., TEMPE, AZ. FILED 8-27-2010.

EV MICRO-CLIMATE

THE MARK CONSISTS OF STANDARD CHARACTERS WITHOUT CLAIM TO ANY PARTICULAR FONT, STYLE, SIZE, OR COLOR.

NO CLAIM IS MADE TO THE EXCLUSIVE RIGHT TO USE "EV", APART FROM THE MARK AS SHOWN.

FOR BUSINESS DEVELOPMENT, BUSINESS PLANNING RESEARCH AND BUSINESS CONSULTING SERVICES IN THE FIELD OF COMMUNITY PLANNING FOR THE DEPLOYMENT OF ELECTRIC TRANSPORTATION; BUSINESS DEVELOPMENT AND BUSINESS PLANNING CONSULTING SERVICES FOR COMMUNITIES, NAMELY, ASSISTING GOVERNMENT ORGANIZATIONS, UTILITIES, PRIVATE-SECTOR BUSINESSES, AND AUTOMOTIVE MANUFACTURERS IN THE PLANNING FOR THE DEPLOYMENT OF A PUBLIC ELECTRIC TRANSPORTATION CHARGING INFRASTRUCTURE (U.S. CLS. 100, 101 AND 102).

FIRST USE 1-8-2009; IN COMMERCE 1-8-2009.

MICHELE SWAIN, EXAMINING ATTORNEY

SN 85-120,001. MISSOURI BASIN MUNICIPAL POWER AGENCY, DBA MISSOURI RIVER ENERGY SERVICES, SIOUX FALLS, SD. FILED 8-31-2010.

GET THE LOAD DOWN

THE MARK CONSISTS OF STANDARD CHARACTERS WITHOUT CLAIM TO ANY PARTICULAR FONT, STYLE, SIZE, OR COLOR.

FOR CONSULTATION IN THE FIELD OF ENERGY EFFICIENCY, ENERGY CONSUMPTION, AND ENERGY USAGE MANAGEMENT; AND PROVIDING INFORMATION TO CONSUMERS IN THE FIELDS OF ENERGY USAGE MANAGEMENT, ENERGY SAVINGS AND EFFICIENCY (U.S. CLS. 100, 101 AND 102).

DOMINIC J. FERRAIUOLO, EXAMINING ATTORNEY

**CLASS 35—(Continued).**

SN 85-120,179. DIKEN INTERNATIONAL, RICHLAND HILLS, TX. FILED 8-31-2010.

DIKEN

THE MARK CONSISTS OF STANDARD CHARACTERS WITHOUT CLAIM TO ANY PARTICULAR FONT, STYLE, SIZE, OR COLOR.

FOR CATALOG ORDERING SERVICE FEATURING PROTECTIVE CLOTHING, NAMELY, BOOTS, INSULATED CLOTHING, HOODS, GLOVES, APRONS, SLEEVES, AND GOWNS, CAPS AND HAIRNETS, AND RAIN WEAR; JANITORIAL AND SANITATION PRODUCTS, NAMELY, MOPS AND MITTS, BRUSHES, SQUEEGEES, BROOMS, DUSTPANS, SCRAPERS, MOP HANDLES AND MOP BUCKETS, PADS AND WIPES, WATER MIXING STATIONS, CABINETS, NOZZLES, ADAPTERS, HOSES, SPRAYERS, WALL MOUNT SINKS AND WALL MOUNT LAVATORIES, SINK REPLACEMENT PARTS, HAND DRYERS; MATERIAL HANDLING PRODUCTS, NAMELY, TOTE BAGS, CARTS AND DOLLIES, FOOD BOXES, CARTS, BINS, TUBS, TRUCKS AND BUGGIES, CUTTING BOARDS AND FREEZER SPACERS, SPATULAS, PADDLES, FOOD HOES, SHOVELS AND FORKS, BRUTE DRUMS, ROLL-OUT CONTAINERS, TRASH CONTAINERS, BUCKETS AND CONTAINER OPENERS, WORK CARTS AND STORAGE CABINETS, DRUM PUMPS; SAFETY PROTECTION PRODUCTS, NAMELY, HARNESSES AND LANYARDS, SHOWER HEADS, EYE PROTECTION, EAR PROTECTION, RESPIRATORS, HEAD PROTECTION, BACK SUPPORTS, AND CUT PROTECTION GLOVES, SLEEVES, AND APRONS; CUTLERY, NAMELY, KNIVES, SHARPENERS, AND SCABBARDS; THERMOMETERS; TIMERS; AND OTHER PROCESSING EQUIPMENT, NAMELY, STUNNERS, BEEF TROLLEYS, HOG SHACKLES, TROLLEYS AND TROLLEY PARTS, MEAT TREES, SMOKEHOUSE TRUCKS, FOOD GRADE GREASES, BAND SAW BLADES, BONING HOOKS, AND MEAT MARKING CRAYONS; ALL FOR USE IN THE FOOD, DAIRY, MEAT, POULTRY, PORK PROCESSING INDUSTRIES, THE MEAT AND FOOD PACKAGING INDUSTRIES AND THE MANUFACTURING INDUSTRY (U.S. CLS. 100, 101 AND 102).

FIRST USE 5-1-2008; IN COMMERCE 5-1-2008.

JEFF DEFORD, EXAMINING ATTORNEY

SN 85-122,055. KING, BRIAN M., SPRINGFIELD, MO. FILED 9-2-2010.

TITAN NUTRITION

THE MARK CONSISTS OF STANDARD CHARACTERS WITHOUT CLAIM TO ANY PARTICULAR FONT, STYLE, SIZE, OR COLOR.

NO CLAIM IS MADE TO THE EXCLUSIVE RIGHT TO USE "NUTRITION", APART FROM THE MARK AS SHOWN.

FOR ON-LINE WHOLESALE AND RETAIL STORE SERVICES FEATURING DIETARY SUPPLEMENTS (U.S. CLS. 100, 101 AND 102).

FIRST USE 1-31-2009; IN COMMERCE 1-31-2009.

WILLIAM BRECKENFELD, EXAMINING ATTORNEY

**CLASS 35—(Continued).**

SN 85-125,669. TODD BECKMAN, DBA TY ALEXANDER'S, LAWRENCEBURG, TN. FILED 9-9-2010.

TY ALEXANDER'S

THE MARK CONSISTS OF STANDARD CHARACTERS WITHOUT CLAIM TO ANY PARTICULAR FONT, STYLE, SIZE, OR COLOR.

THE NAME(S), PORTRAIT(S), AND/OR SIGNATURE(S) SHOWN IN THE MARK IDENTIFIES "TY ALEXANDER", WHOSE CONSENT(S) TO REGISTER IS MADE OF RECORD.

FOR RETAIL FURNITURE STORES (U.S. CLS. 100, 101 AND 102).

FIRST USE 9-1-2001; IN COMMERCE 9-1-2001.  
PAM WILLIS, EXAMINING ATTORNEY

**CLASS 35—(Continued).**

SN 85-127,008. CREATIVE DISTINCTIONS, LLC, MIAMI, FL. FILED 9-10-2010.



NO CLAIM IS MADE TO THE EXCLUSIVE RIGHT TO USE "BOSTON", APART FROM THE MARK AS SHOWN.

THE MARK CONSISTS OF A HEART SHAPE DESIGN LOCATED ABOVE THE STYLIZED WORD "BOSTON", BOTH SET AGAINST A CIRCULAR BACKGROUND.

FOR RETAIL STORE SERVICES LOCATED IN AIRPORTS FEATURING CLOTHING, SOUVENIRS AND PLUSH TOYS (U.S. CLS. 100, 101 AND 102).

FIRST USE 4-13-2010; IN COMMERCE 4-13-2010.  
TINA L. SNAPP, EXAMINING ATTORNEY

SN 85-126,401. A9.COM, INC., PALO ALTO, CA. FILED 9-9-2010.

CLICKDRIVER

THE MARK CONSISTS OF STANDARD CHARACTERS WITHOUT CLAIM TO ANY PARTICULAR FONT, STYLE, SIZE, OR COLOR.

OWNER OF U.S. REG. NO. 2,881,557.  
FOR ADVERTISING SERVICES; BUSINESS MANAGEMENT; BUSINESS ADMINISTRATION; OFFICE FUNCTIONS; ONLINE BUSINESS MARKETING INFORMATION SERVICES AND PUBLIC RELATIONS (U.S. CLS. 100, 101 AND 102).

MARTHA FROMM, EXAMINING ATTORNEY

SN 85-127,024. CREATIVE DISTINCTIONS, LLC, MIAMI, FL. FILED 9-10-2010.



NO CLAIM IS MADE TO THE EXCLUSIVE RIGHT TO USE "MIAMI", APART FROM THE MARK AS SHOWN.

THE MARK CONSISTS OF A HEART SHAPE DESIGN LOCATED ABOVE THE STYLIZED WORD "MIAMI", BOTH SET AGAINST A CIRCULAR BACKGROUND.

FOR RETAIL STORE SERVICES LOCATED IN AIRPORTS FEATURING CLOTHING, SOUVENIRS AND PLUSH TOYS (U.S. CLS. 100, 101 AND 102).

TINA L. SNAPP, EXAMINING ATTORNEY

**CLASS 35—(Continued).**

SN 85-127,107. PEOPLE SYNC INCORPORATED, ADDISON, TX. FILED 9-10-2010.

**peoplesync.com**

THE MARK CONSISTS OF STANDARD CHARACTERS WITHOUT CLAIM TO ANY PARTICULAR FONT, STYLE, SIZE, OR COLOR.

FOR EMPLOYMENT HIRING, RECRUITING, PLACEMENT, STAFFING AND CAREER NETWORKING SERVICES; EMPLOYMENT RECRUITING AND STAFFING SERVICES PROVIDED VIA TEXT MESSAGING; EMPLOYMENT RECRUITING CONSULTATION; EMPLOYMENT SERVICES, NAMELY, PROVIDING A WEB SITE WITH ONLINE VIDEO, AUDIO AND TEXTUAL INTERVIEWING APPLICATIONS TO SUPPORT RECRUITING, ADMISSIONS, AND GENERAL CANDIDATE SCREENING PROCESSES; EMPLOYMENT STAFFING CONSULTATION SERVICES; PERSONALITY TESTING FOR BUSINESS PURPOSES; PERSONNEL SELECTION USING PSYCHOLOGICAL TESTING; PSYCHOLOGICAL TESTING FOR THE SELECTION OF PERSONNEL; TESTING TO DETERMINE EMPLOYMENT SKILLS; TESTING TO DETERMINE JOB COMPETENCY; TESTING TO DETERMINE PROFESSIONAL COMPETENCY; TESTING, ANALYSIS AND EVALUATION OF THE BROAD KNOWLEDGE, EXPERIENCE AND PROFESSIONAL JUDGMENT OF PUBLIC RELATIONS PROFESSIONALS FOR PURPOSES OF CAREER ENHANCEMENT AND ADVANCEMENT IN THE FIELD OF PUBLIC RELATIONS (U.S. CLS. 100, 101 AND 102).

FIRST USE 11-8-2010; IN COMMERCE 11-8-2010.  
TIMOTHY FINNEGAN, EXAMINING ATTORNEY

SN 85-127,943. THE COMMERCIAL TRAFFIC COMPANY, PARMA, OH. FILED 9-13-2010.

**CTrak**

THE MARK CONSISTS OF THE WORDING "CTRACK" IN A STYLIZED FONT.

FOR INFORMATION MANAGEMENT SERVICES, NAMELY, SHIPMENT PROCESSING, PREPARING SHIPPING DOCUMENTS AND INVOICES, TRACKING DOCUMENTS, PACKAGES AND FREIGHT OVER COMPUTER NETWORKS, INTRANETS AND INTERNETS (U.S. CLS. 100, 101 AND 102).

FIRST USE 6-10-2010; IN COMMERCE 6-10-2010.  
RENEE MCCRAY, EXAMINING ATTORNEY

**CLASS 35—(Continued).**

SN 85-129,063. INTERNATIONAL EXHIBITIONS, INC., HOUSTON, TX. FILED 9-14-2010.

**VACATION, LEISURE &  
OUTDOOR SHOW**

THE MARK CONSISTS OF STANDARD CHARACTERS WITHOUT CLAIM TO ANY PARTICULAR FONT, STYLE, SIZE, OR COLOR.

OWNER OF U.S. REG. NO. 2,434,739.

NO CLAIM IS MADE TO THE EXCLUSIVE RIGHT TO USE "SHOW", APART FROM THE MARK AS SHOWN.

SEC. 2(F).

FOR PROMOTING AND CONDUCTING TRADE SHOWS AND TRADE SHOW EXHIBITIONS IN THE FIELD OF SPORTS VACATIONS, LEISURE SPORTS AND OUTDOOR SPORTS (U.S. CLS. 100, 101 AND 102).

FIRST USE 0-0-1992; IN COMMERCE 0-0-1992.  
KATHERINE STOIDES, EXAMINING ATTORNEY

SN 85-129,141. SCREAMING EAGLE LLC, LEESBURG, VA. AND RED EAGLE LLC, LEESBURG, VA. FILED 9-14-2010.

**ACADEMY OF ETHICAL BROKERS  
& AGENTS**

THE MARK CONSISTS OF STANDARD CHARACTERS WITHOUT CLAIM TO ANY PARTICULAR FONT, STYLE, SIZE, OR COLOR.

NO CLAIM IS MADE TO THE EXCLUSIVE RIGHT TO USE "ETHICAL BROKERS & AGENTS", APART FROM THE MARK AS SHOWN.

FOR MATCHING CONSUMERS WITH REAL ESTATE PROFESSIONALS IN THE FIELD OF REAL ESTATE SERVICES VIA COMPUTER NETWORK; REAL ESTATE ADVERTISING SERVICES (U.S. CLS. 100, 101 AND 102).

FIRST USE 12-1-2008; IN COMMERCE 12-1-2008.  
JEFFERY COWARD, EXAMINING ATTORNEY

SN 85-130,224. TOM'S OUTDOOR FURNITURE, L.L.C., FORMERLY TOM HAID, REDWOOD CITY, CA. FILED 9-15-2010.

**Tom's Outdoor Furniture**

THE MARK CONSISTS OF STANDARD CHARACTERS WITHOUT CLAIM TO ANY PARTICULAR FONT, STYLE, SIZE, OR COLOR.

NO CLAIM IS MADE TO THE EXCLUSIVE RIGHT TO USE "OUTDOOR FURNITURE", APART FROM THE MARK AS SHOWN.

THE NAME(S), PORTRAIT(S), AND/OR SIGNATURE(S) SHOWN IN THE MARK IDENTIFIES "TOM HAID", WHOSE CONSENT(S) TO REGISTER IS MADE OF RECORD.

FOR RETAIL FURNITURE STORES (U.S. CLS. 100, 101 AND 102).

FIRST USE 12-31-1999; IN COMMERCE 12-31-1999.  
JULIE VEPPUMTHARA, EXAMINING ATTORNEY

**CLASS 35—(Continued).**

SN 85-132,446. DOG SNIFFER LLC, LOS ANGELES, CA. FILED 9-17-2010.

**Sniff It • Dig It • Review It**

THE COLOR(S) BLACK AND RED IS/ARE CLAIMED AS A FEATURE OF THE MARK.

THE MARK CONSISTS OF THE STYLIZED WORDS "SNIFF IT" IN BLACK FOLLOWED BY A RED DOT FOLLOWED BY THE STYLIZED WORDS "DIG IT" IN BLACK FOLLOWED BY A RED DOT, FOLLOWED BY THE STYLIZED WORDS "REVIEW IT" IN BLACK.

FOR PROMOTING THE GOODS AND SERVICES OF OTHERS IN THE FIELD OF DOGS BY PROVIDING A WEB PAGE FEATURING HYPER-LINKS TO THE WEBSITES OF OTHERS; PROMOTING THE DOG RELATED GOODS AND SERVICES OF OTHERS VIA A GLOBAL COMPUTER NETWORK; PROVIDING A WEB SITE FEATURING PRODUCT RATINGS AND REVIEWS OF THE CONSUMER GOODS AND SERVICES OF OTHERS IN THE FIELD OF DOGS; RENTAL OF ADVERTISING SPACE ON A WEBSITE (U.S. CLS. 100, 101 AND 102).

MICHAEL TANNER, EXAMINING ATTORNEY

SN 85-133,311. HOWARD CAPITAL MANAGEMENT, INC., ROSWELL, GA. FILED 9-20-2010.

**HCM PROFIT PUSH**

THE MARK CONSISTS OF STANDARD CHARACTERS WITHOUT CLAIM TO ANY PARTICULAR FONT, STYLE, SIZE, OR COLOR.

OWNER OF U.S. REG. NOS. 3,756,752 AND 3,774,085. FOR ANALYZING AND COMPILING DATA FOR MEASURING THE PERFORMANCE OF FINANCIAL MARKETS (U.S. CLS. 100, 101 AND 102).

FIRST USE 2-1-2010; IN COMMERCE 2-1-2010.

KAREN BRACEY, EXAMINING ATTORNEY

SN 85-134,040. UV PARTNERS, INC., SALT LAKE CITY, UT. FILED 9-20-2010.

**PELION VENTURE PARTNERS**

THE MARK CONSISTS OF STANDARD CHARACTERS WITHOUT CLAIM TO ANY PARTICULAR FONT, STYLE, SIZE, OR COLOR.

NO CLAIM IS MADE TO THE EXCLUSIVE RIGHT TO USE "VENTURE PARTNERS", APART FROM THE MARK AS SHOWN.

FOR STRATEGIC ADVISORY SERVICES RELATING TO BUSINESS MANAGEMENT AND BUSINESS OPERATIONS (U.S. CLS. 100, 101 AND 102).

FIRST USE 4-8-2010; IN COMMERCE 4-8-2010.

JUDITH HELFMAN, EXAMINING ATTORNEY

**CLASS 35—(Continued).**

SN 85-134,773. BROWN EYED BAKER, LLC, CHESWICK, PA. FILED 9-21-2010.



THE COLOR(S) BROWN AND PINK IS/ARE CLAIMED AS A FEATURE OF THE MARK.

THE MARK CONSISTS OF THE STYLIZED WORDING "BROWNEYEDBAKER", WITH "BROWN" AND "BAKER" IN THE COLOR BROWN, AND "EYED" IN THE COLOR PINK, OVER A BROWN LINE, AND BELOW THE BROWN LINE THE STYLIZED BROWN WORDING "SWEET · SAVORY · SINFUL", WITH A SHADED BROWN CIRCLE BETWEEN EACH TERM. THE COLOR WHITE REPRESENTS BACKGROUND, AND/OR TRANSPARENT AREAS AND IS NOT PART OF THE MARK.

FOR PROVIDING A WEBSITE FEATURING INFORMATION FOR CONSUMERS IN THE FIELD OF FOOD AND DRINKS, COOKING AND BAKING; PROMOTING THE GOODS AND SERVICES OF OTHERS BY PROVIDING A WEBSITE FEATURING LINKS TO THE RETAIL WEBSITES OF OTHERS IN THE FIELD OF FOOD AND DRINKS, COOKING AND BAKING (U.S. CLS. 100, 101 AND 102).

FIRST USE 1-1-2007; IN COMMERCE 1-1-2007.

ODESSA BIBBINS, EXAMINING ATTORNEY

SN 85-136,188. MCCHRYSTAL ASSOCIATES LLC, ALEXANDRIA, VA. FILED 9-23-2010.

**Plywood Leadership**

THE MARK CONSISTS OF STANDARD CHARACTERS WITHOUT CLAIM TO ANY PARTICULAR FONT, STYLE, SIZE, OR COLOR.

NO CLAIM IS MADE TO THE EXCLUSIVE RIGHT TO USE "LEADERSHIP", APART FROM THE MARK AS SHOWN.

FOR BUSINESS CONSULTATION IN THE FIELD OF BUSINESS LEADERSHIP DEVELOPMENT; BUSINESS MANAGEMENT CONSULTATION IN THE FIELD OF EXECUTIVE AND LEADERSHIP DEVELOPMENT; CONSULTING SERVICES IN BUSINESS LEADERSHIP DEVELOPMENT AND BUSINESS MANAGEMENT; PROMOTING PUBLIC INTEREST IN EDUCATION, RECOGNITION, CAREER ADVANCEMENT, AND LEADERSHIP FOR ELITE MANAGERS AND EXECUTIVES IN CORPORATIONS AND PROFESSIONAL SERVICE FIRMS (U.S. CLS. 100, 101 AND 102).

FIRST USE 9-9-2010; IN COMMERCE 9-9-2010.

PAM WILLIS, EXAMINING ATTORNEY

**CLASS 35—(Continued).**

SN 85-136,447. FORESEE RESULTS, INC., ANN ARBOR, MI.  
FILED 9-23-2010.

FORESEE RESULTS SOCIAL  
MEDIA VALUE CALCULATION

THE MARK CONSISTS OF STANDARD CHARACTERS WITHOUT CLAIM TO ANY PARTICULAR FONT, STYLE, SIZE, OR COLOR.

OWNER OF U.S. REG. NO. 2,807,916.

NO CLAIM IS MADE TO THE EXCLUSIVE RIGHT TO USE "SOCIAL MEDIA VALUE CALCULATION", APART FROM THE MARK AS SHOWN.

FOR DATA PROCESSING SERVICES OF DATA FROM USERS, AND FROM ACTIVITIES OF USERS VISITING WEBSITES OF OTHERS TO MEASURE CUSTOMER SATISFACTION AND ESTIMATE FUTURE BEHAVIORS OF USERS OF SUCH WEBSITES OF OTHERS, TO MEASURE AND ANALYZE DATA RELATED TO THE ACTIVITIES, ATTITUDES, BEHAVIORS, AND INTENTIONS OF THE USERS, AND TO QUANTIFY THE CONTRIBUTION OF THE SOCIAL MEDIA MARKETING OF OTHERS TO RESULTING CONVERSION ACTIVITIES, SALES, AND RETURN ON INVESTMENT (U.S. CLS. 100, 101 AND 102).

TRACY CROSS, EXAMINING ATTORNEY

**CLASS 35—(Continued).**

SN 85-137,532. AZAR DISTILLING, LLC, SAN ANTONIO, TX. FILED 9-24-2010.

CINCOLOGY

THE MARK CONSISTS OF STANDARD CHARACTERS WITHOUT CLAIM TO ANY PARTICULAR FONT, STYLE, SIZE, OR COLOR.

FOR WHOLESALE AND RETAIL DISTRIBUTORSHIP SERVICES IN THE FIELD OF ALCOHOLIC BEVERAGES (U.S. CLS. 100, 101 AND 102).

MATTHEW KLINE, EXAMINING ATTORNEY

SN 85-136,460. FORESEE RESULTS, INC., ANN ARBOR, MI.  
FILED 9-23-2010.

FORESEE SOCIAL MEDIA VALUE  
CALCULATION

THE MARK CONSISTS OF STANDARD CHARACTERS WITHOUT CLAIM TO ANY PARTICULAR FONT, STYLE, SIZE, OR COLOR.

OWNER OF U.S. REG. NO. 2,807,916.

NO CLAIM IS MADE TO THE EXCLUSIVE RIGHT TO USE "SOCIAL MEDIA VALUE CALCULATION", APART FROM THE MARK AS SHOWN.

FOR DATA PROCESSING SERVICES OF DATA FROM USERS, AND FROM ACTIVITIES OF USERS VISITING WEBSITES OF OTHERS TO MEASURE CUSTOMER SATISFACTION AND ESTIMATE FUTURE BEHAVIORS OF USERS OF SUCH WEBSITES OF OTHERS, TO MEASURE AND ANALYZE DATA RELATED TO THE ACTIVITIES, ATTITUDES, BEHAVIORS, AND INTENTIONS OF THE USERS, AND TO QUANTIFY THE CONTRIBUTION OF THE SOCIAL MEDIA MARKETING OF OTHERS TO RESULTING CONVERSION ACTIVITIES, SALES, AND RETURN ON INVESTMENT (U.S. CLS. 100, 101 AND 102).

TRACY CROSS, EXAMINING ATTORNEY

SN 85-137,828. SEXTON SUSAN, AUBURN, AL. FILED 9-24-2010.

The Genius Campaign

THE MARK CONSISTS OF STANDARD CHARACTERS WITHOUT CLAIM TO ANY PARTICULAR FONT, STYLE, SIZE, OR COLOR.

NO CLAIM IS MADE TO THE EXCLUSIVE RIGHT TO USE "CAMPAIGN", APART FROM THE MARK AS SHOWN.

FOR PUBLIC ADVOCACY TO PROMOTE AWARENESS OF THE IMPORTANCE OF EDUCATION (U.S. CLS. 100, 101 AND 102).

REBECCA EISINGER, EXAMINING ATTORNEY

**CLASS 35—(Continued).**

SN 85-138,546. PRGTS, LLC, ATLANTA, GA. FILED 9-27-2010.



OWNER OF U.S. REG. NO. 3,894,937.  
THE COLOR(S) GREEN AND BLACK IS/ARE CLAIMED AS A FEATURE OF THE MARK.

THE MARK CONSISTS OF THE LETTERS "PRGX" IN BLACK WITH A GREEN DIAMOND AT THE INTERSECTION OF THE TWO LINES THAT COMPRISE THE "X".

FOR PROVIDING BUSINESS AUDITING SERVICES IN THE NATURE OF RECOVERY AUDITING; BUSINESS CONSULTATION IN THE FIELD OF RECOVERY AUDITING; BUSINESS ADVISORY, CONSULTANCY AND INFORMATION SERVICES IN THE FIELD OF BUSINESS AND GOVERNMENT OPTIMIZATION; GOVERNMENT ADVISORY SERVICES, NAMELY, PROVIDING BUSINESS ADVICE AND ASSISTANCE TO GOVERNMENTAL AGENCIES AND DEPARTMENTS RELATING TO IDENTIFYING AND RECOVERING INAPPROPRIATE PAYMENTS; BUSINESS MANAGEMENT CONSULTING FEATURING SPECIALIZATION IN THE USE OF DATA EXTRACTION, TRANSFORMATION AND ANALYSIS CAPABILITIES, NAMELY, DATA PROCESSING, FOR THE REDUCTION OF COSTS AND IMPROVEMENT OF PROCUREMENT AND PAYMENT PROCESSES; PROVIDING BUSINESS CONSULTING, BUSINESS INFORMATION SERVICES IN THE FIELD OF ANALYTICS, BUSINESS OPERATIONAL AND BUSINESS PROCESS IMPROVEMENT AND OUTSOURCING SERVICES FOR THE FINANCE, ACCOUNTING AND PROCUREMENT FUNCTIONS OF COMMERCIAL AND GOVERNMENTAL ENTITIES; ACCOUNTING SERVICES (U.S. CLS. 100, 101 AND 102).

FIRST USE 1-21-2010; IN COMMERCE 1-21-2010.  
KATHLEEN M. VANSTON, EXAMINING ATTORNEY

SN 85-139,502. R&K SOLUTIONS, INC., ROANOKE, VA. FILED 9-28-2010.

**R&K FACILITY SUITE**

THE MARK CONSISTS OF STANDARD CHARACTERS WITHOUT CLAIM TO ANY PARTICULAR FONT, STYLE, SIZE, OR COLOR.

NO CLAIM IS MADE TO THE EXCLUSIVE RIGHT TO USE "FACILITY SUITE", APART FROM THE MARK AS SHOWN.

FOR FACILITY MANAGEMENT SERVICES, NAMELY, DATA MANAGEMENT FOR USE IN BUSINESS AND FACILITY MANAGEMENT AND OVERSIGHT, BUSINESS PROCESS DESIGN, DOCUMENT MANAGEMENT FOR USE IN BUSINESS AND FACILITY MANAGEMENT AND OVERSIGHT, BUSINESS INFORMATION REPORTING FOR USE IN BUSINESS AND FACILITY MANAGEMENT AND OVERSIGHT (U.S. CLS. 100, 101 AND 102).

MARK RADEMACHER, EXAMINING ATTORNEY

**CLASS 35—(Continued).**

SN 85-141,825. THE NASDAQ OMX GROUP, INC, NEW YORK, NY. FILED 9-30-2010.

**NASDAQ OMX ALPHA INDEX**

THE MARK CONSISTS OF STANDARD CHARACTERS WITHOUT CLAIM TO ANY PARTICULAR FONT, STYLE, SIZE, OR COLOR.

OWNER OF U.S. REG. NOS. 922,973, 2,156,075 AND OTHERS.

NO CLAIM IS MADE TO THE EXCLUSIVE RIGHT TO USE "ALPHA INDEX", APART FROM THE MARK AS SHOWN.

FOR FINANCIAL SERVICES, NAMELY, PROVIDING AND UPDATING AN INDEX OF SECURITIES VALUES, AND CLASSIFICATION, ANALYSIS, AND REPORTING THEREOF (U.S. CLS. 100, 101 AND 102).

MARK SPARACINO, EXAMINING ATTORNEY

SN 85-141,953. NIGEL ROSS, AKA CHU'ZU, TYLER, TX. FILED 9-30-2010.



THE MARK CONSISTS OF STANDARD CHARACTERS WITHOUT CLAIM TO ANY PARTICULAR FONT, STYLE, SIZE, OR COLOR.

THE NAME "CHU'ZU" IDENTIFIES A LIVING INDIVIDUAL WHOSE CONSENT IS OF RECORD.

FOR ENTERTAINMENT MARKETING SERVICES, NAMELY, MARKETING, PROMOTION AND ADVERTISING FOR INDEPENDENT RECORDING ARTISTS (U.S. CLS. 100, 101 AND 102).

ROSELLE HERRERA, EXAMINING ATTORNEY

SN 85-141,954. VINTAGE WINE DISTRIBUTOR, INC., SOLON, OH. FILED 9-30-2010.

**WINES OF DISTINCTION**

THE MARK CONSISTS OF STANDARD CHARACTERS WITHOUT CLAIM TO ANY PARTICULAR FONT, STYLE, SIZE, OR COLOR.

OWNER OF U.S. REG. NO. 1,545,921.

NO CLAIM IS MADE TO THE EXCLUSIVE RIGHT TO USE "WINES", APART FROM THE MARK AS SHOWN.

SEC. 2(F).

FOR DISTRIBUTORSHIP SERVICES IN THE FIELD OF WINE (U.S. CLS. 100, 101 AND 102).

FIRST USE 4-0-1972; IN COMMERCE 4-0-1972.

MARGERY A. TIERNEY, EXAMINING ATTORNEY

**CLASS 35—(Continued).**

SN 85-142,172. URBAN ENTERPRISES, INC., WESTERVILLE, OH. FILED 9-30-2010.



NO CLAIM IS MADE TO THE EXCLUSIVE RIGHT TO USE "ENTERPRISES", APART FROM THE MARK AS SHOWN.

THE COLOR(S) NAVY BLUE AND LIGHT GREEN IS/ARE CLAIMED AS A FEATURE OF THE MARK.

THE MARK CONSISTS OF A STYLIZED COMBINATION OF THE LETTERS "U" AND "E" TO THE LEFT OF THE STACKED TEXT "URBAN ENTERPRISES". THE COLOR NAVY BLUE APPEARS IN THE STYLIZED "UE" AND "ENTERPRISES" AND THE COLOR LIGHT GREEN APPEARS IN THE WORD "URBAN".

FOR ASSISTANCE, ADVISORY SERVICES AND CONSULTANCY WITH REGARD TO BUSINESS PLANNING, BUSINESS ANALYSIS, BUSINESS MANAGEMENT, BUSINESS ORGANIZATION, MARKETING AND CUSTOMER ANALYSIS (U.S. CLS. 100, 101 AND 102).

FIRST USE 12-19-2009; IN COMMERCE 12-19-2009.

CARYN GLASSER, EXAMINING ATTORNEY

**CLASS 35—(Continued).**

SN 85-142,745. NAVIGATE BOOMER MEDIA, LLC, SANTA MONICA, CA. FILED 10-1-2010.

## NAVIGATE BOOMER MEDIA

THE MARK CONSISTS OF STANDARD CHARACTERS WITHOUT CLAIM TO ANY PARTICULAR FONT, STYLE, SIZE, OR COLOR.

NO CLAIM IS MADE TO THE EXCLUSIVE RIGHT TO USE "BOOMER MEDIA", APART FROM THE MARK AS SHOWN.

FOR ON-LINE ADVERTISING ON A COMPUTER NETWORK AND INDIVIDUAL WEBSITES AND OTHER ON-LINE PROPERTIES AND MEDIA ACCESSED THROUGH THE INTERNET (U.S. CLS. 100, 101 AND 102).

FIRST USE 8-21-2009; IN COMMERCE 9-8-2009.

PRISCILLA MILTON, EXAMINING ATTORNEY

SN 85-142,729. NICKELL, INC., DBA GETFOUNDINTOWN, NOKOMIS, FL. FILED 10-1-2010.



THE COLOR(S) ORANGE; WHITE; GREY; BLACK; RED IS/ARE CLAIMED AS A FEATURE OF THE MARK.

THE MARK CONSISTS OF THE WORDING "GETFOUNDINTOWN" AND DESIGN. THE WORDING "GETFOUNDINTOWN" APPEARS IN WHITE WITHIN AN OBLONG ORANGE THOUGHT OR SPEECH BALLOON THAT POINTS TO A SMALL RED PEG. THE PEG IS LOCATED AT THE BOTTOM OF A SLANTED SQUARE GRID-MAP IN THE SECOND COLUMN. THE GRID-MAP IS MADE UP OF FOUR COLUMNS AND FIVE ROWS OF GREY GRID RECTANGLES THAT ARE SUPERIMPOSED ON A WHITE BACKGROUND AND THE SQUARE IS OUTLINED IN BLACK.

FOR ADVERTISING AND MARKETING (U.S. CLS. 100, 101 AND 102).

FIRST USE 8-15-2010; IN COMMERCE 8-20-2010.

MARLENE BELL, EXAMINING ATTORNEY

SN 85-143,533. CRYSTAL, RACHEL, MARINA DEL REY, CA. AND WORKMAN, KASSANDRA, MARINA DEL REY, CA. FILED 10-1-2010.



THE COLOR(S) BLACK, WHITE, PINK, AND GOLD IS/ARE CLAIMED AS A FEATURE OF THE MARK.

THE MARK CONSISTS OF PINK HEART SHAPED SWIRL WITH A BLACK LINE RUNNING THROUGH IT; SIX BLACK VERTICAL LINES WITH A GOLD SHADOW UNDER THE HEART SHAPED SWIRL AND ONE CURVED HORIZONTAL BLACK LINE UNDER THE SIX LINES; THE WORDS SUGAR BABIES IN BLACK OVER WHITE BACKGROUND AND THE I IN BABIES IS DOTTED WITH A PINK HEART SHAPED SWIRL.

FOR WHOLESALE AND RETAIL STORE SERVICES AND ONLINE RETAIL AND WHOLESALE STORE SERVICES FEATURING BAKED GOODS (U.S. CLS. 100, 101 AND 102).

FIRST USE 1-1-2010; IN COMMERCE 2-6-2010.

KIMBERLY PERRY, EXAMINING ATTORNEY



**CLASS 35—(Continued).**

SN 85-144,007. LEAGUE OF CONSERVATION VOTERS, WASHINGTON, DC. FILED 10-4-2010.

**CLASS 35—(Continued).**

SN 85-145,939. CITY OF WOODLAND PARK, WOODLAND PARK, CO. FILED 10-6-2010.

## Woodland Park



THE MARK CONSISTS OF STANDARD CHARACTERS WITHOUT CLAIM TO ANY PARTICULAR FONT, STYLE, SIZE, OR COLOR.

SEC. 2(F).

FOR CHAMBER OF COMMERCE SERVICES, NAMELY, PROMOTING BUSINESS AND TOURISM IN THE WOODLAND PARK, COLORADO AREA; CONVENTION AND VISITORS BUREAU SERVICES, NAMELY, PROMOTING BUSINESS AND TOURISM IN THE WOODLAND PARK, COLORADO AREA; CONVENTION AND VISITORS BUREAU SERVICES, NAMELY, PROMOTING BUSINESS, TOURISM AND THE HOLDING OF CONVENTIONS IN THE WOODLAND PARK, COLORADO AREA; CONVENTION AND VISITORS BUREAU SERVICES, NAMELY, PROMOTING CONVENTIONS AND TOURISM IN THE WOODLAND PARK, COLORADO AREA; CONVENTION AND VISITORS BUREAU SERVICES, NAMELY, PROMOTING TOURISM, BUSINESS AND CONVENTIONS IN AND AROUND THE WOODLAND PARK, COLORADO AREA; MARKETING, ADVERTISING AND PROMOTING THE GOODS AND SERVICES OF OTHERS IN THE FIELD OF TRAVEL AND TOURISM, NAMELY, PROVIDING INFORMATION VIA MAIL AND ELECTRONIC MAIL; PROMOTING RECREATION AND TOURISM IN THE WOODLAND PARK, COLORADO AREA; PROMOTING TOURISM IN THE WOODLAND PARK, COLORADO AREA; PUBLIC RELATIONS, ADVERTISING AND MARKETING SERVICES FOR THE TOURISM AND CONVENTION INDUSTRY, NAMELY, ORGANIZING AND HOSTING SITE INSPECTIONS AND FAMILIARIZATION TOURS FOR WHOLESALERS, TOUR OPERATORS, TRAVEL AGENTS, MEETING AND INCENTIVE TRAVEL PLANNERS AND TRAVEL MEDIA (U.S. CLS. 100, 101 AND 102).

FIRST USE 6-6-1891; IN COMMERCE 6-6-1891.

BRENDAN REGAN, EXAMINING ATTORNEY

---

SN 85-146,405. QUESTCARE MEDICAL SERVICES, P.A., DALLAS, TX. FILED 10-6-2010.

THE COLOR(S) RED, WHITE AND GREEN IS/ARE CLAIMED AS A FEATURE OF THE MARK.

THE MARK CONSISTS OF A FIVE-POINT STAR SPLIT VERTICALLY INTO TWO HALVES. THE LEFT SIDE OF THE STAR AND THE STEM FORM HALF OF A GREEN LEAF WITH VEINS IN WHITE, AND THE RIGHT SIDE OF THE STAR APPEARS IN ALTERNATING RED AND WHITE HORIZONTAL STRIPES.

FOR ASSOCIATION SERVICES, NAMELY, PROMOTING THE INTERESTS OF THOSE CONCERNED WITH CONSERVATION ISSUES BY INFORMING THE PUBLIC ABOUT ELECTED OFFICIALS' RECORDS ON THESE ISSUES AND SUPPORTING PRO-ENVIRONMENTAL CANDIDATES; PROMOTING PUBLIC AWARENESS OF THE NEED FOR SOUND ENVIRONMENTAL POLICIES AND THE NEED TO ELECT PRO-ENVIRONMENTAL CANDIDATES WHO WILL ADOPT AND IMPLEMENT SUCH POLICIES (U.S. CLS. 100, 101 AND 102).

FIRST USE 2-1-1991; IN COMMERCE 2-1-1991.

MARCIE MILONE, EXAMINING ATTORNEY

## LEVEL 5 HEALTHCARE

THE MARK CONSISTS OF STANDARD CHARACTERS WITHOUT CLAIM TO ANY PARTICULAR FONT, STYLE, SIZE, OR COLOR.

NO CLAIM IS MADE TO THE EXCLUSIVE RIGHT TO USE "HEALTHCARE", APART FROM THE MARK AS SHOWN.

FOR MEDICAL PRACTICE BUSINESS MANAGEMENT FOR OTHERS; HEALTHCARE BILLING SERVICES (U.S. CLS. 100, 101 AND 102).

GINA FINK, EXAMINING ATTORNEY

**CLASS 35—(Continued).**

SN 85-146,705. SMART DESIGN LLC, NEW YORK, NY. FILED 10-6-2010.

## SMART DESIGN

THE MARK CONSISTS OF STANDARD CHARACTERS WITHOUT CLAIM TO ANY PARTICULAR FONT, STYLE, SIZE, OR COLOR.

OWNER OF U.S. REG. NOS. 2,619,722, 2,673,769 AND OTHERS.

NO CLAIM IS MADE TO THE EXCLUSIVE RIGHT TO USE "DESIGN", APART FROM THE MARK AS SHOWN.

FOR BRANDING SERVICES, NAMELY, CONSULTING AND DEVELOPMENT OF BRANDS AND BRAND STRATEGIES (U.S. CLS. 100, 101 AND 102).

FIRST USE 8-31-1985; IN COMMERCE 8-31-1985.

PRISCILLA MILTON, EXAMINING ATTORNEY

SN 85-146,890. POPULAR STRANGERS, LODI, NJ. FILED 10-7-2010.



THE COLOR(S) BLUE, LIGHT BLUE, BLACK, GOLD AND SILVER IS/ARE CLAIMED AS A FEATURE OF THE MARK.

THE MARK CONSISTS OF THE WORDING "POPULAR STRANGERS" APPEARING IN BLACK LETTERS ON A GOLD BANNER, BEHIND THE BANNER APPEARS TWO KEYS, THE LEFT SIDE KEY APPEARS IN THE COLOR GOLD AND THE RIGHT SIDE KEY APPEARS IN SILVER, AND A GLOBE WITH BLUE CONTINENTS AND LIGHT BLUE WATER.

FOR PROMOTIONAL SERVICES, NAMELY, PROVIDING A WEBSITE AT WHICH ARTISTS CAN SHOWCASE THEIR TALENTS VIA AN ONLINE PORTFOLIO (U.S. CLS. 100, 101 AND 102).

SAMUEL E. SHARPER JR., EXAMINING ATTORNEY

**CLASS 35—(Continued).**

SN 85-146,954. MELANIE JEAN BURKE PLAGMANN, WESTLAKE VILLAGE, CA. FILED 10-7-2010.



OWNER OF U.S. REG. NO. 3,456,304.

THE COLOR(S) GREEN AND BLUE IS/ARE CLAIMED AS A FEATURE OF THE MARK.

THE MARK CONSISTS OF THE WORDING "CFO4U" WITH A DESIGN TO THE RIGHT OF THE WORDING COMPRISED OF A PERSON POINTING TO THE LEFT. THE LETTERS "CFO" ARE IN GREEN AND THE LETTERS "4U" AND DESIGN ARE IN BLUE.

FOR ACCOUNTING CONSULTATION; ACCOUNTING SERVICES; ADMINISTRATION, BILLING AND RECONCILIATION OF ACCOUNTS ON BEHALF OF OTHERS; ADMINISTRATIVE ACCOUNTING; BOOKKEEPING; BUSINESS ASSISTANCE, ADVISORY SERVICES AND CONSULTANCY IN THE FIELDS OF BUDGETING, BOOKKEEPING, PREPARATION AND FILING OF CLAIMS, PREPARATION AND FILING OF FORMS, BILL PAYING, ORGANIZING AND PROCESSING PAPERWORK, DEVELOPMENT OF PLAN TO ACHIEVE GOALS AND REFERRAL SERVICES TO BEREAVEMENT COUNSELORS; BUSINESS INFORMATION AND ACCOUNTING ADVISORY SERVICES; COMPUTERIZED ACCOUNTING SERVICES; FRANCHISE SERVICES, NAMELY, OFFERING BUSINESS MANAGEMENT ASSISTANCE IN THE ESTABLISHMENT AND OPERATION OF BOOKKEEPING AND ACCOUNTING SERVICES FOR INDIVIDUALS AND BUSINESSES (U.S. CLS. 100, 101 AND 102).

FIRST USE 1-1-2005; IN COMMERCE 1-1-2005.

CURTIS FRENCH, EXAMINING ATTORNEY

SN 85-146,989. GOODWILL INDUSTRIES OF NORTH CENTRAL WISCONSIN, INC., MENASHA, WI. FILED 10-7-2010.

## GOODS MADE GOOD

THE MARK CONSISTS OF STANDARD CHARACTERS WITHOUT CLAIM TO ANY PARTICULAR FONT, STYLE, SIZE, OR COLOR.

OWNER OF U.S. REG. NO. 3,866,637.

FOR RETAIL AND WHOLESALE STORE SERVICES FEATURING HOME ACCESSORIES MADE FROM RECLAIMED CLOTHING, HOUSEWARES, AND BUILDING MATERIALS (U.S. CLS. 100, 101 AND 102).

MICHELLE DUBOIS, EXAMINING ATTORNEY

**CLASS 35—(Continued).**

SN 85-147,295. ADAPTU LLC, PORTLAND, OR. FILED 10-7-2010.

# ADAPTU

THE MARK CONSISTS OF STANDARD CHARACTERS WITHOUT CLAIM TO ANY PARTICULAR FONT, STYLE, SIZE, OR COLOR.

FOR PROVIDING BILLING ALERTS; CUSTOMER SERVICE IN THE FIELD OF ONLINE BANKING, PERSONAL FINANCE, FINANCIAL LIFE PLANNING AND MANAGEMENT, AND RETIREMENT PLANNING; PROVIDING AN ON-LINE COMPUTER WEBSITE THAT PROVIDES BANKING AND FINANCIAL TRANSACTION DATA, ACCOUNT MANAGEMENT, FINANCIAL REPORTING, ACCOUNTING FEATURES AND RELATED REFERENCE INFORMATION IN THE FIELD OF RETAIL BANKING (U.S. CLS. 100, 101 AND 102).

MATTHEW KLINE, EXAMINING ATTORNEY

---

SN 85-147,352. SPELLBRAND INC., DBA LOGO DESIGN WORKS, CLEVELAND, OH. FILED 10-7-2010.



NO CLAIM IS MADE TO THE EXCLUSIVE RIGHT TO USE "LOGO", APART FROM THE MARK AS SHOWN.

THE COLOR(S) BLACK, GRAY, YELLOW, ORANGE, GREEN, BLUE AND PURPLE IS/ARE CLAIMED AS A FEATURE OF THE MARK.

THE MARK CONSISTS OF THE WORDING "LOGO DESIGNWORKS" IN GRAY, AND THE DESIGN OF A YELLOW HUMMING BIRD WITH OUTSTRETCHED YELLOW, GREEN, BLUE AND PURPLE WINGS, BLACK EYES, AND AN ORANGE BELLY, ALL OF THE FOREGOING SET AGAINST A BLACK BACKGROUND.

FOR ADVERTISING SERVICES, NAMELY, CREATING CORPORATE LOGOS FOR OTHERS; MARKETING AND BRANDING SERVICES, NAMELY, PERFORMING CONSUMER INSIGHT AND BRAND STRATEGY OF COMPANY LOGOS; PROVIDING ADVERTISING, MARKETING AND PROMOTIONAL SERVICES, NAMELY, DEVELOPMENT OF ADVERTISING CAMPAIGNS FOR INTERNET WEBSITES, TV, PRINT MAGAZINES AND STATIONERY DESIGN (U.S. CLS. 100, 101 AND 102).

FIRST USE 9-15-2010; IN COMMERCE 9-15-2010.

SEAN CROWLEY, EXAMINING ATTORNEY

**CLASS 35—(Continued).**

SN 85-147,373. ADAPTU LLC, PORTLAND, OR. FILED 10-7-2010.



THE COLOR(S) GREEN, BLUE, BROWN, BEIGE, GRAY, RED, YELLOW AND ORANGE IS/ARE CLAIMED AS A FEATURE OF THE MARK.

THE MARK CONSISTS OF A GREEN ARROW POINTING INTO AN ABSTRACT BUBBLE DIAGRAM, WHICH CONTAINS THE COLORS BLUE, BROWN, BEIGE, GRAY, RED, YELLOW AND ORANGE, IN A PIE CHART DESIGN.

FOR PROVIDING BILLING ALERTS; CUSTOMER SERVICE IN THE FIELD OF ONLINE BANKING, PERSONAL FINANCE, FINANCIAL LIFE PLANNING AND MANAGEMENT, AND RETIREMENT PLANNING; PROVIDING AN ON-LINE COMPUTER WEBSITE THAT PROVIDES BANKING AND FINANCIAL TRANSACTION DATA, ACCOUNT MANAGEMENT, FINANCIAL REPORTING, ACCOUNTING FEATURES AND RELATED REFERENCE INFORMATION IN THE FIELD OF RETAIL BANKING (U.S. CLS. 100, 101 AND 102).

MATTHEW KLINE, EXAMINING ATTORNEY

---

SN 85-149,315. ENDURAPACK, LLC, WESTBURY, NY. FILED 10-11-2010.



OWNER OF U.S. REG. NOS. 3,338,759 AND 3,347,136.  
NO CLAIM IS MADE TO THE EXCLUSIVE RIGHT TO USE "FLEXIBLE PACKAGING", APART FROM THE MARK AS SHOWN.

THE COLOR(S) ORANGE, BLUE AND GRAY IS/ARE CLAIMED AS A FEATURE OF THE MARK.

THE MARK CONSISTS OF THE WORD "ENDURAPACK" SET IN A STYLIZED FONT WITH THE PHRASE "ENDURA" SET IN ORANGE AND THE PHRASE "PACK" SET IN BLUE. TO THE LEFT OF THE PHRASE "ENDURAPACK" IS A STYLIZED BLUE OUTLINE OF A SHOPPING BAG WITH A CURVED HANDLE. THE OUTLINE OF THE SHOPPING BAG IS FASHIONED WITH DASHED BLUE LINES. BELOW THE WORD ENDURAPACK IS THE PHRASE "FLEXIBLE PACKAGING. SOLID RESULTS." IN A GRAY FONT.

FOR WHOLESALE DISTRIBUTORSHIPS FEATURING PAPER BAGS, PLASTIC BAGS AND NONWOVEN BAGS (U.S. CLS. 100, 101 AND 102).

SHAUNIA CARLYLE, EXAMINING ATTORNEY

**CLASS 35—(Continued).**

SN 85-149,387. ONE TEAM GLOBAL, LEHI, UT. FILED 10-11-2010.

SUCCESS SUMMIT

THE MARK CONSISTS OF STANDARD CHARACTERS WITHOUT CLAIM TO ANY PARTICULAR FONT, STYLE, SIZE, OR COLOR.

NO CLAIM IS MADE TO THE EXCLUSIVE RIGHT TO USE "SUMMIT", APART FROM THE MARK AS SHOWN.

FOR ORGANIZING AND CONDUCTING BUSINESS CONFERENCES AND BUSINESS EVENTS, NAMELY, EXHIBITIONS, BOTH OF THE FOREGOING FOR BUSINESS PURPOSES (U.S. CLS. 100, 101 AND 102).

FIRST USE 6-1-2010; IN COMMERCE 6-1-2010.

NANCY CLARKE, EXAMINING ATTORNEY

**CLASS 35—(Continued).**

SN 85-149,569. PEST WIZARD, INC., REDLANDS, CA. FILED 10-11-2010.



NO CLAIM IS MADE TO THE EXCLUSIVE RIGHT TO USE "PEST", APART FROM THE MARK AS SHOWN.

THE MARK CONSISTS OF A MANTIS TYPE INSECT STANDING RIGHT PROFILE, DRESSED IN WIZARD GOWN, GLOVES AND HAT AND HOLDING WAND AND FLASK WITH THE WORDS "PEST WIZARD" ON THE RIGHT; STARS ON GOWN AND HAT AND OUTLINE OF VARYING THICKNESS.

FOR WHOLESALE STORES FEATURING INSECT TRAPS AND LURES (U.S. CLS. 100, 101 AND 102).

FIRST USE 4-13-2001; IN COMMERCE 4-13-2001.

DAWN FELDMAN, EXAMINING ATTORNEY

SN 85-149,585. WILLIAM HITE, TORRANCE, CA. FILED 10-11-2010.

SN 85-149,470. FORTE, LLC, MINNEAPOLIS, MN. FILED 10-11-2010.

FIND WHAT YOU'VE BEEN MISSING



THE MARK CONSISTS OF STANDARD CHARACTERS WITHOUT CLAIM TO ANY PARTICULAR FONT, STYLE, SIZE, OR COLOR.

FOR CONSULTATION IN THE AREA OF PROBATE FILINGS, PROBATE SEARCHES, AND PROBATE RECOVERY SOLUTIONS, NAMELY, PROVIDING ESTATE DATA MANAGEMENT SERVICES TO OTHERS IN THE NATURE OF LOCATING ESTATES AND ORGANIZING THEM INTO A DATABASE OF EXISTING ESTATE ACCOUNTS, MATCHING CUSTOMER ACCOUNTS TO ESTATE RECORDS IN A DATABASE, AND MAINTAINING A DATABASE THAT AUTOMATES AND PRIORITIZES THE CLAIM GENERATION AND FILING PROCESS (U.S. CLS. 100, 101 AND 102).

FIRST USE 4-18-2010; IN COMMERCE 4-18-2010.

HAI-LY LAM, EXAMINING ATTORNEY

NO CLAIM IS MADE TO THE EXCLUSIVE RIGHT TO USE "ELECTION CANDIDATES", APART FROM THE MARK AS SHOWN.

THE MARK CONSISTS OF THE WORDS "ELECTION CANDIDATES" REPEATED AROUND A SILHOUETTE OF GEORGE WASHINGTON, AN AMERICAN EAGLE, AND AN AMERICAN FLAG.

FOR PROVIDING A WEBSITE FEATURING INFORMATION ABOUT POLITICAL ISSUES; PROVIDING AN INTERNET WEBSITE FEATURING NEWS AND INFORMATION IN THE FIELD OF NATIONAL AND INTERNATIONAL POLITICS (U.S. CLS. 100, 101 AND 102).

FIRST USE 10-11-2010; IN COMMERCE 10-11-2010.

MARK SPARACINO, EXAMINING ATTORNEY

**CLASS 35—(Continued).**

SN 85-149,806. HAPPY BELLY BAGS, LLC, WEXFORD, PA. FILED 10-11-2010.

**HAPPY BELLY BAGS**

THE MARK CONSISTS OF STANDARD CHARACTERS WITHOUT CLAIM TO ANY PARTICULAR FONT, STYLE, SIZE, OR COLOR.

NO CLAIM IS MADE TO THE EXCLUSIVE RIGHT TO USE "BAGS", APART FROM THE MARK AS SHOWN.

FOR PROVIDING A WEBSITE USED TO PLACE ON-LINE COMMERCIAL ORDERS IN THE FIELD OF ASSORTED BAGS, BASKETS AND KITS CONTAINING ORGANIC, GLUTEN-FREE, ALLERGEN-FREE AND OTHER HEALTHFUL FOOD PRODUCTS (U.S. CLS. 100, 101 AND 102).

FIRST USE 10-9-2010; IN COMMERCE 10-9-2010.  
LINDA MICKLEBURGH, EXAMINING ATTORNEY

SN 85-150,119. PRIBYL, STEVEN V., CULVER CITY, CA. FILED 10-11-2010.

**cogiwo**

THE MARK CONSISTS OF STANDARD CHARACTERS WITHOUT CLAIM TO ANY PARTICULAR FONT, STYLE, SIZE, OR COLOR.

THE WORDING "COGIWO" HAS NO MEANING IN A FOREIGN LANGUAGE.

FOR COMPUTERIZED ON-LINE GIFT ORDERING SERVICES FOR OTHERS WHEREBY THE ADDRESS INFORMATION OF THE SENDER AND THE RECEIVER ARE KEPT CONFIDENTIAL (U.S. CLS. 100, 101 AND 102).

FIRST USE 10-1-2008; IN COMMERCE 10-1-2010.  
EVELYN BRADLEY, EXAMINING ATTORNEY

SN 85-150,823. BRIGGS AND MORGAN, PROFESSIONAL ASSOCIATION, MINNEAPOLIS, MN. FILED 10-12-2010.

**NORTH STAR ALLIANCE**

THE MARK CONSISTS OF STANDARD CHARACTERS WITHOUT CLAIM TO ANY PARTICULAR FONT, STYLE, SIZE, OR COLOR.

NO CLAIM IS MADE TO THE EXCLUSIVE RIGHT TO USE "ALLIANCE", APART FROM THE MARK AS SHOWN. FOR ATTORNEY REFERRALS (U.S. CLS. 100, 101 AND 102).

FIRST USE 6-24-2010; IN COMMERCE 6-24-2010.  
JOHN E. MICHOS, EXAMINING ATTORNEY

**CLASS 35—(Continued).**

SN 85-150,946. JOHN E. HUTCHESON, DBA BOOM! MODELS & TALENT, SAN FRANCISCO, CA. FILED 10-12-2010.



NO CLAIM IS MADE TO THE EXCLUSIVE RIGHT TO USE "MODELS & TALENT", APART FROM THE MARK AS SHOWN.

THE COLOR(S) BLACK, WHITE, YELLOW IS/ARE CLAIMED AS A FEATURE OF THE MARK.

THE MARK CONSISTS OF STYLIZED LETTERS "BOOM!" WITH AN EXCLAMATION POINT THAT IS CAPITAL LETTERS IN BOLD BLACK WITH WHITE EDGING ALONG PARTS OF THE LETTERS. A 12 POINTED CARTOON LIKE EXPLOSION DRAWING IN YELLOW WITH A WHITE-LIGHT EFFECT SURROUNDING IT. A BLACK BOX THAT HAS ALL THE DESIGNS AND WORDS INSIDE. STYLIZED "MODELS & TALENT" IN WHITE BELOW THE WORD "BOOM!" & THE CARTOON LIKE 12 POINT EXPLOSION. FOR TALENT AGENCIES (U.S. CLS. 100, 101 AND 102).

FIRST USE 1-12-1994; IN COMMERCE 10-1-1995.  
ANDREA HACK, EXAMINING ATTORNEY

SN 85-151,101. PASTELES CAPY, LONG ISLAND CITY, NY. FILED 10-12-2010.



NO CLAIM IS MADE TO THE EXCLUSIVE RIGHT TO USE "PASTELES" OR "HECHOS EN CASA", APART FROM THE MARK AS SHOWN.

THE MARK CONSISTS OF THE STYLIZED WORDING "PASTELES CAPY" SET AGAINST AN OVAL DESIGN NEXT TO A DESIGN OF A SMILEY FACE WITH A CHEF'S HAT AND THE WORDING "HECHOS EN CASA" UNDERNEATH THE OVAL.

THE ENGLISH TRANSLATION OF "PASTELES" IN THE MARK IS "CAKES". THE ENGLISH TRANSLATION OF "HECHOS EN CASA" IN THE MARK IS "HOMEMADE". FOR RETAIL BAKERY SHOPS (U.S. CLS. 100, 101 AND 102).

FIRST USE 9-15-1984; IN COMMERCE 9-15-1984.  
LAURIE KAUFMAN, EXAMINING ATTORNEY

**CLASS 35—(Continued).**

SN 85-151,152. STURMAN, MIMI S, DBA MIMI'S MERCANTILE LLC, SHORELINE, WA. FILED 10-13-2010.

## Mimi's Mercantile

THE MARK CONSISTS OF STANDARD CHARACTERS WITHOUT CLAIM TO ANY PARTICULAR FONT, STYLE, SIZE, OR COLOR.

NO CLAIM IS MADE TO THE EXCLUSIVE RIGHT TO USE "MERCANTILE", APART FROM THE MARK AS SHOWN.

THE NAME "MIMI" IDENTIFIES A LIVING INDIVIDUAL WHOSE CONSENT IS OF RECORD.

FOR ON-LINE RETAIL GIFT SHOPS; ON-LINE RETAIL STORE SERVICES FEATURING HOUSEHOLD GOODS (U.S. CLS. 100, 101 AND 102).

FIRST USE 11-1-2008; IN COMMERCE 11-1-2008.

JANICE L. MCMORROW, EXAMINING ATTORNEY

**CLASS 35—(Continued).**

SN 85-152,583. COINCO, INC., DBA MORCO, COCHRANTON, PA. FILED 10-14-2010.

## HERITAGE AMERICA

THE MARK CONSISTS OF STANDARD CHARACTERS WITHOUT CLAIM TO ANY PARTICULAR FONT, STYLE, SIZE, OR COLOR.

NO CLAIM IS MADE TO THE EXCLUSIVE RIGHT TO USE "AMERICA", APART FROM THE MARK AS SHOWN.

FOR WHOLESALE AND RETAIL STORE SERVICES AND ONLINE RETAIL AND WHOLESALE STORE SERVICES FEATURING THERMOMETERS, RULERS, LUGGAGE TAGS, CALENDARS, WALL CALENDARS, DESK CALENDARS, BLOOD PRESSURE RECORDERS, PENS, PENCILS, KEY CHAINS, KEY RINGS, KEY HOLDERS, BEVERAGE AND FOOD ACCESSORIES, CAN OPENERS, BEVERAGE CAN CAPS, CLIPBOARDS, MAGNETIC CLIPS, DECORATIVE MAGNETS, RAIN GAUGES, LIGHT SWITCH COVERS, SHOE HORNS, FLY SWATTERS, GOLF TEES, PILL BOXES, PILL HOLDERS, CREDIT CARD ORGANIZERS, PET FOOD LIDS, MAGNIFYING GLASSES, LICENSE PLATES, AUTOMOTIVE ACCESSORIES, GOLF PRODUCTS, DESK ACCESSORIES, WRITING INSTRUMENTS, AND PET SUPPLIES (U.S. CLS. 100, 101 AND 102).

WILLIAM VERHOSEK, EXAMINING ATTORNEY

SN 85-153,012. SINH HAK HOUT, INC., HACIENDA HEIGHTS, CA. FILED 10-14-2010.

SN 85-152,139. DEL INDUSTRIES, INC., SAN LUIS OBISPO, CA. FILED 10-13-2010.

## DELAQUATICS OZONE SANITATION PROGRAM



THE MARK CONSISTS OF STANDARD CHARACTERS WITHOUT CLAIM TO ANY PARTICULAR FONT, STYLE, SIZE, OR COLOR.

OWNER OF U.S. REG. NOS. 2,836,411, 3,856,538 AND OTHERS.

NO CLAIM IS MADE TO THE EXCLUSIVE RIGHT TO USE "OZONE SANITATION PROGRAM", APART FROM THE MARK AS SHOWN.

FOR MARKETING SERVICES, NAMELY, PROMOTING COMMERCIAL POOL SANITATION SYSTEMS BY DISTRIBUTING ADVERTISING MATERIALS THROUGH A VARIETY OF METHODS (U.S. CLS. 100, 101 AND 102).

FIRST USE 9-0-2010; IN COMMERCE 9-0-2010.

MARGERY A. TIERNEY, EXAMINING ATTORNEY

NO CLAIM IS MADE TO THE EXCLUSIVE RIGHT TO USE "24" OR "CONVENIENCE", APART FROM THE MARK AS SHOWN.

THE COLOR(S) GREEN, WHITE, AND RED IS/ARE CLAIMED AS A FEATURE OF THE MARK.

THE MARK CONSISTS OF A GREEN ARROW FORMING A CIRCLE WITH A WHITE BACKGROUND INSIDE THE CIRCLE WITH THE STYLIZED WORD "CONVENIENCE" APPEARING IN RED ON THE BOTTOM OF THE CIRCULAR ARROW AND THE STYLIZED NUMBERS "24" APPEARING IN RED INSIDE THE CIRCULAR ARROW.

FOR RETAIL CONVENIENCE STORES (U.S. CLS. 100, 101 AND 102).

FIRST USE 8-1-2010; IN COMMERCE 8-1-2010.

FONG HSU, EXAMINING ATTORNEY

**CLASS 35—(Continued).**

SN 85-153,182. VALUECLICK, INC., WESTLAKE VILLAGE, CA. FILED 10-14-2010.

**GROCERY CONNECT**

THE MARK CONSISTS OF STANDARD CHARACTERS WITHOUT CLAIM TO ANY PARTICULAR FONT, STYLE, SIZE, OR COLOR.

NO CLAIM IS MADE TO THE EXCLUSIVE RIGHT TO USE "GROCERY", APART FROM THE MARK AS SHOWN.

FOR INFORMATION AND DATA COMPILING AND ANALYZING RELATING TO BUSINESS MANAGEMENT AND ADVERTISING; INFORMATION AND DATA COMPILING VIA COMPUTER AND ANALYZING RELATING TO BUSINESS MANAGEMENT AND ADVERTISING; BUSINESS MANAGEMENT OF ONLINE ADVERTISING FOR OTHERS; BUSINESS MANAGEMENT OF ONLINE ADVERTISING CAMPAIGNS FOR OTHERS BY TRACKING, ANALYZING AND REPORTING OF CONSUMER DATA, DEMOGRAPHICS, AND CONSUMER BEHAVIORAL INFORMATION; DISSEMINATION OF ADVERTISING FOR OTHERS VIA A SECURED GLOBAL COMPUTER NETWORK (U.S. CLS. 100, 101 AND 102).

FIRST USE 10-14-2010; IN COMMERCE 10-14-2010.

ANDREW RHIM, EXAMINING ATTORNEY

**CLASS 35—(Continued).**

SN 85-153,474. OMAHA STEAKS INTERNATIONAL, INC., OMAHA, NE. FILED 10-15-2010.

**OMAHA FRESH BY OMAHA STEAKS**

THE MARK CONSISTS OF STANDARD CHARACTERS WITHOUT CLAIM TO ANY PARTICULAR FONT, STYLE, SIZE, OR COLOR.

OWNER OF U.S. REG. NOS. 2,002,499, 3,774,260 AND OTHERS.

NO CLAIM IS MADE TO THE EXCLUSIVE RIGHT TO USE "FRESH" AND "STEAKS", APART FROM THE MARK AS SHOWN.

SEC. 2(F) AS TO "OMAHA".

FOR MAIL ORDER CATALOG SERVICES FEATURING FOOD AND FOOD RELATED ITEMS; ON-LINE RETAIL STORE SERVICES FEATURING FOOD AND FOOD RELATED ITEMS; RETAIL STORES FEATURING FOOD AND FOOD RELATED ITEMS; WHOLESALE FOOD DISTRIBUTORSHIP SERVICES (U.S. CLS. 100, 101 AND 102).

DANIEL CAPSHAW, EXAMINING ATTORNEY

SN 85-153,488. OMAHA STEAKS INTERNATIONAL, INC., OMAHA, NE. FILED 10-15-2010.

**OMAHA FRESH ANGUS BY OMAHA STEAKS**

THE MARK CONSISTS OF STANDARD CHARACTERS WITHOUT CLAIM TO ANY PARTICULAR FONT, STYLE, SIZE, OR COLOR.

OWNER OF U.S. REG. NOS. 2,002,499, 3,857,500 AND OTHERS.

NO CLAIM IS MADE TO THE EXCLUSIVE RIGHT TO USE "FRESH ANGUS" AND "STEAKS", APART FROM THE MARK AS SHOWN.

SEC. 2(F) AS TO "OMAHA".

FOR MAIL ORDER CATALOG SERVICES FEATURING FOOD AND FOOD RELATED ITEMS; ON-LINE RETAIL STORE SERVICES FEATURING FOOD AND FOOD RELATED ITEMS; RETAIL STORES FEATURING FOOD AND FOOD RELATED ITEMS; WHOLESALE FOOD DISTRIBUTORSHIP SERVICES (U.S. CLS. 100, 101 AND 102).

DANIEL CAPSHAW, EXAMINING ATTORNEY

SN 85-153,314. THOMAS, SIMONE, MAPLEWOOD, NJ. FILED 10-15-2010.

**PLUM PUBLIC RELATIONS**

THE MARK CONSISTS OF STANDARD CHARACTERS WITHOUT CLAIM TO ANY PARTICULAR FONT, STYLE, SIZE, OR COLOR.

NO CLAIM IS MADE TO THE EXCLUSIVE RIGHT TO USE "PUBLIC RELATIONS", APART FROM THE MARK AS SHOWN.

FOR PUBLIC RELATIONS (U.S. CLS. 100, 101 AND 102).

REBECCA SMITH, EXAMINING ATTORNEY

**CLASS 35—(Continued).**

SN 85-153,834. CAPITAL RELOCATION SERVICES, LLC, STERLING, VA. FILED 10-15-2010.

## Low-Stress Relocation Process

THE MARK CONSISTS OF STANDARD CHARACTERS WITHOUT CLAIM TO ANY PARTICULAR FONT, STYLE, SIZE, OR COLOR.

NO CLAIM IS MADE TO THE EXCLUSIVE RIGHT TO USE "RELOCATION PROCESS", APART FROM THE MARK AS SHOWN.

FOR BUSINESS SERVICES, NAMELY, FORMULATION OF BEST PRACTICES FOR PLANNING AND IMPLEMENTING MOVES OF HOMES AND OFFICES THROUGH THE USE OF COST ANALYSIS AND BUSINESS STUDIES (U.S. CLS. 100, 101 AND 102).

FIRST USE 6-1-2006; IN COMMERCE 6-1-2006.

DAVID YONTEF, EXAMINING ATTORNEY

SN 85-153,845. BALLOTBOOK CORP., PFLUGERVILLE, TX. FILED 10-15-2010.



THE COLOR(S) BLUE AND RED IS/ARE CLAIMED AS A FEATURE OF THE MARK.

THE MARK CONSISTS OF THE WORD "BALLOTBOOK" IN BLUE LETTERING WITH RED CHECKMARK OVER THE LETTER "O" IN THE WORD "BALLOT".

FOR DESIGN OF ADVERTISING BROCHURES FOR OTHERS; DISSEMINATION OF ADVERTISING MATERIAL; PROVIDING A WEBSITE FEATURING INFORMATION ABOUT POLITICAL ISSUES; PROVIDING AN INTERNET WEBSITE FEATURING NEWS AND INFORMATION IN THE FIELD OF NATIONAL AND INTERNATIONAL POLITICS (U.S. CLS. 100, 101 AND 102).

WILLIAM ROSSMAN, EXAMINING ATTORNEY

SN 85-153,889. CAPITAL RELOCATION SERVICES, LLC, STERLING, VA. FILED 10-15-2010.

## LSRP

THE MARK CONSISTS OF STANDARD CHARACTERS WITHOUT CLAIM TO ANY PARTICULAR FONT, STYLE, SIZE, OR COLOR.

FOR BUSINESS SERVICES, NAMELY, FORMULATION OF BEST PRACTICES FOR PLANNING AND IMPLEMENTING MOVES OF HOMES AND OFFICES THROUGH THE USE OF COST ANALYSIS AND BUSINESS STUDIES (U.S. CLS. 100, 101 AND 102).

DAVID YONTEF, EXAMINING ATTORNEY

**CLASS 35—(Continued).**

SN 85-154,554. ADAM SUMMERS, GLEN BURNIE, MD. FILED 10-17-2010.



THE MARK CONSISTS OF THE WORD "PATIENT" AND THE WORD "APPROVED". THE LETTER "V" IN THE WORD "APPROVED" IS STYLIZED TO APPEAR AS A CHECK-MARK.

FOR CONNECTING QUALIFIED SERVICE PROVIDERS WITH CONSUMERS (U.S. CLS. 100, 101 AND 102).

FIRST USE 11-28-2007; IN COMMERCE 11-28-2007.

HANNO RITTNER, EXAMINING ATTORNEY

SN 85-154,555. DANIEL JOHN T, LAWRENCEVILLE, GA. FILED 10-17-2010.

## Bless America

THE MARK CONSISTS OF STANDARD CHARACTERS WITHOUT CLAIM TO ANY PARTICULAR FONT, STYLE, SIZE, OR COLOR.

NO CLAIM IS MADE TO THE EXCLUSIVE RIGHT TO USE "AMERICA", APART FROM THE MARK AS SHOWN.

FOR PROVIDING A WEB SITE FEATURING INFORMATION AND CONTENT PROMOTING PUBLIC AWARENESS OF THE NEED FOR PATRIOTISM AND A CITIZEN'S RESPONSIBILITY TO THE UNITED STATES OF AMERICA BY PROVIDING INSPIRATIONAL AND MOTIVATIONAL MESSAGES (U.S. CLS. 100, 101 AND 102).

HANNO RITTNER, EXAMINING ATTORNEY

SN 85-154,563. TRE OLIVE, LLC, EAST LONGMEADOW, MA. FILED 10-18-2010.

## Tre Olive

THE MARK CONSISTS OF STANDARD CHARACTERS WITHOUT CLAIM TO ANY PARTICULAR FONT, STYLE, SIZE, OR COLOR.

NO CLAIM IS MADE TO THE EXCLUSIVE RIGHT TO USE "OLIVE", APART FROM THE MARK AS SHOWN.

THE ENGLISH TRANSLATION OF "TRE" IN THE MARK IS "THREE"

FOR RETAIL STORE SERVICES FEATURING OLIVE OIL HARVESTED FROM OLIVE TREES RESERVED BY THE CUSTOMERS (U.S. CLS. 100, 101 AND 102).

FIRST USE 1-1-2010; IN COMMERCE 1-1-2010.

ANGELA DUONG, EXAMINING ATTORNEY



**CLASS 35—(Continued).**

SN 85-154,778. HOSPITALITYLANE.COM, BEAUMONT, CA. FILED 10-18-2010.

**CLASS 35—(Continued).**

SN 85-154,968. DESKTOP ACQUISITION SUB, INC., NEW YORK, NY. FILED 10-18-2010.



THE MARK CONSISTS OF A SILHOUETTE OF A COUPLE DANCING ON A WAITER'S TRAY WITH THE MOON AND STARS DIRECTLY IN THE BACKGROUND WITH A WAITER'S HAND HOLDING IT FROM BELOW WITH A TOWEL HANGING FROM THE WRIST AND THE WORDING "HOSPITALITYLANE.COM" ARCHED IN A HALF CIRCLE AROUND THE TOP OF THE DESIGN.

FOR ON-LINE ADVERTISING AND MARKETING SERVICES; PROMOTING THE GOODS AND SERVICES OF OTHERS BY PROVIDING A WEB SITE AT WHICH USERS CAN LINK TO ONLINE VENDORS (U.S. CLS. 100, 101 AND 102).

FIRST USE 4-15-2010; IN COMMERCE 4-15-2010.  
MICHAEL WEBSTER, EXAMINING ATTORNEY



THE COLOR(S) GREEN, YELLOW, BLUE, LIGHT BLUE, RED, PINK, PURPLE, GREY AND BLACK IS/ARE CLAIMED AS A FEATURE OF THE MARK.

THE MARK CONSISTS OF A GENERALLY SPHERICAL GEOMETRIC DESIGN COMPRISED OF INTERSECTING AND OVERLAPPING DIAGONAL, VERTICAL AND HORIZONTAL GREEN, YELLOW, BLUE, LIGHT BLUE, RED, PINK, PURPLE AND GREY LINES OVER A BLACK BACKGROUND.

FOR ADVERTISING, ADVERTISEMENT, MARKETING AND PROMOTION SERVICES; ON-LINE ADVERTISING, ADVERTISEMENT, MARKETING AND PROMOTION SERVICES; ADVERTISING, ADVERTISEMENT, MARKETING AND PROMOTION CONSULTATION SERVICES; DIGITAL-OUT-OF-HOME ADVERTISING, MARKETING, PROMOTION AND CONSULTATION SERVICES; PROMOTING THE GOODS AND SERVICES OF OTHERS VIA THE INTERNET THROUGH ADVERTISING, MARKETING AND PROMOTION SERVICES; MARKET RESEARCH, ANALYSIS, REPORTING AND MARKET INTELLIGENCE SERVICES; ADVERTISING SERVICES, NAMELY, ADVERTISING FOR OTHERS VIA THE INTERNET UTILIZING BANNERS AND BUTTONS, SKYSCRAPERS, POP-UPS, RICH MEDIA, DIRECT EMAIL MARKETING, VIRAL MARKETING, AFFILIATE MARKETING, SEARCH ENGINE OPTIMIZATION, AND ON AND OFF-LINE INTEGRATION AND REPORTING THAT PROVIDES REAL TIME OPTIMIZATION OF MARKETING CAMPAIGNS; BUSINESS SERVICES, NAMELY, CONDUCTING MARKETING RESEARCH TO EVALUATE EFFECTIVENESS OF VARIOUS APPLIED ONLINE ADVERTISING MEDIUMS AND SUPPORTING AD-SERVING TECHNOLOGIES UTILIZING THE INTERNET; BUSINESS MARKETING AND MANAGEMENT CONSULTATION SERVICES, NAMELY, PROVIDING DATABASE LIST MANAGEMENT, TARGETED MARKETING, PERFORMANCE-BASED AND DIRECT RESPONSE MARKETING, MARKETING ANALYSIS AND REPORTING, INTERACTIVE AND CONTEXTUAL ADVERTISING AND MEDIA PLANNING FOR OTHERS; PROMOTING THE GOODS AND SERVICES OF OTHERS VIA THE INTERNET THROUGH THE DISTRIBUTION OF ON-LINE MATERIALS, PROMOTIONAL CONTESTS AND SWEEPSTAKES; ADVERTISING, RICH-MEDIA ADVERTISING, MARKETING AND PROMOTION SERVICES; DISSEMINATION OF ADVERTISING FOR OTHERS VIA THE INTERNET AD-SERVING, TRACKING AND REPORTING SERVICES FOR ADVERTISERS AND PUBLISHERS (U.S. CLS. 100, 101 AND 102).

FIRST USE 9-8-2010; IN COMMERCE 9-8-2010.  
JUDITH HELFMAN, EXAMINING ATTORNEY

**CLASS 35—(Continued).**

SN 85-155,025. DESKTOP ACQUISITION SUB, INC., NEW YORK, NY. FILED 10-18-2010.



THE MARK CONSISTS OF A GENERALLY SPHERICAL GEOMETRIC DESIGN COMPRISED OF INTERSECTING AND OVERLAPPING DIAGONAL, VERTICAL AND HORIZONTAL LINES

FOR ADVERTISING, ADVERTISEMENT, MARKETING AND PROMOTION SERVICES; ON-LINE ADVERTISING, ADVERTISEMENT, MARKETING AND PROMOTION SERVICES; ADVERTISING, ADVERTISEMENT, MARKETING AND PROMOTION CONSULTATION SERVICES; DIGITAL-OUT-OF-HOME ADVERTISING, MARKETING, PROMOTION AND CONSULTATION SERVICES; PROMOTING THE GOODS AND SERVICES OF OTHERS VIA THE INTERNET THROUGH ADVERTISING, MARKETING AND PROMOTION SERVICES; MARKET RESEARCH, ANALYSIS, REPORTING AND MARKET INTELLIGENCE SERVICES; ADVERTISING SERVICES, NAMELY, ADVERTISING FOR OTHERS VIA THE INTERNET UTILIZING BANNERS AND BUTTONS, SKYSCRAPERS, POP-UPS, RICH MEDIA, DIRECT EMAIL MARKETING, VIRAL MARKETING, AFFILIATE MARKETING, SEARCH ENGINE OPTIMIZATION, AND ON AND OFF-LINE INTEGRATION AND REPORTING THAT PROVIDES REAL TIME OPTIMIZATION OF MARKETING CAMPAIGNS; BUSINESS SERVICES, NAMELY, CONDUCTING MARKETING RESEARCH TO EVALUATE EFFECTIVENESS OF VARIOUS APPLIED ONLINE ADVERTISING MEDIUMS AND SUPPORTING AD-SERVING TECHNOLOGIES UTILIZING THE INTERNET; BUSINESS MARKETING AND MANAGEMENT CONSULTATION SERVICES, NAMELY, PROVIDING DATABASE LIST MANAGEMENT, TARGETED MARKETING, PERFORMANCE-BASED AND DIRECT RESPONSE MARKETING, MARKETING ANALYSIS AND REPORTING, INTERACTIVE AND CONTEXTUAL ADVERTISING AND MEDIA PLANNING FOR OTHERS; PROMOTING THE GOODS AND SERVICES OF OTHERS VIA THE INTERNET THROUGH THE DISTRIBUTION OF ON-LINE MATERIALS, PROMOTIONAL CONTESTS AND SWEEPSTAKES; ADVERTISING, RICH-MEDIA ADVERTISING, MARKETING AND PROMOTION SERVICES; DISSEMINATION OF ADVERTISING FOR OTHERS VIA THE INTERNET AD-SERVING, TRACKING AND REPORTING SERVICES FOR ADVERTISERS AND PUBLISHERS (U.S. CLS. 100, 101 AND 102).

FIRST USE 9-8-2010; IN COMMERCE 9-8-2010.

JUDITH HELFMAN, EXAMINING ATTORNEY

**CLASS 35—(Continued).**

SN 85-155,094. GAIL'S ANGELS FOUNDATION, INC., NUTLEY, NJ. FILED 10-18-2010.



THE COLOR(S) PINK, WHITE, GRAY AND BLACK IS/ ARE CLAIMED AS A FEATURE OF THE MARK.

THE MARK CONSISTS OF WHITE AND GRAY WINGS, WITH A PINK RIBBON. "GAIL'S ANGELS" TEXT IS IN BLACK AND "WINGS OF HOPE" TEXT IS IN GRAY.

FOR CHARITABLE SERVICES, NAMELY, COORDINATION OF NON-MONETARY CONTRIBUTIONS TO CHARITIES AND NON-PROFITS (U.S. CLS. 100, 101 AND 102).

FIRST USE 1-1-2007; IN COMMERCE 1-1-2007.

EDWARD NELSON, EXAMINING ATTORNEY

SN 85-155,140. GAIL'S ANGELS FOUNDATION, INC., NUTLEY, NJ. FILED 10-18-2010.

## Gail's Angels, Wings of Hope

THE MARK CONSISTS OF STANDARD CHARACTERS WITHOUT CLAIM TO ANY PARTICULAR FONT, STYLE, SIZE, OR COLOR.

FOR CHARITABLE SERVICES, NAMELY, COORDINATION OF NON-MONETARY CONTRIBUTIONS TO CHARITIES AND NON-PROFITS (U.S. CLS. 100, 101 AND 102).

FIRST USE 1-1-2007; IN COMMERCE 1-1-2007.

EDWARD NELSON, EXAMINING ATTORNEY

SN 85-155,220. RAILING DYNAMICS, INC., EGG HARBOR TOWNSHIP, NJ. FILED 10-18-2010.

## BUILDERS RESERVE

THE MARK CONSISTS OF STANDARD CHARACTERS WITHOUT CLAIM TO ANY PARTICULAR FONT, STYLE, SIZE, OR COLOR.

NO CLAIM IS MADE TO THE EXCLUSIVE RIGHT TO USE "BUILDERS", APART FROM THE MARK AS SHOWN.

FOR ON-LINE RETAIL STORE SERVICES FEATURING DECKING PRODUCTS AND RAILING PRODUCTS, NAMELY, HANDRAILS AND BANISTERS (U.S. CLS. 100, 101 AND 102).

EDWARD NELSON, EXAMINING ATTORNEY

**CLASS 35—(Continued).**

SN 85-155,379. PROCAPITAL, DBA ZOOYAN, NEWTOWN, PA. FILED 10-18-2010.



THE COLOR(S) BROWN AND PINK IS/ARE CLAIMED AS A FEATURE OF THE MARK.

THE MARK CONSISTS OF LINES AND GEOMETRIC SHAPES AND CIRCLES REPRESENTING HUMAN FIGURES FORMING A STYLIZED BAR CODE. THE GEOMETRIC PARTS OF THE FIGURES ARE IN BROWN AND THE CIRCLES ARE IN PINK. "ZOOYAN" IS IN THE COLOR BROWN AND "CLIQUE" IS IN THE COLOR PINK.

FOR PROMOTIONAL SERVICES, NAMELY, PROMOTING THE GOODS OF OTHERS BY MEANS OF PROVIDING ONLINE COUPONS (U.S. CLS. 100, 101 AND 102).  
EDWARD NELSON, EXAMINING ATTORNEY

**CLASS 35—(Continued).**

SN 85-155,811. SHINKUNAS & LINDGREN, P.C., HUNTSVILLE, AL. FILED 10-19-2010.



THE MARK CONSISTS OF THREE SQUARES, ONE ON TOP OF THE OTHER, THE TOP ONE HAVING A CROSS SHAPE IN THE MIDDLE, THE MIDDLE SQUARE HAVING THE SHAPE OF AN "X" WITH A CIRCLE BENEATH IT, AND THE BOTTOM SQUARE, HAVING A SMALL CIRCLE CENTERED IN THE TOP PORTION OF THE BOX.

FOR ACCOUNTING SERVICES; TAX AND TAXATION PLANNING, ADVICE, INFORMATION AND CONSULTANCY SERVICES; TAX PREPARATION; TAX FILING SERVICES (U.S. CLS. 100, 101 AND 102).  
ELLEN BURNS, EXAMINING ATTORNEY

SN 85-155,458. EVERLY, JAMES, DETROIT, MI. FILED 10-18-2010.



NO CLAIM IS MADE TO THE EXCLUSIVE RIGHT TO USE SEED, APART FROM THE MARK AS SHOWN.

THE MARK CONSISTS OF TWO LEAVES WITH A SMALL SOIL OR DIRT AND THE STYLIZED TEXT "SEED NEEDS".

FOR ON-LINE RETAIL STORE SERVICES FEATURING SEEDS, SEED PACKETS (U.S. CLS. 100, 101 AND 102).  
FIRST USE 10-15-2009; IN COMMERCE 10-15-2009.  
DOMINICK J. SALEMI, EXAMINING ATTORNEY

SN 85-155,965. JOSEPH D. LAUZEN, WARRENVILLE, IL. FILED 10-19-2010.



NO CLAIM IS MADE TO THE EXCLUSIVE RIGHT TO USE "ACCOUNTING" AND "COMPREHENSIVE ACCOUNTING SOLUTIONS", APART FROM THE MARK AS SHOWN.

THE COLOR(S) BLUE, GRAY AND WHITE IS/ARE CLAIMED AS A FEATURE OF THE MARK.

THE MARK CONSISTS OF WHITE GREEK LETTER LAMBDA IN A BLUE CIRCLE TO THE LEFT OF THE WORD "LAUZEN" IN BLUE AND "ACCOUNTING" IN GRAY OVER A GRAY LINE WITH THE WORDS "COMPREHENSIVE ACCOUNTING SOLUTIONS" IN GRAY LETTERS BELOW.

FOR ACCOUNTANCY SERVICES; ACCOUNTING SERVICES; ADMINISTRATIVE ACCOUNTING; BUSINESS INFORMATION AND ACCOUNTING ADVISORY SERVICES (U.S. CLS. 100, 101 AND 102).  
GRETTA YAO, EXAMINING ATTORNEY

**CLASS 35—(Continued).**

SN 85-156,061. WAYPOINT HEALTH CARE ADVISORS, FORT WORTH, TX. FILED 10-19-2010.



NO CLAIM IS MADE TO THE EXCLUSIVE RIGHT TO USE "HEALTH CARE ADVISORS", APART FROM THE MARK AS SHOWN.

THE COLOR(S) BLACK, AND BLUE IS/ARE CLAIMED AS A FEATURE OF THE MARK.

THE MARK CONSISTS OF THE WORDING "WAYPOINT" IN BLACK WITH THE WORDING "HEALTH CARE ADVISORS" BELOW IT IN BLACK WITH A BLACK HORIZONTAL LINE IN BETWEEN. THE "O" IN THE WORD "POINT" CONSISTS OF A DESIGN OF A BLACK GLOBE WITH BLACK LINES OF LATITUDE AND LONGITUDE AND A BLACK CROSS IN THE MIDDLE. THERE ARE EIGHT BLUE TRIANGULAR SHAPES SURROUNDING THE GLOBE DESIGN.

FOR CONSULTING IN THE FIELDS OF HEALTH-CARE OPERATIONS MANAGEMENT AND HOSPITAL OPERATIONS MANAGEMENT (U.S. CLS. 100, 101 AND 102).

FIRST USE 4-1-2010; IN COMMERCE 4-1-2010.  
LINDSEY RUBIN, EXAMINING ATTORNEY

SN 85-156,227. MAXPOINT INTERACTIVE, INC., CARY, NC. FILED 10-19-2010.

**DIGITAL ZIP**

THE MARK CONSISTS OF STANDARD CHARACTERS WITHOUT CLAIM TO ANY PARTICULAR FONT, STYLE, SIZE, OR COLOR.

NO CLAIM IS MADE TO THE EXCLUSIVE RIGHT TO USE "DIGITAL", APART FROM THE MARK AS SHOWN.

FOR ONLINE ADVERTISING SERVICES FOR OTHERS (U.S. CLS. 100, 101 AND 102).

KATHY DE JONGE, EXAMINING ATTORNEY

SN 85-156,258. THE TRUCK PATCH LLC, TA THE TRUCK PATCH NATURAL MARKET, MOUNTAIN HOME, AR. FILED 10-19-2010.

**THE TRUCK PATCH**

THE MARK CONSISTS OF STANDARD CHARACTERS WITHOUT CLAIM TO ANY PARTICULAR FONT, STYLE, SIZE, OR COLOR.

FOR RETAIL GROCERY STORES FEATURING NATURAL FOOD PRODUCTS (U.S. CLS. 100, 101 AND 102).

FIRST USE 1-2-2010; IN COMMERCE 6-1-2010.  
JAMES LOVELACE, EXAMINING ATTORNEY

**CLASS 35—(Continued).**

SN 85-156,262. MOTT, ERICK, PALO ALTO, CA. FILED 10-19-2010.

**CREATORBASE**

THE MARK CONSISTS OF STANDARD CHARACTERS WITHOUT CLAIM TO ANY PARTICULAR FONT, STYLE, SIZE, OR COLOR.

FOR BUSINESS COLLABORATION SERVICES, NAMELY, PROVIDING AN ON-LINE COMPUTER DATABASE FEATURING PROJECT WORK LISTINGS AND BUSINESS OPPORTUNITY LISTINGS THAT CONNECT SUBSCRIBERS AND USERS IN DIFFERENT INDUSTRIES AND DISCIPLINES TO NEW BUSINESS OPPORTUNITIES (U.S. CLS. 100, 101 AND 102).

FIRST USE 6-0-2000; IN COMMERCE 3-17-2001.  
JAMES LOVELACE, EXAMINING ATTORNEY

SN 85-156,463. BOURNE INC., NEW YORK, NY. FILED 10-19-2010.

**BOURNE**

THE MARK CONSISTS OF STANDARD CHARACTERS WITHOUT CLAIM TO ANY PARTICULAR FONT, STYLE, SIZE, OR COLOR.

FOR ADVERTISING AND PROMOTION SERVICES AND RELATED CONSULTING TO BUSINESSES USING EMAIL AND DIGITAL MEDIA DISTRIBUTION (U.S. CLS. 100, 101 AND 102).

FIRST USE 11-13-2009; IN COMMERCE 11-13-2009.  
IRA J. GOODSaid, EXAMINING ATTORNEY

SN 85-156,473. PETERSON SYSTEMS INTERNATIONAL, INC., DUARTE, CA. FILED 10-19-2010.

**ASK FOR THE ORIGINAL**

THE MARK CONSISTS OF STANDARD CHARACTERS WITHOUT CLAIM TO ANY PARTICULAR FONT, STYLE, SIZE, OR COLOR.

FOR RETAIL SERVICES THROUGH DIRECT SOLICITATION BY DISTRIBUTORS DIRECTED TO END-USERS FEATURING CABLE PROTECTORS; RETAIL STORE AND ON-LINE RETAIL STORE SERVICES FEATURING CABLE PROTECTORS (U.S. CLS. 100, 101 AND 102).

FIRST USE 10-16-2006; IN COMMERCE 10-16-2006.  
ERIN FALK, EXAMINING ATTORNEY

**CLASS 35—(Continued).**

SN 85-156,501. FEW RESOURCES, LONGMONT, CO. FILED 10-19-2010.



NO CLAIM IS MADE TO THE EXCLUSIVE RIGHT TO USE "FOOD", "ENERGY", "WATER", AND "RESOURCES", APART FROM THE MARK AS SHOWN.

THE MARK CONSISTS OF A CIRCLE WITH A PLANT INSIDE AND THE STYLIZED TEXT "F.E.W. FOOD ENERGY WATER RESOURCES".

FOR ON-LINE RETAIL STORE SERVICES FEATURING ENVIRONMENTALLY FRIENDLY GOODS, RAISED GARDEN BEDS, RAIN BARRELS, BEE HIVES AND MATERIALS, SOLAR LIGHTS (U.S. CLS. 100, 101 AND 102).

FIRST USE 3-6-2009; IN COMMERCE 3-30-2010.  
ALICE BENMAMAN, EXAMINING ATTORNEY

**CLASS 35—(Continued).**

SN 85-156,662. WILSON, JR., SIDNEY, JACKSON, TN. FILED 10-20-2010.



NO CLAIM IS MADE TO THE EXCLUSIVE RIGHT TO USE THE UNIVERSAL RECYCLING SYMBOL, APART FROM THE MARK AS SHOWN.

THE MARK CONSISTS OF A FANCIFUL LINE DRAWING OF A KANGAROO, WITH A RECYCLE SYMBOL IN THE BELLY PORTION WITH THE WORDING "GREEN-GOOROO" WRITTEN ACROSS THE TAIL.

FOR CONSULTING SERVICES PERTAINING TO PROMOTING PUBLIC AWARENESS OF PRESERVATION OF THE ENVIRONMENT AND NATURAL RESOURCES THROUGH RECYCLING (U.S. CLS. 100, 101 AND 102).

FIRST USE 8-4-2009; IN COMMERCE 8-4-2009.  
NICHOLAS COLEMAN, EXAMINING ATTORNEY

SN 85-156,541. JOBING.COM, LLC, PHOENIX, AZ. FILED 10-19-2010.

**JOB OF THE DAY**

THE MARK CONSISTS OF STANDARD CHARACTERS WITHOUT CLAIM TO ANY PARTICULAR FONT, STYLE, SIZE, OR COLOR.

NO CLAIM IS MADE TO THE EXCLUSIVE RIGHT TO USE "JOB", APART FROM THE MARK AS SHOWN.

FOR PROVIDING INFORMATION IN THE FIELD OF EMPLOYMENT, NAMELY, JOB POSTINGS (U.S. CLS. 100, 101 AND 102).

FIRST USE 1-1-2004; IN COMMERCE 1-1-2004.  
EMILY CHUO, EXAMINING ATTORNEY

SN 85-156,709. BI-LO, LLC, GREENVILLE, SC. FILED 10-20-2010.



OWNER OF U.S. REG. NOS. 1,880,217, 3,506,198 AND OTHERS.

THE MARK CONSISTS OF "BI-LO" WITH LEAF IN PLACE OF HYPHEN.

FOR RETAIL GROCERY STORES; RETAIL PHARMACY SERVICES (U.S. CLS. 100, 101 AND 102).

FIRST USE 6-9-2010; IN COMMERCE 6-9-2010.  
NAAKWAMA ANKRAH, EXAMINING ATTORNEY

SN 85-156,796. NEW YORK MEDIA LLC, NEW YORK, NY. FILED 10-20-2010.

**THE VULTURE NETWORK**

THE MARK CONSISTS OF STANDARD CHARACTERS WITHOUT CLAIM TO ANY PARTICULAR FONT, STYLE, SIZE, OR COLOR.

NO CLAIM IS MADE TO THE EXCLUSIVE RIGHT TO USE "NETWORK", APART FROM THE MARK AS SHOWN.

FOR ADVERTISING SERVICES (U.S. CLS. 100, 101 AND 102).

FIRST USE 3-3-2009; IN COMMERCE 3-3-2009.  
ALYSSA STEEL, EXAMINING ATTORNEY

**CLASS 35—(Continued).**

SN 85-156,906. COLUMBUS NETWORKS, LTD., DBA COLUMBUS NETWORKS, BRIDGETOWN, BARBADOS, FILED 10-20-2010.



THE MARK CONSISTS OF TWO STYLIZED LETTERS "C" SUPERPOSED IN A SHADED SPHERE. THE SECOND OVAL LINE IN THE SPHERE, REPRESENTING A LETTER "C", IS SLIGHTLY AHEAD AND SUPERPOSED WITH RESPECT TO THE FIRST LINE OR STYLIZED LETTER "C".

FOR TELECOMMUNICATIONS NETWORK MANAGEMENT SERVICES, NAMELY, THE OPERATION AND ADMINISTRATION OF TELECOMMUNICATION SYSTEMS AND NETWORKS FOR OTHERS (U.S. CLS. 100, 101 AND 102).

FIRST USE 3-1-2007; IN COMMERCE 3-1-2007.  
EDWARD FENNESSY, EXAMINING ATTORNEY

SN 85-156,914. QUARLES PETROLEUM, INC., FREDERICKSBURG, VA. FILED 10-20-2010.

# Q-STOP

THE MARK CONSISTS OF STANDARD CHARACTERS WITHOUT CLAIM TO ANY PARTICULAR FONT, STYLE, SIZE, OR COLOR.

FOR RETAIL CONVENIENCE STORE SERVICES FEATURING GROCERIES, SNACKS AND GASOLINE (U.S. CLS. 100, 101 AND 102).

LINDA LAVACHE, EXAMINING ATTORNEY

**CLASS 35—(Continued).**

SN 85-157,244. CUBACEL INC, MIRAMAR, FL. FILED 10-20-2010.

# CUBACEL

THE MARK CONSISTS OF STANDARD CHARACTERS WITHOUT CLAIM TO ANY PARTICULAR FONT, STYLE, SIZE, OR COLOR.

FOR RETAIL DISTRIBUTORSHIP SERVICES FEATURING CELLULAR PHONES AND PRE-PAID TELEPHONE CALLING CARDS (U.S. CLS. 100, 101 AND 102).  
FIRST USE 3-6-2007; IN COMMERCE 3-6-2007.

FLORENTINA BLANDU, EXAMINING ATTORNEY

SN 85-157,376. COSTUME SUPERCENTER LLC, SOUTH ORANGE, NJ. FILED 10-20-2010.

# ROMANCE EMPORIUM

THE MARK CONSISTS OF STANDARD CHARACTERS WITHOUT CLAIM TO ANY PARTICULAR FONT, STYLE, SIZE, OR COLOR.

NO CLAIM IS MADE TO THE EXCLUSIVE RIGHT TO USE "EMPORIUM", APART FROM THE MARK AS SHOWN.

FOR RETAIL STORE AND ON-LINE RETAIL STORE SERVICES FEATURING LINGERIE, ADULT PRODUCTS, SEX TOYS, AND ADULT COSTUMES (U.S. CLS. 100, 101 AND 102).

PATRICIA EVANKO, EXAMINING ATTORNEY

SN 85-157,501. HARVEST FRESH INTERNATIONAL, BAKERSFIELD, CA. FILED 10-20-2010.

# Harvest Fresh International

THE MARK CONSISTS OF STANDARD CHARACTERS WITHOUT CLAIM TO ANY PARTICULAR FONT, STYLE, SIZE, OR COLOR.

NO CLAIM IS MADE TO THE EXCLUSIVE RIGHT TO USE "FRESH" AND "INTERNATIONAL", APART FROM THE MARK AS SHOWN.

FOR DISTRIBUTORSHIP SERVICES IN THE FIELD OF WHOLESALE FRESH FRUITS AND VEGETABLES (U.S. CLS. 100, 101 AND 102).

FIRST USE 6-5-2000; IN COMMERCE 6-5-2000.

JOHN WILKE, EXAMINING ATTORNEY

**CLASS 35—(Continued).**

SN 85-157,681. LA FRIEDA MEATS, INC., NORTH BERGEN, NJ. FILED 10-21-2010.

PAT LA FRIEDA SAYS EAT MY  
MEAT

THE MARK CONSISTS OF STANDARD CHARACTERS WITHOUT CLAIM TO ANY PARTICULAR FONT, STYLE, SIZE, OR COLOR.

THE NAME "PAT LA FRIEDA" IDENTIFIES A LIVING INDIVIDUAL WHOSE CONSENT IS OF RECORD.

FOR WHOLESALE DISTRIBUTORSHIPS FEATURING MEAT (U.S. CLS. 100, 101 AND 102).

FIRST USE 0-0-1979; IN COMMERCE 0-0-1979.

ANDREA HACK, EXAMINING ATTORNEY

---

SN 85-157,829. BIKE PATH COUNTRY, INC., YORKTOWN HEIGHTS, NY. FILED 10-21-2010.

BIKE PATH COUNTRY

THE MARK CONSISTS OF STANDARD CHARACTERS WITHOUT CLAIM TO ANY PARTICULAR FONT, STYLE, SIZE, OR COLOR.

NO CLAIM IS MADE TO THE EXCLUSIVE RIGHT TO USE "BIKE PATH", APART FROM THE MARK AS SHOWN.

FOR PROVIDING ADVERTISING SPACE ON OUTDOOR BILLBOARDS AND IN KIOSKS LOCATED ON BIKE PATHS AND WALKWAYS; PROVIDING ADVERTISING, MARKETING AND PROMOTIONAL SERVICES, NAMELY, DEVELOPMENT OF ADVERTISING CAMPAIGNS FOR OUTDOOR BILLBOARDS AND IN KIOSKS LOCATED ON BIKE PATHS AND WALKWAYS (U.S. CLS. 100, 101 AND 102).

BERYL GARDNER, EXAMINING ATTORNEY

---

SN 85-157,932. NEW YORK PUBLIC RADIO, NEW YORK, NY. FILED 10-21-2010.

IT'S A FREE COUNTRY

THE MARK CONSISTS OF STANDARD CHARACTERS WITHOUT CLAIM TO ANY PARTICULAR FONT, STYLE, SIZE, OR COLOR.

FOR PROVIDING AN INTERNET WEBSITE FEATURING NEWS AND INFORMATION, AND COMMENTARY IN THE FIELD OF REGIONAL, NATIONAL AND INTERNATIONAL POLITICS (U.S. CLS. 100, 101 AND 102).

FIRST USE 9-7-2010; IN COMMERCE 9-7-2010.

DAWN FELDMAN, EXAMINING ATTORNEY

**CLASS 35—(Continued).**

SN 85-158,275. BETTER BY THE BAY, INC., GREEN BAY, WI. FILED 10-21-2010.

WARMEST PLACE ON EARTH

THE MARK CONSISTS OF STANDARD CHARACTERS WITHOUT CLAIM TO ANY PARTICULAR FONT, STYLE, SIZE, OR COLOR.

OWNER OF U.S. REG. NO. 3,799,079.

FOR PROMOTING THE ECONOMIC DEVELOPMENT IN THE GREATER GREEN BAY, WISCONSIN AREA; PROMOTING TOURISM IN GREATER GREEN BAY, WISCONSIN AREA AREA (U.S. CLS. 100, 101 AND 102).

FIRST USE 4-1-2009; IN COMMERCE 4-1-2009.

DOMINICK J. SALEMI, EXAMINING ATTORNEY

---

SN 85-158,622. JCC ASSOCIATION OF NORTH AMERICA, NEW YORK, NY. FILED 10-21-2010.

DISCOVER @ THE JCC

THE MARK CONSISTS OF STANDARD CHARACTERS WITHOUT CLAIM TO ANY PARTICULAR FONT, STYLE, SIZE, OR COLOR.

OWNER OF U.S. REG. NOS. 2,331,171, 3,268,877 AND OTHERS.

FOR ASSOCIATION SERVICES, NAMELY, PROMOTING THE INTERESTS OF THE JEWISH COMMUNITY THROUGH CULTURAL, EDUCATIONAL, ATHLETIC, FITNESS, FINANCIAL, COMMUNITY, AND ENTERTAINMENT ACTIVITIES (U.S. CLS. 100, 101 AND 102).

DAVID I, EXAMINING ATTORNEY

**CLASS 35—(Continued).**

SN 85-158,625. JCC ASSOCIATION OF NORTH AMERICA, NEW YORK, NY. FILED 10-21-2010.



THE MARK CONSISTS OF DESIGN OF A SUN WITH THE TERM "DISCOVER" BELOW IT.

FOR ASSOCIATION SERVICES, NAMELY, PROMOTING THE INTERESTS OF THE JEWISH COMMUNITY THROUGH CULTURAL, EDUCATIONAL, ATHLETIC, FITNESS, FINANCIAL, COMMUNITY, AND ENTERTAINMENT ACTIVITIES (U.S. CLS. 100, 101 AND 102).

DAVID I, EXAMINING ATTORNEY

SN 85-158,729. BETTY'S PIES HOLDINGS, LLC, TWO HARBORS, MN. FILED 10-22-2010.

## BETTY'S PIES

THE MARK CONSISTS OF STANDARD CHARACTERS WITHOUT CLAIM TO ANY PARTICULAR FONT, STYLE, SIZE, OR COLOR.

NO CLAIM IS MADE TO THE EXCLUSIVE RIGHT TO USE "PIES", APART FROM THE MARK AS SHOWN.

THE NAME(S), PORTRAIT(S), AND/OR SIGNATURE(S) SHOWN IN THE MARK IDENTIFIES "BETTY" LESSARD, WHOSE CONSENT(S) TO REGISTER IS MADE OF RECORD.

FOR ON-LINE ORDERING SERVICES FEATURING PIES, BAKED GOODS, GIFT ITEMS, NOVELTY ITEMS (U.S. CLS. 100, 101 AND 102).

FIRST USE 6-1-2002; IN COMMERCE 6-1-2002.

ALICE BENMAMAN, EXAMINING ATTORNEY

**CLASS 35—(Continued).**

SN 85-158,818. CERTIFIED COLLEGE PLANNERS LLC, DBA RELAX TAX, SOMERVILLE, NJ. FILED 10-22-2010.

## AFFORDABLE PEACE OF MIND

THE MARK CONSISTS OF STANDARD CHARACTERS WITHOUT CLAIM TO ANY PARTICULAR FONT, STYLE, SIZE, OR COLOR.

FOR TAX FILING SERVICES; TAX PREPARATION (U.S. CLS. 100, 101 AND 102).

FIRST USE 10-15-2010; IN COMMERCE 10-15-2010.

JAY BESCH, EXAMINING ATTORNEY

SN 85-158,892. MJM SELLING, WINDERMERE, FL. FILED 10-22-2010.

## Zentila

THE MARK CONSISTS OF STANDARD CHARACTERS WITHOUT CLAIM TO ANY PARTICULAR FONT, STYLE, SIZE, OR COLOR.

THE WORDING "ZENTILA" HAS NO MEANING IN A FOREIGN LANGUAGE.

FOR PROVIDING AN ONLINE BUSINESS DIRECTORY FEATURING HOTELS PROVIDING DISCOUNT PACKAGES FOR GROUPS (U.S. CLS. 100, 101 AND 102).

ERNEST SHOSHO, EXAMINING ATTORNEY

SN 85-160,492. TAXPAYER ALLIANCE SERVICES, LLC., DBA 123TAXCREDIT.COM, POMPANO BEACH, FL. FILED 10-25-2010.

## 123taxcredit.com

THE COLOR(S) BLUE AND RED IS/ARE CLAIMED AS A FEATURE OF THE MARK.

THE MARK CONSISTS OF THE STYLIZED TEXT "123TAXCREDIT.COM". THE NUMBERS "123" AND THE TERMS "CREDIT" AND "COM" APPEAR IN THE COLOR BLUE. THE WORD "TAX" AND THE "." APPEAR IN THE COLOR RED.

FOR INCOME TAX CONSULTATION; INCOME TAX PREPARATION; MANAGEMENT OF TAX FILES; TAX AND TAXATION PLANNING, ADVICE, INFORMATION AND CONSULTANCY SERVICES; TAX CONSULTATION; TAX FILING SERVICES; TAX PREPARATION (U.S. CLS. 100, 101 AND 102).

FIRST USE 1-5-2010; IN COMMERCE 3-1-2010.

GEOFFREY FOSDICK, EXAMINING ATTORNEY



**CLASS 35—(Continued).**

SN 85-161,513. CF FOODS LLC, NEW BRITAIN, CT. FILED 10-26-2010.



THE COLOR(S) BLUE, LIGHT BLUE, GRAY AND WHITE IS/ARE CLAIMED AS A FEATURE OF THE MARK.

THE MARK CONSISTS OF THE LETTER "C" IN BLUE TOPPED WITH WHIPPED CREAM IN GRAY AND WHITE AND A LIGHT BLUE SPOON.

FOR DISTRIBUTORSHIP SERVICES FEATURING FROZEN DESSERTS (U.S. CLS. 100, 101 AND 102).

TRACY WHITTAKER-BROWN, EXAMINING ATTORNEY

SN 85-162,978. SOCIAL FINGERPRINT, LLC, WESTPORT, CT. FILED 10-27-2010.



NO CLAIM IS MADE TO THE EXCLUSIVE RIGHT TO USE "SOCIAL", APART FROM THE MARK AS SHOWN.

FOR BUSINESS CONSULTING SERVICES RELATING TO PRODUCT DISTRIBUTION, OPERATIONS MANAGEMENT SERVICES, LOGISTICS, REVERSE LOGISTICS, SUPPLY CHAIN, AND PRODUCTION SYSTEMS AND DISTRIBUTION SOLUTIONS; BUSINESS EVALUATION SERVICES IN THE FIELD OF CORPORATE SOCIAL RESPONSIBILITY (U.S. CLS. 100, 101 AND 102).

FIRST USE 10-15-2009; IN COMMERCE 6-1-2010.  
CHRISTINE COOPER, EXAMINING ATTORNEY

**CLASS 35—(Continued).**

SN 85-163,325. THE 500 STAFFING INC., OAKVILLE, ONTARIO, CANADA, FILED 10-28-2010.



PRIORITY CLAIMED UNDER SEC. 44(D) ON CANADA APPLICATION NO. 1500362, FILED 10-20-2010.

THE MARK CONSISTS OF THE NUMBER "500" INSIDE A DARK CIRCLE.

FOR PROVIDING TEMPORARY AND FULL-TIME PERSONNEL; EXECUTIVE AND PROFESSIONAL SEARCH AND PLACEMENT SERVICES; JOB PLACEMENT SERVICES (U.S. CLS. 100, 101 AND 102).

ANDREA HACK, EXAMINING ATTORNEY

SN 85-164,850. SECRETARY OF STATE, STATE OF LOUISIANA, BATON ROUGE, LA. FILED 10-29-2010.



THE COLOR(S) GREEN, GOLD, PURPLE AND BLACK IS/ARE CLAIMED AS A FEATURE OF THE MARK.

THE MARK CONSISTS OF "WWW." IN BLACK, "GEAUX" IN GOLD, "BIZ" IN PURPLE AND ".COM" IN BLACK SUPERIMPOSED OVER A DEPICTION OF A METROPOLITAN SKYLINE IN GREEN.

FOR BUSINESS INFORMATION SERVICES, NAMELY, INFORMATION ON STARTING A BUSINESS, INCLUDING GOVERNMENT LICENSES AND PERMITS (U.S. CLS. 100, 101 AND 102).

FIRST USE 7-1-2007; IN COMMERCE 7-1-2007.  
SKYE YOUNG, EXAMINING ATTORNEY

SN 85-167,052. ZERO ALPHA GROUP, LLC, TOWN AND COUNTRY, MO. FILED 11-2-2010.

**ACTIVE OVERSIGHT /  
PROACTIVE ADVICE**

THE MARK CONSISTS OF STANDARD CHARACTERS WITHOUT CLAIM TO ANY PARTICULAR FONT, STYLE, SIZE, OR COLOR.

NO CLAIM IS MADE TO THE EXCLUSIVE RIGHT TO USE "ACTIVE OVERSIGHT" AND "ADVICE", APART FROM THE MARK AS SHOWN.

FOR TRADE ASSOCIATION SERVICES, NAMELY, PROMOTING THE INTERESTS OF INDEPENDENT FINANCIAL ADVISORS (U.S. CLS. 100, 101 AND 102).

KELLY CHOE, EXAMINING ATTORNEY

**CLASS 35—(Continued).**

SN 85-168,378. FIVERR INTERNATIONAL LTD., BINYAMINA, ISRAEL, FILED 11-3-2010.

# FIVERR

THE MARK CONSISTS OF STANDARD CHARACTERS WITHOUT CLAIM TO ANY PARTICULAR FONT, STYLE, SIZE, OR COLOR.

FOR OPERATING ON-LINE MARKETPLACES FOR SELLERS OF GOODS AND/OR SERVICES (U.S. CLS. 100, 101 AND 102).

FIRST USE 2-17-2010; IN COMMERCE 2-17-2010.  
GIANCARLO CASTRO, EXAMINING ATTORNEY

**CLASS 35—(Continued).**

SN 85-170,327. EQUINOX HOLDINGS, INC., NEW YORK, NY, FILED 11-5-2010.

## IT'S NOT FITNESS. IT'S LIFE.

THE MARK CONSISTS OF STANDARD CHARACTERS WITHOUT CLAIM TO ANY PARTICULAR FONT, STYLE, SIZE, OR COLOR.

OWNER OF U.S. REG. NOS. 3,153,005 AND 3,384,480.

FOR ON-LINE RETAIL STORE SERVICES FEATURING A WIDE RANGE OF CONSUMER GOODS SUCH AS FITNESS APPAREL, SWIMWEAR, SWIM ACCESSORIES, YOGA ACCESSORIES, MUSIC, AUDIO BOOKS, MAGAZINES, JOURNALS, BOOKS, MP3 PLAYERS, HEADPHONES, ALL PURPOSE ATHLETIC BAGS, BACKPACKS, FOOTWEAR, HATS, HAIR BANDS, BELTS, GLOVES, JEWELRY, HEART RATE MONITORS, COSMETICS, HOME GOODS, LIGHTING FIXTURES, GARDEN GOODS, KITCHEN PRODUCTS, DISHES, GLASSES, TABLEWARE, FURNITURE, TRAVEL PRODUCTS, SCENTED CANDLES, KEY LOCKS, VITAMIN AND NUTRITIONAL SUPPLEMENTS, FLOOR COVERINGS, EXERCISE EQUIPMENT; RETAIL STORE SERVICES FEATURING A WIDE RANGE OF CONSUMER GOODS (U.S. CLS. 100, 101 AND 102).

KIM SAITO, EXAMINING ATTORNEY

SN 85-170,530. CAPAS, AUDRA, DBA 5STARPR, LLC, OAK HILL, VA, FILED 11-5-2010.

# 5StarPR

THE MARK CONSISTS OF STANDARD CHARACTERS WITHOUT CLAIM TO ANY PARTICULAR FONT, STYLE, SIZE, OR COLOR.

FOR ADVERTISING AND BUSINESS SERVICES, NAMELY, SECURING AIRTIME ON ALL FORMS OF MEDIA COMMUNICATIONS STATIONS, SYSTEMS, NETWORKS, AND SERVICES FOR THE PURPOSE OF PROMOTING THE GOODS AND SERVICES OF OTHERS; ADVERTISING AND MARKETING CONSULTANCY; ADVERTISING AND MARKETING SERVICES PROVIDED BY MEANS OF INDIRECT METHODS OF MARKETING COMMUNICATIONS, NAMELY, SOCIAL MEDIA, SEARCH ENGINE MARKETING, INQUIRY MARKETING, INTERNET MARKETING, MOBILE MARKETING, BLOGGING AND OTHER FORMS OF PASSIVE, SHARABLE OR VIRAL COMMUNICATIONS CHANNELS; ADVERTISING BY TRANSMISSION OF ON-LINE PUBLICITY FOR THIRD PARTIES THROUGH ELECTRONIC COMMUNICATIONS NETWORKS; ADVERTISING SERVICES, NAMELY, PROMOTING AND MARKETING THE GOODS AND SERVICES OF OTHERS THROUGH ALL PUBLIC COMMUNICATION MEANS; ADVERTISING SERVICES, PUBLIC RELATIONS AND MARKETING SERVICES, NAMELY, PROMOTING AND MARKETING THE GOODS AND SERVICES OF OTHERS THROUGH ALL PUBLIC COMMUNICATION MEANS; ADVERTISING THROUGH ALL PUBLIC COMMUNICATION MEANS; ADVERTISING, MARKETING AND PROMOTION SERVICES (U.S. CLS. 100, 101 AND 102).

FIRST USE 12-31-1999; IN COMMERCE 1-1-2000.

RICHARD WHITE, EXAMINING ATTORNEY

SN 85-170,210. NEWMARKET IMPRESSIONS, LLC, BEVERLY HILLS, CA, FILED 11-5-2010.

# My Fresh Egg

THE MARK CONSISTS OF STANDARD CHARACTERS WITHOUT CLAIM TO ANY PARTICULAR FONT, STYLE, SIZE, OR COLOR.

NO CLAIM IS MADE TO THE EXCLUSIVE RIGHT TO USE "FRESH EGG", APART FROM THE MARK AS SHOWN.

FOR TRACKING SERVICES TO CHECK WHERE EGGS ORIGINATED, WHEN THEY WERE LAID AND IF THERE ARE ANY RECALLS FOR BUSINESS PURPOSES (U.S. CLS. 100, 101 AND 102).

FIRST USE 9-0-2010; IN COMMERCE 9-0-2010.  
JENNY PARK, EXAMINING ATTORNEY

**CLASS 35—(Continued).**

SN 85-170,952. VIRENTEM VENTURES, LLC, LOS ALTOS, CA. FILED 11-7-2010.

**COTYLEDON**

THE MARK CONSISTS OF STANDARD CHARACTERS WITHOUT CLAIM TO ANY PARTICULAR FONT, STYLE, SIZE, OR COLOR.

FOR BUSINESS CONSULTING, MANAGEMENT, PLANNING, AND SUPERVISION SERVICES, BUSINESS DEVELOPMENT CONSULTING SERVICES, BUSINESS MANAGEMENT CONSULTING AND ADVISORY SERVICES AND BUSINESS INFORMATION CONSULTING SERVICES (U.S. CLS. 100, 101 AND 102).

ANNE MADDEN, EXAMINING ATTORNEY

SN 85-171,390. DESKTOP ACQUISITION SUB, INC., NEW YORK, NY. FILED 11-8-2010.

**WE FIND THE AWESOME IN  
CHAOS**

THE MARK CONSISTS OF STANDARD CHARACTERS WITHOUT CLAIM TO ANY PARTICULAR FONT, STYLE, SIZE, OR COLOR.

FOR ADVERTISING, ADVERTISEMENT, MARKETING AND PROMOTION SERVICES; ON-LINE ADVERTISING, ADVERTISEMENT, MARKETING AND PROMOTION SERVICES; ADVERTISING, ADVERTISEMENT, MARKETING AND PROMOTION CONSULTATION SERVICES; DIGITAL-OUT-OF-HOME ADVERTISING, MARKETING, PROMOTION AND CONSULTATION SERVICES; PROMOTING THE GOODS AND SERVICES OF OTHERS VIA THE INTERNET THROUGH ADVERTISING, MARKETING AND PROMOTION SERVICES; MARKET RESEARCH, ANALYSIS, REPORTING AND MARKET INTELLIGENCE SERVICES; ADVERTISING SERVICES, NAMELY, ADVERTISING FOR OTHERS VIA THE INTERNET UTILIZING BANNERS AND BUTTONS, SKYSCRAPERS, POP-UPS, RICH MEDIA, DIRECT E-MAIL MARKETING, VIRAL MARKETING, AFFILIATE MARKETING, SEARCH ENGINE OPTIMIZATION, AND ON AND OFF-LINE INTEGRATION AND REPORTING THAT PROVIDES REAL TIME OPTIMIZATION OF MARKETING CAMPAIGNS; BUSINESS SERVICES, NAMELY, CONDUCTING MARKETING RESEARCH TO EVALUATE EFFECTIVENESS OF VARIOUS APPLIED ONLINE ADVERTISING MEDIUMS AND SUPPORTING AD-SERVING TECHNOLOGIES UTILIZING THE INTERNET; BUSINESS MARKETING AND MANAGEMENT CONSULTATION SERVICES, NAMELY, PROVIDING DATABASE LIST MANAGEMENT, TARGETED MARKETING, PERFORMANCE-BASED AND DIRECT RESPONSE MARKETING, MARKETING ANALYSIS AND REPORTING, INTERACTIVE AND CONTEXTUAL ADVERTISING AND MEDIA PLANNING FOR OTHERS; PROMOTING THE GOODS AND SERVICES OF OTHERS VIA THE INTERNET THROUGH THE DISTRIBUTION OF ON-LINE MATERIALS, PROMOTIONAL CONTESTS AND SWEEPSTAKES; ADVERTISING, RICH-MEDIA ADVERTISING, MARKETING AND PROMOTION SERVICES; DISSEMINATION OF ADVERTISING FOR OTHERS VIA THE INTERNET AD-SERVING, TRACKING AND REPORTING SERVICES FOR ADVERTISERS AND PUBLISHERS (U.S. CLS. 100, 101 AND 102).

FIRST USE 9-30-2010; IN COMMERCE 9-30-2010.

JUDITH HELFMAN, EXAMINING ATTORNEY

**CLASS 35—(Continued).**

SN 85-171,645. FREKI CORPORATION N.V., DBA PINNACLE SPORTS WORLDWIDE, WILEMSTAD, CURACAO, NETHERLANDS ANTILLES, FILED 11-8-2010.

**PINNACLE SPORTS DIRECT**

THE MARK CONSISTS OF STANDARD CHARACTERS WITHOUT CLAIM TO ANY PARTICULAR FONT, STYLE, SIZE, OR COLOR.

NO CLAIM IS MADE TO THE EXCLUSIVE RIGHT TO USE "SPORTS", APART FROM THE MARK AS SHOWN.

FOR ADMINISTRATION OF A PROGRAM FOR ENABLING PARTICIPANTS TO OBTAIN DISCOUNTS ON PRODUCTS AND SERVICES; ADVERTISEMENT FOR OTHERS ON THE INTERNET; ADVERTISING AND COMMERCIAL INFORMATION SERVICES, VIA THE INTERNET; ADVERTISING AND DIRECTORY SERVICES, NAMELY, PROMOTING THE SERVICES OF OTHERS BY PROVIDING A WEB PAGE FEATURING LINKS TO THE WEBSITES OF OTHERS; ADVERTISING AND MARKETING SERVICES, NAMELY, PROMOTING THE GOODS AND SERVICES OF OTHERS; ADVERTISING AND PROMOTIONAL SERVICES; ADVERTISING AND PUBLICITY SERVICES; ADVERTISING AND PUBLICITY SERVICES, NAMELY, PROMOTING THE GOODS, SERVICES, BRAND IDENTITY AND COMMERCIAL INFORMATION AND NEWS OF THIRD PARTIES THROUGH PRINT, AUDIO, VIDEO, DIGITAL AND ON-LINE MEDIUM; ADVERTISING BY TRANSMISSION OF ON-LINE PUBLICITY FOR THIRD PARTIES THROUGH ELECTRONIC COMMUNICATIONS NETWORKS; ADVERTISING ON THE INTERNET FOR OTHERS; ADVERTISING SERVICES; ADVERTISING SERVICES, NAMELY, PROMOTING THE BRANDS, GOODS AND SERVICES OF OTHERS; ADVERTISING THE SERVICES OF OTHERS VIA WEB PAGES OPTIMIZED FOR ON-LINE SEARCH ENGINES; ADVERTISING, INCLUDING ON-LINE ADVERTISING ON A COMPUTER NETWORK; ADVERTISING, INCLUDING PROMOTION RELATING TO THE SALE OF ARTICLES AND SERVICES FOR THIRD PARTIES BY THE TRANSMISSION OF ADVERTISING MATERIAL AND THE DISSEMINATION OF ADVERTISING MESSAGES ON COMPUTER NETWORKS; ADVERTISING, PROMOTION AND MARKETING SERVICES IN THE NATURE OF E-MAIL BLAST CAMPAIGNS FOR OTHERS; CONTESTS AND INCENTIVE AWARD PROGRAMS TO PROMOTE THE SALE OF PRODUCTS AND SERVICES OF OTHERS; COOPERATIVE ADVERTISING AND MARKETING SERVICES BY WAY OF SOLICITATION, CUSTOMER SERVICE AND PROVIDING MARKETING INFORMATION VIA WEB SITES ON A GLOBAL COMPUTER NETWORK; CUSTOMER LOYALTY SERVICES AND CUSTOMER CLUB SERVICES, FOR COMMERCIAL, PROMOTIONAL AND/OR ADVERTISING PURPOSES; CUSTOMER SERVICE MANAGEMENT FOR OTHERS; CUSTOMER SERVICES, NAMELY, PROVIDING CUSTOMER SERVICE AND PRODUCT INQUIRY SERVICES VIA TELEPHONE AND E-MAIL FOR OTHERS; DISSEMINATION OF ADVERTISING FOR OTHERS VIA AN ON-LINE COMMUNICATIONS NETWORK ON THE INTERNET; DISSEMINATION OF ADVERTISING FOR OTHERS VIA PUBLIC AND PRIVATE WIRELESS NETWORKS FOR DISPLAY ON MOBILE DEVICES; GENERAL BUSINESS NETWORKING REFERRAL SERVICES, NAMELY, PROMOTING THE GOODS AND SERVICES OF OTHERS BY PASSING BUSINESS LEADS AND REFERRALS AMONG GROUP MEMBERS; ON-LINE ADVERTISING AND MARKETING SERVICES; ON-LINE ADVERTISING ON COMPUTER COMMUNICATION NETWORKS; ON-LINE ADVERTISING ON COMPUTER NETWORKS; ON-LINE ADVERTISING SERVICES FOR OTHERS; ON-LINE PROMOTION OF COMPUTER NETWORKS AND WEBSITES; ONLINE ADVERTISEMENTS; ONLINE ADVERTISING AND PROMOTIONAL SERVICES; ONLINE ADVERTISING VIA A COMPUTER COMMUNICATIONS NETWORK; ONLINE MEDIA MONITORING SERVICES USING COMPUTER SOFTWARE TO AUTOMATICALLY MONITOR INTERNET WEBSITES AND ONLINE PUB-

**CLASS 35—(Continued).**

LICATIONS FOR CUSTOMER-SPECIFIED TOPICS AND TO CAPTURE RELEVANT CONTENT ON THOSE TOPICS, AND PROVIDING DOCUMENTATION AND ANALYSIS OF THAT ONLINE CONTENT TO OTHERS FOR BUSINESS PURPOSES; PROMOTING THE GOODS AND SERVICES OF OTHERS BY MEANS OF DISTRIBUTING ADVERTISING ON THE INTERNET; PROMOTING THE GOODS AND SERVICES OF OTHERS BY MEANS OF THE ISSUANCE OF LOYALTY REWARDS CARDS; PROMOTING THE GOODS AND SERVICES OF OTHERS THROUGH SEARCH ENGINE REFERRAL TRAFFIC ANALYSIS AND REPORTING; PROMOTING, ADVERTISING AND MARKETING OF THE ON-LINE WEB SITES OF OTHERS; PROMOTION, ADVERTISING AND MARKETING OF ON-LINE WEBSITES; PROVIDING A WEB SITE WHICH FEATURES ADVERTISEMENTS FOR THE GOODS AND SERVICES OF OTHERS ON A GLOBAL COMPUTER NETWORK (U.S. CLS. 100, 101 AND 102).

FIRST USE 6-1-1998; IN COMMERCE 6-1-1998.  
JOHN HWANG, EXAMINING ATTORNEY

---

SN 85-171.659. FREKI CORPORATION N.V., DBA PINNACLE SPORTS WORLDWIDE, WILEMSTAD, CURACAO, NETHERLANDS ANTILLES, FILED 11-8-2010.

**PINNACLE SPORTS AFFILIATES**

THE MARK CONSISTS OF STANDARD CHARACTERS WITHOUT CLAIM TO ANY PARTICULAR FONT, STYLE, SIZE, OR COLOR.

NO CLAIM IS MADE TO THE EXCLUSIVE RIGHT TO USE "SPORTS AFFILIATES", APART FROM THE MARK AS SHOWN.

FOR ADMINISTRATION OF A PROGRAM FOR ENABLING PARTICIPANTS TO OBTAIN DISCOUNTS ON PRODUCTS AND SERVICES; ADVERTISEMENT FOR OTHERS ON THE INTERNET; ADVERTISING AND COMMERCIAL INFORMATION SERVICES, VIA THE INTERNET; ADVERTISING AND DIRECTORY SERVICES, NAMELY, PROMOTING THE SERVICES OF OTHERS BY PROVIDING A WEB PAGE FEATURING LINKS TO THE WEBSITES OF OTHERS; ADVERTISING AND MARKETING SERVICES, NAMELY, PROMOTING THE GOODS AND SERVICES OF OTHERS; ADVERTISING AND PROMOTIONAL SERVICES; ADVERTISING AND PUBLICITY SERVICES; ADVERTISING AND PUBLICITY SERVICES, NAMELY, PROMOTING THE GOODS, SERVICES, BRAND IDENTITY AND COMMERCIAL INFORMATION AND NEWS OF THIRD PARTIES THROUGH PRINT, AUDIO, VIDEO, DIGITAL AND ON-LINE MEDIUM; ADVERTISING BY TRANSMISSION OF ON-LINE PUBLICITY FOR THIRD PARTIES THROUGH ELECTRONIC COMMUNICATIONS NETWORKS; ADVERTISING ON THE INTERNET FOR OTHERS; ADVERTISING SERVICES; ADVERTISING SERVICES, NAMELY, PROMOTING THE BRANDS, GOODS AND SERVICES OF OTHERS; ADVERTISING THE SERVICES OF OTHERS VIA WEB PAGES OPTIMIZED FOR ON-LINE SEARCH ENGINES; ADVERTISING, INCLUDING ON-LINE ADVERTISING ON A COMPUTER NETWORK; ADVERTISING, INCLUDING PROMOTION RELATING TO THE SALE OF ARTICLES AND SERVICES FOR THIRD PARTIES BY THE TRANSMISSION OF ADVERTISING MATERIAL AND THE DISSEMINATION OF ADVERTISING MESSAGES ON COMPUTER NETWORKS; ADVERTISING, PROMOTION AND MARKETING SERVICES IN THE NATURE OF E-MAIL BLAST CAMPAIGNS FOR OTHERS; CONTESTS AND INCENTIVE AWARD PROGRAMS TO PROMOTE THE SALE OF PRODUCTS AND SERVICES OF OTHERS; COOPERATIVE ADVERTISING AND MARKETING SERVICES BY WAY OF SOLICITATION, CUSTOMER SERVICE AND PROVIDING MARKETING INFORMATION VIA WEB SITES ON A GLOBAL COMPUTER NETWORK; CUSTO-

**CLASS 35—(Continued).**

MER LOYALTY SERVICES AND CUSTOMER CLUB SERVICES, FOR COMMERCIAL, PROMOTIONAL AND/OR ADVERTISING PURPOSES; CUSTOMER SERVICE MANAGEMENT FOR OTHERS; CUSTOMER SERVICES, NAMELY, PROVIDING CUSTOMER SERVICE AND PRODUCT INQUIRY SERVICES VIA TELEPHONE AND E-MAIL FOR OTHERS; DISSEMINATION OF ADVERTISING FOR OTHERS VIA AN ON-LINE COMMUNICATIONS NETWORK ON THE INTERNET; DISSEMINATION OF ADVERTISING FOR OTHERS VIA PUBLIC AND PRIVATE WIRELESS NETWORKS FOR DISPLAY ON MOBILE DEVICES; GENERAL BUSINESS NETWORKING REFERRAL SERVICES, NAMELY, PROMOTING THE GOODS AND SERVICES OF OTHERS BY PASSING BUSINESS LEADS AND REFERRALS AMONG GROUP MEMBERS; ON-LINE ADVERTISING AND MARKETING SERVICES; ON-LINE ADVERTISING ON COMPUTER COMMUNICATION NETWORKS; ON-LINE ADVERTISING ON COMPUTER NETWORKS; ON-LINE ADVERTISING SERVICES FOR OTHERS; ON-LINE PROMOTION OF COMPUTER NETWORKS AND WEBSITES; ONLINE ADVERTISEMENTS; ONLINE ADVERTISING AND PROMOTIONAL SERVICES; ONLINE ADVERTISING VIA A COMPUTER COMMUNICATIONS NETWORK; ONLINE MEDIA MONITORING SERVICES USING COMPUTER SOFTWARE TO AUTOMATICALLY MONITOR INTERNET WEBSITES AND ONLINE PUBLICATIONS FOR CUSTOMER-SPECIFIED TOPICS AND TO CAPTURE RELEVANT CONTENT ON THOSE TOPICS, AND PROVIDING DOCUMENTATION AND ANALYSIS OF THAT ONLINE CONTENT TO OTHERS FOR BUSINESS PURPOSES; PROMOTING THE GOODS AND SERVICES OF OTHERS BY MEANS OF DISTRIBUTING ADVERTISING ON THE INTERNET; PROMOTING THE GOODS AND SERVICES OF OTHERS BY MEANS OF THE ISSUANCE OF LOYALTY REWARDS CARDS; PROMOTING THE GOODS AND SERVICES OF OTHERS THROUGH SEARCH ENGINE REFERRAL TRAFFIC ANALYSIS AND REPORTING; PROMOTING, ADVERTISING AND MARKETING OF THE ON-LINE WEB SITES OF OTHERS; PROMOTION, ADVERTISING AND MARKETING OF ON-LINE WEBSITES; PROVIDING A WEB SITE WHICH FEATURES ADVERTISEMENTS FOR THE GOODS AND SERVICES OF OTHERS ON A GLOBAL COMPUTER NETWORK (U.S. CLS. 100, 101 AND 102).

FIRST USE 6-1-1998; IN COMMERCE 6-1-1998.  
JOHN HWANG, EXAMINING ATTORNEY

---

SN 85-172.186. TENX ENERGY CORP., RALEIGH, NC. FILED 11-9-2010.

# TenX Box

THE MARK CONSISTS OF STANDARD CHARACTERS WITHOUT CLAIM TO ANY PARTICULAR FONT, STYLE, SIZE, OR COLOR.

FOR BUSINESS CONSULTING AND ADVISORY SERVICES IN THE FIELD OF ENERGY EFFICIENCY (U.S. CLS. 100, 101 AND 102).

LESLIE RICHARDS, EXAMINING ATTORNEY

**CLASS 35—(Continued).**

SN 85-172,579. VNC COMMUNICATIONS, INC., CHICAGO, IL. FILED 11-9-2010.

ASQ

THE MARK CONSISTS OF STANDARD CHARACTERS WITHOUT CLAIM TO ANY PARTICULAR FONT, STYLE, SIZE, OR COLOR.

FOR ADVERTISING SERVICES, NAMELY, PROVIDING AN ONLINE VIDEO ADVERTISING MODEL TO OTHERS (U.S. CLS. 100, 101 AND 102).

FIRST USE 9-15-2010; IN COMMERCE 9-15-2010.

KATHERINE M. DUBRAY, EXAMINING ATTORNEY

SN 85-172,590. VNC COMMUNICATIONS, INC., CHICAGO, IL. FILED 11-9-2010.



THE MARK CONSISTS OF CAPITALIZED LETTERS "AS" AND A LOWERCASE LETTER "Q" WITHIN A ROUNDED SQUARE WITH A WAVE DESIGN.

FOR ADVERTISING SERVICES, NAMELY, PROVIDING AN ONLINE VIDEO ADVERTISING MODEL TO OTHERS (U.S. CLS. 100, 101 AND 102).

FIRST USE 9-15-2010; IN COMMERCE 9-15-2010.

KATHERINE M. DUBRAY, EXAMINING ATTORNEY

SN 85-172,908. FLUENT, INC., NEW YORK, NY. FILED 11-9-2010.



THE MARK CONSISTS OF A SWIRL WITH THE STYLIZED TEXT "MOBFLOW".

FOR ADVERTISEMENT VIA MOBILE PHONE NETWORKS (U.S. CLS. 100, 101 AND 102).

FIRST USE 9-28-2010; IN COMMERCE 9-28-2010.

MICHAEL ENGEL, EXAMINING ATTORNEY

**CLASS 35—(Continued).**

SN 85-173,040. INNOVATIVE DIESEL PERFORMANCE, LLC, ELKTON, MD. FILED 11-9-2010.

Innovative Diesel

THE MARK CONSISTS OF STANDARD CHARACTERS WITHOUT CLAIM TO ANY PARTICULAR FONT, STYLE, SIZE, OR COLOR.

NO CLAIM IS MADE TO THE EXCLUSIVE RIGHT TO USE "DIESEL", APART FROM THE MARK AS SHOWN.

FOR ON-LINE RETAIL STORE SERVICES FEATURING DIESEL PERFORMANCE PARTS AND ACCESSORIES (U.S. CLS. 100, 101 AND 102).

FIRST USE 8-1-2004; IN COMMERCE 8-1-2004.

WENDY JUN, EXAMINING ATTORNEY

SN 85-173,225. MAZDA MOTOR OF AMERICA, INC., IRVINE, CA. FILED 11-10-2010.



OWNER OF U.S. REG. NOS. 2,987,176, 3,427,945 AND OTHERS.

NO CLAIM IS MADE TO THE EXCLUSIVE RIGHT TO USE "TIRE CENTER", APART FROM THE MARK AS SHOWN.

THE MARK CONSISTS OF THE WORD MAZDA ABOVE THE WORDS TIRE CENTER, THE DESIGN OF A ROUGHLY RECTANGULAR PARALLELOGRAM, AND THE DESIGN OF A PARTIALLY OBSCURED TIRE, WITH PARTIAL REFLECTIONS AT THE BOTTOM OF THE MARK OF THE WORDS TIRE CENTER AND THE TIRE DESIGN.

FOR AUTOMOBILE DEALERSHIP SERVICES FEATURING AUTOMOBILE TIRES; DISTRIBUTORSHIP SERVICES IN THE FIELD OF AUTOMOBILE TIRES; PROVIDING BUSINESS INFORMATION TO AUTOMOBILE DEALERS IN THE FIELD OF AUTOMOBILE TIRES (U.S. CLS. 100, 101 AND 102).

FIRST USE 10-15-2010; IN COMMERCE 10-15-2010.

SHAUNIA CARLYLE, EXAMINING ATTORNEY

**CLASS 35—(Continued).**

SN 85-173,449. NATIONAL FEDERATION OF COLLEGIATE CLUB SPORTS LEAGUES, LLC, PITTSBURGH, PA. FILED 11-10-2010.

# NCBBA

THE MARK CONSISTS OF STANDARD CHARACTERS WITHOUT CLAIM TO ANY PARTICULAR FONT, STYLE, SIZE, OR COLOR.

OWNER OF U.S. REG. NOS. 3,369,435, 3,815,515 AND OTHERS.

FOR ASSOCIATION SERVICES, NAMELY, PROMOTING THE INTERESTS OF MEMBER COLLEGIATE BASKETBALL TEAMS; BUSINESS ADMINISTRATION AND MANAGEMENT OF COLLEGIATE BASKETBALL TEAM GAME SCHEDULES AND STATISTICS, MARKETING PLANS AND RULES OF PLAY (U.S. CLS. 100, 101 AND 102).

MEGHAN REINHART, EXAMINING ATTORNEY

SN 85-173,748. SHUTT, DANIEL CHARLES, PALM BEACH GARDENS, FL. FILED 11-10-2010.

# 1s In A Lifetime

THE MARK CONSISTS OF STANDARD CHARACTERS WITHOUT CLAIM TO ANY PARTICULAR FONT, STYLE, SIZE, OR COLOR.

FOR ADVERTISING AND PROMOTIONAL SERVICES; ADVERTISING, PROMOTION, AND MARKETING SERVICES IN THE NATURE OF VIRAL MARKETING AND PROMOTION FOR 11/11 CELEBRATION ATTENDEES; ARRANGING AND CONDUCTING SPECIAL EVENTS FOR COMMERCIAL, PROMOTIONAL OR ADVERTISING PURPOSES; ONLINE ADVERTISING AND PROMOTIONAL SERVICES; PROMOTING THE PARTIES AND SPECIAL EVENTS OF OTHERS; PROVIDING MARKETING AND PROMOTION OF SPECIAL EVENTS; SPECIAL EVENT PLANNING FOR COMMERCIAL, PROMOTIONAL OR ADVERTISING PURPOSES (U.S. CLS. 100, 101 AND 102).

BRIDGETT SMITH, EXAMINING ATTORNEY

**CLASS 35—(Continued).**

SN 85-173,883. VMV LIMITED, WAN CHAI, HONG KONG, FILED 11-10-2010.

# SKINFATUATED, SKINTELLECTUAL, SKINGENIOUS

THE MARK CONSISTS OF STANDARD CHARACTERS WITHOUT CLAIM TO ANY PARTICULAR FONT, STYLE, SIZE, OR COLOR.

FOR RETAIL STORE SERVICES AND ON-LINE RETAIL STORE SERVICES FEATURING BEAUTY PRODUCTS, COSMETICS, TOILETRIES, SKIN CARE PREPARATIONS, HAIR CARE PREPARATIONS AND PERSONAL CARE PRODUCTS; COMPUTERIZED ON-LINE ORDERING SERVICES FEATURING BEAUTY PRODUCTS, COSMETICS, SKIN CARE PRODUCTS, FRAGRANCES, AND RELATED PRODUCTS (U.S. CLS. 100, 101 AND 102).

EVELYN BRADLEY, EXAMINING ATTORNEY

SN 85-174,102. HENNIES, VALERIE S., GERMANTOWN, MD. FILED 11-10-2010.

# QUILT SANCTUARY

THE MARK CONSISTS OF STANDARD CHARACTERS WITHOUT CLAIM TO ANY PARTICULAR FONT, STYLE, SIZE, OR COLOR.

NO CLAIM IS MADE TO THE EXCLUSIVE RIGHT TO USE "QUILT", APART FROM THE MARK AS SHOWN.

FOR ON-LINE RETAIL STORE SERVICES FEATURING SUPPLIES AND MATERIALS FOR MAKING QUILTS, INCLUDING FABRIC, BATTING, BINDING, STENCILS, BOOKS, PATTERNS, QUILT KITS, QUILT LABELS, THREAD, BUTTONS, TRIMS, AND SEWING AND QUILTING TOOLS, NOTIONS AND ACCESSORIES (U.S. CLS. 100, 101 AND 102).

TASNEEM HUSSAIN, EXAMINING ATTORNEY

SN 85-174,634. SUNNY SMILES USA INC., KING OF PRUSSIA, PA. FILED 11-11-2010.

# LUMINOSITY

THE MARK CONSISTS OF STANDARD CHARACTERS WITHOUT CLAIM TO ANY PARTICULAR FONT, STYLE, SIZE, OR COLOR.

FOR RETAIL STORE SERVICES IN THE AREA OF TEETH WHITENING SUPPLIES (U.S. CLS. 100, 101 AND 102).

KATHERINE CHANG, EXAMINING ATTORNEY

**CLASS 35—(Continued).**

SN 85-174,709. WYNETT, DAVID, ATLANTA, GA. FILED 11-11-2010.

**PRODIGY WORKS**

THE MARK CONSISTS OF STANDARD CHARACTERS WITHOUT CLAIM TO ANY PARTICULAR FONT, STYLE, SIZE, OR COLOR.

NO CLAIM IS MADE TO THE EXCLUSIVE RIGHT TO USE "WORKS", APART FROM THE MARK AS SHOWN.

FOR BRANDING SERVICES, NAMELY, CONSULTING, DEVELOPMENT, MANAGEMENT AND MARKETING OF BRANDS FOR BUSINESSES; BUSINESS CONSULTATION; CONCEPT AND BRAND DEVELOPMENT SERVICES FOR CORPORATE CLIENTS; MARKETING AND BRANDING SERVICES, NAMELY, PROVIDING CUSTOMIZED COMMUNICATION PROGRAMS TO OBTAIN CONSUMER INSIGHTS AND DEVELOP BRANDING STRATEGIES (U.S. CLS. 100, 101 AND 102).

MARILYN IZZI, EXAMINING ATTORNEY

---

SN 85-174,790. ALLEGIS, LLC, DBA MTM LUXURY LODGING, KIRKLAND, WA. FILED 11-11-2010.

**WOW WHIMSY FUN**

THE MARK CONSISTS OF STANDARD CHARACTERS WITHOUT CLAIM TO ANY PARTICULAR FONT, STYLE, SIZE, OR COLOR.

FOR HOTEL MANAGEMENT FOR OTHERS; RESTAURANT MANAGEMENT FOR OTHERS (U.S. CLS. 100, 101 AND 102).

FIRST USE 2-10-2006; IN COMMERCE 2-10-2006.

JOHN E. MICHOS, EXAMINING ATTORNEY

---

SN 85-174,947. INDEPENDENT GRAPE GROWERS – PASO ROBLES AREA. AKA IGGPRA, PASO ROBLES, CA. FILED 11-11-2010.



THE COLOR(S) PURPLE, GREEN, GRAY IS/ARE CLAIMED AS A FEATURE OF THE MARK.

THE MARK CONSISTS OF 15 GRAPES AS REPRESENTED BY PURPLE HALF-MOONS WITH ONE GREEN STEM, ALL ANGLED AT 45 DEGREES AND SITUATED TO THE LEFT OF THE CAPITALIZED LETTERS "IGGPRA" IN GRAY.

FOR ASSOCIATION SERVICES, NAMELY, PROMOTING THE INTERESTS OF VITICULTURISTS (U.S. CLS. 100, 101 AND 102).

FIRST USE 3-30-2010; IN COMMERCE 3-30-2010.

TAMARA FRAZIER, EXAMINING ATTORNEY

**CLASS 35—(Continued).**

SN 85-174,949. LIVE NATION WORLDWIDE, INC., BEVERLY HILLS, CA. FILED 11-11-2010.

**ARTIST NATION**

THE MARK CONSISTS OF STANDARD CHARACTERS WITHOUT CLAIM TO ANY PARTICULAR FONT, STYLE, SIZE, OR COLOR.

FOR PROMOTING LIVE ENTERTAINMENT EVENTS FOR OTHERS AND MERCHANDISE RELATED THERE TO; BUSINESS AND EVENT MANAGEMENT OF LIVE ENTERTAINMENT EVENTS; OPERATION AND MANAGEMENT OF ENTERTAINMENT VENUES; RETAIL STORE SERVICES FEATURING ARTIST AND TOUR-RELATED MERCHANDISE; PROMOTING TICKET SALES FOR LIVE ENTERTAINMENT EVENTS; ARRANGING FOR PREFERRED BENEFITS AND PRIVILEGES TO LIVE ENTERTAINMENT EVENTS; MANAGEMENT OF PERFORMING ARTISTS, WRITERS, PRODUCERS AND MEDIA TALENT; BUSINESS MANAGEMENT SERVICES, EVENT MANAGEMENT SERVICES, NAMELY PROVIDING MARKETING, PROMOTION AND ORGANIZATION OF SPECIAL EVENTS; BUSINESS MARKETING AND CONSULTING SERVICES IN THE FIELD OF ENTERTAINMENT (U.S. CLS. 100, 101 AND 102).

RAUL CORDOVA, EXAMINING ATTORNEY

---

SN 85-175,101. JNET, SIMI VALLEY, CA. FILED 11-11-2010.

**JNET**

THE MARK CONSISTS OF STANDARD CHARACTERS WITHOUT CLAIM TO ANY PARTICULAR FONT, STYLE, SIZE, OR COLOR.

FOR BUSINESS NETWORKING (U.S. CLS. 100, 101 AND 102).

FIRST USE 10-19-2005; IN COMMERCE 3-3-2008.

ANDREA BUTLER, EXAMINING ATTORNEY

---

SN 85-175,119. FEMFESSONALS LLC, MIAMI, FL. FILED 11-11-2010.

**INNOVATIVELY CONNECTING  
AMBITIOUS WOMEN**

THE MARK CONSISTS OF STANDARD CHARACTERS WITHOUT CLAIM TO ANY PARTICULAR FONT, STYLE, SIZE, OR COLOR.

FOR BUSINESS NETWORKING (U.S. CLS. 100, 101 AND 102).

FIRST USE 12-1-2009; IN COMMERCE 12-1-2009.

ANDREA BUTLER, EXAMINING ATTORNEY

**CLASS 35—(Continued).**

SN 85-175,243. PROMOTION WITH MOTION LLC, COVENTRY, RI. FILED 11-12-2010.

PROMOTION WITH MOTION  
TAKING YOUR MESSAGE TO THE  
STREETS AND DRIVING IT HOME

THE MARK CONSISTS OF STANDARD CHARACTERS WITHOUT CLAIM TO ANY PARTICULAR FONT, STYLE, SIZE, OR COLOR.

FOR ADVERTISING, MARKETING AND PROMOTING THE GOODS AND SERVICES OF OTHERS USING MOBILE HIGH-DEFINITION DIGITAL SCREENS (U.S. CLS. 100, 101 AND 102).

WON TEAK OH, EXAMINING ATTORNEY

**CLASS 35—(Continued).**

SN 85-175,314. RELATIVITY SERVICES, LLC, LOUISVILLE, KY. FILED 11-12-2010.

**HOW DO YOU COMPARE**

THE MARK CONSISTS OF STANDARD CHARACTERS WITHOUT CLAIM TO ANY PARTICULAR FONT, STYLE, SIZE, OR COLOR.

FOR BUSINESS SERVICES, NAMELY PROVIDING BUSINESS MANAGEMENT CONSULTING SERVICES AND DATA RELATING TO STRATEGY AND INSIGHT ABOUT THE AVAILABILITY, PRICING, AND PRICE COMPARISON DATA FOR VARIOUS COMMODITIES OF INDUSTRIAL GOODS AND SERVICES OF OTHERS TO INDUSTRIAL AND SERVICE-SECTOR BUYERS BY MEANS OF A GLOBAL COMPUTER NETWORK; PROVIDING INFORMATION ABOUT TRACKING, ANALYZING AND REPORTING THE RESULTING DATA AND INFORMATION ABOUT THE AVAILABILITY AND COMPARATIVE PRICES FOR VARIOUS COMMODITIES OF INDUSTRIAL GOODS AND SERVICES OF OTHERS TO INDUSTRIAL AND SERVICE-SECTOR BUYERS VIA A GLOBAL COMPUTER NETWORK; PROVIDING INFORMATION ABOUT PRICING AND NEGOTIATION METHODS, PARTICULARIZING IN THE USE OF ANALYTIC MODELS FOR THE UNDERSTANDING OF PRICES AND COMPARATIVE PRICING INFORMATION; BUSINESS CONSULTATION SERVICES IN THE FIELDS OF SUPPLY CHAIN ANALYSIS AS WELL AS DEVELOPMENT OF PROCESSES FOR THE ANALYSIS AND IMPLEMENTATION OF STRATEGY PLANS; BUSINESS MANAGEMENT CONSULTANCY IN THE FIELD OF SOURCING, NAMELY, MANAGING AND ADMINISTERING SOURCING AND PURCHASING STRATEGY AND METHODS; BUSINESS SERVICES, NAMELY, COMBINED GOODS OR SERVICES SOURCING AND COOPERATIVE PURCHASING FOR OTHERS; PROVIDING PRICE COMPARING SERVICES BY PROVIDING A WEBSITE FEATURING PRICE-COMPARISON INFORMATION AND PRODUCT INFORMATION; PROVIDING A WEB SITE FEATURING COMMERCIAL INFORMATION ON SHOPPING; PROVIDING SHOPPERS' GUIDE INFORMATION; PROVISION OF INFORMATION TO INDUSTRIAL AND SERVICE-SECTOR BUYERS REGARDING THE SELECTION OF PRODUCTS AND ITEMS TO BE PURCHASED (U.S. CLS. 100, 101 AND 102).

FIRST USE 7-22-2010; IN COMMERCE 7-22-2010.

WENDY JUN, EXAMINING ATTORNEY

SN 85-175,304. PIQUET, CRISTIANO, MIAMI, FL. FILED 11-12-2010.

**PIQUET RENOVATIONS**

THE MARK CONSISTS OF STANDARD CHARACTERS WITHOUT CLAIM TO ANY PARTICULAR FONT, STYLE, SIZE, OR COLOR.

NO CLAIM IS MADE TO THE EXCLUSIVE RIGHT TO USE "RENOVATIONS", APART FROM THE MARK AS SHOWN.

FOR PROVIDING REFERRALS IN THE FIELD OF HOME RENOVATIONS AND REPAIRS; REFERRALS FOR GENERAL BUILDING CONTRACTORS; REFERRALS IN THE FIELD OF COMMERCIAL PROPERTY RENOVATIONS AND REPAIRS; PROVIDING SALES LEADS FOR THE COMMERCIAL PROPERTY AND RESIDENTIAL PROPERTY RENOVATION, MAINTENANCE AND REPAIR INDUSTRIES (U.S. CLS. 100, 101 AND 102).

INGRID C. EULIN, EXAMINING ATTORNEY



**CLASS 35—(Continued).**

SN 85-175,318. PIQUET, CRISTIANO, MIAMI, FL. FILED 11-12-2010.

**PIQUET MARKETING**

THE MARK CONSISTS OF STANDARD CHARACTERS WITHOUT CLAIM TO ANY PARTICULAR FONT, STYLE, SIZE, OR COLOR.

NO CLAIM IS MADE TO THE EXCLUSIVE RIGHT TO USE "MARKETING", APART FROM THE MARK AS SHOWN.

FOR ADVERTISING AND MARKETING CONSULTANCY; ADVERTISING AND MARKETING SERVICES, NAMELY, PROMOTING THE GOODS AND SERVICES OF OTHERS; ARRANGING AND CONDUCTING MARKETING PROMOTIONAL EVENTS FOR OTHERS; EVENT PLANNING AND MANAGEMENT FOR MARKETING, BRANDING, PROMOTING OR ADVERTISING THE GOODS AND SERVICES OF OTHERS; ORGANIZING, PROMOTING AND CONDUCTING EXHIBITIONS, TRADESHOWS AND EVENTS FOR BUSINESS PURPOSES; PREPARING AND PLACING ADVERTISEMENTS FOR OTHERS (U.S. CLS. 100, 101 AND 102).

INGRID C. EULIN, EXAMINING ATTORNEY

**CLASS 35—(Continued).**

SN 85-176,211. DUSTIN BYRNE, FORMERLY DUSTIN VAIN, DUSTIN JOHN PETROS, NEW YORK, NY. FILED 11-13-2010.

**Givmo**

SN 85-175,866. SECOND MILE LLC, ODESSA, FL. FILED 11-12-2010.

**PROLUXURLIFE**

THE MARK CONSISTS OF STANDARD CHARACTERS WITHOUT CLAIM TO ANY PARTICULAR FONT, STYLE, SIZE, OR COLOR.

FOR ON-LINE CONSIGNMENT MARKETPLACE FOR HIGH END LUXURY GOODS (U.S. CLS. 100, 101 AND 102).

PAM WILLIS, EXAMINING ATTORNEY

THE MARK CONSISTS OF STANDARD CHARACTERS WITHOUT CLAIM TO ANY PARTICULAR FONT, STYLE, SIZE, OR COLOR.

FOR AUCTION MANAGEMENT SERVICES PROVIDED TO OTHERS OVER AN ON-LINE WEB SITE ACCESSED THROUGH A GLOBAL COMPUTER NETWORK; BUSINESS SERVICES, NAMELY, FREIGHT INFORMATION MANAGEMENT SERVICES, SHIPMENT PROCESSING, PREPARING SHIPPING DOCUMENTS AND INVOICES, TRACKING DOCUMENTS, PACKAGES AND FREIGHT OVER COMPUTER NETWORKS, INTRANETS AND INTERNETS; CLASSIFIED ADVERTISING SERVICES; COMPUTERIZED DATABASE MANAGEMENT; ON-LINE AUCTION SERVICES; ON-LINE AUCTION SERVICES IN WHICH BUYERS WHO DONATE TO CHARITY RECEIVE ADDITIONAL BIDDING RIGHTS; ON-LINE TRADING SERVICES IN WHICH SELLER POSTS PRODUCTS TO BE AUCTIONED AND BIDDING IS DONE VIA THE INTERNET; PROVIDING A SEARCHABLE WEBSITE FEATURING THE GOODS AND SERVICES OF OTHER VENDORS; PROVIDING A WEB SITE WHERE USERS CAN POST ITEMS FOR SALE THROUGH ON-LINE CLASSIFIED ADVERTISEMENTS; PROVIDING A WEB SITE WHICH FEATURES ADVERTISEMENTS FOR THE GOODS AND SERVICES OF OTHERS ON A GLOBAL COMPUTER NETWORK; PROVIDING CONSUMER PRODUCT INFORMATION VIA THE INTERNET; PROVIDING INFORMATION ABOUT THE GOODS AND SERVICES OF OTHERS VIA THE GLOBAL COMPUTER NETWORK (U.S. CLS. 100, 101 AND 102).

JAMES GRIFFIN, EXAMINING ATTORNEY

SN 85-175,895. ALLERSERVE LLC, ELLICOTT CITY, MD. FILED 11-12-2010.

**AllerServe**

THE MARK CONSISTS OF STANDARD CHARACTERS WITHOUT CLAIM TO ANY PARTICULAR FONT, STYLE, SIZE, OR COLOR.

FOR BUSINESS CONSULTATION IN THE FIELD OF PROPER HANDLING OF FOODS FOR BUSINESS SERVING PEOPLE WITH FOOD ALLERGIES (U.S. CLS. 100, 101 AND 102).

THEODORE MCBRIDE, EXAMINING ATTORNEY

**CLASS 35—(Continued).**

SN 85-176,341. SAN DIEGO UNIFIED PORT DISTRICT, SAN DIEGO, CA. FILED 11-14-2010.

**THIS IS A GOOD DAY**

THE MARK CONSISTS OF STANDARD CHARACTERS WITHOUT CLAIM TO ANY PARTICULAR FONT, STYLE, SIZE, OR COLOR.

FOR PROMOTING THE ECONOMIC DEVELOPMENT IN THE SAN DIEGO WATERFRONT AREA AND PROMOTING BUSINESS, NAMELY, PROVIDING INFORMATION CONCERNING EVENTS, ATTRACTIONS, ACCOMMODATIONS, DINING, RETAIL-SHOP LOCATIONS, HARBOR ACTIVITIES, MARINE ACTIVITIES, AND BOATING ACTIVITIES AND SERVICES THEREFOR ON AND AROUND THE BAY AREA CONSISTING OF 34 MILES OF WATERFRONT ALONG FIVE CITIES OF SAN DIEGO, CORONADO, CHULA VISTA, IMPERIAL BEACH, AND NATIONAL CITY; PROMOTING TOURISM IN THE SAN DIEGO WATERFRONT AREA AND PROMOTING BUSINESS, NAMELY, PROVIDING INFORMATION CONCERNING EVENTS, ATTRACTIONS, ACCOMMODATIONS, DINING, RETAIL-SHOP LOCATIONS, HARBOR ACTIVITIES, MARINE ACTIVITIES, AND BOATING ACTIVITIES AND SERVICES THEREFOR ON AND AROUND THE BAY AREA CONSISTING OF 34 MILES OF WATERFRONT ALONG FIVE CITIES OF SAN DIEGO, CORONADO, CHULA VISTA, IMPERIAL BEACH, AND NATIONAL CITY AREA (U.S. CLS. 100, 101 AND 102).

MORGAN WYNNE, EXAMINING ATTORNEY

SN 85-176,575. RESTAURANT RESULTS, CONKLIN, NY. FILED 11-15-2010.

**WYCKWYRE**

THE MARK CONSISTS OF STANDARD CHARACTERS WITHOUT CLAIM TO ANY PARTICULAR FONT, STYLE, SIZE, OR COLOR.

FOR ONLINE RECRUITMENT AND HIRING SERVICE FOR RESTAURANTS (U.S. CLS. 100, 101 AND 102). FIRST USE 5-10-2010; IN COMMERCE 5-10-2010. TRACY CROSS, EXAMINING ATTORNEY

**CLASS 35—(Continued).**

SN 85-176,616. MYMINUTES.COM, L.L.C., BOSSIER CITY, LA. FILED 11-15-2010.

**MYMINUTES**

THE MARK CONSISTS OF STANDARD CHARACTERS WITHOUT CLAIM TO ANY PARTICULAR FONT, STYLE, SIZE, OR COLOR.

FOR ONLINE RETAIL STORE SERVICES FEATURING PREPAID AIRTIME FOR MOBILE PHONES AND DEVICES; ONLINE RETAIL STORE SERVICES IN THE FIELD OF PREPAID AIRTIME FOR MOBILE PHONES AND DEVICES FEATURING A CUSTOMER LOYALTY PROGRAM THAT ALLOWS MEMBERS TO REDEEM POINTS TO PURCHASE PREPAID WIRELESS AIRTIME AND MOBILE PHONES AND DEVICES (U.S. CLS. 100, 101 AND 102).

FIRST USE 1-6-2006; IN COMMERCE 1-6-2006.

AMY ALFIERI, EXAMINING ATTORNEY

SN 85-176,662. INDEPENDENT WE STAND, VIRGINIA BEACH, VA. FILED 11-15-2010.



THE MARK CONSISTS OF THE STYLIZED TEXT "INDEPENDENT WE STAND" WITH A PICTURE OF A PERSON IN PLACE OF THE LETTER "A".

FOR PROMOTING PUBLIC AWARENESS OF SUPPORTING SMALL BUSINESSES IN LOCAL ECONOMIES (U.S. CLS. 100, 101 AND 102).

FIRST USE 7-1-2010; IN COMMERCE 7-1-2010.

JUSTINE D. PARKER, EXAMINING ATTORNEY

SN 85-176,663. SCEND, ORLANDO, FL. FILED 11-15-2010.



THE MARK CONSISTS OF A DOLLAR SIGN INSIDE A DIAMOND-SHAPED CREST FOLLOWED BY THE STYLIZED TEXT "RICHDEALERS\$".

FOR BUSINESS CONSULTING SERVICES FOR AUTOMOBILE DEALERSHIPS IN THE AREAS OF MARKETING, ADVERTISING, AND SALES (U.S. CLS. 100, 101 AND 102).

FIRST USE 2-9-2006; IN COMMERCE 2-9-2006.

LINDA MICKLEBURGH, EXAMINING ATTORNEY

**CLASS 35—(Continued).**

SN 85-176,667. ACCLARIS, INC., TAMPA, FL. FILED 11-15-2010.



OWNER OF U.S. REG. NO. 2,690,430.  
THE COLOR(S) RED, TEAL, GREEN, PURPLE AND DARK GREY IS/ARE CLAIMED AS A FEATURE OF THE MARK.

THE MARK CONSISTS OF ONE RED AND TEAL CIRCLE INTERLOCKING WITH ONE PURPLE AND GREEN CIRCLE TO THE LEFT OF THE TERM "ACCLARIS" IN RED, WITH THE TERM "EXPERIENCE MORE" IN DARK GREY UNDERNEATH IT.

FOR MANAGING THE BUSINESS PROCESSES OF OTHER ORGANIZATIONS ON AN OUTSOURCING BASIS (U.S. CLS. 100, 101 AND 102).

FIRST USE 7-12-2010; IN COMMERCE 7-12-2010.  
LINDA MICKLEBURGH, EXAMINING ATTORNEY

**CLASS 35—(Continued).**

SN 85-176,695. FLASK, ORIN, DBA REPBUILDER.COM, SAN FRANCISCO, CA. FILED 11-15-2010.



THE COLOR(S) BLACK AND ORANGE IS/ARE CLAIMED AS A FEATURE OF THE MARK.

THE MARK CONSISTS OF BLACK SQUARE BACKGROUND WITH AN ORANGE STYLIZED "R" WITHIN THE SQUARE.

FOR ON-LINE BUSINESS NETWORKING SERVICES (U.S. CLS. 100, 101 AND 102).

FIRST USE 7-24-2009; IN COMMERCE 7-24-2009.  
LAURA KOVALSKY, EXAMINING ATTORNEY

SN 85-176,673. UBIQUITOUS LEGAL TECHNOLOGY, LLC, EASTON, CT. FILED 11-15-2010.

LAWYERUP

THE MARK CONSISTS OF STANDARD CHARACTERS WITHOUT CLAIM TO ANY PARTICULAR FONT, STYLE, SIZE, OR COLOR.

OWNER OF U.S. REG. NO. 3,407,004.  
FOR ADVERTISING AND MARKETING SERVICES, NAMELY, PROMOTING THE GOODS AND SERVICES OF OTHERS; ATTORNEY REFERRALS (U.S. CLS. 100, 101 AND 102).

DAVID HOFFMAN, EXAMINING ATTORNEY

SN 85-176,757. ART&, COSTA MESA, CA. FILED 11-15-2010.



THE MARK CONSISTS OF A HEART, A LOWERCASE "A" AND THE SYMBOL &.

FOR COMPUTERIZED ON-LINE RETAIL STORE SERVICES IN THE FIELD OF CLOTHING, ACCESSORIES, JEWELRY, ARTWORK, HOUSEHOLD ITEMS; CUSTOMER SERVICE IN THE FIELD OF RETAIL STORE SERVICES; PROVIDING A SEARCHABLE WEBSITE FEATURING THE GOODS AND SERVICES OF OTHER VENDORS (U.S. CLS. 100, 101 AND 102).

FIRST USE 7-1-2010; IN COMMERCE 7-1-2010.  
C. DIONNE CLYBURN, EXAMINING ATTORNEY

**CLASS 35—(Continued).**

SN 85-176,866. LANCE, MARCIE, DBA CREATIVE MARKETING ASSOCIATES, INC., HIGHLAND PARK, IL. FILED 11-15-2010.

## Get Noticed.

THE MARK CONSISTS OF STANDARD CHARACTERS WITHOUT CLAIM TO ANY PARTICULAR FONT, STYLE, SIZE, OR COLOR.

FOR BUSINESS CONSULTING SERVICES RELATING TO THE INTEGRATION OF THE AREAS OF BUSINESS PROCESS TECHNOLOGY, ORGANIZATIONAL LEARNING, CHANGE MANAGEMENT, AND OPERATIONAL SUSTAINABILITY; BUSINESS MANAGEMENT ADVISORY SERVICES RELATING TO FRANCHISING; BUSINESS MANAGEMENT CONSULTING WITH RELATION TO STRATEGY, FINANCING, MARKETING, PRODUCTION, PERSONNEL AND SALE MATTERS FOR COMPANIES INVOLVED WITH THIN FILM AND NANO TECHNOLOGIES AND PLASMA PROCESSES; BUSINESS MANAGEMENT CONSULTING WITH RELATION TO STRATEGY, MARKETING, PRODUCTION, PERSONNEL AND RETAIL SALE MATTERS; BUSINESS MANAGEMENT CONSULTING WITH RELATION TO STRATEGY, MARKETING, SALES, OPERATION, PRODUCT DESIGN PARTICULARLY SPECIALIZING IN THE USE OF ANALYTIC AND STATISTIC MODELS FOR THE UNDERSTANDING AND PREDICTING OF CONSUMERS, BUSINESSES, AND MARKET TRENDS AND ACTIONS (U.S. CLS. 100, 101 AND 102).

ALLISON HOLTZ, EXAMINING ATTORNEY

SN 85-176,876. LEADJEN, LLC, INDIANAPOLIS, IN. FILED 11-15-2010.

## LeadJen

THE MARK CONSISTS OF STANDARD CHARACTERS WITHOUT CLAIM TO ANY PARTICULAR FONT, STYLE, SIZE, OR COLOR.

FOR ADVERTISING, MARKETING AND PROMOTION SERVICES; PROVIDING DEMAND CREATION AND LEAD GENERATION ACTIVITIES AND SERVICES (U.S. CLS. 100, 101 AND 102).

FIRST USE 9-0-2005; IN COMMERCE 9-0-2005.  
HELENE LIWINSKI, EXAMINING ATTORNEY

**CLASS 35—(Continued).**

SN 85-176,881. HENRY J. DESJARDINS, BRENTWOOD, CA. FILED 11-15-2010.

## CHROME ASYLUM

THE MARK CONSISTS OF STANDARD CHARACTERS WITHOUT CLAIM TO ANY PARTICULAR FONT, STYLE, SIZE, OR COLOR.

FOR CONSULTING SERVICES IN THE FIELD OF MARKETING; BUSINESS MARKETING CONSULTING SERVICES; CONSULTING SERVICES IN THE FIELD OF MARKET ANALYSIS; CONSULTING SERVICES IN THE FIELD OF CUSTOMER ANALYSIS; CONSULTING SERVICES IN THE FIELD OF ADVERTISING (U.S. CLS. 100, 101 AND 102).

MICHAEL SOUDERS, EXAMINING ATTORNEY

SN 85-176,922. YODOG MEDIA, LLC, SEATTLE, WA. FILED 11-15-2010.



NO CLAIM IS MADE TO THE EXCLUSIVE RIGHT TO USE "MEDIA", APART FROM THE MARK AS SHOWN.

THE COLOR(S) GREEN AND BROWN IS/ARE CLAIMED AS A FEATURE OF THE MARK.

THE MARK CONSISTS OF "YO DOG" IN GREEN STYLIZED LETTERS; A BROWN HEAD OF A DOG IS IN BETWEEN "YO" AND "DOG"; BELOW "YODOG" IS "MEDIA" IN BROWN STYLIZED LETTERS.

FOR ADVERTISING AND MARKETING SERVICES PROVIDED BY MEANS OF INDIRECT METHODS OF MARKETING COMMUNICATIONS, NAMELY, SOCIAL MEDIA, SEARCH ENGINE MARKETING, INQUIRY MARKETING, INTERNET MARKETING, MOBILE MARKETING, BLOGGING AND OTHER FORMS OF PASSIVE, SHARABLE OR VIRAL COMMUNICATIONS CHANNELS; SOCIAL MEDIA STRATEGY AND MARKETING CONSULTANCY FOCUSING ON HELPING CLIENTS CREATE AND EXTEND THEIR PRODUCT AND BRAND STRATEGIES BY BUILDING VIRALLY ENGAGING MARKETING SOLUTIONS (U.S. CLS. 100, 101 AND 102).

FIRST USE 5-24-2010; IN COMMERCE 5-24-2010.  
KATHERINE STOIDES, EXAMINING ATTORNEY

**CLASS 35—(Continued).**

SN 85-177,128. DO IT IN PERSON LLC, FOREST HILLS, NY.  
FILED 11-15-2010.

**DO IT IN PERSON**

THE MARK CONSISTS OF STANDARD CHARACTERS WITHOUT CLAIM TO ANY PARTICULAR FONT, STYLE, SIZE, OR COLOR.

OWNER OF U.S. REG. NO. 3,870,514.  
FOR ON-LINE PROFESSIONAL NETWORKING SERVICES; PROVIDING A WEBSITE WITH INFORMATION RELATING TO BUSINESS NETWORKING (U.S. CLS. 100, 101 AND 102).

FIRST USE 3-8-2010; IN COMMERCE 3-8-2010.  
BARBARA A. GOLD, EXAMINING ATTORNEY

**CLASS 35—(Continued).**

SN 85-177,293. DICE SOLUTIONS LLC, NEW YORK, NY.  
FILED 11-15-2010.

**Get a leg up.**

THE MARK CONSISTS OF STANDARD CHARACTERS WITHOUT CLAIM TO ANY PARTICULAR FONT, STYLE, SIZE, OR COLOR.

FOR PROVIDING AN ON-LINE DIRECTORY INFORMATION SERVICE FEATURING INFORMATION REGARDING PET-RELATED SERVICES FROM INSURED AND BONDED BUSINESSES, WHERE USERS CAN BE CONTACTED BY THE SERVICES THEY ARE INTERESTED IN SO THAT MORE INFORMATION CAN BE PROVIDED (U.S. CLS. 100, 101 AND 102).

FIRST USE 7-15-2010; IN COMMERCE 7-15-2010.  
ALICE BENMAMAN, EXAMINING ATTORNEY

SN 85-177,182. REPUBLIC CLOTHING CORPORATION,  
NEW YORK, NY. FILED 11-15-2010.

**PLY**

THE MARK CONSISTS OF STANDARD CHARACTERS WITHOUT CLAIM TO ANY PARTICULAR FONT, STYLE, SIZE, OR COLOR.

FOR RETAIL APPAREL STORES (U.S. CLS. 100, 101 AND 102).

CHRISTINE COOPER, EXAMINING ATTORNEY

SN 85-177,490. ROY F GLASSBERG, BOCA RATON, FL.  
FILED 11-16-2010.

**PURSUING BALANCE**

THE MARK CONSISTS OF STANDARD CHARACTERS WITHOUT CLAIM TO ANY PARTICULAR FONT, STYLE, SIZE, OR COLOR.

FOR BUSINESS ADVISORY SERVICES, CONSULTANCY AND INFORMATION (U.S. CLS. 100, 101 AND 102).

FIRST USE 1-1-2010; IN COMMERCE 1-1-2010.  
KARANENDRA S. CHHINA, EXAMINING ATTORNEY

SN 85-177,199. BERNARD B. KAUFMAN, WEST HAMPTON,  
NY. FILED 11-15-2010.

**GALS GALORE & GUYS TOO**

THE MARK CONSISTS OF STANDARD CHARACTERS WITHOUT CLAIM TO ANY PARTICULAR FONT, STYLE, SIZE, OR COLOR.

FOR PRODUCT DEMONSTRATION (U.S. CLS. 100, 101 AND 102).

CHRISTINE COOPER, EXAMINING ATTORNEY

SN 85-177,540. RX GEAR, LLC, QUINCY, MA. FILED 11-16-2010.

The logo for 'scrubology' features the word in a lowercase, rounded, sans-serif font. The letter 'y' is stylized to resemble a stethoscope, with its stem forming the vertical part and its two earpieces curving downwards and outwards.

THE MARK CONSISTS OF "SCRUBOLGY" WITH THE "Y" ELEMENT FORMING A STETHOSCOPE WHICH CURLS BELOW THE "LOG" ELEMENT OF THE MARK.

FOR RETAIL AND ONLINE STORE SERVICES FEATURING CLOTHING AND MEDICAL AND HEALTH-CARE APPAREL AND RELATED ACCESSORIES (U.S. CLS. 100, 101 AND 102).

FIRST USE 11-3-2010; IN COMMERCE 11-3-2010.  
CARYN GLASSER, EXAMINING ATTORNEY

**CLASS 35—(Continued).**

SN 85-177,664. BARNEY'S, INC., NEW YORK, NY. FILED 11-16-2010.

# B-SOCIAL

THE MARK CONSISTS OF STANDARD CHARACTERS WITHOUT CLAIM TO ANY PARTICULAR FONT, STYLE, SIZE, OR COLOR.

FOR RETAIL STORE SERVICES FEATURING CLOTHING, ACCESSORIES, GIFT ITEMS FOR THE HOME, STATIONERY, PERFUME, COSMETICS, AND CANDLES (U.S. CLS. 100, 101 AND 102).

FIRST USE 12-0-2009; IN COMMERCE 12-0-2009.  
B. PARADEWELAI, EXAMINING ATTORNEY

**CLASS 35—(Continued).**

SN 85-177,718. BARNEY'S, INC., NEW YORK, NY. FILED 11-16-2010.



THE MARK CONSISTS OF A LARGE UPPERCASE LETTER "B" WITH A SOLID HORIZONTAL LINE TO THE RIGHT OF THE LETTER "B" AND ABOVE THE UPPERCASE LETTER "A" IN THE TERM SOCIAL THAT IS PRINTED IN ALL UPPERCASE LETTERS AT THE BOTTOM OF THE "B" DESIGN.

FOR RETAIL STORE SERVICES FEATURING CLOTHING, ACCESSORIES, GIFT ITEMS FOR THE HOME, STATIONERY, PERFUME, COSMETICS, AND CANDLES (U.S. CLS. 100, 101 AND 102).

FIRST USE 12-0-2009; IN COMMERCE 12-0-2009.  
B. PARADEWELAI, EXAMINING ATTORNEY

SN 85-177,819. BUY AND SHIP, LLC, DANA POINT, CA. FILED 11-16-2010.

# X & OH

THE MARK CONSISTS OF STANDARD CHARACTERS WITHOUT CLAIM TO ANY PARTICULAR FONT, STYLE, SIZE, OR COLOR.

FOR RETAIL STORE SERVICES FEATURING ADULT ENTERTAINMENT PRODUCTS (U.S. CLS. 100, 101 AND 102).

TOBY BULLOFF, EXAMINING ATTORNEY

SN 85-177,678. ROCHESTER DIAMONDS AND GOLD, INC., ROCHESTER, NY. FILED 11-16-2010.

# USARDI

THE MARK CONSISTS OF STANDARD CHARACTERS WITHOUT CLAIM TO ANY PARTICULAR FONT, STYLE, SIZE, OR COLOR.

FOR WHOLESALE AND ONLINE WHOLESALE STORE SERVICES FEATURING DIAMONDS (U.S. CLS. 100, 101 AND 102).

ELLEN PERKINS, EXAMINING ATTORNEY

SN 85-177,866. WANN, TRACY A., DUNLAP, IL. FILED 11-16-2010.

# Wanna Be Fashionable? Wanna Save Money?

THE MARK CONSISTS OF STANDARD CHARACTERS WITHOUT CLAIM TO ANY PARTICULAR FONT, STYLE, SIZE, OR COLOR.

FOR RETAIL CONSIGNMENT STORES FEATURING WOMEN'S AND CHILDREN'S GENTLY WORN CLOTHING AND ACCESSORIES (U.S. CLS. 100, 101 AND 102).

FIRST USE 1-1-2010; IN COMMERCE 1-1-2010.  
APRIL HESIK, EXAMINING ATTORNEY

**CLASS 35—(Continued).**

SN 85-177,929. SKILLSHARE, INC., NEW YORK, NY. FILED 11-16-2010.

THE COLOR(S) ORANGE AND BLUE IS/ARE CLAIMED AS A FEATURE OF THE MARK.

THE MARK CONSISTS OF THE WORD "SKILLSHARE" IN CAPITAL LETTERS. EACH LETTER IN THE WORD IS PART BLUE AND PART ORANGE.

FOR OPERATING ON-LINE MARKETPLACES FOR SELLERS OF GOODS AND/OR SERVICES (U.S. CLS. 100, 101 AND 102).

FIRST USE 11-16-2010; IN COMMERCE 11-16-2010.  
DEIRDRE ROBERTSON, EXAMINING ATTORNEY

---

SN 85-177,948. WEBLOYALTY.COM, INC., NORWALK, CT. FILED 11-16-2010.

## LITTLE BIRDIE

THE MARK CONSISTS OF STANDARD CHARACTERS WITHOUT CLAIM TO ANY PARTICULAR FONT, STYLE, SIZE, OR COLOR.

FOR PROMOTING THE GOODS AND SERVICES OF OTHERS BY PROVIDING A WEBSITE FEATURING COUPONS, REBATES, PRICE-COMPARISON INFORMATION, PRODUCT REVIEWS, LINKS TO THE RETAIL WEBSITES OF OTHERS, AND DISCOUNT INFORMATION (U.S. CLS. 100, 101 AND 102).

MARGARET POWER, EXAMINING ATTORNEY

---

SN 85-178,056. ST. LOUIS MAGAZINE, LLC, ST. LOUIS, MO. FILED 11-16-2010.

## HELLO GOODBUY!

THE MARK CONSISTS OF STANDARD CHARACTERS WITHOUT CLAIM TO ANY PARTICULAR FONT, STYLE, SIZE, OR COLOR.

FOR PROMOTING THE GOODS AND SERVICES OF OTHERS BY PROVIDING A WEBSITE THAT OFFERS DISCOUNTED GIFT VOUCHERS AND CERTIFICATES REDEEMABLE FOR THE GOODS AND SERVICES OF OTHERS; ONLINE RETAIL STORE SERVICES FEATURING GIFT VOUCHERS AND CERTIFICATES REDEEMABLE FOR THE GOODS AND SERVICES OF OTHERS (U.S. CLS. 100, 101 AND 102).

LAURIE KAUFMAN, EXAMINING ATTORNEY

**CLASS 35—(Continued).**

SN 85-178,094. BUDDHA'S AND GOUDHA'S, LTD., BOULDER, CO. FILED 11-16-2010.

## BUDDHA'S AND GOUDHA'S

THE MARK CONSISTS OF STANDARD CHARACTERS WITHOUT CLAIM TO ANY PARTICULAR FONT, STYLE, SIZE, OR COLOR.

FOR ON-LINE RETAIL STORE SERVICES FEATURING PIPES FOR TOBACCO USE, SMOKING ACCESSORIES, LIGHTERS, LINGERIE, NOVELTY ITEMS, TOBACCO, TOBACCO JARS, TOBACCO PIPE CLEANERS, TOBACCO WATER PIPES; RETAIL STORE SERVICES FEATURING PIPES FOR TOBACCO USE, SMOKING ACCESSORIES, LIGHTERS, LINGERIE, NOVELTY ITEMS, TOBACCO, TOBACCO JARS, TOBACCO PIPE CLEANERS, TOBACCO WATER PIPES (U.S. CLS. 100, 101 AND 102).

FIRST USE 2-1-2008; IN COMMERCE 12-30-2009.  
BRENDAN REGAN, EXAMINING ATTORNEY

---

SN 85-178,154. BUDDHA'S AND GOUDHA'S, LTD., BOULDER, CO. FILED 11-16-2010.

## ENLIGHTENED SMOKE SHOP

THE MARK CONSISTS OF STANDARD CHARACTERS WITHOUT CLAIM TO ANY PARTICULAR FONT, STYLE, SIZE, OR COLOR.

NO CLAIM IS MADE TO THE EXCLUSIVE RIGHT TO USE "SMOKE SHOP", APART FROM THE MARK AS SHOWN.

FOR ON-LINE RETAIL STORE SERVICES FEATURING PIPES FOR TOBACCO USE, SMOKING ACCESSORIES, LIGHTERS, LINGERIE, NOVELTY ITEMS, TOBACCO, TOBACCO JARS, TOBACCO PIPE CLEANERS, TOBACCO WATER PIPES; RETAIL STORE SERVICES FEATURING PIPES FOR TOBACCO USE, SMOKING ACCESSORIES, LIGHTERS, LINGERIE, NOVELTY ITEMS, TOBACCO, TOBACCO JARS, TOBACCO PIPE CLEANERS, TOBACCO WATER PIPES (U.S. CLS. 100, 101 AND 102).

FIRST USE 2-1-2008; IN COMMERCE 12-30-2009.  
BRENDAN REGAN, EXAMINING ATTORNEY

**CLASS 35—(Continued).**

SN 85-178,174. CRAFTWORKS RESTAURANTS & BREWERIES, INC., CHATTANOOGA, TN. FILED 11-16-2010.

**CRAFTWORKS**

THE MARK CONSISTS OF STANDARD CHARACTERS WITHOUT CLAIM TO ANY PARTICULAR FONT, STYLE, SIZE, OR COLOR.

FOR ASSISTANCE IN BUSINESS MANAGEMENT AND PRODUCT COMMERCIALIZATION, WITHIN THE FRAMEWORK OF A FRANCHISE CONTRACT; ASSISTANCE IN FRANCHISED COMMERCIAL BUSINESS MANAGEMENT; BUSINESS MANAGEMENT ADVISORY SERVICES RELATING TO FRANCHISING; BUSINESS MANAGEMENT AND CONSULTATION IN THE FIELD OF FRANCHISED RESTAURANTS AND BREWERY RESTAURANTS; RESTAURANT FRANCHISING, NAMELY, OFFERING BUSINESS MANAGEMENT ASSISTANCE IN THE ESTABLISHMENT AND/OR OPERATION OF RESTAURANTS (U.S. CLS. 100, 101 AND 102).

FIRST USE 11-15-2010; IN COMMERCE 11-15-2010.  
DOMINICK J. SALEMI, EXAMINING ATTORNEY

SN 85-178,301. SR HOLDINGS, LLC, LEXINGTON, MA. FILED 11-16-2010.

**A PASSION FOR THE SEA**

THE MARK CONSISTS OF STANDARD CHARACTERS WITHOUT CLAIM TO ANY PARTICULAR FONT, STYLE, SIZE, OR COLOR.

FOR RETAIL SHOE AND FASHION ACCESSORIES STORE SERVICES; COMPUTERIZED ON-LINE RETAIL STORE SERVICES IN THE FIELD OF FOOTWEAR, APPAREL, ACCESSORIES AND BAGS, ACCESSIBLE VIA GLOBAL COMPUTER NETWORKS (U.S. CLS. 100, 101 AND 102).

FIRST USE 2-0-2009; IN COMMERCE 2-0-2009.  
JOHN DWYER, EXAMINING ATTORNEY

**CLASS 35—(Continued).**

SN 85-178,303. RMC OF ILLINOIS, INC., PHILADELPHIA, PA. FILED 11-16-2010.

**RIGHTGPS**

THE MARK CONSISTS OF STANDARD CHARACTERS WITHOUT CLAIM TO ANY PARTICULAR FONT, STYLE, SIZE, OR COLOR.

FOR BUSINESS AND STRATEGIC MANAGEMENT CONSULTING SERVICES, NAMELY, DEVELOPMENT AND IMPLEMENTATION OF EMPLOYEE REVIEW, DEVELOPMENT AND PROGRESSION PROGRAMS AND IN THE DEVELOPMENT AND IMPLEMENTATION OF LONG-RANGE MANAGEMENT CONTINUITY AND SUCCESSION PLANS (U.S. CLS. 100, 101 AND 102).

FIRST USE 11-16-2010; IN COMMERCE 11-16-2010.  
GEORGE LORENZO, EXAMINING ATTORNEY

SN 85-178,404. COMPUBIZ ENTERPRISES, VAN NUYS, CA. FILED 11-16-2010.

**Compubiz**

THE MARK CONSISTS OF STANDARD CHARACTERS WITHOUT CLAIM TO ANY PARTICULAR FONT, STYLE, SIZE, OR COLOR.

FOR ON-LINE RETAIL STORE SERVICES FEATURING CONSUMER ELECTRONICS, COMPUTERS, COMPUTER PERIPHERALS, TELECOMMUNICATIONS DEVICES, SECURITY CAMERAS, AND SOFTWARE (U.S. CLS. 100, 101 AND 102).

FIRST USE 7-1-2001; IN COMMERCE 7-1-2001.  
PAULA MAHONEY, EXAMINING ATTORNEY

SN 85-178,426. YELLOWSTICKER.COM, INC., ANAHEIM, CT. FILED 11-16-2010.

**YELLOWSTICKER**

THE MARK CONSISTS OF STANDARD CHARACTERS WITHOUT CLAIM TO ANY PARTICULAR FONT, STYLE, SIZE, OR COLOR.

FOR PROVIDING A WEB SITE WHERE USERS CAN POST ITEMS FOR SALE THROUGH ON-LINE CLASSIFIED ADVERTISEMENTS (U.S. CLS. 100, 101 AND 102).

FIRST USE 6-1-2010; IN COMMERCE 6-1-2010.  
BRIAN NEVILLE, EXAMINING ATTORNEY



**CLASS 35—(Continued).**

SN 85-178,441. YELLOWSTICKER.COM, INC., ANAHEIM, CT. FILED 11-16-2010.



THE MARK CONSISTS OF A HORIZONTAL OUTLINE OF A FIGURE 8 WITH THE WORDING "YELLOWSTICKER.COM" INSIDE.

FOR PROVIDING A WEB SITE WHERE USERS CAN POST ITEMS FOR SALE THROUGH ON-LINE CLASSIFIED ADVERTISEMENTS (U.S. CLS. 100, 101 AND 102).  
FIRST USE 6-1-2010; IN COMMERCE 6-1-2010.  
BRIAN NEVILLE, EXAMINING ATTORNEY

SN 85-178,517. ROTENBERG, MERIL, SOLOMON, BERTIGER & GUTTILLA, PC, SADDLE BROOK, NJ. FILED 11-17-2010.

**Creative Thinkers.  
Innovative Solutions.**

THE MARK CONSISTS OF STANDARD CHARACTERS WITHOUT CLAIM TO ANY PARTICULAR FONT, STYLE, SIZE, OR COLOR.

FOR ACCOUNT AUDITING; ACCOUNTANCY SERVICES; ACCOUNTING CONSULTATION; ACCOUNTING FOR THIRD PARTIES; ACCOUNTING SERVICES; BUSINESS INFORMATION AND ACCOUNTING ADVISORY SERVICES; BUSINESS MANAGEMENT CONSULTATION AND SERVICES, NAMELY, MANAGING AND ADMINISTERING NON-CORE FUNCTIONS, NAMELY, MAILING AND SHIPPING, RECORDS MANAGEMENT, INFORMATION SERVICES, ADMINISTRATION, PAYROLL AND ACCOUNTING, AND TELEMARKETING SERVICES (U.S. CLS. 100, 101 AND 102).

BRENDAN REGAN, EXAMINING ATTORNEY

**CLASS 35—(Continued).**

SN 85-178,522. ROTENBERG, MERIL, SOLOMON, BERTIGER & GUTTILLA, PC, SADDLE BROOK, NJ. FILED 11-17-2010.

**Where results exceed  
expectations.**

THE MARK CONSISTS OF STANDARD CHARACTERS WITHOUT CLAIM TO ANY PARTICULAR FONT, STYLE, SIZE, OR COLOR.

FOR ACCOUNT AUDITING; ACCOUNTANCY SERVICES; ACCOUNTING CONSULTATION; ACCOUNTING FOR THIRD PARTIES; ACCOUNTING SERVICES; BUSINESS INFORMATION AND ACCOUNTING ADVISORY SERVICES; BUSINESS MANAGEMENT CONSULTATION AND SERVICES, NAMELY, MANAGING AND ADMINISTERING NON-CORE FUNCTIONS, NAMELY, MAILING AND SHIPPING, RECORDS MANAGEMENT, INFORMATION SERVICES, ADMINISTRATION, PAYROLL AND ACCOUNTING, AND TELEMARKETING SERVICES (U.S. CLS. 100, 101 AND 102).

BRENDAN REGAN, EXAMINING ATTORNEY

SN 85-178,564. PWM E-TAIL INC, LANCASTER, PA. FILED 11-17-2010.

**MUSICALLY GIFTED**

THE MARK CONSISTS OF STANDARD CHARACTERS WITHOUT CLAIM TO ANY PARTICULAR FONT, STYLE, SIZE, OR COLOR.

FOR RETAIL SHOPS FEATURING MUSIC GIFT PACKAGES (U.S. CLS. 100, 101 AND 102).

FIRST USE 6-1-2010; IN COMMERCE 8-1-2010.

KIMBERLY PERRY, EXAMINING ATTORNEY

SN 85-178,662. BENCHMASTER FURNITURE, LLC, ANAHEIM, CA. FILED 11-17-2010.

**BENCHMASTER**

THE MARK CONSISTS OF STANDARD CHARACTERS WITHOUT CLAIM TO ANY PARTICULAR FONT, STYLE, SIZE, OR COLOR.

FOR DISTRIBUTORSHIP SERVICES IN THE FIELD OF FURNITURE; WHOLESALE AND RETAIL STORE SERVICES FEATURING FURNITURE (U.S. CLS. 100, 101 AND 102).

FIRST USE 4-1-2002; IN COMMERCE 4-1-2002.

JENNIFER VASQUEZ, EXAMINING ATTORNEY

**CLASS 35—(Continued).**

SN 85-178,687. PLANET SMOOTHIE, LLC, ATLANTA, GA. FILED 11-17-2010.

CHANGING THE WAY THE  
PLANET LIVES

THE MARK CONSISTS OF STANDARD CHARACTERS WITHOUT CLAIM TO ANY PARTICULAR FONT, STYLE, SIZE, OR COLOR.

FOR RETAIL STORE SERVICES FEATURING FROZEN DRINKS CONTAINING COLD FRUIT AND OTHER NATURAL INGREDIENTS, SPORTS DRINKS, SNACK FOODS, SANDWICHES, VITAMINS, HERBS, T-SHIRTS, POLO SHIRTS, HATS AND CUPS; ON-LINE RETAIL STORE SERVICES FEATURING VITAMINS, HERBS, T-SHIRTS, POLO SHIRTS, HATS AND CUPS (U.S. CLS. 100, 101 AND 102).

ZACHARY BELLO, EXAMINING ATTORNEY

SN 85-178,698. MUSYCK CORP., CARROLLTON, TX. FILED 11-17-2010.

FASTFAN

THE MARK CONSISTS OF STANDARD CHARACTERS WITHOUT CLAIM TO ANY PARTICULAR FONT, STYLE, SIZE, OR COLOR.

FOR ON-LINE RETAIL STORE SERVICES FEATURING DOWNLOADABLE DIGITAL CONTENT, NAMELY, PRE-RECORDED MUSIC, VIDEO, AND ELECTRONIC BOOKS (U.S. CLS. 100, 101 AND 102).

TEJBIR SINGH, EXAMINING ATTORNEY

**CLASS 35—(Continued).**

SN 85-178,744. BROTHERHOOD 74 MOTORCYCLE RIDERS, CARLSBAD, NM. FILED 11-17-2010.



NO CLAIM IS MADE TO THE EXCLUSIVE RIGHT TO USE "BROTHERHOOD", APART FROM THE MARK AS SHOWN.

THE MARK CONSISTS OF A BANNER WITH THE STYLIZED TEXT "BROTHERHOOD MR". AT THE BOTTOM THERE IS THE STYLIZED TEXT "74" ENCLOSED IN AN ABSTRACT DESIGN.

FOR ASSOCIATION SERVICES, NAMELY, PROMOTING THE INTERESTS OF MOTORCYCLE ENTHUSIASTS (U.S. CLS. 100, 101 AND 102).

FIRST USE 7-25-1985; IN COMMERCE 7-25-1985.

FRANK LATTUCA, EXAMINING ATTORNEY

SN 85-179,252. INDUSTRIAL AUTOMATION COMPONENTS, INC., CORNELIUS, NC. FILED 11-17-2010.

VALWORX

THE MARK CONSISTS OF STANDARD CHARACTERS WITHOUT CLAIM TO ANY PARTICULAR FONT, STYLE, SIZE, OR COLOR.

OWNER OF U.S. REG. NO. 3,610,106.

FOR ONLINE RETAIL STORE SERVICES FEATURING VALVES, ACTUATORS AND PLUMBING FITTINGS (U.S. CLS. 100, 101 AND 102).

BRENDAN REGAN, EXAMINING ATTORNEY

**CLASS 35—(Continued).**

SN 85-179,301. SIKARIA, KHUSHBU, WASHINGTON, DC. FILED 11-17-2010.



THE MARK CONSISTS OF THE STYLIZED TEXT "S".  
FOR ON-LINE RETAIL STORE SERVICES FEATURING LUXURY FASHION APPAREL AND ACCESSORIES (U.S. CLS. 100, 101 AND 102).  
FIRST USE 1-8-2010; IN COMMERCE 1-8-2010.  
TRACY CROSS, EXAMINING ATTORNEY

SN 85-179,320. MICHAEL LEADON, DBA ROAD WARRIOR NETWORK, SAN JOSE, CA. FILED 11-17-2010.

Road Warrior Network

THE MARK CONSISTS OF STANDARD CHARACTERS WITHOUT CLAIM TO ANY PARTICULAR FONT, STYLE, SIZE, OR COLOR.  
NO CLAIM IS MADE TO THE EXCLUSIVE RIGHT TO USE "NETWORK", APART FROM THE MARK AS SHOWN.  
FOR ASSOCIATION SERVICES, NAMELY, PROMOTING THE INTERESTS OF TECHNOLOGY PROFESSIONALS (U.S. CLS. 100, 101 AND 102).  
FIRST USE 2-1-2008; IN COMMERCE 2-1-2008.  
TASNEEM HUSSAIN, EXAMINING ATTORNEY

**CLASS 35—(Continued).**

SN 85-179,417. GEORGE THOMPSON, CAMARILLO, CA. FILED 11-17-2010.

TWICE THE QUALITY HALF THE PRICE

THE MARK CONSISTS OF STANDARD CHARACTERS WITHOUT CLAIM TO ANY PARTICULAR FONT, STYLE, SIZE, OR COLOR.  
FOR ON-LINE RETAIL STORE SERVICES FEATURING DIAMONDS, WATCHES AND JEWELRY; RETAIL GIFT SHOPS; RETAIL JEWELRY STORES; RETAIL SHOPS FEATURING DIAMONDS, WATCHES AND JEWELRY; RETAIL STORE SERVICES FEATURING DIAMONDS, WATCHES AND JEWELRY; RETAIL STORES FEATURING DIAMONDS, WATCHES AND JEWELRY; RETAIL DIAMONDS, WATCHES AND JEWELRY STORES; WHOLESALE STORES FEATURING DIAMONDS, WATCHES AND JEWELRY IN INTERNATIONAL CLASS 35 (U.S. CLS. 100, 101 AND 102).  
CAROL SPILS, EXAMINING ATTORNEY

SN 85-179,523. MASCHHOFF, JASON, GLEN CARBON, IL. AND MASCHHOFF, TANIA, GLEN CARBON, IL. FILED 11-17-2010.

MIDWESTCOASTING

THE MARK CONSISTS OF STANDARD CHARACTERS WITHOUT CLAIM TO ANY PARTICULAR FONT, STYLE, SIZE, OR COLOR.  
FOR ON-LINE RETAIL STORE SERVICES FEATURING CLOTHING, APPAREL, CAMPING SUPPLIES, BOATING SUPPLIES, HIKING SUPPLIES, FISHING SUPPLIES, SWIMMING AND BEACH SUPPLIES, SPORTING GOODS, HOME DECOR, AND OTHER MERCHANDISE OF INTEREST TO INDIVIDUALS WITH AN ACTIVE LIFESTYLE OR WHO ENJOY THE OUTDOORS (U.S. CLS. 100, 101 AND 102).  
ALICIA COLLINS, EXAMINING ATTORNEY

**CLASS 35—(Continued).**

SN 85-180,027. SAVVY TOWN LLC, CHARLOTTE, NC. FILED 11-18-2010.

**SAVVYTOWN**

THE MARK CONSISTS OF STANDARD CHARACTERS WITHOUT CLAIM TO ANY PARTICULAR FONT, STYLE, SIZE, OR COLOR.

FOR ADVERTISING AND MARKETING SERVICES PROVIDED BY MEANS OF INDIRECT METHODS OF MARKETING COMMUNICATIONS, NAMELY, SOCIAL MEDIA, SEARCH ENGINE MARKETING, INQUIRY MARKETING, INTERNET MARKETING, MOBILE MARKETING, BLOGGING AND OTHER FORMS OF PASSIVE, SHARABLE OR VIRAL COMMUNICATIONS CHANNELS; ADVERTISING AND MARKETING SERVICES, NAMELY, PROMOTING THE GOODS AND SERVICES OF OTHERS; ADVERTISING AND PUBLICITY SERVICES, NAMELY, PROMOTING THE GOODS, SERVICES, BRAND IDENTITY AND COMMERCIAL INFORMATION AND NEWS OF THIRD PARTIES THROUGH PRINT, AUDIO, VIDEO, DIGITAL AND ON-LINE MEDIUM; ADVERTISING SERVICES, NAMELY, PROMOTING AND MARKETING THE GOODS AND SERVICES OF OTHERS IN THE FIELD OF UPSCALE CHOICES SUCH AS CULTURAL EVENTS, RESTAURANTS, SHOPPING, AND TRAVEL VIA PRINT AND ELECTRONIC MEDIA; ADVERTISING SERVICES, PUBLIC RELATIONS AND MARKETING SERVICES, NAMELY, PROMOTING AND MARKETING THE GOODS AND SERVICES OF OTHERS THROUGH ALL PUBLIC COMMUNICATION MEANS; ADVERTISING, MARKETING AND PROMOTION SERVICES; ARRANGING AND CONDUCTING MARKETING PROMOTIONAL EVENTS FOR OTHERS; ARRANGING AND CONDUCTING SPECIAL EVENTS FOR COMMERCIAL, PROMOTIONAL OR ADVERTISING PURPOSES; CONSULTING SERVICES IN THE FIELD OF INTERNET MARKETING; INFORMATION, ADVISORY AND CONSULTANCY SERVICES RELATING TO BUSINESS AND MANAGEMENT OR BUSINESS ADMINISTRATION, INCLUDING SUCH SERVICES PROVIDED ON LINE OR VIA THE INTERNET; ON-LINE ADVERTISING AND MARKETING SERVICES; ON-LINE ADVERTISING SERVICES FOR OTHERS; PROMOTING THE GOODS AND SERVICES OF OTHERS BY PROVIDING A COMMUNITY-DRIVEN WEB SITE FEATURING USER-SUBMITTED CONTENT IN THE NATURE OF COUPONS, REBATES, PRICE-COMPARISON INFORMATION, PRODUCT REVIEWS, LINKS TO THE RETAIL WEB SITES OF OTHERS, AND DISCOUNT INFORMATION; THE BRINGING TOGETHER, FOR THE BENEFIT OF OTHERS, OF A VARIETY OF GOODS AND SERVICES, ENABLING CUSTOMERS TO CONVENIENTLY VIEW AND PURCHASE THOSE GOODS AND SERVICES FROM AN INTERNET WEB SITE PARTICULARLY SPECIALIZING IN THE MARKETING OF THE SALE OF GOODS AND SERVICES OF OTHERS (U.S. CLS. 100, 101 AND 102).

REBECCA POVARCHUK, EXAMINING ATTORNEY

**CLASS 35—(Continued).**

SN 85-180,055. THE SHADE STORE LLC, PORT CHESTER, NY. FILED 11-18-2010.

**WHAT'S ON YOUR WINDOWS?**

THE MARK CONSISTS OF STANDARD CHARACTERS WITHOUT CLAIM TO ANY PARTICULAR FONT, STYLE, SIZE, OR COLOR.

FOR ON-LINE RETAIL STORE SERVICES FEATURING WINDOW BLINDS, CURTAINS, DECORATIVE WINDOW TREATMENTS AND RELATED ACCESSORIES (U.S. CLS. 100, 101 AND 102).

FIRST USE 10-1-2010; IN COMMERCE 10-1-2010.  
MAYUR VAGHANI, EXAMINING ATTORNEY

SN 85-180,213. CITIGROUP INC., NEW YORK, NY. FILED 11-18-2010.

**CITI TREASURY DIAGNOSTICS**

THE MARK CONSISTS OF STANDARD CHARACTERS WITHOUT CLAIM TO ANY PARTICULAR FONT, STYLE, SIZE, OR COLOR.

OWNER OF U.S. REG. NOS. 1,181,467, 3,555,337 AND OTHERS.

NO CLAIM IS MADE TO THE EXCLUSIVE RIGHT TO USE "TREASURY", APART FROM THE MARK AS SHOWN.

FOR ANALYZING AND COMPILING DATA FOR MEASURING PERFORMANCE IN THE FIELD OF TREASURY-RELATED FINANCIAL OPERATIONS; BUSINESS CONSULTATION SERVICES, NAMELY, PROVIDING BEST PRACTICE BENCHMARKING AND INFORMATION REGARDING BEST PRACTICES IN THE FIELD OF TREASURY-RELATED FINANCIAL OPERATIONS (U.S. CLS. 100, 101 AND 102).

FIRST USE 5-21-2009; IN COMMERCE 5-21-2009.  
JOHN GARTNER, EXAMINING ATTORNEY

SN 85-180,327. UNIVERSAL UNDERSTANDING, INC., JACKSONVILLE, FL. FILED 11-18-2010.

**QoE**

THE MARK CONSISTS OF STANDARD CHARACTERS WITHOUT CLAIM TO ANY PARTICULAR FONT, STYLE, SIZE, OR COLOR.

FOR BUSINESS CONSULTATION IN THE FIELD OF INFORMATION TECHNOLOGY; BUSINESS CONSULTATION SERVICES; BUSINESS CONSULTING AND INFORMATION SERVICES (U.S. CLS. 100, 101 AND 102).

FIRST USE 11-12-2010; IN COMMERCE 11-12-2010.  
JIM RINGLE, EXAMINING ATTORNEY

**CLASS 35—(Continued).**

SN 85-180,429. LARSON, DONALD A., MEDIA, PA. FILED 11-18-2010.

## The Sunshine Approach

THE MARK CONSISTS OF STANDARD CHARACTERS WITHOUT CLAIM TO ANY PARTICULAR FONT, STYLE, SIZE, OR COLOR.

FOR DEVELOPMENT OF CONCEPTS FOR BUSINESS ECONOMY; DEVELOPMENT OF MARKETING STRATEGIES AND CONCEPTS; ECONOMIC CONSULTING AND INFORMATION FOR THE INDUSTRIAL AND COMMERCIAL SECTORS FOR PLANNING, ORGANIZING, MONITORING AND CARRYING OUT UNIQUE AND COMPLEX PROJECTS IN DIFFERENT SECTORS OF ONE OR SEVERAL COMPANIES; PROMOTING THE ECONOMIC DEVELOPMENT IN THE AGRICULTURAL COMMUNITIES OF SUB-SAHARAN AFRICA (U.S. CLS. 100, 101 AND 102).

FIRST USE 1-17-2010; IN COMMERCE 11-10-2010.  
KEVON CHISOLM, EXAMINING ATTORNEY

SN 85-180,470. MLA MULTIBRAND HOLDINGS, INC., VERNON, CA. FILED 11-18-2010.

## TWELVE TWO

THE MARK CONSISTS OF STANDARD CHARACTERS WITHOUT CLAIM TO ANY PARTICULAR FONT, STYLE, SIZE, OR COLOR.

FOR RETAIL STORES FEATURING MEN'S AND WOMEN'S CLOTHING, FOOTWEAR, HEADGEAR, EYEWEAR, SUNGLASSES, COSMETICS, PERFUMES, BELTS, BAGS, WALLETS, PURSES, BACK PACKS, COSMETIC BAGS AND LEATHER GOODS, NOTEBOOKS, JEWELRY AND WATCHES, AND ACCESSORIES (U.S. CLS. 100, 101 AND 102).

LAURA KOVALSKY, EXAMINING ATTORNEY

SN 85-180,535. MLA MULTIBRAND HOLDINGS, INC., VERNON, CA. FILED 11-18-2010.

## 12-2

THE MARK CONSISTS OF STANDARD CHARACTERS WITHOUT CLAIM TO ANY PARTICULAR FONT, STYLE, SIZE, OR COLOR.

FOR RETAIL STORES FEATURING MEN'S AND WOMEN'S CLOTHING, FOOTWEAR, HEADGEAR, EYEWEAR, SUNGLASSES, COSMETICS, PERFUMES, BELTS, BAGS, WALLETS, PURSES, BACK PACKS, COSMETIC BAGS AND LEATHER GOODS, NOTEBOOKS, JEWELRY AND WATCHES, AND ACCESSORIES (U.S. CLS. 100, 101 AND 102).

LAURA KOVALSKY, EXAMINING ATTORNEY

**CLASS 35—(Continued).**

SN 85-180,600. STAR, JENNIFER C, WARREN, NJ. FILED 11-18-2010.

## AdminSuperStar

THE MARK CONSISTS OF STANDARD CHARACTERS WITHOUT CLAIM TO ANY PARTICULAR FONT, STYLE, SIZE, OR COLOR.

FOR PROVIDING ON-LINE EMPLOYMENT INFORMATION IN THE FIELD OF ADMINISTRATIVE SUPPORT STAFF (U.S. CLS. 100, 101 AND 102).

FIRST USE 6-1-2009; IN COMMERCE 8-15-2010.  
HANNO RITTNER, EXAMINING ATTORNEY

SN 85-181,024. BARNEY'S, INC., NEW YORK, NY. FILED 11-19-2010.



THE MARK CONSISTS OF A STYLIZED UPPERCASE LETTER "B" TO THE LEFT OF THE TERM "SOCIAL" IN UPPERCASE LETTERS WITH A HYPHEN BETWEEN THE LETTER "B" AND THE TERM "SOCIAL".

FOR RETAIL STORE SERVICES FEATURING CLOTHING, ACCESSORIES, GIFT ITEMS FOR THE HOME, STATIONERY, PERFUME, COSMETICS, AND CANDLES (U.S. CLS. 100, 101 AND 102).

FIRST USE 12-0-2009; IN COMMERCE 12-0-2009.  
B. PARADEWELAI, EXAMINING ATTORNEY

SN 85-181,068. AGILE IT, INC., SAN DIEGO, CA. FILED 11-19-2010.

## Your Agile Technology Partner for Your Agile Business

THE MARK CONSISTS OF STANDARD CHARACTERS WITHOUT CLAIM TO ANY PARTICULAR FONT, STYLE, SIZE, OR COLOR.

FOR INFORMATION TECHNOLOGY (IT) CONSULTING FOCUSING ON COMPUTER SUPPORT AND MAINTENANCE ; DESIGN OF DATA/VOIP NETWORKS ; CONSULTING SERVICES IN THE FIELD OF OFFICE AND WORKPLACE AUTOMATION (U.S. CLS. 100, 101 AND 102).

FIRST USE 1-15-2006; IN COMMERCE 1-15-2006.  
DOMINIC J. FERRAIUOLO, EXAMINING ATTORNEY

**CLASS 35—(Continued).**

SN 85-181,401. MELISSA SMITH, DBA HOUNDSTOOTH & POLKA DOTS, WEST PLAINS, MO. FILED 11-19-2010.

**HOUNDSTOOTH & POLKA DOTS**

THE MARK CONSISTS OF STANDARD CHARACTERS WITHOUT CLAIM TO ANY PARTICULAR FONT, STYLE, SIZE, OR COLOR.

FOR WHOLESALE AND RETAIL STORE SERVICES FEATURING APPAREL AND ACCESSORIES WITH PROPRIETARY DESIGNS PRINTED THEREON (U.S. CLS. 100, 101 AND 102).

FIRST USE 9-13-2010; IN COMMERCE 9-13-2010.  
TARAH HARDY, EXAMINING ATTORNEY

SN 85-181,426. KENNEL, JOHN C, SAN ANTONIO, TX. FILED 11-19-2010.

**SALERT**

THE MARK CONSISTS OF STANDARD CHARACTERS WITHOUT CLAIM TO ANY PARTICULAR FONT, STYLE, SIZE, OR COLOR.

FOR PROMOTING THE GOODS AND SERVICES OF OTHERS BY PROVIDING A WEBSITE FEATURING COUPONS, REBATES, PRICE-COMPARISON INFORMATION, PRODUCT REVIEWS, LINKS TO THE RETAIL WEBSITES OF OTHERS, AND DISCOUNT INFORMATION (U.S. CLS. 100, 101 AND 102).

KATHERINE CHANG, EXAMINING ATTORNEY

SN 85-181,441. PEOPLERESULTS, LLC, IRVING, TX. FILED 11-19-2010.

**PEOPLERESULTS**

THE MARK CONSISTS OF STANDARD CHARACTERS WITHOUT CLAIM TO ANY PARTICULAR FONT, STYLE, SIZE, OR COLOR.

FOR MANAGEMENT AND BUSINESS CONSULTING SERVICES IN THE FIELDS OF ORGANIZATIONAL DEVELOPMENT, TALENT MANAGEMENT AND EXECUTIVE LEADERSHIP (U.S. CLS. 100, 101 AND 102).

FIRST USE 12-0-2003; IN COMMERCE 1-0-2004.  
KATHERINE CHANG, EXAMINING ATTORNEY

**CLASS 35—(Continued).**

SN 85-181,470. WASILCHAK, CRAIG, ARLINGTON, TX. FILED 11-19-2010.



NO CLAIM IS MADE TO THE EXCLUSIVE RIGHT TO USE "FREEBUYERQUOTES.COM", APART FROM THE MARK AS SHOWN.

THE MARK CONSISTS OF THE WORDS, "FREEBUYER-QUOTES.COM WHERE SMART PEOPLE COME TO BUY". THE LETTER "Q" IN FREEBUYERQUOTES.COM IS IN A SHADED CIRCLE.

FOR BUSINESS SERVICES, NAMELY, PROVIDING COMPUTER DATABASES REGARDING THE PURCHASE AND SALE OF A WIDE VARIETY OF PRODUCTS AND SERVICES OF OTHERS; PROMOTING THE GOODS AND SERVICES OF OTHERS BY PROVIDING A WEB SITE FEATURING COUPONS, REBATES, PRICE-COMPARISON INFORMATION, PRODUCT REVIEWS, LINKS TO THE RETAIL WEB SITES OF OTHERS, AND DISCOUNT INFORMATION; PROMOTING THE GOODS AND SERVICES OF OTHERS BY PROVIDING HYPERTEXT LINKS TO THE WEB SITES OF OTHERS; PROVIDING A WEB SITE AT WHICH USERS CAN OFFER GOODS FOR SALE AND BUY GOODS OFFERED BY OTHERS (U.S. CLS. 100, 101 AND 102).

TEJBIR SINGH, EXAMINING ATTORNEY

SN 85-181,471. MELISSA SMITH, DBA HOUNDSTOOTH & POLKA DOTS, WEST PLAINS, MO. FILED 11-19-2010.

**H&PD**

THE MARK CONSISTS OF STANDARD CHARACTERS WITHOUT CLAIM TO ANY PARTICULAR FONT, STYLE, SIZE, OR COLOR.

FOR WHOLESALE AND RETAIL STORE SERVICES FEATURING APPAREL AND ACCESSORIES WITH PROPRIETARY DESIGNS PRINTED THEREON (U.S. CLS. 100, 101 AND 102).

FIRST USE 9-13-2010; IN COMMERCE 9-13-2010.  
TARAH HARDY, EXAMINING ATTORNEY

SN 85-181,474. HAPPINESS IS PETS OF ORLAND PARK, INC., LEMONT, IL. FILED 11-19-2010.

**Happiness Is Pets**

THE MARK CONSISTS OF STANDARD CHARACTERS WITHOUT CLAIM TO ANY PARTICULAR FONT, STYLE, SIZE, OR COLOR.

FOR RETAIL PET STORES (U.S. CLS. 100, 101 AND 102).

FIRST USE 1-1-1995; IN COMMERCE 1-1-1995.  
TARAH HARDY, EXAMINING ATTORNEY

**CLASS 35—(Continued).**

SN 85-181,588. MOOLALA, INC., AUSTIN, TX. FILED 11-19-2010.

# MOOLALA

THE MARK CONSISTS OF STANDARD CHARACTERS WITHOUT CLAIM TO ANY PARTICULAR FONT, STYLE, SIZE, OR COLOR.

FOR PROMOTING THE GOODS AND SERVICES OF OTHERS; ARRANGING AND CONDUCTING AN INCENTIVE REFERRAL PROGRAM TO PROMOTE THE SALE OF GOODS AND SERVICES OF OTHERS (U.S. CLS. 100, 101 AND 102).

JESSICA A. POWERS, EXAMINING ATTORNEY

SN 85-181,670. KELSEY ADVERTISING & DESIGN, LLC, LAGRANGE, GA. FILED 11-19-2010.

# Results Addicts

THE MARK CONSISTS OF STANDARD CHARACTERS WITHOUT CLAIM TO ANY PARTICULAR FONT, STYLE, SIZE, OR COLOR.

FOR ADVERTISING AND PUBLICITY SERVICES, NAMELY, PROMOTING THE GOODS, SERVICES, BRAND IDENTITY AND COMMERCIAL INFORMATION AND NEWS OF THIRD PARTIES THROUGH PRINT, AUDIO, VIDEO, DIGITAL AND ON-LINE MEDIUM; BRAND CONCEPT AND BRAND DEVELOPMENT SERVICES FOR CORPORATE CLIENTS (U.S. CLS. 100, 101 AND 102).

FIRST USE 2-1-2009; IN COMMERCE 2-1-2009.  
JANICE KIM, EXAMINING ATTORNEY

SN 85-181,676. GARVIN, THOMAS, FALLS CHURCH, VA. FILED 11-19-2010.

# worldwidegarvin.com

THE MARK CONSISTS OF STANDARD CHARACTERS WITHOUT CLAIM TO ANY PARTICULAR FONT, STYLE, SIZE, OR COLOR.

FOR BUSINESS CONSULTING AND INFORMATION SERVICES (U.S. CLS. 100, 101 AND 102).

FIRST USE 12-14-2008; IN COMMERCE 1-1-2009.  
JANICE KIM, EXAMINING ATTORNEY

**CLASS 35—(Continued).**

SN 85-181,929. BUSINESS WOMEN RISING, INC., NEWPORT BEACH, CA. FILED 11-21-2010.

# Business World Rising

THE MARK CONSISTS OF STANDARD CHARACTERS WITHOUT CLAIM TO ANY PARTICULAR FONT, STYLE, SIZE, OR COLOR.

NO CLAIM IS MADE TO THE EXCLUSIVE RIGHT TO USE "BUSINESS WORLD", APART FROM THE MARK AS SHOWN.

FOR BUSINESS CONSULTATION IN THE FIELD OF BUSINESS LEADERSHIP DEVELOPMENT; BUSINESS MANAGEMENT CONSULTATION IN THE FIELD OF EXECUTIVE AND LEADERSHIP DEVELOPMENT; BUSINESS NETWORKING; CONSULTING SERVICES IN BUSINESS LEADERSHIP DEVELOPMENT AND BUSINESS MANAGEMENT; MANAGEMENT AND BUSINESS CONSULTING SERVICES IN THE FIELD OF MANAGEMENT, LEADERSHIP AND EXECUTIVE DEVELOPMENT AND LEADERSHIP DIVERSITY (U.S. CLS. 100, 101 AND 102).

HOWARD SMIGA, EXAMINING ATTORNEY

SN 85-182,930. MEMBERSHIP RECRUITING, LLC, EUGENE, OR. FILED 11-22-2010.



THE MARK CONSISTS OF "CDL-LINK" IN STYLIZED TEXT, ALONG WITH A SILHOUETTE OF A TRUCK AND A STYLIZED REPRESENTATION OF A STREET.

FOR MANAGEMENT AND BUSINESS CONSULTING SERVICES IN THE FIELD OF COMMERCIALLY LICENSED TRUCK DRIVERS; DATABASE MANAGEMENT CONNECTED WITH THE HIRING OF TRANSPORT DRIVERS, NAMELY, MANAGING A DATABASE THAT IDENTIFIES COMMERCIALLY LICENSED TRUCK DRIVERS THAT HAVE BEEN PRE-SCREENED AND MEET SPECIFIED CRITERIA; EMPLOYMENT SERVICES, NAMELY, PROVIDING A WEB SITE FEATURING EMPLOYMENT INFORMATION TO SUPPORT RECRUITING AND GENERAL CANDIDATE SCREENING PROCESSES FOR THE HIRING OF TRUCK DRIVERS (U.S. CLS. 100, 101 AND 102).

FIRST USE 5-20-2010; IN COMMERCE 9-24-2010.  
LAURIE MAYES, EXAMINING ATTORNEY

**CLASS 35—(Continued).**

SN 85-184,960. QUIKSILVER AMERICAS, INC., HUNTINGTON BEACH, CA. FILED 11-24-2010.

# SRBO

THE MARK CONSISTS OF STANDARD CHARACTERS WITHOUT CLAIM TO ANY PARTICULAR FONT, STYLE, SIZE, OR COLOR.

FOR CLASSIFIED ADVERTISING SERVICES (U.S. CLS. 100, 101 AND 102).

MARIA-VICTORIA SUAREZ, EXAMINING ATTORNEY

SN 85-187,039. HUMAN RESOURCES ASSOCIATION OF NEW YORK, TRENTON, NJ. FILED 11-30-2010.

# GEN XTRAORDINARY

THE MARK CONSISTS OF STANDARD CHARACTERS WITHOUT CLAIM TO ANY PARTICULAR FONT, STYLE, SIZE, OR COLOR.

FOR PROVIDING CAREER INFORMATION (U.S. CLS. 100, 101 AND 102).

COLLEEN KEARNEY, EXAMINING ATTORNEY

SN 85-190,119. NATIONAL AUTOMATED CLEARING HOUSE ASSOCIATION, HERNDON, VA. FILED 12-3-2010.



**U.S. International  
Committee**  
A NACHA International Payments Program

OWNER OF U.S. REG. NOS. 1,468,237, 3,377,043 AND 3,419,145.

NO CLAIM IS MADE TO THE EXCLUSIVE RIGHT TO USE "U.S. INTERNATIONAL COMMITTEE" AND "INTERNATIONAL PAYMENTS PROGRAM", APART FROM THE MARK AS SHOWN.

THE MARK CONSISTS OF THE WORDING U.S. INTERNATIONAL COMMITTEE A NACHA INTERNATIONAL PAYMENTS PROGRAM NEXT TO A MAP OF THE WORLD BEHIND TWO CIRCULAR DESIGNS WITH ARROWS AT THE END.

FOR ASSOCIATION SERVICES, NAMELY, PROMOTING THE INTERESTS OF THE ELECTRONIC PAYMENTS INDUSTRY (U.S. CLS. 100, 101 AND 102).

FIRST USE 6-0-2009; IN COMMERCE 6-0-2009.

ADA HAN, EXAMINING ATTORNEY

**CLASS 35—(Continued).**

SN 85-190,126. NATIONAL AUTOMATED CLEARING HOUSE ASSOCIATION, HERNDON, VA. FILED 12-3-2010.



**Global Payments Forum**  
A NACHA International Payments Program

OWNER OF U.S. REG. NOS. 1,468,237, 3,377,043 AND 3,419,145.

NO CLAIM IS MADE TO THE EXCLUSIVE RIGHT TO USE "GLOBAL PAYMENTS FORUM" AND "INTERNATIONAL PAYMENTS PROGRAM", APART FROM THE MARK AS SHOWN.

THE MARK CONSISTS OF THE WORDING "GLOBAL PAYMENTS FORUM A NACHA INTERNATIONAL PAYMENTS PROGRAM" NEXT TO A MAP OF THE WORLD BEHIND TWO CIRCULAR DESIGNS WITH ARROWS AT THE END.

FOR ASSOCIATION SERVICES, NAMELY, PROMOTING THE INTERESTS OF THE ELECTRONIC PAYMENTS INDUSTRY (U.S. CLS. 100, 101 AND 102).

FIRST USE 6-0-2009; IN COMMERCE 6-0-2009.

ADA HAN, EXAMINING ATTORNEY

SN 85-195,625. BEST WESTERN INTERNATIONAL, INC., PHOENIX, AZ. FILED 12-10-2010.

# WINDSHIELD WARRIOR

THE MARK CONSISTS OF STANDARD CHARACTERS WITHOUT CLAIM TO ANY PARTICULAR FONT, STYLE, SIZE, OR COLOR.

FOR CUSTOMER LOYALTY SERVICES AND CUSTOMER CLUB SERVICES, FOR COMMERCIAL, PROMOTIONAL AND/OR ADVERTISING PURPOSES (U.S. CLS. 100, 101 AND 102).

REBECCA POVARCHUK, EXAMINING ATTORNEY

SN 85-197,399. N.V. PERRICONE LLC, MERIDEN, CT. FILED 12-14-2010.

# FEED HUNGRY SKIN

THE MARK CONSISTS OF STANDARD CHARACTERS WITHOUT CLAIM TO ANY PARTICULAR FONT, STYLE, SIZE, OR COLOR.

NO CLAIM IS MADE TO THE EXCLUSIVE RIGHT TO USE "SKIN", APART FROM THE MARK AS SHOWN.

FOR RETAIL STORE SERVICES FEATURING SKIN CARE PRODUCTS (U.S. CLS. 100, 101 AND 102).

FIRST USE 7-17-2010; IN COMMERCE 7-17-2010.

GIANCARLO CASTRO, EXAMINING ATTORNEY



**CLASS 35—(Continued).**

SN 85-197,558. N.V. PERRICONE LLC, MERIDEN, CT.  
FILED 12-14-2010.

FEED HUNGRY SKIN WITH THE  
WORLD'S MOST POWERFUL  
SUPERFOODS

THE MARK CONSISTS OF STANDARD CHARACTERS  
WITHOUT CLAIM TO ANY PARTICULAR FONT, STYLE,  
SIZE, OR COLOR.

NO CLAIM IS MADE TO THE EXCLUSIVE RIGHT TO  
USE "SKIN", APART FROM THE MARK AS SHOWN.

FOR RETAIL STORE SERVICES FEATURING SKIN  
CARE PRODUCTS (U.S. CLS. 100, 101 AND 102).

FIRST USE 7-17-2010; IN COMMERCE 7-17-2010.  
GIANCARLO CASTRO, EXAMINING ATTORNEY

SN 85-199,956. AOL INC., DULLES, VA. FILED 12-16-2010.

THE NEXT BIG IDEA?

THE MARK CONSISTS OF STANDARD CHARACTERS  
WITHOUT CLAIM TO ANY PARTICULAR FONT, STYLE,  
SIZE, OR COLOR.

FOR PROVIDING INFORMATION, NEWS, AND COM-  
MENTARY IN THE FIELD OF BUSINESS, BUSINESS  
IDEAS, BUSINESS STRATEGY, BUSINESS DEVELOP-  
MENT, AND BUSINESS ENTREPRENEURSHIP (U.S.  
CLS. 100, 101 AND 102).

FIRST USE 12-16-2010; IN COMMERCE 12-16-2010.  
ALLISON SCHRODY, EXAMINING ATTORNEY

SN 85-203,959. SEPHORA, BOULOGNE BILLAN COURT,  
FRANCE, FILED 12-22-2010.

SEPHORA HOT NOW

THE MARK CONSISTS OF STANDARD CHARACTERS  
WITHOUT CLAIM TO ANY PARTICULAR FONT, STYLE,  
SIZE, OR COLOR.

OWNER OF U.S. REG. NOS. 2,431,967, 2,431,968 AND  
2,770,691.

FOR RETAIL STORE AND ON-LINE RETAIL STORE  
SERVICES FEATURING PERFUMERY, COSMETICS,  
MAKE-UP, SKINCARE AND BEAUTY PRODUCTS  
AND ACCESSORIES, BATH AND BODY PRODUCTS  
AND ACCESSORIES, AND HAIR CARE PRODUCTS,  
PREPARATIONS AND ACCESSORIES (U.S. CLS. 100,  
101 AND 102).

JUDITH HELFMAN, EXAMINING ATTORNEY

**CLASS 35—(Continued).**

SN 85-204,363. QUINSTREET, INC., FOSTER CITY, CA.  
FILED 12-22-2010.

INTELLIMATCH

THE MARK CONSISTS OF STANDARD CHARACTERS  
WITHOUT CLAIM TO ANY PARTICULAR FONT, STYLE,  
SIZE, OR COLOR.

FOR PROMOTING, ADVERTISING AND MARKET-  
ING THE ON-LINE WEB SITES OF OTHERS; PROMOT-  
ING THE GOODS AND SERVICES OF OTHERS VIA THE  
INTERNET; ADVERTISING AND MARKETING FOR  
OTHERS VIA THE INTERNET; PROMOTING THE  
GOODS AND SERVICES OF OTHERS BY PROVIDING  
HYPERTEXT LINKS TO THE WEB SITES OF OTHERS  
(U.S. CLS. 100, 101 AND 102).

KAREN K. BUSH, EXAMINING ATTORNEY

SN 85-212,716. MAZDA MOTOR OF AMERICA, INC.,  
IRVINE, CA. FILED 1-7-2011.

DRIVE CENTER

THE MARK CONSISTS OF STANDARD CHARACTERS  
WITHOUT CLAIM TO ANY PARTICULAR FONT, STYLE,  
SIZE, OR COLOR.

FOR AUTOMOBILE DEALERSHIP SERVICES (U.S.  
CLS. 100, 101 AND 102).

FIRST USE 8-0-2002; IN COMMERCE 8-0-2002.

SHAUNIA CARLYLE, EXAMINING ATTORNEY

SN 85-213,316. NIKE, INC., BEAVERTON, OR. FILED 1-7-  
2011.

NIKE BETTER WORLD

THE MARK CONSISTS OF STANDARD CHARACTERS  
WITHOUT CLAIM TO ANY PARTICULAR FONT, STYLE,  
SIZE, OR COLOR.

FOR PROMOTING PUBLIC INTEREST AND AWARE-  
NESS IN THE FIELD OF SPORTS, SPORTS COMPETI-  
TIONS, PHYSICAL FITNESS AND TRAINING, AND  
RELATING TO HUMANITARIAN, COMMUNITY,  
HEALTH, AND ENVIRONMENTAL SUSTAINABILITY  
ISSUES; PROVIDING A WEBSITE PROMOTING PUBLIC  
INTEREST AND AWARENESS IN THE FIELD OF  
SPORTS, SPORTS COMPETITIONS, PHYSICAL FITNESS  
AND TRAINING, AND RELATING TO HUMANITAR-  
IAN, COMMUNITY, HEALTH, AND ENVIRONMENTAL  
SUSTAINABILITY ISSUES FEATURING INFORMATION  
ON ENVIRONMENTALLY PREFERRED MATERIALS,  
WASTE REDUCTION, AND OTHER MEANS OF REDU-  
CING ENVIRONMENTAL IMPACT OF CONSUMER  
PRODUCTS MANUFACTURING AND DISTRIBUTION  
(U.S. CLS. 100, 101 AND 102).

ERNEST SHOSHO, EXAMINING ATTORNEY

**CLASS 35—(Continued).**

SN 85-219,971. WOLVERINE WORLD WIDE, INC., ROCK-FORD, MI. FILED 1-18-2011.

**HUSH PUPPIES**

THE MARK CONSISTS OF STANDARD CHARACTERS WITHOUT CLAIM TO ANY PARTICULAR FONT, STYLE, SIZE, OR COLOR.

OWNER OF U.S. REG. NOS. 663,849, 767,344 AND OTHERS.

FOR RETAIL STORE AND ON-LINE RETAIL STORE SERVICES FEATURING FOOTWEAR, CLOTHING, HEADGEAR, BAGS AND ACCESSORIES (U.S. CLS. 100, 101 AND 102).

DORITT L. CARROLL, EXAMINING ATTORNEY

SN 85-220,622. WOLVERINE WORLD WIDE, INC., ROCK-FORD, MI. FILED 1-19-2011.

**WOLVERINE**

THE MARK CONSISTS OF STANDARD CHARACTERS WITHOUT CLAIM TO ANY PARTICULAR FONT, STYLE, SIZE, OR COLOR.

OWNER OF U.S. REG. NOS. 730,465, 1,495,861 AND OTHERS.

FOR RETAIL STORE AND ON-LINE RETAIL STORE SERVICES FEATURING FOOTWEAR, CLOTHING, HEADGEAR, BAGS AND ACCESSORIES (U.S. CLS. 100, 101 AND 102).

DORITT L. CARROLL, EXAMINING ATTORNEY

SN 85-220,668. DOW JONES & COMPANY, INC., NEW YORK, NY. FILED 1-19-2011.

**WSJ**

THE MARK CONSISTS OF STANDARD CHARACTERS WITHOUT CLAIM TO ANY PARTICULAR FONT, STYLE, SIZE, OR COLOR.

OWNER OF U.S. REG. NOS. 2,119,170, 2,575,504 AND OTHERS.

FOR RETAIL STORE SERVICES FEATURING A WIDE VARIETY OF CONSUMER GOODS OF OTHERS; ADVERTISING AND MARKETING (U.S. CLS. 100, 101 AND 102).

MARK SHINER, EXAMINING ATTORNEY

**CLASS 35—(Continued).**

SN 85-221,457. WALGREEN CO., DEERFIELD, IL. FILED 1-19-2011.

**WELL CONNECTED**

THE MARK CONSISTS OF STANDARD CHARACTERS WITHOUT CLAIM TO ANY PARTICULAR FONT, STYLE, SIZE, OR COLOR.

FOR ON-LINE RETAIL DRUG STORE SERVICES THAT OFFER IN-STORE PICK-UP OF ON-LINE PURCHASES (U.S. CLS. 100, 101 AND 102).

ALICE BENMAMAN, EXAMINING ATTORNEY

SN 85-223,262. JEWELS AND PINSTRIPES, PLEASANTON, CA. FILED 1-21-2011.

**Familywood**

THE MARK CONSISTS OF STANDARD CHARACTERS WITHOUT CLAIM TO ANY PARTICULAR FONT, STYLE, SIZE, OR COLOR.

FOR IC 035. US 100 101 102. G AND S: PROMOTING THE GOODS AND SERVICES OF OTHERS BY ARRANGING FOR SPONSORS' ITEMS TO BE MARKETED AT CHARITY AND OTHER EVENTS (U.S. CLS. 100, 101 AND 102).

FIRST USE 1-21-2011; IN COMMERCE 1-21-2011.

AMY HELLA, EXAMINING ATTORNEY

**CLASS 36—INSURANCE AND FINANCIAL**

SN 76-682,836. ENTRE GLOBAL SERVICES, INC., MALVERN, PA. FILED 10-11-2007.

**PolicyPlus**

THE MARK CONSISTS OF STANDARD CHARACTERS WITHOUT CLAIM TO ANY PARTICULAR FONT, STYLE, SIZE, OR COLOR.

FOR LOAN SERVICES, NAMELY, A LOAN PROGRAM FOR OWNERS OF CERTAIN INSURANCE POLICIES IN WHICH ADDITIONAL INSURANCE COVERAGE IS PROVIDED THROUGH PAYMENT OF ADDITIONAL PREMIUMS WITHOUT CONCURRENT ADDITIONAL PAYMENT OF SUCH PREMIUMS BY THE POLICY HOLDER (U.S. CLS. 100, 101 AND 102).

JENNIFER VASQUEZ, EXAMINING ATTORNEY

**CLASS 36—(Continued).**

SN 76-704,056. RESMARK EQUITY PARTNERS, LLC, LOS ANGELES, CA. FILED 8-9-2010.

**RESMARK EQUITY PARTNERS**

THE MARK CONSISTS OF STANDARD CHARACTERS WITHOUT CLAIM TO ANY PARTICULAR FONT, STYLE, SIZE, OR COLOR.

OWNER OF U.S. REG. NO. 2,855,580.

NO CLAIM IS MADE TO THE EXCLUSIVE RIGHT TO USE "EQUITY PARTNERS", APART FROM THE MARK AS SHOWN.

FOR REAL ESTATE AND FINANCIAL SERVICES, NAMELY, PROVIDING INVESTMENT AND FINANCING SERVICES RELATED TO REAL ESTATE DEVELOPMENT (U.S. CLS. 100, 101 AND 102).

FIRST USE 11-11-2002; IN COMMERCE 11-11-2002.

LINDA ESTRADA, EXAMINING ATTORNEY

SN 76-704,424. ALZHEIMER'S FOUNDATION OF AMERICA, INC., NEW YORK, NY. FILED 9-9-2010.



OWNER OF U.S. REG. NOS. 3,099,830, 3,604,818 AND OTHERS.

NO CLAIM IS MADE TO THE EXCLUSIVE RIGHT TO USE "TELETHON", APART FROM THE MARK AS SHOWN.

THE MARK CONSISTS OF THE WORDING "TOGETHER FOR CARE TELETHON ALZHEIMER'S FOUNDATION OF AMERICA" WITH A HEART AND HANDS DESIGN.

SEC. 2(F) AS TO "ALZHEIMER'S FOUNDATION OF AMERICA".

FOR CHARITABLE FUND RAISING SERVICES BY MEANS OF AN ANNUAL FUNDRAISING EVENT TO RAISE AWARENESS OF AND SUPPORT TREATMENT OF ALZHEIMER'S DISEASE OR RELATED DEMENTIA (U.S. CLS. 100, 101 AND 102).

REGINA DRUMMOND, EXAMINING ATTORNEY

SN 76-704,869. HILLWOOD DEVELOPMENT COMPANY, LLC, DALLAS, TX. FILED 10-13-2010.



OWNER OF U.S. REG. NOS. 1,563,802, 2,723,273 AND OTHERS.

NO CLAIM IS MADE TO THE EXCLUSIVE RIGHT TO USE "FLORIDA", APART FROM THE MARK AS SHOWN.

THE MARK CONSISTS OF THE STYLIZED WORDINGS "ALLIANCE FLORIDA", WITH A FIVE-POINT START DESIGN APPEARING BETWEEN THEM.

FOR REAL ESTATE LEASING, BROKERAGE AND MANAGEMENT SERVICES (U.S. CLS. 100, 101 AND 102).

FIRST USE 9-23-2010; IN COMMERCE 9-23-2010.

DAWN HAN, EXAMINING ATTORNEY

**CLASS 36—(Continued).**

SN 77-530,232. THE TORONTO-DOMINION BANK, TORONTO, ONTARIO, CANADA, FILED 7-24-2008.



PRIORITY CLAIMED UNDER SEC. 44(D) ON CANADA APPLICATION NO. 1404544, FILED 7-23-2008, REG. NO. 783906, DATED 12-1-2010, EXPIRES 12-1-2025.

OWNER OF U.S. REG. NOS. 1,640,759, 1,649,009 AND 2,750,706.

NO CLAIM IS MADE TO THE EXCLUSIVE RIGHT TO USE "BANK", APART FROM THE MARK AS SHOWN.

THE COLOR(S) GREEN, WHITE AND BLACK IS/ARE CLAIMED AS A FEATURE OF THE MARK.

THE MARK CONSISTS OF A GREEN BOX THAT IS THE BACKGROUND FOR THE LETTERS "TD" DEPICTED IN WHITE, WITH THE WORD "BANK" FOLLOWING IN BLACK.

FOR BANKING SERVICES; REAL ESTATE INVESTMENT, REAL ESTATE MANAGEMENT AND REAL ESTATE FINANCING; SECURITIES BROKERAGE AND DEALER SERVICES; ESTATE TRUST MANAGEMENT SERVICES; CREDIT CARD SERVICES, LENDING SERVICES, NAMELY, CONSUMER, COMMERCIAL, MORTGAGE, REAL ESTATE AND WHOLESALE, INVESTMENT ADVISORY AND FINANCIAL ADVISORY SERVICES; INVESTMENT MANAGEMENT AND FINANCIAL MANAGEMENT SERVICES; INSURANCE UNDERWRITING SERVICES IN THE FIELDS OF TRAVEL, LIFE, HEALTH, ACCIDENT, FIRE, VEHICLE, PROPERTY AND CREDITOR; MUTUAL FUND INVESTMENT AND BROKERAGE SERVICES (U.S. CLS. 100, 101 AND 102).

KATINA MISTER, EXAMINING ATTORNEY

SN 77-603,235. NYSE GROUP INC., NEW YORK, NY. FILED 10-29-2008.

**NYSE MARKET FOCUS**

THE MARK CONSISTS OF STANDARD CHARACTERS WITHOUT CLAIM TO ANY PARTICULAR FONT, STYLE, SIZE, OR COLOR.

OWNER OF U.S. REG. NOS. 2,665,267, 3,482,197 AND OTHERS.

NO CLAIM IS MADE TO THE EXCLUSIVE RIGHT TO USE "MARKET", APART FROM THE MARK AS SHOWN.

FOR CONDUCTING A SECURITIES EXCHANGE AND PROVIDING RELATED SECURITIES EXCHANGE SERVICES, NAMELY, PROVIDING INFORMATION IN ELECTRONIC FORM REGARDING A SECURITIES MARKET AND SECURITIES TRADING ACTIVITY, PROVIDING FINANCIAL INFORMATION REGARDING PUBLICLY TRADED COMPANIES, TRADING ANALYSES FOR GIVEN COMPANIES, THEIR PEERS, AND THEIR RESPECTIVE MARKET SEGMENTS, UPDATES ON GLOBAL FINANCIAL MARKET INDICES, COMMODITIES, CURRENCIES AND NEWS REPORTING IN THE FIELD OF FINANCIAL NEWS, AND PROVIDING FINANCIAL INFORMATION AND FINANCIAL HISTORY INFORMATION ABOUT BUSINESSES VIA A GLOBAL COMPUTER NETWORK (U.S. CLS. 100, 101 AND 102).

FIRST USE 11-26-2007; IN COMMERCE 11-26-2007.

ELLEN PERKINS, EXAMINING ATTORNEY

**CLASS 36—(Continued).**

SN 77-687,331. THE LINCOLN NATIONAL LIFE INSURANCE COMPANY, FORT WAYNE, IN. FILED 3-10-2009.

**LINCOLN INREACH**

THE MARK CONSISTS OF STANDARD CHARACTERS WITHOUT CLAIM TO ANY PARTICULAR FONT, STYLE, SIZE, OR COLOR.

OWNER OF U.S. REG. NOS. 2,048,697, 3,372,211 AND OTHERS.

FOR INSURANCE SERVICES, NAMELY, UNDERWRITING, ISSUING AND ADMINISTRATION OF LIFE INSURANCE (U.S. CLS. 100, 101 AND 102).

FIRST USE 7-0-2009; IN COMMERCE 7-0-2009.

KATHERINE E. HALMEN, EXAMINING ATTORNEY

SN 77-864,895. FANNIE E. RIPPEL FOUNDATION, MORRISTOWN, NJ. FILED 11-4-2009.

**RIPPEL**

THE MARK CONSISTS OF STANDARD CHARACTERS WITHOUT CLAIM TO ANY PARTICULAR FONT, STYLE, SIZE, OR COLOR.

SEC. 2(F).

FOR CHARITABLE FOUNDATION SERVICES, NAMELY, PROVIDING FUND RAISING ACTIVITIES AND FINANCING TO SUPPORT RESEARCH IN THE FIELD OF HEALTH AND HEALTHCARE SYSTEMS, HEALTH AND HEALTHCARE PROCESSES, HEALTH AND HEALTHCARE PERCEPTIONS, HEALTH AND HEALTHCARE VALUES, HEALTH AND HEALTHCARE COSTS, HEALTH AND HEALTHCARE RESULTS, HEALTH AND HEALTHCARE ORGANIZATION; CHARITABLE FOUNDATION SERVICES, NAMELY, PROVIDING FUND RAISING ACTIVITIES AND FINANCING TO SUPPORT RESEARCH IN THE FIELD OF MEDICAL SYSTEMS, MEDICAL PROCESSES, MEDICAL PERCEPTIONS, MEDICAL VALUES, MEDICAL COSTS, MEDICAL RESULTS AND MEDICAL ORGANIZATION (U.S. CLS. 100, 101 AND 102).

FIRST USE 9-13-1994; IN COMMERCE 12-8-2003.

DAVID H. STINE, EXAMINING ATTORNEY

**CLASS 36—(Continued).**

SN 77-886,173. CHARLES SCHWAB & CO., INC., SAN FRANCISCO, CA. FILED 12-4-2009.

**MANAGED ACCOUNT CONNECTION**

THE MARK CONSISTS OF STANDARD CHARACTERS WITHOUT CLAIM TO ANY PARTICULAR FONT, STYLE, SIZE, OR COLOR.

OWNER OF U.S. REG. NOS. 2,671,375, 2,737,781 AND OTHERS.

NO CLAIM IS MADE TO THE EXCLUSIVE RIGHT TO USE "MANAGED ACCOUNT", APART FROM THE MARK AS SHOWN.

FOR FINANCIAL SERVICES PROVIDED TO INVESTORS, NAMELY, SECURITIES TRADING AND BROKERAGE SERVICES AND CUSTODY OF ASSETS; PROVIDING INVESTMENT PORTFOLIO MANAGEMENT SERVICES TO INVESTORS THROUGH THIRD PARTY ASSET MANAGEMENT AND INVESTMENT MANAGEMENT FIRMS; PROVIDING FINANCIAL AND INVESTMENT INFORMATION VIA A GLOBAL COMPUTER NETWORK (U.S. CLS. 100, 101 AND 102).

B. PARADEWELAI, EXAMINING ATTORNEY

SN 77-897,914. UNITED AMERICAN INSURANCE COMPANY, MCKINNEY, NE. FILED 12-21-2009.

**COMMON SENSE PLAN**

THE MARK CONSISTS OF STANDARD CHARACTERS WITHOUT CLAIM TO ANY PARTICULAR FONT, STYLE, SIZE, OR COLOR.

NO CLAIM IS MADE TO THE EXCLUSIVE RIGHT TO USE "PLAN", APART FROM THE MARK AS SHOWN.

FOR UNDERWRITING HEALTH INSURANCE (U.S. CLS. 100, 101 AND 102).

FIRST USE 3-0-1991; IN COMMERCE 3-0-1991.

NAKIA HENRY, EXAMINING ATTORNEY

SN 77-929,090. FLORIDA CREDIT UNION, GAINESVILLE, FL. FILED 2-5-2010.

**FLORIDA CREDIT UNION**

THE MARK CONSISTS OF STANDARD CHARACTERS WITHOUT CLAIM TO ANY PARTICULAR FONT, STYLE, SIZE, OR COLOR.

NO CLAIM IS MADE TO THE EXCLUSIVE RIGHT TO USE "CREDIT UNION", APART FROM THE MARK AS SHOWN.

SEC. 2(F).

FOR CREDIT UNIONS (U.S. CLS. 100, 101 AND 102).

FIRST USE 8-4-1988; IN COMMERCE 8-4-1988.

JIM RINGLE, EXAMINING ATTORNEY

**CLASS 36—(Continued).**

SN 77-929,125. FLORIDA CREDIT UNION, GAINESVILLE, FL. FILED 2-5-2010.

**FLORIDA CREDIT UNION  
ADVANTAGE CENTER**

THE MARK CONSISTS OF STANDARD CHARACTERS WITHOUT CLAIM TO ANY PARTICULAR FONT, STYLE, SIZE, OR COLOR.

NO CLAIM IS MADE TO THE EXCLUSIVE RIGHT TO USE "CREDIT UNION", APART FROM THE MARK AS SHOWN.

SEC. 2(F).

FOR CREDIT UNIONS (U.S. CLS. 100, 101 AND 102).

FIRST USE 12-0-1997; IN COMMERCE 12-0-1997.

JIM RINGLE, EXAMINING ATTORNEY

SN 77-939,109. HSBC HOLDINGS PLC, LONDON E14 5HQ, UNITED KINGDOM, FILED 2-18-2010.

**滙豐運籌理財**

OWNER OF U.S. REG. NOS. 2,000,657, 3,548,780 AND OTHERS.

NO CLAIM IS MADE TO THE EXCLUSIVE RIGHT TO USE THE NON-LATIN CHARACTERS THAT TRANSLITERATE TO "YUN CHOU LI CAI", APART FROM THE MARK AS SHOWN.

THE MARK CONSISTS OF TRADITIONAL CHINESE CHARACTERS.

THE CHARACTER "HUI FENG" HAS NO MEANING, THE CHARACTER "YUN CHOU" MEANS "PLANNING AND MANAGEMENT", AND THE CHARACTER "LI CAI" MEANS "MANAGING FINANCIAL MATTERS."

THE NON-LATIN CHARACTERS IN THE MARK TRANSLITERATE TO "HUI FENG", "YUN CHOU", AND "LI CAI."

FOR FINANCIAL SERVICES, NAMELY, FINANCIAL CONSULTANCY, FINANCIAL INFORMATION AND ADVISORY SERVICES, LENDING ON MORTGAGES, FINANCING OF LOANS, PROVIDING WORKING CAPITAL, BUSINESS FINANCE PROCUREMENT SERVICES, CREDIT BUREAUS AND CREDIT AGENCIES, ARRANGING AND PROVISION OF LOANS, MORTGAGES AND GUARANTEES; MONETARY AFFAIRS, NAMELY, CREDIT CARD, FOREIGN EXCHANGE AND BILL PAYMENT PROCESSING SERVICES, BANK CARD, CREDIT CARD, DEBIT CARD AND ELECTRONIC PAYMENT CARD SERVICES, CHEQUE CLEARING SERVICES, DEBT COLLECTION AND PAYMENT AGENCY, MONETARY EXCHANGE AND CURRENCY TRANSFER SERVICES, MONEY ORDER SERVICES, MONEY TRANSFER SERVICES, FOREIGN EXCHANGE TRANSACTIONS, SERVICES FOR THE PROVISION OF TRAVELLERS' CHEQUES, ELECTRONIC FUND TRANSFER SERVICES; REAL ESTATE AFFAIRS, NAMELY, REAL ESTATE AGENCY, MANAGEMENT AND VALUATION SERVICES, REAL PROPERTY MANAGEMENT SERVICE; INVESTMENT SERVICES, NAMELY, COMMODITY AND SECURITIES BROKERAGE, PENSION VALUATION, FINANCIAL ADMINISTRATION OF RETIREMENT PLANS, INVESTMENT

**CLASS 36—(Continued).**

FUND TRANSFER AND TRANSACTION SERVICES, INDIVIDUAL RETIREMENT ACCOUNT SERVICES, CAPITAL AND PRIVATE EQUITY INVESTMENT FUND MANAGEMENT SERVICES, FINANCIAL TRUST MANAGEMENT, TRUSTEE SERVICES, TRUSTEESHIP SERVICES, MANAGEMENT AND BROKERAGE IN THE FIELDS OF STOCKS, BONDS, OPTIONS, COMMODITIES, FUTURES AND OTHER SECURITIES, INVESTMENT ADVICE, INVESTMENT MANAGEMENT, INVESTMENT CONSULTATION AND INVESTMENT OF FUNDS FOR OTHERS, INCLUDING PRIVATE AND PUBLIC EQUITY AND DEBT INVESTMENT SERVICES, CAPITAL INVESTMENT SERVICES, INVESTMENT AND PROTECTION ADVICE, INVESTMENT MANAGEMENT SERVICES, FINANCIAL INVESTMENT SHARE VALUATION, NOMINATIVE AND REPRESENTATIVE SERVICES RELATING TO STOCKS, DIVIDENDS AND BONUS SHARES, FUNDS INVESTMENT, FINANCING SERVICES FOR SECURING FUNDS FOR INVESTMENT PURPOSES; INSURANCE SERVICES, NAMELY, INSURANCE BROKERAGE SERVICES, ANNUITY UNDERWRITING (U.S. CLS. 100, 101 AND 102).

ELLEN BURNS, EXAMINING ATTORNEY

SN 77-939,117. HSBC HOLDINGS PLC, LONDON E14 5HQ, UNITED KINGDOM, FILED 2-18-2010.

**汇丰运筹理财**

OWNER OF U.S. REG. NOS. 2,000,657, 3,548,780 AND OTHERS.

NO CLAIM IS MADE TO THE EXCLUSIVE RIGHT TO USE "YUN CHOU LI CAI", APART FROM THE MARK AS SHOWN.

THE MARK CONSISTS OF SIMPLIFIED CHINESE CHARACTERS.

THE CHARACTER "HUI FENG" HAS NO MEANING, THE CHARACTER "YUN CHOU" MEANS "PLANNING AND MANAGEMENT", AND THE CHARACTER "LI CAI" MEANS "MANAGING FINANCIAL MATTERS."

THE NON-LATIN CHARACTERS IN THE MARK TRANSLITERATE TO "HUI FENG", "YUN CHOU", AND "LI CAI."

FOR FINANCIAL SERVICES, NAMELY, FINANCIAL CONSULTANCY, FINANCIAL INFORMATION AND ADVISORY SERVICES, LENDING ON MORTGAGES, FINANCING OF LOANS, PROVIDING WORKING CAPITAL, BUSINESS FINANCE PROCUREMENT SERVICES, CREDIT BUREAUS AND CREDIT AGENCIES, ARRANGING AND PROVISION OF LOANS, MORTGAGES AND GUARANTEES; MONETARY AFFAIRS, NAMELY, CREDIT CARD, FOREIGN EXCHANGE AND BILL PAYMENT PROCESSING SERVICES, BANK CARD, CREDIT CARD, DEBIT CARD AND ELECTRONIC PAYMENT CARD SERVICES, CHEQUE CLEARING SERVICES, DEBT COLLECTION AND PAYMENT AGENCY, MONETARY EXCHANGE AND CURRENCY TRANSFER SERVICES, MONEY ORDER SERVICES, MONEY TRANSFER SERVICES, FOREIGN EXCHANGE TRANSACTIONS, SERVICES FOR THE PROVISION OF TRAVELLERS' CHEQUES, ELECTRONIC FUND TRANSFER SERVICES; REAL ESTATE AFFAIRS, NAMELY, REAL ESTATE AGENCY, MANAGEMENT AND VALUATION SERVICES, REAL PROPERTY MANAGEMENT SERVICE; INVESTMENT SERVICES, NAMELY, COMMODITY AND SECURITIES BROKERAGE, PENSION VALUATION, FINANCIAL ADMINISTRATION OF RETIREMENT PLANS, INVESTMENT FUND TRANSFER AND TRANSACTION SERVICES,

**CLASS 36—(Continued).**

INDIVIDUAL RETIREMENT ACCOUNT SERVICES, CAPITAL AND PRIVATE EQUITY INVESTMENT FUND MANAGEMENT SERVICES, FINANCIAL TRUST MANAGEMENT, TRUSTEE SERVICES, TRUSTEESHIP SERVICES, MANAGEMENT AND BROKERAGE IN THE FIELDS OF STOCKS, BONDS, OPTIONS, COMMODITIES, FUTURES AND OTHER SECURITIES, INVESTMENT ADVICE, INVESTMENT MANAGEMENT, INVESTMENT CONSULTATION AND INVESTMENT OF FUNDS FOR OTHERS, INCLUDING PRIVATE AND PUBLIC EQUITY AND DEBT INVESTMENT SERVICES, CAPITAL INVESTMENT SERVICES, INVESTMENT AND PROTECTION ADVICE, INVESTMENT MANAGEMENT SERVICES, FINANCIAL INVESTMENT SHARE VALUATION, NOMINATIVE AND REPRESENTATIVE SERVICES RELATING TO STOCKS, DIVIDENDS AND BONUS SHARES, FUNDS INVESTMENT, FINANCING SERVICES FOR SECURING FUNDS FOR INVESTMENT PURPOSES; INSURANCE SERVICES, NAMELY, INSURANCE BROKERAGE SERVICES, ANNUITY UNDERWRITING (U.S. CLS. 100, 101 AND 102).

ELLEN BURNS, EXAMINING ATTORNEY

---

SN 77-943,445. DIXIE STAMPEDE, LLC, PIGEON FORGE, TN. FILED 2-24-2010.

**GREAT CHOICE INVESTMENTS**

THE MARK CONSISTS OF STANDARD CHARACTERS WITHOUT CLAIM TO ANY PARTICULAR FONT, STYLE, SIZE, OR COLOR.

NO CLAIM IS MADE TO THE EXCLUSIVE RIGHT TO USE "INVESTMENTS", APART FROM THE MARK AS SHOWN.

FOR FINANCIAL SERVICES, NAMELY, FUNDING BUSINESSES IN THE FIELD OF ENTERTAINMENT (U.S. CLS. 100, 101 AND 102).

FIRST USE 5-27-2010; IN COMMERCE 5-27-2010.

C. DIONNE CLYBURN, EXAMINING ATTORNEY

---

SN 77-949,283. TUITION PLAN CONSORTIUM, LLC, ST. LOUIS, MO. FILED 3-3-2010.

**PRIVATE COLLEGE 529 PLAN  
TOMORROW'S TUITION AT  
TODAY'S PRICES GUARANTEED**

THE MARK CONSISTS OF STANDARD CHARACTERS WITHOUT CLAIM TO ANY PARTICULAR FONT, STYLE, SIZE, OR COLOR.

OWNER OF U.S. REG. NOS. 3,586,737 AND 3,590,685.

NO CLAIM IS MADE TO THE EXCLUSIVE RIGHT TO USE "PRIVATE COLLEGE 529 PLAN" AND "GUARANTEED", APART FROM THE MARK AS SHOWN.

FOR FINANCIAL SERVICES, NAMELY, MANAGING AND ADMINISTERING INVESTMENT PLANS FOR THE FUNDING OF HIGHER EDUCATION (U.S. CLS. 100, 101 AND 102).

FIRST USE 8-5-2010; IN COMMERCE 8-5-2010.

BERYL GARDNER, EXAMINING ATTORNEY

**CLASS 36—(Continued).**

SN 77-952,069. PAMLICO CAPITAL MANAGEMENT, LP, CHARLOTTE, NC. FILED 3-5-2010.

**PAMLICO CAPITAL**

THE MARK CONSISTS OF STANDARD CHARACTERS WITHOUT CLAIM TO ANY PARTICULAR FONT, STYLE, SIZE, OR COLOR.

NO CLAIM IS MADE TO THE EXCLUSIVE RIGHT TO USE "CAPITAL", APART FROM THE MARK AS SHOWN.

FOR MANAGEMENT OF PRIVATE EQUITY FUNDS AND HEDGE FUNDS; PRIVATE EQUITY FUND AND HEDGE FUND INVESTMENT SERVICES; FUND INVESTMENT CONSULTATION (U.S. CLS. 100, 101 AND 102).

MARILYN IZZI, EXAMINING ATTORNEY

---

SN 77-953,187. PAMLICO CAPITAL MANAGEMENT, LP, CHARLOTTE, NC. FILED 3-8-2010.



NO CLAIM IS MADE TO THE EXCLUSIVE RIGHT TO USE "CAPITAL", APART FROM THE MARK AS SHOWN.

THE MARK CONSISTS OF THE WORD "PAMLICO" APPEARING ABOVE THE WORD "CAPITAL" IN SMALLER TYPE ADJACENT TO A SQUARE SHAPED LOGO CONSISTING OF AN ILLUSTRATION OF A CONFLUENCE OF A GROUP OF RIVERS AND STREAMS.

FOR MANAGEMENT OF PRIVATE EQUITY FUNDS AND HEDGE FUNDS; PRIVATE EQUITY FUND AND HEDGE FUND INVESTMENT SERVICES; FUND INVESTMENT CONSULTATION (U.S. CLS. 100, 101 AND 102).

MARILYN IZZI, EXAMINING ATTORNEY

---

SN 77-953,474. WEST BEND MUTUAL INSURANCE COMPANY, WEST BEND, WI. FILED 3-8-2010.

**THE BEST REMEDY FOR  
WORKERS COMPENSATION**

THE MARK CONSISTS OF STANDARD CHARACTERS WITHOUT CLAIM TO ANY PARTICULAR FONT, STYLE, SIZE, OR COLOR.

NO CLAIM IS MADE TO THE EXCLUSIVE RIGHT TO USE "WORKERS COMPENSATION", APART FROM THE MARK AS SHOWN.

FOR INSURANCE SERVICES, NAMELY WRITING WORKERS COMPENSATION INSURANCE (U.S. CLS. 100, 101 AND 102).

BRIAN NEVILLE, EXAMINING ATTORNEY

**CLASS 36—(Continued).**

SN 77-962,725. CRYSTAL WORLD HOLDINGS, INC., WASHINGTON, DC. FILED 3-18-2010.

**SPORTSRISKINDEX**

THE MARK CONSISTS OF STANDARD CHARACTERS WITHOUT CLAIM TO ANY PARTICULAR FONT, STYLE, SIZE, OR COLOR.

FOR FINANCIAL SERVICES, NAMELY, PROVIDING EXCHANGE AND TRADING SERVICES FOR SPORTS-FOCUSED FINANCIAL INSTRUMENTS; PROVIDING INFORMATION REGARDING SPORTS-FOCUSED FINANCIAL INSTRUMENTS VIA THE INTERNET; PROVIDING AN ON-LINE COMPUTER DATABASE FEATURING EXCHANGE AND TRADE INFORMATION REGARDING SPORTS-FOCUSED FINANCIAL INSTRUMENTS (U.S. CLS. 100, 101 AND 102).

CAROLYN CATALDO, EXAMINING ATTORNEY

**CLASS 36—(Continued).**

SN 78-461,155. DUNDEE CORPORATION, TORONTO, ONTARIO, CANADA, FILED 8-3-2004.

**DUNDEE WEALTHCARE PRACTITIONER**

THE MARK CONSISTS OF STANDARD CHARACTERS WITHOUT CLAIM TO ANY PARTICULAR FONT, STYLE, SIZE, OR COLOR.

PRIORITY CLAIMED UNDER SEC. 44(D) ON CANADA APPLICATION NO. 1225028, FILED 7-27-2004, REG. NO. 776539, DATED 9-8-2010, EXPIRES 9-8-2025.

NO CLAIM IS MADE TO THE EXCLUSIVE RIGHT TO USE "WEALTHCARE", APART FROM THE MARK AS SHOWN.

FOR FINANCIAL PLANNING CONSULTING SERVICES, NAMELY, FINANCIAL PLANNING, FINANCIAL PLANNING ANALYSIS, ASSET ALLOCATION ANALYSIS, RETIREMENT PLANNING, ESTATE PLANNING AND PROVIDING PORTFOLIO RECOMMENDATIONS AND A DETAILED PERSONALIZED INVESTMENT STRATEGY (U.S. CLS. 100, 101 AND 102).

BARBARA BROWN, EXAMINING ATTORNEY

SN 77-969,458. TANGO CARD, INC., SEATTLE, WA. FILED 3-26-2010.



THE MARK CONSISTS OF THE LETTERS "T" AND "C" BISECTING EACH OTHER VERTICALLY, ENCIRCLED BY TWELVE RECTANGULAR OBJECTS SHAPED LIKE GIFT CARDS.

FOR PROVIDING ONLINE STORED VALUE CARD SERVICES (U.S. CLS. 100, 101 AND 102).

FIRST USE 8-31-2009; IN COMMERCE 8-31-2009.

DAVID ELTON, EXAMINING ATTORNEY

SN 79-075,774. ALTHEA CAPITAL LLP, UNITED KINGDOM, FILED 11-11-2009.

**ALTHEA**

THE MARK CONSISTS OF STANDARD CHARACTERS WITHOUT CLAIM TO ANY PARTICULAR FONT, STYLE, SIZE, OR COLOR.

PRIORITY DATE OF 9-17-2009 IS CLAIMED.

OWNER OF INTERNATIONAL REGISTRATION 1020681 DATED 11-11-2009, EXPIRES 11-11-2019.

FOR INVESTMENT AND FINANCIAL MANAGEMENT SERVICES, NAMELY, HEDGE FUND MANAGEMENT SERVICES (U.S. CLS. 100, 101 AND 102).

HANNO RITTNER, EXAMINING ATTORNEY

**CLASS 36—(Continued).**

SN 79-077,236. INTESA SANPAOLO S.P.A., ITALY, FILED 11-5-2009.



PRIORITY DATE OF 10-13-2009 IS CLAIMED.  
OWNER OF INTERNATIONAL REGISTRATION 1024680  
DATED 11-5-2009, EXPIRES 11-5-2019.

THE MARK CONSISTS OF THE WORDING "IN BIZ" WITH A LINE CURVING BETWEEN THE TWO WORDS.

FOR BANKING SERVICES; INVESTMENT BANKING SERVICES; FINANCIAL SERVICES IN THE NATURE OF UNDERWRITING, DISTRIBUTION, AND TRADING OF SECURITIES; FINANCIAL SERVICES IN THE NATURE OF FINANCING CORPORATE ACTIVITIES; SECURITIES BROKERAGE SERVICES; FINANCIAL INVESTMENT RESEARCH SERVICES; INVESTMENT MANAGEMENT AND ADVICE; FINANCIAL SERVICES IN THE NATURE OF TRADING FUTURES, CURRENCIES, OPTIONS, FOREIGN EXCHANGE, AND COMMODITIES; MONETARY CLEARANCE SERVICES, NAMELY, FINANCIAL CLEARING HOUSES; SECURITIES AND MUTUAL FUND CUSTODY SERVICES, NAMELY, SECURITIES AND MUTUAL FUND BROKERAGE; ESTATE PLANNING SERVICES; REAL ESTATE TRUSTEE SERVICES; PENSION ADMINISTRATION SERVICES; MUTUAL FUND BROKERAGE, INVESTMENT, DISTRIBUTION AND ESTABLISHING MUTUAL FUNDS FOR OTHERS; DERIVATIVE INVESTMENT SECURITIES; FINANCIAL RISK MANAGEMENT SERVICES; INSURANCE INVESTMENT SECURITIES CONSULTING; INSURANCE BROKERAGE, INSURANCE ADMINISTRATION IN THE FIELDS OF HOME, VEHICLE, LIFE, ACCIDENT, PERSONAL LIABILITY INSURANCE; FINANCIAL PLANNING SERVICES; CREDIT CARD SERVICES AND CREDIT CARD BENEFIT SERVICES, NAMELY, CREDIT CARD INSURANCE; DEBIT CARD SERVICES AND DEBIT CARD BENEFIT SERVICES, NAMELY, TRAVEL ACCIDENT INSURANCE SERVICES; CHECK CARD SERVICES AND CHECK CARD BENEFIT SERVICES, NAMELY, TRAVEL ACCIDENT INSURANCE SERVICES; REAL ESTATE AGENCY, VALUATION, NAMELY, FINANCIAL VALUATION OF PERSONAL PROPERTY AND REAL ESTATE, AND REAL ESTATE MANAGEMENT AND BROKERAGE (U.S. CLS. 100, 101 AND 102).

AISHA CLARKE, EXAMINING ATTORNEY

**CLASS 36—(Continued).**

SN 79-077,237. INTESA SANPAOLO S.P.A., ITALY, FILED 11-5-2009.

# IN BIZ

THE MARK CONSISTS OF STANDARD CHARACTERS WITHOUT CLAIM TO ANY PARTICULAR FONT, STYLE, SIZE, OR COLOR.

PRIORITY DATE OF 10-13-2009 IS CLAIMED.  
OWNER OF INTERNATIONAL REGISTRATION 1024681  
DATED 11-5-2009, EXPIRES 11-5-2019.

FOR BANKING SERVICES; INVESTMENT BANKING SERVICES; FINANCIAL SERVICES IN THE NATURE OF UNDERWRITING, DISTRIBUTION, AND TRADING OF SECURITIES; FINANCIAL SERVICES IN THE NATURE OF FINANCING CORPORATE ACTIVITIES; SECURITIES BROKERAGE SERVICES; FINANCIAL INVESTMENT RESEARCH SERVICES; INVESTMENT MANAGEMENT AND ADVICE; FINANCIAL SERVICES IN THE NATURE OF TRADING FUTURES, CURRENCIES, OPTIONS, FOREIGN EXCHANGE, AND COMMODITIES; MONETARY CLEARANCE SERVICES, NAMELY, FINANCIAL CLEARING HOUSES; SECURITIES AND MUTUAL FUND CUSTODY SERVICES, NAMELY, SECURITIES AND MUTUAL FUND BROKERAGE; ESTATE PLANNING SERVICES; REAL ESTATE TRUSTEE SERVICES; PENSION ADMINISTRATION SERVICES; MUTUAL FUND BROKERAGE, INVESTMENT, DISTRIBUTION AND ESTABLISHING MUTUAL FUNDS FOR OTHERS; DERIVATIVE INVESTMENT SECURITIES; FINANCIAL RISK MANAGEMENT SERVICES; INSURANCE INVESTMENT SECURITIES CONSULTING; INSURANCE BROKERAGE, INSURANCE ADMINISTRATION IN THE FIELDS OF HOME, VEHICLE, LIFE, ACCIDENT, PERSONAL LIABILITY INSURANCE; FINANCIAL PLANNING SERVICES; CREDIT CARD SERVICES AND CREDIT CARD BENEFIT SERVICES, NAMELY, CREDIT CARD INSURANCE; DEBIT CARD SERVICES AND DEBIT CARD BENEFIT SERVICES, NAMELY, TRAVEL ACCIDENT INSURANCE SERVICES; CHECK CARD SERVICES AND CHECK CARD BENEFIT SERVICES, NAMELY, TRAVEL ACCIDENT INSURANCE SERVICES; REAL ESTATE AGENCY, VALUATION, NAMELY, FINANCIAL VALUATION OF PERSONAL PROPERTY AND REAL ESTATE, AND REAL ESTATE MANAGEMENT AND BROKERAGE (U.S. CLS. 100, 101 AND 102).

AISHA CLARKE, EXAMINING ATTORNEY



**CLASS 36—(Continued).**

SN 85-004,636. THE MCGRAW COMPANY, DBA MCGRAW INSURANCE SERVICES, THE MCGRAW GROUP OF AFFILIATED COMPANIES, THE MCGRAW COMMERCIAL INSURANCE SERVICES, MCGRAW SPECIALTY INSURANCE SERVICES, MENLO PARK, CA. FILED 4-1-2010.



NO CLAIM IS MADE TO THE EXCLUSIVE RIGHT TO USE "POWERSPORTS GROUP", APART FROM THE MARK AS SHOWN.

THE MARK CONSISTS OF A SHIELD, HAVING THREE UPWARD POINTING APEXES ON THE TOP AND A SINGLE APEX POINTING DOWNWARD ON THE BOTTOM, WITH THE INSCRIPTION "MCGRAW POWERSPORTS GROUP".

FOR INSURANCE SERVICES, NAMELY, UNDERWRITING CLAIMS ADMINISTRATION AND AGENCY SERVICES FOR CASUALTY, AUTOMOBILE, MOTORCYCLE AND WATERCRAFT INSURANCE (U.S. CLS. 100, 101 AND 102).

JANET LEE, EXAMINING ATTORNEY



SN 85-016,239. LCS RECEIVABLES MANAGEMENT, LLC, ENGLEWOOD, CO. FILED 4-16-2010.

**SPANNING THE RECOVERY SPECTRUM**

THE MARK CONSISTS OF STANDARD CHARACTERS WITHOUT CLAIM TO ANY PARTICULAR FONT, STYLE, SIZE, OR COLOR.

FOR FINANCIAL SERVICES, NAMELY, LOAN ORIGINATION, LOAN SERVICING, STAGED DEBT COLLECTION AND LOSS MITIGATION SERVICES FOR UNDER OR NON-PERFORMING MORTGAGE LOANS, SECOND MORTGAGES AND HOME EQUITY LOANS, MORTGAGE REFINANCING, PORTFOLIO PRICING, NAMELY, FINANCIAL PORTFOLIO MANAGEMENT, DEBT ACQUISITION AND SALES, NAMELY, DEBT COLLECTION AND SETTLEMENT (U.S. CLS. 100, 101 AND 102).

LANA PHAM, EXAMINING ATTORNEY

**CLASS 36—(Continued).**

SN 85-016,252. LCS RECEIVABLES MANAGEMENT, LLC, ENGLEWOOD, CO. FILED 4-16-2010.



THE MARK CONSISTS OF A WHEEL DESIGN. FOR FINANCIAL SERVICES, NAMELY, LOAN ORIGINATION, LOAN SERVICING, STAGED DEBT COLLECTION AND LOSS MITIGATION SERVICES FOR UNDER OR NON-PERFORMING MORTGAGE LOANS, SECOND MORTGAGES AND HOME EQUITY LOANS, MORTGAGE REFINANCING, PORTFOLIO PRICING, NAMELY, FINANCIAL PORTFOLIO MANAGEMENT, DEBT ACQUISITION AND SALES, NAMELY, DEBT COLLECTION AND SETTLEMENT (U.S. CLS. 100, 101 AND 102).

LANA PHAM, EXAMINING ATTORNEY



SN 85-020,449. GFI GROUP INC., NEW YORK, NY. FILED 4-22-2010.

**MODENA SECURITIES**

THE MARK CONSISTS OF STANDARD CHARACTERS WITHOUT CLAIM TO ANY PARTICULAR FONT, STYLE, SIZE, OR COLOR.

NO CLAIM IS MADE TO THE EXCLUSIVE RIGHT TO USE "SECURITIES", APART FROM THE MARK AS SHOWN.

FOR BROKERAGE SERVICES IN THE FIELD OF EQUITIES AND SECURITIES TRADING; FINANCIAL MANAGEMENT; INVESTMENT MANAGEMENT; FINANCIAL AND INVESTMENT SERVICES, NAMELY, PROVIDING PRICING, MARKET AND TRADING INFORMATION FOR EQUITIES AND SECURITIES BY GLOBAL COMPUTER NETWORK FOR USE BY FINANCIAL INSTITUTIONS, PROFESSIONALS, AND TRADERS; EXECUTION OF TRANSACTIONS INVOLVING EQUITIES AND SECURITIES VIA GLOBAL COMPUTER NETWORK FOR USE BY FINANCIAL INSTITUTIONS, PROFESSIONALS AND TRADERS (U.S. CLS. 100, 101 AND 102).

DARRYL SPRUILL, EXAMINING ATTORNEY

**CLASS 36—(Continued).**

SN 85-023,791. PROPERTY HUB REALTY LLC, NORTH ARLINGTONTON, NJ. FILED 4-27-2010.



NO CLAIM IS MADE TO THE EXCLUSIVE RIGHT TO USE "PROPERTY" AND "REALTY LLC", APART FROM THE MARK AS SHOWN.

THE COLOR(S) GREEN, WHITE AND BLACK IS/ARE CLAIMED AS A FEATURE OF THE MARK.

THE MARK CONSISTS OF A RECTANGLE WITH A WHITE AND BLACK COLOR OUTLINE; TWO VERTICAL BARS IN GREEN COLOR AND A WHITE COLOR BAR IN THE MIDDLE AND A REAL ESTATE BROKERAGE SIGN IN BLACK COLOR; WHEREIN THE WORDS "PROPERTY HUB" IS WRITTEN IN GREEN COLOR ON THE WHITE COLOR BAR IN THE MIDDLE OF THE RECTANGLE AND "REALTY LLC" IS WRITTEN BELOW THE WORD "HUB" IN BLACK COLOR. THE LINING SHOWN IN THE DRAWING IS A FEATURE OF THE MARK.

FOR INSURANCE AND FINANCIAL SERVICES, NAMELY, REAL ESTATE SERVICES; PROVIDING OF SERVICES TO LEASE OF RESIDENTIAL AND COMMERCIAL REAL ESTATE FOR CONSUMERS; REAL ESTATE BROKERAGE AND LISTING OF RESIDENTIAL AND COMMERCIAL REAL ESTATE FOR CONSUMERS (U.S. CLS. 100, 101 AND 102).

NAKIA HENRY, EXAMINING ATTORNEY

SN 85-027,282. AHNTECH, INC., SAN DIEGO, CA. FILED 4-30-2010.

# NETKEY

THE MARK CONSISTS OF STANDARD CHARACTERS WITHOUT CLAIM TO ANY PARTICULAR FONT, STYLE, SIZE, OR COLOR.

FOR LEASING OF ELECTRONIC CREDIT CARD AND DEBIT CARD PROCESSING MACHINES (U.S. CLS. 100, 101 AND 102).

FIRST USE 3-1-1996; IN COMMERCE 3-1-1996.

LAURIE KAUFMAN, EXAMINING ATTORNEY

**CLASS 36—(Continued).**

SN 85-027,471. BESTHOMEHEALTHCARE.COM INC., CLEVELAND, OH. FILED 4-30-2010.

# CARINGCREDITS

THE MARK CONSISTS OF STANDARD CHARACTERS WITHOUT CLAIM TO ANY PARTICULAR FONT, STYLE, SIZE, OR COLOR.

FOR CHARITABLE FUNDRAISING (U.S. CLS. 100, 101 AND 102).

FIRST USE 4-27-2010; IN COMMERCE 4-27-2010.

REBECCA POVARCHUK, EXAMINING ATTORNEY

SN 85-035,552. NORTHRIM BANCORP, INC., ANCHORAGE, AK. FILED 5-11-2010.

# NORTHRIM BANK

THE MARK CONSISTS OF STANDARD CHARACTERS WITHOUT CLAIM TO ANY PARTICULAR FONT, STYLE, SIZE, OR COLOR.

NO CLAIM IS MADE TO THE EXCLUSIVE RIGHT TO USE "BANK", APART FROM THE MARK AS SHOWN.

FOR PERSONAL, SMALL BUSINESS AND COMMERCIAL BANKING SERVICES; ONLINE PERSONAL, SMALL BUSINESS AND COMMERCIAL BANKING SERVICES; FINANCIAL SERVICES, NAMELY, LOANS SERVICES AND COMMERCIAL AND CONSUMER LENDING SERVICES; BANKING SERVICES, NAMELY, CERTIFICATE OF DEPOSIT ACCOUNT SERVICES; FINANCIAL INVESTMENT BROKERAGE SERVICES (U.S. CLS. 100, 101 AND 102).

FIRST USE 5-31-1990; IN COMMERCE 12-4-1990.

BILL DAWE, EXAMINING ATTORNEY

SN 85-045,206. ING DIRECT BANCORP, WILMINGTON, DE. FILED 5-21-2010.

# THERE'S NO SUCH THING AS SAVER'S REMORSE.

THE MARK CONSISTS OF STANDARD CHARACTERS WITHOUT CLAIM TO ANY PARTICULAR FONT, STYLE, SIZE, OR COLOR.

FOR BANKING SERVICES; ON-LINE BANKING SERVICES (U.S. CLS. 100, 101 AND 102).

MIDGE BUTLER, EXAMINING ATTORNEY

**CLASS 36—(Continued).**

SN 85-046,316. RODGERS INSURANCE GROUP, PITTSBURGH, PA. FILED 5-24-2010.

RODGERS INSURANCE GROUP

THE MARK CONSISTS OF STANDARD CHARACTERS WITHOUT CLAIM TO ANY PARTICULAR FONT, STYLE, SIZE, OR COLOR.

NO CLAIM IS MADE TO THE EXCLUSIVE RIGHT TO USE "INSURANCE GROUP", APART FROM THE MARK AS SHOWN.

SEC. 2(F).  
FOR BROKERAGE IN THE FIELD OF INSURANCE (U.S. CLS. 100, 101 AND 102).

FIRST USE 4-4-2003; IN COMMERCE 3-26-2004.  
KATHERINE CONNOLLY, EXAMINING ATTORNEY

**CLASS 36—(Continued).**

SN 85-060,363. VICEROY PARTNERS, NEW YORK, NY. FILED 6-11-2010.

"Viceroy Net Worth Analytics"

THE MARK CONSISTS OF STANDARD CHARACTERS WITHOUT CLAIM TO ANY PARTICULAR FONT, STYLE, SIZE, OR COLOR.

OWNER OF U.S. REG. NO. 3,834,085.  
NO CLAIM IS MADE TO THE EXCLUSIVE RIGHT TO USE "NET WORTH ANALYTICS", APART FROM THE MARK AS SHOWN.

FOR FINANCIAL CONSULTING SERVICES, NAMELY, EXPERT ANALYSIS IN FINANCE (U.S. CLS. 100, 101 AND 102).

HANNO RITTNER, EXAMINING ATTORNEY

SN 85-054,098. BOOKS BEHIND BARS AND BEYOND, MORRISTOWN, NJ. FILED 6-3-2010.

BOOKS BEHIND BARS & BEYOND

THE MARK CONSISTS OF STANDARD CHARACTERS WITHOUT CLAIM TO ANY PARTICULAR FONT, STYLE, SIZE, OR COLOR.

FOR ACCEPTING AND ADMINISTERING MONETARY CHARITABLE CONTRIBUTIONS (U.S. CLS. 100, 101 AND 102).

FIRST USE 12-31-2003; IN COMMERCE 12-31-2003.  
KEVIN CORWIN, EXAMINING ATTORNEY

SN 85-065,316. FEDERAL HOME LOAN MORTGAGE CORPORATION, MCLEAN, VA. FILED 6-17-2010.

UCDP

THE MARK CONSISTS OF STANDARD CHARACTERS WITHOUT CLAIM TO ANY PARTICULAR FONT, STYLE, SIZE, OR COLOR.

FOR FINANCIAL AND REAL ESTATE SERVICES, NAMELY, PROVIDING AN INTERNET WEBSITE PORTAL OFFERING AN ELECTRONIC INTERFACE FOR THE COLLECTION OF RESIDENTIAL APPRAISAL DATA (U.S. CLS. 100, 101 AND 102).

BARBARA RUTLAND, EXAMINING ATTORNEY

SN 85-060,359. VICEROY PARTNERS, NEW YORK, NY. FILED 6-11-2010.

"Viceroy Net Worth Analysis"

THE MARK CONSISTS OF STANDARD CHARACTERS WITHOUT CLAIM TO ANY PARTICULAR FONT, STYLE, SIZE, OR COLOR.

OWNER OF U.S. REG. NO. 3,834,085.  
NO CLAIM IS MADE TO THE EXCLUSIVE RIGHT TO USE "NET WORTH ANALYSIS", APART FROM THE MARK AS SHOWN.

FOR FINANCIAL CONSULTING SERVICES, NAMELY, EXPERT ANALYSIS IN FINANCE (U.S. CLS. 100, 101 AND 102).

HANNO RITTNER, EXAMINING ATTORNEY

SN 85-065,743. FEDERAL RESERVE BANKS, CHICAGO, IL. FILED 6-17-2010.

WIRED TO DELIVER

THE MARK CONSISTS OF STANDARD CHARACTERS WITHOUT CLAIM TO ANY PARTICULAR FONT, STYLE, SIZE, OR COLOR.

FOR TRANSFER OF FUNDS AND SECURITIES BETWEEN DEPOSITORY INSTITUTIONS (U.S. CLS. 100, 101 AND 102).

JANET LEE, EXAMINING ATTORNEY

**CLASS 36—(Continued).**

SN 85-066,211. ACCESS TO MONEY, INC., CHERRY HILL, NJ. FILED 6-18-2010.

**PSL ADVANTAGE**

THE MARK CONSISTS OF STANDARD CHARACTERS WITHOUT CLAIM TO ANY PARTICULAR FONT, STYLE, SIZE, OR COLOR.

NO CLAIM IS MADE TO THE EXCLUSIVE RIGHT TO USE "PSL", APART FROM THE MARK AS SHOWN.

FOR ELECTRONIC PRIVATE STUDENT LOAN ORIGINATION SERVICES (U.S. CLS. 100, 101 AND 102).  
ALEXANDER L. POWERS, EXAMINING ATTORNEY

---

SN 85-079,585. SUTTON BANK, ATTICA, OH. FILED 7-7-2010.

**SUTTON AGENCY**

THE MARK CONSISTS OF STANDARD CHARACTERS WITHOUT CLAIM TO ANY PARTICULAR FONT, STYLE, SIZE, OR COLOR.

OWNER OF U.S. REG. NO. 3,016,166.

NO CLAIM IS MADE TO THE EXCLUSIVE RIGHT TO USE "AGENCY", APART FROM THE MARK AS SHOWN.  
SEC. 2(F).

FOR INSURANCE BROKERAGE IN THE FIELDS OF GENERAL LIFE, HEALTH, PROPERTY AND CASUALTY INSURANCE; ISSUANCE AND ADMINISTRATION OF ANNUITIES (U.S. CLS. 100, 101 AND 102).

FIRST USE 12-0-2009; IN COMMERCE 12-0-2009.  
ELLEN BURNS, EXAMINING ATTORNEY

---

SN 85-079,596. SUTTON BANK, ATTICA, OH. FILED 7-7-2010.



OWNER OF U.S. REG. NO. 3,016,166.

NO CLAIM IS MADE TO THE EXCLUSIVE RIGHT TO USE "AGENCY", APART FROM THE MARK AS SHOWN.

THE MARK CONSISTS OF AN S-SHAPED ROAD DESIGN TO THE LEFT OF THE WORDS "SUTTON AGENCY", WITH THE WORD "AGENCY" IN ITALICIZED FONT.

FOR INSURANCE BROKERAGE IN THE FIELDS OF GENERAL LIFE, HEALTH, PROPERTY AND CASUALTY INSURANCE; ISSUANCE AND ADMINISTRATION OF ANNUITIES (U.S. CLS. 100, 101 AND 102).

FIRST USE 12-0-2009; IN COMMERCE 12-0-2009.  
ELLEN BURNS, EXAMINING ATTORNEY

**CLASS 36—(Continued).**

SN 85-087,476. UTICA MUTUAL INSURANCE COMPANY, DBA UTICA NATIONAL INSURANCE GROUP, NEW HARTFORD, NY. FILED 7-19-2010.

**Agency Ally e&o PROGRAM**

THE MARK CONSISTS OF STANDARD CHARACTERS WITHOUT CLAIM TO ANY PARTICULAR FONT, STYLE, SIZE, OR COLOR.

NO CLAIM IS MADE TO THE EXCLUSIVE RIGHT TO USE "AGENCY" AND "E&O PROGRAM", APART FROM THE MARK AS SHOWN.

FOR INSURANCE SERVICES, NAMELY, UNDERWRITING IN THE FIELD OF ERRORS AND OMISSIONS INSURANCE AND MALPRACTICE INSURANCE (U.S. CLS. 100, 101 AND 102).

FIRST USE 6-22-2010; IN COMMERCE 6-22-2010.  
ROBERT C. CLARK JR., EXAMINING ATTORNEY

---

SN 85-090,368. FARMERS AUTOMOBILE MANAGEMENT CORPORATION, AKA PEKIN INSURANCE, PEKIN, IL. FILED 7-22-2010.

**Pekin Insurance**

THE MARK CONSISTS OF STANDARD CHARACTERS WITHOUT CLAIM TO ANY PARTICULAR FONT, STYLE, SIZE, OR COLOR.

NO CLAIM IS MADE TO THE EXCLUSIVE RIGHT TO USE "INSURANCE", APART FROM THE MARK AS SHOWN.

SEC. 2(F).

FOR INSURANCE UNDERWRITING IN THE FIELD OF LIFE, HOME, AND AUTOMOBILE INSURANCE FOR INDIVIDUALS AND BUSINESSES (U.S. CLS. 100, 101 AND 102).

FIRST USE 6-1-1934; IN COMMERCE 6-1-1934.  
JOHN DWYER, EXAMINING ATTORNEY

**CLASS 36—(Continued).**

SN 85-091,288. BANKUNITED, INC., MIAMI LAKES, FL. FILED 7-23-2010.

**CLASS 36—(Continued).**

SN 85-102,193. BANKUNITED, INC., MIAMI LAKES, FL. FILED 8-6-2010.

**PINNACLE PUBLIC FINANCE**



THE MARK CONSISTS OF STANDARD CHARACTERS WITHOUT CLAIM TO ANY PARTICULAR FONT, STYLE, SIZE, OR COLOR.

NO CLAIM IS MADE TO THE EXCLUSIVE RIGHT TO USE "PUBLIC FINANCE", APART FROM THE MARK AS SHOWN.

FOR FINANCING SERVICES, NAMELY, PROVIDING TAX EXEMPT FINANCING TO MUNICIPALITIES AND GOVERNMENTAL ENTITIES FOR ASSETS SUCH AS COMPUTER HARDWARE AND SOFTWARE, TELECOMMUNICATION SYSTEMS, ENERGY MANAGEMENT SYSTEMS AND MUNICIPAL VEHICLE FLEETS (U.S. CLS. 100, 101 AND 102).

BRIDGETT SMITH, EXAMINING ATTORNEY

NO CLAIM IS MADE TO THE EXCLUSIVE RIGHT TO USE "CAPITAL BUSINESS LENDING", APART FROM THE MARK AS SHOWN.

THE MARK CONSISTS OF RAISED COLUMNS TO THE LEFT OF THE WORDING "UNITED CAPITAL BUSINESS LENDING".

FOR FINANCING AND LOAN SERVICES, NAMELY, LOANS AND LEASE FINANCING TO SMALL BUSINESSES; FINANCING SERVICES FOR EQUIPMENT PURCHASES, BUSINESS ACQUISITIONS, EXPANSION AND REFINANCING EXISTING DEBT; FINANCING SERVICES FOR UPPER TIER FRANCHISE OPERATORS REQUIRING FINANCING FOR NEW LOCATIONS, RENOVATIONS AND ACQUISITIONS (U.S. CLS. 100, 101 AND 102).

BRIDGETT SMITH, EXAMINING ATTORNEY

SN 85-102,081. THE MADTRAVELERS FOUNDATION, BROOKLYN, NY. FILED 8-6-2010.



SN 85-115,501. RED REEF PARTNERS, L.L.C., BOCA RATON, FL. FILED 8-25-2010.

**RED REEF**

NO CLAIM IS MADE TO THE EXCLUSIVE RIGHT TO USE "FOUNDATION", APART FROM THE MARK AS SHOWN.

THE COLOR(S) BLUE, BLACK, AND ORANGE IS/ARE CLAIMED AS A FEATURE OF THE MARK.

THE MARK CONSISTS OF THE LETTERS "M", "A", "D" IN BLUE, THE LETTERS "T", "R", "A", "V", "E", "L", "E", "R", "S" IN BLACK, AND THE LETTERS "F", "O", "U", "N", "D", "A", "T", "I", "O", "N" IN ORANGE.

FOR CHARITABLE FUNDRAISING SERVICES, NAMELY, RAISING FUNDS FOR COLLEGE EDUCATION COSTS; PROVIDING COLLEGE SCHOLARSHIPS (U.S. CLS. 100, 101 AND 102).

LINDSEY RUBIN, EXAMINING ATTORNEY

THE MARK CONSISTS OF STANDARD CHARACTERS WITHOUT CLAIM TO ANY PARTICULAR FONT, STYLE, SIZE, OR COLOR.

FOR PRIVATE EQUITY SERVICES, NAMELY, PRIVATE EQUITY FUND INVESTMENT SERVICES, PRIVATE EQUITY CONSULTANT SERVICES, AND MANAGEMENT OF PRIVATE EQUITY FUNDS; INVESTMENT MANAGEMENT SERVICES (U.S. CLS. 100, 101 AND 102).

JAY BESCH, EXAMINING ATTORNEY

**CLASS 36—(Continued).**

SN 85-115,507. RED REEF PARTNERS, L.L.C., BOCA RATON, FL. FILED 8-25-2010.

**RED REEF PARTNERS**

THE MARK CONSISTS OF STANDARD CHARACTERS WITHOUT CLAIM TO ANY PARTICULAR FONT, STYLE, SIZE, OR COLOR.

NO CLAIM IS MADE TO THE EXCLUSIVE RIGHT TO USE "PARTNERS", APART FROM THE MARK AS SHOWN. FOR PRIVATE EQUITY SERVICES, NAMELY, PRIVATE EQUITY FUND INVESTMENT SERVICES, PRIVATE EQUITY CONSULTANT SERVICES, AND MANAGEMENT OF PRIVATE EQUITY FUNDS; INVESTMENT MANAGEMENT SERVICES (U.S. CLS. 100, 101 AND 102).

JAY BESCH, EXAMINING ATTORNEY

SN 85-128,032. LIBERTAD BANK SSB, AUSTIN, TX. FILED 9-13-2010.

**Homevantage Capital**

THE MARK CONSISTS OF STANDARD CHARACTERS WITHOUT CLAIM TO ANY PARTICULAR FONT, STYLE, SIZE, OR COLOR.

NO CLAIM IS MADE TO THE EXCLUSIVE RIGHT TO USE "CAPITAL", APART FROM THE MARK AS SHOWN. FOR BANKING AND FINANCING SERVICES (U.S. CLS. 100, 101 AND 102).

ANNE FARRELL, EXAMINING ATTORNEY

SN 85-129,623. PINNACLE ENTERTAINMENT, INC., LAS VEGAS, NV. FILED 9-14-2010.

**PINNACLE ENTERTAINMENT  
FOUNDATION**

THE MARK CONSISTS OF STANDARD CHARACTERS WITHOUT CLAIM TO ANY PARTICULAR FONT, STYLE, SIZE, OR COLOR.

NO CLAIM IS MADE TO THE EXCLUSIVE RIGHT TO USE "ENTERTAINMENT FOUNDATION", APART FROM THE MARK AS SHOWN.

FOR ACCEPTING AND ADMINISTERING MONETARY CHARITABLE CONTRIBUTIONS; CHARITABLE FUNDRAISING; PHILANTHROPIC SERVICES CONCERNING MONETARY DONATIONS (U.S. CLS. 100, 101 AND 102).

SKYE YOUNG, EXAMINING ATTORNEY

**CLASS 36—(Continued).**

SN 85-130,915. SUN LIFE ASSURANCE COMPANY OF CANADA, TORONTO, ONTARIO, CANADA, FILED 9-16-2010.

**SUN INCOME VISION**

THE MARK CONSISTS OF STANDARD CHARACTERS WITHOUT CLAIM TO ANY PARTICULAR FONT, STYLE, SIZE, OR COLOR.

OWNER OF U.S. REG. NOS. 2,494,662, 3,854,703 AND OTHERS.

NO CLAIM IS MADE TO THE EXCLUSIVE RIGHT TO USE "INCOME", APART FROM THE MARK AS SHOWN. FOR UNDERWRITING, ISSUING AND ADMINISTRATION OF ANNUITIES (U.S. CLS. 100, 101 AND 102).

DAVID ELTON, EXAMINING ATTORNEY

SN 85-131,271. LIBERTY MUTUAL AGENCY CORPORATION, BOSTON, MA. FILED 9-16-2010.

**eCLIQ**

THE MARK CONSISTS OF STANDARD CHARACTERS WITHOUT CLAIM TO ANY PARTICULAR FONT, STYLE, SIZE, OR COLOR.

FOR INSURANCE SERVICES, NAMELY, INSURANCE UNDERWRITING SERVICES FOR ALL TYPES OF INSURANCE; INSURANCE INFORMATION SERVICES; ONLINE INSURANCE INFORMATION SERVICES; INSURANCE CONSULTING SERVICES; ONLINE PROCESSING OF INSURANCE QUOTES (U.S. CLS. 100, 101 AND 102).

FIRST USE 9-3-2010; IN COMMERCE 9-3-2010.

WANDA KAY PRICE, EXAMINING ATTORNEY

SN 85-133,407. HARDING, RICHARD, SAN FRANCISCO, CA. FILED 9-20-2010.

**ARMOR**

THE MARK CONSISTS OF STANDARD CHARACTERS WITHOUT CLAIM TO ANY PARTICULAR FONT, STYLE, SIZE, OR COLOR.

FOR FINANCIAL SERVICES, NAMELY, FINANCIAL MANAGEMENT, LOAN FINANCING; FINANCIAL AND FISCAL APPRAISAL SERVICES, NAMELY, APPRAISING POTENTIAL INVESTORS AS TO RECOMMENDED LEVEL OF RISK TO TAKE IN INVESTMENT PRODUCTS; FINANCIAL INVESTMENT AND INVESTMENT SERVICES, NAMELY, INVESTMENT FUND MANAGEMENT, UNIT TRUST SERVICES AND INVESTMENT TRUST SERVICES; PENSION FUND SERVICES, NAMELY, ADMINISTRATION OF EMPLOYEE PENSION PLANS, PROVIDING INFORMATION AND ADVICE IN RELATION TO PENSION SCHEMES, PENSION INVESTMENT OPPORTUNITIES; PENSION MANAGE-

**CLASS 36—(Continued).**

MENT, NAMELY, INVESTING PENSION FUND MONEY IN STOCKS, BONDS, INVESTMENT FUNDS; BANKING; CAPITAL INVESTMENT CONSULTATION; MUTUAL FUND INVESTMENT; PROVIDING DERIVATIVE FUNDS FOR OTHERS, NAMELY, ALLOCATING ASSETS TO DERIVATIVE FUNDS; PROVIDING AND MANAGING INDIVIDUAL SAVINGS ACCOUNTS (ISAS), PERSONAL EQUITY PLANS (PEPS), NAMELY, INVESTING IN SHARES, BONDS AND INVESTMENT FUNDS; VENTURE CAPITAL INVESTMENT; PROVIDING EMERGING MARKETS EQUITY PORTFOLIOS, NAMELY, ASSISTING OTHERS WITH THE COMPLETION OF FINANCIAL TRANSACTIONS FOR STOCKS, BONDS, SECURITIES AND EQUITIES; EMERGING MARKETS FINANCIAL INVESTMENTS, NAMELY, PRIVATE EQUITY FUND INVESTMENTS SERVICES, MANAGEMENT OF STOCKS AND BONDS IN EMERGING MARKET REGIONS; FINANCIAL SERVICES, NAMELY, ASSISTING OTHERS WITH THE COMPLETION OF FINANCIAL TRANSACTIONS FOR EQUITY INVESTMENTS, FIXED INCOME INVESTMENTS, COMPOSITE BONDS, OVERSEAS EQUITY INVESTMENTS, BOND INVESTMENTS, CASH FUNDS, UNIT TRUSTS, MUTUAL TRUSTS, PENSION SCHEMES, INSTITUTIONAL INVESTMENT PORTFOLIOS, PRIVATE SECTOR INVESTMENT PORTFOLIOS, PROVIDING PRIVATE INVESTOR PLANS, PEP TRANSFER PLANS; FINANCIAL MANAGEMENT OF PRIVATE EQUITY FUNDS, HEDGE FUNDS, OFF-SHORE FUNDS, EMERGING DEBT INVESTMENTS, GOVERNMENT BONDS INVESTMENTS, CORPORATE BONDS INVESTMENTS, HIGH YIELD BOND INVESTMENTS, RISK ALTERED FUND PRODUCTS AND INSTITUTIONAL PENSION SCHEMES; PROVIDING INVESTMENT ADVICE; INVESTMENT FUNDS FOR CHARITIES, NAMELY, FUNDS INVESTMENT AND PROVIDING INVESTMENT ADVICE; PROVIDING FINANCIAL INFORMATION, OPINIONS, ESTIMATES, AND FORECASTS ALL RELATING TO INVESTMENTS, INVESTMENT VEHICLES, EQUITIES, WORLD MARKETS, CURRENCIES, COMPANY PERFORMANCES; PROVIDING FINANCIAL REPORTS AND UPDATING REPORTS IN THE FIELD OF PORTFOLIO PERFORMANCES; PROVIDING FINANCIAL FORECASTS RELATING TO CORPORATE PROFITS AND PRICE/EARNINGS RATIO; PROVIDING INVESTMENT STRATEGIES; PROVIDING FINANCIAL MARKET DATA; INVESTMENT ADVISORY AS TO ASSET ALLOCATION AND STOCK SELECTION; ASSET MANAGEMENT, NAMELY, ASSET MANAGEMENT RELATING TO PROPERTY, EQUITIES, BONDS, AND STRUCTURED PRODUCTS IN THE NATURE OF FINANCIAL MANAGEMENT OF THESE PRODUCTS DESIGNED TO GIVE INCREASED INCOME AND PROTECTION, PROVIDING MONEY MANAGEMENT, TAILORING OF FUNDS FOR INVESTORS; CLOSED-END FUND INVESTMENT SERVICES, FINANCIAL MARKET ANALYSIS SERVICES; PROPERTY PROJECT MANAGEMENT AND FINANCING OF REDEVELOPMENT, CASH MANAGEMENT SERVICES, ADMINISTRATION OF INVESTMENTS, NAMELY, STOCKS, SECURITIES, MUTUAL FUNDS AND BONDS, SAVINGS PLANS AND CLOSED-END FUND VEHICLES IN THE NATURE OF INVESTMENT TRUSTS; ADVISORY SERVICES FOR INDEPENDENT FINANCIAL ADVISORS; PROVIDING FINANCIAL DATA RELATING TO INVESTMENT FUND PERFORMANCES; PROVIDING FINANCIAL RESEARCH VIA THE INTERNET AND OTHER INTERACTIVE ELECTRONIC PLATFORMS RELATING TO MONEY MARKETS, WORLD CURRENCIES, CORPORATE PROFITS, PRICE/EARNINGS RATIO, COMPANY INFORMATION, AND PERFORMANCES AND MARKET SECTORS; STOCK EXCHANGE QUOTATION SERVICES; FINANCIAL INFORMATION PROVIDED ON-LINE VIA THE INTERNET AND OTHER INTERACTIVE ELECTRONIC MEDIA IN THE FIELDS OF FINANCE AND INVESTMENTS FEATURING FUND CHARTING, PROVISION OF FUND PRICES, AND STOCK EXCHANGE QUOTATION SERVICES; INVESTMENT ADVISORY AND FINANCIAL MANAGEMENT RELATING TO RETIREMENT, RETIREMENT FUNDS, 401K AND 403(B) FUNDS, PENSIONS, FOUNDATIONS, ANNUITY AND VARIABLE LIFE FUNDS (U.S. CLS. 100, 101 AND 102).

MARIA-VICTORIA SUAREZ, EXAMINING ATTORNEY

**CLASS 36—(Continued).**

SN 85-135,736. MKP CAPITAL MANAGEMENT, L.L.C., NEW YORK, NY. FILED 9-22-2010.

## RCPM RISK CONTROLLED PROFIT MAXIMIZATION

THE MARK CONSISTS OF STANDARD CHARACTERS WITHOUT CLAIM TO ANY PARTICULAR FONT, STYLE, SIZE, OR COLOR.

NO CLAIM IS MADE TO THE EXCLUSIVE RIGHT TO USE "RISK CONTROLLED PROFIT MAXIMIZATION", APART FROM THE MARK AS SHOWN.

FOR FINANCIAL RISK MANAGEMENT SERVICES (U.S. CLS. 100, 101 AND 102).

FIRST USE 5-0-2009; IN COMMERCE 5-0-2009.

EDWARD FENNESSY, EXAMINING ATTORNEY

SN 85-137,281. ALTEGRIS SERVICES, L.L.C., LAJOLLA, CA. FILED 9-24-2010.

## ALTEGRIS 40 INDEX

THE MARK CONSISTS OF STANDARD CHARACTERS WITHOUT CLAIM TO ANY PARTICULAR FONT, STYLE, SIZE, OR COLOR.

OWNER OF U.S. REG. NOS. 2,655,064, 2,670,353 AND OTHERS.

NO CLAIM IS MADE TO THE EXCLUSIVE RIGHT TO USE "40 INDEX", APART FROM THE MARK AS SHOWN.

FOR FINANCIAL AND INVESTMENT ADVISORY SERVICES; FINANCIAL AND INVESTMENT INFORMATION SERVICES; FINANCIAL CONSULTATION AND RESEARCH; RATING SERVICES, NAMELY, REGARDING PERFORMANCE OF COMMODITIES AND INVESTMENTS; PROVIDING AND UPDATING INDEXES OF COMMODITIES VALUES; FINANCIAL DATA AND COMMODITY RESEARCH (U.S. CLS. 100, 101 AND 102).

FIRST USE 9-13-2010; IN COMMERCE 9-13-2010.

HEATHER SAPP, EXAMINING ATTORNEY

**CLASS 36—(Continued).**

SN 85-142,563. STANCORP FINANCIAL GROUP, INC., PORTLAND, OR. FILED 9-30-2010.

**COMPASSIONATE CARE**

THE MARK CONSISTS OF STANDARD CHARACTERS WITHOUT CLAIM TO ANY PARTICULAR FONT, STYLE, SIZE, OR COLOR.

NO CLAIM IS MADE TO THE EXCLUSIVE RIGHT TO USE "CARE", APART FROM THE MARK AS SHOWN.

FOR UNDERWRITING OF INSURANCE, NAMELY, DISABILITY AND DISABILITY INCOME INSURANCE BY PROVIDING INSURANCE BENEFITS TO REPLACE LOST INCOME OF INDIVIDUALS CARING FOR FAMILY MEMBERS; ADMINISTRATION OF DISABILITY AND DISABILITY INCOME INSURANCE CLAIMS, NAMELY, PROVIDING INSURANCE BENEFITS TO REPLACE LOST INCOME OF INDIVIDUALS CARING FOR FAMILY MEMBERS (U.S. CLS. 100, 101 AND 102).

KAPIL BHANOT, EXAMINING ATTORNEY

SN 85-142,568. STANCORP FINANCIAL GROUP, INC., PORTLAND, OR. FILED 9-30-2010.

**COMPASSIONATE CARE BENEFIT**

THE MARK CONSISTS OF STANDARD CHARACTERS WITHOUT CLAIM TO ANY PARTICULAR FONT, STYLE, SIZE, OR COLOR.

NO CLAIM IS MADE TO THE EXCLUSIVE RIGHT TO USE "CARE BENEFIT", APART FROM THE MARK AS SHOWN.

FOR UNDERWRITING OF INSURANCE, NAMELY, DISABILITY AND DISABILITY INCOME INSURANCE BY PROVIDING INSURANCE BENEFITS TO REPLACE LOST INCOME OF INDIVIDUALS CARING FOR FAMILY MEMBERS; ADMINISTRATION OF DISABILITY AND DISABILITY INCOME INSURANCE CLAIMS, NAMELY, PROVIDING INSURANCE BENEFITS TO REPLACE LOST INCOME OF INDIVIDUALS CARING FOR FAMILY MEMBERS (U.S. CLS. 100, 101 AND 102).

KAPIL BHANOT, EXAMINING ATTORNEY

SN 85-143,725. CROSS COUNTRY HOME SERVICES, INC., FT. LAUDERDALE, FL. FILED 10-2-2010.

**HOMECENTRIC**

THE MARK CONSISTS OF STANDARD CHARACTERS WITHOUT CLAIM TO ANY PARTICULAR FONT, STYLE, SIZE, OR COLOR.

FOR PROVIDING SERVICE CONTRACTS IN THE FIELD OF HOME HEATING, COOLING, VENTILATION, ELECTRICAL AND PLUMBING SYSTEMS AND HOME APPLIANCES (U.S. CLS. 100, 101 AND 102).

APRIL HESIK, EXAMINING ATTORNEY

**CLASS 36—(Continued).**

SN 85-146,137. SSC DISABILITY, LLC, SHELTON, CT. FILED 10-6-2010.

**MORE THAN YOU EXPECT.  
JUST WHAT YOU NEED.**

THE MARK CONSISTS OF STANDARD CHARACTERS WITHOUT CLAIM TO ANY PARTICULAR FONT, STYLE, SIZE, OR COLOR.

FOR SOCIAL SECURITY AND MEDICARE CLAIMS ADMINISTRATION AND CONSULTING SERVICES RENDERED TO INDIVIDUALS (U.S. CLS. 100, 101 AND 102).

FIRST USE 10-6-2010; IN COMMERCE 10-6-2010.  
JEFFREY LOOK, EXAMINING ATTORNEY

SN 85-147,244. E CAPITAL PARTNERS, LLC, ASHTABULA, OH. FILED 10-7-2010.



NO CLAIM IS MADE TO THE EXCLUSIVE RIGHT TO USE "ENTREPRENEUR CAPITAL PARTNERS", APART FROM THE MARK AS SHOWN.

THE COLOR(S) GREEN, BLACK, BLUE, AND RED IS/ ARE CLAIMED AS A FEATURE OF THE MARK.

THE MARK CONSISTS OF THE LETTER "E", THE PHRASE "ENTREPRENEUR CAPITAL PARTNERS", AND A RECTANGLE. THE LETTER "E" IS STYLIZED AND LOCATED OVER TOP OF AND ABOVE THE LEFT SIDE OF THE RECTANGLE. THE FIRST PRONG OF THE LETTER "E" IS GREEN, THE SECOND PRONG IS BLUE, AND THE THIRD PRONG IS RED. THE PORTIONS OF THE LETTER "E" CONNECTING THE FIRST AND SECOND PRONGS AND THE SECOND AND THIRD PRONGS ARE BLACK. THE PHRASE "ENTREPRENEUR CAPITAL PARTNERS" IS LOCATED TO THE RIGHT OF THE LETTER "E". THE WORD "ENTREPRENEUR" IS IN BLACK STYLIZED LETTERS AND IS LOCATED TO THE RIGHT OF THE THIRD PRONG OF THE LETTER E AND ABOVE THE RECTANGLE. THE WORD "CAPITAL" IS IN COLORLESS STYLIZED LETTERS AND IS LOCATED BELOW THE WORD "ENTREPRENEUR" AND OVER TOP OF THE RECTANGLE. THE WORD "PARTNERS" IS IN BLACK STYLIZED LETTERS AND IS LOCATED BELOW THE WORD "CAPITAL" AND BELOW THE RECTANGLE. THE RECTANGLE IS BLACK AND IS LOCATED UNDERNEATH THE LETTER "E" AND UNDERNEATH THE WORD "CAPITAL". THE RECTANGLE AND THE LETTER "E" ARE SEPARATED BY A COLORLESS BARRIER.

FOR COMMERCIAL LENDING SERVICES; FINANCIAL SERVICES, NAMELY, MONEY LENDING (U.S. CLS. 100, 101 AND 102).

VIVIAN MICZNIK FIRST, EXAMINING ATTORNEY



**CLASS 36—(Continued).**

SN 85-147,595. ZIONS BANCORPORATION, SALT LAKE CITY, UT. FILED 10-7-2010.

**ZIONS ENERGY LINK**

THE MARK CONSISTS OF STANDARD CHARACTERS WITHOUT CLAIM TO ANY PARTICULAR FONT, STYLE, SIZE, OR COLOR.

OWNER OF U.S. REG. NOS. 2,380,325, 2,381,006 AND 2,531,436.

NO CLAIM IS MADE TO THE EXCLUSIVE RIGHT TO USE "ENERGY", APART FROM THE MARK AS SHOWN.

FOR FINANCIAL SERVICES, NAMELY, MONEY LENDING AND FINANCIAL CONSULTING SERVICES (U.S. CLS. 100, 101 AND 102).

MATTHEW KLINE, EXAMINING ATTORNEY

SN 85-147,778. BURBANK COMMUNITY FEDERAL CREDIT UNION, BURBANK, CA. FILED 10-7-2010.

**UME**

THE MARK CONSISTS OF STANDARD CHARACTERS WITHOUT CLAIM TO ANY PARTICULAR FONT, STYLE, SIZE, OR COLOR.

FOR FINANCIAL SERVICES, NAMELY, CREDIT UNION SERVICES, SAVINGS AND YOUTH SAVINGS ACCOUNTS, CHECKING ACCOUNTS, MONEY MARKET ACCOUNTS, CERTIFICATES OF DEPOSIT, IRAS, DEFERRED COMPENSATION ACCOUNTS, LOAN PROGRAMS, NAMELY, VEHICLE, CREDIT CARDS, LINES OF CREDIT, COMPUTER LOANS, REAL ESTATE LOANS, MORTGAGES, HOME EQUITY LOANS, ONLINE BANKING SERVICES, AUTOMATED TELLER MACHINE SERVICES, HOME BANKING, BILL PAY, ELECTRONIC DEPOSITS, ATM ACCESS SERVICES; INVESTMENT SERVICES, NAMELY, INVESTMENT ADVICE SERVICES, FUND TRANSFER AND TRANSACTION SERVICES; AND BANKING SERVICES PROVIDED BY TELEPHONE CONNECTIONS (U.S. CLS. 100, 101 AND 102).

INGRID C. EULIN, EXAMINING ATTORNEY

SN 85-148,980. CLARK-THEEDERS INSURANCE AGENCY, INC., WEST CHESTER, OH. FILED 10-9-2010.

**RISKSOURCE**

THE MARK CONSISTS OF STANDARD CHARACTERS WITHOUT CLAIM TO ANY PARTICULAR FONT, STYLE, SIZE, OR COLOR.

FOR INSURANCE AGENCY AND BROKERAGE SERVICES IN THE FIELD OF PROPERTY, CASUALTY AND LIFE INSURANCE; INSURANCE RISK MANAGEMENT CONSULTING (U.S. CLS. 100, 101 AND 102).

BENJAMIN OKEKE, EXAMINING ATTORNEY

**CLASS 36—(Continued).**

SN 85-149,670. PRIORITY ONE CREDIT UNION, SOUTH PASADENA, CA. FILED 10-11-2010.

**YOUR FINANCIAL FITNESS CENTER**

THE MARK CONSISTS OF STANDARD CHARACTERS WITHOUT CLAIM TO ANY PARTICULAR FONT, STYLE, SIZE, OR COLOR.

NO CLAIM IS MADE TO THE EXCLUSIVE RIGHT TO USE "FINANCIAL" AND "CENTER", APART FROM THE MARK AS SHOWN.

FOR CREDIT UNION SERVICES (U.S. CLS. 100, 101 AND 102).

FIRST USE 10-11-2010; IN COMMERCE 10-11-2010.

NAAKWAMA ANKRAH, EXAMINING ATTORNEY

SN 85-149,944. VOI INSURANCE SOLUTIONS, LLC, CALABASAS, CA. FILED 10-11-2010.



OWNER OF U.S. REG. NO. 3,871,527. NO CLAIM IS MADE TO THE EXCLUSIVE RIGHT TO USE "INSURANCE SOLUTIONS", APART FROM THE MARK AS SHOWN.

THE COLOR(S) GREY, WHITE, BLUE AND BLACK IS/ARE CLAIMED AS A FEATURE OF THE MARK.

THE MARK CONSISTS OF A CIRCULAR GLOBE WITH A WHITE BACKGROUND AND OUTLINED IN GREY WITH THREE HORIZONTAL AND TWO VERTICAL GREY LINES CROSSING THE GLOBE WITH AN ELIPSE APPEARING IN BLUE DISSECTED FROM THE GLOBE AND ALL APPEARING BEFORE THE WORDS, "VOI", APPEARING IN BLUE, WHICH APPEARS ABOVE THE WORDS, INSURANCE SOLUTIONS, APPEARING IN GREY WITH THE WORDS, RIGHT PRICE RIGHT COVERAGE AND RIGHT NOW APPEARING IN BLACK DIRECTLY BELOW.

THE ENGLISH TRANSLATION OF VOI IN THE MARK IS YOU.

FOR INSURANCE BROKERAGE SERVICES (U.S. CLS. 100, 101 AND 102).

FIRST USE 1-1-2010; IN COMMERCE 1-1-2010.

ANDREA BUTLER, EXAMINING ATTORNEY

**CLASS 36—(Continued).**

SN 85-150,247. DIXON HUGHES WEALTH ADVISORS LLC, ASHEVILLE, NC. FILED 10-12-2010.

**A More Principled 401(k)**

THE MARK CONSISTS OF STANDARD CHARACTERS WITHOUT CLAIM TO ANY PARTICULAR FONT, STYLE, SIZE, OR COLOR.

NO CLAIM IS MADE TO THE EXCLUSIVE RIGHT TO USE "401(K)", APART FROM THE MARK AS SHOWN.

FOR FINANCIAL PLANNING; FINANCIAL PLANNING CONSULTATION; INVESTMENT ADVICE; INVESTMENT ADVISORY SERVICES (U.S. CLS. 100, 101 AND 102).

FIRST USE 10-8-2010; IN COMMERCE 10-8-2010.  
KELLY TRUSILO, EXAMINING ATTORNEY

SN 85-150,265. AVITAS, INC., DBA AVITAS, CHANTILLY, VA. FILED 10-12-2010.

**AVITAS**

THE MARK CONSISTS OF STANDARD CHARACTERS WITHOUT CLAIM TO ANY PARTICULAR FONT, STYLE, SIZE, OR COLOR.

OWNER OF U.S. REG. NOS. 1,388,642 AND 1,406,106.

FOR FINANCIAL ADVISORY AND CONSULTANCY SERVICES RELATED TO VALUATION, PURCHASE, SALE AND LEASING OF COMMERCIAL AIRCRAFT (U.S. CLS. 100, 101 AND 102).

FIRST USE 1-1-1990; IN COMMERCE 1-1-1990.  
KRISTINA MORRIS, EXAMINING ATTORNEY

SN 85-150,912. JANUS INTERNATIONAL HOLDING LLC, DENVER, CO. FILED 10-12-2010.



THE COLOR(S) RED AND BLACK IS/ARE CLAIMED AS A FEATURE OF THE MARK.

THE MARK CONSISTS OF A TRIANGLE SHADED COMPLETELY IN RED COLOR WITH THE TOP OF THE TRIANGLE FACING THE EAST DIRECTION. ON THE RIGHT SIDE OF THE TRIANGLE ARE THE LETTERS AND PUNCTUATION IN BLACK COLOR "ADVISORDRIVEN." UNDERNEATH THOSE LETTERS AND PUNCTUATION, ON THE RIGHT SIDE OF THE BOTTOM OF THE TRIANGLE, ARE THE LETTERS AND PUNCTUATION IN BLACK COLOR "ADVISORSOLD." "ADVISOR" IS IN BOLD PRINT.

FOR INVESTMENT ADVISORY SERVICES; INVESTMENT OF FUNDS FOR OTHERS; MUTUAL FUND INVESTMENT (U.S. CLS. 100, 101 AND 102).

FIRST USE 10-4-2010; IN COMMERCE 10-4-2010.  
CHRISTINA SOBRAL, EXAMINING ATTORNEY

**CLASS 36—(Continued).**

SN 85-151,242. MINY DEVELOPMENT, LLC, FARMINGTON, MI. FILED 10-13-2010.



NO CLAIM IS MADE TO THE EXCLUSIVE RIGHT TO USE "HOME" AND "PROGRAM", APART FROM THE MARK AS SHOWN.

THE MARK CONSISTS OF THE WORDS "HOME SPONSORSHIP PROGRAM" WITH THE WORDS "IT STARTS WITH YOU" BELOW AND A LINE CONNECTING THE "H" FROM "HOME" LEADING TO A HOUSE DESIGN ON THE RIGHT.

FOR REAL ESTATE BROKERAGE (U.S. CLS. 100, 101 AND 102).

FIRST USE 6-16-2010; IN COMMERCE 6-16-2010.  
KAREN K. BUSH, EXAMINING ATTORNEY

SN 85-151,558. CLW REALTY GROUP, INC., TAMPA, FL. FILED 10-13-2010.

**CLW REAL ESTATE SERVICES GROUP**

THE MARK CONSISTS OF STANDARD CHARACTERS WITHOUT CLAIM TO ANY PARTICULAR FONT, STYLE, SIZE, OR COLOR.

NO CLAIM IS MADE TO THE EXCLUSIVE RIGHT TO USE "REAL ESTATE SERVICES GROUP", APART FROM THE MARK AS SHOWN.

FOR REAL ESTATE SERVICES, NAMELY, RENTAL, BROKERAGE, LEASING AND MANAGEMENT OF COMMERCIAL PROPERTY, OFFICES AND OFFICE SPACE (U.S. CLS. 100, 101 AND 102).

FIRST USE 6-17-1999; IN COMMERCE 6-17-1999.  
SUSAN LESLIE DUBOIS, EXAMINING ATTORNEY

SN 85-151,752. INTERCONTINENTALEXCHANGE, INC., ATLANTA, GA. FILED 10-13-2010.

**MARKETS ARE MOVING**

THE MARK CONSISTS OF STANDARD CHARACTERS WITHOUT CLAIM TO ANY PARTICULAR FONT, STYLE, SIZE, OR COLOR.

FOR PROVIDING FINANCIAL SERVICES IN THE NATURE OF PROVIDING REAL-TIME AND/OR HISTORIC FINANCIAL INFORMATION RELATING TO THE PURCHASING, SELLING, FINANCIAL MANAGEMENT, MONITORING, AND/OR TRACKING OF GLOBAL MARKETS, CURRENCIES, COMMODITIES, FUTURES, DERIVATIVES, SECURITIES, SHARES, STOCKS, OPTIONS, AND OTHER RELATED FINANCIAL INSTRUMENTS; PROVIDING FINANCIAL INFORMATION IN THE NATURE OF LIVE PRICES, LIVE CHARTS, LIVE NEWS, TECHNICAL STUDIES, AND FINANCIAL WEATHER MAPS, ALL RELATING TO CURRENCIES, COMMODITIES, FUTURES, DERIVA-

**CLASS 36—(Continued).**

TIVES, SECURITIES, SHARES, STOCKS, OPTIONS, AND OTHER RELATED FINANCIAL INSTRUMENTS; PROVIDING FINANCIAL INFORMATION AND ANALYSIS RELATING TO FINANCIAL PRODUCTS, FINANCIAL MARKETS, FINANCIAL INVESTMENTS, AND FINANCIAL TRANSACTIONS IN THE NATURE OF MARKET DATA, MARKET VIEWS, FINANCING DATA, PRODUCT VOLUME, WEIGHT, AND PRICING, SETTLEMENT DATA, ORDER DATA, QUANTITY DATA, DELIVERY DATA, DATE AND TIME DATA, TRADE-TYPE, TRANSACTION STATUS, PRICE INDICES, RATE QUOTES, HISTORICAL FINANCIAL DATA, MARKET DEPTH DATA, CONTRACT SYMBOLS, AND/OR TRANSACTION SUMMARY DATA ASSOCIATED WITH COMMODITIES, FUTURES, DERIVATIVES, SECURITIES, SHARES, STOCKS, OPTIONS, AND OTHER RELATED FINANCIAL INSTRUMENTS; DETERMINING AND COMPILING REAL TIME AND/OR HISTORIC PRICE INDICES AND RELATED FINANCIAL INFORMATION RELATING TO CURRENCIES, COMMODITIES, FUTURES, DERIVATIVES, SECURITIES, SHARES, STOCKS, OPTIONS, AND OTHER RELATED FINANCIAL INSTRUMENTS; PROVIDING FINANCIAL RATE QUOTES IN THE NATURE OF TRANSACTION SETTLEMENT RATES, FINANCIAL MARGIN RATES, AND/OR CURRENCY EXCHANGE RATES; PROVIDING FINANCIAL INFORMATION IN THE NATURE OF REAL-TIME AND HISTORIC BIDS AND OFFERS FOR COMMODITIES, FUTURES, DERIVATIVES, SECURITIES, SHARES, STOCKS, OPTIONS, AND RELATED FINANCIAL INSTRUMENTS EITHER INDIVIDUALLY OR AS PART OF A MARKET DEPTH DISPLAY; PROVIDING REAL-TIME AND HISTORIC PROFIT AND LOSS REPORTING FOR FINANCIAL TRANSACTIONS INVOLVING COMMODITIES, FUTURES, DERIVATIVES, SECURITIES, SHARES, STOCKS, OPTIONS, AND RELATED FINANCIAL INSTRUMENTS TRANSACTIONS; PROVIDING FINANCIAL INFORMATION IN THE NATURE OF REAL-TIME AND HISTORIC REPORTING OF ORDERS FOR COMMODITIES, FUTURES, DERIVATIVES, SECURITIES, SHARES, STOCKS, OPTIONS, AND RELATED FINANCIAL INSTRUMENTS; FINANCIAL MARKET TRACKING AND MONITORING SERVICES; TRACKING AND MONITORING OF DAILY LONG AND SHORT FINANCIAL POSITIONS; PROVIDING FINANCIAL INFORMATION ABOUT VARIOUS TOPICS AND INDUSTRIES THAT WOULD AFFECT PRICING OF COMMODITIES, FUTURES, DERIVATIVES, SECURITIES, SHARES, STOCKS, OPTIONS, AND/OR OTHER RELATED FINANCIAL INSTRUMENTS; PROVIDING FINANCIAL EXCHANGE AND CLEARING SERVICES FOR TRANSACTIONS INVOLVING CURRENCIES, COMMODITIES, FUTURES, DERIVATIVES, SECURITIES, SHARES, STOCKS, OPTIONS, AND/OR OTHER RELATED FINANCIAL INSTRUMENTS; FINANCIAL TRANSACTION EXECUTION SERVICES IN THE NATURE OF PLACING, VIEWING, EDITING, AND CANCELING BUY AND SELL ORDERS; FINANCIAL RISK AND CREDIT MANAGEMENT SERVICES; PROVIDING FINANCIAL SERVICES IN THE NATURE OF STRAIGHT THROUGH PROCESSING AND AUTOMATION OF FINANCIAL TRANSACTIONS BETWEEN DEALERS, PRIME BROKERS, BUY-SIDE PARTICIPANTS AND/OR FINANCIAL SERVICE PROVIDERS; PROVIDING ANY OR ALL OF THE AFORESAID SERVICES ON-LINE FROM A GLOBAL COMPUTER NETWORK, THE INTERNET, AND/OR VIA INTERACTIVE ELECTRONIC MEDIA; AND PROVIDING ANY OR ALL OF THE AFORESAID SERVICES ONLINE VIA A WEBSITE THAT IS ASSESSABLE BY SUBSCRIBERS VIA A COMPUTER TERMINAL AND/OR A MOBILE COMMUNICATION DEVICE (U.S. CLS. 100, 101 AND 102).  
MELISSA VALLILLO, EXAMINING ATTORNEY

**CLASS 36—(Continued).**

SN 85-151,761. LYNDON PROPERTY INSURANCE COMPANY, CHESTERFIELD, MO. FILED 10-13-2010.



NO CLAIM IS MADE TO THE EXCLUSIVE RIGHT TO USE "MEMBER'S" AND "VEHICLE PROTECTION PLAN", APART FROM THE MARK AS SHOWN.

THE MARK CONSISTS OF A CIRCLE DESIGN WHERE A ROAD DESIGN WITH A DOTTED LINE DOWN THE MIDDLE EXTENDS FROM THE SIDE OF THE CIRCLE. THERE IS A GLOBE DESIGN IN THE MIDDLE OF THE CIRCLE WITH A RECTANGLE OVER THE TOP OF THE GLOBE WITH THE WORD "ADVANTAGE" IN THE RECTANGLE. THE WORD "MEMBER'S" IS WRITTEN ABOVE THE GLOBE AND THE WORDS "VEHICLE PROTECTION PLAN" ARE WRITTEN BELOW THE GLOBE DESIGN.

FOR EXTENDED WARRANTY SERVICES, NAMELY, SERVICE CONTRACTS; INSURANCE SERVICES, NAMELY, UNDERWRITING EXTENDED WARRANTY CONTRACTS IN THE FIELD OF AUTOMOBILES; PROVIDING VEHICLE SERVICE AGREEMENTS ON VEHICLES MANUFACTURED BY OTHERS FOR MECHANICAL BREAKDOWN AND SERVICING; UNDERWRITING WARRANTY PROGRAMS IN THE FIELD OF AUTOMOBILES (U.S. CLS. 100, 101 AND 102).  
LINDA ORNDORFF, EXAMINING ATTORNEY

SN 85-151,790. GOLDEN VALLEY INSURANCE, NORTH HOLLYWOOD, CA. FILED 10-13-2010.



NO CLAIM IS MADE TO THE EXCLUSIVE RIGHT TO USE "INSURANCE", APART FROM THE MARK AS SHOWN.

THE MARK CONSISTS OF A CURVED, ABSTRACT IMAGE ON THE LEFT. TO THE RIGHT THERE IS THE STYLIZED TEXT "GOLDEN VALLEY INSURANCE".

FOR INSURANCE AGENCY AND BROKERAGE (U.S. CLS. 100, 101 AND 102).  
FIRST USE 6-1-2007; IN COMMERCE 6-1-2007.  
REBECCA SMITH, EXAMINING ATTORNEY

**CLASS 36—(Continued).**

SN 85-152,423. MID-ATLANTIC VENTURE INVESTMENT COMPANY, LLC, WASHINGTON, DC. FILED 10-14-2010.

REINVENTING VENTURE CAPITAL

THE MARK CONSISTS OF STANDARD CHARACTERS WITHOUT CLAIM TO ANY PARTICULAR FONT, STYLE, SIZE, OR COLOR.

NO CLAIM IS MADE TO THE EXCLUSIVE RIGHT TO USE "VENTURE CAPITAL", APART FROM THE MARK AS SHOWN.

FOR FINANCIAL SERVICES IN THE NATURE OF VENTURE CAPITAL INVESTMENT SERVICES; VENTURE CAPITAL SERVICES, NAMELY, PROVIDING FINANCING TO EMERGING AND START-UP COMPANIES IN HIGH TECHNOLOGY, BIOTECHNOLOGY AND LIFE SCIENCES (U.S. CLS. 100, 101 AND 102).  
APRIL ROACH, EXAMINING ATTORNEY

SN 85-152,527. SAFE CREDIT UNION, NORTH HIGHLANDS, CA. FILED 10-14-2010.

CASHTASTIC REWARDS

THE MARK CONSISTS OF STANDARD CHARACTERS WITHOUT CLAIM TO ANY PARTICULAR FONT, STYLE, SIZE, OR COLOR.

NO CLAIM IS MADE TO THE EXCLUSIVE RIGHT TO USE "REWARDS", APART FROM THE MARK AS SHOWN.

FOR FINANCIAL SERVICES, NAMELY, DEBIT CARD SERVICES, DEBIT CARD LOYALTY PROGRAM PROVIDING CASH REBATES FOR PURCHASES WITH USE OF THE DEBIT CARD AT PARTICIPATING MERCHANTS (U.S. CLS. 100, 101 AND 102).  
JAMES A. RAUEN, EXAMINING ATTORNEY

**CLASS 36—(Continued).**

SN 85-152,809. ASSOCIATION INSURANCE SERVICES, INC., CRYSTAL LAKE, IL. FILED 10-14-2010.



NO CLAIM IS MADE TO THE EXCLUSIVE RIGHT TO USE "ASSOCIATION INSURANCE" AND "HOME FURNISHINGS PROGRAM", APART FROM THE MARK AS SHOWN.

THE COLOR(S) RED, BLUE, YELLOW, AND GREEN IS/ARE CLAIMED AS A FEATURE OF THE MARK.

THE MARK CONSISTS OF THE WORDING "ASSOCIATION INSURANCE HOME FURNISHINGS PROGRAM" IN BLUE AND A LINE WITH SMALL COLORED SQUARES IN THE COLORS RED, BLUE, YELLOW, AND GREEN SEPARATES "ASSOCIATION INSURANCE" AND "HOME FURNISHINGS PROGRAM".

FOR INSURANCE SERVICES, NAMELY, UNDERWRITING COMMERCIAL INSURANCE, PROPERTY AND CASUALTY, WORKER'S COMPENSATION, AUTO AND HEALTH INSURANCE; INSURANCE SERVICES, NAMELY, VIATICAL SETTLEMENT SERVICES, LIFE SETTLEMENT SERVICES FOR INSURANCE POLICYHOLDERS, AND SENIOR SETTLEMENT SERVICES FOR INSURANCE POLICYHOLDERS (U.S. CLS. 100, 101 AND 102).

FIRST USE 3-23-2010; IN COMMERCE 6-30-2010.  
PAUL F. GAST, EXAMINING ATTORNEY

SN 85-153,248. MARTIROS HOLDINGS, LLC, SHERBORN, MA. FILED 10-14-2010.



NO CLAIM IS MADE TO THE EXCLUSIVE RIGHT TO USE "PLANNING" AND "INVESTING", APART FROM THE MARK AS SHOWN.

THE MARK CONSISTS OF A SET OF THREE CIRCLES ARRANGED HORIZONTALLY, THE FIRST OF WHICH CONTAINS A HAND PLANTING A SEED, THE SECOND OF WHICH CONTAINS A PLANT IN THE GROUND, THE THIRD OF WHICH CONTAINS A HAND PICKING FRUIT FROM A TREE, WITH THE WORD "PLANNING" BELOW THE FIRST CIRCLE, THE WORD "INVESTING" BELOW THE SECOND CIRCLE, AND THE WORD "ENJOYING" BELOW THE THIRD CIRCLE.

FOR PROVIDING A WEB SITE FEATURING INFORMATION ABOUT INVESTING (U.S. CLS. 100, 101 AND 102).  
EDWARD FENNESSY, EXAMINING ATTORNEY

**CLASS 36—(Continued).**

SN 85-153,406. UNIRUSH, LLC, CINCINNATI, OH. FILED 10-15-2010.

**RUSHCARD** 

OWNER OF U.S. REG. NO. 2,826,230.  
THE MARK CONSISTS OF THE WORD "RUSHCARD"  
WITH A STYLIZED "PLUS" SIGN.

FOR FINANCIAL SERVICES IN THE NATURE OF  
DEBIT CARD SERVICES (U.S. CLS. 100, 101 AND 102).

FIRST USE 11-23-2009; IN COMMERCE 11-23-2009.  
JOHN E. MICHOS, EXAMINING ATTORNEY

---

SN 85-154,436. SOCIAL SERVICE COORDINATORS, INC.,  
MIAMI LAKES, FL. FILED 10-17-2010.

**MEDICARE SAVINGS ADVANTAGE**

THE MARK CONSISTS OF STANDARD CHARACTERS  
WITHOUT CLAIM TO ANY PARTICULAR FONT, STYLE,  
SIZE, OR COLOR.

OWNER OF U.S. REG. NO. 3,805,452.

NO CLAIM IS MADE TO THE EXCLUSIVE RIGHT TO  
USE "MEDICARE SAVINGS", APART FROM THE MARK  
AS SHOWN.

FOR SOCIAL SECURITY AND MEDICARE CLAIMS  
ADMINISTRATION AND CONSULTING SERVICES  
RENDERED TO INDIVIDUALS (U.S. CLS. 100, 101  
AND 102).

FIRST USE 1-1-2006; IN COMMERCE 10-6-2010.  
AISHA SALEM, EXAMINING ATTORNEY

---

SN 85-155,164. MENZIES, LAURIE L., BUFFALO, NY. AND  
BEINHÄUER, CHARLES W., BUFFALO, NY. FILED 10-18-  
2010.

**COUNSEL FOR GENERATIONS**

THE MARK CONSISTS OF STANDARD CHARACTERS  
WITHOUT CLAIM TO ANY PARTICULAR FONT, STYLE,  
SIZE, OR COLOR.

NO CLAIM IS MADE TO THE EXCLUSIVE RIGHT TO  
USE "COUNSEL", APART FROM THE MARK AS SHOWN.

FOR ESTATE PLANNING; ESTATE TRUST MANAGE-  
MENT; FINANCIAL SERVICES, NAMELY, ESTATE  
SETTLEMENT SERVICES (U.S. CLS. 100, 101 AND 102).

FIRST USE 10-1-2004; IN COMMERCE 11-1-2004.  
MATTHEW KLINE, EXAMINING ATTORNEY

**CLASS 36—(Continued).**

SN 85-155,619. BENCHMARK BOND RATINGS, INC., GAR-  
DEN CITY, NY. FILED 10-19-2010.

**BENCHMARK BOND RATINGS**

THE MARK CONSISTS OF STANDARD CHARACTERS  
WITHOUT CLAIM TO ANY PARTICULAR FONT, STYLE,  
SIZE, OR COLOR.

NO CLAIM IS MADE TO THE EXCLUSIVE RIGHT TO  
USE "BOND RATINGS", APART FROM THE MARK AS  
SHOWN.

FOR RATINGS SERVICES REGARDING BONDS, AS  
WELL AS LONG AND SHORT TERM DEBT OBLIGA-  
TIONS (U.S. CLS. 100, 101 AND 102).

RONALD MCMORROW, EXAMINING ATTORNEY

---

SN 85-155,673. COASTLINE FEDERAL CREDIT UNION,  
JACKSONVILLE, FL. FILED 10-19-2010.

**FIVE STAR REWARDS**

THE MARK CONSISTS OF STANDARD CHARACTERS  
WITHOUT CLAIM TO ANY PARTICULAR FONT, STYLE,  
SIZE, OR COLOR.

NO CLAIM IS MADE TO THE EXCLUSIVE RIGHT TO  
USE "REWARDS", APART FROM THE MARK AS SHOWN.

FOR CREDIT AND LOAN SERVICES; FINANCING  
AND LOAN SERVICES (U.S. CLS. 100, 101 AND 102).

FIRST USE 8-25-2010; IN COMMERCE 8-25-2010.

RONALD MCMORROW, EXAMINING ATTORNEY

---

SN 85-156,912. FINACCESS MEXICO S.A. DE C.V., SOCIE-  
DAD OPERADORA DE SOCIEDADES DE INVERSION,  
MEXICO D.F., MEXICO, FILED 10-20-2010.

**FINACCESS**

THE MARK CONSISTS OF STANDARD CHARACTERS  
WITHOUT CLAIM TO ANY PARTICULAR FONT, STYLE,  
SIZE, OR COLOR.

FOR FINANCIAL AND INVESTMENT SERVICES,  
NAMELY, FINANCIAL ANALYSIS AND CONSULTING  
SERVICES; FINANCIAL INFORMATION SERVICES VIA  
A GLOBAL COMPUTER NETWORK; INVESTMENT  
CONSULTING SERVICES; FINANCIAL MANAGEMENT  
AND FINANCIAL PORTFOLIO MANAGEMENT SER-  
VICES; SECURITY BROKERAGE SERVICES; INVEST-  
MENT BROKERAGE SERVICES (U.S. CLS. 100, 101 AND  
102).

FIRST USE 3-0-2001; IN COMMERCE 3-0-2001.

MARC LEIPZIG, EXAMINING ATTORNEY

**CLASS 36—(Continued).**

SN 85-157,247. UNITED STATES INFRASTRUCTURE CORPORATION, CARMEL, IN. FILED 10-20-2010.

**RELIABLE CLAIMS RECOVERY**

THE MARK CONSISTS OF STANDARD CHARACTERS WITHOUT CLAIM TO ANY PARTICULAR FONT, STYLE, SIZE, OR COLOR.

NO CLAIM IS MADE TO THE EXCLUSIVE RIGHT TO USE "CLAIMS RECOVERY", APART FROM THE MARK AS SHOWN.

FOR DEBT COLLECTION SERVICES (U.S. CLS. 100, 101 AND 102).

JORDAN BAKER, EXAMINING ATTORNEY

---

SN 85-157,463. ANLIN INDUSTRIES, INC., CLOVIS, CA. FILED 10-20-2010.

**EnergyFit Alliance**

THE MARK CONSISTS OF STANDARD CHARACTERS WITHOUT CLAIM TO ANY PARTICULAR FONT, STYLE, SIZE, OR COLOR.

NO CLAIM IS MADE TO THE EXCLUSIVE RIGHT TO USE "ALLIANCE", APART FROM THE MARK AS SHOWN.

FOR FINANCING AND LOAN SERVICES (U.S. CLS. 100, 101 AND 102).

DOUGLAS LEE, EXAMINING ATTORNEY

---

SN 85-157,723. AVIATOR FUND MANAGEMENT, L.P., STAMFORD, CT. FILED 10-21-2010.

THE MARK CONSISTS OF THE LETTERS "AFM" STYLED. THE "A" AND THE "F" HAVE A DOT IN THE CENTER IN PLACE OF A LINE, FOLLOWED BY A STANDARD "M".

FOR FINANCIAL SERVICES, NAMELY, INVESTMENT MANAGEMENT SERVICES, INVESTMENT ADVISORY SERVICES AND ASSET MANAGEMENT SERVICES (U.S. CLS. 100, 101 AND 102).

FIRST USE 7-1-2003; IN COMMERCE 7-1-2003.  
CURTIS FRENCH, EXAMINING ATTORNEY

**CLASS 36—(Continued).**

SN 85-158,584. GUGGENHEIM CAPITAL, LLC, CHICAGO, IL. FILED 10-21-2010.

**GUGGENHEIM LIFE AND ANNUITY COMPANY**

THE MARK CONSISTS OF STANDARD CHARACTERS WITHOUT CLAIM TO ANY PARTICULAR FONT, STYLE, SIZE, OR COLOR.

OWNER OF U.S. REG. NOS. 3,110,878, 3,712,544 AND OTHERS.

NO CLAIM IS MADE TO THE EXCLUSIVE RIGHT TO USE "LIFE AND ANNUITY COMPANY", APART FROM THE MARK AS SHOWN.

SEC. 2(F) AS TO "GUGGENHEIM".

FOR INFORMATION, ADVISORY, CONSULTANCY AND RESEARCH SERVICES RELATING TO FINANCE AND INVESTMENTS; INSURANCE AND FINANCIAL INFORMATION AND CONSULTANCY SERVICES; FINANCIAL INVESTMENT IN THE FIELDS OF INSURANCE, REINSURANCE AND ANNUITIES; REINSURANCE UNDERWRITING; INSURANCE UNDERWRITING IN THE FIELDS OF LIFE, ACCIDENT AND HEALTH INSURANCE; UNDERWRITING, ISSUANCE AND ADMINISTRATION OF ANNUITIES; AND PROVIDING ONLINE ELECTRONIC DATABASES IN THE FIELDS OF FINANCE, INSURANCE, REINSURANCE, INVESTMENT AND ANNUITIES (U.S. CLS. 100, 101 AND 102).

CHRISTINE MARTIN, EXAMINING ATTORNEY

---

SN 85-158,586. WEST CHESTER OFF CAMPUS HOUSING, LLC, WEST CHESTER, PA. FILED 10-21-2010.

**WEST CHESTER OFF CAMPUS HOUSING**

THE MARK CONSISTS OF STANDARD CHARACTERS WITHOUT CLAIM TO ANY PARTICULAR FONT, STYLE, SIZE, OR COLOR.

NO CLAIM IS MADE TO THE EXCLUSIVE RIGHT TO USE "OFF CAMPUS HOUSING", APART FROM THE MARK AS SHOWN.

SEC. 2(F).

FOR HOUSING AND APARTMENT SERVICES, NAMELY, RENTAL OF STUDENT HOUSING AND APARTMENTS; REAL ESTATE LISTING SERVICES FOR HOUSING RENTALS AND APARTMENT RENTALS; CLASSIFIED REAL ESTATE LISTINGS OF APARTMENT RENTALS AND HOUSING RENTALS; LEASING AND RENTAL OF HOUSES AND APARTMENTS; APARTMENT LOCATING SERVICES FOR OTHERS; MANAGEMENT OF APARTMENTS AND HOUSES; REAL ESTATE SERVICES, NAMELY, PROPERTY MANAGEMENT SERVICES FOR APARTMENT BUILDINGS (U.S. CLS. 100, 101 AND 102).

FIRST USE 1-0-2000; IN COMMERCE 1-0-2000.

WILLIAM VERHOSEK, EXAMINING ATTORNEY

**CLASS 36—(Continued).**

SN 85-158,923. FARM CREDIT SERVICES OF NORTH DAKOTA, MINOT, ND. FILED 10-22-2010.



NO CLAIM IS MADE TO THE EXCLUSIVE RIGHT TO USE "FARM CREDIT SERVICES", APART FROM THE MARK AS SHOWN.

THE COLOR(S) BLUE AND YELLOW IS/ARE CLAIMED AS A FEATURE OF THE MARK.

THE MARK CONSISTS OF THE BLUE STYLIZED WORDS "ONE PASS FARM CREDIT SERVICES" AND AN IMAGE OF A YELLOW ARROW BELOW THE WORD "ONE PASS". THE WORDS "FARM CREDIT SERVICES" ARE WRITTEN ON THE ARROW.

FOR FINANCING AND LOAN SERVICES (U.S. CLS. 100, 101 AND 102).

FIRST USE 9-1-2010; IN COMMERCE 9-1-2010.  
KIM MONINGHOFF, EXAMINING ATTORNEY

SN 85-159,143. IPFS CORPORATION, KANSAS CITY, MO. FILED 10-22-2010.

PARTNERSHIP THAT GOES WAY  
BEYOND THE NUMBERS

THE MARK CONSISTS OF STANDARD CHARACTERS WITHOUT CLAIM TO ANY PARTICULAR FONT, STYLE, SIZE, OR COLOR.

FOR FINANCING OF INSURANCE PREMIUM FOR OTHERS (U.S. CLS. 100, 101 AND 102).

FIRST USE 1-4-2008; IN COMMERCE 1-4-2008.

MARK RADEMACHER, EXAMINING ATTORNEY

SN 85-159,266. MISSOURI DOCTORS MUTUAL INSURANCE COMPANY, ST. JOSEPH, MO. FILED 10-22-2010.

GIVING MISSOURI DOCTORS  
THE PEACE OF MIND TO DO  
WHAT DOCTORS DO BEST

THE MARK CONSISTS OF STANDARD CHARACTERS WITHOUT CLAIM TO ANY PARTICULAR FONT, STYLE, SIZE, OR COLOR.

NO CLAIM IS MADE TO THE EXCLUSIVE RIGHT TO USE "MISSOURI DOCTORS", APART FROM THE MARK AS SHOWN.

FOR INSURANCE UNDERWRITING SERVICES, NAMELY, INSURING HEALTH CARE PROFESSIONALS AGAINST MALPRACTICE CLAIMS (U.S. CLS. 100, 101 AND 102).

FIRST USE 10-15-2010; IN COMMERCE 10-15-2010.  
WILLIAM VERHOSEK, EXAMINING ATTORNEY

**CLASS 36—(Continued).**

SN 85-160,425. LIBERTYNOW, LLC, FRISCO, TX. FILED 10-25-2010.

LIBERTY LIFELINE

THE MARK CONSISTS OF STANDARD CHARACTERS WITHOUT CLAIM TO ANY PARTICULAR FONT, STYLE, SIZE, OR COLOR.

FOR DEBT COUNSELING SERVICES, DEBT MANAGEMENT CONSULTATION SERVICES AND DEBT SETTLEMENT SERVICES (U.S. CLS. 100, 101 AND 102).

TRACY WHITTAKER-BROWN, EXAMINING ATTORNEY

SN 85-160,545. CHARLES SCHWAB & CO., INC., SAN FRANCISCO, CA. FILED 10-25-2010.

WINDHAVEN

THE MARK CONSISTS OF STANDARD CHARACTERS WITHOUT CLAIM TO ANY PARTICULAR FONT, STYLE, SIZE, OR COLOR.

FOR FINANCIAL AND INVESTMENT RESEARCH, STRATEGY, PLANNING, ADVISORY AND BROKERAGE SERVICES (U.S. CLS. 100, 101 AND 102).

KATHERINE STOIDES, EXAMINING ATTORNEY

SN 85-160,614. LIBERTYNOW, LLC, FRISCO, TX. FILED 10-25-2010.

LIBERTY BRIDGE

THE MARK CONSISTS OF STANDARD CHARACTERS WITHOUT CLAIM TO ANY PARTICULAR FONT, STYLE, SIZE, OR COLOR.

FOR DEBT COUNSELING SERVICES, DEBT MANAGEMENT CONSULTATION SERVICES AND DEBT SETTLEMENT SERVICES (U.S. CLS. 100, 101 AND 102).

TRACY WHITTAKER-BROWN, EXAMINING ATTORNEY

**CLASS 36—(Continued).**

SN 85-160,855. MEMBERS COOPERATIVE CREDIT UNION, CLOQUET, MN. FILED 10-25-2010.

# EcoChoice

THE MARK CONSISTS OF STANDARD CHARACTERS WITHOUT CLAIM TO ANY PARTICULAR FONT, STYLE, SIZE, OR COLOR.

FOR ATM BANKING SERVICES; BANKING; BANKING AND FINANCING SERVICES; BANKING SERVICES; BANKING SERVICES PROVIDED BY MOBILE TELEPHONE CONNECTIONS; ELECTRONIC BANKING VIA A GLOBAL COMPUTER NETWORK; HOME BANKING; ISSUANCE OF BANK CHECKS; MERCHANT BANKING SERVICES; MORTGAGE BANKING; MORTGAGE BANKING SERVICES, NAMELY, ORIGATION, ACQUISITION, SERVICING, SECURITIZATION AND BROKERAGE OF MORTGAGE LOANS; ON-LINE BANKING SERVICES; PROVIDING BANK ACCOUNT INFORMATION BY TELEPHONE; TELEPHONE BANKING SERVICES (U.S. CLS. 100, 101 AND 102).

FIRST USE 10-25-2010; IN COMMERCE 10-25-2010.  
BRIDGETT SMITH, EXAMINING ATTORNEY

SN 85-161,617. CHARLES SCHWAB & CO., INC., SAN FRANCISCO, CA. FILED 10-26-2010.

## WINDHAVEN INVESTMENT MANAGEMENT

THE MARK CONSISTS OF STANDARD CHARACTERS WITHOUT CLAIM TO ANY PARTICULAR FONT, STYLE, SIZE, OR COLOR.

NO CLAIM IS MADE TO THE EXCLUSIVE RIGHT TO USE "INVESTMENT MANAGEMENT", APART FROM THE MARK AS SHOWN.

FOR FINANCIAL AND INVESTMENT RESEARCH, STRATEGY, PLANNING, ADVISORY AND BROKERAGE SERVICES (U.S. CLS. 100, 101 AND 102).  
KATHERINE STOIDES, EXAMINING ATTORNEY

SN 85-161,760. CHARLES SCHWAB & CO., INC., SAN FRANCISCO, CA. FILED 10-26-2010.

## WINDHAVEN PORTFOLIOS

THE MARK CONSISTS OF STANDARD CHARACTERS WITHOUT CLAIM TO ANY PARTICULAR FONT, STYLE, SIZE, OR COLOR.

NO CLAIM IS MADE TO THE EXCLUSIVE RIGHT TO USE "PORTFOLIOS", APART FROM THE MARK AS SHOWN.

FOR FINANCIAL AND INVESTMENT RESEARCH, STRATEGY, PLANNING, ADVISORY AND BROKERAGE SERVICES (U.S. CLS. 100, 101 AND 102).  
KATHERINE STOIDES, EXAMINING ATTORNEY

**CLASS 36—(Continued).**

SN 85-170,121. NATIONAL INSURANCE ADVISORS AGENCY, INC., TROY, MI. FILED 11-5-2010.



NO CLAIM IS MADE TO THE EXCLUSIVE RIGHT TO USE "RETIREMENT" "FINANCIAL" "SECURITY" "SAVINGS" "REAL ESTATE" "PERSONAL PROPERTY" "INVESTMENTS" "STOCKS" "BONDS" "OTHER ACCUMULATED ASSETS" "HEALTH INSURANCE" "LIFE INSURANCE" "CRITICAL ILLNESS" "DISABILITY INCOME" "INFORM" "ADVISE" "SERVICE", APART FROM THE MARK AS SHOWN.

THE MARK CONSISTS OF THE WORDING "BUILDING A FOUNDATION" "INFORM" "ADVISE" "SERVICE" SURROUNDING A TRIANGLE DIVIDED INTO SEGMENTS AND CONTAINING THE WORDING "RETIREMENT" "FINANCIAL" "SECURITY" "SAVINGS" "REAL ESTATE" "PERSONAL PROPERTY" "INVESTMENTS" "STOCKS" "BONDS" "OTHER ACCUMULATED ASSETS" "HEALTH INSURANCE" "LIFE INSURANCE" "CRITICAL ILLNESS" "DISABILITY INCOME".

FOR INSURANCE AGENCY SERVICES (U.S. CLS. 100, 101 AND 102).  
CHRISTINE COOPER, EXAMINING ATTORNEY

SN 85-170,641. DAYAN, ELIE, ESCAZU, COSTA RICA, FILED 11-5-2010.



NO CLAIM IS MADE TO THE EXCLUSIVE RIGHT TO USE "VILLAS.COM", APART FROM THE MARK AS SHOWN.

THE COLOR(S) LIGHT GREEN, DARK GREEN, BLACK AND WHITE IS/ARE CLAIMED AS A FEATURE OF THE MARK.

THE MARK CONSISTS OF A FROG WITH LIGHT GREEN COLORING ON THE TOP HALF OF THE BODY AND DARK GREEN COLORING ON THE BOTTOM HALF OF THE BODY. THE FROG HAS TWO (2) ROUND, BLACK EYES WITH WHITE, OVAL CENTERS. THERE IS A WHITE TRIANGULAR SHAPE, SIMILAR TO AN ARROWHEAD, BETWEEN THE EYES OF THE FROG. THERE ARE THREE



**CLASS 36—(Continued).**

(3) DIAMONDS RUNNING DOWN THE CENTER OF THE STOMACH OF THE FROG. EACH DIAMOND HAS A THICK WHITE OUTLINE AND A GREEN CENTER. THE CENTER DIAMOND IS SMALLER THAN THE OTHERS. THERE ARE THREE (3) WHITE SQUARES ON EACH OF THE FROG'S LEGS, STEMMING FROM THE STOMACH AND OUTWARD DOWN THE LEGS, DECREASING IN SIZE. THE ENTIRE FROG IS OUTLINED IN BLACK. IN STYLIZED, BLACK FONT, THE LOGO READS: "ESCAPE-VILLAS.COM".

FOR REAL ESTATE SERVICES, NAMELY, RENTAL OF VACATION HOMES, CONDOMINIUMS, CABINS, AND VILLAS USING PAY PER CLICK ADVERTISING ON A GLOBAL COMPUTER NETWORK (U.S. CLS. 100, 101 AND 102).

FIRST USE 6-7-2003; IN COMMERCE 6-7-2003.  
DANNEAN HETZEL, EXAMINING ATTORNEY



SN 85-171,577. PETHEALTH SERVICES INC., OAKVILLE, ONTARIO, CANADA, FILED 11-8-2010.

# PETANGOCARE

THE MARK CONSISTS OF STANDARD CHARACTERS WITHOUT CLAIM TO ANY PARTICULAR FONT, STYLE, SIZE, OR COLOR.

FOR PET INSURANCE UNDERWRITING SERVICES AND ADMINISTRATION OF PET INSURANCE (U.S. CLS. 100, 101 AND 102).

BENJAMIN OKEKE, EXAMINING ATTORNEY

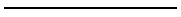

SN 85-173,241. FIFTH STREET CAPITAL LLC, WHITE PLAINS, NY. FILED 11-10-2010.

# WHERE PARTNERSHIP MEETS

THE MARK CONSISTS OF STANDARD CHARACTERS WITHOUT CLAIM TO ANY PARTICULAR FONT, STYLE, SIZE, OR COLOR.

FOR FINANCIAL SERVICES, NAMELY, FIRST LIEN, SECOND LIEN AND MEZZANINE FINANCING SERVICES; INVESTMENT SERVICES, NAMELY, INVESTMENT OF DEBT AND EQUITY TO SUPPORT BUSINESS EXPANSIONS, ACQUISITIONS, MANAGEMENT BUY-OUTS AND RECAPITALIZATIONS; AND INVESTMENT SERVICES, NAMELY, INVESTMENT OF DEBT AND EQUITY IN INVESTMENT VEHICLES, INCLUDING BUYOUT FUNDS (U.S. CLS. 100, 101 AND 102).

FIRST USE 11-16-2010; IN COMMERCE 11-16-2010.  
KAELIE KUNG, EXAMINING ATTORNEY

**CLASS 36—(Continued).**

SN 85-174,784. PIQUET, CRISTIANO, MIAMI, FL. FILED 11-11-2010.

# PIQUET REALTY

THE MARK CONSISTS OF STANDARD CHARACTERS WITHOUT CLAIM TO ANY PARTICULAR FONT, STYLE, SIZE, OR COLOR.

NO CLAIM IS MADE TO THE EXCLUSIVE RIGHT TO USE "REALTY", APART FROM THE MARK AS SHOWN.

FOR REAL ESTATE AGENCIES; REAL ESTATE BROKERAGE; REAL ESTATE CONSULTANCY (U.S. CLS. 100, 101 AND 102).

FIRST USE 10-0-2008; IN COMMERCE 10-0-2008.  
INGRID C. EULIN, EXAMINING ATTORNEY



SN 85-175,121. FEMFESSIONALS LLC, MIAMI, FL. FILED 11-11-2010.

# FEMFESSIONALLY FOCUSED, PHILANTHROPICALLY DRIVEN

THE MARK CONSISTS OF STANDARD CHARACTERS WITHOUT CLAIM TO ANY PARTICULAR FONT, STYLE, SIZE, OR COLOR.

FOR PHILANTHROPIC SERVICES CONCERNING MONETARY DONATIONS (U.S. CLS. 100, 101 AND 102).

ANDREA BUTLER, EXAMINING ATTORNEY



SN 85-175,227. PIQUET, CRISTIANO, MIAMI, FL. FILED 11-12-2010.

# PIQUET BANK

THE MARK CONSISTS OF STANDARD CHARACTERS WITHOUT CLAIM TO ANY PARTICULAR FONT, STYLE, SIZE, OR COLOR.

NO CLAIM IS MADE TO THE EXCLUSIVE RIGHT TO USE "BANK", APART FROM THE MARK AS SHOWN.

FOR BANKING; MORTGAGE BANKING; MORTGAGE BROKERAGE; MORTGAGE LENDING; MORTGAGE PROCUREMENT FOR OTHERS (U.S. CLS. 100, 101 AND 102).

INGRID C. EULIN, EXAMINING ATTORNEY

**CLASS 36—(Continued).**

SN 85-175,295. BANCO BILBAO VIZCAYA ARGENTARIA, S.A., BIBAO, SPAIN, FILED 11-12-2010.

**BBVA EAGLES**

THE MARK CONSISTS OF STANDARD CHARACTERS WITHOUT CLAIM TO ANY PARTICULAR FONT, STYLE, SIZE, OR COLOR.

FOR FINANCIAL ADVICE; FINANCIAL ASSET MANAGEMENT; FINANCIAL CONSULTING; SAVINGS BANK SERVICES (U.S. CLS. 100, 101 AND 102).  
LINDA E. BLOHM, EXAMINING ATTORNEY

**CLASS 36—(Continued).**

SN 85-175,818. OFFICE OF THE INDIANA STATE TREASURER, INDIANAPOLIS, IN. FILED 11-12-2010.



OWNER OF U.S. REG. NO. 3,847,494.

NO CLAIM IS MADE TO THE EXCLUSIVE RIGHT TO USE "THE DESIGN OF THE MAP OF THE STATE OF INDIANA", APART FROM THE MARK AS SHOWN.

THE COLOR(S) BLACK AND WHITE IS/ARE CLAIMED AS A FEATURE OF THE MARK.

THE MARK CONSISTS OF THE LETTERS "TRUST" IN BLACK, THE LETTERS "IN" IN WHITE OVERLAYING THE OUTLINE OF THE STATE OF INDIANA IN BLACK, AND THE LETTERS "DIANA" IN BLACK.

FOR FINANCIAL SERVICES, NAMELY, INVESTMENT ADVICE, INVESTMENT MANAGEMENT, INVESTMENT CONSULTATION AND INVESTMENT OF FUNDS FOR OTHERS, NAMELY, INVESTMENT PROGRAM FOR PARTICIPATING GOVERNMENTAL ENTITIES (U.S. CLS. 100, 101 AND 102).

FIRST USE 3-15-2008; IN COMMERCE 3-15-2008.

B. PARADEWELAI, EXAMINING ATTORNEY

SN 85-175,681. METROPOLITAN LIFE INSURANCE COMPANY, NEW YORK, NY. FILED 11-12-2010.

**WHERE YOU'RE NOT JUST COVERED, YOU'RE TRULY PROTECTED**

THE MARK CONSISTS OF STANDARD CHARACTERS WITHOUT CLAIM TO ANY PARTICULAR FONT, STYLE, SIZE, OR COLOR.

FOR INSURANCE AND FINANCIAL SERVICES, NAMELY, THE UNDERWRITING AND ADMINISTRATION OF HOME, AUTO, APARTMENT, CONDOMINIUM, BOAT, VACATION AND RENTAL PROPERTY, RECREATIONAL VEHICLE, PERSONAL EXCESS LIABILITY, LANDLORD TENANT, MOBILE HOME, MOTORCYCLE AND DWELLING FIRE INSURANCE COVERAGE (U.S. CLS. 100, 101 AND 102).

FIRST USE 4-1-2010; IN COMMERCE 4-1-2010.

JOHN DALIER, EXAMINING ATTORNEY

SN 85-176,533. PWA COALITION OF DALLAS, INC., DBA AIDS SERVICES OF DALLAS, DALLAS, TX. FILED 11-15-2010.



THE MARK CONSISTS OF A TIE INSIDE A CIRCLE WITH A DIAGONAL SLASH CROSSING OVER THE TIE.

FOR CHARITABLE FUNDRAISING SERVICES (U.S. CLS. 100, 101 AND 102).

ALICE BENMAMAN, EXAMINING ATTORNEY

**CLASS 36—(Continued).**

SN 85-176,545. PWA COALITION OF DALLAS, INC., DBA AIDS SERVICES OF DALLAS, DALLAS, TX. FILED 11-15-2010.

**NO TIE DINNER & DESSERT**

THE MARK CONSISTS OF STANDARD CHARACTERS WITHOUT CLAIM TO ANY PARTICULAR FONT, STYLE, SIZE, OR COLOR.  
FOR CHARITABLE FUNDRAISING SERVICES (U.S. CLS. 100, 101 AND 102).  
ALICE BENMAMAN, EXAMINING ATTORNEY

SN 85-176,879. CHOICE FINANCIAL GROUP, GRAFTON, ND. FILED 11-15-2010.

**CHOICETUNES**

THE MARK CONSISTS OF STANDARD CHARACTERS WITHOUT CLAIM TO ANY PARTICULAR FONT, STYLE, SIZE, OR COLOR.  
FOR BANKING SERVICES (U.S. CLS. 100, 101 AND 102).  
DOMINIC FATHY, EXAMINING ATTORNEY

SN 85-176,963. ATIVO CAPITAL MANAGEMENT LLC, CHICAGO, IL. FILED 11-15-2010.

**ATIVO**

THE MARK CONSISTS OF STANDARD CHARACTERS WITHOUT CLAIM TO ANY PARTICULAR FONT, STYLE, SIZE, OR COLOR.  
FOR INVESTMENT MANAGEMENT AND SECURITIES RESEARCH SERVICES (U.S. CLS. 100, 101 AND 102).  
FIRST USE 6-6-2006; IN COMMERCE 6-6-2006.  
WILLIAM P. SHANAHAN, EXAMINING ATTORNEY

**CLASS 36—(Continued).**

SN 85-177,381. GEORGE TUCKER LLC., SUNRISE BEACH, MO. FILED 11-16-2010.

**VACATION NATION**

THE MARK CONSISTS OF STANDARD CHARACTERS WITHOUT CLAIM TO ANY PARTICULAR FONT, STYLE, SIZE, OR COLOR.  
FOR LEASING OF REAL ESTATE (U.S. CLS. 100, 101 AND 102).  
EDWARD FENNESSY, EXAMINING ATTORNEY

SN 85-177,532. SUN BANCORP, INC., VINELAND, NJ. FILED 11-16-2010.

**C4 Business Banking**

THE MARK CONSISTS OF STANDARD CHARACTERS WITHOUT CLAIM TO ANY PARTICULAR FONT, STYLE, SIZE, OR COLOR.  
NO CLAIM IS MADE TO THE EXCLUSIVE RIGHT TO USE "BUSINESS BANKING", APART FROM THE MARK AS SHOWN.  
FOR BUSINESS BANKING SERVICES, NAMELY, CHECKING, SAVINGS, LOANS, ONLINE BANKING, FINANCING AND LEASEPURCHASE FINANCING, DEBIT AND CREDIT CARDS, EMPLOYEE BANKING SERVICES, FINANCIAL PLANNING AND INVESTMENT ADVISORY SERVICES (U.S. CLS. 100, 101 AND 102).  
GRETTA YAO, EXAMINING ATTORNEY

SN 85-177,577. MEDAMERICA INSURANCE COMPANY, ROCHESTER, NY. FILED 11-16-2010.

**MedAmerica FlexCare**

THE MARK CONSISTS OF STANDARD CHARACTERS WITHOUT CLAIM TO ANY PARTICULAR FONT, STYLE, SIZE, OR COLOR.  
FOR INSURANCE UNDERWRITING SERVICES IN THE FIELD OF LONG TERM CARE INSURANCE (U.S. CLS. 100, 101 AND 102).  
SUSAN STIGLITZ, EXAMINING ATTORNEY

**CLASS 36—(Continued).**

SN 85-177,966. WORLD WEAR PROJECT, LLC, DALLAS, TX. FILED 11-16-2010.



THE MARK CONSISTS OF A CLOTHES HANGER CONSISTING OF A PARTIAL RIBBON FOR THE HOOK OF THE HANGER AND A TRIANGLE FOR THE BODY OF THE HANGER. THE WORDS "CLOSETS FOR THE CAUSE" ARE POSITIONED BELOW THE DESIGN ELEMENT, WITH THE WORD "CLOSETS" PLACED ABOVE THE WORDS "FOR THE" AND THE WORD "CAUSE" PLACED BELOW THE WORDS "FOR THE".

FOR FUNDRAISING SERVICES, NAMELY, PARTNERING WITH NON-PROFIT ORGANIZATIONS TO COLLECT CLOTHING AND FOOTWEAR, AND PAYING THE ORGANIZATIONS FOR THE COLLECTED CLOTHING AND FOOTWEAR (U.S. CLS. 100, 101 AND 102).  
NICHOLAS COLEMAN, EXAMINING ATTORNEY

SN 85-178,112. FOOTHILLS ASSET MANAGEMENT, LTD., SCOTTSDALE, AZ. FILED 11-16-2010.

**SOUND ADVICE...YOUR BEST  
INVESTMENT**

THE MARK CONSISTS OF STANDARD CHARACTERS WITHOUT CLAIM TO ANY PARTICULAR FONT, STYLE, SIZE, OR COLOR.

FOR FINANCIAL SERVICES, NAMELY, INVESTMENT MANAGEMENT, INVESTMENT ADVICE, FUNDS INVESTMENT, INVESTMENT CONSULTATION AND INVESTMENT OF FUNDS FOR OTHERS (U.S. CLS. 100, 101 AND 102).

FIRST USE 4-1-2009; IN COMMERCE 4-1-2009.  
NAPOLEON SHARMA, EXAMINING ATTORNEY

**CLASS 36—(Continued).**

SN 85-178,289. SCHOOLSFIRST FEDERAL CREDIT UNION, SANTA ANA, CA. FILED 11-16-2010.

**BUILDING THE FUTURE FOR  
THOSE WHO BUILD THE FUTURE**

THE MARK CONSISTS OF STANDARD CHARACTERS WITHOUT CLAIM TO ANY PARTICULAR FONT, STYLE, SIZE, OR COLOR.

FOR CREDIT UNION SERVICES (U.S. CLS. 100, 101 AND 102).

RUSS HERMAN, EXAMINING ATTORNEY

SN 85-178,608. HOME ENTERTAINMENT DISTRIBUTORS, INC., DBA INSURERS WORLD, CANTON, MA. FILED 11-17-2010.

**JEM**

THE MARK CONSISTS OF STANDARD CHARACTERS WITHOUT CLAIM TO ANY PARTICULAR FONT, STYLE, SIZE, OR COLOR.

FOR INSURANCE ADMINISTRATION SERVICES, NAMELY, ASSISTING OTHERS WITH ADJUSTING INSURANCE CLAIMS (U.S. CLS. 100, 101 AND 102).

FIRST USE 0-0-2008; IN COMMERCE 0-0-2008.

JORDAN BAKER, EXAMINING ATTORNEY

SN 85-179,450. SAMANGO, ALFRED J., HALEIWA, HI. FILED 11-17-2010.

**FROM THIS TO THIS**

THE MARK CONSISTS OF STANDARD CHARACTERS WITHOUT CLAIM TO ANY PARTICULAR FONT, STYLE, SIZE, OR COLOR.

FOR ACCIDENT INSURANCE UNDERWRITING; ACQUISITION AND TRANSFER OF MONETARY CLAIMS; ADMINISTRATION OF EMPLOYEE BENEFIT PLANS CONCERNING INSURANCE AND FINANCE; ADMINISTRATION OF EMPLOYEE WELFARE BENEFIT PLANS CONCERNING INSURANCE AND FINANCE; ADVICE RELATING TO INVESTMENTS; ADVISING OTHERS CONCERNING INVESTMENTS IN INTELLECTUAL PROPERTY ASSETS AND INTANGIBLE BUSINESS ASSETS, BOTH DIRECTLY AND INDIRECTLY THROUGH OTHER ENTITIES; ADVISORY SERVICES IN THE FIELD OF EMPLOYEE BENEFITS FOR GROUP HEALTHCARE AND BUSINESS INSURANCE OFFERED TO EMPLOYEES IN ADDITION TO STANDARD BENEFITS SUCH AS MEDICAL, DENTAL, LIFE INSURANCE INCLUDING SHORT TERM DISABILITY, LONG TERM DISABILITY, CANCER INSURANCE, ACCIDENTAL DEATH AND DISMEMBERMENT; ADVISORY SERVICES RELATING TO CREDIT AND DEBIT CONTROL, INVESTMENT, GRANTS AND FINANCING OF LOANS; AGENCIES IN THE FIELD OF CREDIT FOR FARMING;

**CLASS 36—(Continued).**

AGRICULTURAL INSURANCE AGENCY SERVICES; ANNUITY SERVICES, NAMELY, ACCOUNT AND INVESTMENT ADMINISTRATION; ANNUITY SERVICES, NAMELY, ACCOUNT AND INVESTMENT ADMINISTRATION AND THE INVESTMENT AND DISTRIBUTION OF ANNUITY FUNDS; APPRAISAL AND EVALUATION OF REAL ESTATE; APPRAISAL OF REAL ESTATE; APPRAISALS FOR INSURANCE CLAIMS OF PERSONAL PROPERTY; APPRAISALS FOR INSURANCE CLAIMS OF REAL ESTATE; ARRANGING AND PROVISION OF CREDIT, LOANS, INSURANCE, CURRENCY EXCHANGE AND TRAVELLERS CHEQUES; ARRANGING OF LEASES AND RENTAL AGREEMENTS FOR REAL ESTATE; ASSESSING INSURANCE CLAIMS; ASSESSMENT AND MANAGEMENT OF REAL ESTATE; ASSUMING FINANCIAL RISK OF OTHERS BY ENTERING INTO OPTIONS AND SWAPS; ATM BANKING SERVICES; BANK TENDERING, NAMELY, TENDERING OF MONEY; BANKING; BANKING AND FINANCING SERVICES; BANKING CONSULTATION; BANKING SERVICES; BANKING SERVICES PROVIDED BY MOBILE TELEPHONE CONNECTIONS; BROKERAGE IN THE FIELD OF REAL ESTATE, INSURANCE, STOCKS AND COMMODITIES; BROKERAGE OF CARBON DIOXIDE AND OTHER GREENHOUSE GAS EMISSION CREDITS, ALLOWANCES OR OFFSETS ON BEHALF OF OFFSET PRODUCERS; BROKERAGE SERVICES FOR CAPITAL INVESTMENTS; BROKERAGE SERVICES IN THE FIELD OF SECURITIES AND COMMODITIES INVESTING; BUSINESS CREDIT REPORTING SERVICES; BUSINESS CREDIT VERIFICATION SERVICES; CAPITAL INVESTMENT CONSULTING; CAPITAL INVESTMENT SERVICES; CASH REPLACEMENT RENDERED BY CREDIT CARD; CHARGE CARD AND CREDIT CARD SERVICES; CLAIMS ADJUSTMENT IN THE FIELD OF INSURANCE; CLAIMS ADMINISTRATION SERVICES IN THE FIELD OF HEALTH INSURANCE; CLASSIFIED REAL ESTATE LISTINGS OF APARTMENT RENTALS AND HOUSING RENTALS; CLEARING AND RECONCILING FINANCIAL TRANSACTIONS VIA A GLOBAL COMPUTER NETWORK; COLLEGE CONSULTING SERVICES, NAMELY, ASSISTING STUDENTS IN APPLYING FOR SCHOLARSHIPS AND FINANCIAL AID; COLLEGE COUNSELING SERVICES, NAMELY, ASSISTING STUDENTS IN APPLYING FOR SCHOLARSHIPS AND FINANCIAL AID; COMMERCIAL AND RESIDENTIAL REAL ESTATE AGENCY SERVICES; COMMODITY INVESTMENT ADVICE; CONDUCTING FINANCIAL FEASIBILITY STUDIES; CONSULTANCY OF CAPITAL INVESTMENT; CONSULTATION IN ART AS AN INVESTMENT; CONSULTATION SERVICES IN THE FIELD OF FINANCIAL MANAGEMENT OF YACHT OPERATIONS; CONSULTATION, POLICY WRITING AND CLAIMS PROCESSING IN THE FIELD OF CROP INSURANCE; CONSULTING AND INFORMATION CONCERNING INSURANCE; CONSULTING ON THE SUBJECT OF INTELLECTUAL PROPERTY VALUATION; CONSULTING SERVICES IN THE FIELD OF STATE AND FEDERAL EMPLOYEE BENEFIT PLANS CONCERNING INSURANCE AND FINANCE; CONSUMER CREDIT CONSULTATION; COOPERATIVE CREDIT ORGANIZATIONS; CREDIT AGENCIES; CREDIT AGENCIES IN THE FIELD OF FARMING; CREDIT AND CASH CARD SERVICES; CREDIT AND DEBIT CARD SERVICES; CREDIT AND FINANCIAL CONSULTATION; CREDIT AND LOAN SERVICES; CREDIT BUREAUX; CREDIT BUREAUX; CREDIT CARD AND DEBIT CARD SERVICES; CREDIT CARD AND PAYMENT CARD SERVICES; CREDIT CARD AUTHORIZATION SERVICES; CREDIT CARD FACTORING SERVICES; CREDIT CARD PAYMENT PROCESSING SERVICES; CREDIT CARD SERVICES; CREDIT CARD TRANSACTION PROCESSING SERVICES; CREDIT CARD VERIFICATION; CREDIT CONSULTATION; CREDIT INQUIRY AND CONSULTATION; CREDIT RATING SERVICES; CREDIT RECOVERY AND COLLECTION; CREDIT REPORTING AGENCY; CREDIT REPORTING SERVICES; CREDIT RISK MANAGEMENT; CREDIT SCORING SERVICES; CREDIT UNION SERVICES; CREDIT UNION SERVICES PROVIDED BY MOBILE TELEPHONE CONNECTIONS; CREDIT UNIONS; CRUISE SHIP PROPERTY SERVICES, NAMELY, LISTING, LEASING, BROKERAGE, AND MANAGEMENT OF RESIDENTIAL AND COMMERCIAL UNITS ABOARD CRUISE SHIPS AND FINANCING OF SAME; DEBT CANCELLATION SERVICES USING PROCEEDS

**CLASS 36—(Continued).**

OF LIFE, DISABILITY AND UNEMPLOYMENT INSURANCE; DENTAL HEALTH INSURANCE ADMINISTRATION; DENTAL HEALTH INSURANCE UNDERWRITING AND ADMINISTRATION; ELECTRONIC BANKING VIA A GLOBAL COMPUTER NETWORK; ELECTRONIC CREDIT CARD TRANSACTIONS; ELECTRONIC FINANCIAL SERVICE FOR THE PURCHASE OF SAVINGS BONDS; ELECTRONIC FINANCIAL TRADING SERVICES; ELECTRONIC PROCESSING OF INSURANCE CLAIMS AND PAYMENT DATA; EQUITY CAPITAL INVESTMENT; EVALUATING REAL ESTATE TO ASSESS FEASIBILITY FOR USE AS A PROPERTY SELF-STORAGE FACILITY; EVALUATION OF CREDIT BUREAU DATA; EVALUATION OF REAL PROPERTY; EVALUATION OF THE CREDIT WORTHINESS OF COMPANIES AND PRIVATE INDIVIDUALS; FINANCIAL ADMINISTRATION OF A SCHOLARSHIP PROGRAM THAT PROMOTES EDUCATION THROUGH THE GRANTING OF SCHOLARSHIPS, THE RECIPIENTS BEING SELECTED IN LOCAL, STATE AND NATIONAL CONTESTS BASED ON SUCH FACTS AS SCHOLASTICS, TALENT, POISE AND FITNESS; FINANCIAL ADMINISTRATION OF RETIREMENT PLANS; FINANCIAL ADMINISTRATION OF SCHOLARSHIP PROGRAMS; FINANCIAL ADMINISTRATION OF STOCK EXCHANGE TRADING OF SHARES AND OTHER FINANCIAL SECURITIES IN FINANCIAL MARKETS; FINANCIAL ADMINISTRATION OF REAL ESTATE; FINANCIAL ADVICE; FINANCIAL ADVICE AND CONSULTANCY SERVICES; FINANCIAL ADVISORY AND CONSULTANCY SERVICES; FINANCIAL ADVISORY AND CONSULTANCY SERVICES RELATING TO MICRO CREDITS, MICRO FINANCE AND ENERGY PRODUCTS; FINANCIAL ADVISORY AND CONSULTANCY SERVICES, NAMELY, THE CREATION OF PERSONALIZED STRATEGIES TO ACHIEVE FINANCIAL INDEPENDENCE; FINANCIAL AFFAIRS AND MONETARY AFFAIRS, NAMELY, FINANCIAL INFORMATION, MANAGEMENT AND ANALYSIS SERVICES; FINANCIAL ANALYSES; FINANCIAL ANALYSIS AND CONSULTATION; FINANCIAL ANALYSIS AND RESEARCH SERVICES; FINANCIAL AND INVESTMENT SERVICES, NAMELY, MANAGEMENT AND BROKERAGE IN THE FIELDS OF STOCKS, BONDS, OPTIONS, COMMODITIES, FUTURES AND OTHER SECURITIES, AND THE INVESTMENT OF FUNDS OF OTHERS; FINANCIAL ASSET MANAGEMENT; FINANCIAL CALCULATION SERVICES FOR OTHERS, NAMELY, ROYALTY CALCULATION; FINANCIAL CLEARING HOUSES; FINANCIAL CONSULTANCY; FINANCIAL CONSULTANCY AND INSURANCE CONSULTANCY; FINANCIAL CONSULTANCY SERVICES IN THE AREA OF HEALTHCARE; FINANCIAL CONSULTATION; FINANCIAL CONSULTATION IN THE FIELD OF ENVIRONMENTAL MANAGEMENT, NAMELY, ADVISING BUSINESS AND INDIVIDUALS ON ISSUES OF PORTFOLIO PLANNING AND INVESTMENT PLANNING; FINANCIAL CONSULTATION IN THE FIELD OF FUELS, DIESEL FUEL, BIOFUEL AND BIODIESEL FUEL; FINANCIAL CONSULTING; FINANCIAL CONSULTING AND ADVISING IN THE FIELD OF MERGERS AND ACQUISITIONS; FINANCIAL CONSULTING IN THE FIELD OF REAL ESTATE NOTE BROKERAGE; FINANCIAL CONSULTING SERVICES IN THE FIELD OF PLANNED GIVING FOR NON-PROFIT AND CHARITABLE ORGANIZATIONS; FINANCIAL CONSULTING SERVICES, NAMELY, ADVISING OTHERS REGARDING INTELLECTUAL PROPERTY INVESTMENTS; FINANCIAL CONSULTING SERVICES, NAMELY, EXPERT ANALYSIS IN FINANCE; FINANCIAL COUNSELING SERVICES, NAMELY, HELPING OTHERS BUILD A BETTER WORKING RELATIONSHIP WITH THEIR MONEY; FINANCIAL CREDIT SCORING SERVICES; FINANCIAL DUE DILIGENCE; FINANCIAL DUE DILIGENCE SERVICES IN THE FIELD OF REAL ESTATE; FINANCIAL EVALUATION FOR INSURANCE PURPOSES; FINANCIAL EVALUATION, TRACKING, ANALYSIS, FORECASTING, CONSULTANCY, ADVISORY AND RESEARCH SERVICES RELATING TO SECURITIES AND OTHER FINANCIAL INSTRUMENTS; FINANCIAL EXCHANGE; FINANCIAL FORECASTING; FINANCIAL GUARANTEE AND SURETY; FINANCIAL GUARANTEES; FINANCIAL INFORMATION; FINANCIAL INFORMATION AND ADVISORY SERVICES; FINANCIAL INFORMATION AND EVALUATIONS; FINANCIAL INFORMATION IN THE NATURE OF RATES OF EXCHANGE; FINANCIAL INFORMATION

**CLASS 36—(Continued).**

PROCESSING; FINANCIAL INFORMATION PROVIDED BY ELECTRONIC MEANS; FINANCIAL INFORMATION SERVICES PROVIDED ON-LINE FROM A COMPUTER DATABASE OR A GLOBAL COMPUTER NETWORK, NAMELY, PROVIDING INFORMATION IN THE FIELD OF FINANCIAL CLASSIFICATION OF COMPANIES AND SECURITIES; FINANCIAL INVESTMENT ANALYSIS AND STOCK RESEARCH; FINANCIAL INVESTMENT BROKERAGE; FINANCIAL INVESTMENT BROKERAGE SERVICES; FINANCIAL INVESTMENT IN THE FIELD OF REAL ESTATE; FINANCIAL INVESTMENT SERVICES, NAMELY, ADMINISTERING THE ISSUANCE, UNDERWRITING AND DISTRIBUTION OF SECURITIES; FINANCIAL LOAN CONSULTATION; FINANCIAL MANAGEMENT; FINANCIAL MANAGEMENT OF YACHT OPERATIONS; FINANCIAL MANAGEMENT VIA THE INTERNET; FINANCIAL PLANNING; FINANCIAL PLANNING AND INVESTMENT ADVISORY SERVICES; FINANCIAL PLANNING CONSULTATION; FINANCIAL PLANNING FOR RETIREMENT; FINANCIAL PLANNING SERVICES, NAMELY, DEVELOPING AND MANAGING CHARITABLE GIVING PROGRAMS ON BEHALF OF WEALTHY INDIVIDUALS OR FAMILIES; FINANCIAL PLANNING, NAMELY, THE CREATION OF PERSONALIZED STRATEGIES TO ACHIEVE FINANCIAL INDEPENDENCE; FINANCIAL PORTFOLIO ANALYSIS SERVICES; FINANCIAL PORTFOLIO MANAGEMENT; FINANCIAL RESEARCH; FINANCIAL RESEARCH AND EQUITY RESEARCH BROKERAGE SERVICES; FINANCIAL RESEARCH AND INFORMATION SERVICES; FINANCIAL RESTRUCTURING SERVICES; FINANCIAL RISK MANAGEMENT; FINANCIAL RISK MANAGEMENT CONSULTATION; FINANCIAL SECURITIES EXCHANGE SERVICES; FINANCIAL SERVICES IN THE NATURE OF AN INVESTMENT SECURITY; FINANCIAL SERVICES RENDERED IN CONNECTION WITH THE ISSUANCE, RECEIPT AND TRANSFER OF LINES OF CREDIT, NAMELY, CREDIT PROCESSING SERVICES; FINANCIAL SERVICES, NAMELY, A TOTAL PORTFOLIO OFFERING FOR HIGH NET WORTH CLIENTS CONSISTING OF BOTH SEPARATE ACCOUNTS AND MUTUAL FUNDS FOR EQUITY AND FIXED INCOME INVESTMENTS; FINANCIAL SERVICES, NAMELY, ADMINISTRATION OF TRANSACTIONS INVOLVING FUNDS DRAWN FROM SECURITIES, STOCKS, FUNDS, EQUITIES, BONDS, CASH, OR OTHER TYPES OF FINANCIAL INVESTMENTS IN RETIREMENT PLANS USING A CHECK OR NEGOTIABLE ORDER OF WITHDRAWAL OVER A GLOBAL DATA NETWORK; FINANCIAL SERVICES, NAMELY, ADMINISTRATION OF TRANSACTIONS INVOLVING FUNDS DRAWN FROM SECURITIES, STOCKS, FUNDS, EQUITIES, BONDS, CASH, OR OTHER TYPES OF FINANCIAL INVESTMENTS IN RETIREMENT PLANS USING A CREDIT OR DEBIT CARD OVER A GLOBAL DATANETWORK; FINANCIAL SERVICES, NAMELY, ARRANGING OF MODIFIED LOAN TERMS DESIGNED TO PREVENT HOME FORECLOSURE; FINANCIAL SERVICES, NAMELY, ASSISTING OTHERS WITH THE COMPLETION OF FINANCIAL TRANSACTIONS FOR STOCKS, BONDS, SECURITIES AND EQUITIES; FINANCIAL SERVICES, NAMELY, BROKER/DEALER SERVICES ON SECURITIES EXCHANGES AND OVER-THE-COUNTER MARKETS; FINANCIAL SERVICES, NAMELY, BUSINESS FUNDRAISING FOR OTHERS; FINANCIAL SERVICES, NAMELY, BUSINESS FUNDRAISING PROVIDED OVER A COMPUTER NETWORK SUCH AS THE INTERNET; FINANCIAL SERVICES, NAMELY, COMMODITY TRADING AND MANAGED FUTURES ADVISORY AND MANAGEMENT SERVICES; FINANCIAL SERVICES, NAMELY, CONDUCTING A SECURITIES AND DERIVATIVES EXCHANGE; FINANCIAL SERVICES, NAMELY, COORDINATION, WITHIN A SINGLE ACCOUNT, OF AN INVESTMENT PORTFOLIO'S MAINTENANCE, TRADING, REBALANCING, AND TAX MANAGEMENT NEEDS; FINANCIAL SERVICES, NAMELY, CREDIT AGENCIES FEATURING CREDIT PROCESSING, NAMELY, CREDIT CHECKING, CREDIT ANALYZING, AND FINANCIAL REPORTING SERVICES; FINANCIAL SERVICES, NAMELY, CREDIT REPAIR AND RESTORATION; FINANCIAL SERVICES, NAMELY, DEALING IN SECURITIES AS A MARKET MAKER AND IN TRADING COMMODITIES, SECURITIES, OPTIONS, FUTURES, EQUITIES AND FIXED INCOME PRODUCTS IN THE U.S. AND OVERSEAS MARKET SECURITIES; FINANCIAL SERVICES,

**CLASS 36—(Continued).**

NAMELY, DEBT RESOLUTION SERVICES IN THE NATURE OF DEBT SETTLEMENT AND ELIMINATION; FINANCIAL SERVICES, NAMELY, DEBT SETTLEMENT; FINANCIAL SERVICES, NAMELY, ELECTRONIC REMOTE CHECK DEPOSIT SERVICES; FINANCIAL SERVICES, NAMELY, ESTATE SETTLEMENT SERVICES; FINANCIAL SERVICES, NAMELY, FUNDING ONLINE CASH ACCOUNTS FROM PREPAID CASH CARDS, BANK ACCOUNTS AND CREDIT CARD ACCOUNTS; FINANCIAL SERVICES, NAMELY, FUNDING RESEARCH AWARDS IN THE FIELD OF ENERGY; FINANCIAL SERVICES, NAMELY, GOLD TRADING; FINANCIAL SERVICES, NAMELY, INVESTMENT ADVICE, INVESTMENT MANAGEMENT, INVESTMENT CONSULTATION AND INVESTMENT OF FUNDS FOR OTHERS, INCLUDING PRIVATE AND PUBLIC EQUITY AND DEBT INVESTMENT SERVICES; FINANCIAL SERVICES, NAMELY, INVESTMENT FUND TRANSFER AND TRANSACTION SERVICES; FINANCIAL SERVICES, NAMELY, ISSUANCE AND MANAGEMENT OF CERTIFICATES BACKED BY LOAN PORTFOLIOS WHICH ARE SUBSEQUENTLY MANAGED TO INSURE THE INTEGRITY OF THE CERTIFICATES; FINANCIAL SERVICES, NAMELY, LIFE INSURANCE SETTLEMENT SERVICES; FINANCIAL SERVICES, NAMELY, LOAN DEFAULT MITIGATION SERVICES; FINANCIAL SERVICES, NAMELY, LOSS MITIGATION SERVICES FOR UNDER- OR NON-PERFORMING MORTGAGE LOANS; FINANCIAL SERVICES, NAMELY, MONEY LENDING; FINANCIAL SERVICES, NAMELY, MORTGAGE PLANNING; FINANCIAL SERVICES, NAMELY, MORTGAGE REFINANCING; FINANCIAL SERVICES, NAMELY, PROPRIETARY TRADING IN COMMODITIES, SECURITIES, OPTIONS, FUTURES, EQUITIES AND FIXED INCOME PRODUCTS IN THE U.S. AND OVERSEAS MARKET SECURITIES; FINANCIAL SERVICES, NAMELY, PROVIDING A VIRTUAL CURRENCY FOR USE BY MEMBERS OF AN ON-LINE COMMUNITY VIA A GLOBAL COMPUTER NETWORK; FINANCIAL SERVICES, NAMELY, PROVIDING AN INVESTMENT OPTION AVAILABLE FOR VARIABLE ANNUITY AND VARIABLE LIFE INSURANCE PRODUCTS; FINANCIAL SERVICES, NAMELY, PROVIDING FOR THE EXCHANGE OF FOREIGN CURRENCY, COMMODITIES, FINANCIAL DERIVATIVES, INTEREST RATE PRODUCTS, AND EQUITIES VIA THE INTERNET AND INTRANET SYSTEMS; FINANCIAL SERVICES, NAMELY, PROVIDING INFORMATION IN THE FIELDS OF FOREIGN CURRENCY, COMMODITIES, FINANCIAL DERIVATIVES, INTEREST RATE PRODUCTS, AND EQUITIES VIA THE INTERNET AND INTRANET SYSTEMS; FINANCIAL SERVICES, NAMELY, PROVIDING ON-LINE STORED VALUE ACCOUNTS IN AN ELECTRONIC ENVIRONMENT; FINANCIAL SERVICES, NAMELY, RAISING DEBT AND EQUITY CAPITAL FOR OTHERS; FINANCIAL SERVICES, NAMELY, RAISING MONEY FOR THE HEDGE FUNDS OF OTHERS; FINANCIAL SERVICES, NAMELY, REAL ESTATE NOTE BROKERAGE; FINANCIAL SERVICES, NAMELY, SAVINGS PROGRAMS FOR YOUTHS; FINANCIAL SERVICES, NAMELY, THE PURCHASE OF RESIDENTIAL MORTGAGES ON BEHALF OF OTHERS AND THE ISSUANCE OF MORTGAGE-BACKED SECURITIES; FINANCIAL SERVICES, NAMELY, THE TRADING OF FINANCIAL INSTRUMENTS, SECURITIES, SHARES, OPTIONS AND OTHER DERIVATIVE PRODUCTS; FINANCIAL SERVICES, NAMELY, WEALTH MANAGEMENT SERVICES; FINANCIAL TRANSACTION SERVICES, NAMELY, PROVIDING SECURE COMMERCIAL TRANSACTIONS AND PAYMENT OPTIONS; FINANCIAL TRANSACTION SERVICES, NAMELY, PROVIDING SECURE COMMERCIAL TRANSACTIONS AND PAYMENT OPTIONS USING A MOBILE DEVICE AT A POINT OF SALE; FINANCIAL TRUST OPERATIONS; FINANCIAL TRUST PLANNING; FINANCIAL VALUATION OF PERSONAL PROPERTY AND REAL ESTATE; FINANCIAL VALUATIONS; FINANCIALLY-GUARANTEED FINANCING; FINANCING OF REAL ESTATE DEVELOPMENT PROJECTS; FIRE INSURANCE UNDERWRITING; FRAUD REIMBURSEMENT SERVICES IN THE FIELD OF CREDIT CARD PURCHASES; FUND INVESTMENT CONSULTATION; FUND INVESTMENT SERVICES FEATURING SECURITIES OFFERED ACCORDING TO PREVIOUSLY ESTABLISHED CRITERIA IN ORDER TO MAINTAIN A PREDETERMINED LEVEL OF PAYMENTS TO THE ACCOUNT HOLDER; FUND INVESTMENT SERVICES FEATURING THE

**CLASS 36—(Continued).**

TRADING OF AN ACCOUNT HOLDER'S SECURITIES ACCORDING TO PREVIOUSLY ESTABLISHED CRITERIA IN ORDER TO MAINTAIN A PREDETERMINED LEVEL OF PAYMENTS TO THE ACCOUNT HOLDER; FUNDS INVESTMENT; GLOBAL INVESTMENT RESEARCH SERVICES; HEALTH INSURANCE UNDERWRITING; HEALTHCARE INSURANCE SERVICES FOR LASIK SURGERY; HEDGE FUND INVESTMENT SERVICES; HOME BANKING; HOUSING SERVICES, NAMELY, REAL PROPERTY ACQUISITION AND CONSUMER FINANCING TO FACILITATE HOME OWNERSHIP; INFORMATION, ADVISORY, CONSULTANCY AND RESEARCH SERVICES RELATING TO FINANCE AND INVESTMENTS; INSURANCE ACTUARIAL SERVICES; INSURANCE ADMINISTRATION; INSURANCE ADMINISTRATION SERVICES, NAMELY, ASSISTING OTHERS WITH ADJUSTING INSURANCE CLAIMS; INSURANCE ADMINISTRATION SERVICES, NAMELY, ASSISTING OTHERS WITH COLLECTING INSURANCE PREMIUMS; INSURANCE AGENCIES; INSURANCE AGENCY AND BROKERAGE; INSURANCE AND FINANCIAL INFORMATION AND CONSULTANCY SERVICES; INSURANCE BROKERAGE; INSURANCE BROKERAGE IN THE FIELD OF PRIZE INDEMNITY; INSURANCE BROKERAGE SERVICES; INSURANCE CARRIER SERVICES; INSURANCE CLAIMS ADMINISTRATION; INSURANCE CLAIMS PROCESSING; INSURANCE CONSULTANCY; INSURANCE CONSULTANCY SERVICES, NAMELY, PROVIDING ADVICE IN THE FIELD OF PROPERTY AND CASUALTY INSURANCE; INSURANCE CONSULTATION; INSURANCE INFORMATION; INSURANCE INFORMATION AND CONSULTANCY; INSURANCE PREMIUM RATE COMPUTING; INSURANCE SERVICES IN THE NATURE OF LOSS CONTROL MANAGEMENT FOR OTHERS; INSURANCE SERVICES, NAMELY, PROVIDING INDEPENDENT SCORING SERVICE RELATED TO EXISTING MEDICAL SERVICES IN A SPECIFIC GEOGRAPHIC REGION FOR INSURANCE EVALUATION PURPOSES; INSURANCE SERVICES, NAMELY, PROVIDING INFORMATION AND ON-LINE COMPUTER DATABASES FOR THE PURPOSE OF REVIEW AND VERIFICATION OF MEDICAID AND MEDICARE ELIGIBILITY STATUS AND RELATED INFORMATION; INSURANCE SERVICES, NAMELY, PROVIDING INFORMATION AND ON-LINE COMPUTER DATABASES FOR THE PURPOSE OF REVIEW AND VERIFICATION OF MEDICAID ELIGIBILITY STATUS AND RELATED INFORMATION; INSURANCE SERVICES, NAMELY, PROVIDING INFORMATION AND ON-LINE COMPUTER DATABASES FOR THE PURPOSE OF REVIEW AND VERIFICATION OF MEDICARE ELIGIBILITY STATUS AND RELATED INFORMATION; INSURANCE SERVICES, NAMELY, UNDERWRITING, ISSUING AND ADMINISTRATION OF LIFE INSURANCE; INSURANCE SERVICES, NAMELY, VIATICAL SETTLEMENT SERVICES, LIFE SETTLEMENT SERVICES FOR INSURANCE POLICYHOLDERS, AND SENIOR SETTLEMENT SERVICES FOR INSURANCE POLICYHOLDERS; INSURANCE SERVICES, NAMELY, WRITING MULTI-PERIL CROP INSURANCE, CROP HAIL INSURANCE AND REINSURANCE UNDERWRITING IN THE FIELDS OF CROP AND INTERNATIONAL BUSINESS; INSURANCE SERVICES, NAMELY, WRITING PROPERTY AND CASUALTY INSURANCE; INSURANCE SUBROGATION AND SALVAGE; INSURANCE UNDERWRITING CONSULTATION; INSURANCE UNDERWRITING SERVICES FOR ALL TYPES OF INSURANCE; INTELLECTUAL PROPERTY VALUATION SERVICES; INTELLECTUAL PROPERTY VENTURE FUND DEVELOPMENT AND FORMATION SERVICES FOR OTHERS; INTELLECTUAL PROPERTY VENTURE FUND MANAGEMENT SERVICES; INVESTMENT ADVICE; INVESTMENT ADVISORY SERVICES; INVESTMENT BANKING SERVICES; INVESTMENT BANKING SERVICES IN THE FIELD OF EMPLOYEE STOCK OWNERSHIP PLANS (ESOP); INVESTMENT BROKERAGE; INVESTMENT BY ELECTRONIC MEANS; INVESTMENT CLUBS; INVESTMENT CONSULTANCY; INVESTMENT CONSULTATION; INVESTMENT MANAGEMENT; INVESTMENT MANAGEMENT OF AND DISTRIBUTION OF ANNUITIES; INVESTMENT MANAGEMENT OF AND DISTRIBUTION OF VARIABLE ANNUITIES; INVESTMENT MANAGEMENT SERVICES IN THE FIELD OF ACQUIRING JOINT VENTURES; INVESTMENT OF FUNDS FOR OTHERS; INVESTMENT SERVICES, NAMELY, ASSET ACQUISITION, CONSULTATION, DEVELOPMENT AND

**CLASS 36—(Continued).**

MANAGEMENT SERVICES; ISSUANCE OF BANK CHECKS; ISSUANCE OF CREDIT CARDS; ISSUING CREDIT CARDS; ISSUING OF BANK CHEQUES; ISSUING OF CHECKS AND LETTERS OF CREDIT; ISSUING OF CREDIT CARDS; ISSUING OF LETTERS OF CREDIT; ISSUING OF TRAVELLERS' CHEQUES AND LETTERS OF CREDIT; LAND ACQUISITION, NAMELY, REAL ESTATE BROKERAGE; LEASE OF REAL ESTATE; LEASING OF REAL ESTATE; LEASING OF REAL PROPERTY; LEVERAGED BUY OUTS AND INVESTMENTS IN FINANCIALLY DISTRESSED OR UNDERPERFORMING COMPANIES; LIFE INSURANCE BROKERAGE; LIFE INSURANCE UNDERWRITING; MAINTAINING ESCROW ACCOUNTS FOR INVESTMENTS; MANAGEMENT OF A CAPITAL INVESTMENT FUND; MARINE ACCIDENTS INSURANCE UNDERWRITING; MARINE FIRE INSURANCE UNDERWRITING; MARINE INSURANCE UNDERWRITING; MARINE TRANSPORTATION INSURANCE UNDERWRITING; MEDICAL INSURANCE UNDERWRITING; MEMBERSHIP CLUB SERVICES, NAMELY, PROVIDING INFORMATION TO MEMBERS IN THE FIELDS OF REAL ESTATE, MORTGAGES AND DEBT ELIMINATION; MERCHANT BANKING AND INVESTMENT BANKING SERVICES; MERCHANT BANKING SERVICES; MONETARY EXCHANGE; MONETARY EXCHANGE OPERATIONS; MONETARY STRATEGY CONSULTATION AND RESEARCH; MORTGAGE BANKING; MORTGAGE BANKING SERVICES, NAMELY, ORIGINATION, ACQUISITION, SERVICING, SECURITIZATION AND BROKERAGE OF MORTGAGE LOANS; MORTGAGE COMPLIANCE CONSULTING SERVICES CONCERNING FINANCIAL REQUIREMENTS FOR MORTGAGES FOR MORTGAGE LENDERS AND SERVICERS AND MORTGAGE BROKERS; MORTGAGE FORECLOSURE MITIGATION AND LOAN DEFAULT MITIGATION SERVICES, NAMELY, ACQUISITION AND LEASE-BACK OF REAL ESTATE; MORTGAGE SERVICES, NAMELY, BUYER PREQUALIFICATION OF MORTGAGES FOR MORTGAGE BROKERS AND BANKS; MUTUAL FUND INVESTMENT; MUTUAL FUNDS AND CAPITAL INVESTMENT; NEWS REPORTING SERVICES IN THE FIELD OF FINANCIAL NEWS; ON-LINE BANKING SERVICES; ON-LINE FINANCIAL PLANNING SERVICES; ON-LINE REAL-TIME CURRENCY TRADING; ON-LINE TRADING OF FINANCIAL INSTRUMENTS, SHARES, OPTIONS AND OTHER DERIVATIVE PRODUCTS; ONLINE, REAL-TIME TAX PAYMENT PROCESSING, TAX PAYMENT MANAGEMENT, AND TAX PAYMENT ANALYSIS SERVICES; ORGANIZATION OF ONLINE STOCK EXCHANGES FOR THE BENEFIT OF THE TRADE OF STOCKS AND OTHER FINANCIAL SECURITIES; ORGANIZATION OF STOCK EXCHANGES FOR THE BENEFIT OF THE TRADE OF STOCKS AND OTHER FINANCIAL VALUES; PAYMENT PROCESSING SERVICES, NAMELY, CREDIT CARD AND DEBIT CARD TRANSACTION PROCESSING SERVICES; PHILANTHROPIC SERVICES, NAMELY, FINANCIAL ENDOWMENT OF; PRIVATE EQUITY FUND INVESTMENT SERVICES; PROCESSING, ADMINISTERING AND MANAGING EMPLOYEE BENEFIT PLANS CONCERNING INSURANCE AND FINANCE; PROVIDING A DATABASE FOR TRACKING, MONITORING, AND GENERATING REPORTS ON INFORMATION AND STATISTICS ABOUT PATIENT REIMBURSEMENT AND INSURANCE COVERAGE FOR PHARMACEUTICALS AND MEDICAL DEVICES; PROVIDING A DATABASE OF INFORMATION ABOUT RESIDENTIAL REAL ESTATE LISTINGS IN DIFFERENT NEIGHBORHOODS AND COMMUNITIES; PROVIDING A DATABASE OF RESIDENTIAL REAL ESTATE LISTINGS WITHIN NEIGHBORHOODS AND COMMUNITIES SPECIFICALLY IDENTIFIED BY USERS; PROVIDING A WEB SITE FEATURING PERSONAL FINANCIAL INFORMATION AND FINANCIAL ADVICE; PROVIDING A WEB SITE THAT ASSISTS FINANCIAL PROFESSIONALS IN THE MANAGEMENT OF RETIREMENT ACCOUNTS; PROVIDING A WEB SITE WHERE USERS CAN POST RATINGS, REVIEWS AND RECOMMENDATIONS ON STOCKS, BONDS, MUTUAL FUNDS AND OTHER FINANCIAL INSTRUMENTS; PROVIDING A WEBSITE FEATURING NON-DOWNLOADABLE VIDEOS IN THE FIELD OF FINANCIAL PLANNING; PROVIDING AN INTERNET WEBSITE PORTAL OFFERING INFORMATION IN THE FIELDS OF REAL ESTATE CONCERNING THE PURCHASE AND SALE OF NEW AND RESALE

**CLASS 36—(Continued).**

HOMES AND CONDOS; PROVIDING BANK ACCOUNT INFORMATION BY TELEPHONE; PROVIDING CASH AND OTHER REBATES FOR CREDIT CARD USE AS PART OF A CUSTOMER LOYALTY PROGRAM; PROVIDING ELECTRONIC PROCESSING OF ACH AND CREDIT CARD TRANSACTIONS AND ELECTRONIC PAYMENTS VIA A GLOBAL COMPUTER NETWORK; PROVIDING ELECTRONIC PROCESSING OF CREDIT CARD TRANSACTIONS AND ELECTRONIC PAYMENTS VIA A GLOBAL COMPUTER NETWORK; PROVIDING ELECTRONIC PROCESSING OF ELECTRONIC FUNDS TRANSFER, ACH, CREDIT CARD, DEBIT CARD, ELECTRONIC CHECK AND ELECTRONIC PAYMENTS; PROVIDING EMERGENCY FINANCIAL ASSISTANCE FOR INDIVIDUALS AND FAMILIES; PROVIDING FINANCIAL ASSESSMENTS OF DAMAGES AFTER A DISASTER; PROVIDING FINANCIAL INFORMATION; PROVIDING FINANCIAL RISK MANAGEMENT SERVICES FOR ELECTRONIC FUNDS TRANSFER, CREDIT AND DEBIT CARD AND ELECTRONIC CHECK TRANSACTIONS VIA A GLOBAL COMPUTER NETWORK; PROVIDING FINANCIAL SERVICES WITH RESPECT TO SECURITIES AND OTHER FINANCIAL INSTRUMENTS AND PRODUCTS, NAMELY, MONEY MANAGEMENT SERVICES; PROVIDING FINANCIAL SERVICES WITH RESPECT TO SECURITIES AND OTHER FINANCIAL INSTRUMENTS AND PRODUCTS, NAMELY, PROVIDING FINANCIAL MARKET NEWS AND COMMENTARY; PROVIDING FINANCIAL SERVICES WITH RESPECT TO SECURITIES AND OTHER FINANCIAL INSTRUMENTS AND PRODUCTS, NAMELY, TRADING OF AND INVESTMENTS IN SECURITIES AND FINANCIAL INSTRUMENTS AND PRODUCTS FOR OTHERS; PROVIDING INFORMATION AND ADVICE IN THE FIELD OF FINANCE, FINANCIAL INVESTMENTS, FINANCIAL VALUATIONS, AND THE FINANCIAL ASPECTS OF RETIREMENT; PROVIDING INFORMATION AND RESEARCH IN THE FIELD OF FINANCE AND FINANCIAL INVESTMENTS; PROVIDING INFORMATION IN INSURANCE MATTERS; PROVIDING INFORMATION IN THE FIELD OF FINANCIAL STOCK AND EQUITY MARKETS; PROVIDING INFORMATION IN THE FIELD OF REAL ESTATE BY MEANS OF LINKING THE WEB SITE TO OTHER WEB SITES FEATURING REAL ESTATE INFORMATION; PROVIDING INFORMATION IN THE FIELD OF REAL ESTATE VIA THE INTERNET; PROVIDING INFORMATION ON GOVERNMENT FINANCIAL ASSISTANCE PROGRAMS; PROVIDING INFORMATION REGARDING POLICY RATES FOR ALL TYPES OF INSURANCE AND ELECTRONIC PROCESSING OF INSURANCE CLAIMS AND PAYMENT DATA OVER A WEB BASED COMPUTER NETWORK; PROVIDING INFORMATION REGARDING WORKERS' COMPENSATION INSURANCE POLICY RATES; PROVIDING INVESTORS WITH FINANCIAL INFORMATION; PROVIDING MONETARY EXCHANGE SERVICES, NAMELY, EXCHANGING GOLD OF OTHERS FOR CASH; PROVIDING MONETARY EXCHANGE SERVICES, NAMELY, EXCHANGING VEHICLES OF OTHERS FOR CASH; PROVIDING ON-LINE FINANCIAL CALCULATORS; PROVIDING ON-LINE INFORMATION IN THE FIELD OF CHARITABLE MONETARY GIVING THROUGH FINANCIAL AND ESTATE PLANNING; PROVIDING POST-COMPLIANCE FINANCIAL REVIEWS FOR THE MORTGAGE INDUSTRY; PROVIDING REAL ESTATE LISTINGS AND REAL ESTATE INFORMATION VIA THE INTERNET; PROVIDING REAL ESTATE LISTINGS VIA THE INTERNET; PROVIDING VEHICLE INSURANCE RATE QUOTES; PROVISION AND FINANCIAL ADMINISTRATION OF A DEBIT CARD SAVINGS PROGRAM; PROVISION OF A FINANCIAL EXCHANGE FOR THE TRADING OF SECURITIES, SHARES AND OPTIONS AND OTHER DERIVATIVE PRODUCTS; PROVISION OF FINANCIAL INFORMATION; PROVISION OF FINANCIAL INFORMATION RELATING TO THE FINANCE INDUSTRY INVOLVED IN ENVIRONMENTALLY FOCUSED INVESTMENTS; PUBLIC EQUITY INVESTMENT MANAGEMENT; REAL ESTATE ACQUISITION SERVICES; REAL ESTATE AGENCIES; REAL ESTATE APPRAISAL; REAL ESTATE APPRAISAL AND VALUATION; REAL ESTATE BROKERAGE; REAL ESTATE BROKERAGE SERVICES SPECIALIZING IN RESTAURANTS AND OTHER FOOD SERVICE RELATED BUSINESSES; REAL ESTATE CONSULTANCY; REAL ESTATE CONSULTATION; REAL ESTATE EQUITY SHARING, NAMELY,

**CLASS 36—(Continued).**

MANAGING AND ARRANGING FOR CO-OWNERSHIP OF REAL ESTATE; REAL ESTATE ESCROW SERVICES; REAL ESTATE FINANCING SERVICES; REAL ESTATE FUNDS INVESTMENT SERVICES; REAL ESTATE INSURANCE UNDERWRITING SERVICES; REAL ESTATE INVESTMENT SERVICES; REAL ESTATE INVESTMENT SERVICES IN THE NATURE OF PURCHASING AND SELLING OF REAL ESTATE FOR OTHERS; REAL ESTATE INVESTMENT TRUST ADVISORY SERVICES; REAL ESTATE INVESTMENT TRUST MANAGEMENT SERVICES; REAL ESTATE INVESTMENT TRUST SERVICES; REAL ESTATE LENDING SERVICES; REAL ESTATE LISTING; REAL ESTATE LISTING SERVICES FOR HOUSING RENTALS AND APARTMENT RENTALS; REAL ESTATE MANAGEMENT CONSULTATION; REAL ESTATE MANAGEMENT OF VACATION HOMES; REAL ESTATE MANAGEMENT SERVICES; REAL ESTATE MULTIPLE LISTING SERVICES; REAL ESTATE PROCUREMENT FOR OTHERS; REAL ESTATE RENTAL SERVICES, NAMELY, RENTAL OF RESIDENTIAL HOUSING; REAL ESTATE SERVICE, NAMELY, RENTAL PROPERTY MANAGEMENT; REAL ESTATE SERVICES IN THE FORM OF PROVIDING PHYSICAL ACCESS TO AVAILABLE PROPERTIES VIA A REMOTE CALL-IN LOCKING DEVICE; REAL ESTATE SERVICES TO STOP FORECLOSURE, NAMELY, MORTGAGE DEBT MANAGEMENT; REAL ESTATE SERVICES, NAMELY, AD VALOREM APPRAISALS; REAL ESTATE SERVICES, NAMELY, CONDOMINIUM MANAGEMENT SERVICES; REAL ESTATE SERVICES, NAMELY, LEASING AND MANAGEMENT FOR OTHERS OF RESIDENTIAL CONDOMINIUMS LOCATED WITHIN HOTEL DEVELOPMENTS; REAL ESTATE SERVICES, NAMELY, MASS APPRAISALS; REAL ESTATE SERVICES, NAMELY, PROPERTY MANAGEMENT SERVICES FOR CONDOMINIUM ASSOCIATIONS, HOMEOWNER ASSOCIATIONS AND APARTMENT BUILDINGS; REAL ESTATE SERVICES, NAMELY, PROVIDING ONLINE QUESTIONS TO HELP USERS DETERMINE THE BEST NEIGHBORHOODS AND COMMUNITIES SUITED TO THEIR INDIVIDUAL NEEDS AND PREFERENCES; REAL ESTATE SERVICES, NAMELY, RENTAL OF SHORT-TERM FURNISHED APARTMENTS; REAL ESTATE SERVICES, NAMELY, RENTAL OF VACATION HOMES; REAL ESTATE SERVICES, NAMELY, RENTAL OF VACATION HOMES, CONDOMINIUMS, CABINS, AND VILLAS USING PAY PER CLICK ADVERTISING ON A GLOBAL COMPUTER NETWORK; REAL ESTATE SERVICES, NAMELY, RENTAL, BROKERAGE, LEASING AND MANAGEMENT OF COMMERCIAL PROPERTY, OFFICES AND OFFICE SPACE; REAL ESTATE SERVICES, NAMELY, TAX APPRAISALS; REAL ESTATE SERVICES, NAMELY, VACATION HOME RENTAL MANAGEMENT SERVICES; REAL ESTATE SYNDICATION; REAL ESTATE TIME-SHARING; REAL ESTATE TRUSTEE SERVICES; REAL ESTATE VALUATION SERVICES; REAL ESTATE VALUATIONS; REAL PROPERTY REAPPRAISAL SERVICES; REPAIR COST EVALUATION; SAVINGS BANK SERVICES; SAVINGS BANKS; SECURITIES TRADING AND INVESTING SERVICES FOR OTHERS VIA THE INTERNET; STRATEGIC CORPORATE FINANCIAL ADVISORY SERVICES; STRATEGIC FINANCIAL ADVISORY SERVICES; TELEPHONE BANKING SERVICES; TRADING OF CARBON DIOXIDE AND GREENHOUSE GAS EMISSION CREDITS, ALLOWANCES OR OFFSETS OF OTHERS; TRANSFER AGENCY SERVICES RENDERED TO ISSUERS OF INVESTMENT SECURITIES; TRUST SERVICES, NAMELY, INVESTMENT AND TRUST COMPANY SERVICES; UNDERWRITING AND ADMINISTRATION OF COMMERCIAL COLLATERAL LIABILITY INSURANCE; UNDERWRITING INSURANCE FOR PRE-PAID HEALTH CARE; UNDERWRITING INSURANCE FOR PRE-PAID LEGAL SERVICES; VACATION REAL ESTATE TIME SHARE EXCHANGE SERVICES; VACATION REAL ESTATE TIME-SHARING; VACATION REAL ESTATE TIMESHARE SERVICES; VALUATIONS IN REAL ESTATE MATTERS; WEBSITE FOR CHILDREN WITH PARENTAL CONTROLS THAT PROMOTES AND FACILITATES FINANCIAL GOAL SETTING (U.S. CLS. 100, 101 AND 102).

GIANCARLO CASTRO, EXAMINING ATTORNEY



**CLASS 36—(Continued).**

SN 85-179,575. QUICKBRIDGE (UK) LIMITED, LONDON, UNITED KINGDOM, FILED 11-18-2010.



THE MARK CONSISTS OF A DIALOGUE BOX WITH THE STYLIZED WORDS WONGA.COM APPEARING IN THE BOX.

FOR FINANCIAL SERVICES, NAMELY, MONEY LENDING; FINANCING AND LOAN SERVICES (U.S. CLS. 100, 101 AND 102).

ANN E. SAPPENFIELD, EXAMINING ATTORNEY

**CLASS 36—(Continued).**

SN 85-181,232. WORLD RELIEF CORPORATION OF NATIONAL ASSOCIATION OF EVANGELICALS, BALTIMORE, MD. FILED 11-19-2010.

**STAND/FOR THE VULNERABLE**

THE MARK CONSISTS OF THE WORDS STAND/FOR THE VULNERABLE IN A STYLIZED FORMAT WITH AN UPSIDE DOWN "V" FOR THE "A" IN STAND.

FOR CHARITABLE FUND-RAISING SERVICES (U.S. CLS. 100, 101 AND 102).

FIRST USE 9-18-2010; IN COMMERCE 9-18-2010.

KATHERINE E. HALMEN, EXAMINING ATTORNEY

SN 85-180,534. WORLD RELIEF CORPORATION OF NATIONAL ASSOCIATION OF EVANGELICALS, BALTIMORE, MD. FILED 11-18-2010.



OWNER OF U.S. REG. NOS. 2,251,349 AND 2,270,515. THE MARK CONSISTS OF FOUR STYLIZED HAND SYMBOLS THAT CREATE A "PINWHEEL" DESIGN. FOR CHARITABLE FUND-RAISING SERVICES (U.S. CLS. 100, 101 AND 102).

FIRST USE 9-18-2010; IN COMMERCE 9-18-2010.

KATHERINE E. HALMEN, EXAMINING ATTORNEY

SN 85-183,019. QUICKBRIDGE (UK) LIMITED, LONDON, UNITED KINGDOM, FILED 11-22-2010.

**WONGA.COM**

THE MARK CONSISTS OF STANDARD CHARACTERS WITHOUT CLAIM TO ANY PARTICULAR FONT, STYLE, SIZE, OR COLOR.

FOR FINANCIAL SERVICES, NAMELY, MONEY LENDING; FINANCING AND LOAN SERVICES (U.S. CLS. 100, 101 AND 102).

ANN E. SAPPENFIELD, EXAMINING ATTORNEY

SN 85-181,223. TRACEY, ROBERT J., BROOKLYN, NY. FILED 11-19-2010.

**START PACKING WHEN YOU LIST WITH TRACEY REAL ESTATE!**

THE MARK CONSISTS OF STANDARD CHARACTERS WITHOUT CLAIM TO ANY PARTICULAR FONT, STYLE, SIZE, OR COLOR.

FOR REAL ESTATE BROKERAGE (U.S. CLS. 100, 101 AND 102).

ARETHA SOMERVILLE, EXAMINING ATTORNEY

SN 85-197,450. LYNDON PROPERTY INSURANCE COMPANY, CHESTERFIELD, MO. FILED 12-14-2010.

**TOUCHPOINTE SECURE PLANS**

THE MARK CONSISTS OF STANDARD CHARACTERS WITHOUT CLAIM TO ANY PARTICULAR FONT, STYLE, SIZE, OR COLOR.

NO CLAIM IS MADE TO THE EXCLUSIVE RIGHT TO USE "SECURE PLANS", APART FROM THE MARK AS SHOWN.

FOR FACILITATING AND ARRANGING FOR THE FINANCING OF EXTENDED SERVICE WARRANTY CONTRACTS FOR VEHICLES (U.S. CLS. 100, 101 AND 102).

FIRST USE 12-13-2010; IN COMMERCE 12-13-2010.

LINDA ORNDORFF, EXAMINING ATTORNEY

**CLASS 36—(Continued).**

SN 85-199,698. GENERAL MILLS, INC., MINNEAPOLIS, MN. FILED 12-16-2010.

**EBOXTOPS**

THE MARK CONSISTS OF STANDARD CHARACTERS WITHOUT CLAIM TO ANY PARTICULAR FONT, STYLE, SIZE, OR COLOR.

OWNER OF U.S. REG. NOS. 3,378,189 AND 3,597,701. FOR CHARITABLE SERVICES, NAMELY, GRANTING FUNDS TO SCHOOLS (U.S. CLS. 100, 101 AND 102). FIRST USE 11-3-2010; IN COMMERCE 11-3-2010. PATRICIA EVANKO, EXAMINING ATTORNEY

SN 85-200,268. MAZDA MOTOR OF AMERICA, INC., IRVINE, CA. FILED 12-17-2010.

**MAZDA TOTAL ADVANTAGE**

THE MARK CONSISTS OF STANDARD CHARACTERS WITHOUT CLAIM TO ANY PARTICULAR FONT, STYLE, SIZE, OR COLOR.

OWNER OF U.S. REG. NOS. 2,987,176, 3,427,945 AND OTHERS. FOR EXTENDED WARRANTY SERVICES, NAMELY, SERVICE CONTRACTS; INSURANCE ADMINISTRATION IN THE FIELD OF VEHICLE MAINTENANCE INSURANCE (U.S. CLS. 100, 101 AND 102). SHAUNIA CARLYLE, EXAMINING ATTORNEY

SN 85-203,845. MEDAMERICA INSURANCE COMPANY, ROCHESTER, NY. FILED 12-22-2010.

**TRANSITIONS**

THE MARK CONSISTS OF STANDARD CHARACTERS WITHOUT CLAIM TO ANY PARTICULAR FONT, STYLE, SIZE, OR COLOR.

FOR INSURANCE UNDERWRITING SERVICES IN THE FIELD OF SHORT TERM CARE INSURANCE (U.S. CLS. 100, 101 AND 102). SUSAN STIGLITZ, EXAMINING ATTORNEY

**CLASS 36—(Continued).**

SN 85-225,447. EASTERN CONNECTICUT HEALTH NETWORK, INC., MANCHESTER, CT. FILED 1-25-2011.

**NEIGHBORS & FRIENDS**

THE MARK CONSISTS OF STANDARD CHARACTERS WITHOUT CLAIM TO ANY PARTICULAR FONT, STYLE, SIZE, OR COLOR.

FOR CHARITABLE FUNDRAISING, NAMELY, RAISING FUNDS FOR THE COST OF PROVIDING SERVICES AND RESEARCH IN HEALTHCARE (U.S. CLS. 100, 101 AND 102). FIRST USE 3-31-2001; IN COMMERCE 3-31-2001. KATHERINE STOIDES, EXAMINING ATTORNEY

**CLASS 37—CONSTRUCTION AND REPAIR**

SN 76-704,843. VICKORY, BRENDA GAIL, MYRTLE BEACH, SC. FILED 10-12-2010.



THE NAME "JERRY DAN" IDENTIFIES A LIVING INDIVIDUAL WHOSE CONSENT IS OF RECORD.

THE MARK CONSISTS OF THE WORDING "JERRY DAN" REPRESENTED IN STYLIZED FONT WITH A DESIGN OF THE HEAD OF A MAN WITH A MUSTACHE AND WEARING A BOWLER HAT WITH A PIECE OF GUTTER GOING THROUGH IT.

FOR INSTALLATION OF SEAMLESS GUTTERS FOR RESIDENTIAL AND COMMERCIAL PURPOSES (U.S. CLS. 100, 103 AND 106).

FIRST USE 10-10-1984; IN COMMERCE 7-18-1994. WARREN L. OLANDRIA, EXAMINING ATTORNEY

**CLASS 37—(Continued).**

SN 76-704,873. HILLWOOD DEVELOPMENT COMPANY, LLC, DALLAS, TX. FILED 10-13-2010.



OWNER OF U.S. REG. NOS. 1,563,802, 2,723,273 AND OTHERS.

NO CLAIM IS MADE TO THE EXCLUSIVE RIGHT TO USE "FLORIDA", APART FROM THE MARK AS SHOWN.

THE MARK CONSISTS OF THE STYLIZED WORDINGS "ALLIANCE FLORIDA", WITH A FIVE-POINT STAR DESIGN APPEARING BETWEEN THEM.

FOR CONSTRUCTION MANAGEMENT AND DEVELOPMENT OF REAL ESTATE, NAMELY, PLANNING AND LAYING OUT MIXED-USE REAL ESTATE DEVELOPMENTS (U.S. CLS. 100, 103 AND 106).

FIRST USE 9-23-2010; IN COMMERCE 9-23-2010.  
DAWN HAN, EXAMINING ATTORNEY

SN 77-793,501. DUST QUEEN INC., EDMONTON, ALBERTA, CANADA, FILED 7-30-2009.



PRIORITY CLAIMED UNDER SEC. 44(D) ON CANADA APPLICATION NO. 1,446,507, FILED 7-29-2009, REG. NO. TMA771,175, DATED 7-5-2010, EXPIRES 7-5-2025.

NO CLAIM IS MADE TO THE EXCLUSIVE RIGHT TO USE "MAID SERVICE", APART FROM THE MARK AS SHOWN.

THE MARK CONSISTS OF A CROWN DESIGN AND THE WORDS "DUST QUEEN MAID SERVICE".

FOR CLEANING OF RESIDENTIAL HOMES (U.S. CLS. 100, 103 AND 106).

MARK PILARO, EXAMINING ATTORNEY

SN 77-921,799. ISKIN INC., TORONTO, ONTARIO, CANADA, FILED 1-27-2010.

## ISKIN TATTOO

THE MARK CONSISTS OF STANDARD CHARACTERS WITHOUT CLAIM TO ANY PARTICULAR FONT, STYLE, SIZE, OR COLOR.

OWNER OF U.S. REG. NO. 2,970,692.

NO CLAIM IS MADE TO THE EXCLUSIVE RIGHT TO USE "TATTOO", APART FROM THE MARK AS SHOWN.

FOR APPLICATION OF DECORATIVE TREATMENTS TO CASES AND COVERS FOR COMPUTERS AND HAND HELD PORTABLE ENTERTAINMENT AND MESSAGING DEVICES, EXCLUDING COMPUTER KEYBOARD COVERS, SAID SERVICES TO BE ORDERED VIA WEBSITE (U.S. CLS. 100, 103 AND 106).

TRACY WHITTAKER-BROWN, EXAMINING ATTORNEY

**CLASS 37—(Continued).**

SN 77-937,602. AEVENIA, INC., MOORHEAD, MN. FILED 2-17-2010.

## AEVENIA. THE WAY ENERGY MOVES

THE MARK CONSISTS OF STANDARD CHARACTERS WITHOUT CLAIM TO ANY PARTICULAR FONT, STYLE, SIZE, OR COLOR.

OWNER OF U.S. REG. NOS. 3,736,543 AND 3,739,307.

FOR CONSTRUCTION OF ENERGY TRANSMISSION AND DISTRIBUTION LINES, SUBSTATIONS, WIND FARMS, TELECOMMUNICATIONS AND FIBER OPTICS SYSTEMS, AND COMMERCIAL/INDUSTRIAL ELECTRICAL PROJECTS (U.S. CLS. 100, 103 AND 106).

FIRST USE 5-4-2009; IN COMMERCE 5-4-2009.  
SUE LAWRENCE, EXAMINING ATTORNEY

SN 77-962,210. ADVANCED FOUNDATION REPAIR, L.P., DALLAS, TX. FILED 3-18-2010.

### ADVANCED FOUNDATION REPAIR

THE MARK CONSISTS OF STANDARD CHARACTERS WITHOUT CLAIM TO ANY PARTICULAR FONT, STYLE, SIZE, OR COLOR.

NO CLAIM IS MADE TO THE EXCLUSIVE RIGHT TO USE "FOUNDATION REPAIR", APART FROM THE MARK AS SHOWN.

SEC. 2(F).

FOR FOUNDATION REPAIR SERVICES; FOUNDATION MAINTENANCE SERVICES; PROVIDING A WEBSITE THAT FEATURES INFORMATION ABOUT FOUNDATION MAINTENANCE AND FOUNDATION REPAIR SERVICES (U.S. CLS. 100, 103 AND 106).

FIRST USE 1-1-1999; IN COMMERCE 1-1-1999.  
TINA L. SNAPP, EXAMINING ATTORNEY

SN 77-969,793. MASCO HOME SERVICES, INC., DAYTONA BEACH, FL. FILED 3-26-2010.

## HOMESTAR

THE MARK CONSISTS OF STANDARD CHARACTERS WITHOUT CLAIM TO ANY PARTICULAR FONT, STYLE, SIZE, OR COLOR.

FOR BUILDING CONSTRUCTION AND REMODELING SERVICES (U.S. CLS. 100, 103 AND 106).

MORGAN WYNNE, EXAMINING ATTORNEY

**CLASS 37—(Continued).**

SN 85-018,039. RIGGS, STEPHEN ERIK, TA WIREMONKEYS, NORTH CHARLESTON, SC. FILED 4-20-2010.



NO CLAIM IS MADE TO THE EXCLUSIVE RIGHT TO USE "HOME ENTERTAINMENT SOLUTIONS", APART FROM THE MARK AS SHOWN.

THE COLOR(S) BLACK, GREEN, AND WHITE IS/ARE CLAIMED AS A FEATURE OF THE MARK.

THE MARK CONSISTS OF THE DESIGN OF A BLACK MONKEY WITH A CURLED TAIL APPEARING NEXT TO THE WORDS "WIRE MONKEYS HOME ENTERTAINMENT SOLUTIONS" APPEARING IN BLACK WITH A BLACK SHADED CIRCLE APPEARING WITHIN THE "O" IN "MONKEYS" AND WITH BLACK HORIZONTAL LINES APPEARING ABOVE AND BELOW THE TERM "MONKEYS" AND BLACK SOUND WAVES APPEARING ABOVE THE "I" IN "WIRE", ALL AGAINST A GREEN BACKGROUND AND SURROUNDED BY A WHITE AND BLACK BORDER. THE GREY IN THE MARK APPEARS FOR BACKGROUND PURPOSES AND IS NOT CLAIMED AS A FEATURE OF THE MARK.

FOR INSTALLATION OF CUSTOM, HIGH END HOME THEATERS AND RELATED STRUCTURED WIRING, WHOLE HOUSE MUSIC DISTRIBUTION SYSTEMS, MULTI MEDIA SERVER SYSTEMS, CENTRAL VACUUM SYSTEMS, AND LIGHTING CONTROL SYSTEMS (U.S. CLS. 100, 103 AND 106).

FIRST USE 1-1-2010; IN COMMERCE 1-1-2010.  
CHRISTINE MARTIN, EXAMINING ATTORNEY

**CLASS 37—(Continued).**

SN 85-037,513. THE MACALLAN GROUP, LLC, ATLANTA, GA. FILED 5-13-2010.



NO CLAIM IS MADE TO THE EXCLUSIVE RIGHT TO USE "GROUP", APART FROM THE MARK AS SHOWN.

THE MARK CONSISTS OF A STYLIZED "M" WITH THE WORDING "THE MACALLAN GROUP" BELOW.

FOR RESIDENTIAL AND COMMERCIAL BUILDING CONSTRUCTION AND GENERAL CONSTRUCTION CONTRACTING, CONSTRUCTION MANAGEMENT, RENOVATION OF RESIDENTIAL AND COMMERCIAL PROPERTIES, REAL ESTATE DEVELOPMENT, CONSULTING ON REAL ESTATE RELATED MATTERS, IN THE NATURE OF REAL ESTATE DEVELOPMENT (U.S. CLS. 100, 103 AND 106).

FIRST USE 6-30-2005; IN COMMERCE 11-30-2008.  
CHRISTINA SOBRAL, EXAMINING ATTORNEY

SN 85-037,477. THE MACALLAN GROUP, LLC, ATLANTA, GA. FILED 5-13-2010.

**THE MACALLAN GROUP**

THE MARK CONSISTS OF STANDARD CHARACTERS WITHOUT CLAIM TO ANY PARTICULAR FONT, STYLE, SIZE, OR COLOR.

NO CLAIM IS MADE TO THE EXCLUSIVE RIGHT TO USE "GROUP", APART FROM THE MARK AS SHOWN.

FOR RESIDENTIAL AND COMMERCIAL BUILDING CONSTRUCTION AND GENERAL CONSTRUCTION CONTRACTING, CONSTRUCTION MANAGEMENT, RENOVATION OF RESIDENTIAL AND COMMERCIAL PROPERTIES, REAL ESTATE DEVELOPMENT, CONSULTING ON REAL ESTATE RELATED MATTERS, IN THE NATURE OF REAL ESTATE DEVELOPMENT (U.S. CLS. 100, 103 AND 106).

FIRST USE 5-31-2002; IN COMMERCE 11-30-2008.  
CHRISTINA SOBRAL, EXAMINING ATTORNEY

SN 85-048,611. ASSOCIATED THEATRICAL CONTRACTORS, INC., SPRINGFIELD, MO. FILED 5-26-2010.



THE MARK CONSISTS OF STYLIZED MAN DEPICTED IN CARICATURE FORM.

FOR CUSTOM CONSTRUCTION OF THEATRICAL SETS, STAGES AND PAINTED SCENERY, AND REPAIR OF THEATRICAL SETS, STAGES, PAINTED SCENERY PROPS, DRAPERY, THEATRICAL LIGHTING SYSTEMS AND SOUND AND CONTROL SYSTEMS (U.S. CLS. 100, 103 AND 106).

FIRST USE 1-31-1986; IN COMMERCE 1-31-1986.  
MARK PILARO, EXAMINING ATTORNEY

**CLASS 37—(Continued).**

SN 85-083,075. AIR ESSENTIALS, MADISON, AL. FILED 7-13-2010.



NO CLAIM IS MADE TO THE EXCLUSIVE RIGHT TO USE "AIR", APART FROM THE MARK AS SHOWN.

THE MARK CONSISTS OF THREE STYLIZED, WAVY STREAKS LOCATED TO THE LEFT OF THE WORD "AIR" AND ABOVE THE WORD "ESSENTIAL", WITH EACH STREAK TAPERING FROM A THICKER TOP TO A THINNER BOTTOM.

FOR AIR DUCT CLEANING SERVICES (U.S. CLS. 100, 103 AND 106).

FIRST USE 11-8-2001; IN COMMERCE 12-3-2001.  
JULIE WATSON, EXAMINING ATTORNEY

SN 85-083,117. AIR ESSENTIALS, MADISON, AL. FILED 7-13-2010.

---

## AIR ESSENTIALS

THE MARK CONSISTS OF STANDARD CHARACTERS WITHOUT CLAIM TO ANY PARTICULAR FONT, STYLE, SIZE, OR COLOR.

NO CLAIM IS MADE TO THE EXCLUSIVE RIGHT TO USE "AIR", APART FROM THE MARK AS SHOWN.

FOR AIR DUCT CLEANING SERVICES (U.S. CLS. 100, 103 AND 106).

FIRST USE 4-1-2001; IN COMMERCE 5-1-2001.  
JULIE WATSON, EXAMINING ATTORNEY

SN 85-121,033. JIM MELLON GENERAL CONTRACTING, INC., DBA MELLON CERTIFIED RESTORATION, YEADON, PA. FILED 9-1-2010.



NO CLAIM IS MADE TO THE EXCLUSIVE RIGHT TO USE "FIRE DAMAGE EXPERTS", APART FROM THE MARK AS SHOWN.

THE MARK CONSISTS OF A STYLIZED DEPICTION OF THE WORDS "FIREDEX FIRE DAMAGE EXPERTS" WITH A DEPICTION OF A FLAME APPEARING IN LIEU OF THE DOT OVER THE FIRST LETTER "I".

FOR CONSTRUCTION AND REPAIR SERVICES SPECIALIZING IN RESTORATION OF PROPERTY DAMAGED BY FIRE, SMOKE, WATER OR OTHER NATURAL PERILS (U.S. CLS. 100, 103 AND 106).

FIRST USE 5-5-1980; IN COMMERCE 5-12-1980.  
LINDA E. BLOHM, EXAMINING ATTORNEY

**CLASS 37—(Continued).**

SN 85-134,917. RED DIAMOND ROOFING, INC., DENVER, CO. FILED 9-21-2010.

## RED DIAMOND ROOFING

THE MARK CONSISTS OF STANDARD CHARACTERS WITHOUT CLAIM TO ANY PARTICULAR FONT, STYLE, SIZE, OR COLOR.

NO CLAIM IS MADE TO THE EXCLUSIVE RIGHT TO USE "ROOFING", APART FROM THE MARK AS SHOWN.

FOR HOUSE PAINTING; INSTALLATION OF WINDOWS, GUTTERS AND ATTIC INSULATION; INSTALLING SIDING; ROOFING SERVICES (U.S. CLS. 100, 103 AND 106).

FIRST USE 7-29-2010; IN COMMERCE 7-29-2010.  
AISHA CLARKE, EXAMINING ATTORNEY

SN 85-151,805. HUMPHRIES, CHRISTOPHER, MYRTLE BEACH, SC. FILED 10-13-2010.



NO CLAIM IS MADE TO THE EXCLUSIVE RIGHT TO USE "BIN" AND THE REPRESENTATION OF THE UNIVERSAL RECYCLING SYMBOL, APART FROM THE MARK AS SHOWN.

THE MARK CONSISTS OF A PELICAN BIRD STANDING ON ONE FOOT WITH A BIG TOOTH GRIN WITH A SHINY SPOT ON THE TEETH AND WINKING, APPEARING AT THE END OF THE STYLIZED WORDING "PELICLEAN". THE PELICAN HAS A NAME TAG IN THE SHAPE OF A ROLLING GARBAGE CAN WITH THE NAME "BIN" ON AN OXFORD SHIRT. ON THE LEFT OF THE WORDING "PELICLEAN" IS THE RECYCLE SYMBOL WITH THE WATER DROP IN THE MIDDLE.

FOR CLEANING OF GARBAGE BINS (U.S. CLS. 100, 103 AND 106).

FIRST USE 10-5-2007; IN COMMERCE 9-16-2010.  
JENNY PARK, EXAMINING ATTORNEY

**CLASS 37—(Continued).**

SN 85-156,191. UIP, LLC, NW, DC. FILED 10-19-2010.

**UIP Urban Investment  
Partners**

THE MARK CONSISTS OF STANDARD CHARACTERS WITHOUT CLAIM TO ANY PARTICULAR FONT, STYLE, SIZE, OR COLOR.

NO CLAIM IS MADE TO THE EXCLUSIVE RIGHT TO USE "URBAN INVESTMENT PARTNERS", APART FROM THE MARK AS SHOWN.

FOR REAL ESTATE DEVELOPMENT (U.S. CLS. 100, 103 AND 106).

FIRST USE 9-30-2004; IN COMMERCE 9-30-2004.  
MARGERY A. TIERNEY, EXAMINING ATTORNEY

**CLASS 37—(Continued).**

SN 85-156,702. CHIMNEY CRICKET FRANCHISING, LLC, LIVONIA, MI. FILED 10-20-2010.



OWNER OF U.S. REG. NOS. 3,627,017 AND 3,627,018.  
THE MARK CONSISTS OF A CRICKET WEARING TUXEDO COAT AND TOP HAT AND HAVING CHIMNEY CLEANING SUPPLIES POSITIONED TO THE RIGHT OF THE WORDING "CHIMNEY CRICKET".

FOR CHIMNEY SWEEPING (U.S. CLS. 100, 103 AND 106).

FIRST USE 5-31-2009; IN COMMERCE 5-31-2009.  
JAMES LOVELACE, EXAMINING ATTORNEY

SN 85-156,525. AUTO CENTRIC INC, GRAND RAPIDS, MI. FILED 10-19-2010.



NO CLAIM IS MADE TO THE EXCLUSIVE RIGHT TO USE "AUTO", APART FROM THE MARK AS SHOWN.

THE MARK CONSISTS OF THE WORDING "AUTO CENTRIC" IN STYLIZED FONT APPEARING TO THE RIGHT OF A ROUND CIRCLE WITH A CAR ON HOIST AND A WRENCH APPEARING BOTH INSIDE THE CIRCLE. AT THE OTHER END IS AN ARROW WITH 3 OUTLINED SLASH MARKS.

FOR AUTOMOTIVE MAINTENANCE AND REPAIR (U.S. CLS. 100, 103 AND 106).

FIRST USE 8-1-2010; IN COMMERCE 8-1-2010.  
EMILY CHUO, EXAMINING ATTORNEY

SN 85-157,214. MIRACLE HOT TANKLESS WATER HEATERS LLC, LIGHT HOUSE POINT, FL. FILED 10-20-2010.



SN 85-156,608. APEX MOUNTAIN HOMES, INC., FRISCO, CO. FILED 10-20-2010.



NO CLAIM IS MADE TO THE EXCLUSIVE RIGHT TO USE "GREEN BUILT", APART FROM THE MARK AS SHOWN.

THE MARK CONSISTS OF THE LETTER "G" IN A SQUARE, THE WORDING "GREEN BUILT" IN A RECTANGLE TO THE RIGHT OF THE FOREGOING, AND THE WORDING "SUSTAINABLE FOR ALL RESIDENTS" IN A RECTANGLE LOCATED BELOW ALL OF THE FOREGOING.

FOR CUSTOM CONSTRUCTION OF HOMES (U.S. CLS. 100, 103 AND 106).

FIRST USE 8-0-2009; IN COMMERCE 8-0-2009.  
KAREN K. BUSH, EXAMINING ATTORNEY

NO CLAIM IS MADE TO THE EXCLUSIVE RIGHT TO USE "HOT TANKLESS WATER HEATERS", APART FROM THE MARK AS SHOWN.

THE COLOR(S) DEEP BLUE, AND BURNT ORANGE IS/ ARE CLAIMED AS A FEATURE OF THE MARK.

THE MARK CONSISTS OF BLUE: "MIRACLE TANKLESS WATER HEATERS" ORANGE: "HOT" THE "I" WILL CONSIST OF BLUE WATER DROP WITH ORANGE FLAME WITHIN THE WORD "MIRACLE".

FOR INSTALLATION AND REPLACEMENT SERVICE FOR WATER HEATERS (U.S. CLS. 100, 103 AND 106).

FLORENTINA BLANDU, EXAMINING ATTORNEY

**CLASS 37—(Continued).**

SN 85-157,311. ORKIN EXPANSION, INC., WILMINGTON, DE. FILED 10-20-2010.



NO CLAIM IS MADE TO THE EXCLUSIVE RIGHT TO USE "PROTECTION" AND "HEALTHCARE", APART FROM THE MARK AS SHOWN.

THE COLOR(S) GOLD AND GRAY IS/ARE CLAIMED AS A FEATURE OF THE MARK.

THE MARK CONSISTS OF A GOLD RECTANGLE WITH AN EMBOSSED TYPE FRAME, THE WORDS "GOLD MEDAL PROTECTION" ARE EMBOSSED INSIDE THE RECTANGLE, CENTERED BELOW THE FRAME IS A GRAY BANNER WITH THE WORD "HEALTHCARE" IN GRAY LETTERS.

FOR PEST CONTROL SERVICES (U.S. CLS. 100, 103 AND 106).

MARIA-VICTORIA SUAREZ, EXAMINING ATTORNEY

SN 85-157,606. COMO, FRANK, LITTLE SILVER, NJ. FILED 10-20-2010.

## BedBug Chaser

THE MARK CONSISTS OF STANDARD CHARACTERS WITHOUT CLAIM TO ANY PARTICULAR FONT, STYLE, SIZE, OR COLOR.

NO CLAIM IS MADE TO THE EXCLUSIVE RIGHT TO USE "BEDBUG", APART FROM THE MARK AS SHOWN.

FOR DISINFECTING; PEST CONTROL; PEST CONTROL AND EXTERMINATION OTHER THAN FOR AGRICULTURAL PURPOSES; TERMITE AND PEST CONTROL (U.S. CLS. 100, 103 AND 106).

FIRST USE 6-1-2010; IN COMMERCE 6-1-2010.

GINA FINK, EXAMINING ATTORNEY

**CLASS 37—(Continued).**

SN 85-158,023. DEPARTMENT OF THE NAVY, ARLINGTON, VA. FILED 10-21-2010.

## MAINTAINEPEDIA

THE MARK CONSISTS OF STANDARD CHARACTERS WITHOUT CLAIM TO ANY PARTICULAR FONT, STYLE, SIZE, OR COLOR.

FOR ONLINE INTERACTIVE DATABASE IN THE FIELD OF REPAIR, UPKEEP, AND MODERNIZATION OF NAVAL VESSELS AND EQUIPMENT RELATED TO NAVAL VESSELS (U.S. CLS. 100, 103 AND 106).

ANDREW LEASER, EXAMINING ATTORNEY

SN 85-158,069. ELITE RESTORATIONS, INC., HOLLYWOOD, FL. FILED 10-21-2010.

## ELITE RESTORATIONS

THE MARK CONSISTS OF STANDARD CHARACTERS WITHOUT CLAIM TO ANY PARTICULAR FONT, STYLE, SIZE, OR COLOR.

NO CLAIM IS MADE TO THE EXCLUSIVE RIGHT TO USE "RESTORATIONS", APART FROM THE MARK AS SHOWN.

FOR GENERAL CONTRACTOR SERVICES, NAMELY, FIRE, WATER, MOLD, AND STORM RESTORATIONS, AS WELL AS, INSURANCE REPAIR WORK ON RESIDENTIAL AND COMMERCIAL BUILDINGS (U.S. CLS. 100, 103 AND 106).

FIRST USE 8-30-1984; IN COMMERCE 8-30-1984.

LINDA E. BLOHM, EXAMINING ATTORNEY

SN 85-158,131. NATIONAL GUARDIAN ENTERPRISES, INC., WOODSIDE, CA. FILED 10-21-2010.

## NATIONAL GUARDIAN ENTERPRISES

THE MARK CONSISTS OF STANDARD CHARACTERS WITHOUT CLAIM TO ANY PARTICULAR FONT, STYLE, SIZE, OR COLOR.

NO CLAIM IS MADE TO THE EXCLUSIVE RIGHT TO USE "NATIONAL" OR "ENTERPRISES", APART FROM THE MARK AS SHOWN.

FOR KITCHEN EXHAUST CLEANING SERVICES (U.S. CLS. 100, 103 AND 106).

FIRST USE 6-17-1996; IN COMMERCE 6-17-1996.

KIMBERLY FRYE, EXAMINING ATTORNEY

**CLASS 37—(Continued).**

SN 85-158,168. ARCTIC COOL, INC., ALTAMONTE SPRINGS, FL. FILED 10-21-2010.

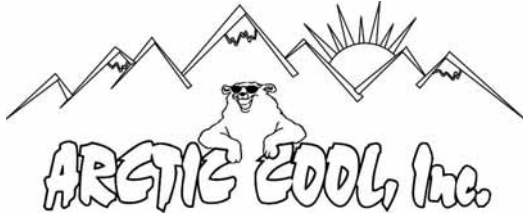

NO CLAIM IS MADE TO THE EXCLUSIVE RIGHT TO USE "INC.", APART FROM THE MARK AS SHOWN.

THE MARK CONSISTS OF A BEAR WITH SUNGLASSES BETWEEN THE WORDS "ARCTIC" AND "COOL, INC." WITH A MOUNTAIN RANGE BEHIND AND THE SUN POSITIONED BETWEEN TWO OF THE PEAKS AND SNOW ON THREE OF THE MOUNTAIN PEAKS.

FOR AIR CONDITIONING CONTRACTOR SERVICES; INSTALLATION AND REPAIR OF AIR CONDITIONING APPARATUS; INSTALLATION AND REPAIR OF HEATING, VENTILATING AND AIR CONDITIONING EQUIPMENT; INSTALLATION AND REPLACEMENT SERVICE FOR HEATING, VENTILATING AND AIR CONDITIONING SYSTEMS (U.S. CLS. 100, 103 AND 106).

FIRST USE 1-1-2010; IN COMMERCE 1-1-2010.  
JANICE L. MCMORROW, EXAMINING ATTORNEY

**CLASS 37—(Continued).**

SN 85-158,233. ORKIN EXPANSION, INC., WILMINGTON, DE. FILED 10-21-2010.



**DOUBLE DIAMOND**

OWNER OF U.S. REG. NOS. 568,404, 3,842,314 AND OTHERS.

THE COLOR(S) RED, WHITE AND BLACK IS/ARE CLAIMED AS A FEATURE OF THE MARK.

THE MARK CONSISTS OF RED DIAMOND WITH THE WORD "ORKIN" IN THE CENTER IN WHITE LETTERS AND THE WORDS "DOUBLE DIAMOND" CENTERED IN BLACK LETTERS UNDER THE DIAMOND.

FOR PEST CONTROL SERVICES (U.S. CLS. 100, 103 AND 106).  
MARIA-VICTORIA SUAREZ, EXAMINING ATTORNEY

SN 85-158,195. NATIONAL GUARDIAN ENTERPRISES, INC., WOODSIDE, CA. FILED 10-21-2010.



NO CLAIM IS MADE TO THE EXCLUSIVE RIGHT TO USE "NATIONAL" OR "ENTERPRISES", APART FROM THE MARK AS SHOWN.

THE COLOR(S) BLUE, YELLOW-GOLD, WHITE, GRAY IS/ARE CLAIMED AS A FEATURE OF THE MARK.

THE MARK CONSISTS OF THE TEXT "NATIONAL" IN WHITE INSIDE A BLUE BANNER, BELOW WHICH APPEARS THE TEXT "GUARDIAN" IN GRAY, AND BELOW THE FOREGOING TEXT APPEARS THE TEXT "ENTERPRISES" IN BLUE. ABOVE THESE THREE LINES OF TEXT APPEARS AN INCOMPLETE CIRCLE IN BLUE, WITH A YELLOW-GOLD CROSSBAR GOING THROUGH THE OPEN SPACE IN THE CIRCLE TO CREATE A STYLIZED "G".

FOR KITCHEN EXHAUST CLEANING SERVICES (U.S. CLS. 100, 103 AND 106).  
FIRST USE 8-1-2010; IN COMMERCE 8-1-2010.  
KIMBERLY FRYE, EXAMINING ATTORNEY

SN 85-174,668. CASHIDO CORPORATION, HSINCHU COUNTY 303, TAIWAN, FILED 11-11-2010.



THE MARK CONSISTS OF A BALL LIKE CONTOUR OVERLYING A LOWER PORTION OF A LEAF LIKE CONTOUR, ALL ABOVE THE STYLIZED WORD "CASHIDO".

FOR CONSTRUCTION SUPERVISION; KITCHEN EQUIPMENT INSTALLATION; MACHINERY INSTALLATION; MACHINERY MAINTENANCE AND REPAIR; PLUMBING; PROVIDING INFORMATION IN THE FIELD OF HOME RENOVATIONS AND REPAIRS; CLEANING OF CLOTHING; BUILDING CONSTRUCTION; BURGLAR ALARM INSTALLATION AND REPAIR; BUILDING CONSTRUCTION INFORMATION; ELECTRIC APPLIANCE INSTALLATION AND REPAIR (U.S. CLS. 100, 103 AND 106).

FLORENTINA BLANDU, EXAMINING ATTORNEY



**CLASS 37—(Continued).**

SN 85-175,446. WHALING ENTERPRISES, INC., DBA KOOL TOUCH, DUNCANVILLE, TX. FILED 11-12-2010.



THE COLOR(S) BLACK, BLUE AND WHITE IS/ARE CLAIMED AS A FEATURE OF THE MARK.

THE MARK CONSISTS OF THE WORDS KOOL TOUCH IN BLACK STYLIZED FONT. TO THE LEFT IS A WHITE CLOUD OUTLINED IN BLACK IN FRONT OF A SOLID BLUE SQUARE. BELOW THE DESCRIBED DRAWING AND WORDS IS A SOLID BLUE HORIZONTAL LINE.

FOR RESIDENTIAL AND COMMERCIAL INSTALLATION, MAINTENANCE, AND REPAIR OF REFRIGERATION, HEATING, AIR CONDITIONING, AND VENTILATION EQUIPMENT (U.S. CLS. 100, 103 AND 106).

FIRST USE 9-0-1993; IN COMMERCE 9-0-1993.  
KAREN K. BUSH, EXAMINING ATTORNEY

SN 85-175,527. MYERS SERVICES, INC., BEDFORD, TX. FILED 11-12-2010.

## Fire & Ice

THE MARK CONSISTS OF STANDARD CHARACTERS WITHOUT CLAIM TO ANY PARTICULAR FONT, STYLE, SIZE, OR COLOR.

FOR PEST CONTROL (U.S. CLS. 100, 103 AND 106).  
SUNG IN, EXAMINING ATTORNEY

SN 85-175,539. WEIHONG CAI, FLUSHING, NY. FILED 11-12-2010.

## BROADTRADE

THE MARK CONSISTS OF STANDARD CHARACTERS WITHOUT CLAIM TO ANY PARTICULAR FONT, STYLE, SIZE, OR COLOR.

FOR BUILDING CAULKING SERVICES; BUILDING CONSTRUCTION; BUILDING CONSTRUCTION AND REPAIR; BUILDING CONSTRUCTION INFORMATION; BUILDING CONSTRUCTION OBSERVATION, NAMELY, STATIC INSPECTION, FUNCTIONAL VERIFICATION INSPECTION, PERFORMANCE VERIFICATION INSPECTION; BUILDING CONSTRUCTION SERVICES; BUILDING CONSTRUCTION SUPERVISION; BUILDING CONSTRUCTION, REMODELING AND REPAIR; BUILDING DAMP-PROOFING; BUILDING DEMOLITION; BUILDING MAINTENANCE AND REPAIR; BUILDING REINFORCING; BUILDING RESTORATION; BUILDING SEALING AND CAULKING SERVICES; CLEANING OF BUILDING EXTERIOR SURFACES; CLEANING OF BUILDINGS; CLEANING OF EXTERNAL SURFACES OF BUILDINGS; CONSTRUCTION AND RENOVATION OF BUILDINGS; CONSTRUCTION AND REPAIR OF BUILDINGS; CONSTRUCTION OF

**CLASS 37—(Continued).**

BUILDINGS; CONSTRUCTION SERVICES, NAMELY, PLANNING, LAYING OUT AND CUSTOM CONSTRUCTION OF COMMERCIAL BUILDINGS; CONSULTING IN THE FIELD OF BUILDING CONSTRUCTION; CUSTOM CONSTRUCTION AND BUILDING RENOVATION; ELECTRIC APPLIANCE INSTALLATION AND REPAIR; ELECTRICAL CONTRACTING; ELECTRICAL CONTRACTOR SERVICES; ELECTRICAL REPAIRS, MAINTENANCE, AND INSTALLATION OF ELECTRICAL WIRING, OUTLETS, LIGHT FIXTURES, AND ELECTRICAL PANELS; GENERAL BUILDING CONTRACTOR SERVICES; GENERAL CONTRACTOR SERVICES, NAMELY, PLUMBING, HEATING AND AIR CONDITIONING, CARPENTRY, DRYWALL, PAINTING, ELECTRICAL, BUILDING AND FRAMING CONTRACTOR SERVICES; HANDYMAN SERVICE, NAMELY, BUILDING REPAIR AND MAINTENANCE; HEATING CONTRACTOR SERVICES; HEATING EQUIPMENT INSTALLATION AND REPAIR; HOUSE AND BUILDING DEMOLITION; HOUSE BUILDING AND REPAIR; HVAC CONTRACTOR SERVICES; INSTALLATION AND REPAIR OF HEATING, VENTILATING AND AIR CONDITIONING EQUIPMENT; INSTALLATION AND REPLACEMENT SERVICE FOR HEATING, VENTILATING AND AIR CONDITIONING SYSTEMS; INSTALLATION OF BUILDING INSULATION; INSTALLATION OF SECURITY SYSTEM; INSTALLATION OF SOLAR ENERGY SYSTEMS AND ALTERNATIVE ENERGY PRODUCTS FOR RESIDENTIAL AND COMMERCIAL USE; INSTALLATION SERVICES OF BUILDING SCAFFOLDS, WORKING AND BUILDING PLATFORMS; INSTALLATION, MAINTENANCE, AND REPAIR OF OUTDOOR AUTOMATED MIST SYSTEMS FOR INSECT AND PEST CONTROL; INSTALLATION, REPAIR AND MAINTENANCE OF HEATING EQUIPMENT; INTERFERENCE SUPPRESSION SERVICES FOR ELECTRICAL APPARATUS; LAND DEVELOPMENT SERVICES, NAMELY, PLANNING AND LAYING OUT OF COMMERCIAL BUILDINGS; MAINTENANCE AND REPAIR OF BUILDINGS; MAINTENANCE AND REPAIR OF HEATING INSTALLATIONS; MAINTENANCE OF ALARM SYSTEMS; PAINTING AND APPLYING COATINGS TO BUILDING INTERIORS AND BUILDING EXTERIORS; PLUMBING; PLUMBING AND GAS AND WATER INSTALLATION; PLUMBING CONTRACTOR SERVICES; PLUMBING SERVICES; RECAULKING SERVICES FOR BUILDINGS; RENOVATION AND RESTORATION OF BUILDINGS; REPAIR AND INSTALLATION SERVICES, NAMELY, THE INSTALLATION OF HEATING, COOLING AND ENVIRONMENTAL CONTROL SYSTEMS PRIMARILY USING SOLAR ENERGY, RENEWABLE ENERGY RESOURCES AND RAINWATER; REPAIR AND MAINTENANCE OF BUILDING SCAFFOLDS, WORKING AND BUILDING PLATFORMS; REPAIR AND MAINTENANCE OF BUILDINGS IN CASE OF DEMOLITION; REPAIR OF BUILDINGS; REPAIR OR MAINTENANCE OF ELECTRIC LIGHTING APPARATUS; REPAIR WORK ON BUILDINGS; RESIDENTIAL AND BUILDING CONSTRUCTION CONSULTING; RESIDENTIAL AND COMMERCIAL BUILDING CONSTRUCTION (U.S. CLS. 100, 103 AND 106).

FIRST USE 7-1-1998; IN COMMERCE 7-1-1998.  
SOPHIA S. KIM, EXAMINING ATTORNEY

SN 85-176,468. CONCRAFT, INC., DBA CONCRAFT, AUBURN HILLS, MI. FILED 11-15-2010.

## Concraft

THE MARK CONSISTS OF STANDARD CHARACTERS WITHOUT CLAIM TO ANY PARTICULAR FONT, STYLE, SIZE, OR COLOR.

FOR BUILDING RENOVATION SERVICES (U.S. CLS. 100, 103 AND 106).

JACLYN KIDWELL WALKER, EXAMINING ATTORNEY

**CLASS 37—(Continued).**

SN 85-177,090. EXCEL ROOFING, INCORPORATED, ENGLEWOOD, CO. FILED 11-15-2010.

**EXPECT THE VERY BEST**

THE MARK CONSISTS OF STANDARD CHARACTERS WITHOUT CLAIM TO ANY PARTICULAR FONT, STYLE, SIZE, OR COLOR.

FOR ROOFING INSTALLATION AND REPAIR SERVICES (U.S. CLS. 100, 103 AND 106).  
FIRST USE 9-24-2010; IN COMMERCE 11-6-2010.  
EDWARD NELSON, EXAMINING ATTORNEY

SN 85-178,842. HACH COMPANY, LOVELAND, CO. FILED 11-17-2010.

**HACH SERVICEPLUS**

THE MARK CONSISTS OF STANDARD CHARACTERS WITHOUT CLAIM TO ANY PARTICULAR FONT, STYLE, SIZE, OR COLOR.

FOR PROVIDING TECHNICAL SUPPORT, NAMELY, TECHNICAL ADVICE CONCERNING THE INSTALLATION, REPAIR AND MAINTENANCE OF MECHANICAL, ELECTRICAL OR ELECTRONIC APPARATUS, EQUIPMENT AND DEVICES USED FOR WATER MONITORING OR FLUID MONITORING; AND THE INSTALLATION, REPAIR AND MAINTENANCE OF ELECTRIC OR ELECTRONIC APPARATUS, EQUIPMENT AND DEVICES USED FOR WATER MONITORING OR FLUID MONITORING (U.S. CLS. 100, 103 AND 106).

FIRST USE 2-5-2010; IN COMMERCE 2-5-2010.  
NAAKWAMA ANKRAH, EXAMINING ATTORNEY

SN 85-178,943. CERTA PROPAINTERS, LTD., OAKS, PA. FILED 11-17-2010.

**BRISTLES**

THE MARK CONSISTS OF STANDARD CHARACTERS WITHOUT CLAIM TO ANY PARTICULAR FONT, STYLE, SIZE, OR COLOR.

OWNER OF U.S. REG. NO. 3,866,955.  
FOR PAINTING SERVICES, NAMELY, PAINTING RESIDENTIAL AND COMMERCIAL BUILDINGS (U.S. CLS. 100, 103 AND 106).  
FIRST USE 3-5-2010; IN COMMERCE 3-5-2010.  
SANJEEV VOHRA, EXAMINING ATTORNEY

**CLASS 37—(Continued).**

SN 85-179,041. JEFFREY VAN DIEPENS, RENO, NV. FILED 11-17-2010.

**Pest Management with  
Environ-Mentality**

THE MARK CONSISTS OF STANDARD CHARACTERS WITHOUT CLAIM TO ANY PARTICULAR FONT, STYLE, SIZE, OR COLOR.

NO CLAIM IS MADE TO THE EXCLUSIVE RIGHT TO USE "PEST MANAGEMENT", APART FROM THE MARK AS SHOWN.

FOR PEST CONTROL (U.S. CLS. 100, 103 AND 106).  
FIRST USE 7-29-2008; IN COMMERCE 7-29-2008.  
KHANH LE, EXAMINING ATTORNEY

SN 85-179,464. MENTOR GROUP, L.L.C., OREGON CITY, OR. FILED 11-17-2010.

**FIELDSHARP**

THE MARK CONSISTS OF STANDARD CHARACTERS WITHOUT CLAIM TO ANY PARTICULAR FONT, STYLE, SIZE, OR COLOR.

FOR KNIFE SHARPENING (U.S. CLS. 100, 103 AND 106).  
LESLEY LAMOTHE, EXAMINING ATTORNEY

SN 85-179,541. B H, INC., VERNAL, UT. FILED 11-17-2010.

**INDUSTRY EXCELLENCE  
POWERED BY VALUES**

THE MARK CONSISTS OF STANDARD CHARACTERS WITHOUT CLAIM TO ANY PARTICULAR FONT, STYLE, SIZE, OR COLOR.

FOR ELECTRICAL CONTRACTOR SERVICES; EXCAVATION SERVICES (U.S. CLS. 100, 103 AND 106).  
COLLEEN KEARNEY, EXAMINING ATTORNEY

**CLASS 37—(Continued).**

SN 85-181,320. BRIGHTHOUSE, LLC, ATLANTA, GA. FILED 11-19-2010.

**THINKING VILLAGE**

THE MARK CONSISTS OF STANDARD CHARACTERS WITHOUT CLAIM TO ANY PARTICULAR FONT, STYLE, SIZE, OR COLOR.

NO CLAIM IS MADE TO THE EXCLUSIVE RIGHT TO USE "VILLAGE", APART FROM THE MARK AS SHOWN.

FOR REAL ESTATE DEVELOPMENT SERVICES (U.S. CLS. 100, 103 AND 106).

LIEF MARTIN, EXAMINING ATTORNEY

**CLASS 38—(Continued).**

SN 77-966,065. KENTUCKY AUTHORITY FOR EDUCATIONAL TELEVISION, LEXINGTON, KY. FILED 3-23-2010.

**KENTUCKY CHANNEL**

THE MARK CONSISTS OF STANDARD CHARACTERS WITHOUT CLAIM TO ANY PARTICULAR FONT, STYLE, SIZE, OR COLOR.

NO CLAIM IS MADE TO THE EXCLUSIVE RIGHT TO USE "CHANNEL", APART FROM THE MARK AS SHOWN. SEC. 2(F).

FOR BROADCASTING OF EDUCATIONAL AND HISTORICAL TELEVISION PROGRAMS OF GENERAL INTEREST (U.S. CLS. 100, 101 AND 104).

FIRST USE 1-31-2008; IN COMMERCE 1-31-2008.

MARLENE BELL, EXAMINING ATTORNEY

SN 85-014,388. SAN PHONECISCO COMMUNICATIONS, INC, SAN FRANCISCO, CA. FILED 4-15-2010.

**IF YOU WANT TO AVOID THE HEALTH RISK OF USING A CELL PHONE... WE THE APP FOR THAT...****CLASS 38—COMMUNICATION**

SN 77-894,349. VALIDAS, LLC, MISSOURI CITY, TX. FILED 12-16-2009.

**fixmycellbill**

THE MARK CONSISTS OF STANDARD CHARACTERS WITHOUT CLAIM TO ANY PARTICULAR FONT, STYLE, SIZE, OR COLOR.

FOR TELECOMMUNICATIONS AND WIRELESS TELEPHONE COMMUNICATION SERVICES, NAMELY, TELECOMMUNICATION CONSULTATION TO THIRD-PARTY USERS WITH ACCESS TO TELECOMMUNICATION INFRASTRUCTURE FOR PERSONAL COMMUNICATIONS SERVICES CONCERNING BILLING AND TELEPHONE CALLING PLANS BASED ON DATA TRANSMISSION AND RECEPTION SERVICES AND EXCHANGE OF DATA STORED IN A DATABASE ACCESSIBLE VIA TELECOMMUNICATION MEANS (U.S. CLS. 100, 101 AND 104).

FIRST USE 8-1-2009; IN COMMERCE 8-1-2009.

BARBARA BROWN, EXAMINING ATTORNEY

THE MARK CONSISTS OF STANDARD CHARACTERS WITHOUT CLAIM TO ANY PARTICULAR FONT, STYLE, SIZE, OR COLOR.

FOR COMMUNICATIONS SERVICES, NAMELY, TELECOMMUNICATIONS SERVICES, NAMELY, WIRELESS TELEPHONY AND WIRELESS BROADBAND COMMUNICATIONS SERVICES FOR THE TRANSMISSION OF VOICE AND DATA (U.S. CLS. 100, 101 AND 104).

ERIN FALK, EXAMINING ATTORNEY

SN 85-014,398. GLIOMA SOCIETY, INC., BOSTON, MA. FILED 4-15-2010.



NO CLAIM IS MADE TO THE EXCLUSIVE RIGHT TO USE "GLIOMA SOCIETY", APART FROM THE MARK AS SHOWN.

THE COLOR(S) LIGHT BLUE, DARK BLUE, GRAY AND WHITE IS/ARE CLAIMED AS A FEATURE OF THE MARK. THE MARK CONSISTS OF THE WORDING "GLIOMA"

**CLASS 38—(Continued).**

AND "SOCIETY". THE WORD "GLIOMA" IS WRITTEN IN LIGHT AND DARK BLUE AND IS OUTLINED IN GRAY. THE "O" IN "GLIOMA" IS DEPICTED BY A PICTURE OF BRAIN THAT IS BLUE ON THE LEFT AND GRAY ON THE RIGHT WITH A WHITE CENTER AND WHITE VEINS. THE OUTER PORTION OF THE "O" IS MADE-UP OF 4 CURVED BAND/BARS THAT ALTERNATE BETWEEN GRAY AND LIGHT AND DARK BLUE. THE WORD "SOCIETY" IS WRITTEN IN GRAY COLOR BELOW THE WORD "GLIOMA".

FOR SCIENTIFIC SERVICE IN THE FORM OF PROVIDING A PLATFORM FOR MEDICAL AND SCIENTIFIC EXCHANGE, NAMELY, PROVIDING AN ON-LINE FORUM FOR MEDICAL AND SCIENTIFIC EXCHANGE REGARDING SCIENTIFIC AND LAYMEN INFORMATION ON GLIOMA BRAIN TUMORS (U.S. CLS. 100, 101 AND 104).

FIRST USE 7-1-2009; IN COMMERCE 8-8-2009.  
INGRID C. EULIN, EXAMINING ATTORNEY

**CLASS 38—(Continued).**

SN 85-025,515. PAY TEL COMMUNICATIONS, INC., GREENSBORO, NC. FILED 4-28-2010.



OWNER OF U.S. REG. NO. 1,568,832.

THE MARK CONSISTS OF A STYLIZED DEPICTION OF THE WORD "PAYTEL" WITH A DOT BETWEEN "PAY" AND "TEL" AND A DOT NEXT TO THE LETTER "L" AND 3 DIFFERENT SIZED CRESCENTS APPEARING TO THE UPPER-RIGHT OF THE DOT NEXT TO THE LETTER "L".

FOR TELECOMMUNICATION SERVICES, NAMELY, PROVIDING TELEPHONE SERVICES TO INMATES (U.S. CLS. 100, 101 AND 104).

FIRST USE 1-0-2005; IN COMMERCE 1-0-2005.  
NICHOLAS ALTREE, EXAMINING ATTORNEY

SN 85-020,628. WAVE2WAVE COMMUNICATIONS, INC., HACKENSACK, NJ. FILED 4-22-2010.

SN 85-025,518. PAY TEL COMMUNICATIONS, INC., GREENSBORO, NC. FILED 4-28-2010.

See, Hear, Now!



THE MARK CONSISTS OF STANDARD CHARACTERS WITHOUT CLAIM TO ANY PARTICULAR FONT, STYLE, SIZE, OR COLOR.

NO CLAIM IS MADE TO THE EXCLUSIVE RIGHT TO USE "SEE, HEAR", APART FROM THE MARK AS SHOWN.

FOR TELECOMMUNICATION SERVICES, NAMELY, TRANSMISSION OF VOICE, DATA, GRAPHICS, IMAGES, AUDIO AND VIDEO BY MEANS OF TELECOMMUNICATIONS NETWORKS, WIRELESS COMMUNICATION NETWORKS, AND THE INTERNET (U.S. CLS. 100, 101 AND 104).

FIRST USE 4-1-2010; IN COMMERCE 4-1-2010.  
BERYL GARDNER, EXAMINING ATTORNEY

THE MARK CONSISTS OF A STYLIZED DEPICTION OF THE WORDS "PAYTEL ADVANTAGE" WITH A DOT BETWEEN "PAY" AND "TEL" AND A DOT NEXT TO THE LETTER "L" AND 3 DIFFERENT SIZED CRESCENTS APPEARING TO THE UPPER-RIGHT OF THE DOT NEXT TO THE LETTER "L". THE WORD "PAYTEL" IS ABOVE THE WORD "ADVANTAGE".

FOR TELECOMMUNICATION SERVICES, NAMELY, PROVIDING TELEPHONE SERVICES TO INMATES (U.S. CLS. 100, 101 AND 104).

FIRST USE 4-22-2010; IN COMMERCE 4-22-2010.  
NICHOLAS ALTREE, EXAMINING ATTORNEY

**CLASS 38—(Continued).**

SN 85-088,124. AIRBIQUITY INC., SEATTLE, WA. FILED 7-19-2010.

**AIRBIQUITY CHOREO**

THE MARK CONSISTS OF STANDARD CHARACTERS WITHOUT CLAIM TO ANY PARTICULAR FONT, STYLE, SIZE, OR COLOR.

OWNER OF U.S. REG. NOS. 3,708,607, 3,714,751 AND OTHERS.

FOR TRANSMISSION AND DISTRIBUTION OF VOICE AND DATA SIGNALS TO AND FROM AUTOMOBILES; TRANSMISSION AND DISTRIBUTION OF DATA OR AUDIO VISUAL IMAGES VIA A GLOBAL COMPUTER NETWORK OR THE INTERNET (U.S. CLS. 100, 101 AND 104).

FIRST USE 6-30-2010; IN COMMERCE 6-30-2010.  
TEJBIR SINGH, EXAMINING ATTORNEY

SN 85-096,625. CIMA TELECOM INC., MIAMI, FL. FILED 7-30-2010.

**AURIS TECHNOLOGY**

THE MARK CONSISTS OF STANDARD CHARACTERS WITHOUT CLAIM TO ANY PARTICULAR FONT, STYLE, SIZE, OR COLOR.

NO CLAIM IS MADE TO THE EXCLUSIVE RIGHT TO USE "TECHNOLOGY", APART FROM THE MARK AS SHOWN.

FOR TELECOMMUNICATIONS SERVICES, NAMELY, PROVIDING CUSTOM AND BUNDLED NATIONAL AND INTERNATIONAL TELEPHONE CALLING PLAN SERVICES AND WIRELESS MOBILE TELEPHONE CALLING PLANS (U.S. CLS. 100, 101 AND 104).

FIRST USE 6-0-2001; IN COMMERCE 6-0-2001.  
STEVEN JACKSON, EXAMINING ATTORNEY

SN 85-096,671. CIMA TELECOM INC., MIAMI, FL. FILED 7-30-2010.

**AURIS PREPAID**

THE MARK CONSISTS OF STANDARD CHARACTERS WITHOUT CLAIM TO ANY PARTICULAR FONT, STYLE, SIZE, OR COLOR.

NO CLAIM IS MADE TO THE EXCLUSIVE RIGHT TO USE "PREPAID", APART FROM THE MARK AS SHOWN.

FOR TELECOMMUNICATIONS SERVICES, NAMELY, PROVIDING CUSTOM AND BUNDLED NATIONAL AND INTERNATIONAL TELEPHONE CALLING PLAN SERVICES AND WIRELESS MOBILE TELEPHONE CALLING PLANS (U.S. CLS. 100, 101 AND 104).

FIRST USE 10-0-2002; IN COMMERCE 10-0-2002.  
STEVEN JACKSON, EXAMINING ATTORNEY

**CLASS 38—(Continued).**

SN 85-108,685. CIMA TELECOM INC., MIAMI, FL. FILED 8-16-2010.

**AURIS**

THE MARK CONSISTS OF STANDARD CHARACTERS WITHOUT CLAIM TO ANY PARTICULAR FONT, STYLE, SIZE, OR COLOR.

FOR TELECOMMUNICATIONS SERVICES, NAMELY, PROVIDING CUSTOM AND BUNDLED NATIONAL AND INTERNATIONAL TELEPHONE CALLING PLAN SERVICES AND WIRELESS MOBILE TELEPHONE CALLING PLANS (U.S. CLS. 100, 101 AND 104).

FIRST USE 2-19-2002; IN COMMERCE 2-19-2002.  
STEVEN JACKSON, EXAMINING ATTORNEY

SN 85-110,378. CIMA TELECOM INC., MIAMI, FL. FILED 8-18-2010.

**AURIS WHOLESALE**

THE MARK CONSISTS OF STANDARD CHARACTERS WITHOUT CLAIM TO ANY PARTICULAR FONT, STYLE, SIZE, OR COLOR.

NO CLAIM IS MADE TO THE EXCLUSIVE RIGHT TO USE "WHOLESALE", APART FROM THE MARK AS SHOWN.

FOR TELECOMMUNICATIONS SERVICES, NAMELY, PROVIDING CUSTOM AND BUNDLED NATIONAL AND INTERNATIONAL TELEPHONE CALLING PLAN SERVICES AND WIRELESS MOBILE TELEPHONE CALLING PLANS (U.S. CLS. 100, 101 AND 104).

FIRST USE 1-0-2010; IN COMMERCE 1-0-2010.  
STEVEN JACKSON, EXAMINING ATTORNEY

SN 85-118,414. DATRAN MEDIA LLC, NEW YORK, NY. FILED 8-30-2010.

**CloudSMTP** 

NO CLAIM IS MADE TO THE EXCLUSIVE RIGHT TO USE "CLOUDSMTP", APART FROM THE MARK AS SHOWN.

THE COLOR(S) BLUE, WHITE AND BLACK IS/ARE CLAIMED AS A FEATURE OF THE MARK.

THE MARK CONSISTS OF THE WORDING "CLOUDSMTP" IN BLACK, AND TO THE RIGHT OF THE WORDING, A SINGLE CLOUD IN GRADATED BLUE, WITH A WHITE ARROW POINTING FROM LEFT TO RIGHT THROUGH THE MIDDLE LEFT HALF OF THE CLOUD.

FOR ELECTRONIC MAIL SERVICES (U.S. CLS. 100, 101 AND 104).

FIRST USE 6-15-2010; IN COMMERCE 6-15-2010.  
PAULA MAHONEY, EXAMINING ATTORNEY

**CLASS 38—(Continued).**

SN 85-123,997. RILLAFLIX, LLC, BEVERLY HILLS, CA. FILED 9-7-2010.

Rillaflix

THE MARK CONSISTS OF STANDARD CHARACTERS WITHOUT CLAIM TO ANY PARTICULAR FONT, STYLE, SIZE, OR COLOR.

FOR STREAMING OF AUDIO, VISUAL AND AUDIO-VISUAL MATERIAL VIA A GLOBAL COMPUTER NETWORK; STREAMING OF VIDEO MATERIAL ON THE INTERNET; STREAMING OF HIGH DEFINITION AND STANDARD DEFINITION VIDEO, FEATURE LENGTH FILMS, SHORTS, WEBSISODES AND OTHER MOVING VISUAL ART FORMS MATERIAL ON THE INTERNET; VIDEO STREAMING SERVICES VIA THE INTERNET; FEATURING INDEPENDENT FILMS AND MOVIES (U.S. CLS. 100, 101 AND 104).

FIRST USE 3-1-2010; IN COMMERCE 3-1-2010.  
ALEX KEAM, EXAMINING ATTORNEY

SN 85-127,511. ONS, INC., TORRANCE, CA. FILED 9-11-2010.



NO CLAIM IS MADE TO THE EXCLUSIVE RIGHT TO USE "ONENUMBERSOLUTION", APART FROM THE MARK AS SHOWN.

THE MARK CONSISTS OF THE STYLIZED LETTERS "ONENUMBERSOLUTION", A STYLIZED "1" APPEARING WITHIN THE "N" OF "ONE", SPHERES ENCIRCLING THE LETTERS "ONE", SHADOWS OF THE SPHERES APPEARING DIRECTLY BELOW.

FOR TELECOMMUNICATION SERVICE PROVIDING INBOUND AND OUTBOUND VOICE, DATA, FAX, EMAIL, VOIP, SMS, VIDEO, CONFERENCING AND MOBILE COMMUNICATIONS INTO A SINGLE TELEPHONE PHONE NUMBER FOR INDIVIDUALS OR BUSINESSES (U.S. CLS. 100, 101 AND 104).

FIRST USE 8-27-2008; IN COMMERCE 8-27-2008.  
WILLIAM BRECKENFELD, EXAMINING ATTORNEY

**CLASS 38—(Continued).**

SN 85-137,549. SUGARMUSIC LUSITANA - SERVICOS, LDA., FUNCHAL, MADEIRA, PORTUGAL, FILED 9-24-2010.



OWNER OF PORTUGAL REG. NO. 354880, DATED 4-4-2003, EXPIRES 4-4-2013.

OWNER OF U.S. REG. NO. 2,829,011.

THE STIPPLING IS FOR SHADING PURPOSES ONLY. THE COLOR(S) DARK BLUE AND LIGHT BLUE IS/ARE CLAIMED AS A FEATURE OF THE MARK.

THE MARK CONSISTS OF A CIRCLE WITH A LIGHT AND DARK BLUE BORDER. THE CENTER OF THE CIRCLE IS DARK BLUE. THE WORD "SUGAR" IS IN DARK BLUE WITHIN A LIGHT BLUE BAND POSITIONED IN THE CENTER OF THE CIRCLE.

FOR TELECOMMUNICATION SERVICES WHICH ALLOW A PERSON TO GET IN ORAL AND VISUAL COMMUNICATION WITH ANOTHER, NAMELY, TRANSMISSION OF VOICE, DATA AND GRAPHICS BY MEANS OF TELEPHONE, TELEGRAPHIC, TELEVISION, RADIO, CABLE, COMPUTERNETWORK AND SATELLITE TRANSMISSIONS (U.S. CLS. 100, 101 AND 104).

ESTHER A. BORSUK, EXAMINING ATTORNEY

SN 85-138,281. BROWN, DONALD E., LOS ANGELES, CA. AND SAWYER, CHRISTOPHER, LOS ANGELES, CA. FILED 9-25-2010.



NO CLAIM IS MADE TO THE EXCLUSIVE RIGHT TO USE THE DESIGN OF THE GLOBE, APART FROM THE MARK AS SHOWN.

THE COLOR(S) BLUE, WHITE, RED, GRAY AND BLACK IS/ARE CLAIMED AS A FEATURE OF THE MARK.

THE MARK CONSISTS OF LETTERS "KGF" WITH THE COLORS BLUE, WHITE, RED APPEARING IN EACH LETTER; THERE IS A GLOBE IN THE BACKGROUND

**CLASS 38—(Continued).**

WITH THE COLORS GRAY, BLACK AND WHITE IN THE GLOBE; THE NORTH AMERICAN CONTINENT IS BLACK; THE PARTS OF THE CONTINENTS TO THE LEFT AND RIGHT OF NORTH AMERICA ARE IN THE COLOR WHITE; THE WATER REGIONS OF THE GLOBE APPEAR IN THE COLOR GRAY; THERE ARE BLACK VERTICAL RAYS EXTENDING FROM THE GLOBE TO THE LETTERS "KGFI" IN FRONT OF THE GLOBE; THE WORDING "WE'RE THE FUTURE!" IS BENEATH THE LETTERS "KGFI" AND APPEARS IN THE COLOR BLACK.

FOR INTERNET RADIO BROADCASTING SERVICES (U.S. CLS. 100, 101 AND 104).

GINA HAYES, EXAMINING ATTORNEY

---

SN 85-148,066. FALSTAD, TRAVIS, PLAYA VISTA, CA. FILED 10-8-2010.

**SKIP THE SMALL TALK**

THE MARK CONSISTS OF STANDARD CHARACTERS WITHOUT CLAIM TO ANY PARTICULAR FONT, STYLE, SIZE, OR COLOR.

FOR VIDEO CHAT ROOM SERVICES FOR SOCIAL NETWORKING; ADULT OR INFORMATIONAL VIDEO CHAT FOR MOBILE PHONE AND COMPUTER USERS (U.S. CLS. 100, 101 AND 104).

MICHAEL ENGEL, EXAMINING ATTORNEY

---

SN 85-149,906. AVI-SPL, INC., TAMPA, FL. FILED 10-11-2010.



NO CLAIM IS MADE TO THE EXCLUSIVE RIGHT TO USE "TELEPRESENCE", APART FROM THE MARK AS SHOWN.

THE MARK CONSISTS OF THREE SQUARE BOXES SIDE BY SIDE WITH A SILHOUETTE OF A LIZARD IN THE MIDDLE BOX ATOP A BRANCH WHICH EXTENDS INTO ALL 3 BOXES, ALL OVER THE WORD "CAMELEON" WHICH IS OVER THE WORD "TELEPRESENCE".

FOR AUDIO TELECONFERENCING; PROVIDING FACILITIES AND EQUIPMENT FOR TELEPRESENCE CONFERENCING; PROVIDING FACILITIES AND EQUIPMENT FOR VIDEO CONFERENCING; TELECONFERENCING AND VIDEO CONFERENCING SERVICES; TELEPRESENCE CONFERENCING SERVICES; WEB CONFERENCING SERVICES (U.S. CLS. 100, 101 AND 104).

FIRST USE 9-8-2010; IN COMMERCE 9-8-2010.  
LINDA M. KING, EXAMINING ATTORNEY

**CLASS 38—(Continued).**

SN 85-150,103. STEPHAN HEATH, DBA LAYER LINKS, GREENWOOD VILLAGE, CO. FILED 10-11-2010.

**LAYER LINKS**

THE MARK CONSISTS OF STANDARD CHARACTERS WITHOUT CLAIM TO ANY PARTICULAR FONT, STYLE, SIZE, OR COLOR.

FOR BROADCASTING PROGRAMS VIA A GLOBAL COMPUTER NETWORK; BROADCASTING SERVICES, NAMELY, TRANSMISSION OF ADVERTISING PROGRAMS AND MEDIA ADVERTISING COMMUNICATIONS VIA DIGITAL COMMUNICATIONS NETWORKS; CHAT ROOM SERVICES FOR SOCIAL NETWORKING; COMMUNICATION SERVICES, NAMELY, TRANSMISSION OF VOICE, AUDIO, VISUAL IMAGES AND DATA BY TELECOMMUNICATIONS NETWORKS, WIRELESS COMMUNICATION NETWORKS, THE INTERNET, INFORMATION SERVICES NETWORKS AND DATA NETWORKS; COMMUNICATION VIA FIBRE OPTICAL NETWORKS; COMMUNICATION VIA FIBRE-OPTIC NETWORKS; COMMUNICATION VIA OPTICAL FIBRE NETWORKS; COMMUNICATIONS VIA FIBER-OPTIC NETWORKS; COMMUNICATIONS VIA FIBRE-OPTIC NETWORKS; COMMUNICATIONS VIA MULTINATIONAL TELECOMMUNICATION NETWORKS; COMPUTER NETWORK ACCESS SERVICES BY MEANS OF A METRO ETHERNET; COMPUTER TRANSMISSION OF ONLINE BASED SERVICES ACCESSED VIA A NETWORK REFERENCE, NAMELY, A URI, VISUAL CODE, NAMELY, BARCODES, TAG, NAMELY, RFID, TERMINAL, NAMELY, PC OR MOBILE DEVICE, OR ANY COMBINATION THEREOF; CONSULTING IN THE FIELD OF TELECOMMUNICATION SERVICES, NAMELY, TRANSMISSION OF VOICE, DATA, AND DOCUMENTS VIA TELECOMMUNICATIONS NETWORKS; DIGITAL NETWORK TELECOMMUNICATIONS SERVICES; ELECTRONIC DELIVERY OF IMAGES AND PHOTOGRAPHS VIA A GLOBAL COMPUTER NETWORK; ELECTRONIC EXCHANGE OF DATA STORED IN DATABASES ACCESSIBLE VIA TELECOMMUNICATION NETWORKS; ELECTRONIC TRANSMISSION AND STREAMING OF DIGITAL MEDIA CONTENT FOR OTHERS VIA GLOBAL AND LOCAL COMPUTER NETWORKS; ELECTRONIC TRANSMISSION FOR OTHERS OF SECURITIES AND FINANCIAL INFORMATION VIA COMPUTER LINKING SERVICES, NAMELY, COMMUNICATING AND ROUTING TRADE INFORMATION INVOLVING ORDERS, ENTRY AND EXECUTION SERVICES, TO OTHERS VIA A GLOBAL COMPUTER NETWORK; HIGH BIT-RATE DATA TRANSMISSION SERVICES FOR TELECOMMUNICATION NETWORK OPERATORS; INFORMATION TRANSMISSION SERVICES VIA DIGITAL NETWORKS; INFORMATION TRANSMISSION VIA ELECTRONIC COMMUNICATIONS NETWORKS; INTERACTIVE DELIVERY OF VIDEO OVER DIGITAL NETWORKS; NETWORK CONFERENCING SERVICES; ON-LINE DOCUMENT DELIVERY VIA A GLOBAL COMPUTER NETWORK; PEER-TO-PEER NETWORK COMPUTER SERVICES, NAMELY, ELECTRONIC TRANSMISSION OF AUDIO, VIDEO AND OTHER DATA AND DOCUMENTS AMONG COMPUTERS; PROVIDING A HIGH SPEED ACCESS TO AREA NETWORKS AND A GLOBAL COMPUTER INFORMATION NETWORK; PROVIDING ACCESS TO TELECOMMUNICATION NETWORKS; PROVIDING ELECTRONIC TRANSMISSION OF CREDIT CARD TRANSACTION DATA AND ELECTRONIC PAYMENT DATA VIA A GLOBAL COMPUTER NETWORK; PROVIDING MULTIPLE USE ACCESS TO GLOBAL COMPUTER INFORMATION NETWORKS FOR THE TRANSFER AND DISSEMINATION OF A WIDE RANGE OF INFORMATION; PROVIDING MULTIPLE USER ACCESS TO PROPRIETARY COLLECTIONS OF INFORMATION BY MEANS OF GLOBAL COMPUTER INFORMATION NETWORKS; PROVIDING MULTIPLE-USER ACCESS TO A GLOBAL COMPUTER INFORMATION NETWORK; PROVIDING ON-LINE CHAT ROOMS FOR SOCIAL

**CLASS 38—(Continued).**

NETWORKING; PROVIDING PRIVATE AND SECURE REAL TIME ELECTRONIC COMMUNICATION OVER A COMPUTER NETWORK; PROVIDING TELECOMMUNICATIONS CONNECTIONS TO A GLOBAL COMPUTER NETWORK; PROVIDING USER ACCESS TO A GLOBAL COMPUTER NETWORK; PROVIDING USER ACCESS TO COMPUTER PROGRAMMES IN DATA NETWORKS; PROVISION OF ACCESS TO A GLOBAL COMPUTER NETWORK; RENTAL OF ACCESS TIME TO GLOBAL COMPUTER NETWORKS; SATELLITE, CABLE, NETWORK TRANSMISSION OF SOUNDS, IMAGES, SIGNALS AND DATA; STREAMING OF AUDIO, VISUAL AND AUDIOVISUAL MATERIAL VIA A GLOBAL COMPUTER NETWORK; TELECOMMUNICATION SERVICES, NAMELY, LOCAL AND LONG DISTANCE TRANSMISSION OF VOICE, DATA, GRAPHICS AND VIDEO BY MEANS OF BROADBAND OPTICAL OR WIRELESS NETWORKS; TELECOMMUNICATION SERVICES, NAMELY, LOCAL AND LONG DISTANCE TRANSMISSION OF VOICE, DATA, GRAPHICS AND VIDEO BY MEANS OF BROADBAND, COPPER AND OPTICAL OR WIRELESS NETWORKS; TELECOMMUNICATION SERVICES, NAMELY, PROVIDING INTERNET ACCESS VIA BROADBAND OPTICAL OR WIRELESS NETWORKS; TELECOMMUNICATION SERVICES, NAMELY, TRANSMISSION OF VOICE, DATA, GRAPHICS, IMAGES, AUDIO AND VIDEO BY MEANS OF TELECOMMUNICATIONS NETWORKS, WIRELESS COMMUNICATION NETWORKS, AND THE INTERNET; TELECOMMUNICATION SERVICES, NAMELY, TRANSMISSION OF VOICE, DATA, GRAPHICS, SOUND AND VIDEO BY MEANS OF BROADBAND POWER LINE OR WIRELESS NETWORKS; TELECOMMUNICATIONS SERVICES FOR PROVIDING MULTIPLE-USER ACCESS TO A GLOBAL COMPUTER NETWORK; TELECOMMUNICATIONS SERVICES, NAMELY, PROVIDING FIBER OPTIC NETWORK SERVICES; TRANSMISSION AND DISTRIBUTION OF DATA OR AUDIO VISUAL IMAGES VIA A GLOBAL COMPUTER NETWORK OR THE INTERNET; TRANSMISSION AND RECEPTION OF DATABASE INFORMATION VIA THE TELECOMMUNICATION NETWORK; TRANSMISSION OF DATABASE INFORMATION VIA TELECOMMUNICATIONS NETWORKS; TRANSMISSION OF INFORMATION BY ELECTRONIC COMMUNICATIONS NETWORKS; TRANSMISSION OF INFORMATION ON OPTICAL TELECOMMUNICATION NETWORKS; TRANSMISSION OF INFORMATION VIA COMPUTERS CONNECTED TO THE SAME TELEMATIC NETWORK; TRANSMISSION OF INFORMATION VIA NATIONAL AND INTERNATIONAL NETWORKS; TRANSMISSION OF SOUND AND VISION VIA SATELLITE OR INTERACTIVE MULTIMEDIA NETWORKS; VIDEO BROADCASTING SERVICES OVER THE INTERNET OR OTHER COMMUNICATIONS NETWORK FEATURING THE UPLOADED, POSTED AND TAGGED VIDEOS OF OTHERS; VIDEO BROADCASTING SERVICES OVER THE INTERNET OR OTHER COMMUNICATIONS NETWORK, NAMELY, ELECTRONICALLY TRANSMITTING VIDEO CLIPS; VIDEO TRANSMISSION OVER DIGITAL NETWORKS (U.S. CLS. 100, 101 AND 104).

JOHN HWANG, EXAMINING ATTORNEY

**CLASS 38—(Continued).**

SN 85-159,884. VALUE PLUS MOBILE, WOODLAND HILLS, CA. FILED 10-24-2010.

## Value + Mobile

THE MARK CONSISTS OF STANDARD CHARACTERS WITHOUT CLAIM TO ANY PARTICULAR FONT, STYLE, SIZE, OR COLOR.

NO CLAIM IS MADE TO THE EXCLUSIVE RIGHT TO USE "MOBILE", APART FROM THE MARK AS SHOWN.

FOR WIRELESS TELEPHONE TELECOMMUNICATIONS SERVICES, NAMELY, WIRELESS MOBILE TELEPHONE CALLING PLANS (U.S. CLS. 100, 101 AND 104).

FIRST USE 10-1-2010; IN COMMERCE 10-1-2010.  
MICHAEL SOUDERS, EXAMINING ATTORNEY

SN 85-166,179. DOTCOM SOFTWARE TECHNOLOGIES II LLC, DBA DINGLE VOICE, VIRGINIA BEACH, VA. FILED 11-1-2010.



NO CLAIM IS MADE TO THE EXCLUSIVE RIGHT TO USE "VOICE", APART FROM THE MARK AS SHOWN.

THE COLOR(S) GREEN AND ORANGE IS/ARE CLAIMED AS A FEATURE OF THE MARK.

THE MARK CONSISTS OF "DINGLE" IS GREEN, THE DOT IN THE I IS ORANGE, THE E IS A TELEPHONE HEADSET, THE ORANGE CORD GOES FROM THE N TO THE E AND "VOICE" IS ORANGE.

FOR RENTAL OF TELECOMMUNICATION EQUIPMENT INCLUDING TELEPHONES AND FACSIMILE APPARATUS; TELECOMMUNICATION SERVICES IN THE NATURE OF PROVIDING TELEPHONE SERVICES WITH VARIOUS TELEPHONE FEATURES, NAMELY, A DEDICATED TOLL-FREE NUMBER, VOICEMAIL, MULTIPLE MAILBOX EXTENSIONS, TELEPHONE MESSAGE NOTIFICATION, FAX CAPABILITIES, DETAILED CALLREPORTS, CALL WAITING, CALL IDENTIFICATION, CALL FORWARDING, AND MESSAGE WAITING; TELECOMMUNICATION SERVICES, NAMELY, LOCAL AND LONG DISTANCE TRANSMISSION OF VOICE, DATA, GRAPHICS AND VIDEO BY MEANS OF BROADBAND OPTICAL OR WIRELESS NETWORKS (U.S. CLS. 100, 101 AND 104).

FIRST USE 10-1-2010; IN COMMERCE 10-1-2010.  
BENJAMIN OKEKE, EXAMINING ATTORNEY



**CLASS 38—(Continued).**

SN 85-172,897. CHUNGHWA TELECOM GLOBAL, INC., SAN JOSE, CA. FILED 11-9-2010.



THE COLOR(S) BLUE, BLACK AND GRAY IS/ARE CLAIMED AS A FEATURE OF THE MARK.

THE MARK CONSISTS OF THE WORDING "CHTGLOBAL DEDICATED TO COMMUNICATIONS". THE WORDING "CHT" IS IN GRAY, THE WORD "GLOBAL" IS IN BLUE AND THE WORDS "DEDICATED TO COMMUNICATIONS" IS IN BLACK. THERE IS A STYLIZED DESIGN OF THE LETTERS "CG" IN A CIRCLE THAT IS BLACK AND FADES TO BLUE ON THE INSIDE WITH CUTOUTS FOR THE LETTERS INSIDE THE CIRCLE.

FOR TELECOMMUNICATIONS SERVICES, NAMELY, PROVIDING LOCAL, LONG, AND INTERNATIONAL DISTANCE TRANSMISSION OF VOICE, DATA AND GRAPHICS BY MEANS OF TELEPHONE, TELEGRAPHIC, CABLE AND SATELLITE TRANSMISSIONS; TELECOMMUNICATIONS BY E-MAIL; PROVIDING FACILITIES AND EQUIPMENT FOR VIDEO CONFERENCING; PROVIDING MULTIPLE USER BROADBAND AND DEDICATED ACCESS TO THE INTERNET; VIDEO-ON-DEMAND TRANSMISSION SERVICES; STREAMING OF AUDIO AND VIDEO MATERIAL ON THE INTERNET; RADIO, TELEVISION AND VIDEO BROADCASTING AND TRANSMISSION SERVICES; COMPUTER SERVICES TO ENABLE MULTI-USER ACCESS TO VIRTUAL PRIVATE NETWORK (VPN) AND INTERNATIONAL PRIVATE LEASED NETWORKS (U.S. CLS. 100, 101 AND 104).

FIRST USE 9-28-2010; IN COMMERCE 9-28-2010.  
DAWN FELDMAN, EXAMINING ATTORNEY

SN 85-175,698. SUPERSTATION, INC., ATLANTA, GA. FILED 11-12-2010.

**TURN HERE FOR FUN**

THE MARK CONSISTS OF STANDARD CHARACTERS WITHOUT CLAIM TO ANY PARTICULAR FONT, STYLE, SIZE, OR COLOR.

FOR TELEVISION BROADCASTING SERVICES (U.S. CLS. 100, 101 AND 104).

DAVID COLLIER, EXAMINING ATTORNEY

**CLASS 38—(Continued).**

SN 85-176,497. TABLE TOP TELEPHONE COMPANY, INC., AJO, AZ. FILED 11-15-2010.

**DuraCare**

THE MARK CONSISTS OF STANDARD CHARACTERS WITHOUT CLAIM TO ANY PARTICULAR FONT, STYLE, SIZE, OR COLOR.

FOR INTERNET ACCESS PROVIDER SERVICES; INTERNET TELEPHONY SERVICES; TELECOMMUNICATION SERVICES, NAMELY, PROVIDING INTERNET ACCESS VIA BROADBAND OPTICAL OR WIRELESS NETWORKS; TELECOMMUNICATIONS RESELLER SERVICES FOR BUSINESSES, NAMELY, PROVIDING LONG DISTANCE TELECOMMUNICATION SERVICES, VOICE TELECOMMUNICATION SERVICES, LOCAL TELEPHONE SERVICE, AND INTERNET ACCESS SERVICES (U.S. CLS. 100, 101 AND 104).

ANDREW RHIM, EXAMINING ATTORNEY

SN 85-177,965. IQUP TECHNOLOGIES LLC, WINSTON-SALEM, NC. FILED 11-16-2010.

**mobilepronto**

THE MARK CONSISTS OF STANDARD CHARACTERS WITHOUT CLAIM TO ANY PARTICULAR FONT, STYLE, SIZE, OR COLOR.

FOR TELECOMMUNICATIONS GATEWAY SERVICES, NAMELY SENDING AND MANAGING MESSAGES THROUGH GATEWAY TECHNOLOGIES, AND PLATFORMS, AND EDUCATIONAL TEXT MESSAGING SERVICES FOR TRANSMISSION OF EDUCATIONAL CONTENT VIA SMS (U.S. CLS. 100, 101 AND 104).

FIRST USE 1-1-2008; IN COMMERCE 1-1-2008.  
SUSAN STIGLITZ, EXAMINING ATTORNEY

SN 85-178,209. PROFESSIONAL RECREATION ORGANIZATION, INC., BELLEVUE, WA. FILED 11-16-2010.

**20/20 BE WELL**

THE MARK CONSISTS OF STANDARD CHARACTERS WITHOUT CLAIM TO ANY PARTICULAR FONT, STYLE, SIZE, OR COLOR.

FOR PROVIDING ON-LINE ELECTRONIC BULLETIN BOARDS AND FORUMS FOR TRANSMISSION OF MESSAGES AMONG COMPUTER USERS CONCERNING HEALTH, NUTRITION AND WEIGHT-LOSS TRACKING, MANAGEMENT AND EDUCATION (U.S. CLS. 100, 101 AND 104).

BRENDAN REGAN, EXAMINING ATTORNEY

**CLASS 38—(Continued).**

SN 85-179,654. WIBG, LLC, ALLENTOWN, NJ. FILED 11-18-2010.

# Wibbage

THE MARK CONSISTS OF STANDARD CHARACTERS WITHOUT CLAIM TO ANY PARTICULAR FONT, STYLE, SIZE, OR COLOR.

OWNER OF U.S. REG. NO. 3,863,743.  
FOR INTERNET RADIO BROADCASTING SERVICES;  
RADIO BROADCASTING (U.S. CLS. 100, 101 AND 104).  
FIRST USE 1-1-1993; IN COMMERCE 1-1-1993.  
SARA BENJAMIN, EXAMINING ATTORNEY

**CLASS 39—(Continued).**

SN 77-844,705. AEKO KULA, INC., HONOLULU, HI. FILED 10-8-2009.

# ALOHA FLEXSHIP

THE MARK CONSISTS OF STANDARD CHARACTERS WITHOUT CLAIM TO ANY PARTICULAR FONT, STYLE, SIZE, OR COLOR.

FOR TRANSPORTATION AND DELIVERY SERVICES FOR PACKAGES, CARGO AND PERSONAL PROPERTY BY AIR (U.S. CLS. 100 AND 105).  
FIRST USE 6-5-2009; IN COMMERCE 6-5-2009.  
KIMBERLY FRYE, EXAMINING ATTORNEY

**CLASS 39—TRANSPORTATION AND STORAGE**

SN 77-838,949. CANADA GOOSE INC., TORONTO ONTARIO M6B1G7, CANADA, FILED 10-1-2009.



PRIORITY CLAIMED UNDER SEC. 44(D) ON CANADA APPLICATION NO. 1451313, FILED 9-10-2009, REG. NO. TMA778,551, DATED 9-30-2010, EXPIRES 9-30-2025.

OWNER OF U.S. REG. NO. 3,254,771.  
NO CLAIM IS MADE TO THE EXCLUSIVE RIGHT TO USE "THE REPRESENTATION OF THE ELEVEN-POINT MAPLE LEAF DESIGN" AND "ADVENTURE TOURS", APART FROM THE MARK AS SHOWN.

THE MARK CONSISTS OF A MAP OF THE WORLD OVER A COMPASS ROSE, ALL WITHIN THE OUTLINE OF A CIRCLE. ABOVE THE CIRCLE ARE THE DOWNWARD-ARCHING WORDS, "CANADA GOOSE". TO EACH SIDE OF THE CIRCLE IS ONE MAPLE LEAF DESIGN. BELOW THE CIRCLE ARE THE WORDS ARCHING UPWARDS, "ADVENTURE TOURS". THIS ENTIRE DESIGN IS WITHIN A THICKER OUTLINE OF A CIRCLE.

FOR TRAVEL AND TOUR SERVICES, NAMELY, ARRANGING AND COORDINATING TRAVEL ARRANGEMENTS FOR INDIVIDUALS AND GROUPS, ARRANGING TRAVEL TOURS, ORGANIZATION OF EXCURSIONS, TOURS AND TRAVEL; ARRANGING AND OPERATING ADVENTURE ACTIVITY TOURS AND EXCURSIONS (U.S. CLS. 100 AND 105).  
DARRYL SPRUILL, EXAMINING ATTORNEY

SN 77-932,890. INNOV8 TRANSPORT INC., AUSTIN, TX. FILED 2-10-2010.



THE COLOR(S) DARK GREEN AND LIME GREEN AND BLACK IS/ARE CLAIMED AS A FEATURE OF THE MARK. THE MARK CONSISTS OF THE WORDING "SKY-FREIGHT" IN STYLIZED FORM, WITH AN ARROW DESIGN RUNNING FROM LEFT TO RIGHT THROUGH THE LETTERS "SKY" AND ABOVE THE LETTERS "FREIGHT". THE LETTERS "SKY" ARE IN DARK GREEN, THE LETTERS "FREIGHT" ARE IN BLACK, AND THE ARROW IS COMPOSED OF ALTERNATING DARK GREEN AND LIME GREEN.

FOR TRANSPORTATION SERVICES, NAMELY, TRANSPORTING COMMERCIAL CARGO ON LARGE ELECTRIC VEHICLES THAT ARE EQUIPPED TO USE ELECTRIFIED HIGHWAYS (U.S. CLS. 100 AND 105).  
JANET LEE, EXAMINING ATTORNEY

SN 77-961,370. RRK WALKER, INC., MILFORD, MA. FILED 3-17-2010.



NO CLAIM IS MADE TO THE EXCLUSIVE RIGHT TO USE "POSTAL CENTER", APART FROM THE MARK AS SHOWN.

THE MARK CONSISTS OF A DESIGN CONSISTING OF INTERLOCKING CIRCLES ON THE LEFT AND THE MARK "POSTALCENTER" ON THE RIGHT.

FOR PACKAGING ARTICLES FOR TRANSPORTATION; PARCEL SHIPPING SERVICES; POSTAL SERVICES, NAMELY, PARCEL DELIVERY, PACKAGING ARTICLES FOR TRANSPORTATION, RENTAL OF MAILBOXES; SHIPPING OF GOODS (U.S. CLS. 100 AND 105).

FIRST USE 1-31-2010; IN COMMERCE 1-31-2010.  
MARIAM MAHMOUDI, EXAMINING ATTORNEY

**CLASS 39—(Continued).**

SN 77-965,567. MERCHANTS TERMINAL CORPORATION, BALTIMORE, MD. FILED 3-23-2010.

**MTC LOGISTICS**

THE MARK CONSISTS OF STANDARD CHARACTERS WITHOUT CLAIM TO ANY PARTICULAR FONT, STYLE, SIZE, OR COLOR.

NO CLAIM IS MADE TO THE EXCLUSIVE RIGHT TO USE "LOGISTICS", APART FROM THE MARK AS SHOWN.

FOR WAREHOUSING SERVICES; TRANSPORTATION SERVICES, NAMELY, CONSOLIDATION OF GOODS THAT ARE LESS THAN A FULL TRUCKLOAD INTO FULL TRUCKLOADS FOR TRANSPORTATION PURPOSES, AND TRANSPORT OF GOODS; DRAYAGE SERVICES; COLD STORAGE SERVICES; IMPORT AND EXPORT AGENCIES; TRANSPORTATION OF GOODS BY RAIL; TRUCKING SERVICES, NAMELY, HAULING OF FOOD PRODUCTS; LABELING SERVICES, NAMELY, IDENTIFICATION OF GOODS TO BE TRANSPORTED; REPACKING ARTICLES FOR TRANSPORTATION; RAIL, TRUCK, AND CONTAINER TRANSLOADING SERVICES; BREAK-BULK AND GENERAL CARGO HANDLING SERVICES; TRANSPORT OF GOODS IN REFRIGERATED CONTAINERS (U.S. CLS. 100 AND 105).

INGA ERVIN, EXAMINING ATTORNEY

**CLASS 39—(Continued).**

SN 85-003,267. WICHITA DOWNTOWN DEVELOPMENT CORPORATION, WICHITA, KS. FILED 3-31-2010.



THE COLOR(S) GREEN, YELLOW, BLUE IS/ARE CLAIMED AS A FEATURE OF THE MARK.

THE MARK CONSISTS OF THREE CIRCLES WITH THE FIRST BEING GREEN AND CONTAINING A QUESTION MARK INSIDE, THE SECOND BEING YELLOW AND CONTAINING A "2" AND THE THIRD BEING BLUE AND CONTAINING A "P".

FOR CAR PARKING; VEHICLE PARKING; VEHICLE PARKING SERVICES RELATING TO THE AVAILABILITY OF ON-STREET AND OFF-STREET PARKING SPACES (U.S. CLS. 100 AND 105).

FIRST USE 11-23-2009; IN COMMERCE 12-14-2009.

JACQUELINE A. LAVINE, EXAMINING ATTORNEY

SN 77-965,571. MERCHANTS TERMINAL CORPORATION, BALTIMORE, MD. FILED 3-23-2010.



NO CLAIM IS MADE TO THE EXCLUSIVE RIGHT TO USE "LOGISTICS", APART FROM THE MARK AS SHOWN.

THE MARK CONSISTS OF THE WORDS "MTC LOGISTICS" UNDER A PLURALITY OF CUBES FORMED AS A STYLIZED LETTER "M".

FOR WAREHOUSING SERVICES; TRANSPORTATION SERVICES, NAMELY, CONSOLIDATION OF GOODS THAT ARE LESS THAN A FULL TRUCKLOAD INTO FULL TRUCKLOADS FOR TRANSPORTATION PURPOSES, AND TRANSPORT OF GOODS; DRAYAGE SERVICES; COLD STORAGE SERVICES; IMPORT AND EXPORT AGENCIES; TRANSPORTATION OF GOODS BY RAIL; TRUCKING SERVICES, NAMELY, HAULING OF FOOD PRODUCTS; LABELING SERVICES, NAMELY, IDENTIFICATION OF GOODS TO BE TRANSPORTED; REPACKING ARTICLES FOR TRANSPORTATION; RAIL, TRUCK, AND CONTAINER TRANSLOADING SERVICES; BREAK-BULK AND GENERAL CARGO HANDLING SERVICES; TRANSPORT OF GOODS IN REFRIGERATED CONTAINERS (U.S. CLS. 100 AND 105).

INGA ERVIN, EXAMINING ATTORNEY

SN 85-012,944. PROJECT EVIE, INC., NEW YORK, NY. FILED 4-13-2010.



NO CLAIM IS MADE TO THE EXCLUSIVE RIGHT TO USE "PROJECT", APART FROM THE MARK AS SHOWN.

THE MARK CONSISTS OF THE WORD "PROJECT" IN UPPER AND LOWER CASE POSITIONED ABOVE "EVIE" IN LOWER CASE WITH A PAIR OF LEAVES SUBSTITUTED FOR THE DOT OVER THE "I" AND THE FINAL "E" DEPICTED AS A CURVING WIRE ENDING IN A PLUG.

FOR ARRANGING AND CONDUCTING A WORLD-WIDE EXPEDITION IN AN ELECTRIC VEHICLE; AND PROVIDING AN INTERNET WEBSITE FEATURING NEWS AND GENERAL INFORMATION ABOUT ENVIRONMENTALLY SUSTAINABLE TRANSPORTATION INCLUDING ELECTRIC VEHICLES (U.S. CLS. 100 AND 105).

BENJAMIN OKEKE, EXAMINING ATTORNEY

**CLASS 39—(Continued).**

SN 85-014,627. ANIMAL AIRWAYS LTD, WEMBLEY, UNITED KINGDOM, FILED 4-15-2010.



NO CLAIM IS MADE TO THE EXCLUSIVE RIGHT TO USE "ANIMAL AIRWAYS", APART FROM THE MARK AS SHOWN.

THE COLOR(S) DARK BLUE (PANTONE 281 C) AND ORANGE (PANTONE 172 C) IS/ARE CLAIMED AS A FEATURE OF THE MARK.

THE MARK CONSISTS OF AN ABSTRACT DESIGN SPLIT IN TWO, OF WHICH THE UPPER PART IS DARK BLUE AND THE LOWER PART IS ORANGE. THERE IS A DARK BLUE CIRCLE OVER THE UPPER PART OF THE DESIGN AND AN ORANGE CIRCLE TO THE RIGHT OF THE BLUE PART OF THE DESIGN AND ABOVE THE ORANGE PART. THE DESIGN AND CIRCLES ARE OVER THE WORDS "ANIMAL AIRWAYS", IN WHICH THE WORD "ANIMAL" IS IN ORANGE AND THE WORD "AIRWAYS" IS IN DARK BLUE.

FOR TRAVEL AGENCY SERVICES FOR PEOPLE TRAVELING WITH THEIR ANIMALS, NAMELY, MAKING RESERVATIONS AND BOOKINGS FOR TRANSPORTATION; ARRANGING TRAVEL TRANSIT FOR ANIMALS (U.S. CLS. 100 AND 105).

FIRST USE 1-1-2010; IN COMMERCE 1-1-2010.  
DANNEAN HETZEL, EXAMINING ATTORNEY

**CLASS 39—(Continued).**

SN 85-019,685. LYNDEN INCORPORATED, SEATTLE, WA. FILED 4-21-2010.



THE MARK CONSISTS OF A COW HEAD WITH LEFT EYE WINKING AND POLKA DOT BOW TIE ON TOP OF COW HEAD WITH THE WORDS "DRINKAMUGAMILKAMEAL!" TO THE RIGHT OF THE COW HEAD.

FOR TRANSPORTATION AND STORAGE OF GOODS IN REFRIGERATED CONDITIONS (U.S. CLS. 100 AND 105).

FIRST USE 1-1-1972; IN COMMERCE 1-1-1972.  
BILL DAWE, EXAMINING ATTORNEY

SN 85-020,639. AEROVIAS DE INTEGRACION REGIONAL S.A. (AIRES S.A.), BOGOTA, D.C., COLOMBIA, FILED 4-22-2010.



THE COLOR(S) BLUE, GREEN AND WHITE IS/ARE CLAIMED AS A FEATURE OF THE MARK.

THE MARK CONSISTS OF THE TERM "AAAAA" IN BLUE AND ORIENTED IN A CIRCULAR PATTERN SUPERIMPOSED OVER A GREEN POLYGON DESIGN AND THE TERM "AIRES" IN WHITE WITH THE LEFT EDGE OF THE FIRST LETTER PARALLEL TO THE RIGHT EDGE OF THE POLYGON DESIGN, ALL SUPERIMPOSED OVER A BLUE RECTANGULAR BACKGROUND.

THE ENGLISH TRANSLATION OF "AIRES" IN THE MARK IS "AIRS".

FOR AIR TRANSPORT; AIR TRANSPORTATION, FREIGHT TRANSPORTATION BY AIR; TRANSPORTATION OF PASSENGERS, GOODS AND MAIL BY AIR; COURIER SERVICES; TRAVEL GUIDE SERVICES; TRAVEL AGENCY SERVICES, NAMELY, ARRANGING AND MAKING RESERVATIONS AND BOOKING FOR AIR AND INLAND TRANSPORTATION, AND ARRANGING, MAKING RESERVATIONS AND BOOKING FOR OTHER TRAVEL AGENCIES AND DIRECTLY TO CONSUMERS OF AIR TRANSPORTATION, INLAND TRANSPORTATION AND CRUISES AS PARTS OF TOUR PACKAGES; TRAVEL INFORMATION SERVICES (U.S. CLS. 100 AND 105).

JOHN DWYER, EXAMINING ATTORNEY

SN 85-017,188. RUBBERMAID INCORPORATED, ATLANTA, GA. FILED 4-19-2010.

**CLOSET AT A TIME**

THE MARK CONSISTS OF STANDARD CHARACTERS WITHOUT CLAIM TO ANY PARTICULAR FONT, STYLE, SIZE, OR COLOR.

NO CLAIM IS MADE TO THE EXCLUSIVE RIGHT TO USE "CLOSET", APART FROM THE MARK AS SHOWN.

FOR PACKAGING ARTICLES, NAMELY, INDIVIDUAL COMPONENTS FOR CLOSETS AND HOME STORAGE SYSTEMS, TO THE ORDER AND SPECIFICATION OF OTHERS, NAMELY, CONTRACTORS, ON A CUSTOM ORDER BASIS AND PALLET SHIPPING OF SAID PACKAGES TO CONTRACTORS (U.S. CLS. 100 AND 105).

ANDREA K. NADELMAN, EXAMINING ATTORNEY

**CLASS 39—(Continued).**

SN 85-020,732. AEROVIAS DE INTEGRACION REGIONAL S.A. (AIRES S.A.), BOGOTA, D.C., COLOMBIA, FILED 4-22-2010.



THE COLOR(S) BLUE, GREEN, WHITE AND BLACK IS/ARE CLAIMED AS A FEATURE OF THE MARK.

THE MARK CONSISTS OF THE TERM "AAAAA" IN BLUE AND ORIENTED IN A CIRCULAR PATTERN SUPERIMPOSED OVER A GREEN POLYGON DESIGN AND THE TERM "AIRES" IN BLUE WITH THE LEFT EDGE OF THE FIRST LETTER PARALLEL TO THE RIGHT EDGE OF THE POLYGON DESIGN, ALL SUPERIMPOSED OVER A WHITE RECTANGULAR BACKGROUND WITH BLACK BORDERS.

THE ENGLISH TRANSLATION OF "AIRES" IN THE MARK IS "AIRS".

FOR AIR TRANSPORT; AIR TRANSPORTATION, FREIGHT TRANSPORTATION BY AIR; TRANSPORTATION OF PASSENGERS, GOODS AND MAIL BY AIR; COURIER SERVICES; TRAVEL GUIDE SERVICES; TRAVEL AGENCY SERVICES, NAMELY, ARRANGING AND MAKING RESERVATIONS AND BOOKING FOR AIR AND INLAND TRANSPORTATION, AND ARRANGING, MAKING RESERVATIONS AND BOOKING FOR OTHER TRAVEL AGENCIES AND DIRECTLY TO CONSUMERS OF AIR TRANSPORTATION, INLAND TRANSPORTATION AND CRUISES AS PARTS OF TOUR PACKAGES; TRAVEL INFORMATION SERVICES (U.S. CLS. 100 AND 105).

JOHN DWYER, EXAMINING ATTORNEY

SN 85-020,772. AEROVIAS DE INTEGRACION REGIONAL S.A. (AIRES S.A.), BOGOTA, D.C., COLOMBIA, FILED 4-22-2010.



THE COLOR(S) BLUE, LIGHT GREEN, DARK GREEN AND WHITE IS/ARE CLAIMED AS A FEATURE OF THE MARK.

THE MARK CONSISTS OF THE TERMS "PLANES" AND "AIRES", LOCATED TO THE RIGHT OF A LIGHT GREEN POLYGON WITH A CIRCULAR DESIGN SUPERIMPOSED

**CLASS 39—(Continued).**

OVER IT, THE CIRCULAR DESIGN HAVING THE APPEARANCE OF A PARTIALLY TRANSPARENT GLOBE WITH A SMEARED WHITE, LIGHT GREEN, DARK GREEN, AND BLUE SWIRL DESIGN ON ITS SURFACE, THE TERM "PLANES" HAVING A GREEN GRADIENT PATTERN CHANGING FROM LIGHT GREEN AT THE TOP OF THE LETTERS TO DARK GREEN AT THE BOTTOM OF THE LETTERS, THE TERM "AIRES" IN BLUE WITH THE LEFT EDGE OF THE FIRST LETTER PARALLEL TO THE RIGHT EDGE OF THE LIGHT GREEN POLYGON DESIGN.

THE ENGLISH TRANSLATION OF "AIRES" AND "PLANES" IN THE MARK IS "AIRS" AND "PLANS" RESPECTIVELY.

FOR AIR TRANSPORT; AIR TRANSPORTATION, FREIGHT TRANSPORTATION BY AIR; TRANSPORTATION OF PASSENGERS, GOODS AND MAIL BY AIR; COURIER SERVICES; TRAVEL GUIDE SERVICES; TRAVEL AGENCY SERVICES, NAMELY, ARRANGING AND MAKING RESERVATIONS AND BOOKING FOR AIR AND INLAND TRANSPORTATION, AND ARRANGING, MAKING RESERVATIONS AND BOOKING FOR OTHER TRAVEL AGENCIES AND DIRECTLY TO CONSUMERS OF AIR TRANSPORTATION, INLAND TRANSPORTATION AND CRUISES AS PARTS OF TOUR PACKAGES; TRAVEL INFORMATION SERVICES (U.S. CLS. 100 AND 105).

JOHN DWYER, EXAMINING ATTORNEY

SN 85-020,794. AEROVIAS DE INTEGRACION REGIONAL S.A. (AIRES S.A.), BOGOTA, D.C., COLOMBIA, FILED 4-22-2010.



THE COLOR(S) BLUE, LIGHT GREEN, DARK GREEN AND WHITE IS/ARE CLAIMED AS A FEATURE OF THE MARK.

THE MARK CONSISTS OF THE TERMS "PLANES" AND "AIRES", LOCATED TO THE RIGHT OF A LIGHT GREEN POLYGON WITH A CIRCULAR DESIGN SUPERIMPOSED OVER IT, THE CIRCULAR DESIGN HAVING THE APPEARANCE OF A PARTIALLY TRANSPARENT GLOBE WITH A SMEARED WHITE, LIGHT GREEN, DARK GREEN, AND BLUE SWIRL DESIGN ON ITS SURFACE, THE TERM "PLANES" HAVING A GREEN GRADIENT PATTERN CHANGING FROM LIGHT GREEN AT THE TOP OF THE LETTERS TO DARK GREEN AT THE BOTTOM OF THE LETTERS, THE TERM "AIRES" IN WHITE WITH THE LEFT EDGE OF THE FIRST LETTER PARALLEL TO THE RIGHT EDGE OF THE LIGHT GREEN POLYGON DESIGN, ALL SUPERIMPOSED OVER A BLUE RECTANGULAR BACKGROUND.

THE ENGLISH TRANSLATION OF "AIRES" AND "PLANES" IN THE MARK IS "AIRS" AND "PLANS" RESPECTIVELY.

FOR AIR TRANSPORT; AIR TRANSPORTATION, FREIGHT TRANSPORTATION BY AIR; TRANSPORTATION OF PASSENGERS, GOODS AND MAIL BY AIR; COURIER SERVICES; TRAVEL GUIDE SERVICES; TRAVEL AGENCY SERVICES, NAMELY, ARRANGING AND MAKING RESERVATIONS AND BOOKING FOR AIR AND INLAND TRANSPORTATION, AND ARRANGING, MAKING RESERVATIONS AND BOOKING FOR OTHER TRAVEL AGENCIES AND DIRECTLY TO CONSUMERS OF AIR TRANSPORTATION, INLAND TRANSPORTATION AND CRUISES AS PARTS OF TOUR PACKAGES; TRAVEL INFORMATION SERVICES (U.S. CLS. 100 AND 105).

JOHN DWYER, EXAMINING ATTORNEY

**CLASS 39—(Continued).**

SN 85-029,936. MAC HOLFAM INTERNATIONAL, S.L., ALCOBENDAS (MADRID), SPAIN, FILED 5-4-2010.



OWNER OF ERPN CMNTY TM OFC REG. NO. 005680392, DATED 1-9-2009, EXPIRES 1-31-2017.

THE MARK CONSISTS OF THE WORD "GESTAIR" WITH A STYLIZED LETTER "G" ABOVE.

FOR STORAGE OF AIRSHIPS AND THEIR EQUIPMENTS AND SPARE PARTS; SERVICES OF AIR TRANSPORT OF PASSENGERS AND MERCHANDISES (U.S. CLS. 100 AND 105).

MAYUR VAGHANI, EXAMINING ATTORNEY

SN 85-065,964. RYL, LLC, LOS ANGELES, CA. FILED 6-17-2010.



NO CLAIM IS MADE TO THE EXCLUSIVE RIGHT TO USE "PRIVATE-AVIATION" AND "CO.", APART FROM THE MARK AS SHOWN.

THE MARK CONSISTS OF A CROWN WITH WINGS ON EITHER SIDE AND THE LETTERS "RYL" TO THE RIGHT WITH THE WORDS "A PRIVATE-AVIATION & LIFESTYLE CO." BELOW THE CROWN, WINGS, AND LETTERS "RYL".

FOR TRAVEL AGENCY SERVICES, NAMELY, MAKING RESERVATIONS AND BOOKINGS FOR TRANSPORTATION (U.S. CLS. 100 AND 105).

FIRST USE 2-1-2010; IN COMMERCE 2-1-2010.

NAKIA HENRY, EXAMINING ATTORNEY

SN 85-128,656. PEPPERMILL CASINOS, INC., RENO, NV. FILED 9-13-2010.

**WENDOVER FLYAWAY**

THE MARK CONSISTS OF STANDARD CHARACTERS WITHOUT CLAIM TO ANY PARTICULAR FONT, STYLE, SIZE, OR COLOR.

NO CLAIM IS MADE TO THE EXCLUSIVE RIGHT TO USE "WENDOVER", APART FROM THE MARK AS SHOWN.

FOR COORDINATING AIR TRAVEL ARRANGEMENTS FOR INDIVIDUALS AND FOR GROUPS; ONLINE TRIP AND TRAVEL RESERVATION SERVICES FOR AIR TRAVEL; RESERVATION AND BOOKING OF SEATS FOR AIR TRAVEL; AIR TRAVEL AND TOUR INFORMATION SERVICE; AIR TRAVEL AND TOUR TICKET RESERVATION SERVICE (U.S. CLS. 100 AND 105).

FIRST USE 6-25-2010; IN COMMERCE 6-25-2010.

JOHN KELLY, EXAMINING ATTORNEY

**CLASS 39—(Continued).**

SN 85-136,488. VIKING RIVER CRUISES S.A., L-2017 LUXEMBOURG, LUXEMBOURG, FILED 9-23-2010.



OWNER OF U.S. REG. NOS. 2,697,106, 2,881,355 AND OTHERS.

NO CLAIM IS MADE TO THE EXCLUSIVE RIGHT TO USE "RIVER CRUISES", APART FROM THE MARK AS SHOWN.

THE MARK CONSISTS OF A VIKING-STYLE SHIP CENTERED ABOVE THE WORD "VIKING" AND THE WORDS "RIVER CRUISES" CENTERED BELOW THE WORD "VIKING".

FOR TRANSPORT OF PASSENGERS AND OF GOODS; BOAT CRUISE SERVICES; CRUISE SHIP SERVICES; TRAVEL AGENCY SERVICES, NAMELY, MAKING RESERVATIONS AND TAKING BOOKINGS FOR TRANSPORTATION OF PASSENGERS; TOUR OPERATING SERVICES; ARRANGING OF CRUISES; RESERVATION SERVICES FOR TRANSPORTATION; CRUISE AND CRUISE SHIP RESERVATION SERVICES; ORGANIZATION OF EXCURSIONS; PROVISION OF INFORMATION AND ADVICE RELATING TO ALL THE AFORESAID SERVICES (U.S. CLS. 100 AND 105).

FIRST USE 9-1-1997; IN COMMERCE 5-0-1998.

JASON TURNER, EXAMINING ATTORNEY

SN 85-151,300. ANDREW HESS, NORCROSS, GA. FILED 10-13-2010.



THE COLOR(S) REFLEX BLUE AND GREEN PANTONE 363 IS/ARE CLAIMED AS A FEATURE OF THE MARK.

THE MARK CONSISTS OF THE WORD "AMNISOS" IN REFLEX BLUE WITH THE LETTER "O" FORMED BY A YIN-YANG SYMBOL WHICH HAS THE TOP HALF IN GREEN PANTONE 363 AND THE BOTTOM HALF IN REFLEX BLUE.

FOR WATER DISTRIBUTION AND SUPPLY (U.S. CLS. 100 AND 105).

FIRST USE 4-16-2010; IN COMMERCE 4-20-2010.

JOHN WILKE, EXAMINING ATTORNEY

**CLASS 39—(Continued).**

SN 85-175,538. MONTAGUE, WILLIAM, ATLANTA, GA. FILED 11-12-2010.

LiMaxi

THE MARK CONSISTS OF STANDARD CHARACTERS WITHOUT CLAIM TO ANY PARTICULAR FONT, STYLE, SIZE, OR COLOR.  
FOR LIMOUSINE SERVICES (U.S. CLS. 100 AND 105).  
FIRST USE 5-1-2006; IN COMMERCE 9-1-2010.  
SOPHIA S. KIM, EXAMINING ATTORNEY

**CLASS 39—(Continued).**

SN 85-181,138. EXPLORERS 3 ADVENTURES, DBA EVER-GREEN ESCAPES, SEATTLE, WA. FILED 11-19-2010.

ActiVino!

THE MARK CONSISTS OF STANDARD CHARACTERS WITHOUT CLAIM TO ANY PARTICULAR FONT, STYLE, SIZE, OR COLOR.  
FOR TOUR CONDUCTING OR ESCORTING (U.S. CLS. 100 AND 105).  
FIRST USE 3-1-2009; IN COMMERCE 3-1-2009.  
KAREN BRACEY, EXAMINING ATTORNEY

SN 85-177,430. SKYLAND CORPORATION, VENICE, CA. FILED 11-16-2010.

SKYLAND

THE MARK CONSISTS OF STANDARD CHARACTERS WITHOUT CLAIM TO ANY PARTICULAR FONT, STYLE, SIZE, OR COLOR.  
FOR TRANSPORTATION OF GOODS (U.S. CLS. 100 AND 105).  
MATTHEW EINSTEIN, EXAMINING ATTORNEY

**CLASS 40—MATERIAL TREATMENT**

SN 77-458,256. EASYKEYS.COM, INC., CHARLOTTE, NC. FILED 4-25-2008.

easykeys.com

SN 85-178,470. MARK PONDOFF, FOUNTAIN VALLEY, CA. FILED 11-16-2010.

PARTYLOUNGE

THE MARK CONSISTS OF STANDARD CHARACTERS WITHOUT CLAIM TO ANY PARTICULAR FONT, STYLE, SIZE, OR COLOR.  
SEC. 2(F).  
FOR TRANSPORT OF PASSENGERS AND/OR GOODS BY LIMOUSINES, BUSES AND VANS (U.S. CLS. 100 AND 105).  
FIRST USE 1-1-2004; IN COMMERCE 1-1-2004.  
CAROLYN CATALDO, EXAMINING ATTORNEY

THE MARK CONSISTS OF STANDARD CHARACTERS WITHOUT CLAIM TO ANY PARTICULAR FONT, STYLE, SIZE, OR COLOR.  
NO CLAIM IS MADE TO THE EXCLUSIVE RIGHT TO USE ".COM", APART FROM THE MARK AS SHOWN.  
FOR LOCKSMITHING, NAMELY, CUSTOM FABRICATION OF REPLACEMENT KEYS FOR OFFICE FURNITURE ON AN EXPEDITED BASIS VIA THE INTERNET (U.S. CLS. 100, 103 AND 106).  
FIRST USE 10-22-2007; IN COMMERCE 10-22-2007.  
STEVEN JACKSON, EXAMINING ATTORNEY

**CLASS 40—(Continued).**

SN 77-458,289. EASYKEYS.COM, INC., CHARLOTTE, NC.  
FILED 4-25-2008.



NO CLAIM IS MADE TO THE EXCLUSIVE RIGHT TO USE ".COM", APART FROM THE MARK AS SHOWN.

THE MARK CONSISTS OF A COMPUTER MONITOR AND KEYBOARD WITH A HAND COMING OUT OF THE COMPUTER MONITOR. THE HAND EXTENDING FROM THE COMPUTER MONITOR IS HOLDING A KEY. THE WORDOMG "EASYKEYS.COM" IS BELOW THE DESIGN ELEMENT.

FOR LOCKSMITHING, NAMELY, CUSTOM FABRICATION OF REPLACEMENT KEYS FOR OFFICE FURNITURE ON AN EXPEDITED BASIS VIA THE INTERNET (U.S. CLS. 100, 103 AND 106).

FIRST USE 10-22-2007; IN COMMERCE 10-22-2007.  
STEVEN JACKSON, EXAMINING ATTORNEY

SN 77-710,703. BIOGREEN SOLUTIONS LLC, FERNDALE, MI. FILED 4-9-2009.



NO CLAIM IS MADE TO THE EXCLUSIVE RIGHT TO USE "SOLUTIONS", APART FROM THE MARK AS SHOWN.

THE STIPPLING IS FOR SHADING PURPOSES ONLY.  
THE MARK CONSISTS OF THE WORDS "BIOGREEN" (ALL LOWER CASE) AND "SOLUTIONS" (ALL UPPER CASE) THAT SIT BELOW A LEAF THAT EXTENDS FROM THE "I" IN "BIOGREEN".

FOR BACTERIAL, VIRAL AND MOLD DECONTAMINATION SERVICES (U.S. CLS. 100, 103 AND 106).  
FIRST USE 11-11-2008; IN COMMERCE 11-11-2008.  
SUZANNE BLANE, EXAMINING ATTORNEY

**CLASS 40—(Continued).**

SN 77-793,905. EARTHRENEW, INC., CALGARY, AB, CA.  
FILED 7-30-2009.

**SOILRENEW**

THE MARK CONSISTS OF STANDARD CHARACTERS WITHOUT CLAIM TO ANY PARTICULAR FONT, STYLE, SIZE, OR COLOR.

OWNER OF U.S. REG. NOS. 3,411,052, 3,548,840 AND 3,577,837.

FOR CONSULTATION WITH REGARD TO TREATMENT OF WASTE MATERIALS (U.S. CLS. 100, 103 AND 106).

BRIDGETT SMITH, EXAMINING ATTORNEY

SN 77-858,420. WALCZYK JR., ROBERT J., GREEN BAY, WI.  
FILED 10-27-2009.

**FOREVER FRIENDS**

THE MARK CONSISTS OF STANDARD CHARACTERS WITHOUT CLAIM TO ANY PARTICULAR FONT, STYLE, SIZE, OR COLOR.

FOR PET CREMATION SERVICES (U.S. CLS. 100, 103 AND 106).

FIRST USE 10-23-2002; IN COMMERCE 10-23-2002.  
ESTHER A. BORSUK, EXAMINING ATTORNEY

SN 77-909,449. TIME'S UP, INC., LAS VEGAS, NV. FILED 1-11-2010.

**SHOWCASE YOUR BRAND,  
NOT JUST YOUR LOGO**

THE MARK CONSISTS OF STANDARD CHARACTERS WITHOUT CLAIM TO ANY PARTICULAR FONT, STYLE, SIZE, OR COLOR.

FOR PREPARING CUSTOMIZED PROMOTIONAL MERCHANDISING MATERIALS, NAMELY, CUSTOMIZED IMPRINTING OF COMPANY NAMES, LOGOS, AND IMAGES ON PROMOTIONAL MERCHANDISE FOR OTHERS (U.S. CLS. 100, 103 AND 106).

FIRST USE 12-15-2009; IN COMMERCE 12-15-2009.  
MARILYN IZZI, EXAMINING ATTORNEY



**CLASS 40—(Continued).**

SN 77-909,462. TIME'S UP, INC., LAS VEGAS, NV. FILED 1-11-2010.

**SHOWCASE THE BRAND, NOT  
JUST THE LOGO**

THE MARK CONSISTS OF STANDARD CHARACTERS WITHOUT CLAIM TO ANY PARTICULAR FONT, STYLE, SIZE, OR COLOR.

FOR PREPARING CUSTOMIZED PROMOTIONAL MERCHANDISING MATERIALS, NAMELY, CUSTOMIZED IMPRINTING OF COMPANY NAMES, LOGOS, AND IMAGES ON PROMOTIONAL MERCHANDISE FOR OTHERS (U.S. CLS. 100, 103 AND 106).

FIRST USE 12-15-2009; IN COMMERCE 12-15-2009.  
MARILYN IZZI, EXAMINING ATTORNEY

**CLASS 40—(Continued).**

SN 85-035,339. HEADWATERS WIND FARM LLC, HOUSTON, TX. FILED 5-11-2010.



SN 85-013,307. INFECTION PREVENTION TECHNOLOGIES, LLC, AUBURN HILLS, MI. FILED 4-13-2010.

# Steri-Trak

THE MARK CONSISTS OF STANDARD CHARACTERS WITHOUT CLAIM TO ANY PARTICULAR FONT, STYLE, SIZE, OR COLOR.

FOR STERILIZATION SERVICES, NAMELY, STERILIZATION OF ROOMS (U.S. CLS. 100, 103 AND 106).

COLLEEN DOMBROW, EXAMINING ATTORNEY

NO CLAIM IS MADE TO THE EXCLUSIVE RIGHT TO USE "WIND FARM", APART FROM THE MARK AS SHOWN.

THE MARK CONSISTS OF ONE WIND TURBINE ABOVE THREE RIVERS FLOWING DOWNWARD TOWARDS THE WORDS "HEADWATERS WIND FARM".

FOR GENERATION OF ENERGY BY WIND POWER (U.S. CLS. 100, 103 AND 106).

DAVID TOOLEY, EXAMINING ATTORNEY

SN 85-018,406. KLEEN TEST PRODUCTS CORPORATION, PORT WASHINGTON, WI. FILED 4-20-2010.

**YOUR BRANDS, IN TRUSTED  
HANDS**

THE MARK CONSISTS OF STANDARD CHARACTERS WITHOUT CLAIM TO ANY PARTICULAR FONT, STYLE, SIZE, OR COLOR.

FOR CONTRACT MANUFACTURING IN THE FIELD OF DRYER SHEETS, CLEANING WIPES, LIQUID FILLING, DIE CUTTING, LAMINATING, PACKAGING, FILTERS, CONTAINER FILLING, AND CONFECTIONARY PRODUCTS (U.S. CLS. 100, 103 AND 106).

FIRST USE 3-1-2010; IN COMMERCE 3-1-2010.  
BRENDAN MCCAULEY, EXAMINING ATTORNEY

SN 85-061,871. E.ON CLIMATE & RENEWABLES NORTH AMERICA, LLC, AUSTIN, TX. FILED 6-14-2010.

# Champion Wind Farm

THE MARK CONSISTS OF STANDARD CHARACTERS WITHOUT CLAIM TO ANY PARTICULAR FONT, STYLE, SIZE, OR COLOR.

NO CLAIM IS MADE TO THE EXCLUSIVE RIGHT TO USE "WIND FARM", APART FROM THE MARK AS SHOWN.

FOR PRODUCTION OF WIND ENERGY (U.S. CLS. 100, 103 AND 106).

FIRST USE 1-5-2007; IN COMMERCE 1-28-2008.  
LINDA M. KING, EXAMINING ATTORNEY

**CLASS 40—(Continued).**

SN 85-070,830. SEAN R TIMBERLAKE, SAN FRANCISCO, CA. FILED 6-24-2010.

## Punk Domestics

THE MARK CONSISTS OF STANDARD CHARACTERS WITHOUT CLAIM TO ANY PARTICULAR FONT, STYLE, SIZE, OR COLOR.

NO CLAIM IS MADE TO THE EXCLUSIVE RIGHT TO USE "DOMESTICS", APART FROM THE MARK AS SHOWN.

FOR PROVIDING A WEB SITE FEATURING PHOTOGRAPHIC AND PROSE PRESENTATIONS FEATURING HOME-BASED FOOD PRESERVATION, CHEESE-MAKING, MEAT CURING, AND FOOD AND DRINK FERMENTING AND DISTILLING; ENTERTAINMENT SERVICES, NAMELY, PROVIDING A WEB SITE FEATURING PHOTOGRAPHIC, AUDIO, VIDEO AND PROSE PRESENTATIONS FEATURING HOME-BASED FOOD PRESERVATION, CHEESE-MAKING, MEAT CURING, AND FOOD AND DRINK FERMENTING AND DISTILLING; ENTERTAINMENT SERVICES, NAMELY, PROVIDING A WEB SITE FEATURING PHOTOGRAPHIC, VIDEO AND PROSE PRESENTATIONS FEATURING HOME-BASED FOOD PRESERVATION, CHEESE-MAKING, MEAT CURING, AND FOOD AND DRINK FERMENTING AND DISTILLING; PROVIDING A WEBSITE FOR ENTERTAINMENT PURPOSES WHERE USERS CAN VIEW AND POST IMAGES, VIDEO AND PROSE FEATURING HOME-BASED FOOD PRESERVATION, CHEESE-MAKING, MEAT CURING, AND FOOD AND DRINK FERMENTING AND DISTILL (U.S. CLS. 100, 103 AND 106).

FIRST USE 4-1-2010; IN COMMERCE 4-1-2010.  
TRACY CROSS, EXAMINING ATTORNEY

**CLASS 40—(Continued).**

SN 85-112,880. JAY BANKS, DBA JAY BANKS PRODUCTIONS, INC., SPRING HILL, TN. FILED 8-21-2010.



THE NAME IDENTIFIES A PARTICULAR LIVING INDIVIDUAL WHOSE CONSENT IS OF RECORD.

THE COLOR(S) RED, CARDINAL, SAGE, PALE YELLOW, BLACK IS/ARE CLAIMED AS A FEATURE OF THE MARK.

THE MARK CONSISTS OF THE WORDING "CRAZY J'S" IN STYLIZED FORM. THE WORD "CRAZY" IS IN PALE YELLOW, "J'S" IS IN RED, BLACK AND CARDINAL, AND THE BACKGROUND SHAPE IS SAGE.

FOR CUSTOMIZED IMPRINTING OF COMPANY NAMES AND LOGOS ON THE GOODS OF OTHERS, NAMELY, ON PROMOTIONAL MERCHANDISE, APPAREL AND CORPORATE GIFTS; CUSTOMIZED PRINTING OF COMPANY NAMES AND LOGOS FOR PROMOTIONAL AND ADVERTISING PURPOSES ON THE GOODS OF OTHERS (U.S. CLS. 100, 103 AND 106).

FIRST USE 4-1-2010; IN COMMERCE 4-1-2010.  
JOHN E. MICHOS, EXAMINING ATTORNEY

SN 85-131,541. NEWMARKET IMPRESSIONS, LLC, BEVERLY HILLS, CA. FILED 9-16-2010.

## NewMarket Impressions

SN 85-106,632. INNOVISION, INC, MEMPHIS, TN. FILED 8-12-2010.

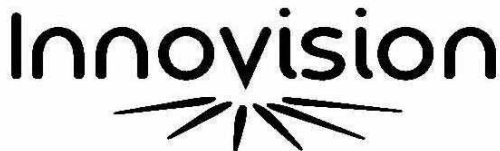

THE MARK CONSISTS OF A SUNBURST COMING FROM UNDER THE TEXT "INNOVISION", CENTERED UNDER THE "V".

FOR MANUFACTURING SERVICES FOR OTHERS IN THE FIELD OF DENTAL AND MEDICAL IMPLANTS (U.S. CLS. 100, 103 AND 106).

FIRST USE 1-1-1994; IN COMMERCE 1-1-1994.  
MATTHEW PAPPAS, EXAMINING ATTORNEY

THE MARK CONSISTS OF STANDARD CHARACTERS WITHOUT CLAIM TO ANY PARTICULAR FONT, STYLE, SIZE, OR COLOR.

NO CLAIM IS MADE TO THE EXCLUSIVE RIGHT TO USE "IMPRESSIONS", APART FROM THE MARK AS SHOWN.

FOR CUSTOMIZED PRINTING OR ETCHING FOR OTHERS, NAMELY, PRINTING OR ETCHING DATE MARKINGS AND ADVERTISING ON THE EGGS OF OTHERS (U.S. CLS. 100, 103 AND 106).

FIRST USE 9-0-2010; IN COMMERCE 9-0-2010.  
JENNY PARK, EXAMINING ATTORNEY

**CLASS 40—(Continued).**

SN 85-146,696. NEWPORT CLASSIC BOATS, COSTA MESA, CA. FILED 10-6-2010.

**Newport Classic Boats by  
Jack Cole**

THE MARK CONSISTS OF STANDARD CHARACTERS WITHOUT CLAIM TO ANY PARTICULAR FONT, STYLE, SIZE, OR COLOR.

NO CLAIM IS MADE TO THE EXCLUSIVE RIGHT TO USE "NEWPORT CLASSIC BOATS", APART FROM THE MARK AS SHOWN.

THE NAME(S), PORTRAIT(S), AND/OR SIGNATURE(S) SHOWN IN THE MARK IDENTIFIES "JACK COLE", WHOSE CONSENT(S) TO REGISTER IS MADE OF RECORD.

FOR CUSTOM MANUFACTURE OF BOATS (U.S. CLS. 100, 103 AND 106).

FIRST USE 3-4-2007; IN COMMERCE 3-4-2007.  
FRANK LATTUCA, EXAMINING ATTORNEY

**CLASS 40—(Continued).**

SN 85-149,828. JOHN MANEELY COMPANY, BEACHWOOD, OH. FILED 10-11-2010.



NO CLAIM IS MADE TO THE EXCLUSIVE RIGHT TO USE "TUBE", APART FROM THE MARK AS SHOWN.

THE MARK CONSISTS OF A STYLIZED DRAWING OF A SHEAF OF WHEAT, WITH THE WORDING "WHEATLAND TUBE".

FOR CUSTOM MANUFACTURE OF GENERAL PRODUCT LINES IN THE FIELD OF PIPE AND TUBING, CONTINUOUS WELD AND ELECTRIC WELD TUBING PRODUCTS, ELECTRIC CONDUIT, COUPLINGS AND THREADED FITTINGS, STEEL PIPE, GALVANIZED MECHANICAL TUBING, AND METAL FENCE FRAMEWORK AND TUBING (U.S. CLS. 100, 103 AND 106).

FIRST USE 0-0-1931; IN COMMERCE 0-0-1931.  
MARK PILARO, EXAMINING ATTORNEY

SN 85-150,430. TOO COOL T-SHIRT QUILTS INTERNATIONAL, LLC, OLIVET, MI. FILED 10-12-2010.

**TOO COOL T-SHIRT QUILTS**

THE MARK CONSISTS OF STANDARD CHARACTERS WITHOUT CLAIM TO ANY PARTICULAR FONT, STYLE, SIZE, OR COLOR.

NO CLAIM IS MADE TO THE EXCLUSIVE RIGHT TO USE "T-SHIRT QUILTS", APART FROM THE MARK AS SHOWN.

FOR CUSTOM QUILTING SERVICES (U.S. CLS. 100, 103 AND 106).

FIRST USE 7-31-2003; IN COMMERCE 7-31-2003.  
MICHAEL WIENER, EXAMINING ATTORNEY

SN 85-149,778. JOHN MANEELY COMPANY, BEACHWOOD, OH. FILED 10-11-2010.



THE MARK CONSISTS OF A HEXAGON COMPOSED OF NINETEEN SOLID CIRCLES.

FOR CUSTOM MANUFACTURE OF GENERAL PRODUCT LINES IN THE FIELD OF STEEL PIPE AND TUBING, STRUCTURAL STEEL TUBING, HOLLOW STRUCTURAL SECTIONS MADE OF STEEL, STEEL DISTRIBUTION POLES, CONTINUOUS WELD AND ELECTRIC WELD TUBING PRODUCTS, ELECTRIC CONDUIT, COUPLINGS AND FITTINGS, STEEL PIPE, GALVANIZED MECHANICAL TUBING, AND METAL FENCE FRAMEWORK (U.S. CLS. 100, 103 AND 106).

FIRST USE 10-8-2010; IN COMMERCE 10-8-2010.  
MARK PILARO, EXAMINING ATTORNEY

SN 85-150,766. JME GRAPHICS, INC., FARMINGTON, CT. FILED 10-12-2010.

**JME GRAPHICS**

THE MARK CONSISTS OF STANDARD CHARACTERS WITHOUT CLAIM TO ANY PARTICULAR FONT, STYLE, SIZE, OR COLOR.

NO CLAIM IS MADE TO THE EXCLUSIVE RIGHT TO USE "GRAPHICS", APART FROM THE MARK AS SHOWN.

FOR SILK SCREEN PRINTING (U.S. CLS. 100, 103 AND 106).

JAMES GRIFFIN, EXAMINING ATTORNEY

**CLASS 40—(Continued).**

SN 85-151,045. JSN PACKAGING PRODUCTS, INC., IRVINE, CA. FILED 10-12-2010.

# JSN

THE MARK CONSISTS OF STANDARD CHARACTERS WITHOUT CLAIM TO ANY PARTICULAR FONT, STYLE, SIZE, OR COLOR.

FOR CUSTOM MANUFACTURE OF PLASTIC INJECTED MOLDED PRODUCTS (U.S. CLS. 100, 103 AND 106).

FIRST USE 1-1-1984; IN COMMERCE 1-1-1984.  
ELLEN B. AWRICH, EXAMINING ATTORNEY

---

SN 85-152,702. AURORA PHARMACEUTICAL, LLC, NORTHFIELD, MN. FILED 10-14-2010.

## AURORA PHARMACEUTICAL

THE MARK CONSISTS OF STANDARD CHARACTERS WITHOUT CLAIM TO ANY PARTICULAR FONT, STYLE, SIZE, OR COLOR.

NO CLAIM IS MADE TO THE EXCLUSIVE RIGHT TO USE "PHARMACEUTICAL", APART FROM THE MARK AS SHOWN.

FOR MANUFACTURING SERVICES FOR OTHERS OF PHARMACEUTICAL PRODUCTS AND COMPOUNDS FOR HUMANS AND ANIMALS (U.S. CLS. 100, 103 AND 106).

FIRST USE 6-0-2009; IN COMMERCE 6-0-2009.  
MELISSA VALLILLO, EXAMINING ATTORNEY

---

SN 85-152,741. AURORA PHARMACEUTICAL, LLC, NORTHFIELD, MN. FILED 10-14-2010.



NO CLAIM IS MADE TO THE EXCLUSIVE RIGHT TO USE "PHARMACEUTICAL", APART FROM THE MARK AS SHOWN.

THE MARK CONSISTS OF STYLIZED WORD "AURORA" ENCAPSULATED WITH AN OVAL DESIGN BEGINNING ABOVE THE LETTER "O" AND ENDING UNDERNEATH THE SECOND LETTER "A" UNDER WHICH IS THE STYLIZED WORD "PHARMACEUTICAL".

FOR MANUFACTURING SERVICES FOR OTHERS OF PHARMACEUTICAL PRODUCTS AND COMPOUNDS FOR HUMANS AND ANIMALS (U.S. CLS. 100, 103 AND 106).

FIRST USE 6-0-2009; IN COMMERCE 6-0-2009.  
MELISSA VALLILLO, EXAMINING ATTORNEY

**CLASS 40—(Continued).**

SN 85-153,485. GEMACO INC., BLUE SPRINGS, MO. FILED 10-15-2010.

# GEMTECH

THE MARK CONSISTS OF STANDARD CHARACTERS WITHOUT CLAIM TO ANY PARTICULAR FONT, STYLE, SIZE, OR COLOR.

FOR CUSTOM MANUFACTURE OF PLASTIC COMPONENT PARTS FOR OTHERS AND PLASTIC INJECTION MOLDING SERVICES, BUT NOT INCLUDING NETWORK CARDS, NETWORK HUBS, NETWORK ROUTERS, NETWORK RESIDENTIAL GATEWAYS, NETWORK BRIDGES, HIGH-WAVE ANTENNAS, COMMUNICATION SERVERS, COMMUNICATION APPARATUS, COMPUTER INTERFACE ELECTRIC DRIVING APPARATUS, ELECTRIC CAMERAS, VIDEO CONFERENCE EQUIPMENT, VIDEO PHONES, RADIO TRANSMITTER-RECEIVERS, RADIO RECEIVERS, RADIO TRANSMITTERS, MICROPHONES, HIGH-WAVE BOOSTERS, VIDEO TRANSMITTER-RECEIVERS, SIGNAL BOOSTERS, SIGNAL TRANSDUCERS, INFRARED EXAMINED SENSORS, SATELLITE ANTENNAS, VIDEO COMMUNICATION DEVICES, CONVERSION DEMODULATORS, DRAWING MACHINE CONTROLLER CARDS, COMPUTER SCANNERS (U.S. CLS. 100, 103 AND 106).  
JASON BLAIR, EXAMINING ATTORNEY

---

SN 85-153,495. GEMACO INC., BLUE SPRINGS, MO. FILED 10-15-2010.



THE MARK CONSISTS OF THE WORD "GEMTECH" IN STYLIZED FORM, WITH THE LETTER "G" INSIDE A CIRCLE, WITH AN OVERLAID SHADOW EFFECT.

FOR CUSTOM MANUFACTURE OF PLASTIC COMPONENT PARTS FOR OTHERS AND PLASTIC INJECTION MOLDING SERVICES, BUT NOT INCLUDING NETWORK CARDS, NETWORK HUBS, NETWORK ROUTERS, NETWORK RESIDENTIAL GATEWAYS, NETWORK BRIDGES, HIGH-WAVE ANTENNAS, COMMUNICATION SERVERS, COMMUNICATION APPARATUS, COMPUTER INTERFACE ELECTRIC DRIVING APPARATUS, ELECTRIC CAMERAS, VIDEO CONFERENCE EQUIPMENT, VIDEO PHONES, RADIO TRANSMITTER-RECEIVERS, RADIO RECEIVERS, RADIO TRANSMITTERS, MICROPHONES, HIGH-WAVE BOOSTERS, VIDEO TRANSMITTER-RECEIVERS, SIGNAL BOOSTERS, SIGNAL TRANSDUCERS, INFRARED EXAMINED SENSORS, SATELLITE ANTENNAS, VIDEO COMMUNICATION DEVICES, CONVERSION DEMODULATORS, DRAWING MACHINE CONTROLLER CARDS, COMPUTER SCANNERS (U.S. CLS. 100, 103 AND 106).  
JASON BLAIR, EXAMINING ATTORNEY

**CLASS 40—(Continued).**

SN 85-156,162. NAPHTAL, WAYNE, LOS ANGELES, CA. FILED 10-19-2010.

**LIGHT TOUCH**

THE MARK CONSISTS OF STANDARD CHARACTERS WITHOUT CLAIM TO ANY PARTICULAR FONT, STYLE, SIZE, OR COLOR.

FOR CONVERSION OF 2D VIDEOS AND PHOTOGRAPHS TO 3D (U.S. CLS. 100, 103 AND 106). ELLEN B. AWRICH, EXAMINING ATTORNEY

SN 85-156,484. RED WOLF REFINING CORPORATION, PINEHURST, NC. FILED 10-19-2010.

**Red Wolf Refining**

THE MARK CONSISTS OF STANDARD CHARACTERS WITHOUT CLAIM TO ANY PARTICULAR FONT, STYLE, SIZE, OR COLOR.

NO CLAIM IS MADE TO THE EXCLUSIVE RIGHT TO USE "REFINING", APART FROM THE MARK AS SHOWN. FOR FUEL REFINING (U.S. CLS. 100, 103 AND 106). COLLEEN DOMBROW, EXAMINING ATTORNEY

SN 85-158,964. CONSOLIDATED WASTE MANAGEMENT, LLC, GLASTONBURY, CT. FILED 10-22-2010.



NO CLAIM IS MADE TO THE EXCLUSIVE RIGHT TO USE "CONSOLIDATED WASTE MANAGEMENT LLC.", APART FROM THE MARK AS SHOWN.

THE MARK CONSISTS OF THE LETTERS "CWM", ALL UPPER CASE IN A STYLIZED FORMAT, THE WORD "CONSOLIDATED", IN UPPER CASE BELOW "CWM" AND THE WORDS "WASTE MANAGEMENT" IN LOWER CASE AND "LLC." BOTH BELOW THE WORD "CONSOLIDATED".

FOR WASTE MANAGEMENT SERVICES (U.S. CLS. 100, 103 AND 106). KATHERINE E. HALMEN, EXAMINING ATTORNEY

**CLASS 40—(Continued).**

SN 85-163,247. MOORE, JARED, LEHI, UT. FILED 10-28-2010.



NO CLAIM IS MADE TO THE EXCLUSIVE RIGHT TO USE "PRECISION FIT", APART FROM THE MARK AS SHOWN.

THE COLOR(S) DARK BLUE, LIGHT BLUE, AND WHITE IS/ARE CLAIMED AS A FEATURE OF THE MARK.

THE MARK CONSISTS OF THE WORDS "PRECISION FIT" WRITTEN IN DARK BLUE COLOR, SEPARATED BY A LIGHT AND DARK BLUE COLORED THREE DIMENSIONAL TRIANGLE. THE COLOR WHITE APPEARS AS HIGHLIGHTING ON THE TRIANGLE AND IN THE BACKGROUND.

FOR DENTAL TECHNICIAN SERVICES (U.S. CLS. 100, 103 AND 106).

FIRST USE 8-3-2010; IN COMMERCE 9-1-2010. KIM MONINGHOFF, EXAMINING ATTORNEY

SN 85-169,936. RECYCLING RULES, INC., ATLANTA, GA. FILED 11-5-2010.

**RECYCLING RULES**

THE MARK CONSISTS OF STANDARD CHARACTERS WITHOUT CLAIM TO ANY PARTICULAR FONT, STYLE, SIZE, OR COLOR.

NO CLAIM IS MADE TO THE EXCLUSIVE RIGHT TO USE "RECYCLING", APART FROM THE MARK AS SHOWN.

FOR CONSULTING SERVICES, NAMELY, PROVIDING INFORMATION AND RESOURCES TO CONSUMERS REGARDING RECYCLING (U.S. CLS. 100, 103 AND 106).

KEVON CHISOLM, EXAMINING ATTORNEY

SN 85-170,725. M. J. LATHERN CO., INC, WACO, TX. FILED 11-5-2010.

**METAL WORKS 4 U**

THE MARK CONSISTS OF STANDARD CHARACTERS WITHOUT CLAIM TO ANY PARTICULAR FONT, STYLE, SIZE, OR COLOR.

NO CLAIM IS MADE TO THE EXCLUSIVE RIGHT TO USE "METAL WORKS", APART FROM THE MARK AS SHOWN.

FOR METAL FABRICATION AND FINISHING SERVICES (U.S. CLS. 100, 103 AND 106).

VERNA BETH RIRIE, EXAMINING ATTORNEY

**CLASS 40—(Continued).**

SN 85-177,341. VALIDUS GROUP INC, SOUTH WHITLEY, IN. FILED 11-15-2010.

## Squirrel Daddy

THE MARK CONSISTS OF STANDARD CHARACTERS WITHOUT CLAIM TO ANY PARTICULAR FONT, STYLE, SIZE, OR COLOR.

FOR WOODWORKING (U.S. CLS. 100, 103 AND 106).  
RONALD MCMORROW, EXAMINING ATTORNEY

---

SN 85-177,867. OPSEC SECURITY GROUP, INC., DENVER, CO. FILED 11-16-2010.

## SecurMET

THE MARK CONSISTS OF STANDARD CHARACTERS WITHOUT CLAIM TO ANY PARTICULAR FONT, STYLE, SIZE, OR COLOR.

FOR TREATMENT OF MATERIALS, NAMELY, AFFIXING AND EMBEDDING PRODUCT AUTHENTICATION SECURITY DEVICES COMPRISING METAL SECURITY FEATURES IN A WIDE VARIETY OF PRODUCTS AND DOCUMENTS TO PROTECT AGAINST COUNTERFEITING, TAMPERING, AND DIVERSION, AND TO ENSURE THE INTEGRITY OF GENUINE PRODUCTS AND DOCUMENTS (U.S. CLS. 100, 103 AND 106).

FIRST USE 8-29-2010; IN COMMERCE 8-29-2010.  
CHRISTINE MARTIN, EXAMINING ATTORNEY

---

SN 85-177,906. OPSEC SECURITY GROUP, INC., DENVER, CO. FILED 11-16-2010.

## SecurMAX

THE MARK CONSISTS OF STANDARD CHARACTERS WITHOUT CLAIM TO ANY PARTICULAR FONT, STYLE, SIZE, OR COLOR.

FOR TREATMENT OF MATERIALS, NAMELY, AFFIXING AND EMBEDDING PRODUCT AUTHENTICATION SECURITY DEVICES COMPRISING LIQUID CRYSTAL MATERIALS IN A WIDE VARIETY OF PRODUCTS AND DOCUMENTS TO PROTECT AGAINST COUNTERFEITING, TAMPERING, AND DIVERSION, AND TO ENSURE THE INTEGRITY OF GENUINE PRODUCTS AND DOCUMENTS (U.S. CLS. 100, 103 AND 106).

FIRST USE 10-8-2007; IN COMMERCE 10-8-2007.  
CHRISTINE MARTIN, EXAMINING ATTORNEY

**CLASS 40—(Continued).**

SN 85-180,430. LATICO TRADING CORP., DENVILLE, NJ. FILED 11-18-2010.

## WE'VE GOT WHAT SHE WANTS

THE MARK CONSISTS OF STANDARD CHARACTERS WITHOUT CLAIM TO ANY PARTICULAR FONT, STYLE, SIZE, OR COLOR.

FOR MANUFACTURE OF LEATHER PRODUCTS TO THE ORDER AND/OR SPECIFICATION OF OTHERS; CONTRACT MANUFACTURING IN THE FIELD OF LEATHER PRODUCTS; MANUFACTURING SERVICES FOR OTHERS IN THE FIELD OF LEATHER PRODUCTS; WORKING OF LEATHER (U.S. CLS. 100, 103 AND 106).  
FIRST USE 10-15-2009; IN COMMERCE 10-15-2009.

JAY FLOWERS, EXAMINING ATTORNEY

**CLASS 41—EDUCATION AND ENTERTAINMENT**

SN 76-701,964. KIDS WEALTH INTERNATIONAL CLUB, INC., NAPERVILLE, IL. FILED 3-8-2010.

## KWIC

THE MARK CONSISTS OF STANDARD CHARACTERS WITHOUT CLAIM TO ANY PARTICULAR FONT, STYLE, SIZE, OR COLOR.

FOR EDUCATIONAL SERVICES, NAMELY, COACHING, CONDUCTING CAMPS, CLASSES, SEMINARS, CONFERENCES AND WORKSHOPS IN THE FIELD OF FINANCIAL LITERACY EDUCATION, BUSINESS BUILDING, ENTREPRENEURSHIP AND WEALTH CREATION, INCLUDING THE DISTRIBUTION OF COURSE MATERIALS AND INSTRUCTIONAL WORKBOOKS IN CONNECTION THEREWITH, FOR KIDS, TEENS AND ADULTS; TRAINING PROGRAMS AND ON-LINE EDUCATIONAL CLUBS WHICH TEACH ADULTS HOW TO TEACH FINANCIAL LITERACY EDUCATION, BUSINESS BUILDING, ENTREPRENEURSHIP AND WEALTH CREATION TO KIDS, TEENS AND ADULTS (U.S. CLS. 100, 101 AND 107).

FIRST USE 2-17-2010; IN COMMERCE 2-17-2010.  
SHAUNIA CARLYLE, EXAMINING ATTORNEY

**CLASS 41—(Continued).**

SN 77-153,161. JOHNSON PUBLISHING COMPANY, INC., CHICAGO, IL. FILED 4-10-2007.

**EBONY BLACK FAMILY REUNION**

THE MARK CONSISTS OF STANDARD CHARACTERS WITHOUT CLAIM TO ANY PARTICULAR FONT, STYLE, SIZE, OR COLOR.

OWNER OF U.S. REG. NOS. 423,815, 3,307,712 AND OTHERS.

NO CLAIM IS MADE TO THE EXCLUSIVE RIGHT TO USE "BLACK FAMILY REUNION", APART FROM THE MARK AS SHOWN.

FOR EDUCATIONAL AND ENTERTAINMENT SERVICES, NAMELY, CONDUCTING CULTURAL PROGRAMS FEATURING LIVE ENTERTAINMENT, FOOD, MUSIC, DANCE AND AUDIOVISUAL PRESENTATIONS, GAMES, SWEEPSTAKES, CONTESTS, AND FOOD PREPARATION DEMONSTRATIONS (U.S. CLS. 100, 101 AND 107).

KRISTIN DAHLING, EXAMINING ATTORNEY

SN 77-437,096. ASK INTERNATIONAL, INC., TORRANCE, CA. FILED 4-1-2008.

**ASK Entertainment**

THE MARK CONSISTS OF STANDARD CHARACTERS WITHOUT CLAIM TO ANY PARTICULAR FONT, STYLE, SIZE, OR COLOR.

NO CLAIM IS MADE TO THE EXCLUSIVE RIGHT TO USE "ENTERTAINMENT", APART FROM THE MARK AS SHOWN.

FOR PRODUCTION OF RADIO AND TELEVISION PROGRAMS (U.S. CLS. 100, 101 AND 107).

ELIZABETH KAJUBI, EXAMINING ATTORNEY

SN 77-509,529. MENDOZA, ANTONIO M, YAKIMA, WA. FILED 6-27-2008.



NO CLAIM IS MADE TO THE EXCLUSIVE RIGHT TO USE "RAZA MICHUACANA", APART FROM THE MARK AS SHOWN.

THE COLOR(S) BLACK, WHITE, GOLD, RED, BROWN, GREEN AND GRAY IS/ARE CLAIMED AS A FEATURE OF THE MARK.

THE COLOR BLACK APPEARS IN THE BACKGROUND OF THE OVAL DESIGN; THE COLOR WHITE APPEARS IN THE HARP DESIGN, IN THE STREAKING LINES EXTENDING ABOVE THE WORDING "RAZA MICHUACANA", AND IN THE OUTLINE OF THE OVAL DESIGN; THE COLOR GOLD APPEARS IN THE OVAL DESIGN AND IN THE HORIZONTAL STRAIGHT LINE BENEATH THE WORD-

**CLASS 41—(Continued).**

ING "RAZA MICHUACANA"; THE COLOR RED APPEARS IN THE WORD "MICHUACANA" AND IN THE STREAKING LINES EXTENDING ABOVE THIS WORD; THE COLOR BROWN APPEARS IN THE SOUNDBOARD OF THE HARP DESIGN AND IN PORTIONS OF THE OVAL DESIGN; THE COLOR GREEN APPEARS IN THE WORD "RAZA" AND IN THE STREAKING LINES EXTENDING ABOVE THIS WORD; AND THE COLOR GRAY APPEARS IN THE HARP DESIGN AND IN THE SHADOW EFFECT OF THE OVAL DESIGN.

THE ENGLISH TRANSLATION OF "RAZA MICHUACANA" IN THE MARK IS "STATE OF MICHUACAN RACE".

FOR ENTERTAINMENT, NAMELY, LIVE PERFORMANCES BY A MUSICAL BAND (U.S. CLS. 100, 101 AND 107).

FIRST USE 3-4-2005; IN COMMERCE 3-4-2005.

ANDREW RHIM, EXAMINING ATTORNEY

SN 77-529,962. LOS SOLITARIOS, NORWALK, MEXICO, FILED 7-23-2008.



THE MARK CONSISTS OF THE WORD "SOLITARIOS" IN STYLIZED FONT.

THE ENGLISH TRANSLATION OF THE WORD "SOLITARIOS" IN THE MARK IS "SOLITARIES".

FOR ENTERTAINMENT SERVICES IN THE NATURE OF LIVE MUSICAL PERFORMANCES (U.S. CLS. 100, 101 AND 107).

FIRST USE 0-0-1965; IN COMMERCE 0-0-1969.

KRISTIN CARLSON, EXAMINING ATTORNEY

SN 77-565,133. MIRAGE RESORTS, INCORPORATED, LAS VEGAS, NV. FILED 9-8-2008.

**CLUB MIRAGE**

THE MARK CONSISTS OF STANDARD CHARACTERS WITHOUT CLAIM TO ANY PARTICULAR FONT, STYLE, SIZE, OR COLOR.

OWNER OF U.S. REG. NOS. 1,710,470, 1,870,053 AND 1,870,054.

NO CLAIM IS MADE TO THE EXCLUSIVE RIGHT TO USE "CLUB", APART FROM THE MARK AS SHOWN.

FOR CASINO SERVICES, NAMELY, OPERATION OF A FREQUENT PLAYERS BONUS PROGRAM (U.S. CLS. 100, 101 AND 107).

ANDREA HACK, EXAMINING ATTORNEY

**CLASS 41—(Continued).**

SN 77-566,037. CSS STUDIOS, LLC, LOS ANGELES, CA. FILED 9-9-2008.



NO CLAIM IS MADE TO THE EXCLUSIVE RIGHT TO USE "STUDIOS", APART FROM THE MARK AS SHOWN. THE MARK CONSISTS OF A STYLIZED DESIGN OF FIVE VERTICAL, ELONGATED OVALS OF DIFFERENT LENGTHS OVER THE STYLIZED WORDING "CSS STUDIOS".

FOR RECORDING STUDIO SERVICES (U.S. CLS. 100, 101 AND 107).

GINA HAYES, EXAMINING ATTORNEY

SN 77-646,744. METRO PHOENIX PARTNERSHIP FOR ARTS AND CULTURE, PHOENIX, AZ. FILED 1-9-2009.

**METRO PHOENIX DNA**

THE MARK CONSISTS OF STANDARD CHARACTERS WITHOUT CLAIM TO ANY PARTICULAR FONT, STYLE, SIZE, OR COLOR.

NO CLAIM IS MADE TO THE EXCLUSIVE RIGHT TO USE "METRO PHOENIX", APART FROM THE MARK AS SHOWN.

FOR PROVIDING A WEB SITE WITH INFORMATION REGARDING AND HIGHLIGHTING ARTS, CULTURE, AND ENTERTAINMENT IN THE GREATER PHOENIX, ARIZONA METROPOLITAN AREA (U.S. CLS. 100, 101 AND 107).

RONALD DELGIZZI, EXAMINING ATTORNEY

SN 77-694,965. GOLD CLUB, INC., SUNNY ISLES BEACH, FL. FILED 3-19-2009.

**BEACH HOUSE CABARET**

THE MARK CONSISTS OF STANDARD CHARACTERS WITHOUT CLAIM TO ANY PARTICULAR FONT, STYLE, SIZE, OR COLOR.

NO CLAIM IS MADE TO THE EXCLUSIVE RIGHT TO USE "CABARET", APART FROM THE MARK AS SHOWN.

FOR ARRANGING AND CONDUCTING ADULT NIGHTCLUB ENTERTAINMENT EVENTS, ARRANGING AND CONDUCTING ADULT NIGHTCLUB PARTIES AND THEATRICAL AND MUSICAL ADULT FLOOR SHOWS PROVIDED AT DISCOTHEQUES AND NIGHTCLUBS, ALL OF WHICH ARE NOT PROVIDED AT HOTELS, RETAIL STORES, CASINOS, BANQUET FACILITIES AND HEALTH SPAS (U.S. CLS. 100, 101 AND 107).

DAVID YONTEF, EXAMINING ATTORNEY

**CLASS 41—(Continued).**

SN 77-706,923. TURDIN, JR., PETER, AKA PETER BRADLEY, BRISTOL, CT. FILED 4-4-2009.

**Trilobite Pictures**

THE MARK CONSISTS OF STANDARD CHARACTERS WITHOUT CLAIM TO ANY PARTICULAR FONT, STYLE, SIZE, OR COLOR.

THE FOLLOWING ARE EXCEPTIONS TO APPLICANT'S RIGHT TO EXCLUSIVE USE OF THE MARK: TRILOBITE, LTD, DOING BUSINESS AT 2811 KERSDALE ROAD, CLEVELAND, OHIO 44124, WHO IS USING THE TRADEMARK, "TRILOBITE" FOR SERVICES CONSISTING OF "AUDIO RECORDING AND PRODUCTION", IN IC 041, AS SHOWN IN U.S. TRADEMARK APPLICATION SERIAL NO. 77/689769 SINCE DECEMBER 31, 1986; AND "VIDEO PRODUCTION SERVICES", IN IC 041, AS SHOWN IN US TRADEMARK APPLICATION SERIAL NO. 77/689792, SINCE DECEMBER 31, 1985 IN A TRADING AREA CONSISTING OF OHIO AND MICHIGAN. THE APPLICANT REQUESTS REGISTRATION OF THE SERVICE MARK, "TRILOBITE PICTURES" IDENTIFIED IN THE UNITED STATES PATENT AND TRADEMARK OFFICE ON THE PRINCIPAL REGISTER ESTABLISHED BY THE ACT OF JULY 5, 1946 (15 U.S.C. SECTION 1051 ET SEQ.) FOR THE AREA COMPRISING THE STATE OF CONNECTICUT AND NEW YORK, NEW YORK.

NO CLAIM IS MADE TO THE EXCLUSIVE RIGHT TO USE "PICTURES", APART FROM THE MARK AS SHOWN. FOR MOTION PICTURE FILM PRODUCTION, AND ANIMATION SERVICES (U.S. CLS. 100, 101 AND 107).

FIRST USE 1-3-2000; IN COMMERCE 1-3-2000.

ODESSA BIBBINS, EXAMINING ATTORNEY

SN 77-801,959. WORLDWIDE GOLF ENTERPRISES INC., SANTA ANA, CA. FILED 8-11-2009.



OWNER OF U.S. REG. NO. 7,780,195.

NO CLAIM IS MADE TO THE EXCLUSIVE RIGHT TO USE "FIT", APART FROM THE MARK AS SHOWN.

THE STIPLING IS A FEATURE OF THE MARK AND DOES NOT INDICATE COLOR. THE STIPLING IS FOR SHADING PURPOSES ONLY.

THE MARK CONSISTS OF THE STYLIZED TEXT "TOTAL FIT PERSONALIZED CUSTOM CLUB FITTING FOR EVERY CLUB IN THE BAG" WITH A GOLF BALL ON THE BACKGROUND WITH GRASS AT THE BOTTOM.

FOR GOLF CLUB SERVICES, NAMELY, A SERVICE TO HELP ASSIST CUSTOMERS IN IDENTIFYING THE CORRECT GOLF CLUBS TO FIT THEIR NEEDS (U.S. CLS. 100, 101 AND 107).

FIRST USE 6-1-2009; IN COMMERCE 6-15-2009.

JACQUELINE A. LAVINE, EXAMINING ATTORNEY



**CLASS 41—(Continued).**

SN 77-844,450. LOS ANGELES FILM SCHOOLS, LLC, HOLLYWOOD, CA. FILED 10-8-2009.

**CLASS 41—(Continued).**

SN 77-849,638. ANA CAMINO HUSS, SCOTTSDALE, AZ. FILED 10-15-2009.

The Mothers

LOS ANGELES FILM UNIVERSITY

THE MARK CONSISTS OF STANDARD CHARACTERS WITHOUT CLAIM TO ANY PARTICULAR FONT, STYLE, SIZE, OR COLOR.

OWNER OF U.S. REG. NOS. 2,460,573 AND 3,390,687.

NO CLAIM IS MADE TO THE EXCLUSIVE RIGHT TO USE "FILM UNIVERSITY", APART FROM THE MARK AS SHOWN.

SEC. 2(F).

FOR PROVIDING AN ON-LINE COMPUTER DATABASE FOR STUDENTS IN THE FIELDS OF INSTRUCTION FOR ENTERTAINMENT PROGRAM DIRECTING, PRODUCING, CINEMATOGRAPHY, EDITING, PRODUCTION DESIGN, SOUND RECORDING, MUSIC RECORDING, SCREEN WRITING AND DIGITAL MEDIA MIXING, ALL IN THE FIELDS OF AUDIOVISUAL MEDIA, MOTION PICTURES AND MUSIC PRODUCTION FOR DIGITAL MEDIA, FILMS AND TELEVISION PROGRAMS; PROVIDING AN ON-LINE COMPUTER DATABASE FOR STUDENTS IN THE FIELDS OF INSTRUCTION OF ART, MUSIC, RADIO, FILM PRODUCTION, VIDEO PRODUCTION, TELEVISION PROGRAMMING PRODUCTION, DIGITAL MEDIA, COMPUTER ANIMATION PRODUCTION, LIVE EVENT PRODUCTION, TEACHER AND INSTRUCTOR CREDENTIALING, ENTERTAINMENT MEDIA DESIGN, CREATIVE WRITING, AND JOURNALISM, ALL FOR INDEPENDENT ARTISTS, FILM MAKERS AND RECORDING ARTISTS; EDUCATIONAL SERVICES, NAMELY, PROVIDING LIVE COURSES OF INSTRUCTION, SEMINARS, CONFERENCES AND WORKSHOPS, ON-LINE AND NON-DOWNLOADABLE PRE-RECORDED COURSES OF INSTRUCTION, SEMINARS, CONFERENCES AND WORKSHOPS, ALL IN THE FIELDS OF ENTERTAINMENT PROGRAM DIRECTING, PRODUCING, CINEMATOGRAPHY, EDITING, PRODUCTION DESIGN, SOUND RECORDING, SCREEN WRITING AND DIGITAL MEDIA MIXING, ALL IN THE FIELDS OF AUDIOVISUAL MEDIA, MOTION PICTURES, DIGITAL PRESENTATIONS FOR FILM, FILMS, TELEVISION PROGRAMS, ART, MUSIC, RADIO, FILM, VIDEO, TELEVISION, DIGITAL MEDIA, WEB DESIGN, COMPUTER ANIMATION, GAME DESIGN, LIVE EVENT PRODUCTION, TEACHER AND INSTRUCTOR CREDENTIALING, GRAPHIC DESIGN, INTERNET MARKETING, MEDIA DESIGN, CREATIVE WRITING, JOURNALISM, ENTERTAINMENT INDUSTRY ACCOUNTING, ENTERTAINMENT INDUSTRY BUDGETING, ARTIST MANAGEMENT AND PRODUCTION MANAGEMENT, ENTERTAINMENT MARKETING, PROMOTION, FUND-RAISING AND ADVERTISING, FOR INDEPENDENT ARTISTS, FILM MAKERS AND RECORDING ARTISTS; MUSIC PRODUCTION, MOTION PICTURE FILM PRODUCTION, PRODUCTION OF VIDEO DISCS, TELEVISION PROGRAMS, DIGITAL ENTERTAINMENT MEDIA PRODUCTION, COMPUTER GAME PRODUCTION, AND COMPUTER ANIMATION PRODUCTION SERVICES (U.S. CLS. 100, 101 AND 107).

CHARLOTTE CORWIN, EXAMINING ATTORNEY

NO CLAIM IS MADE TO THE EXCLUSIVE RIGHT TO USE "MOTHERS", APART FROM THE MARK AS SHOWN. THE MARK CONSISTS OF THE WORDS "THE MOTHERS" WHERE THE "O" IS REPLACED WITH A SOLID HEART.

FOR EDUCATION AND ENTERTAINMENT SERVICES, NAMELY, PRODUCTION AND DISTRIBUTION OF ONGOING TELEVISION PROGRAMS IN THE FIELD OF FAMILY MANAGEMENT AND RELATIONSHIPS; ENTERTAINMENT, NAMELY, A CONTINUING TALK SHOW BROADCAST OVER TELEVISION (U.S. CLS. 100, 101 AND 107).

TRACY WHITTAKER-BROWN, EXAMINING ATTORNEY

SN 77-852,543. SCRIPPS NETWORKS, LLC, KNOXVILLE, TN. FILED 10-20-2009.

HGTV CHALLENGE

THE MARK CONSISTS OF STANDARD CHARACTERS WITHOUT CLAIM TO ANY PARTICULAR FONT, STYLE, SIZE, OR COLOR.

OWNER OF U.S. REG. NOS. 2,205,702, 3,435,671 AND OTHERS.

NO CLAIM IS MADE TO THE EXCLUSIVE RIGHT TO USE "CHALLENGE", APART FROM THE MARK AS SHOWN.

FOR EDUCATIONAL AND ENTERTAINMENT SERVICES, NAMELY, A CONTINUING PROGRAM ABOUT INTERIOR DESIGN AND DECORATING, ACCESSIBLE BY RADIO, TELEVISION, CABLE, FIBER OPTIC NETWORKS, WIRELESS NETWORKS, SATELLITE, AUDIO VIDEO, AND COMPUTER NETWORKS (U.S. CLS. 100, 101 AND 107).

LOURDES AYALA, EXAMINING ATTORNEY

**CLASS 41—(Continued).**

SN 77-872,716. SKYUNION PTE. LTD., 159308, SINGAPORE, FILED 11-14-2009.



THE COLOR(S) GOLD AND RED IS/ARE CLAIMED AS A FEATURE OF THE MARK.

THE MARK CONSISTS OF THE WORDING "TALES OF FANTASY" IN GOLD SUPERIMPOSED OVER A RED DRAGON.

FOR EDUCATIONAL EXAMINATION; ORGANISATION OF SPORTS COMPETITIONS; ORGANIZATION OF EXHIBITIONS FOR CULTURAL OR EDUCATIONAL PURPOSES; PUBLICATION OF BOOKS; PUBLICATION OF ELECTRONIC MAGAZINES; PUBLICATION OF TEXTS, BOOKS, MAGAZINES AND OTHER PRINTED MATTER; PUBLISHING OF ELECTRONIC PUBLICATIONS; SOCIAL CLUB SERVICES, NAMELY, ARRANGING, ORGANIZING, AND HOSTING SOCIAL EVENTS, GET-TOGETHERS, AND PARTIES FOR CLUB MEMBERS (U.S. CLS. 100, 101 AND 107).

REBECCA POVARCHUK, EXAMINING ATTORNEY

---

SN 77-880,803. MADSTONE COMPANY, INC., NEW YORK, NY. FILED 11-25-2009.

## MADSTONE

THE MARK CONSISTS OF STANDARD CHARACTERS WITHOUT CLAIM TO ANY PARTICULAR FONT, STYLE, SIZE, OR COLOR.

FOR FILM PRODUCTION (U.S. CLS. 100, 101 AND 107).

TEJBIR SINGH, EXAMINING ATTORNEY

**CLASS 41—(Continued).**

SN 77-884,985. NATIONAL GEOGRAPHIC SOCIETY, WASHINGTON, DC. FILED 12-3-2009.

## NAT GEO QUIZ!

THE MARK CONSISTS OF STANDARD CHARACTERS WITHOUT CLAIM TO ANY PARTICULAR FONT, STYLE, SIZE, OR COLOR.

OWNER OF U.S. REG. NOS. 524,810, 2,411,079 AND OTHERS.

NO CLAIM IS MADE TO THE EXCLUSIVE RIGHT TO USE "QUIZ", APART FROM THE MARK AS SHOWN.

FOR ENTERTAINMENT SERVICES, NAMELY, PROVIDING ON-LINE COMPUTER GAMES AND VIDEO GAMES AND PROVIDING TEMPORARY USE OF NON-DOWNLOADABLE COMPUTER GAMES AND VIDEO GAMES (U.S. CLS. 100, 101 AND 107).

HEATHER BIDDULPH, EXAMINING ATTORNEY

---

SN 77-897,847. PROMOFILM US LLC, HIALEAH, FL. FILED 12-21-2009.

## INVASIÓN CASERA

THE MARK CONSISTS OF STANDARD CHARACTERS WITHOUT CLAIM TO ANY PARTICULAR FONT, STYLE, SIZE, OR COLOR.

NO CLAIM IS MADE TO THE EXCLUSIVE RIGHT TO USE "CASERA", APART FROM THE MARK AS SHOWN.

THE ENGLISH TRANSLATION OF "INVASION CASERA" IN THE MARK IS "HOME INVASION".

FOR ENTERTAINMENT SERVICES, NAMELY, A TELEVISION SERIES FEATURING REMODELING OF RESIDENCES (U.S. CLS. 100, 101 AND 107).

BARNEY CHARLON, EXAMINING ATTORNEY

---

SN 77-905,688. RAIMONDI HORTICULTURAL GROUP, INC., HO-HO-KUS, NJ. FILED 1-5-2010.

## LFS PRODUCTIONS

THE MARK CONSISTS OF STANDARD CHARACTERS WITHOUT CLAIM TO ANY PARTICULAR FONT, STYLE, SIZE, OR COLOR.

NO CLAIM IS MADE TO THE EXCLUSIVE RIGHT TO USE "PRODUCTIONS", APART FROM THE MARK AS SHOWN.

FOR SPECIAL EVENT PLANNING (U.S. CLS. 100, 101 AND 107).

FIRST USE 1-1-2009; IN COMMERCE 1-1-2009.

SCOTT BIBB, EXAMINING ATTORNEY

**CLASS 41—(Continued).**

SN 77-929,486. BLOOM, MIRIAM, DBA SCIWRITE, SALT LAKE CITY, UT. FILED 2-5-2010.

# SciWrite

THE MARK CONSISTS OF STANDARD CHARACTERS WITHOUT CLAIM TO ANY PARTICULAR FONT, STYLE, SIZE, OR COLOR.

FOR PUBLICATION AND EDITING OF PRINTED MATTER; WRITTEN TEXT EDITING (U.S. CLS. 100, 101 AND 107).

FIRST USE 9-0-1991; IN COMMERCE 9-0-1991.  
RAUL CORDOVA, EXAMINING ATTORNEY

**CLASS 41—(Continued).**

SN 77-931,604. START-UP LAB INC., MIAMI BEACH, FL. FILED 2-9-2010.

# Start-Up Lab

THE MARK CONSISTS OF STANDARD CHARACTERS WITHOUT CLAIM TO ANY PARTICULAR FONT, STYLE, SIZE, OR COLOR.

NO CLAIM IS MADE TO THE EXCLUSIVE RIGHT TO USE "START-UP", APART FROM THE MARK AS SHOWN.

FOR ENTERTAINMENT MEDIA PRODUCTION SERVICES FOR MOTION PICTURES, TELEVISION AND INTERNET; ENTERTAINMENT SERVICES IN THE NATURE OF AN ON-GOING REALITY BASED TELEVISION PROGRAM; ENTERTAINMENT SERVICES IN THE NATURE OF CREATION, DEVELOPMENT, AND PRODUCTION OF TELEVISION PROGRAMMING (U.S. CLS. 100, 101 AND 107).

MICHAEL ENGEL, EXAMINING ATTORNEY

SN 77-931,478. W2007 STRATOSPHERE PROPCO, L.P., LAS VEGAS, NV. FILED 2-9-2010.



OWNER OF U.S. REG. NOS. 2,086,400, 2,086,401 AND 3,212,812.

NO CLAIM IS MADE TO THE EXCLUSIVE RIGHT TO USE "LAS VEGAS", APART FROM THE MARK AS SHOWN.

THE MARK CONSISTS OF THE WORDS "SKY JUMP STRATOSPHERE LAS VEGAS" STAGGERED AND VERTICALLY POSITIONED OVER A TARGET.

FOR ENTERTAINMENT IN THE NATURE OF AN AMUSEMENT PARK RIDE; AND ENTERTAINMENT SERVICES, NAMELY, CONDUCTING PARTIES (U.S. CLS. 100, 101 AND 107).

PAUL E. FAHRENKOPF, EXAMINING ATTORNEY

SN 77-934,129. COSTIGAN, MICHAEL A, MARIETTA, GA. FILED 2-11-2010.

# REO ROCKSTARS

THE MARK CONSISTS OF STANDARD CHARACTERS WITHOUT CLAIM TO ANY PARTICULAR FONT, STYLE, SIZE, OR COLOR.

NO CLAIM IS MADE TO THE EXCLUSIVE RIGHT TO USE "REO", APART FROM THE MARK AS SHOWN.

FOR EDUCATIONAL SERVICES, NAMELY, PROVIDING INTERACTIVE ON-LINE TRAINING SERVICES IN THE FIELD OF REAL ESTATE VIA A WEBSITE; EDUCATIONAL SERVICES, NAMELY, PROVIDING CLASSES, SEMINARS AND WORKSHOPS IN THE FIELDS OF REAL ESTATE (U.S. CLS. 100, 101 AND 107).

FIRST USE 5-13-2008; IN COMMERCE 5-13-2008.  
SETH A. RAPPAPORT, EXAMINING ATTORNEY

**CLASS 41—(Continued).**

SN 77-934,191. MCGEE, MARK E. DBA SHARK SHACK MEDIA, CHICO, CA. FILED 2-12-2010.

## SHARK SHACK RADIO

THE MARK CONSISTS OF STANDARD CHARACTERS WITHOUT CLAIM TO ANY PARTICULAR FONT, STYLE, SIZE, OR COLOR.

NO CLAIM IS MADE TO THE EXCLUSIVE RIGHT TO USE "RADIO", APART FROM THE MARK AS SHOWN.

FOR RADIO PROGRAM SYNDICATION; PRODUCTION AND DISTRIBUTION OF RADIO PROGRAMS; ENTERTAINMENT SERVICES, NAMELY, PROVIDING AN ON-GOING RADIO PROGRAM FEATURING MUSIC AND INTERVIEWS ACCESSIBLE BY RADIO, TELEVISION, CABLE TELEVISION, SATELLITE, AND GLOBAL COMMUNICATIONS AND ELECTRONIC NETWORKS; ENTERTAINMENT SERVICES, NAMELY, PROVIDING AN ON-GOING RADIO PROGRAM FEATURING INFORMATION IN THE FIELDS OF ENTERTAINMENT, FASHION, LIFESTYLE, SPORTS, AND COMEDY ACCESSIBLE BY RADIO, TELEVISION, CABLE TELEVISION, SATELLITE, AND GLOBAL COMMUNICATIONS AND ELECTRONIC NETWORKS (U.S. CLS. 100, 101 AND 107).

FIRST USE 12-31-2009; IN COMMERCE 12-31-2009.  
VERNA BETH RIRIE, EXAMINING ATTORNEY

SN 77-937,235. SCHOOL IMPROVEMENT NETWORK, INC., MIDVALE, UT. FILED 2-17-2010.

## 360° Framework

THE MARK CONSISTS OF STANDARD CHARACTERS WITHOUT CLAIM TO ANY PARTICULAR FONT, STYLE, SIZE, OR COLOR.

FOR EDUCATION SERVICES, NAMELY, PROVIDING ONLINE AND LIVE TRAINING IN THE FORM OF CLASSES, SEMINARS, CONFERENCES, PERSONAL COACHING SESSIONS, AND WORKSHOPS TO EDUCATORS IN THE FIELD OF SYSTEMIC LEARNING THEORIES FOR THE PURPOSE OF INCREASING TEACHER AND ADMINISTRATOR EFFECTIVENESS AND IMPROVING STUDENT ACHIEVEMENT, AND DISTRIBUTION OF PRINTED AND/OR ONLINE MATERIALS IN CONNECTION THEREWITH IN HARD COPY AND/OR ELECTRONIC FORMAT ON THE SAME TOPICS (U.S. CLS. 100, 101 AND 107).

ROBERT C. CLARK JR., EXAMINING ATTORNEY

**CLASS 41—(Continued).**

SN 77-941,296. LINCOLN-TON-LINCOLN COUNTY CHAMBER OF COMMERCE, LINCOLN-TON, GA. FILED 2-22-2010.



NO CLAIM IS MADE TO THE EXCLUSIVE RIGHT TO USE "THURMOND", "GA", "SC" AND "US 378", APART FROM THE MARK AS SHOWN.

THE COLOR(S) GREEN, RED, YELLOW, BLUE AND BLACK IS/ARE CLAIMED AS A FEATURE OF THE MARK.

THE MARK CONSIST OF RED, GREEN, YELLOW, AND BLUE FIREWORKS IN SKY WITH A GREEN BRIDGE WITH A YELLOW RAILING SPANNING OVER BLUE WATER CONNECTING TWO PIECES OF LAND WITH TWO GREEN TREES EACH. THE WORDS "THUNDER OVER THURMOND" APPEAR IN THE COLORS YELLOW AND RED ABOVE THE GREEN BRIDGE WITH THE WORD "THUNDER" OUTLINED IN BLUE AND WITH "GA" IN BOTTOM CORNER AND "SC" IN THE OTHER CORNER IN THE COLOR YELLOW AND OUTLINED IN RED. THE DESIGN IS IN A BLACK CIRCLE WITH A RED OUTLINE. "US 378" IS IN YELLOW WITHIN A GREEN RECTANGLE OUTLINED IN RED IN THE BLUE WATER.

FOR ORGANIZING COMMUNITY FESTIVALS FEATURING A VARIETY OF ACTIVITIES, NAMELY, SPORTING EVENTS, ART EXHIBITIONS, FLEA MARKETS, ETHNIC DANCES AND THE LIKE (U.S. CLS. 100, 101 AND 107).

FIRST USE 7-6-2002; IN COMMERCE 2-20-2010.  
ARETHA SOMERVILLE, EXAMINING ATTORNEY

SN 77-942,711. RIDEMAKERZ, LLC, IRVINE, CA. FILED 2-23-2010.

## RIDEMAKERZ STACK'RZ

THE MARK CONSISTS OF STANDARD CHARACTERS WITHOUT CLAIM TO ANY PARTICULAR FONT, STYLE, SIZE, OR COLOR.

OWNER OF U.S. REG. NOS. 3,332,495, 3,468,701 AND OTHERS.

FOR ENTERTAINMENT SERVICES, NAMELY, PROVIDING VIRTUAL ENVIRONMENTS IN WHICH USERS CAN INTERACT FOR RECREATIONAL, LEISURE OR ENTERTAINMENT PURPOSES; AND PROVIDING ONLINE VIDEO GAMES OF VIRTUAL REALITY IN WHICH USERS CREATE AND INTERACT WITHIN VIRTUAL ENVIRONMENTS, INTERACT SOCIALLY AND PLAY GAMES (U.S. CLS. 100, 101 AND 107).

C. DIONNE CLYBURN, EXAMINING ATTORNEY

**CLASS 41—(Continued).**

SN 77-962,605. DIGITAL RECORDS, INC., LOS ANGELES, CA. FILED 3-18-2010.



NO CLAIM IS MADE TO THE EXCLUSIVE RIGHT TO USE "DIGITAL RECORDS", APART FROM THE MARK AS SHOWN.

THE MARK CONSISTS OF THE IMAGE OF A BROKEN RECORD, WITH THE WORDING "DIGITAL RECORDS".

FOR AUDIO RECORDING AND PRODUCTION; ENTERTAINMENT SERVICES IN THE NATURE OF RECORDING, PRODUCTION AND POST-PRODUCTION SERVICES IN THE FIELDS OF MUSIC; ENTERTAINMENT SERVICES, NAMELY, PROVIDING A WEB SITE FEATURING NON-DOWNLOADABLE MUSICAL PERFORMANCES, MUSICAL VIDEOS, RELATED FILM CLIPS, PHOTOGRAPHS, AND OTHER MULTIMEDIA MATERIALS FEATURING MUSICAL ARTISTS; MUSIC PRODUCTION SERVICES; PROVIDING A WEBSITE FEATURING INFORMATION IN THE FIELD OF MUSIC AND ENTERTAINMENT (U.S. CLS. 100, 101 AND 107).  
JOHN KELLY, EXAMINING ATTORNEY

SN 77-962,970. ROLLAPALUZA LTD, LONDON, UNITED KINGDOM, FILED 3-19-2010.

# Goldsprint

THE MARK CONSISTS OF STANDARD CHARACTERS WITHOUT CLAIM TO ANY PARTICULAR FONT, STYLE, SIZE, OR COLOR.

OWNER OF UNITED KINGDOM REG. NO. 2509037, DATED 6-19-2009, EXPIRES 2-18-2019.

FOR PRODUCTION AND ORGANISATION OF SPORTS TOURNAMENTS, SPORTS ACTIVITIES, SPORTS COMPETITIONS, SPORTS CONTESTS AND SPORTS EVENTS NAMELY, BICYCLE RACES, BICYCLE TOURS AND PARTICIPATION RIDES, BICYCLE TIME TRIALS, STATIC BICYCLE RACES, DUATHLON, TRIATHLON AND BICYCLE EVENTS WITHIN OTHER SPORTING EVENTS OR MULTI-DISCIPLINE EVENTS; RENTAL OF SPORTS EQUIPMENT AND PROVISION SPORTS FACILITIES; INSTRUCTION AND COACHING IN SPORTS; EDUCATIONAL SERVICES RELATED TO SPORTS, NAMELY, CLASSES AND TRAINING; INFORMATION SERVICES RELATED TO SPORTS; OFFICIATING AT SPORTS TOURNAMENTS, SPORTS ACTIVITIES, SPORTS COMPETITIONS, SPORTS CONTEST AND SPORTS EVENTS; SPORTS TRAINING; SPORTS INFORMATION SERVICES; TICKET PROCUREMENT SERVICES FOR SPORTS EVENTS,

**CLASS 41—(Continued).**

NAMELY, TICKET RESERVATION AND BOOKING SERVICES; ORGANIZING OF LIVE MUSICAL CONCERTS; ARRANGING OF MUSIC PERFORMANCES, NAMELY, BOOKING AND PRODUCING OF LIVE CONCERTS; ARRANGING OF MUSICAL ENTERTAINMENT, NAMELY, BOOKING AND PRODUCING OF LIVE CONCERTS; MUSIC FESTIVAL SERVICES, NAMELY, ORGANIZING COMMUNITY FESTIVALS FEATURING LIVE MUSIC; ORGANISATION OF LIVE MUSICAL CONCERTS; PRESENTATION OF MUSICAL CONCERTS; ARRANGING OF COMPETITIONS FOR ENTERTAINMENT PURPOSES, NAMELY, COMPETITIONS IN THE FIELD OF BICYCLE RACING, STATIC BICYCLE RACING; ARRANGING OF FESTIVALS FOR ENTERTAINMENT PURPOSES, NAMELY, FESTIVALS IN THE FIELD OF SPORT OR MUSIC; ORGANIZING OF COMPETITIONS FOR ENTERTAINMENT, NAMELY, ORGANIZING ENTERTAINMENT COMPETITIONS IN THE FIELD OF BICYCLE SPORT AND MULTI-DISCIPLINE SPORT (U.S. CLS. 100, 101 AND 107).

EUGENIA MARTIN, EXAMINING ATTORNEY

SN 77-967,443. SYZYGY, LLC, REDONDO, CA. FILED 3-24-2010.

# SYZYGY

THE MARK CONSISTS OF STANDARD CHARACTERS WITHOUT CLAIM TO ANY PARTICULAR FONT, STYLE, SIZE, OR COLOR.

FOR PHYSICAL FITNESS INSTRUCTION IN THE FIELDS OF INDOOR CYCLING, YOGA AND PILATES (U.S. CLS. 100, 101 AND 107).

HEATHER THOMPSON, EXAMINING ATTORNEY

SN 77-967,496. SYZYGY, LLC, REDONDO, CA. FILED 3-24-2010.

# SYZYGY CYCLING

THE MARK CONSISTS OF STANDARD CHARACTERS WITHOUT CLAIM TO ANY PARTICULAR FONT, STYLE, SIZE, OR COLOR.

NO CLAIM IS MADE TO THE EXCLUSIVE RIGHT TO USE "CYCLING", APART FROM THE MARK AS SHOWN.

FOR PHYSICAL FITNESS INSTRUCTION IN THE FIELDS OF INDOOR CYCLING, YOGA AND PILATES (U.S. CLS. 100, 101 AND 107).

HEATHER THOMPSON, EXAMINING ATTORNEY

**CLASS 41—(Continued).**

SN 77-969,707. UPTOTEN PRIVATE SOCIETY MAURITIUS, PORT LOUIS, MAURITIUS, FILED 3-26-2010.

# UpToTen

THE MARK CONSISTS OF STANDARD CHARACTERS WITHOUT CLAIM TO ANY PARTICULAR FONT, STYLE, SIZE, OR COLOR.

FOR ENTERTAINMENT SERVICES FOR YOUNG CHILDREN, NAMELY, PROVIDING A WEBSITE FEATURING ON-LINE COMPUTER GAMES, PUZZLES, SONGS, ON-LINE CARD GAMES FEATURING ANIMATED CARDS, AND EDUCATIONAL ACTIVITIES IN THE NATURE OF GAMES, PROVIDED VIA A GLOBAL COMPUTER NETWORK (U.S. CLS. 100, 101 AND 107).

FIRST USE 12-1-1999; IN COMMERCE 12-1-1999.  
EVELYN BRADLEY, EXAMINING ATTORNEY

---

SN 78-416,505. SHENERGY HOLDINGS INC., GLENDALE, CA. FILED 5-11-2004.

# Shenology

THE MARK CONSISTS OF STANDARD CHARACTERS WITHOUT CLAIM TO ANY PARTICULAR FONT, STYLE, SIZE, OR COLOR.

FOR EDUCATIONAL SERVICES, NAMELY, CONDUCTING CLASSES, SEMINARS, WORKSHOPS, AND PRIVATE TUTORIAL SESSIONS IN PERSONAL AWARENESS AND IN THE FIELD OF HEALTH, WELLNESS, LONGEVITY, AND SPIRITUALITY (U.S. CLS. 100, 101 AND 107).

JEFF DEFORD, EXAMINING ATTORNEY

**CLASS 41—(Continued).**

SN 79-078,187. BENCHMARK SPORT LIMITED, UNITED KINGDOM, FILED 10-30-2009.



## SPORT INDUSTRY AWARDS

OWNER OF INTERNATIONAL REGISTRATION 1027053 DATED 10-30-2009, EXPIRES 10-30-2019.

NO CLAIM IS MADE TO THE EXCLUSIVE RIGHT TO USE "SPORT INDUSTRY AWARDS", APART FROM THE MARK AS SHOWN.

THE MARK CONSISTS OF A STYLIZED "S" ENCOMPASSED BY A SHADED CIRCLE, WHICH APPEARS ABOVE THE WORDING "SPORT INDUSTRY AWARDS".

FOR ORGANIZATION OF SPORTS COMPETITIONS; ENTERTAINMENT SERVICES IN THE NATURE OF AN ANNUAL AWARDS PROGRAM FOR THE PRESENTATION OF AWARDS IN RECOGNITION OF DISTINGUISHED ACHIEVEMENT IN THE SPORTS INDUSTRY; DISTRIBUTION AND PRODUCTION OF FILMS AND RADIO AND TELEVISION PROGRAMMING; PRESENTATION OF FILMS AND RADIO AND TELEVISION PROGRAMMING; PUBLISHING SERVICES, NAMELY, DIGITAL VIDEO, AUDIO AND MULTI-MEDIA PUBLISHING SERVICES, MUSIC PUBLISHING SERVICES; PUBLICATION OF BOOKS, TEXTBOOKS, MAGAZINES, NEWSPAPERS, JOURNALS, MANUALS, PERIODICALS, NEWSLETTERS, PAMPHLETS AND BROCHURES; ELECTRONIC PUBLISHING, NAMELY, ON-LINE ELECTRONIC PUBLISHING OF BOOKS AND PERIODICALS, PUBLISHING OF ELECTRONIC PUBLICATIONS, PUBLISHING OF ELECTRONIC JOURNALS, MANUALS, NEWSLETTERS AND BROCHURES; ORGANIZING EXHIBITIONS FOR CULTURAL, EDUCATION, INSTRUCTION, ENTERTAINMENT AND SPORTING PURPOSES; ORGANIZATION, ARRANGEMENT AND CONDUCTING OF CONFERENCES IN THE FIELD OF ENTERTAINMENT, TRAVEL, ART, CURRENT AFFAIRS AND SPORTS; AWARD CEREMONIES FOR ATHLETIC AND SPORTING TOURNAMENTS AND COMPETITIONS; AWARD CEREMONIES FOR THE RECOGNITION OF THE PROGRESS AND ACHIEVEMENT OF PROFESSIONALS AND INDIVIDUALS IN THE FIELDS OF COMMUNITY SPORTS PROJECTS, SPORTS, CHARITABLE PROJECTS, JOURNALISM, POPULAR ENTERTAINMENT, PROMOTIONS, SPORTS PROMOTION, CHARITY PROMOTION SPORTS AGENCIES, SPONSORSHIP OF SPORTS EVENTS, LEADERSHIP, SPORTS LEADERSHIP ADVERTISING, SPORTS ADVERTISING, MARKETING, SPORTS MARKETING; INCENTIVE AWARD PROGRAMS TO ENCOURAGE EXCELLENCE IN THE FIELD OF SPORT THROUGH THE ISSUANCE OF AWARDS; EDUCATIONAL SERVICES, NAMELY, LECTURES IN THE FIELD OF PERSONAL AWARENESS, SPORT, BUSINESS, ENTERTAINMENT, TRAVEL, HISTORY, ART, AND CURRENT AFFAIRS; ENTERTAINMENT SERVICES, NAMELY, PRODUCTION AND DISTRIBUTION OF A QUIZ SHOW; ORGANIZING EXHIBITIONS FOR CULTURAL OR EDUCATIONAL PURPOSES, NAMELY, EXHIBITIONS IN THE FIELDS OF ART, SPORT, MUSIC, BUSINESS, TRAVEL, HISTORY, AND CURRENT AFFAIRS; SPORTING EVENTS IN THE NATURE OF SWIM MEETS, SOCCER COMPETITIONS AND ATHLETIC COMPETITIONS; THEATRICAL PERFORMANCES; ORGANIZATION OF SPORTS COMPETITIONS; PRODUCTION OF AWARD SHOWS RELATING TO SPORTING EVENTS, COACHING, TRAINING AND EDUCATION;

**CLASS 41—(Continued).**

PUBLISHING OF SPORTING MATERIALS, NAMELY, PUBLISHING OF SPORTS BOOKS, BOOKS, SPORTS TEXT BOOKS, SPORTS MAGAZINES, SPORTS NEWSPAPERS, SPORTS JOURNALS, SPORTS MANUALS, SPORTS PERIODICALS AND SPORTS NEWSLETTERS; EDUCATION IN THE FIELD OF SPORTS AND PERSONAL DEVELOPMENT RENDERED THROUGH CORRESPONDENCE COURSES; PROVISION OF NON-DOWNLOADABLE PUBLICATIONS IN THE NATURE OF BOOKS, TEXTBOOKS, MAGAZINES, NEWSPAPERS, JOURNALS, MANUALS, PERIODICALS, NEWSLETTERS, PAMPHLETS AND BROCHURES IN THE FIELD OF SPORTS; EDUCATION SERVICES IN THE NATURE OF CLASSES, SEMINARS, LECTURES AND CONFERENCES IN THE FIELD OF SPORT AND PERSONAL DEVELOPMENT; TRAINING SERVICES IN THE FIELD OF SPORT AND PERSONAL DEVELOPMENT; PROVIDING ADVISORY AND CONSULTANCY SERVICES RELATING TO THE AFORESAID ENTERTAINMENT AND EDUCATIONAL SERVICE; PROVIDING ENTERTAINMENT INFORMATION RELATING TO THE AFOREMENTIONED SERVICES (U.S. CLS. 100, 101 AND 107).

ELI HELLMAN, EXAMINING ATTORNEY

SN 79-091,375. SIRIUS ENTERTAINMENT CO., LTD, REPUBLIC OF KOREA, FILED 11-17-2010.

# LIME ODYSSEY

THE MARK CONSISTS OF STANDARD CHARACTERS WITHOUT CLAIM TO ANY PARTICULAR FONT, STYLE, SIZE, OR COLOR.

PRIORITY DATE OF 8-26-2010 IS CLAIMED.  
OWNER OF INTERNATIONAL REGISTRATION 1061993 DATED 11-17-2010, EXPIRES 11-17-2020.

FOR GAME SERVICES PROVIDED ON-LINE FROM A COMPUTER NETWORK (U.S. CLS. 100, 101 AND 107).  
SANI KHOURI, EXAMINING ATTORNEY

SN 85-000,491. SARPONG, JUNE, LONDON, ENGLAND, FILED 3-29-2010.

# NEWSDISH

THE MARK CONSISTS OF STANDARD CHARACTERS WITHOUT CLAIM TO ANY PARTICULAR FONT, STYLE, SIZE, OR COLOR.

FOR ENTERTAINMENT SERVICES, NAMELY, AN ON-GOING SERIES FEATURING COOKING AND CURRENT EVENT REPORTING AND DISCUSSION PROVIDED THROUGH TELEVISION AND WEBCAST; PROVIDING CURRENT EVENT NEWS AND INFORMATION VIA A GLOBAL COMPUTER NETWORK (U.S. CLS. 100, 101 AND 107).

WENDY GOODMAN, EXAMINING ATTORNEY

**CLASS 41—(Continued).**

SN 85-006,565. MATVIL CORPORATION, NORTH YORK, ONTARIO, CANADA, FILED 4-5-2010.

# ETVNET

THE MARK CONSISTS OF STANDARD CHARACTERS WITHOUT CLAIM TO ANY PARTICULAR FONT, STYLE, SIZE, OR COLOR.

OWNER OF CANADA REG. NO. TMA749284, DATED 10-2-2009, EXPIRES 10-2-2024.

FOR ENTERTAINMENT SERVICES, NAMELY, THE DEVELOPMENT, PRODUCTION AND DISTRIBUTION OF TELEVISION PROGRAMMING, MOVIES AND DOCUMENTARY FILMS VIA THE INTERNET (U.S. CLS. 100, 101 AND 107).

FIRST USE 11-1-2004; IN COMMERCE 11-1-2004.  
ROBERT STRUCK, EXAMINING ATTORNEY

SN 85-011,817. MURMUR FILMS INC., TORONTO, ONTARIO, CANADA, FILED 4-12-2010.

# M F U R M U R

NO CLAIM IS MADE TO THE EXCLUSIVE RIGHT TO USE "FILMS", APART FROM THE MARK AS SHOWN.

THE MARK CONSISTS OF UPPERCASE LETTERS, "MURMUR" AND "FILMS", WITH THE WORD "FILMS" IN BETWEEN EACH OF THE "MURMUR" LETTERS, SLIGHTLY LOWER THAN BASELINE.

FOR FILM AND TELEVISION PRODUCTION SERVICES, NAMELY, POST PRODUCTION EDITING SERVICES FOR FEATURES AND TELEVISION (U.S. CLS. 100, 101 AND 107).

FIRST USE 11-21-1997; IN COMMERCE 10-30-1998.  
EUGENIA MARTIN, EXAMINING ATTORNEY

SN 85-012,719. SCHOOLNET, INC., NEW YORK, NY. FILED 4-13-2010.

# EVERY TEACHER, EVERY DAY

THE MARK CONSISTS OF STANDARD CHARACTERS WITHOUT CLAIM TO ANY PARTICULAR FONT, STYLE, SIZE, OR COLOR.

FOR EDUCATIONAL SERVICES, NAMELY, PROVIDING CLASSES, SEMINARS AND WORKSHOPS IN THE FIELD OF EDUCATION FOR EDUCATORS AND DISTRIBUTION OF PRINTED MATERIALS IN CONNECTION THEREWITH; TRAINING IN THE USE AND OPERATION OF SOFTWARE FOR EDUCATORS; PROVIDING EDUCATIONAL MENTORING SERVICES AND PROGRAMS IN THE FIELD OF EDUCATION (U.S. CLS. 100, 101 AND 107).

ALICE BENMAMAN, EXAMINING ATTORNEY

**CLASS 41—(Continued).**

SN 85-012,813. ROSE-DRECKSLER, RHONDA, MIAMI, FL. FILED 4-13-2010.

## Empower a Student

THE MARK CONSISTS OF STANDARD CHARACTERS WITHOUT CLAIM TO ANY PARTICULAR FONT, STYLE, SIZE, OR COLOR.

FOR CONDUCTING AFTER-SCHOOL TUTORING PROGRAMS FOR ABUSED AND NEGLECTED CHILDREN; EDUCATION SERVICES, NAMELY, PROVIDING PRE-KINDERGARTEN THROUGH 12TH GRADE CLASSROOM INSTRUCTION, VOCATIONAL INSTRUCTION, MENTORING, TUTORING, CLASSES, SEMINARS AND WORKSHOPS FOR INDIVIDUALS WITH AUTISM AND OTHER DEVELOPMENTAL DISORDERS (U.S. CLS. 100, 101 AND 107).

FIRST USE 3-3-2010; IN COMMERCE 3-3-2010.  
LINDA E. BLOHM, EXAMINING ATTORNEY

---

SN 85-015,381. KNOWLEDGE ADVOCATE, LLC., AUSTIN, TX. FILED 4-15-2010.

## WELL TALK

THE MARK CONSISTS OF STANDARD CHARACTERS WITHOUT CLAIM TO ANY PARTICULAR FONT, STYLE, SIZE, OR COLOR.

NO CLAIM IS MADE TO THE EXCLUSIVE RIGHT TO USE "TALK", APART FROM THE MARK AS SHOWN.

FOR EDUCATION SERVICES, NAMELY, PROVIDING SEMINARS, PROGRAMS AND TRAINING SESSIONS TO TEACH PEOPLE HOW TO TALK TO OR COMMUNICATE WITH EACH OTHER (U.S. CLS. 100, 101 AND 107).

FIRST USE 2-1-2010; IN COMMERCE 2-1-2010.  
ALICIA COLLINS, EXAMINING ATTORNEY

---

SN 85-017,396. HOPLON INFOTAINMENT S.A., FLORIANOPOLIS - SC, BRAZIL, FILED 4-19-2010.

## TAIKODOM LIVING UNIVERSE

THE MARK CONSISTS OF STANDARD CHARACTERS WITHOUT CLAIM TO ANY PARTICULAR FONT, STYLE, SIZE, OR COLOR.

FOR ENTERTAINMENT SERVICES, NAMELY, PROVIDING A WEB SITE FEATURING NON-DOWNLOADABLE MUSICAL PERFORMANCES, MUSICAL VIDEOS, RELATED FILM CLIPS, PHOTOGRAPHS, AND OTHER MULTIMEDIA MATERIALS FEATURING MOVIES, COMPUTER GAMES AND ANIMATIONS; ENTERTAINMENT SERVICES, NAMELY, PROVIDING ON-LINE COMPUTER GAMES (U.S. CLS. 100, 101 AND 107).

EMILY CHUO, EXAMINING ATTORNEY

**CLASS 41—(Continued).**

SN 85-017,487. ROLLINS, INC., ATLANTA, GA. FILED 4-19-2010.

NO CLAIM IS MADE TO THE EXCLUSIVE RIGHT TO USE "BUGS", APART FROM THE MARK AS SHOWN.

THE COLOR(S) BLACK, RED AND YELLOW IS/ARE CLAIMED AS A FEATURE OF THE MARK.

THE MARK CONSISTS OF THE WORDS "BUGS RUIN" IN BLACK LETTERS, THE WORD "EVERYTHING" IN RED LETTERS AND .COM IN YELLOW LETTERS.

FOR PROVIDING A WEBSITE FOR ENTERTAINMENT PURPOSES WHERE USERS CAN VIEW AND POST VIDEOS FEATURING ANIMAL AND/OR INSECT PEST BEHAVIOR; ENTERTAINMENT SERVICES, NAMELY AN ONLINE CONTEST RELATING TO SELECTION OF PEST CONTROL VIDEOS (U.S. CLS. 100, 101 AND 107).

DOMINIC J. FERRAIUOLO, EXAMINING ATTORNEY

---

SN 85-017,546. BOOT ROYALTY COMPANY, L.P., FORT WORTH, TX. FILED 4-19-2010.

## JUSTIN BEST FOOTING AWARDS

THE MARK CONSISTS OF STANDARD CHARACTERS WITHOUT CLAIM TO ANY PARTICULAR FONT, STYLE, SIZE, OR COLOR.

OWNER OF U.S. REG. NOS. 2,020,461, 2,160,449 AND 3,194,362.

NO CLAIM IS MADE TO THE EXCLUSIVE RIGHT TO USE "AWARDS", APART FROM THE MARK AS SHOWN. SEC. 2(F) AS TO "BEST FOOTING".

FOR AWARDS PROGRAM, NAMELY, PROVIDING RECOGNITION FOR EXCELLENCE IN THE FIELD OF MAINTAINING THE BEST GROUND CONDITIONS FOR RODEO ACTIVITIES (U.S. CLS. 100, 101 AND 107).

FIRST USE 0-0-1995; IN COMMERCE 0-0-1995.  
MARTHA FROMM, EXAMINING ATTORNEY



**CLASS 41—(Continued).**

SN 85-017,752. SCOTT ADAMS, DBA SHOWDOWN FIGHTS, SAN LUIS OBISPO, CA. FILED 4-19-2010.

## Showdown Fights

THE MARK CONSISTS OF STANDARD CHARACTERS WITHOUT CLAIM TO ANY PARTICULAR FONT, STYLE, SIZE, OR COLOR.

NO CLAIM IS MADE TO THE EXCLUSIVE RIGHT TO USE "FIGHTS", APART FROM THE MARK AS SHOWN.

FOR ENTERTAINMENT SERVICES, NAMELY, ORGANIZING, ARRANGING CONDUCTING, BOXING, GRAPPLING, WRESTLING, MARTIAL ARTS AND MIXED MARTIAL ARTS (MMA) EVENTS AND COMPETITIONS RENDERED LIVE AND RECORDED FOR THE PURPOSE OF DISTRIBUTION THROUGH BROADCAST MEDIA; PROVIDING WEBSITES ON THE INTERNET FEATURING NEWS AND INFORMATION ABOUT MARTIAL ARTS AND MIXED MARTIAL ARTS AND PROVIDING A WEBSITE ON THE INTERNET FEATURING NEWS AND INFORMATION REGARDING COMBINATION OF BOXING, GRAPPLING, WRESTLING, MARTIAL ARTS AND MIXED MARTIAL ARTS (MMA)-COMPETITIONS AND EVENTS; PRODUCTION OF DVD'S FEATURING MARTIAL ARTS AND MIXED MARTIAL ARTS (U.S. CLS. 100, 101 AND 107).

FIRST USE 12-8-2009; IN COMMERCE 3-9-2010.

MARGERY A. TIERNEY, EXAMINING ATTORNEY

SN 85-018,915. BURKS, JESSICA, LOS ANGELES, CA. FILED 4-20-2010.



THE COLOR(S) PINK IS/ARE CLAIMED AS A FEATURE OF THE MARK.

THE MARK CONSISTS OF THE WORDS "FEELING FABULOUS" IN PINK, CURSIVE LETTERING.

FOR EDUCATIONAL SERVICES FOCUSING ON BUILDING THE SELF-ESTEEM OF WOMEN, NAMELY, THROUGH, CONDUCTING LECTURES, WORKSHOPS, CLASSES, SEMINARS, CAMPS, PROGRAMS, AND OUTREACH, AND DISTRIBUTING COURSE MATERIALS THEREWITH (U.S. CLS. 100, 101 AND 107).

FIRST USE 12-1-2009; IN COMMERCE 12-1-2009.

ANNE E. GUSTASON, EXAMINING ATTORNEY

**CLASS 41—(Continued).**

SN 85-019,055. PFIP, LLC, NEWINGTON, NH. FILED 4-21-2010.

## ONE GYM HAS EVOLVED BEYOND GRUNTING

THE MARK CONSISTS OF STANDARD CHARACTERS WITHOUT CLAIM TO ANY PARTICULAR FONT, STYLE, SIZE, OR COLOR.

FOR PHYSICAL FITNESS INSTRUCTION AND TRAINING; HEALTH CLUB SERVICES, NAMELY, PROVIDING INSTRUCTION AND EQUIPMENT IN THE FIELD OF PHYSICAL EXERCISE (U.S. CLS. 100, 101 AND 107).

BRIAN PINO, EXAMINING ATTORNEY

SN 85-019,812. VENUS FASHION, INC., JACKSONVILLE, FL. FILED 4-21-2010.



THE MARK CONSISTS OF STANDARD CHARACTERS WITHOUT CLAIM TO ANY PARTICULAR FONT, STYLE, SIZE, OR COLOR.

OWNER OF U.S. REG. NO. 2,866,965.

FOR PROVIDING ONLINE PUBLICATIONS IN THE NATURE OF NEWSLETTERS IN THE FIELD OF FASHION (U.S. CLS. 100, 101 AND 107).

FIRST USE 5-0-2005; IN COMMERCE 5-0-2005.

JOSETTE BEVERLY, EXAMINING ATTORNEY

SN 85-021,145. JORDAN DARIAN INC., MONROE, NY. FILED 4-22-2010.

## CRITTER CREW

THE MARK CONSISTS OF STANDARD CHARACTERS WITHOUT CLAIM TO ANY PARTICULAR FONT, STYLE, SIZE, OR COLOR.

FOR EDUCATIONAL AND ENTERTAINMENT SERVICES IN THE NATURE OF ON-GOING ANIMATED CHILDREN'S TELEVISION PROGRAMS; ENTERTAINMENT SERVICES IN THE NATURE OF INTERACTIVE ONLINE EDUCATIONAL GAMES FOR CHILDREN ON A WIDE RANGE OF TOPICS OF INTEREST TO CHILDREN; ENTERTAINMENT SERVICES IN THE NATURE OF ON-LINE NON-DOWNLOADABLE INTERACTIVE VIDEO GAMES AND MULTIMEDIA COMPUTER GAMES FOR CHILDREN AND ON-GOING TELEVISION PROGRAMS FOR CHILDREN VIA AN INTERNET WEBSITE (U.S. CLS. 100, 101 AND 107).

DOUGLAS LEE, EXAMINING ATTORNEY

**CLASS 41—(Continued).**

SN 85-021,679. LIFE PIECES TO MASTERPIECES, INC., WASHINGTON, DC. FILED 4-23-2010.

**LIFE PIECES TO MASTERPIECES**

THE MARK CONSISTS OF STANDARD CHARACTERS WITHOUT CLAIM TO ANY PARTICULAR FONT, STYLE, SIZE, OR COLOR.

OWNER OF U.S. REG. NO. 2,410,793.  
FOR EDUCATIONAL SERVICES, NAMELY, PROVIDING SEMINARS, CLASSES, AND TUTORING IN THE FIELDS OF ART, GENERAL ACADEMICS, BUSINESS DEVELOPMENT, LEADERSHIP SKILLS AND GENERAL HEALTH (U.S. CLS. 100, 101 AND 107).

FIRST USE 1-0-1996; IN COMMERCE 1-0-1999,  
CAROLINE WOOD, EXAMINING ATTORNEY

SN 85-023,102. WOLYNN, MARK, PITTSBURGH, PA. FILED 4-26-2010.

**CORE LANGUAGE**

THE MARK CONSISTS OF STANDARD CHARACTERS WITHOUT CLAIM TO ANY PARTICULAR FONT, STYLE, SIZE, OR COLOR.

FOR EDUCATIONAL SERVICES, NAMELY, CONDUCTING CLASSES, SEMINARS, WORKSHOPS, AND TRAINING SESSIONS IN THE FIELDS OF FAMILY THERAPY, PSYCHOLOGY, BEHAVIORAL AND ANCESTRAL ORIGINS, PATHOLOGY AND PSYCHOTHERAPY (U.S. CLS. 100, 101 AND 107).

SAMUEL E. SHARPER JR., EXAMINING ATTORNEY

SN 85-025,275. GOLOCAL 24, INC., PROVIDENCE, RI. FILED 4-28-2010.

**GoLocalProv**

THE MARK CONSISTS OF STANDARD CHARACTERS WITHOUT CLAIM TO ANY PARTICULAR FONT, STYLE, SIZE, OR COLOR.

FOR ON-LINE COMPUTER SERVICES IN THE NATURE OF MONTHLY COLUMNS, BLOGS, NEWSCASTS, AND VIDEOS IN THE FIELD OF LOCAL INTEREST NEWS FEATURING ENTERTAINMENT, CULTURE, SPORTS AND CURRENT EVENTS AND INFORMATION VIA A GLOBAL COMPUTER NETWORK (U.S. CLS. 100, 101 AND 107).

FIRST USE 4-0-2010; IN COMMERCE 4-0-2010,  
KEVON CHISOLM, EXAMINING ATTORNEY

**CLASS 41—(Continued).**

SN 85-025,371. GOLOCAL 24, INC., PROVIDENCE, RI. FILED 4-28-2010.

**SEE IT. READ IT. SHARE IT.**

THE MARK CONSISTS OF STANDARD CHARACTERS WITHOUT CLAIM TO ANY PARTICULAR FONT, STYLE, SIZE, OR COLOR.

FOR ON-LINE COMPUTER SERVICES IN THE NATURE OF MONTHLY COLUMNS, BLOGS, NEWSCASTS, AND VIDEOS IN THE FIELD OF LOCAL INTEREST NEWS FEATURING ENTERTAINMENT, CULTURE, SPORTS AND CURRENT EVENTS AND INFORMATION VIA A GLOBAL COMPUTER NETWORK (U.S. CLS. 100, 101 AND 107).

FIRST USE 4-0-2010; IN COMMERCE 4-0-2010,  
KEVON CHISOLM, EXAMINING ATTORNEY

SN 85-025,433. GOLOCAL 24, INC., PROVIDENCE, RI. FILED 4-28-2010.

**MINDSETTER**

THE MARK CONSISTS OF STANDARD CHARACTERS WITHOUT CLAIM TO ANY PARTICULAR FONT, STYLE, SIZE, OR COLOR.

FOR ON-LINE COMPUTER SERVICES IN THE NATURE OF MONTHLY COLUMNS, BLOGS, NEWSCASTS, AND VIDEOS IN THE FIELD OF LOCAL INTEREST NEWS FEATURING ENTERTAINMENT, CULTURE, SPORTS AND CURRENT EVENTS AND INFORMATION VIA A GLOBAL COMPUTER NETWORK (U.S. CLS. 100, 101 AND 107).

FIRST USE 4-0-2010; IN COMMERCE 4-0-2010,  
KEVON CHISOLM, EXAMINING ATTORNEY

SN 85-027,581. STRONGHER FITNESS, LLC., EDINA, MN. FILED 4-30-2010.

**STRONGHER FITNESS**

THE MARK CONSISTS OF STANDARD CHARACTERS WITHOUT CLAIM TO ANY PARTICULAR FONT, STYLE, SIZE, OR COLOR.

NO CLAIM IS MADE TO THE EXCLUSIVE RIGHT TO USE "FITNESS", APART FROM THE MARK AS SHOWN.

FOR HEALTH AND FITNESS CLUB SERVICES, NAMELY, PROVIDING FITNESS AND EXERCISE FACILITIES, AND PROVIDING EQUIPMENT AND INSTRUCTION IN THE FIELD OF PHYSICAL EXERCISE AND FITNESS (U.S. CLS. 100, 101 AND 107).

ELI HELLMAN, EXAMINING ATTORNEY

**CLASS 41—(Continued).**

SN 85-028,059. KING, BRENDON, PELZER, SC. FILED 5-1-2010.

**PROFOUND**

THE MARK CONSISTS OF STANDARD CHARACTERS WITHOUT CLAIM TO ANY PARTICULAR FONT, STYLE, SIZE, OR COLOR.

FOR ENTERTAINMENT SERVICES IN THE NATURE OF LIVE MUSICAL PERFORMANCES (U.S. CLS. 100, 101 AND 107).

JILL PRATER, EXAMINING ATTORNEY

---

SN 85-032,264. CENTER FOR EFFECTIVE PUBLIC POLICY, INC., SILVER SPRING, MD. FILED 5-6-2010.

**ONE LESS**

THE MARK CONSISTS OF STANDARD CHARACTERS WITHOUT CLAIM TO ANY PARTICULAR FONT, STYLE, SIZE, OR COLOR.

FOR EDUCATION AND TRAINING OF LOCAL CRIMINAL JUSTICE PERSONNEL, NAMELY, WORKSHOPS, CLASSES, SEMINARS AND LECTURES IN THE FIELD OF REDUCING PRETRIAL MISCONDUCT BY ACCUSED OFFENDERS, REDUCING POST-CONVICTION RECIDIVISM, AND OTHER ASPECTS OF CRIMINAL JUSTICE PREVENTION AND ENFORCEMENT (U.S. CLS. 100, 101 AND 107).

FIRST USE 5-3-2010; IN COMMERCE 5-3-2010.  
SUSAN STIGLITZ, EXAMINING ATTORNEY

---

SN 85-033,263. MICHIGAN'S CHILDREN, LANSING, MI. FILED 5-7-2010.



NO CLAIM IS MADE TO THE EXCLUSIVE RIGHT TO USE "YOUTH PUBLIC FORUM", APART FROM THE MARK AS SHOWN.

THE MARK CONSISTS OF THE WORDING "KIDSPEAK A YOUTH PUBLIC FORUM" IN A STYLIZED FONT ALL IN A CARTOON SPEAKING BUBBLE.

FOR EDUCATION SERVICES, NAMELY, PROVIDING LIVE AND ON-LINE, YOUTH FORUMS IN THE FIELD OF CIVIC ENGAGEMENT AND POLICYMAKING (U.S. CLS. 100, 101 AND 107).

FIRST USE 10-1-1996; IN COMMERCE 10-1-1996.  
KAPIL BHANOT, EXAMINING ATTORNEY

**CLASS 41—(Continued).**

SN 85-036,942. RED.COM, INC., LAKE FOREST, CA. FILED 5-12-2010.



OWNER OF U.S. REG. NOS. 3,719,995, 3,765,064 AND OTHERS.

NO CLAIM IS MADE TO THE EXCLUSIVE RIGHT TO USE "DIGITAL CINEMA", APART FROM THE MARK AS SHOWN.

THE COLOR(S) RED, GREY, BLACK AND WHITE IS/ARE CLAIMED AS A FEATURE OF THE MARK.

THE MARK CONSISTS OF THREE GREY RINGS WITH THE INNER CIRCLE BEING RED WITH WHITE SHADING, THE MIDDLE RING CONTAINING BLACK OUTLINING RESEMBLING A CAMERA IRIS AND THE OUTER RING CONTAINING THE WORKING "RED DIGITAL CINEMA" IN WHITE WITH GREY SHADING.

FOR PRODUCTION AND DISTRIBUTION SERVICES OF TELEVISION SHOWS AND MOVIE FEATURING LIVE ACTION, COMPUTER GRAPHICS AND ANIMATION; ENTERTAINMENT SERVICES IN THE FIELD OF FILM AND TELEVISION, NAMELY, THE CREATION AND PRODUCTION OF MULTIMEDIA ENTERTAINMENT CONTENT IN THE NATURE OF FILMS, VIDEOS, ANIMATION, AND COMPUTER GENERATED IMAGES, EDITING MOTION PICTURE FILMS AND TELEVISION PROGRAMMING; PRODUCTION OF VIDEO TAPE FILMS AND VIDEO DISK FILMS; MOVING SHOWING, NAMELY, MOVIE STUDIO AND THEATERS SERVICES AND PROVIDING INFORMATION THEREON; CONSULTANCY RELATING TO MOVIE STUDIO AND THEATERS SERVICES, FILM PRODUCTION OR MOVIE FILM DISTRIBUTION (U.S. CLS. 100, 101 AND 107).

DOMINIC FATHY, EXAMINING ATTORNEY

**CLASS 41—(Continued).**

SN 85-036,993. TABLE TENNIS NATION, LLC, CHAPPAQUA, NY. FILED 5-12-2010.

**REISMAN CUP**

THE MARK CONSISTS OF STANDARD CHARACTERS WITHOUT CLAIM TO ANY PARTICULAR FONT, STYLE, SIZE, OR COLOR.

NO CLAIM IS MADE TO THE EXCLUSIVE RIGHT TO USE "CUP", APART FROM THE MARK AS SHOWN.

FOR ENTERTAINMENT SERVICES, NAMELY, PRODUCING AN ONGOING TELEVISION PROGRAM IN THE FIELD OF TABLE TENNIS; ENTERTAINMENT SERVICES IN THE NATURE OF LIVE PERFORMANCES IN THE NATURE OF TABLE TENNIS TOURNAMENTS; ENTERTAINMENT AND INSTRUCTIONAL SERVICES IN THE NATURE OF CLASSES AND WORKSHOPS IN THE FIELD OF TABLE TENNIS; ORGANIZING SPORTING AND RECREATIONAL EVENTS IN THE NATURE OF TABLE TENNIS COMPETITIONS; PRODUCTION OF TELEVISION PROGRAMS, MOVIES AND VIDEOS, ALL FEATURING TABLE TENNIS (U.S. CLS. 100, 101 AND 107).

KAREN SEVERSON, EXAMINING ATTORNEY

---

SN 85-037,072. LISIESKY, ROBERT, RED BANK, NJ. FILED 5-12-2010.



NO CLAIM IS MADE TO THE EXCLUSIVE RIGHT TO USE "STUDIOS", APART FROM THE MARK AS SHOWN.

THE NAME(S), PORTRAIT(S), AND/OR SIGNATURE(S) SHOWN IN THE MARK IDENTIFIES ROBERT LISIESKY, WHOSE CONSENT(S) TO REGISTER IS MADE OF RECORD.

THE MARK CONSISTS OF THE WORD "ROMAN", WITH THE "R" WRITTEN IN A LARGER FONT AND THE REST OF THE WORD WRITTEN IN A SMALLER FONT. THE WORD "ROBERT" IS WRITTEN INSIDE OF THE "R" IN A SMALL FONT. THE WORD "STUDIOS" IS WRITTEN UNDER THE WORD "ROMAN" IN A MEDIUM FONT. THE LEGS FROM THE "R" IN THE WORD "ROMAN" ARE AFTER THE "T" IN THE WORD "STUDIO" AND BEFORE THE "D" IN THE WORD "STUDIO".

FOR BOOK PUBLISHING; PHOTOGRAPHY SERVICES (U.S. CLS. 100, 101 AND 107).

FIRST USE 9-7-2006; IN COMMERCE 9-7-2006.  
INGA ERVIN, EXAMINING ATTORNEY

**CLASS 41—(Continued).**

SN 85-038,176. "GIVE A DAMN!" ENTERPRISES, LLC, METAIRIE, LA. FILED 5-13-2010.

**GIVE A DAMN!**

THE MARK CONSISTS OF STANDARD CHARACTERS WITHOUT CLAIM TO ANY PARTICULAR FONT, STYLE, SIZE, OR COLOR.

FOR ENTERTAINMENT SERVICES, NAMELY, PROVIDING MOTIVATIONAL SPEAKING SERVICES IN THE FIELD OF EMPLOYEE TRAINING, MOTIVATION, AND PRODUCTIVITY; EDUCATIONAL SERVICES, NAMELY, CONDUCTING CLASSES, SEMINARS, CONFERENCES, AND WORKSHOPS IN THE FIELD OF EMPLOYEE TRAINING, MOTIVATION, AND PRODUCTIVITY; EDUCATIONAL SERVICES, NAMELY, TRAINING AND PERSONAL COACHING IN THE FIELD OF EMPLOYEE TRAINING, MOTIVATION, AND PRODUCTIVITY; DEVELOPMENT OF INSTRUCTIONAL MATERIALS FOR OTHERS IN THE FIELD OF EMPLOYEE TRAINING, MOTIVATION, AND PRODUCTIVITY (U.S. CLS. 100, 101 AND 107).

JIM RINGLE, EXAMINING ATTORNEY

---

SN 85-040,137. DELANEY, WILLIAM, DBA TEMAIR ASSOCIATES, ROSEVILLE, CA. AND DELANEY, TARA, DBA TEMAIR ASSOCIATES, ROSEVILLE, CA. FILED 5-17-2010.

**SOCIAL SENSE**

THE MARK CONSISTS OF STANDARD CHARACTERS WITHOUT CLAIM TO ANY PARTICULAR FONT, STYLE, SIZE, OR COLOR.

FOR EDUCATIONAL SERVICES, NAMELY, PROVIDING CLASSES AND SEMINARS IN THE FIELD OF CHILD DEVELOPMENT (U.S. CLS. 100, 101 AND 107).

DANNEAN HETZEL, EXAMINING ATTORNEY

**CLASS 41—(Continued).**

SN 85-040,214. INSTITUTE OF ASIAN CULTURE & DEVELOPMENT, YONGSAN-GU, SEOUL, REPUBLIC OF KOREA, FILED 5-17-2010.

BACK TO JERUSALEM

THE MARK CONSISTS OF STANDARD CHARACTERS WITHOUT CLAIM TO ANY PARTICULAR FONT, STYLE, SIZE, OR COLOR.

FOR BOARDING SCHOOLS, TEACHING, EDUCATIONAL EXAMINATION, EDUCATIONAL INSTRUCTION ALL IN THE FIELD OF RELIGION; SEMINARS IN THE FIELD OF RELIGION; ENTERTAINMENT AND EDUCATIONAL SERVICES, NAMELY, THE PRESENTATION OF SEMINARS, LECTURES, WORKSHOPS AND PANEL DISCUSSIONS, AND ONGOING TELEVISION AND RADIO TALK SHOWS ALL IN THE FIELD OF PUBLIC INTEREST CONCERNING RELIGION; MANAGEMENT OF MUSIC HALLS, HISTORICAL SPOTS, READING ROOMS, SCIENCE AND OTHER MUSEUMS, NAMELY, MUSIC HALLS, LIBRARIES, MUSEUMS, AND EXHIBITING TO THE PUBLIC HISTORIC SITES; BOOKING OF SEATS FOR SHOWS AND THEATER; PRESENTATION OF LIVE SHOW PERFORMANCES; ENTERTAINMENT SERVICES, NAMELY, LIVE, TELEVISED AND MOVIE APPEARANCES BY A PROFESSIONAL ENTERTAINER; PRODUCTION OF SOUND RECORDINGS, FILM, RADIO, TELEVISION AND LIVE SHOWS; ORGANIZING CULTURAL AND ARTS EVENTS; PROVIDING FACILITIES FOR MOVIES, SHOWS, PLAYS, MUSIC OR EDUCATIONAL TRAINING; PROVIDING ONLINE NON-DOWNLOADABLE ELECTRONIC PUBLICATIONS IN THE NATURE OF BOOKS, NEWSLETTERS, MAGAZINES AND PAMPHLETS IN THE FIELD OF RELIGION; PUBLICATION OF BOOKS AND TEXTS; RENTAL SERVICES FOR AUDIO AND VISUAL EQUIPMENT, RENTAL OF SHOW AND STAGE SCENERY; COMPOSITION OF MUSIC FOR OTHERS; PREPARING SUBTITLES FOR MOVIES; TECHNICAL INSTRUCTION IN THE FIELDS OF AFForestation, AGRICULTURE, FISHERY, AND ANIMAL HUSBANDRY; EDUCATIONAL AND ENTERTAINMENT SERVICES, NAMELY, PRODUCTION OF TELEVISION PROGRAMS; ENTERTAINMENT INFORMATION SERVICES, NAMELY, PROVIDING INFORMATION AND NEWS RELEASES; MODELING FOR ARTISTS (U.S. CLS. 100, 101 AND 107).

MARK PILARO, EXAMINING ATTORNEY

**CLASS 41—(Continued).**

SN 85-042,716. WILLIAM H. WHITAKER, II, DBA CBA1; THE CHURCH BUSINESS ADMINISTRATION NETWORK, RICHMOND, VA. FILED 5-19-2010.



NO CLAIM IS MADE TO THE EXCLUSIVE RIGHT TO USE "CHURCH BUSINESS ADMINISTRATION NETWORK", APART FROM THE MARK AS SHOWN.

THE COLOR(S) BLACK, SILVER, GREY, LIGHT GREY, DARK GREY AND WHITE IS/ARE CLAIMED AS A FEATURE OF THE MARK.

THE MARK CONSISTS OF THREE CONTIGUOUS CUBES IN THE COLORS GREY, LIGHT GREY, DARK GREY AND WHITE. THE LETTERS "CBA1" IS DISPLAYED UNDER THE CUBES IN WHITE, SILVER, LIGHT GREY, GREY AND BLACK LETTERS AGAINST A GREY BACKGROUND WITH THE COLORS DISPLAYED IN A GRADIENT FROM LIGHT TO DARK COLORS. THE WORDING "CHURCH BUSINESS ADMINISTRATION NETWORK" IS DISPLAYED BELOW THE LETTER "CBA1" IN DARK GREY LETTERS. THE WHITE BACKGROUND IS NOT A PART OF THE MARK.

FOR EDUCATION SERVICES, NAMELY, PROVIDING LIVE AND ON-LINE CLASSES, SEMINARS, WORKSHOPS, AND RETREATS IN THE FIELD OF CHURCH BUSINESS ADMINISTRATION CONSISTING OF LAY LEADERSHIP TRAINING, STAFF TRAINING, STEWARDSHIP AND FINANCE LESSONS, AND FACILITY MANAGEMENT LESSONS; EDUCATION SERVICES, NAMELY, PROVIDING CLASSES, SEMINARS, WORKSHOPS, AND RETREATS IN THE FIELD OF CHURCH BUSINESS ADMINISTRATION CONSISTING OF LAY LEADERSHIP TRAINING, STAFF TRAINING, STEWARDSHIP AND FINANCE LESSONS, AND FACILITY MANAGEMENT LESSONS; EDUCATIONAL SERVICES, NAMELY, PROVIDING ON-LINE CLASSES, SEMINARS, WORKSHOPS, AND RETREATS IN THE FIELD OF CHURCH BUSINESS ADMINISTRATION CONSISTING OF LAY LEADERSHIP TRAINING, STAFF TRAINING, STEWARDSHIP AND FINANCE LESSONS, AND FACILITY MANAGEMENT LESSONS (U.S. CLS. 100, 101 AND 107).

FIRST USE 10-1-2009; IN COMMERCE 10-1-2009.  
RENEE SERVANCE, EXAMINING ATTORNEY

**CLASS 41—(Continued).**

SN 85-042,763. WILLIAM H. WHITAKER, II, DBA CBA1; THE CHURCH BUSINESS ADMINISTRATION NETWORK, RICHMOND, VA. FILED 5-19-2010.

## WhitNotes

THE MARK CONSISTS OF STANDARD CHARACTERS WITHOUT CLAIM TO ANY PARTICULAR FONT, STYLE, SIZE, OR COLOR.

FOR EDUCATION SERVICES, NAMELY, PROVIDING LIVE AND ON-LINE CLASSES, SEMINARS, WORKSHOPS, AND RETREATS IN THE FIELD OF CHURCH BUSINESS ADMINISTRATION CONSISTING OF LAY LEADERSHIP TRAINING, STAFF TRAINING, STEWARDSHIP AND FINANCE LESSONS, AND FACILITY MANAGEMENT LESSONS; EDUCATION SERVICES, NAMELY, PROVIDING CLASSES, SEMINARS, WORKSHOPS, AND RETREATS IN THE FIELD OF CHURCH BUSINESS ADMINISTRATION CONSISTING OF LAY LEADERSHIP TRAINING, STAFF TRAINING, STEWARDSHIP AND FINANCE LESSONS, AND FACILITY MANAGEMENT LESSONS; EDUCATIONAL SERVICES, NAMELY, PROVIDING ON-LINE CLASSES, SEMINARS, WORKSHOPS, AND RETREATS IN THE FIELD OF CHURCH BUSINESS ADMINISTRATION CONSISTING OF LAY LEADERSHIP TRAINING, STAFF TRAINING, STEWARDSHIP AND FINANCE LESSONS, AND FACILITY MANAGEMENT LESSONS (U.S. CLS. 100, 101 AND 107).

FIRST USE 10-10-2009; IN COMMERCE 10-10-2009.  
RENEE SERVANCE, EXAMINING ATTORNEY

**CLASS 41—(Continued).**

SN 85-044,804. FERRARI CLUB OF AMERICA, INC., ATLANTA, GA. FILED 5-21-2010.

## The FCA Coppa Bella Macchina Award

THE MARK CONSISTS OF STANDARD CHARACTERS WITHOUT CLAIM TO ANY PARTICULAR FONT, STYLE, SIZE, OR COLOR.

NO CLAIM IS MADE TO THE EXCLUSIVE RIGHT TO USE "COPPA" AND "MACCHINA AWARD", APART FROM THE MARK AS SHOWN.

THE ENGLISH TRANSLATION OF "COPPA BELLA MACCHINA" IN THE MARK IS "BEAUTIFUL MACHINE CUP".

FOR ENTERTAINMENT AND EDUCATION SERVICES, NAMELY, PROVIDING RECOGNITION AND INCENTIVES BY WAY OF AWARDS TO AUTOMOBILE OWNERS WHO DEMONSTRATE IN A ROAD TEST CERTAIN AUTOMOBILES WHICH HAVE BEEN JUDGED TO BE IN THE SAME WORKING ORDER AS WHEN MANUFACTURED (U.S. CLS. 100, 101 AND 107).  
FIRST USE 7-1-1997; IN COMMERCE 7-1-1997.

ASMAT KHAN, EXAMINING ATTORNEY

SN 85-042,790. WILLIAM H. WHITAKER, II, DBA CBA1; THE CHURCH BUSINESS ADMINISTRATION NETWORK, RICHMOND, VA. FILED 5-19-2010.

## Dr. Whit

THE MARK CONSISTS OF STANDARD CHARACTERS WITHOUT CLAIM TO ANY PARTICULAR FONT, STYLE, SIZE, OR COLOR.

FOR EDUCATION SERVICES, NAMELY, PROVIDING LIVE AND ON-LINE CLASSES, SEMINARS, WORKSHOPS, AND RETREATS IN THE FIELD OF CHURCH BUSINESS ADMINISTRATION CONSISTING OF LAY LEADERSHIP TRAINING, STAFF TRAINING, STEWARDSHIP AND FINANCE LESSONS, AND FACILITY MANAGEMENT LESSONS; EDUCATION SERVICES, NAMELY, PROVIDING CLASSES, SEMINARS, WORKSHOPS, AND RETREATS IN THE FIELD OF CHURCH BUSINESS ADMINISTRATION CONSISTING OF LAY LEADERSHIP TRAINING, STAFF TRAINING, STEWARDSHIP AND FINANCE LESSONS, AND FACILITY MANAGEMENT LESSONS; EDUCATIONAL SERVICES, NAMELY, PROVIDING ON-LINE CLASSES, SEMINARS, WORKSHOPS, AND RETREATS IN THE FIELD OF CHURCH BUSINESS ADMINISTRATION CONSISTING OF LAY LEADERSHIP TRAINING, STAFF TRAINING, STEWARDSHIP AND FINANCE LESSONS, AND FACILITY MANAGEMENT LESSONS (U.S. CLS. 100, 101 AND 107).

FIRST USE 10-10-2009; IN COMMERCE 10-10-2009.  
RENEE SERVANCE, EXAMINING ATTORNEY

SN 85-046,236. THE FERRARI CLUB OF AMERICA, INC., ATLANTA, GA. FILED 5-24-2010.

## The FCA Platino Award

THE MARK CONSISTS OF STANDARD CHARACTERS WITHOUT CLAIM TO ANY PARTICULAR FONT, STYLE, SIZE, OR COLOR.

NO CLAIM IS MADE TO THE EXCLUSIVE RIGHT TO USE "AWARD", APART FROM THE MARK AS SHOWN.

THE ENGLISH TRANSLATION OF "PLATINO" IN THE MARK IS "PLATINUM".

FOR ENTERTAINMENT AND EDUCATION SERVICES, NAMELY, PROVIDING RECOGNITION AND INCENTIVES BY WAY OF AWARDS TO AUTOMOBILE OWNERS OF CERTAIN AUTOMOBILES WHICH ACHIEVE CERTAIN CRITERIA AFTER JUDGING IN VARIOUS CLASSES OF AUTOMOBILES (U.S. CLS. 100, 101 AND 107).

FIRST USE 7-1-1995; IN COMMERCE 7-1-1995.  
ASMAT KHAN, EXAMINING ATTORNEY

**CLASS 41—(Continued).**

SN 85-048,080. K2 NETWORK, INC., IRVINE, CA. FILED 5-26-2010.

**SONSUZ MACERA**

THE MARK CONSISTS OF STANDARD CHARACTERS WITHOUT CLAIM TO ANY PARTICULAR FONT, STYLE, SIZE, OR COLOR.

THE ENGLISH TRANSLATION OF "SONSUZ MACERA" IN THE MARK IS "ENDLESS ADVENTURE" OR "ETERNAL ADVENTURE".

FOR ENTERTAINMENT SERVICES, NAMELY, PROVIDING COMPETITIVE MULTI-PLAYER, ONLINE COMPUTER GAMES VIA A GLOBAL NETWORK (U.S. CLS. 100, 101 AND 107).

FIRST USE 5-0-2010; IN COMMERCE 5-0-2010.

KHANH LE, EXAMINING ATTORNEY

**CLASS 41—(Continued).**

TION VIA THE INTERNET; CONDUCTING OF CEREMONIES AND EVENTS; ENTERTAINMENT SERVICES, NAMELY, CONDUCTING PARTIES; ORGANIZING RELIGIOUS EVENTS, NAMELY, RELIGIOUS INSTRUCTION SERVICES, AND CULTURAL EVENTS; ORGANIZING EXHIBITIONS AND EVENTS FOR EDUCATIONAL, RELIGIOUS INSTRUCTION, CULTURAL, ARTS AND ENTERTAINMENT PURPOSES; PRODUCTION OF LIVE ENTERTAINMENT PERFORMANCES AND SHOWS; ENTERTAINMENT, NAMELY, LIVE VARIETY, DRAMA AND COMEDY PERFORMANCES FEATURING LIVE AND RECORDED MUSIC; ARRANGING AND CONDUCTING OF CONCERTS AND LIVE MUSIC EVENTS (UNDER SECTION 1(A)); ENTERTAINMENT SERVICES, NAMELY, CONDUCTING ONLINE CONTESTS AND SWEEPSTAKES SERVICES; ENTERTAINMENT, NAMELY, LIVE PERFORMANCES BY MUSICAL BANDS; PRESENTATION OF MUSICAL PERFORMANCE; ARRANGING AND CONDUCTING CONCERTS (UNDER SECTION 1(B)) (U.S. CLS. 100, 101 AND 107).

FIRST USE 11-15-2002; IN COMMERCE 11-15-2002.  
 NAAKWAMA ANKRAH, EXAMINING ATTORNEY

SN 85-052,033. JDUB MUSIC INC., NEW YORK, NY. FILED 6-1-2010.

THE MARK CONSISTS OF THE LETTERS "J", "E", "C", AND "Y" IN A STYLIZED FORMAT WITH THE HEBREW CHARACTER SHIN IN A STYLIZED FORMAT BETWEEN THE "JE", AND "CY".

THE NON-LATIN CHARACTER IN THE MARK TRANSLITERATES TO SHIN AND REPRESENTS THE 21ST LETTER OF THE HEBREW ALPHABET

FOR ON-LINE JOURNALS, NAMELY, BLOGS FEATURING INFORMATION IN THE FIELD OF RELIGIOUS, CULTURAL, ARTS AND EDUCATIONAL MATERIAL; ENTERTAINMENT SERVICES, NAMELY, PROVIDING A WEBSITE FEATURING AUDIO AND AUDIOVISUAL RECORDINGS FEATURING RELIGIOUS MATERIAL, CULTURAL MATERIAL, THE ARTS AND EDUCATIONAL MATERIAL; PROVIDING INFORMATION IN THE FIELDS OF RELIGIOUS INSTRUCTION, CULTURAL EVENTS, THE ARTS AND EDUCATION VIA THE INTERNET; PROVIDING ELECTRONIC PUBLICATIONS IN THE NATURE OF ELECTRONIC MAGAZINES AND ONLINE MAGAZINES RELATING TO THE JEWISH CULTURE, MUSIC AND ENTERTAINMENT; ELECTRONIC PUBLICATION SERVICES, NAMELY, PUBLICATION OF ELECTRONIC MAGAZINES AND ONLINE MAGAZINES; PROVIDING A WEBSITE FEATURING ENTERTAINMENT INFORMATION ON MUSICAL ARTISTS, MUSICAL CONCERT TOURS, EVENTS AND DOWNLOADABLE AND STREAMING AUDIO AND AUDIOVISUAL MUSICAL CONTENT; PROVIDING ENTERTAINMENT INFORMA-

SN 85-054,502. FAFOLIO LLC, PALOS HEIGHTS, IL. FILED 6-4-2010.

THE MARK CONSISTS OF STANDARD CHARACTERS WITHOUT CLAIM TO ANY PARTICULAR FONT, STYLE, SIZE, OR COLOR.

THE WORDING "FAFOLIO" HAS NO MEANING IN A FOREIGN LANGUAGE.

FOR ENTERTAINMENT IN THE NATURE OF ONLINE COMPUTER FANTASY GAMES CONCERNING INVESTMENTS (U.S. CLS. 100, 101 AND 107).

FIRST USE 3-1-2010; IN COMMERCE 3-1-2010.

SAMUEL E. SHARPER JR., EXAMINING ATTORNEY

**CLASS 41—(Continued).**

SN 85-059,545. BOARD OF TRUSTEES, MINNESOTA STATE COLLEGES AND UNIVERSITIES SYSTEM, AKA MNSCU, ST. PAUL, MN. AND MINNESOTA STATE COMMUNITY AND TECHNICAL COLLEGE, AKA M STATE, FERGUS FALLS, MN. FILED 6-10-2010.

## Ready or Not Reading

THE MARK CONSISTS OF STANDARD CHARACTERS WITHOUT CLAIM TO ANY PARTICULAR FONT, STYLE, SIZE, OR COLOR.

NO CLAIM IS MADE TO THE EXCLUSIVE RIGHT TO USE "READING", APART FROM THE MARK AS SHOWN.

FOR EDUCATION SERVICES, NAMELY, PROVIDING ONE-ON-ONE INSTRUCTION THROUGH ONLINE CORRESPONDENCE WITH MIDDLE AND JUNIOR HIGH SCHOOL STUDENTS IN THE FIELD OF READING; EDUCATION SERVICES, NAMELY, PROVIDING INSTRUCTION THROUGH ONLINE CORRESPONDENCE WITH MIDDLE AND JUNIOR HIGH SCHOOL TEACHERS IN THE FIELDS OF STUDENT EXPECTATIONS, ALIGNMENT AND READING (U.S. CLS. 100, 101 AND 107).

FIRST USE 1-5-2008; IN COMMERCE 10-1-2009.  
BRENDAN MCCAULEY, EXAMINING ATTORNEY

---

SN 85-065,102. BROCKHOFF, JR, JOSEPH E., DIAMOND-HEAD, MS. FILED 6-17-2010.

## SUPER 8 HITTING SYSTEM

THE MARK CONSISTS OF STANDARD CHARACTERS WITHOUT CLAIM TO ANY PARTICULAR FONT, STYLE, SIZE, OR COLOR.

NO CLAIM IS MADE TO THE EXCLUSIVE RIGHT TO USE "HITTING SYSTEM", APART FROM THE MARK AS SHOWN.

FOR PROVIDING TRAINING AND ONLINE TRAINING IN THE FIELD OF BASEBALL HITTING (U.S. CLS. 100, 101 AND 107).

FIRST USE 3-1-1995; IN COMMERCE 3-1-1995.  
NELSON SNYDER, EXAMINING ATTORNEY

---

SN 85-066,991. JASON CHEUNG, SEATTLE, WA. FILED 6-19-2010.

## AIRPOCALYPSE

THE MARK CONSISTS OF STANDARD CHARACTERS WITHOUT CLAIM TO ANY PARTICULAR FONT, STYLE, SIZE, OR COLOR.

FOR ENTERTAINMENT SERVICES, NAMELY, LIVE COMEDIC AND MUSICAL PERFORMANCES (U.S. CLS. 100, 101 AND 107).

FIRST USE 1-8-2009; IN COMMERCE 6-4-2009.  
SOPHIA S. KIM, EXAMINING ATTORNEY

**CLASS 41—(Continued).**

SN 85-067,545. SOLIS, STEPHANIE, SANTA CLARA, CA. FILED 6-21-2010.

## The Blues Guitar Extravaganza

THE MARK CONSISTS OF STANDARD CHARACTERS WITHOUT CLAIM TO ANY PARTICULAR FONT, STYLE, SIZE, OR COLOR.

NO CLAIM IS MADE TO THE EXCLUSIVE RIGHT TO USE "BLUES GUITAR", APART FROM THE MARK AS SHOWN.

FOR ENTERTAINMENT SERVICES IN THE NATURE OF LIVE MUSICAL PERFORMANCES (U.S. CLS. 100, 101 AND 107).

FIRST USE 1-1-2000; IN COMMERCE 1-1-2002.  
DEIRDRE ROBERTSON, EXAMINING ATTORNEY

---

SN 85-078,884. HANDI QUILTER, INC., NORTH SALT LAKE, UT. FILED 7-6-2010.



OWNER OF U.S. REG. NOS. 2,920,821, 3,559,066 AND OTHERS.

NO CLAIM IS MADE TO THE EXCLUSIVE RIGHT TO USE "HANDY QUILTER", APART FROM THE MARK AS SHOWN.

THE MARK CONSISTS OF A STYLIZED IMAGE OF A NEEDLE AND THREAD TO THE LEFT OF THE WORDS "HANDI QUILTER", WITH THE THREAD CONTINUING BELOW THE WORDS AS A DASHED LINE.

FOR EDUCATIONAL SERVICES, NAMELY, PROVIDING INFORMATION AND TRAINING IN THE FIELD OF THE HOBBY OF QUILTING (U.S. CLS. 100, 101 AND 107).

FIRST USE 9-30-2005; IN COMMERCE 9-30-2005.  
RONALD AIKENS, EXAMINING ATTORNEY



**CLASS 41—(Continued).**

SN 85-081,331. DISNEY ENTERPRISES, INC., BURBANK, CA. FILED 7-9-2010.

**D23 GREAT DISNEY SCAVENGER  
HUNT**

THE MARK CONSISTS OF STANDARD CHARACTERS WITHOUT CLAIM TO ANY PARTICULAR FONT, STYLE, SIZE, OR COLOR.

OWNER OF U.S. REG. NOS. 826,419, 3,825,617 AND OTHERS.

NO CLAIM IS MADE TO THE EXCLUSIVE RIGHT TO USE "SCAVENGER HUNT", APART FROM THE MARK AS SHOWN.

FOR PRODUCTION, PRESENTATION, DISTRIBUTION, AND RENTAL OF MOTION PICTURE FILMS; PRODUCTION, PRESENTATION, DISTRIBUTION, AND RENTAL OF TELEVISION AND RADIO PROGRAMS; PRODUCTION, PRESENTATION, AND RENTAL OF SOUND AND VISUAL RECORDINGS; PRODUCTION OF LIVE-ACTION AND ANIMATED ENTERTAINMENT SHOWS AND INTERACTIVE PROGRAMS FOR DISTRIBUTION VIA AUDIO AND VISUAL MEDIA, AND ELECTRONIC MEANS; PRODUCTION AND PROVISION OF ENTERTAINMENT NEWS AND ENTERTAINMENT INFORMATION VIA COMMUNICATION AND COMPUTER NETWORKS; PROVIDING ENTERTAINMENT SERVICES VIA A GLOBAL COMMUNICATION NETWORK IN THE NATURE OF ONLINE GAMES AND WEBSITES FEATURING A WIDE VARIETY OF GENERAL INTEREST ENTERTAINMENT INFORMATION RELATING TO MOTION PICTURE FILMS, TELEVISION SHOW PROGRAMS, MUSICAL VIDEOS, RELATED FILM CLIPS, PHOTOGRAPHS, AND OTHER MULTIMEDIA MATERIALS; AMUSEMENT PARK AND THEME PARK SERVICES; EDUCATIONAL AND ENTERTAINMENT SERVICES RENDERED IN OR RELATING TO THEME PARKS, NAMELY, LIVE STAGE SHOWS, LIVE AMUSEMENT PARK SHOWS, LIVE PERFORMANCES BY COSTUMED CHARACTERS, AND PRESENTATION OF LIVE THEATRICAL PERFORMANCES; PRESENTATION OF LIVE STAGE SHOWS; PRESENTATION OF LIVE SHOW PERFORMANCES; THEATER PRODUCTIONS; ENTERTAINER SERVICES, NAMELY, LIVE APPEARANCES BY A PROFESSIONAL ENTERTAINER (U.S. CLS. 100, 101 AND 107).

MARLENE BELL, EXAMINING ATTORNEY

SN 85-083,249. STULLER, JENNIFER, SEATTLE, WA. FILED 7-13-2010.



THE COLOR(S) RED, BEIGE, AND BROWN IS/ARE CLAIMED AS A FEATURE OF THE MARK.

THE MARK CONSISTS OF THE TERM "INK-STAINED AMAZON" IN STYLIZED RED LETTERING; THE WORDING IS SET AGAINST A BACKGROUND COMPRISED OF BEIGE AND BROWN VERTICAL STRIPES.

FOR CUSTOM WRITING SERVICES; WRITTEN TEXT EDITING SERVICES (U.S. CLS. 100, 101 AND 107).

JIM RINGLE, EXAMINING ATTORNEY

**CLASS 41—(Continued).**

SN 85-085,475. NEVER LOOK BACK ENTERTAINMENT, LLC, DBA NEVER LOOK BACK ENTERTAINMENT, LLC, ROSWELL, GA. FILED 7-15-2010.



NO CLAIM IS MADE TO THE EXCLUSIVE RIGHT TO USE "ENTERTAINMENT", APART FROM THE MARK AS SHOWN.

THE MARK CONSISTS OF THE CAPITAL LETTERS "NLB" APPEARING IN THE REAR VIEW MIRROR AND EACH LETTER IS BACKWARDS STARTING FROM RIGHT TO LEFT.

FOR ENTERTAINMENT SERVICES IN THE NATURE OF RECORDING, PRODUCTION AND POST-PRODUCTION SERVICES IN THE FIELDS OF MUSIC (U.S. CLS. 100, 101 AND 107).

FIRST USE 4-14-2010; IN COMMERCE 6-26-2010.

NAAKWAMA ANKRAH, EXAMINING ATTORNEY

SN 85-085,909. SHALOM, TODD, BROOKLYN, NY. FILED 7-15-2010.



THE MARK CONSISTS OF THE WORDING "ELASTIC CITY" IN BLACK IN A STYLIZED FONT WITH A SPACE BETWEEN THE WORDS, AND A DESIGN THAT CONSISTS OF A HORIZONTAL LINE ABOVE EACH WORD AND A HORIZONTAL LINE BELOW EACH WORD.

FOR ENTERTAINMENT IN THE NATURE OF LIVE PERFORMANCES BY ARTISTS (U.S. CLS. 100, 101 AND 107).

FIRST USE 4-20-2010; IN COMMERCE 4-20-2010.

RENEE MCCRAY, EXAMINING ATTORNEY

SN 85-086,653. CORBETT, MICHEAL N, DAVIS, CA. FILED 7-16-2010.

## Civil Allaince Press

THE MARK CONSISTS OF STANDARD CHARACTERS WITHOUT CLAIM TO ANY PARTICULAR FONT, STYLE, SIZE, OR COLOR.

NO CLAIM IS MADE TO THE EXCLUSIVE RIGHT TO USE "PRESS", APART FROM THE MARK AS SHOWN.

FOR BOOK PUBLISHING; PUBLISHING OF ELECTRONIC PUBLICATIONS (U.S. CLS. 100, 101 AND 107).

BRIDGETT SMITH, EXAMINING ATTORNEY

**CLASS 41—(Continued).**

SN 85-090,302. UNION STATION KANSAS CITY, INC., KANSAS CITY, MO. FILED 7-22-2010.

# CITY STAGE

THE MARK CONSISTS OF STANDARD CHARACTERS WITHOUT CLAIM TO ANY PARTICULAR FONT, STYLE, SIZE, OR COLOR.

OWNER OF U.S. REG. NO. 2,380,109.  
SEC. 2(F).

FOR ENTERTAINMENT AND EDUCATIONAL SERVICES, NAMELY, EXHIBITIONS IN THE NATURE OF MAGIC SHOWS, LIVE CHILDREN'S SHOWS, EDUCATIONAL DEMONSTRATIONS, MOVIE THEATERS, CINEMA THEATERS, DISPLAYS AND EXHIBITIONS OF MOTION PICTURES, CONDUCTING THEATRICAL PRODUCTIONS (U.S. CLS. 100, 101 AND 107).

FIRST USE 11-10-1999; IN COMMERCE 11-10-1999.  
BRIAN CALLAGHAN, EXAMINING ATTORNEY

---

SN 85-092,485. MATTYB, LLC, DULUTH, GA. FILED 7-26-2010.

# MattyBRaps

THE MARK CONSISTS OF STANDARD CHARACTERS WITHOUT CLAIM TO ANY PARTICULAR FONT, STYLE, SIZE, OR COLOR.

THE NAME MATTHEW MORRIS IDENTIFIES A LIVING INDIVIDUAL WHOSE CONSENT IS OF RECORD.

FOR ENTERTAINMENT AND EDUCATION SERVICES IN THE NATURE OF LIVE DANCE AND MUSICAL PERFORMANCES; ENTERTAINMENT IN THE NATURE OF LIVE PERFORMANCES BY MUSICAL ARTISTS; ENTERTAINMENT IN THE NATURE OF LIVE STAGE PERFORMANCES IN THE NATURE OF MUSIC, SONGS AND RAP OR LECTURE FOR HIRE IN THE FIELD OF MUSICAL ENTERTAINMENT BY AN INDIVIDUAL; ENTERTAINMENT IN THE NATURE OF VISUAL AND AUDIO PERFORMANCES BY MUSICAL ARTISTS; ENTERTAINMENT IN THE NATURE OF LIVE PERFORMANCES OF MUSIC, SONGS AND RAP; ENTERTAINMENT SERVICES, NAMELY, PERSONAL APPEARANCES BY A MUSICAL ARTIST; ENTERTAINMENT SERVICES, NAMELY, PROVIDING A WEB SITE FEATURING PHOTOGRAPHIC, AUDIO, VIDEO AND PROSE PRESENTATIONS FEATURING PERFORMANCES OF MUSIC, SONGS AND RAP; ENTERTAINMENT SERVICES, NAMELY, PROVIDING NON-DOWNLOADABLE PLAYBACK OF MUSIC VIA GLOBAL COMMUNICATIONS NETWORKS (U.S. CLS. 100, 101 AND 107).

FIRST USE 5-31-2010; IN COMMERCE 5-31-2010.  
REBECCA SMITH, EXAMINING ATTORNEY

**CLASS 41—(Continued).**

SN 85-092,934. TAYLOR BASS, KAREN K., DBA TAYLOR-MADE MEDIA LLC, VALLEY STREAM, NY. FILED 7-26-2010.

# renewed. redefined.

THE MARK CONSISTS OF STANDARD CHARACTERS WITHOUT CLAIM TO ANY PARTICULAR FONT, STYLE, SIZE, OR COLOR.

FOR BUSINESS EDUCATION AND TRAINING SERVICES, NAMELY, DEVELOPING, AND FACILITATING CUSTOMIZED IN-COMPANY LEADERSHIP AND EXECUTIVE DEVELOPMENT PROGRAMS, PROVIDING EXECUTIVE COACHING SERVICES, AND PROVIDING PUBLIC AND IN-COMPANY KEYNOTE PRESENTATIONS TO BUSINESS LEADERS; CHARITABLE SERVICES, NAMELY, PROVIDING VOCATIONAL EDUCATION IN THE FIELDS OF CONSTRUCTION AND FLIGHT TRAINING TO OBTAIN PILOT'S LICENSE, PROVIDING CAREER GUIDANCE, AND PROVIDING GROUP COACHING IN THE FIELD OF LEADERSHIP DEVELOPMENT TO DISADVANTAGED YOUTH; LIFE COACHING SERVICES IN THE FIELD OF MOMMYHOOD, PUBLIC RELATIONS, BRANDING, CAREER REINVENTION; PERSONAL COACHING SERVICES IN THE FIELD OF MOMMYHOOD, PUBLIC RELATIONS, BRANDING, CAREER REINVENTION; PROFESSIONAL COACHING SERVICES IN THE FIELD OF MOMMYHOOD, PUBLIC RELATIONS, BRANDING, CAREER REINVENTION; PROVIDING GROUP COACHING AND LEARNING FORUMS IN THE FIELD OF LEADERSHIP DEVELOPMENT; PROVIDING GROUP COACHING IN THE FIELD OF MOMMYHOOD, PUBLIC RELATIONS, BRANDING, CAREER REINVENTION (U.S. CLS. 100, 101 AND 107).

FIRST USE 7-17-2010; IN COMMERCE 7-19-2010.  
MIDGE BUTLER, EXAMINING ATTORNEY

---

SN 85-095,181. WEALTHCOUNSEL, LLC, MADISON, WI. FILED 7-28-2010.

# TAX CAMP

THE MARK CONSISTS OF STANDARD CHARACTERS WITHOUT CLAIM TO ANY PARTICULAR FONT, STYLE, SIZE, OR COLOR.

NO CLAIM IS MADE TO THE EXCLUSIVE RIGHT TO USE "TAX", APART FROM THE MARK AS SHOWN.

SEC. 2(F).

FOR EDUCATIONAL SERVICES, NAMELY, CONDUCTING COURSES IN THE FIELDS OF TAX AND TAXATION PLANNING, WEALTH PLANNING, ESTATE PLANNING, ESTATE SETTLEMENT AND ESTATE ADMINISTRATION PRACTICE, AND DISTRIBUTION OF TRAINING MATERIALS IN CONNECTION WITH SUCH EDUCATIONAL SERVICES (U.S. CLS. 100, 101 AND 107).

FIRST USE 6-17-1999; IN COMMERCE 6-17-1999.  
NAAKWAMA ANKRAH, EXAMINING ATTORNEY

**CLASS 41—(Continued).**

SN 85-096,119. CALIFORNIA INTERCONTINENTAL UNIVERSITY, INC., DIAMOND BAR, CA. FILED 7-29-2010.

CALUNIVERSITY

THE MARK CONSISTS OF STANDARD CHARACTERS WITHOUT CLAIM TO ANY PARTICULAR FONT, STYLE, SIZE, OR COLOR.

SEC. 2(F).

FOR EDUCATIONAL SERVICES, NAMELY, PROVIDING INNOVATIVE EDUCATIONAL OPPORTUNITIES THROUGH DISTANCE STUDY, CRITICAL RESEARCH AND QUALITY SERVICE TO STUDENTS (U.S. CLS. 100, 101 AND 107).

FIRST USE 3-10-2003; IN COMMERCE 6-1-2004.

HEATHER SAPP, EXAMINING ATTORNEY

**CLASS 41—(Continued).**

SN 85-104,121. MPOWER FOUNDATION, INC., LOUISVILLE, KY. FILED 8-10-2010.



THE COLOR(S) BLACK AND BLUE IS/ARE CLAIMED AS A FEATURE OF THE MARK.

THE MARK CONSISTS OF THE TEXT "MPOWER", ALL IN BLACK LETTERS, WITH THE "M" IN LOWER CASE AND THE WORD "POWER" ALL IN UPPER CASE. ABOVE THE "O" IN "POWER" THERE ARE THREE STACKED AND ASCENDING CURVES IN BLUE. AS EACH CURVE ASCENDS, IT GROWS SLIGHTLY LARGER, GIVING THE EFFECT OF ENERGY OR SOUND WAVES EMITTING FROM THE TOP OF THE "O".

THE WORDING "MPOWER" HAS NO MEANING IN A FOREIGN LANGUAGE.

FOR CHARITABLE SERVICES, NAMELY, PROVIDING TRAINING IN THE FIELDS OF DENTISTRY, MEDICINE AND OPTOMETRY FOR MINISTRIES AND INDIGENOUS CHURCHES (U.S. CLS. 100, 101 AND 107).

FIRST USE 1-1-2009; IN COMMERCE 1-1-2009.

ANGELA M. MICHELI, EXAMINING ATTORNEY

SN 85-096,886. MILLER, MARIANN HYBELS, SANTA MONICA, CA. FILED 7-30-2010.

Sexual Abuse Speaks

THE MARK CONSISTS OF STANDARD CHARACTERS WITHOUT CLAIM TO ANY PARTICULAR FONT, STYLE, SIZE, OR COLOR.

NO CLAIM IS MADE TO THE EXCLUSIVE RIGHT TO USE "SEXUAL ABUSE", APART FROM THE MARK AS SHOWN.

FOR EDUCATIONAL SERVICES, NAMELY, PROVIDING MOTIVATIONAL SPEAKING SERVICES AND CONDUCTING CLASSES, SEMINARS, CONFERENCES AND WORKSHOPS ALL IN THE FIELD OF CHILDHOOD SEXUAL ABUSE AND DISTRIBUTION OF PRINTED MATERIALS IN CONNECTION THEREWITH IN HARD COPY OR ELECTRONIC FORMAT ON THE SAME TOPICS (U.S. CLS. 100, 101 AND 107).

MARY CRAWFORD, EXAMINING ATTORNEY

SN 85-107,192. LASS GLOBAL LLC, DBA THE JEWELRY COACH, AUSTIN, TX. FILED 8-13-2010.



NO CLAIM IS MADE TO THE EXCLUSIVE RIGHT TO USE "JEWELRY COACH" AND "TRAINING", APART FROM THE MARK AS SHOWN.

THE COLOR(S) GREY, ORANGE AND WHITE IS/ARE CLAIMED AS A FEATURE OF THE MARK.

THE MARK CONSISTS OF THE PHRASE "THE JEWELRY COACH" IN GREY OVER THE PHRASE "TRAINING FORWARD" IN ORANGE FOLLOWED BY AN ORANGE OVAL WITH TWO WHITE TRIANGLES POINTING TO THE RIGHT.

FOR EDUCATIONAL SERVICES, NAMELY, DEVELOPING AND CONDUCTING TRAINING COURSES AND DISTRIBUTION OF TRAINING MATERIALS IN CONNECTION THEREWITH FOR SUBJECT MATTERS AS REQUESTED BY CUSTOMERS (U.S. CLS. 100, 101 AND 107).

FIRST USE 12-4-2009; IN COMMERCE 5-4-2010.

EDWARD FENNESSY, EXAMINING ATTORNEY

**CLASS 41—(Continued).**

SN 85-111,217. MIRAULA, NICOLE, HUNTINGTON BEACH, CA. FILED 8-19-2010.

**NICOLE ALYSSA MIRAULA**

THE MARK CONSISTS OF STANDARD CHARACTERS WITHOUT CLAIM TO ANY PARTICULAR FONT, STYLE, SIZE, OR COLOR.

THE MARK IDENTIFIES A LIVING INDIVIDUAL WHOSE CONSENT IS OF RECORD.

FOR ENTERTAINMENT IN THE NATURE OF LIVE PERFORMANCES AND PERSONAL APPEARANCES BY AN ACTRESS (U.S. CLS. 100, 101 AND 107).

FLORENTINA BLANDU, EXAMINING ATTORNEY

SN 85-111,287. STEP EVOLUTION LLC, CAMAS, WA. FILED 8-19-2010.

**RERAVE**

THE MARK CONSISTS OF STANDARD CHARACTERS WITHOUT CLAIM TO ANY PARTICULAR FONT, STYLE, SIZE, OR COLOR.

FOR ENTERTAINMENT SERVICES, NAMELY, PROVIDING TEMPORARY USE OF NON-DOWNLOADABLE INTERACTIVE MULTIPLAYER GAMES PLAYED OVER COMPUTER NETWORKS AND GLOBAL COMMUNICATIONS NETWORKS; PROVIDING TEMPORARY USE OF NON-DOWNLOADABLE COMPUTER GAMES AND VIDEO GAMES OVER COMPUTER NETWORKS AND GLOBAL COMMUNICATIONS NETWORKS; ARRANGING AND CONDUCTING COMPETITIONS FOR VIDEO GAME PLAYERS AND COMPUTER GAME PLAYERS; PROVIDING ENTERTAINMENT INFORMATION ON THE VIDEO GAME AND COMPUTER GAME INDUSTRIES VIA THE INTERNET; AND PROVIDING INFORMATION ON COMPUTER GAMES, VIDEO GAMES, VIDEO GAME CONSOLES AND ACCESSORIES THEREOF FOR ENTERTAINMENT PURPOSES VIA THE INTERNET (U.S. CLS. 100, 101 AND 107).

ANDREA K. NADELMAN, EXAMINING ATTORNEY

**CLASS 41—(Continued).**

SN 85-112,478. ORTHOWORLD, INC., CHAGRIN FALLS, OH. FILED 8-20-2010.

**ORTHOBIOCEUTICALS NOW**

THE MARK CONSISTS OF STANDARD CHARACTERS WITHOUT CLAIM TO ANY PARTICULAR FONT, STYLE, SIZE, OR COLOR.

OWNER OF U.S. REG. NOS. 2,435,191, 3,575,463 AND OTHERS.

NO CLAIM IS MADE TO THE EXCLUSIVE RIGHT TO USE "ORTHOBIOCEUTICALS", APART FROM THE MARK AS SHOWN.

FOR ONLINE PUBLICATION, NAMELY, BROCHURES, BOOKLETS, NEWSLETTERS AND ARTICLES IN THE FIELD OF THERAPEUTIC SOLUTIONS TO MUSCULOSKELETAL CONDITIONS (U.S. CLS. 100, 101 AND 107).

MICHELE SWAIN, EXAMINING ATTORNEY

SN 85-114,419. TRAFFIC SPORTS USA, INC., MIAMI, FL. FILED 8-24-2010.



NO CLAIM IS MADE TO THE EXCLUSIVE RIGHT TO USE "AMERICA" AND THE REPRESENTATION OF THE MAP OF NORTH AND SOUTH AMERICA, APART FROM THE MARK AS SHOWN.

THE STIPPLING IS FOR SHADING PURPOSES ONLY.

THE MARK CONSISTS OF A MAP OF THE WESTERN HEMISPHERE ON A SOCCER BALL; THE SOCCER BALL IS SURROUNDED BY A CIRCULAR BORDER CONSISTING OF A LIGHTER CIRCLE ON THE INSIDE OF THE BORDER, A LIGHTER CIRCLE ON THE OUTSIDE OF THE BORDER, AND DARKER INTERIOR CIRCLE. THE WORDS "COPITA AMERICA" ARE ON THE TOP OF THE INTERIOR CIRCLE, ONE STAR APPEARS ON THE LEFT SIDE OF THE INTERIOR CIRCLE AND ONE STAR APPEARS ON THE RIGHT SIDE OF THE INTERIOR CIRCLE.

FOR ORGANIZING, CONDUCTING, AND STAGING PROFESSIONAL SOCCER GAMES AND EXHIBITIONS; PROVIDING A WEBSITE FEATURING SOCCER AND SOCCER-RELATED INFORMATION (U.S. CLS. 100, 101 AND 107).

AMY ALFIERI, EXAMINING ATTORNEY

**CLASS 41—(Continued).**

SN 85-117,948. CASTLE MEDIA GROUP, INC., TEMPE, AZ.  
FILED 8-27-2010.

## Sexually Speaking

THE MARK CONSISTS OF STANDARD CHARACTERS WITHOUT CLAIM TO ANY PARTICULAR FONT, STYLE, SIZE, OR COLOR.

NO CLAIM IS MADE TO THE EXCLUSIVE RIGHT TO USE "SEXUALLY", APART FROM THE MARK AS SHOWN.

FOR EDUCATION AND ENTERTAINMENT SERVICES, NAMELY, PROVIDING PERSONAL SEXUAL COACHING SERVICES, CLASSES, SEMINARS, CONFERENCES, WORKSHOPS, WEBINARS, VIDEO PODCASTS, ONGOING RADIO PROGRAMS AND RADIO TALK SHOWS IN THE FIELDS OF DATING, SEXUAL COMPATIBILITY, SEXUAL RELATIONSHIPS, PERSONAL SEXUAL IMPROVEMENT, SEXUAL SELF-DEVELOPMENT, AND SELF-AWARENESS (U.S. CLS. 100, 101 AND 107).

FIRST USE 8-10-2010; IN COMMERCE 8-18-2010.  
TIMOTHY FINNEGAN, EXAMINING ATTORNEY

---

SN 85-122,755. LABORATORY INSTITUTE OF MERCHANDISING, NEW YORK, NY. FILED 9-3-2010.

## LIM OPTIONS

THE MARK CONSISTS OF STANDARD CHARACTERS WITHOUT CLAIM TO ANY PARTICULAR FONT, STYLE, SIZE, OR COLOR.

OWNER OF U.S. REG. NOS. 2,410,462, 3,729,588 AND 3,881,085.

FOR EDUCATIONAL SERVICES, NAMELY, PROVIDING PROFESSIONAL DEVELOPMENT COURSES, CONTINUING EDUCATION COURSES, WORKSHOPS AND SEMINARS, ALL IN THE FIELD OF FASHION (U.S. CLS. 100, 101 AND 107).

DEBRA LEE, EXAMINING ATTORNEY

---

SN 85-124,087. WHITING BURGESS, LLC, MYSTIC, CT.  
FILED 9-7-2010.

## TennisIdentity

THE MARK CONSISTS OF STANDARD CHARACTERS WITHOUT CLAIM TO ANY PARTICULAR FONT, STYLE, SIZE, OR COLOR.

FOR ON-LINE JOURNALS, NAMELY, BLOGS FEATURING TRENDS IN THE TENNIS SPORT INDUSTRY (U.S. CLS. 100, 101 AND 107).

FIRST USE 1-1-2008; IN COMMERCE 1-1-2008.  
BILL DAWE, EXAMINING ATTORNEY

**CLASS 41—(Continued).**

SN 85-127,401. CLARO, PETER, GRANITE SPRINGS, NY.  
FILED 9-10-2010.

## ROADSIDE POETS

THE MARK CONSISTS OF STANDARD CHARACTERS WITHOUT CLAIM TO ANY PARTICULAR FONT, STYLE, SIZE, OR COLOR.

NO CLAIM IS MADE TO THE EXCLUSIVE RIGHT TO USE "POETS", APART FROM THE MARK AS SHOWN.

FOR ENTERTAINMENT SERVICES IN THE NATURE OF LIVE MUSICAL PERFORMANCES (U.S. CLS. 100, 101 AND 107).

KATINA MISTER, EXAMINING ATTORNEY

---

SN 85-128,520. THE NATIONAL ARBOR DAY FOUNDATION, AKA THE ARBOR DAY FOUNDATION, LINCOLN, NE. FILED 9-13-2010.



OWNER OF U.S. REG. NO. 2,893,264.

THE COLOR(S) GOLD, GREEN, AND WHITE IS/ARE CLAIMED AS A FEATURE OF THE MARK.

THE MARK CONSISTS OF A GOLD CIRCLE WITH THREE WHITE CHEVRONS IMPOSED OVER IT, ONE ON TOP OF THE OTHER. TO THE RIGHT OF THE CIRCLE IS THE WORD "ARBORLINKS" IN SMALL CASE GREEN LETTERS EXCEPT FOR THE "A" AND "L" WHICH ARE CAPITALIZED.

FOR ENTERTAINMENT IN THE NATURE OF GOLF TOURNAMENTS; GOLF CLUB SERVICES; GOLF COURSES; ORGANISATION OF GOLF TOURNAMENTS (U.S. CLS. 100, 101 AND 107).

FIRST USE 4-1-2001; IN COMMERCE 4-1-2001.

MATTHEW MCDOWELL, EXAMINING ATTORNEY

**CLASS 41—(Continued).**

SN 85-129,199. UNIVERSIDAD INTERAMERICANA DE PUERTO RICO, INC., SAN JUAN, PUERTO RICO, FILED 9-14-2010.



THE MARK CONSISTS OF A STYLIZED "U" WITH A DOT ABOVE THE CENTER, CREATING THE APPEARANCE OF AN "I".

FOR EDUCATIONAL SERVICES, NAMELY, CONDUCTING CLASSES, SEMINARS AND CONFERENCES, AND PROVIDING INSTRUCTION AND TEACHING ALL AT THE UNDERGRADUATE AND GRADUATE LEVEL; ENTERTAINMENT SERVICES, NAMELY, PROVIDING DANCE, MUSIC, THEATER AND VISUAL ARTS EXHIBITIONS, CONDUCTING CLASSES AND COMPETITIONS IN SPORTS; PROVIDING AN ONLINE PERIODIC MAGAZINE FEATURING CONTENT ON COLLEGE ADMISSIONS, LIFESTYLE AND ADVICE FOR COLLEGE STUDENTS, PROSPECTIVE COLLEGE STUDENTS AND THE PARENTS OF COLLEGE OR PROSPECTIVE COLLEGE STUDENTS (U.S. CLS. 100, 101 AND 107).

FIRST USE 12-0-1993; IN COMMERCE 12-0-1993.  
KRISTIN DAHLING, EXAMINING ATTORNEY

SN 85-133,299. THE NATIONAL THEATRE FOR CHILDREN, INC., MINNEAPOLIS, MN. FILED 9-20-2010.

M@D ABOUT

THE MARK CONSISTS OF STANDARD CHARACTERS WITHOUT CLAIM TO ANY PARTICULAR FONT, STYLE, SIZE, OR COLOR.

FOR EDUCATIONAL ENTERTAINMENT SERVICES, NAMELY, A CONTINUING PROGRAM ABOUT EXPLORING TOPICS IMPORTANT TO CHILDREN AND THEIR FAMILIES ACCESSIBLE BY LIVE THEATRE, TELEVISION, SATELLITE, AUDIO, MEDIA AND COMPUTER NETWORKS AND WEBSITES (U.S. CLS. 100, 101 AND 107).

FIRST USE 6-14-2010; IN COMMERCE 6-14-2010.  
HENRY S. ZAK, EXAMINING ATTORNEY

**CLASS 41—(Continued).**

SN 85-134,069. DEREK BURNS, PACIFICA, CA. FILED 9-20-2010.

knives and fire

THE MARK CONSISTS OF STANDARD CHARACTERS WITHOUT CLAIM TO ANY PARTICULAR FONT, STYLE, SIZE, OR COLOR.

FOR ON-LINE JOURNALS, NAMELY, BLOGS FEATURING INFORMATION REGARDING CULINARY ARTS; ENTERTAINMENT IN THE NATURE OF A FOOD AND CULINARY SHOW; ENTERTAINMENT, NAMELY, A CONTINUING FOOD AND CULINARY SHOW BROADCAST OVER TELEVISION, SATELLITE, AUDIO, INTERNET, AND VIDEO MEDIA; ENTERTAINMENT SERVICES, NAMELY, PROVIDING A WEB SITE FEATURING PHOTOGRAPHIC, AUDIO AND VIDEO PRESENTATIONS FEATURING FOOD AND CULINARY PRESENTATIONS; EDUCATIONAL SERVICES, NAMELY, PROVIDING CLASSES AND WORKSHOPS IN THE FIELD OF CULINARY ARTS; SPECIAL EVENT PLANNING FOR SOCIAL ENTERTAINMENT RELATED TO CULINARY ARTS (U.S. CLS. 100, 101 AND 107).

NAKIA HENRY, EXAMINING ATTORNEY

SN 85-134,476. THE ELEVATE INSTITUTE INTERNATIONAL, LLC, LAS VEGAS, NV. FILED 9-21-2010.

study excellence

THE MARK CONSISTS OF STANDARD CHARACTERS WITHOUT CLAIM TO ANY PARTICULAR FONT, STYLE, SIZE, OR COLOR.

NO CLAIM IS MADE TO THE EXCLUSIVE RIGHT TO USE "STUDY", APART FROM THE MARK AS SHOWN.

FOR EDUCATIONAL SERVICES, NAMELY, CONDUCTING DISTANCE LEARNING INSTRUCTION AT THE SECONDARY, COLLEGE AND GRADUATE LEVELS (U.S. CLS. 100, 101 AND 107).

FIRST USE 8-1-2010; IN COMMERCE 8-1-2010.  
LINDA ORNDORFF, EXAMINING ATTORNEY

**CLASS 41—(Continued).**

SN 85-135,961. WIEGERS, FRANK, SANTA MONICA, CA. FILED 9-22-2010.



NO CLAIM IS MADE TO THE EXCLUSIVE RIGHT TO USE "FOR SIZZLING SEX AND LASTING RELATIONSHIPS", APART FROM THE MARK AS SHOWN.

THE COLOR(S) BLACK, GREY AND RED IS/ARE CLAIMED AS A FEATURE OF THE MARK.

THE MARK CONSISTS OF THE FOLLOWING: THE WORDS "TOP GUN" IN BLACK FADING TO GREY FONT AND THE WORD "LOVE" IN A STYLIZED RED FONT, WITH A LINE IN BLACK WHICH FADES TO GREY CONNECTING AN AIRPLANE OVER THE WORDS "FOR SIZZLING SEX AND LASTING RELATIONSHIPS" IN BLACK.

FOR EDUCATIONAL SERVICES, NAMELY, CONDUCTING SEMINARS, LECTURES, TELESEMINARS, TELECLASSES, AND WORKSHOPS IN PERSONAL AWARENESS (U.S. CLS. 100, 101 AND 107).

FIRST USE 5-3-2010; IN COMMERCE 5-3-2010.

ALEXANDER L. POWERS, EXAMINING ATTORNEY

---

SN 85-136,826. CREATIVE CAREER ACADEMY, DBA CREATIVE CAREER ACADEMY K - 12, ROSWELL, GA. FILED 9-23-2010.



NO CLAIM IS MADE TO THE EXCLUSIVE RIGHT TO USE "CREATIVE CAREER ACADEMY K-12", APART FROM THE MARK AS SHOWN.

THE COLOR(S) GOLD, YELLOW, LIGHT BLUE, BLACK, WHITE, AND GREY ARE CLAIMED AS A FEATURE OF THE MARK. IS/ARE CLAIMED AS A FEATURE OF THE MARK.

THE MARK CONSISTS OF THE APPLICANT'S SCHOOL SEAL THAT IS A CIRCLE SHAPE DESIGN IN GOLD GRADIENT COLOR, A RIBBON IN YELLOW ON THE BOTTOM OF CIRCLE DESIGN THAT STATES "PURSUE YOUR CAREER AT ANY AGE" IN LIGHT BLUE. A WINGED SHAPE DESIGN IN GOLD GRADIENT OUTLINED IN BLUE AND HAS A BLACK OUTLINE OF AN EAGLE FACE IN THE MIDDLE. CIRCLE DESIGN HAS A LIGHT BLUE BACKGROUND AND THE WORDS "CREATIVE" IN WHITE OUTLINED IN BLACK, AND "CAREER ACADEMY" IN WHITE. "K-12" APPEARS IN GREY IN THE MIDDLE OF THE MARK.

FOR EDUCATION IN THE FIELD OF ANIMATION, VIDEO GAME DESIGN, FASHION DESIGN, DIGITAL FILM, IT, COMPUTER SCIENCE, ART DESIGN ON THE COMPUTER RENDERED THROUGH CORRESPONDENCE COURSES (U.S. CLS. 100, 101 AND 107).

FIRST USE 9-19-2010; IN COMMERCE 9-19-2010.

ROSELLE HERRERA, EXAMINING ATTORNEY

**CLASS 41—(Continued).**

SN 85-137,780. ALDRICH, BRETT, AMITY, OR. FILED 9-24-2010.

## Jet Black Productions

THE MARK CONSISTS OF STANDARD CHARACTERS WITHOUT CLAIM TO ANY PARTICULAR FONT, STYLE, SIZE, OR COLOR.

NO CLAIM IS MADE TO THE EXCLUSIVE RIGHT TO USE "PRODUCTIONS", APART FROM THE MARK AS SHOWN.

FOR ENTERTAINMENT MEDIA PRODUCTION SERVICES FOR MOTION PICTURES, TELEVISION AND INTERNET (U.S. CLS. 100, 101 AND 107).

KELLY TRUSILO, EXAMINING ATTORNEY

---

SN 85-139,858. THE WISE DC, INC., BRIDGETON, NJ. FILED 9-28-2010.

## The Wise DC

THE MARK CONSISTS OF STANDARD CHARACTERS WITHOUT CLAIM TO ANY PARTICULAR FONT, STYLE, SIZE, OR COLOR.

NO CLAIM IS MADE TO THE EXCLUSIVE RIGHT TO USE "DC", APART FROM THE MARK AS SHOWN.

FOR CONTINUING EDUCATION SERVICES, NAMELY, PROVIDING LIVE AND ON-LINE CONTINUING PROFESSIONAL EDUCATION SEMINARS IN THE FIELD OF CHIROPRACTIC (U.S. CLS. 100, 101 AND 107).

FIRST USE 9-15-2010; IN COMMERCE 9-15-2010.

DAVID C. REIHNER, EXAMINING ATTORNEY

**CLASS 41—(Continued).**

SN 85-139,943. THE WISE DC, INC., BRIDGETON, NJ. FILED 9-28-2010.



NO CLAIM IS MADE TO THE EXCLUSIVE RIGHT TO USE DC, ANATOMY, NUTRITION, AND X-RAY FUNDAMENTALS, APART FROM THE MARK AS SHOWN.

THE COLOR(S) BLACK, WHITE, GREEN, BLUE, GOLD, ORANGE, AND BEIGE IS/ARE CLAIMED AS A FEATURE OF THE MARK.

THE MARK CONSISTS OF THE WORDING "THE WISE DC" IN AN ARC DISPLAYED IN LIGHT BLUE OUTLINED IN DARK BLUE; AN OWL DEPICTED IN SHADES OF LIGHT AND DARK BLUE AND GOLD OUTLINED IN DARK BLUE WITH BLACK AND GOLD EYES AND BLACK TALONS; A GRADUATION CAP THAT IS DARK BLUE; GREEN, BEIGE, AND ORANGE BOOKS WITH WHITE PAGES AND WHITE WORDING "ANATOMY" "NUTRITION" AND "X-RAY FUNDAMENTALS"; A WHITE PAPER DOCUMENT AND A WHITE FEATHER PEN TIPPED IN GOLD; AND BLACK SHADOW OF THE OWL.

FOR CONTINUING EDUCATION SERVICES, NAMELY, PROVIDING LIVE AND ON-LINE CONTINUING PROFESSIONAL EDUCATION SEMINARS IN THE FIELD OF CHIROPRACTIC (U.S. CLS. 100, 101 AND 107).

FIRST USE 9-15-2010; IN COMMERCE 9-15-2010.  
DAVID C. REIHNER, EXAMINING ATTORNEY

SN 85-140,435. PRETTY FLUFFY CHICKEN PRODUCTIONS, LLC, EDINA, MN. FILED 9-28-2010.

**EAT YOUR DRINK**

THE MARK CONSISTS OF STANDARD CHARACTERS WITHOUT CLAIM TO ANY PARTICULAR FONT, STYLE, SIZE, OR COLOR.

NO CLAIM IS MADE TO THE EXCLUSIVE RIGHT TO USE "DRINK", APART FROM THE MARK AS SHOWN.

FOR ON-LINE JOURNALS, NAMELY, BLOGS FEATURING RECIPES, ENTERTAINING, COCKTAILS, COCKTAIL RECIPES, PHOTOS, AND MENU PLANNING (U.S. CLS. 100, 101 AND 107).

WON TEAK OH, EXAMINING ATTORNEY

**CLASS 41—(Continued).**

SN 85-141,183. WHITE, PHILIP, PHOENIX, AZ. FILED 9-29-2010.

**OKALA**

THE MARK CONSISTS OF STANDARD CHARACTERS WITHOUT CLAIM TO ANY PARTICULAR FONT, STYLE, SIZE, OR COLOR.

SEC. 2(F).

FOR EDUCATIONAL SERVICES, NAMELY, PROVIDING WORKSHOPS AND SEMINARS IN THE FIELDS OF COMMERCIAL, INDUSTRIAL, MEDICAL AND CONSUMER PRODUCT DEVELOPMENT, DESIGN AND LIFE CYCLE ASSESSMENT, AND THE DISTRIBUTION OF COURSE MATERIALS THEREWITH (U.S. CLS. 100, 101 AND 107).

FIRST USE 3-0-2004; IN COMMERCE 3-0-2004.  
TRACY FLETCHER, EXAMINING ATTORNEY

SN 85-141,625. ROCK'N RIBS BBQ FESTIVAL, SPRINGFIELD, MO. FILED 9-30-2010.



NO CLAIM IS MADE TO THE EXCLUSIVE RIGHT TO USE "BBQ FESTIVAL", APART FROM THE MARK AS SHOWN.

THE COLOR(S) BLACK, RED, BROWN, BEIGE, WHITE, YELLOW, ORANGE, BLUE, AND PINK IS/ARE CLAIMED AS A FEATURE OF THE MARK.

THE MARK CONSISTS OF THE LITERAL ELEMENT "ROCK N RIBS BBQ FESTIVAL" AND A DESIGN ELEMENT COMPRISING A PIG WEARING A COSTUME PLAYING A GUITAR SURROUNDED BY FIRE. THE DESIGN ELEMENT IS ENCLOSED IN CONCENTRIC OVALS. THE COLOR BLACK APPEARS IN THE WORDING "ROCK N RIBS BBQ FESTIVAL", IN THE PIG, AND OUTLINES THE FIRE, GUITAR, AND PIG. THE COLOR RED APPEARS IN THE OUTER OVAL, IN THE FIRE, AND IN THE PIG. THE COLOR BROWN APPEARS IN THE INNER OVAL, IN THE GUITAR, AND OUTLINES THE MARK'S LITERAL ELEMENT. THE COLOR BEIGE APPEARS INSIDE OF THE OVAL. THE COLOR WHITE APPEARS IN THE PIG'S COSTUME. THE COLOR YELLOW APPEARS IN THE PIG'S COSTUME AND IN THE FIRE. THE COLOR ORANGE APPEARS IN THE FIRE. THE COLOR BLUE APPEARS IN THE PIG'S SHOES. THE COLOR PINK APPEARS IN THE PIG.

FOR ENTERTAINMENT SERVICES, NAMELY, PLANNING AND CONDUCTING A BARBEQUE CONTEST, FOOD AND MUSIC FESTIVAL INCLUDING BOOTHS FEATURING THE GOODS OF OTHERS (U.S. CLS. 100, 101 AND 107).

FIRST USE 4-1-1999; IN COMMERCE 4-1-1999.  
LAURIE KAUFMAN, EXAMINING ATTORNEY



**CLASS 41—(Continued).**

SN 85-142,961. GRANDTEX, LLC, AUSTIN, TX. FILED 10-1-2010.

**Total Frat Move**

THE MARK CONSISTS OF STANDARD CHARACTERS WITHOUT CLAIM TO ANY PARTICULAR FONT, STYLE, SIZE, OR COLOR.

FOR ON-LINE JOURNALS, NAMELY, BLOGS FEATURING COMEDY AND ENTERTAINMENT; ENTERTAINMENT IN THE NATURE OF ON-GOING TELEVISION PROGRAMS IN THE FIELD OF COMEDY, SPORTS, POLITICS, COLLEGE LIFE, FRATERNITY AND SORORITY LIFE, MUSIC, CURRENT EVENTS; PROVIDING A WEBSITE FOR ENTERTAINMENT PURPOSES WHERE USERS CAN VIEW AND POST TEXT MESSAGES, PHOTO, VIDEOS, ARTICLES FEATURING COMEDY, COLLEGE LIFE, FRATERNITY AND SORORITY LIFE, AND GENERAL INTEREST THOUGHTS (U.S. CLS. 100, 101 AND 107).

FIRST USE 6-1-2010; IN COMMERCE 6-1-2010.

TRICIA SONNEBORN, EXAMINING ATTORNEY

**CLASS 41—(Continued).**

SN 85-145,549. SIBB OPERATIONS LLC, AUSTIN, TX. FILED 10-5-2010.

**10/20**

THE MARK CONSISTS OF STANDARD CHARACTERS WITHOUT CLAIM TO ANY PARTICULAR FONT, STYLE, SIZE, OR COLOR.

FOR ENTERTAINMENT IN THE NATURE OF ORGANIZING A SPORTING EVENT IN THE NATURE OF A RUNNING RACE AND RELATED SPORTING AND ENTERTAINMENT EVENTS, NAMELY, ORGANIZING RUNNING EVENT EXPOSITIONS FEATURING VENDOR BOOTHS OF FOOD AND RACE RELATED SPORTING GOODS, LIVE MUSIC PERFORMANCES, AND PLANNING PARTIES AND DINNERS (U.S. CLS. 100, 101 AND 107).

FIRST USE 9-0-2010; IN COMMERCE 9-0-2010.

JENNY PARK, EXAMINING ATTORNEY

SN 85-145,005. TRADITIONAL MARKETING SUCKS, LLC, DBA TRADITIONAL MARKETING SUCKS, LLC, MEMPHIS, TN. FILED 10-5-2010.



NO CLAIM IS MADE TO THE EXCLUSIVE RIGHT TO USE "MARKETING", APART FROM THE MARK AS SHOWN.

THE COLOR(S) BLACK AND RED IS/ARE CLAIMED AS A FEATURE OF THE MARK.

THE MARK CONSISTS OF BLACK "TRADITIONAL MARKETING", RED "SUCKS" SURROUNDED BY A LINE WITH THE WORD ".COM".

FOR EDUCATION SERVICES, NAMELY, PROVIDING ON-LINE TRAINING IN THE FIELD OF MARKETING (U.S. CLS. 100, 101 AND 107).

RONALD MCMORROW, EXAMINING ATTORNEY

SN 85-145,684. JACK STUDIOS INC., NEW YORK, NY. FILED 10-5-2010.

**JACK STUDIOS**

THE MARK CONSISTS OF STANDARD CHARACTERS WITHOUT CLAIM TO ANY PARTICULAR FONT, STYLE, SIZE, OR COLOR.

NO CLAIM IS MADE TO THE EXCLUSIVE RIGHT TO USE "STUDIOS", APART FROM THE MARK AS SHOWN.

FOR DIGITAL IMAGING SERVICES; PROVIDING VISUAL, AUDIO AND VIDEO STUDIOS; RENTAL OF PHOTOGRAPHIC AND FILM STUDIO FACILITIES, PHOTOGRAPHIC EQUIPMENT, PHOTOGRAPHIC AND FILM PRODUCTION EQUIPMENT, AND PHOTOGRAPHIC AND FILM LIGHTING APPARATUS; CAMERA, MOTION PICTURE AND VIDEO RENTAL SERVICES (U.S. CLS. 100, 101 AND 107).

FIRST USE 5-7-1997; IN COMMERCE 5-7-1997.

JOHN WILKE, EXAMINING ATTORNEY

**CLASS 41—(Continued).**

SN 85-145,708. JACK STUDIOS INC., NEW YORK, NY.  
FILED 10-5-2010.

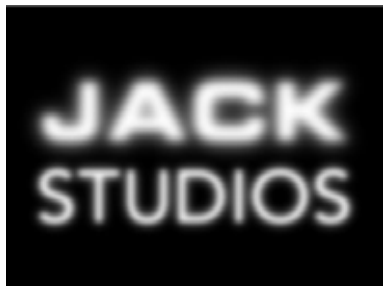

NO CLAIM IS MADE TO THE EXCLUSIVE RIGHT TO USE "STUDIOS", APART FROM THE MARK AS SHOWN.

THE MARK CONSISTS OF THE WORD "JACK" IN A BLURRED AND FUZZY FONT ON TOP OF THE WORD "STUDIOS" IN A LESS BLURRED AND FUZZY FONT WITH BOTH WORDS IN CAPITAL LETTERS ON A DARK BACKGROUND.

FOR DIGITAL IMAGING SERVICES; PROVIDING VISUAL, AUDIO AND VIDEO STUDIOS; RENTAL OF PHOTOGRAPHIC AND FILM STUDIO FACILITIES, PHOTOGRAPHIC EQUIPMENT, PHOTOGRAPHIC AND FILM PRODUCTION EQUIPMENT, AND PHOTOGRAPHIC AND FILM LIGHTING APPARATUS; CAMERA, MOTION PICTURE AND VIDEO RENTAL SERVICES (U.S. CLS. 100, 101 AND 107).

FIRST USE 5-7-1997; IN COMMERCE 5-7-1997.  
JOHN WILKE, EXAMINING ATTORNEY

**CLASS 41—(Continued).**

SN 85-145,893. NORRIDGE UNITED CHURCH OF CHRIST,  
NORRIDGE, IL. FILED 10-6-2010.



NO CLAIM IS MADE TO THE EXCLUSIVE RIGHT TO USE "HUNGARIAN GULYAS FESTIVAL", APART FROM THE MARK AS SHOWN.

THE MARK CONSISTS OF A POT HANGING FROM A CHAIN AND OVER A FLAME OF FIRE WITH A STRING OF FLOWERS HALFWAY AROUND THE BOTTOM OF THE POT. THE STYLIZED WORDING "HUNGARIAN GULYAS FESTIVAL" APPEARS VERTICALLY ALIGNED WITH THE STRING OF FLOWERS.

FOR ENTERTAINMENT SERVICES IN THE NATURE OF ORGANIZING ETHNIC COMMUNITY FESTIVALS FEATURING FOOD, REFRESHMENTS, AND ENTERTAINMENT (U.S. CLS. 100, 101 AND 107).

FIRST USE 5-31-2007; IN COMMERCE 5-31-2007.  
WENDY JUN, EXAMINING ATTORNEY

SN 85-145,803. HORIZON SOUND STUDIOS, LLC., FOREST,  
VA. FILED 10-5-2010.



NO CLAIM IS MADE TO THE EXCLUSIVE RIGHT TO USE "SOUND STUDIOS, LLC.", APART FROM THE MARK AS SHOWN.

FOR SOUND AND MUSIC RECORDING PRODUCTION SERVICES; INSTRUCTION IN THE FIELD OF MUSIC; ADVISORY SERVICES IN THE FIELD OF SOUND AND MUSIC RECORDING; SOUND RECORDING STUDIOS (U.S. CLS. 100, 101 AND 107).

DAVID TOOLEY, EXAMINING ATTORNEY

SN 85-146,085. BLUE DOT STUDIO INC, BROOKLYN, NY.  
FILED 10-6-2010.



NO CLAIM IS MADE TO THE EXCLUSIVE RIGHT TO USE ".COM", APART FROM THE MARK AS SHOWN.

THE MARK CONSISTS OF A MOUTH WITH THE STYLIZED TEXT "RANT VAN .COM GO IN & GO OFF".

FOR VIDEO PRODUCTION SERVICES (U.S. CLS. 100, 101 AND 107).

GILBERT SWIFT, EXAMINING ATTORNEY

**CLASS 41—(Continued).**

SN 85-146,643. COAST 2 COAST CUISINE, SANTA MONICA, CA. FILED 10-6-2010.

**COAST 2 COAST**  
c u i s i n e

NO CLAIM IS MADE TO THE EXCLUSIVE RIGHT TO USE "CUISINE", APART FROM THE MARK AS SHOWN.

THE MARK CONSISTS OF THE STYLIZED TEXT "COAST 2 COAST CUISINE" WITH A HORIZONTAL LINE/BAR ABOVE AND BELOW THE LETTERS "OAST" OF BOTH WORDS "COAST".

FOR ENTERTAINMENT IN THE NATURE OF ONGOING TELEVISION PROGRAMS IN THE FIELD OF COOKING (U.S. CLS. 100, 101 AND 107).

FIRST USE 10-4-2008; IN COMMERCE 10-4-2008.  
NAKIA HENRY, EXAMINING ATTORNEY

**CLASS 41—(Continued).**

SN 85-148,124. KLEIN, RACHEL, DBA NOT FAMOUS YET, SOMERVILLE, MA. FILED 10-8-2010.

## Not Famous Yet

THE MARK CONSISTS OF STANDARD CHARACTERS WITHOUT CLAIM TO ANY PARTICULAR FONT, STYLE, SIZE, OR COLOR.

FOR ENTERTAINMENT SERVICES, NAMELY, ARRANGING AND CONDUCTING NIGHTCLUB EVENTS, ENTERTAINMENT SERVICES, NAMELY, ARRANGING FOR TICKET RESERVATIONS FOR SHOWS AND OTHER ENTERTAINMENT EVENTS; ENTERTAINMENT SERVICES, NAMELY, BOOKING OF ENTERTAINMENT HALLS; ENTERTAINMENT SERVICES, NAMELY, CONSULTATION IN THE FIELD OF SPECIAL EVENT PLANNING FOR SOCIAL ENTERTAINMENT PURPOSES; ENTERTAINMENT SERVICES, NAMELY, PROVIDING A WEBSITE FEATURING INFORMATION IN THE FIELD OF MUSIC AND ENTERTAINMENT; ENTERTAINMENT SERVICES NAMELY, PROVIDING A WEB SITE FEATURING MUSICAL PERFORMANCES, MUSICAL VIDEOS, RELATED FILM CLIPS, PHOTOGRAPHS, AND OTHER MULTIMEDIA MATERIALS IN THE FIELD OF MUSICAL PERFORMANCES; ENTERTAINMENT SERVICES, NAMELY, PROVIDING PRERECORDED MUSIC, INFORMATION IN THE FIELD OF MUSIC, COMMENTARY AND ARTICLES ABOUT MUSIC, ALL ONLINE VIA A GLOBAL COMPUTER NETWORK; ENTERTAINMENT SERVICES IN THE NATURE OF TRAVELING TOURS FEATURING MUSIC; ENTERTAINMENT SERVICES, NAMELY, PROVIDING PRERECORDED MUSIC VIA COMPUTER; ENTERTAINMENT SERVICES, NAMELY, AUDIO RECORDING AND PRODUCTION, PRODUCTION OF MUSICAL VIDEO RECORDINGS, AND THE DISTRIBUTION OF SOUND AND MUSICAL VIDEO RECORDINGS VIA A GLOBAL INFORMATION NETWORK; ENTERTAINMENT SERVICES, NAMELY, PROVIDING PRERECORDED MUSIC, INFORMATION IN THE FIELD OF MUSIC, COMMENTARY AND ARTICLES ABOUT MUSIC, ALL ONLINE VIA A GLOBAL COMPUTER NETWORK, ENTERTAINMENT IN THE NATURE OF TRAVELING TOURS FEATURING MUSIC (U.S. CLS. 100, 101 AND 107).

JANICE L. MCMORROW, EXAMINING ATTORNEY

SN 85-147,174. CYLIENT, JOHNSTON, IA. FILED 10-7-2010.

## Coaching Moments

THE MARK CONSISTS OF STANDARD CHARACTERS WITHOUT CLAIM TO ANY PARTICULAR FONT, STYLE, SIZE, OR COLOR.

OWNER OF U.S. REG. NO. 3,433,190.

NO CLAIM IS MADE TO THE EXCLUSIVE RIGHT TO USE "COACHING", APART FROM THE MARK AS SHOWN.

FOR EDUCATION SERVICES, NAMELY, CONDUCTING INFORMAL ONLINE LEARNING PROGRAM VIA EMAIL IN THE FIELD OF INTEGRATING COACHING APPROACHES INTO ONE'S LEADERSHIP STYLE (U.S. CLS. 100, 101 AND 107).

FIRST USE 3-1-2009; IN COMMERCE 3-1-2009.  
AMEEN IMAM, EXAMINING ATTORNEY

**CLASS 41—(Continued).**

SN 85-148,504. AMI GROUP, INC., DBA INTENTIONAL RELATIONSHIPS, BOULDER, CO. FILED 10-8-2010.



NO CLAIM IS MADE TO THE EXCLUSIVE RIGHT TO USE "RELATIONSHIPS", "ROMANCE", "PERSONAL" AND "BUSINESS", APART FROM THE MARK AS SHOWN.

THE COLOR(S) GREEN, WHITE AND BLACK IS/ARE CLAIMED AS A FEATURE OF THE MARK.

THE MARK CONSISTS OF THE LETTERS ARE IN BASKERVILLE FONT APPEARING TO THE LEFT OF 3 GREEN LEAVES. THE LEAVES HAVE BLACK STEMS WITH WHITE TIPS WHERE THEY CONNECT TO THE LEAVES. NEXT TO THE TOP LEAF IS THE WORD, "ROMANCE", NEXT TO THE MIDDLE LEAF IS THE WORD, "PERSONAL" AND NEXT TO THE BOTTOM LEAF IS THE WORD, "BUSINESS". ALL WORDS ARE IN BLACK.

FOR BUSINESS EDUCATION AND TRAINING SERVICES, NAMELY, DEVELOPING, AND FACILITATING CUSTOMIZED IN-COMPANY LEADERSHIP AND EXECUTIVE DEVELOPMENT PROGRAMS, PROVIDING EXECUTIVE COACHING SERVICES, AND PROVIDING PUBLIC AND IN-COMPANY KEYNOTE PRESENTATIONS TO BUSINESS LEADERS; LIFE COACHING SERVICES IN THE FIELD OF ROMANTIC RELATIONSHIPS; PEER TO PEER COACHING SERVICES IN THE FIELD OF RELATIONSHIP COACHING; PERSONAL COACHING SERVICES IN THE FIELD OF COMMUNICATIONS; PROFESSIONAL COACHING SERVICES IN THE FIELD OF COMMUNICATIONS; PROVIDING GROUP COACHING AND LEARNING FORUMS IN THE FIELD OF LEADERSHIP DEVELOPMENT; PROVIDING GROUP COACHING IN THE FIELD OF RELATIONSHIPS (U.S. CLS. 100, 101 AND 107).

FIRST USE 3-1-2010; IN COMMERCE 3-1-2010.  
JEFFREY LOOK, EXAMINING ATTORNEY

SN 85-148,622. COACH ZAUNER, LLC, FOUNTAIN HILLS, AZ. FILED 10-8-2010.

### A Specialist's Path To PRO Football

THE MARK CONSISTS OF STANDARD CHARACTERS WITHOUT CLAIM TO ANY PARTICULAR FONT, STYLE, SIZE, OR COLOR.

NO CLAIM IS MADE TO THE EXCLUSIVE RIGHT TO USE "PRO FOOTBALL", APART FROM THE MARK AS SHOWN.

FOR EDUCATING AND TRAINING INDIVIDUALS TO PLAY PROFESSIONAL FOOTBALL (U.S. CLS. 100, 101 AND 107).

CAROLINE WOOD, EXAMINING ATTORNEY

**CLASS 41—(Continued).**

SN 85-148,704. TRIMMER, JEREMY, MURRAY, UT. FILED 10-8-2010.

## THE OMNITORIUM

THE MARK CONSISTS OF STANDARD CHARACTERS WITHOUT CLAIM TO ANY PARTICULAR FONT, STYLE, SIZE, OR COLOR.

FOR PLANETARIUMS AND INTERACTIVE MUSEUMS, NAMELY, SCIENCE CENTERS (U.S. CLS. 100, 101 AND 107).

LINDA POWELL, EXAMINING ATTORNEY

SN 85-148,858. TORTELLI, ABY ELENA, LOS ANGELES, CA. FILED 10-8-2010.



THE MARK CONSISTS OF A SKULL IN THE CENTER OF THE MARK. TWO GUNS ARE POSITIONED TO FORM AN X AND APPEAR BEHIND THE SKULL WITH SMOKE COMING OUT OF THE BARREL OF EACH GUN. THE WORD "SMOKIN" APPEARS ABOVE THE SKULL AND THE WORD "GUN S" APPEARS BELOW THE SKULL.

FOR ENTERTAINMENT IN THE NATURE OF VISUAL AND AUDIO PERFORMANCES BY MUSICAL ARTISTS; ENTERTAINMENT SERVICES IN THE NATURE OF LIVE MUSICAL PERFORMANCES; ENTERTAINMENT SERVICES IN THE NATURE OF RECORDING, PRODUCTION AND POST-PRODUCTION SERVICES IN THE FIELD OF MUSIC; ENTERTAINMENT SERVICES, NAMELY, NON-DOWNLOADABLE RINGTONES, PRE-RECORDED MUSIC, AND GRAPHICS PRESENTED TO MOBILE COMMUNICATIONS DEVICES VIA A GLOBAL COMPUTER NETWORK AND WIRELESS NETWORKS; ENTERTAINMENT SERVICES, NAMELY, PROVIDING NON-DOWNLOADABLE PLAYBACK OF MUSIC VIA GLOBAL COMMUNICATIONS NETWORKS; ENTERTAINMENT SERVICES, NAMELY, PROVIDING ONLINE REVIEWS OF MUSIC AND/OR MUSICAL ARTISTS; ENTERTAINMENT, NAMELY, LIVE MUSIC CONCERTS; ENTERTAINMENT, NAMELY, LIVE PERFORMANCES BY A MUSICAL BAND; LIVE PERFORMANCES BY A MUSICAL GROUP; MOTION PICTURE FILM PRODUCTION; PRODUCTION OF DVDS FEATURING MUSIC AND/OR MUSICAL ARTISTS; PRODUCTION OF MUSICAL SOUND RECORDING; PRODUCTION OF SOUND RECORDINGS; PROVIDING A WEBSITE FEATURING INFORMATION IN THE FIELD OF MUSIC (U.S. CLS. 100, 101 AND 107).

BRIAN CALLAGHAN, EXAMINING ATTORNEY

**CLASS 41—(Continued).**

SN 85-148,935. RETIREMENT LIVING TV, LLC, BALTIMORE, MD. FILED 10-8-2010.

## Taking Care with Joan Lunden

THE MARK CONSISTS OF STANDARD CHARACTERS WITHOUT CLAIM TO ANY PARTICULAR FONT, STYLE, SIZE, OR COLOR.

THE NAME(S), PORTRAIT(S), AND/OR SIGNATURE(S) SHOWN IN THE MARK IDENTIFIES "JOAN LUNDEN", WHOSE CONSENT(S) TO REGISTER IS MADE OF RECORD.

FOR ENTERTAINMENT IN THE NATURE OF ONGOING TELEVISION PROGRAMS IN THE FIELD OF CAREGIVING FOR A LOVED ONE BROADCAST OVER TELEVISION, SATELLITE, AUDIO AND VIDEO MEDIA (U.S. CLS. 100, 101 AND 107).

WON TEAK OH, EXAMINING ATTORNEY

---

SN 85-149,266. STEPHEN A GRILLO, DBA DWAPARA YOGA, PAHOA, HI. FILED 10-11-2010.

## Dwapara Yoga

THE MARK CONSISTS OF STANDARD CHARACTERS WITHOUT CLAIM TO ANY PARTICULAR FONT, STYLE, SIZE, OR COLOR.

NO CLAIM IS MADE TO THE EXCLUSIVE RIGHT TO USE "YOGA", APART FROM THE MARK AS SHOWN.

THE ENGLISH TRANSLATION OF THE WORD "DWAPARA" IN THE MARK IS "THE STEADY HEART STATE OF MAN".

SEC. 2(F).

FOR PROVIDING YOGA AND MEDITATION INSTRUCTION, CLASSES AND TRAINING (U.S. CLS. 100, 101 AND 107).

FIRST USE 5-16-2010; IN COMMERCE 5-16-2010.

GIANCARLO CASTRO, EXAMINING ATTORNEY

---

SN 85-150,560. FEDERKEIL, EDWARD, FT. LAUDERDALE, FL. FILED 10-12-2010.

## Fireman Ed

THE MARK CONSISTS OF STANDARD CHARACTERS WITHOUT CLAIM TO ANY PARTICULAR FONT, STYLE, SIZE, OR COLOR.

THE NAME "FIREMAN ED" IDENTIFIES A LIVING INDIVIDUAL WHOSE CONSENT IS OF RECORD.

FOR ON-LINE JOURNALS, NAMELY, BLOGS FEATURING ADVICE TO INDIVIDUALS AND TIPS ON WHAT TO PURCHASE FOR THEIR MATE OR SIGNIFICANT OTHER (U.S. CLS. 100, 101 AND 107).

GILBERT SWIFT, EXAMINING ATTORNEY

**CLASS 41—(Continued).**

SN 85-150,753. ORAL ROBERTS EVANGELISTIC ASSOCIATION, TULSA, OK. FILED 10-12-2010.

## SCHOOL OF THE SPIRIT

THE MARK CONSISTS OF STANDARD CHARACTERS WITHOUT CLAIM TO ANY PARTICULAR FONT, STYLE, SIZE, OR COLOR.

NO CLAIM IS MADE TO THE EXCLUSIVE RIGHT TO USE "SCHOOL", APART FROM THE MARK AS SHOWN.

FOR EDUCATION SERVICES, NAMELY, PROVIDING LIVE AND ON-LINE CLASSES IN THE FIELD OF CHRISTIANITY (U.S. CLS. 100, 101 AND 107).

FIRST USE 7-1-2010; IN COMMERCE 7-1-2010.

BARBARA A. GOLD, EXAMINING ATTORNEY

---

SN 85-152,373. BEST ADVANTAGE DEVELOPMENT GROUP, INC., DBA COLLEGIATE STRATEGY, MILAN, IL. FILED 10-14-2010.



NO CLAIM IS MADE TO THE EXCLUSIVE RIGHT TO USE "COLLEGIATE", APART FROM THE MARK AS SHOWN.

THE COLOR(S) ORANGE, RED, BLACK AND WHITE IS/ARE CLAIMED AS A FEATURE OF THE MARK.

THE MARK CONSISTS OF A WHITE HAND OF STUDENT WEARING BLACK GRADUATION GOWN HOLDING A WHITE DIPLOMA TIED WITH A BLACK RIBBON SET AGAINST AN ORANGE RECTANGULAR BACKGROUND ADJACENT ON THE RIGHT ARE THE WORDS "COLLEGIATE STRATEGY" WITH THE WORD "COLLEGIATE" STARTING IN ORANGE AND TRANSITIONING TO RED WITH HORIZONTAL LINE BELOW "COLLEGIATE" THAT TRANSITIONS FROM ORANGE TO RED FROM LEFT TO RIGHT. BELOW THE LINE IS THE WORD "STRATEGY" IN RED.

FOR ON-LINE ELECTRONIC NEWSLETTERS DELIVERED BY E-MAIL IN THE FIELD OF COLLEGE STUDENT LIFE AND GUIDANCE; PROVIDING ON-LINE E-ZINES IN THE FIELD OF COLLEGE STUDENT LIFE AND GUIDANCE; PROVIDING ON-LINE NEWSLETTERS IN THE FIELD OF COLLEGE STUDENT LIFE AND GUIDANCE; PUBLICATION OF AN E-ZINE (U.S. CLS. 100, 101 AND 107).

FIRST USE 10-7-2010; IN COMMERCE 10-7-2010.

JEFFREY LOOK, EXAMINING ATTORNEY

**CLASS 41—(Continued).**

SN 85-152,728. NATIONAL BOARD OF OSTEOPATHIC MEDICAL EXAMINERS, INC., AKA NBOME, CHICAGO, IL. FILED 10-14-2010.



OWNER OF U.S. REG. NOS. 1,845,985 AND 1,954,122.  
 NO CLAIM IS MADE TO THE EXCLUSIVE RIGHT TO USE "BOARD OF OSTEOPATHIC MEDICAL EXAMINERS" AND "SINCE 1934", APART FROM THE MARK AS SHOWN.  
 THE MARK CONSISTS OF A CIRCULAR SEAL DESIGN DIVIDED INTO THREE PANELS DEPICTING THE ROD OF ASCLEPIUS, A PAIR OF HANDS (THE RIGHT CROSSING OVER THE OTHER) AND AN OPEN BOOK WITH THE LETTERS "D" AND "O" ON SEPARATE PAGES; WITHIN A BAND AROUND THE PERIMETER OF THE SEAL ARE "NATIONAL BOARD OF OSTEOPATHIC MEDICAL EXAMINERS" AND "SINCE 1934".

SEC. 2(F) AS TO "NATIONAL BOARD OF OSTEOPATHIC MEDICAL EXAMINERS".

FOR PREPARING, ADMINISTERING AND SCORING OF STANDARDIZED TESTS FOR OSTEOPATHIC PHYSICIANS AND SURGEONS, CONSULTING SERVICES IN THE EVALUATION OF OSTEOPATHIC MEDICAL CURRICULA AND STUDENT QUALIFICATIONS FOR OSTEOPATHIC COLLEGES AND STUDENTS, AND CONSULTING SERVICES TO STATE LICENSING BOARDS ON THE QUALIFICATIONS AND CANDIDATES FOR LICENSURE TO PRACTICE OSTEOPATHIC MEDICINE (U.S. CLS. 100, 101 AND 107).

FIRST USE 3-0-2010, THE MARK WAS FIRST USED ANYWHERE IN A DIFFERENT FORM OTHER THAN THAT SOUGHT TO BE REGISTERED AT LEAST AS EARLY AS 07/31/1986; IN COMMERCE 3-0-2010, THE MARK WAS FIRST USED IN COMMERCE IN A DIFFERENT FORM OTHER THAN THAT SOUGHT TO BE REGISTERED AT LEAST AS EARLY AS 07/31/1986.

CURTIS FRENCH, EXAMINING ATTORNEY

**CLASS 41—(Continued).**

SN 85-152,824. NATIONAL BOARD OF OSTEOPATHIC MEDICAL EXAMINERS, INC., AKA NBOME, CHICAGO, IL. FILED 10-14-2010.



OWNER OF U.S. REG. NOS. 1,834,102, 1,845,985 AND 1,954,122.

NO CLAIM IS MADE TO THE EXCLUSIVE RIGHT TO USE "BOARD OF OSTEOPATHIC MEDICAL EXAMINERS" AND "SINCE 1934", APART FROM THE MARK AS SHOWN.

THE MARK CONSISTS OF THE TERM "NBOME" IN LARGE BLOCK LETTERS ABOVE THE APPLICANT'S NAME, "NATIONAL BOARD OF OSTEOPATHIC MEDICAL EXAMINERS", TO THE RIGHT OF A CIRCULAR SEAL DESIGN DIVIDED INTO THREE PANELS DEPICTING THE ROD OF ASCLEPIUS, A PAIR OF HANDS AND AN OPEN BOOK WITH THE LETTERS "D" AND "O" ON SEPARATE PAGES, WITH THE APPLICANT'S NAME AND "SINCE 1934" IN A BAND AROUND THE SEAL PERIMETER; ALL OF WHICH IS BETWEEN TWO THIN HORIZONTAL LINES.

SEC. 2(F) AS TO "NATIONAL BOARD OF OSTEOPATHIC MEDICAL EXAMINERS".

FOR PREPARING, ADMINISTERING AND SCORING OF STANDARDIZED TESTS FOR OSTEOPATHIC PHYSICIANS AND SURGEONS, CONSULTING SERVICES IN THE EVALUATION OF OSTEOPATHIC MEDICAL CURRICULA AND STUDENT QUALIFICATIONS FOR OSTEOPATHIC COLLEGES AND STUDENTS, AND CONSULTING SERVICES TO STATE LICENSING BOARDS ON THE QUALIFICATIONS AND CANDIDATES FOR LICENSURE TO PRACTICE OSTEOPATHIC MEDICINE (U.S. CLS. 100, 101 AND 107).

FIRST USE 4-0-2010, THE MARK WAS FIRST USED ANYWHERE IN A DIFFERENT FORM OTHER THAN THAT SOUGHT TO BE REGISTERED AT LEAST AS EARLY AS 07/31/1986; IN COMMERCE 4-0-2010, THE MARK WAS FIRST USED IN COMMERCE IN A DIFFERENT FORM OTHER THAN THAT SOUGHT TO BE REGISTERED AT LEAST AS EARLY AS 07/31/1986.

CURTIS FRENCH, EXAMINING ATTORNEY

**CLASS 41—(Continued).**

SN 85-152,885. NATIONAL BOARD OF OSTEOPATHIC MEDICAL EXAMINERS, INC., AKA NBOME, CHICAGO, IL. FILED 10-14-2010.



OWNER OF U.S. REG. NOS. 1,834,102 AND 1,954,122.  
NO CLAIM IS MADE TO THE EXCLUSIVE RIGHT TO USE "BOARD OF OSTEOPATHIC MEDICAL EXAMINERS", APART FROM THE MARK AS SHOWN.

THE MARK CONSISTS OF THE TERM NBOME IN LARGE BLOCK LETTERS ABOVE THE APPLICANT'S NAME, NATIONAL BOARD OF OSTEOPATHIC MEDICAL EXAMINERS, ALL BETWEEN TWO THIN HORIZONTAL LINES.

SEC. 2(F) AS TO "NATIONAL BOARD OF OSTEOPATHIC MEDICAL EXAMINERS".

FOR PREPARING, ADMINISTERING AND SCORING OF STANDARDIZED TESTS FOR OSTEOPATHIC PHYSICIANS AND SURGEONS, CONSULTING SERVICES IN THE EVALUATION OF OSTEOPATHIC MEDICAL CURRICULA AND STUDENT QUALIFICATIONS FOR OSTEOPATHIC COLLEGES AND STUDENTS, AND CONSULTING SERVICES TO STATE LICENSING BOARDS ON THE QUALIFICATIONS AND CANDIDATES FOR LICENSURE TO PRACTICE OSTEOPATHIC MEDICINE (U.S. CLS. 100, 101 AND 107).

FIRST USE 4-0-2010, THE MARK WAS FIRST USED ANYWHERE IN A DIFFERENT FORM OTHER THAN THAT SOUGHT TO BE REGISTERED AT LEAST AS EARLY AS 07/31/1986; IN COMMERCE 4-0-2010, THE MARK WAS FIRST USED IN COMMERCE IN A DIFFERENT FORM OTHER THAN THAT SOUGHT TO BE REGISTERED AT LEAST AS EARLY AS 07/31/1986.

CURTIS FRENCH, EXAMINING ATTORNEY

**CLASS 41—(Continued).**

SN 85-152,951. NATIONAL BOARD OF OSTEOPATHIC MEDICAL EXAMINERS, INC., AKA NBOME, CHICAGO, IL. FILED 10-14-2010.



OWNER OF U.S. REG. NOS. 1,834,102, 1,845,985 AND 1,954,122.

NO CLAIM IS MADE TO THE EXCLUSIVE RIGHT TO USE "BOARD OF OSTEOPATHIC MEDICAL EXAMINERS" AND "SINCE 1934", APART FROM THE MARK AS SHOWN.

THE MARK CONSISTS OF THE TERM "NBOME" IN LARGE BLOCK LETTERS ABOVE THE APPLICANT'S NAME, "NATIONAL BOARD OF OSTEOPATHIC MEDICAL EXAMINERS", TO THE RIGHT OF A CIRCULAR SEAL DESIGN DIVIDED INTO THREE PANELS DEPICTING THE ROD OF ASCLEPIUS, A PAIR OF HANDS AND AN OPEN BOOK WITH THE LETTERS "D" AND "O" ON SEPARATE PAGES, WITH THE APPLICANT'S NAME AND "SINCE 1934" IN A BAND AROUND THE SEAL PERIMETER; ALL OF WHICH IS BETWEEN TWO THIN HORIZONTAL LINES.

SEC. 2(F) AS TO "NATIONAL BOARD OF OSTEOPATHIC MEDICAL EXAMINERS".

FOR PREPARING, ADMINISTERING AND SCORING OF STANDARDIZED TESTS FOR OSTEOPATHIC PHYSICIANS AND SURGEONS, CONSULTING SERVICES IN THE EVALUATION OF OSTEOPATHIC MEDICAL CURRICULA AND STUDENT QUALIFICATIONS FOR OSTEOPATHIC COLLEGES AND STUDENTS, AND CONSULTING SERVICES TO STATE LICENSING BOARDS ON THE QUALIFICATIONS AND CANDIDATES FOR LICENSURE TO PRACTICE OSTEOPATHIC MEDICINE (U.S. CLS. 100, 101 AND 107).

FIRST USE 4-0-2010, THE MARK WAS FIRST USED ANYWHERE IN A DIFFERENT FORM OTHER THAN THAT SOUGHT TO BE REGISTERED AT LEAST AS EARLY AS 07/31/1986; IN COMMERCE 4-0-2010, THE MARK WAS FIRST USED IN COMMERCE IN A DIFFERENT FORM OTHER THAN THAT SOUGHT TO BE REGISTERED AT LEAST AS EARLY AS 07/31/1986.

CURTIS FRENCH, EXAMINING ATTORNEY

SN 85-153,003. NATIONAL BOARD OF OSTEOPATHIC MEDICAL EXAMINERS, INC., AKA NBOME, CHICAGO, IL. FILED 10-14-2010.



OWNER OF U.S. REG. NOS. 1,834,102, 1,845,985 AND 1,954,122.

NO CLAIM IS MADE TO THE EXCLUSIVE RIGHT TO USE "BOARD OF OSTEOPATHIC MEDICAL EXAMINERS" AND "SINCE 1934", APART FROM THE MARK AS SHOWN.

THE COLOR(S) WHITE AND BLUE IS/ARE CLAIMED AS A FEATURE OF THE MARK.

THE MARK CONSISTS OF THE TERM "NBOME" IN LARGE BLOCK LETTERS ABOVE THE APPLICANT'S NAME, "NATIONAL BOARD OF OSTEOPATHIC MEDICAL EXAMINERS", TO THE RIGHT OF A CIRCULAR SEAL

**CLASS 41—(Continued).**

DESIGN DIVIDED INTO THREE PANELS DEPICTING THE ROD OF ASCLEPIUS, A PAIR OF HANDS AND AN OPEN BOOK WITH THE LETTERS "D" AND "O" ON SEPARATE PAGES, WITH THE APPLICANT'S NAME AND "SINCE 1934" IN A BAND AROUND THE SEAL PERIMETER; ALL OF WHICH IS BETWEEN TWO THIN HORIZONTAL LINES. EXCEPT FOR THOSE LINES AND THE "O" IN "NBOME", WHICH ARE LIGHT BLUE IN COLOR, ALL LETTERING AND DEVICES ARE IN WHITE ON A DARKER BLUE BACKGROUND.

SEC. 2(F) AS TO "NATIONAL BOARD OF OSTEOPATHIC MEDICAL EXAMINERS".

FOR PREPARING, ADMINISTERING AND SCORING OF STANDARDIZED TESTS FOR OSTEOPATHIC PHYSICIANS AND SURGEONS, CONSULTING SERVICES IN THE EVALUATION OF OSTEOPATHIC MEDICAL CURRICULA AND STUDENT QUALIFICATIONS FOR OSTEOPATHIC COLLEGES AND STUDENTS, AND CONSULTING SERVICES TO STATE LICENSING BOARDS ON THE QUALIFICATIONS AND CANDIDATES FOR LICENSURE TO PRACTICE OSTEOPATHIC MEDICINE (U.S. CLS. 100, 101 AND 107).

FIRST USE 4-0-2010, THE MARK WAS FIRST USED ANYWHERE IN A DIFFERENT FORM OTHER THAN THAT SOUGHT TO BE REGISTERED AT LEAST AS EARLY AS 07/31/1986; IN COMMERCE 4-0-2010, THE MARK WAS FIRST USED IN COMMERCE IN A DIFFERENT FORM OTHER THAN THAT SOUGHT TO BE REGISTERED AT LEAST AS EARLY AS 07/31/1986.

CURTIS FRENCH, EXAMINING ATTORNEY

**CLASS 41—(Continued).**

SN 85-153,216. XPRO TRAINING CONSULTANTS, POTOMAC, MD. FILED 10-14-2010.



THE MARK CONSISTS OF THE STYLIZED WORDING "XPRO" WHERE "X" AND "P" ARE FORMED BY A SWOOPING ARC AND "RO" SLANTS UPWARD AND TOWARDS THE RIGHT.

FOR ATHLETIC TRAINING SERVICES (U.S. CLS. 100, 101 AND 107).

FIRST USE 1-4-2010; IN COMMERCE 1-4-2010.

KATHERINE E. HALMEN, EXAMINING ATTORNEY

SN 85-153,261. BAKER, BETTY J., DOWNEY, CA. AND BAKER, JAMIE C., DOWNEY, CA. FILED 10-14-2010.

### Focusing On Successful Documentary Productions (FOSDP)

THE MARK CONSISTS OF STANDARD CHARACTERS WITHOUT CLAIM TO ANY PARTICULAR FONT, STYLE, SIZE, OR COLOR.

NO CLAIM IS MADE TO THE EXCLUSIVE RIGHT TO USE "DOCUMENTARY PRODUCTIONS", APART FROM THE MARK AS SHOWN.

FOR MEDIA PRODUCTION SERVICES, NAMELY, FILM AND VIDEO PRODUCTION (U.S. CLS. 100, 101 AND 107).

FIRST USE 10-1-2010; IN COMMERCE 10-1-2010.

DORITT L. CARROLL, EXAMINING ATTORNEY



SN 85-153,071. AMERICAN ACADEMY OF FAMILY PHYSICIANS, LEAWOOD, KS. FILED 10-14-2010.

NO CLAIM IS MADE TO THE EXCLUSIVE RIGHT TO USE "OB", APART FROM THE MARK AS SHOWN.

THE MARK CONSISTS OF THE WORDING "CARETEAM" NEXT TO A BOX CONTAINING THE LETTERS "OB" IN THE LOWER PORTION OF THE BOX.

FOR EDUCATIONAL SERVICES, NAMELY, MEDICAL PATIENT SAFETY TRAINING IN THE FIELD OF OBSTETRICS (U.S. CLS. 100, 101 AND 107).

FIRST USE 10-0-2009; IN COMMERCE 4-19-2010.

FONG HSU, EXAMINING ATTORNEY

SN 85-153,519. NIKITA DEBOURGEOIS, HOUSTON, TX. FILED 10-15-2010.

### Children With Wings

THE MARK CONSISTS OF STANDARD CHARACTERS WITHOUT CLAIM TO ANY PARTICULAR FONT, STYLE, SIZE, OR COLOR.

FOR PROVIDING EDUCATIONAL MENTORING SERVICES AND PROGRAMS IN THE FIELD OF GENERAL EDUCATION FOR INNER CITY ELEMENTARY AND MIDDLE SCHOOL STUDENTS (U.S. CLS. 100, 101 AND 107).

PAUL E. FAHRENKOPF, EXAMINING ATTORNEY



**CLASS 41—(Continued).**

SN 85-153,555. GREENE, MARIA ELENA GIRALDO, AR-  
LINGTON, VA. FILED 10-15-2010.

**HOLA BABY**

THE MARK CONSISTS OF STANDARD CHARACTERS  
WITHOUT CLAIM TO ANY PARTICULAR FONT, STYLE,  
SIZE, OR COLOR.

OWNER OF U.S. REG. NO. 3,385,430.

NO CLAIM IS MADE TO THE EXCLUSIVE RIGHT TO  
USE "BABY", APART FROM THE MARK AS SHOWN.

FOR EDUCATION SERVICE PROVIDING SPANISH  
IMMERSION PLAYGROUPS FOR BABIES AND TOD-  
DLERS (U.S. CLS. 100, 101 AND 107).

FIRST USE 5-0-2005; IN COMMERCE 5-0-2005.

LINDA ORNDORFF, EXAMINING ATTORNEY

**CLASS 41—(Continued).**

SN 85-154,284. HAN, PETER, CONROE, TX. AND FERNAN-  
DEZ-HAN, FABIAN R., CONROE, TX. FILED 10-15-2010.

**Oink-A-Saurus**

THE MARK CONSISTS OF STANDARD CHARACTERS  
WITHOUT CLAIM TO ANY PARTICULAR FONT, STYLE,  
SIZE, OR COLOR.

FOR PROVIDING A WEBSITE FEATURING BLOGS IN  
THE FIELD OF PERSONAL FINANCIAL PLANNING;  
EDUCATIONAL SERVICES, NAMELY, CONDUCTING  
CLASSES, WORKSHOPS, CONFERENCES AND SEMI-  
NARS IN THE FIELD OF PERSONAL FINANCIAL  
PLANNING ALL VIA A GLOBAL COMPUTER NET-  
WORK; ENTERTAINMENT SERVICES, NAMELY,  
STORYTELLING ABOUT PERSONAL FINANCIAL  
PLANNING ALL VIA A GLOBAL COMPUTER NET-  
WORK; EDUCATIONAL AND ENTERTAINMENT SER-  
VICES, NAMELY, PROVIDING MOTIVATIONAL  
SPEAKING SERVICES IN THE FIELD OF PERSONAL  
FINANCIAL PLANNING, SAVING, INVESTING, SPEND-  
ING, BORROWING, CHARITABLE GIVING AND DIS-  
TRIBUTION OF COURSE MATERIALS IN  
CONNECTION THEREWITH (U.S. CLS. 100, 101 AND  
107).

FIRST USE 9-14-2009; IN COMMERCE 12-9-2009.

BERYL GARDNER, EXAMINING ATTORNEY

SN 85-154,478. DNE ENTERPRISES LLC, DBA YOGA AT  
THE VILLAGE, GLENDALE, CA. FILED 10-17-2010.

**YOGA AT THE VILLAGE**

THE MARK CONSISTS OF STANDARD CHARACTERS  
WITHOUT CLAIM TO ANY PARTICULAR FONT, STYLE,  
SIZE, OR COLOR.

NO CLAIM IS MADE TO THE EXCLUSIVE RIGHT TO  
USE "YOGA", APART FROM THE MARK AS SHOWN.

FOR PROVIDING COURSES OF INSTRUCTION IN  
YOGA, PHYSICAL EXERCISE, STRETCHING, AND  
BREATHING TECHNIQUE (U.S. CLS. 100, 101 AND 107).

FIRST USE 11-1-2005; IN COMMERCE 11-1-2005.

CORY BOONE, EXAMINING ATTORNEY

SN 85-154,257. GIETZEN, ERIC J., SHOREWOOD, WI. FILED  
10-15-2010.

**Sweetwater  
Salvation**

THE MARK CONSISTS OF STANDARD CHARACTERS  
WITHOUT CLAIM TO ANY PARTICULAR FONT, STYLE,  
SIZE, OR COLOR.

FOR ENTERTAINMENT SERVICES, NAMELY, A  
MULTIMEDIA PROGRAM SERIES FEATURING COME-  
DY, ACTION AND ADVENTURE DISTRIBUTED VIA  
VARIOUS PLATFORMS ACROSS MULTIPLE FORMS OF  
TRANSMISSION MEDIA (U.S. CLS. 100, 101 AND 107).

MARTHA FROMM, EXAMINING ATTORNEY

SN 85-154,479. DNE ENTERPRISES LLC, DBA YOGA AT  
THE VILLAGE, GLENDALE, CA. FILED 10-17-2010.

**INTRODUCE YOUR MIND TO  
YOUR BODY ... THEY JUST  
MIGHT LIKE EACH OTHER**

THE MARK CONSISTS OF STANDARD CHARACTERS  
WITHOUT CLAIM TO ANY PARTICULAR FONT, STYLE,  
SIZE, OR COLOR.

FOR PROVIDING COURSES OF INSTRUCTION IN  
YOGA, PHYSICAL EXERCISE, STRETCHING, AND  
BREATHING TECHNIQUE (U.S. CLS. 100, 101 AND 107).

FIRST USE 11-1-2005; IN COMMERCE 11-1-2005.

CORY BOONE, EXAMINING ATTORNEY

**CLASS 41—(Continued).**

SN 85-154,700. MICHIGAN TECHNOLOGICAL UNIVERSITY, HOUGHTON, MI. FILED 10-18-2010.



THE COLOR(S) BLUE, GREEN, PINK, AND ORANGE IS/ ARE CLAIMED AS A FEATURE OF THE MARK.

THE MARK CONSISTS OF THE OUTLINE OF A HUMAN HEAD IN BLUE WITH OVALS IN BLUE, GREEN AND PINK AROUND THE HEAD HAVING BLUE, GREEN AND ORANGE CIRCLES THROUGH THE LINES OF THE OVALS AND THE WORDS "MIND TREKKERS" WRITTEN IN BLUE BELOW. WHITE AS IT APPEARS IN THE MARK IS BACKGROUND ONLY AND IS NOT A FEATURE OF THE MARK.

FOR EDUCATIONAL SERVICES, NAMELY, PROVIDING DISPLAYS, EXHIBITIONS AND INTERACTIVE EXHIBITS IN THE FIELDS OF SCIENCE AND TECHNOLOGY (U.S. CLS. 100, 101 AND 107).

FIRST USE 4-1-2010; IN COMMERCE 4-1-2010.

REBECCA POVARCHUK, EXAMINING ATTORNEY

**CLASS 41—(Continued).**

SN 85-154,785. GOODWIN, DEREK, GILROY, CA. FILED 10-18-2010.

eapprentice

THE MARK CONSISTS OF STANDARD CHARACTERS WITHOUT CLAIM TO ANY PARTICULAR FONT, STYLE, SIZE, OR COLOR.

FOR PROVIDING ON-LINE NON-DOWNLOADABLE TRAINING VIDEOS AND WEBINARS IN THE FIELD OF MECHANICAL ENGINEERING AND INDUSTRIAL DESIGN (U.S. CLS. 100, 101 AND 107).

FIRST USE 7-1-2006; IN COMMERCE 8-1-2008.

MICHAEL WEBSTER, EXAMINING ATTORNEY

SN 85-154,839. SPADOTO, MAURY A, HOBOKEN, NJ. FILED 10-18-2010.

maury the photographer

SN 85-154,762. CHILAMKURTI, KIRAN, GURNEE, IL. FILED 10-18-2010.

KLOUD MEDIA GROUP

THE MARK CONSISTS OF STANDARD CHARACTERS WITHOUT CLAIM TO ANY PARTICULAR FONT, STYLE, SIZE, OR COLOR.

NO CLAIM IS MADE TO THE EXCLUSIVE RIGHT TO USE "MEDIA GROUP", APART FROM THE MARK AS SHOWN.

FOR MUSIC PRODUCTION SERVICES (U.S. CLS. 100, 101 AND 107).

BRENDAN MCCAULEY, EXAMINING ATTORNEY

THE MARK CONSISTS OF STANDARD CHARACTERS WITHOUT CLAIM TO ANY PARTICULAR FONT, STYLE, SIZE, OR COLOR.

NO CLAIM IS MADE TO THE EXCLUSIVE RIGHT TO USE "PHOTOGRAPHER", APART FROM THE MARK AS SHOWN.

THE NAME "MAURY" IDENTIFIES A LIVING INDIVIDUAL WHOSE CONSENT IS OF RECORD.

FOR PHOTOGRAPHY; PHOTOGRAPHY SERVICES; PORTRAIT PHOTOGRAPHY (U.S. CLS. 100, 101 AND 107).

FIRST USE 12-20-2008; IN COMMERCE 12-20-2008.

ANDREA K. NADELMAN, EXAMINING ATTORNEY

**CLASS 41—(Continued).**

SN 85-154,856. LOYOLA UNIVERSITY OF CHICAGO, CHICAGO, IL. FILED 10-18-2010.



OWNER OF U.S. REG. NOS. 3,005,676, 3,007,281 AND OTHERS.

NO CLAIM IS MADE TO THE EXCLUSIVE RIGHT TO USE "UNIVERSITY," "CHICAGO," AND "1870", APART FROM THE MARK AS SHOWN.

THE MARK CONSISTS OF A SHIELD DESIGN WITH THE WORDS LOYOLA UNIVERSITY CHICAGO ABOVE THE SHIELD; THE WORDS AD MAJOREM DEI GLORIAM CURVED AROUND THE SHIELD; AND 1870 AND A DESIGN OF TWO WOLVES STANDING OVER A KETTLE INSIDE THE SHIELD.

THE ENGLISH TRANSLATION OF "AD MAJOREM DEI GLORIAM" IN THE MARK IS "FOR THE GREATER GLORY OF GOD".

FOR EDUCATIONAL SERVICES, NAMELY, PROVIDING COURSES OF INSTRUCTION AT THE UNIVERSITY LEVEL (U.S. CLS. 100, 101 AND 107).

FIRST USE 3-0-2006; IN COMMERCE 3-0-2006.  
DANIEL CAPSHAW, EXAMINING ATTORNEY

SN 85-154,865. HELOU, JIRIAR N., NEWARK, PA. FILED 10-18-2010.

**DJJNH**

THE MARK CONSISTS OF STANDARD CHARACTERS WITHOUT CLAIM TO ANY PARTICULAR FONT, STYLE, SIZE, OR COLOR.

FOR PROVIDING DISC JOCKEY SERVICES; MUSIC PRODUCTION SERVICES (U.S. CLS. 100, 101 AND 107).  
FIRST USE 4-15-2006; IN COMMERCE 4-15-2006.  
KEVIN DINALLO, EXAMINING ATTORNEY

**CLASS 41—(Continued).**

SN 85-154,964. KIWANIS CLUB OF LITTLE HAVANA, INC., MIAMI, FL. FILED 10-18-2010.

**CARNAVAL MIAMI**

THE MARK CONSISTS OF STANDARD CHARACTERS WITHOUT CLAIM TO ANY PARTICULAR FONT, STYLE, SIZE, OR COLOR.

OWNER OF U.S. REG. NO. 2,907,418.

THE ENGLISH TRANSLATION OF "CARNAVAL" IN THE MARK IS "CARNIVAL".

SEC. 2(F).

FOR ARRANGING, ORGANIZING, CONDUCTING, AND HOSTING SOCIAL ENTERTAINMENT EVENTS; ORGANISATION OF GOLF TOURNAMENTS; ORGANIZING COMMUNITY FESTIVALS FEATURING A VARIETY OF ACTIVITIES, NAMELY, ART EXHIBITIONS, HERITAGE MARKETS, ETHNIC DANCES, AND THE LIKE; ORGANIZING COMMUNITY FESTIVALS FEATURING PRIMARILY A VARIETY OF ACTIVITIES: STREET FESTIVALS, COOKING CONTESTS, DOMINO TOURNAMENTS, POSTER CONTESTS, GOLF TOURNAMENTS, RUNNING EVENTS AND RACES AND ALSO PROVIDING MUSICAL CONCERTS (U.S. CLS. 100, 101 AND 107).

FIRST USE 2-29-2004; IN COMMERCE 2-29-2004.

JAMES A. RAUEN, EXAMINING ATTORNEY

SN 85-155,015. YOUTH CRIME WATCH OF AMERICA, INC., MIAMI, FL. FILED 10-18-2010.

**ignitus**  
WORLDWIDE

NO CLAIM IS MADE TO THE EXCLUSIVE RIGHT TO USE "WORLDWIDE", APART FROM THE MARK AS SHOWN.

THE MARK CONSISTS OF THE WORDS "IGNITUS WORLDWIDE" IN A STYLIZED FONT.

FOR ACADEMIC ENRICHMENT PROGRAMS IN THE FIELD(S) OF YOUTH LEADERSHIP, CIVIC ENGAGEMENT, CRIME PREVENTION, AND THE DEVELOPMENT OF MORAL CHARACTER; EDUCATION SERVICES, NAMELY, PROVIDING MENTORING, TUTORING, CLASSES, SEMINARS AND WORKSHOPS IN THE FIELD OF YOUTH LEADERSHIP, CIVIC ENGAGEMENT, CRIME PREVENTION, AND THE DEVELOPMENT OF MORAL CHARACTER; EDUCATION SERVICES, NAMELY, TRAINING EDUCATORS TO TEACH THROUGH SERVICE LEARNING AND CIVIC ENGAGEMENT AND PROVIDING CURRICULA IN CONNECTION THEREWITH (U.S. CLS. 100, 101 AND 107).

FIRST USE 10-13-2010; IN COMMERCE 10-13-2010.

DANNEAN HETZEL, EXAMINING ATTORNEY

**CLASS 41—(Continued).**

SN 85-155,238. JIVAMUKTI, INC., SHADY, NY. FILED 10-18-2010.

# JIVAMUKTI

THE MARK CONSISTS OF STANDARD CHARACTERS WITHOUT CLAIM TO ANY PARTICULAR FONT, STYLE, SIZE, OR COLOR.

OWNER OF U.S. REG. NO. 2,101,342.

THE WORDING "JIVAMUKTI" HAS NO MEANING IN A FOREIGN LANGUAGE.

FOR YOGA INSTRUCTION, NAMELY, YOGA CLASSES, WORKSHOPS, RETREATS, TEACHER TRAINING CLASSES AND DISTRIBUTION OF INSTRUCTIONAL MATERIALS IN THE NATURE OF VIDEO AND AUDIO TAPES ASSOCIATED THEREWITH (U.S. CLS. 100, 101 AND 107).

FIRST USE 1-1-1986; IN COMMERCE 1-1-1986.

AMY KERTGATE, EXAMINING ATTORNEY

**CLASS 41—(Continued).**

SN 85-155,308. DON'T DROP IN, LLC, GREENVALE, NY. FILED 10-18-2010.

NO CLAIM IS MADE TO THE EXCLUSIVE RIGHT TO USE "SURF MOVIE TONIGHT", APART FROM THE MARK AS SHOWN.

THE MARK CONSISTS OF THE WORDS "SURF MOVIE 2NITE NYSFF" IN A STYLIZED SCRIPT AND IN VERTICALLY STACKED RELATION WITH A HORIZONTAL LINE EXTENDING BETWEEN "2NITE" AND "NYSFF".

FOR CONDUCTING ENTERTAINMENT EXHIBITIONS IN THE NATURE OF SURF FILMS; ENTERTAINMENT SERVICES, NAMELY, PLANNING AND CONDUCTING A SERIES OF FILM FESTIVALS; PROVIDING INFORMATION AND ARTICLES IN THE FIELD OF FILM, FILMMAKING, AND ENTERTAINMENT VIA A GLOBAL COMPUTER NETWORK (U.S. CLS. 100, 101 AND 107).

KAREN K. BUSH, EXAMINING ATTORNEY

SN 85-155,253. CERSOVSKI, LESLIE A, VALDOSTA, GA. FILED 10-18-2010.

# Lavish Boudoir

THE MARK CONSISTS OF STANDARD CHARACTERS WITHOUT CLAIM TO ANY PARTICULAR FONT, STYLE, SIZE, OR COLOR.

NO CLAIM IS MADE TO THE EXCLUSIVE RIGHT TO USE "BOUDOIR", APART FROM THE MARK AS SHOWN. FOR PORTRAIT PHOTOGRAPHY (U.S. CLS. 100, 101 AND 107).

FIRST USE 3-21-2010; IN COMMERCE 3-21-2010.

APRIL HESIK, EXAMINING ATTORNEY

SN 85-155,618. AMGM LTD., LONDON, UNITED KINGDOM, FILED 10-19-2010.



THE COLOR(S) YELLOW, ORANGE, BROWN, BLACK, BLUE, GRAY AND WHITE IS/ARE CLAIMED AS A FEATURE OF THE MARK.

THE MARK CONSISTS OF THE FOLLOWING: A CIRCLE WITH A BROWN OUTER LINE AND YELLOW INTERIOR, THE WORDS "AFRAID COMPUTERS.COM" APPEAR IN

**CLASS 41—(Continued).**

YELLOW AND ORANGE WITH A BROWN OUTLINE AND GO AROUND THE EXTERIOR OF THE CIRCLE; A CARTOON REPRESENTATION OF A MAN WITH BLACK HAIR, WHITE EYES WITH BLUE PUPILS AND A BROWN AND ORANGE SHIRT HOLDING A BROWN BAT APPEARS INSIDE THE CIRCLE; IN FRONT OF THE MAN IS AN ARTISTIC RENDERING OF A COMPUTER MONITOR IN GRAY WITH A BLUE SCREEN; ON THE COMPUTER MONITOR'S SCREEN IS THE WORD "OF" IN YELLOW AND ORANGE WITH A BROWN OUTLINE.

FOR COMPUTER EDUCATION TRAINING SERVICES (U.S. CLS. 100, 101 AND 107).

FIRST USE 11-1-2009; IN COMMERCE 11-1-2009.  
RONALD MCMORROW, EXAMINING ATTORNEY

---

SN 85-155,692. LENNOX INDUSTRIES INC., RICHARDSON, TX. FILED 10-19-2010.



NO CLAIM IS MADE TO THE EXCLUSIVE RIGHT TO USE "HVAC ONLINE AND ONSITE LEARNING SOLUTIONS", APART FROM THE MARK AS SHOWN.

THE MARK CONSISTS OF THE LETTERS "HVAC" TO THE RIGHT OF A HEXAGON SHAPE COMPRISED OF SIX TRIANGLES, ALL OVER THE WORDING "ONLINE AND ONSITE" THAT IS TO THE RIGHT OF A LINE THAT EXTENDS FROM THE LEFT SIDE TO BENEATH THE LETTER "A" IN "HVAC", ALL OVER THE WORDING "LEARNING SOLUTIONS".

FOR EDUCATIONAL SERVICES, NAMELY, CONDUCTING CLASSES, SEMINARS, WORKSHOPS, WEB-BASED AND ONSITE TRAINING FOR HVAC TECHNICIANS (U.S. CLS. 100, 101 AND 107).

FIRST USE 1-0-2010; IN COMMERCE 1-0-2010.  
DOMINIC J. FERRAIUOLO, EXAMINING ATTORNEY

---

SN 85-155,795. HOTTELL, ANDREW, CHICAGO, IL. FILED 10-19-2010.

**INSPIRING PERFORMANCE,  
INSTILLING CAPABILITIES**

THE MARK CONSISTS OF STANDARD CHARACTERS WITHOUT CLAIM TO ANY PARTICULAR FONT, STYLE, SIZE, OR COLOR.

FOR PROFESSIONAL COACHING SERVICES IN THE FIELD OF PROFESSIONAL DEVELOPMENT (U.S. CLS. 100, 101 AND 107).

EDWARD FENNESSY, EXAMINING ATTORNEY

**CLASS 41—(Continued).**

SN 85-155,890. MAKLAF HOLDINGS, INC., CARSON CITY, NV. FILED 10-19-2010.

**CHEETAH COACHING**

THE MARK CONSISTS OF STANDARD CHARACTERS WITHOUT CLAIM TO ANY PARTICULAR FONT, STYLE, SIZE, OR COLOR.

OWNER OF U.S. REG. NOS. 2,570,749, 3,240,772 AND OTHERS.

NO CLAIM IS MADE TO THE EXCLUSIVE RIGHT TO USE "COACHING ", APART FROM THE MARK AS SHOWN.

FOR TRAINING SERVICES IN THE FIELD OF PROJECT MANAGEMENT (U.S. CLS. 100, 101 AND 107).

KRISTIN CARLSON, EXAMINING ATTORNEY

---

SN 85-156,014. HANDLER MARKETING, INC., PITTSBURGH, PA. FILED 10-19-2010.

**ENTERTAINMENT CENTRAL**

THE MARK CONSISTS OF STANDARD CHARACTERS WITHOUT CLAIM TO ANY PARTICULAR FONT, STYLE, SIZE, OR COLOR.

NO CLAIM IS MADE TO THE EXCLUSIVE RIGHT TO USE "ENTERTAINMENT", APART FROM THE MARK AS SHOWN.

FOR ENTERTAINMENT SERVICES IN THE NATURE OF CREATION, DEVELOPMENT, AND PRODUCTION OF TELEVISION PROGRAMMING FOR DISTRIBUTION THROUGH BROADCAST MEDIA INCLUDING TELEVISION, SATELLITE, INTERNET, RADIO, AUDIO, AND VIDEO MEDIA; DISTRIBUTION OF TELEVISION PROGRAMS FOR OTHERS; PROVIDING A WEBSITE FEATURING ENTERTAINMENT INFORMATION (U.S. CLS. 100, 101 AND 107).

RON FAIRBANKS, EXAMINING ATTORNEY

---

SN 85-156,182. MENTALNRG, LLC, CARMICHAEL, CA. FILED 10-19-2010.

**MENTALNRG**

THE MARK CONSISTS OF STANDARD CHARACTERS WITHOUT CLAIM TO ANY PARTICULAR FONT, STYLE, SIZE, OR COLOR.

FOR COMPUTER SERVICES, NAMELY, WEB-BASED SELF-HELP WORKSHOPS (U.S. CLS. 100, 101 AND 107).

KATHERINE CONNOLLY, EXAMINING ATTORNEY

**CLASS 41—(Continued).**

SN 85-156,201. HERNANDEZ, MICHAEL C., MATTHEWS, NC. FILED 10-19-2010.



THE COLOR(S) WHITE, BLACK, LIGHT ORANGE, ORANGE, DARK ORANGE, YELLOW, AND RED IS/ARE CLAIMED AS A FEATURE OF THE MARK.

THE MARK CONSISTS OF A BIRD APPEARING IN ORANGE AND LIGHT ORANGE, WITH A RED AND YELLOW BEAK, WEARING BLACK-RIMMED GLASSES SHADED IN WHITE AND CONTAINING BLACK EYES WITH WHITE DOTS WITHIN THE EYES. THE BIRD HAS ORANGE LEGS AND MUSICAL NOTES APPEAR TO THE RIGHT WITH ONE IN ORANGE AND THE OTHER IN DARK ORANGE ALL APPEARING ABOVE THE STYLIZED WORDING "CAPTURE HAPPY" APPEARING IN BLACK.

FOR PHOTOGRAPHY SERVICES (U.S. CLS. 100, 101 AND 107).

FIRST USE 2-10-2010; IN COMMERCE 3-0-2010.

JACLYN KIDWELL WALKER, EXAMINING ATTORNEY

---

SN 85-156,229. AQUALINA INTERNATIONAL CORPORATION, PANAMA, PANAMA, FILED 10-19-2010.



NO CLAIM IS MADE TO THE EXCLUSIVE RIGHT TO USE "MUESTRA INTERNACIONAL DE CINE COLOMBIANO", APART FROM THE MARK AS SHOWN.

THE MARK CONSISTS OF AN IMAGE OF A COFFEE CUP WITH SMOKE RISING OUT OF THE CENTER WHICH TURNS INTO A MOVIE STRIP. THE WORDS "MUESTRA" IN A TILTED STYLIZED FONT IN UPPERCASE LETTERS TO THE RIGHT OF THE CUP. THE WORDS "INTERNACIONAL DE CINE COLOMBIANO" TO THE RIGHT OF THE COFFEE CUP DESIGN AND BELOW "MUESTRA".

THE ENGLISH TRANSLATION OF "MUESTRA INTERNACIONAL DE CINE COLOMBIANO" IS "SAMPLE OF INTERNATIONAL COLUMBIAN CINEMA".

FOR CONDUCTING ENTERTAINMENT EXHIBITIONS IN THE NATURE OF COLOMBIAN CINEMA; ENTERTAINMENT SERVICES, NAMELY, PLANNING AND CONDUCTING A SERIES OF FILM FESTIVALS (U.S. CLS. 100, 101 AND 107).

KATHY DE JONGE, EXAMINING ATTORNEY

**CLASS 41—(Continued).**

SN 85-156,242. UNIVERSAL FORCE, INC., NEW YORK, NY. FILED 10-19-2010.

**NAAM GLOBAL**

THE MARK CONSISTS OF STANDARD CHARACTERS WITHOUT CLAIM TO ANY PARTICULAR FONT, STYLE, SIZE, OR COLOR.

OWNER OF U.S. REG. NO. 3,433,107.

NO CLAIM IS MADE TO THE EXCLUSIVE RIGHT TO USE "GLOBAL", APART FROM THE MARK AS SHOWN.

FOR INSTRUCTION IN THE FIELD OF NON-RELIGIOUS JUDEO-CHRISTIAN KABBALISTIC METHODOLOGY, NAMELY, THEOSOPHIC STUDY OF THE LAWS OF NATURE, MAN AND GOD; INSTRUCTION IN THE FIELD OF YOGA, NAMELY, A PROGRAM COMBINING YOGA, PRAYER, MANTRAS, MUDRAS, BREATHING TECHNIQUES, SELF-HEALING AND SPECIFIC FORMS OF KABBALAH; INSTRUCTION IN A TRANSCENDENTAL SYSTEM OF BIO-METAPHYSICAL MEDICINE FOR HEALING AND SELF-HEALING DERIVED FROM SPIRITUAL TEACHINGS, NAMELY, NON-RELIGIOUS ASPECTS OF KABBALISTIC METHODOLOGY COMPRISING THE THEOSOPHIC STUDY OF THE LAWS OF NATURE, MAN AND GOD (U.S. CLS. 100, 101 AND 107).

MORGAN WYNNE, EXAMINING ATTORNEY

---

SN 85-156,254. HOUSTON LIVESTOCK SHOW & RODEO, INC., HOUSTON, TX. FILED 10-19-2010.

**SUPER SHOOTOUT**

THE MARK CONSISTS OF STANDARD CHARACTERS WITHOUT CLAIM TO ANY PARTICULAR FONT, STYLE, SIZE, OR COLOR.

NO CLAIM IS MADE TO THE EXCLUSIVE RIGHT TO USE "SUPER", APART FROM THE MARK AS SHOWN.

FOR ENTERTAINMENT IN THE NATURE OF RODEO CONTESTS (U.S. CLS. 100, 101 AND 107).

DAWN FELDMAN, EXAMINING ATTORNEY

**CLASS 41—(Continued).**

SN 85-156,263. ROSSI, BRYON VITTORIO, STERLING HEIGHTS, MI. AND MULLINIKS, MICHAEL PAUL, STERLING HEIGHTS, MI. AND ZOTT, DANIEL NEAL, STERLING HEIGHTS, MI. AND SAPUTO, STEPHEN MICHAEL, STERLING HEIGHTS, MI. AND ROSSI, DANIEL LUIGI, STERLING HEIGHTS, MI. FILED 10-19-2010.

**THE AMERICAN SECRETS**

THE MARK CONSISTS OF STANDARD CHARACTERS WITHOUT CLAIM TO ANY PARTICULAR FONT, STYLE, SIZE, OR COLOR.

NO CLAIM IS MADE TO THE EXCLUSIVE RIGHT TO USE "AMERICAN", APART FROM THE MARK AS SHOWN.

FOR ENTERTAINMENT, NAMELY, LIVE MUSIC CONCERTS; MUSIC PUBLISHING SERVICES; PRODUCTION OF SOUND AND MUSIC VIDEO RECORDINGS (U.S. CLS. 100, 101 AND 107).

JAMES LOVELACE, EXAMINING ATTORNEY

SN 85-156,393. GONZALES MD, ANGELA L. DBA RENAISSANCE MIND, RIVERSIDE, CA. FILED 10-20-2010.



THE COLOR(S) BURGUNDY AND GRAY IS/ARE CLAIMED AS A FEATURE OF THE MARK.

THE MARK CONSISTS OF A GRAY HEAD, GRAY NECK, TWO BURGUNDY RINGS AROUND THE HEAD, THE WORD "RENAISSANCE" IS BURGUNDY AND THE WORD "MIND" IS GRAY.

FOR EDUCATION SERVICES, NAMELY, PROVIDING MENTORING, TUTORING, CLASSES, SEMINARS AND WORKSHOPS IN THE FIELD OF NON-PHARMACEUTICAL CORRECTION FOR INDIVIDUALS WITH DYSLLEXIA, ADD/ADHD, DYSCALCULIA, AND DYSGRAPHIA (U.S. CLS. 100, 101 AND 107).

FIRST USE 10-30-2009; IN COMMERCE 10-30-2009.  
DORITT L. CARROLL, EXAMINING ATTORNEY

SN 85-156,448. JENNIFER L. BIERMAN, DBA PHOTOJENIC, LAGUNA NIGUEL, CA. FILED 10-19-2010.

THE MARK CONSISTS OF THE WORD "PHOTOJENIC" IN STYLIZED FONT. THE LETTERS "JEN" ARE BOLD AND THE DOT OF THE "J" IS A STAR.

FOR PHOTOGRAPHY SERVICES (U.S. CLS. 100, 101 AND 107).

FIRST USE 1-1-2001; IN COMMERCE 1-1-2001.  
YAT SYE, LEE, EXAMINING ATTORNEY

**CLASS 41—(Continued).**

SN 85-156,493. ALAN HENDERSON, BAREFOOT BEACH, FL. FILED 10-19-2010.

**TEN FEET PRODUCTIONS**

THE MARK CONSISTS OF STANDARD CHARACTERS WITHOUT CLAIM TO ANY PARTICULAR FONT, STYLE, SIZE, OR COLOR.

NO CLAIM IS MADE TO THE EXCLUSIVE RIGHT TO USE "PRODUCTIONS", APART FROM THE MARK AS SHOWN.

FOR ENTERTAINMENT SERVICES IN THE NATURE OF CREATION, DEVELOPMENT, AND PRODUCTION OF TELEVISION PROGRAMMING (U.S. CLS. 100, 101 AND 107).

KATHRYN COWARD, EXAMINING ATTORNEY

SN 85-156,504. INTERNATIONAL INSTITUTE FOR CORRECTIVE MUSCLE THERAPY, INC., SAN ANSELMO, CA. FILED 10-19-2010.

**CROSSFIBER CORRECTIVE MUSCLE THERAPY**

THE MARK CONSISTS OF STANDARD CHARACTERS WITHOUT CLAIM TO ANY PARTICULAR FONT, STYLE, SIZE, OR COLOR.

NO CLAIM IS MADE TO THE EXCLUSIVE RIGHT TO USE "CORRECTIVE MUSCLE THERAPY", APART FROM THE MARK AS SHOWN.

FOR EDUCATION SERVICES, NAMELY, PROVIDING CLASSES TEACHING SPECIFIC TECHNIQUES ON PROVIDING MUSCLE THERAPY, FOCUSING ON THE CORRECTION OF SERIOUS MUSCULAR CONDITIONS, AS WELL AS EVERYDAY ACHEs AND PAINS (U.S. CLS. 100, 101 AND 107).

FIRST USE 8-1-2010; IN COMMERCE 8-1-2010.  
ALICE BENMAMAN, EXAMINING ATTORNEY

SN 85-156,546. CENTSLESS PICTURES, 3B, NY. FILED 10-19-2010.

**Centsless Pictures**

THE MARK CONSISTS OF STANDARD CHARACTERS WITHOUT CLAIM TO ANY PARTICULAR FONT, STYLE, SIZE, OR COLOR.

NO CLAIM IS MADE TO THE EXCLUSIVE RIGHT TO USE "PICTURES", APART FROM THE MARK AS SHOWN.

FOR VIDEO EDITING; VIDEO PRODUCTION SERVICES (U.S. CLS. 100, 101 AND 107).

FIRST USE 1-1-2010; IN COMMERCE 5-1-2010.  
EMILY CHUO, EXAMINING ATTORNEY

**CLASS 41—(Continued).**

SN 85-156,561. FIVE HATS PRODUCTIONS, INC., SAINT PETERSBURG, FL. FILED 10-19-2010.

## Funky Seeds

THE MARK CONSISTS OF STANDARD CHARACTERS WITHOUT CLAIM TO ANY PARTICULAR FONT, STYLE, SIZE, OR COLOR.

FOR ENTERTAINMENT, NAMELY, LIVE PERFORMANCES BY A MUSICAL BAND (U.S. CLS. 100, 101 AND 107).

FIRST USE 10-1-2009; IN COMMERCE 10-1-2009.  
BRIAN CALLAGHAN, EXAMINING ATTORNEY

---

SN 85-156,918. GREATER MIAMI JEWISH FEDERATION, INC., MIAMI, FL. FILED 10-20-2010.

## THE COMMUNITY POST

THE MARK CONSISTS OF STANDARD CHARACTERS WITHOUT CLAIM TO ANY PARTICULAR FONT, STYLE, SIZE, OR COLOR.

NO CLAIM IS MADE TO THE EXCLUSIVE RIGHT TO USE "COMMUNITY", APART FROM THE MARK AS SHOWN.

FOR PROVIDING CURRENT EVENT NEWS AND INFORMATION VIA A GLOBAL COMPUTER NETWORK (U.S. CLS. 100, 101 AND 107).

TEJBIR SINGH, EXAMINING ATTORNEY

---

SN 85-157,473. GONZALES MD, ANGELA L, DBA RENAISSANCE MIND, RIVERSIDE, CA. FILED 10-20-2010.

## RENAISSANCE MIND

THE MARK CONSISTS OF STANDARD CHARACTERS WITHOUT CLAIM TO ANY PARTICULAR FONT, STYLE, SIZE, OR COLOR.

FOR EDUCATION SERVICES, NAMELY, PROVIDING MENTORING, TUTORING, CLASSES, SEMINARS AND WORKSHOPS IN THE FIELD OF NON-PHARMACEUTICAL CORRECTION FOR INDIVIDUALS WITH DYSLEXIA, ADD/ADHD, DYSCALCULIA, AND DYSGRAPHIA (U.S. CLS. 100, 101 AND 107).

FIRST USE 10-30-2009; IN COMMERCE 10-30-2009.  
DORITT L. CARROLL, EXAMINING ATTORNEY

**CLASS 41—(Continued).**

SN 85-157,487. APHRODITE HOLDINGS, INC., CHICAGO, IL. FILED 10-20-2010.



THE NAME(S), PORTRAIT(S), AND/OR SIGNATURE(S) SHOWN IN THE MARK IDENTIFIES "ALEKSANDRA" EFIMOVA, WHOSE CONSENT(S) TO REGISTER IS MADE OF RECORD.

THE MARK CONSISTS OF STYLIZED WORD "ALEKSANDRA".

FOR EDUCATIONAL SERVICES, NAMELY, SEMINARS ON THE TOPICS OF INJURY PREVENTION, RETAIL STORE OPERATIONS, AND THE BUSINESS OF DANCE APPAREL MERCHANDISING (U.S. CLS. 100, 101 AND 107).

FIRST USE 8-2-2005; IN COMMERCE 8-2-2005.  
JEFFREY LOOK, EXAMINING ATTORNEY

---

SN 85-157,538. PECHANGA DEVELOPMENT CORPORATION, TEMECULA, CA. FILED 10-20-2010.

## SLOT WARS

THE MARK CONSISTS OF STANDARD CHARACTERS WITHOUT CLAIM TO ANY PARTICULAR FONT, STYLE, SIZE, OR COLOR.

NO CLAIM IS MADE TO THE EXCLUSIVE RIGHT TO USE "SLOT", APART FROM THE MARK AS SHOWN.

FOR PROVIDING A WEB-BASED SYSTEM AND ON-LINE PORTAL FOR CUSTOMERS TO PARTICIPATE IN ON-LINE COMPETITION THROUGH A SOCIAL GAME PLATFORM (U.S. CLS. 100, 101 AND 107).

FIRST USE 9-16-2010; IN COMMERCE 9-16-2010.  
PRISCILLA MILTON, EXAMINING ATTORNEY



**CLASS 41—(Continued).**

SN 85-157,916. PEREZ, DANIEL, LOPATCONG, NJ. FILED 10-21-2010.



NO CLAIM IS MADE TO THE EXCLUSIVE RIGHT TO USE "YOUTH LEAGUE SOCCER", APART FROM THE MARK AS SHOWN.

THE MARK CONSISTS OF THE STYLIZED LETTERS AND WORDS "YLS YOUTH LEAGUE SOCCER". AN IMAGE OF A ROUNDED RECTANGLE WITH A YOUTH SOCCER PLAYER WITH A BALL INSIDE ABOVE THE LETTERS "YLS".

FOR AMATEUR YOUTH SPORTS SERVICES, NAMELY, ORGANIZING AND PROVIDING YOUTH SPORTS ACTIVITIES; ENTERTAINMENT IN THE NATURE OF SOCCER GAMES (U.S. CLS. 100, 101 AND 107).  
DAWN FELDMAN, EXAMINING ATTORNEY

---

SN 85-157,950. SIDMAN, JESSICA, APT 502, DC. FILED 10-21-2010.

**THE FROZEN FIX**

THE MARK CONSISTS OF STANDARD CHARACTERS WITHOUT CLAIM TO ANY PARTICULAR FONT, STYLE, SIZE, OR COLOR.

NO CLAIM IS MADE TO THE EXCLUSIVE RIGHT TO USE "FROZEN", APART FROM THE MARK AS SHOWN.

FOR ON-LINE JOURNALS, NAMELY, BLOGS FEATURING ICE CREAM, SORBET, FROZEN YOGURT, ICE POPS, AND ICE CREAM DRINKS (U.S. CLS. 100, 101 AND 107).

FIRST USE 4-19-2010; IN COMMERCE 4-19-2010.  
EDWARD NELSON, EXAMINING ATTORNEY

**CLASS 41—(Continued).**

SN 85-158,551. TWENTIETH CENTURY FOX FILM CORPORATION, LOS ANGELES, CA. FILED 10-21-2010.

**CHICKS DIG THE FASTBALL**

THE MARK CONSISTS OF STANDARD CHARACTERS WITHOUT CLAIM TO ANY PARTICULAR FONT, STYLE, SIZE, OR COLOR.

FOR ENTERTAINMENT SERVICES, NAMELY, PROVISION OF ON-GOING MULTIMEDIA PROGRAMS IN THE FIELD OF SPORTS AND ENTERTAINMENT DISTRIBUTED VIA VARIOUS PLATFORMS ACROSS MULTIPLE FORMS OF TRANSMISSION MEDIA; PROVIDING ON-LINE INFORMATION IN THE FIELD OF SPORTS AND ENTERTAINMENT; ENTERTAINMENT SERVICES IN THE NATURE OF NON-DOWNLOADABLE VIDEOS AND IMAGES FEATURING TELEVISION SHOWS ABOUT SPORTS AND ENTERTAINMENT TRANSMITTED VIA THE INTERNET AND WIRELESS COMMUNICATION NETWORKS; ON-LINE JOURNALS, NAMELY, BLOGS FEATURING PERSONAL OPINIONS IN THE FIELD OF GENERAL INTEREST, SPORTS AND ENTERTAINMENT (U.S. CLS. 100, 101 AND 107).

ANDREW RHIM, EXAMINING ATTORNEY

---

SN 85-158,797. AMERICAN CITY BUSINESS JOURNALS INC., CHARLOTTE, NC. FILED 10-22-2010.

**SUNSHINE CLASSIC**

THE MARK CONSISTS OF STANDARD CHARACTERS WITHOUT CLAIM TO ANY PARTICULAR FONT, STYLE, SIZE, OR COLOR.

NO CLAIM IS MADE TO THE EXCLUSIVE RIGHT TO USE "CLASSIC", APART FROM THE MARK AS SHOWN.

FOR ORGANIZING SPORTING EVENTS, NAMELY, LACROSSE GAMES, LACROSSE TOURNAMENTS AND LACROSSE COMPETITIONS (U.S. CLS. 100, 101 AND 107).

ALYSSA STEEL, EXAMINING ATTORNEY

---

SN 85-159,459. BODYBUILDING.COM, LLC., MERIDIAN, ID. FILED 10-22-2010.

**LIFT LIFE**

THE MARK CONSISTS OF STANDARD CHARACTERS WITHOUT CLAIM TO ANY PARTICULAR FONT, STYLE, SIZE, OR COLOR.

FOR PROVIDING FITNESS INFORMATION VIA AN ONLINE WEBSITE (U.S. CLS. 100, 101 AND 107).

JAMES GRIFFIN, EXAMINING ATTORNEY

**CLASS 41—(Continued).**

SN 85-159,472. BODYBUILDING.COM, LLC., MERIDIAN, ID. FILED 10-22-2010.

**YOUR CHANGE AGENT**

THE MARK CONSISTS OF STANDARD CHARACTERS WITHOUT CLAIM TO ANY PARTICULAR FONT, STYLE, SIZE, OR COLOR.

FOR PROVIDING FITNESS INFORMATION VIA AN ONLINE WEBSITE (U.S. CLS. 100, 101 AND 107).  
JAMES GRIFFIN, EXAMINING ATTORNEY

---

SN 85-159,490. LATEEF, NADYA, BERKELEY, CA. FILED 10-22-2010.

**Breaking Ground Productions**

THE MARK CONSISTS OF STANDARD CHARACTERS WITHOUT CLAIM TO ANY PARTICULAR FONT, STYLE, SIZE, OR COLOR.

NO CLAIM IS MADE TO THE EXCLUSIVE RIGHT TO USE "PRODUCTIONS", APART FROM THE MARK AS SHOWN.

FOR ENTERTAINMENT SERVICES, NAMELY, ARRANGING AND CONDUCTING SOCIAL ENTERTAINMENT EVENTS, CONCERTS, AND ENTERTAINMENT FASHION SHOWS (U.S. CLS. 100, 101 AND 107).

KATHERINE CHANG, EXAMINING ATTORNEY

---

SN 85-159,591. HOFFMAN, BRAD S, DBA SPRINGBOARD ADVENTURES, NEW YORK, NY. FILED 10-22-2010.

**Springboard Adventures**

THE MARK CONSISTS OF STANDARD CHARACTERS WITHOUT CLAIM TO ANY PARTICULAR FONT, STYLE, SIZE, OR COLOR.

OWNER OF U.S. REG. NO. 3,801,057.

NO CLAIM IS MADE TO THE EXCLUSIVE RIGHT TO USE "ADVENTURES", APART FROM THE MARK AS SHOWN.

FOR EDUCATIONAL SERVICES OUTSIDE OF THE TYPICAL CLASSROOM, NAMELY, GUIDED TOURS OF MUSEUMS HISTORICAL SITES AND RECREATIONAL SITES, FIELD TRIPS AND EDUCATIONAL ACTIVITIES IN THE NATURE OF SMALL AND LARGE GROUP DISCUSSIONS AND COACHING SESSIONS IN THE FIELDS OF ART, HISTORY, MATH, TECHNOLOGY, SCIENCE, DRAMA, CULTURE, RECREATION, HUMANITIES, LANGUAGE, AND SPORTS (U.S. CLS. 100, 101 AND 107).

ANDREA HACK, EXAMINING ATTORNEY

**CLASS 41—(Continued).**

SN 85-159,657. APPLEBY, DELROY, MIAMI, FL. FILED 10-23-2010.

**SCOTCH BONNET**

THE MARK CONSISTS OF STANDARD CHARACTERS WITHOUT CLAIM TO ANY PARTICULAR FONT, STYLE, SIZE, OR COLOR.

FOR RECORD AND MUSIC PRODUCTION; ENTERTAINMENT IN THE NATURE OF LIVE PERFORMANCES BY A MUSICAL ARTIST AND A MUSICAL GROUP (U.S. CLS. 100, 101 AND 107).

LINDA POWELL, EXAMINING ATTORNEY

---

SN 85-160,510. GREATER PHILADELPHIA CULTURAL ALLIANCE, PHILADELPHIA, PA. FILED 10-25-2010.

**PHILLYFUN GUIDE**

THE MARK CONSISTS OF STANDARD CHARACTERS WITHOUT CLAIM TO ANY PARTICULAR FONT, STYLE, SIZE, OR COLOR.

OWNER OF U.S. REG. NO. 3,160,763.

NO CLAIM IS MADE TO THE EXCLUSIVE RIGHT TO USE "GUIDE", APART FROM THE MARK AS SHOWN.

FOR PROVIDING A WEBSITE FEATURING INFORMATION IN THE NATURE OF AN ELECTRONIC CALENDAR OF ARTS, CULTURE, SPORTS, AND OUTDOOR EVENTS, FESTIVALS OCCURRING IN THE GREATER PHILADELPHIA REGION (U.S. CLS. 100, 101 AND 107).

FIRST USE 4-15-2009; IN COMMERCE 4-15-2009.

ANNE E. GUSTASON, EXAMINING ATTORNEY

---

SN 85-160,991. GANDER MOUNTAIN COMPANY, ST. PAUL, MN. FILED 10-26-2010.

**V RANGE**

THE MARK CONSISTS OF STANDARD CHARACTERS WITHOUT CLAIM TO ANY PARTICULAR FONT, STYLE, SIZE, OR COLOR.

NO CLAIM IS MADE TO THE EXCLUSIVE RIGHT TO USE "RANGE", APART FROM THE MARK AS SHOWN.

FOR EDUCATIONAL AND TRAINING SERVICES, NAMELY, PROVIDING CLASSES, LESSONS, AND INSTRUCTION IN THE FIELDS OF FIREARMS, FIREARM OPERATION AND SAFETY, SHOOTING, MARKSMANSHIP, TARGET PRACTICE, SELF DEFENSE, HUNTING, AND OTHER OUTDOOR SKILLS; GUN FIRING RANGES (U.S. CLS. 100, 101 AND 107).

RONALD AIKENS, EXAMINING ATTORNEY

**CLASS 41—(Continued).**

SN 85-163,427. THE MANOR MONTESSORI SCHOOL, INC., POTOMAC, MD. FILED 10-28-2010.

The Manor Montessori School

THE MARK CONSISTS OF STANDARD CHARACTERS WITHOUT CLAIM TO ANY PARTICULAR FONT, STYLE, SIZE, OR COLOR.

NO CLAIM IS MADE TO THE EXCLUSIVE RIGHT TO USE "MONTESSORI SCHOOL", APART FROM THE MARK AS SHOWN.

FOR PROVIDING COURSES OF INSTRUCTION AT THE PRESCHOOL AND ELEMENTARY SCHOOL (CHILDREN AGES 2 THROUGH 9) LEVEL (U.S. CLS. 100, 101 AND 107).

FIRST USE 2-1-1963; IN COMMERCE 2-1-1963.  
KHANH LE, EXAMINING ATTORNEY

**CLASS 41—(Continued).**

SN 85-165,436. RIOS, LILLIANA, AKA LR, BELLEVILLE, NJ. FILED 10-29-2010.



THE COLOR(S) BLACK, WHITE AND GRAY IS/ARE CLAIMED AS A FEATURE OF THE MARK.

THE MARK CONSISTS OF THE WORDING "MENCONFESS.COM" IN BLACK OUTLINED IN A WHITE BORDER WITH BLACK OUTLINING. UNDERNEATH IS THE WORDING "THE PLACE WHERE MEN COME CLEAN ABOUT THEIR DIRT" IN BLACK. ON EITHER SIDE OF THE WORDING ARE TWO MEN DRESSED IN SUITS IN BLACK AND WHITE. THE ENTIRE MARK IS ON A GRAY RECTANGULAR BACKGROUND.

FOR ON-LINE JOURNALS, NAMELY, BLOGS FEATURING CONFESSIONS MADE BY MEN; ENTERTAINMENT SERVICES, NAMELY, PROVIDING A WEBSITE FEATURING ARTICLES, COMMENTARIES, AND VIDEOS FEATURING MEMBERS OF BOTH SEXES FROM THE GENERAL PUBLIC SHARING ADVICE, EXPERIENCES, AND TIPS ABOUT LOVE, LIFE, SEX AND RELATIONSHIPS, WITH THE AFOREMENTIONED ADVICE, EXPERIENCES, AND TIPS BEING FOR ENTERTAINMENT PURPOSES ONLY (U.S. CLS. 100, 101 AND 107).

LINDSEY RUBIN, EXAMINING ATTORNEY

SN 85-164,778. MUSIC MONITOR NETWORK, INC., RALEIGH, NC. FILED 10-29-2010.



NO CLAIM IS MADE TO THE EXCLUSIVE RIGHT TO USE "METAL", APART FROM THE MARK AS SHOWN.

FOR PROVIDING A WEBSITE FEATURING INFORMATION IN THE FIELD OF MUSIC AND ENTERTAINMENT; PROVIDING INFORMATION, NEWS AND COMMENTARY IN THE FIELD OF ENTERTAINMENT (U.S. CLS. 100, 101 AND 107).

FIRST USE 10-1-2010; IN COMMERCE 10-1-2010.  
DEBRA LEE, EXAMINING ATTORNEY

SN 85-166,685. TALAE, MOHAMMADREZA, TORONTO, ONTARIO, CANADA, FILED 11-1-2010.

DORJ

THE MARK CONSISTS OF STANDARD CHARACTERS WITHOUT CLAIM TO ANY PARTICULAR FONT, STYLE, SIZE, OR COLOR.

THE ENGLISH TRANSLATION OF "DORJ" IN THE MARK IS "TREASURE BOX".

FOR REFERENCE LIBRARIES OF LITERATURE AND DOCUMENTARY RECORDS (U.S. CLS. 100, 101 AND 107).

FIRST USE 1-15-1998; IN COMMERCE 1-15-1998.  
RICHARD WHITE, EXAMINING ATTORNEY

**CLASS 41—(Continued).**

SN 85-167,027. SEBASTIEN SABATIER-CURIAL, DBA SABA, TRENTON, NJ. FILED 11-2-2010.



NO CLAIM IS MADE TO THE EXCLUSIVE RIGHT TO USE "FILMS", APART FROM THE MARK AS SHOWN.

THE COLOR(S) BLUE, BLACK, BROWN, PINK AND WHITE IS/ARE CLAIMED AS A FEATURE OF THE MARK.

THE MARK CONSISTS A DIAMOND SHAPED CARRIER DEPICTING AN ELEPHANT HEAD IN BLACK, BROWN, WHITE AND PINK WITH A WHITE TUSK SUPERIMPOSED OVER BLUE STRIPES, AND ABOVE THE ELEPHANT IS A WHITE CLOUD WITH A BLUE PYRAMID INSIDE, AND ALONG THE LEFT SIDE OF THE DIAMOND IS THE WORDING, "CLOUDY SKY FILMS" IN BLACK; OTHER THAN AS DESCRIBED THE COLOR WHITE IS NOT PART OF THE MARK BUT REPRESENTS TRANSPARENT BACKGROUND.

FOR FILM AND VIDEO FILM PRODUCTION; FILM AND VIDEO TAPE FILM PRODUCTION; FILM PRODUCTION; MEDIA PRODUCTION SERVICES, NAMELY, VIDEO AND FILM PRODUCTION; MOTION PICTURE FILM PRODUCTION; VIDEO TAPE FILM PRODUCTION (U.S. CLS. 100, 101 AND 107).  
KELLY CHOE, EXAMINING ATTORNEY

---

SN 85-167,686. HARE, DEE, LONDON, UNITED KINGDOM, FILED 11-3-2010.

**PURE PAGEANTRY**

THE MARK CONSISTS OF STANDARD CHARACTERS WITHOUT CLAIM TO ANY PARTICULAR FONT, STYLE, SIZE, OR COLOR.

NO CLAIM IS MADE TO THE EXCLUSIVE RIGHT TO USE "PAGEANTRY", APART FROM THE MARK AS SHOWN.

FOR ENTERTAINMENT IN THE NATURE OF BEAUTY PAGEANTS; PROVIDING A WEBSITE FOR ENTERTAINMENT AND INFORMATION IN THE FIELD OF BEAUTY PAGEANTS (U.S. CLS. 100, 101 AND 107).  
EDWARD NELSON, EXAMINING ATTORNEY

**CLASS 41—(Continued).**

SN 85-170,951. MCBRAYER, ERIC, SANTA CLARA, CA. FILED 11-7-2010.



THE MARK CONSISTS OF THE NUMBER 5 ENCLOSED BY THE LETTER E.

FOR PRODUCTION OF DVDS, VIDEOTAPES AND TELEVISION PROGRAMS FEATURING OUTDOOR AND SPORTING EVENTS (U.S. CLS. 100, 101 AND 107).  
ANNE MADDEN, EXAMINING ATTORNEY

---

SN 85-171,174. WINSHAPE FOUNDATION, INC., ATLANTA, GA. FILED 11-8-2010.



THE MARK CONSISTS OF THE WORD "FRESHTHING" INSIDE TWO RECTANGLES FEATURING CIRCLES THAT RESEMBLE ROOTS CONNECTED TO A PLANT ABOVE.

FOR CHARITABLE SERVICES, NAMELY, PROVIDING PROGRAMS TO ASSIST STUDENTS IN DEVELOPING THEIR CHRISTIAN DISCIPLESHIP, SOCIAL SKILLS, AND LEADERSHIP ABILITIES (U.S. CLS. 100, 101 AND 107).  
FIRST USE 2-4-2008; IN COMMERCE 2-4-2008.  
DAVID C. REIHNER, EXAMINING ATTORNEY

**CLASS 41—(Continued).**

SN 85-171,183. WINSHAPE FOUNDATION, INC., ATLANTA, GA. FILED 11-8-2010.



THE MARK CONSISTS OF THE WORDS "THE DREAM CASTING TRIP" SUPERIMPOSED OVER A THUMB PRINT, ALL ABOVE A DEPICTION OF THE LINCOLN MEMORIAL WITH BUSHES AND BIRDS.

FOR CHARITABLE SERVICES, NAMELY, PROVIDING PROGRAMS TO ASSIST STUDENTS IN DEVELOPING THEIR CHRISTIAN DISCIPLESHIP, SOCIAL SKILLS, AND LEADERSHIP ABILITIES (U.S. CLS. 100, 101 AND 107).

FIRST USE 2-4-2008; IN COMMERCE 2-4-2008.  
DAVID C. REIHNER, EXAMINING ATTORNEY

**CLASS 41—(Continued).**

SN 85-172,507. BAY HEAD YACHT CLUB, BAY HEAD, NJ. FILED 11-9-2010.



THE MARK CONSISTS OF A FLAG ON A FLAGPOLE, WITH THE FLAG BEING IN THE SHAPE OF A TRIANGLE WITH A STAR IN THE MIDDLE.

FOR YACHT CLUB SERVICES; SOCIAL CLUB SERVICES, NAMELY, ARRANGING, ORGANIZING AND HOSTING SOCIAL EVENTS, GET-TOGETHERS AND PARTIES FOR CLUB MEMBERS (U.S. CLS. 100, 101 AND 107).

FIRST USE 6-15-2010; IN COMMERCE 6-15-2010.  
PRISCILLA MILTON, EXAMINING ATTORNEY

SN 85-171,193. WINSHAPE FOUNDATION, INC., ATLANTA, GA. FILED 11-8-2010.



NO CLAIM IS MADE TO THE EXCLUSIVE RIGHT TO USE "COLLEGE PROGRAM", APART FROM THE MARK AS SHOWN.

THE MARK CONSISTS OF THE WORDS "WINSHAPE COLLEGE PROGRAM" IN A BANNER BELOW A DEPICTION OF A DROP OF WATER FALLING INTO A SERIES OF RIPPLES.

FOR CHARITABLE SERVICES, NAMELY, PROVIDING PROGRAMS TO ASSIST STUDENTS IN DEVELOPING THEIR CHRISTIAN DISCIPLESHIP, SOCIAL SKILLS, AND LEADERSHIP ABILITIES (U.S. CLS. 100, 101 AND 107).

FIRST USE 8-1-2005; IN COMMERCE 8-15-2005.  
DAVID C. REIHNER, EXAMINING ATTORNEY

SN 85-172,547. BAY HEAD YACHT CLUB, BAY HEAD, NJ. FILED 11-9-2010.



THE MARK CONSISTS OF A FLAG ON A FLAGPOLE, WITH THE FLAG BEING IN THE SHAPE OF A TRIANGLE WITH A STAR IN THE MIDDLE, IN A BLACK CIRCLE WITH A WHITE BORDER.

FOR YACHT CLUB SERVICES; SOCIAL CLUB SERVICES, NAMELY, ARRANGING, ORGANIZING AND HOSTING SOCIAL EVENTS, GET-TOGETHERS AND PARTIES FOR CLUB MEMBERS (U.S. CLS. 100, 101 AND 107).

FIRST USE 7-1-1988; IN COMMERCE 7-1-1988.  
PRISCILLA MILTON, EXAMINING ATTORNEY

**CLASS 41—(Continued).**

SN 85-172,556. SCHOOL IMPROVEMENT NETWORK, INC., MIDVALE, UT. FILED 11-9-2010.

## Livebook

THE MARK CONSISTS OF STANDARD CHARACTERS WITHOUT CLAIM TO ANY PARTICULAR FONT, STYLE, SIZE, OR COLOR.

FOR EDUCATION SERVICES, NAMELY, PROVIDING LIVE AND ON-LINE INSTRUCTION IN THE FIELD OF PROFESSIONAL DEVELOPMENT (U.S. CLS. 100, 101 AND 107).

CAROL SPILS, EXAMINING ATTORNEY

---

SN 85-172,561. SCHOOL IMPROVEMENT NETWORK, INC., MIDVALE, UT. FILED 11-9-2010.

## Livebooks

THE MARK CONSISTS OF STANDARD CHARACTERS WITHOUT CLAIM TO ANY PARTICULAR FONT, STYLE, SIZE, OR COLOR.

FOR EDUCATION SERVICES, NAMELY, PROVIDING LIVE AND ON-LINE INSTRUCTION IN THE FIELD OF PROFESSIONAL DEVELOPMENT (U.S. CLS. 100, 101 AND 107).

CAROL SPILS, EXAMINING ATTORNEY

---

SN 85-172,566. SCHOOL IMPROVEMENT NETWORK, INC., MIDVALE, UT. FILED 11-9-2010.

## Livebooks 360

THE MARK CONSISTS OF STANDARD CHARACTERS WITHOUT CLAIM TO ANY PARTICULAR FONT, STYLE, SIZE, OR COLOR.

FOR EDUCATION SERVICES, NAMELY, PROVIDING LIVE AND ON-LINE INSTRUCTION IN THE FIELD OF PROFESSIONAL DEVELOPMENT (U.S. CLS. 100, 101 AND 107).

CAROL SPILS, EXAMINING ATTORNEY

**CLASS 41—(Continued).**

SN 85-172,570. SCHOOL IMPROVEMENT NETWORK, INC., MIDVALE, UT. FILED 11-9-2010.

## Livebook 360

THE MARK CONSISTS OF STANDARD CHARACTERS WITHOUT CLAIM TO ANY PARTICULAR FONT, STYLE, SIZE, OR COLOR.

FOR EDUCATION SERVICES, NAMELY, PROVIDING LIVE AND ON-LINE INSTRUCTION IN THE FIELD OF PROFESSIONAL DEVELOPMENT (U.S. CLS. 100, 101 AND 107).

CAROL SPILS, EXAMINING ATTORNEY

---

SN 85-172,850. YOUSUFZAI, MUSTAFA, BRIARCLIFF MANOR, NY. AND BARAK, REZA, BRIARCLIFF MANOR, NY. AND BARAK, FARDEEN, BRIARCLIFF MANOR, NY. FILED 11-9-2010.

## NINE BRIDGES

THE MARK CONSISTS OF STANDARD CHARACTERS WITHOUT CLAIM TO ANY PARTICULAR FONT, STYLE, SIZE, OR COLOR.

FOR MULTIMEDIA ENTERTAINMENT SERVICES IN THE NATURE OF RECORDING, PRODUCTION AND POST-PRODUCTION SERVICES IN THE FIELDS OF MUSIC, VIDEO, AND FILMS (U.S. CLS. 100, 101 AND 107).

MARILYN IZZI, EXAMINING ATTORNEY

---

SN 85-172,941. VALLEY FEVER SURVIVOR LLC, WOODINVILLE, WA. FILED 11-9-2010.



THE COLOR(S) BLACK, WHITE, RED, ORANGE, YELLOW, GREEN, PURPLE, AND BLUE IN THE PICTURE IS/ARE CLAIMED AS A FEATURE OF THE MARK.

THE MARK CONSISTS OF THE SEMICIRCULAR SHAPED DESERT SCENE WITH NINE BLACK QUAIL

**CLASS 41—(Continued).**

WALKING AT THE LOWER-MIDDLE OF THE SCENE, CACTI WITH GREEN, YELLOW, BLACK, AND PURPLE SHADING, AND YELLOW AND ORANGE SAND WITH A BLUE SKY WITH WHITE CLOUDS. A SEMI-TRANSPARENT ORANGE FADES OVER THIS SCENE FROM THE CENTER TO BECOME MORE ORANGE AND RED AT THE EDGES AND TO DISPLAY LESS OF THE DESERT SCENE AT THE OUTER RIGHT AND LEFT EDGES. SOME OF THE CACTI EXTEND SLIGHTLY BEYOND THE LOWER EDGE OF THE SEMICIRCULAR SHAPE.

FOR MULTIMEDIA PUBLISHING OF BOOKS, MAGAZINES, JOURNALS, SOFTWARE, GAMES, MUSIC, AND ELECTRONIC PUBLICATIONS (U.S. CLS. 100, 101 AND 107).

FIRST USE 9-7-2009; IN COMMERCE 11-28-2009.  
MICHAEL ENGEL, EXAMINING ATTORNEY

---

SN 85-173,708. THE MAJESTIC STAR CASINO, LLC, GARY, IN. FILED 11-10-2010.

**THE BACC ROOM**

THE MARK CONSISTS OF STANDARD CHARACTERS WITHOUT CLAIM TO ANY PARTICULAR FONT, STYLE, SIZE, OR COLOR.

FOR CASINO SERVICES (U.S. CLS. 100, 101 AND 107).  
GINA FINK, EXAMINING ATTORNEY

---

SN 85-173,723. KB MEDIA GROUP, LLC, SAN FRANCISCO, CA. FILED 11-10-2010.

**MASTER KUSH**

THE MARK CONSISTS OF STANDARD CHARACTERS WITHOUT CLAIM TO ANY PARTICULAR FONT, STYLE, SIZE, OR COLOR.

FOR ENTERTAINMENT SERVICES, NAMELY, THE PROVISION OF CONTINUING PROGRAMS FEATURING ANIMATION DELIVERED BY INTERNET (U.S. CLS. 100, 101 AND 107).

FIRST USE 1-0-2007; IN COMMERCE 1-0-2007.  
ANGELA DUONG, EXAMINING ATTORNEY

**CLASS 41—(Continued).**

SN 85-174,140. BE PHYSIQUE, OAKLAND, CA. FILED 11-11-2010.

**BARLATES**

THE MARK CONSISTS OF STANDARD CHARACTERS WITHOUT CLAIM TO ANY PARTICULAR FONT, STYLE, SIZE, OR COLOR.

FOR HEALTH CLUB SERVICES, NAMELY, PROVIDING INSTRUCTION AND EQUIPMENT IN THE FIELD OF PHYSICAL EXERCISE (U.S. CLS. 100, 101 AND 107).  
SHAUNIA CARLYLE, EXAMINING ATTORNEY

---

SN 85-174,710. CLAFLIN, SCOTT, CUYAHHOGA FALLS, OH. FILED 11-11-2010.

**Americans On The Streets**

THE MARK CONSISTS OF STANDARD CHARACTERS WITHOUT CLAIM TO ANY PARTICULAR FONT, STYLE, SIZE, OR COLOR.

FOR ENTERTAINMENT IN THE NATURE OF ONGOING TELEVISION PROGRAMS IN THE FIELDS OF FINANCE AND COMEDY (U.S. CLS. 100, 101 AND 107).  
EUGENIA MARTIN, EXAMINING ATTORNEY

---

SN 85-174,936. BRATS IN BROADCASTING LLC, PEORIA, AZ. FILED 11-11-2010.

**BRATCONRADIO.COM**

THE MARK CONSISTS OF STANDARD CHARACTERS WITHOUT CLAIM TO ANY PARTICULAR FONT, STYLE, SIZE, OR COLOR.

FOR ENTERTAINMENT SERVICES, NAMELY, PROVIDING RADIO PROGRAMS IN THE FIELD OF INTERACTIVE TALK SHOWS COVERING LIFE AS CHILDREN OF GOVERNMENT AND MILITARY SERVICE MEMBERS (U.S. CLS. 100, 101 AND 107).

TAMARA FRAZIER, EXAMINING ATTORNEY

**CLASS 41—(Continued).**

SN 85-174,954. LIVE NATION WORLDWIDE, INC., BEVERLY HILLS, CA. FILED 11-11-2010.

**ARTIST NATION**

THE MARK CONSISTS OF STANDARD CHARACTERS WITHOUT CLAIM TO ANY PARTICULAR FONT, STYLE, SIZE, OR COLOR.

FOR PRODUCTION OF LIVE ENTERTAINMENT EVENTS, NAMELY, LIVE MUSICAL CONCERTS AND FESTIVALS; ARRANGING FOR TICKET RESERVATIONS FOR LIVE ENTERTAINMENT EVENTS; PROVIDING INFORMATION IN THE FIELD OF ENTERTAINMENT; FAN CLUB SERVICES; RECORDING, PRODUCTION AND POST-PRODUCTION SERVICES IN THE FIELDS OF MUSIC, VIDEO AND MOTION PICTURES; MUSIC PUBLISHING SERVICES (U.S. CLS. 100, 101 AND 107).

RAUL CORDOVA, EXAMINING ATTORNEY

SN 85-175,182. SUMMA HEALTH SYSTEM, AKRON, OH. FILED 11-12-2010.

**BLOSSOM & BLOOM**

THE MARK CONSISTS OF STANDARD CHARACTERS WITHOUT CLAIM TO ANY PARTICULAR FONT, STYLE, SIZE, OR COLOR.

FOR ON-LINE ELECTRONIC NEWSLETTERS DELIVERED BY E-MAIL IN THE FIELD OF HEALTH AND WELLNESS FOR WOMEN (U.S. CLS. 100, 101 AND 107).

SUNG IN, EXAMINING ATTORNEY

SN 85-175,230. PIQUET, CRISTIANO, MIAMI, FL. FILED 11-12-2010.

**PIQUET UNIVERSITY**

THE MARK CONSISTS OF STANDARD CHARACTERS WITHOUT CLAIM TO ANY PARTICULAR FONT, STYLE, SIZE, OR COLOR.

NO CLAIM IS MADE TO THE EXCLUSIVE RIGHT TO USE "UNIVERSITY", APART FROM THE MARK AS SHOWN.

FOR EDUCATION SERVICES, NAMELY, PROVIDING ON-LINE CLASSES AND TUTORIALS IN THE FIELD OF REAL ESTATE, REAL ESTATE INVESTING AND REAL ESTATE SALES AND BROKERAGE; EDUCATIONAL SERVICES, NAMELY, CONDUCTING WORKSHOPS AND SEMINARS IN THE FIELDS OF REAL ESTATE, REAL ESTATE INVESTING AND REAL ESTATE SALES AND BROKERAGE AND DISTRIBUTION OF TRAINING MATERIALS IN CONNECTION THEREWITH (U.S. CLS. 100, 101 AND 107).

INGRID C. EULIN, EXAMINING ATTORNEY

**CLASS 41—(Continued).**

SN 85-175,235. MARY KAY INC., ADDISON, TX. FILED 11-12-2010.

**INSPIRE YOUR WAY TO THE TOP**

THE MARK CONSISTS OF STANDARD CHARACTERS WITHOUT CLAIM TO ANY PARTICULAR FONT, STYLE, SIZE, OR COLOR.

FOR EDUCATIONAL SERVICES, NAMELY, CONDUCTING CLASSES, SEMINARS, CONFERENCES AND WORKSHOPS IN THE FIELD OF DIRECT SALES OF COSMETICS, BEAUTY PRODUCTS, SKIN CARE PRODUCTS AND PERSONAL CARE PRODUCTS AND DISTRIBUTION OF COURSE MATERIAL IN CONNECTION THEREWITH (U.S. CLS. 100, 101 AND 107).

MICHAEL ENGEL, EXAMINING ATTORNEY

SN 85-175,269. PIQUET, CRISTIANO, MIAMI, FL. FILED 11-12-2010.

**PIQUET RACING**

THE MARK CONSISTS OF STANDARD CHARACTERS WITHOUT CLAIM TO ANY PARTICULAR FONT, STYLE, SIZE, OR COLOR.

NO CLAIM IS MADE TO THE EXCLUSIVE RIGHT TO USE "RACING", APART FROM THE MARK AS SHOWN.

FOR ENTERTAINMENT IN THE NATURE OF AUTOMOBILE RACES; ENTERTAINMENT SERVICES IN THE NATURE OF AUTOMOBILE RACING AND EXHIBITIONS; ENTERTAINMENT SERVICES, NAMELY, PARTICIPATION IN SPORTS CAR RACES (U.S. CLS. 100, 101 AND 107).

INGRID C. EULIN, EXAMINING ATTORNEY

SN 85-175,316. BEECH PROPERTIES, INC., TROY, MI. FILED 11-12-2010.



THE MARK CONSISTS OF THE WORDS EXCITE-A-BOWL IN BLOCK LETTERS, IN A CURVED FORMATION, WITH A LARGER "X" IN THE WORD EXCITE AND A BOWLING BALL IMAGE IN PLACE OF THE "O" IN THE WORD BOWL, THE BOWLING BALL BEING SURROUNDED BY A SUNBURST IMAGE.

FOR BOWLING ALLEYS; PROVIDING BOWLING ALLEYS (U.S. CLS. 100, 101 AND 107).

FIRST USE 7-1-2002; IN COMMERCE 7-1-2002.

NAKWAMA ANKRAH, EXAMINING ATTORNEY



**CLASS 41—(Continued).**

SN 85-175,410. SYMMYS LLC, NEW YORK, NY. FILED 11-12-2010.

**The Only Heavily  
Quantitative,  
Omni-Comprehensive,  
Intensive Buy-Side Bootcamp**

THE MARK CONSISTS OF STANDARD CHARACTERS WITHOUT CLAIM TO ANY PARTICULAR FONT, STYLE, SIZE, OR COLOR.

FOR EDUCATIONAL SERVICES, NAMELY, CONDUCTING CLASSES, SEMINARS, CONFERENCES AND WORKSHOPS IN THE FIELD OF QUANTITATIVE RISK AND PORTFOLIO MANAGEMENT AND DISTRIBUTION OF COURSE AND EDUCATIONAL MATERIALS IN CONNECTION THEREWITH ; EDUCATIONAL SERVICES, NAMELY, PROVIDING CLASSES, SEMINARS, CONFERENCES AND WORKSHOPS IN THE FIELDS OF QUANTITATIVE RISK AND PORTFOLIO MANAGEMENT (U.S. CLS. 100, 101 AND 107).

FIRST USE 2-1-2008; IN COMMERCE 2-1-2008.  
REBECCA SMITH, EXAMINING ATTORNEY

**CLASS 41—(Continued).**

SN 85-175,710. BERTINO, BRYAN, BEVERLY HILLS, CA. FILED 11-12-2010.

**UNBROKEN PICTURES**

THE MARK CONSISTS OF STANDARD CHARACTERS WITHOUT CLAIM TO ANY PARTICULAR FONT, STYLE, SIZE, OR COLOR.

NO CLAIM IS MADE TO THE EXCLUSIVE RIGHT TO USE "PICTURES", APART FROM THE MARK AS SHOWN. FOR ENTERTAINMENT MEDIA PRODUCTION SERVICES FOR MOTION PICTURES, TELEVISION AND INTERNET; ENTERTAINMENT SERVICES IN THE NATURE OF CREATION, DEVELOPMENT, AND PRODUCTION OF TELEVISION PROGRAMMING; MOTION PICTURE FILM PRODUCTION; PRODUCTION OF TELEVISION PROGRAMS (U.S. CLS. 100, 101 AND 107).  
JEFF DEFORD, EXAMINING ATTORNEY

SN 85-175,952. KASUN LLC, ALBUQUERQUE, NM. FILED 11-12-2010.

**NO FLOP PINEAPPLE**

THE MARK CONSISTS OF STANDARD CHARACTERS WITHOUT CLAIM TO ANY PARTICULAR FONT, STYLE, SIZE, OR COLOR.

FOR ENTERTAINMENT SERVICES, NAMELY PROVIDING A LIVE GAME OF CHANCE IN A CASINO (U.S. CLS. 100, 101 AND 107).

FIRST USE 8-29-2008; IN COMMERCE 3-0-2009.  
PATRICIA EVANKO, EXAMINING ATTORNEY

SN 85-175,693. SUPERSTATION, INC., ATLANTA, GA. FILED 11-12-2010.

**TURN HERE FOR FUN**

SN 85-176,208. LILSPROUT PRESS, LLC, SAN FRANCISCO, CA. FILED 11-13-2010.

**LILSPROUT**

THE MARK CONSISTS OF STANDARD CHARACTERS WITHOUT CLAIM TO ANY PARTICULAR FONT, STYLE, SIZE, OR COLOR.

FOR ENTERTAINMENT SERVICES IN THE NATURE OF MOVIES, ON-GOING TELEVISION PROGRAMS, ON-GOING TELEVISION SERIES AND ON-GOING INTERSTITIAL TELEVISION PROGRAM SEGMENTS FEATURING MOVIES AND TELEVISION PROGRAMMING IN THE FIELD OF COMEDY, DRAMA, SPORTS, ACTION, OR ADVENTURE PROVIDED THROUGH BROADCAST TELEVISION AND VIA GLOBAL COMPUTER NETWORKS; TELEVISION SHOW PRODUCTION SERVICES; DISTRIBUTION OF TELEVISION PROGRAMMING; PROVIDING ON-LINE INFORMATION IN THE FIELD OF ENTERTAINMENT (U.S. CLS. 100, 101 AND 107).  
DAVID COLLIER, EXAMINING ATTORNEY

THE MARK CONSISTS OF STANDARD CHARACTERS WITHOUT CLAIM TO ANY PARTICULAR FONT, STYLE, SIZE, OR COLOR.

FOR BOOK PUBLISHING; MULTIMEDIA PUBLISHING OF BOOKS, MAGAZINES, JOURNALS, SOFTWARE, GAMES, MUSIC, AND ELECTRONIC PUBLICATIONS; ONLINE ELECTRONIC PUBLISHING OF BOOKS AND PERIODICALS; PUBLISHING OF BOOKS, E-BOOKS, AUDIO BOOKS, MUSIC AND ILLUSTRATIONS (U.S. CLS. 100, 101 AND 107).

FIRST USE 11-12-2010; IN COMMERCE 11-12-2010.  
JAMES GRIFFIN, EXAMINING ATTORNEY

**CLASS 41—(Continued).**

SN 85-176,324. BUSINESS WOMEN RISING, INC., NEWPORT BEACH, CA. FILED 11-14-2010.

## Leadership Vistas

THE MARK CONSISTS OF STANDARD CHARACTERS WITHOUT CLAIM TO ANY PARTICULAR FONT, STYLE, SIZE, OR COLOR.

NO CLAIM IS MADE TO THE EXCLUSIVE RIGHT TO USE "LEADERSHIP", APART FROM THE MARK AS SHOWN.

FOR BUSINESS EDUCATION AND TRAINING SERVICES, NAMELY, DEVELOPING, AND FACILITATING CUSTOMIZED IN-COMPANY LEADERSHIP AND EXECUTIVE DEVELOPMENT PROGRAMS, PROVIDING EXECUTIVE COACHING SERVICES, AND PROVIDING PUBLIC AND IN-COMPANY KEYNOTE PRESENTATIONS TO BUSINESS LEADERS; EDUCATION SERVICES, NAMELY, MENTORING IN THE FIELD OF MANAGEMENT, LEADERSHIP AND EXECUTIVE DEVELOPMENT; PEER TO PEER COACHING SERVICES IN THE FIELD OF MANAGEMENT, LEADERSHIP AND EXECUTIVE DEVELOPMENT; PROVIDING EDUCATIONAL MENTORING SERVICES AND PROGRAMS IN THE FIELD OF MANAGEMENT, LEADERSHIP AND EXECUTIVE DEVELOPMENT; PROVIDING GROUP COACHING AND LEARNING FORUMS IN THE FIELD OF LEADERSHIP DEVELOPMENT (U.S. CLS. 100, 101 AND 107).

FIRST USE 2-10-2010; IN COMMERCE 3-8-2010.  
HOWARD SMIGA, EXAMINING ATTORNEY

SN 85-176,339. PUSH LIFE, INC., TORONTO, ON, CANADA, FILED 11-14-2010.

## LISTEN.IN

THE MARK CONSISTS OF STANDARD CHARACTERS WITHOUT CLAIM TO ANY PARTICULAR FONT, STYLE, SIZE, OR COLOR.

FOR ENTERTAINMENT SERVICES, NAMELY, PROVIDING NON-DOWNLOADABLE PLAYBACK OF MUSIC VIA GLOBAL COMMUNICATIONS NETWORKS (U.S. CLS. 100, 101 AND 107).

FIRST USE 10-18-2010; IN COMMERCE 10-18-2010.  
MORGAN WYNNE, EXAMINING ATTORNEY

**CLASS 41—(Continued).**

SN 85-176,512. AVE MARIA UNIVERSITY, INC., DBA AVE MARIA UNIVERSITY, AVE MARIA, FL. FILED 11-15-2010.

## Ave Maria University

THE MARK CONSISTS OF STANDARD CHARACTERS WITHOUT CLAIM TO ANY PARTICULAR FONT, STYLE, SIZE, OR COLOR.

OWNER OF U.S. REG. NOS. 2,567,854, 3,239,622 AND 3,374,342.

NO CLAIM IS MADE TO THE EXCLUSIVE RIGHT TO USE "UNIVERSITY", APART FROM THE MARK AS SHOWN.

FOR EDUCATION SERVICES IN THE NATURE OF COURSES AT THE UNIVERSITY LEVEL; ENTERTAINMENT IN THE NATURE OF COMPETITIONS IN THE FIELD OF ATHLETIC EVENTS AT THE COLLEGE AND UNIVERSITY LEVEL (U.S. CLS. 100, 101 AND 107).

FIRST USE 11-1-2004; IN COMMERCE 11-1-2004.  
STEVEN R. FINE, EXAMINING ATTORNEY

SN 85-176,553. BUSINESS WOMEN RISING, INC., NEWPORT BEACH, CA. FILED 11-15-2010.

## Stella Vista

THE MARK CONSISTS OF STANDARD CHARACTERS WITHOUT CLAIM TO ANY PARTICULAR FONT, STYLE, SIZE, OR COLOR.

FOR BUSINESS EDUCATION AND TRAINING SERVICES, NAMELY, DEVELOPING, AND FACILITATING CUSTOMIZED IN-COMPANY LEADERSHIP AND EXECUTIVE DEVELOPMENT PROGRAMS, PROVIDING EXECUTIVE COACHING SERVICES, AND PROVIDING PUBLIC AND IN-COMPANY KEYNOTE PRESENTATIONS TO BUSINESS LEADERS; EDUCATION SERVICES, NAMELY, MENTORING IN THE FIELD OF MANAGEMENT, LEADERSHIP AND EXECUTIVE DEVELOPMENT; PEER TO PEER COACHING SERVICES IN THE FIELD OF MANAGEMENT, LEADERSHIP AND EXECUTIVE DEVELOPMENT; PROVIDING EDUCATIONAL MENTORING SERVICES AND PROGRAMS IN THE FIELD OF MANAGEMENT, LEADERSHIP AND EXECUTIVE DEVELOPMENT; PROVIDING GROUP COACHING AND LEARNING FORUMS IN THE FIELD OF LEADERSHIP DEVELOPMENT (U.S. CLS. 100, 101 AND 107).

FIRST USE 6-6-2010; IN COMMERCE 6-6-2010.  
HOWARD SMIGA, EXAMINING ATTORNEY

**CLASS 41—(Continued).**

SN 85-176,574. FALLECKER, ROGER, BUTLER, PA. FILED 11-15-2010.

## SUNNY RHINO YOGA OM IS WHERE THE HEART IS

THE MARK CONSISTS OF STANDARD CHARACTERS WITHOUT CLAIM TO ANY PARTICULAR FONT, STYLE, SIZE, OR COLOR.

NO CLAIM IS MADE TO THE EXCLUSIVE RIGHT TO USE "YOGA", APART FROM THE MARK AS SHOWN.

FOR ARRANGING AND CONDUCTING SPECIAL EVENTS FOR SOCIAL ENTERTAINMENT PURPOSES; YOGA INSTRUCTION (U.S. CLS. 100, 101 AND 107).

CURTIS FRENCH, EXAMINING ATTORNEY

SN 85-176,637. ALLEN, MARC, NORTH CANTON, OH. FILED 11-15-2010.

## BLESSEDFX

THE MARK CONSISTS OF STANDARD CHARACTERS WITHOUT CLAIM TO ANY PARTICULAR FONT, STYLE, SIZE, OR COLOR.

FOR MUSIC PRODUCTION SERVICES; PHOTOGRAPHY; PHOTOGRAPHY SERVICES; VIDEO PRODUCTION SERVICES (U.S. CLS. 100, 101 AND 107).

WILLIAM BRECKENFELD, EXAMINING ATTORNEY

SN 85-176,760. FORD, STEPHEN, J., SAN DIEGO, CA. FILED 11-15-2010.

## Visions2Careers

THE MARK CONSISTS OF STANDARD CHARACTERS WITHOUT CLAIM TO ANY PARTICULAR FONT, STYLE, SIZE, OR COLOR.

FOR EDUCATIONAL AND ENTERTAINMENT SERVICES, NAMELY, PROVIDING MOTIVATIONAL SPEAKING SERVICES IN THE FIELD OF CAREER EXPLORATION, PREPARATION, EMPLOYABILITY AND SUCCESSFUL LIFETIME APPLICATION OF INTERESTS AND TALENTS; ENTERTAINMENT SERVICES, NAMELY, PROVIDING A WEB SITE FEATURING PHOTOGRAPHIC, AUDIO, VIDEO AND PROSE PRESENTATIONS FEATURING SUBJECT MATTER RELATED TO CAREERS AND EXPLORATION OF VARIETY OF PATHWAYS FOR LIFETIME CHOICES AND PREPARATION FOR CAREER READINESS AND LIFETIME LEARNING (U.S. CLS. 100, 101 AND 107).

FIRST USE 10-18-2010; IN COMMERCE 10-18-2010.

PAM WILLIS, EXAMINING ATTORNEY

**CLASS 41—(Continued).**

SN 85-176,769. BERREY, KEVIN J, NEW YORK, NY. FILED 11-15-2010.

## Screaming Panda

THE MARK CONSISTS OF STANDARD CHARACTERS WITHOUT CLAIM TO ANY PARTICULAR FONT, STYLE, SIZE, OR COLOR.

FOR ENTERTAINMENT MEDIA PRODUCTION SERVICES FOR MOTION PICTURES, TELEVISION AND INTERNET; ENTERTAINMENT SERVICES, NAMELY, A MULTIMEDIA PROGRAM SERIES FEATURING COMEDY, ACTION AND ADVENTURE DISTRIBUTED VIA VARIOUS PLATFORMS ACROSS MULTIPLE FORMS OF TRANSMISSION MEDIA; ENTERTAINMENT SERVICES, NAMELY, MULTIMEDIA PRODUCTION SERVICES; MULTIMEDIA ENTERTAINMENT SERVICES IN THE NATURE OF DEVELOPMENT, PRODUCTION AND POST-PRODUCTION SERVICES IN THE FIELDS OF VIDEO AND FILMS (U.S. CLS. 100, 101 AND 107).

FIRST USE 1-19-2009; IN COMMERCE 4-2-2009.

LEIGH CAROLINE CASE, EXAMINING ATTORNEY

SN 85-176,917. DESHA PRODUCTIONS, INC., DBA BETTY-CONFIDENTIAL, PALO ALTO, CA. FILED 11-15-2010.

## Alley to the Valley

THE MARK CONSISTS OF STANDARD CHARACTERS WITHOUT CLAIM TO ANY PARTICULAR FONT, STYLE, SIZE, OR COLOR.

FOR EDUCATIONAL SERVICES, NAMELY, CONDUCTING SEMINARS, CONFERENCES, CLASSES AND WORKSHOPS IN THE FIELD OF TOPICS OF INTEREST TO WOMEN (U.S. CLS. 100, 101 AND 107).

FIRST USE 8-1-2010; IN COMMERCE 8-1-2010.

SANJEEV VOHRA, EXAMINING ATTORNEY

SN 85-176,928. FITNESS ANYWHERE, INC., SAN FRANCISCO, CA. FILED 11-15-2010.

## TRXHALE

THE MARK CONSISTS OF STANDARD CHARACTERS WITHOUT CLAIM TO ANY PARTICULAR FONT, STYLE, SIZE, OR COLOR.

OWNER OF U.S. REG. NOS. 3,202,696 AND 3,384,871.

FOR PHYSICAL EDUCATION; PHYSICAL EDUCATION SERVICES; PHYSICAL FITNESS CONDITIONING CLASSES; PHYSICAL FITNESS CONSULTATION; PHYSICAL FITNESS INSTRUCTION; PHYSICAL FITNESS STUDIO SERVICES, NAMELY, PROVIDING GROUP EXERCISE INSTRUCTION, EQUIPMENT, AND FACILITIES; PHYSICAL FITNESS TRAINING SERVICES (U.S. CLS. 100, 101 AND 107).

KEVIN DINALLO, EXAMINING ATTORNEY

**CLASS 41—(Continued).**

SN 85-176,941. FITNESS ANYWHERE, INC., SAN FRANCISCO, CA. FILED 11-15-2010.

**TRXTREME**

THE MARK CONSISTS OF STANDARD CHARACTERS WITHOUT CLAIM TO ANY PARTICULAR FONT, STYLE, SIZE, OR COLOR.

OWNER OF U.S. REG. NOS. 3,202,696 AND 3,384,871.

FOR PHYSICAL EDUCATION; PHYSICAL EDUCATION SERVICES; PHYSICAL FITNESS CONDITIONING CLASSES; PHYSICAL FITNESS CONSULTATION; PHYSICAL FITNESS INSTRUCTION; PHYSICAL FITNESS STUDIO SERVICES, NAMELY, PROVIDING GROUP EXERCISE INSTRUCTION, EQUIPMENT, AND FACILITIES; PHYSICAL FITNESS TRAINING SERVICES (U.S. CLS. 100, 101 AND 107).

KEVIN DINALLO, EXAMINING ATTORNEY

---

SN 85-176,944. FITNESS ANYWHERE, INC., SAN FRANCISCO, CA. FILED 11-15-2010.

**TRXPRESS**

THE MARK CONSISTS OF STANDARD CHARACTERS WITHOUT CLAIM TO ANY PARTICULAR FONT, STYLE, SIZE, OR COLOR.

OWNER OF U.S. REG. NOS. 3,202,696 AND 3,384,871.

FOR PHYSICAL EDUCATION; PHYSICAL EDUCATION SERVICES; PHYSICAL FITNESS CONDITIONING CLASSES; PHYSICAL FITNESS CONSULTATION; PHYSICAL FITNESS INSTRUCTION; PHYSICAL FITNESS STUDIO SERVICES, NAMELY, PROVIDING GROUP EXERCISE INSTRUCTION, EQUIPMENT, AND FACILITIES; PHYSICAL FITNESS TRAINING SERVICES (U.S. CLS. 100, 101 AND 107).

KEVIN DINALLO, EXAMINING ATTORNEY

---

SN 85-176,945. FITNESS ANYWHERE, INC., SAN FRANCISCO, CA. FILED 11-15-2010.

**TRXPLODE**

THE MARK CONSISTS OF STANDARD CHARACTERS WITHOUT CLAIM TO ANY PARTICULAR FONT, STYLE, SIZE, OR COLOR.

OWNER OF U.S. REG. NOS. 3,202,696 AND 3,384,871.

FOR PHYSICAL EDUCATION; PHYSICAL EDUCATION SERVICES; PHYSICAL FITNESS CONDITIONING CLASSES; PHYSICAL FITNESS CONSULTATION; PHYSICAL FITNESS INSTRUCTION; PHYSICAL FITNESS STUDIO SERVICES, NAMELY, PROVIDING GROUP EXERCISE INSTRUCTION, EQUIPMENT, AND FACILITIES; PHYSICAL FITNESS TRAINING SERVICES (U.S. CLS. 100, 101 AND 107).

KEVIN DINALLO, EXAMINING ATTORNEY

**CLASS 41—(Continued).**

SN 85-176,953. DEYOUNG PARTNERSHIP, TINLEY PARK, IL. FILED 11-15-2010.

**QUASIMODO**

THE MARK CONSISTS OF STANDARD CHARACTERS WITHOUT CLAIM TO ANY PARTICULAR FONT, STYLE, SIZE, OR COLOR.

FOR DANCE EVENTS; ENTERTAINMENT AND EDUCATION SERVICES IN THE NATURE OF LIVE DANCE AND MUSICAL PERFORMANCES; ENTERTAINMENT IN THE NATURE OF DANCE PERFORMANCES; ENTERTAINMENT IN THE NATURE OF LIVE PERFORMANCES BY A THEATRE GROUP; ENTERTAINMENT IN THE NATURE OF ORCHESTRA PERFORMANCES; ENTERTAINMENT IN THE NATURE OF THEATER PRODUCTIONS; ENTERTAINMENT SERVICES IN THE NATURE OF LIVE MUSICAL PERFORMANCES; ENTERTAINMENT SERVICES IN THE NATURE OF PRESENTING LIVE MUSICAL PERFORMANCES; ENTERTAINMENT SERVICES, NAMELY, PROVIDING INFORMATION ABOUT A RECORDING ARTIST VIA AN ONLINE NETWORK; ENTERTAINMENT, NAMELY, LIVE MUSIC CONCERTS; ENTERTAINMENT, NAMELY, LIVE PERFORMANCES BY ROCK GROUPS; PLANNING ARRANGEMENT OF SHOWING MOVIES, SHOWS, PLAYS OR MUSICAL PERFORMANCES; PRESENTATION OF LIVE SHOW PERFORMANCES; PRODUCTION OF SOUND RECORDINGS; RECORDING STUDIO SERVICES; THEATRICAL AND MUSICAL FLOOR SHOWS PROVIDED AT PERFORMANCE VENUES (U.S. CLS. 100, 101 AND 107).

KATHERINE STOIDES, EXAMINING ATTORNEY

---

SN 85-177,292. PRAXIS AMERICA, INC., HONOLULU, HI. FILED 11-15-2010.

**READCH**

THE MARK CONSISTS OF STANDARD CHARACTERS WITHOUT CLAIM TO ANY PARTICULAR FONT, STYLE, SIZE, OR COLOR.

FOR EDUCATIONAL SERVICES, NAMELY, CONDUCTING CLASSES AND SEMINARS IN THE FIELDS OF A READ ALOUD/READ ALONG AND WRITING CURRICULUM AND DISTRIBUTION OF TRAINING MATERIALS IN CONNECTION THEREWITH; EDUCATIONAL SERVICES, NAMELY, DEVELOPING CURRICULUM FOR EDUCATORS (U.S. CLS. 100, 101 AND 107). FIRST USE 3-1-2010; IN COMMERCE 10-1-2010.

BRENDAN REGAN, EXAMINING ATTORNEY

**CLASS 41—(Continued).**

SN 85-177,370. SHUFFLE MASTER, INC., LAS VEGAS, NV.  
FILED 11-15-2010.



OWNER OF U.S. REG. NOS. 2,233,569, 2,397,403 AND 2,650,060.

NO CLAIM IS MADE TO THE EXCLUSIVE RIGHT TO USE "THREE CARD POKER", APART FROM THE MARK AS SHOWN.

THE MARK CONSISTS OF THE OUTLINE OF THREE PLAYING CARDS WITH A DIAMOND DESIGN ON THE FACE OF EACH CARD AND THE WORDS "THREE CARD POKER" UNDER THE PLAYING CARDS.

FOR ENTERTAINMENT SERVICES, NAMELY, PROVIDING A LIVE GAME OF CHANCE ON A GAMING TABLE THAT ENABLES CREDIT WAGERING (U.S. CLS. 100, 101 AND 107).

NAPOLEON SHARMA, EXAMINING ATTORNEY

**CLASS 41—(Continued).**

SN 85-177,680. HAZELBAKER, SHELDON, BELLE VERNON, PA. FILED 11-16-2010.

## Obscured By Pink

THE MARK CONSISTS OF STANDARD CHARACTERS WITHOUT CLAIM TO ANY PARTICULAR FONT, STYLE, SIZE, OR COLOR.

FOR ENTERTAINMENT, NAMELY, LIVE MUSIC CONCERTS; ENTERTAINMENT, NAMELY, LIVE PERFORMANCES BY A MUSICAL BAND (U.S. CLS. 100, 101 AND 107).

FIRST USE 9-1-2007; IN COMMERCE 4-1-2010.

ELLEN B. AWRICH, EXAMINING ATTORNEY

SN 85-177,771. EVENTFUL MANAGEMENT CONFERENCES AND EVENTS PTY LTD, SYDNEY, NSW, AUSTRALIA, FILED 11-16-2010.

SN 85-177,629. LATSHAW TRAINING GROUP, INC., VERO BEACH, FL. FILED 11-16-2010.

## THE EVENTFUL GROUP

### "Taking Training to New Heights"

THE MARK CONSISTS OF STANDARD CHARACTERS WITHOUT CLAIM TO ANY PARTICULAR FONT, STYLE, SIZE, OR COLOR.

FOR TRAINING SERVICES IN THE FIELD OF AVIATION, NAMELY, PILOT AND MAINTENANCE (U.S. CLS. 100, 101 AND 107).

FIRST USE 1-1-2010; IN COMMERCE 1-1-2010.

KATHY DE JONGE, EXAMINING ATTORNEY

THE MARK CONSISTS OF STANDARD CHARACTERS WITHOUT CLAIM TO ANY PARTICULAR FONT, STYLE, SIZE, OR COLOR.

NO CLAIM IS MADE TO THE EXCLUSIVE RIGHT TO USE "GROUP", APART FROM THE MARK AS SHOWN.

FOR PROVIDING CORPORATE TRAINING IN THE FIELDS OF ENTERPRISE TECHNOLOGY, NAMELY, ENTERPRISE APPLICATION SOFTWARE, AND ENTERPRISE ASSET MANAGEMENT; ARRANGING AND CONDUCTING OF CORPORATE CONFERENCES, WORKSHOPS AND SEMINARS IN THE FIELDS OF ENTERPRISE TECHNOLOGY, NAMELY, ENTERPRISE APPLICATION SOFTWARE, AND ENTERPRISE ASSET MANAGEMENT (U.S. CLS. 100, 101 AND 107).

JOHN HWANG, EXAMINING ATTORNEY

**CLASS 41—(Continued).**

SN 85-177,773. TRUSTEES OF BOSTON COLLEGE, THE, CHESTNUT HILL, MA. FILED 11-16-2010.

**ICE JAM**

THE MARK CONSISTS OF STANDARD CHARACTERS WITHOUT CLAIM TO ANY PARTICULAR FONT, STYLE, SIZE, OR COLOR.

FOR ARRANGING AND CONDUCTING ATHLETIC COMPETITIONS IN SPORTS FACILITIES AND ON COLLEGE AND UNIVERSITY CAMPUSES; ORGANIZATION OF SPORTS COMPETITIONS IN SPORTS FACILITIES AND ON COLLEGE AND UNIVERSITY CAMPUSES; ENTERTAINMENT IN THE NATURE OF COMPETITIONS IN THE FIELD OF ATHLETICS IN SPORTS FACILITIES AND ON COLLEGE AND UNIVERSITY CAMPUSES; CONDUCTING ENTERTAINMENT EXHIBITIONS IN THE NATURE OF LIVE MUSICAL AND VARIETY SHOW PERFORMANCES IN SPORTS FACILITIES AND ON COLLEGE AND UNIVERSITY CAMPUSES (U.S. CLS. 100, 101 AND 107).

FIRST USE 10-26-2010; IN COMMERCE 10-26-2010.  
TOBY BULLOFF, EXAMINING ATTORNEY

---

SN 85-177,800. BFF ENTERTAINMENT, INC., NEW YORK, NY. FILED 11-16-2010.

**THERE'S NO PLACE LIKE OM**

THE MARK CONSISTS OF STANDARD CHARACTERS WITHOUT CLAIM TO ANY PARTICULAR FONT, STYLE, SIZE, OR COLOR.

FOR ENTERTAINMENT SERVICES, NAMELY, A DOCUMENTARY STYLE ON GOING SERIES PROVIDED THROUGH TELEVISION AND WEBCASTS OR OVER ANY OTHER COMMUNICATION NETWORK RELATING TO MATTERS OF HEALTH, WELLNESS AND PERSONAL AND SPIRITUAL GROWTH (U.S. CLS. 100, 101 AND 107).

JOHN WILKE, EXAMINING ATTORNEY

**CLASS 41—(Continued).**

SN 85-177,818. BFF ENTERTAINMENT, INC., NEW YORK, NY. FILED 11-16-2010.

**FINDING OM**

THE MARK CONSISTS OF STANDARD CHARACTERS WITHOUT CLAIM TO ANY PARTICULAR FONT, STYLE, SIZE, OR COLOR.

FOR ENTERTAINMENT SERVICES, NAMELY, A DOCUMENTARY STYLE ON GOING SERIES PROVIDED THROUGH TELEVISION AND WEBCASTS OR OVER ANY OTHER COMMUNICATION NETWORK RELATING TO MATTERS OF HEALTH, WELLNESS AND PERSONAL AND SPIRITUAL GROWTH (U.S. CLS. 100, 101 AND 107).

JOHN WILKE, EXAMINING ATTORNEY

---

SN 85-177,884. HOBBY LOBBY STORES, INC., OKLAHOMA CITY, OK. FILED 11-16-2010.

**PASSAGES**

THE MARK CONSISTS OF STANDARD CHARACTERS WITHOUT CLAIM TO ANY PARTICULAR FONT, STYLE, SIZE, OR COLOR.

FOR CONDUCTING EDUCATIONAL EXHIBITIONS IN THE NATURE OF ANTIQUITIES AND HISTORICAL ARTIFACTS (U.S. CLS. 100, 101 AND 107).

DEIRDRE ROBERTSON, EXAMINING ATTORNEY

---

SN 85-177,931. THE CARTOON NETWORK, INC., ATLANTA, GA. FILED 11-16-2010.

**THE PROFESSOR BROTHERS**

THE MARK CONSISTS OF STANDARD CHARACTERS WITHOUT CLAIM TO ANY PARTICULAR FONT, STYLE, SIZE, OR COLOR.

FOR ENTERTAINMENT SERVICES, NAMELY, PROVISION OF ONGOING MULTIMEDIA PROGRAMS IN THE FIELD OF COMEDY, ACTION AND ADVENTURE DISTRIBUTED VIA VARIOUS PLATFORMS ACROSS MULTIPLE FORMS OF TRANSMISSION MEDIA (U.S. CLS. 100, 101 AND 107).

FRED CARL, EXAMINING ATTORNEY

**CLASS 41—(Continued).**

SN 85-178,068. STUART LEVINE & ASSOCIATES, LLC, JERICO, NY. FILED 11-16-2010.

**CUT TO THE CHASE**

THE MARK CONSISTS OF STANDARD CHARACTERS WITHOUT CLAIM TO ANY PARTICULAR FONT, STYLE, SIZE, OR COLOR.

OWNER OF U.S. REG. NOS. 3,313,533 AND 3,580,005. FOR ON-LINE ELECTRONIC NEWSLETTERS DELIVERED BY E-MAIL IN THE FIELD OF PROVIDING STRATEGIC INSIGHTS FOR BOARD MEMBERS (U.S. CLS. 100, 101 AND 107). FIRST USE 11-16-2010; IN COMMERCE 11-16-2010. YAT SYE, LEE, EXAMINING ATTORNEY

SN 85-178,134. GENEVACIRCLE CORPORATE SOLUTIONS LLC, ATLANTA, GA. FILED 11-16-2010.

**GenevaCircle**

THE MARK CONSISTS OF STANDARD CHARACTERS WITHOUT CLAIM TO ANY PARTICULAR FONT, STYLE, SIZE, OR COLOR.

FOR PROVIDING NEWSLETTERS IN THE FIELD OF EMPLOYMENT HIRING, RECRUITING, PLACEMENT, STAFFING AND CAREER NETWORKING SERVICES VIA E-MAIL (U.S. CLS. 100, 101 AND 107). FIRST USE 6-13-2008; IN COMMERCE 10-4-2010. JANICE KIM, EXAMINING ATTORNEY

SN 85-178,270. MORELLI, HEATHER, NEW YORK CITY, NY. FILED 11-16-2010.

**The Dirty Thirty**

THE MARK CONSISTS OF STANDARD CHARACTERS WITHOUT CLAIM TO ANY PARTICULAR FONT, STYLE, SIZE, OR COLOR.

FOR ENTERTAINMENT SERVICES IN THE NATURE OF AN ON-GOING REALITY BASED TELEVISION PROGRAM (U.S. CLS. 100, 101 AND 107). TINA MAI, EXAMINING ATTORNEY

**CLASS 41—(Continued).**

SN 85-178,375. REALNETWORKS, INC., SEATTLE, WA. FILED 11-16-2010.

**SECRET PLANT SOCIETY**

THE MARK CONSISTS OF STANDARD CHARACTERS WITHOUT CLAIM TO ANY PARTICULAR FONT, STYLE, SIZE, OR COLOR.

FOR ENTERTAINMENT SERVICES, NAMELY, PROVIDING TEMPORARY USE OF NON-DOWNLOADABLE ELECTRONIC GAMES (U.S. CLS. 100, 101 AND 107). FIRST USE 10-22-2010; IN COMMERCE 10-22-2010. MICHELE SWAIN, EXAMINING ATTORNEY

SN 85-178,414. LIL VELVET EARS, INC., SAN PEDRO, CA. FILED 11-16-2010.

**VELVET EARS**

THE MARK CONSISTS OF STANDARD CHARACTERS WITHOUT CLAIM TO ANY PARTICULAR FONT, STYLE, SIZE, OR COLOR.

FOR ENTERTAINMENT SERVICES, NAMELY, PROVIDING ADVICE AND INFORMATION FOR MUSIC IN TELEVISION, VIDEO AND FILM, AND CONCEPT AND SCRIPT DEVELOPMENT; MUSIC SELECTION SERVICES FOR USE IN TELEVISION, FILM, RADIO AND VIDEO GAMES; MUSIC PRODUCTION SERVICES (U.S. CLS. 100, 101 AND 107). LAKEISHA LEWIS, EXAMINING ATTORNEY

SN 85-178,663. OLIVARES, PABLO VALOY, BUENOS AIRES, ARGENTINA, FILED 11-17-2010.

**RESTINBONES**

THE MARK CONSISTS OF STANDARD CHARACTERS WITHOUT CLAIM TO ANY PARTICULAR FONT, STYLE, SIZE, OR COLOR.

FOR ENTERTAINMENT IN THE NATURE OF A MUSICAL GROUP (U.S. CLS. 100, 101 AND 107). KAREN SEVERSON, EXAMINING ATTORNEY

**CLASS 41—(Continued).**

SN 85-178,806. RATLIFF ENTERTAINMENT LLC, WEST HOLLYWOOD, CA. FILED 11-17-2010.

**THE SEVEN SEES**

THE MARK CONSISTS OF STANDARD CHARACTERS WITHOUT CLAIM TO ANY PARTICULAR FONT, STYLE, SIZE, OR COLOR.

FOR PROVIDING INFORMATION, NEWS AND COMMENTARY IN THE FIELD OF CURRENT EVENTS RELATING TO MOVIES, TELEVISION, MUSIC AND SPORTS (U.S. CLS. 100, 101 AND 107).

FIRST USE 7-23-2010; IN COMMERCE 7-23-2010.  
CAROLYN CATALDO, EXAMINING ATTORNEY

SN 85-178,913. SAAVEDRA, NELSON, MORGANVILLE, NJ. FILED 11-17-2010.

**Wise Times**

THE MARK CONSISTS OF STANDARD CHARACTERS WITHOUT CLAIM TO ANY PARTICULAR FONT, STYLE, SIZE, OR COLOR.

FOR PUBLICATION OF ELECTRONIC NEWSPAPERS ACCESSIBLE VIA A GLOBAL COMPUTER NETWORK (U.S. CLS. 100, 101 AND 107).

FIRST USE 3-15-1980; IN COMMERCE 3-15-1980.  
TRACY WHITTAKER-BROWN, EXAMINING ATTORNEY

SN 85-178,970. MASTERING BUSINESS DEVELOPMENT INC., CHARLOTTE, NC. FILED 11-17-2010.

**HUMINT**

THE MARK CONSISTS OF STANDARD CHARACTERS WITHOUT CLAIM TO ANY PARTICULAR FONT, STYLE, SIZE, OR COLOR.

FOR EDUCATIONAL SERVICES, NAMELY, DEVELOPING AND CONDUCTING TRAINING COURSES AND DISTRIBUTION OF TRAINING MATERIALS IN CONNECTION THEREWITH FOR SUBJECT MATTERS AS REQUESTED BY CUSTOMERS (U.S. CLS. 100, 101 AND 107).

SANJEEV VOHRA, EXAMINING ATTORNEY

**CLASS 41—(Continued).**

SN 85-178,978. LINDSAY, TANIRA C., ROSEDALE, NY. FILED 11-17-2010.

**CAT WALK DIVA**

THE MARK CONSISTS OF STANDARD CHARACTERS WITHOUT CLAIM TO ANY PARTICULAR FONT, STYLE, SIZE, OR COLOR.

FOR ENTERTAINMENT IN THE NATURE OF LIVE PERFORMANCES BY A SINGER/MODEL (U.S. CLS. 100, 101 AND 107).

FIRST USE 10-30-2009; IN COMMERCE 10-30-2009.  
MARK SPARACINO, EXAMINING ATTORNEY

SN 85-178,993. MANNING, MICHELLE L., ALBUQUERQUE, NM. FILED 11-17-2010.

**Crazy and Functional**

THE MARK CONSISTS OF STANDARD CHARACTERS WITHOUT CLAIM TO ANY PARTICULAR FONT, STYLE, SIZE, OR COLOR.

FOR LIFE COACHING SERVICES IN THE FIELD OF LIFE ENRICHMENT/EMOTIONAL FULFILLMENT; PEER TO PEER COACHING SERVICES IN THE FIELD OF PSYCHOTHERAPY/EMOTIONAL FULFILLMENT; PERSONAL COACHING SERVICES IN THE FIELD OF LIFE ENRICHMENT/EMOTIONAL FULFILLMENT; PROFESSIONAL COACHING SERVICES IN THE FIELD OF PSYCHOTHERAPY/EMOTIONAL FULFILLMENT; PROVIDING GROUP COACHING IN THE FIELD OF PSYCHOTHERAPY/EMOTIONAL FULFILLMENT (U.S. CLS. 100, 101 AND 107).

MARK SPARACINO, EXAMINING ATTORNEY

SN 85-179,025. NUESTROS PEQUEÑOS HERMANOS INTERNATIONAL, WASHINGTON, DC. FILED 11-17-2010.

**NPH**

THE MARK CONSISTS OF STANDARD CHARACTERS WITHOUT CLAIM TO ANY PARTICULAR FONT, STYLE, SIZE, OR COLOR.

OWNER OF U.S. REG. NOS. 3,657,388, 3,657,390 AND OTHERS.

FOR PROVIDING EDUCATION IN THE NATURE OF CLASSES IN THE FIELD OF CHRISTIAN INSTRUCTION TO ORPHANED AND ABANDONED CHILDREN (U.S. CLS. 100, 101 AND 107).

FIRST USE 1-1-1955; IN COMMERCE 1-1-1955.  
MARGARET POWER, EXAMINING ATTORNEY



**CLASS 41—(Continued).**

SN 85-179,058. ALCHEMICAL COURTYARD, LLC, MIAMI, FL. FILED 11-17-2010.



THE MARK CONSISTS OF A VERTICAL LINE WITH THE WORD "THE" ABOVE THE WORD "ALCHEMICAL" ABOVE THE WORD "COURTYARD" IN A STACKED FORMATION, APPEARING BELOW A GEOMETRIC THAT COMPRISES A COMBINATION OF SUBSTANTIALLY CONCENTRIC CIRCLES, SPIRALS, STARBURSTS AND LEAF-LIKE SHAPES.

FOR EDUCATION SERVICES, NAMELY, PROVIDING CLASSES, SEMINARS, AND WORKSHOPS IN THE FIELDS OF HEALTHCARE, NUTRITION, EDUCATION, PEDAGOGY, THE ARTS, AGRICULTURE, THE ENVIRONMENT, RELIGION, SCIENCE AND SPIRITUALITY (U.S. CLS. 100, 101 AND 107).

FIRST USE 6-20-2005; IN COMMERCE 6-20-2005.  
JAMES STEIN, EXAMINING ATTORNEY

SN 85-179,087. FIT KIDS AMERICA, INC., CARLSBAD, CA. FILED 11-17-2010.

## Fit Kids America

THE MARK CONSISTS OF STANDARD CHARACTERS WITHOUT CLAIM TO ANY PARTICULAR FONT, STYLE, SIZE, OR COLOR.

SEC. 2(F).  
FOR AMATEUR YOUTH SPORTS SERVICES, NAMELY, ORGANIZING AND PROVIDING YOUTH SPORTS ACTIVITIES (U.S. CLS. 100, 101 AND 107).

FIRST USE 1-15-2005; IN COMMERCE 1-15-2005.  
JAMES STEIN, EXAMINING ATTORNEY

**CLASS 41—(Continued).**

SN 85-179,163. LOREN STAPLIN, QUAKERTOWN, PA. FILED 11-17-2010.

## DRIVINGHEALTH

THE MARK CONSISTS OF STANDARD CHARACTERS WITHOUT CLAIM TO ANY PARTICULAR FONT, STYLE, SIZE, OR COLOR.

FOR PROVIDING COURSES OF INSTRUCTION TO TRAIN THE ELDERLY ON SAFE DRIVING PRACTICES AND PROVIDING SKILLS ASSESSMENTS IN CONNECTION THEREWITH (U.S. CLS. 100, 101 AND 107).

FIRST USE 3-1-2003; IN COMMERCE 3-1-2003.  
SANI KHOURI, EXAMINING ATTORNEY

SN 85-179,244. KENTUCKY COUNTRY DAY SCHOOL, INC., LOUISVILLE, KY. FILED 11-17-2010.

## KCD

THE MARK CONSISTS OF STANDARD CHARACTERS WITHOUT CLAIM TO ANY PARTICULAR FONT, STYLE, SIZE, OR COLOR.

FOR EDUCATING AT SENIOR HIGH SCHOOLS; EDUCATION SERVICES IN THE NATURE OF EARLY CHILDHOOD INSTRUCTION; EDUCATION SERVICES, NAMELY, PROVIDING KINDERGARTEN THROUGH 12TH GRADE (K-12) CLASSROOM INSTRUCTION; EDUCATIONAL COUNSELING SERVICES TO ASSIST STUDENTS IN PLANNING AND PREPARING FOR FURTHER EDUCATION; EDUCATIONAL PROGRAMS, NAMELY, PRE-SCHOOLS; EDUCATIONAL SERVICES, NAMELY, PROVIDING COURSES OF INSTRUCTION AT THE PRE-KINDERGARTEN THROUGH 12TH GRADE LEVEL (U.S. CLS. 100, 101 AND 107).

FIRST USE 0-0-1972; IN COMMERCE 0-0-1972.  
BRENDAN REGAN, EXAMINING ATTORNEY

**CLASS 41—(Continued).**

SN 85-179,249. KENTUCKY COUNTRY DAY SCHOOL, INC., LOUISVILLE, KY. FILED 11-17-2010.

**KENTUCKY COUNTRY DAY**

THE MARK CONSISTS OF STANDARD CHARACTERS WITHOUT CLAIM TO ANY PARTICULAR FONT, STYLE, SIZE, OR COLOR.

NO CLAIM IS MADE TO THE EXCLUSIVE RIGHT TO USE "COUNTRY DAY", APART FROM THE MARK AS SHOWN.

SEC. 2(F).

FOR EDUCATING AT SENIOR HIGH SCHOOLS; EDUCATION SERVICES IN THE NATURE OF EARLY CHILDHOOD INSTRUCTION; EDUCATION SERVICES, NAMELY, PROVIDING KINDERGARTEN THROUGH 12TH GRADE (K-12) CLASSROOM INSTRUCTION; EDUCATIONAL COUNSELING SERVICES TO ASSIST STUDENTS IN PLANNING AND PREPARING FOR FURTHER EDUCATION; EDUCATIONAL PROGRAMS, NAMELY, PRE-SCHOOLS; EDUCATIONAL SERVICES, NAMELY, PROVIDING COURSES OF INSTRUCTION AT THE PRE-KINDERGARTEN THROUGH 12TH GRADE LEVEL (U.S. CLS. 100, 101 AND 107).

FIRST USE 0-0-1972; IN COMMERCE 0-0-1972.  
BRENDAN REGAN, EXAMINING ATTORNEY

SN 85-179,254. CENTER FOR COURAGE AND RENEWAL, BAINBRIDGE ISLAND, WA. FILED 11-17-2010.

**CIRCLE OF TRUST**

THE MARK CONSISTS OF STANDARD CHARACTERS WITHOUT CLAIM TO ANY PARTICULAR FONT, STYLE, SIZE, OR COLOR.

OWNER OF U.S. REG. NO. 3,041,223.

FOR CONDUCTING WORKSHOPS AND SEMINARS IN PERSONAL AND PROFESSIONAL DEVELOPMENT; EDUCATION SERVICES, NAMELY, PROVIDING CLASSES, SEMINARS, WORKSHOPS AND RETREATS IN THE FIELDS OF PERSONAL AND PROFESSIONAL DEVELOPMENT; EDUCATIONAL SERVICES, NAMELY, CONDUCTING CLASSES, SEMINARS, WORKSHOPS AND RETREATS IN THE FIELDS OF PERSONAL AND PROFESSIONAL DEVELOPMENT AND DISTRIBUTION OF TRAINING MATERIALS IN CONNECTION THEREWITH (U.S. CLS. 100, 101 AND 107).

FIRST USE 1-30-2005; IN COMMERCE 1-30-2005.  
BRENDAN REGAN, EXAMINING ATTORNEY

**CLASS 41—(Continued).**

SN 85-179,366. KRISTIE LOU HILLENBURG, LITTLE RIVER, SC. AND LINDA WRIGHT GOODMAN, RICHMOND, VA. FILED 11-17-2010.

**Here Women Tell**

THE MARK CONSISTS OF STANDARD CHARACTERS WITHOUT CLAIM TO ANY PARTICULAR FONT, STYLE, SIZE, OR COLOR.

FOR AUDIO PRODUCTION SERVICES, NAMELY, CREATING AND PRODUCING AMBIENT SOUNDS-CAPES, AND SOUND STORIES FOR MUSEUMS, GALLERIES, ATTRACTIONS, PODCASTS, BROADCASTS, WEBSITES AND GAMES; PROVIDING ONLINE INTERVIEWS FEATURING STORYTELLERS IN THE FIELD OF STORYTELLING FOR ENTERTAINMENT PURPOSES (U.S. CLS. 100, 101 AND 107).

DOMINIC J. FERRAIUOLO, EXAMINING ATTORNEY

SN 85-179,598. MARUHAN CORPORATION, KAMIGYO-KU KYOTO, JAPAN, FILED 11-18-2010.



THE COLOR(S) RED AND BLACK IS/ARE CLAIMED AS A FEATURE OF THE MARK.

THE MARK CONSISTS OF THE WORDING "MARUHAN" IN BLACK WITH A STYLIZED "M" AND SHADED CIRCLE IN RED ABOVE IT.

FOR PROVIDING AMUSEMENT FACILITIES; PROVIDING CASINO FACILITIES; PROVIDING GOLF FACILITIES; AMUSEMENT ARCADES; PROVIDING KARA-OKE FACILITIES; PROVIDING BOWLING ALLEYS; PROVIDING PACHINKO PARLORS; PROVIDING SLOT MACHINE PARLORS; CONDUCTING AND PROVIDING FACILITIES FOR SPECIAL EVENTS FEATURING CASINO AND GAMING CONTESTS AND TOURNAMENTS; PROVIDING FACILITIES FOR PARLOR GAME TOURNAMENTS (U.S. CLS. 100, 101 AND 107).

VIVIAN MICZNIK FIRST, EXAMINING ATTORNEY

**CLASS 41—(Continued).**

SN 85-179,632. FUNEDUCATION.COM, INC., DBA FUNE-  
DUCATION, INC., SAN DIEGO, CA. FILED 11-18-2010.

**ISIQ**

THE MARK CONSISTS OF STANDARD CHARACTERS  
WITHOUT CLAIM TO ANY PARTICULAR FONT, STYLE,  
SIZE, OR COLOR.

FOR PREPARING, ADMINISTERING, AND SCORING  
STANDARDIZED TESTS (U.S. CLS. 100, 101 AND 107).  
FIRST USE 7-31-2009; IN COMMERCE 7-31-2009.  
ELIZABETH KAJUBI, EXAMINING ATTORNEY

SN 85-179,739. SHUTTERBOX ENTERTAINMENT LLC, OR-  
LAND PARK, IL. FILED 11-18-2010.

**EVENT HEROES.**

THE MARK CONSISTS OF STANDARD CHARACTERS  
WITHOUT CLAIM TO ANY PARTICULAR FONT, STYLE,  
SIZE, OR COLOR.

NO CLAIM IS MADE TO THE EXCLUSIVE RIGHT TO  
USE "EVENT", APART FROM THE MARK AS SHOWN.

FOR DIGITAL IMAGING SERVICES; PHOTOGRAPHY  
SERVICES; RENTAL OF PORTABLE PHOTOGRAPHY  
AND/OR VIDEOGRAPHY BOOTHS FOR TAKING OF  
PICTURES AND VIDEOS (U.S. CLS. 100, 101 AND 107).  
FIRST USE 4-1-2010; IN COMMERCE 4-1-2010.  
DORITT L. CARROLL, EXAMINING ATTORNEY

SN 85-179,860. INDAPTIVE TECHNOLOGIES, INC., HOUS-  
TON, TX. FILED 11-18-2010.

**PETROPEA**

THE MARK CONSISTS OF STANDARD CHARACTERS  
WITHOUT CLAIM TO ANY PARTICULAR FONT, STYLE,  
SIZE, OR COLOR.

FOR PROVIDING AN ON-LINE NON-DOWNLOAD-  
ABLE ELECTRONIC PUBLICATION IN THE NATURE  
OF AN INTERACTIVE GLOSSARY AND ENCYCLOPE-  
DIA IN THE OIL AND GAS FIELD (U.S. CLS. 100, 101  
AND 107).  
WILLIAM P. SHANAHAN, EXAMINING ATTORNEY

**CLASS 41—(Continued).**

SN 85-180,003. THE SHADE STORE LLC, PORT CHESTER,  
NY. FILED 11-18-2010.

**PRETTY SIMPLE**

THE MARK CONSISTS OF STANDARD CHARACTERS  
WITHOUT CLAIM TO ANY PARTICULAR FONT, STYLE,  
SIZE, OR COLOR.

FOR ON-LINE JOURNALS, NAMELY, BLOGS FEAT-  
URING HOME DECORATION, WINDOW TREAT-  
MENTS, CURTAINS, RESIDENTIAL STYLE  
COMMENT, CRITICISM AND ADVICE (U.S. CLS. 100,  
101 AND 107).

FIRST USE 11-1-2010; IN COMMERCE 11-1-2010.  
MAYUR VAGHANI, EXAMINING ATTORNEY

SN 85-180,075. GANZ, WOODBRIDGE, ONT, CANADA,  
FILED 11-18-2010.

**MAZIN'**

THE MARK CONSISTS OF STANDARD CHARACTERS  
WITHOUT CLAIM TO ANY PARTICULAR FONT, STYLE,  
SIZE, OR COLOR.

FOR ENTERTAINMENT SERVICES, NAMELY, PRO-  
VISION OF ENTERTAINMENT FOR CHILDREN BY  
MEANS OF A WEBSITE FEATURING ONLINE GAMES,  
AND WIRELESS COMPUTER GAMES AND MOBILE  
DEVICE INTERACTIVE GAMES AND ACTIVITIES IN  
SINGLE AND MULTI-USER FORMATS USING ONLINE  
AVATARS PLAYED OVER COMPUTER NETWORKS  
AND GLOBAL COMMUNICATION NETWORKS AND  
PROVIDED FROM A GLOBAL COMPUTER NETWORK  
AND PRODUCTION OF ANIMATED MOTION PIC-  
TURES ON THE INTERNET (U.S. CLS. 100, 101 AND  
107).

FIRST USE 7-1-2010; IN COMMERCE 7-1-2010.  
JENNY PARK, EXAMINING ATTORNEY

SN 85-180,088. THE SHADE STORE LLC, PORT CHESTER,  
NY. FILED 11-18-2010.

**BEHIND THE CURTAIN**

THE MARK CONSISTS OF STANDARD CHARACTERS  
WITHOUT CLAIM TO ANY PARTICULAR FONT, STYLE,  
SIZE, OR COLOR.

FOR ON-LINE JOURNALS, NAMELY, BLOGS FEAT-  
URING HOME DECORATION, WINDOW TREAT-  
MENTS, CURTAINS, RESIDENTIAL STYLE  
COMMENT, CRITICISM AND ADVICE (U.S. CLS. 100,  
101 AND 107).  
MAYUR VAGHANI, EXAMINING ATTORNEY

**CLASS 41—(Continued).**

SN 85-180,532. ARTIX ENTERTAINMENT, LLC, LAND O' LAKES, FL. FILED 11-18-2010.

# HeroSmash

THE MARK CONSISTS OF STANDARD CHARACTERS WITHOUT CLAIM TO ANY PARTICULAR FONT, STYLE, SIZE, OR COLOR.

FOR ENTERTAINMENT SERVICES, NAMELY, PROVIDING ONLINE, REAL-TIME COMPUTER GAMES FOR OTHERS OVER GLOBAL AND LOCAL AREA COMPUTER NETWORKS (U.S. CLS. 100, 101 AND 107).  
LINDA E. BLOHM, EXAMINING ATTORNEY

---

SN 85-180,997. HANG TEN INTERACTIVE, INC., EVERETT, WA. FILED 11-19-2010.

# GAMERFUSE

THE MARK CONSISTS OF STANDARD CHARACTERS WITHOUT CLAIM TO ANY PARTICULAR FONT, STYLE, SIZE, OR COLOR.

FOR PROVIDING ON-LINE INFORMATION IN THE FIELD OF VIDEO GAMES AND COMPUTER GAMES VIA THE INTERNET; PROVIDING AN ON-LINE COMPUTER DATABASE IN THE FIELD OF VIDEO AND COMPUTER GAMES; ENTERTAINMENT SERVICES IN THE NATURE OF ON-LINE NON-DOWNLOADABLE VIDEOS AND PHOTOGRAPHS IN THE FIELD OF COMPUTER GAMES AND VIDEO GAMES; ENTERTAINMENT SERVICES IN THE FIELD OF PROVIDING ON-LINE REVIEWS OF COMPUTER AND VIDEO GAMES; PROVIDING A WEBSITE FEATURING ON-LINE NON-DOWNLOADABLE VIDEO PROGRAMS VIA THE INTERNET IN THE FIELD OF COMPUTER GAMES, VIDEO GAMES AND ENTERTAINMENT NEWS; ENTERTAINMENT SERVICES, NAMELY, PROVIDING ON-LINE COMPUTER GAMES; ON-LINE JOURNALS, NAMELY, BLOGS FEATURING PERSONAL OPINIONS IN THE FIELD OF GENERAL INTEREST, COMPUTER GAMES AND VIDEO GAMES, AND ENTERTAINMENT (U.S. CLS. 100, 101 AND 107).

FIRST USE 12-1-2009; IN COMMERCE 12-1-2009.  
ALICIA COLLINS, EXAMINING ATTORNEY

**CLASS 41—(Continued).**

SN 85-181,077. HANG TEN INTERACTIVE, INC., EVERETT, WA. FILED 11-19-2010.



THE MARK CONSISTS OF A HONEYCOMB DESIGN FORMED BY THREE CONNECTED HEXAGONS SET TO THE LEFT OF THE STYLIZED WORD "GAMERFUSE" WHICH HAS AN ANGLED QUADRILATERAL IN THE CENTER OF THE "A".

FOR PROVIDING ON-LINE INFORMATION IN THE FIELD OF VIDEO GAMES AND COMPUTER GAMES VIA THE INTERNET; PROVIDING AN ON-LINE COMPUTER DATABASE IN THE FIELD OF VIDEO AND COMPUTER GAMES; ENTERTAINMENT SERVICES IN THE NATURE OF ON-LINE NON-DOWNLOADABLE VIDEOS AND PHOTOGRAPHS IN THE FIELD OF COMPUTER GAMES AND VIDEO GAMES; ENTERTAINMENT SERVICES IN THE FIELD OF PROVIDING ON-LINE REVIEWS OF COMPUTER AND VIDEO GAMES; PROVIDING A WEBSITE FEATURING ON-LINE NON-DOWNLOADABLE VIDEO PROGRAMS VIA THE INTERNET IN THE FIELD OF COMPUTER GAMES, VIDEO GAMES AND ENTERTAINMENT NEWS; ENTERTAINMENT SERVICES, NAMELY, PROVIDING ON-LINE COMPUTER GAMES; ON-LINE JOURNALS, NAMELY, BLOGS FEATURING PERSONAL OPINIONS IN THE FIELD OF GENERAL INTEREST, COMPUTER GAMES AND VIDEO GAMES, AND ENTERTAINMENT (U.S. CLS. 100, 101 AND 107).

FIRST USE 12-1-2009; IN COMMERCE 12-1-2009.  
ALICIA COLLINS, EXAMINING ATTORNEY

---

SN 85-181,198. MEDTRONIC, INC., MINNEAPOLIS, MN. FILED 11-19-2010.

# GIRLS' TIME OUT

THE MARK CONSISTS OF STANDARD CHARACTERS WITHOUT CLAIM TO ANY PARTICULAR FONT, STYLE, SIZE, OR COLOR.

FOR ORGANIZING AND SPONSORING EDUCATION EVENTS PROVIDING MEDICAL INFORMATION RELATING TO BLADDER CONTROL TREATMENT OPTIONS (U.S. CLS. 100, 101 AND 107).

FIRST USE 11-1-2010; IN COMMERCE 11-1-2010.  
HEATHER BIDDULPH, EXAMINING ATTORNEY

**CLASS 41—(Continued).**

SN 85-181,270. NEON TREES, INC., CEDAR HILLS, UT. FILED 11-19-2010.

**NEON TREES**

THE MARK CONSISTS OF STANDARD CHARACTERS WITHOUT CLAIM TO ANY PARTICULAR FONT, STYLE, SIZE, OR COLOR.

FOR ENTERTAINMENT SERVICES, NAMELY, LIVE PERFORMANCES BY A MUSICAL GROUP; ENTERTAINMENT SERVICES, NAMELY, LIVE, TELEVISED AND RADIO APPEARANCES BY A MUSICAL GROUP (U.S. CLS. 100, 101 AND 107).

FIRST USE 0-0-2005; IN COMMERCE 0-0-2005.  
STEVEN JACKSON, EXAMINING ATTORNEY

SN 85-181,928. BUSINESS WOMEN RISING, INC., NEWPORT BEACH, CA. FILED 11-21-2010.

**Business World Rising**

THE MARK CONSISTS OF STANDARD CHARACTERS WITHOUT CLAIM TO ANY PARTICULAR FONT, STYLE, SIZE, OR COLOR.

NO CLAIM IS MADE TO THE EXCLUSIVE RIGHT TO USE "BUSINESS WORLD", APART FROM THE MARK AS SHOWN.

FOR BUSINESS EDUCATION AND TRAINING SERVICES, NAMELY, DEVELOPING, AND FACILITATING CUSTOMIZED IN-COMPANY LEADERSHIP AND EXECUTIVE DEVELOPMENT PROGRAMS, PROVIDING EXECUTIVE COACHING SERVICES, AND PROVIDING PUBLIC AND IN-COMPANY KEYNOTE PRESENTATIONS TO BUSINESS LEADERS; EDUCATION SERVICES, NAMELY, PROVIDING MENTORING, TUTORING, CLASSES, SEMINARS AND WORKSHOPS IN THE FIELD OF MANAGEMENT, LEADERSHIP AND EXECUTIVE DEVELOPMENT; PEER TO PEER COACHING SERVICES IN THE FIELD OF MANAGEMENT, LEADERSHIP AND EXECUTIVE DEVELOPMENT; PROVIDING EDUCATIONAL MENTORING SERVICES AND PROGRAMS IN THE FIELD OF MANAGEMENT, LEADERSHIP AND EXECUTIVE DEVELOPMENT; PROVIDING GROUP COACHING AND LEARNING FORUMS IN THE FIELD OF LEADERSHIP DEVELOPMENT (U.S. CLS. 100, 101 AND 107).

HOWARD SMIGA, EXAMINING ATTORNEY

**CLASS 41—(Continued).**

SN 85-183,121. PELOZA JR., DANIEL, ELMHURST, IL. AND REA, D'ARCY, ELMHURST, IL. FILED 11-23-2010.

**FOOD MONGREL**

THE MARK CONSISTS OF STANDARD CHARACTERS WITHOUT CLAIM TO ANY PARTICULAR FONT, STYLE, SIZE, OR COLOR.

NO CLAIM IS MADE TO THE EXCLUSIVE RIGHT TO USE "FOOD", APART FROM THE MARK AS SHOWN.

FOR EDUCATIONAL SERVICES, NAMELY, PROVIDING A WEBSITE AND ONLINE JOURNAL, NAMELY, BLOG, FEATURING INFORMATION ON FOOD, FOOD SUSTAINABILITY AND NUTRITION (U.S. CLS. 100, 101 AND 107).

FIRST USE 11-7-2010; IN COMMERCE 11-7-2010.  
KEVON CHISOLM, EXAMINING ATTORNEY

SN 85-183,932. TWENTIETH CENTURY FOX FILM CORPORATION, LOS ANGELES, CA. FILED 11-23-2010.

**WHEELS UP**

THE MARK CONSISTS OF STANDARD CHARACTERS WITHOUT CLAIM TO ANY PARTICULAR FONT, STYLE, SIZE, OR COLOR.

FOR PROVIDING ON-LINE INFORMATION IN THE FIELD OF CURRENT EVENT NEWS, AUTOMOBILES AND ENTERTAINMENT VIA THE INTERNET; ENTERTAINMENT SERVICES IN THE NATURE OF PROGRAMS FEATURING CURRENT EVENT NEWS, AUTOMOBILES AND ENTERTAINMENT TRANSMITTED VIA THE INTERNET (U.S. CLS. 100, 101 AND 107).

FIRST USE 1-0-2010; IN COMMERCE 1-0-2010.  
ALICIA COLLINS, EXAMINING ATTORNEY

SN 85-187,028. HUMAN RESOURCES ASSOCIATION OF NEW YORK, TRENTON, NJ. FILED 11-30-2010.

**GEN XTRAORDINARY**

THE MARK CONSISTS OF STANDARD CHARACTERS WITHOUT CLAIM TO ANY PARTICULAR FONT, STYLE, SIZE, OR COLOR.

FOR EDUCATION SERVICES, NAMELY, MENTORING IN THE FIELD OF HUMAN RESOURCES; EDUCATIONAL SERVICES, NAMELY, CONDUCTING MEETINGS, TRAINING PROGRAMS, SEMINARS AND WORKSHOPS IN THE FIELD OF HUMAN RESOURCES; WORKSHOPS AND SEMINARS IN THE FIELD OF HUMAN RESOURCES (U.S. CLS. 100, 101 AND 107).

COLLEEN KEARNEY, EXAMINING ATTORNEY

**CLASS 41—(Continued).**

SN 85-187,031. JAMES P. OWEN, AUSTIN, TX. FILED 11-30-2010.

EVERYONE NEEDS A CODE... A  
CREED TO LIVE BY

THE MARK CONSISTS OF STANDARD CHARACTERS WITHOUT CLAIM TO ANY PARTICULAR FONT, STYLE, SIZE, OR COLOR.

FOR EDUCATIONAL AND ENTERTAINMENT SERVICES, NAMELY, PROVIDING MOTIVATIONAL SPEAKING SERVICES AND CLASSES, SEMINARS, WORKSHOPS AND PROGRAMS IN THE FIELDS OF LEADERSHIP, ETHICS, MOTIVATION, INSPIRATION, PERSEVERANCE, VALUES, AND PERSONAL GROWTH AND DEVELOPMENT (U.S. CLS. 100, 101 AND 107).

GISELLE AGOSTO, EXAMINING ATTORNEY

SN 85-189,648. ARTIX ENTERTAINMENT, LLC, LAND O' LAKES, FL. FILED 12-2-2010.



THE MARK CONSISTS OF THE WORD "HERO" ON TOP OF THE WORD PLUS EXCLAMATION "SMASH!," EACH OVER AND PARTIALLY OBSCURING A STYLIZED BLAST DESIGN.

FOR ENTERTAINMENT SERVICES, NAMELY, PROVIDING ONLINE, REAL-TIME COMPUTER GAMES FOR OTHERS OVER GLOBAL AND LOCAL AREA COMPUTER NETWORKS (U.S. CLS. 100, 101 AND 107).

LINDA E. BLOHM, EXAMINING ATTORNEY

SN 85-193,175. THE CARTOON NETWORK, INC., ATLANTA, GA. FILED 12-8-2010.

CHEYENNE CINNAMON AND THE  
FANTABULOUS UNICORN OF  
SUGAR TOWN CANDY FUDGE

THE MARK CONSISTS OF STANDARD CHARACTERS WITHOUT CLAIM TO ANY PARTICULAR FONT, STYLE, SIZE, OR COLOR.

FOR ENTERTAINMENT SERVICES, NAMELY, PROVISION OF ONGOING MULTIMEDIA PROGRAMS IN THE FIELD OF COMEDY, ACTION AND ADVENTURE DISTRIBUTED VIA VARIOUS PLATFORMS ACROSS MULTIPLE FORMS OF TRANSMISSION MEDIA (U.S. CLS. 100, 101 AND 107).

FRED CARL, EXAMINING ATTORNEY

**CLASS 41—(Continued).**

SN 85-193,182. THE CARTOON NETWORK, INC., ATLANTA, GA. FILED 12-8-2010.

NTSF: SD: SUV::

THE MARK CONSISTS OF STANDARD CHARACTERS WITHOUT CLAIM TO ANY PARTICULAR FONT, STYLE, SIZE, OR COLOR.

FOR ENTERTAINMENT SERVICES, NAMELY, PROVISION OF ONGOING MULTIMEDIA PROGRAMS IN THE FIELD OF COMEDY, ACTION AND ADVENTURE DISTRIBUTED VIA VARIOUS PLATFORMS ACROSS MULTIPLE FORMS OF TRANSMISSION MEDIA (U.S. CLS. 100, 101 AND 107).

FRED CARL, EXAMINING ATTORNEY

SN 85-196,315. DESHA PRODUCTIONS, INC., DBA ALLEY TO THE VALLEY, PALO ALTO, CA. FILED 12-13-2010.

Valley to the Alley

THE MARK CONSISTS OF STANDARD CHARACTERS WITHOUT CLAIM TO ANY PARTICULAR FONT, STYLE, SIZE, OR COLOR.

FOR EDUCATIONAL SERVICES, NAMELY, CONDUCTING SEMINARS, CONFERENCES, CLASSES AND WORKSHOPS IN THE FIELD OF TOPICS OF INTEREST TO WOMEN (U.S. CLS. 100, 101 AND 107).

SANJEEV VOHRA, EXAMINING ATTORNEY

**CLASS 41—(Continued).**

SN 85-202,734. SHUTTERBOX ENTERTAINMENT LLC, NAPERVILLE, IL. FILED 12-21-2010.

"How much fun can you have?"

THE MARK CONSISTS OF STANDARD CHARACTERS WITHOUT CLAIM TO ANY PARTICULAR FONT, STYLE, SIZE, OR COLOR.

FOR DIGITAL IMAGING SERVICES; FILM AND VIDEO PRODUCTION; FILM AND VIDEO TAPE FILM PRODUCTION; MEDIA PRODUCTION SERVICES, NAMELY, VIDEO AND FILM PRODUCTION; MOTION PICTURE CAMERA RENTAL SERVICES; PHOTOGRAPHIC AND VIDEO SERVICES, NAMELY, PHOTOGRAPHIC AND VIDEO CAPTURE; PHOTOGRAPHY; PHOTOGRAPHY SERVICES; PORTRAIT PHOTOGRAPHY; RENTAL OF CAMERAS; RENTAL OF IMAGE-RECORDED MAGNETIC TAPES; RENTAL OF MOTION PICTURES AND OF SOUND RECORDINGS; RENTAL OF MOVIE PROJECTORS AND ACCESSORIES; RENTAL OF PORTABLE MULTIMEDIA VIEWING TERMINALS; RENTAL OF PORTABLE PHOTOGRAPHY AND/OR VIDEOGRAPHY BOOTHS FOR TAKING OF PICTURES AND VIDEOS; RENTAL OF STAGE AND MOVIE EQUIPMENT, NAMELY, CAMERA EQUIPMENT, LIGHTING EQUIPMENT AND GRIP EQUIPMENT; RENTAL OF VIDEO CAMERAS (U.S. CLS. 100, 101 AND 107).

DORITT L. CARROLL, EXAMINING ATTORNEY

SN 85-208,955. INTEGRITY MEDIA, INC., MOBILE, AL. FILED 1-3-2011.

**INTEGRITY UNIVERSITY**

THE MARK CONSISTS OF STANDARD CHARACTERS WITHOUT CLAIM TO ANY PARTICULAR FONT, STYLE, SIZE, OR COLOR.

OWNER OF U.S. REG. NOS. 1,743,670, 3,017,428 AND OTHERS.

NO CLAIM IS MADE TO THE EXCLUSIVE RIGHT TO USE "UNIVERSITY", APART FROM THE MARK AS SHOWN.

FOR EDUCATIONAL SERVICES, NAMELY, PROVIDING COURSES OF INSTRUCTION AT THE UNDERGRADUATE, GRADUATE, POST-GRADUATE AND PROFESSIONAL LEVEL AND DISTRIBUTION OF COURSE MATERIAL IN CONNECTION THEREWITH (U.S. CLS. 100, 101 AND 107).

BRENDAN REGAN, EXAMINING ATTORNEY

**CLASS 41—(Continued).**

SN 85-210,981. THE CARTOON NETWORK, INC., ATLANTA, GA. FILED 1-5-2011.

**LOOP'D**

THE MARK CONSISTS OF STANDARD CHARACTERS WITHOUT CLAIM TO ANY PARTICULAR FONT, STYLE, SIZE, OR COLOR.

FOR ENTERTAINMENT SERVICES, NAMELY, PROVIDING A WEBSITE FEATURING AND ON-LINE ACTIVITY WHERE USERS CREATE THEIR OWN VIDEO CLIPS FROM EXISTING FOOTAGE (U.S. CLS. 100, 101 AND 107).

FRED CARL, EXAMINING ATTORNEY

SN 85-212,990. HANG TEN INTERACTIVE, INC., EVERETT, WA. FILED 1-7-2011.

THE MARK CONSISTS OF THE WORD "GAME" FOLLOWED BY THE WORD "SAMBA" WHERE THE "M" IS TILTED TO THE RIGHT; STYLIZED, CURVED, DOUBLE LINES APPEAR TO THE UPPER LEFT AND RIGHT OF "SAMBA" INDICATING MOVEMENT.

FOR ENTERTAINMENT SERVICES, NAMELY PROVIDING ONLINE INTERACTIVE VIDEO GAMES (U.S. CLS. 100, 101 AND 107).

FIRST USE 11-15-2010; IN COMMERCE 11-15-2010. ALICIA COLLINS, EXAMINING ATTORNEY

SN 85-212,997. HANG TEN INTERACTIVE, INC., EVERETT, WA. FILED 1-7-2011.

**GAMESAMBA**

THE MARK CONSISTS OF STANDARD CHARACTERS WITHOUT CLAIM TO ANY PARTICULAR FONT, STYLE, SIZE, OR COLOR.

FOR ENTERTAINMENT SERVICES, NAMELY PROVIDING ONLINE INTERACTIVE VIDEO GAMES (U.S. CLS. 100, 101 AND 107).

FIRST USE 11-15-2010; IN COMMERCE 11-15-2010. ALICIA COLLINS, EXAMINING ATTORNEY

**CLASS 41—(Continued).**

SN 85-215,321. AMERICAN COLLEGE OF RADIOLOGY, RESTON, VA. FILED 1-11-2011.

# JACR

THE MARK CONSISTS OF STANDARD CHARACTERS WITHOUT CLAIM TO ANY PARTICULAR FONT, STYLE, SIZE, OR COLOR.

OWNER OF U.S. REG. NO. 2,919,549.  
FOR PROVIDING AN ONLINE JOURNAL IN THE FIELD OF RADIOLOGY (U.S. CLS. 100, 101 AND 107).  
FIRST USE 1-1-2004; IN COMMERCE 1-1-2004.  
DAVID HOFFMAN, EXAMINING ATTORNEY

---

SN 85-215,678. WHOLE FOODS MARKET IP, L.P., AUSTIN, TX. FILED 1-12-2011.

## DO SOMETHING REEL

THE MARK CONSISTS OF STANDARD CHARACTERS WITHOUT CLAIM TO ANY PARTICULAR FONT, STYLE, SIZE, OR COLOR.

FOR ENTERTAINMENT SERVICES, NAMELY ORGANIZING AND CONDUCTING A FILM FESTIVAL (U.S. CLS. 100, 101 AND 107).  
INGA ERVIN, EXAMINING ATTORNEY

---

SN 85-220,103. BRATS IN BROADCASTING LLC, PEORIA, AZ. FILED 1-18-2011.

# BRATHEAD

THE MARK CONSISTS OF STANDARD CHARACTERS WITHOUT CLAIM TO ANY PARTICULAR FONT, STYLE, SIZE, OR COLOR.

FOR ENTERTAINMENT SERVICES, NAMELY, PROVIDING RADIO PROGRAMS IN THE FIELD OF INTERACTIVE TALK SHOWS COVERING LIFE AS CHILDREN OF GOVERNMENT AND MILITARY SERVICE MEMBERS (U.S. CLS. 100, 101 AND 107).  
TAMARA FRAZIER, EXAMINING ATTORNEY

**CLASS 41—(Continued).**

SN 85-221,390. PEARSON EDUCATION, INC., UPPER SADDLE RIVER, NJ. FILED 1-19-2011.

## MYPHILOSOPHYLAB

THE MARK CONSISTS OF STANDARD CHARACTERS WITHOUT CLAIM TO ANY PARTICULAR FONT, STYLE, SIZE, OR COLOR.

OWNER OF U.S. REG. NOS. 2,709,049, 3,229,285 AND OTHERS.

FOR EDUCATIONAL SERVICES, NAMELY, DEVELOPMENT AND DISSEMINATION OF EDUCATIONAL TOOLS, CONTENT, AND MATERIALS OF OTHERS TO UNIVERSITY PROFESSORS AND THEIR STUDENTS VIA THE INTERNET, NAMELY, DIGITAL TEXTBOOKS, INSTRUCTORS MANUALS, SUPPLEMENTARY READING MATERIALS, INSTRUCTIONAL MATERIALS IN THE NATURE OF SELF-ASSESSMENT AND STUDY TOOLS FOR STUDENTS, HOMEWORK ASSIGNMENTS, COURSE ASSESSMENT AND COURSE MANAGEMENT MATERIALS IN THE FIELD OF PHILOSOPHY (U.S. CLS. 100, 101 AND 107).

FIRST USE 8-13-2010; IN COMMERCE 8-13-2010.  
KAREN BRACEY, EXAMINING ATTORNEY

---

SN 85-221,812. PEARSON EDUCATION, INC., UPPER SADDLE RIVER, NJ. FILED 1-20-2011.

## MYRELIGIONLAB

THE MARK CONSISTS OF STANDARD CHARACTERS WITHOUT CLAIM TO ANY PARTICULAR FONT, STYLE, SIZE, OR COLOR.

OWNER OF U.S. REG. NOS. 2,709,049, 3,229,285 AND OTHERS.

FOR EDUCATIONAL SERVICES, NAMELY, DEVELOPMENT AND DISSEMINATION OF EDUCATIONAL TOOLS, CONTENT, AND MATERIALS OF OTHERS TO UNIVERSITY PROFESSORS AND THEIR STUDENTS VIA THE INTERNET, NAMELY, DIGITAL TEXTBOOKS, INSTRUCTORS MANUALS, SUPPLEMENTARY READING MATERIALS, INSTRUCTIONAL MATERIALS IN THE NATURE OF SELF-ASSESSMENT AND STUDY TOOLS FOR STUDENTS, HOMEWORK ASSIGNMENTS, COURSE ASSESSMENT AND COURSE MANAGEMENT MATERIALS IN THE FIELD OF RELIGIOUS STUDIES (U.S. CLS. 100, 101 AND 107).

FIRST USE 12-3-2010; IN COMMERCE 12-3-2010.  
KAREN BRACEY, EXAMINING ATTORNEY



**CLASS 41—(Continued).**

SN 85-222,190. PEARSON EDUCATION, INC., UPPER SADDLE RIVER, NJ. FILED 1-20-2011.

**MYSOCIALWORKLAB**

THE MARK CONSISTS OF STANDARD CHARACTERS WITHOUT CLAIM TO ANY PARTICULAR FONT, STYLE, SIZE, OR COLOR.

OWNER OF U.S. REG. NOS. 2,709,049, 3,229,285 AND OTHERS.

FOR EDUCATIONAL SERVICES, NAMELY, DEVELOPMENT AND DISSEMINATION OF EDUCATIONAL TOOLS, CONTENT, AND MATERIALS OF OTHERS TO UNIVERSITY PROFESSORS AND THEIR STUDENTS VIA THE INTERNET, NAMELY, DIGITAL TEXTBOOKS, INSTRUCTORS MANUALS, SUPPLEMENTARY READING MATERIALS, INSTRUCTIONAL MATERIALS IN THE NATURE OF SELF-ASSESSMENT AND STUDY TOOLS FOR STUDENTS, HOMEWORK ASSIGNMENTS, COURSE ASSESSMENT AND COURSE MANAGEMENT MATERIALS IN THE FIELD OF SOCIAL WORK (U.S. CLS. 100, 101 AND 107).

FIRST USE 1-12-2010; IN COMMERCE 1-12-2010.  
KAREN BRACEY, EXAMINING ATTORNEY

**CLASS 41—(Continued).**

SN 85-239,505. TWENTIETH CENTURY FOX FILM CORPORATION, LOS ANGELES, CA. FILED 2-10-2011.

**EXIT STRATEGY**

THE MARK CONSISTS OF STANDARD CHARACTERS WITHOUT CLAIM TO ANY PARTICULAR FONT, STYLE, SIZE, OR COLOR.

FOR ENTERTAINMENT SERVICES IN THE NATURE OF A TELEVISION SERIES FEATURING DRAMA; ENTERTAINMENT SERVICES IN THE NATURE OF NON-DOWNLOADABLE VIDEOS AND IMAGES FEATURING TELEVISION SHOWS AND ENTERTAINMENT TRANSMITTED VIA THE INTERNET AND WIRELESS COMMUNICATION NETWORKS; ON-LINE JOURNALS, NAMELY, BLOGS FEATURING PERSONAL OPINIONS IN THE FIELD OF GENERAL INTEREST AND DRAMA (U.S. CLS. 100, 101 AND 107).

ALICIA COLLINS, EXAMINING ATTORNEY

SN 85-229,174. GUN LAKE TRIBAL GAMING AUTHORITY, DORR, MI. FILED 1-28-2011.

**GUN LAKE CASINO PASSPORT**

THE MARK CONSISTS OF STANDARD CHARACTERS WITHOUT CLAIM TO ANY PARTICULAR FONT, STYLE, SIZE, OR COLOR.

NO CLAIM IS MADE TO THE EXCLUSIVE RIGHT TO USE "CASINO", APART FROM THE MARK AS SHOWN.

FOR CASINO AND ENTERTAINMENT SERVICES, NAMELY, LIVE PERFORMANCES FEATURING MUSICIANS AND SINGERS, DANCERS, MAGICIANS, ACTORS, ACROBATS, COMEDIANS AND PROVIDING NON-DOWNLOADABLE PRERECORDED MUSIC AND VIDEO ENTERTAINMENT IN NIGHT CLUBS AND ARRANGING AND CONDUCTING NIGHT CLUB ENTERTAINMENT EVENTS FEATURING PRERECORDED MUSIC AND VIDEOS; AMUSEMENT ARCADES; NIGHT CLUBS; CASINO SERVICES, NAMELY, OPERATION OF A FREQUENT PLAYERS' INCENTIVE PROGRAM (U.S. CLS. 100, 101 AND 107).

KATHLEEN M. VANSTON, EXAMINING ATTORNEY

SN 85-241,407. ALZHEIMER'S DISEASE AND RELATED DISORDERS ASSOCIATION, INC., CHICAGO, IL. FILED 2-14-2011.

**AAIC**

THE MARK CONSISTS OF STANDARD CHARACTERS WITHOUT CLAIM TO ANY PARTICULAR FONT, STYLE, SIZE, OR COLOR.

FOR EDUCATIONAL SERVICES, NAMELY, CONDUCTING CONFERENCES IN THE FIELD OF ALZHEIMER'S DISEASE AND RELATED DISORDERS (U.S. CLS. 100, 101 AND 107).

JAMES STEIN, EXAMINING ATTORNEY

**CLASS 42—SCIENTIFIC AND COMPUTER SERVICES**

SN 77-050,888. FORBES MEDI-TECH INC., VANCOUVER, CANADA, FILED 11-27-2006.



PRIORITY CLAIMED UNDER SEC. 44(D) ON CANADA APPLICATION NO. 1321240, FILED 10-23-2006, REG. NO. TMA772913, DATED 7-23-2010, EXPIRES 7-23-2025.

NO CLAIM IS MADE TO THE EXCLUSIVE RIGHT TO USE "INC.", APART FROM THE MARK AS SHOWN.

THE MARK CONSISTS OF TWO OPPOSITE CURVED LINES THAT INTERSECT AT THE BOTTOM BUT DO NOT JOIN AT THE TOP, FORMING A HEART DESIGN.

FOR DEVELOPMENT AND RESEARCH RELATING TO NUTRACEUTICALS, DIETARY AND NATURAL FOOD SUPPLEMENTS, AND FUNCTIONAL FOODS (U.S. CLS. 100 AND 101).

MICHAEL ENGEL, EXAMINING ATTORNEY

---

SN 77-595,225. BIG EFFIN GARAGE, LLC, AUBURN HILLS, MI. FILED 10-17-2008.

**BIG EFFIN GARAGE**

THE MARK CONSISTS OF STANDARD CHARACTERS WITHOUT CLAIM TO ANY PARTICULAR FONT, STYLE, SIZE, OR COLOR.

FOR HOSTING AN ONLINE COMMUNITY FOR MUSICIANS AND MUSIC FANS FEATURING INFORMATION ABOUT MUSIC, MUSICIANS AND MUSICAL GROUPS; COMPUTER SERVICES, NAMELY, CREATING AN ONLINE COMMUNITY FOR REGISTERED MUSICIANS AND MUSIC FANS TO UPLOAD, DOWNLOAD, OR MIX MUSIC TRACKS, SHOWCASE THEIR SKILLS, GET FEEDBACK FROM PEERS, FORM VIRTUAL GROUPS, PLAY MUSIC TOGETHER, AND ENGAGE IN SOCIAL AND PROFESSIONAL NETWORKING (U.S. CLS. 100 AND 101).

NAAKWAMA ANKRAH, EXAMINING ATTORNEY

**CLASS 42—(Continued).**

SN 77-630,589. MEADZ SOCIAL CHANGE, LLC, AKA MEADZ, ITHACA, NY. FILED 12-10-2008.

**Meadz**

THE MARK CONSISTS OF STANDARD CHARACTERS WITHOUT CLAIM TO ANY PARTICULAR FONT, STYLE, SIZE, OR COLOR.

FOR COMPUTER SERVICE, ACTING AS AN APPLICATION SERVICE PROVIDER IN THE FIELD OF KNOWLEDGE MANAGEMENT TO HOST COMPUTER APPLICATION SOFTWARE FOR CREATING SEARCHABLE DATABASES OF INFORMATION AND DATA TO ALLOW USERS TO PERFORM, ON-LINE, THE COLLECTING AND ANALYZING OF DIFFERENT TYPES OF OPINION SURVEYS; COMPUTER SERVICES, NAMELY, CREATING AN ON-LINE COMMUNITY FOR REGISTERED USERS TO PARTICIPATE IN DISCUSSIONS, GET FEEDBACK FROM THEIR PEERS, FORM VIRTUAL COMMUNITIES, AND ENGAGE IN SOCIAL NETWORKING; COMPUTER SERVICES, NAMELY, CREATING AND MAINTAINING WEB SITES FOR OTHERS; COMPUTER SERVICES, NAMELY, CREATING INDEXES OF INFORMATION, SITES AND OTHER RESOURCES AVAILABLE ON COMPUTER NETWORKS; COMPUTER SERVICES, NAMELY, HOSTING AND MAINTAINING AN ON-LINE WEB SITE FOR OTHERS TO POST, RATE, AND DISCUSS CONTENT, FIND AND UTILIZE A DIRECTORY OF WEBSITES AND RESOURCES OF PROGRESSIVE NON-PROFIT ORGANIZATIONS, ASSOCIATIONS, AND ACTIVISTS, UTILIZE AS A CONTENT MANAGEMENT SYSTEM, FIND AND USE WEBSITE TEMPLATES TO BUILD WEBSITES, FIND INFORMATION AND RESOURCES PROVIDED BY OTHER USERS, UTILIZE SEARCH ENGINE TOOLS, UTILIZE MESSAGING SYSTEMS TO COMMUNICATE WITH OTHERS, AND USE SOFTWARE APPLICATIONS, NAMELY, PETITIONS AND SOFTWARE APPLICATIONS FOR USE IN TARGETED EMAIL CAMPAIGNS; COMPUTER SERVICES, NAMELY, HOSTING ON-LINE WEB FACILITIES FOR OTHERS FOR ORGANIZING AND CONDUCTING ONLINE MEETINGS, GATHERINGS, AND INTERACTIVE DISCUSSIONS; COMPUTER SERVICES, NAMELY, PROVIDING AN INTERACTIVE WEB SITE THAT ALLOWS USERS TO COLLECT, STORE, MANAGE, DELIVER AND SHOWCASE ELECTRONIC AND PAPER-BASED CONTENT; HOSTING AN ONLINE WEBSITE FEATURING A DIRECTORY OF WEBSITES AND RESOURCES OF PROGRESSIVE NON-PROFIT ORGANIZATIONS, ASSOCIATIONS, AND ACTIVISTS, A CONTENT MANAGEMENT SYSTEM, WEBSITE TEMPLATES, AGGREGATION, STORAGE AND DISPLAY OF INFORMATION PROVIDED BY USERS, SEARCH ENGINE TOOLS, MESSAGING SYSTEMS TO COMMUNICATE WITH OTHERS, AND SOFTWARE APPLICATIONS, NAMELY, PETITIONS AND SOFTWARE APPLICATIONS FOR USE IN TARGETED EMAIL CAMPAIGNS (U.S. CLS. 100 AND 101).

KARANENDRA S. CHHINA, EXAMINING ATTORNEY

**CLASS 42—(Continued).**

SN 77-712,716. PHILLIPS, WILLIAM MICHAEL, RALEIGH, NC. FILED 4-13-2009.

**CLASS 42—(Continued).**

SN 77-835,854. ELECTRONIC KEEL, LLC, ARLINGTON, VA. FILED 9-27-2009.

# Feedback Quotient

THE MARK CONSISTS OF STANDARD CHARACTERS WITHOUT CLAIM TO ANY PARTICULAR FONT, STYLE, SIZE, OR COLOR.

NO CLAIM IS MADE TO THE EXCLUSIVE RIGHT TO USE "FEEDBACK", APART FROM THE MARK AS SHOWN.

FOR COMPUTER SERVICE, NAMELY, ACTING AS AN APPLICATION SERVICE PROVIDER IN THE FIELD OF KNOWLEDGE MANAGEMENT TO HOST COMPUTER APPLICATION SOFTWARE FOR CREATING SEARCHABLE DATABASES OF INFORMATION AND DATA (U.S. CLS. 100 AND 101).

FIRST USE 4-3-2009; IN COMMERCE 10-25-2009.  
AMEEN IMAM, EXAMINING ATTORNEY



SN 77-798,511. HYDE, DONALD V., HENDERSON, NV. FILED 8-6-2009.

# VESSEL VANGUARD

THE MARK CONSISTS OF STANDARD CHARACTERS WITHOUT CLAIM TO ANY PARTICULAR FONT, STYLE, SIZE, OR COLOR.

NO CLAIM IS MADE TO THE EXCLUSIVE RIGHT TO USE "VESSEL", APART FROM THE MARK AS SHOWN.

FOR COMPUTER SERVICES, NAMELY, CREATING AND HOSTING AN INTERACTIVE WEB SITE THAT ALLOWS USERS TO UPLOAD AND STORE BOAT AND BOAT EQUIPMENT INFORMATION AND MAINTAIN MAINTENANCE LOGS AND ONLINE DATABASES FOR OWNERS OF BOATS HAVING MULTIPLE EQUIPMENT CONFIGURATIONS, RECEIVING AND LOGGING OWNERSHIP RECORDS, EQUIPMENT CONFIGURATIONS, OPERATING SYSTEMS AND COMPONENT PLANS, RECEIVE AUTOMATED ALERTS AND FOLLOW-UPS IN ADVANCE OF DUE MAINTENANCE BASED ON CALENDAR DATES OR HOURS OF OPERATION FOR SCHEDULING AND PERFORMING MAINTENANCE, INSPECTIONS AND WINTER WEATHERIZATION, AUTOMATICALLY RECEIVING RECORDS AND LOGGING MAINTENANCE COMPLETIONS, RECALIBRATING AND LOGGING DATA UPON COMPLETION OF WORK, RECEIVING AUTOMATED SEARCHABLE PERMANENT RECORDS AND BACKUPS OF MASTER EQUIPMENT LISTS, TASK LISTS, DEFERRED TASK LISTS, MAINTENANCE CALENDARS, SOCIAL CALENDARS, BOAT DOCUMENTATION, INSURANCE FILES AND PHOTOS, GALLEY STORES, SPARES AND FLUIDS STORES, OPERATING MANUALS, ACCOUNTING RECORDS, CONTRACTOR RECORDS, AND SHIPS' MAINTENANCE LOGS FOR DOWNLOADING AND ARCHIVAL REVIEW (U.S. CLS. 100 AND 101).

DAVID ELTON, EXAMINING ATTORNEY

# ELECTRONIC KEEL

THE MARK CONSISTS OF STANDARD CHARACTERS WITHOUT CLAIM TO ANY PARTICULAR FONT, STYLE, SIZE, OR COLOR.

FOR CONSULTING SERVICES IN THE FIELD OF RECONFIGURABLE INTEGRATED INFORMATION DISTRIBUTION COMPUTER HARDWARE AND SOFTWARE SYSTEMS (U.S. CLS. 100 AND 101).

CHARLOTTE CORWIN, EXAMINING ATTORNEY



SN 77-835,855. ELECTRONIC KEEL, LLC, ARLINGTON, VA. FILED 9-27-2009.

# EKEEL

THE MARK CONSISTS OF STANDARD CHARACTERS WITHOUT CLAIM TO ANY PARTICULAR FONT, STYLE, SIZE, OR COLOR.

FOR CONSULTING SERVICES IN THE FIELD OF RECONFIGURABLE INTEGRATED INFORMATION DISTRIBUTION COMPUTER HARDWARE AND SOFTWARE SYSTEMS (U.S. CLS. 100 AND 101).

CHARLOTTE CORWIN, EXAMINING ATTORNEY

**CLASS 42—(Continued).**

SN 77-843,300. THE MEDICAL AFFAIRS COMPANY, LLC,  
KENNESAW, GA. FILED 10-7-2009.

## OPTIMIZING SCIENTIFIC EXCHANGE

THE MARK CONSISTS OF STANDARD CHARACTERS WITHOUT CLAIM TO ANY PARTICULAR FONT, STYLE, SIZE, OR COLOR.

NO CLAIM IS MADE TO THE EXCLUSIVE RIGHT TO USE "SCIENTIFIC EXCHANGE", APART FROM THE MARK AS SHOWN.

FOR MEDICAL AND SCIENTIFIC RESEARCH LIAISON SERVICES, NAMELY, CONSULTING REGARDING CLINICAL STUDIES IN THE FIELDS OF HEALTH CARE, MEDICINE, PHARMACOLOGY AND BIOTECHNOLOGY; CONSULTING REGARDING SCIENTIFIC AND TECHNICAL RESEARCH ASPECTS OF CLINICAL TRIALS; DESIGNING CLINICAL TRIALS FOR DRUG AND MEDICAL PRODUCT DEVELOPMENT PURPOSES; PROVIDING MEDICAL AND SCIENTIFIC RESEARCH INFORMATION IN THE FIELD OF CLINICAL STUDIES, NAMELY, MONITORING AND REPORTING OF CLINICAL STUDIES, CONSUMER FEEDBACK, AND INDUSTRY NEWS REGARDING DRUGS, MEDICAL PRODUCTS, AND MEDICAL PROCEDURES; DEVELOPMENT OF VOLUNTARY STANDARDS AND PRACTICES FOR RESEARCH AND BUSINESS IN THE FIELDS OF HEALTH CARE, MEDICINE, MEDICAL DEVICE DEVELOPMENT, PHARMACOLOGY AND BIOTECHNOLOGY (U.S. CLS. 100 AND 101).

FIRST USE 11-0-2008; IN COMMERCE 11-0-2008.  
JULIE WATSON, EXAMINING ATTORNEY

SN 77-847,292. AEROSURVEY, INC., MANHATTAN, KS.  
FILED 10-13-2009.

## AEROSURVEY

THE MARK CONSISTS OF STANDARD CHARACTERS WITHOUT CLAIM TO ANY PARTICULAR FONT, STYLE, SIZE, OR COLOR.

OWNER OF U.S. REG. NO. 2,325,485.

FOR REMOTE SENSING USING AIRBORNE AND GROUND-BASED VISIBLE CAMERAS AND IMAGING SPECTROMETERS TO MEASURE PHYSICAL PROPERTIES RELEVANT TO GEOPHYSICAL, ENVIRONMENTAL AND AGRICULTURAL ANALYSES; SPECTROSCOPIC RESEARCH AND DEVELOPMENT; GROUND TRUTH DATA COLLECTION SERVICES, NAMELY, THE DIRECT MEASUREMENT OF GEOPHYSICAL PROPERTIES IN THE FIELD OF ENVIRONMENTAL MONITORING, INDUSTRIAL MONITORING, AGRICULTURAL MONITORING, NATIONAL DEFENSE, AND HOMELAND SECURITY IN ORDER TO COMPARE THOSE MEASUREMENTS WITH EXPERIMENTAL DATA OF THE SAME TYPE WHICH WERE REMOTELY COLLECTED FOR PURPOSES OF EVALUATING SENSORS AND TECHNIQUES FOR REMOTE DATA COLLECTION; RESEARCH SERVICES IN THE FIELD OF SPECTROSCOPIC PHENOMENOLOGY; CALIBRATION, PERFORMANCE EVALUATION, AND FIELD-TESTING OF SPECTROSCOPIC INSTRUMENTATION; FIELD DATA COLLECTION SERVICES INVOLVING THE DIRECT MEASUREMENT OR REMOTE SENSING OF PHYSICAL PROPERTIES BY SCIENTIFIC INSTRUMENTATION FOR GEOPHYSICAL, ENVIRONMENTAL AND AGRICULTURAL ANALYSES; FIELD-

**CLASS 42—(Continued).**

BASED REMOTE SENSING USING AIRBORNE AND GROUND-BASED VISIBLE CAMERAS AND IMAGING SPECTROMETERS TO MEASURE PHYSICAL PROPERTIES RELEVANT TO GEOPHYSICAL, ENVIRONMENTAL AND AGRICULTURAL ANALYSES; MONITORING INDUSTRIAL ACTIVITIES WITH SCIENTIFIC INSTRUMENTS TO MEASURE PHYSICAL AND SPECTROSCOPIC PROPERTIES OF INDUSTRIAL EFFLUENTS AND INDUSTRIAL STRUCTURES; ENVIRONMENTAL APPLICATIONS OF SPECTRAL SENSORS, NAMELY, SPECTROSCOPIC MEASUREMENTS OF EFFLUENTS FROM SMOKESTACKS FOR POLLUTION STUDIES, AS WELL AS AIRBORNE POLLUTANTS FOR AIR QUALITY AND WORKER SAFETY STUDIES; LABORATORY TESTING SERVICES, NAMELY, TESTING OF SPECTROSCOPIC INSTRUMENTATION TO EVALUATE PERFORMANCE, TESTING OF ANALYTICAL METHODOLOGIES UNDER DEVELOPMENT FOR REMOTE SENSING APPLICATIONS, TESTING OF MATERIALS UNDER DEVELOPMENT FOR USE IN REMOTE SENSING APPLICATIONS; SPECTROSCOPIC TECHNOLOGY SERVICES, NAMELY, CONSULTING SERVICES RELATED TO THE DEVELOPMENT OF INSTRUMENTATION AND METHODOLOGIES RELATED TO REMOTE SENSING APPLICATIONS; CONTRACT ANALYTICAL SERVICES, NAMELY, CHEMICAL ANALYSIS; CONTRACT ANALYTICAL SERVICES, NAMELY, SPECTROSCOPIC MEASUREMENT OF OPTICAL PROPERTIES OF SOLID, LIQUID, AND GASEOUS MATERIALS IN THE FIELDS OF ENVIRONMENTAL MONITORING, INDUSTRIAL MONITORING, AGRICULTURAL MONITORING, NATIONAL DEFENSE, AND HOMELAND SECURITY; AGRICULTURAL AND INDUSTRIAL PROCESS MONITORING, NAMELY, CHEMICAL ANALYSIS AND SPECTROSCOPIC ANALYSIS OF INDUSTRIAL PROCESS WASTE AND BI-PRODUCTS FOR EFFICIENCY PURPOSES AND CHEMICAL AND SPECTROSCOPIC ANALYSIS OF AGRICULTURAL CROPS, LAND, FERTILIZERS AND AGRICULTURAL CHEMICALS FOR THE PURPOSE OF IMPROVING CROP PRODUCTION; BIOMEDICAL SENSOR DEVELOPMENT FOR OTHERS; ENVIRONMENTAL ANALYSIS, NAMELY, ANALYSIS OF CHEMICAL CONSTITUENCY AND MEASUREMENT OF GEOPHYSICAL PROPERTIES OF AIR, WATER, AND SOIL SAMPLES FOR THE PURPOSE OF INVESTIGATING ENVIRONMENTAL ISSUES; GEOPHYSICAL AND ATMOSPHERIC RESEARCH (U.S. CLS. 100 AND 101).

FIRST USE 7-0-1993; IN COMMERCE 8-0-1993.  
KELLEY WELLS, EXAMINING ATTORNEY

SN 77-849,502. AFILIAS LIMITED, DUBLIN 24, IRELAND,  
FILED 10-15-2009.

## SITECERTAIN

THE MARK CONSISTS OF STANDARD CHARACTERS WITHOUT CLAIM TO ANY PARTICULAR FONT, STYLE, SIZE, OR COLOR.

FOR MONITORING THE INFRASTRUCTURE-RELATED TECHNICAL PERFORMANCE OF WEBSITES AND WEB SERVERS FOR OTHERS; PROVIDING ONLINE NON-DOWNLOADABLE SOFTWARE USED TO PROVIDE DOMAIN NAME SYSTEM (DNS) FAILOVER SERVICES FOR PURPOSES OF INFRASTRUCTURE-RELATED MONITORING OF WEB SYSTEMS AND MAINTAINING PROPER TECHNICAL PERFORMANCE AND TRAFFIC (U.S. CLS. 100 AND 101).

CORY BOONE, EXAMINING ATTORNEY

**CLASS 42—(Continued).**

SN 77-853,379. JPD MEDIA, INC., WEST HOLLYWOOD, CA. FILED 10-20-2009.



**DURIEDESIGN**

NO CLAIM IS MADE TO THE EXCLUSIVE RIGHT TO USE "DESIGN", APART FROM THE MARK AS SHOWN.

THE NAME(S), PORTRAIT(S), AND/OR SIGNATURE(S) SHOWN IN THE MARK IDENTIFIES JAMIE DURIE, WHOSE CONSENT(S) TO REGISTER IS MADE OF RECORD.

THE MARK CONSISTS OF THE HANDWRITTEN NAME "JAMIE DURIE" ABOVE THE WORDS "DURIE DESIGN" WITH A BACKWARDS "D" BETWEEN "DURIE" AND "DESIGN".

FOR LANDSCAPE ARCHITECTURAL DESIGN (U.S. CLS. 100 AND 101).

JAY BESCH, EXAMINING ATTORNEY

**CLASS 42—(Continued).**

SN 77-936,706. CONTROL TECHNOLOGIES, INC., WILLISTON, VT. FILED 2-16-2010.

**TRACTREE**

THE MARK CONSISTS OF STANDARD CHARACTERS WITHOUT CLAIM TO ANY PARTICULAR FONT, STYLE, SIZE, OR COLOR.

FOR ENGINEERING SERVICES FOR BUILDING AND PROPERTY CONDITION ASSESSMENT, FACILITY MANAGEMENT, REPAIR AND RESTORATION, BUILDING INSTRUMENTATION AND MONITORING, AND ENVIRONMENTAL CONSULTING (U.S. CLS. 100 AND 101).

FIRST USE 6-11-2009; IN COMMERCE 6-11-2009.

ALYSSA STEEL, EXAMINING ATTORNEY

SN 77-858,039. J&L MARKETING, INC., LOUISVILLE, KY. FILED 10-27-2009.

**BENGAGING**

THE MARK CONSISTS OF STANDARD CHARACTERS WITHOUT CLAIM TO ANY PARTICULAR FONT, STYLE, SIZE, OR COLOR.

FOR DEVELOPING WEBSITES FOR OTHERS FOR DIRECT MARKETING PURPOSES; DEVELOPING WEBSITES FOR OTHERS TO FACILITATE MARKETING EVENTS AND CAMPAIGNS (U.S. CLS. 100 AND 101).

NAPOLEON SHARMA, EXAMINING ATTORNEY

SN 77-936,719. CONTROL TECHNOLOGIES, INC., WILLISTON, VT. FILED 2-16-2010.

**A GREENER WAY TO SERVICE.**

THE MARK CONSISTS OF STANDARD CHARACTERS WITHOUT CLAIM TO ANY PARTICULAR FONT, STYLE, SIZE, OR COLOR.

FOR ENGINEERING SERVICES FOR BUILDING AND PROPERTY CONDITION ASSESSMENT, FACILITY MANAGEMENT, REPAIR AND RESTORATION, BUILDING INSTRUMENTATION AND MONITORING, AND ENVIRONMENTAL CONSULTING (U.S. CLS. 100 AND 101).

FIRST USE 6-11-2009; IN COMMERCE 6-11-2009.

ALYSSA STEEL, EXAMINING ATTORNEY

SN 77-903,879. CITIZEN MEDIA PVT. LTD, SHIMLA, INDIA, FILED 1-2-2010.

**INSTAPRESS**

THE MARK CONSISTS OF STANDARD CHARACTERS WITHOUT CLAIM TO ANY PARTICULAR FONT, STYLE, SIZE, OR COLOR.

FOR INTERNET SERVICES, NAMELY, CREATING INDEXES OF INFORMATION, SITES AND OTHER RESOURCES AVAILABLE ON GLOBAL COMPUTER NETWORKS FOR OTHERS; INTERNET SERVICES, NAMELY, PROVIDING SEARCHING, BROWSING AND RETRIEVING OF INFORMATION, SITES, AND OTHER RESOURCES AVAILABLE ON GLOBAL COMPUTER NETWORKS FOR OTHERS (U.S. CLS. 100 AND 101).

FIRST USE 10-6-2009; IN COMMERCE 10-6-2009.

NAPOLEON SHARMA, EXAMINING ATTORNEY

SN 77-937,021. BAGDASARYAN, VAGRAM, GLENDALE, CA. FILED 2-16-2010.

**SIVIDYNE**

THE MARK CONSISTS OF STANDARD CHARACTERS WITHOUT CLAIM TO ANY PARTICULAR FONT, STYLE, SIZE, OR COLOR.

FOR ENGINEERING SERVICES, NAMELY, CHEMICAL ENGINEERING; TECHNOLOGY CONSULTATION AND RESEARCH IN THE FIELD OF CHEMICAL ENGINEERING; TESTING, ANALYSIS AND EVALUATION OF MATERIALS, NAMELY, METALS; FUEL CELL RESEARCH AND DEVELOPMENT (U.S. CLS. 100 AND 101).

LANA PHAM, EXAMINING ATTORNEY

**CLASS 42—(Continued).**

SN 77-939,027. CONTROL TECHNOLOGIES, INC., WILLISTON, VT. FILED 2-18-2010.



THE MARK CONSISTS OF A TREE IMAGE WITH GEAR FLOWERS, AND A GRAPHIC OF A SUN CIRCLE IN THE BACKGROUND. BELOW THE GRAPHIC IS THE STYLIZED LETTERING "TRAC TREE" WITH THE TERM "TREE" INSIDE THE LETTER "C" IN "TRAC". THE SUN GRAPHIC AND THE TERM "TRAC" HAVING SHADOWING.

FOR ENGINEERING SERVICES FOR BUILDING AND PROPERTY CONDITION ASSESSMENT, FACILITY MANAGEMENT, REPAIR AND RESTORATION, BUILDING INSTRUMENTATION AND MONITORING, AND ENVIRONMENTAL CONSULTING (U.S. CLS. 100 AND 101).

FIRST USE 6-11-2009; IN COMMERCE 6-11-2009.  
ALYSSA STEEL, EXAMINING ATTORNEY

SN 77-945,240. RIPPL, INC., SPANISH FORT, AL. FILED 2-25-2010.



THE COLOR(S) ROYAL BLUE, WHITE, AND RED IS/ARE CLAIMED AS A FEATURE OF THE MARK.

THE MARK CONSISTS OF ROYAL BLUE CIRCLE WITH A WHITE RING, THEN A ROYAL BLUE RING, THEN A WHITE RING, THEN ENDING WITH A ROYAL BLUE RING. THE WORDS "RIPPLUSA" ARE WRITTEN IN WHITE, EXCEPT FOR THE "S" WHICH IS CURVED LIKE AN "S" IN RED AND WHITE STRIPES.

FOR COMPUTER SERVICES, NAMELY, CREATING AN ON-LINE COMMUNITY FOR REGISTERED USERS TO PARTICIPATE IN DISCUSSIONS, GET FEEDBACK FROM THEIR PEERS, FORM VIRTUAL COMMUNITIES, AND ENGAGE IN SOCIAL NETWORKING FEATURING THE ABILITY TO DEVELOP RELATIONSHIPS; COMPUTER SERVICES IN THE NATURE OF CUSTOMIZED WEB PAGES FEATURING USER-DEFINED INFORMATION, PERSONAL PROFILES AND INFORMATION; PROVIDING A WEB SITE THAT GIVES COMPUTER USERS THE ABILITY TO UPLOAD, EXCHANGE AND SHARE PHOTOS, VIDEOS AND VIDEO LOGS (U.S. CLS. 100 AND 101).

KELLY BOULTON, EXAMINING ATTORNEY

**CLASS 42—(Continued).**

SN 77-958,866. MISSION SOLUTIONS, LLC, BIRMINGHAM, AL. FILED 3-15-2010.



THE MARK CONSISTS OF THE LETTERS "M", "S" AND "E".

FOR SYSTEMS ENGINEERING SERVICES, NAMELY, ELECTRONIC SYSTEMS EVALUATIONS, TESTING, ASSESSMENTS, AND RESEARCH CARRIED OUT IN THE FIELDS OF WEAPONS AND WEAPONS SUPPORT SYSTEMS, WEAPONS CONTROL SOFTWARE, MILITARY WARNING SYSTEMS, MILITARY SUPPORT SERVICES, WEAPONS DEPLOYMENT, AND LOGISTICAL SUPPORT SYSTEMS; SYSTEMS ENGINEERING SERVICES, NAMELY, MIGRATING LEGACY AND PROPRIETARY SYSTEMS TO OPEN ARCHITECTURE FORMS; ENGINEERING SERVICES, NAMELY, ENSURING THAT THE QUALITY OF EVALUATED ELECTRONIC SYSTEMS MEETS PREDEFINED MANUFACTURING QUALITY STANDARDS UPON DELIVERY OF THOSE SYSTEMS TO A FINAL USE DESTINATION; CONDUCTING QUALITY COMPLIANCE AUDITS ON ELECTRONIC SYSTEMS AND CONDUCTING QUALITY VERIFICATION SERVICES ON ELECTRONIC SYSTEMS; SOFTWARE DEVELOPMENT SERVICES, NAMELY, COMPUTER PROGRAMMING AND SOFTWARE DESIGN, DEVELOPMENT, AND DEPLOYMENT FOR OTHERS; SOFTWARE DEVELOPMENT SERVICES, NAMELY, WRITING SOFTWARE FOR AND CONFIGURING ADVANCED TACTICAL DISPLAY SYSTEMS IN THE FIELD OF MILITARY DEFENSE; SYSTEMS INTEGRATION SERVICES, NAMELY, THE DESIGN AND IMPLEMENTATION OF INTEROPERABILITY STANDARDS WITHIN LEGACY AND OFF THE SHELF ELECTRONIC SYSTEMS; ENGINEERING SERVICES, NAMELY, DESIGNING UPGRADES TO MILITARY AND DEFENSE ELECTRONIC SYSTEMS; COMPUTER SOFTWARE DEVELOPMENT FOR OTHERS; UPDATING OF COMPUTER SOFTWARE FOR OTHERS; TECHNICAL SUPPORT SERVICES, NAMELY, DIAGNOSING COMPUTER HARDWARE AND SOFTWARE PROBLEMS; INFORMATION TECHNOLOGY SERVICES, NAMELY, DESIGNING NETWORK SYSTEMS TOPOLOGY STRATEGY AND IMPLEMENTATIONS IN THE FIELDS OF MILITARY, GOVERNMENT, AND MILITARY SUPPORT SERVICES TO MEET PREDEFINED NETWORK PERFORMANCE LEVELS AND PREDEFINED NETWORK DEPLOYMENT INTEGRATION GOALS; COMPUTER AND COMMUNICATIONS NETWORKS DESIGN AND COMPUTER NETWORK VALIDATION AND VERIFICATION SERVICES IN ACCORDANCE WITH PRE-DEFINED STANDARDS, NAMELY, VALIDATING THAT A SELECTED COMPUTER NETWORK MEETS THE DESIGN GOALS AND PERFORMANCE LEVELS FOR WHICH IT WAS DESIGNED (U.S. CLS. 100 AND 101).

FIRST USE 10-31-2009; IN COMMERCE 10-31-2009.  
EUGENIA MARTIN, EXAMINING ATTORNEY

**CLASS 42—(Continued).**

SN 77-966,408. NORMAN, DANELL, ORANGE, CA. AND RAMBAYON, DYAN, ORANGE, CA. AND RAMBAYON, ROY, ORANGE, CA. AND WAKEFIELD, MARK, ORANGE, CA. FILED 3-23-2010.

## Recipes in a Pinch

THE MARK CONSISTS OF STANDARD CHARACTERS WITHOUT CLAIM TO ANY PARTICULAR FONT, STYLE, SIZE, OR COLOR.

NO CLAIM IS MADE TO THE EXCLUSIVE RIGHT TO USE "RECIPES", APART FROM THE MARK AS SHOWN.

FOR PROVIDING A WEB SITE FEATURING TEMPORARY USE OF NON-DOWNLOADABLE SOFTWARE ALLOWING WEB SITE USERS TO UPLOAD ON-LINE VIDEOS FOR SHARING WITH OTHERS FOR ENTERTAINMENT PURPOSES; COMPUTER SERVICES, NAMELY, CREATING ON-LINE VIRTUAL COMMUNITIES FOR REGISTERED USERS TO ORGANIZE GROUPS AND EVENTS, PARTICIPATE IN DISCUSSIONS, AND ENGAGE IN SOCIAL, BUSINESS AND COMMUNITY NETWORKING; COMPUTER SERVICES, NAMELY, HOSTING WEBSITES FOR OTHERS FOR ORGANIZING AND CONDUCTING MEETINGS, EVENTS AND INTERACTIVE DISCUSSIONS VIA COMMUNICATION NETWORKS; APPLICATION SERVICE PROVIDER (ASP) SERVICES, NAMELY, HOSTING COMPUTER SOFTWARE APPLICATIONS OF OTHERS; APPLICATION SERVICE PROVIDER (ASP) FEATURING SOFTWARE TO ENABLE OR PROVIDE FOR THE UPLOADING, DOWNLOADING, STREAMING, POSTING, DISPLAYING, BLOGGING, LINKING, SHARING OR OTHERWISE PROVIDING ELECTRONIC MEDIA OR INFORMATION OVER COMMUNICATION NETWORKS; PROVIDING AN ONLINE NETWORK SERVICE THAT ENABLES USERS TO TRANSFER PERSONAL IDENTIFY DATA TO AND SHARE PERSONAL IDENTIFY DATA WITH AND AMONG MULTIPLE WEBSITES; PROVIDING A WEB SITE FEATURING TECHNOLOGY THAT ENABLES ONLINE USERS TO CREATE PERSONAL PROFILES FEATURING SOCIAL NETWORKING INFORMATION AND TO TRANSFER AND SHARE SUCH INFORMATION AMONG MULTIPLE WEBSITES; PROVIDING TEMPORARY USE OF NON-DOWNLOADABLE SOFTWARE APPLICATIONS FOR SOCIAL NETWORKING, CREATING A VIRTUAL COMMUNITY, AND TRANSMISSION OF AUDIO, VIDEO, PHOTOGRAPHIC IMAGES, TEXT, GRAPHICS AND DATA; COMPUTER SERVICES IN THE NATURE OF CUSTOMIZED WEB PAGES FEATURING USER-DEFINED OR SPECIFIED INFORMATION, PERSONAL PROFILES, AUDIO, VIDEO, PHOTOGRAPHIC IMAGES, TEXT, GRAPHICS AND DATA; COMPUTER SERVICES, NAMELY, HOSTING ONLINE WEB SITES FOR OTHERS FOR ORGANIZING AND CONDUCTING ONLINE MEETINGS, GATHERINGS, AND INTERACTIVE DISCUSSIONS; COMPUTER SERVICES IN THE NATURE OF CUSTOMIZED WEB PAGES FEATURING USER-DEFINED INFORMATION, PERSONAL PROFILES AND INFORMATION; COMPUTER SERVICES, NAMELY, CREATING AN ON-LINE COMMUNITY FOR REGISTERED USERS TO FORM VIRTUAL COMMUNITIES FEATURING RECIPES AND COOKING (U.S. CLS. 100 AND 101).

ALYSSA STEEL, EXAMINING ATTORNEY

**CLASS 42—(Continued).**

SN 77-980,816. PATNI COMPUTER SYSTEMS LIMITED, MUMBAI, INDIA, FILED 8-29-2008.

**Patni PLUS**  
 Engage | Enable | Excel

OWNER OF INDIA REG. NO. 1707785, DATED 8-7-2008, EXPIRES 8-7-2018.

OWNER OF U.S. REG. NO. 2,891,128.

THE MARK CONSISTS OF THE WORDS "PATNI PLUS" IN STYLIZED LETTERING ABOVE A LINE DEVICE, ALL ABOVE THE WORDS "ENGAGE", "ENABLE" AND "EXCEL," WITH A THIN VERTICAL LINE BETWEEN "ENGAGE" AND "ENABLE" AS WELL AS BETWEEN "ENABLE" AND "EXCEL".

FOR RECOVERY OF COMPUTER DATA; CONSULTANCY IN THE FIELD OF COMPUTER HARDWARE; COMPUTER RENTAL (U.S. CLS. 100 AND 101).

NORA BUCHANAN WILL, EXAMINING ATTORNEY

SN 79-075,940. GEOSERVICES EQUIPEMENTS, FRANCE, FILED 7-7-2009.



OWNER OF INTERNATIONAL REGISTRATION 1021107 DATED 7-7-2009, EXPIRES 7-7-2019.

OWNER OF U.S. REG. NOS. 2,454,655 AND 3,048,510.

NO CLAIM IS MADE TO THE EXCLUSIVE RIGHT TO USE "ISOTOPE LOGGING", APART FROM THE MARK AS SHOWN.

THE COLOR(S) BLACK, SHADES OF GREEN, SHADES OF YELLOW, SHADES OF RED AND BLUE IS/ARE CLAIMED AS A FEATURE OF THE MARK.

CLAIMED COLOURS: A LARGE SPHERE PROGRESSING FROM PURPLE ON THE OUTSIDE (CYAN 100/MAGENTA 82/YELLOW 4, BLACK 24) TO MAGENTA ON THE INSIDE (CYAN 5/MAGENTA 100/YELLOW 42/BLACK 1). SMALL OLIVE-GREEN SPHERES: THE SHADING PROGRESSING FROM GREEN ON THE OUTSIDE (CYAN 100/MAGENTA 18/YELLOW 100/BLACK 18) TO OLIVE GREEN ON THE INSIDE (CYAN 13/MAGENTA 1/YELLOW 100/BLACK 0). ALL THE ABOVE IN HALF-COLOUR RELIEF.

THE MARK CONSISTS OF THE FOLLOWING: THE

**CLASS 42—(Continued).**

WORDING "GEOSERVICES ISOTOPE LOGGING" APPEARING THE COLOR BLACK EXCEPT FOR THE SECOND LETTER "O" AND THE WORDING "ISOTOPE", WHICH APPEARS AS A SPHERE IN SHADES OF YELLOW AND GREEN AND FORMS PART OF THE DESIGN ELEMENT THAT APPEARS TO THE UPPER RIGHT OF THE WORDING AND IS COMPOSED OF THREE ADDITIONAL SPHERES IN SHADES OF YELLOW AND GREEN SURROUNDING A LARGER BLUE SPHERE IN WHICH THERE IS A SPHERE IN SHADES OF RED.

FOR DATA ANALYSIS, MATERIAL TESTING, TECHNICAL ADVICE IN THE FIELD OF GEOLOGY, GEOCHEMISTRY, DRILLING FOR AND EXPLOITATION OF HYDROCARBONS, TECHNICAL RESEARCH IN THE FIELD OF EVALUATING AND QUANTIFYING PETROLEUM, GAS AND DEPOSITS; TECHNICAL MONITORING AND INSPECTION OF WELLS, PETROLEUM AND DRILLING EQUIPMENT IN THE FIELD OF UNDERGROUND RESOURCES AND DEVELOPMENT IN THE NATURE OF ENERGY AND AQUIFEROUS RESOURCES; TECHNICAL PROJECT STUDIES, NAMELY, CARRYING OUT AND CONDUCTING TECHNICAL FEASIBILITY STUDIES INTO DRILLING FOR AND EXPLOITATION OF PETROLEUM, GAS AND OTHER ENERGETIC UNDERGROUND RESOURCES; COMPUTER PROGRAMMING; ENGINEERING AND RESEARCH IN EVALUATING AND QUANTIFYING PETROLEUM, GAS AND DEPOSITS; PETROLEUM AND DRILLING ENGINEERING; NON-BUSINESS PROFESSIONAL ADVICE AND PLANNING UNRELATED TO BUSINESS MANAGEMENT IN THE FIELD OF PETROLEUM DRILLING IN THE NATURE OF ANALYSIS, PROSPECTING, DRILLING, TESTING, MONITORING AND TRYING OUT OF PETROLEUM AND DRILLING EQUIPMENT IN THE FIELD OF UNDERGROUND RESOURCES DEVELOPMENT IN THE NATURE OF ENERGY AND AQUIFEROUS RESOURCES; RESEARCH IN PROSPECTING FOR, EXPLOITING AND ANALYZING ALL SUBSTANCES ON THE SURFACE AND UNDERGROUND, PARTICULARLY PETROLEUM, ROCKS, MINERALS AND NATURAL GAS; GEOLOGICAL AND GEOCHEMICAL MEASUREMENTS AND ANALYSES; EVALUATION AND ENGINEERING SERVICES IN THE FIELD OF GEOLOGY AND GEOCHEMISTRY; MEASUREMENTS AT OIL WELLS OR IN OTHER WELLS, NAMELY, EVALUATING AND QUANTIFYING PETROLEUM, GAS, AND OTHER ENERGETIC UNDERGROUND RESOURCES; DATA PROGRAMMING, NAMELY, WRITING OF DATA PROCESSING PROGRAMS (U.S. CLS. 100 AND 101).

SUZANNE BLANE, EXAMINING ATTORNEY

SN 85-006,219. EFFECTIVEUI, INC., DENVER, CO. FILED 4-5-2010.

## Ideate

THE MARK CONSISTS OF STANDARD CHARACTERS WITHOUT CLAIM TO ANY PARTICULAR FONT, STYLE, SIZE, OR COLOR.

FOR COMPUTER APPLICATION SOFTWARE FOR PORTABLE TABLET COMPUTERS, NAMELY, SOFTWARE FOR DIGITAL SKETCHING BY PROFESSIONAL DESIGNERS, MEDICAL PROFESSIONALS, TEACHERS OR COACHES (U.S. CLS. 100 AND 101).

FIRST USE 4-2-2010; IN COMMERCE 4-2-2010.

ANNE E. GUSTASON, EXAMINING ATTORNEY

**CLASS 42—(Continued).**

SN 85-007,734. ADOBE SYSTEMS INCORPORATED, SAN JOSE, CA. FILED 4-6-2010.

## CS LIVE

THE MARK CONSISTS OF STANDARD CHARACTERS WITHOUT CLAIM TO ANY PARTICULAR FONT, STYLE, SIZE, OR COLOR.

FOR COMPUTER SERVICES, NAMELY, PROVIDING TEMPORARY USE OF ON-LINE, NON-DOWNLOADABLE SOFTWARE FOR WORD PROCESSING, FOR CREATING, EDITING, LAYING OUT, PRINTING, ORGANIZING, MANAGING, SHARING AND ACCESS CONTROL OF DOCUMENTS, AND FOR COLLABORATIVE AUTHORING, EDITING AND REVIEWING OF MULTIMEDIA DOCUMENTS, TABLES, PRESENTATIONS, DESIGN PROJECTS, SCRIPTS AND SCREENPLAYS; PROVIDING TEMPORARY USE OF ON-LINE NON-DOWNLOADABLE SOFTWARE FOR USE IN CREATING, EDITING, ANNOTATING, VIEWING, SHARING, STORING AND DISTRIBUTING INTERACTIVE ELECTRONIC DOCUMENTS, NAMELY, PORTABLE DOCUMENT FORMAT (PDF) FILES; COMPUTER SERVICES, NAMELY, HOSTING ON-LINE WEB FACILITIES FOR OTHERS FOR ORGANIZING AND CONDUCTING ON-LINE, REAL-TIME MEETINGS, INTERACTIVE DISCUSSIONS AND PRESENTATIONS, FEATURING ELECTRONIC DATA SHARING, DOCUMENT SHARING, APPLICATION SHARING, COMPUTER SCREEN SHARING AND TEXT CHAT; PROVIDING TEMPORARY USE OF ON-LINE, NON-DOWNLOADABLE SOFTWARE FOR COLLABORATIVE SCREENWRITING AND STREAMLINING THE FLOW OF SCRIPT DATA INTO VIDEO PRODUCTIONS; PROVIDING TEMPORARY USE OF ON-LINE, NON-DOWNLOADABLE SOFTWARE FOR PREVIEWING AND TESTING WEB PAGES AND WEB PAGE CONTENT IN MULTIPLE WEB BROWSERS AND OPERATING SYSTEMS; COMPUTER AND WEBSITE DIAGNOSTIC SERVICES; PROVIDING ANALYTICS FOR OPTIMIZING DESIGN FOR WEB SITES AND MOBILE SCREENS; MANAGING AND OPTIMIZING WEBSITE PERFORMANCE (U.S. CLS. 100 AND 101).

FIRST USE 4-30-2010; IN COMMERCE 4-30-2010.

ALICIA COLLINS, EXAMINING ATTORNEY

SN 85-008,607. THOMSON REUTERS (SCIENTIFIC) INC., PHILADELPHIA, PA. FILED 4-7-2010.

## EUREKA!

THE MARK CONSISTS OF STANDARD CHARACTERS WITHOUT CLAIM TO ANY PARTICULAR FONT, STYLE, SIZE, OR COLOR.

FOR PROVIDING TEMPORARY USE OF NON-DOWNLOADABLE SOFTWARE FOR USE IN DATA MINING, AND SCIENTIFIC RESEARCH AND ANALYSIS IN THE FIELD OF MOLECULAR BIOLOGY, SYSTEMS BIOLOGY, CHEMOINFORMATICS AND BIOINFORMATICS; PROVIDING AN ON-LINE COMPUTER DATABASE IN THE FIELD OF MOLECULAR BIOLOGY, SYSTEMS BIOLOGY, CHEMOINFORMATICS AND BIOINFORMATICS (U.S. CLS. 100 AND 101).

FIRST USE 12-0-2009; IN COMMERCE 12-0-2009.

MIDGE BUTLER, EXAMINING ATTORNEY



**CLASS 42—(Continued).**

SN 85-016,206. LIGHTSQUARED LP, RESTON, VA. FILED 4-16-2010.

**CLASS 42—(Continued).**

SN 85-016,217. LIGHTSQUARED, LP, RESTON, VA. FILED 4-16-2010.



LIGHTSQUARED

THE MARK CONSISTS OF STYLIZED WORDING, "LIGHTSQUARED" IN ALL CAPS, WITH THE LETTER, "S" IN "SQUARED" THE LARGEST OF ALL THE LETTERING, WITH A DESIGN OF A SHADED BOX WITH UNSHADED LINES ON THE EDGES AND AN UNSHADED REFLECTIVE ORB ON THE CORNER OF THE BOX.

FOR RESEARCH SERVICES IN THE FIELD OF INFORMATION AND TELECOMMUNICATIONS TECHNOLOGY; COMPUTER PROGRAMMING SERVICES; PRODUCT RESEARCH, DESIGN AND DEVELOPMENT IN THE FIELD OF INFORMATION AND TELECOMMUNICATIONS TECHNOLOGY; TECHNICAL RESEARCH IN THE FIELD OF INFORMATION AND TELECOMMUNICATIONS TECHNOLOGY; RESEARCH, DESIGN AND DEVELOPMENT SERVICES RELATING TO COMPUTERS, COMPUTER PROGRAMS, COMPUTER SYSTEMS, COMPUTER SOFTWARE APPLICATION SOLUTIONS, DATA PROCESSING SYSTEMS, DATA MANAGEMENT, INFORMATION PROCESSING SYSTEMS, COMMUNICATIONS SERVICES, COMMUNICATIONS SOLUTIONS, COMMUNICATIONS SYSTEMS AND NETWORK INTERFACES; DESIGN OF COMPUTER HARDWARE; MAINTAIN, UPDATE AND DESIGN COMPUTER SOFTWARE AND COMPUTER PROGRAMS; COMPUTER PROGRAMMING SERVICES; TECHNICAL ADVICE AND CONSULTATION SERVICES IN THE FIELD OF INFORMATION TECHNOLOGY AND TELECOMMUNICATIONS; TECHNICAL SUPPORT SERVICES, NAMELY, TROUBLESHOOTING AND PROVIDING REMOTE AND LOCAL MONITORING, DIAGNOSTIC, REPAIR, AND UPGRADE ASSISTANCE FOR COMPUTER NETWORKS, TELECOMMUNICATIONS NETWORKS AND DATA TRANSMISSION NETWORKS; COMPUTER PROGRAMMING SERVICES TO CREATE ONLINE FACILITIES THAT WILL PROVIDE TELECOMMUNICATIONS SUPPORT; CREATING AND MAINTAINING DATABASES, INTRANETS AND WEB SITES; HOSTING THE WEB SITES OF OTHERS; INSTALLATION AND MAINTENANCE OF COMPUTER SOFTWARE; CREATING AND MAINTAINING WEB SITES AND WEB PAGES FOR OTHERS FEATURING TEXT, IMAGES AND MUSIC PROVIDED VIA COMPUTERS AND MOBILE TELEPHONES; WEATHER FORECASTING; WEATHER INFORMATION SERVICES; INTERIOR DESIGN SERVICES; PROVISION OF INTERNET SEARCH ENGINES (U.S. CLS. 100 AND 101).

ODESSA BIBBINS, EXAMINING ATTORNEY

THE MARK CONSISTS OF STANDARD CHARACTERS WITHOUT CLAIM TO ANY PARTICULAR FONT, STYLE, SIZE, OR COLOR.

FOR RESEARCH SERVICES IN THE FIELD OF INFORMATION AND TELECOMMUNICATIONS TECHNOLOGY; COMPUTER PROGRAMMING SERVICES; PRODUCT RESEARCH, DESIGN AND DEVELOPMENT IN THE FIELD OF INFORMATION AND TELECOMMUNICATIONS TECHNOLOGY; TECHNICAL RESEARCH IN THE FIELD OF INFORMATION AND TELECOMMUNICATIONS TECHNOLOGY; RESEARCH, DESIGN AND DEVELOPMENT SERVICES RELATING TO COMPUTERS, COMPUTER PROGRAMS, COMPUTER SYSTEMS, COMPUTER SOFTWARE APPLICATION SOLUTIONS, DATA PROCESSING SYSTEMS, DATA MANAGEMENT, INFORMATION PROCESSING SYSTEMS, COMMUNICATIONS SERVICES, COMMUNICATIONS SOLUTIONS, COMMUNICATIONS SYSTEMS AND NETWORK INTERFACES; DESIGN OF COMPUTER HARDWARE; MAINTAIN, UPDATE AND DESIGN COMPUTER SOFTWARE AND COMPUTER PROGRAMS; COMPUTER PROGRAMMING SERVICES; TECHNICAL ADVICE AND CONSULTATION SERVICES IN THE FIELD OF INFORMATION TECHNOLOGY AND TELECOMMUNICATIONS; TECHNICAL SUPPORT SERVICES, NAMELY, TROUBLESHOOTING AND PROVIDING REMOTE AND LOCAL MONITORING, DIAGNOSTIC, REPAIR, AND UPGRADE ASSISTANCE FOR COMPUTER NETWORKS, TELECOMMUNICATIONS NETWORKS AND DATA TRANSMISSION NETWORKS; COMPUTER PROGRAMMING SERVICES TO CREATE ONLINE FACILITIES THAT WILL PROVIDE TELECOMMUNICATIONS SUPPORT; CREATING AND MAINTAINING DATABASES, INTRANETS AND WEB SITES; HOSTING THE WEB SITES OF OTHERS; INSTALLATION AND MAINTENANCE OF COMPUTER SOFTWARE; CREATING AND MAINTAINING WEB SITES AND WEB PAGES FOR OTHERS FEATURING TEXT, IMAGES AND MUSIC PROVIDED VIA COMPUTERS AND MOBILE TELEPHONES; WEATHER FORECASTING; WEATHER INFORMATION SERVICES; INTERIOR DESIGN SERVICES; PROVISION OF INTERNET SEARCH ENGINES (U.S. CLS. 100 AND 101).

ODESSA BIBBINS, EXAMINING ATTORNEY

**CLASS 42—(Continued).**

SN 85-016,253. LIGHTSQUARED LP, RESTON, VA. FILED 4-16-2010.

OPPORTUNITY, MULTIPLIED

THE MARK CONSISTS OF STANDARD CHARACTERS WITHOUT CLAIM TO ANY PARTICULAR FONT, STYLE, SIZE, OR COLOR.

FOR RESEARCH SERVICES IN THE FIELD OF INFORMATION AND TELECOMMUNICATIONS TECHNOLOGY; COMPUTER PROGRAMMING SERVICES; PRODUCT RESEARCH, DESIGN AND DEVELOPMENT IN THE FIELD OF INFORMATION AND TELECOMMUNICATIONS TECHNOLOGY; TECHNICAL RESEARCH IN THE FIELD OF INFORMATION AND TELECOMMUNICATIONS TECHNOLOGY; RESEARCH, DESIGN AND DEVELOPMENT SERVICES RELATING TO COMPUTERS, COMPUTER PROGRAMS, COMPUTER SYSTEMS, COMPUTER SOFTWARE APPLICATION SOLUTIONS, DATA PROCESSING SYSTEMS, DATA MANAGEMENT, INFORMATION PROCESSING SYSTEMS, COMMUNICATIONS SERVICES, COMMUNICATIONS SOLUTIONS, COMMUNICATIONS SYSTEMS AND NETWORK INTERFACES; DESIGN OF COMPUTER HARDWARE; MAINTAIN, UPDATE AND DESIGN COMPUTER SOFTWARE AND COMPUTER PROGRAMS; COMPUTER PROGRAMMING SERVICES; TECHNICAL ADVICE AND CONSULTATION SERVICES IN THE FIELD OF INFORMATION TECHNOLOGY AND TELECOMMUNICATIONS; TECHNICAL SUPPORT SERVICES, NAMELY, TROUBLESHOOTING AND PROVIDING REMOTE AND LOCAL MONITORING, DIAGNOSTIC, REPAIR, AND UPGRADE ASSISTANCE FOR COMPUTER NETWORKS, TELECOMMUNICATIONS NETWORKS AND DATA TRANSMISSION NETWORKS; COMPUTER PROGRAMMING SERVICES TO CREATE ONLINE FACILITIES THAT WILL PROVIDE TELECOMMUNICATIONS SUPPORT; CREATING AND MAINTAINING DATABASES, INTRANETS AND WEB SITES; HOSTING THE WEB SITES OF OTHERS; INSTALLATION AND MAINTENANCE OF COMPUTER SOFTWARE; CREATING AND MAINTAINING WEB SITES AND WEB PAGES FOR OTHERS FEATURING TEXT, IMAGES AND MUSIC PROVIDED VIA COMPUTERS AND MOBILE TELEPHONES; WEATHER FORECASTING; WEATHER INFORMATION SERVICES; INTERIOR DESIGN SERVICES; PROVISION OF INTERNET SEARCH ENGINES (U.S. CLS. 100 AND 101).

ODESSA BIBBINS, EXAMINING ATTORNEY

**CLASS 42—(Continued).**

SN 85-018,081. TETHYS CORPORATION, COLCHESTER, VT. FILED 4-20-2010.



THE MARK CONSISTS OF CONCENTRIC CIRCLES ENCLOSING WAVES OF WATER SURROUNDING THE WORD ELEMENT "BLUE" WITH A WATER DROPLET SUSPENDED ABOVE THE WATER.

FOR PREVENTION OF POLLUTION SERVICES FOR OTHERS, NAMELY, EVALUATION OF REAL PROPERTY USE, AUDITING OF REAL PROPERTY USE, EVALUATION OF REAL PROPERTY DEVELOPMENT, AUDITING OF REAL PROPERTY DEVELOPMENT, EVALUATION OF REAL PROPERTY MAINTENANCE AND AUDITING OF REAL PROPERTY MAINTENANCE, ALL FOR THE PURPOSE OF REPORTING ON AND SUGGESTING METHODS, PROCESSES, SYSTEMS, TECHNIQUES AND PRODUCTS FOR OPTIMIZATION OF WATERSHED QUALITY (U.S. CLS. 100 AND 101).

FIRST USE 4-6-2010; IN COMMERCE 4-6-2010.  
NATALIE POLZER, EXAMINING ATTORNEY

---

SN 85-020,492. BIOPATH LABORATORIES, INC., OKLAHOMA CITY, OK. FILED 4-22-2010.

**ADVANCING PATHOLOGY**

THE MARK CONSISTS OF STANDARD CHARACTERS WITHOUT CLAIM TO ANY PARTICULAR FONT, STYLE, SIZE, OR COLOR.

NO CLAIM IS MADE TO THE EXCLUSIVE RIGHT TO USE "PATHOLOGY", APART FROM THE MARK AS SHOWN.

FOR DEVELOPING EQUIPMENT AND REAGENTS FOR MEDICAL LABORATORY USE, NAMELY, PRODUCT DEVELOPMENT FOR OTHERS AND DEVELOPMENT OF CHEMICAL REAGENTS FOR MEDICAL LABORATORY USE (U.S. CLS. 100 AND 101).

JAMES STEIN, EXAMINING ATTORNEY

**CLASS 42—(Continued).**

SN 85-021,147. ESPERANCE PHARMACEUTICALS, INC.,  
BATON ROUGE, LA. FILED 4-22-2010.

# CLYP

THE MARK CONSISTS OF STANDARD CHARACTERS  
WITHOUT CLAIM TO ANY PARTICULAR FONT, STYLE,  
SIZE, OR COLOR.

FOR PHARMACEUTICAL DRUG DEVELOPMENT  
SERVICES (U.S. CLS. 100 AND 101).  
FIRST USE 5-0-2009; IN COMMERCE 5-0-2009.  
DOUGLAS LEE, EXAMINING ATTORNEY

---

SN 85-021,290. ANGELA CAMACHO, DBA SPOTTED DOG  
GRAPHICS, SAN FRANCISCO, CA. FILED 4-22-2010.

## SPOTTED DOG GRAPHICS

THE MARK CONSISTS OF STANDARD CHARACTERS  
WITHOUT CLAIM TO ANY PARTICULAR FONT, STYLE,  
SIZE, OR COLOR.

NO CLAIM IS MADE TO THE EXCLUSIVE RIGHT TO  
USE "GRAPHICS", APART FROM THE MARK AS SHOWN.  
FOR GRAPHIC ART DESIGN; GRAPHIC ILLUSTRATION  
SERVICES FOR OTHERS; COMPUTER SERVICES,  
NAMELY, DESIGNING AND IMPLEMENTING WEB  
SITES FOR OTHERS (U.S. CLS. 100 AND 101).  
FIRST USE 7-13-1992; IN COMMERCE 7-13-1992.  
PRISCILLA MILTON, EXAMINING ATTORNEY

---

SN 85-021,491. WAY, DAVID, MARS HILL, NC. FILED 4-23-  
2010.

# ROOST

THE MARK CONSISTS OF STANDARD CHARACTERS  
WITHOUT CLAIM TO ANY PARTICULAR FONT, STYLE,  
SIZE, OR COLOR.

FOR BUILDING SERVICES, NAMELY, INTERIOR  
DESIGN AND ARCHITECTURAL DESIGN (U.S. CLS.  
100 AND 101).  
FIRST USE 11-1-2007; IN COMMERCE 11-1-2007.  
MARY CRAWFORD, EXAMINING ATTORNEY

**CLASS 42—(Continued).**

SN 85-025,087. SAFFRON TECHNOLOGY, INC., CARY, NC.  
FILED 4-28-2010.

# SAFFRONSIERRA

THE MARK CONSISTS OF STANDARD CHARACTERS  
WITHOUT CLAIM TO ANY PARTICULAR FONT, STYLE,  
SIZE, OR COLOR.

OWNER OF U.S. REG. NOS. 2,870,776, 3,018,865 AND  
3,731,030.

FOR PLATFORM AS A SERVICE FEATURING COM-  
PUTER SOFTWARE PLATFORMS USING AN ASSOCIA-  
TIVE MEMORY MODEL FOR STORING, CREATING,  
MANAGING, FILTERING AND ANALYZING DATA  
FROM A WIDE VARIETY OF SOURCES, DATA BASES  
AND FILES AND OF MULTIPLE DATA TYPES FOR  
PATTERN RECOGNITION, DATA MINING, ANALYSIS  
AND DISCOVERY OF ASSOCIATED AND LINKED  
ENTITIES AND DATA POINTS FOR USE IN GOVERN-  
MENT AND COMMERCIAL FIELDS (U.S. CLS. 100 AND  
101).

FIRST USE 2-14-2010; IN COMMERCE 2-14-2010.  
MARK SPARACINO, EXAMINING ATTORNEY

---

SN 85-029,705. ELEVATE HR INC., PARSIPPANY, NJ. FILED  
5-4-2010.



NO CLAIM IS MADE TO THE EXCLUSIVE RIGHT TO  
USE "HR" OR "INC.", APART FROM THE MARK AS  
SHOWN.

THE COLOR(S) GREEN, ORANGE, BROWN AND WHITE  
IS/ARE CLAIMED AS A FEATURE OF THE MARK.

THE MARK CONSISTS OF THE TERMS, "HR INC." IN  
BROWN, ABOVE AND TO THE RIGHT OF THE WORD,  
"ELEVATE" IN GREEN, WITH THE LETTER "V" IN  
ORANGE WITH THE RIGHT SIDE ARCHING UP TO A  
POINT AND DOWN TO FORM THE LEFT SIDE OF THE "H"  
OF "HR", AND INTEGRATED WITH THE DESIGN OF  
BROWN MOUNTAINS WITH WHITE SNOW, ABOVE THE  
WORDS, "TAKING TALENT TO THE TOP" IN BROWN.

FOR BUSINESS TECHNOLOGY SOFTWARE CONSULT-  
TATION SERVICES; COMPUTER SOFTWARE CONSULT-  
TANCY; COMPUTER SOFTWARE CONSULTATION;  
COMPUTER SOFTWARE DEVELOPMENT; SOFTWARE  
AUTHORING; SOFTWARE DESIGN AND DEVELOP-  
MENT (U.S. CLS. 100 AND 101).

FIRST USE 12-8-2009; IN COMMERCE 12-8-2009.  
BARBARA A. GOLD, EXAMINING ATTORNEY

**CLASS 42—(Continued).**

SN 85-033,016. FASHION WORLD, INC., DBA BIJAN, BEVERLY HILLS, CA. FILED 5-7-2010.



OWNER OF U.S. REG. NOS. 1,156,083 AND 1,160,600.  
THE NAME "BIJAN" IDENTIFIES A LIVING INDIVIDUAL WHOSE CONSENT IS OF RECORD.  
THE MARK CONSISTS OF THE WORDING "BIJAN" IN STYLIZED FONT.  
FOR DESIGN FOR OTHERS IN THE FIELD OF CLOTHING; PLANNING AND LAYOUT DESIGN FOR THE INTERIOR SPACE OF RETAIL BUSINESS ESTABLISHMENTS (U.S. CLS. 100 AND 101).  
FIRST USE 6-1-1983; IN COMMERCE 6-1-1983.  
TOBY BULLOFF, EXAMINING ATTORNEY

**CLASS 42—(Continued).**

SN 85-034,630. MERIDIAN MEDICAL SYSTEMS LLC, CAPE HAZE, FL. FILED 5-10-2010.



THE MARK CONSISTS OF STANDARD CHARACTERS WITHOUT CLAIM TO ANY PARTICULAR FONT, STYLE, SIZE, OR COLOR.

FOR REMOTE DIAGNOSTIC AND MONITORING SERVICES FOR MEDICAL IMAGING EQUIPMENT IN HOSPITALS, NAMELY ULTRASOUND SYSTEMS, COMPUTED TOMOGRAPHY (CT) SYSTEMS, MAGNETIC RESONNANCE IMAGING (MRI) SYSTEMS, DIGITAL MAMMOGRAPHY SYSTEMS, DIGITAL VASCULAR AND CATH LAB X-RAY SYSTEMS, DIGITAL X-RAY SYSTEMS, NUCLEAR MEDECINE SYSTEMS AND POSITRON EMISSION TOMOGRAPHY (PET) AND PET/CT SYSTEMS (U.S. CLS. 100 AND 101).

INGA ERVIN, EXAMINING ATTORNEY

SN 85-033,549. THE INTERIOR BOUTIQUE, LLC, TEMPLE HILLS, MD. FILED 5-7-2010.



NO CLAIM IS MADE TO THE EXCLUSIVE RIGHT TO USE "THE INTERIOR BOUTIQUE, LLC", APART FROM THE MARK AS SHOWN.

THE MARK CONSISTS OF THE TEXT "THE INTERIOR BOUTIQUE, LLC" STYLIZED WITH A LAMP BEING USED AS THE SECOND "I" IN THE WORD "INTERIOR".

FOR DESIGN OF INTERIOR DECOR; INTERIOR DESIGN SERVICES (U.S. CLS. 100 AND 101).

LESLIE RICHARDS, EXAMINING ATTORNEY

SN 85-042,607. ALBERTA 2ND CALL SECONDARY UNDERGROUND LOCATING SERVICES LTD., VEGREVILLE, ALBERTA, CANADA, FILED 5-19-2010.



THE MARK CONSISTS OF STANDARD CHARACTERS WITHOUT CLAIM TO ANY PARTICULAR FONT, STYLE, SIZE, OR COLOR.

PRIORITY CLAIMED UNDER SEC. 44(D) ON CANADA APPLICATION NO. 1463645, FILED 12-21-2009, REG. NO. TMA786146, DATED 12-30-2010, EXPIRES 12-30-2025.

FOR LAND SURVEYING SERVICES; LOCATING OF UNDERGROUND UTILITY PIPELINES, CABLES AND WIRES (U.S. CLS. 100 AND 101).

CHARLES L. JENKINS, EXAMINING ATTORNEY

**CLASS 42—(Continued).**

SN 85-048,806. TOSS CORPORATION, FRAMINGHAM, MA.  
FILED 5-26-2010.



NO CLAIM IS MADE TO THE EXCLUSIVE RIGHT TO USE "CLOUD", APART FROM THE MARK AS SHOWN.

THE STIPPLING IS FOR SHADING PURPOSES ONLY.

THE MARK CONSISTS OF THE WORDING "VBCDR" IN STYLIZED FONT ABOVE THE WORDING "CLOUD" APPEARING WITHIN A RECTANGLE.

FOR APPLICATION SERVICE PROVIDER (ASP), NAMELY, HOSTING COMPUTER SOFTWARE APPLICATIONS OF OTHERS; APPLICATION SERVICE PROVIDER FEATURING APPLICATION PROGRAMMING INTERFACE (API) SOFTWARE FOR ALLOWING DATA RETRIEVAL, UPLOAD, ACCESS AND MANAGEMENT; APPLICATION SERVICE PROVIDER, NAMELY, PROVIDING, HOSTING, MANAGING, DEVELOPING, AND MAINTAINING APPLICATIONS, SOFTWARE, WEB SITES, AND DATABASES IN THE FIELDS OF PERSONAL PRODUCTIVITY, WIRELESS COMMUNICATION, MOBILE INFORMATION ACCESS, AND REMOTE DATA MANAGEMENT FOR WIRELESS DELIVERY OF CONTENT TO HANDHELD COMPUTERS, LAPTOPS AND MOBILE ELECTRONIC DEVICES; BACK-UP SERVICES FOR COMPUTER HARD DRIVE DATA; BUSINESS TECHNOLOGY SOFTWARE CONSULTATION SERVICES; CLOUD COMPUTING FEATURING SOFTWARE FOR USE IN HOSTING COMPUTER SOFTWARE APPLICATIONS; COMPUTER CONSULTATION; COMPUTER CONSULTATION IN THE FIELD OF COMPUTER SECURITY; COMPUTER DIAGNOSTIC SERVICES; COMPUTER DISASTER RECOVERY PLANNING; COMPUTER FORENSIC SERVICES; COMPUTER HARDWARE AND SOFTWARE CONSULTING SERVICES; COMPUTER HARDWARE AND SOFTWARE DESIGN; COMPUTER HARDWARE DEVELOPMENT; COMPUTER MONITORING SERVICE WHICH TRACKS APPLICATION SOFTWARE PERFORMANCE, PERFORMS PERIODIC MAINTENANCE AND PROVIDES REPORTS AND ALERTS CONCERNING SUCH PERFORMANCE; COMPUTER MONITORING SERVICE WHICH TRACKS HARDWARE PERFORMANCE AND PROCESSES AND SENDS OUT HISTORICAL REPORTS AND ALERTS; COMPUTER NETWORK DESIGN FOR OTHERS; COMPUTER PROGRAMMING AND COMPUTER SYSTEM ANALYSIS; COMPUTER PROGRAMMING AND MAINTENANCE OF COMPUTER PROGRAMS; COMPUTER PROGRAMMING AND SOFTWARE DESIGN; COMPUTER PROGRAMMING CONSULTANCY; COMPUTER PROGRAMMING FOR OTHERS; COMPUTER PROGRAMMING SERVICES; COMPUTER SECURITY CONSULTANCY; COMPUTER SECURITY CONSULTANCY IN THE FIELD OF SCANNING AND PENETRATION TESTING OF COMPUTERS AND NETWORKS TO ASSESS INFORMATION SECURITY VULNERABILITY; COMPUTER SECURITY SERVICE, NAMELY, HARD DRIVE ERASURE; COMPUTER SECURITY SERVICE, NAMELY, RESTRICTING ACCESS TO AND BY COMPUTER NETWORKS TO AND OF UNDESIRE WEB SITES, MEDIA AND INDIVIDUALS AND FACILITIES; COMPUTER SERVICE, ACTING AS AN APPLICATION SERVICE PROVIDER IN THE FIELD OF KNOWLEDGE MANAGEMENT TO HOST COMPUTER APPLICATION SOFTWARE FOR CREATING SEARCHABLE DATABASES OF INFORMATION AND DATA TO ALLOW USERS TO PERFORM, ON-LINE, THE COLLECTING AND ANALYZING OF DIFFERENT TYPES OF OPINION SURVEYS; COMPUTER SERVICE, NAMELY, ACTING AS AN APPLICATION SERVICE PROVIDER IN THE FIELD OF KNOWLEDGE MANAGEMENT TO HOST COMPUTER APPLICATION SOFTWARE FOR SEARCH-

**CLASS 42—(Continued).**

ING AND RETRIEVING INFORMATION FROM DATABASES AND COMPUTER NETWORKS; COMPUTER SERVICE, NAMELY, ACTING AS AN APPLICATION SERVICE PROVIDER IN THE FIELD OF KNOWLEDGE MANAGEMENT TO HOST COMPUTER APPLICATION SOFTWARE FOR THE COLLECTION, EDITING, ORGANIZING, MODIFYING, BOOK MARKING, TRANSMISSION, STORAGE AND SHARING OF DATA AND INFORMATION; COMPUTER SERVICES, NAMELY, COMPUTER SYSTEM ADMINISTRATION FOR OTHERS; COMPUTER SERVICES, NAMELY, CREATING, MAINTAINING, DESIGNING AND IMPLEMENTING WEB SITES FOR OTHERS AND HOSTING THE WEB SITE OF OTHERS ON A COMPUTER SERVER FOR A GLOBAL COMPUTER NETWORK; COMPUTER SERVICES, NAMELY, DATA RECOVERY SERVICES; COMPUTER SERVICES, NAMELY, DESIGNING AND IMPLEMENTING NETWORK WEB PAGES FOR OTHERS; COMPUTER SERVICES, NAMELY, DESIGNING AND IMPLEMENTING WEB SITES FOR OTHERS; COMPUTER SERVICES, NAMELY, FILTERING OF UNWANTED E-MAILS; COMPUTER SERVICES, NAMELY, HOSTING AN INTERACTIVE WEB SITE THAT ALLOWS USERS TO UPLOAD, STORE AND MAINTAIN AUTOMOTIVE REPAIR RECORDS, MANAGE ONLINE RECORDS OF SERVICES PERFORMED ON THEIR VEHICLES, AND RECEIVE AUTOMATED SERVICE REMINDERS, SAFETY ALERTS, RECALL ALERTS, AND SPECIAL DISCOUNT OFFERS; COMPUTER SERVICES, NAMELY, HOSTING OF INSPECTION, TESTING, AND QUALITY CONTROL SERVICES' DIGITAL CONTENT OF OTHERS; COMPUTER SERVICES, NAMELY, MONITORING, TESTING, ANALYZING, AND REPORTING ON THE INTERNET TRAFFIC CONTROL AND CONTENT CONTROL OF THE WEB SITES OF OTHERS; COMPUTER SERVICES, NAMELY, ONLINE SCANNING, DETECTING, QUARANTINING AND ELIMINATING VIRUSES, WORMS, TROJANS, SPYWARE, ADWARE, MALWARE AND UNAUTHORIZED DATA AND PROGRAMS ON COMPUTERS AND ELECTRONIC DEVICES; COMPUTER SERVICES, NAMELY, PROVIDING A WEB-BASED SYSTEM AND ONLINE PORTAL FOR CUSTOMERS TO REMOTELY MANAGE, ADMINISTER, MODIFY AND CONTROL THEIR END USER COMPUTER DEVICES, DATA AND SOFTWARE APPLICATIONS; COMPUTER SERVICES, NAMELY, PROVIDING AN INTERACTIVE WEB SITE THAT ALLOWS USERS TO COLLECT, STORE, MANAGE, DELIVER AND SHOWCASE ELECTRONIC AND PAPER-BASED CONTENT; COMPUTER SERVICES, NAMELY, PROVIDING SEARCH ENGINES FOR OBTAINING DATA FROM JOURNALS AND OTHER PUBLICATIONS ON A GLOBAL COMPUTER NETWORK; COMPUTER SERVICES, NAMELY, PROVIDING SEARCH ENGINES FOR OBTAINING DATA ON A GLOBAL COMPUTER NETWORK; COMPUTER SERVICES, NAMELY, REMOTE AND ON-SITE MANAGEMENT OF CLOUD COMPUTING SYSTEMS AND APPLICATIONS FOR OTHERS; COMPUTER SERVICES, NAMELY, REMOTE AND ON-SITE MANAGEMENT OF THE INFORMATION TECHNOLOGY (IT) CLOUD COMPUTING SYSTEMS OF OTHERS; COMPUTER SERVICES, NAMELY, REMOTE AND ON-SITE MANAGEMENT OF THE INFORMATION TECHNOLOGY (IT) SYSTEMS OF OTHERS; COMPUTER SERVICES, NAMELY, REMOTE MANAGEMENT OF COMPUTER APPLICATIONS FOR OTHERS; COMPUTER SERVICES, NAMELY, SEARCH ENGINE OPTIMIZATION; COMPUTER SERVICES, NAMELY, THE REDIRECTION AND FORWARDING OF MESSAGES; COMPUTER SITE DESIGN; COMPUTER SOFTWARE CONSULTANCY; COMPUTER SOFTWARE CONSULTATION; COMPUTER SOFTWARE CONSULTING; COMPUTER SOFTWARE DESIGN; COMPUTER SOFTWARE DESIGN AND UPDATING; COMPUTER SOFTWARE DESIGN FOR OTHERS; COMPUTER SOFTWARE DESIGN, COMPUTER PROGRAMMING, OR MAINTENANCE OF COMPUTER SOFTWARE; COMPUTER SOFTWARE DEVELOPMENT; COMPUTER SOFTWARE INSTALLATION AND MAINTENANCE; COMPUTER SYSTEMS ANALYSIS; COMPUTER SYSTEMS INTEGRATION SERVICES; COMPUTER TECHNICAL SUPPORT SERVICES, NAMELY, 24/7 SERVICE DESK/HELP DESK SERVICES FOR IT INFRASTRUCTURE, OPERATING SYSTEMS, DATABASE SYSTEMS, AND WEB APPLICATIONS.; COMPUTER TECHNOLOGY SUPPORT SERVICES, NAMELY, HELP DESK SERVICES; COMPUTER VIRUS PROTECTION SERVICES; COMPUTER-AIDED

**CLASS 42—(Continued).**

ENGINEERING SERVICES FOR OTHERS; CONSULTANCY IN THE FIELD OF SOFTWARE DESIGN; CONSULTATION SERVICES IN THE FIELD OF SEARCH ENGINE OPTIMIZATION; CONSULTATION SERVICES IN THE FIELDS OF SELECTION, IMPLEMENTATION AND USE OF COMPUTER HARDWARE AND SOFTWARE SYSTEMS FOR OTHERS; CONSULTING IN THE FIELD OF CONFIGURATION MANAGEMENT FOR COMPUTER HARDWARE AND SOFTWARE; CONSULTING IN THE FIELD OF INFORMATION TECHNOLOGY; CONSULTING IN THE FIELD OF IT PROJECT MANAGEMENT; CONSULTING IN THE FIELD OF TELECOMMUNICATIONS TECHNOLOGY; CONSULTING IN THE FIELD OF VIRTUALIZATION TECHNOLOGIES FOR ENTERPRISES AND BUSINESSES; CONSULTING SERVICES IN THE FIELD OF CLOUD COMPUTING; CONSULTING SERVICES IN THE FIELD OF COMPUTER-BASED INFORMATION SYSTEMS FOR BUSINESSES; CONSULTING SERVICES IN THE FIELD OF DESIGN, SELECTION, IMPLEMENTATION AND USE OF COMPUTER HARDWARE AND SOFTWARE SYSTEMS FOR OTHERS; CONSULTING SERVICES IN THE FIELD OF HOSTING COMPUTER SOFTWARE APPLICATIONS; CONSULTING SERVICES IN THE FIELD OF SOFTWARE AS A SERVICE (SAAS); CONVERSION OF DATA OR DOCUMENTS FROM PHYSICAL TO ELECTRONIC MEDIA; CREATING, MAINTAINING, AND MODERNIZING COMPUTER SOFTWARE; CUSTOMIZATION OF COMPUTER HARDWARE AND SOFTWARE; CUSTOMIZED SOFTWARE DEVELOPMENT SERVICES; DATA CONVERSION OF ELECTRONIC INFORMATION; DATA ENCRYPTION AND DECODING SERVICES; DATA ENCRYPTION SERVICES; DATA MIGRATION SERVICES; DATA MINING; DATA WAREHOUSING; DEBUGGING COMPUTER SOFTWARE FOR OTHERS; DESIGN AND DEVELOPMENT OF COMPUTER HARDWARE; DESIGN AND DEVELOPMENT OF COMPUTER HARDWARE AND SOFTWARE; DESIGN AND DEVELOPMENT OF COMPUTER SOFTWARE; DESIGN AND DEVELOPMENT OF NETWORKS; DESIGN AND DEVELOPMENT OF ON-LINE COMPUTER SOFTWARE SYSTEMS; DESIGN AND DEVELOPMENT OF WIRELESS COMPUTER NETWORKS; DESIGN AND WRITING OF COMPUTER SOFTWARE; DESIGN OF COMPUTER HARDWARE, INTEGRATED CIRCUITS, COMMUNICATIONS HARDWARE AND SOFTWARE AND COMPUTER NETWORKS FOR OTHERS; DESIGN, DEPLOYMENT AND MANAGEMENT OF WIRELESS NETWORKS FOR OTHERS; DESIGN, DEVELOPMENT AND CONSULTING SERVICES IN THE FIELD OF SOFTWARE FOR CONTENT MANAGEMENT; DESIGN, DEVELOPMENT AND IMPLEMENTATION OF SOFTWARE; DESIGN, DEVELOPMENT, AND CONSULTING SERVICES IN THE FIELD OF HOME AND WORKPLACE AUTOMATION HARDWARE AND SOFTWARE; DESIGN, DEVELOPMENT, INSTALLATION AND MAINTENANCE OF COMPUTER SOFTWARE; DESIGN, INSTALLATION, UPDATING AND MAINTENANCE OF COMPUTER SOFTWARE; DESIGN, MAINTENANCE, DEVELOPMENT AND UPDATING OF COMPUTER SOFTWARE; DEVELOPING AND UPDATING COMPUTER SOFTWARE; DEVELOPING COMPUTER SOFTWARE; DEVELOPMENT AND IMPLEMENTATION OF SOFTWARE, HARDWARE AND TECHNOLOGY SOLUTIONS FOR THE PURPOSE OF PRODUCTIZATION OF ELECTRONIC COMPONENTS AND ELECTRONIC SYSTEMS; DEVELOPMENT OF SECURITY SYSTEMS AND CONTINGENCY PLANNING FOR INFORMATION SYSTEMS; DEVELOPMENT OF SOFTWARE FOR SECURE NETWORK OPERATIONS; DEVELOPMENT, UPDATING AND MAINTENANCE OF SOFTWARE AND DATA BASES; INFORMATION TECHNOLOGY CONSULTATION; INSTALLATION AND MAINTENANCE OF COMPUTER SOFTWARE; INSTALLATION AND MAINTENANCE OF INTERNET ACCESS SOFTWARE; INSTALLATION AND REPAIR OF COMPUTER SOFTWARE, INCLUDING MOBILE PERFORMANCE OF SUCH SERVICES ON CUSTOMER PREMISES; INSTALLATION OF COMPUTER SOFTWARE; INSTALLATION, MAINTENANCE AND REPAIR OF COMPUTER SOFTWARE; INSTALLATION, MAINTENANCE AND REPAIR OF SOFTWARE FOR COMPUTER SYSTEMS; INSTALLATION, REPAIR AND MAINTENANCE OF COMPUTER SOFTWARE; INSTALLING COMPUTER PROGRAMS; INTEGRATION OF COMPUTER SYSTEMS AND NETWORKS; IT CONSULTING SERVICES; IT INTEGRATION SERVICES; MAINTENANCE AND UP-

**CLASS 42—(Continued).**

DATING OF COMPUTER SOFTWARE; MAINTENANCE AND UPGRADING OF COMPUTER SOFTWARE; MAINTENANCE OF COMPUTER SOFTWARE; MAINTENANCE OF COMPUTER SOFTWARE RELATING TO COMPUTER SECURITY AND PREVENTION OF COMPUTER RISKS; MAINTENANCE OF SOFTWARE FOR INTERNET ACCESS; RENTING COMPUTER SOFTWARE; RENTING OUT HARDWARE AND SOFTWARE; REPAIR OF COMPUTER SOFTWARE; REPAIR OF DAMAGED COMPUTER PROGRAMS; REPAIR OF SOFTWARE; RESEARCH AND DEVELOPMENT OF COMPUTER SOFTWARE; RESEARCH, DEVELOPMENT, DESIGN AND UPGRADING OF COMPUTER SOFTWARE; SOFTWARE AUTHORING; SOFTWARE DESIGN AND DEVELOPMENT; SOFTWARE DEVELOPMENT FOR OTHERS IN THE FIELD OF SOFTWARE CONFIGURATION MANAGEMENT; TECHNICAL SUPPORT SERVICES, NAMELY, INSTALLATION, ADMINISTRATION, AND TROUBLESHOOTING OF WEB AND DATABASE APPLICATIONS; TECHNICAL SUPPORT SERVICES, NAMELY, REMOTE ADMINISTRATION AND MANAGEMENT OF IN-HOUSE AND HOSTED DATACENTER DEVICES, DATABASES AND SOFTWARE APPLICATIONS; TECHNICAL SUPPORT SERVICES, NAMELY, REMOTE AND ON-SITE INFRASTRUCTURE MANAGEMENT SERVICES FOR MONITORING, ADMINISTRATION AND MANAGEMENT OF PUBLIC AND PRIVATE CLOUD COMPUTING IT AND APPLICATION SYSTEMS; TECHNICAL SUPPORT SERVICES, NAMELY, TECHNICAL ADMINISTRATION OF SERVERS FOR OTHERS AND TROUBLESHOOTING IN THE NATURE OF DIAGNOSING SERVER PROBLEMS; TECHNICAL SUPPORT SERVICES, NAMELY, TROUBLESHOOTING IN THE NATURE OF DIAGNOSING COMPUTER HARDWARE AND SOFTWARE PROBLEMS; TECHNICAL SUPPORT SERVICES, NAMELY, TROUBLESHOOTING OF COMPUTER SOFTWARE PROBLEMS; TECHNICAL SUPPORT SERVICES, NAMELY, TROUBLESHOOTING OF INDUSTRIAL PROCESS CONTROL COMPUTER SOFTWARE PROBLEMS; TECHNICAL SUPPORT, NAMELY, MONITORING OF NETWORK SYSTEMS; TECHNICAL SUPPORT, NAMELY, PROVIDING BACK-UP COMPUTER PROGRAMS AND FACILITIES; UP-DATING OF COMPUTER SOFTWARE; UPDATE OF COMPUTER SOFTWARE; UPDATING AND DESIGN OF COMPUTER SOFTWARE; UPDATING AND MAINTENANCE OF COMPUTER SOFTWARE; UPDATING AND RENTAL OF SOFTWARE FOR DATA PROCESSING; UPDATING OF COMPUTER PROGRAMS FOR THIRD PARTIES; UPDATING OF COMPUTER SOFTWARE FOR OTHERS; UPDATING OF COMPUTER SOFTWARE RELATING TO COMPUTER SECURITY AND PREVENTION OF COMPUTER RISKS (U.S. CLS. 100 AND 101).  
EMILY CHUO, EXAMINING ATTORNEY

SN 85-049,293. BRISTOL-MYERS SQUIBB COMPANY, NEW YORK, NY. FILED 5-27-2010.

## D- Lite - Direct Acting Antivirals Lambda Interferon Treatment Evaluation

THE MARK CONSISTS OF STANDARD CHARACTERS WITHOUT CLAIM TO ANY PARTICULAR FONT, STYLE, SIZE, OR COLOR.

NO CLAIM IS MADE TO THE EXCLUSIVE RIGHT TO USE "DIRECT ACTING ANTIVIRALS LAMBDA INTERFERON TREATMENT EVALUATION", APART FROM THE MARK AS SHOWN.

FOR MEDICAL AND SCIENTIFIC RESEARCH, NAMELY, CONDUCTING CLINICAL TRIALS RELATING TO PHARMACEUTICAL PREPARATIONS FOR HUMAN USE (U.S. CLS. 100 AND 101).

MAUREEN DALL, EXAMINING ATTORNEY

**CLASS 42—(Continued).**

SN 85-062,286. KRISTIANNE WATTS, DBA KW DESIGNS, SOLANA BEACH, CA. FILED 6-14-2010.

kw designs

THE MARK CONSISTS OF STANDARD CHARACTERS WITHOUT CLAIM TO ANY PARTICULAR FONT, STYLE, SIZE, OR COLOR.

NO CLAIM IS MADE TO THE EXCLUSIVE RIGHT TO USE "DESIGNS", APART FROM THE MARK AS SHOWN.

FOR INTERIOR DESIGN SERVICES (U.S. CLS. 100 AND 101).

FIRST USE 4-12-2006; IN COMMERCE 4-12-2006.  
JANICE KIM, EXAMINING ATTORNEY

---

SN 85-064,513. RAINCLOUD MEDIA LLC, SOUTHLAKE, TX. FILED 6-16-2010.

 BURST

THE MARK CONSISTS OF THE STYLIZED LETTER "B" IN A BOX WITH ROUNDED CORNERS NEXT TO THE WORD "BURST"

FOR SOFTWARE AS A SERVICE (SAAS) SERVICES FEATURING SOFTWARE IN THE FIELD OF SOCIAL MEDIA (U.S. CLS. 100 AND 101).

FIRST USE 6-10-2010; IN COMMERCE 6-10-2010.  
SANI KHOURI, EXAMINING ATTORNEY

---

SN 85-065,326. FEDERAL HOME LOAN MORTGAGE CORPORATION, MCLEAN, VA. FILED 6-17-2010.

UMDP

THE MARK CONSISTS OF STANDARD CHARACTERS WITHOUT CLAIM TO ANY PARTICULAR FONT, STYLE, SIZE, OR COLOR.

FOR DEVELOPMENT OF STANDARDS FOR UNIFORM RESIDENTIAL APPRAISAL AND MORTGAGE LOAN DELIVERY DATA IN THE FINANCIAL AND REAL ESTATE SERVICES INDUSTRY (U.S. CLS. 100 AND 101).

BARBARA RUTLAND, EXAMINING ATTORNEY

**CLASS 42—(Continued).**

SN 85-065,604. RENOVO CORPORATION, NAPLES, FL. FILED 6-17-2010.

 Renovo  
Financial Intelligence by design

NO CLAIM IS MADE TO THE EXCLUSIVE RIGHT TO USE "FINANCIAL INTELLIGENCE", APART FROM THE MARK AS SHOWN.

THE COLOR(S) BLACK AND BLUE IS/ARE CLAIMED AS A FEATURE OF THE MARK.

THE MARK CONSISTS OF STYLIZED LETTERS "RENOVO FINANCIAL INTELLIGENCE BY DESIGN", ALL BLACK LETTERS EXCEPT THE "R" IN "RENOVO" IS BLUE ALONG WITH A BLUE UNDERLINE OF THE WORD "RENOVO".

FOR CLOUD COMPUTING PROVIDED VIA A WEBSITE FEATURING SOFTWARE FOR USE BY BUSINESSES IN PERFORMING BUSINESS MANAGEMENT FUNCTIONS, NAMELY, FINANCIAL ACCOUNT MANAGEMENT, FINANCIAL REPORTING, ACCOUNTING AND FINANCIAL ANALYSIS OF FINANCIAL TRANSACTION DATA (U.S. CLS. 100 AND 101).

FIRST USE 4-1-2010; IN COMMERCE 4-1-2010.  
ELISSA GARBER KON, EXAMINING ATTORNEY

---

SN 85-065,630. EHEALTH WORKFLOW ANALYTICS, LLC, WALNUT CREEK, CA. FILED 6-17-2010.

 eHealthWorkflow  
Analytics, LLC

NO CLAIM IS MADE TO THE EXCLUSIVE RIGHT TO USE "EHEALTH WORKFLOW ANALYTICS, LLC", APART FROM THE MARK AS SHOWN.

THE COLOR(S) BLACK AND RED IS/ARE CLAIMED AS A FEATURE OF THE MARK.

THE MARK CONSISTS OF A STYLIZED BLACK AND RED DESIGN, SURROUNDED BY A BLACK HALF MOON, TO THE LEFT OF THE RED LETTER "E" FOLLOWED BY THE BLACK WORD "HEALTH" NEXT TO THE RED WORD "WORKFLOW", ABOVE THE RED WORDS "ANALYTICS, LLC".

FOR HEALTHCARE INFORMATION TECHNOLOGY CONSULTING SERVICES (U.S. CLS. 100 AND 101).  
FIRST USE 6-14-2010; IN COMMERCE 6-14-2010.  
ELIZABETH KAJUBI, EXAMINING ATTORNEY

**CLASS 42—(Continued).**

SN 85-065,724. PREDICTIVE PROFILES INCORPORATED, BLOOMINGTON, MN. FILED 6-17-2010.

iSelect

THE MARK CONSISTS OF STANDARD CHARACTERS WITHOUT CLAIM TO ANY PARTICULAR FONT, STYLE, SIZE, OR COLOR.

FOR PROVIDING TEMPORARY USE OF ON-LINE NONDOWNLOADABLE SOFTWARE AND APPLICATIONS ENABLING EMPLOYERS TO SCREEN JOB APPLICANTS, NAMELY, CANDIDATE ANALYSIS, RANKING AND REPORTING, AND LIKELIHOOD OF CANDIDATE SUCCESS, AND WHICH ALSO ENABLES JOB APPLICANTS TO APPLY FOR POSITIONS ONLINE (U.S. CLS. 100 AND 101).

FIRST USE 2-1-2002; IN COMMERCE 2-1-2002.  
ANNE FARRELL, EXAMINING ATTORNEY

**CLASS 42—(Continued).**

SN 85-081,155. BLUCAPP, INC., SEATTLE, WA. FILED 7-9-2010.



THE COLOR(S) WHITE, YELLOW, LIGHT GREEN, LIGHT SKY BLUE AND NIGHT BLUE IS/ARE CLAIMED AS A FEATURE OF THE MARK.

THE MARK CONSISTS OF CURSIVE FONT FOR THE WORD "SCRUBLY" SHADED IN WHITE AND LIGHT SKY BLUE COLOR WITH A NIGHT BLUE COLOR BACKGROUND. FROM THE BASE OF THE LETTERS "S" AND "C" ORIGINATES RECTANGULAR CURVED DESIGN ELEMENTS IN SHADES OF LIGHT GREEN AND YELLOW COLOR; ENDING WITH DISSIMILAR BUBBLES/CIRCLES IN THE BACKGROUND SHADED IN LIGHT SKY BLUE AND WHITE COLOR.

FOR PROVIDING A WEBSITE FEATURING RESOURCES, NAMELY, NON-DOWNLOADABLE SOFTWARE FOR THE MANAGEMENT OF ADDRESS BOOK(S) OF ELECTRONIC MAILS; SPECIFICALLY, TO AUTOMATICALLY REMOVE DUPLICATE CONTACTS FROM ADDRESS BOOKS (U.S. CLS. 100 AND 101).

FIRST USE 2-16-2010; IN COMMERCE 2-16-2010.  
SUNG IN, EXAMINING ATTORNEY

SN 85-070,686. PERSONAL COMMERCE CORP., NEW YORK, NY. FILED 6-24-2010.

LOVE YOUR STUFF

THE MARK CONSISTS OF STANDARD CHARACTERS WITHOUT CLAIM TO ANY PARTICULAR FONT, STYLE, SIZE, OR COLOR.

FOR PROVIDING AN ONLINE WEB HOSTING PLATFORM TO INDIVIDUALS AND BUSINESSES FOR MARKETING, SHARING, LENDING, DONATING AND SELLING PRODUCTS, GOODS, SERVICES AND PERSONAL PROPERTY (U.S. CLS. 100 AND 101).

MARY ROSSMAN, EXAMINING ATTORNEY

SN 85-095,877. CROSSROADS SYSTEMS, INC., AUSTIN, TX. FILED 7-29-2010.

MIKROS

THE MARK CONSISTS OF STANDARD CHARACTERS WITHOUT CLAIM TO ANY PARTICULAR FONT, STYLE, SIZE, OR COLOR.

FOR SOFTWARE AS A SERVICE (SAAS) FEATURING SOFTWARE IN THE FIELD OF BACKUP, STORAGE AND RESTORATION OF DATA; CLOUD COMPUTING FEATURING SOFTWARE FOR USE IN VIEWING, MEASURING, AND MANAGING A DATA AND NETWORK STORAGE INFRASTRUCTURE (U.S. CLS. 100 AND 101).

LINDA ORNDORFF, EXAMINING ATTORNEY



**CLASS 42—(Continued).**

SN 85-099,277. PHYSICAL OPTICS CORPORATION, TORRANCE, CA. FILED 8-3-2010.

**CLASS 42—(Continued).**

SN 85-107,161. INTERGRID LIMITED, WELLINGTON, NEW ZEALAND, FILED 8-13-2010.

**TECHNOLOGY THAT MAKES A DIFFERENCE**

THE MARK CONSISTS OF STANDARD CHARACTERS WITHOUT CLAIM TO ANY PARTICULAR FONT, STYLE, SIZE, OR COLOR.

NO CLAIM IS MADE TO THE EXCLUSIVE RIGHT TO USE "TECHNOLOGY", APART FROM THE MARK AS SHOWN.

FOR DESIGN, ENGINEERING, RESEARCH, AND DEVELOPMENT SERVICES IN THE FIELD OF PHOTONIC SYSTEMS, ELECTRO-OPTICS, HOLOGRAPHY, INFORMATION TECHNOLOGY AND APPLIED TECHNOLOGY (U.S. CLS. 100 AND 101).

FIRST USE 2-5-2010; IN COMMERCE 2-5-2010.  
ALICE BENMAMAN, EXAMINING ATTORNEY

**GREENBUTTON**

SN 85-102,251. XORI CORPORATION, SEATTLE, WA. FILED 8-6-2010.

**XORI**

THE MARK CONSISTS OF STANDARD CHARACTERS WITHOUT CLAIM TO ANY PARTICULAR FONT, STYLE, SIZE, OR COLOR.

THE WORD(S) "XORI" HAS NO MEANING IN A FOREIGN LANGUAGE.

FOR SCIENTIFIC RESEARCH AND DEVELOPMENT; RESEARCH AND DEVELOPMENT IN THE PHARMACEUTICAL AND BIOTECHNOLOGY FIELDS; SCIENTIFIC, BIOLOGICAL AND MEDICAL RESEARCH RELATED TO THE DISCOVERY AND DEVELOPMENT OF MONOCLONAL ANTIBODIES FOR THERAPEUTIC, DIAGNOSTIC AND RESEARCH PURPOSES; BIOCHEMICAL DEVELOPMENT OF MONOCLONAL ANTIBODIES FOR THERAPEUTIC, DIAGNOSTIC AND RESEARCH PURPOSES; DEVELOPMENT OF DRUGS AND THERAPEUTICS FOR RESEARCH, DIAGNOSIS, AND THE TREATMENT OF A WIDE VARIETY OF DISEASES AND OTHER CONDITIONS, INCLUDING CANCER, IMMUNE DISORDERS AND INFECTIOUS DISEASES (U.S. CLS. 100 AND 101).

JAMES LOVELACE, EXAMINING ATTORNEY

THE MARK CONSISTS OF STANDARD CHARACTERS WITHOUT CLAIM TO ANY PARTICULAR FONT, STYLE, SIZE, OR COLOR.

PRIORITY CLAIMED UNDER SEC. 44(D) ON NEW ZEALAND APPLICATION NO. 819678, FILED 2-15-2010, REG. NO. 819678, DATED 2-15-2010, EXPIRES 2-15-2020.

FOR PROVISION AND MANAGEMENT OF CLOUD COMPUTING SYSTEMS AND APPLICATIONS FOR OTHERS; PROVIDING SOFTWARE FOR ACCESSING AND USING A CLOUD COMPUTING NETWORK; CONSULTING IN THE FIELD OF CLOUD COMPUTING NETWORKS AND APPLICATIONS; COMPUTER SERVICES, NAMELY, PROVIDING VIRTUAL AND CLOUD COMPUTING ENVIRONMENTS, INCLUDING THOSE ACCESSIBLE VIA THE INTERNET AND ORGANIZATION NETWORKS; RENTAL OF CLOUD COMPUTING HARDWARE, SOFTWARE AND NETWORKS; RENTAL OF DATA PROCESSING SYSTEMS AND WEB SERVERS; APPLICATION SERVICE PROVIDER ASP SERVICES, NAMELY, PROVIDING, HOSTING, MANAGING, DEVELOPING, AND MAINTAINING APPLICATIONS, SOFTWARE, WEBSITES, AND DATABASES; DESIGN, DEVELOPMENT AND INSTALLATION OF NETWORKS, SOFTWARE AND APPLICATIONS; COMPUTER SYSTEMS ANALYSIS; PROVIDING SEARCH ENGINES; HOSTING WEBSITES; COMPUTER TIME SHARING; ENCRYPTION OF COMPUTER DATA; RENTAL AND LEASING OF MEMORY, SPACE AND USE OF SERVERS, COMPUTERS, SUPERCOMPUTERS AND PROGRAMS; RENTAL OF USE OF COMPUTER AND SUPERCOMPUTERS, INCLUDING THE COMPUTATIONAL FUNCTIONS OF COMPUTERS AND SUPERCOMPUTERS; ADVISORY, CONSULTANCY AND INFORMATION SERVICES IN RESPECT OF THE FOREGOING SERVICES (U.S. CLS. 100 AND 101).

MARGERY A. TIERNEY, EXAMINING ATTORNEY

**CLASS 42—(Continued).**

SN 85-112,842. NUVIDA DATA FORENSICS, HILLSBOROUGH, NJ. FILED 8-21-2010.



NO CLAIM IS MADE TO THE EXCLUSIVE RIGHT TO USE "DATA FORENSICS", APART FROM THE MARK AS SHOWN.

THE COLOR(S) BLUE AND BLACK IS/ARE CLAIMED AS A FEATURE OF THE MARK.

THE MARK CONSISTS OF A BLUE WAVE SHAPED DESIGN. TO THE RIGHT OF THE DESIGN IS THE WORD "NUVIDA" IN BOLD BLACK FOOTLIGHT MT LIGHT FONT ABOVE THE WORDS "DATA FORENSICS" IN SMALLER BLACK FOOTLIGHT MT LIGHT FONT. THE WORD "WHERE DATA COMES TO LIFE" APPEARS IN BLUE FOOTLIGHT MT LIGHT FONT LETTERS BELOW THE TAIL OF THE WAVE SYMBOL.

FOR COMPUTER FORENSIC SERVICES (U.S. CLS. 100 AND 101).

FIRST USE 2-4-2010; IN COMMERCE 2-4-2010.  
KATINA MISTER, EXAMINING ATTORNEY

SN 85-114,721. WEST VIRGINIA UNIVERSITY, MORGANTOWN, WV. FILED 8-24-2010.

# AVESTAR

THE MARK CONSISTS OF STANDARD CHARACTERS WITHOUT CLAIM TO ANY PARTICULAR FONT, STYLE, SIZE, OR COLOR.

FOR PROVIDING SCIENTIFIC RESEARCH FACILITIES, NAMELY, A RESEARCH CENTER EQUIPPED WITH SCIENTIFIC EQUIPMENT IN THE NATURE OF A POWER GENERATION SIMULATOR COMPLETE WITH CARBON CAPTURE COMPONENTS (U.S. CLS. 100 AND 101).

KEVIN CORWIN, EXAMINING ATTORNEY

**CLASS 42—(Continued).**

SN 85-116,177. WILSON, ERIC C, DBA WEB BASIX INC, RALEIGH, NC. AND WEB BASIX INC, APEX, NC. FILED 8-26-2010.

## WEB BASIX INC.

THE MARK CONSISTS OF STANDARD CHARACTERS WITHOUT CLAIM TO ANY PARTICULAR FONT, STYLE, SIZE, OR COLOR.

NO CLAIM IS MADE TO THE EXCLUSIVE RIGHT TO USE "WEB" AND "INC.", APART FROM THE MARK AS SHOWN.

FOR ADVISORY SERVICES IN THE FIELD OF PRODUCT DEVELOPMENT AND QUALITY IMPROVEMENT OF SOFTWARE; APPLICATION SERVICE PROVIDER, NAMELY, HOSTING, MANAGING, DEVELOPING, ANALYZING, AND MAINTAINING APPLICATIONS, SOFTWARE, AND WEB SITES, OF OTHERS IN THE FIELDS OF ADVERTISING AND MARKETING; APPLICATION SERVICE PROVIDER, NAMELY, HOSTING, MANAGING, DEVELOPING, ANALYZING, AND MAINTAINING APPLICATIONS, SOFTWARE, AND WEB SITES, IN THE FIELDS OF PERSONAL PRODUCTIVITY, WIRELESS COMMUNICATION, MOBILE INFORMATION ACCESS, AND REMOTE DATA MANAGEMENT FOR WIRELESS DELIVERY OF CONTENT TO HANDHELD COMPUTERS, LAPTOPS AND MOBILE ELECTRONIC DEVICES; COMPUTER COMPATIBILITY SERVICES, NAMELY, DATA MAPPING; COMPUTER CONSULTATION; COMPUTER HARDWARE AND SOFTWARE CONSULTING SERVICES; COMPUTER HARDWARE AND SOFTWARE DESIGN; COMPUTER MONITORING SERVICE WHICH TRACKS APPLICATION SOFTWARE PERFORMANCE, PERFORMS PERIODIC MAINTENANCE AND PROVIDES REPORTS AND ALERTS CONCERNING SUCH PERFORMANCE; COMPUTER MONITORING SERVICE WHICH TRACKS HARDWARE PERFORMANCE AND PROCESSES AND SENDS OUT HISTORICAL REPORTS AND ALERTS; COMPUTER PROGRAMMING; COMPUTER PROGRAMMING AND COMPUTER SYSTEM ANALYSIS; COMPUTER PROGRAMMING AND MAINTENANCE OF COMPUTER PROGRAMS; COMPUTER PROGRAMMING AND SOFTWARE DESIGN; COMPUTER PROGRAMMING CONSULTANCY; COMPUTER PROGRAMMING FOR OTHERS; COMPUTER PROGRAMMING SERVICES; COMPUTER PROGRAMMING SERVICES, NAMELY, CONTENT CREATION FOR VIRTUAL WORLDS AND THREE DIMENSIONAL PLATFORMS; COMPUTER PROJECT MANAGEMENT SERVICES; COMPUTER SERVICES, NAMELY, DESIGNING AND IMPLEMENTING WEB SITES FOR OTHERS; COMPUTER SERVICES, NAMELY, MANAGING WEB SITES FOR OTHERS; COMPUTER SERVICES, NAMELY, PROVIDING A WEB-BASED SYSTEM AND ONLINE PORTAL FOR CUSTOMERS TO REMOTELY MANAGE, ADMINISTER, MODIFY AND CONTROL THEIR END USER COMPUTER DEVICES, DATA AND SOFTWARE APPLICATIONS; COMPUTER SOFTWARE CONSULTING; COMPUTER SOFTWARE DESIGN; COMPUTER SOFTWARE DESIGN AND UPDATING; COMPUTER SOFTWARE DESIGN, COMPUTER PROGRAMMING, OR MAINTENANCE OF COMPUTER SOFTWARE; COMPUTER SOFTWARE DEVELOPMENT; COMPUTER SOFTWARE DEVELOPMENT AND COMPUTER PROGRAMMING DEVELOPMENT FOR OTHERS; COMPUTER SOFTWARE INSTALLATION AND MAINTENANCE; CONSULTANCY IN THE FIELD OF SOFTWARE DESIGN; CONSULTATION SERVICES IN THE FIELDS OF SELECTION, IMPLEMENTATION AND USE OF COMPUTER HARDWARE AND SOFTWARE SYSTEMS FOR OTHERS; CONSULTING SERVICES IN THE FIELD OF DESIGN, SELECTION, IMPLEMENTATION AND USE OF COMPUTER HARDWARE AND

**CLASS 42—(Continued).**

SOFTWARE SYSTEMS FOR OTHERS; CONSULTING SERVICES IN THE FIELD OF SOFTWARE AS A SERVICE (SAAS); CREATION, DESIGN, DEVELOPMENT AND MAINTENANCE OF WEB SITES FOR THIRD PARTIES; CUSTOMIZATION OF COMPUTER HARDWARE AND SOFTWARE; CUSTOMIZED SOFTWARE DEVELOPMENT SERVICES; DATABASE DESIGN AND DEVELOPMENT; DATABASE DEVELOPMENT SERVICES; DESIGN AND DEVELOPMENT OF COMPUTER SOFTWARE; DESIGN AND WRITING OF COMPUTER SOFTWARE; DESIGN OF HOME PAGES, COMPUTER SOFTWARE AND WEB SITES; DESIGN, DEVELOPMENT AND CONSULTING SERVICES IN THE FIELD OF SOFTWARE FOR CONTENT MANAGEMENT; DESIGN, DEVELOPMENT AND IMPLEMENTATION OF SOFTWARE; DESIGN, DEVELOPMENT, INSTALLATION AND MAINTENANCE OF COMPUTER SOFTWARE; DESIGN, INSTALLATION, UPDATING AND MAINTENANCE OF COMPUTER SOFTWARE; DESIGN, MAINTENANCE, DEVELOPMENT AND UPDATING OF COMPUTER SOFTWARE; DESIGNING AND DEVELOPING WEBPAGES ON THE INTERNET; DEVELOPING COMPUTER SOFTWARE; DEVELOPMENT OF SOFTWARE FOR SECURE NETWORK OPERATIONS; DEVELOPMENT, DESIGN AND UPDATING OF HOME PAGES; DEVELOPMENT, UPDATING AND MAINTENANCE OF SOFTWARE AND DATA BASES; INSTALLATION AND MAINTENANCE OF COMPUTER SOFTWARE; INSTALLATION OF COMPUTER SOFTWARE; INSTALLING COMPUTER PROGRAMS; INTEGRATION OF COMPUTER SYSTEMS AND NETWORKS; MAINTENANCE AND UPDATING OF COMPUTER SOFTWARE; MAINTENANCE AND UPGRADING OF COMPUTER SOFTWARE; MAINTENANCE OF COMPUTER SOFTWARE; PROGRAMMING OF COMPUTER SOFTWARE FOR OTHERS; RESEARCH AND DEVELOPMENT OF COMPUTER SOFTWARE; RESEARCH, DEVELOPMENT, DESIGN AND UPGRADING OF COMPUTER SOFTWARE; SOFTWARE DESIGN AND DEVELOPMENT; UPDATING AND DESIGN OF COMPUTER SOFTWARE; UPDATING AND MAINTENANCE OF COMPUTER SOFTWARE; WEBSITE DESIGN AND DEVELOPMENT FOR OTHERS; WRITING AND UPDATING COMPUTER SOFTWARE (U.S. CLS. 100 AND 101).

FIRST USE 9-1-1998; IN COMMERCE 9-1-1998.  
SANI KHOURI, EXAMINING ATTORNEY

**CLASS 42—(Continued).**

SN 85-117,215. PEER 1 NETWORK ENTERPRISES, INC., VANCOUVER, CANADA, FILED 8-27-2010.

## PEER 1 HOSTING

THE MARK CONSISTS OF STANDARD CHARACTERS WITHOUT CLAIM TO ANY PARTICULAR FONT, STYLE, SIZE, OR COLOR.

OWNER OF U.S. REG. NOS. 3,306,973, 3,306,978 AND OTHERS.

NO CLAIM IS MADE TO THE EXCLUSIVE RIGHT TO USE "HOSTING", APART FROM THE MARK AS SHOWN. SEC. 2(F) AS TO "PEER 1".

FOR MANAGED COMPUTER SERVICES, NAMELY, COMPUTER SYSTEM ADMINISTRATION FOR OTHERS, PATCHING OF COMPUTERS, MANAGED FIREWALLS, MANAGED BACKUPS, MONITORING THE COMPUTER SYSTEMS OF OTHERS FOR TECHNICAL PURPOSES, SECURITY SCANS IN THE NATURE OF COMPUTER VIRUS PROTECTION SERVICES, SOFTWARE INSTALLATION AND UNINSTALLATION, AND DOMAIN CONFIGURATION PROVIDED ON AN INFRASTRUCTURE COMPRISED OF SERVERS AND RELATED DEVICES DEDICATED TO A SPECIFIC CUSTOMER AND APPLICATION; COMPUTER COLOCATION SERVICES, NAMELY, PROVIDING FACILITIES FOR THE LOCATION OF COMPUTER SERVERS WITH THE EQUIPMENT OF OTHERS; DEDICATED SERVER HOSTING (U.S. CLS. 100 AND 101).

FIRST USE 12-0-2009; IN COMMERCE 12-0-2009.  
AMY ALFIERI, EXAMINING ATTORNEY

SN 85-121,956. HENGTIAN SERVICES LLC, CAMBRIDGE, MA. FILED 9-2-2010.

## HengTian Services

THE MARK CONSISTS OF STANDARD CHARACTERS WITHOUT CLAIM TO ANY PARTICULAR FONT, STYLE, SIZE, OR COLOR.

NO CLAIM IS MADE TO THE EXCLUSIVE RIGHT TO USE "SERVICES", APART FROM THE MARK AS SHOWN.

THE ENGLISH TRANSLATION OF THE WORD "HENGTIAN" IN THE MARK IS "EVERLASTING DAY".

FOR CONSULTING SERVICES, NAMELY, COMPUTER SOFTWARE AND APPLICATION DESIGN AND DEVELOPMENT FOR OTHERS (U.S. CLS. 100 AND 101).

FIRST USE 7-21-2010; IN COMMERCE 7-21-2010.  
MARK SHINER, EXAMINING ATTORNEY

**CLASS 42—(Continued).**

SN 85-125,416. CHRISTIE TECHNOLOGY CORPORATION, GENEVA, IL. FILED 9-8-2010.

## Think Local, Simple and Sustainable!

THE MARK CONSISTS OF STANDARD CHARACTERS WITHOUT CLAIM TO ANY PARTICULAR FONT, STYLE, SIZE, OR COLOR.

FOR CONSULTING IN THE FIELD OF INFORMATION TECHNOLOGY; CONSULTING IN THE FIELD OF TELECOMMUNICATIONS TECHNOLOGY; CONSULTING IN THE FIELD OF VIRTUALIZATION TECHNOLOGIES FOR ENTERPRISES AND BUSINESSES; CONSULTING SERVICES IN THE FIELD OF COMPUTER-BASED INFORMATION SYSTEMS FOR BUSINESSES; INFORMATION TECHNOLOGY CONSULTATION; PLANNING, DESIGN AND IMPLEMENTATION OF VIRTUALIZATION TECHNOLOGIES FOR ENTERPRISES AND BUSINESSES; PROVIDING AN ON-LINE NETWORK ENVIRONMENT THAT FEATURES TECHNOLOGY THAT ENABLES USERS TO SHARE DATA; PROVIDING PLANNING AND ENGINEERING SERVICES IN THE FIELD OF INFORMATION AND COMMUNICATIONS NETWORKS; PROVIDING TECHNOLOGICAL INFORMATION ABOUT ENVIRONMENTALLY-CONSCIOUS AND GREEN INNOVATIONS; TECHNICAL CONSULTING AND ASSISTANCE WITH COMPUTER-BASED INFORMATION SYSTEMS AND COMPONENTS; TECHNICAL CONSULTING SERVICES IN THE FIELDS OF DATA-CENTER ARCHITECTURE, PUBLIC AND PRIVATE CLOUD COMPUTING SOLUTIONS, AND EVALUATION AND IMPLEMENTATION OF INTERNET TECHNOLOGY AND SERVICES; TECHNOLOGICAL CONSULTATION IN THE TECHNOLOGY FIELD OF COMPUTER HARDWARE SYSTEMS (U.S. CLS. 100 AND 101).

FIRST USE 1-5-2010; IN COMMERCE 1-10-2010.  
ANGELA DUONG, EXAMINING ATTORNEY

SN 85-125,971. MENDEZ MEDIA MIAMI, LLC, DBA MENDEZMEDIA, MIAMI BEACH, FL. FILED 9-9-2010.

## MENDEZMEDIA

THE MARK CONSISTS OF STANDARD CHARACTERS WITHOUT CLAIM TO ANY PARTICULAR FONT, STYLE, SIZE, OR COLOR.

SEC. 2(F).

FOR CREATION, DESIGN, DEVELOPMENT AND MAINTENANCE OF WEB SITES FOR THIRD PARTIES; PROVIDING GRAPHIC AND MULTIMEDIA DESIGN SERVICES FOR THE PURPOSE OF PROMOTING THE GOODS AND SERVICES OF OTHERS (U.S. CLS. 100 AND 101).

FIRST USE 11-5-2002; IN COMMERCE 11-5-2002.  
KEVON CHISOLM, EXAMINING ATTORNEY

**CLASS 42—(Continued).**

SN 85-127,503. PRIZE DRIVEN LLC, WILLINGBORO, NJ. FILED 9-11-2010.



THE MARK CONSISTS OF THE STYLIZED TERMS "PRIZE DRIVEN" WHERE THE "P" IS CHECKERED. FOR DESIGNING WEBSITES (U.S. CLS. 100 AND 101). FIRST USE 5-1-2008; IN COMMERCE 4-1-2009.  
HELENE LIWINSKI, EXAMINING ATTORNEY

SN 85-129,164. SCREAMING EAGLE LLC, LEESBURG, VA. AND RED EAGLE LLC, LEESBURG, VA. FILED 9-14-2010.

## AEBA CERTIFIED

THE MARK CONSISTS OF STANDARD CHARACTERS WITHOUT CLAIM TO ANY PARTICULAR FONT, STYLE, SIZE, OR COLOR.

NO CLAIM IS MADE TO THE EXCLUSIVE RIGHT TO USE "CERTIFIED", APART FROM THE MARK AS SHOWN. FOR TESTING, ANALYSIS AND EVALUATION OF THE SERVICES OF OTHERS FOR THE PURPOSE OF CERTIFICATION (U.S. CLS. 100 AND 101).

FIRST USE 12-1-2008; IN COMMERCE 12-1-2008.  
JEFFERY COWARD, EXAMINING ATTORNEY

**CLASS 42—(Continued).**

SN 85-133,195. LISA HUNT, BROOKLYN, NY. FILED 9-20-2010.

**LISA HUNT CREATIVE**

THE MARK CONSISTS OF STANDARD CHARACTERS WITHOUT CLAIM TO ANY PARTICULAR FONT, STYLE, SIZE, OR COLOR.

THE NAME(S), PORTRAIT(S), AND/OR SIGNATURE(S) SHOWN IN THE MARK IDENTIFIES "LISA HUNT", WHOSE CONSENT(S) TO REGISTER IS MADE OF RECORD.

FOR DESIGN FOR OTHERS IN THE FIELD OF GRAPHIC DESIGN AND TEXTILE DESIGN; DESIGN OF TEXTILES; GRAPHIC DESIGN (U.S. CLS. 100 AND 101).

FIRST USE 1-1-2008; IN COMMERCE 1-1-2009.  
SKYE YOUNG, EXAMINING ATTORNEY

---

SN 85-135,910. GUARANTY REALTORS, INC., PLANO, TX. FILED 9-22-2010.



NO CLAIM IS MADE TO THE EXCLUSIVE RIGHT TO USE "HOMESUSA" AND ".COM", APART FROM THE MARK AS SHOWN.

THE MARK CONSISTS OF THE ARTISTIC RENDERING OF AN OUTLINE OF A HOUSE WITH THE STYLIZED WORDS "HOMESUSA" APPEARING IN THE MIDDLE OF THE ARTISTIC RENDERING. THE STYLIZED LETTERING ".COM" APPEARS BELOW "HOMESUSA".

FOR PROVIDING ON-LINE NON-DOWNLOADABLE SOFTWARE FOR ALLOWING HOME BUILDERS TO INPUT NEW HOMES FOR SALE AND HAVE THE HOMES APPEAR IN A LOCAL MULTIPLE LISTING SERVICE (U.S. CLS. 100 AND 101).

FIRST USE 7-1-2007; IN COMMERCE 7-1-2007.  
DEZMONA MIZELLE, EXAMINING ATTORNEY

**CLASS 42—(Continued).**

SN 85-142,120. SCANTRON CORPORATION, EAGAN, MN. FILED 9-30-2010.

**REPORTFOLIO SERIES**

THE MARK CONSISTS OF STANDARD CHARACTERS WITHOUT CLAIM TO ANY PARTICULAR FONT, STYLE, SIZE, OR COLOR.

NO CLAIM IS MADE TO THE EXCLUSIVE RIGHT TO USE "SERIES", APART FROM THE MARK AS SHOWN.

FOR APPLICATION SERVICE PROVIDER (ASP) FEATURING SOFTWARE FOR USE IN THE FIELD OF EDUCATION FOR REPORTING AND ANALYSIS OF DATA (U.S. CLS. 100 AND 101).

ROBERT STRUCK, EXAMINING ATTORNEY

---

SN 85-143,329. OUR WAY MEDIA GROUP LLC, LITTLE NECK, NY. FILED 10-1-2010.

**HOOD HOOT**

THE MARK CONSISTS OF STANDARD CHARACTERS WITHOUT CLAIM TO ANY PARTICULAR FONT, STYLE, SIZE, OR COLOR.

FOR PROVIDING CUSTOMIZED ON-LINE WEB PAGES AND DATA FEEDS FEATURING USER-DEFINED INFORMATION, WHICH INCLUDES BLOG POSTS, NEW MEDIA CONTENT, OTHER ON-LINE CONTENT, AND ON-LINE WEB LINKS TO OTHER WEBSITES, ALL RELATING TO COMMUNITY MATTERS, USER INTERESTS, NEWS, ISSUES, EVENTS, AND GENERAL INTEREST TOPICS FOR COMMENTARY AND DISCUSSION (U.S. CLS. 100 AND 101).

ELLEN B. AWRICH, EXAMINING ATTORNEY

---

SN 85-143,339. OUR WAY MEDIA GROUP LLC, LITTLE NECK, NY. FILED 10-1-2010.

**HOODHOOT**

THE MARK CONSISTS OF STANDARD CHARACTERS WITHOUT CLAIM TO ANY PARTICULAR FONT, STYLE, SIZE, OR COLOR.

FOR PROVIDING CUSTOMIZED ON-LINE WEB PAGES AND DATA FEEDS FEATURING USER-DEFINED INFORMATION, WHICH INCLUDES BLOG POSTS, NEW MEDIA CONTENT, OTHER ON-LINE CONTENT, AND ON-LINE WEB LINKS TO OTHER WEBSITES, ALL RELATING TO COMMUNITY MATTERS, USER INTERESTS, NEWS, ISSUES, EVENTS, AND GENERAL INTEREST TOPICS FOR COMMENTARY AND DISCUSSION (U.S. CLS. 100 AND 101).

ELLEN B. AWRICH, EXAMINING ATTORNEY

**CLASS 42—(Continued).**

SN 85-143,344. OUR WAY MEDIA GROUP LLC, LITTLE NECK, NY. FILED 10-1-2010.

**GIVE A HOOT**

THE MARK CONSISTS OF STANDARD CHARACTERS WITHOUT CLAIM TO ANY PARTICULAR FONT, STYLE, SIZE, OR COLOR.

FOR PROVIDING CUSTOMIZED ON-LINE WEB PAGES AND DATA FEEDS FEATURING USER-DEFINED INFORMATION, WHICH INCLUDES BLOG POSTS, NEW MEDIA CONTENT, OTHER ON-LINE CONTENT, AND ON-LINE WEB LINKS TO OTHER WEBSITES, ALL RELATING TO COMMUNITY MATTERS, USER INTERESTS, NEWS, ISSUES, EVENTS, AND GENERAL INTEREST TOPICS FOR COMMENTARY AND DISCUSSION (U.S. CLS. 100 AND 101).

ELLEN B. AWRICH, EXAMINING ATTORNEY

---

SN 85-144,057. ISTREAMIT INTERNATIONAL LLC, DBA BIZIDEO, EAGAN, MN. FILED 10-4-2010.

**BIZIDEO**

THE MARK CONSISTS OF STANDARD CHARACTERS WITHOUT CLAIM TO ANY PARTICULAR FONT, STYLE, SIZE, OR COLOR.

FOR PROVIDING AN INTERNET PORTAL FOR CUSTOMERS ALLOWING THEM TO BOTH RECEIVE NON-DOWNLOADABLE SOFTWARE AND TO UP LOAD SELECTED DATA OR SOFTWARE IN ORDER TO CREATE CUSTOMER UNIQUE VIDEO-RESPONSE PROGRAMMED BUSINESS SYSTEMS FOR THE INTERNET (U.S. CLS. 100 AND 101).

FIRST USE 3-15-2006; IN COMMERCE 3-15-2006.  
ODESSA BIBBINS, EXAMINING ATTORNEY

---

SN 85-144,457. PROMOTION EXECUTION PARTNERS, LLC, DBA PEP, LLC, CINCINNATI, OH. FILED 10-4-2010.

**PEPCONNECT**

THE MARK CONSISTS OF STANDARD CHARACTERS WITHOUT CLAIM TO ANY PARTICULAR FONT, STYLE, SIZE, OR COLOR.

FOR PROVIDING A WEB-BASED SYSTEM AND ON-LINE PORTAL FOR CUSTOMERS TO REMOTELY TRACK, MANAGE, PLAN, REPORT, AND MONITOR THE EXECUTION OF PROMOTIONAL CAMPAIGNS AND PROJECTS AND MARKETING SERVICES PROVIDED TO SUCH CUSTOMERS (U.S. CLS. 100 AND 101).

FIRST USE 8-2-2006; IN COMMERCE 8-2-2006.  
TASNEEM HUSSAIN, EXAMINING ATTORNEY

**CLASS 42—(Continued).**

SN 85-145,342. AG SOFTWARE DESIGNS, LLC, JONES-BORO, AR. FILED 10-5-2010.

**FIELDRX**

THE MARK CONSISTS OF STANDARD CHARACTERS WITHOUT CLAIM TO ANY PARTICULAR FONT, STYLE, SIZE, OR COLOR.

FOR PROVIDING TEMPORARY USE OF A WEB-BASED SOFTWARE APPLICATION FOR USE IN DATA MANAGEMENT IN THE AREA OF AGRICULTURE (U.S. CLS. 100 AND 101).

FIRST USE 5-22-2010; IN COMMERCE 5-22-2010.  
AMY ALFIERI, EXAMINING ATTORNEY

---

SN 85-145,512. SCHOOL DYNAMICS, INC, HARTSVILLE, SC. FILED 10-5-2010.



THE MARK CONSISTS OF THE STYLIZED WORD "OMNI" WITH A BALL OF ELECTRIC PARTICLES INSIDE THE LETTER "O" AND CONSISTING OF SIX RANDOMLY PLACED SOLID CIRCLES CONNECTED BY CURVED LINES.

THE ENGLISH TRANSLATION OF "OMNI" IN THE MARK IS "ALL".

FOR PROVIDING TEMPORARY USE OF ON-LINE NON-DOWNLOADABLE SOFTWARE FOR DATA MANAGEMENT IN THE FIELD OF ADMINISTRATION OF SCHOOLS (U.S. CLS. 100 AND 101).

FIRST USE 2-0-2010; IN COMMERCE 9-0-2010.  
BILL DAWE, EXAMINING ATTORNEY

**CLASS 42—(Continued).**

SN 85-146,146. MYTWEENLIFE, LLC, AUSTIN, TX. FILED 10-6-2010.

## HULABOARD

THE MARK CONSISTS OF STANDARD CHARACTERS WITHOUT CLAIM TO ANY PARTICULAR FONT, STYLE, SIZE, OR COLOR.

FOR COMPUTER SERVICES, NAMELY, HOSTING AN ONLINE COMMUNITY WEBSITE FOR REGISTERED USERS TO PARTICIPATE IN DISCUSSIONS; HOSTING AN ONLINE COMMUNITY WEBSITE TO ALLOW REGISTERED USERS TO OBTAIN FEEDBACK FROM PEERS; HOSTING AN ONLINE COMMUNITY WEBSITE TO FORM VIRTUAL COMMUNITIES; HOSTING AN ONLINE COMMUNITY WEBSITE TO ENGAGE IN SOCIAL NETWORKING; AND HOSTING AN ONLINE COMMUNITY WEBSITE FEATURING EDUCATIONAL AND ENTERTAINMENT ACTIVITIES FOR CHILDREN (U.S. CLS. 100 AND 101).

FIRST USE 5-31-2009; IN COMMERCE 5-31-2009.  
JEFFREY LOOK, EXAMINING ATTORNEY

SN 85-148,326. DESIGN FRIENDZY, CALIFON, NJ. FILED 10-8-2010.

## Design Friendzy

THE MARK CONSISTS OF STANDARD CHARACTERS WITHOUT CLAIM TO ANY PARTICULAR FONT, STYLE, SIZE, OR COLOR.

NO CLAIM IS MADE TO THE EXCLUSIVE RIGHT TO USE "DESIGN", APART FROM THE MARK AS SHOWN.

FOR INTERIOR DESIGN SERVICES AND CONSULTATION SERVICES IN THE FIELD OF INTERIOR DESIGN (U.S. CLS. 100 AND 101).

BILL DAWE, EXAMINING ATTORNEY

SN 85-149,115. ARICHE, FESTUS J, LAS VEGAS, NV. FILED 10-9-2010.

## Travendar

THE MARK CONSISTS OF STANDARD CHARACTERS WITHOUT CLAIM TO ANY PARTICULAR FONT, STYLE, SIZE, OR COLOR.

FOR COMPUTER SERVICES, NAMELY, INTERACTIVE HOSTING SERVICES WHICH ALLOW THE USER TO PUBLISH INFORMATION ABOUT EVENTS ON-LINE (U.S. CLS. 100 AND 101).

FIRST USE 10-9-2010; IN COMMERCE 10-9-2010.  
CHRISTOPHER BUONGIORNO, EXAMINING ATTORNEY

**CLASS 42—(Continued).**

SN 85-150,286. EESIFLO, INC., MECHANICSBURG, PA. FILED S.R. 10-12-2010; AM. P.R. 2-1-2011.

## FLOWRENTAL.COM

THE MARK CONSISTS OF STANDARD CHARACTERS WITHOUT CLAIM TO ANY PARTICULAR FONT, STYLE, SIZE, OR COLOR.

FOR PROVIDING A WEB SITE AT WHICH USERS CAN RENT HARDWARE AND SOFTWARE THAT FUNCTIONS AS AN ULTRASONIC FLOW METER, NAMELY, HARDWARE AND SOFTWARE THAT MEASURES THE VOLUME OR MASS OF FLOW OF A FLUID IN A PIPE (U.S. CLS. 100 AND 101).

FIRST USE 1-21-2005; IN COMMERCE 1-21-2005.  
KATHERINE E. HALMEN, EXAMINING ATTORNEY

SN 85-150,402. WATERMARK RESEARCH PARTNERS, INC, INDIANAPOLIS, IN. FILED 10-12-2010.



THE COLOR(S) DARK BLUE AND GREEN IS/ARE CLAIMED AS A FEATURE OF THE MARK.

THE MARK CONSISTS OF THE STYLIZED TEXT "WATERMARK EDGE" WITH A VERTICAL LINE BETWEEN THE TWO WORDS. THE WORD "WATERMARK" AND THE VERTICAL LINE ARE DARK BLUE AND THE WORD "EDGE" IS GREEN. A REFLECTION OF THE SAME IS IMMEDIATELY BELOW THE TEXT.

FOR SOFTWARE AS A SERVICE (SAAS) SERVICES, NAMELY, HOSTING SOFTWARE FOR USE BY OTHERS FOR USE IN HOSTING, MANAGING, DEVELOPING, ANALYZING, AND MAINTAINING APPLICATIONS, SOFTWARE, AND WEB SITES IN THE FIELDS OF HEALTHCARE AND LIFE SCIENCES; APPLICATION SERVICE PROVIDER, NAMELY, HOSTING, MANAGING, DEVELOPING, ANALYZING, AND MAINTAINING APPLICATIONS, SOFTWARE, AND WEB SITES, OF OTHERS IN THE FIELDS OF HEALTHCARE AND LIFE SCIENCES (U.S. CLS. 100 AND 101).

FIRST USE 1-1-2010; IN COMMERCE 1-1-2010.  
AISHA SALEM, EXAMINING ATTORNEY

**CLASS 42—(Continued).**

SN 85-150,579. ASCENDER COMMERCE, LLC, NOBLE, OK. FILED 10-12-2010.



THE COLOR(S) RED, BLUE IS/ARE CLAIMED AS A FEATURE OF THE MARK.

THE MARK CONSISTS OF THE WORD "ASCENDER" IN BLUE NEXT TO THE WORD "CART" IN RED NEAR A BLUE STYLIZED ROCKET WITH A V-SHAPED BODY WITH A "C" IN THE INTERIOR OF THE "V" SHAPED WITH RED FLAMES EXTENDING FROM THE BOTTOM OF THE "C".

FOR PROVIDING TEMPORARY USE OF ONLINE NON-DOWNLOADABLE E-COMMERCE SOFTWARE TO ACCEPT AND PROCESS ELECTRONIC ORDERING TRANSACTIONS VIA A GLOBAL COMPUTER NETWORK (U.S. CLS. 100 AND 101).

FIRST USE 10-12-2010; IN COMMERCE 10-12-2010.  
LINDA M. KING, EXAMINING ATTORNEY

**CLASS 42—(Continued).**

SN 85-150,792. UNISOURCE WORLDWIDE, INC., NORCROSS, GA. FILED 10-12-2010.



OWNER OF U.S. REG. NOS. 2,953,498, 3,344,969 AND OTHERS.

NO CLAIM IS MADE TO THE EXCLUSIVE RIGHT TO USE "ENGINEERED SOLUTIONS" AND "IN PACKAGING", APART FROM THE MARK AS SHOWN.

THE LINING IN THE DRAWING IS A FEATURE OF THE MARK.

THE COLOR(S) RED, BLACK, GRAY IS/ARE CLAIMED AS A FEATURE OF THE MARK.

THE MARK CONSISTS OF THE LETTER "U" IN RED WITH A STRIPED RED MIRROR IMAGE "U" ABOVE THE WORD "UNISOURCE" IN BLACK; THESE ELEMENTS TO THE LEFT OF A GRAY VERTICAL LINE; WITH THE WORD "ENGINEERED" IN RED AND "SOLUTIONS" IN GRAY ABOVE A GRAY RULER AND THE PHRASE "INNOVATORS IN PACKAGING" TO THE RIGHT OF THE GRAY VERTICAL LINE, ALL ON A WHITE BACKGROUND.

FOR PACKAGING DESIGN; PACKAGING DESIGN FOR OTHERS (U.S. CLS. 100 AND 101).

JOHN E. MICHOS, EXAMINING ATTORNEY

SN 85-150,619. SLEUTH, INC., BRADENTON, FL. FILED 10-12-2010.



THE MARK CONSISTS OF MULTIPLE CIRCLES WITHIN THEMSELVES BEHIND THE WORD "SLEUTH".

FOR UNDERGROUND SYSTEM LOCATION SERVICES AND UNDERGROUND SYSTEM FAILURE LOCATION SERVICES, NAMELY, LOCATING UNDERGROUND PLUMBING AND ELECTRICAL SYSTEMS, LEAKS AND BROKEN WIRES, REMOTE INSPECTION OF CONCEALED SPACE SERVICES, NAMELY, ACOUSTIC AND VIDEO CAMERA INSPECTION OF PIPES AND OTHER INACCESSIBLE AREAS OF AN EXISTING STRUCTURE OR HOME AND/OR WALL(S) AND VOID(S) AND UNDERGROUND CONCEALED SPACES (U.S. CLS. 100 AND 101).

FIRST USE 10-31-1982; IN COMMERCE 8-15-1984.  
KEVIN DINALLO, EXAMINING ATTORNEY

SN 85-150,818. UNISOURCE WORLDWIDE, INC., NORCROSS, GA. FILED 10-12-2010.



OWNER OF U.S. REG. NOS. 2,953,498, 3,311,894 AND OTHERS.

NO CLAIM IS MADE TO THE EXCLUSIVE RIGHT TO USE "ENGINEERED SOLUTIONS" AND "IN PACKAGING", APART FROM THE MARK AS SHOWN.

THE LINING IN THE DRAWING IS A FEATURE OF THE MARK.

THE COLOR(S) RED, BLACK, GRAY, WHITE IS/ARE CLAIMED AS A FEATURE OF THE MARK.

THE MARK CONSISTS OF THE LETTER "U" IN RED WITH A STRIPED RED MIRROR IMAGE "U" TO THE LEFT OF THE WORD "UNISOURCE" IN BLACK LOWER CASE LETTERS; THE FOREGOING ELEMENTS ABOVE THE WORD "ENGINEERED" IN RED AND "SOLUTIONS" IN GRAY ABOVE A GRAY RULER; THESE ELEMENTS ABOVE THE PHRASE "INNOVATORS IN PACKAGING" IN BLACK; ALL ON A WHITE BACKGROUND.

FOR PACKAGING DESIGN; PACKAGING DESIGN FOR OTHERS (U.S. CLS. 100 AND 101).

JOHN E. MICHOS, EXAMINING ATTORNEY



**CLASS 42—(Continued).**

SN 85-151,607. PERSONAL, INC., WASHINGTON DC, DC. FILED 10-13-2010.

# PERSONAL

THE MARK CONSISTS OF STANDARD CHARACTERS WITHOUT CLAIM TO ANY PARTICULAR FONT, STYLE, SIZE, OR COLOR.

FOR PROVIDING A WEBSITE FEATURING TECHNOLOGY THAT ENABLES USERS TO MANAGE AND SHARE THEIR PROFILES AND DATA IN ORDER TO RECEIVE TARGETED COUPONS, REBATES, DISCOUNTS, PROMOTIONAL MESSAGES AND ADVERTISING FROM THIRD PARTY RETAILERS, MARKETERS AND SERVICE PROVIDERS AND TO RECEIVE TARGETED CONTENT AND INFORMATION FROM PUBLISHERS, MEDIA AND CONTENT SERVICE PROVIDERS (U.S. CLS. 100 AND 101).

REBECCA POVARCHUK, EXAMINING ATTORNEY

**CLASS 42—(Continued).**

SN 85-151,893. CHESHIRE CONSULTING, SAN FRANCISCO, CA. FILED 10-13-2010.

# Cheshire Consulting

THE MARK CONSISTS OF STANDARD CHARACTERS WITHOUT CLAIM TO ANY PARTICULAR FONT, STYLE, SIZE, OR COLOR.

NO CLAIM IS MADE TO THE EXCLUSIVE RIGHT TO USE "CONSULTING", APART FROM THE MARK AS SHOWN.

FOR COMPUTER PROJECT MANAGEMENT SERVICES; COMPUTER SYSTEMS INTEGRATION SERVICES; CONSULTING SERVICES IN THE FIELD OF IMPROVEMENT OF ENGINEERING PROCESSES; DATA MIGRATION SERVICES; DESIGN, DEVELOPMENT AND IMPLEMENTATION OF SOFTWARE; INTEGRATION OF COMPUTER SYSTEMS AND NETWORKS; MAINTENANCE AND UPGRADING OF COMPUTER SOFTWARE (U.S. CLS. 100 AND 101).

FIRST USE 1-12-2009; IN COMMERCE 1-12-2009.  
JOHN DALIER, EXAMINING ATTORNEY

SN 85-152,130. XFORM COMPUTING, DBA VOICECHO LLC, SANTA BARBARA, CA. FILED 10-13-2010.

# AlwaysOnPC

THE MARK CONSISTS OF STANDARD CHARACTERS WITHOUT CLAIM TO ANY PARTICULAR FONT, STYLE, SIZE, OR COLOR.

FOR CLOUD COMPUTING FEATURING SOFTWARE THAT PROVIDES ACCESS TO A VIRTUAL PERSONAL COMPUTER WITH APPLICATIONS AND STORAGE, ACCESSIBLE FROM COMPUTERS, TABLETS, MOBILE DEVICES, AND HDTV SET-TOP BOXES SOFTWARE AS A SERVICE (SAAS) SERVICES, NAMELY, HOSTING SOFTWARE FOR USE BY OTHERS TO RUN PC-CALIBER APPLICATIONS, NAMELY, A BROWSER WITH FLASH FEATURES, WORD PROCESSING, SPREADSHEET, PRESENTATION AND DRAWING EDITOR APPLICATIONS, OR GAMES FROM A MOBILE, DEVICE, TABLET OR HDTV SET-TOP BOX (U.S. CLS. 100 AND 101).

FIRST USE 7-15-2007; IN COMMERCE 7-1-2009.  
KAREN K. BUSH, EXAMINING ATTORNEY

SN 85-151,836. WEBB NELSON, WOODINVILLE, WA. FILED 10-13-2010.

# HOT YES

THE MARK CONSISTS OF STANDARD CHARACTERS WITHOUT CLAIM TO ANY PARTICULAR FONT, STYLE, SIZE, OR COLOR.

FOR PROVIDING ONLINE NONDOWNLOADABLE COMPUTER SOFTWARE FOR SOCIAL NETWORKING PURPOSES FEATURING PERSONALITY TESTS AND GAMES (U.S. CLS. 100 AND 101).

FIRST USE 10-1-2010; IN COMMERCE 10-1-2010.  
ANNE FARRELL, EXAMINING ATTORNEY

**CLASS 42—(Continued).**

SN 85-152,601. CADOTTE, ERNEST, KNOXVILLE, TN.  
FILED 10-14-2010.

**CLASS 42—(Continued).**

SN 85-153,221. CRAIG MILOSCIA, MUNROE FALLS, OH.  
FILED 10-14-2010.

**MARKETPLACE LIVE**

THE MARK CONSISTS OF STANDARD CHARACTERS WITHOUT CLAIM TO ANY PARTICULAR FONT, STYLE, SIZE, OR COLOR.

OWNER OF U.S. REG. NO. 3,653,470.

NO CLAIM IS MADE TO THE EXCLUSIVE RIGHT TO USE "LIVE", APART FROM THE MARK AS SHOWN.

SEC. 2(F) AS TO "MARKETPLACE".

FOR PROVIDING TEMPORARY USE OF ONLINE NON-DOWNLOADABLE EDUCATIONAL SOFTWARE FEATURING INSTRUCTION IN MARKETING AND BUSINESS ADMINISTRATION (U.S. CLS. 100 AND 101).

FIRST USE 9-0-2008; IN COMMERCE 9-0-2008.

KATHERINE CONNOLLY, EXAMINING ATTORNEY

**We Speak Design**

SN 85-153,056. P.E. LAMOREAUX & ASSOCIATES, INC.,  
DBA PELA GEOENVIRONMENTAL, TUSCALOOSA, AL.  
FILED 10-14-2010.



NO CLAIM IS MADE TO THE EXCLUSIVE RIGHT TO USE "GEOENVIRONMENTAL", APART FROM THE MARK AS SHOWN.

THE COLOR(S) BLUE AND GREEN IS/ARE CLAIMED AS A FEATURE OF THE MARK.

THE MARK CONSISTS OF A CIRCLE DIVIDED INTO FOUR HORIZONTAL PORTIONS: THE TOP AND BOTTOM PORTIONS ARE BLUE AND THE MIDDLE TWO PORTIONS ARE GREEN. THE MIDDLE GREEN PORTIONS OF THE CIRCLE ARE UNEVENLY STACKED, WHILE THE TOP AND BOTTOM PORTIONS ARE EVENLY STACKED. THIS CIRCULAR MARK STANDS DIRECTLY BESIDE THE BLUE LETTERS "PELA". THE BLUE WORD "GEOENVIRONMENTAL" IS LOCATED DIRECTLY BELOW THE BLUE WORD "PELA" AND IS IN A SMALLER FONT THAT THE BLUE WORD "PELA" TO ACCOMMODATE THE LARGER AMOUNT OF LETTERS IN THE WORD "GEOENVIRONMENTAL" THAN IN THE WORD "PELA".

FOR TECHNICAL CONSULTANCY IN THE FIELD OF ENVIRONMENTAL SCIENCE (U.S. CLS. 100 AND 101).

FIRST USE 6-19-2010; IN COMMERCE 6-19-2010.

DOMINICK J. SALEMI, EXAMINING ATTORNEY

THE MARK CONSISTS OF STANDARD CHARACTERS WITHOUT CLAIM TO ANY PARTICULAR FONT, STYLE, SIZE, OR COLOR.

FOR COMMERCIAL ART DESIGN; COMPUTER AIDED DESIGN FOR OTHERS; COMPUTER AIDED GRAPHIC DESIGN; COMPUTER SITE DESIGN; CONSULTING SERVICES IN THE FIELD OF DESIGN OF NEWSLETTERS; CREATING AND DESIGNING WEB PAGES FOR OTHERS; CREATING, DESIGNING AND MAINTAINING WEB SITES; CREATION, DESIGN, DEVELOPMENT AND MAINTENANCE OF WEB SITES FOR THIRD PARTIES; DESIGN AND CREATING WEB SITES FOR OTHERS; DESIGN AND DEVELOPMENT OF VISUALIZATION TECHNOLOGIES FOR ADVERTISEMENT OF REAL-ESTATE, COMMERCIAL PRODUCT AND BUSINESS OF OTHERS; DESIGN AND MAINTENANCE OF WEB SITES FOR OTHERS; DESIGN AND TESTING FOR NEW PRODUCT DEVELOPMENT; DESIGN AND TESTING OF NEW PRODUCTS FOR OTHERS; DESIGN OF HOME PAGES, COMPUTER SOFTWARE AND WEB SITES; DESIGN OF HOMEPAGES AND WEBSITES; DESIGNING AND DEVELOPING WEBPAGES ON THE INTERNET; DESIGNING WEBSITES FOR ADVERTISING PURPOSES; DEVELOPMENT, DESIGN AND UPDATING OF HOME PAGES; GRAPHIC ART DESIGN; GRAPHIC ARTS DESIGNING; GRAPHIC DESIGN; GRAPHIC DESIGN SERVICES; INDUSTRIAL AND GRAPHIC ART DESIGN; INDUSTRIAL DESIGN; INDUSTRIAL DESIGN SERVICES; NEW PRODUCT DESIGN SERVICES; PACKAGING DESIGN; PACKAGING DESIGN FOR OTHERS; PROVIDING GRAPHIC AND MULTIMEDIA DESIGN SERVICES FOR THE PURPOSE OF PROMOTING THE GOODS AND SERVICES OF OTHERS (U.S. CLS. 100 AND 101).

FIRST USE 10-14-2010; IN COMMERCE 10-14-2010.

BRENDAN MCCAULEY, EXAMINING ATTORNEY

**CLASS 42—(Continued).**

SN 85-154,234. RATHWELL, ROB, VICTORIA, B.C., CANADA, FILED 10-15-2010.

**HOTTEST IN**

THE MARK CONSISTS OF STANDARD CHARACTERS WITHOUT CLAIM TO ANY PARTICULAR FONT, STYLE, SIZE, OR COLOR.

FOR COMPUTER SERVICES, NAMELY, CREATING ON-LINE LOCAL, REGIONAL AND NATIONAL COMMUNITIES FOR BOTH REGISTERED AND UNREGISTERED USERS TO (1) PARTICIPATE IN COMPETITIONS IN WHICH COMPETITORS ARE JUDGED BY USERS BY MAJORITY VOTE AS BEING THE BEST REPRESENTATIVE OF EACH RESPECTIVE COMMUNITY BASED ON THE COMPETITOR'S ATTRIBUTES; (2) SHOWCASE A COMPETITOR'S FAVORITE POSSESSIONS WITHIN DEFINED CATEGORIES AND HAVE USERS DETERMINE BY MAJORITY VOTE WHICH POSSESSIONS ARE BEST REPRESENTATIVES OF THEIR RESPECTIVE COMMUNITIES; AND (3) ENGAGE IN SOCIAL NETWORKING WITHIN THE BOUNDARIES OF THE SITE FOLLOWING RULES OF DECORUM AS SET BY A MODERATOR (U.S. CLS. 100 AND 101).

ELI HELLMAN, EXAMINING ATTORNEY

SN 85-154,390. OCTOPUS DESIGN GROUP, ALBANY, NY. FILED 10-16-2010.

**OCTOPUS**

THE MARK CONSISTS OF STANDARD CHARACTERS WITHOUT CLAIM TO ANY PARTICULAR FONT, STYLE, SIZE, OR COLOR.

FOR DESIGN AND TESTING OF NEW PRODUCTS FOR OTHERS; PACKAGING DESIGN FOR OTHERS; AND WEB SITE DESIGN FOR OTHERS (U.S. CLS. 100 AND 101).

FIRST USE 9-30-1998; IN COMMERCE 9-30-1998.  
REBECCA EISINGER, EXAMINING ATTORNEY

**CLASS 42—(Continued).**

SN 85-154,599. VILLAGESOUP, INC., ROCKLAND, ME. FILED 10-18-2010.

**DIGITAL MAIN STREET**

THE MARK CONSISTS OF STANDARD CHARACTERS WITHOUT CLAIM TO ANY PARTICULAR FONT, STYLE, SIZE, OR COLOR.

NO CLAIM IS MADE TO THE EXCLUSIVE RIGHT TO USE "DIGITAL", APART FROM THE MARK AS SHOWN.

FOR COMPUTER SERVICES, NAMELY, CREATING AND HOSTING ONLINE CONTENT MANAGEMENT SOFTWARE THAT ENABLES USERS TO UPLOAD, POST, DISPLAY, SHARE AND OTHERWISE PROVIDE VIA THE INTERNET ELECTRONIC MEDIA AND INFORMATION RELATED TO THEIR LOCAL COMMUNITIES (U.S. CLS. 100 AND 101).

BENJAMIN OKEKE, EXAMINING ATTORNEY

SN 85-154,845. PERATA, LINDA, PARK CITY, UT. FILED 10-18-2010.



NO CLAIM IS MADE TO THE EXCLUSIVE RIGHT TO USE "MORGELLONS", APART FROM THE MARK AS SHOWN.

THE COLOR(S) PINK, ORANGE, SILVER, AND BLACK IS/ARE CLAIMED AS A FEATURE OF THE MARK.

THE MARK CONSISTS OF OF A PINK AND ORANGE ECHINACEA FLOWER AND THE STYLIZED WORDS "MORGELLONS SANCTUM" IN SILVER WITH BLACK OUTLINES.

FOR HOSTING AN ON-LINE COMMUNITY WEB SITE FEATURING SUPPORT FOR LYME AND MORGELLONS DISEASE (U.S. CLS. 100 AND 101).

APRIL HESIK, EXAMINING ATTORNEY

SN 85-156,115. KARAMEL INTERNATIONAL CORP., OLD BRIDGE, NJ. FILED 10-19-2010.

**ASSET ALLOCATION -  
BALANCING - COMMITMENT**

THE MARK CONSISTS OF STANDARD CHARACTERS WITHOUT CLAIM TO ANY PARTICULAR FONT, STYLE, SIZE, OR COLOR.

NO CLAIM IS MADE TO THE EXCLUSIVE RIGHT TO USE "ASSET ALLOCATION", APART FROM THE MARK AS SHOWN.

FOR PROVIDING ON-LINE NON-DOWNLOADABLE SOFTWARE FOR FINANCIAL ANALYSIS (U.S. CLS. 100 AND 101).

LINDSEY RUBIN, EXAMINING ATTORNEY

**CLASS 42—(Continued).**

SN 85-156,446. CHI MEDIA GROUP, LLC, LAS VEGAS, NV.  
FILED 10-19-2010.



NO CLAIM IS MADE TO THE EXCLUSIVE RIGHT TO USE ".COM", APART FROM THE MARK AS SHOWN.

THE MARK CONSISTS OF THE WORDS "JUST CAN'T HANDLE" ENCLOSED IN A CAMOUFLAGE STYLE RECTANGULAR BORDER; A CAMOUFLAGE STYLE STAR SHAPE ABOVE AND TO THE LEFT SIDE OF THE RECTANGULAR BORDER, AND THE TERM ".COM" BELOW AND TO THE RIGHT SIDE OF THE RECTANGULAR BORDER.

FOR PROVIDING A WEB SITE THAT GIVES COMPUTER USERS THE ABILITY TO UPLOAD, EXCHANGE AND SHARE PHOTOS, VIDEOS AND VIDEO LOGS; PROVIDING A WEBSITE THAT GIVES COMPUTER USERS THE ABILITY TO VIEW, UPLOAD, POST, DISPLAY, TAG, AND SHARE USER-GENERATED AUDIO CLIPS, VIDEO CLIPS, PHOTOGRAPHS, AND WRITTEN MATERIAL ON A WIDE VARIETY OF TOPICS AND SUBJECTS (U.S. CLS. 100 AND 101).

YAT SYE, LEE, EXAMINING ATTORNEY

SN 85-156,766. DEVERGRANNE, THIEBAUT, PARIS, FRANCE, FILED 10-20-2010.

## Legiscope

THE MARK CONSISTS OF STANDARD CHARACTERS WITHOUT CLAIM TO ANY PARTICULAR FONT, STYLE, SIZE, OR COLOR.

FOR PROVIDING ON-LINE NON-DOWNLOADABLE SOFTWARE FOR USE IN LEGAL CASE MANAGEMENT, NAMELY, WORD PROCESSING, LEGAL BILLING, AND EMAIL REMINDER SOFTWARE WHICH ALLOWS USERS TO MANAGE CLIENT LEADS AND DEVELOPMENT, MANAGE AND ORGANIZE CLIENT MATTERS, TRACK TIME SPENT ON INDIVIDUAL CLIENT MATTERS, CREATE BILLS FOR CLIENTS, AND MANAGE THE BILLING PROCESS (U.S. CLS. 100 AND 101).

FIRST USE 2-1-2010; IN COMMERCE 2-1-2010.  
JIM RINGLE, EXAMINING ATTORNEY

**CLASS 42—(Continued).**

SN 85-156,816. KOLONOSKIE, KERIN, ARLINGTON, VA.  
FILED 10-20-2010.

## DESIGN SIREN

THE MARK CONSISTS OF STANDARD CHARACTERS WITHOUT CLAIM TO ANY PARTICULAR FONT, STYLE, SIZE, OR COLOR.

NO CLAIM IS MADE TO THE EXCLUSIVE RIGHT TO USE "DESIGN", APART FROM THE MARK AS SHOWN.

FOR GRAPHIC DESIGN SERVICES (U.S. CLS. 100 AND 101).

FIRST USE 1-14-2002; IN COMMERCE 1-14-2002.  
MATTHEW KLINE, EXAMINING ATTORNEY

SN 85-156,921. WESTAMERICA GRAPHICS CORPORATION, FOOTHILL RANCH, CA. FILED 10-20-2010.



NO CLAIM IS MADE TO THE EXCLUSIVE RIGHT TO USE "STOREFRONT", APART FROM THE MARK AS SHOWN.

THE MARK CONSISTS OF THE STYLIZED WORDING "STORFRONT" WITH A HORIZONTAL LINE APPEARING ABOVE THE "O" APPEARING NEXT TO AN ABSTRACT DESIGN OF A STOREFRONT AS REPRESENTED BY THREE QUADRILATERALS AND AN OPEN DOOR.

FOR PROVIDING TEMPORARY USE OF A WEB-BASED SOFTWARE APPLICATION FOR USE IN PRINT-ON-DEMAND AND PRODUCT ORDER FULFILLMENT (U.S. CLS. 100 AND 101).

FIRST USE 2-1-2010; IN COMMERCE 2-1-2010.  
CHRISTINE MARTIN, EXAMINING ATTORNEY

SN 85-157,362. SHENZHEN SUPER PERFECT OPTICS LIMITED, SHENZHEN, GUANGDONG, CHINA, FILED 10-20-2010.



THE COLOR(S) BLACK, BLUE, PURPLE AND GRAY IS/ ARE CLAIMED AS A FEATURE OF THE MARK.

THE MARK CONSISTS OF THE STYLIZED WORDING "SUPER" IN THE COLOR BLACK AND A STYLIZED LETTER "D", WHERE THE LEFT UPRIGHT PORTION OF THE MARK IS IN THE COLOR BLUE, THE TOP RIGHT ARC OF THE LETTER IS IN THE COLOR PURPLE, AND THE BOTTOM RIGHT PORTION IS IN THE COLOR GRAY.

FOR UPDATING OF COMPUTER SOFTWARE FOR OTHERS (U.S. CLS. 100 AND 101).

JAY BESCH, EXAMINING ATTORNEY

**CLASS 42—(Continued).**

SN 85-157,410. SHENZHEN SUPER PERFECT OPTICS LIMITED, SHENZHEN, GUANGDONG, CHINA, FILED 10-20-2010.



THE COLOR(S) BLUE, PURPLE AND GRAY IS/ARE CLAIMED AS A FEATURE OF THE MARK.

THE MARK CONSISTS OF A STYLIZED LETTER "D", WHERE THE LEFT UPRIGHT PORTION OF THE MARK IS IN THE COLOR BLUE, THE TOP RIGHT ARC OF THE LETTER IS IN THE COLOR PURPLE, AND THE BOTTOM RIGHT PORTION IS IN THE COLOR GRAY.

FOR UPDATING OF COMPUTER SOFTWARE FOR OTHERS (U.S. CLS. 100 AND 101).  
JAY BESCH, EXAMINING ATTORNEY

---

SN 85-157,426. MAXPOINT INTERACTIVE, INC., CARY, NC. FILED 10-20-2010.

**DIGITAL ZIP**

THE MARK CONSISTS OF STANDARD CHARACTERS WITHOUT CLAIM TO ANY PARTICULAR FONT, STYLE, SIZE, OR COLOR.

NO CLAIM IS MADE TO THE EXCLUSIVE RIGHT TO USE "DIGITAL", APART FROM THE MARK AS SHOWN.

FOR PROVIDING ONLINE NON-DOWNLOADABLE SOFTWARE FOR USE IN TARGETED ONLINE ADVERTISING (U.S. CLS. 100 AND 101).

KATHY DE JONGE, EXAMINING ATTORNEY

---

SN 85-157,699. MANILLA, LLC, NEW YORK, NY. FILED 10-21-2010.

**EFFORTLESS ORGANIZATION**

THE MARK CONSISTS OF STANDARD CHARACTERS WITHOUT CLAIM TO ANY PARTICULAR FONT, STYLE, SIZE, OR COLOR.

NO CLAIM IS MADE TO THE EXCLUSIVE RIGHT TO USE "ORGANIZATION", APART FROM THE MARK AS SHOWN.

FOR PROVIDING A WEB SITE FEATURING TECHNOLOGY THAT ENABLES USERS TO ORGANIZE AND MANAGE PERSONAL ACCOUNT DATA, INCLUDING HOUSEHOLD BILLS, FINANCES, TRAVEL REWARDS PROGRAMS, AND SUBSCRIPTIONS (U.S. CLS. 100 AND 101).

SEAN CROWLEY, EXAMINING ATTORNEY

**CLASS 42—(Continued).**

SN 85-157,836. ELEMENT MARKETING GROUP, NEW-TOWN, CT. FILED 10-21-2010.

**Element Access**

THE MARK CONSISTS OF STANDARD CHARACTERS WITHOUT CLAIM TO ANY PARTICULAR FONT, STYLE, SIZE, OR COLOR.

NO CLAIM IS MADE TO THE EXCLUSIVE RIGHT TO USE "ACCESS", APART FROM THE MARK AS SHOWN.

FOR PROVIDING TEMPORARY USE OF A WEB-BASED SOFTWARE APPLICATION FOR THE PHARMACEUTICAL INDUSTRY TO TRACK MANAGED CARE PHARMACEUTICAL REIMBURSEMENT AND MARKETING INFORMATION RELATED SPECIFICALLY TO A GIVEN BRAND (U.S. CLS. 100 AND 101).

ELLEN B. AWRICH, EXAMINING ATTORNEY

---

SN 85-157,959. JESSICA DOLAN, DBA ROOM TO BREATHE HOME ORGANIZING & STAGING, LLC, BELLEFONTE, PA. FILED 10-21-2010.

**Room to Breathe**

THE MARK CONSISTS OF STANDARD CHARACTERS WITHOUT CLAIM TO ANY PARTICULAR FONT, STYLE, SIZE, OR COLOR.

FOR HOME STAGING CONSULTATION, NAMELY, TEMPORARY INTERIOR AND EXTERIOR HOME DECORATION CONSULTATION FOR THE PURPOSE OF MAKING HOMES MORE APPEALING TO PROSPECTIVE BUYERS (U.S. CLS. 100 AND 101).

FIRST USE 10-1-2004; IN COMMERCE 10-1-2004.  
REBECCA GILBERT, EXAMINING ATTORNEY

**CLASS 42—(Continued).**

SN 85-158,042. COLDMAN, LLC, NEW YORK, NY. FILED 10-21-2010.

VOYr

THE MARK CONSISTS OF STANDARD CHARACTERS WITHOUT CLAIM TO ANY PARTICULAR FONT, STYLE, SIZE, OR COLOR.

FOR COMPUTER SERVICES, NAMELY, PROVIDING SEARCH PLATFORMS TO ALLOW USERS TO REQUEST CONTENT FROM AND RECEIVE CONTENT TO A MOBILE DEVICE OR COMPUTER; PROVIDING A MEMBERS-ONLY INTERNET AND MOBILE WEBSITE FEATURING TECHNOLOGY THAT ALLOWS MEMBERS TO VIEW, ACCESS, SHARE, AND PARTICIPATE IN DISCUSSIONS ABOUT INTERACTIVE FEATURES, BEHIND-THE-SCENES FOOTAGE AND OTHER AUDIO AND VIDEO EXCLUSIVE OFFERINGS PERTAINING TO MUSICAL ARTISTS AND PERFORMERS, ATHLETES, CELEBRITIES AND OTHER ENTERTAINERS (U.S. CLS. 100 AND 101).

KIMBERLY FRYE, EXAMINING ATTORNEY

SN 85-158,055. LOGMEIN, INC., WOBURN, MA. FILED 10-21-2010.

JOIN.ME

THE MARK CONSISTS OF STANDARD CHARACTERS WITHOUT CLAIM TO ANY PARTICULAR FONT, STYLE, SIZE, OR COLOR.

FOR PROVIDING ONLINE, NON-DOWNLOADABLE SOFTWARE FOR WEB-BASED SCREEN SHARING THAT ALLOWS SIMULTANEOUS AND ASYNCHRONOUS VIEWING, REMOTE CONTROL OF A COMPUTER, DOCUMENT SHARING, FILE TRANSFERRING, INSTANT MESSAGING, AUDIO CONFERENCING AND VIDEO CONFERENCING (U.S. CLS. 100 AND 101).

LINDA LAVACHE, EXAMINING ATTORNEY

**CLASS 42—(Continued).**

SN 85-158,106. COLDMAN, LLC, NEW YORK, NY. FILED 10-21-2010.

VOYR

THE MARK CONSISTS OF STANDARD CHARACTERS WITHOUT CLAIM TO ANY PARTICULAR FONT, STYLE, SIZE, OR COLOR.

FOR COMPUTER SERVICES, NAMELY, PROVIDING SEARCH PLATFORMS TO ALLOW USERS TO REQUEST CONTENT FROM AND RECEIVE CONTENT TO A MOBILE DEVICE OR COMPUTER; PROVIDING A MEMBERS-ONLY INTERNET AND MOBILE WEBSITE FEATURING TECHNOLOGY THAT ALLOWS MEMBERS TO VIEW, ACCESS, SHARE, AND PARTICIPATE IN DISCUSSIONS ABOUT INTERACTIVE FEATURES, BEHIND-THE-SCENES FOOTAGE AND OTHER AUDIO AND VIDEO EXCLUSIVE OFFERINGS PERTAINING TO MUSICAL ARTISTS AND PERFORMERS, ATHLETES, CELEBRITIES AND OTHER ENTERTAINERS (U.S. CLS. 100 AND 101).

KIMBERLY FRYE, EXAMINING ATTORNEY

SN 85-158,196. COLDMAN, LLC, NEW YORK, NY. FILED 10-21-2010.



THE COLOR(S) RED AND WHITE IS/ARE CLAIMED AS A FEATURE OF THE MARK.

THE MARK CONSISTS OF THE WORD "VOYR" IN WHITE LETTERS WITH THE "O" APPEARING IN A SPIRAL PATTERN ALL ON A RED BACKGROUND WITH A WHITE SHADOW OF LINKED AND OVERLAPPING "O'S" APPEARING BELOW THE WORD "VOYR".

FOR COMPUTER SERVICES, NAMELY, PROVIDING SEARCH PLATFORMS TO ALLOW USERS TO REQUEST CONTENT FROM AND RECEIVE CONTENT TO A MOBILE DEVICE OR COMPUTER; PROVIDING A MEMBERS-ONLY INTERNET AND MOBILE WEBSITE FEATURING TECHNOLOGY THAT ALLOWS MEMBERS TO VIEW, ACCESS, SHARE, AND PARTICIPATE IN DISCUSSIONS ABOUT INTERACTIVE FEATURES, BEHIND-THE-SCENES FOOTAGE AND OTHER AUDIO AND VIDEO EXCLUSIVE OFFERINGS PERTAINING TO MUSICAL ARTISTS AND PERFORMERS, ATHLETES, CELEBRITIES AND OTHER ENTERTAINERS (U.S. CLS. 100 AND 101).

KIMBERLY FRYE, EXAMINING ATTORNEY

**CLASS 42—(Continued).**

SN 85-158,349. 4D PEEK A BOO BABY LLC, ST. MICHAEL, MN. FILED 10-21-2010.

**CLASS 42—(Continued).**

SN 85-158,852. UNDERWRITERS LABORATORIES INC., NORTHBROOK, IL. FILED 10-22-2010.

**BELLA ANGEL IMAGING**

**PROACTIVE CUSTOMER ENGAGEMENT**

THE MARK CONSISTS OF STANDARD CHARACTERS WITHOUT CLAIM TO ANY PARTICULAR FONT, STYLE, SIZE, OR COLOR.

NO CLAIM IS MADE TO THE EXCLUSIVE RIGHT TO USE "IMAGING", APART FROM THE MARK AS SHOWN. THE ENGLISH TRANSLATION OF THE WORD "BELLA" IN THE MARK IS "BEAUTIFUL".

FOR PRENATAL ELECTRONIC IMAGING OF ULTRASOUNDS FOR NON-MEDICAL PURPOSES (U.S. CLS. 100 AND 101).

FIRST USE 12-0-2008; IN COMMERCE 12-0-2008. FONG HSU, EXAMINING ATTORNEY

THE MARK CONSISTS OF STANDARD CHARACTERS WITHOUT CLAIM TO ANY PARTICULAR FONT, STYLE, SIZE, OR COLOR.

NO CLAIM IS MADE TO THE EXCLUSIVE RIGHT TO USE "CUSTOMER ENGAGEMENT", APART FROM THE MARK AS SHOWN.

FOR PROVIDING TECHNICAL BUSINESS SERVICES, NAMELY, TESTING, ANALYSIS AND INSPECTION OF PRODUCTS OF OTHERS TO REDUCE LATE DISCOVERY OF PRODUCT PROBLEMS, MEET PRODUCT LAUNCH DATES AND REDUCE PRODUCT LAUNCH COSTS (U.S. CLS. 100 AND 101).

CHRIS WELLS, EXAMINING ATTORNEY

SN 85-158,633. SHIH, STEFANIE, CALABASAS, CA. FILED 10-22-2010.

SN 85-159,474. CHINA INSTITUTE IN AMERICA, NEW YORK, NY. FILED 10-22-2010.

**DoBand**

**CHINA360**

THE MARK CONSISTS OF STANDARD CHARACTERS WITHOUT CLAIM TO ANY PARTICULAR FONT, STYLE, SIZE, OR COLOR.

FOR COMPUTER SERVICES, NAMELY, CREATING AN ON-LINE COMMUNITY FOR REGISTERED USERS TO PARTICIPATE IN DISCUSSIONS, GET FEEDBACK FROM THEIR PEERS, FORM VIRTUAL COMMUNITIES, AND ENGAGE IN SOCIAL NETWORKING; COMPUTER SERVICES, NAMELY, CREATING AN ON-LINE COMMUNITY FOR REGISTERED USERS TO PARTICIPATE IN DISCUSSIONS, GET FEEDBACK FROM THEIR PEERS, FORM VIRTUAL COMMUNITIES, AND ENGAGE IN SOCIAL NETWORKING FEATURING SOCIAL AND/OR CHARITABLE CAUSES (U.S. CLS. 100 AND 101).

FIRST USE 2-23-2008; IN COMMERCE 2-23-2008. JEFFREY LOOK, EXAMINING ATTORNEY

THE MARK CONSISTS OF STANDARD CHARACTERS WITHOUT CLAIM TO ANY PARTICULAR FONT, STYLE, SIZE, OR COLOR.

OWNER OF U.S. REG. NO. 3,884,946. FOR COMPUTER SERVICES, NAMELY, CREATING AN ON-LINE COMMUNITY FOR REGISTERED USERS TO PARTICIPATE IN DISCUSSIONS, GET FEEDBACK FROM THEIR PEERS, FORM VIRTUAL COMMUNITIES, AND ENGAGE IN SOCIAL NETWORKING FEATURING TOPICS ABOUT CHINA AND THE CHINESE LANGUAGE AND CULTURE (U.S. CLS. 100 AND 101).

FIRST USE 4-26-2009; IN COMMERCE 4-26-2009. JAMES GRIFFIN, EXAMINING ATTORNEY

**CLASS 42—(Continued).**

SN 85-161,263. CORE EDUCATION AND CONSULTING SERVICES, INC., ATLANTA, GA. FILED 10-26-2010.

**CORE ECS UNIQUE ID**

THE MARK CONSISTS OF STANDARD CHARACTERS WITHOUT CLAIM TO ANY PARTICULAR FONT, STYLE, SIZE, OR COLOR.

OWNER OF U.S. REG. NOS. 3,350,913 AND 3,725,967.  
NO CLAIM IS MADE TO THE EXCLUSIVE RIGHT TO USE "UNIQUE ID", APART FROM THE MARK AS SHOWN.  
FOR COMPUTER SERVICES, NAMELY, PROVIDING ON-LINE NON-DOWNLOADABLE SOFTWARE ON A GLOBAL COMPUTER NETWORK FOR GENERATING UNIQUE STUDENT IDENTIFICATION TO TRACK STUDENT INFORMATION; DATA WAREHOUSING; AND COMPUTER SOFTWARE DEVELOPMENT (U.S. CLS. 100 AND 101).

EDWARD NELSON, EXAMINING ATTORNEY

---

SN 85-163,393. RIVERAIN MEDICAL GROUP, LLC, MIA-MISBURG, OH. FILED 10-28-2010.

**EMPHATIC**

THE MARK CONSISTS OF STANDARD CHARACTERS WITHOUT CLAIM TO ANY PARTICULAR FONT, STYLE, SIZE, OR COLOR.

FOR PRODUCT RESEARCH AND DEVELOPMENT (U.S. CLS. 100 AND 101).

TARAH HARDY, EXAMINING ATTORNEY

---

SN 85-169,188. OPEN-SENSE SOLUTIONS, LLC, HARTLAND, WI. FILED 11-4-2010.



THE COLOR(S) BLUE AND TEAL IS/ARE CLAIMED AS A FEATURE OF THE MARK.

THE MARK CONSISTS OF THE WORD "GROOVIX" WRITTEN IN THE COLOR BLUE IN ALL LOWER-CASE LETTERS, WITH A TEAL DOT ON THE "I".

FOR DESIGN, DEVELOPMENT AND IMPLEMENTATION OF SOFTWARE (U.S. CLS. 100 AND 101).

FIRST USE 2-1-2004; IN COMMERCE 10-1-2004.

HEATHER SAPP, EXAMINING ATTORNEY

**CLASS 42—(Continued).**

SN 85-172,550. LOGE, INC., TULSA, OK. FILED 11-9-2010.

**LogΣ**

THE MARK CONSISTS OF THE WORD LOG WITH A STYLIZED E IN THE FORM OF THE SIGMA CHARACTER.

FOR ENGINEER SERVICES IN THE FILED OF LOGISTIC AND RELIABILITY ENGINEERING; DATABASE DEVELOPMENT AND DESIGN; AUTOMATION SOFTWARE DESIGN AND DEVELOPMENT (U.S. CLS. 100 AND 101).

FIRST USE 2-1-2010; IN COMMERCE 2-1-2010.

PAUL E. FAHRENKOPF, EXAMINING ATTORNEY

---

SN 85-172,574. LOGE, INC., TULSA, OK. FILED 11-9-2010.

**OdysΣ**

THE MARK CONSISTS OF THE WORD ODYSSE WITH A STYLIZED E CONSISTING OF THE SIGMA CHARACTER.

FOR DATABASE DESIGN AND DEVELOPMENT (U.S. CLS. 100 AND 101).

FIRST USE 4-1-2010; IN COMMERCE 4-1-2010.

PAUL E. FAHRENKOPF, EXAMINING ATTORNEY



**CLASS 42—(Continued).**

SN 85-173,451. MCKENZIE, DANIEL, CAMERON PARK, CA.  
FILED 11-10-2010.

## Designing great experiences on purpose

THE MARK CONSISTS OF STANDARD CHARACTERS WITHOUT CLAIM TO ANY PARTICULAR FONT, STYLE, SIZE, OR COLOR.

FOR COMPUTER SOFTWARE DESIGN (U.S. CLS. 100 AND 101).

ARETHA SOMERVILLE, EXAMINING ATTORNEY

SN 85-174,450. ORION NETWORK SOLUTIONS, WILLIAMSBURG, VA. FILED 11-11-2010.

 The logo for Salesmob features the word "sales" in a grey, lowercase, sans-serif font, followed by "mob" in a bold, orange, lowercase, sans-serif font.

THE COLOR(S) SILVER AND ORANGE IS/ARE CLAIMED AS A FEATURE OF THE MARK.

THE MARK CONSISTS OF THE WORD "SALES" IN A SILVER COLOR AND "MOB" IN ORANGE WHICH IS DISPLAYED AS ONE WORD.

FOR APPLICATION SERVICE PROVIDER, NAMELY, HOSTING, MANAGING, DEVELOPING, AND MAINTAINING APPLICATIONS, SOFTWARE, AND WEB SITES, IN THE FIELDS OF PERSONAL PRODUCTIVITY, WIRELESS COMMUNICATION, MOBILE INFORMATION ACCESS, AND REMOTE DATAMANAGEMENT FOR WIRELESS DELIVERY OF CONTENT TO HANDHELD COMPUTERS, LAPTOPS AND MOBILE ELECTRONIC DEVICES (U.S. CLS. 100 AND 101).

FIRST USE 10-25-2010; IN COMMERCE 11-11-2010.  
CURTIS FRENCH, EXAMINING ATTORNEY

SN 85-174,590. INGENIOUS CROWDS, INC, NEW YORK, NY. FILED 11-11-2010.

 The logo for GeniusCrowds features a stylized icon of five human figures in blue and grey above the word "GeniusCrowds" in a blue, sans-serif font.

THE COLOR(S) GREY AND BLUE IS/ARE CLAIMED AS A FEATURE OF THE MARK.

THE MARK CONSISTS OF THE WORD "GENIUS" IN GREY AND "CROWDS" IN BLUE BELOW A DESIGN FEATURING FIVE FIGURES WHICH INCLUDES A BLUE FIGURE IN THE CENTER WITH TWO GREY FIGURES ON EACH SIDE WHICH ARE DECREASING IN HEIGHT.

FOR PRODUCT DEVELOPMENT (U.S. CLS. 100 AND 101).

FIRST USE 10-15-2010; IN COMMERCE 10-15-2010.  
COLLEEN KEARNEY, EXAMINING ATTORNEY

**CLASS 42—(Continued).**

SN 85-174,812. KICKSTARTER, INC., NEW YORK, NY.  
FILED 11-11-2010.

## KICKSTARTER

THE MARK CONSISTS OF STANDARD CHARACTERS WITHOUT CLAIM TO ANY PARTICULAR FONT, STYLE, SIZE, OR COLOR.

FOR COMPUTER SERVICES, NAMELY, CREATING AN ON-LINE PLATFORM FOR PRESALE AND FUNDRAISING FOR CREATIVE PROJECTS; HOSTING AN ON-LINE COMMUNITY WEB SITE FEATURING PEOPLE RAISING MONEY FOR CREATIVE PROJECTS; PROVIDING A WEB SITE FEATURING TECHNOLOGY THAT ENABLES USERS TO OFFER GOODS FOR PRESALE AND PLEDGE TO PURCHASE GOODS OFFERED BY OTHERS; PROVIDING A WEB SITE FEATURING TECHNOLOGY THAT ENABLES USERS TO RAISE MONEY FOR CREATIVE PROJECTS; PROVIDING A WEB SITE FEATURING TECHNOLOGY THAT ENABLES USERS TO OFFER GOODS AND SERVICES FOR PRESALE AND FOR USERS TO PLEDGE TO PURCHASE GOODS AND SERVICES OFFERED BY OTHERS; COMPUTER SERVICES, NAMELY, INTERACTIVE HOSTING SERVICES WHICH ALLOW THE USER TO PUBLISH AND SHARE THEIR OWN CONTENT AND IMAGES ON-LINE; PROVIDING AN ONLINE WEBSITE FOR CREATING AND HOSTING MICRO WEBSITES FOR BUSINESSES; PROVIDING A WEBSITE THAT GIVES USERS THE ABILITY TO PURCHASE DOWNLOADABLE MUSIC (U.S. CLS. 100 AND 101).

EMILY CHUO, EXAMINING ATTORNEY

SN 85-175,055. CLICKSTREAM MEDIA LLC, BROOKLYN, NY. FILED 11-11-2010.

## XFLOGGER

THE MARK CONSISTS OF STANDARD CHARACTERS WITHOUT CLAIM TO ANY PARTICULAR FONT, STYLE, SIZE, OR COLOR.

FOR PROVIDING A WEB SITE FEATURING TEMPORARY USE OF NON-DOWNLOADABLE SOFTWARE ALLOWING WEB SITE USERS TO UPLOAD ON-LINE VIDEOS FOR SHARING WITH OTHERS FOR ENTERTAINMENT PURPOSES (U.S. CLS. 100 AND 101).

MARK PILARO, EXAMINING ATTORNEY

**CLASS 42—(Continued).**

SN 85-175,700. COLMAN, DAVID IAN, SEATTLE, WA.  
FILED 11-12-2010.

## Human Cutouts

THE MARK CONSISTS OF STANDARD CHARACTERS WITHOUT CLAIM TO ANY PARTICULAR FONT, STYLE, SIZE, OR COLOR.

FOR COMPUTER SERVICES, NAMELY, CREATING AN ON-LINE COMMUNITY FOR REGISTERED USERS TO PARTICIPATE IN DISCUSSIONS, GET FEEDBACK FROM THEIR PEERS, FORM VIRTUAL COMMUNITIES, AND ENGAGE IN SOCIAL NETWORKING FEATURING PHOTOGRAPHIC AND MEDIA ORIENTED CONTENT; COMPUTER SERVICES IN THE NATURE OF CUSTOMIZED WEB PAGES FEATURING USER-DEFINED INFORMATION, SEARCH ENGINES AND ON-LINE WEB LINKS TO OTHER WEB SITES, PERSONAL PROFILES AND INFORMATION; PROVIDING TEMPORARY USE OF NON-DOWNLOADABLE SOFTWARE APPLICATIONS FOR MAINTAINING AND BUILDING WEB-PAGES IN THE FIELD OF CLASSIFIED AD LISTINGS, VIRTUAL COMMUNITY, SOCIAL NETWORKING, PHOTO SHARING, VIDEO SHARING, AND TRANSMISSION OF PHOTOGRAPHIC IMAGES; PEER-TO-BROWSER PHOTO SHARING SERVICES, NAMELY, PROVIDING A WEBSITE FEATURING TECHNOLOGY ENABLING USERS TO UPLOAD, VIEW, AND DOWNLOAD DIGITAL PHOTOS; PROVIDING A WEB SITE FEATURING TEMPORARY USE OF NON-DOWNLOADABLE SOFTWARE ALLOWING WEB SITE USERS TO UPLOAD, POST AND DISPLAY ONLINE VIDEOS FOR SHARING WITH OTHERS FOR ENTERTAINMENT PURPOSES (U.S. CLS. 100 AND 101).

CYNTHIA SLOAN, EXAMINING ATTORNEY

SN 85-176,046. ARIEL YVE DESIGN, LLC, OJAI, CA. FILED  
11-12-2010.

## Swipity

THE MARK CONSISTS OF STANDARD CHARACTERS WITHOUT CLAIM TO ANY PARTICULAR FONT, STYLE, SIZE, OR COLOR.

FOR COMPUTER SERVICES, NAMELY, CREATING AN ON-LINE COMMUNITY FOR REGISTERED USERS TO GET FEEDBACK FROM THEIR PEERS, FORM VIRTUAL COMMUNITIES, AND ENGAGE IN SOCIAL NETWORKING FEATURING PEOPLE CONNECTING WITH THEIR NEIGHBORS (U.S. CLS. 100 AND 101).

DOMINIC J. FERRAIUOLO, EXAMINING ATTORNEY

**CLASS 42—(Continued).**

SN 85-176,408. ILLUMAWARE, LLC, WAKE FOREST, NC.  
FILED 11-15-2010.

## ACES2PRINT

THE MARK CONSISTS OF STANDARD CHARACTERS WITHOUT CLAIM TO ANY PARTICULAR FONT, STYLE, SIZE, OR COLOR.

FOR PROVIDING TEMPORARY USE OF ON-LINE NONDOWNLOADABLE SOFTWARE AND APPLICATIONS FOR CREATING PRINT CATALOGUE LAYOUTS IN THE AUTOMOTIVE PARTS AFTERMARKET (U.S. CLS. 100 AND 101).

FIRST USE 6-0-2009; IN COMMERCE 6-0-2009.  
HANNO RITTNER, EXAMINING ATTORNEY

SN 85-176,410. ILLUMAWARE, LLC, WAKE FOREST, NC.  
FILED 11-15-2010.



NO CLAIM IS MADE TO THE EXCLUSIVE RIGHT TO USE "AFTERMARKET DATA", APART FROM THE MARK AS SHOWN.

THE MARK CONSISTS OF A BLOCK DESIGN TO THE LEFT SIDE OF THE WORDS "ILLUMAWARE AFTERMARKET DATA EXCELLENCE".

FOR PROVIDING TEMPORARY USE OF ON-LINE NONDOWNLOADABLE SOFTWARE AND APPLICATIONS FOR STANDARDIZED PARTS AND CATALOGUE DATA IN THE AUTOMOTIVE PARTS AFTERMARKET (U.S. CLS. 100 AND 101).

FIRST USE 3-16-2010, THE MARK WAS FIRST USED ANYWHERE IN A DIFFERENT FORM OTHER THAN THAT SOUGHT TO BE REGISTERED AT LEAST AS EARLY AS 07/02/2003.; IN COMMERCE 3-16-2010, THE MARK WAS FIRST USED IN COMMERCE IN A DIFFERENT FORM OTHER THAN THAT SOUGHT TO BE REGISTERED AT LEAST AS EARLY AS 07/02/2003..

HANNO RITTNER, EXAMINING ATTORNEY

**CLASS 42—(Continued).**

SN 85-176,413. ILLUMAWARE, LLC, WAKE FOREST, NC.  
FILED 11-15-2010.

**ACESADVANTAGE**

THE MARK CONSISTS OF STANDARD CHARACTERS WITHOUT CLAIM TO ANY PARTICULAR FONT, STYLE, SIZE, OR COLOR.

FOR PROVIDING TEMPORARY USE OF ON-LINE NONDOWNLOADABLE SOFTWARE AND APPLICATIONS FOR AUTOMATING DATA MAPPING FUNCTIONS FOR PARTS IN THE AUTOMOTIVE PARTS AFTERMARKET (U.S. CLS. 100 AND 101).

FIRST USE 8-0-2006; IN COMMERCE 8-0-2006.  
HANNO RITTNER, EXAMINING ATTORNEY

---

SN 85-176,414. ILLUMAWARE, LLC, WAKE FOREST, NC.  
FILED 11-15-2010.

**EVOKAT**

THE MARK CONSISTS OF STANDARD CHARACTERS WITHOUT CLAIM TO ANY PARTICULAR FONT, STYLE, SIZE, OR COLOR.

FOR PROVIDING TEMPORARY USE OF ON-LINE NONDOWNLOADABLE SOFTWARE AND APPLICATIONS FOR MONITORING STANDARDS COMPLIANCE IN THE AUTOMOTIVE PARTS AFTERMARKET (U.S. CLS. 100 AND 101).

FIRST USE 6-0-2006; IN COMMERCE 6-0-2006.  
HANNO RITTNER, EXAMINING ATTORNEY

---

SN 85-176,415. ILLUMAWARE, LLC, WAKE FOREST, NC.  
FILED 11-15-2010.

**MYCARPARTS**

THE MARK CONSISTS OF STANDARD CHARACTERS WITHOUT CLAIM TO ANY PARTICULAR FONT, STYLE, SIZE, OR COLOR.

FOR PROVIDING TEMPORARY USE OF ON-LINE NONDOWNLOADABLE SOFTWARE AND APPLICATIONS FOR CREATING ONLINE PARTS CATALOGUES IN THE AUTOMOTIVE PARTS AFTERMARKET (U.S. CLS. 100 AND 101).

FIRST USE 3-0-2007; IN COMMERCE 3-0-2007.  
HANNO RITTNER, EXAMINING ATTORNEY

**CLASS 42—(Continued).**

SN 85-177,117. THE ERP CONSULTING EXCHANGE, INC.,  
WINTER SPRINGS, FL. FILED 11-15-2010.

**ERPCX**

THE MARK CONSISTS OF STANDARD CHARACTERS WITHOUT CLAIM TO ANY PARTICULAR FONT, STYLE, SIZE, OR COLOR.

FOR COMPUTER CONSULTATION; COMPUTER HARDWARE AND SOFTWARE CONSULTING SERVICES; COMPUTER SOFTWARE CONSULTANCY; COMPUTER SOFTWARE CONSULTATION; COMPUTER SOFTWARE CONSULTING; COMPUTER SOFTWARE INSTALLATION AND MAINTENANCE; CONSULTING IN THE FIELD OF IT PROJECT MANAGEMENT; INFORMATION TECHNOLOGY CONSULTATION; INSTALLATION, MAINTENANCE AND REPAIR OF COMPUTER SOFTWARE; INSTALLATION, MAINTENANCE AND REPAIR OF SOFTWARE FOR COMPUTER SYSTEMS; INSTALLATION, REPAIR AND MAINTENANCE OF COMPUTER SOFTWARE; IT CONSULTING SERVICES; MAINTENANCE AND UPDATING OF COMPUTER SOFTWARE; MAINTENANCE AND UPGRADING OF COMPUTER SOFTWARE (U.S. CLS. 100 AND 101).

FIRST USE 1-1-2009; IN COMMERCE 1-1-2009.  
BARBARA A. GOLD, EXAMINING ATTORNEY

---

SN 85-177,601. SUSAN MARIE SANDERSON, DBA PROGRAMSELECT, VENICE, FL. FILED 11-16-2010.

**ProgramSelect**

THE MARK CONSISTS OF STYLIZED WORD PROGRAMSELECT.

FOR PROVIDING A WEB SITE FEATURING TECHNOLOGY THAT ENABLES USERS TO SUBMIT REVIEWS OF EXECUTIVE EDUCATION PROGRAMS (U.S. CLS. 100 AND 101).

PAUL MORENO, EXAMINING ATTORNEY

---

SN 85-178,186. DANA R MILLER, LEBANON, OH. FILED 11-16-2010.

**HOUSE\*TWEAKING**

THE MARK CONSISTS OF STANDARD CHARACTERS WITHOUT CLAIM TO ANY PARTICULAR FONT, STYLE, SIZE, OR COLOR.

FOR PROVIDING A WEBSITE FEATURING INFORMATION IN THE FIELD OF INTERIOR DESIGN AND ARCHITECTURE FOR USE BY INTERIOR DESIGNERS AND ARCHITECTS (U.S. CLS. 100 AND 101).

FIRST USE 11-18-2009; IN COMMERCE 11-18-2009.  
DOMINICK J. SALEMI, EXAMINING ATTORNEY

**CLASS 42—(Continued).**

SN 85-178,235. FLANEGIN, JAMES LELAND, SANTA CLARA, CA. FILED 11-16-2010.

# RockittRoom

THE MARK CONSISTS OF STANDARD CHARACTERS WITHOUT CLAIM TO ANY PARTICULAR FONT, STYLE, SIZE, OR COLOR.

FOR COMPUTER SERVICES, NAMELY, HOSTING ON-LINE WEB FACILITIES FOR OTHERS TO SHOW-CASE SONGWRITING AND MUSICAL TALENTS AND FOR FACILITATING AND CONDUCTING ONLINE CONNECTIONS, COLLABORATIONS, AND INTERACTIVE DISCUSSIONS ABOUT SONGWRITING AND MUSIC (U.S. CLS. 100 AND 101).

ARETHA SOMERVILLE, EXAMINING ATTORNEY

**CLASS 42—(Continued).**

SN 85-179,074. NUMIYO TECHNOLOGIES LLC, NAPLES, FL. FILED 11-17-2010.

# SHARE SUCCESSFULLY

THE MARK CONSISTS OF STANDARD CHARACTERS WITHOUT CLAIM TO ANY PARTICULAR FONT, STYLE, SIZE, OR COLOR.

FOR COMPUTER SERVICES, NAMELY, DESIGN AND BUILD WEB-BASED AND MOBILE APPLICATIONS FOR SOCIAL NETWORKS (U.S. CLS. 100 AND 101).

FIRST USE 12-30-2009; IN COMMERCE 12-30-2009.  
HEATHER BIDDULPH, EXAMINING ATTORNEY

SN 85-178,364. CHEMIN DE SAVOIR, INC., FORMERLY RUE DE SAVOIR, INC., LAS VEGAS, NV. FILED 11-16-2010.

# NoteStir

THE MARK CONSISTS OF STANDARD CHARACTERS WITHOUT CLAIM TO ANY PARTICULAR FONT, STYLE, SIZE, OR COLOR.

FOR COMPUTER SERVICES, NAMELY, HOSTING AND MAINTAINING AN ON-LINE WEB SITE FOR OTHERS TO FORM AN ON-LINE COMMUNITY, COMMUNICATE, SHARE NOTES, ANSWERS, FILES, PHOTOS, PROVIDE FEEDBACK ON PROFESSORS, COURSES, BOOKS, TESTS, AND EXAMS (U.S. CLS. 100 AND 101).

FIRST USE 10-12-2010; IN COMMERCE 10-12-2010.  
SANI KHOURI, EXAMINING ATTORNEY

SN 85-179,478. JOHN TADDIE ENTERPRISES, INC., LONG BEACH, CA. FILED 11-17-2010.

# Who's the Daddy? Ask Dr. Taddie!

THE MARK CONSISTS OF STANDARD CHARACTERS WITHOUT CLAIM TO ANY PARTICULAR FONT, STYLE, SIZE, OR COLOR.

THE NAME DR. TADDIE IDENTIFIES A LIVING INDIVIDUAL WHOSE CONSENT IS OF RECORD.

FOR DNA ANALYSIS SERVICES TO DETERMINE PATERNITY (U.S. CLS. 100 AND 101).

FIRST USE 9-13-2008; IN COMMERCE 1-1-2009.  
CAROL SPILS, EXAMINING ATTORNEY

SN 85-178,804. FAUST ASSOCIATES IN DESIGNED COMMUNICATIONS, LTD., RIVERSIDE, IL. FILED 11-17-2010.

# Appreciate It

THE MARK CONSISTS OF STANDARD CHARACTERS WITHOUT CLAIM TO ANY PARTICULAR FONT, STYLE, SIZE, OR COLOR.

FOR PROVIDING A WEB SITE FEATURING TECHNOLOGY THAT ENABLES INTERNET USERS TO SUBMIT COMMENTS OF PERSONAL RECOGNITION (U.S. CLS. 100 AND 101).

FIRST USE 11-11-2010; IN COMMERCE 11-11-2010.  
CAROLYN CATALDO, EXAMINING ATTORNEY

SN 85-179,489. GLASNER, ROY, VAN NUYS, CA. AND THIES, ERIC, VAN NUYS, CA. AND WISEMAN, BRENT, VAN NUYS, CA. FILED 11-17-2010.

# CLOCKWORK

THE MARK CONSISTS OF STANDARD CHARACTERS WITHOUT CLAIM TO ANY PARTICULAR FONT, STYLE, SIZE, OR COLOR.

FOR IT CONSULTING SERVICES; IT INTEGRATION SERVICES (U.S. CLS. 100 AND 101).

ELISSA GARBER KON, EXAMINING ATTORNEY

**CLASS 42—(Continued).**

SN 85-179,900. MARKETPATH, INC., INDIANAPOLIS, IN. FILED 11-18-2010.

**MARKETPATH**

THE MARK CONSISTS OF STANDARD CHARACTERS WITHOUT CLAIM TO ANY PARTICULAR FONT, STYLE, SIZE, OR COLOR.

FOR SOFTWARE AS A SERVICE (SAAS) SERVICES FEATURING SOFTWARE FOR THE MANAGEMENT AND MAINTENANCE OF WEB CONTENT; SOFTWARE AS A SERVICE (SAAS) SERVICES FEATURING SOFTWARE FOR THE MANAGEMENT OF E-COMMERCE ACTIVITY AND CUSTOMER RELATIONSHIPS; AND WEBSITE DESIGN, DEVELOPMENT, HOSTING AND MAINTENANCE FOR OTHERS (U.S. CLS. 100 AND 101).

FIRST USE 6-13-2006; IN COMMERCE 6-13-2006.  
CARYN GLASSER, EXAMINING ATTORNEY

**CLASS 42—(Continued).**

SN 85-180,744. TIMELINES, INC., CHICAGO, IL. FILED 11-19-2010.

**Photogram**

THE MARK CONSISTS OF STANDARD CHARACTERS WITHOUT CLAIM TO ANY PARTICULAR FONT, STYLE, SIZE, OR COLOR.

FOR PROVIDING A WEB SITE THAT GIVES USERS THE ABILITY TO CAPTURE, ORGANIZE, SEARCH, INDEX, STORE, SYNCHRONIZE, RECOGNIZE, SHARE, TRANSMIT AND DISPLAY DIGITAL FILES, INCLUDING AUDIO, VIDEO, TEXT, BINARY, STILL IMAGES, GRAPHICS, DIGITAL CONTENT AND MULTIMEDIA FILES (U.S. CLS. 100 AND 101).

DOMINIC J. FERRAIUOLO, EXAMINING ATTORNEY

SN 85-180,436. NELROD COMPANY, THE, FORT WORTH, TX. FILED 11-18-2010.

**Zebra Registrations A  
Service of The Nelrod  
Company**

THE MARK CONSISTS OF STANDARD CHARACTERS WITHOUT CLAIM TO ANY PARTICULAR FONT, STYLE, SIZE, OR COLOR.

OWNER OF U.S. REG. NOS. 2,825,669, 3,908,046 AND OTHERS.

NO CLAIM IS MADE TO THE EXCLUSIVE RIGHT TO USE "REGISTRATIONS" AND "A SERVICE OF" AND "COMPANY", APART FROM THE MARK AS SHOWN.

FOR APPLICATION SERVICE PROVIDER (ASP) FEATURING SOFTWARE FOR USE BY MEETING, CONFERENCE, WORKSHOP AND TRAINING PLANNERS TO ENROLL AND REGISTER PARTICIPANTS (U.S. CLS. 100 AND 101).

FIRST USE 11-18-2010; IN COMMERCE 11-18-2010.  
JAY FLOWERS, EXAMINING ATTORNEY

SN 85-181,662. XILLENT CORPORATION, SAN JOSE, CA. FILED 11-19-2010.

**Xillent**

THE MARK CONSISTS OF STANDARD CHARACTERS WITHOUT CLAIM TO ANY PARTICULAR FONT, STYLE, SIZE, OR COLOR.

FOR WEBSITE DESIGN AND DEVELOPMENT FOR OTHERS (U.S. CLS. 100 AND 101).

FIRST USE 11-7-2003; IN COMMERCE 11-7-2003.

RONALD MCMORROW, EXAMINING ATTORNEY

SN 85-180,449. ARIAGNO, CHRISTOPHER, BROOKLYN PARK, MN. FILED 11-18-2010.

**Audappcity**

THE MARK CONSISTS OF STANDARD CHARACTERS WITHOUT CLAIM TO ANY PARTICULAR FONT, STYLE, SIZE, OR COLOR.

FOR COMPUTER SOFTWARE DEVELOPMENT IN THE FIELD OF MOBILE APPLICATIONS (U.S. CLS. 100 AND 101).

WILLIAM ROSSMAN, EXAMINING ATTORNEY

SN 85-182,558. COMPANION CORPORATION, SALT LAKE CITY, UT. FILED 11-22-2010.



OWNER OF U.S. REG. NO. 2,924,062.

THE MARK CONSISTS OF THE WORD KEEPTRACK ADJACENT TO A NUMBER OF ARROWHEAD SHAPES ARRANGED IN A CIRCULAR PATTERN.

FOR PROVIDING ON-LINE NON-DOWNLOADABLE SOFTWARE FOR MONITORING, ANALYZING AND REPORTING FACILITY ENTRY AND EXIT OF INDIVIDUALS (U.S. CLS. 100 AND 101).

FIRST USE 7-7-2008; IN COMMERCE 7-7-2008.

DOMINIC J. FERRAIUOLO, EXAMINING ATTORNEY

**CLASS 42—(Continued).**

SN 85-182,908. PAWSLEY, LLC, NEW YORK, NY. FILED 11-22-2010.



THE MARK CONSISTS OF A STYLIZED DOG WEARING A COLLAR. TO THE RIGHT THERE IS THE STYLIZED TEXT "PAWSLEY EVERY DOG HAS ITS SAY".

FOR COMPUTER SERVICES, NAMELY, CREATING AN ON-LINE COMMUNITY FOR REGISTERED USERS TO PARTICIPATE IN DISCUSSIONS, GET FEEDBACK FROM THEIR PEERS, FORM VIRTUAL COMMUNITIES, AND ENGAGE IN SOCIAL NETWORKING FEATURING SOCIAL MEDIA AND TOPICS ON DOGS AND DOG-RELATED SERVICES AND ACCESSORIES (U.S. CLS. 100 AND 101).

FIRST USE 9-22-2010; IN COMMERCE 10-1-2010.  
MEGHAN REINHART, EXAMINING ATTORNEY

SN 85-192,770. RUSSELL, ALBERT, AUSTIN, TX. FILED 12-8-2010.

## SiteYour

THE MARK CONSISTS OF STANDARD CHARACTERS WITHOUT CLAIM TO ANY PARTICULAR FONT, STYLE, SIZE, OR COLOR.

FOR COMPUTER SITE DESIGN; CREATING AND DESIGNING WEB PAGES FOR OTHERS; CREATING, DESIGNING AND MAINTAINING WEB SITES; CREATION, DESIGN, DEVELOPMENT AND MAINTENANCE OF WEB SITES FOR THIRD PARTIES; DATABASE DESIGN AND DEVELOPMENT; DESIGN AND CREATING WEB SITES FOR OTHERS; DESIGN AND DEVELOPMENT OF INTEGRATED DATA COLLECTION AND WIRELESS TRANSMISSION HARDWARE SYSTEMS FOR EQUIPMENT AND FOR SOFTWARE APPLICATIONS ASSOCIATED WITH THAT EQUIPMENT AT MINING, CONSTRUCTION, AND INDUSTRIAL SITES; DESIGN AND DEVELOPMENT OF MULTIMEDIA PRODUCTS; DESIGN AND DEVELOPMENT OF NETWORKS; DESIGN AND DEVELOPMENT OF ON-LINE COMPUTER SOFTWARE SYSTEMS; DESIGN AND MAINTENANCE OF COMPUTER SITES FOR THIRD PARTIES; DESIGN AND MAINTENANCE OF WEB SITES FOR OTHERS; DESIGN OF COMPUTER DATABASE; DESIGN OF TRAFFIC CONTROL EQUIPMENT; DESIGN OF TRAFFIC SYSTEMS; DESIGN, CREATION, HOSTING AND MAINTENANCE OF INTERNET SITES FOR THIRD PARTIES; DESIGN, DEVELOPMENT AND IMPLEMENTATION OF SOFTWARE; DESIGN, DEVELOPMENT, AND CONSULTING SERVICES IN THE FIELD OF HOME AND WORKPLACE AUTOMATION HARDWARE AND SOFTWARE; DESIGNING THEME GRAPHICS AND MULTIMEDIA SHOWS FOR CONVENTIONS, PRODUCT LAUNCHES, TRADE SHOWS, KEY NOTE ADDRESSES AND AWARD CEREMONIES FOR OTHERS; DESIGNING WEBSITES FOR ADVERTISING PURPOSES; E-MAIL SYSTEM DESIGN AND IMPLEMENTATION FOR OTHERS; ELECTRONIC AND ELECTRICAL SYSTEMS DESIGN SERVICES; ENGINE RESTORATION DESIGN SERVICES; PACKAGING DESIGN; PACKAGING DESIGN FOR OTHERS; PLANNING, DESIGN AND IMPLEMENTATION OF VIRTUALIZATION TECHNOLOGIES FOR ENTER-

**CLASS 42—(Continued).**

PRISES AND BUSINESSES; PLANNING, DESIGN AND MANAGEMENT OF INFORMATION TECHNOLOGY SYSTEMS; PLANNING, DESIGN, DEVELOPMENT, MAINTENANCE AND OPTIMIZATION OF ONLINE WEBSITES FOR THIRD PARTIES; PROFESSIONAL COMPUTER SERVICES, NAMELY, NETWORK ANALYSIS, LAN/WAN DESIGN, WIRELESS ENGINEERING, VIRTUALIZATION AND COMPUTER PROJECT MANAGEMENT; PROVIDING A SECURED-ACCESS, MEMBERS ONLY WEBSITE FEATURING TECHNOLOGY THAT GIVES REGISTERED INTERNET NETWORKED DENTAL PROFESSIONALS THE ABILITY TO COMMUNICATE AND SHARE DATA FOR THE PURPOSES OF DESIGNING AND MANUFACTURING DENTAL RESTORATIONS; PROVIDING A WEBSITE FEATURING INFORMATION ABOUT GREEN ARCHITECTURE, INTERIOR DESIGN, SUSTAINABLE COMMUNITY PLANNING AND INFRASTRUCTURE DEVELOPMENT; PROVIDING A WEBSITE FEATURING INFORMATION IN THE FIELD OF INTERIOR DESIGN AND ARCHITECTURE FOR USE BY INTERIOR DESIGNERS AND ARCHITECTS; PROVIDING AN INTERNET WEBSITE PORTAL OFFERING INFORMATION IN THE FIELD OF COMPUTER AIDED DESIGN; PROVIDING DESIGN SERVICES FOR OTHERS IN THE FIELD OF THEME PARKS, MUSEUMS, AND MINIATURE GOLF COURSES; PROVIDING ENVIRONMENTALLY FRIENDLY AUTOMATION SOLUTIONS, NAMELY, SITE EVALUATIONS, CONTROL DESIGN ANALYSIS, AND INTEGRATED INSTALLATION SERVICES FOR MONITORING AND CONTROLLING RESPECTIVE INNOVATIVE DEVICES WITHIN A DESIGNATED AREA; PROVIDING GRAPHIC AND MULTIMEDIA DESIGN SERVICES FOR THE PURPOSE OF PROMOTING THE GOODS AND SERVICES OF OTHERS; RESEARCH, DEVELOPMENT, DESIGN AND UPGRADING OF COMPUTER SOFTWARE; ROOM DESIGN CONSISTING OF SELECTION OF ARTWORK, LIGHTING, AND FURNISHINGS FOR AN ENVIRONMENT DESIGNED TO HELP ACHIEVE MENTAL WELLNESS, INCLUDING STRESS MANAGEMENT AND RELAXATION, USING COMPUTER CONTROLLED ADVANCED SOUND WAVE TECHNOLOGY; SCIENTIFIC AND TECHNOLOGICAL SERVICES, NAMELY, RESEARCH AND DESIGN IN THE FIELD OF INTEGRATED SYSTEM ARCHITECTURE THAT ALLOWS FOR THE RAPID DEVELOPMENT OF HIGHLY INTERACTIVE AND CUSTOMIZABLE LEARNING APPLICATIONS; SERVICES FOR DESIGNING COMPUTER SOFTWARE; SET DESIGN FOR THEATRICAL ENTERPRISES; SHOP INTERIOR DESIGN; SOFTWARE DESIGN AND DEVELOPMENT; STRUCTURAL ENGINEERING DESIGN SERVICES; SURVEY DESIGN AND RESEARCH; TECHNICAL VERIFICATION OF POWER SYSTEMS DESIGNS; TOOL DESIGN; TOOL MANAGEMENT SYSTEMS DESIGN SERVICES; TRAFFIC DESIGN INTEGRATION; UPDATING AND DESIGN OF COMPUTER SOFTWARE; UPDATING, DESIGN AND RENTAL OF SOFTWARE; VISUAL DESIGN SERVICES IN THE NATURE OF DESIGNING VISUAL ELEMENTS FOR ON-LINE, BROADCAST, PRINT, OUTDOOR AND OTHER COMMUNICATION MEDIA; WEB SITE DESIGN; WEBSITE DESIGN AND DEVELOPMENT FOR OTHERS (U.S. CLS. 100 AND 101).

FIRST USE 5-3-2010; IN COMMERCE 5-3-2010.  
DAVID YONTEF, EXAMINING ATTORNEY

**CLASS 42—(Continued).**

SN 85-198,991. UNIVERSAL UNDERSTANDING, INC., JACKSONVILLE, FL. FILED 12-15-2010.

**Quality of Experience**

THE MARK CONSISTS OF STANDARD CHARACTERS WITHOUT CLAIM TO ANY PARTICULAR FONT, STYLE, SIZE, OR COLOR.

FOR INFORMATION TECHNOLOGY CONSULTATION; IT INTEGRATION SERVICES (U.S. CLS. 100 AND 101).

FIRST USE 11-12-2010; IN COMMERCE 11-12-2010.  
JIM RINGLE, EXAMINING ATTORNEY

**CLASS 42—(Continued).**

SN 85-221,510. QRI GROUP, LLC, HOUSTON, TX. FILED 1-19-2011.

**ERA**

THE MARK CONSISTS OF STANDARD CHARACTERS WITHOUT CLAIM TO ANY PARTICULAR FONT, STYLE, SIZE, OR COLOR.

FOR SERVICES IN THE FIELD OF EFFICIENT EXTRACTION OF HYDROCARBON RESOURCES, NAMELY, PROVIDING CONSULTING SERVICES TO OTHERS IN THE NATURE OF COMPILING AND ANALYZING CRITICAL INFORMATION COVERING OIL AND GAS RESERVOIRS, NAMELY, FORMATION PROPERTIES, GEOLOGIC ATTRIBUTES, PRODUCTION HISTORIES, WELL DESIGN DETAILS AND PRODUCTION FACILITIES FORMATION, AND UTILIZING RESERVOIR MANAGEMENT METRICS, ANALYTICAL TOOLS, AND KNOWLEDGE MANAGEMENT INSTRUMENTS TO GUIDE THE DIAGNOSTIC AND IMPLEMENTATION PHASES OF OPTIMIZING THE EFFICIENT EXTRACTION OF HYDROCARBON RESOURCES FROM RESERVOIRS OF OTHERS (U.S. CLS. 100 AND 101).

TEJBIR SINGH, EXAMINING ATTORNEY

SN 85-208,956. ALLSTATE INSURANCE COMPANY, NORTHBROOK, IL. FILED 1-3-2011.

**STREET SLEUTH**

THE MARK CONSISTS OF STANDARD CHARACTERS WITHOUT CLAIM TO ANY PARTICULAR FONT, STYLE, SIZE, OR COLOR.

FOR SOFTWARE IN THE NATURE OF A NON-DOWNLOADABLE INTERNET APPLICATION FOR EDUCATING THE USER ABOUT THE DANGERS OF DISTRACTED DRIVING (U.S. CLS. 100 AND 101).

ZACHARY BELLO, EXAMINING ATTORNEY

SN 85-975,104. RESEARCH PANEL ASIA INC., SHIBUYA, TOKYO, JAPAN, FILED 4-21-2010.

**Research Panel ASIA**

SN 85-218,382. DISRUPTIVEAPPS, INCORPORATED, BEVERLY, MA. FILED 1-14-2011.

**DISRUPTIVEAPPS**

THE MARK CONSISTS OF STANDARD CHARACTERS WITHOUT CLAIM TO ANY PARTICULAR FONT, STYLE, SIZE, OR COLOR.

FOR COMPUTER SOFTWARE SERVICES, NAMELY, THE DESIGN, DEVELOPMENT AND MANAGEMENT OF SOFTWARE AS A SERVICE (SAAS) PLATFORMS IN THE FIELD OF COMPUTER SOFTWARE APPLICATIONS, SMARTPHONE APPLICATIONS AND OTHER WIRELESS SOFTWARE APPLICATIONS (U.S. CLS. 100 AND 101).

FLORENTINA BLANDU, EXAMINING ATTORNEY

NO CLAIM IS MADE TO THE EXCLUSIVE RIGHT TO USE "ASIA", APART FROM THE MARK AS SHOWN.

THE MARK CONSISTS OF THE WORDS "RESEARCH PANEL" IN UPPER AND LOWERCASE LETTERS AND THE WORD "ASIA" IN ALL UPPERCASE LETTERS WITH A DOWNWARDLY-CURVED, PROGRESSIVELY-SHADED LINE DESIGN ELEMENT RUNNING THROUGH THE WORD "ASIA".

FOR CREATING AND UPDATING WEBSITES FOR OTHERS; PROVIDING INFORMATION CONCERNING THE CREATION OF WEBSITES; CREATING, DESIGNING AND MAINTAINING WEBSITES; PROVIDING INTERNET SEARCH ENGINES; DESIGNING COMPUTER SOFTWARE; COMPUTER PROGRAMMING; MAINTAINING COMPUTER SOFTWARE; RENTING COMPUTERS; PROVIDING ON-LINE NON-DOWNLOADABLE SOFTWARE FOR COLLECTING AND MANAGING INFORMATION FROM REGISTERED MEMBERS FOR CLIENT COMPANIES (U.S. CLS. 100 AND 101).

BARBARA GAYNOR, EXAMINING ATTORNEY

**CLASS 43—HOTEL AND RESTAURANT SERVICES**

SN 77-585,760. THE SIMPLE SKILLET, LLC, GILROY, CA. FILED 10-5-2008.



THE COLOR(S) BLACK, YELLOW AND GREEN IS/ARE CLAIMED AS A FEATURE OF THE MARK.

THE MARK CONSISTS OF A BLACK OUTLINED DRAWING OF A SKILLET WITH BRIGHT GREEN AND BRIGHT YELLOW OVALS INSIDE OF THE IMAGE WITH THE WORDS "THE SIMPLE SKILLET" UNDERNEATH THE DRAWING IN BLACK.

FOR CONSULTANCY SERVICES IN THE FIELD OF MENU PLANNING FOR OTHERS (U.S. CLS. 100 AND 101).

KRISTIN DAHLING, EXAMINING ATTORNEY

SN 77-596,987. STEPHEN POPOVICH, MURFEEBORO, TN. FILED 10-21-2008.

**MAMA LOOCHIES**

THE MARK CONSISTS OF STANDARD CHARACTERS WITHOUT CLAIM TO ANY PARTICULAR FONT, STYLE, SIZE, OR COLOR.

THE NAME(S), PORTRAIT(S), AND/OR SIGNATURE(S) SHOWN IN THE MARK DOES NOT IDENTIFY A PARTICULAR LIVING INDIVIDUAL.

FOR BAR AND RESTAURANT SERVICES (U.S. CLS. 100 AND 101).

MICHAEL GAAFAR, EXAMINING ATTORNEY

SN 77-713,445. LANDMARK VENTURES, LLC, DBA MARIO'S FISHBOWL LLC, MORGANTOWN, WV. FILED 4-14-2009.



NO CLAIM IS MADE TO THE EXCLUSIVE RIGHT TO USE "MORGANTOWN, WV", APART FROM THE MARK AS SHOWN.

THE NAME(S), PORTRAIT(S), AND/OR SIGNATURE(S) SHOWN IN THE MARK DOES NOT IDENTIFY A PARTICULAR LIVING INDIVIDUAL.

THE MARK CONSISTS OF THE WORD "MARIO'S" IN A SEMI-CIRCLE SHAPE DIRECTLY ABOVE A GOBLET CONTAINING A FISH BLOWING BUBBLES, THE GOBLET

**CLASS 43—(Continued).**

SERVING AS THE LETTER "O" IN THE WORD "FISHBOWL" WHICH RUNS IN LINE WITH THE GOBLET, BENEATH THE WORD "MARIO'S", THE DOT IN THE LETTER "I" AND THE CIRCLE PART OF THE LETTER "B" IN "FISHBOWL" BEING PARTLY REMOVED AS THOUGH BITTEN OFF, WITH THREE PARALLEL LINES OF INCREASING WIDTH RUNNING BENEATH THE WORD "FISHBOWL" BROKEN BY THE GOBLET AND THE WORDS "MORGANTOWN, WV" BEING BETWEEN THE TOP AND SECOND LINES.

FOR BAR AND RESTAURANT SERVICES; CARRY-OUT RESTAURANTS; RESTAURANT; RESTAURANT AND BAR SERVICES; RESTAURANT SERVICES; RESTAURANT SERVICES, INCLUDING SIT-DOWN SERVICE OF FOOD AND TAKE-OUT RESTAURANT SERVICES; RESTAURANT SERVICES, NAMELY, PROVIDING OF FOOD AND BEVERAGES FOR CONSUMPTION ON AND OFF THE PREMISES; TAKE-OUT RESTAURANT SERVICES (U.S. CLS. 100 AND 101).

FIRST USE 3-31-1997, THE MARK WAS FIRST USED ANYWHERE IN A DIFFERENT FORM OTHER THAN THAT SOUGHT TO BE REGISTERED AT LEAST AS EARLY AS 07/31/1963.; IN COMMERCE 3-31-1997, THE MARK WAS FIRST USED IN COMMERCE IN A DIFFERENT FORM OTHER THAN THAT SOUGHT TO BE REGISTERED AT LEAST AS EARLY AS 07/31/1963..

LINDA ESTRADA, EXAMINING ATTORNEY

SN 77-713,453. LANDMARK VENTURES, LLC, DBA MARIO'S FISHBOWL LLC, MORGANTOWN, WV. FILED 4-14-2009.



NO CLAIM IS MADE TO THE EXCLUSIVE RIGHT TO USE "BAR & GRILL", APART FROM THE MARK AS SHOWN.

THE NAME(S), PORTRAIT(S), AND/OR SIGNATURE(S) SHOWN IN THE MARK DOES NOT IDENTIFY A PARTICULAR LIVING INDIVIDUAL.

THE COLOR(S) RED, YELLOW-GOLD, WHITE AND GREEN IS/ARE CLAIMED AS A FEATURE OF THE MARK.

THE MARK CONSISTS OF THE WORD "MARIO'S" IN RED SHAPED IN A SEMI-CIRCLE OVER TOP OF A YELLOW/GOLD GOBLET CONTAINING A RED FISH WITH LARGE WHITE EYES AND WHITE LIPS APPARENTLY BLOWING WHITE BUBBLES, WITH THE WORD "FISHBOWL" IN GREEN DIRECTLY BENEATH THE GOBLET, WITH THE DOT OVER THE "I" AND THE CIRCLE PARTS OF THE LETTERS "B" AND "O" IN THE WORD "FISHBOWL" BEING PARTLY REMOVED AS IF BITTEN OFF, AND A RED LINE UNDERSCORING THE WORD "FISHBOWL", WITH THE WORDS "BAR & GRILL" IN RED BELOW THE LINE.

FOR BAR AND RESTAURANT SERVICES; CARRY-OUT RESTAURANTS; RESTAURANT; RESTAURANT AND BAR SERVICES; RESTAURANT SERVICES; RESTAURANT SERVICES, INCLUDING SIT-DOWN SERVICE OF FOOD AND TAKE-OUT RESTAURANT SERVICES; RESTAURANT SERVICES, NAMELY, PROVIDING OF FOOD AND BEVERAGES FOR CONSUMPTION ON AND OFF THE PREMISES; TAKE-OUT RESTAURANT SERVICES (U.S. CLS. 100 AND 101).

FIRST USE 3-31-1997, THE MARK WAS FIRST USED ANYWHERE IN A DIFFERENT FORM OTHER THAN THAT SOUGHT TO BE REGISTERED AT LEAST AS EARLY AS 07/31/1963; IN COMMERCE 3-31-1997, THE MARK WAS FIRST USED IN COMMERCE IN A DIFFERENT FORM OTHER THAN THAT SOUGHT TO BE REGISTERED AT LEAST AS EARLY AS 07/31/1963.

LINDA ESTRADA, EXAMINING ATTORNEY



**CLASS 43—(Continued).**

SN 77-850,209. H.T. CAFE LTD, JAMAICA, NY. FILED 10-16-2009.



NO CLAIM IS MADE TO THE EXCLUSIVE RIGHT TO USE "ISTANBUL/NEW YORK SUPERIOR FOOD", APART FROM THE MARK AS SHOWN.

THE COLOR(S) BLACK, WHITE, RED, BLUE, BEIGE, AND GRAY IS/ARE CLAIMED AS A FEATURE OF THE MARK.

THE MARK CONSISTS OF A WINKING CHEF IN BEIGE WITH A BLACK MUSTACHE, WHITE TEETH, AND OUTLINING IN BLACK WITH A WHITE CHEF HAT WITH BLACK HIGHLIGHTS AND OUTLINING SUPERIMPOSED AGAINST A RED CIRCLE WITH BLACK AND BLUE OUTLINING AND THE WORDS "EAT&GO" IN BLACK, AND "ISTANBUL/NEW YORK" AND "SUPERIOR FOOD BY DESSERTIST" IN GRAY SURROUNDING THE CIRCLE DESIGN.

FOR RESTAURANT SERVICES (U.S. CLS. 100 AND 101).

FIRST USE 10-1-2008; IN COMMERCE 10-1-2008.  
DEIRDRE ROBERTSON, EXAMINING ATTORNEY

**CLASS 43—(Continued).**

SN 78-958,985. KAHALA FRANCHISE CORP., SCOTTS-DALE, AZ. FILED 8-23-2006.



OWNER OF U.S. REG. NOS. 2,053,309, 2,615,016 AND 3,090,044.

NO CLAIM IS MADE TO THE EXCLUSIVE RIGHT TO USE "TERIYAKI GRILL", APART FROM THE MARK AS SHOWN.

THE MARK CONSISTS OF AN IMAGE OF A SAMURAI WARRIOR HOLDING A BOWL. THE SAMURAI IMAGE IS ENCLOSED WITHIN A CIRCLE, LOCATED TO THE LEFT OF THE WORDS "SAMURAI SAM'S TERIYAKI GRILL." THE WORDS "SAMURAI SAM'S" APPEAR IN STYLIZED LETTERING, AND THE WORDS "TERIYAKI GRILL" APPEAR IN ALL CAPITALIZED BLOCK LETTERING BENEATH THE WORDS "SAMURAI SAM'S".

FOR RESTAURANT SERVICES (U.S. CLS. 100 AND 101).

FIRST USE 7-5-2005; IN COMMERCE 7-5-2005.  
KAREN SEVERSON, EXAMINING ATTORNEY

SN 78-916,763. LUCAS OIL PRODUCTS, INC., CORONA, CA. FILED 6-26-2006.



NO CLAIM IS MADE TO THE EXCLUSIVE RIGHT TO USE "STADIUM", APART FROM THE MARK AS SHOWN.

THE COLOR(S) BLUE, RED, GRAY, BLACK AND WHITE IS/ARE CLAIMED AS A FEATURE OF THE MARK.

THE MARK CONSISTS OF THE STADIUM DESIGN IN GRAY WITH WHITE WINDOWS, THE LINE ON THE ROOF OF THE STADIUM AND THE BANNER ARE BLUE, THE WORDS "LUCAS OIL" ARE IN RED WITH BLACK BORDERS AND THE WORD "STADIUM" AND THE DIAMOND DESIGNS INSIDE THE BLUE BANNER ARE WHITE.

FOR ARENA SERVICES, NAMELY, PROVIDING FACILITIES FOR SPORTS, CONCERTS, CONVENTIONS AND EXHIBITIONS (U.S. CLS. 100 AND 101).

JENNY PARK, EXAMINING ATTORNEY

SN 79-082,858. SUN@FOOD CO., LTD., SEOUL, 135-894, REPUBLIC OF KOREA, FILED 4-27-2010.



PRIORITY DATE OF 3-25-2010 IS CLAIMED.  
OWNER OF INTERNATIONAL REGISTRATION 1039595 DATED 4-27-2010, EXPIRES 4-27-2020.

NO CLAIM IS MADE TO THE EXCLUSIVE RIGHT TO USE "FOOD" AND "GLOBAL DINING LEADER", APART FROM THE MARK AS SHOWN.

THE COLOR(S) RED, ORANGE, YELLOW AND BLACK IS/ARE CLAIMED AS A FEATURE OF THE MARK.

THE MARK CONSISTS OF THE BLACK WORDING "SUN AT FOOD GLOBAL DINING LEADER" BELOW A STYLIZED GLOBE SHOWN IN A RED VERTICAL CURVED LINE, TWO UPPER ORANGE HORIZONTAL CURVED LINES AND TWO LOWER YELLOW HORIZONTAL CURVED LINES. THE COLOR WHITE APPEARS AS BACKGROUND AND DOES NOT FORM PART OF THE MARK.

FOR CANTEN SERVICES; CAFE SERVICES; RESTAURANT SERVICES; SELF-SERVICE RESTAURANTS (U.S. CLS. 100 AND 101).

TRACY FLETCHER, EXAMINING ATTORNEY

**CLASS 43—(Continued).**

SN 85-000,501. SARPONG, JUNE, LONDON, ENGLAND, FILED 3-29-2010.

**NEWSDISH**

THE MARK CONSISTS OF STANDARD CHARACTERS WITHOUT CLAIM TO ANY PARTICULAR FONT, STYLE, SIZE, OR COLOR.

FOR PROVIDING A WEBSITE CONTAINING RECIPES AND ADVICE IN THE FIELD OF COOKING (U.S. CLS. 100 AND 101).

WENDY GOODMAN, EXAMINING ATTORNEY

---

SN 85-015,358. FROSTY FROG CREAMERY, INC., CANTON, GA. FILED 4-15-2010.

**FROSTY FROG**

THE MARK CONSISTS OF STANDARD CHARACTERS WITHOUT CLAIM TO ANY PARTICULAR FONT, STYLE, SIZE, OR COLOR.

FOR ICE CREAM SHOP SERVICES IN THE NATURE OF A RESTAURANT; RESTAURANT SERVICES (U.S. CLS. 100 AND 101).

FIRST USE 5-11-2002; IN COMMERCE 5-11-2002.  
JERI J. FICKES, EXAMINING ATTORNEY

---

SN 85-021,277. FRESH-CO INVESTMENTS LLC, RIO RICO, AZ. FILED 4-22-2010.

**AQUA DREAM FROZEN YOGURT**

THE MARK CONSISTS OF STANDARD CHARACTERS WITHOUT CLAIM TO ANY PARTICULAR FONT, STYLE, SIZE, OR COLOR.

NO CLAIM IS MADE TO THE EXCLUSIVE RIGHT TO USE "FROZEN YOGURT", APART FROM THE MARK AS SHOWN.

FOR RESTAURANT SERVICES FEATURING SELF-SERVE FROZEN CONFECTIONS, FROZEN YOGURT, FROZEN CUSTARD, FROZEN YOGURT BARS, FROZEN YOGURT SMOOTHIES, FROZEN YOGURT ICE CREAM PIES; FROZEN YOGURT ICE CREAM CAKES, FROZEN YOGURT SHAKES AND FROZEN BEVERAGES, ALL WITH AND WITHOUT MIX-INS AND TOPPINGS (U.S. CLS. 100 AND 101).

TRACY WHITTAKER-BROWN, EXAMINING ATTORNEY

**CLASS 43—(Continued).**

SN 85-026,284. YETI DOGS, LLC, BIG SKY, MT. FILED 4-29-2010.



THE MARK CONSISTS OF A SNOWMAN. HIS PHYSIQUE IS SHORT AND ROUND WITH SHAGGY EDGES REPRESENTING A FURRY COAT. HE HAS SMALL OVAL EYES AND A TRAPEZOID MOUTH FULL OF TRIANGLE TEETH ARE HIS ONLY FACIAL FEATURES. HIS LEFT ARM IS FLEXING IN FRONT OF HIS BODY AND HIS RIGHT ARM IS HIDDEN BEHIND HIS BACK. HE STANDS ON SQUATTY ELEPHANT-LIKE FEET.

FOR RESTAURANT SERVICES (U.S. CLS. 100 AND 101).

FIRST USE 11-1-2007; IN COMMERCE 2-2-2008.

SETH A. RAPPAPORT, EXAMINING ATTORNEY

---

SN 85-032,548. KRAFT FOODS GLOBAL BRANDS LLC, NORTHFIELD, IL. FILED 5-7-2010.

**SK SOCIAL KITCHEN**

THE MARK CONSISTS OF STANDARD CHARACTERS WITHOUT CLAIM TO ANY PARTICULAR FONT, STYLE, SIZE, OR COLOR.

NO CLAIM IS MADE TO THE EXCLUSIVE RIGHT TO USE "KITCHEN", APART FROM THE MARK AS SHOWN.

FOR RESTAURANT SERVICES, INCLUDING SIT-DOWN SERVICE OF FOOD AND TAKE-OUT RESTAURANT SERVICES (U.S. CLS. 100 AND 101).

LINDSEY RUBIN, EXAMINING ATTORNEY

**CLASS 43—(Continued).**

SN 85-043,492. PUBLIC HOUSE INVESTMENTS, PHILADELPHIA, PA. FILED 5-20-2010.

**CLASS 43—(Continued).**

SN 85-046,299. WU, PHILIP, SAN GABRIEL, CA. AND LIU, DAN DAN, SAN GABRIEL, CA. FILED 5-24-2010.

**CITY TAP HOUSE**

THE MARK CONSISTS OF STANDARD CHARACTERS WITHOUT CLAIM TO ANY PARTICULAR FONT, STYLE, SIZE, OR COLOR.

NO CLAIM IS MADE TO THE EXCLUSIVE RIGHT TO USE "TAP HOUSE", APART FROM THE MARK AS SHOWN. FOR BAR AND RESTAURANT SERVICES (U.S. CLS. 100 AND 101).

FIRST USE 4-0-2010; IN COMMERCE 4-0-2010.  
SIMON TENG, EXAMINING ATTORNEY



SN 85-043,968. PUBLIC HOUSE INVESTMENTS, PHILADELPHIA, PA. FILED 5-20-2010.



NO CLAIM IS MADE TO THE EXCLUSIVE RIGHT TO USE "TAP HOUSE", APART FROM THE MARK AS SHOWN. FOR BAR AND RESTAURANT SERVICES (U.S. CLS. 100 AND 101).

FIRST USE 4-0-2010; IN COMMERCE 4-0-2010.  
SIMON TENG, EXAMINING ATTORNEY

NO CLAIM IS MADE TO THE EXCLUSIVE RIGHT TO USE "1989 RICE NOODLE" AND THE NON-LATIN CHARACTERS THAT TRANSLITERATE TO "GUI LIN MI FEN", APART FROM THE MARK AS SHOWN.

THE COLOR(S) BLACK, RED, MAROON, GREEN, AND PALE YELLOW IS/ARE CLAIMED AS A FEATURE OF THE MARK.

THE MARK CONSISTS OF THE IMAGE OF A GIRL DRESSED IN BLACK AND MAROON, WITH PALE-YELLOW BACKGROUND, SURROUNDED BY THE WORDING "DANDAN'S RICE NOODLE 1989" AND SIX CHINESE CHARACTERS, WHICH TRANSLITERATE TO DAN DAN GUI LIN MI FEN, WITH ALL WORDS IN PALE-YELLOW EXCEPT "1989" WHICH IS IN RED, WITH BLACK BACKGROUND. THE COLOR BLACK ALSO APPEARS IN THE HAIR, EYES, NOSE, AND EAR DESIGN OF THE GIRL. THE COLOR PALE YELLOW ALSO APPEARS IN THE FACE OF THE GIRL. THE BLACK CIRCLE IS SURROUNDED BY THREE OUTER CIRCLES IN THE COLORS PALE YELLOW, MAROON, AND GREEN, FROM INSIDE TO OUTSIDE.

THE NON-LATIN CHARACTERS IN THE MARK TRANSLITERATE TO DAN DAN GUI LIN MI FEN AND THIS MEANS "DAN DAN GUILIN STYLE RICE NOODLE" IN ENGLISH.

FOR BAR AND RESTAURANT SERVICES; CAFE AND RESTAURANT SERVICES; CAFE-RESTAURANTS; CAFETERIA AND RESTAURANT SERVICES; CARRY-OUT RESTAURANTS; RESTAURANT; RESTAURANT AND CAFE SERVICES; RESTAURANT AND CATERING SERVICES; RESTAURANT SERVICES; RESTAURANT SERVICES FEATURING SPECIALTY CHINESE FOOD; RESTAURANT SERVICES, INCLUDING SIT-DOWN SERVICE OF FOOD AND TAKE-OUT RESTAURANT SERVICES; RESTAURANT SERVICES, NAMELY, PROVIDING OF FOOD AND BEVERAGES FOR CONSUMPTION ON AND OFF THE PREMISES; RESTAURANTS (U.S. CLS. 100 AND 101).

FIRST USE 10-25-2006; IN COMMERCE 10-25-2006.  
ALEX KEAM, EXAMINING ATTORNEY

**CLASS 43—(Continued).**

SN 85-053,686. KINDERLAND PRESCHOOL AND DAY-CARE, MESA, AZ. FILED 6-3-2010.



THE MARK CONSISTS OF FOUR STYLIZED CHILDREN HOLDING HANDS TO THE LEFT OF THE TEXT "KINDERLAND".

THE WORDING "KINDERLAND" HAS NO MEANING IN A FOREIGN LANGUAGE.

FOR PRESCHOOLER AND INFANT CARE AT DAY-CARE CENTERS (U.S. CLS. 100 AND 101).

FIRST USE 4-1-2005; IN COMMERCE 4-1-2005.  
NELSON SNYDER, EXAMINING ATTORNEY

**CLASS 43—(Continued).**

SN 85-062,312. MEDICAL DIAGNOSTIC LABORATORIES, LLC, HAMILTON, NJ. FILED 6-14-2010.



SN 85-055,896. B HOTEL GROUP, LLC, WESTON, FL. FILED 6-7-2010.

# B HOTEL

THE MARK CONSISTS OF STANDARD CHARACTERS WITHOUT CLAIM TO ANY PARTICULAR FONT, STYLE, SIZE, OR COLOR.

NO CLAIM IS MADE TO THE EXCLUSIVE RIGHT TO USE "HOTEL", APART FROM THE MARK AS SHOWN.

FOR HOTEL, RESORT LODGING AND MOTEL SERVICES; RESTAURANT, CATERING, BAR AND COCKTAIL LOUNGE SERVICES; PROVISION OF GENERAL PURPOSE FACILITIES FOR MEETINGS, CONFERENCES AND EXHIBITIONS; PROVISION OF BANQUET AND SOCIAL FUNCTION FACILITIES FOR SPECIAL OCCASIONS; HOTEL SERVICES FOR PREFERRED CUSTOMERS; SPA SERVICES, NAMELY, PROVIDING TEMPORARY ACCOMMODATIONS AND MEALS TO CLIENTS OF A HEALTH OR BEAUTY SPA; AND RESERVATION SERVICES FOR HOTEL ACCOMMODATIONS FOR OTHERS (U.S. CLS. 100 AND 101).

LEIGH LOWRY, EXAMINING ATTORNEY

NO CLAIM IS MADE TO THE EXCLUSIVE RIGHT TO USE "CHOCOLATE CAFE", APART FROM THE MARK AS SHOWN.

THE MARK CONSISTS OF THE LITERAL ELEMENTS "ARTISSERIE" AND "CHOCOLATE CAFE". THE "A" IN THE WORD "ARTISSERIE" IS DEPICTED AS THE EIFFEL TOWER. A SHADOW IS DEPICTED BENEATH THE EIFFEL TOWER. CHOCOLATE IS DEPICTED FLOWING FROM THE TOP OF THE EIFFEL TOWER WHICH FORMS A BANNER ACROSS THE BOTTOM OF THE MARK. THE PHRASE "CHOCOLATE CAFE" IS CONTAINED WITHIN THE BANNER, AN ACCENT MARK IS DEPICTED ABOVE THE LETTER "E" IN THE WORD "CAFE". AN ARTIST'S PALETTE IS DEPICTED IN THE BACKGROUND. THE THUMB-HOLE OF THE PALETTE IS DEPICTED BY AN OVAL ABOVE THE LETTERS "SS" IN THE WORD "ARTISSERIE".

THE WORDING "ARTISSERIE" HAS NO MEANING IN A FOREIGN LANGUAGE.

FOR RESTAURANT AND CAFE SERVICES (U.S. CLS. 100 AND 101).

MYRIAH HABEEB, EXAMINING ATTORNEY

**CLASS 43—(Continued).**

SN 85-070,284. TERRA SUR CAFE OF TAMPA LLC, DBA TERRA SUR CAFE, TAMPA, FL. FILED 6-24-2010.



NO CLAIM IS MADE TO THE EXCLUSIVE RIGHT TO USE "CAFE", APART FROM THE MARK AS SHOWN.

THE MARK CONSISTS OF THE STYLIZED WORDING "TERRA SUR CAFE" WITHIN A RECTANGLE UNDERNEATH A LARGER RECTANGLE CONTAINING A STYLIZED DESIGN OF A SUN WITH A HUMAN FACE.

THE ENGLISH TRANSLATION OF "TERRA SUR" IN THE MARK IS "LAND SOUTH".

FOR CAFE; CAFE AND RESTAURANT SERVICES; CAFE-RESTAURANTS; CAFES; RESTAURANT AND CAFE SERVICES; RESTAURANT SERVICES FEATURING PERUVIAN CUISINE (U.S. CLS. 100 AND 101).

FIRST USE 8-1-2004; IN COMMERCE 8-1-2004.  
NICHOLAS ALTREE, EXAMINING ATTORNEY

**CLASS 43—(Continued).**

SN 85-075,788. MILLER, DAVID T., PALM CITY, FL. FILED 7-1-2010.



THE NAME(S), PORTRAIT(S), AND/OR SIGNATURE(S) SHOWN IN THE MARK DOES NOT IDENTIFY A PARTICULAR LIVING INDIVIDUAL.

THE MARK CONSISTS OF THE WORDS "MR. LAFF'S" DEPICTED IN A CURVED STYLIZED FONT AND THE LETTER "L" IN "LAFF'S" IS DEPICTED IN CURSIVE AND IN A LARGER FONT THAN THE REST OF THE LETTERS WITH THE BOTTOM PORTION OF THE "L" FORMING AN UNDERLINE OF THE LETTERS "AFF'S".

FOR RESTAURANT, BAR AND CATERING SERVICES (U.S. CLS. 100 AND 101).

ERIN FALK, EXAMINING ATTORNEY

SN 85-084,773. GLORIA FUENTES, AKA GLORIA RUBIO, DALLAS, TX. FILED 7-14-2010.



NO CLAIM IS MADE TO THE EXCLUSIVE RIGHT TO USE "RESTAURANTS", APART FROM THE MARK AS SHOWN.

THE COLOR(S) BLACK, RED, AND YELLOW IS/ARE CLAIMED AS A FEATURE OF THE MARK.

THE MARK CONSISTS OF A BLACK BOX WITH "GLORIA'S" IN CAPITAL RED LETTERS AND "RESTAURANTS" IN SMALL CAPITAL YELLOW LETTERS UNDERNEATH THE NAME "GLORIA'S".

FOR BAR AND RESTAURANT SERVICES (U.S. CLS. 100 AND 101).

FIRST USE 1-5-2010; IN COMMERCE 1-5-2010.  
BRENDAN REGAN, EXAMINING ATTORNEY

SN 85-072,305. WILLIS, PAUL, FORT WORTH, TX. FILED 6-26-2010.

BUFFALO GAP STEAKHOUSE & CANTINA

THE MARK CONSISTS OF STANDARD CHARACTERS WITHOUT CLAIM TO ANY PARTICULAR FONT, STYLE, SIZE, OR COLOR.

NO CLAIM IS MADE TO THE EXCLUSIVE RIGHT TO USE "STEAKHOUSE & CANTINA", APART FROM THE MARK AS SHOWN.

FOR RESTAURANT SERVICES, NAMELY, PROVIDING FOOD AND DRINK (U.S. CLS. 100 AND 101).

FIRST USE 1-1-2002; IN COMMERCE 4-15-2007.  
KIMBERLY PERRY, EXAMINING ATTORNEY

**CLASS 43—(Continued).**

SN 85-085,461. LHO GRAFTON HOTEL, L.P., BETHESDA, MD. FILED 7-15-2010.

## The Grafton On Sunset

THE MARK CONSISTS OF STANDARD CHARACTERS WITHOUT CLAIM TO ANY PARTICULAR FONT, STYLE, SIZE, OR COLOR.

OWNER OF U.S. REG. NO. 2,727,489.  
FOR HOTEL SERVICES (U.S. CLS. 100 AND 101).  
FIRST USE 2-1-2000; IN COMMERCE 2-1-2000.  
REBECCA SMITH, EXAMINING ATTORNEY

**CLASS 43—(Continued).**

SN 85-108,512. HILLSTONE RESTAURANT GROUP, INC., PHOENIX, AZ. FILED 8-16-2010.

## R+D KITCHEN

SN 85-087,898. JENKINS, RAE, SLC, UT. FILED 7-19-2010.

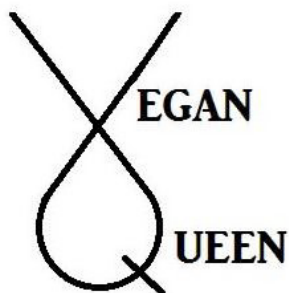

THE MARK CONSISTS OF STANDARD CHARACTERS WITHOUT CLAIM TO ANY PARTICULAR FONT, STYLE, SIZE, OR COLOR.

NO CLAIM IS MADE TO THE EXCLUSIVE RIGHT TO USE "KITCHEN", APART FROM THE MARK AS SHOWN.  
FOR RESTAURANT AND BAR SERVICES (U.S. CLS. 100 AND 101).

FIRST USE 9-16-2005; IN COMMERCE 9-16-2005.  
KELLY TRUSILO, EXAMINING ATTORNEY

NO CLAIM IS MADE TO THE EXCLUSIVE RIGHT TO USE "VEGAN", APART FROM THE MARK AS SHOWN.

THE MARK CONSISTS OF LINED DRAWING COMPRISING A STYLIZED EMBODIMENT OF THE WORDS "VEGAN QUEEN".

FOR CAFE AND RESTAURANT SERVICES; CAFE-RESTAURANTS; CARRY-OUT RESTAURANTS; FAST FOOD AND NON-STOP RESTAURANT SERVICES (U.S. CLS. 100 AND 101).

TEJBIR SINGH, EXAMINING ATTORNEY

SN 85-108,528. HILLSTONE RESTAURANT GROUP, INC., PHOENIX, AZ. FILED 8-16-2010.

## THE HONOR BAR

SN 85-092,907. HUDDLE HOUSE, INC., ATLANTA, GA. FILED 7-26-2010.

## HUDDLE HAPPY

THE MARK CONSISTS OF STANDARD CHARACTERS WITHOUT CLAIM TO ANY PARTICULAR FONT, STYLE, SIZE, OR COLOR.

OWNER OF U.S. REG. NOS. 903,628, 1,673,776 AND OTHERS.  
FOR RESTAURANT SERVICES (U.S. CLS. 100 AND 101).

FIRST USE 7-1-2010; IN COMMERCE 7-1-2010.  
AISHA SALEM, EXAMINING ATTORNEY

THE MARK CONSISTS OF STANDARD CHARACTERS WITHOUT CLAIM TO ANY PARTICULAR FONT, STYLE, SIZE, OR COLOR.

NO CLAIM IS MADE TO THE EXCLUSIVE RIGHT TO USE "BAR", APART FROM THE MARK AS SHOWN.  
FOR RESTAURANT AND BAR SERVICES (U.S. CLS. 100 AND 101).

FIRST USE 4-26-2010; IN COMMERCE 4-26-2010.  
KELLY TRUSILO, EXAMINING ATTORNEY

**CLASS 43—(Continued).**

SN 85-110,427. TK MANAGEMENT, LLC, YOUNTVILLE, CA. FILED 8-18-2010.



OWNER OF U.S. REG. NOS. 2,559,236, 3,874,072 AND OTHERS.

THE COLOR(S) TAN, BROWN, BURNT ORANGE, BLACK AND WHITE IS/ARE CLAIMED AS A FEATURE OF THE MARK.

THE MARK CONSISTS OF THE STYLIZED WORD "BOUCHON" IN TAN LETTERS OUTLINED IN BROWN ON A BURNT ORANGE RECTANGULAR BACKGROUND WITH THE BACKGROUND BORDERED ON TOP AND BOTTOM WITH A BLACK LINE, FOLLOWED BY A WHITE LINE WITH SMALL TAN SQUARES, FOLLOWED BY A BLACK LINE.

THE ENGLISH TRANSLATION OF THE FRENCH WORD "BOUCHON" IN THE MARK IS "A PLUG" OR "STOPPER", ALSO A "PLUG, ELECTRIC PLUG, STOPPER".

FOR RESTAURANT, BAR AND CATERING SERVICES AND PROVIDING BANQUET AND SOCIAL FUNCTION FACILITIES FOR SPECIAL OCCASIONS (U.S. CLS. 100 AND 101).

FIRST USE 10-14-1998; IN COMMERCE 10-14-1998.

TRACY WHITTAKER-BROWN, EXAMINING ATTORNEY

**CLASS 43—(Continued).**

SN 85-141,962. MAPLE VIEW HOLDINGS CORP., DBA CLINTON ST. BAKING CO., NEW YORK, NY. FILED 9-30-2010.



NO CLAIM IS MADE TO THE EXCLUSIVE RIGHT TO USE "BAKING COMPANY & RESTAURANT", APART FROM THE MARK AS SHOWN.

SEC. 2(F).

FOR CAFE AND RESTAURANT SERVICES; CARRY-OUT RESTAURANTS; RESTAURANT; RESTAURANT AND CATERING SERVICES; SELF SERVICE RESTAURANTS (U.S. CLS. 100 AND 101).

FIRST USE 4-1-2001; IN COMMERCE 4-1-2001.

FRANK LATTUCA, EXAMINING ATTORNEY

SN 85-141,995. KRAZE INTERNATIONAL, INC., GYEONGGI-DO, 471-857, REPUBLIC OF KOREA, FILED 9-30-2010.

SN 85-123,021. GREENWICH HOTEL RESTAURANT LLC, NEW YORK, NY. FILED 9-3-2010.

LOCANDA VERDE



THE MARK CONSISTS OF STANDARD CHARACTERS WITHOUT CLAIM TO ANY PARTICULAR FONT, STYLE, SIZE, OR COLOR.

NO CLAIM IS MADE TO THE EXCLUSIVE RIGHT TO USE "LOCANDA", APART FROM THE MARK AS SHOWN.

THE ENGLISH TRANSLATION OF "LOCANDA VERDE" IN THE MARK IS "GREEN INN".

FOR RESTAURANT AND BAR SERVICES (U.S. CLS. 100 AND 101).

FIRST USE 5-18-2009; IN COMMERCE 5-18-2009.

BRENDAN MCCAULEY, EXAMINING ATTORNEY

OWNER OF REPUBLIC OF KOREA REG. NO. 411998000768, DATED 9-22-1998, EXPIRES 8-13-2019.

NO CLAIM IS MADE TO THE EXCLUSIVE RIGHT TO USE "BURGERS", APART FROM THE MARK AS SHOWN.

THE MARK CONSISTS OF AN OVAL AROUND THE TERMS "EZARK", WHICH IS "KRAZE" WRITTEN BACKWARDS, AND "BURGERS".

FOR RESTAURANT SERVICES (U.S. CLS. 100 AND 101).

LEIGH CAROLINE CASE, EXAMINING ATTORNEY

**CLASS 43—(Continued).**

SN 85-143,119. PGA TOUR, INC., PONTE VEDRA BEACH, FL. FILED 10-1-2010.

PATRIOTS' OUTPOST

THE MARK CONSISTS OF STANDARD CHARACTERS WITHOUT CLAIM TO ANY PARTICULAR FONT, STYLE, SIZE, OR COLOR.

FOR HOSPITALITY SERVICES IN THE NATURE OF PROVIDING A HOSPITALITY TENT WITH COMPLIMENTARY FOOD AND BEVERAGES AND ALSO INCLUDING INTERACTIVE GAMING, TOURNAMENT PROGRAMS, AND GIVE-AWAYS FOR MILITARY PROFESSIONALS AND THEIR FAMILIES AT GOLF TOURNAMENTS (U.S. CLS. 100 AND 101).

FIRST USE 8-22-2008; IN COMMERCE 8-22-2008.  
TRICIA SONNEBORN, EXAMINING ATTORNEY

---

SN 85-145,377. FLOWERS AT BRICKELL KEY, INC., DBA THE JUICERY BAR, MIAMI BEACH, FL. FILED 10-5-2010.



NO CLAIM IS MADE TO THE EXCLUSIVE RIGHT TO USE "JUICERY BAR", APART FROM THE MARK AS SHOWN.

THE MARK CONSISTS OF "THE JUICERY BAR" IN SANS SERIF FONT WITH THE WORD "THE" WRITTEN VERTICALLY IN THE STEM OF THE "J" AND WITH "BAR" WRITTEN BENEATH "JUICERY". A ROW OF FOUR FRUIT IMAGES APPEAR ABOVE THE WORD "JUICERY". EACH FRUIT IMAGE IS SEPARATELY ENCIRCLED. THE FRUIT IMAGES FROM LEFT TO RIGHT ARE A CITRUS-FRUIT CROSS-SECTION, A KIWI CROSS SECTION, A CITRUS-FRUIT CROSS SECTION, AND A STRAWBERRY.

FOR CAFE AND RESTAURANT SERVICES; CAFE AND RESTAURANT SERVICES, NAMELY, RESTAURANTS AND CAFES SELLING FRESH JUICES, DRINKS, SMOOTHIES, COFFEE, YOGURT, AND FRUIT SALADS (U.S. CLS. 100 AND 101).

FIRST USE 3-29-2010; IN COMMERCE 3-29-2010.  
KATHLEEN LORENZO, EXAMINING ATTORNEY

**CLASS 43—(Continued).**

SN 85-145,451. TORRENEGRA IP, LLC, SECAUCUS, NJ. FILED 10-5-2010.

localo

THE MARK CONSISTS OF STANDARD CHARACTERS WITHOUT CLAIM TO ANY PARTICULAR FONT, STYLE, SIZE, OR COLOR.

FOR EXTENDED-STAY HOTELS; HOTEL ACCOMMODATION SERVICES; HOTEL SERVICES; MAKING HOTEL RESERVATIONS FOR OTHERS; PROVIDE A WEBSITE FOR MAKING RESERVATIONS AND BOOKING OF ECO-LODGING; PROVIDING ON-LINE REVIEWS OF RESTAURANTS AND HOTELS; PROVIDING TRAVEL LODGING INFORMATION SERVICES AND TRAVEL LODGING BOOKING AGENCY SERVICES FOR TRAVELERS; TRAVEL AGENCY SERVICES, NAMELY, MAKING RESERVATIONS AND BOOKING FOR TEMPORARY LODGING; TRAVEL AGENCY SERVICES, NAMELY, MAKING RESERVATIONS AND BOOKING FOR TEMPORARY LODGING FOR OTHER TRAVEL AGENCIES, TRAVEL SUPPLIERS, AND CORPORATIONS, VIA ON-LINE COMPUTER NETWORKS (U.S. CLS. 100 AND 101).

FIRST USE 10-1-2010; IN COMMERCE 10-5-2010.  
INGRID C. EULIN, EXAMINING ATTORNEY

---

SN 85-146,739. 416, LLC, RED BANK, NJ. FILED 10-6-2010.

PAZZO MMX

THE MARK CONSISTS OF STANDARD CHARACTERS WITHOUT CLAIM TO ANY PARTICULAR FONT, STYLE, SIZE, OR COLOR.

THE ENGLISH TRANSLATION OF "PAZZO" IN THE MARK IS "CRAZY".  
FOR RESTAURANT SERVICES (U.S. CLS. 100 AND 101).

FIRST USE 6-29-2010; IN COMMERCE 6-29-2010.  
ANNE E. GUSTASON, EXAMINING ATTORNEY



**CLASS 43—(Continued).**

SN 85-148,797. FUSE INVESTMENT GROUP, LLC, IRVING, TX. FILED 10-8-2010.



THE COLOR(S) YELLOW AND WHITE IS/ARE CLAIMED AS A FEATURE OF THE MARK.

THE MARK CONSISTS OF THE YELLOW WORDING "BRINGING THE BEST RESTAURANTS TO YOU" APPEARING ABOVE A YELLOW OVAL HAVING A YELLOW AND WHITE BORDER AND CONTAINING THE WORDING "CATERSERVE" IN WHITE. A SOLID YELLOW LINE EXTENDS FROM EACH SIDE OF THE OVAL.

FOR CATERING; CATERING FOR THE PROVISION OF FOOD AND BEVERAGES; CATERING OF FOOD AND DRINKS; CATERING SERVICES (U.S. CLS. 100 AND 101).

FIRST USE 3-1-2010; IN COMMERCE 3-1-2010.  
DEBRA LEE, EXAMINING ATTORNEY

**CLASS 43—(Continued).**

SN 85-153,114. ROLE MODEL LLC, RENO, NV. FILED 10-14-2010.



NO CLAIM IS MADE TO THE EXCLUSIVE RIGHT TO USE "CANTINA", APART FROM THE MARK AS SHOWN.

THE MARK CONSISTS OF THE WORDS "CANTINA LOS TRES HOMBRES" TO THE LEFT OF THE LOGO AND STACKED ON TOP OF EACH OTHER, STARTING WITH "CANTINA", THEN "LOS TRES", THEN "HOMBRES". THE LOGO CONSISTENT OF THREE GENTLEMEN UNDER ONE SOMBRERO. THE MAN TO THE LEFT IS SMOKING AND HAS A GOATEE. THE MAN IN THE CENTER HAS A MUSTACHE. THE MAN TO THE RIGHT HAS A MUSTACHE AND IS HOLDING A ROSE IN HIS MOUTH.

THE ENGLISH TRANSLATION OF "CANTINA LOS TRES HOMBRES" IS TAVERN OF THE THREE MEN. FOR RESTAURANT SERVICES (U.S. CLS. 100 AND 101).

FIRST USE 9-1-1987; IN COMMERCE 9-1-1987.  
DORITT L. CARROLL, EXAMINING ATTORNEY

SN 85-152,140. FIGARO'S ITALIAN PIZZA, INC., SALEM, OR. FILED 10-13-2010.

**SCHMIZZA PUB & GRUB**

THE MARK CONSISTS OF STANDARD CHARACTERS WITHOUT CLAIM TO ANY PARTICULAR FONT, STYLE, SIZE, OR COLOR.

OWNER OF U.S. REG. NOS. 2,346,972, 2,997,528 AND 3,215,625.

NO CLAIM IS MADE TO THE EXCLUSIVE RIGHT TO USE "PUB & GRUB", APART FROM THE MARK AS SHOWN.

FOR RESTAURANT SERVICES (U.S. CLS. 100 AND 101).

FIRST USE 10-28-2009; IN COMMERCE 10-28-2009.  
MARGERY A. TIERNEY, EXAMINING ATTORNEY

SN 85-153,738. MANESS, ANTHONY KEITH, FALLSTON, NC. FILED 10-15-2010.

**THE PEPPERONI EXPRESS PIZZA CO.**

THE MARK CONSISTS OF STANDARD CHARACTERS WITHOUT CLAIM TO ANY PARTICULAR FONT, STYLE, SIZE, OR COLOR.

NO CLAIM IS MADE TO THE EXCLUSIVE RIGHT TO USE "PIZZA CO.", APART FROM THE MARK AS SHOWN. FOR RESTAURANT SERVICES (U.S. CLS. 100 AND 101).

FIRST USE 12-2-2002; IN COMMERCE 12-2-2002.  
LINDA POWELL, EXAMINING ATTORNEY

**CLASS 43—(Continued).**

SN 85-154,388. GONDOLA GROUNDS COFFEE, LLC, DBA GONDOLA GROUNDS COFFEE, MOUNTAINVILLAGE, CO. FILED 10-16-2010.



NO CLAIM IS MADE TO THE EXCLUSIVE RIGHT TO USE "COFFEE" AND "TELLURIDE COLORADO", APART FROM THE MARK AS SHOWN.

THE COLOR(S) BLACK, WHITE, BROWN AND TAN IS/ARE CLAIMED AS A FEATURE OF THE MARK.

THE MARK CONSISTS OF A TAN OVAL WITH THE BLACK AND WHITE TEXT "GONDOLA GROUNDS COFFEE". IN THE MIDDLE OF THE OVAL IS A WHITE, BLACK AND TAN IMAGE OF A STEAMING COFFEE CUP, BETWEEN THE WORDS "TELLURIDE" AND "COLORADO" IN BROWN. BELOW THE COFFEE CUP IS THE SLOGAN "A REAL LIFT" IN BROWN.

FOR COFFEE AND JUICE BAR SERVICES; COFFEE AND TEA BARS; COFFEE SHOPS (U.S. CLS. 100 AND 101).

RÉBECCA EISINGER, EXAMINING ATTORNEY

**CLASS 43—(Continued).**

SN 85-154,788. O'NEILL-MILETO, MARGARET, DANBURY, CT. FILED 10-18-2010.

## Dog-Play USA

THE MARK CONSISTS OF STANDARD CHARACTERS WITHOUT CLAIM TO ANY PARTICULAR FONT, STYLE, SIZE, OR COLOR.

NO CLAIM IS MADE TO THE EXCLUSIVE RIGHT TO USE "USA", APART FROM THE MARK AS SHOWN.

FOR PET BOARDING SERVICES; PET DAY CARE SERVICES (U.S. CLS. 100 AND 101).

MICHAEL WEBSTER, EXAMINING ATTORNEY

SN 85-154,777. WINN, MICHAEL, DBA UNDERCLIFF BAR & GRILL, TIPTON FORD, MO. FILED 10-18-2010.



NO CLAIM IS MADE TO THE EXCLUSIVE RIGHT TO USE "GRILL & BAR TIPTON FORD, MO", APART FROM THE MARK AS SHOWN.

THE MARK CONSISTS OF THE WORD "UNDERCLIFF" WITH ANGLES RESEMBLING MOUNTAINS AND CLIFFS SET AT THE TOP OF THE LETTERS. UNDER THIS ARE THE WORDS "GRILL & BAR," UNDER THAT ARE THE WORDS "TIPTON FORD, MO".

FOR BAR AND RESTAURANT SERVICES (U.S. CLS. 100 AND 101).

FIRST USE 2-14-1995; IN COMMERCE 2-14-1995.  
MICHAEL WEBSTER, EXAMINING ATTORNEY



NO CLAIM IS MADE TO THE EXCLUSIVE RIGHT TO USE "ORGANIC BAKERY", APART FROM THE MARK AS SHOWN.

THE COLOR(S) GREEN AND BROWN IS/ARE CLAIMED AS A FEATURE OF THE MARK.

THE MARK CONSISTS OF A GREEN SQUIGGLY LINE APPROXIMATING THE SHAPE OF A CHEF'S HAT OR A KING'S CROWN AT THE TOP WITH FIVE BROWN STARS UNDER THE CROWN. THE WORDS "FIVE STAR FROGS ORGANIC BAKERY" APPEAR UNDER THE HAT OR CROWN ON THREE DIFFERENT LINES IN BROWN CAPITAL LETTERS.

FOR RESTAURANT AND CATERING SERVICES FEATURING ORGANIC INGREDIENTS (U.S. CLS. 100 AND 101).

ELLEN BURNS, EXAMINING ATTORNEY

**CLASS 43—(Continued).**

SN 85-155,451. YOGURT MAMA INC., HILLSBOROUGH, CA. FILED 10-18-2010.

# YOGURT MAMA

THE MARK CONSISTS OF STANDARD CHARACTERS WITHOUT CLAIM TO ANY PARTICULAR FONT, STYLE, SIZE, OR COLOR.

NO CLAIM IS MADE TO THE EXCLUSIVE RIGHT TO USE "YOGURT", APART FROM THE MARK AS SHOWN.

FOR FROZEN YOGURT SHOP SERVICES IN THE NATURE OF A RESTAURANT (U.S. CLS. 100 AND 101). FIRST USE 2-15-2009; IN COMMERCE 2-15-2009. ROBIN MITTLER, EXAMINING ATTORNEY

**CLASS 43—(Continued).**

SN 85-155,613. ADVINITI CORPORATION, AKA TEAWAY, SAN FRANCISCO, CA. FILED 10-19-2010.



NO CLAIM IS MADE TO THE EXCLUSIVE RIGHT TO USE "TEA", APART FROM THE MARK AS SHOWN.

THE COLOR(S) GREEN AND LIGHT BLUE IS/ARE CLAIMED AS A FEATURE OF THE MARK.

THE MARK CONSISTS OF THE STYLIZED WORDING "TEAWAY" WITH "TEA" APPEARING IN GREEN AND "WAY" APPEARING IN LIGHT BLUE.

FOR FAST-FOOD RESTAURANTS AND SNACKBARS (U.S. CLS. 100 AND 101).

FIRST USE 9-1-2009; IN COMMERCE 9-1-2009. RONALD MCMORROW, EXAMINING ATTORNEY

SN 85-155,913. PEANUTS WORLDWIDE LLC, NEW YORK, NY. FILED 10-19-2010.

# PROJECT LINUS

THE MARK CONSISTS OF STANDARD CHARACTERS WITHOUT CLAIM TO ANY PARTICULAR FONT, STYLE, SIZE, OR COLOR.

NO CLAIM IS MADE TO THE EXCLUSIVE RIGHT TO USE "PROJECT", APART FROM THE MARK AS SHOWN.

FOR CHARITABLE SERVICES, NAMELY, PROVIDING BLANKETS TO THOSE IN NEED (U.S. CLS. 100 AND 101).

FIRST USE 1-1-2001; IN COMMERCE 1-1-2001. JUDITH HELFMAN, EXAMINING ATTORNEY

SN 85-155,471. YOGURT MAMA INC., HILLSBOROUGH, CA. FILED 10-18-2010.



NO CLAIM IS MADE TO THE EXCLUSIVE RIGHT TO USE "YOGURT", APART FROM THE MARK AS SHOWN.

THE COLOR(S) ORANGE, TEAL, GREEN, PINK, BLACK AND WHITE IS/ARE CLAIMED AS A FEATURE OF THE MARK.

THE MARK CONSISTS OF "YO" AND "MAMA" IN ORANGE WITH WHITE OUTLINE, WITH "GURT" IN TEAL WITH WHITE OUTLINE; THE WORDS "YOGURT MAMA" ARE OUTLINED IN GREEN WITH A GREEN AND WHITE LEAF EXTENDING TO THE RIGHT OF THE WORDS; A PINK AND WHITE FLOWER IS IN THE LOWER LEFT OF THE MARK AND A GIRL'S HEAD IN BLACK AND WHITE WITH PINK TONGUE AND CHEEKS, WEARING A PINK AND WHITE BANDANA, IS IN THE UPPER RIGHT OF THE MARK. THE FLOWER IS OUTLINED IN GREEN AND THE GIRL AND BANDANNA ARE OUTLINED IN BLACK AND GREEN.

FOR FROZEN YOGURT SHOP SERVICES IN THE NATURE OF A RESTAURANT (U.S. CLS. 100 AND 101). FIRST USE 2-15-2009; IN COMMERCE 2-15-2009. ROBIN MITTLER, EXAMINING ATTORNEY

SN 85-156,040. RAFIK BAKIJAN, GLENDALE, CA. FILED 10-19-2010.



THE MARK CONSISTS OF A STYLIZED COMBINATION OF THE LETTERS "R" AND "P."

FOR RESTAURANT AND BAR SERVICES; RESTAURANT SERVICES, INCLUDING SIT-DOWN SERVICE OF FOOD AND TAKE-OUT RESTAURANT SERVICES (U.S. CLS. 100 AND 101).

FIRST USE 2-1-2010; IN COMMERCE 2-1-2010. COURTNEY ALVAREZ, EXAMINING ATTORNEY

**CLASS 43—(Continued).**

SN 85-156,975. RCS FOODS, LLC, KENNESAW, GA. FILED 10-20-2010.

**HUEY LUEY'S FINE MEXICAN  
FOOD**

THE MARK CONSISTS OF STANDARD CHARACTERS WITHOUT CLAIM TO ANY PARTICULAR FONT, STYLE, SIZE, OR COLOR.

NO CLAIM IS MADE TO THE EXCLUSIVE RIGHT TO USE "FINE MEXICAN FOOD", APART FROM THE MARK AS SHOWN.

FOR RESTAURANT AND BAR SERVICES (U.S. CLS. 100 AND 101).

HANNO RITNER, EXAMINING ATTORNEY

SN 85-157,757. BAYSIDE WEDDINGS, LLC, SANTA ROSA BEACH, FL. FILED 10-21-2010.



THE COLOR(S) GREEN, RED AND BLUE IS/ARE CLAIMED AS A FEATURE OF THE MARK.

THE MARK CONSISTS OF A GREEN PALM LEAF APPEARING ABOVE THE STYLIZED, RED WORDING "CABANA" WHICH APPEARS LOCATED ABOVE THE STYLIZED, BLUE WORDING "BLUE".

FOR PROVIDING BANQUET AND SOCIAL FUNCTION FACILITIES FOR SPECIAL OCCASIONS; PROVIDING BANQUET AND SOCIAL FUNCTION FACILITIES FOR SPECIAL OCCASIONS, NAMELY, WEDDINGS (U.S. CLS. 100 AND 101).

MICHAEL TANNER, EXAMINING ATTORNEY

SN 85-158,525. KALMAN FAMILY TRUST, LOS ANGELES, CA. FILED 10-21-2010.

**WILSHIRE MOTEL**

THE MARK CONSISTS OF STANDARD CHARACTERS WITHOUT CLAIM TO ANY PARTICULAR FONT, STYLE, SIZE, OR COLOR.

NO CLAIM IS MADE TO THE EXCLUSIVE RIGHT TO USE "MOTEL", APART FROM THE MARK AS SHOWN.

SEC. 2(F).  
FOR HOTEL AND MOTEL SERVICES (U.S. CLS. 100 AND 101).

FIRST USE 1-1-1948; IN COMMERCE 1-1-1948.

NICHOLAS ALTREE, EXAMINING ATTORNEY

**CLASS 43—(Continued).**

SN 85-158,726. BETTY'S PIES HOLDINGS, LLC, TWO HARBORS, MN. FILED 10-22-2010.

**BETTY'S PIES**

THE MARK CONSISTS OF STANDARD CHARACTERS WITHOUT CLAIM TO ANY PARTICULAR FONT, STYLE, SIZE, OR COLOR.

NO CLAIM IS MADE TO THE EXCLUSIVE RIGHT TO USE "PIES", APART FROM THE MARK AS SHOWN.

THE NAME(S), PORTRAIT(S), AND/OR SIGNATURE(S) SHOWN IN THE MARK IDENTIFIES BETTY LESSARD, WHOSE CONSENT(S) TO REGISTER IS MADE OF RECORD.

FOR RESTAURANT SERVICES (U.S. CLS. 100 AND 101).

FIRST USE 0-0-1984; IN COMMERCE 0-0-1984.

ALICE BENMAMAN, EXAMINING ATTORNEY

SN 85-158,727. BETTY'S PIES HOLDINGS, LLC, TWO HARBORS, MN. FILED 10-22-2010.

**BETTY'S PIES AND EATERY**

THE MARK CONSISTS OF STANDARD CHARACTERS WITHOUT CLAIM TO ANY PARTICULAR FONT, STYLE, SIZE, OR COLOR.

NO CLAIM IS MADE TO THE EXCLUSIVE RIGHT TO USE "PIES AND EATERY", APART FROM THE MARK AS SHOWN.

THE NAME(S), PORTRAIT(S), AND/OR SIGNATURE(S) SHOWN IN THE MARK IDENTIFIES BETTY LESSARD, WHOSE CONSENT(S) TO REGISTER IS MADE OF RECORD.

FOR RESTAURANT AND BAR SERVICES (U.S. CLS. 100 AND 101).

FIRST USE 6-19-2008; IN COMMERCE 6-19-2008.

ALICE BENMAMAN, EXAMINING ATTORNEY

SN 85-169,776. CALCUTTA WRAP & ROLL, ARDSLEY, NY. FILED 11-4-2010.



NO CLAIM IS MADE TO THE EXCLUSIVE RIGHT TO USE "CALCUTTA WRAP & ROLL DELICIOUS INDIAN FOOD TO GO", APART FROM THE MARK AS SHOWN.

THE MARK CONSISTS OF A WOMAN WEARING A SARI WITH A BORDER, WITH ONE FOOT ON A ROLLER SKATE BOARD AND ONE FOOT UP AND HOLDING A WRAP IN HER RIGHT HAND WHILE BRINGING HER LEFT THUMB AND INDEX FINGER TOGETHER TO MAKE THE SIGN OF PERFECT. HER HAIR WHICH IS ADORNED WITH WHITE

**CLASS 43—(Continued).**

FLOWERS CASCADES DOWN TO HER HIPS AND HER BIG EYES ARE WIDE OPEN AND HER SMILE IS SUGGESTING SHE IS DELIGHTED WITH HER DELICIOUS WRAP! THE EDGE OF HER SARI IS WRAPPED OVER HER RIGHT ARM AND THERE IS A BUNCH OF KEYS TIED TO IT. SHE IS WEARING A BINDI ON HER FOREHEAD, BANGLES ON HER WRISTS AND FLIP-FLOP SANDALS ON HER FEET. THE WORDING "CALCUTTA WRAP & ROLL DELICIOUS INDIAN FOOD TO GO" APPEARS TO THE RIGHT OF THE WOMAN.

FOR RESTAURANT SERVICES FEATURING VEGETARIAN AND NON-VEGETARIAN INDIAN FOOD (U.S. CLS. 100 AND 101).

FIRST USE 6-15-2010; IN COMMERCE 9-24-2010.  
TEJBIR SINGH, EXAMINING ATTORNEY

---

SN 85-171,608. SMACKERS FROZEN YOGURT, LLC, COLUMBUS, MS. FILED 11-8-2010.



NO CLAIM IS MADE TO THE EXCLUSIVE RIGHT TO USE "FROZEN YOGURT", APART FROM THE MARK AS SHOWN.

THE COLOR(S) ORANGE, TURQUOISE, BROWN, LIGHT GREEN, WHITE IS/ARE CLAIMED AS A FEATURE OF THE MARK.

THE MARK CONSISTS OF AN ORANGE OVAL WITH AN THIN INSIDE LINE OF TURQUOISE AGAINST THE ORANGE. INSIDE THE OVAL ARE LARGE BROWN LETTERS OF "SMACKERS" TRIMMED IN TURQUOISE. UNDER THAT ARE THE WORDS "FROZEN YOGURT" IN LIGHT GREEN, WITH A STYLIZED CUP OF YOGURT IN ORANGE BETWEEN THE GREEN WORDS.

FOR FROZEN YOGURT SHOP SERVICES IN THE NATURE OF A RESTAURANT (U.S. CLS. 100 AND 101).  
JOHN HWANG, EXAMINING ATTORNEY

---

SN 85-172,334. FRANK JONES CORNER, JACKSON, MS. FILED 11-9-2010.

**F. Jones Corner**

THE MARK CONSISTS OF STANDARD CHARACTERS WITHOUT CLAIM TO ANY PARTICULAR FONT, STYLE, SIZE, OR COLOR.

FOR BAR AND RESTAURANT SERVICES (U.S. CLS. 100 AND 101).

FIRST USE 6-16-2009; IN COMMERCE 6-16-2009.  
CAROLINE WOOD, EXAMINING ATTORNEY

**CLASS 43—(Continued).**

SN 85-174,340. RUTHI B SOLARI, CARDIFF-BY-THE-SEA, CA. FILED 11-11-2010.

**Giving the Gift of Health**

THE MARK CONSISTS OF STANDARD CHARACTERS WITHOUT CLAIM TO ANY PARTICULAR FONT, STYLE, SIZE, OR COLOR.

FOR CHARITABLE SERVICES, NAMELY, PROVIDING FOOD TO NEEDY PERSONS (U.S. CLS. 100 AND 101).

FIRST USE 3-1-2009; IN COMMERCE 6-1-2009.  
GRETCHEN ULRICH, EXAMINING ATTORNEY

---

SN 85-175,551. SEA BREEZE CORPORATION, ALHAMBRA, CA. FILED 11-12-2010.

**Boathouse**

THE MARK CONSISTS OF STANDARD CHARACTERS WITHOUT CLAIM TO ANY PARTICULAR FONT, STYLE, SIZE, OR COLOR.

FOR BAR AND RESTAURANT SERVICES; CARRY-OUT RESTAURANTS; DELICATESSENS; RESTAURANT; RESTAURANT AND BAR SERVICES; RESTAURANT AND BAR SERVICES, INCLUDING RESTAURANT CARRYOUT SERVICES; RESTAURANT SERVICES; RESTAURANT SERVICES FEATURING SANDWICHES; RESTAURANT SERVICES, INCLUDING SIT-DOWN SERVICE OF FOOD AND TAKE-OUT RESTAURANT SERVICES; RESTAURANT SERVICES, NAMELY, PROVIDING OF FOOD AND BEVERAGES FOR CONSUMPTION ON AND OFF THE PREMISES; RESTAURANT, BAR AND CATERING SERVICES; RESTAURANTS; TAKE-OUT RESTAURANT SERVICES (U.S. CLS. 100 AND 101).

FIRST USE 5-23-2008; IN COMMERCE 5-23-2008.  
SOPHIA S. KIM, EXAMINING ATTORNEY

---

SN 85-175,753. SALT LIFE RESTAURANT GROUP LLC, JACKSONVILLE BEACH, FL. FILED 11-12-2010.

**EAT. DRINK. AND BE SALTY.**

THE MARK CONSISTS OF STANDARD CHARACTERS WITHOUT CLAIM TO ANY PARTICULAR FONT, STYLE, SIZE, OR COLOR.

FOR RESTAURANT SERVICES (U.S. CLS. 100 AND 101).

FIRST USE 1-4-2010; IN COMMERCE 1-4-2010.  
JOHN WILKE, EXAMINING ATTORNEY

**CLASS 43—(Continued).**

SN 85-176,434. SENIOR SOLUTIONS, ANDERSON, SC. FILED 11-15-2010.

**DINE IN**

THE MARK CONSISTS OF STANDARD CHARACTERS WITHOUT CLAIM TO ANY PARTICULAR FONT, STYLE, SIZE, OR COLOR.

FOR CHARITABLE SERVICES, NAMELY, PROVIDING FOOD TO THE ELDERLY AND PERSONS OF NEED (U.S. CLS. 100 AND 101).

FIRST USE 11-1-2010; IN COMMERCE 11-1-2010.  
CARYN GLASSER, EXAMINING ATTORNEY

SN 85-176,521. WILL CALL MUSIC AND SPORT, LLC, MIAMI BEACH, FL. FILED 11-15-2010.

**WILL CALL MUSIC AND SPORT**

THE MARK CONSISTS OF STANDARD CHARACTERS WITHOUT CLAIM TO ANY PARTICULAR FONT, STYLE, SIZE, OR COLOR.

NO CLAIM IS MADE TO THE EXCLUSIVE RIGHT TO USE "MUSIC AND SPORT", APART FROM THE MARK AS SHOWN.

FOR BAR AND RESTAURANT SERVICES (U.S. CLS. 100 AND 101).  
JOHN WILKE, EXAMINING ATTORNEY

SN 85-176,781. ZAZA DEVELOPMENT, LLC, CORAL SPRINGS, FL. FILED 11-15-2010.

**tre'za**

THE MARK CONSISTS OF STANDARD CHARACTERS WITHOUT CLAIM TO ANY PARTICULAR FONT, STYLE, SIZE, OR COLOR.

FOR RESTAURANT AND BAR SERVICES (U.S. CLS. 100 AND 101).  
SANJEEV VOHRA, EXAMINING ATTORNEY

**CLASS 43—(Continued).**

SN 85-177,024. YAPPLE, INC., PHILADELPHIA, PA. FILED 11-15-2010.

THE COLOR(S) RED AND GREEN IS/ARE CLAIMED AS A FEATURE OF THE MARK.

THE MARK CONSISTS OF YAPPLE IN RED STYLIZED LETTERS WITH THE LETTER A WITH A GREEN LEAF AND STEM EXTENDING FROM THE TOP OF THE A.

FOR CAFE AND RESTAURANT SERVICES (U.S. CLS. 100 AND 101).

KHANH LE, EXAMINING ATTORNEY

SN 85-177,069. IF YOU KNEW, G.P., DALLAS, TX. FILED 11-15-2010.

**IF YOU KNEW . . . WHAT WOULD YOU DO?**

THE MARK CONSISTS OF STANDARD CHARACTERS WITHOUT CLAIM TO ANY PARTICULAR FONT, STYLE, SIZE, OR COLOR.

FOR CHARITABLE SERVICES, NAMELY, PROVIDING SAFE DRINKING WATER TO THOSE IN DEVELOPING COUNTRIES (U.S. CLS. 100 AND 101).

FIRST USE 9-30-2010; IN COMMERCE 9-30-2010.  
IRA J. GOODSAD, EXAMINING ATTORNEY

SN 85-177,412. MAMMA MIA PIZZERIA, LLC, HAZLET, NJ. FILED 11-16-2010.



THE COLOR(S) RED, GREEN, BLACK AND WHITE IS/ARE CLAIMED AS A FEATURE OF THE MARK.

THE MARK CONSISTS OF A WHITE COLOR FACE WITH BLACK EYES AND MOUTH, HAVING TWO RED COLORED CIRCLES ON THE CHEEKS, WEARING A GREEN CHEF'S CAP AND RED SHOES AS SHOWN IN THE MARK.

FOR PIZZA PARLORS (U.S. CLS. 100 AND 101).  
FIRST USE 9-1-2009; IN COMMERCE 9-1-2009.  
SEAN CROWLEY, EXAMINING ATTORNEY

**CLASS 43—(Continued).**

SN 85-177,611. GB ACQUISITION, INC., CHATTANOOGA, TN. FILED 11-16-2010.

**GB TAVERN**

THE MARK CONSISTS OF STANDARD CHARACTERS WITHOUT CLAIM TO ANY PARTICULAR FONT, STYLE, SIZE, OR COLOR.

OWNER OF U.S. REG. NO. 2,220,305.

NO CLAIM IS MADE TO THE EXCLUSIVE RIGHT TO USE "TAVERN", APART FROM THE MARK AS SHOWN.

FOR RESTAURANT AND CATERING SERVICES, EXCLUDING CONCESSION SERVICES PROVIDED IN STANDS, BOOTHS, BARS AND KIOSKS IN SPORTS ARENAS, STADIUMS, COLISEUMS, SKI RESORTS, UNIVERSITIES, AIRPORTS, PUBLIC PARKS AND ZOOS; CARRY-OUT RESTAURANTS (U.S. CLS. 100 AND 101).

FIRST USE 10-28-2010; IN COMMERCE 10-28-2010.  
ELISSA GARBER KON, EXAMINING ATTORNEY

---

SN 85-177,921. ISLAND FOOD & FUN, INC., LAKE DELTON, WI. FILED 11-16-2010.

**THE REEF AT MARLEY'S**

THE MARK CONSISTS OF STANDARD CHARACTERS WITHOUT CLAIM TO ANY PARTICULAR FONT, STYLE, SIZE, OR COLOR.

OWNER OF U.S. REG. NO. 3,225,517.

FOR BAR AND RESTAURANT SERVICES (U.S. CLS. 100 AND 101).

CHRISIE B. KING, EXAMINING ATTORNEY

---

SN 85-177,985. RAG & BONE HOLDINGS, LLC, NEW YORK, NY. FILED 11-16-2010.

**RAG & BONE**

THE MARK CONSISTS OF STANDARD CHARACTERS WITHOUT CLAIM TO ANY PARTICULAR FONT, STYLE, SIZE, OR COLOR.

OWNER OF U.S. REG. NOS. 2,906,967 AND 3,755,755.

FOR RESTAURANT AND BAR SERVICES (U.S. CLS. 100 AND 101).

GEORGE LORENZO, EXAMINING ATTORNEY

**CLASS 43—(Continued).**

SN 85-178,167. NEW ORLEANS HAMBURGER & SEAFOOD COMPANY, METAIRIE, LA. FILED 11-16-2010.



OWNER OF U.S. REG. NOS. 3,017,598, 3,017,599 AND OTHERS.

NO CLAIM IS MADE TO THE EXCLUSIVE RIGHT TO USE "HAMBURGER & SEAFOOD CO." AND "SINCE 1984", APART FROM THE MARK AS SHOWN.

THE MARK CONSISTS OF THE WORDS "NEW ORLEANS" IN A STYLIZED FONT AT AN ANGLE AGAINST THE BACKGROUND OF A RECTANGLE WITH BEVELED EDGES. UNDERNEATH "NEW ORLEANS" IS A TRIANGLE WITH THE WORDS "SINCE 1984" BELOW WHICH ARE THE WORDS "HAMBURGER & SEAFOOD CO.".

SEC. 2(F) AS TO "NEW ORLEANS".  
FOR RESTAURANT SERVICES (U.S. CLS. 100 AND 101).

FIRST USE 11-15-2008; IN COMMERCE 11-15-2008.  
DORITT L. CARROLL, EXAMINING ATTORNEY

---

SN 85-178,437. GREAT NH RESTAURANTS, INC., BEDFORD, NH. FILED 11-16-2010.

**IN THE PINK**

THE MARK CONSISTS OF STANDARD CHARACTERS WITHOUT CLAIM TO ANY PARTICULAR FONT, STYLE, SIZE, OR COLOR.

FOR RESTAURANT AND BAR SERVICES (U.S. CLS. 100 AND 101).

FIRST USE 10-15-2010; IN COMMERCE 10-15-2010.  
CAROLYN CATALDO, EXAMINING ATTORNEY

**CLASS 43—(Continued).**

SN 85-178,444. LRT FOODS, LLC, DBA ANGRY HAMS GARAGE, FRAMINGHAM, MA. FILED 11-16-2010.



THE MARK CONSISTS OF THE WORDS "ANGRY HAMS GARAGE" IN STYLIZED LETTERING ABOVE AND BELOW CENTRALLY LOCATED IMAGE OF BOAR'S HEAD FIGURE WITH HUMAN BODY SEATED IN HOT ROD AUTOMOBILE AS IF DRIVING.

FOR RESTAURANT AND BAR SERVICES, INCLUDING RESTAURANT CARRYOUT SERVICES (U.S. CLS. 100 AND 101).

FIRST USE 10-24-2010; IN COMMERCE 10-24-2010.  
BRIAN NEVILLE, EXAMINING ATTORNEY

SN 85-179,256. BOBBY GOLDSTEIN, DALLAS, TX. FILED 11-17-2010.

## 3rd Pig's House

THE MARK CONSISTS OF STANDARD CHARACTERS WITHOUT CLAIM TO ANY PARTICULAR FONT, STYLE, SIZE, OR COLOR.

FOR RESTAURANT AND BAR SERVICES, INCLUDING RESTAURANT CARRYOUT SERVICES (U.S. CLS. 100 AND 101).

BRENDAN REGAN, EXAMINING ATTORNEY

SN 85-179,409. BROKEN FLUTE INSTITUTE, INC., DENVER, CO. FILED 11-17-2010.

## CITY O' CITY

THE MARK CONSISTS OF STANDARD CHARACTERS WITHOUT CLAIM TO ANY PARTICULAR FONT, STYLE, SIZE, OR COLOR.

FOR COFFEE SHOP, RESTAURANT AND BAR SERVICES (U.S. CLS. 100 AND 101).

FIRST USE 2-1-2008; IN COMMERCE 3-1-2008.  
BERYL GARDNER, EXAMINING ATTORNEY

**CLASS 43—(Continued).**

SN 85-179,600. RESTAURANT DEVELOPMENT GROUP, LLC, NORTH PALM BEACH, FL. FILED 11-18-2010.

## BURGERFI

THE MARK CONSISTS OF STANDARD CHARACTERS WITHOUT CLAIM TO ANY PARTICULAR FONT, STYLE, SIZE, OR COLOR.

FOR FAST-FOOD RESTAURANTS AND SNACKBARS; RESTAURANTS (U.S. CLS. 100 AND 101).

AISHA SALEM, EXAMINING ATTORNEY

SN 85-179,605. RESTAURANT DEVELOPMENT GROUP, LLC, NORTH PALM BEACH, FL. FILED 11-18-2010.



THE MARK CONSISTS OF THE STYLIZED WORD "BURGERFI" TO THE RIGHT OF A STYLIZED IMAGE OF A HAMBURGER ON A BUN WITH A STAR IN A CIRCLE IN THE MIDDLE OF THE HAMBURGER.

FOR FAST-FOOD RESTAURANTS AND SNACKBARS; RESTAURANTS (U.S. CLS. 100 AND 101).

AISHA SALEM, EXAMINING ATTORNEY

SN 85-179,617. RESTAURANT DEVELOPMENT GROUP, LLC, NORTH PALM BEACH, FL. FILED 11-18-2010.

## THE BURGERFICATION OF THE WORLD

THE MARK CONSISTS OF STANDARD CHARACTERS WITHOUT CLAIM TO ANY PARTICULAR FONT, STYLE, SIZE, OR COLOR.

FOR FAST-FOOD RESTAURANTS AND SNACKBARS; RESTAURANTS (U.S. CLS. 100 AND 101).

AISHA SALEM, EXAMINING ATTORNEY



**CLASS 43—(Continued).**

SN 85-179,622. ARORA, ASHOK K, DBA ASHOK ARORA, NORFOLK, VA. FILED 11-18-2010.

# NAWAB

THE MARK CONSISTS OF STANDARD CHARACTERS WITHOUT CLAIM TO ANY PARTICULAR FONT, STYLE, SIZE, OR COLOR.

FOR RESTAURANT SERVICES (U.S. CLS. 100 AND 101).

FIRST USE 5-1-1992; IN COMMERCE 5-1-1992.  
DAVID TOOLEY, EXAMINING ATTORNEY

---

SN 85-179,633. RESTAURANT DEVELOPMENT GROUP, LLC, NORTH PALM BEACH, FL. FILED 11-18-2010.

# THE BEERIFICATION OF THE WORLD

THE MARK CONSISTS OF STANDARD CHARACTERS WITHOUT CLAIM TO ANY PARTICULAR FONT, STYLE, SIZE, OR COLOR.

FOR FAST-FOOD RESTAURANTS AND SNACKBARS; RESTAURANTS (U.S. CLS. 100 AND 101).

AISHA SALEM, EXAMINING ATTORNEY

---

SN 85-179,711. BULL, JEFFREY, FLOWER MOUND, TX. FILED 11-18-2010.

# SOCIAL BURGER

THE MARK CONSISTS OF STANDARD CHARACTERS WITHOUT CLAIM TO ANY PARTICULAR FONT, STYLE, SIZE, OR COLOR.

NO CLAIM IS MADE TO THE EXCLUSIVE RIGHT TO USE "BURGER", APART FROM THE MARK AS SHOWN.

FOR FAST-FOOD RESTAURANT SERVICES (U.S. CLS. 100 AND 101).

SEAN CROWLEY, EXAMINING ATTORNEY

**CLASS 43—(Continued).**

SN 85-179,862. CELTIC DEVELOPERS GROUP LLC, NEW YORK, NY. FILED 11-18-2010.



THE NAME(S), PORTRAIT(S), AND/OR SIGNATURE(S) SHOWN IN THE MARK DOES NOT IDENTIFY A PARTICULAR LIVING INDIVIDUAL.

FOR BAR AND RESTAURANT SERVICES (U.S. CLS. 100 AND 101).

FIRST USE 10-1-2010; IN COMMERCE 10-1-2010.  
CHRISTINE MARTIN, EXAMINING ATTORNEY

---

SN 85-180,497. TBM HOLDINGS, LLC, MOKENA, IL. FILED 11-18-2010.

# truorleans

THE MARK CONSISTS OF STANDARD CHARACTERS WITHOUT CLAIM TO ANY PARTICULAR FONT, STYLE, SIZE, OR COLOR.

FOR BAR AND RESTAURANT SERVICES (U.S. CLS. 100 AND 101).

KAREN K. BUSH, EXAMINING ATTORNEY

---

SN 85-180,570. PUBTOPIA, LLC, SAN MARCOS, CA. FILED 11-18-2010.

# CRAFT WITHOUT COMPROMISE

THE MARK CONSISTS OF STANDARD CHARACTERS WITHOUT CLAIM TO ANY PARTICULAR FONT, STYLE, SIZE, OR COLOR.

FOR RESTAURANT AND BAR SERVICES (U.S. CLS. 100 AND 101).

FIRST USE 8-1-2010; IN COMMERCE 8-1-2010.

KATHLEEN M. VANSTON, EXAMINING ATTORNEY

**CLASS 43—(Continued).**

SN 85-180,684. LRT FOODS, LLC, DBA ANGRY HAM'S GARAGE, FRAMINGHAM, MA. FILED 11-19-2010.

**Angry Ham's Garage**

THE MARK CONSISTS OF STANDARD CHARACTERS WITHOUT CLAIM TO ANY PARTICULAR FONT, STYLE, SIZE, OR COLOR.

FOR RESTAURANT AND BAR SERVICES, INCLUDING RESTAURANT CARRYOUT SERVICES (U.S. CLS. 100 AND 101).

FIRST USE 10-24-2010; THE MARK WAS FIRST USED ANYWHERE IN A DIFFERENT FORM OTHER THAN THAT SOUGHT TO BE REGISTERED AT LEAST AS EARLY AS 10/24/2010; IN COMMERCE 10-24-2010. THE MARK WAS FIRST USED IN COMMERCE IN A DIFFERENT FORM OTHER THAN THAT SOUGHT TO BE REGISTERED AT LEAST AS EARLY AS 10/24/2010.

BRIAN NEVILLE, EXAMINING ATTORNEY

SN 85-183,784. BEST WESTERN INTERNATIONAL, INC., PHOENIX, AZ. FILED 11-23-2010.

**LOYALTY IS LUCRATIVE**

THE MARK CONSISTS OF STANDARD CHARACTERS WITHOUT CLAIM TO ANY PARTICULAR FONT, STYLE, SIZE, OR COLOR.

FOR HOTEL SERVICES FOR PREFERRED CUSTOMERS (U.S. CLS. 100 AND 101).

REBECCA POVARCHUK, EXAMINING ATTORNEY

SN 85-195,613. BEST WESTERN INTERNATIONAL, INC., PHOENIX, AZ. FILED 12-10-2010.

**WINDSHIELD WARRIOR**

THE MARK CONSISTS OF STANDARD CHARACTERS WITHOUT CLAIM TO ANY PARTICULAR FONT, STYLE, SIZE, OR COLOR.

FOR HOTEL SERVICES (U.S. CLS. 100 AND 101).

REBECCA POVARCHUK, EXAMINING ATTORNEY

**CLASS 43—(Continued).**

SN 85-203,729. THE KESSLER ENTERPRISE, INC., ORLANDO, FL. FILED 12-22-2010.

**ROCKS ON THE RIVER**

THE MARK CONSISTS OF STANDARD CHARACTERS WITHOUT CLAIM TO ANY PARTICULAR FONT, STYLE, SIZE, OR COLOR.

FOR BAR AND RESTAURANT SERVICES (U.S. CLS. 100 AND 101).

FIRST USE 7-25-2009; IN COMMERCE 7-25-2009.

LESLEY LAMOTHE, EXAMINING ATTORNEY

SN 85-203,741. THE KESSLER ENTERPRISE, INC., ORLANDO, FL. FILED 12-22-2010.

**ROCKS ON THE ROOF**

THE MARK CONSISTS OF STANDARD CHARACTERS WITHOUT CLAIM TO ANY PARTICULAR FONT, STYLE, SIZE, OR COLOR.

FOR BAR AND RESTAURANT SERVICES (U.S. CLS. 100 AND 101).

FIRST USE 7-25-2009; IN COMMERCE 7-25-2009.

LESLEY LAMOTHE, EXAMINING ATTORNEY

SN 85-216,323. RESTAURANT DEVELOPMENT GROUP, LLC, NORTH PALM BEACH, FL. FILED 1-12-2011.

**THE BURGERFICATION OF THE NATION**

THE MARK CONSISTS OF STANDARD CHARACTERS WITHOUT CLAIM TO ANY PARTICULAR FONT, STYLE, SIZE, OR COLOR.

FOR FAST-FOOD RESTAURANTS AND SNACKBARS; RESTAURANTS (U.S. CLS. 100 AND 101).

AISHA SALEM, EXAMINING ATTORNEY

**CLASS 43—(Continued).**

SN 85-216,327. RESTAURANT DEVELOPMENT GROUP, LLC, NORTH PALM BEACH, FL. FILED 1-12-2011.

**THE BEERIFICATION OF THE  
NATION**

THE MARK CONSISTS OF STANDARD CHARACTERS WITHOUT CLAIM TO ANY PARTICULAR FONT, STYLE, SIZE, OR COLOR.

FOR FAST-FOOD RESTAURANTS AND SNACKBARS; RESTAURANTS (U.S. CLS. 100 AND 101).  
AISHA SALEM, EXAMINING ATTORNEY

**CLASS 44—(Continued).**

SN 76-705,276. GREEN TEE LAWN CARE, INC., BATAVIA, IL. FILED 11-9-2010.



THE STIPPLING IS FOR SHADING PURPOSES.  
THE MARK CONSISTS OF THE STYLIZED WORDING "GREEN TEE" WITH THE TOP OF THE LETTER "T" EXTENDED ACROSS THE ENTIRE WORDING. ABOVE THE WORDING IS A SILHOUETTE OF A MAN SWINGING A GOLF CLUB, SUPERIMPOSED UPON A SUNBURST DESIGN. THE WORDING SITS ON A DEPICTION OF GRASS.

FOR LAWN CARE SERVICES (U.S. CLS. 100 AND 101).  
FIRST USE 1-1-2007; IN COMMERCE 10-15-2010.  
ANDREA K. NADELMAN, EXAMINING ATTORNEY

SN 85-223,111. HUNEEUS VINTNERS, LLC, RUTHERFORD, CA. FILED 1-21-2011.

**FAUST**

THE MARK CONSISTS OF STANDARD CHARACTERS WITHOUT CLAIM TO ANY PARTICULAR FONT, STYLE, SIZE, OR COLOR.

OWNER OF U.S. REG. NOS. 3,801,172 AND 3,808,542.  
FOR HOTEL, BAR, AND RESTAURANT SERVICES; CATERING; WINE BARS; PROVIDING INFORMATION ABOUT WINE CHARACTERISTICS; SOMMELIER SERVICES, NAMELY, PROVIDING ADVICE ON WINE AND WINE AND FOOD PAIRING (U.S. CLS. 100 AND 101).  
REBECCA POVARCHUK, EXAMINING ATTORNEY

SN 77-109,168. DAVID B SCOTT, JACKSON, TN. FILED 2-16-2007.

**CLASS 44—MEDICAL, BEAUTY AND AGRICULTURAL SERVICES**

SN 76-701,783. E. B. DOES IT, LLC, HAYFORK, CA. FILED 2-24-2010.

**COUNTY GREEN GROWN**

THE MARK CONSISTS OF STANDARD CHARACTERS WITHOUT CLAIM TO ANY PARTICULAR FONT, STYLE, SIZE, OR COLOR.

NO CLAIM IS MADE TO THE EXCLUSIVE RIGHT TO USE "GREEN", APART FROM THE MARK AS SHOWN.  
FOR AGRICULTURAL CONSULTING SERVICES (U.S. CLS. 100 AND 101).

FIRST USE 6-12-2009; IN COMMERCE 6-12-2009.  
JIM RINGLE, EXAMINING ATTORNEY



NO CLAIM IS MADE TO THE EXCLUSIVE RIGHT TO USE "INC.", APART FROM THE MARK AS SHOWN.

THE COLOR(S) BLUE IS/ARE CLAIMED AS A FEATURE OF THE MARK.

THE MARK CONSISTS OF A STYLIZED LETTER "A" WITH THE STYLIZED WORDING "ALPHAMED INC BEGIN HERE" CENTERED BELOW THE STYLIZED LETTER "A." THE ENTIRE MARK IS BLUE.

FOR RENTAL OF MEDICAL EQUIPMENT (U.S. CLS. 100 AND 101).

FIRST USE 1-29-2007; IN COMMERCE 1-29-2007.  
KIM SAITO, EXAMINING ATTORNEY

**CLASS 44—(Continued).**

SN 77-506,004. BIOSCULPTURE TECHNOLOGY, INC., NEW YORK, NY. FILED 6-23-2008.

# Cinch It

THE MARK CONSISTS OF STANDARD CHARACTERS WITHOUT CLAIM TO ANY PARTICULAR FONT, STYLE, SIZE, OR COLOR.

FOR LIPOSUCTION AND SURGICAL BODY SHAPING SERVICES (U.S. CLS. 100 AND 101).

FIRST USE 6-15-2008; IN COMMERCE 6-22-2008.  
MARCIE MILONE, EXAMINING ATTORNEY

---

SN 77-821,546. ZWANGER & PESIRI RADIOLOGY GROUP, LLP, LINDENHURST, NY. FILED 9-8-2009.

# ALO

THE MARK CONSISTS OF STANDARD CHARACTERS WITHOUT CLAIM TO ANY PARTICULAR FONT, STYLE, SIZE, OR COLOR.

FOR PROVIDING MAGNETIC RESONANCE IMAGING SERVICES (U.S. CLS. 100 AND 101).

FIRST USE 7-20-2009; IN COMMERCE 7-20-2009.  
HENRY S. ZAK, EXAMINING ATTORNEY

---

SN 77-824,800. SADRIEH, ALI R, STUDIO CITY, CA. FILED 9-11-2009.

## The Perfect 10! Aesthetic Toe Shortening

THE MARK CONSISTS OF STANDARD CHARACTERS WITHOUT CLAIM TO ANY PARTICULAR FONT, STYLE, SIZE, OR COLOR.

NO CLAIM IS MADE TO THE EXCLUSIVE RIGHT TO USE "AESTHETIC TOE SHORTENING", APART FROM THE MARK AS SHOWN.

FOR COSMETIC AND PLASTIC SURGERY (U.S. CLS. 100 AND 101).

FIRST USE 3-1-2003; IN COMMERCE 3-1-2003.  
CHRISTINE MARTIN, EXAMINING ATTORNEY

**CLASS 44—(Continued).**

SN 77-851,208. FREESTYLE SALON STUDIOS, INC., FORMERLY FREESTYLE SALON LOFTS & LIFESPA, INC., SARASOTA, FL. FILED 10-18-2009.

## FREESTYLE SALON STUDIOS

THE MARK CONSISTS OF STANDARD CHARACTERS WITHOUT CLAIM TO ANY PARTICULAR FONT, STYLE, SIZE, OR COLOR.

NO CLAIM IS MADE TO THE EXCLUSIVE RIGHT TO USE "SALON STUDIOS", APART FROM THE MARK AS SHOWN.

FOR BEAUTY SALONS; HAIR SALON SERVICES; HAIR SALON SERVICES, NAMELY, HAIR CUTTING, STYLING, COLORING, AND HAIR EXTENSION SERVICES; HAIR SALON SERVICES, NAMELY, TREATMENTS TO PROTECT HAIR FROM EFFECTS OF EXPOSURE TO SUNLIGHT, HEAT, HUMIDITY AND CHLORINATED WATER; HAIRDRESSING SALONS (U.S. CLS. 100 AND 101).

FIRST USE 10-26-2009; IN COMMERCE 10-26-2009.  
MARIA-VICTORIA SUAREZ, EXAMINING ATTORNEY

---

SN 77-857,509. NOTSOLDSEPARATELY.COM LLC, MAPLE SHADE, NJ. FILED 10-26-2009.

# avantera

THE MARK CONSISTS OF STANDARD CHARACTERS WITHOUT CLAIM TO ANY PARTICULAR FONT, STYLE, SIZE, OR COLOR.

THE WORDING "AVANTERA" HAS NO MEANING IN A FOREIGN LANGUAGE.

FOR HEALTHCARE SERVICES, NAMELY, MEDICAL CONSULTATIONS FOR ASSISTING PATIENTS IN EXAMINING THEIR MEDICAL TREATMENT PROCESSES, GOALS AND EXPECTATIONS (U.S. CLS. 100 AND 101).

MYRIAH HABEEB, EXAMINING ATTORNEY

**CLASS 44—(Continued).**

SN 77-857,532. NORTH PENINSULA SURGICAL CENTER, L.P., DBA TORRANCE OUTPATIENT SURGERY CENTER, TOPSC, TORRANCE, CA. FILED 10-26-2009.



NO CLAIM IS MADE TO THE EXCLUSIVE RIGHT TO USE "BAND" AND "WEIGHT LOSS PROGRAM", APART FROM THE MARK AS SHOWN.

THE COLOR(S) BLUE AND LIGHT BLUE IS/ARE CLAIMED AS A FEATURE OF THE MARK.

THE MARK CONSISTS OF AN ABSTRACT SILHOUETTE OF A PERSON IN THE MIDDLE WITH BLUE ON BOTTOM FADING TO LIGHT BLUE ON TOP. THERE IS AN OVAL RING AROUND THE MIDSECTION OF THE PERSON WITH BLUE FADING TO LIGHT BLUE FROM RIGHT TO LEFT. THE WORDING "THE LITE BAND" APPEARS IN BLUE STYLIZED FONT CENTERED BELOW THE PERSON. THE WORDING "WEIGHT LOSS PROGRAM" APPEARS IN LIGHT BLUE STYLIZED FONT CENTERED BELOW THE WORDING "THE LITE BAND".

FOR PROVIDING WEIGHT LOSS PROGRAM SERVICES (U.S. CLS. 100 AND 101).

TINA BROWN, EXAMINING ATTORNEY

SN 77-909,773. 5 PAW PETS, INC., TA 5 PAW PETS, INC., HOLLYWOOD, FL. FILED 1-12-2010.

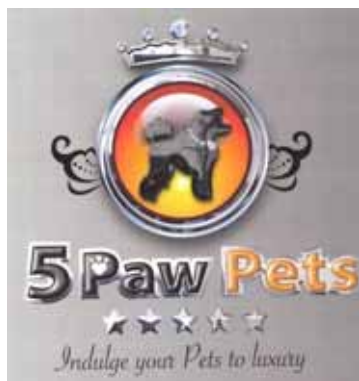

NO CLAIM IS MADE TO THE EXCLUSIVE RIGHT TO USE "PETS", APART FROM THE MARK AS SHOWN.

THE STIPPLING IS A FEATURE OF THE MARK AND DOES NOT INDICATE COLOR.

THE COLOR(S) BLACK, RED, ORANGE, BLUE, PLATINUM, SILVER, YELLOW AND WHITE. IS/ARE CLAIMED AS A FEATURE OF THE MARK.

THE MARK CONSISTS OF THE LITERAL ELEMENT "5 PAW PETS" APPEARING BELOW THE IMAGE OF AN UP FACING PLATINUM RING WITH 5 DIAMONDS ON TOP IN BLUE, 1 LARGE DIAMOND IN THE CENTER AND 4 SMALLER DIAMONDS WITH A CROWN TO HOLD THE DIAMONDS IN PLACE, WITH 2 FANCY WINGS TO THE SIDES IN BLACK AND WHITE WITH DOTS, WITH THE CENTER OF THE RING OF MIXED COLORS OF RED, DARK ORANGE AND SOME YELLOW, WITH A BLACK DOG FACING RIGHT AND STANDING UP, WITH HIS TAIL UP AND WITH A DIAMOND NECKLACE OF 5

**CLASS 44—(Continued).**

DIAMONDS IN BLUE AROUND HIS NECK, 1 BIG DIAMOND TOWARDS THE FRONT OF HIS NECK AND 4 SMALLER DIAMONDS AROUND TOWARDS THE BACK AND BELOW THE DOG IMAGE; THE WORDING "5 PAW" APPEARS IN BLACK IN A THICK FONT WITH A WHITE HEART PAW IN THE CENTER OF "P" OF "PAW", FOLLOWED BY THE WORD "PETS" IN ORANGE, ALL OUTLINED IN WHITE. BELOW THE LITERAL ELEMENT "5 PAW PETS" IS 5 GREY AND SILVER 3 DIMENSIONAL STARS, BELOW WHICH APPEARS THE LITERAL ELEMENT "INDULGE YOUR PETS TO LUXURY" IN BLACK.

FOR (BASED ON USE IN COMMERCE) CONSULTATION SERVICES IN THE FIELD OF PET BEHAVIOR; DOG WALKING SERVICES; PET CARE SERVICES, NAMELY, ADMINISTRATION OF MEDICATION; PET CARE SERVICES, NAMELY, DOG WALKING, DOG BATHING AND NON-MEDICATED PET GROOMING; PET CARE SERVICES, NAMELY, DOG WALKING, DOG BATHING, NON-MEDICATED PET GROOMING AND IN-HOME MEDICAL CARE; PET GROOMING SERVICES; PROVIDING SELF-SERVICE PET WASHING FACILITIES (BASED ON INTENT TO USE) CHARITABLE SERVICES, NAMELY, LENDING TRAINED GUIDE DOGS TO BLIND PEOPLE; CHARITABLE SERVICES, NAMELY, PROVIDING TRAINED SERVICE DOGS TO DISABLED OR CHALLENGED PEOPLE; KENNEL SERVICES, NAMELY, DOG BREEDING SERVICES; PROVIDING ON-LINE INFORMATION VIA THE INTERNET IN THE FIELDS OF ANIMALS AND PETS, RELATING TO BREEDING, SELECTION OF THE ANIMALS AND PETS, GROOMING, FEEDING AND NUTRITION; PROVIDING SELF-SERVICE PET GROOMING FACILITIES (U.S. CLS. 100 AND 101).

FIRST USE 7-21-2008; IN COMMERCE 7-21-2008.

THOMAS MANOR, EXAMINING ATTORNEY

SN 77-920,954. CHILDS HOLDINGS, LLC, SAN ANTONIO, TX. FILED 1-27-2010.

**INDUCTAFIL**

THE MARK CONSISTS OF STANDARD CHARACTERS WITHOUT CLAIM TO ANY PARTICULAR FONT, STYLE, SIZE, OR COLOR.

FOR MEDICAL BIOLOGICS, NAMELY, HUMAN TISSUE ALLOGRAFT USED FOR SURGERY BY COSMETIC SURGEONS, NEURO-SURGEONS, ORTHOPEDIC SURGEONS AND OTHER MEDICAL REPRESENTATIVES (U.S. CLS. 100 AND 101).

MARY CRAWFORD, EXAMINING ATTORNEY

SN 77-937,932. REBOOT COMPANIES, LLC, ST. LOUIS, MO. FILED 2-17-2010.

**REBOOT**

THE MARK CONSISTS OF STANDARD CHARACTERS WITHOUT CLAIM TO ANY PARTICULAR FONT, STYLE, SIZE, OR COLOR.

FOR WEIGHT REDUCTION, DIET PLANNING AND SUPERVISION; NUTRITION COUNSELING (U.S. CLS. 100 AND 101).

LANA PHAM, EXAMINING ATTORNEY

**CLASS 44—(Continued).**

SN 77-961,879. WORLD CONNECT, INC., FORMERLY INFANTE SANO, WALTHAM, MA. FILED 3-18-2010.



World Connect

NO CLAIM IS MADE TO THE EXCLUSIVE RIGHT TO USE "WORLD", APART FROM THE MARK AS SHOWN.

THE MARK CONSISTS OF THE WORDS "WORLD CONNECT" AND A DESIGN OF A RECTANGLE WITH A DECORATIVE BORDER AND CONTAINING A DESIGN OF EIGHT HEARTS WITH A BORDER AND A CENTER FORMING A CIRCLE.

FOR CHARITABLE SERVICES, NAMELY, PROVIDING HEALTH CARE EQUIPMENT (U.S. CLS. 100 AND 101).

SUSAN RICHARDS, EXAMINING ATTORNEY

SN 77-966,502. JOHN HOWARD BROOKS, ABERDEEN, NC. FILED 3-23-2010.



NO CLAIM IS MADE TO THE EXCLUSIVE RIGHT TO USE "CARDIOLOGY", APART FROM THE MARK AS SHOWN.

THE COLOR(S) DARK BROWN, SAGE GREEN, RED, AND LIGHT BLUE IS/ARE CLAIMED AS A FEATURE OF THE MARK.

THE MARK CONSISTS OF THE TREE COMPONENT, MADE OF THE TRUNKS, WHICH ARE DARK BROWN, AND THE LEAVES, WHICH ARE SAGE GREEN. THE HEART COMPONENT IS RED AND IS SET INTO THE NEGATIVE SPACE FORMED BY THE TREE TRUNKS. THE TREE AND HEART COMPONENTS ARE FRONTEED BY A LIGHT BLUE RIBBON-LIKE SHAPE WHICH IS REPRESENTATIVE OF A RIVER. THE "LUMBER RIVER CARDIOLOGY" TEXT IS PLACED TO THE LEFT OF THE 3 COMPONENTS - THE FONT USED FOR THE TEXT IS MYRIAD PRO, DISPLAYED RED IN SMALL CAPS AND RIGHT JUSTIFIED.

FOR MEDICAL SERVICES, NAMELY, CARDIOLOGY (U.S. CLS. 100 AND 101).

FIRST USE 8-1-2008; IN COMMERCE 8-1-2008.  
STEPHANIE ALI, EXAMINING ATTORNEY

**CLASS 44—(Continued).**

SN 77-969,551. FAMILY PRESERVATION SERVICES INCORPORATED, FREDERICKSBURG, VA. FILED 3-26-2010.

## VIRTUAL RESIDENTIAL PROGRAM (VRP)

THE MARK CONSISTS OF STANDARD CHARACTERS WITHOUT CLAIM TO ANY PARTICULAR FONT, STYLE, SIZE, OR COLOR.

NO CLAIM IS MADE TO THE EXCLUSIVE RIGHT TO USE "RESIDENTIAL PROGRAM", APART FROM THE MARK AS SHOWN.

FOR PSYCHOLOGICAL COUNSELING SERVICES IN THE FIELD OF BEHAVIORAL MANAGEMENT, FAMILY COUNSELING, CRISIS INTERVENTION, MEDICATION MONITORING FOR INDIVIDUALS WHO ARE FACING RESIDENTIAL PLACEMENT ISSUES (U.S. CLS. 100 AND 101).

FIRST USE 6-1-1999; IN COMMERCE 6-1-1999.  
ASMAT KHAN, EXAMINING ATTORNEY

SN 85-013,923. FARMER, JOHN, LAKEVILLE, MN. FILED 4-14-2010.

## MESSAGE CHASTITY BELT

THE MARK CONSISTS OF STANDARD CHARACTERS WITHOUT CLAIM TO ANY PARTICULAR FONT, STYLE, SIZE, OR COLOR.

NO CLAIM IS MADE TO THE EXCLUSIVE RIGHT TO USE "MESSAGE", APART FROM THE MARK AS SHOWN.

FOR MESSAGE (U.S. CLS. 100 AND 101).  
GIANCARLO CASTRO, EXAMINING ATTORNEY

SN 85-019,197. MEDAPPS, INC., SCOTTSDALE, AZ. FILED 4-21-2010.

## HEARTPAL

THE MARK CONSISTS OF STANDARD CHARACTERS WITHOUT CLAIM TO ANY PARTICULAR FONT, STYLE, SIZE, OR COLOR.

FOR MEDICAL DIAGNOSTIC TESTING, MONITORING AND REPORTING SERVICES (U.S. CLS. 100 AND 101).

PAUL F. GAST, EXAMINING ATTORNEY

**CLASS 44—(Continued).**

SN 85-023,167. GERMAN AMERICAN CAPITAL CORPORATION, NEW YORK, NY. FILED 4-26-2010.



THE COLOR(S) GREEN AND BLUE IS/ARE CLAIMED AS A FEATURE OF THE MARK.

THE MARK CONSISTS OF THE WORD "THREE" IS IN LOWER CASE LETTERS IN BLUE ABOVE THE LETTER "P" AND "R" OF THE WORD "SPRINGS" WHICH IS IN GREEN. THE "G" IN "SPRINGS" IS IN BLUE AND IS A SQUIGGLY LINE LARGER THAN THE WORD THE REMAINDER OF THE WORD "SPRINGS".

FOR DAY SPA SERVICES, NAMELY, NAIL CARE, MANICURES, PEDICURES AND NAIL ENHANCEMENTS; HEALTH SPA SERVICES FOR HEALTH AND WELLNESS OF THE BODY AND SPIRIT OFFERED AT A HEALTH RESORT; HEALTH SPA SERVICES FOR HEALTH AND WELLNESS OF THE BODY AND SPIRIT, NAMELY, PROVIDING MASSAGE, FACIAL AND BODY TREATMENT SERVICES, COSMETIC BODY CARE SERVICES (U.S. CLS. 100 AND 101).

KELLY BOULTON, EXAMINING ATTORNEY

**CLASS 44—(Continued).**

SN 85-036,637. A.D.A.M., INC., ATLANTA, GA. FILED 5-12-2010.

LIDO.COM

THE MARK CONSISTS OF STANDARD CHARACTERS WITHOUT CLAIM TO ANY PARTICULAR FONT, STYLE, SIZE, OR COLOR.

OWNER OF U.S. REG. NOS. 2,352,070, 2,353,879 AND 2,355,333.

FOR PROVIDING MEDICAL INFORMATION IN THE NATURE OF MEDICAL ILLUSTRATIONS AND IMAGES VIA A GLOBAL COMPUTER NETWORK (U.S. CLS. 100 AND 101).

FIRST USE 6-1-1999; IN COMMERCE 6-1-1999.  
ELI HELLMAN, EXAMINING ATTORNEY

SN 85-025,449. PLAYTEX PRODUCTS, LLC, SHELTON, CT. FILED 4-28-2010.

bottlematch

THE MARK CONSISTS OF STANDARD CHARACTERS WITHOUT CLAIM TO ANY PARTICULAR FONT, STYLE, SIZE, OR COLOR.

FOR PROVIDING AN ON-LINE SEARCHABLE DATABASE FEATURING HEALTH-RELATED INFORMATION ON BABY BOTTLE USE AND SELECTION FOR FEEDING INFANTS (U.S. CLS. 100 AND 101).

RONALD AIKENS, EXAMINING ATTORNEY

SN 85-036,677. A.D.A.M., INC., ATLANTA, GA. FILED 5-12-2010.

LIDO

THE MARK CONSISTS OF STANDARD CHARACTERS WITHOUT CLAIM TO ANY PARTICULAR FONT, STYLE, SIZE, OR COLOR.

OWNER OF U.S. REG. NOS. 2,352,070, 2,353,879 AND 2,355,333.

FOR PROVIDING MEDICAL INFORMATION IN THE NATURE OF MEDICAL ILLUSTRATIONS AND IMAGES VIA A GLOBAL COMPUTER NETWORK (U.S. CLS. 100 AND 101).

FIRST USE 6-1-1999; IN COMMERCE 6-1-1999.  
ELI HELLMAN, EXAMINING ATTORNEY

SN 85-025,929. PLAYTEX PRODUCTS, LLC, SHELTON, CT. FILED 4-29-2010.

CUPMATCH

THE MARK CONSISTS OF STANDARD CHARACTERS WITHOUT CLAIM TO ANY PARTICULAR FONT, STYLE, SIZE, OR COLOR.

FOR PROVIDING AN ON-LINE SEARCHABLE DATABASE FEATURING HEALTH-RELATED INFORMATION ON CHILDREN'S TRAINING CUPS, CUP USE AND CUP SELECTION FOR CHILDREN (U.S. CLS. 100 AND 101).

RONALD AIKENS, EXAMINING ATTORNEY

SN 85-049,075. ROUILLIER, PAUL, BEAUMONT, CANADA, FILED 5-27-2010.

DG29

THE MARK CONSISTS OF STANDARD CHARACTERS WITHOUT CLAIM TO ANY PARTICULAR FONT, STYLE, SIZE, OR COLOR.

FOR PREGNANCY TESTING SERVICES FOR RUMINANT ANIMALS (U.S. CLS. 100 AND 101).

FIRST USE 12-8-2003; IN COMMERCE 5-25-2010.  
JANICE KIM, EXAMINING ATTORNEY

**CLASS 44—(Continued).**

SN 85-057,977. RICE CREEK WATERSHED DISTRICT, BLAINE, MN. FILED 6-9-2010.

BLUE THUMB - PLANTING FOR  
CLEAN WATER

THE MARK CONSISTS OF STANDARD CHARACTERS WITHOUT CLAIM TO ANY PARTICULAR FONT, STYLE, SIZE, OR COLOR.

FOR PROVIDING A WEBSITE FEATURING INFORMATION ABOUT DESIGN, INSTALLATION AND CARE SERVICE FOR NATIVE GARDENS, RAINGARDENS AND SHORELINE STABILIZATION PROJECTS TO LANDOWNERS (U.S. CLS. 100 AND 101).

FLORENTINA BLANDU, EXAMINING ATTORNEY

---

SN 85-088,767. GARDEN STATE SPINE & PAIN INSTITUTE, LLC, OAKHURST, NJ. FILED 7-20-2010.

THE DOCTORS YOU'VE BEEN  
ACHING FOR

THE MARK CONSISTS OF STANDARD CHARACTERS WITHOUT CLAIM TO ANY PARTICULAR FONT, STYLE, SIZE, OR COLOR.

FOR MEDICAL SERVICES, NAMELY, NON-SURGICAL MEDICAL PAIN MANAGEMENT, NAMELY, TRIGGER POINT, EPIDURAL, FACET JOINT AND KNEE INJECTIONS OF ANALGESICS; PHYSICAL THERAPY; SPINAL DECOMPRESSION THERAPY, NAMELY, NON-SURGICAL SPINAL DISC REHABILITATION ACHIEVED THROUGH THE STRETCHING OF THE SPINE AND SEPARATION OF THE VERTEBRAE TO RELIEVE SPINAL DISC IMPINGEMENT ON NERVE ROOTS AND THE THECAL SAC; ACUPUNCTURE; CHIROPRACTIC SERVICES; AND PHYSICIAN-SUPERVISED WEIGHT MANAGEMENT SERVICES, NAMELY, PROVIDING WEIGHT LOSS AND/OR WEIGHT MAINTENANCE PROGRAMS (U.S. CLS. 100 AND 101).

FIRST USE 2-0-2004; IN COMMERCE 2-0-2005.

BILL DAWE, EXAMINING ATTORNEY

**CLASS 44—(Continued).**

SN 85-109,269. U.S. MEDICAL MANAGEMENT, LLC, FARMINGTON HILLS, MI. FILED 8-17-2010.



NO CLAIM IS MADE TO THE EXCLUSIVE RIGHT TO USE "SENIOR" AND "HOME HEALTH", APART FROM THE MARK AS SHOWN.

THE COLOR(S) GRAY, BURGUNDY, AND BLACK IS/ARE CLAIMED AS A FEATURE OF THE MARK.

THE MARK CONSISTS OF THE ROOF AND GABLES OF A HOUSE APPEARING IN GRAY AND BLACK, SITTING ATOP THE WORDS "CHERISH SENIOR" IN BURGUNDY, UNDER WHICH APPEARS THE WORDING "HOME HEALTH" IN BLACK. THE WHITE SHOWN IN THE MARK IS FOR BACKGROUND PURPOSES ONLY AND IS NOT CLAIMED AS A FEATURE OF THE MARK.

FOR CONDUCTING MEDICAL PHYSICAL EVALUATIONS; CONSULTATION SERVICES IN THE FIELD OF PALLIATIVE CARE; CONSULTING IN THE FIELD OF HEALTH AND WELLNESS TO BRING ABOUT PERSONAL HAPPINESS; CONSULTING SERVICES IN THE FIELD OF HEALTH; CONSULTING SERVICES IN THE FIELD OF MEDICAL CARE; GERIATRIC HEALTH CARE MANAGEMENT SERVICES; HEALTH CARE; HEALTH CARE SERVICES, NAMELY, WELLNESS PROGRAMS; HOME HEALTH CARE SERVICES; MAINTAINING FILES AND RECORDS CONCERNING THE MEDICAL CONDITION OF INDIVIDUALS; MEDICAL CONSULTATIONS; MEDICAL COUNSELING; MEDICAL INFORMATION; MEDICAL SCREENING; NURSING CARE; NURSING SERVICES; OCCUPATIONAL THERAPY SERVICES; PHYSICAL REHABILITATION; PHYSICAL THERAPY; PHYSICIAN SERVICES; PROVIDING A WEB SITE FEATURING MEDICAL INFORMATION; PROVIDING IN-PERSON HOLISTIC HEALTH CARE SERVICES; PROVIDING INFORMATION, NEWS AND COMMENTARY IN THE FIELD OF NUTRITION, HEALTH AND WELLNESS; PROVIDING MEDICAL INFORMATION, CONSULTANCY AND ADVISORY SERVICES; WELLNESS AND HEALTH-RELATED CONSULTING SERVICES (U.S. CLS. 100 AND 101).

AMY ALFIERI, EXAMINING ATTORNEY

---

SN 85-124,373. EASTER SEAL SOCIETY OF SUPERIOR CALIFORNIA, SACRAMENTO, CA. FILED 9-7-2010.



THE COLOR(S) BLACK, WHITE, TAN, GREEN, BLUE, YELLOW, RED, PINK BLACK, TAN, GREEN, BLUE, YELLOW, RED AND PINK IS/ARE CLAIMED AS A FEATURE OF THE MARK.

THE MARK CONSISTS OF A STICK FIGURE DEPICTION OF A SMILING FAMILY HOLDING HANDS AND STANDING SIDE BY SIDE IN A LINE. THE FAMILY IS STANDING IN THE FOLLOWING ORDER FROM LEFT TO RIGHT; A



**CLASS 44—(Continued).**

CHILD DRESSED IN GREEN WITH GREEN SHOES SITTING IN A GREEN WHEELCHAIR WITH A BLACK WHEEL WITH WHITE IN THE CENTER, A CHILD DRESSED IN BLUE WITH BLUE SHOES, A FATHER DRESSED IN YELLOW WITH TAN SHOES, A MOTHER DRESSED IN RED WITH RED SHOES AND A YOUNG DAUGHTER DRESSED IN PINK WITH PINK SHOES. ALL OF THE STICK FIGURES ARE OUTLINED IN BLACK AND HAVE TAN FACES AND ARE HOLDING HANDS, WHICH ARE OUTLINED IN BLACK AND FILLED WITH TAN.

FOR OCCUPATIONAL THERAPY SERVICES; PHYSICAL THERAPY; PHYSICAL THERAPY EVALUATION, IDENTIFICATION, AND MANAGEMENT OF MOVEMENT DYSFUNCTION TO RESTORE, MAINTAIN, AND PROMOTE OPTIMAL PHYSICAL FUNCTION PREVENTING THE ONSET, SYMPTOMS AND PROGRESSION OF IMPAIRMENTS, FUNCTIONAL LIMITATIONS, AND DISABILITIES RESULTING FROM DISEASE, DISORDERS, CONDITIONS, OR INJURIES; PROVIDING PHYSICAL REHABILITATION FACILITIES; SPEECH AND HEARING THERAPY; SPEECH THERAPY SERVICES (U.S. CLS. 100 AND 101).

FIRST USE 1-1-2008; IN COMMERCE 1-1-2008.  
MYRIAH HABEEB, EXAMINING ATTORNEY

---

SN 85-129,306. IRONSIDE, JEFFREY, OAK PARK, IL, AND WAKAI, KATHLEEN, OAK PARK, IL. FILED 9-14-2010.

**SKINNY DIPPIN' DOGS**

THE MARK CONSISTS OF STANDARD CHARACTERS WITHOUT CLAIM TO ANY PARTICULAR FONT, STYLE, SIZE, OR COLOR.

NO CLAIM IS MADE TO THE EXCLUSIVE RIGHT TO USE "DOGS", APART FROM THE MARK AS SHOWN.

FOR ANIMAL GROOMING; ANIMAL GROOMING SERVICES; DOG GROOMING SERVICES; DOG WALKING SERVICES; PET CARE SERVICES, NAMELY, DOG WALKING, DOG BATHING AND NON-MEDICATED PET GROOMING; PET GROOMING SERVICES; PROVIDING INFORMATION AND ADVICE IN THE FIELD OF PET HEALTH (U.S. CLS. 100 AND 101).

INGA ERVIN, EXAMINING ATTORNEY

---

SN 85-133,484. THE WDE GROUP LLC, WAYNE, PA. FILED 9-20-2010.

**Psychenquiry**

THE MARK CONSISTS OF STANDARD CHARACTERS WITHOUT CLAIM TO ANY PARTICULAR FONT, STYLE, SIZE, OR COLOR.

FOR PROVIDING A WEBSITE FEATURING INFORMATION IN THE FIELD OF THE DIAGNOSIS AND TREATMENT OF PSYCHIATRIC, PSYCHOLOGICAL, AND DEVELOPMENTAL DISORDERS (U.S. CLS. 100 AND 101).

DAWN HAN, EXAMINING ATTORNEY

**CLASS 44—(Continued).**

SN 85-133,613. FEINGOLD, DR. PINA, SUFFERN, NY. FILED 9-20-2010.

**MOONLIGHT PEDIATRICS**

THE MARK CONSISTS OF STANDARD CHARACTERS WITHOUT CLAIM TO ANY PARTICULAR FONT, STYLE, SIZE, OR COLOR.

NO CLAIM IS MADE TO THE EXCLUSIVE RIGHT TO USE "PEDIATRICS", APART FROM THE MARK AS SHOWN.

FOR PEDIATRIC MEDICAL AND HEALTHCARE SERVICES (U.S. CLS. 100 AND 101).

AISHA CLARKE, EXAMINING ATTORNEY

---

SN 85-143,940. LIE, ROBIN K, DBA FIT FEET PODIATRY, LOMA LINDA, CA. FILED 10-3-2010.

**Fit Feet Podiatry**

THE MARK CONSISTS OF STANDARD CHARACTERS WITHOUT CLAIM TO ANY PARTICULAR FONT, STYLE, SIZE, OR COLOR.

NO CLAIM IS MADE TO THE EXCLUSIVE RIGHT TO USE "PODIATRY", APART FROM THE MARK AS SHOWN.

FOR PODIATRY SERVICES (U.S. CLS. 100 AND 101).

FIRST USE 10-3-2010; IN COMMERCE 10-3-2010.

LAURA KOVALSKY, EXAMINING ATTORNEY

---

SN 85-144,766. SPINE VIEW, INC., FREMONT, CA. FILED 10-4-2010.

**ECIF**

THE MARK CONSISTS OF STANDARD CHARACTERS WITHOUT CLAIM TO ANY PARTICULAR FONT, STYLE, SIZE, OR COLOR.

FOR MEDICAL SERVICES, NAMELY, MINIMALLY INVASIVE SPINAL SURGICAL PROCEDURES, ENDOSCOPIC SPINAL PROCEDURES, AND PERCUTANEOUS SPINAL SURGICAL PROCEDURES (U.S. CLS. 100 AND 101).

DAVID C. REIHNER, EXAMINING ATTORNEY

**CLASS 44—(Continued).**

SN 85-144,768. SPINE VIEW, INC., FREMONT, CA. FILED 10-4-2010.

**ELIF**

THE MARK CONSISTS OF STANDARD CHARACTERS WITHOUT CLAIM TO ANY PARTICULAR FONT, STYLE, SIZE, OR COLOR.

FOR MEDICAL SERVICES, NAMELY, MINIMALLY INVASIVE SPINAL SURGICAL PROCEDURES, ENDOSCOPIC SPINAL PROCEDURES, AND PERCUTANEOUS SPINAL SURGICAL PROCEDURES (U.S. CLS. 100 AND 101).

DAVID C. REIHNER, EXAMINING ATTORNEY

**CLASS 44—(Continued).**

SN 85-146,411. QUESTCARE MEDICAL SERVICES, P.A., DALLAS, TX. FILED 10-6-2010.

**LEVEL 5 HEALTHCARE**

THE MARK CONSISTS OF STANDARD CHARACTERS WITHOUT CLAIM TO ANY PARTICULAR FONT, STYLE, SIZE, OR COLOR.

NO CLAIM IS MADE TO THE EXCLUSIVE RIGHT TO USE "HEALTHCARE", APART FROM THE MARK AS SHOWN.

FOR MEDICAL ASSISTANCE SERVICES; PHYSICIAN SERVICES (U.S. CLS. 100 AND 101).

GINA FINK, EXAMINING ATTORNEY

SN 85-146,065. MEDPSYCH HEALTH SERVICES LLC, N POTOMAC, MD. FILED 10-6-2010.



NO CLAIM IS MADE TO THE EXCLUSIVE RIGHT TO USE "HEALTH SERVICES", APART FROM THE MARK AS SHOWN.

THE COLOR(S) BLUE AND YELLOW IS/ARE CLAIMED AS A FEATURE OF THE MARK.

THE MARK CONSISTS OF AN "M", "H", PSI (GREEK) "MEDPSYCH HEALTH SERVICES", HAPPY PEOPLE ON TOP OF THE "D" AND "P" IN BOOMRANG SHAPE ARMS AND LEGS. THE PSI SHAPED "M" HAS FIRST TWO ARMS IN BLUE AND SHARES ITS THIRD ARM WITH "H" IN YELLOW. THE "H" IS IN YELLOW AND LEFT PART OF THE SYMBOL RESEMBLES INVERTED GREEK PSI SYMBOL. THE "MED" HAPPY BOOMERANG PERSON ON TOP OF "D" AND "HEALTH SERVICES" ARE IN BLUE AND "PSYCH" AND HAPPY BOOMERANG PERSON ON TOP OF "P" IS IN YELLOW.

FOR MENTAL HEALTH SERVICES (U.S. CLS. 100 AND 101).

FIRST USE 7-1-2009; IN COMMERCE 9-24-2009.  
ROBIN CHOSID, EXAMINING ATTORNEY

SN 85-146,840. MORENO, FABIAN, SUNNYVALE, CA. FILED 10-6-2010.



NO CLAIM IS MADE TO THE EXCLUSIVE RIGHT TO USE "SMILES", APART FROM THE MARK AS SHOWN.

THE MARK CONSISTS OF THE WORD "CIRRUS" WRITTEN ABOVE THE WORD "SMILES" IN BETWEEN PROCEEDING WITH A SMALL SMILE BELOW.

FOR DENTAL IMAGING SERVICES; DENTAL LABORATORIES (U.S. CLS. 100 AND 101).

FIRST USE 7-1-2010; IN COMMERCE 7-1-2010.  
DAVID TAYLOR, EXAMINING ATTORNEY

**CLASS 44—(Continued).**

SN 85-149,567. BELL, JULIA, LOS ANGELES, CA. FILED 10-11-2010.



NO CLAIM IS MADE TO THE EXCLUSIVE RIGHT TO USE "DOG" AND "LA", APART FROM THE MARK AS SHOWN.

THE MARK CONSISTS OF THE DESIGN OF A SHIELD WITH THE WORDS "DOG CAMP LA" INSIDE THE SHIELD. THE WORDING "DOG CAMP" IS AT THE TOP OF THE SHIELD AND THE WORDING "LA" IS AT THE BOTTOM OF THE SHIELD. THE "LA" BISECTS THE DESIGN OF A BONE. ABOVE THE "LA" IS A PICTURE OF A DOG'S FACE WITH TWO TREES ON EITHER SIDE.

FOR CONSULTATION SERVICES IN THE FIELD OF PET BEHAVIOR; PET CARE SERVICES, NAMELY, ADMINISTRATION OF MEDICATION; PET CARE SERVICES, NAMELY, DOG WALKING, DOG BATHING AND NON-MEDICATED PET GROOMING; PET DENTIST SERVICES; PROVIDING INFORMATION AND ADVICE IN THE FIELD OF PET HEALTH; PROVIDING ON-LINE INFORMATION VIA THE INTERNET IN THE FIELDS OF ANIMALS AND PETS, RELATING TO BREEDING, SELECTION OF THE ANIMALS AND PETS, GROOMING, FEEDING AND NUTRITION (U.S. CLS. 100 AND 101).

FIRST USE 4-8-2002; IN COMMERCE 4-8-2002.  
DAWN FELDMAN, EXAMINING ATTORNEY

**CLASS 44—(Continued).**

SN 85-150,091. RADAR HAIR &amp; RECORDS LLC., DBA RADAR HAIR &amp; RECORDS, SEATTLE, WA. FILED 10-11-2010.



NO CLAIM IS MADE TO THE EXCLUSIVE RIGHT TO USE "HAIR & RECORDS", APART FROM THE MARK AS SHOWN.

THE MARK CONSISTS OF THE WORDING "RADAR HAIR & RECORDS" WITH A SATELLITE ABOVE THE FIRST "A" IN "RADAR".

FOR BEAUTY SALON SERVICES; BEAUTY SALONS; HAIR COLOR SALON SERVICES; HAIR SALON SERVICES; HAIR SALON SERVICES, NAMELY, HAIR CUTTING, STYLING, COLORING, AND HAIR EXTENSION SERVICES; HAIR SALON SERVICES, NAMELY, TREATMENTS TO PROTECT HAIR FROM EFFECTS OF EXPOSURE TO SUNLIGHT, HEAT, HUMIDITY AND CHLORINATED WATER; HAIRDRESSING SALONS; MAKING RESERVATIONS AND BOOKINGS FOR OTHERS AT BEAUTY SALONS; RENTAL OF MACHINES AND APPARATUS FOR USE IN BEAUTY SALONS OR BARBERS' SHOPS; SALON SERVICES, NAMELY, FACIALS, MANICURES AND MASSAGES THAT ARE PROVIDED IN A TRAILER OUTFITTED WITH CHAIR, TABLE AND SINK ACCESSORIES (U.S. CLS. 100 AND 101).

FIRST USE 7-1-2010; IN COMMERCE 7-1-2010.  
KIMBERLY FRYE, EXAMINING ATTORNEY

SN 85-150,213. MERCURY, LLC, PHOENIX, AZ. FILED 10-12-2010.

**PRIME VITALITY**

THE MARK CONSISTS OF STANDARD CHARACTERS WITHOUT CLAIM TO ANY PARTICULAR FONT, STYLE, SIZE, OR COLOR.

FOR MEDICAL SERVICES, NAMELY, MEN'S CLINIC PROVIDING FOR HORMONE REPLACEMENT THERAPY, TREATING SPORTS RELATED INJURIES, MUSCLE SORENESS, ERECTILE DYSFUNCTION, EVERYDAY ILLNESS, AND PROVIDING NUTRITION COUNSELING AND WEIGHT LOSS SOLUTIONS (U.S. CLS. 100 AND 101).

SANJEEV VOHRA, EXAMINING ATTORNEY

**CLASS 44—(Continued).**

SN 85-151,109. CARING HANDS FOR SENIORS, BRISTOW, VA. FILED 10-12-2010.



NO CLAIM IS MADE TO THE EXCLUSIVE RIGHT TO USE "SENIORS/SPECIAL NEEDS", APART FROM THE MARK AS SHOWN.

THE COLOR(S) RED, BLUE, WHITE AND BLACK IS/ARE CLAIMED AS A FEATURE OF THE MARK.

THE MARK CONSISTS OF THE WORDS "COMPASSIONATE HEARTS FOR SENIORS/SPECIAL NEEDS" AND THE DESIGN OF AN ANGEL HOLDING A HEART. THE LETTER "C" IN "COMPASSIONATE" IS THE COLOR RED, THE REMAINING LETTERS ARE BLACK; THE LETTER "H" IN THE WORD "HEARTS" APPEARS IN THE COLOR RED, THE REMAINING LETTERS ARE BLACK; THE LETTER "F" IN THE WORD "FOR" APPEARS IN THE COLOR RED, THE REMAINING LETTERS ARE BLACK; THE LETTER "S" IN THE WORD "SENIORS" APPEARS IN THE COLOR RED, THE REMAINING LETTERS ARE BLACK; THE WORDS "SPECIAL NEEDS" APPEAR IN THE COLOR BLACK; THERE IS AN ANGEL OUTLINED IN COLOR BLUE; THE BODY OF THE ANGEL IS IN THE COLOR WHITE; THE ANGEL IS HOLDING A HEART; THE HEART IS OUTLINED IN THE COLOR BLUE; THE COLOR RED APPEARS INSIDE THE HEART.

FOR HOME HEALTH CARE SERVICES; HOME HEALTH CARE SERVICES, NAMELY, PHYSICAL THERAPY AND SKILLED NURSING; HOME NURSING AID SERVICES (U.S. CLS. 100 AND 101).

KELLY TRUSILO, EXAMINING ATTORNEY

SN 85-151,623. PEDERSEN, JOHN CARL, AKRON, OH. FILED 10-13-2010.

**BREAST OASIS**

THE MARK CONSISTS OF STANDARD CHARACTERS WITHOUT CLAIM TO ANY PARTICULAR FONT, STYLE, SIZE, OR COLOR.

OWNER OF U.S. REG. NO. 3,834,464.

NO CLAIM IS MADE TO THE EXCLUSIVE RIGHT TO USE "BREAST", APART FROM THE MARK AS SHOWN.

FOR HEALTH INFORMATION PROGRAMS, NAMELY, PROVIDING HEALTH INFORMATION; PROVIDING INFORMATION ON GENERAL HEALTH, WELLNESS AND ILLNESS PREVENTION TOPICS (U.S. CLS. 100 AND 101).

JEFFREY LOOK, EXAMINING ATTORNEY

**CLASS 44—(Continued).**

SN 85-151,708. PEDERSEN, JOHN CARL, AKRON, OH. FILED 10-13-2010.



OWNER OF U.S. REG. NO. 3,900,102.

THE COLOR(S) PINK AND WHITE IS/ARE CLAIMED AS A FEATURE OF THE MARK.

THE MARK CONSISTS OF A WHITE TRIANGLE WITH THE BOTTOM SIDE OF THE TRIANGLE DEPICTING A BRA, AND THE TOP OF THE TRIANGLE FORMED BY DIRECTIONAL ARROWS, ALL ENCLOSED IN A PINK CIRCLE.

FOR HEALTH INFORMATION PROGRAMS, NAMELY, PROVIDING HEALTH INFORMATION; PROVIDING INFORMATION ON GENERAL HEALTH, WELLNESS AND ILLNESS PREVENTION TOPICS (U.S. CLS. 100 AND 101).

JEFFREY LOOK, EXAMINING ATTORNEY

SN 85-151,764. LITTLE STAR CENTER, INC., CARMEL, IN. FILED 10-13-2010.



NO CLAIM IS MADE TO THE EXCLUSIVE RIGHT TO USE "CENTER", APART FROM THE MARK AS SHOWN.

THE COLOR(S) BLUE, GOLD AND WHITE IS/ARE CLAIMED AS A FEATURE OF THE MARK.

THE MARK CONSISTS OF THREE STYLIZED STARS CONNECTED IN LINE AND IN LINE CONNECTED TO A STYLIZED KID, ALL OF WHICH IS IN BLUE WITH A WHITE AND THEN A GOLD BORDER, UNDER WHICH APPEAR THE BLUE STYLIZED LETTERS LITTLE STAR CENTER, AND UNDER WHICH APPEAR THE TAG LINES IN GOLD, WHERE KIDS WITH AUTISM LEARN TO LIVE IN THE WORLD., AND, WHERE PARENTS LEARN THEY ARE NOT ALONE.

FOR PROVIDING BEHAVIORAL THERAPY FOR CHILDREN WITH AUTISM (U.S. CLS. 100 AND 101).

ANNE E. GUSTASON, EXAMINING ATTORNEY

**CLASS 44—(Continued).**

SN 85-152,168. AURA SKIN SPA #1 INC., SAN FRANCISCO, CA. FILED 10-13-2010.



NO CLAIM IS MADE TO THE EXCLUSIVE RIGHT TO USE "SKIN SPA REJUVENATION", APART FROM THE MARK AS SHOWN.

THE COLOR(S) DARK BLUE AND LIGHT BLUE IS/ARE CLAIMED AS A FEATURE OF THE MARK.

THE MARK CONSISTS OF FOUR SMALLER SQUARES IN ALTERNATING DARK BLUE AND LIGHT BLUE COLORS, PUT TOGETHER TO FORM A LARGER SQUARE, AND BENEATH THAT THE WORD "AURA" IN DARK BLUE FOLLOWED BY THE WORDS "SKIN SPA" IN LIGHT BLUE, AND BENEATH THAT THE WORDS "REJUVENATION THROUGH SCIENCE" IN LIGHT BLUE.

FOR BEAUTY SPA SERVICES, NAMELY, COSMETIC BODY CARE; COSMETIC BODY CARE SERVICES; COSMETIC FACE CARE SERVICES; COSMETIC SKIN CARE SERVICES; FACIAL TREATMENT SERVICES, NAMELY, COSMETIC PEELS; HEALTH SPA SERVICES, NAMELY, COSMETIC BODY CARE SERVICES; HEALTH SPA SERVICES, NAMELY, LASER TREATMENTS FOR ACNE, REJUVENATION, SCARS, TATTOO REMOVAL AND FOR FACIALS AND MASSAGE; HYGIENIC AND BEAUTY CARE; LASER AND INTENSE PULSE LIGHT SKIN ENHANCEMENT PROCEDURES; LASER HAIR REMOVAL SERVICES; MEDICAL SKIN CARE SERVICES; MEDICAL SPA SERVICES, NAMELY, MINIMALLY AND NON-INVASIVE COSMETIC AND BODY FITNESS THERAPIES; PERMANENT HAIR REMOVAL AND REDUCTION SERVICES; SKIN TREATMENT, NAMELY, THE INJECTION OF DERMAL FILLERS TO REDUCE THE APPEARANCE OF FACIAL FINE LINES; SKIN TREATMENTS, NAMELY, THE INJECTION OF DERMAL FILLING AGENTS AND NEUROMUSCULAR BLOCKING AGENTS TO REDUCE THE APPEARANCE OF FACIAL LINES AND WRINKLES (U.S. CLS. 100 AND 101).

FIRST USE 9-1-2006; IN COMMERCE 9-1-2006.

LAURIE MAYES, EXAMINING ATTORNEY

SN 85-153,800. STEPPING STONE CENTER FOR RECOVERY, LLC, POMPANO BEACH, FL. FILED 10-15-2010.



NO CLAIM IS MADE TO THE EXCLUSIVE RIGHT TO USE "CENTER FOR RECOVERY", APART FROM THE MARK AS SHOWN.

THE MARK CONSISTS OF A RECTANGULAR FRAME AROUND A DRAWING OF A PATHWAY BORDERED ON THE LEFT AND RIGHT BY PLANTS AND LEADING TO A RISING SUN. UNDERNEATH ARE THE WORDS "STEPPING STONE" IN CAPITAL LETTERS ABOVE THE WORDS "CENTER FOR RECOVERY" IN CAPITAL LETTERS.

FOR RESIDENTIAL TREATMENT FOR ALCOHOL AND DRUG REHABILITATION (U.S. CLS. 100 AND 101).

FIRST USE 12-31-2004; IN COMMERCE 12-31-2004.

THOMAS MANOR, EXAMINING ATTORNEY

**CLASS 44—(Continued).**

SN 85-153,950. LAKEVIEW HEALTH SYSTEMS, L.L.C., POMPANO BEACH, FL. FILED 10-15-2010.



NO CLAIM IS MADE TO THE EXCLUSIVE RIGHT TO USE "HEALTH SYSTEMS", APART FROM THE MARK AS SHOWN.

THE MARK CONSISTS OF THE CAPITAL LETTERS "LVH" WITH A DEPICTION OF A SAILBOAT ON WATER AND THE MOON WITHIN THE LETTERS AND THE WORD "LAKEVIEW" ABOVE THE WORDS "HEALTH SYSTEMS" ALL IN CAPITAL LETTERS AND ALL HORIZONTALLY PARALLEL TO THE RIGHT OF THE LETTERS "LVH".

FOR ALCOHOL AND DRUG REHABILITATION SERVICES PROVIDED IN A RESIDENTIAL TREATMENT FACILITY (U.S. CLS. 100 AND 101).

FIRST USE 12-31-2004; IN COMMERCE 12-31-2004.

AMY ALFIERI, EXAMINING ATTORNEY

SN 85-155,594. MERCURY, LLC, PHOENIX, AZ. FILED 10-19-2010.

## MEN'S VITALITY AND PERFORMANCE

THE MARK CONSISTS OF STANDARD CHARACTERS WITHOUT CLAIM TO ANY PARTICULAR FONT, STYLE, SIZE, OR COLOR.

NO CLAIM IS MADE TO THE EXCLUSIVE RIGHT TO USE "MEN'S", APART FROM THE MARK AS SHOWN.

FOR MEDICAL SERVICES, NAMELY, MEN'S CLINIC FOR PROVIDING HORMONE REPLACEMENT THERAPY, TREATING SPORTS RELATED INJURIES, MUSCLE SORENESS, ERECTILE DYSFUNCTION, EVERYDAY ILLNESS, AND PROVIDING NUTRITION COUNSELING AND WEIGHT LOSS SOLUTIONS (U.S. CLS. 100 AND 101).

SANJEEV VOHRA, EXAMINING ATTORNEY

SN 85-156,300. AMERICAN MANAGEMENT GROUP, LLC, DBA A+ ENDODONTIC SPECIALTY CARE, P.C., FORT WASHINGTON, PA. FILED 10-19-2010.



NO CLAIM IS MADE TO THE EXCLUSIVE RIGHT TO USE "ENDO" AND "ENDODONTIC SPECIALTY CARE, P.C.", APART FROM THE MARK AS SHOWN.

THE COLOR(S) PEACH, GRAY, BLACK AND RED IS/ARE CLAIMED AS A FEATURE OF THE MARK.

THE MARK CONSISTS OF THE TERMS "A+ ENDO" IN GRAY, WITH THE PLUS SIGN SHOWN IN RED IN A PEACH TOOTH ABOVE THE "A", ALL ABOVE THE TERMS "A+ ENDODONTIC SPECIALTY CARE, P.C." IN BLACK.

FOR DENTIST SERVICES (U.S. CLS. 100 AND 101).

FIRST USE 9-1-2010; IN COMMERCE 9-1-2010.

HELENE LIWINSKI, EXAMINING ATTORNEY

**CLASS 44—(Continued).**

SN 85-156,322. AMERICAN MANAGEMENT GROUP, LLC, DBA A+ ORAL SURGERY SPECIALTY CARE, P.C., FORT WASHINGTON, PA. FILED 10-19-2010.



NO CLAIM IS MADE TO THE EXCLUSIVE RIGHT TO USE "ORAL SURGERY SPECIALTY CARE, P.C." AND THE CADUCEUS SYMBOL, APART FROM THE MARK AS SHOWN.

THE COLOR(S) GRAY, WHITE, LIGHT BLUE, BLUE, AND BLACK IS/ARE CLAIMED AS A FEATURE OF THE MARK.

THE MARK CONSISTS OF THE TERMS "A+OS" WITH THE LETTERS IN GRAY AND THE "+" IN BLUE, A LIGHT BLUE TOOTH ABOVE THE "A", AND A LIGHT BLUE CADUCEUS SYMBOL IN THE "O", THE INSIDE OF THE "O" BEING HALF GRAY, HALF WHITE, ALL ABOVE THE TERMS "A+ ORAL SURGERY SPECIALTY CARE, P.C." IN BLACK.

FOR DENTIST SERVICES (U.S. CLS. 100 AND 101).  
FIRST USE 9-1-2010; IN COMMERCE 9-1-2010.  
HELENE LIWINSKI, EXAMINING ATTORNEY

**CLASS 44—(Continued).**

SN 85-156,402. AMERICAN MANAGEMENT GROUP, LLC, DBA A+ PEDIATRIC DENTAL SPECIALTY CARE, P.C., FORT WASHINGTON, PA. FILED 10-19-2010.



NO CLAIM IS MADE TO THE EXCLUSIVE RIGHT TO USE "PEDIATRIC DENTAL" AND "PEDIATRIC DENTAL SPECIALTY CARE, P.C.", APART FROM THE MARK AS SHOWN.

THE COLOR(S) GRAY, BLACK, LIGHT SKY BLUE, BLUE, YELLOW, GREEN, RED, AND PINK IS/ARE CLAIMED AS A FEATURE OF THE MARK.

THE MARK CONSISTS OF THE STYLIZED TERMS "A+PEDIATRIC DENTAL" IN GRAY AND, A LIGHT SKY BLUE TOOTH ABOVE THE "A", A SUN AND RAINBOW EXTENDING FROM THE TOOTH, THE SUN IN YELLOW, THE RAINBOW IN BLUE, GREEN, YELLOW, AND RED, ENDING IN PILE OF COINS IN GRAY AND YELLOW, FOUR CHILDREN IN ALTERNATING PINK AND BLUE ARE PLAYING ON THE RAINBOW; ALL OF THE FOREGOING IS ABOVE THE TERMS "A+ PEDIATRIC DENTAL SPECIALTY CARE, P.C." IN BLACK.

FOR DENTIST SERVICES (U.S. CLS. 100 AND 101).  
FIRST USE 9-1-2010; IN COMMERCE 9-1-2010.  
HELENE LIWINSKI, EXAMINING ATTORNEY

SN 85-156,352. AMERICAN MANAGEMENT GROUP, LLC, DBA A+ ORTHODONTIC SPECIALTY CARE, P.C., FORT WASHINGTON, PA. FILED 10-19-2010.



NO CLAIM IS MADE TO THE EXCLUSIVE RIGHT TO USE "ORTHO" AND "ORTHODONTIC SPECIALTY CARE, P.C.", APART FROM THE MARK AS SHOWN.

THE COLOR(S) GRAY, WHITE, LILAC, MAGENTA AND BLACK IS/ARE CLAIMED AS A FEATURE OF THE MARK.

THE MARK CONSISTS OF THE STYLIZED TERMS "A+ ORTHO" WITH THE LETTERS IN GRAY AND THE "+" IN MAGENTA, A LILAC TOOTH ABOVE THE "A", AND A SERIES OF WHITE TEETH WITH LILAC BRACES IN THE "O". THE INSIDE OF BOTH "O'S" IN "ORTHO" ALSO BEING HALF GRAY, HALF WHITE, ALL ABOVE THE TERMS "A+ ORTHODONTIC SPECIALTY CARE, P.C." IN BLACK.

FOR DENTIST SERVICES (U.S. CLS. 100 AND 101).  
FIRST USE 9-1-2010; IN COMMERCE 9-1-2010.  
HELENE LIWINSKI, EXAMINING ATTORNEY

SN 85-156,414. AMERICAN MANAGEMENT GROUP, LLC, DBA A+ PERIODONTIC SPECIALTY CARE, P.C., FORT WASHINGTON, PA. FILED 10-19-2010.



NO CLAIM IS MADE TO THE EXCLUSIVE RIGHT TO USE "PERIO" AND "PERIODONTIC SPECIALTY CARE, P.C.", APART FROM THE MARK AS SHOWN.

THE COLOR(S) GRAY, LIME GREEN, BLACK, AND GREEN IS/ARE CLAIMED AS A FEATURE OF THE MARK.

THE MARK CONSISTS OF THE TERMS "A+ PERIO" WITH THE LETTERS IN GRAY, WITH THE PLUS SIGN SHOWN IN GREEN IN A LIME GREEN TOOTH ABOVE THE "A", ALL ABOVE THE TERMS "A+ PERIODONTIC SPECIALTY CARE, P.C." IN BLACK.

FOR DENTIST SERVICES (U.S. CLS. 100 AND 101).  
FIRST USE 9-1-2010; IN COMMERCE 9-1-2010.  
HELENE LIWINSKI, EXAMINING ATTORNEY

**CLASS 44—(Continued).**

SN 85-158,054. LENOX BROTHERS INC., AKA GOT LEAVES?, WESTFORD, MA. FILED 10-21-2010.

## GOT LEAVES?

THE MARK CONSISTS OF STANDARD CHARACTERS WITHOUT CLAIM TO ANY PARTICULAR FONT, STYLE, SIZE, OR COLOR.

FOR LAWN AND GARDEN CARE; LEAF AND BRUSH REMOVAL; LANDSCAPE MAINTENANCE (U.S. CLS. 100 AND 101).

FIRST USE 12-31-2004; IN COMMERCE 12-31-2004.  
LINDSEY RUBIN, EXAMINING ATTORNEY

SN 85-158,621. MASCOLA, ALEX P., TORRANCE, CA. FILED S.R. 10-21-2010; AM. P.R. 2-2-2011.



THE MARK CONSISTS OF AN IMAGE OF A TOOTH CREATED BY REPRESENTATIONS OF TWO ADULTS AND A CHILD HOLDING HANDS.

FOR DENTIST SERVICES; ORTHODONTIC SERVICES (U.S. CLS. 100 AND 101).

FIRST USE 9-15-2010; IN COMMERCE 10-19-2010.  
EVELYN BRADLEY, EXAMINING ATTORNEY

SN 85-158,921. SURROGACY EXPERIENCE, LLC, NEPTUNE, NJ. FILED 10-22-2010.



OWNER OF U.S. REG. NO. 3,905,854.

NO CLAIM IS MADE TO THE EXCLUSIVE RIGHT TO USE "SURROGACY", APART FROM THE MARK AS SHOWN.

THE MARK CONSISTS OF A HEART IN THE CENTER OF A CIRCLE WITH THE WORDING "THE SURROGACY" TO

**CLASS 44—(Continued).**

THE LEFT OF THE HEART IN THE CIRCLE WHERE THE WORD "THE" APPEARS CENTERED ABOVE THE LETTERS "ACY" IN THE WORD "SURROGACY" AND THE WORD "EXPERIENCE" TO THE RIGHT OF THE HEART IN THE CIRCLE. THE WORDING "SURROGACY" AND "EXPERIENCE" ARE OVERLINED AND UNDERLINED. THE WORDING "CONFIDENCE & CARE FROM DECISION TO DELIVERY" IS CENTERED BELOW THE WORDING "THE SURROGACY EXPERIENCE" AND THE HEART AND CIRCLE DESIGN.

FOR MATERNAL SURROGACY SERVICES; CONSULTATION SERVICES IN THE FIELD OF SURROGACY (U.S. CLS. 100 AND 101).

TINA BROWN, EXAMINING ATTORNEY

SN 85-159,480. KINESIOS CORPORATION, MANASSAS, VA. FILED 10-22-2010.

## Kinesios Corporation

THE MARK CONSISTS OF STANDARD CHARACTERS WITHOUT CLAIM TO ANY PARTICULAR FONT, STYLE, SIZE, OR COLOR.

NO CLAIM IS MADE TO THE EXCLUSIVE RIGHT TO USE "CORPORATION", APART FROM THE MARK AS SHOWN.

FOR MEDICAL AND PHARMACEUTICAL CONSULTATION; MEDICAL CONSULTATIONS; MEDICAL CONSULTATIONS PROVIDED VIA PHONE, ONLINE CHAT OR VIDEOCONFERENCING (U.S. CLS. 100 AND 101).  
JAMES GRIFFIN, EXAMINING ATTORNEY

SN 85-161,944. THOMAS E. YOUNG, M.D., LLC, DBA YOUNG MEDICAL SPA, CENTER VALLEY, PA. FILED 10-26-2010.



NO CLAIM IS MADE TO THE EXCLUSIVE RIGHT TO USE "MD" OR "MEDICAL SPA", APART FROM THE MARK AS SHOWN.

THE NAME(S), PORTRAIT(S), AND/OR SIGNATURE(S) SHOWN IN THE MARK IDENTIFIES "THOMAS E. YOUNG, M.D.", WHOSE CONSENT(S) TO REGISTER IS MADE OF RECORD.

THE COLOR(S) MAROON, ORANGE, AND WHITE IS/ARE CLAIMED AS A FEATURE OF THE MARK.

THE MARK CONSISTS OF A MAROON OVAL WITH AN ORANGE PERIMETER AND THE WORDS, ALL IN WHITE, "THOMAS E. YOUNG, MD" ON THE TOP LINE TOWARD THE RIGHT, THE WORD "YOUNG" CENTERED ON THE MIDDLE LINE IN LARGE FONT, AND THE WORDS "MEDICAL SPA" CENTERED ON THE LOWER LINE, WITH A FADED WHITE-TO-ORANGE CURVED LINE BETWEEN THE MIDDLE AND LOWER LINES OF TEXT.

FOR COSMETIC AND PLASTIC SURGERY (U.S. CLS. 100 AND 101).

FIRST USE 10-29-2003; IN COMMERCE 10-29-2003.  
MICHAEL W. BAIRD, EXAMINING ATTORNEY

**CLASS 44—(Continued).**

SN 85-163,526. CANGENE CORPORATION, WINNIPEG, MANITOBA, CANADA, FILED 10-28-2010.



OWNER OF U.S. REG. NOS. 1,609,401, 3,914,492 AND OTHERS.

NO CLAIM IS MADE TO THE EXCLUSIVE RIGHT TO USE "PLASMA RESOURCES MID-FLORIDA", APART FROM THE MARK AS SHOWN.

THE COLOR(S) GRAY AND BLUE IS/ARE CLAIMED AS A FEATURE OF THE MARK.

THE MARK CONSISTS OF THE WORDING "CANGENE PLASMA" IN UPPER CASE GRAY LETTERING OVER THE WORDING "RESOURCES" IN SMALLER UPPER CASE GRAY LETTERING AND THE WORDS "MID-FLORIDA" IN LOWER CASE BLUE LETTERING.

FOR PLASMA SERVICES, NAMELY, BLOOD PLASMA COLLECTION (U.S. CLS. 100 AND 101).

FIRST USE 8-31-2009; IN COMMERCE 8-31-2009.  
FRANK LATTUCA, EXAMINING ATTORNEY

SN 85-163,534. CANGENE CORPORATION, WINNIPEG, MANITOBA, CANADA, FILED 10-28-2010.



OWNER OF U.S. REG. NOS. 1,609,401, 3,914,492 AND OTHERS.

NO CLAIM IS MADE TO THE EXCLUSIVE RIGHT TO USE "PLASMA RESOURCES FREDERICK", APART FROM THE MARK AS SHOWN.

THE COLOR(S) GRAY AND BLUE IS/ARE CLAIMED AS A FEATURE OF THE MARK.

THE MARK CONSISTS OF THE WORDING "CANGENE PLASMA" IN UPPER CASE GRAY LETTERING OVER THE WORDING "RESOURCES" IN SMALLER UPPER CASE GRAY LETTERING AND THE WORDS "FREDERICK" IN LOWER CASE BLUE LETTERING.

FOR PLASMA SERVICES, NAMELY, BLOOD PLASMA COLLECTION (U.S. CLS. 100 AND 101).

FIRST USE 8-31-2009; IN COMMERCE 8-31-2009.  
FRANK LATTUCA, EXAMINING ATTORNEY

SN 85-163,551. CANGENE CORPORATION, WINNIPEG, MANITOBA, CANADA, FILED 10-28-2010.



OWNER OF U.S. REG. NOS. 1,609,401, 3,914,492 AND OTHERS.

NO CLAIM IS MADE TO THE EXCLUSIVE RIGHT TO USE "PLASMA RESOURCES CALIFORNIA", APART FROM THE MARK AS SHOWN.

THE COLOR(S) GRAY AND BLUE IS/ARE CLAIMED AS A FEATURE OF THE MARK.

THE MARK CONSISTS OF THE WORDING "CANGENE PLASMA" IN UPPER CASE GRAY LETTERING OVER THE WORDING "RESOURCES" IN SMALLER UPPER CASE GRAY LETTERING AND THE WORDS "CALIFORNIA" IN LOWER CASE BLUE LETTERING.

FOR PLASMA SERVICES, NAMELY, BLOOD PLASMA COLLECTION (U.S. CLS. 100 AND 101).

FIRST USE 9-30-2009; IN COMMERCE 9-30-2009.  
FRANK LATTUCA, EXAMINING ATTORNEY

**CLASS 44—(Continued).**

SN 85-169,185. GRUPPO PEGASO LLC, NEWPORT COAST, CA. FILED 11-4-2010.



THE MARK CONSISTS OF STANDARD CHARACTERS WITHOUT CLAIM TO ANY PARTICULAR FONT, STYLE, SIZE, OR COLOR.

FOR COUNSELING SERVICES IN THE FIELDS OF HEALTH, HERBALISM, AND LIFESTYLE WELLNESS (U.S. CLS. 100 AND 101).

HEATHER SAPP, EXAMINING ATTORNEY

SN 85-173,617. CENTER FOR APPLICATIONS OF PSYCHOLOGICAL TYPE, INC., GAINESVILLE, FL. FILED 11-10-2010.

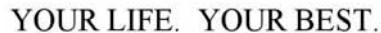

THE MARK CONSISTS OF STANDARD CHARACTERS WITHOUT CLAIM TO ANY PARTICULAR FONT, STYLE, SIZE, OR COLOR.

FOR PROVIDING A WEB SITE IN THE FIELD OF PSYCHOLOGICAL DEVELOPMENT (U.S. CLS. 100 AND 101).

FIRST USE 9-15-2010; IN COMMERCE 9-15-2010.  
ROSELLE HERRERA, EXAMINING ATTORNEY

SN 85-174,226. GRAMERCY RESEARCH GROUP, LLC, WINSTON-SALEM, NC. FILED 11-11-2010.



THE MARK CONSISTS OF STANDARD CHARACTERS WITHOUT CLAIM TO ANY PARTICULAR FONT, STYLE, SIZE, OR COLOR.

FOR COUNSELING AND CONSULTING SERVICES IN THE FIELDS OF HEALTH, WELLNESS AND NUTRITION (U.S. CLS. 100 AND 101).

FIRST USE 3-17-2009; IN COMMERCE 3-27-2009.  
MARK SPARACINO, EXAMINING ATTORNEY



**CLASS 44—(Continued).**

SN 85-176,191. OCCUPRO, LLC, KENOSHA, WI. FILED 11-13-2010.

OccuPro

THE MARK CONSISTS OF STANDARD CHARACTERS WITHOUT CLAIM TO ANY PARTICULAR FONT, STYLE, SIZE, OR COLOR.

FOR OCCUPATIONAL THERAPY SERVICES (U.S. CLS. 100 AND 101).

JAMES GRIFFIN, EXAMINING ATTORNEY

**CLASS 44—(Continued).**

SN 85-178,354. KINETIX LIVING CORP., SEATTLE, WA. FILED 11-16-2010.



THE MARK CONSISTS OF A STYLIZED DESIGN OF THE CAPITAL LETTER "K" FOLLOWED BY A LOWER CASE "X" ALL WITHIN A SQUARE SHAPED DESIGN.

FOR WEIGHT REDUCTION DIET PLANNING AND SUPERVISION THROUGH THE USE OF COUNSELING AND CREATING DIET REGIMES; PROVIDING CONSULTATION SERVICES IN THE FIELDS OF HEALTH-CARE, WEIGHT REDUCTION AND NUTRITION (U.S. CLS. 100 AND 101).

GIANCARLO CASTRO, EXAMINING ATTORNEY

SN 85-176,713. PURINA MILLS, LLC., GRAY SUMMIT, MO. FILED 11-15-2010.

SN 85-178,358. KINETIX LIVING CORP., SEATTLE, WA. FILED 11-16-2010.

Rebel. Ignite. Commit.

THE MARK CONSISTS OF STANDARD CHARACTERS WITHOUT CLAIM TO ANY PARTICULAR FONT, STYLE, SIZE, OR COLOR.

FOR WEIGHT REDUCTION DIET PLANNING AND SUPERVISION THROUGH THE USE OF COUNSELING AND CREATING DIET REGIMES; PROVIDING CONSULTATION SERVICES IN THE FIELDS OF HEALTH-CARE, WEIGHT REDUCTION AND NUTRITION (U.S. CLS. 100 AND 101).

GIANCARLO CASTRO, EXAMINING ATTORNEY

SN 85-178,693. EDUMEDICS, LOUISVILLE, KY. FILED 11-17-2010.

MOVING HEALTHWARD

THE MARK CONSISTS OF THE OUTLINE OF THE TOP OF A HORSE; TAIL, BACK AND HEAD.

FOR PROVIDING INFORMATION IN THE FIELD OF ANIMAL HEALTH AND NUTRITION; NAMELY, EQUINE (U.S. CLS. 100 AND 101).

C. DIONNE CLYBURN, EXAMINING ATTORNEY

THE MARK CONSISTS OF STANDARD CHARACTERS WITHOUT CLAIM TO ANY PARTICULAR FONT, STYLE, SIZE, OR COLOR.

FOR CONSULTING SERVICES IN THE FIELD OF DISEASE AND HEALTH CARE MANAGEMENT (U.S. CLS. 100 AND 101).

DOUGLAS LEE, EXAMINING ATTORNEY

**CLASS 44—(Continued).**

SN 85-178,736. EDUMEDICS LLC, LOUISVILLE, KY. FILED 11-17-2010.

**EDUMEDICS**

THE MARK CONSISTS OF STANDARD CHARACTERS WITHOUT CLAIM TO ANY PARTICULAR FONT, STYLE, SIZE, OR COLOR.

FOR CONSULTING SERVICES IN THE FIELD OF DISEASE AND HEALTH CARE MANAGEMENT (U.S. CLS. 100 AND 101).

CARYN GLASSER, EXAMINING ATTORNEY

SN 85-178,757. MONOGRAM BIOSCIENCES, INC., SOUTH SAN FRANCISCO, CA. FILED 11-17-2010.

**TROPOSEQ**

THE MARK CONSISTS OF STANDARD CHARACTERS WITHOUT CLAIM TO ANY PARTICULAR FONT, STYLE, SIZE, OR COLOR.

FOR MEDICAL TESTING FOR DIAGNOSTIC, PROGNOSTIC OR TREATMENT PURPOSES (U.S. CLS. 100 AND 101).

KATHERINE STOIDES, EXAMINING ATTORNEY

SN 85-179,066. GINGER A. SCHERBARTH, MASON, OH. FILED 11-17-2010.

**MAKE IT HEALTHY!**

THE MARK CONSISTS OF STANDARD CHARACTERS WITHOUT CLAIM TO ANY PARTICULAR FONT, STYLE, SIZE, OR COLOR.

FOR WELLNESS AND HEALTH-RELATED CONSULTING SERVICES (U.S. CLS. 100 AND 101).

FIRST USE 1-1-2007; IN COMMERCE 4-1-2007.

MARGARET POWER, EXAMINING ATTORNEY

**CLASS 44—(Continued).**

SN 85-179,268. HEALTHPER, INC., PRINCETON, NJ. FILED 11-17-2010.

**HEALTHPAD**

THE MARK CONSISTS OF STANDARD CHARACTERS WITHOUT CLAIM TO ANY PARTICULAR FONT, STYLE, SIZE, OR COLOR.

FOR ONLINE SERVICES, NAMELY PROVIDING A WEBSITE DESIGNED TO ENCOURAGE PARTICIPATION IN HEALTH AND WELLNESS PROGRAMS (U.S. CLS. 100 AND 101).

TRACY CROSS, EXAMINING ATTORNEY

SN 85-179,855. NIGHTTIME PEDIATRICS, INC., DAVIDSONVILLE, MD. FILED 11-18-2010.



OWNER OF U.S. REG. NOS. 3,490,520, 3,796,785 AND OTHERS.

THE MARK CONSISTS OF A MOON REPRESENTING A HUMAN FACE AND STARS WITHIN A CIRCLE WITH WAVY LINES CONNECTING SEVERAL OF THE STARS. THE DESIGN ELEMENT APPEARS ABOVE THE LITERAL ELEMENT RIGHTTIME.

FOR MEDICAL SERVICES (U.S. CLS. 100 AND 101).

FIRST USE 1-1-2010; IN COMMERCE 1-1-2010.

PAUL F. GAST, EXAMINING ATTORNEY

SN 85-181,139. MEDTRONIC, INC., MINNEAPOLIS, MN. FILED 11-19-2010.

**FACING OUR MOMENTS TOGETHER**

THE MARK CONSISTS OF STANDARD CHARACTERS WITHOUT CLAIM TO ANY PARTICULAR FONT, STYLE, SIZE, OR COLOR.

FOR PROVIDING MEDICAL INFORMATION RELATING TO BLADDER CONTROL TREATMENT OPTIONS (U.S. CLS. 100 AND 101).

FIRST USE 11-1-2010; IN COMMERCE 11-1-2010.

HEATHER BIDDULPH, EXAMINING ATTORNEY

**CLASS 44—(Continued).**

SN 85-181,170. MEDTRONIC, INC., MINNEAPOLIS, MN.  
FILED 11-19-2010.

IMAGINE EVERYDAY FREEDOM

THE MARK CONSISTS OF STANDARD CHARACTERS WITHOUT CLAIM TO ANY PARTICULAR FONT, STYLE, SIZE, OR COLOR.

FOR PROVIDING MEDICAL INFORMATION RELATING TO BLADDER CONTROL TREATMENT OPTIONS (U.S. CLS. 100 AND 101).

FIRST USE 11-1-2010; IN COMMERCE 11-1-2010.  
HEATHER BIDDULPH, EXAMINING ATTORNEY

SN 85-196,296. QUESTCARE MEDICAL SERVICES, P.A.,  
DALLAS, TX. FILED 12-13-2010.

L5 HEALTHCARE

THE MARK CONSISTS OF STANDARD CHARACTERS WITHOUT CLAIM TO ANY PARTICULAR FONT, STYLE, SIZE, OR COLOR.

NO CLAIM IS MADE TO THE EXCLUSIVE RIGHT TO USE "HEALTHCARE", APART FROM THE MARK AS SHOWN.

FOR MEDICAL SERVICES; PHYSICIAN SERVICES (U.S. CLS. 100 AND 101).  
GINA FINK, EXAMINING ATTORNEY

SN 85-204,206. MEDICIS TECHNOLOGIES CORPORATION,  
BOTHHELL, WA. FILED 12-22-2010.

FAT REDUCTION THAT FITS

THE MARK CONSISTS OF STANDARD CHARACTERS WITHOUT CLAIM TO ANY PARTICULAR FONT, STYLE, SIZE, OR COLOR.

FOR MEDICAL SERVICES, NAMELY, PROCEDURES IN THE NATURE OF BODY CONTOURING AND DECREASING HUMAN BODY FAT (U.S. CLS. 100 AND 101).

ZACHARY BELLO, EXAMINING ATTORNEY

**CLASS 44—(Continued).**

SN 85-204,224. MEDICIS TECHNOLOGIES CORPORATION,  
BOTHHELL, WA. FILED 12-22-2010.

FAT REDUCTION THAT FITS  
YOUR LIFESTYLE

THE MARK CONSISTS OF STANDARD CHARACTERS WITHOUT CLAIM TO ANY PARTICULAR FONT, STYLE, SIZE, OR COLOR.

FOR MEDICAL SERVICES, NAMELY, PROCEDURES IN THE NATURE OF BODY CONTOURING AND DECREASING HUMAN BODY FAT (U.S. CLS. 100 AND 101).

ZACHARY BELLO, EXAMINING ATTORNEY

SN 85-225,166. BEHAVIORAL CENTERS OF AMERICA, LLC,  
NASHVILLE, TN. FILED 1-25-2011.

CART

THE MARK CONSISTS OF STANDARD CHARACTERS WITHOUT CLAIM TO ANY PARTICULAR FONT, STYLE, SIZE, OR COLOR.

FOR MENTAL HEALTH SERVICES (U.S. CLS. 100 AND 101).

NICHOLAS ALTREE, EXAMINING ATTORNEY

**CLASS 45—PERSONAL AND LEGAL SERVICES**

SN 76-705,053. GLANTZ AND GLANTZ, P.A., PLANTATION,  
FL. FILED 10-25-2010.



THE MARK CONSISTS OF A STYLIZED LOWER-CASE LETTER "G" WITHIN A SQUARE, TO THE LEFT OF THE WORDING "GLANTZLAW" ALL OF WHICH IS IN A RECTANGULAR CARRIER.

FOR LEGAL SERVICES (U.S. CLS. 100 AND 101).  
FIRST USE 9-20-2010; IN COMMERCE 9-20-2010.  
DAVID HOFFMAN, EXAMINING ATTORNEY

**CLASS 45—(Continued).**

SN 76-705,196. SACKS TIERNEY P.A., SCOTTSDALE, AZ. FILED 11-2-2010.

## Sacks Tierney P.A.

THE MARK CONSISTS OF STANDARD CHARACTERS WITHOUT CLAIM TO ANY PARTICULAR FONT, STYLE, SIZE, OR COLOR.

NO CLAIM IS MADE TO THE EXCLUSIVE RIGHT TO USE "P.A.", APART FROM THE MARK AS SHOWN. FOR LEGAL SERVICES (U.S. CLS. 100 AND 101). FIRST USE 5-10-1994; IN COMMERCE 5-10-1994. ROBERT STRUCK, EXAMINING ATTORNEY

SN 77-950,377. FEENGO, INC, ROSEDALE, NY. FILED 3-4-2010.

feengo  
your global network

THE MARK CONSISTS OF STANDARD CHARACTERS WITHOUT CLAIM TO ANY PARTICULAR FONT, STYLE, SIZE, OR COLOR.

NO CLAIM IS MADE TO THE EXCLUSIVE RIGHT TO USE "YOUR GLOBAL NETWORK", APART FROM THE MARK AS SHOWN.

FOR INTERNET-BASED SOCIAL NETWORKING SERVICES; ON-LINE SOCIAL NETWORKING SERVICES; ONLINE SOCIAL NETWORKING SERVICES PROVIDED THROUGH A FASHION COMMUNITY WEBSITE; ON-LINE SOCIAL NETWORKING SERVICES PROVIDED THROUGH A SPORTS COMMUNITY WEBSITE; PROVIDING A SOCIAL NETWORKING WEBSITE FOR ENTERTAINMENT PURPOSES (U.S. CLS. 100 AND 101).

FIRST USE 1-26-2010; IN COMMERCE 1-26-2010. DAVID TOOLEY, EXAMINING ATTORNEY

**CLASS 45—(Continued).**

SN 85-016,990. BUMBLEBEE PERSONAL ASSISTANTS, LLC, WHITE BEAR LAKE, MN. FILED 4-19-2010.



NO CLAIM IS MADE TO THE EXCLUSIVE RIGHT TO USE "PERSONAL ASSISTANTS", APART FROM THE MARK AS SHOWN.

THE COLOR(S) BLACK, BROWN, YELLOW AND BLUE IS/ARE CLAIMED AS A FEATURE OF THE MARK.

THE MARK CONSISTS OF THE WORDING "BUMBLEBEE PERSONAL ASSISTANTS" WITH A DESIGN. THE WORDING "BUMBLEBEE PERSONAL ASSISTANTS" APPEARS IN BLACK. THE FIRST "B" IN "BUMBLEBEE" RESEMBLES A BEE THAT IS SHADED YELLOW WITH A BROWN STRIPE AND BLACK EYE. THE BEE HAS A BLUE WING FOLLOWED BY BLUE DASHES.

FOR PROVIDING NON-MEDICAL PERSONAL ASSISTANT SERVICES FOR OTHERS IN THE NATURE OF PLANNING, ORGANIZING, COORDINATING, ARRANGING AND ASSISTING INDIVIDUALS TO PERFORM DAILY TASKS (U.S. CLS. 100 AND 101).

FIRST USE 8-13-2007; IN COMMERCE 8-13-2007. INGRID C. EULIN, EXAMINING ATTORNEY

SN 85-020,605. EMBRACE YOUR GREATNESS, INC., CAPITOL HEIGHTS, MD. FILED 4-22-2010.

## EMBRACE YOUR GREATNESS

THE MARK CONSISTS OF STANDARD CHARACTERS WITHOUT CLAIM TO ANY PARTICULAR FONT, STYLE, SIZE, OR COLOR.

FOR PERSONAL GROWTH AND MOTIVATION CONSULTING SERVICES (U.S. CLS. 100 AND 101).

FIRST USE 4-1-2007; IN COMMERCE 4-1-2007. LINDA ESTRADA, EXAMINING ATTORNEY

SN 85-021,928. SPEED CHANNEL, INC., LOS ANGELES, CA. FILED 4-23-2010.

## SPEED.COM

THE MARK CONSISTS OF STANDARD CHARACTERS WITHOUT CLAIM TO ANY PARTICULAR FONT, STYLE, SIZE, OR COLOR.

FOR INTERNET BASED INTRODUCTION AND SOCIAL NETWORKING SERVICES; PROVIDING ON-LINE COMPUTER DATABASES AND ON-LINE SEARCHABLE DATABASES IN THE FIELD OF SOCIAL NETWORKING (U.S. CLS. 100 AND 101).

JULIE WATSON, EXAMINING ATTORNEY

**CLASS 45—(Continued).**

SN 85-043,499. HUMANBOOK, INC., WELLESLEY HILLS, MA. FILED 5-20-2010.

# Radaris

THE MARK CONSISTS OF STANDARD CHARACTERS WITHOUT CLAIM TO ANY PARTICULAR FONT, STYLE, SIZE, OR COLOR.

FOR PUBLIC RECORD INVESTIGATION SERVICES AND BACKGROUND INVESTIGATION AND RESEARCH SERVICES FOR CONSUMERS AND BUSINESSES VIA A GLOBAL COMPUTER NETWORK (U.S. CLS. 100 AND 101).

FIRST USE 4-22-2008; IN COMMERCE 4-22-2008.  
STEVEN JACKSON, EXAMINING ATTORNEY

---

SN 85-044,518. SCHMITTER, YVETTE, MANHASSET, NY. FILED 5-21-2010.

# ONLINE DATING DIVA

THE MARK CONSISTS OF STANDARD CHARACTERS WITHOUT CLAIM TO ANY PARTICULAR FONT, STYLE, SIZE, OR COLOR.

NO CLAIM IS MADE TO THE EXCLUSIVE RIGHT TO USE "ONLINE DATING", APART FROM THE MARK AS SHOWN.

FOR PERSONAL AND SOCIAL SERVICES, NAMELY, PROVIDING A WEBSITE FEATURING INTERNET DATING TIPS AND INFORMATION (U.S. CLS. 100 AND 101).  
AMY C. KEAN, EXAMINING ATTORNEY

---

SN 85-048,521. NATIONAL RIFLE ASSOCIATION OF AMERICA, FAIRFAX, VA. FILED 5-26-2010.

# NRA COUNTRY

THE MARK CONSISTS OF STANDARD CHARACTERS WITHOUT CLAIM TO ANY PARTICULAR FONT, STYLE, SIZE, OR COLOR.

OWNER OF U.S. REG. NOS. 1,875,619, 1,939,923 AND OTHERS.

NO CLAIM IS MADE TO THE EXCLUSIVE RIGHT TO USE "COUNTRY", APART FROM THE MARK AS SHOWN.

FOR PROVIDING INFORMATION ABOUT COUNTRY AND RURAL LIFESTYLES AND VALUES, SUCH AS PATRIOTISM AND FREEDOM; PROVIDING INFORMATION RELATING TO LEGAL AFFAIRS; PROVIDING INFORMATION ABOUT FIREARM SAFETY (U.S. CLS. 100 AND 101).

FIRST USE 10-31-2009; IN COMMERCE 10-31-2009.  
ALLISON SCHRODY, EXAMINING ATTORNEY

**CLASS 45—(Continued).**

SN 85-079,417. STOKES AND ASSOCIATES LLC, DENVER, CO. FILED 7-7-2010.

# TRAZARO

THE MARK CONSISTS OF STANDARD CHARACTERS WITHOUT CLAIM TO ANY PARTICULAR FONT, STYLE, SIZE, OR COLOR.

THE ENGLISH TRANSLATION OF "TRAZARO" IN THE MARK IS "I TRACE".

FOR PROVIDING A WEBSITE FOR TRACKING ANIMALS AND PROVIDING ANIMAL TRACKING INFORMATION MANAGEMENT SOLUTION THAT ENABLES FOOD COMPANIES TO TRACK FOOD ANIMALS AND FOOD ANIMAL PRODUCTS THROUGH THE SUPPLY CHAIN (U.S. CLS. 100 AND 101).

CHRISTINA SOBRAL, EXAMINING ATTORNEY

---

SN 85-100,805. LEONOR L. RAMIREZ, TINLEY PARK, IL. AND BOUSSARI, MOYOSSOLA J., RICHTON PARK, IL. FILED 8-5-2010.

# TURN TO HIM

THE MARK CONSISTS OF STANDARD CHARACTERS WITHOUT CLAIM TO ANY PARTICULAR FONT, STYLE, SIZE, OR COLOR.

FOR RELIGIOUS MINISTRY SERVICES, NAMELY, ORGANIZING AND CONDUCTING SPIRITUAL GATHERINGS, RETREATS, AND PRAYER MEETINGS (U.S. CLS. 100 AND 101).

FIRST USE 7-21-2010; IN COMMERCE 7-21-2010.  
DEIRDRE ROBERTSON, EXAMINING ATTORNEY

**CLASS 45—(Continued).**

SN 85-113,094. DUE SEASON MINISTRIES INTERNATIONAL, DBA DUE SEASON MINISTRIES INTERNATIONAL, DAYTON, OH. FILED 8-22-2010.

**DUE SEASON MINISTRIES  
INTERNATIONAL**

THE MARK CONSISTS OF STANDARD CHARACTERS WITHOUT CLAIM TO ANY PARTICULAR FONT, STYLE, SIZE, OR COLOR.

NO CLAIM IS MADE TO THE EXCLUSIVE RIGHT TO USE "MINISTRIES INTERNATIONAL", APART FROM THE MARK AS SHOWN.

FOR CHRISTIAN MINISTRY SERVICES; COUNSELING SERVICES IN THE FIELD OF CHRISTIAN CONDUCT IN PERSONAL RELATIONSHIPS; PROVIDING A WEBSITE FEATURING INFORMATION FOR LOCAL CHURCH LEADERS IN THE FIELD OF CHRISTIAN GROWTH (U.S. CLS. 100 AND 101).

FIRST USE 8-1-2007, THE MARK WAS FIRST USED ANYWHERE IN A DIFFERENT FORM OTHER THAN THAT SOUGHT TO BE REGISTERED AT LEAST AS EARLY AS 07/01/2007.; IN COMMERCE 8-1-2008, THE MARK WAS FIRST USED IN COMMERCE IN A DIFFERENT FORM OTHER THAN THAT SOUGHT TO BE REGISTERED AT LEAST AS EARLY AS 08/01/2008..

JESSICA FATHY, EXAMINING ATTORNEY

SN 85-121,478. HOME MISSION SISTERS OF AMERICA, INC., OWENSBORO, KY. FILED 9-2-2010.



THE MARK CONSISTS OF A STAR DESIGN, FOR MISSIONARY SERVICES, NAMELY, EVANGELISTIC MINISTERIAL SERVICES (U.S. CLS. 100 AND 101).

FIRST USE 7-0-1976; IN COMMERCE 7-0-1976.  
SUSAN LESLIE DUBOIS, EXAMINING ATTORNEY

**CLASS 45—(Continued).**

SN 85-125,980. MEMORIALME INC, NEWARK, DE. FILED 9-9-2010.

**memorialME**

THE MARK CONSISTS OF STANDARD CHARACTERS WITHOUT CLAIM TO ANY PARTICULAR FONT, STYLE, SIZE, OR COLOR.

FOR ON-LINE SOCIAL NETWORKING FOR COMMEMORATING AND MEMORIALIZING THE DECEASED AND ALLOWING INDIVIDUALS TO PLAN THEIR OWN FUNERAL ARRANGEMENTS VIRTUALLY (U.S. CLS. 100 AND 101).

NAKIA HENRY, EXAMINING ATTORNEY

SN 85-129,255. AMAZING KARMA, LLC, TOLUCA LAKE, CA. FILED 9-14-2010.



**AMAZINGKARMA.COM**

THE MARK CONSISTS OF THE STYLIZED LETTERING, "AMAZINGKARMA.COM", WITH A STYLIZED HUMAN FIGURE ABOVE IT.

FOR PROVIDING A WEBSITE THAT ENCOURAGES AND ACKNOWLEDGES RANDOM ACTS OF KINDNESS AND COURTESY (U.S. CLS. 100 AND 101).

FIRST USE 9-10-2010; IN COMMERCE 9-10-2010.

KEVON CHISOLM, EXAMINING ATTORNEY

SN 85-131,293. C.J. ADVERTISING, LLC, NASHVILLE, TN. FILED 9-16-2010.



NO CLAIM IS MADE TO THE EXCLUSIVE RIGHT TO USE "TALK TO A NURSE", APART FROM THE MARK AS SHOWN.

THE COLOR(S) BLUE, WHITE, GRAY AND RED IS/ARE CLAIMED AS A FEATURE OF THE MARK.

THE MARK CONSISTS OF A BLUE DIALOGUE BALLOON WITH THE WORD "TALK" APPEARING IN WHITE INSIDE THE DIALOGUE BALLOON AND THE WORDS "TO A" APPEARING IN GRAY STACKED TO THE RIGHT OF THE DIALOGUE BALLOON FOLLOWED BY THE TERM "NURSE" APPEARING IN RED.

FOR LEGAL SERVICES (U.S. CLS. 100 AND 101).

FIRST USE 9-30-2010; IN COMMERCE 9-30-2010.

ASMAT KHAN, EXAMINING ATTORNEY

**CLASS 45—(Continued).**

SN 85-132,172. UNIREGISTRY, CORP, GRAND CAYMAN, CAYMAN ISLANDS, FILED 9-17-2010.

**UNIREGISTRY**

THE MARK CONSISTS OF STANDARD CHARACTERS WITHOUT CLAIM TO ANY PARTICULAR FONT, STYLE, SIZE, OR COLOR.

FOR DOMAIN NAME REGISTRY SERVICES, NAMELY, COORDINATING THE REGISTRATION OF DOMAIN NAMES ON THE INTERNET; PROVIDING AN ONLINE COMPUTER DATABASE IN THE FIELD OF DOMAIN NAME REGISTRATION INFORMATION (U.S. CLS. 100 AND 101).

MARTHA SANTOMARTINO, EXAMINING ATTORNEY

SN 85-137,188. ALL AMERICAN PROTECTIVE SERVICES, LLC, ROCKVILLE, MD. FILED 9-24-2010.



THE COLOR(S) BLACK, BLUE, WHITE AND SILVER IS/ ARE CLAIMED AS A FEATURE OF THE MARK.

THE MARK CONSISTS OF A FINGERPRINT IN BLACK COLOR ON A BLUE BACKGROUND WITH WHITE LINES, WITHIN A SILVER CIRCLE THAT HAS A SHINE EFFECT. THE OUTER CIRCULAR BORDER OF THE MARK IS BLUE. AT THE BOTTOM OF THE MARK IS A SILVER SHADOW.

FOR PROVIDING PERSONAL BACKGROUND SCREENING SERVICES AND PERSONAL BACKGROUND INVESTIGATIONS; BIOMETRIC EQUIPMENT SERVICES, NAMELY, MONITORING OF BIOMETRIC EQUIPMENT FOR SECURITY PURPOSES, FINGERPRINTING SERVICES, AND MOBILE FINGERPRINTING SERVICES (U.S. CLS. 100 AND 101).

KIMBERLY FRYE, EXAMINING ATTORNEY

SN 85-141,005. STEPHEN N. BARNES, JR., LLC, MACON, GA. FILED 9-29-2010.

**TRUST.INNOVATION.PEACE.**

THE MARK CONSISTS OF STANDARD CHARACTERS WITHOUT CLAIM TO ANY PARTICULAR FONT, STYLE, SIZE, OR COLOR.

FOR LEGAL SERVICES (U.S. CLS. 100 AND 101).

FIRST USE 3-1-2010; IN COMMERCE 3-1-2010.

ELI HELLMAN, EXAMINING ATTORNEY

**CLASS 45—(Continued).**

SN 85-144,773. SPIRITUAL CARE SERVICES, LLC, MOOR-ESBORO, NC. FILED 10-4-2010.

**TeleSpiritual Care**

THE MARK CONSISTS OF STANDARD CHARACTERS WITHOUT CLAIM TO ANY PARTICULAR FONT, STYLE, SIZE, OR COLOR.

NO CLAIM IS MADE TO THE EXCLUSIVE RIGHT TO USE "CARE", APART FROM THE MARK AS SHOWN.

FOR TELESPIRITUAL CARE IS SPIRITUAL CARE SERVICES, NAMELY, SPIRITUAL COUNSELING PROVIDED ONLINE, AND VIA EMAIL, VOIP, AND INSTANT MESSAGE (U.S. CLS. 100 AND 101).

FIRST USE 2-1-2010; IN COMMERCE 10-1-2010.

PATRICIA EVANKO, EXAMINING ATTORNEY

SN 85-146,108. 742 COMMERCIAL, INC., SAN DIEGO, CA. FILED 10-6-2010.

**HER CATWALK**

THE MARK CONSISTS OF STANDARD CHARACTERS WITHOUT CLAIM TO ANY PARTICULAR FONT, STYLE, SIZE, OR COLOR.

NO CLAIM IS MADE TO THE EXCLUSIVE RIGHT TO USE "CATWALK", APART FROM THE MARK AS SHOWN.

FOR PROVIDING AN ONLINE INTERACTIVE WEB SITE FEATURING FASHION INFORMATION AND FASHION CONSULTING INFORMATION (U.S. CLS. 100 AND 101).

STEVEN R. FINE, EXAMINING ATTORNEY

SN 85-148,601. GET ORGANIZED, LLC, MARSHFIELD, MO. FILED 10-8-2010.



NO CLAIM IS MADE TO THE EXCLUSIVE RIGHT TO USE "ORGANIZED", APART FROM THE MARK AS SHOWN.

THE MARK CONSISTS OF THE MARK "2B ORGANIZED" IN A STYLIZED FORM WITHIN AN OVAL WHEREIN THE "O" IS IN-FILLED WITH CONCENTRIC RINGS OF EVENLY SPACED DOTS."

FOR PROVIDING ORGANIZING SERVICES FOR INDIVIDUALS AT HOME, IN HOME OFFICES, AND IN BUSINESS OFFICES, NAMELY, BASEMENTS, ATTICS, STORAGE ROOMS, CLOSETS, GARAGES, KITCHENS, PANTRIES, UTILITY ROOMS, DESKS, FILES, WORKSPACES, PLAYROOMS, DOCUMENT MANAGEMENT, AND ORGANIZING BELONGINGS FOR HOUSEHOLD MOVES (U.S. CLS. 100 AND 101).

FIRST USE 3-31-2010; IN COMMERCE 5-31-2010.

CAROLINE WOOD, EXAMINING ATTORNEY

**CLASS 45—(Continued).**

SN 85-148,614. GET ORGANIZED, LLC, MARSHFIELD, MO. FILED 10-8-2010.

**2B ORGANIZED**

THE MARK CONSISTS OF STANDARD CHARACTERS WITHOUT CLAIM TO ANY PARTICULAR FONT, STYLE, SIZE, OR COLOR.

NO CLAIM IS MADE TO THE EXCLUSIVE RIGHT TO USE "ORGANIZED", APART FROM THE MARK AS SHOWN.

FOR PROVIDING ORGANIZING SERVICES FOR INDIVIDUALS AT HOME, IN HOME OFFICES, AND IN BUSINESS OFFICES, NAMELY, BASEMENTS, ATTICS, STORAGE ROOMS, CLOSETS, GARAGES, KITCHENS, PANTRIES, UTILITY ROOMS, DESKS, FILES, WORKSPACES, PLAYROOMS, DOCUMENT MANAGEMENT, AND ORGANIZING BELONGINGS FOR HOUSEHOLD MOVES (U.S. CLS. 100 AND 101).

FIRST USE 3-31-2010; IN COMMERCE 5-31-2010.  
CAROLINE WOOD, EXAMINING ATTORNEY

---

SN 85-154,780. MENZIES, LAURIE L., BUFFALO, NY. AND BEINHAUER, CHARLES W., BUFFALO, NY. FILED 10-18-2010.

**COUNSEL FOR GENERATIONS**

THE MARK CONSISTS OF STANDARD CHARACTERS WITHOUT CLAIM TO ANY PARTICULAR FONT, STYLE, SIZE, OR COLOR.

NO CLAIM IS MADE TO THE EXCLUSIVE RIGHT TO USE "COUNSEL", APART FROM THE MARK AS SHOWN.

FOR LEGAL SERVICES (U.S. CLS. 100 AND 101).  
FIRST USE 10-1-2004; IN COMMERCE 11-1-2004.

MATTHEW KLINE, EXAMINING ATTORNEY

---

SN 85-155,460. MOHR, DAVID, BELLEVUE, WA. FILED 10-18-2010.

**THE GOOD GUY CLUB**

THE MARK CONSISTS OF STANDARD CHARACTERS WITHOUT CLAIM TO ANY PARTICULAR FONT, STYLE, SIZE, OR COLOR.

NO CLAIM IS MADE TO THE EXCLUSIVE RIGHT TO USE "CLUB", APART FROM THE MARK AS SHOWN.

FOR COUNSELING IN THE FIELD OF PERSONAL DEVELOPMENT, NAMELY, SELF-IMPROVEMENT, SELF-FULFILLMENT, AND INTERPERSONAL COMMUNICATION; ORGANIZING AND CONDUCTING SUPPORT GROUPS IN THE FIELD OF CONFLICT MANAGEMENT (U.S. CLS. 100 AND 101).

FIRST USE 1-2-2008; IN COMMERCE 1-2-2008.

DOMINICK J. SALEMI, EXAMINING ATTORNEY

**CLASS 45—(Continued).**

SN 85-156,306. DIANE COOPER TIMMERMAN, DBA THE HEAVEN HOUSE, OKLAHOMA CITY, OK. FILED 10-19-2010.

**Heaven House**

THE MARK CONSISTS OF STANDARD CHARACTERS WITHOUT CLAIM TO ANY PARTICULAR FONT, STYLE, SIZE, OR COLOR.

NO CLAIM IS MADE TO THE EXCLUSIVE RIGHT TO USE "HOUSE", APART FROM THE MARK AS SHOWN.

FOR PERSONAL CARE ASSISTANCE OF ACTIVITIES OF DAILY LIVING, SUCH AS BATHING, GROOMING AND PERSONAL MOBILITY FOR MENTALLY OR PHYSICALLY CHALLENGED PEOPLE (U.S. CLS. 100 AND 101).

FIRST USE 8-1-2010; IN COMMERCE 8-1-2010.

MARK SHINER, EXAMINING ATTORNEY

---

SN 85-156,605. ADT SERVICES AG, SCHAFFHAUSEN, SWITZERLAND, FILED 10-20-2010.

**ADT PULSE**

THE MARK CONSISTS OF STANDARD CHARACTERS WITHOUT CLAIM TO ANY PARTICULAR FONT, STYLE, SIZE, OR COLOR.

OWNER OF U.S. REG. NOS. 700,676, 3,909,665 AND OTHERS.

FOR ALARM RESPONSE AND VERIFICATION SERVICES; MONITORING OF ALARMS, SECURITY SYSTEMS AND HOME AUTOMATION SYSTEMS FOR SECURITY PURPOSES; REMOTE MONITORING OF ALARMS, SECURITY SYSTEMS AND HOME AUTOMATION SYSTEMS FOR SECURITY PURPOSES; MONITORING OF COMPUTER SYSTEMS FOR SECURITY PURPOSES, NAMELY, REMOTE MONITORING OF COMPUTER SYSTEMS IN THE FIELDS OF SECURITY SYSTEMS, FIRE ALARMS, ALARM CENTRAL UNITS, ANTI-INTRUSION ALARMS, BURGLAR ALARMS, PERSONAL HEALTH AND SECURITY ALARMS, SMOKE AND GAS ALARMS, HOME SURVEILLANCE SYSTEMS, LIGHTING CONTROLS, HOME AUTOMATION DEVICES, SPRINKLER SYSTEMS FOR FIRE PROTECTION, VEHICLE, PET AND PERSONNEL LOCATION, AUTOMOBILE SAFETY, VEHICLE THEFT, TRAFFIC, AND ROAD NAVIGATION, ALL OF THE FOREGOING FOR SECURITY PURPOSES; FIRE ALARM SPRINKLER AND WATER FLOW MONITORING SERVICES FOR FIRE ALARM SECURITY PURPOSES; CONTROL OF BUILDING ENVIRONMENTAL ACCESS AND SECURITY SYSTEMS; MONITORING TELEPHONE CALLS FROM SUBSCRIBERS AND NOTIFYING EMERGENCY FACILITIES; THEFT RECOVERY SERVICES, NAMELY, TRACKING, LOCATING AND MONITORING OF VEHICLES VIA A COMPUTER NETWORK; ELECTRONIC MONITORING SERVICES FOR SECURITY PURPOSES IN THE FIELD OF PETS, HOMES, PEOPLE AND BUSINESS BUILDINGS; PROVIDING SECURITY CONSULT-



**CLASS 45—(Continued).**

ING AND SECURITY CONSULTING VIA TELEPHONE HOTLINE; MONITORING TELEPHONE CALLS AND MESSAGES FROM SUBSCRIBERS AND NOTIFYING EMERGENCY FACILITIES FROM CALL CENTERS IN THE FIELDS OF SECURITY SYSTEMS, FIRE ALARMS, ALARM CENTRAL UNITS, ANTI-INTRUSION ALARMS, BURGLAR ALARMS, PERSONAL HEALTH AND SECURITY ALARMS, SMOKE AND GAS ALARMS, HOME SURVEILLANCE SYSTEMS, LIGHTING CONTROLS, HOME AUTOMATION DEVICES AND SPRINKLER SYSTEMS FOR FIRE PROTECTION; PROVIDING SECURITY CONSULTING VIA TELEPHONE HOTLINE AND MONITORING TELEPHONE CALLS FROM SUBSCRIBERS AND NOTIFYING EMERGENCY FACILITIES FROM CALL CENTERS IN THE FIELDS OF VEHICLE SECURITY AND NAVIGATION; AND CONCIERGE SERVICES FOR OTHERS COMPRISING MAKING REQUESTED PERSONAL ARRANGEMENTS AND RESERVATIONS AND PROVIDING CUSTOMER-SPECIFIC INFORMATION TO MEET INDIVIDUAL NEEDS (U.S. CLS. 100 AND 101).

KAREN K. BUSH, EXAMINING ATTORNEY

SN 85-173,491. HUMAN2, INC., DBA GOTRUSTED, STUART, FL. FILED 11-10-2010.

**Mr. TMI**

THE MARK CONSISTS OF STANDARD CHARACTERS WITHOUT CLAIM TO ANY PARTICULAR FONT, STYLE, SIZE, OR COLOR.

FOR PROVIDING INFORMATION IN THE FIELD OF BUILDING SECURITY VIA THE INTERNET (U.S. CLS. 100 AND 101).

BRENDAN REGAN, EXAMINING ATTORNEY

SN 85-173,633. CENTER FOR APPLICATIONS OF PSYCHOLOGICAL TYPE, INC., GAINESVILLE, FL. FILED 11-10-2010.

**YOUR LIFE. YOUR BEST.**

THE MARK CONSISTS OF STANDARD CHARACTERS WITHOUT CLAIM TO ANY PARTICULAR FONT, STYLE, SIZE, OR COLOR.

FOR PROVIDING A WEB SITE FEATURING INFORMATION IN THE FIELDS OF HUMAN PERSONALITY AND RELATIONSHIPS AND PERSONAL GROWTH DEVELOPMENT (U.S. CLS. 100 AND 101).

FIRST USE 9-15-2010; IN COMMERCE 9-15-2010.  
ROSELLE HERRERA, EXAMINING ATTORNEY

**CLASS 45—(Continued).**

SN 85-176,509. KAROL, HAUSMAN, SOSNIK & FINCHUM, LLP, CLEARWATER, FL. FILED 11-15-2010.

**Navigating Life's Greatest Challenges**

THE MARK CONSISTS OF STANDARD CHARACTERS WITHOUT CLAIM TO ANY PARTICULAR FONT, STYLE, SIZE, OR COLOR.

FOR LEGAL SERVICES (U.S. CLS. 100 AND 101).  
FIRST USE 11-1-2010; IN COMMERCE 11-1-2010.  
JOHN WILKE, EXAMINING ATTORNEY

SN 85-176,554. MILLS III, FLOYD SIMPSON, AKA TREY MILLS, GREENVILLE, SC. FILED 11-15-2010.

**Would You Take Advice from the Devil on How to Get to Heaven?**

THE MARK CONSISTS OF STANDARD CHARACTERS WITHOUT CLAIM TO ANY PARTICULAR FONT, STYLE, SIZE, OR COLOR.

FOR PERSONAL GROWTH AND MOTIVATION CONSULTING SERVICES (U.S. CLS. 100 AND 101).

JOHN DALIER, EXAMINING ATTORNEY

SN 85-176,598. ANDRUS, SCEALES, STARKE & SAWALL, LLP, MILWAUKEE, WI. FILED 11-15-2010.

**CONSIDER YOUR INTELLECTUAL PROPERTY SECURE**

THE MARK CONSISTS OF STANDARD CHARACTERS WITHOUT CLAIM TO ANY PARTICULAR FONT, STYLE, SIZE, OR COLOR.

FOR LEGAL SERVICES (U.S. CLS. 100 AND 101).  
FIRST USE 2-22-2008; IN COMMERCE 2-22-2008.  
VIVIAN MICZNIK FIRST, EXAMINING ATTORNEY

**CLASS 45—(Continued).**

SN 85-176,601. MICHAEL HAYNES PLC, KESWICK, VA. FILED 11-15-2010.

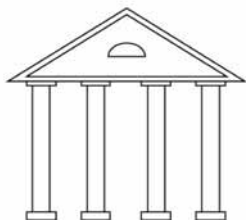

THE MARK CONSISTS OF A DESIGN ELEMENT FEATURING 4 SUBSTANTIALLY EQUALLY-DISTRIBUTED COLUMNS SUPPORTING A TRIANGULAR GABLE, THE GABLE HAVING A SUBSTANTIALLY CENTERED SEMI-ELLIPTICAL WINDOW.

FOR LEGAL SERVICES (U.S. CLS. 100 AND 101).  
VIVIAN MICZNIK FIRST, EXAMINING ATTORNEY

SN 85-176,628. BURDA, DOUGLAS, LAS VEGAS, NV. FILED 11-15-2010.

**KONCEPT**

THE MARK CONSISTS OF STANDARD CHARACTERS WITHOUT CLAIM TO ANY PARTICULAR FONT, STYLE, SIZE, OR COLOR.

FOR LEGAL SERVICES (U.S. CLS. 100 AND 101).  
FIRST USE 6-12-2010; IN COMMERCE 6-12-2010.  
CARYN GLASSER, EXAMINING ATTORNEY

SN 85-177,210. GLEASON, ZINA, FULLERTON, CA. FILED 11-15-2010.



THE STIPLING IS FOR SHADING PURPOSES ONLY. THE MARK CONSISTS OF THE "G" IN "REDEFINING" AND THE "D" IN "DIVORCE" OVERLAP, THE LOGO IS ALL LOWER CAPS, "THE AMICABLE WAY" IN SMALLER PRINT BELOW "REDEFINING DIVORCE", AND THE BACKGROUND IS A LOTUS FLOWER IN A LILLY PAD POND WITH WATER.

FOR MEDIATION (U.S. CLS. 100 AND 101).  
FIRST USE 9-1-2009; IN COMMERCE 9-1-2009.  
LINDA ORNDORFF, EXAMINING ATTORNEY

**CLASS 45—(Continued).**

SN 85-177,404. TED MARTIN SICHELMAN, SAN DIEGO, CA. AND JESSICA MARIE KETEVECS, SAN DIEGO, CA. FILED 11-16-2010.

**FaceDate**

THE MARK CONSISTS OF STANDARD CHARACTERS WITHOUT CLAIM TO ANY PARTICULAR FONT, STYLE, SIZE, OR COLOR.

FOR DATING SERVICES, NAMELY, PROVIDING AN ON-LINE COMPUTER DATABASE FEATURING SINGLE PEOPLE INTERESTED IN MEETING OTHER SINGLE PEOPLE; INTERNET BASED SOCIAL NETWORKING, INTRODUCTION, AND DATING SERVICES; INTERNET-BASED DATING, SOCIAL INTRODUCTION AND SOCIAL NETWORKING SERVICES; MARRIAGE PARTNER INTRODUCTION OR DATING SERVICES; ON-LINE SOCIAL NETWORKING SERVICES; PROVIDING A SOCIAL NETWORKING WEBSITE FOR ENTERTAINMENT PURPOSES; PROVIDING ON-LINE COMPUTER DATABASES AND ON-LINE SEARCHABLE DATABASES IN THE FIELD OF SOCIAL NETWORKING (U.S. CLS. 100 AND 101).

MAYUR VAGHANI, EXAMINING ATTORNEY

SN 85-177,436. SACKETT, GINA, ROBERTS, WI. FILED 11-16-2010.

**Same Page**

THE MARK CONSISTS OF STANDARD CHARACTERS WITHOUT CLAIM TO ANY PARTICULAR FONT, STYLE, SIZE, OR COLOR.

FOR CONDUCTING ON-LINE PERSONAL LIFESTYLE PERFORMANCE ASSESSMENTS BASED ON PRINCIPLES OF EMOTIONAL HAPPINESS BY MEANS OF THE USERS' INPUTTED PREFERENCES AND SOCIAL NETWORK; INTERNET BASED SOCIAL NETWORKING, INTRODUCTION, AND DATING SERVICES; INTERNET-BASED DATING, SOCIAL INTRODUCTION AND SOCIAL NETWORKING SERVICES; INTERNET-BASED SOCIAL NETWORKING SERVICES; ON-LINE SOCIAL NETWORKING SERVICES (U.S. CLS. 100 AND 101).

WENDY JUN, EXAMINING ATTORNEY

SN 85-177,821. CREDIBILITY CORP., MALIBU, CA. FILED 11-16-2010.

**CREDIBILITY**

THE MARK CONSISTS OF STANDARD CHARACTERS WITHOUT CLAIM TO ANY PARTICULAR FONT, STYLE, SIZE, OR COLOR.

FOR FRAUD AND IDENTITY THEFT PROTECTION SERVICES (U.S. CLS. 100 AND 101).

DAVID H. STINE, EXAMINING ATTORNEY

**CLASS 45—(Continued).**

SN 85-177,870. CREDIBILITY CORP., MALIBU, CA. FILED 11-16-2010.

# CREDITAS

THE MARK CONSISTS OF STANDARD CHARACTERS WITHOUT CLAIM TO ANY PARTICULAR FONT, STYLE, SIZE, OR COLOR.

FOR FRAUD AND IDENTITY THEFT PROTECTION SERVICES (U.S. CLS. 100 AND 101).  
DAVID H. STINE, EXAMINING ATTORNEY

---

SN 85-178,110. THE HUNT LAW FIRM, P.C., ST. LOUIS, MO. FILED 11-16-2010.

# LAYER CAKE METHOD

THE MARK CONSISTS OF STANDARD CHARACTERS WITHOUT CLAIM TO ANY PARTICULAR FONT, STYLE, SIZE, OR COLOR.

NO CLAIM IS MADE TO THE EXCLUSIVE RIGHT TO USE "METHOD", APART FROM THE MARK AS SHOWN. FOR LEGAL SERVICES (U.S. CLS. 100 AND 101).  
FIRST USE 6-0-2010; IN COMMERCE 6-0-2010.  
JANICE KIM, EXAMINING ATTORNEY

---

SN 85-178,233. FACEBARKK, POUND RIDGE, NY. FILED 11-16-2010.

# faceBARKK

THE MARK CONSISTS OF STANDARD CHARACTERS WITHOUT CLAIM TO ANY PARTICULAR FONT, STYLE, SIZE, OR COLOR.

FOR PROVIDING A SOCIAL NETWORKING WEBSITE FOR ENTERTAINMENT PURPOSES (U.S. CLS. 100 AND 101).  
WENDY JUN, EXAMINING ATTORNEY

**CLASS 45—(Continued).**

SN 85-178,529. NIGEL C. HEWITT, DBA DASWUSSUP.COM, BROOKLYN, NY. FILED 11-17-2010.

# DASWUSSUP

THE MARK CONSISTS OF STANDARD CHARACTERS WITHOUT CLAIM TO ANY PARTICULAR FONT, STYLE, SIZE, OR COLOR.

FOR PROVIDING A SOCIAL NETWORKING WEBSITE FOR ENTERTAINMENT PURPOSES; PROVISION OF A WEB SITE FEATURING INFORMATION ON FASHION; PROVISION OF A WEB SITE FEATURING INFORMATION ON LIFESTYLES (U.S. CLS. 100 AND 101).

FIRST USE 10-13-2003; IN COMMERCE 10-15-2003.  
BRENDAN REGAN, EXAMINING ATTORNEY

---

SN 85-178,531. PERRY STREET SOFTWARE, INC., NEW YORK, NY. FILED 11-17-2010.

# Scruff

THE MARK CONSISTS OF STANDARD CHARACTERS WITHOUT CLAIM TO ANY PARTICULAR FONT, STYLE, SIZE, OR COLOR.

FOR DATING SERVICES, NAMELY, PROVIDING AN ON-LINE COMPUTER DATABASE FEATURING SINGLE PEOPLE INTERESTED IN MEETING OTHER SINGLE PEOPLE; INTERNET BASED SOCIAL NETWORKING, INTRODUCTION, AND DATING SERVICES; INTERNET-BASED DATING, SOCIAL INTRODUCTION AND SOCIAL NETWORKING SERVICES; MARRIAGE PARTNER INTRODUCTION OR DATING SERVICES; ON-LINE GAY, LESBIAN AND BISEXUAL SOCIAL NETWORKING SERVICES; PROVIDING AN ON-LINE SEARCHABLE DATABASE FEATURING INFORMATION CONCERNING THE LIFESTYLES OF GAY, LESBIAN, BI-SEXUAL AND TRANSGENDER PEOPLE (U.S. CLS. 100 AND 101).

FIRST USE 7-24-2010; IN COMMERCE 7-24-2010.  
BRENDAN REGAN, EXAMINING ATTORNEY

---

SN 85-178,985. FIND YOUR FACE MATE, LLC, NEW YORK, NY. FILED 11-17-2010.

# Find Your Face Mate

THE MARK CONSISTS OF STANDARD CHARACTERS WITHOUT CLAIM TO ANY PARTICULAR FONT, STYLE, SIZE, OR COLOR.

FOR ON-LINE INTERNET DATING SERVICE (U.S. CLS. 100 AND 101).  
MARK SPARACINO, EXAMINING ATTORNEY

**CLASS 45—(Continued).**

SN 85-179,182. KLISANIN, DANA, NEW YORK, NY. FILED 11-17-2010.

# Hero-Link

THE MARK CONSISTS OF STANDARD CHARACTERS WITHOUT CLAIM TO ANY PARTICULAR FONT, STYLE, SIZE, OR COLOR.

FOR PROVIDING A SOCIAL NETWORKING WEBSITE AT WHICH A USER CAN GIVE CHARITABLE GIFTS TO OTHERS; PROVIDING A SOCIAL NETWORKING WEBSITE FOR ENTERTAINMENT PURPOSES (U.S. CLS. 100 AND 101).

FIRST USE 3-1-2010; IN COMMERCE 11-1-2010.  
CAROLINE WOOD, EXAMINING ATTORNEY

**CLASS 45—(Continued).**

SN 85-179,958. DIVORCE2DATING.COM, NORTH OLMSTED, OH. FILED 11-18-2010.



THE MARK CONSISTS OF THE STYLIZED TEXT "DIVORCE2DATING".

FOR INTERNET-BASED DATING, SOCIAL INTRODUCTION AND SOCIAL NETWORKING SERVICES (U.S. CLS. 100 AND 101).

FIRST USE 3-1-2008; IN COMMERCE 3-1-2008.  
TEJBIR SINGH, EXAMINING ATTORNEY

SN 85-179,549. MCGRATH, JOSEPH, RICHMOND, VA. FILED 11-18-2010.

## YOUR LICENSE IS YOUR LIFE

THE MARK CONSISTS OF STANDARD CHARACTERS WITHOUT CLAIM TO ANY PARTICULAR FONT, STYLE, SIZE, OR COLOR.

FOR ATTORNEY SERVICES (U.S. CLS. 100 AND 101).  
FIRST USE 9-25-1997; IN COMMERCE 9-25-1997.  
ANN E. SAPPENFIELD, EXAMINING ATTORNEY

SN 85-190,654. FACEBARKK, POUND RIDGE, NY. FILED 12-3-2010.

## Networking For Dogs

THE MARK CONSISTS OF STANDARD CHARACTERS WITHOUT CLAIM TO ANY PARTICULAR FONT, STYLE, SIZE, OR COLOR.

NO CLAIM IS MADE TO THE EXCLUSIVE RIGHT TO USE "NETWORKING", APART FROM THE MARK AS SHOWN.

FOR ON-LINE SOCIAL NETWORKING SERVICES (U.S. CLS. 100 AND 101).  
WENDY JUN, EXAMINING ATTORNEY

SN 85-179,772. LAW OFFICES OF STEPHEN C. BROWN & ASSOCIATES, ROCHESTER, NH. FILED 11-18-2010.



THE MARK CONSISTS OF A GRAPHICAL DEPICTION OF A COLUMN AND THE LETTER "B" INSIDE THE UPPER PORTION OF THE COLUMN.

FOR LEGAL SERVICES (U.S. CLS. 100 AND 101).  
FIRST USE 11-29-2008; IN COMMERCE 1-30-2009.  
MARK PILARO, EXAMINING ATTORNEY

SN 85-193,885. CROWDSOURCING INTERNATIONAL, DALLAS, TX. FILED 12-9-2010.



NO CLAIM IS MADE TO THE EXCLUSIVE RIGHT TO USE "SOCIAL SAFETY SYSTEM", APART FROM THE MARK AS SHOWN.

THE COLOR(S) BLUE, LIME GREEN, AND LIGHT BLUE IS/ARE CLAIMED AS A FEATURE OF THE MARK.

THE MARK CONSISTS OF THE WORDING "CSI459KID SOCIAL NETWORKING SYSTEM". THE LOWER CASE LETTERS CSI IN BLUE UNDERNEATH THE NUMBER "4", WHICH IS LIME GREEN IN COLOR; THE NUMBERS "5"; "9" IN THE COLOR OF LIME GREEN FOLLOW THE NUMBER "4"; THE LOWER CASE LETTER "K" IN THE COLOR BLUE IMMEDIATELY FOLLOWS THE NUMBER "9"; THE SILHOUETTE OF A MAN IN THE COLOR BLUE WITH HIS HEAD TILTED DOWN TOWARD THE RIGHT, WITH HIS LEFT HAND IN HIS POCKET AND HIS RIGHT

**CLASS 45—(Continued).**

HAND DIALING A CELL PHONE WITH A BLUE SPEECH BALLOON ABOVE HIS HEAD WITH THE NUMBERS "4","5","9" IN WHITE REFLECTING HIM DIALING THOSE NUMBERS ON HIS CELL PHONE FOLLOW THE LETTER "K"; THE LOWER CASE LETTER "D" IN BLUE FOLLOWS THE SILHOUETTE OF THE MAN; THE WORDS "SOCIAL SAFETY SYSTEM" ARE IN LOWER CASE LETTERS IN THE COLOR LIGHT BLUE AND ARE SHOWN BENEATH THE ABOVE DESIGN, BEGINNING UNDER THE NUMBER "9" AND ENDING UNDER THE LETTER "D".

FOR SECURITY SERVICES, NAMELY, MONITORING CHILDREN'S INTERNET AND CELL PHONE USAGE, ENABLING PARENTS TO HELP PROTECT THEIR CHILDREN FROM CYBER BULLIES AND PREDATORS AND TO LOCATE THEIR CHILDREN FROM ANY COMPUTER AS A MEANS OF KEEPING THE FAMILY'S INFORMATION SECURE AND PRIVATE (U.S. CLS. 100 AND 101).

FIRST USE 11-1-2010; IN COMMERCE 11-1-2010.

ARETHA SOMERVILLE, EXAMINING ATTORNEY

\* \* \* \* \*

SECTION 3.—PRIOR UNITED STATES CLASSIFICATION

APPLICATION IN MORE THAN ONE CLASS

SN 85-066,401. PICKED RIGHT HOLDINGS, LP, DALLAS, TX. FILED 6-18-2010.



NO CLAIM IS MADE TO THE EXCLUSIVE RIGHT TO USE "PICKED" AND ".COM", APART FROM THE MARK AS SHOWN.

THE COLOR(S) BLACK, WHITE, RED, GREEN, AND BROWN IS/ARE CLAIMED AS A FEATURE OF THE MARK.

THE MARK CONSISTS OF A RED APPLE HAVING A BROWN STEM WITH A GREEN LEAF ATTACHED, SAID APPLE HAVING A WHITE HAND OUTLINED IN BLACK MAKING AN OKAY SYMBOL SUPERIMPOSED UPON THE APPLE IN THE FOREGROUND OF THE GRAPHIC; LITERAL ELEMENT "PICKED RIGHT" IN RED AND ".COM" IN BLACK APPEARS BENEATH THE APPLE AND HAND.

THE CERTIFICATION MARK, AS INTENDED TO BE USED BY AUTHORIZED PERSONS, IS INTENDED TO CERTIFY THAT THE GOODS AND SERVICES EMANATE FROM PROVIDERS THAT EMPLOY INDIVIDUALS MEETING OR EXCEEDING UNITED STATES GOVERNMENT STANDARDS FOR LEGAL EMPLOYMENT STATUS AND WORK AUTHORIZATION.

**CLASS A—GOODS**

FOR FOOD AND AGRICULTURAL COMMODITIES.  
CLASS B—SERVICES

FOR RETAIL, DISTRIBUTION, HARVESTING, WHOLESALE, PURCHASING, STAFFING, GROWING, PLANTING, CULTIVATION, AND PROCESSING SERVICES IN THE FIELD OF FOOD AND AGRICULTURAL COMMODITIES.

BRIAN CALLAGHAN, EXAMINING ATTORNEY

\* \* \* \* \*

SECTION 4.—PRIOR UNITED STATES CLASSIFICATION

APPLICATION IN ONE CLASS

COLLECTIVE MEMBERSHIP MARKS

CLASS 200—COLLECTIVE MEMBERSHIP  
SN 77-816,659. AMERICAN COLLEGE OF OCCUPATIONAL  
AND ENVIRONMENTAL MEDICINE, ELK GROVE  
VILLAGE, IL. FILED 8-31-2009.

SN 85-179,790. NATIONAL ASSOCIATION OF PUBLIC  
INSURANCE ADJUSTERS, POTOMAC FALLS, VA.  
FILED 11-18-2010.



SPPA

THE MARK CONSISTS OF STANDARD CHARACTERS  
WITHOUT CLAIM TO ANY PARTICULAR FONT, STYLE,  
SIZE, OR COLOR.  
FOR INDICATING MEMBERSHIP IN AN ORGANIZA-  
TION OF PUBLIC INSURANCE ADJUSTERS.  
FIRST USE 12-7-1986; IN COMMERCE 12-7-1986.  
LINDA MICKLEBURGH, EXAMINING ATTORNEY

OWNER OF U.S. REG. NOS. 1,824,672 AND 1,824,726.  
NO CLAIM IS MADE TO THE EXCLUSIVE RIGHT TO  
USE "1916", APART FROM THE MARK AS SHOWN.  
SEC. 2(F) AS TO "AMERICAN COLLEGE OF OCCUPA-  
TIONAL AND ENVIRONMENTAL MEDICINE".  
FOR INDICATING MEMBERSHIP IN AN ORGANIZA-  
TION FOR PROFESSIONALS IN THE FIELD OF OCCU-  
PATIONAL AND ENVIRONMENTAL MEDICINE.  
FIRST USE 12-0-1992; IN COMMERCE 12-0-1992.  
SAIMA MAKHDOOM, EXAMINING ATTORNEY

SN 85-179,836. NATIONAL ASSOCIATION OF PUBLIC  
INSURANCE ADJUSTERS, POTOMAC FALLS, VA.  
FILED 11-18-2010.

SN 85-179,757. NATIONAL ASSOCIATION OF PUBLIC  
INSURANCE ADJUSTERS, POTOMAC FALLS, VA.  
FILED 11-18-2010.

PPA

CPPA

THE MARK CONSISTS OF STANDARD CHARACTERS  
WITHOUT CLAIM TO ANY PARTICULAR FONT, STYLE,  
SIZE, OR COLOR.  
FOR INDICATING MEMBERSHIP IN AN ORGANIZA-  
TION OF PUBLIC INSURANCE ADJUSTERS.  
LINDA MICKLEBURGH, EXAMINING ATTORNEY

THE MARK CONSISTS OF STANDARD CHARACTERS  
WITHOUT CLAIM TO ANY PARTICULAR FONT, STYLE,  
SIZE, OR COLOR.  
FOR INDICATING MEMBERSHIP IN AN ORGANIZA-  
TION OF PUBLIC INSURANCE ADJUSTERS.  
FIRST USE 12-7-1986; IN COMMERCE 12-7-1986.  
LINDA MICKLEBURGH, EXAMINING ATTORNEY

CERTIFICATION MARKS

CLASS B—SERVICES

SN 85-180,338. AMERICAN NATIONAL STANDARDS  
INSTITUTE, INCORPORATED, NEW YORK, NY.  
FILED 11-18-2010.

THE CERTIFICATION MARK, AS INTENDED TO BE  
USED BY AUTHORIZED PERSONS, IS INTENDED TO  
CERTIFY THAT ACCREDITED CERTIFICATE ISSUERS  
HAVE MET A SET OF DEVELOPED STANDARDS OF  
GOOD PRACTICES FOR EDUCATION AND TRAINING  
CERTIFICATE PROGRAMS.

FOR EDUCATION AND TRAINING .  
MICHAEL KEATING, EXAMINING ATTORNEY

**ANSI-CAP**

THE MARK CONSISTS OF STANDARD CHARACTERS  
WITHOUT CLAIM TO ANY PARTICULAR FONT, STYLE,  
SIZE, OR COLOR.

\* \* \* \* \*



# TRADEMARK REGISTRATIONS ISSUED

## PRINCIPAL REGISTER

### SECTION 1.— INTERNATIONAL CLASSIFICATION

The short titles associated below with the international class numbers are terms designed merely for quick identification and are not an official part of the international classification. The full names of international classes are given in section 6.1 of the trademark rules of practice.

The designation "U.S. Cl." appearing in this section refers to the U.S. class in effect prior to Sep. 1, 1973 rather than the international class which applies to applications filed on or after that date. For adoption of international classification see notice in the OFFICIAL GAZETTE of Jun. 26, 1973 (911 O.G. TM 210).

#### CLASS 1—CHEMICALS

- 3,939,470. **EARTHOIL (STANDARD CHARACTER)**. TREATT PLC, MULTIPLE CLASS, (INT. CLS. 1 AND 3), (U.S. CLS. 1, 4, 5, 6, 10, 26, 46, 50, 51 AND 52). SN 77-726,147. PUB. 1-18-2011. FILED 4-30-2009.
- 3,939,471. **EARTHOIL AND DESIGN**. TREATT PLC, MULTIPLE CLASS, (INT. CLS. 1 AND 3), (U.S. CLS. 1, 4, 5, 6, 10, 26, 46, 50, 51 AND 52). SN 77-726,199. PUB. 1-18-2011. FILED 4-30-2009.
- 3,939,472. **CIVITAS (STANDARD CHARACTER)**. SUNCOR ENERGY INC., MULTIPLE CLASS, (INT. CLS. 1 AND 5), (U.S. CLS. 1, 5, 6, 10, 18, 26, 44, 46, 51 AND 52). SN 77-726,218. PUB. 1-18-2011. FILED 4-30-2009.
- 3,939,473. **CIVITAS AND DESIGN**. SUNCOR ENERGY INC., MULTIPLE CLASS, (INT. CLS. 1 AND 5), (U.S. CLS. 1, 5, 6, 10, 18, 26, 44, 46, 51 AND 52). SN 77-726,275. PUB. 1-18-2011. FILED 4-30-2009.
- 3,939,532. **XYPEX CONCRETE WATERPROOFING BY CRYSTALLIZATION (STANDARD CHARACTER)**. XYPEX CHEMICAL CORPORATION, MULTIPLE CLASS, (INT. CLS. 1 AND 37), (U.S. CLS. 1, 5, 6, 10, 26, 46, 100, 103 AND 106). SN 77-810,272. PUB. 1-18-2011. FILED 8-21-2009.
- 3,939,600. **LACTOYIELD (STANDARD CHARACTER)**. CHR. HANSEN A/S, (U.S. CLS. 1, 5, 6, 10, 26 AND 46). SN 77-889,446. PUB. 1-18-2011. FILED 12-9-2009.
- 3,939,670. **RHIZOPLEX (STANDARD CHARACTER)**. NOVZYMES A/S, (U.S. CLS. 1, 5, 6, 10, 26 AND 46). SN 77-925,519. PUB. 1-18-2011. FILED 2-2-2010.
- 3,939,671. **CEREGEL (STANDARD CHARACTER)**. CEREA-LUS HOLDINGS LLC, (U.S. CLS. 1, 5, 6, 10, 26 AND 46). SN 77-925,838. PUB. 1-18-2011. FILED 2-2-2010.
- 3,939,678. **OMNISPERSE (STANDARD CHARACTER)**. KEMIRA CHEMICALS, INC., (U.S. CLS. 1, 5, 6, 10, 26 AND 46). SN 77-928,776. PUB. 1-18-2011. FILED 2-5-2010.
- 3,939,755. **PRIMESTORE (STANDARD CHARACTER)**. LONGHORN VACCINES AND DIAGNOSTICS, LLC, MULTIPLE CLASS, (INT. CLS. 1 AND 5), (U.S. CLS. 1, 5, 6, 10, 18, 26, 44, 46, 51 AND 52). SN 77-940,211. PUB. 1-18-2011. FILED 2-19-2010.
- 3,939,760. **THYON (STANDARD CHARACTER)**. DIRANSA SAN LUIS, S.A., MULTIPLE CLASS, (INT. CLS. 1 AND 2), (U.S. CLS. 1, 5, 6, 10, 11, 16, 26 AND 46). SN 77-942,172. PUB. 1-18-2011. FILED 2-23-2010.
- 3,939,881. **ARTELIS (STANDARD CHARACTER)**. ARTELIS, SOCIÉTÉ ANONYME, MULTIPLE CLASS, (INT. CLS. 1, 5, 7, 9, 10 AND 42), (U.S. CLS. 1, 5, 6, 10, 13, 18, 19, 21, 23, 26, 31, 34, 35, 36, 38, 39, 44, 46, 51, 52, 100 AND 101). SN 79-044,553. PUB. 1-18-2011. FILED 5-23-2007.
- 3,939,887. **UDIAMOND AND DESIGN**. CARBODEON LTD OY, MULTIPLE CLASS, (INT. CLS. 1 AND 4), (U.S. CLS. 1, 5, 6, 10, 15, 26 AND 46). SN 79-064,347. PUB. 1-18-2011. FILED 8-5-2008.
- 3,939,933. **SILICON FIRE (STANDARD CHARACTER)**. SILICON FIRE AG, MULTIPLE CLASS, (INT. CLS. 1, 4, 7, 9 AND 12), (U.S. CLS. 1, 5, 6, 10, 13, 15, 19, 21, 23, 26, 31, 34, 35, 36, 38, 44 AND 46). SN 79-077,413. PUB. 1-18-2011. FILED 8-17-2009.
- 3,939,943. **ISPRAV (STANDARD CHARACTER)**. J. WAGNER GMBH, MULTIPLE CLASS, (INT. CLS. 1, 2 AND 7), (U.S. CLS. 1, 5, 6, 10, 11, 13, 16, 19, 21, 23, 26, 31, 34, 35 AND 46). SN 79-079,166. PUB. 1-18-2011. FILED 2-2-2010.
- 3,939,977. **BIP (STYLIZED)**. BIP GMBH, MULTIPLE CLASS, (INT. CLS. 1, 17 AND 19), (U.S. CLS. 1, 5, 6, 10, 12, 13, 26, 33, 35, 46 AND 50). SN 79-080,853. PUB. 1-18-2011. FILED 2-11-2010.
- 3,939,980. **ECTYCELL (STANDARD CHARACTER)**. CELLECTIS, MULTIPLE CLASS, (INT. CLS. 1, 5, 9, 42 AND 45), (U.S. CLS. 1, 5, 6, 10, 18, 21, 23, 26, 36, 38, 44, 46, 51, 52, 100 AND 101). SN 79-081,065. PUB. 1-18-2011. FILED 10-2-2009.
- 3,939,981. **BRENNTAG (STANDARD CHARACTER)**. BRENNTAG HOLDING GMBH, MULTIPLE CLASS, (INT. CLS. 1, 2, 3, 4, 37, 39, 40 AND 42), (U.S. CLS. 1, 4, 5, 6, 10, 11, 15, 16, 26, 46, 50, 51, 52, 100, 101, 103, 105 AND 106). SN 79-081,068. PUB. 1-18-2011. FILED 9-11-2009.
- 3,940,009. **NIKWAX (STANDARD CHARACTER)**. NICHOLAS BROWN, MULTIPLE CLASS, (INT. CLS. 1, 3, 24 AND 25), (U.S. CLS. 1, 4, 5, 6, 10, 22, 26, 39, 42, 46, 50, 51 AND 52). SN 79-082,475. PUB. 1-18-2011. FILED 4-27-2010.
- 3,940,016. **ACTISAN (STANDARD CHARACTER)**. COMPAGNIE FINANCIERE ET DE PARTICIPATIONS ROULLIER, MULTIPLE CLASS, (INT. CLS. 1 AND 5), (U.S. CLS. 1, 5, 6, 10, 18, 26, 44, 46, 51 AND 52). SN 79-082,884. PUB. 1-18-2011. FILED 12-18-2009.
- 3,940,022. **STEAMIC (STANDARD CHARACTER)**. TALC DE LUZENAC FRANCE, MULTIPLE CLASS, (INT. CLS. 1 AND 17), (U.S. CLS. 1, 5, 6, 10, 12, 13, 26, 35, 46 AND 50). SN 79-083,498. PUB. 1-18-2011. FILED 5-11-2010.
- 3,940,023. **PLASTO XLCARE AND DESIGN**. PLASTO, MULTIPLE CLASS, (INT. CLS. 1, 5 AND 17), (U.S. CLS. 1, 5, 6, 10, 12, 13, 18, 26, 35, 44, 46, 50, 51 AND 52). SN 79-083,582. PUB. 1-18-2011. FILED 5-28-2010.
- 3,940,032. **BARIL COATINGS BV AND DESIGN**. BARIL COATINGS B.V., MULTIPLE CLASS, (INT. CLS. 1, 2 AND 3), (U.S. CLS. 1, 4, 5, 6, 10, 11, 16, 26, 46, 50, 51 AND 52). SN 79-084,480. PUB. 1-18-2011. FILED 5-21-2010.
- 3,940,038. **SIKA (STYLIZED)**. SIKA AG, MULTIPLE CLASS, (INT. CLS. 1, 2, 17, 19 AND 27), (U.S. CLS. 1, 5, 6, 10, 11, 12, 13, 16, 19, 20, 26, 33, 35, 37, 42, 46 AND 50). SN 79-084,885. PUB. 1-18-2011. FILED 6-15-2010.
- 3,940,069. **SELTIMA (STANDARD CHARACTER)**. BASF SE, MULTIPLE CLASS, (INT. CLS. 1 AND 5), (U.S. CLS. 1, 5, 6, 10, 18, 26, 44, 46, 51 AND 52). SN 79-087,652. PUB. 1-18-2011. FILED 8-19-2010.
- 3,940,085. **HOLDOUT (STANDARD CHARACTER)**. CEREA-LUS HOLDINGS LLC, (U.S. CLS. 1, 5, 6, 10, 26 AND 46). SN 85-003,922. PUB. 1-18-2011. FILED 4-1-2010.
- 3,940,238. **DORSENE (STANDARD CHARACTER)**. BREYNER, MULTIPLE CLASS, (INT. CLS. 1 AND 40), (U.S. CLS. 1, 5, 6, 10, 26, 46, 100, 103 AND 106). SN 85-060,729. PUB. 1-18-2011. FILED 6-11-2010.
- 3,940,240. **SELTORN (STANDARD CHARACTER)**. BREYNER, MULTIPLE CLASS, (INT. CLS. 1 AND 40), (U.S. CLS. 1, 5, 6, 10, 26, 46, 100, 103 AND 106). SN 85-060,770. PUB. 1-18-2011. FILED 6-11-2010.
- 3,940,438. **OXYTRON (STANDARD CHARACTER)**. BLASCH PRECISION CERAMICS, INC., (U.S. CLS. 1, 5, 6, 10, 26 AND 46). SN 85-096,570. PUB. 1-18-2011. FILED 7-30-2010.
- 3,940,480. **UCC AND DESIGN**. URANUS CHEMICALS CO.,

LTD., (U.S. CLS. 1, 5, 6, 10, 26 AND 46). SN 85-097,490. PUB. 1-18-2011. FILED 7-31-2010.  
 3,940,925. **ENVIROHOLD AND DESIGN**. ENVIROHOLD, INC. (U.S. CLS. 1, 5, 6, 10, 26 AND 46). SN 85-121,752. PUB. 1-18-2011. FILED 9-2-2010.  
 3,940,962. **VIKOLOX (STANDARD CHARACTER)**. ARKEMA INC., (U.S. CLS. 1, 5, 6, 10, 26 AND 46). SN 85-146,193. PUB. 1-18-2011. FILED 10-6-2010.

---

## CLASS 2—PAINTS

3,939,760 ( *See Class 1 for this trademark*).  
 3,939,848. **POWER OF COLOR (STANDARD CHARACTER)**. ECOSERVICES GROUP, (U.S. CLS. 6, 11 AND 16). SN 77-965,753. PUB. 1-18-2011. FILED 3-23-2010.  
 3,939,855. **KEL-BOND ADHESION PLUS (STANDARD CHARACTER)**. KELLY-MOORE PAINT COMPANY, INC., (U.S. CLS. 6, 11 AND 16). SN 77-967,666. PUB. 1-18-2011. FILED 3-24-2010.  
 3,939,942. **MISCELLANEOUS DESIGN**. APEX MICROELECTRONICS COMPANY; LIMITED, MULTIPLE CLASS, (INT. CLS. 2 AND 9), (U.S. CLS. 6, 11, 16, 21, 23, 26, 36 AND 38). SN 79-078,956. PUB. 1-18-2011. FILED 11-23-2009.  
 3,939,943 ( *See Class 1 for this trademark*).  
 3,939,981 ( *See Class 1 for this trademark*).  
 3,940,032 ( *See Class 1 for this trademark*).  
 3,940,038 ( *See Class 1 for this trademark*).

---

## CLASS 3—COSMETICS AND CLEANING PREPARATIONS

3,939,349. **MINIPOPS (STANDARD CHARACTER)**. K-TEL INTERNATIONAL LTD., MULTIPLE CLASS, (INT. CLS. 3, 9, 16, 28 AND 41), (U.S. CLS. 1, 2, 4, 5, 6, 21, 22, 23, 26, 29, 36, 37, 38, 50, 51, 52, 100, 101 AND 107). SN 76-611,081. PUB. 3-10-2009. FILED 9-13-2004.  
 3,939,371. **NEVER DRY AND DESIGN**. WEIMAN PRODUCTS, LLC, MULTIPLE CLASS, (INT. CLS. 3 AND 5), (U.S. CLS. 1, 4, 6, 18, 44, 46, 50, 51 AND 52). SN 76-702,388. PUB. 1-18-2011. FILED 4-7-2010.  
 3,939,423. **ESTURA (STANDARD CHARACTER)**. PACIFIC-PHARMA CORPORATION, (U.S. CLS. 1, 4, 6, 50, 51 AND 52). SN 77-473,718. PUB. 1-18-2011. FILED 5-13-2008.  
 3,939,461. **TAKASHI TOKYO (STYLIZED)**. TAKASHI COSMETICS (THAILAND) CO., LTD., MULTIPLE CLASS, (INT. CLS. 3, 16, 41 AND 44), (U.S. CLS. 1, 2, 4, 5, 6, 22, 23, 29, 37, 38, 50, 51, 52, 100, 101 AND 107). SN 77-693,553. PUB. 1-18-2011. FILED 3-18-2009.  
 3,939,470 ( *See Class 1 for this trademark*).  
 3,939,471 ( *See Class 1 for this trademark*).  
 3,939,493. **INTENSE (STANDARD CHARACTER)**. JOHNSON & JOHNSON, (U.S. CLS. 1, 4, 6, 50, 51 AND 52). SN 77-766,134. PUB. 11-24-2009. FILED 6-23-2009.  
 3,939,587. **FORHANS (STANDARD CHARACTER)**. DR. FRESH, INC., (U.S. CLS. 1, 4, 6, 50, 51 AND 52). SN 77-873,661. PUB. 1-18-2011. FILED 11-16-2009.  
 3,939,607. **WATERPROOF AND DESIGN**. TEND SKIN INTERNATIONAL, INC., (U.S. CLS. 1, 4, 6, 50, 51 AND 52). SN 77-899,198. PUB. 1-18-2011. FILED 12-22-2009.  
 3,939,616. **FB AND DESIGN**. HAPPY JUNK LLC, (U.S. CLS. 1, 4, 6, 50, 51 AND 52). SN 77-902,201. PUB. 10-12-2010. FILED 12-29-2009.  
 3,939,629. **BUCK & FILLY AND DESIGN**. BUCK AND FILLY LIMITED, MULTIPLE CLASS, (INT. CLS. 3, 9, 18, 21, 25 AND 35), (U.S. CLS. 1, 2, 3, 4, 6, 13, 21, 22, 23, 26, 29, 30, 33, 36, 38, 39, 40, 41, 50, 51, 52, 100, 101 AND 102). SN 77-914,787. PUB. 1-18-2011. FILED 1-19-2010.  
 3,939,632. **ORIBE (STANDARD CHARACTER)**. ORIBE HAIR CARE, LLC, MULTIPLE CLASS, (INT. CLS. 3 AND 35), (U.S. CLS. 1, 4, 6, 50, 51, 52, 100, 101 AND 102). SN 77-915,487. PUB. 1-18-2011. FILED 1-20-2010.  
 3,939,640. **YAGOLICIOUS AND DESIGN**. YAGO M. JONES, AKA YAGO M. JONES, (U.S. CLS. 1, 4, 6, 50, 51 AND 52).

SN 77-918,717. PUB. 1-18-2011. FILED 1-23-2010.  
 3,939,674. **GEORGIE BEAUTY (STANDARD CHARACTER)**. GEORGIE BEAUTY, LLC, (U.S. CLS. 1, 4, 6, 50, 51 AND 52). SN 77-928,021. PUB. 1-18-2011. FILED 2-4-2010.  
 3,939,709. **EVANHEALY (STANDARD CHARACTER)**. PLANT DEVAS, INC., (U.S. CLS. 1, 4, 6, 50, 51 AND 52). SN 77-934,628. PUB. 1-18-2011. FILED 2-12-2010.  
 3,939,794. **LES THERMALIENNES (STANDARD CHARACTER)**. PIERRE FABRE S.A., MULTIPLE CLASS, (INT. CLS. 3 AND 5), (U.S. CLS. 1, 4, 6, 18, 44, 46, 50, 51 AND 52). SN 77-952,112. PUB. 1-18-2011. FILED 3-5-2010.  
 3,939,799. **MASTER OF DISGUISE (STANDARD CHARACTER)**. FORSYTHE COSMETIC GROUP, LTD., (U.S. CLS. 1, 4, 6, 50, 51 AND 52). SN 77-953,364. PUB. 1-18-2011. FILED 3-8-2010.  
 3,939,809. **DENSI-RECHARGE (STANDARD CHARACTER)**. L'OREAL, MULTIPLE CLASS, (INT. CLS. 3 AND 5), (U.S. CLS. 1, 4, 6, 18, 44, 46, 50, 51 AND 52). SN 77-956,258. PUB. 1-18-2011. FILED 3-11-2010.  
 3,939,829. **CORRECTION FLUID (STANDARD CHARACTER)**. BIOPELLE, INC., (U.S. CLS. 1, 4, 6, 50, 51 AND 52). SN 77-962,204. PUB. 1-18-2011. FILED 3-18-2010.  
 3,939,876. **HAYASHI (STANDARD CHARACTER)**. HAYASHI WORLDWIDE LLC, (U.S. CLS. 1, 4, 6, 50, 51 AND 52). SN 78-925,500. PUB. 1-18-2011. FILED 7-10-2006.  
 3,939,878. **EXUBERANCE (STANDARD CHARACTER)**. EXUBERANCE INTERNATIONAL INC., (U.S. CLS. 1, 4, 6, 50, 51 AND 52). SN 78-968,717. PUB. 1-18-2011. FILED 9-7-2006.  
 3,939,913. **THE ROYAL OPERA HOUSE (STANDARD CHARACTER)**. ROYAL OPERA HOUSE COVENT GARDEN; LIMITED, MULTIPLE CLASS, (INT. CLS. 3, 9, 16, 18, 21, 25, 30, 38 AND 41), (U.S. CLS. 1, 2, 3, 4, 5, 6, 13, 21, 22, 23, 26, 29, 30, 33, 36, 37, 38, 39, 40, 41, 46, 50, 51, 52, 100, 101, 104 AND 107). SN 79-074,333. PUB. 1-18-2011. FILED 7-24-2009.  
 3,939,936. **O'NEILL (STANDARD CHARACTER)**. SISCO TEXTILES N.V., MULTIPLE CLASS, (INT. CLS. 3, 9, 14, 16, 18, 25, 28 AND 35), (U.S. CLS. 1, 2, 3, 4, 5, 6, 21, 22, 23, 26, 27, 28, 29, 36, 37, 38, 39, 41, 50, 51, 52, 100, 101 AND 102). SN 79-077,763. PUB. 1-18-2011. FILED 12-11-2009.  
 3,939,962. **STIMULSKIN PLUS LIFT RENEWAL SERIES (STANDARD CHARACTER)**. LABORATOIRES D'ARPHIN, (U.S. CLS. 1, 4, 6, 50, 51 AND 52). SN 79-080,433. PUB. 1-18-2011. FILED 2-2-2010.  
 3,939,981 ( *See Class 1 for this trademark*).  
 3,940,000. **STIGG (STANDARD CHARACTER)**. E.V.I. COSMETICS GMBH, MULTIPLE CLASS, (INT. CLS. 3, 5 AND 21), (U.S. CLS. 1, 2, 4, 6, 13, 18, 23, 29, 30, 33, 40, 44, 46, 50, 51 AND 52). SN 79-081,829. PUB. 1-18-2011. FILED 11-3-2009.  
 3,940,009 ( *See Class 1 for this trademark*).  
 3,940,029. **FEIYUE (STYLIZED)**. FEIYUE HOLDING PTE LTD, MULTIPLE CLASS, (INT. CLS. 3, 9, 14, 16, 18, 24, 25, 26, 28 AND 35), (U.S. CLS. 1, 2, 3, 4, 5, 6, 21, 22, 23, 26, 27, 28, 29, 36, 37, 38, 39, 40, 41, 42, 50, 51, 52, 100, 101 AND 102). SN 79-084,130. PUB. 1-18-2011. FILED 4-22-2010.  
 3,940,032 ( *See Class 1 for this trademark*).  
 3,940,040. **MISCELLANEOUS DESIGN**. TEOBRAS S.R.L., MULTIPLE CLASS, (INT. CLS. 3, 9 AND 25), (U.S. CLS. 1, 4, 6, 21, 22, 23, 26, 36, 38, 39, 50, 51 AND 52). SN 79-084,965. PUB. 1-18-2011. FILED 4-16-2010.  
 3,940,042. **DAVID MALLETT (STANDARD CHARACTER)**. DAVID MALLETT GROUP SARL, MULTIPLE CLASS, (INT. CLS. 3, 4, 21 AND 44), (U.S. CLS. 1, 2, 4, 6, 13, 15, 23, 29, 30, 33, 40, 50, 51, 52, 100 AND 101). SN 79-085,003. PUB. 1-18-2011. FILED 3-5-2010.  
 3,940,050. **NEW LOOK 1947 (STANDARD CHARACTER)**. PARFUMS CHRISTIAN DIOR DIRECTION JURIDIQUE, (U.S. CLS. 1, 4, 6, 50, 51 AND 52). SN 79-085,506. PUB. 1-18-2011. FILED 7-7-2010.  
 3,940,063. **HEARTBEAT (STANDARD CHARACTER)**. COTY GERMANY GMBH, (U.S. CLS. 1, 4, 6, 50, 51 AND 52). SN 79-087,029. PUB. 1-18-2011. FILED 8-19-2010.  
 3,940,072. **THERMAL IMAGE (STANDARD CHARACTER)**. WELLA AKTIENGESELLSCHAFT, (U.S. CLS. 1, 4, 6, 50, 51 AND 52). SN 79-088,081. PUB. 1-18-2011. FILED 7-6-2010.  
 3,940,073. **CREATE CHARACTER (STANDARD CHARACTER)**. WELLA AKTIENGESELLSCHAFT, (U.S. CLS. 1, 4, 6, 50, 51 AND 52). SN 79-088,117. PUB. 1-18-2011. FILED 8-5-2010.

3,940,074. **DISTINCT DESIGN (STANDARD CHARACTER)**. WELLA AKTIENGESELLSCHAFT, (U.S. CLS. 1, 4, 6, 50, 51 AND 52). SN 79-088,152. PUB. 1-18-2011. FILED 7-6-2010.

3,940,075. **BASECUT (STANDARD CHARACTER)**. KWH MIRKA LTD., (U.S. CLS. 1, 4, 6, 50, 51 AND 52). SN 79-088,861. PUB. 1-18-2011. FILED 7-27-2010.

3,940,102. **MATTE-IFIED AND DESIGN**. FORSYTHE COSMETIC GROUP, LTD., (U.S. CLS. 1, 4, 6, 50, 51 AND 52). SN 85-013,295. PUB. 1-18-2011. FILED 4-13-2010.

3,940,163. **FOCA PHOSPHATE-FREE LIQUID DETERGENT FOR CLOTHES AND DESIGN**. FABRICA DE JABON LA CORONA, S.A. DE C.V., (U.S. CLS. 1, 4, 6, 50, 51 AND 52). SN 85-038,072. PUB. 1-18-2011. FILED 5-13-2010.

3,940,179. **ANTHESIS ORGANIC SKINCARE LET YOUR SKIN BLOSSOM AND DESIGN**. ANTHESIS ORGANIC SKINCARE INC., (U.S. CLS. 1, 4, 6, 50, 51 AND 52). SN 85-042,068. PUB. 1-18-2011. FILED 5-18-2010.

3,940,213. **YOUTHOLGY RESEARCH INSTITUTE (STANDARD CHARACTER)**. YOUTHOLGY RESEARCH INSTITUTE, LLC, MULTIPLE CLASS, (INT. CLS. 3 AND 35), (U.S. CLS. 1, 4, 6, 50, 51, 52, 100, 101 AND 102). SN 85-053,088. PUB. 1-18-2011. FILED 6-2-2010.

3,940,269. **THE SCIENCE OF LOOKING AWESOME (STANDARD CHARACTER)**. RECKITT & COLMAN (OVERSEAS) LIMITED, MULTIPLE CLASS, (INT. CLS. 3 AND 5), (U.S. CLS. 1, 4, 6, 18, 44, 46, 50, 51 AND 52). SN 85-069,539. PUB. 1-18-2011. FILED 6-23-2010.

3,940,296. **SHEA VISION (STANDARD CHARACTER)**. DR. WOODS PRODUCTS, LLC, (U.S. CLS. 1, 4, 6, 50, 51 AND 52). SN 85-077,923. PUB. 1-18-2011. FILED 7-5-2010.

3,940,314. **PCT-COSMETICS (STANDARD CHARACTER)**. FEDERATION OF MIGROS COOPERATIVES, (U.S. CLS. 1, 4, 6, 50, 51 AND 52). SN 85-081,703. PUB. 1-18-2011. FILED 7-9-2010.

3,940,393. **THE BEAUTYWRAP AND DESIGN**. PACKET SOLUTIONS, INC., (U.S. CLS. 1, 4, 6, 50, 51 AND 52). SN 85-093,652. PUB. 1-18-2011. FILED 7-27-2010.

3,940,404. **GREEN AFRO DIVA - NATURAL LIVING WITH FLAVA (STANDARD CHARACTER)**. HARRIS, CHRISTINE, DBA GREEN AFRO DIVA - NATURAL LIVING WITH FLAVA, (U.S. CLS. 1, 4, 6, 50, 51 AND 52). SN 85-094,345. PUB. 1-18-2011. FILED 7-27-2010.

3,940,436. **PRO-PORTION (STANDARD CHARACTER)**. DSHEALTHCARE INC., (U.S. CLS. 1, 4, 6, 50, 51 AND 52). SN 85-096,548. PUB. 1-18-2011. FILED 7-30-2010.

3,940,458. **PUSSER'S (STANDARD CHARACTER)**. PUSSER'S (2001) LTD., MULTIPLE CLASS, (INT. CLS. 3 AND 14), (U.S. CLS. 1, 2, 4, 6, 27, 28, 50, 51 AND 52). SN 85-097,256. PUB. 1-18-2011. FILED 7-30-2010.

3,940,549. **ISUN ALIVE & AGELESS SKINCARE (STANDARD CHARACTER)**. ISUN VISIONS, LLC, (U.S. CLS. 1, 4, 6, 50, 51 AND 52). SN 85-098,619. PUB. 1-18-2011. FILED 8-3-2010.

3,940,558. **POETRY INTIMATE RITUAL (STANDARD CHARACTER)**. TAMMY PARKER, (U.S. CLS. 1, 4, 6, 50, 51 AND 52). SN 85-098,694. PUB. 1-18-2011. FILED 8-3-2010.

3,940,579. **BE YOUTIFUL (STANDARD CHARACTER)**. ORIGINAL MOXIE, LLC, (U.S. CLS. 1, 4, 6, 50, 51 AND 52). SN 85-099,033. PUB. 1-18-2011. FILED 8-3-2010.

3,940,604. **JACK N' JILL ..... SINCE 1949 AND DESIGN**. BERNHAUT, JUSTIN M, TA JACKANDJILLKIDS.COM, (U.S. CLS. 1, 4, 6, 50, 51 AND 52). SN 85-099,580. PUB. 1-18-2011. FILED 8-4-2010.

3,940,640. **HAWAIIAN JUNGLE SHIELD (STANDARD CHARACTER)**. 2SN LLC, (U.S. CLS. 1, 4, 6, 50, 51 AND 52). SN 85-100,054. PUB. 1-18-2011. FILED 8-4-2010.

3,940,675. **SHOPGIRL (STANDARD CHARACTER)**. SHOP COLETTE LTD., (U.S. CLS. 1, 4, 6, 50, 51 AND 52). SN 85-100,487. PUB. 1-18-2011. FILED 8-4-2010.

3,940,700. **HAPPY ENDINGS ORGASMICALLY ORGANIC (STANDARD CHARACTER)**. HAPPY ENDINGS MASSAGE OIL, LLC, (U.S. CLS. 1, 4, 6, 50, 51 AND 52). SN 85-100,800. PUB. 1-18-2011. FILED 8-5-2010.

3,940,777. **MICHAEL MARCUS (STANDARD CHARACTER)**. MICHAEL MARCUS, DBA MICHAEL MARCUS COSMETICS, (U.S. CLS. 1, 4, 6, 50, 51 AND 52). SN 85-101,992. PUB. 1-18-2011. FILED 8-6-2010.

3,940,849. **PROCHEM (STANDARD CHARACTER)**. KARCHER NORTH AMERICA, INC., (U.S. CLS. 1, 4, 6, 50, 51 AND

52). SN 85-103,447. PUB. 1-18-2011. FILED 8-9-2010.

3,940,964. **OSTIA (STANDARD CHARACTER)**. TONY ODI-SHO EXTENSIONS, INC., (U.S. CLS. 1, 4, 6, 50, 51 AND 52). SN 85-149,086. PUB. 1-18-2011. FILED 10-9-2010.

3,940,976. **WORKING HANDS (STANDARD CHARACTER)**. THE GORILLA GLUE COMPANY, (U.S. CLS. 1, 4, 6, 50, 51 AND 52). SN 85-975,113. PUB. 10-26-2010. FILED 6-28-2010.

---

## CLASS 4—LUBRICANTS AND FUELS

3,939,562. **SOCIAL LIGHTS (STANDARD CHARACTER)**. GAINES GROUP LLC, MULTIPLE CLASS, (INT. CLS. 4, 11 AND 21), (U.S. CLS. 1, 2, 6, 13, 15, 21, 23, 29, 30, 31, 33, 34, 40 AND 50). SN 77-851,995. PUB. 3-30-2010. FILED 10-19-2009.

3,939,887 ( *See Class 1 for this trademark*).

3,939,933 ( *See Class 1 for this trademark*).

3,939,981 ( *See Class 1 for this trademark*).

3,940,042 ( *See Class 3 for this trademark*).

3,940,059. **TIGAS (STANDARD CHARACTER)**. HALDOR TOPSØE A/S, MULTIPLE CLASS, (INT. CLS. 4, 40 AND 42), (U.S. CLS. 1, 6, 15, 100, 101, 103 AND 106). SN 79-086,626. PUB. 1-18-2011. FILED 7-1-2010.

3,940,181. **WALLOVER (STANDARD CHARACTER)**. WALLOVER OIL COMPANY INCORPORATED, MULTIPLE CLASS, (INT. CLS. 4 AND 40), (U.S. CLS. 1, 6, 15, 100, 103 AND 106). SN 85-042,362. PUB. 1-18-2011. FILED 5-19-2010.

3,940,199. **WESTERN (STYLIZED)**. W W WOOD, INC., MULTIPLE CLASS, (INT. CLS. 4 AND 21), (U.S. CLS. 1, 2, 6, 13, 15, 23, 29, 30, 33, 40 AND 50). SN 85-048,377. PUB. 1-18-2011. FILED 5-26-2010.

3,940,290. **MISCELLANEOUS DESIGN**. JIANGSU EVERSO-LAR NEW ENERGY CO., LTD., (U.S. CLS. 1, 6 AND 15). SN 85-075,610. PUB. 1-18-2011. FILED 7-1-2010.

3,940,892. **FLICKERING SCENTS (STANDARD CHARACTER)**. FLICKERING SCENTS, LLC, (U.S. CLS. 1, 6 AND 15). SN 85-112,006. PUB. 1-18-2011. FILED 8-20-2010.

3,940,920. **COMPRESYN (STANDARD CHARACTER)**. JAX INC., FORMERLY BHENKE LUBRICANTS, INC., (U.S. CLS. 1, 6 AND 15). SN 85-120,567. PUB. 1-18-2011. FILED 9-1-2010.

3,940,922. **MAGNA-PLATE (STANDARD CHARACTER)**. JAX INC., FORMERLY BEHNKE LUBRICANTS, INC., (U.S. CLS. 1, 6 AND 15). SN 85-120,873. PUB. 1-18-2011. FILED 9-1-2010.

---

## CLASS 5—PHARMACEUTICALS

3,939,371 ( *See Class 3 for this trademark*).

3,939,381. **MISCELLANEOUS DESIGN**. GIL MANUFACTURING, INC., (U.S. CLS. 6, 18, 44, 46, 51 AND 52). SN 76-703,606. PUB. 1-18-2011. FILED 7-1-2010.

3,939,395. **MONSTER KHAOS ENERGY + JUICE (STANDARD CHARACTER)**. HANSEN BEVERAGE COMPANY, MULTIPLE CLASS, (INT. CLS. 5 AND 32), (U.S. CLS. 6, 18, 44, 45, 46, 48, 51 AND 52). SN 77-109,959. PUB. 1-18-2011. FILED 2-16-2007.

3,939,400. **SUPER POWER TECHNOLOGY AND DESIGN**. A & A RESEARCH AND DEVELOPMENT W.L.L. (HOLDING), MULTIPLE CLASS, (INT. CLS. 5 AND 25), (U.S. CLS. 6, 18, 22, 39, 44, 46, 51 AND 52). SN 77-233,297. PUB. 11-30-2010. FILED 7-19-2007.

3,939,401. **ANABOLIC PUMP PAK (STANDARD CHARACTER)**. A & A RESEARCH AND DEVELOPMENT W.L.L. (HOLDING), (U.S. CLS. 6, 18, 44, 46, 51 AND 52). SN 77-275,884. PUB. 11-16-2010. FILED 9-10-2007.

3,939,402. **RUSSIAN TURBO SIZE (STANDARD CHARACTER)**. A & A RESEARCH AND DEVELOPMENT W.L.L. (HOLDING), (U.S. CLS. 6, 18, 44, 46, 51 AND 52). SN 77-275,979. PUB. 1-11-2011. FILED 9-10-2007.

3,939,403. **SUPER MASS GAINER SIZE (STANDARD CHARACTER)**. A & A RESEARCH AND DEVELOPMENT W.L.L. (HOLDING), (U.S. CLS. 6, 18, 44, 46, 51 AND 52). SN 77-275,998. PUB. 1-11-2011. FILED 9-10-2007.

- 3,939,404. **TURBO PUMP (STANDARD CHARACTER)**. A & A RESEARCH AND DEVELOPMENT W.L.L. (HOLDING), (U.S. CLS. 6, 18, 44, 46, 51 AND 52). SN 77-276,023. PUB. 1-4-2011. FILED 9-10-2007.
- 3,939,419. **NANO-DIFFUSE (STANDARD CHARACTER)**. ENER US TRADEMARK LTD., DBA NANO TECHNOLOGIES, (U.S. CLS. 6, 18, 44, 46, 51 AND 52). SN 77-459,737. PUB. 1-18-2011. FILED 4-28-2008.
- 3,939,472 ( *See Class 1 for this trademark*).
- 3,939,473 ( *See Class 1 for this trademark*).
- 3,939,481. **THE CURE'S IN THE KITCHEN (STANDARD CHARACTER)**. KD DID, INC., DBA ENERGY ESSENTIALS, MULTIPLE CLASS, (INT. CLS. 5, 16, 30, 41 AND 44), (U.S. CLS. 2, 5, 6, 18, 22, 23, 29, 37, 38, 44, 46, 50, 51, 52, 100, 101 AND 107). SN 77-742,147. PUB. 1-18-2011. FILED 5-21-2009.
- 3,939,626. **PROTEKTOR (STANDARD CHARACTER)**. OMNIPHARM LIMITED, (U.S. CLS. 6, 18, 44, 46, 51 AND 52). SN 77-913,933. PUB. 1-18-2011. FILED 1-18-2010.
- 3,939,658. **DIABCELL (STANDARD CHARACTER)**. DIABCELL PTY LIMITED, (U.S. CLS. 6, 18, 44, 46, 51 AND 52). SN 77-923,011. PUB. 1-18-2011. FILED 1-28-2010.
- 3,939,755 ( *See Class 1 for this trademark*).
- 3,939,762. **PROPOL2000 (STANDARD CHARACTER)**. BEEHIVE BOTANICALS, INC., (U.S. CLS. 6, 18, 44, 46, 51 AND 52). SN 77-942,704. PUB. 1-18-2011. FILED 2-23-2010.
- 3,939,766. **BIOMAREX (STANDARD CHARACTER)**. BIOMAREX LIMITED, MULTIPLE CLASS, (INT. CLS. 5 AND 29), (U.S. CLS. 6, 18, 44, 46, 51 AND 52). SN 77-944,668. PUB. 1-18-2011. FILED 2-25-2010.
- 3,939,794 ( *See Class 3 for this trademark*).
- 3,939,800. **RICHBERRY 12000PLUS (STANDARD CHARACTER)**. INOVIOBIOLOGIC INC., (U.S. CLS. 6, 18, 44, 46, 51 AND 52). SN 77-953,445. PUB. 1-18-2011. FILED 3-8-2010.
- 3,939,809 ( *See Class 3 for this trademark*).
- 3,939,842. **BGM GALECTIN-3 (STANDARD CHARACTER)**. BG MEDICINE, INC., (U.S. CLS. 6, 18, 44, 46, 51 AND 52). SN 77-965,087. PUB. 1-18-2011. FILED 3-22-2010.
- 3,939,844. **SEQUEL (STANDARD CHARACTER)**. SEQUEL NATURALS, INC., MULTIPLE CLASS, (INT. CLS. 5 AND 32), (U.S. CLS. 6, 18, 44, 45, 46, 48, 51 AND 52). SN 77-965,100. PUB. 1-18-2011. FILED 3-22-2010.
- 3,939,846. **JEAN MICHELLE KEEP IT OFF - WEIGHT LOSS (STANDARD CHARACTER)**. JEAN MICHELLE KEEP IT OFF - WEIGHT LOSS, (U.S. CLS. 6, 18, 44, 46, 51 AND 52). SN 77-965,392. PUB. 1-18-2011. FILED 3-22-2010.
- 3,939,859. **GALECTIN-3 BGM AND DESIGN**. BG MEDICINE, INC., (U.S. CLS. 6, 18, 44, 46, 51 AND 52). SN 77-969,402. PUB. 1-18-2011. FILED 3-26-2010.
- 3,939,879. **VIBATIV (STYLIZED)**. ASTELLAS PHARMA INC., (U.S. CLS. 6, 18, 44, 46, 51 AND 52). SN 79-035,545. PUB. 6-2-2009. FILED 1-22-2007.
- 3,939,881 ( *See Class 1 for this trademark*).
- 3,939,893. **IGE AND DESIGN**. PHADIA AB, MULTIPLE CLASS, (INT. CLS. 5 AND 10), (U.S. CLS. 6, 18, 26, 39, 44, 46, 51 AND 52). SN 79-069,607. PUB. 1-18-2011. FILED 6-1-2009.
- 3,939,907. **SIMAVITA (STANDARD CHARACTER)**. FRED BERGMAN HEALTHCARE PTY LTD, MULTIPLE CLASS, (INT. CLS. 5, 9 AND 10), (U.S. CLS. 6, 18, 21, 23, 26, 36, 38, 39, 44, 46, 51 AND 52). SN 79-073,545. PUB. 1-18-2011. FILED 7-6-2009.
- 3,939,947. **ERNÄHRUNG NACH DEM COY-PRINZIP COY AND DESIGN**. JOHANNES F. COY, MULTIPLE CLASS, (INT. CLS. 5, 29, 30 AND 32), (U.S. CLS. 6, 18, 44, 45, 46, 48, 51 AND 52). SN 79-079,445. PUB. 1-18-2011. FILED 1-12-2010.
- 3,939,963. **SRPR (STANDARD CHARACTER)**. AARBAKKE MEDICAL & SCIENTIFIC AS, MULTIPLE CLASS, (INT. CLS. 5, 10 AND 44), (U.S. CLS. 6, 18, 26, 39, 44, 46, 51, 52, 100 AND 101). SN 79-080,439. PUB. 1-18-2011. FILED 12-30-2009.
- 3,939,980 ( *See Class 1 for this trademark*).
- 3,939,989. **TARGETED NUTRIENTS AND DESIGN**. TARGETED NUTRIENTS, S.L., MULTIPLE CLASS, (INT. CLS. 5, 29 AND 35), (U.S. CLS. 6, 18, 44, 46, 51, 52, 100, 101 AND 102). SN 79-081,219. PUB. 1-18-2011. FILED 1-26-2010.
- 3,940,000 ( *See Class 3 for this trademark*).
- 3,940,001. **VADEGI (STANDARD CHARACTER)**. ARES TRADING S.A., (U.S. CLS. 6, 18, 44, 46, 51 AND 52). SN 79-081,844. PUB. 1-18-2011. FILED 4-1-2010.
- 3,940,016 ( *See Class 1 for this trademark*).
- 3,940,017. **MEN FOR SAN AND DESIGN**. OSCAR MESANZA MATIA, (U.S. CLS. 6, 18, 44, 46, 51 AND 52). SN 79-082,974. PUB. 1-18-2011. FILED 5-7-2010.
- 3,940,023 ( *See Class 1 for this trademark*).
- 3,940,030. **SYMETIS (STANDARD CHARACTER)**. SYMETIS SA, MULTIPLE CLASS, (INT. CLS. 5, 10 AND 42), (U.S. CLS. 6, 18, 26, 39, 44, 46, 51, 52, 100 AND 101). SN 79-084,419. PUB. 1-18-2011. FILED 6-1-2010.
- 3,940,033. **SKYLOTEC AND DESIGN**. SKYLOTEC GMBH, MULTIPLE CLASS, (INT. CLS. 5, 9, 10, 18, 22, 25, 28 AND 37), (U.S. CLS. 1, 2, 3, 6, 7, 18, 19, 21, 22, 23, 26, 36, 38, 39, 41, 42, 44, 46, 50, 51, 52, 100, 103 AND 106). SN 79-084,505. PUB. 1-18-2011. FILED 2-25-2010.
- 3,940,053. **LIGASANO (STANDARD CHARACTER)**. LIGAMED MEDICAL PRODUKTE GMBH, (U.S. CLS. 6, 18, 44, 46, 51 AND 52). SN 79-085,840. PUB. 1-18-2011. FILED 2-18-2010.
- 3,940,069 ( *See Class 1 for this trademark*).
- 3,940,084. **COLADO CC (STANDARD CHARACTER)**. IVOCLAR VIVADENT, INC., (U.S. CLS. 6, 18, 44, 46, 51 AND 52). SN 85-003,920. PUB. 1-18-2011. FILED 4-1-2010.
- 3,940,088. **MXI (STANDARD CHARACTER)**. MXI CORP., MULTIPLE CLASS, (INT. CLS. 5, 30 AND 35), (U.S. CLS. 6, 18, 44, 46, 51, 52, 100, 101 AND 102). SN 85-005,884. PUB. 1-18-2011. FILED 4-4-2010.
- 3,940,089. **XOCAI (STANDARD CHARACTER)**. MXI CORP., MULTIPLE CLASS, (INT. CLS. 5, 32 AND 35), (U.S. CLS. 6, 18, 44, 45, 46, 48, 51, 52, 100, 101 AND 102). SN 85-005,885. PUB. 1-18-2011. FILED 4-4-2010.
- 3,940,106. **DERMA LIPID (STANDARD CHARACTER)**. GENUINE HEALTH INC., (U.S. CLS. 6, 18, 44, 46, 51 AND 52). SN 85-013,985. PUB. 1-18-2011. FILED 4-14-2010.
- 3,940,144. **HUISONG THE SCIENCE OF HEALTH NATURALLY AND DESIGN**. HUISONG PHARMACEUTICALS, (U.S. CLS. 6, 18, 44, 46, 51 AND 52). SN 85-031,337. PUB. 1-18-2011. FILED 5-6-2010.
- 3,940,157. **AMISH ORIGINS (STANDARD CHARACTER)**. AMISH ORIGINS, LLC, (U.S. CLS. 6, 18, 44, 46, 51 AND 52). SN 85-035,537. PUB. 1-18-2011. FILED 5-11-2010.
- 3,940,185. **DUET DHA COMPLETE (STANDARD CHARACTER)**. XANODYNE PHARMACEUTICALS, INC., (U.S. CLS. 6, 18, 44, 46, 51 AND 52). SN 85-044,019. PUB. 1-18-2011. FILED 5-20-2010.
- 3,940,216. **DIABREAD (STYLIZED)**. PABISAN, S.A. DE C.V., MULTIPLE CLASS, (INT. CLS. 5 AND 30), (U.S. CLS. 6, 18, 44, 46, 51 AND 52). SN 85-055,127. PUB. 1-18-2011. FILED 6-4-2010.
- 3,940,266. **MUSCLE FUEL THE ORIGINAL FUEL (STANDARD CHARACTER)**. THOMAS M. STEFFAN, INC., AKA STEFFCO INTERNATIONAL CORPORATION, (U.S. CLS. 6, 18, 44, 46, 51 AND 52). SN 85-068,927. PUB. 1-18-2011. FILED 6-22-2010.
- 3,940,269 ( *See Class 3 for this trademark*).
- 3,940,286. **LUMIPULSE (STANDARD CHARACTER)**. FUJIREBIO INC., MULTIPLE CLASS, (INT. CLS. 5 AND 10), (U.S. CLS. 6, 18, 26, 39, 44, 46, 51 AND 52). SN 85-074,104. PUB. 1-18-2011. FILED 6-29-2010.
- 3,940,486. **UNIHERBS AND DESIGN**. UNIHERBS, INC., (U.S. CLS. 6, 18, 44, 46, 51 AND 52). SN 85-097,563. PUB. 1-18-2011. FILED 7-31-2010.
- 3,940,572. **ULTRA UE AND DESIGN**. THOMPSON, BUD, DBA ULTRA ENTERPRISES, (U.S. CLS. 6, 18, 44, 46, 51 AND 52). SN 85-098,951. PUB. 1-18-2011. FILED 8-3-2010.
- 3,940,573. **SURE STEP (STANDARD CHARACTER)**. BW EQUINE PERFORMANCE, LLC, (U.S. CLS. 6, 18, 44, 46, 51 AND 52). SN 85-098,957. PUB. 1-18-2011. FILED 8-3-2010.
- 3,940,576. **HEAVENLY GREENS (STANDARD CHARACTER)**. CRUSADOR ENTERPRISES, INC., (U.S. CLS. 6, 18, 44, 46, 51 AND 52). SN 85-099,015. PUB. 1-18-2011. FILED 8-3-2010.
- 3,940,577. **TEMPLE CLEANSE (STANDARD CHARACTER)**. CRUSADOR ENTERPRISES, INC., (U.S. CLS. 6, 18, 44, 46, 51 AND 52). SN 85-099,025. PUB. 1-18-2011. FILED 8-3-2010.
- 3,940,612. **SMART BRAND PRODUCTS (STANDARD CHARACTER)**. OTC, INC., (U.S. CLS. 6, 18, 44, 46, 51 AND 52). SN 85-099,683. PUB. 1-18-2011. FILED 8-4-2010.
- 3,940,687. **ORALIEF (STANDARD CHARACTER)**. HTC

- CORP., AKA HEALING THRU CARING, INC., (U.S. CLS. 6, 18, 44, 46, 51 AND 52). SN 85-100,660. PUB. 1-18-2011. FILED 8-5-2010.
- 3,940,708. **XOVOLTIB (STANDARD CHARACTER)**. BOEHRINGER INGELHEIM INTERNATIONAL GMBH, (U.S. CLS. 6, 18, 44, 46, 51 AND 52). SN 85-100,914. PUB. 1-18-2011. FILED 8-5-2010.
- 3,940,711. **ZELOTEP (STANDARD CHARACTER)**. BOEHRINGER INGELHEIM INTERNATIONAL GMBH, (U.S. CLS. 6, 18, 44, 46, 51 AND 52). SN 85-100,963. PUB. 1-18-2011. FILED 8-5-2010.
- 3,940,713. **ZELCIVOL (STANDARD CHARACTER)**. BOEHRINGER INGELHEIM INTERNATIONAL GMBH, (U.S. CLS. 6, 18, 44, 46, 51 AND 52). SN 85-100,979. PUB. 1-18-2011. FILED 8-5-2010.
- 3,940,718. **VOLSEREB (STANDARD CHARACTER)**. BOEHRINGER INGELHEIM INTERNATIONAL GMBH, (U.S. CLS. 6, 18, 44, 46, 51 AND 52). SN 85-100,996. PUB. 1-18-2011. FILED 8-5-2010.
- 3,940,778. **ARSENAL X (STANDARD CHARACTER)**. BOND LABORATORIES, INC., (U.S. CLS. 6, 18, 44, 46, 51 AND 52). SN 85-101,995. PUB. 1-18-2011. FILED 8-6-2010.
- 3,940,784. **BODY GENETICS (STANDARD CHARACTER)**. CHRISTIANO JOSEPH A, (U.S. CLS. 6, 18, 44, 46, 51 AND 52). SN 85-102,042. PUB. 1-18-2011. FILED 8-6-2010.
- 3,940,896. **SOYACEN (STANDARD CHARACTER)**. ZUNIGA CHAVEZ, ALVARO JAIME, (U.S. CLS. 6, 18, 44, 46, 51 AND 52). SN 85-112,493. PUB. 1-18-2011. FILED 8-20-2010.
- 3,940,928. **MISCELLANEOUS DESIGN**. INNOVATION VENTURES, LLC, MULTIPLE CLASS, (INT. CLS. 5 AND 32), (U.S. CLS. 6, 18, 44, 45, 46, 48, 51 AND 52). SN 85-124,847. PUB. 1-18-2011. FILED 9-8-2010.
- 3,940,929. **MISCELLANEOUS DESIGN**. INNOVATION VENTURES, LLC, MULTIPLE CLASS, (INT. CLS. 5 AND 32), (U.S. CLS. 6, 18, 44, 45, 46, 48, 51 AND 52). SN 85-125,017. PUB. 1-18-2011. FILED 9-8-2010.
- 3,940,935. **CAPSCANADA (STANDARD CHARACTER)**. CAPSCANADA CORPORATION, (U.S. CLS. 6, 18, 44, 46, 51 AND 52). SN 85-128,055. PUB. 1-18-2011. FILED 9-13-2010.
- 3,940,938. **CAPSCANADA AND DESIGN**. CAPSCANADA CORPORATION, (U.S. CLS. 6, 18, 44, 46, 51 AND 52). SN 85-128,217. PUB. 1-18-2011. FILED 9-13-2010.
- 3,940,946. **MISCELLANEOUS DESIGN**. INNOVATION VENTURES, LLC, MULTIPLE CLASS, (INT. CLS. 5 AND 32), (U.S. CLS. 6, 18, 44, 45, 46, 48, 51 AND 52). SN 85-131,851. PUB. 1-18-2011. FILED 9-17-2010.
- 3,940,969. **PALEOMEAL (STANDARD CHARACTER)**. DESIGNS FOR HEALTH, INC., (U.S. CLS. 6, 18, 44, 46, 51 AND 52). SN 85-156,644. PUB. 1-18-2011. FILED 10-20-2010.

---

## CLASS 6—METAL GOODS

- 3,939,378. **MISCELLANEOUS DESIGN**. BULLSEYE S.D. LOCKS LLC, (U.S. CLS. 2, 12, 13, 14, 23, 25 AND 50). SN 76-703,505. PUB. 1-18-2011. FILED 6-24-2010.
- 3,939,379. **BULLSEYE (STANDARD CHARACTER)**. BULLSEYE S.D. LOCKS LLC, (U.S. CLS. 2, 12, 13, 14, 23, 25 AND 50). SN 76-703,506. PUB. 1-18-2011. FILED 6-24-2010.
- 3,939,390. **MISCELLANEOUS DESIGN**. FURUKAWA DENKI KOGYO KABUSHIKI KAISHA, DBA THE FURUKAWA ELECTRIC CO., LTD., MULTIPLE CLASS, (INT. CLS. 6, 9, 12 AND 17), (U.S. CLS. 1, 2, 5, 12, 13, 14, 19, 21, 23, 25, 26, 31, 35, 36, 38, 44 AND 50). SN 77-040,632. PUB. 1-18-2011. FILED 11-9-2006.
- 3,939,490. **PRG AND DESIGN**. PRODUCTION RESOURCE GROUP, L.L.C., MULTIPLE CLASS, (INT. CLS. 6, 7, 11, 19, 20, 37, 41 AND 42), (U.S. CLS. 1, 2, 12, 13, 14, 19, 21, 22, 23, 25, 31, 32, 33, 34, 35, 50, 100, 101, 103, 106 AND 107). SN 77-761,112. PUB. 1-18-2011. FILED 6-16-2009.
- 3,939,511. **AM 355 (STANDARD CHARACTER)**. ATI PROPERTIES, INC., (U.S. CLS. 2, 12, 13, 14, 23, 25 AND 50). SN 77-791,909. PUB. 1-18-2011. FILED 7-29-2009.
- 3,939,515. **MODULAR SIMPLE (STANDARD CHARACTER)**. FORMAT TRESORBAN GMBH & CO. KG, MULTIPLE CLASS, (INT. CLS. 6 AND 9), (U.S. CLS. 2, 12, 13, 14, 21, 23, 25, 26, 36, 38 AND 50). SN 77-794,790. PUB. 1-18-2011. FILED 7-31-2009.
- 3,939,569. **FABFARM MO FABULOUSITY FABRICATION FARMERS OF AMERICA AND DESIGN**. FAB FARM, LLC, DBA FABRICATION FARMERS OF AMERICA, MULTIPLE CLASS, (INT. CLS. 6, 16, 20, 21 AND 25), (U.S. CLS. 2, 5, 12, 13, 14, 22, 23, 25, 29, 30, 32, 33, 37, 38, 39, 40 AND 50). SN 77-858,880. PUB. 1-18-2011. FILED 10-27-2009.
- 3,939,628. **JGI INTERLOCK CONCEALMENT SYSTEMS AND DESIGN**. J G INNOVATIONS, INC., (U.S. CLS. 2, 12, 13, 14, 23, 25 AND 50). SN 77-914,727. PUB. 1-18-2011. FILED 1-19-2010.
- 3,939,719. **FV (STANDARD CHARACTER)**. RYTEC CORPORATION, (U.S. CLS. 2, 12, 13, 14, 23, 25 AND 50). SN 77-935,995. PUB. 1-18-2011. FILED 2-15-2010.
- 3,939,720. **LH (STANDARD CHARACTER)**. RYTEC CORPORATION, (U.S. CLS. 2, 12, 13, 14, 23, 25 AND 50). SN 77-936,003. PUB. 1-18-2011. FILED 2-15-2010.
- 3,939,782. **OUTSTORE (STANDARD CHARACTER)**. PETER GEORGE GUNN, MULTIPLE CLASS, (INT. CLS. 6, 37 AND 42), (U.S. CLS. 2, 12, 13, 14, 23, 25, 50, 100, 101, 103 AND 106). SN 77-949,539. PUB. 1-18-2011. FILED 3-3-2010.
- 3,939,797. **"V" MARK ON NAIL HEAD AND DESIGN**. FARRIER PRODUCT DISTRIBUTION, INC., (U.S. CLS. 2, 12, 13, 14, 23, 25 AND 50). SN 77-952,731. PUB. 1-18-2011. FILED 3-8-2010.
- 3,939,833. **STAMPED FITTINGS (STANDARD CHARACTER)**. STAMPED FITTINGS, INC., (U.S. CLS. 2, 12, 13, 14, 23, 25 AND 50). SN 77-963,179. PUB. 1-18-2011. FILED 3-19-2010.
- 3,939,847. **SUPER HINGE SUPER DUTY HINGE SYSTEM AND DESIGN**. OMNI CONTAINMENT SYSTEMS, LLC., (U.S. CLS. 2, 12, 13, 14, 23, 25 AND 50). SN 77-965,401. PUB. 1-18-2011. FILED 3-22-2010.
- 3,939,896. **JONALLOY (STYLIZED)**. MAES JONKER, NAAMLOZE VENNOOTSCHAP, MULTIPLE CLASS, (INT. CLS. 6, 7 AND 8), (U.S. CLS. 2, 12, 13, 14, 19, 21, 23, 25, 28, 31, 34, 35, 44 AND 50). SN 79-070,854. PUB. 1-18-2011. FILED 5-14-2009.
- 3,939,911. **PRIMA AND DESIGN**. NORDIC ENTRY NETWORK AB, MULTIPLE CLASS, (INT. CLS. 6, 17 AND 19), (U.S. CLS. 1, 2, 5, 12, 13, 14, 23, 25, 33, 35 AND 50). SN 79-074,096. PUB. 1-18-2011. FILED 7-28-2009.
- 3,939,991. **FM 52I (STANDARD CHARACTER)**. THYSSENKRUPP VDM GMBH, (U.S. CLS. 2, 12, 13, 14, 23, 25 AND 50). SN 79-081,244. PUB. 1-18-2011. FILED 2-11-2010.
- 3,939,992. **EN 52I (STANDARD CHARACTER)**. THYSSENKRUPP VDM GMBH, (U.S. CLS. 2, 12, 13, 14, 23, 25 AND 50). SN 79-081,292. PUB. 1-18-2011. FILED 2-11-2010.
- 3,939,999. **CAME (STANDARD CHARACTER)**. CAME GROUP S.P.A., MULTIPLE CLASS, (INT. CLS. 6, 7, 9, 19, 35, 37, 41, 42 AND 45), (U.S. CLS. 1, 2, 12, 13, 14, 19, 21, 23, 25, 26, 31, 33, 34, 35, 36, 38, 50, 100, 101, 102, 103, 106 AND 107). SN 79-081,747. PUB. 1-18-2011. FILED 2-10-2010.
- 3,940,159. **ECO ECO WINDOW SYSTEMS AND DESIGN**. ECO WINDOW SYSTEMS, LLC, (U.S. CLS. 2, 12, 13, 14, 23, 25 AND 50). SN 85-035,863. PUB. 1-18-2011. FILED 5-11-2010.
- 3,940,228. **JÄGER BARREL (STANDARD CHARACTER)**. MAST JÄGERMEISTER AG, MULTIPLE CLASS, (INT. CLS. 6, 9, 16, 24 AND 33), (U.S. CLS. 2, 5, 12, 13, 14, 21, 22, 23, 25, 26, 29, 36, 37, 38, 42, 47, 49 AND 50). SN 85-057,580. PUB. 1-18-2011. FILED 6-8-2010.
- 3,940,338. **V (STYLIZED)**. HARDWARE RESOURCES, INC., (U.S. CLS. 2, 12, 13, 14, 23, 25 AND 50). SN 85-086,297. PUB. 1-18-2011. FILED 7-16-2010.
- 3,940,517. **DOORSAVER (STANDARD CHARACTER)**. PERFECT PRODUCTS, (U.S. CLS. 2, 12, 13, 14, 23, 25 AND 50). SN 85-098,033. PUB. 1-18-2011. FILED 8-2-2010.

---

## CLASS 7—MACHINERY

- 3,939,408. **GMC CARBON FIBRE AND DESIGN**. POWER BOX AG, (U.S. CLS. 13, 19, 21, 23, 31, 34 AND 35). SN 77-325,276. PUB. 1-18-2011. FILED 11-8-2007.
- 3,939,490 ( *See Class 6 for this trademark*).
- 3,939,507. **MISCELLANEOUS DESIGN**. PRECISIONEERING LIMITED, MULTIPLE CLASS, (INT. CLS. 7 AND 40), (U.S. CLS. 13, 19, 21, 23, 31, 34, 35, 100, 103 AND 106). SN 77-787,073. PUB. 1-18-2011. FILED 7-22-2009.

- 3,939,509. **PURE WATER AND DESIGN**. PURE AND SECURE LLC, MULTIPLE CLASS, (INT. CLS. 7 AND 11), (U.S. CLS. 13, 19, 21, 23, 31, 34 AND 35). SN 77-787,684. PUB. 1-18-2011. FILED 7-23-2009.
- 3,939,518. **AOD (STANDARD CHARACTER)**. PRICE PUMP MANUFACTURING COMPANY, (U.S. CLS. 13, 19, 21, 23, 31, 34 AND 35). SN 77-796,791. PUB. 1-18-2011. FILED 8-4-2009.
- 3,939,525. **MISCELLANEOUS DESIGN**. RENNSTEIG WERKZEUGE GMBH, MULTIPLE CLASS, (INT. CLS. 7, 8, 9 AND 20), (U.S. CLS. 2, 13, 19, 21, 22, 23, 25, 26, 28, 31, 32, 34, 35, 36, 38, 44 AND 50). SN 77-800,467. PUB. 1-18-2011. FILED 8-10-2009.
- 3,939,594. **SEISMIC STIMULATION (STANDARD CHARACTER)**. APPLIED SEISMIC RESEARCH CORPORATION, (U.S. CLS. 13, 19, 21, 23, 31, 34 AND 35). SN 77-882,666. PUB. 1-18-2011. FILED 11-30-2009.
- 3,939,688. **BLACK ONYX GASKETS (STANDARD CHARACTER)**. RIVER CITY DIESEL, LLC, (U.S. CLS. 13, 19, 21, 23, 31, 34 AND 35). SN 77-929,927. PUB. 1-18-2011. FILED 2-7-2010.
- 3,939,780. **FOAMPLY (STANDARD CHARACTER)**. SUNSTAR ENGINEERING INC., (U.S. CLS. 13, 19, 21, 23, 31, 34 AND 35). SN 77-948,030. PUB. 1-18-2011. FILED 3-2-2010.
- 3,939,781. **TWINMAG (STANDARD CHARACTER)**. APPLIED MATERIALS GMBH & CO. KG, (U.S. CLS. 13, 19, 21, 23, 31, 34 AND 35). SN 77-948,998. PUB. 1-18-2011. FILED 3-3-2010.
- 3,939,881 ( *See Class 1 for this trademark*).
- 3,939,888. **ANSALDO (STANDARD CHARACTER)**. FINMECCANICA SOCIETA PER AZIONI, MULTIPLE CLASS, (INT. CLS. 7, 9, 11 AND 12), (U.S. CLS. 13, 19, 21, 23, 26, 31, 34, 35, 36, 38 AND 44). SN 79-067,131. PUB. 1-18-2011. FILED 6-9-2008.
- 3,939,896 ( *See Class 6 for this trademark*).
- 3,939,900. **E M AND DESIGN**. CONVERTEAM GROUP, MULTIPLE CLASS, (INT. CLS. 7, 9 AND 40), (U.S. CLS. 13, 19, 21, 23, 26, 31, 34, 35, 36, 38, 100, 103 AND 106). SN 79-072,393. PUB. 1-18-2011. FILED 4-24-2009.
- 3,939,906. **HISPD (STANDARD CHARACTER)**. MAGNETI MARELLI S.P.A., MULTIPLE CLASS, (INT. CLS. 7, 9 AND 12), (U.S. CLS. 13, 19, 21, 23, 26, 31, 34, 35, 36, 38 AND 44). SN 79-073,292. PUB. 1-18-2011. FILED 7-24-2009.
- 3,939,912. **SITESTAR (STYLIZED)**. SITETEL SWEDEN AB, MULTIPLE CLASS, (INT. CLS. 7, 9, 11, 38, 39 AND 40), (U.S. CLS. 13, 19, 21, 23, 26, 31, 34, 35, 36, 38, 100, 101, 103, 104, 105 AND 106). SN 79-074,280. PUB. 1-18-2011. FILED 8-11-2009.
- 3,939,916. **NAERO (STYLIZED)**. BENEQ OY, MULTIPLE CLASS, (INT. CLS. 7 AND 9), (U.S. CLS. 13, 19, 21, 23, 26, 31, 34, 35, 36 AND 38). SN 79-074,722. PUB. 1-18-2011. FILED 9-3-2009.
- 3,939,929. **SJL (STANDARD CHARACTER)**. SMW-AUTOBLOK SPANNSYSTEME GMBH, (U.S. CLS. 13, 19, 21, 23, 31, 34 AND 35). SN 79-077,204. PUB. 1-18-2011. FILED 11-6-2009.
- 3,939,930. **CARBODIAM YOUR GLOBAL SOLUTION MANUFACTURER AND DESIGN**. CARBODIAM SA, (U.S. CLS. 13, 19, 21, 23, 31, 34 AND 35). SN 79-077,282. PUB. 1-18-2011. FILED 9-24-2009.
- 3,939,932. **XMF AND DESIGN**. HEBEI XMF TOOLS GROUP CO., LTD, (U.S. CLS. 13, 19, 21, 23, 31, 34 AND 35). SN 79-077,397. PUB. 1-18-2011. FILED 12-14-2009.
- 3,939,933 ( *See Class 1 for this trademark*).
- 3,939,943 ( *See Class 1 for this trademark*).
- 3,939,949. **FUNKE (STANDARD CHARACTER)**. FUNKE WÄRMEAUSTAUSCHER; APPARATEBAU GMBH, MULTIPLE CLASS, (INT. CLS. 7 AND 11), (U.S. CLS. 13, 19, 21, 23, 31, 34 AND 35). SN 79-079,564. PUB. 1-18-2011. FILED 2-4-2010.
- 3,939,970. **OKIYA (STYLIZED)**. OKIYA GROUP CO., LTD, (U.S. CLS. 13, 19, 21, 23, 31, 34 AND 35). SN 79-080,686. PUB. 1-18-2011. FILED 2-16-2010.
- 3,939,978. **SOFTSYNCHRO (STANDARD CHARACTER)**. EMUGE-WERK RICHARD GLIMPEL; GMBH & CO. KG; FABRIK FÜR PRÄZISIONSWERKZEUGE, (U.S. CLS. 13, 19, 21, 23, 31, 34 AND 35). SN 79-080,901. PUB. 1-18-2011. FILED 2-15-2010.
- 3,939,988. **HUBER (STYLIZED)**. PETER HUBER KÄLTETECHNISCHE MASCHINENBAU GMBH, MULTIPLE CLASS, (INT. CLS. 7, 9 AND 11), (U.S. CLS. 13, 19, 21, 23, 26, 31, 34, 35, 36 AND 38). SN 79-081,210. PUB. 1-18-2011. FILED 11-5-2009.
- 3,939,999 ( *See Class 6 for this trademark*).
- 3,940,005. **LM WIND POWER (STYLIZED)**. LM GLASFIBER A/S, MULTIPLE CLASS, (INT. CLS. 7 AND 17), (U.S. CLS. 1, 5, 12, 13, 19, 21, 23, 31, 34, 35 AND 50). SN 79-081,872. PUB. 1-18-2011. FILED 2-9-2010.
- 3,940,011. **STRATOCHROME (STANDARD CHARACTER)**. HUECK RHEINISCHE GMBH, MULTIPLE CLASS, (INT. CLS. 7, 37, 40 AND 42), (U.S. CLS. 13, 19, 21, 23, 31, 34, 35, 100, 101, 103 AND 106). SN 79-082,537. PUB. 1-18-2011. FILED 4-13-2010.
- 3,940,019. **PERFECTA (STANDARD CHARACTER)**. W & H DEUTSCHLAND GMBH, MULTIPLE CLASS, (INT. CLS. 7, 9 AND 10), (U.S. CLS. 13, 19, 21, 23, 26, 31, 34, 35, 36, 38, 39 AND 44). SN 79-083,050. PUB. 1-18-2011. FILED 3-23-2010.
- 3,940,055. **ACRON (STYLIZED)**. ACRON POWER TRANSMISSION (ZHEJIANG) CO., LTD., MULTIPLE CLASS, (INT. CLS. 7 AND 12), (U.S. CLS. 13, 19, 21, 23, 31, 34, 35 AND 44). SN 79-085,973. PUB. 1-18-2011. FILED 3-31-2010.
- 3,940,061. **SINA (STYLIZED)**. ROTH & RAU AG, MULTIPLE CLASS, (INT. CLS. 7, 9 AND 40), (U.S. CLS. 13, 19, 21, 23, 26, 31, 34, 35, 36, 38, 100, 103 AND 106). SN 79-086,697. PUB. 1-18-2011. FILED 6-7-2010.
- 3,940,062. **ENERCUBE (STANDARD CHARACTER)**. HTCER-AMIX S.A., MULTIPLE CLASS, (INT. CLS. 7 AND 9), (U.S. CLS. 13, 19, 21, 23, 26, 31, 34, 35, 36 AND 38). SN 79-086,895. PUB. 1-18-2011. FILED 8-5-2010.
- 3,940,093. **WYATT GATLING (STANDARD CHARACTER)**. TEDD CYCLE, INC., MULTIPLE CLASS, (INT. CLS. 7, 11 AND 12), (U.S. CLS. 13, 19, 21, 23, 31, 34, 35 AND 44). SN 85-006,387. PUB. 1-18-2011. FILED 4-5-2010.
- 3,940,104. **WYATT GATLING AND DESIGN**. TEDD CYCLE, INC., MULTIPLE CLASS, (INT. CLS. 7, 11 AND 12), (U.S. CLS. 13, 19, 21, 23, 31, 34, 35 AND 44). SN 85-013,541. PUB. 1-18-2011. FILED 4-14-2010.
- 3,940,262. **BEKA-MAX (STANDARD CHARACTER)**. BAIER & KÖPPEL GMBH & CO., MULTIPLE CLASS, (INT. CLS. 7 AND 12), (U.S. CLS. 13, 19, 21, 23, 31, 34, 35 AND 44). SN 85-066,326. PUB. 1-18-2011. FILED 6-18-2010.
- 3,940,387. **KEYSKIRT (STANDARD CHARACTER)**. SLIC TRADING COMPANY LIMITED, (U.S. CLS. 13, 19, 21, 23, 31, 34 AND 35). SN 85-093,457. PUB. 1-18-2011. FILED 7-27-2010.
- 3,940,394. **RUG BOSS (STANDARD CHARACTER)**. PULLMAN-HOLT CORPORATION, (U.S. CLS. 13, 19, 21, 23, 31, 34 AND 35). SN 85-093,720. PUB. 1-18-2011. FILED 7-27-2010.
- 3,940,451. **GROMAX (STANDARD CHARACTER)**. GROMAX ENTERPRISES CORPORATION, (U.S. CLS. 13, 19, 21, 23, 31, 34 AND 35). SN 85-096,907. PUB. 1-18-2011. FILED 7-30-2010.
- 3,940,503. **K AND DESIGN**. ECS DO BRASIL METALURGIA E PARTICIPAÇÕES LTDA., (U.S. CLS. 13, 19, 21, 23, 31, 34 AND 35). SN 85-097,766. PUB. 1-18-2011. FILED 8-2-2010.
- 3,940,507. **POWER FLEX (STANDARD CHARACTER)**. TECHTRONIC FLOOR CARE TECHNOLOGY LIMITED, (U.S. CLS. 13, 19, 21, 23, 31, 34 AND 35). SN 85-097,821. PUB. 1-18-2011. FILED 8-2-2010.
- 3,940,607. **WELDOUT (STANDARD CHARACTER)**. VIKING DRILL & TOOL, INC., (U.S. CLS. 13, 19, 21, 23, 31, 34 AND 35). SN 85-099,649. PUB. 1-18-2011. FILED 8-4-2010.
- 3,940,624. **SOFTOP (STANDARD CHARACTER)**. FAIRLANE TOOL COMPANY, INC. D/B/A FAIRLANE PRODUCTS, INC., (U.S. CLS. 13, 19, 21, 23, 31, 34 AND 35). SN 85-099,888. PUB. 1-18-2011. FILED 8-4-2010.
- 3,940,688. **ACCENT 470 (STANDARD CHARACTER)**. ACCENT PACKAGING INC., DBA ACCENT WIRE PRODUCTS, (U.S. CLS. 13, 19, 21, 23, 31, 34 AND 35). SN 85-100,667. PUB. 1-18-2011. FILED 8-5-2010.
- 3,940,717. **PAKPRESS (STANDARD CHARACTER)**. TIRE SERVICE EQUIPMENT MFG. CO., INC, (U.S. CLS. 13, 19, 21, 23, 31, 34 AND 35). SN 85-100,994. PUB. 1-18-2011. FILED 8-5-2010.

**CLASS 8—HAND TOOLS**

- 3,939,525 ( *See Class 7 for this trademark.*)  
 3,939,644. **NIGHT WATCHMAN (STANDARD CHARACTER)**. UNITED CUTLERY CORPORATION, (U.S. CLS. 23, 28 AND 44). SN 77-919,973. PUB. 1-18-2011. FILED 1-26-2010.  
 3,939,803. **DUCKBILL DECK WRECKER (STANDARD CHARACTER)**. FORRESTER MANUFACTURING COMPANY, INC., (U.S. CLS. 23, 28 AND 44). SN 77-954,683. PUB. 1-18-2011. FILED 3-9-2010.  
 3,939,882. **ROSTI MEPAL (STANDARD CHARACTER)**. MEPAL B.V., MULTIPLE CLASS, (INT. CLS. 8 AND 21), (U.S. CLS. 2, 13, 23, 28, 29, 30, 31, 33, 40, 44 AND 50). SN 79-059,117. PUB. 1-18-2011. FILED 7-28-2008.  
 3,939,896 ( *See Class 6 for this trademark.*)  
 3,939,903. **NOUVEL (STYLIZED)**. NOUVEL AG, TRIENGEN, MULTIPLE CLASS, (INT. CLS. 8, 11 AND 21), (U.S. CLS. 2, 13, 21, 23, 28, 29, 30, 31, 33, 34, 40, 44 AND 50). SN 79-072,835. PUB. 1-18-2011. FILED 4-28-2009.  
 3,939,905. **B BRUNO BARONTINI AND DESIGN**. KING OF KNIVES PTY LIMITED, MULTIPLE CLASS, (INT. CLS. 8 AND 21), (U.S. CLS. 2, 13, 23, 28, 29, 30, 33, 40, 44 AND 50). SN 79-073,198. PUB. 1-18-2011. FILED 7-4-2009.  
 3,939,950. **RING LOCK SYSTEM AND DESIGN**. CONSORZIO CON ATTIVITA' ESTERNA; FRA IMPRENDITORI COLLETTINAI; E FORBICIAI E FABBRICANTI; DI UTENSILERIA E SIMILI PER; LO SVILUPPO ECONOMICO DI PREMANA; E DELLA VALSASSINA (IN SHORT; CONSORZIO PREMAX), (U.S. CLS. 23, 28 AND 44). SN 79-079,781. PUB. 1-18-2011. FILED 1-25-2010.  
 3,940,326. **MARBLE'S SAFETY AXE CO. (STANDARD CHARACTER)**. PHILLIP S. MARTIN, DBA BLUE RIDGE KNIVES, (U.S. CLS. 23, 28 AND 44). SN 85-083,289. PUB. 1-18-2011. FILED 7-13-2010.  
 3,940,327. **M.S.A. CO. (STANDARD CHARACTER)**. PHILLIP S. MARTIN, DBA BLUE RIDGE KNIVES, (U.S. CLS. 23, 28 AND 44). SN 85-083,294. PUB. 1-18-2011. FILED 7-13-2010.  
 3,940,794. **BHK AND DESIGN**. BLIND HORSE KNIVES PARTNERSHIP, (U.S. CLS. 23, 28 AND 44). SN 85-102,246. PUB. 1-18-2011. FILED 8-6-2010.  
 3,940,811. **MICHAEL WAINWRIGHT (STANDARD CHARACTER)**. MICHAEL WAINWRIGHT, INC., (U.S. CLS. 23, 28 AND 44). SN 85-102,490. PUB. 1-18-2011. FILED 8-6-2010.

**CLASS 9—ELECTRICAL AND SCIENTIFIC APPARATUS**

- 3,939,349 ( *See Class 3 for this trademark.*)  
 3,939,362. **KSE (STANDARD CHARACTER)**. KOA SPEER ELECTRONICS, INC., (U.S. CLS. 21, 23, 26, 36 AND 38). SN 76-701,494. PUB. 1-18-2011. FILED 2-5-2010.  
 3,939,374. **KONVAX AND DESIGN**. KONVAX CORPORATION, MULTIPLE CLASS, (INT. CLS. 9 AND 42), (U.S. CLS. 21, 23, 26, 36, 38, 100 AND 101). SN 76-702,789. PUB. 1-18-2011. FILED 5-3-2010.  
 3,939,389. **SOFTPREANALYTICAL (STANDARD CHARACTER)**. SOFT COMPUTER CONSULTANTS, INC., (U.S. CLS. 21, 23, 26, 36 AND 38). SN 76-704,569. PUB. 1-18-2011. FILED 9-21-2010.  
 3,939,390 ( *See Class 6 for this trademark.*)  
 3,939,391. **MISCELLANEOUS DESIGN**. SIOS TECHNOLOGY, INC., (U.S. CLS. 21, 23, 26, 36 AND 38). SN 77-048,902. PUB. 11-27-2007. FILED 11-21-2006.  
 3,939,405. **PLAY! CHOCOBO AND DESIGN**. KABUSHIKI KAISHA SQUARE ENIX, TA SQUARE ENIX CO. LTD., MULTIPLE CLASS, (INT. CLS. 9, 16, 25 AND 28), (U.S. CLS. 2, 5, 21, 22, 23, 26, 29, 36, 37, 38, 39 AND 50). SN 77-290,724. PUB. 1-18-2011. FILED 9-27-2007.  
 3,939,406. **BOSS FROG'S (STANDARD CHARACTER)**. FROGMAN CHARTERS INC., MULTIPLE CLASS, (INT. CLS. 9, 28 AND 41), (U.S. CLS. 21, 22, 23, 26, 36, 38, 50, 100, 101 AND 107). SN 77-309,076. PUB. 4-29-2008. FILED 10-19-2007.  
 3,939,413. **DANGEROUS BOOK FOR BOYS (STYLIZED)**. HARPERCOLLINS PUBLISHERS LIMITED, MULTIPLE CLASS, (INT. CLS. 9 AND 41), (U.S. CLS. 21, 23, 26, 36, 38, 100, 101 AND 107). SN 77-403,759. PUB. 4-14-2009. FILED 2-22-2008.  
 3,939,414. **DANGEROUS BOOK FOR BOYS (STANDARD CHARACTER)**. HARPERCOLLINS PUBLISHERS LIMITED, MULTIPLE CLASS, (INT. CLS. 9 AND 41), (U.S. CLS. 21, 23, 26, 36, 38, 100, 101 AND 107). SN 77-403,764. PUB. 4-14-2009. FILED 2-22-2008.  
 3,939,421. **MISCELLANEOUS DESIGN**. INETCO SYSTEMS LIMITED, MULTIPLE CLASS, (INT. CLS. 9 AND 42), (U.S. CLS. 21, 23, 26, 36, 38, 100 AND 101). SN 77-464,904. PUB. 1-18-2011. FILED 5-2-2008.  
 3,939,422. **INETCO AND DESIGN**. INETCO SYSTEMS LIMITED, MULTIPLE CLASS, (INT. CLS. 9 AND 42), (U.S. CLS. 21, 23, 26, 36, 38, 100 AND 101). SN 77-464,907. PUB. 1-18-2011. FILED 5-2-2008.  
 3,939,424. **BUBBLEMESH (STANDARD CHARACTER)**. CIE-SPACE CORPORATION, (U.S. CLS. 21, 23, 26, 36 AND 38). SN 77-488,933. PUB. 1-18-2011. FILED 6-2-2008.  
 3,939,433. **WLA WORLD LIFE ALLIANCE (STYLIZED)**. RATH, DR. MATTHIAS, MULTIPLE CLASS, (INT. CLS. 9, 16, 41 AND 44), (U.S. CLS. 2, 5, 21, 22, 23, 26, 29, 36, 37, 38, 50, 100, 101 AND 107). SN 77-565,628. PUB. 1-18-2011. FILED 9-9-2008.  
 3,939,442. **TIME TAILOR (STANDARD CHARACTER)**. PRIME IMAGE DELAWARE, INC. D/B/A PRIME IMAGE, (U.S. CLS. 21, 23, 26, 36 AND 38). SN 77-629,378. PUB. 1-18-2011. FILED 12-9-2008.  
 3,939,446. **PARADIGM (STANDARD CHARACTER)**. PARADIGM SCIENCES LTD., MULTIPLE CLASS, (INT. CLS. 9, 41 AND 42), (U.S. CLS. 21, 23, 26, 36, 38, 100, 101 AND 107). SN 77-635,349. PUB. 1-18-2011. FILED 12-17-2008.  
 3,939,447. **MISCELLANEOUS DESIGN**. PARADIGM SCIENCES LTD., MULTIPLE CLASS, (INT. CLS. 9, 41 AND 42), (U.S. CLS. 21, 23, 26, 36, 38, 100, 101 AND 107). SN 77-635,366. PUB. 1-18-2011. FILED 12-17-2008.  
 3,939,452. **ACTIVINSPIRE (STANDARD CHARACTER)**. PROMETHEAN LIMITED, (U.S. CLS. 21, 23, 26, 36 AND 38). SN 77-661,430. PUB. 1-18-2011. FILED 2-2-2009.  
 3,939,453. **RADIANT COMMUNICATIONS CORPORATION (STANDARD CHARACTER)**. RADIANT COMMUNICATIONS CORPORATION, (U.S. CLS. 21, 23, 26, 36 AND 38). SN 77-671,716. PUB. 1-18-2011. FILED 2-17-2009.  
 3,939,457. **MEGA GRIP MAGIK MAGNET (STANDARD CHARACTER)**. DEPPEN, DAN, (U.S. CLS. 21, 23, 26, 36 AND 38). SN 77-683,245. PUB. 1-18-2011. FILED 3-4-2009.  
 3,939,467. **MELSOFT GT WORKS (STANDARD CHARACTER)**. MITSUBISHI ELECTRIC CORPORATION, (U.S. CLS. 21, 23, 26, 36 AND 38). SN 77-715,486. PUB. 1-18-2011. FILED 4-16-2009.  
 3,939,468. **MELSOFT GT DESIGNER (STANDARD CHARACTER)**. MITSUBISHI ELECTRIC CORPORATION, (U.S. CLS. 21, 23, 26, 36 AND 38). SN 77-715,512. PUB. 1-18-2011. FILED 4-16-2009.  
 3,939,474. **RAYZ (STANDARD CHARACTER)**. ECCA ENTERPRISES, INC., (U.S. CLS. 21, 23, 26, 36 AND 38). SN 77-727,259. PUB. 1-18-2011. FILED 5-1-2009.  
 3,939,502. **STAR FEVER AGENCY (STANDARD CHARACTER)**. THE RABBIT HOLE LIMITED, MULTIPLE CLASS, (INT. CLS. 9, 38 AND 41), (U.S. CLS. 21, 23, 26, 36, 38, 100, 101, 104 AND 107). SN 77-784,418. PUB. 1-18-2011. FILED 7-19-2009.  
 3,939,506. **VALUEPILOT (STANDARD CHARACTER)**. AUTO-ONLINE GMBH INFORMATIONSSYSTEME, MULTIPLE CLASS, (INT. CLS. 9, 35, 38, 39 AND 42), (U.S. CLS. 21, 23, 26, 36, 38, 100, 101, 102, 104 AND 105). SN 77-786,872. PUB. 1-18-2011. FILED 7-22-2009.  
 3,939,512. **XSENER (STANDARD CHARACTER)**. STEPAC L.A. LTD., (U.S. CLS. 21, 23, 26, 36 AND 38). SN 77-791,953. PUB. 1-18-2011. FILED 7-29-2009.  
 3,939,515 ( *See Class 6 for this trademark.*)  
 3,939,516. **TMT AND DESIGN**. THOMPSON TANK, INC., MULTIPLE CLASS, (INT. CLS. 9, 12, 35, 37, 40 AND 42), (U.S. CLS. 19, 21, 23, 26, 31, 35, 36, 38, 44, 100, 101, 102, 103 AND 106). SN 77-795,909. PUB. 1-18-2011. FILED 8-3-2009.  
 3,939,517. **S HEATSHIFT AND DESIGN**. THERMAPAK TECHNOLOGIES, INC., (U.S. CLS. 21, 23, 26, 36 AND 38). SN 77-795,956. PUB. 1-18-2011. FILED 8-3-2009.  
 3,939,519. **GMAT BUSINESS READY (STANDARD CHARACTER)**. GRADUATE MANAGEMENT ADMISSION COUN-

- CIL, (U.S. CLS. 21, 23, 26, 36 AND 38). SN 77-796,802. PUB. 1-18-2011. FILED 8-4-2009.
- 3,939,525 ( *See Class 7 for this trademark.*).
- 3,939,526. **JACKED AUTO THEFT TASK FORCE AND DESIGN.** A&E TELEVISION NETWORKS, LLC, MULTIPLE CLASS, (INT. CLS. 9 AND 41), (U.S. CLS. 21, 23, 26, 36, 38, 100, 101 AND 107). SN 77-807,379. PUB. 7-6-2010. FILED 8-18-2009.
- 3,939,534. **VISIONSTAT (STANDARD CHARACTER).** MOBILE AWARENESS, (U.S. CLS. 21, 23, 26, 36 AND 38). SN 77-811,630. PUB. 1-18-2011. FILED 8-24-2009.
- 3,939,535. **SENSESTAT (STANDARD CHARACTER).** MOBILE AWARENESS, (U.S. CLS. 21, 23, 26, 36 AND 38). SN 77-811,692. PUB. 1-18-2011. FILED 8-24-2009.
- 3,939,536. **PLAYBRAINS AND DESIGN.** PLAYBRAINS, INC., MULTIPLE CLASS, (INT. CLS. 9 AND 41), (U.S. CLS. 21, 23, 26, 36, 38, 100, 101 AND 107). SN 77-812,834. PUB. 1-18-2011. FILED 8-26-2009.
- 3,939,539. **RAYZ AND DESIGN.** ECCA ENTERPRISES, INC., (U.S. CLS. 21, 23, 26, 36 AND 38). SN 77-817,852. PUB. 1-18-2011. FILED 9-1-2009.
- 3,939,543. **MOBILEDJ (STANDARD CHARACTER).** BARISTA ENTERTAINMENT, LLC, DBA BARISTA ENTERTAINMENT, MULTIPLE CLASS, (INT. CLS. 9, 38 AND 41), (U.S. CLS. 21, 23, 26, 36, 38, 100, 101, 104 AND 107). SN 77-826,572. PUB. 1-18-2011. FILED 9-15-2009.
- 3,939,546. **DOUBLEMYSPEED (STANDARD CHARACTER).** CYBERDEFENDER CORPORATION, (U.S. CLS. 21, 23, 26, 36 AND 38). SN 77-831,517. PUB. 1-18-2011. FILED 9-21-2009.
- 3,939,561. **FLEXERA SOFTWARE (STYLIZED).** FLEXERA SOFTWARE, INC., MULTIPLE CLASS, (INT. CLS. 9 AND 42), (U.S. CLS. 21, 23, 26, 36, 38, 100 AND 101). SN 77-850,929. PUB. 1-18-2011. FILED 10-16-2009.
- 3,939,568. **LOCKDOWN (STANDARD CHARACTER).** TECH FRIENDS, INC., (U.S. CLS. 21, 23, 26, 36 AND 38). SN 77-858,045. PUB. 1-18-2011. FILED 10-27-2009.
- 3,939,585. **NETSWEEP (STANDARD CHARACTER).** NET-GAIN CORPORATION, (U.S. CLS. 21, 23, 26, 36 AND 38). SN 77-871,849. PUB. 1-18-2011. FILED 11-13-2009.
- 3,939,586. **TONY TONI TONÉ (STANDARD CHARACTER).** WIGGINS, D'WAYNE, MULTIPLE CLASS, (INT. CLS. 9 AND 41), (U.S. CLS. 21, 23, 26, 36, 38, 100, 101 AND 107). SN 77-872,014. PUB. 1-18-2011. FILED 11-13-2009.
- 3,939,591. **WORLD FASHION MUSICAL AND DESIGN.** JOHNSON, CHRISTINE JOAN, MULTIPLE CLASS, (INT. CLS. 9, 25 AND 41), (U.S. CLS. 21, 22, 23, 26, 36, 38, 39, 100, 101 AND 107). SN 77-881,451. PUB. 1-18-2011. FILED 11-27-2009.
- 3,939,603. **INTERACTION SIP STATION (STANDARD CHARACTER).** INTERACTIVE INTELLIGENCE, INC., (U.S. CLS. 21, 23, 26, 36 AND 38). SN 77-891,785. PUB. 1-18-2011. FILED 12-11-2009.
- 3,939,619. **THE REFLECTIONS (STANDARD CHARACTER).** DEACONS OF DOO-WOP, DBA THE REFLECTIONS, MULTIPLE CLASS, (INT. CLS. 9 AND 41), (U.S. CLS. 21, 23, 26, 36, 38, 100, 101 AND 107). SN 77-907,584. PUB. 1-18-2011. FILED 1-8-2010.
- 3,939,620. **VOCADO (STANDARD CHARACTER).** VOCADO, LLC, FORMERLY VSM SYSTEMS, LLC, MULTIPLE CLASS, (INT. CLS. 9 AND 42), (U.S. CLS. 21, 23, 26, 36, 38, 100 AND 101). SN 77-909,273. PUB. 1-18-2011. FILED 1-11-2010.
- 3,939,621. **IOC (STANDARD CHARACTER).** CADENT LTD, (U.S. CLS. 21, 23, 26, 36 AND 38). SN 77-909,944. PUB. 1-18-2011. FILED 1-12-2010.
- 3,939,622. **IOC AND DESIGN.** CADENT LTD, (U.S. CLS. 21, 23, 26, 36 AND 38). SN 77-909,966. PUB. 1-18-2011. FILED 1-12-2010.
- 3,939,629 ( *See Class 3 for this trademark.*).
- 3,939,631. **BLOGINSONG.COM A CAMILLE BRIGHT-SMTH PROJECT AND DESIGN.** BLOGINSONG LLC, (U.S. CLS. 21, 23, 26, 36 AND 38). SN 77-915,121. PUB. 1-18-2011. FILED 1-19-2010.
- 3,939,649. **PZD (STANDARD CHARACTER).** TAMRON CO., LTD., (U.S. CLS. 21, 23, 26, 36 AND 38). SN 77-922,030. PUB. 1-18-2011. FILED 1-28-2010.
- 3,939,650. **AQUILON (STANDARD CHARACTER).** AQUILON SOFTWARE INC., (U.S. CLS. 21, 23, 26, 36 AND 38). SN 77-922,032. PUB. 1-18-2011. FILED 1-28-2010.
- 3,939,695. **LIGHTWISE (STANDARD CHARACTER).** IMAGING SOLUTIONS GROUP OF NY, INC., (U.S. CLS. 21, 23, 26, 36 AND 38). SN 77-931,325. PUB. 1-18-2011. FILED 2-9-2010.
- 3,939,698. **ABSU (STANDARD CHARACTER).** GIVENS, RUSSELL, MULTIPLE CLASS, (INT. CLS. 9 AND 41), (U.S. CLS. 21, 23, 26, 36, 38, 100, 101 AND 107). SN 77-931,832. PUB. 1-18-2011. FILED 2-9-2010.
- 3,939,710. **LOXOGON (STANDARD CHARACTER).** LOXOGON, INC., (U.S. CLS. 21, 23, 26, 36 AND 38). SN 77-934,957. PUB. 1-18-2011. FILED 2-12-2010.
- 3,939,713. **MINGLESTICK (STANDARD CHARACTER).** LIFE-SYNC MEDIA GROUP INC., (U.S. CLS. 21, 23, 26, 36 AND 38). SN 77-935,306. PUB. 1-18-2011. FILED 2-13-2010.
- 3,939,716. **V CO VICTORY COLLECTION AND DESIGN.** EAGLE EYEWEAR, INC., (U.S. CLS. 21, 23, 26, 36 AND 38). SN 77-935,697. PUB. 1-18-2011. FILED 2-15-2010.
- 3,939,723. **LUCKY TIGER (STANDARD CHARACTER).** ARISTOCRAT TECHNOLOGIES AUSTRALIA PTY LTD., (U.S. CLS. 21, 23, 26, 36 AND 38). SN 77-936,332. PUB. 1-18-2011. FILED 2-16-2010.
- 3,939,725. **WILD SPLASH (STANDARD CHARACTER).** ARISTOCRAT TECHNOLOGIES AUSTRALIA PTY LTD., (U.S. CLS. 21, 23, 26, 36 AND 38). SN 77-936,399. PUB. 1-18-2011. FILED 2-16-2010.
- 3,939,726. **SALMON RAPIDS (STANDARD CHARACTER).** ARISTOCRAT TECHNOLOGIES AUSTRALIA PTY LTD., (U.S. CLS. 21, 23, 26, 36 AND 38). SN 77-936,453. PUB. 1-18-2011. FILED 2-16-2010.
- 3,939,761. **FIREBOY-XINTEX (STANDARD CHARACTER).** FIREBOY-XINTEX, INC., (U.S. CLS. 21, 23, 26, 36 AND 38). SN 77-942,339. PUB. 1-18-2011. FILED 2-23-2010.
- 3,939,763. **TRANSLATE NOW! (STANDARD CHARACTER).** RENKARA MEDIA GROUP, (U.S. CLS. 21, 23, 26, 36 AND 38). SN 77-942,861. PUB. 1-18-2011. FILED 2-23-2010.
- 3,939,777. **ONGRID AND DESIGN.** BLACK, ANDREW, MULTIPLE CLASS, (INT. CLS. 9, 35 AND 41), (U.S. CLS. 21, 23, 26, 36, 38, 100, 101, 102 AND 107). SN 77-947,149. PUB. 1-18-2011. FILED 3-1-2010.
- 3,939,778. **IMPERIAL HOUSE (STANDARD CHARACTER).** ARISTOCRAT TECHNOLOGIES AUSTRALIA PTY LTD., (U.S. CLS. 21, 23, 26, 36 AND 38). SN 77-947,159. PUB. 1-18-2011. FILED 3-1-2010.
- 3,939,805. **INSTA LINK (STANDARD CHARACTER).** LAMOTTE CHEMICAL PRODUCTS COMPANY, (U.S. CLS. 21, 23, 26, 36 AND 38). SN 77-955,914. PUB. 1-18-2011. FILED 3-10-2010.
- 3,939,815. **THINKBUZAN (STANDARD CHARACTER).** THE BUZAN ORGANISATION LIMITED, MULTIPLE CLASS, (INT. CLS. 9, 16 AND 41), (U.S. CLS. 2, 5, 21, 22, 23, 26, 29, 36, 37, 38, 50, 100, 101 AND 107). SN 77-958,637. PUB. 1-18-2011. FILED 3-15-2010.
- 3,939,828. **JACKPOT JACK (STANDARD CHARACTER).** ARISTOCRAT TECHNOLOGIES AUSTRALIA PTY LTD., (U.S. CLS. 21, 23, 26, 36 AND 38). SN 77-962,009. PUB. 1-18-2011. FILED 3-18-2010.
- 3,939,853. **ROOM SERVICE CONCERTO (STANDARD CHARACTER).** THE CBORD GROUP, INC., (U.S. CLS. 21, 23, 26, 36 AND 38). SN 77-966,934. PUB. 1-18-2011. FILED 3-24-2010.
- 3,939,869. **IT'S FIVE O'CLOCK SOMEWHERE (STANDARD CHARACTER).** JB INTELLECTUAL PROPERTY, LLC, (U.S. CLS. 21, 23, 26, 36 AND 38). SN 78-602,819. PUB. 1-18-2011. FILED 4-6-2005.
- 3,939,880. **SI AND DESIGN.** SIEGFRIED RITTER, (U.S. CLS. 21, 23, 26, 36 AND 38). SN 79-041,900. PUB. 1-19-2010. FILED 7-13-2007.
- 3,939,881 ( *See Class 1 for this trademark.*).
- 3,939,888 ( *See Class 7 for this trademark.*).
- 3,939,889. **ENERTEC (STYLIZED).** ZODIAC DATA SYSTEMS, (U.S. CLS. 21, 23, 26, 36 AND 38). SN 79-067,348. PUB. 1-18-2011. FILED 4-23-2008.
- 3,939,890. **ABLETON (STANDARD CHARACTER).** ABLETON AG, MULTIPLE CLASS, (INT. CLS. 9, 15, 16, 18, 25, 35, 38, 39, 40, 41, 42 AND 45), (U.S. CLS. 1, 2, 3, 5, 21, 22, 23, 26, 29, 36, 37, 38, 39, 41, 50, 100, 101, 102, 103, 104, 105, 106 AND 107). SN 79-067,917. PUB. 1-18-2011. FILED 8-18-2008.
- 3,939,895. **TERIMAYO AND DESIGN.** CROWN CREATIVE



- CO., LTD., MULTIPLE CLASS, (INT. CLS. 9, 14, 16, 18, 24, 25 AND 28), (U.S. CLS. 1, 2, 3, 5, 21, 22, 23, 26, 27, 28, 29, 36, 37, 38, 39, 41, 42 AND 50). SN 79-070,341. PUB. 1-18-2011. FILED 12-3-2008.
- 3,939,898. **DINACELL ELECTRÓNICA AND DESIGN**. DINACELL ELECTRONICA SL, MULTIPLE CLASS, (INT. CLS. 9, 35 AND 42), (U.S. CLS. 21, 23, 26, 36, 38, 100, 101 AND 102). SN 79-072,008. PUB. 1-18-2011. FILED 2-25-2009.
- 3,939,899. **A—GUIDANCE AND DESIGN**. ANA - AEROPORTOS DE PORTUGAL, S.A., MULTIPLE CLASS, (INT. CLS. 9, 36, 38 AND 39), (U.S. CLS. 21, 23, 26, 36, 38, 100, 101, 102, 104 AND 105). SN 79-072,179. PUB. 1-18-2011. FILED 6-2-2009.
- 3,939,900 ( *See Class 7 for this trademark*).
- 3,939,904. **RTS EXCHANGE (STYLIZED)**. OPEN JOINT STOCK COMPANY; "RUSSIAN TRADING SYSTEM"; STOCK EXCHANGE, MULTIPLE CLASS, (INT. CLS. 9, 16, 35 AND 36), (U.S. CLS. 2, 5, 21, 22, 23, 26, 29, 36, 37, 38, 50, 100, 101 AND 102). SN 79-072,944. PUB. 1-18-2011. FILED 5-25-2009.
- 3,939,906 ( *See Class 7 for this trademark*).
- 3,939,907 ( *See Class 5 for this trademark*).
- 3,939,909. **PILOTSYNC (STANDARD CHARACTER)**. MODESAT COMMUNICATIONS OÜ, MULTIPLE CLASS, (INT. CLS. 9, 38 AND 42), (U.S. CLS. 21, 23, 26, 36, 38, 100, 101 AND 104). SN 79-073,829. PUB. 1-18-2011. FILED 4-30-2009.
- 3,939,910. **AMEE AND DESIGN**. AMEE UK LIMITED, MULTIPLE CLASS, (INT. CLS. 9, 35, 42 AND 45), (U.S. CLS. 21, 23, 26, 36, 38, 100, 101 AND 102). SN 79-073,940. PUB. 1-18-2011. FILED 5-28-2009.
- 3,939,912 ( *See Class 7 for this trademark*).
- 3,939,913 ( *See Class 3 for this trademark*).
- 3,939,914. **SUPERTUBE (STANDARD CHARACTER)**. SCHWANK GMBH, MULTIPLE CLASS, (INT. CLS. 9 AND 11), (U.S. CLS. 13, 21, 23, 26, 31, 34, 36 AND 38). SN 79-074,602. PUB. 1-18-2011. FILED 10-1-2009.
- 3,939,916 ( *See Class 7 for this trademark*).
- 3,939,920. **EASYVISTA (STANDARD CHARACTER)**. STAFF AND LINE, MULTIPLE CLASS, (INT. CLS. 9, 35, 38 AND 42), (U.S. CLS. 21, 23, 26, 36, 38, 100, 101, 102 AND 104). SN 79-075,648. PUB. 1-18-2011. FILED 7-31-2009.
- 3,939,921. **MAKE IT EASY (STANDARD CHARACTER)**. STAFF AND LINE, MULTIPLE CLASS, (INT. CLS. 9, 35, 38 AND 42), (U.S. CLS. 21, 23, 26, 36, 38, 100, 101, 102 AND 104). SN 79-075,649. PUB. 1-18-2011. FILED 7-31-2009.
- 3,939,925. **BIDDING BUZZ (STANDARD CHARACTER)**. BIDDING BUZZ GLOBAL LIMITED, MULTIPLE CLASS, (INT. CLS. 9, 16, 35 AND 41), (U.S. CLS. 2, 5, 21, 22, 23, 26, 29, 36, 37, 38, 50, 100, 101, 102 AND 107). SN 79-076,992. PUB. 1-18-2011. FILED 10-23-2009.
- 3,939,926. **RETMARKER AUTOMATIC DETECTION OF RETINAL CHANGES AND DESIGN**. CRITICAL HEALTH, S.A., (U.S. CLS. 21, 23, 26, 36 AND 38). SN 79-077,128. PUB. 1-18-2011. FILED 11-11-2009.
- 3,939,927. **RETMARKERDR BIOMARKER FOR DIABETIC RETINOPATHY PROGRESSION AND DESIGN**. CRITICAL HEALTH, S.A., (U.S. CLS. 21, 23, 26, 36 AND 38). SN 79-077,129. PUB. 1-18-2011. FILED 11-11-2009.
- 3,939,933 ( *See Class 1 for this trademark*).
- 3,939,936 ( *See Class 3 for this trademark*).
- 3,939,939. **YELLO SPARZÄHLER (STANDARD CHARACTER)**. YELLO STROM; VERWALTUNGSGESELLSCHAFT MBH, MULTIPLE CLASS, (INT. CLS. 9, 35, 36, 37, 38 AND 42), (U.S. CLS. 21, 23, 26, 36, 38, 100, 101, 102, 103, 104 AND 106). SN 79-078,665. PUB. 1-18-2011. FILED 8-14-2009.
- 3,939,940. **MESSKO (STANDARD CHARACTER)**. MASCHINENFABRIK REINHAUSEN GMBH, MULTIPLE CLASS, (INT. CLS. 9, 37 AND 42), (U.S. CLS. 21, 23, 26, 36, 38, 100, 101, 103 AND 106). SN 79-078,775. PUB. 1-18-2011. FILED 12-10-2009.
- 3,939,942 ( *See Class 2 for this trademark*).
- 3,939,948. **GONSIN (STYLIZED)**. FOSHAN GONSIN; DIGITAL CONFERENCE EQUIPMENT CO., LTD., (U.S. CLS. 21, 23, 26, 36 AND 38). SN 79-079,540. PUB. 1-18-2011. FILED 12-29-2009.
- 3,939,958. **IDENTIVE GROUP AND DESIGN**. SCM MICROSYSTEMS GMBH, MULTIPLE CLASS, (INT. CLS. 9 AND 42), (U.S. CLS. 21, 23, 26, 36, 38, 100 AND 101). SN 79-080,328. PUB. 1-18-2011. FILED 2-3-2010.
- 3,939,969. **SMOOKZZ (STANDARD CHARACTER)**. SMOOKZZ LICENCE B.V., MULTIPLE CLASS, (INT. CLS. 9 AND 34), (U.S. CLS. 2, 8, 9, 17, 21, 23, 26, 36 AND 38). SN 79-080,641. PUB. 1-18-2011. FILED 12-21-2009.
- 3,939,971. **SAVOX (STANDARD CHARACTER)**. SAVOX COMMUNICATIONS OY AB (LTD), MULTIPLE CLASS, (INT. CLS. 9, 35, 36, 37, 38 AND 42), (U.S. CLS. 21, 23, 26, 36, 38, 100, 101, 102, 103, 104 AND 106). SN 79-080,687. PUB. 1-18-2011. FILED 1-28-2010.
- 3,939,975. **ALGODOO (STANDARD CHARACTER)**. ALGOR-YX SIMULATION AB, MULTIPLE CLASS, (INT. CLS. 9 AND 41), (U.S. CLS. 21, 23, 26, 36, 38, 100, 101 AND 107). SN 79-080,817. PUB. 1-18-2011. FILED 2-16-2010.
- 3,939,976. **JILION (STANDARD CHARACTER)**. MEHDI AMINIAN, MULTIPLE CLASS, (INT. CLS. 9 AND 42), (U.S. CLS. 21, 23, 26, 36, 38, 100 AND 101). SN 79-080,844. PUB. 1-18-2011. FILED 2-17-2010.
- 3,939,979. **FLEISCHMANN (STYLIZED)**. MODELLEISENBAHN HOLDING GMBH, MULTIPLE CLASS, (INT. CLS. 9, 11 AND 28), (U.S. CLS. 13, 21, 22, 23, 26, 31, 34, 36, 38 AND 50). SN 79-081,051. PUB. 1-18-2011. FILED 3-11-2010.
- 3,939,980 ( *See Class 1 for this trademark*).
- 3,939,988 ( *See Class 7 for this trademark*).
- 3,939,990. **BRAINDISTRICT AND DESIGN**. BRAINDISTRICT GMBH, MULTIPLE CLASS, (INT. CLS. 9 AND 42), (U.S. CLS. 21, 23, 26, 36, 38, 100 AND 101). SN 79-081,223. PUB. 1-18-2011. FILED 1-27-2010.
- 3,939,994. **SAFARI (STANDARD CHARACTER)**. STEINER-OPTIK GMBH, (U.S. CLS. 21, 23, 26, 36 AND 38). SN 79-081,417. PUB. 1-18-2011. FILED 2-2-2010.
- 3,939,998. **EASYTRAX (STANDARD CHARACTER)**. X-RITE EUROPE GMBH, MULTIPLE CLASS, (INT. CLS. 9 AND 16), (U.S. CLS. 2, 5, 21, 22, 23, 26, 29, 36, 37, 38 AND 50). SN 79-081,706. PUB. 1-18-2011. FILED 1-28-2010.
- 3,939,999 ( *See Class 6 for this trademark*).
- 3,940,003. **ZPDT (STANDARD CHARACTER)**. INTERNATIONAL BUSINESS MACHINES CORPORATION, MULTIPLE CLASS, (INT. CLS. 9, 16 AND 42), (U.S. CLS. 2, 5, 21, 22, 23, 26, 29, 36, 37, 38, 50, 100 AND 101). SN 79-081,854. PUB. 1-18-2011. FILED 3-23-2010.
- 3,940,004. **BOLING AND DESIGN**. FUZHOU BOLING PHOTOGRAPHIC EQUIPMENT CO., LTD., (U.S. CLS. 21, 23, 26, 36 AND 38). SN 79-081,863. PUB. 1-18-2011. FILED 4-6-2010.
- 3,940,013. **RAIKKO (STANDARD CHARACTER)**. BRS CONNECT MEDIEN- UND SYSTEMTECHNIK GMBH, (U.S. CLS. 21, 23, 26, 36 AND 38). SN 79-082,679. PUB. 1-18-2011. FILED 3-15-2010.
- 3,940,019 ( *See Class 7 for this trademark*).
- 3,940,021. **LITTLE JOHNNY (STANDARD CHARACTER)**. THE LITTLE JOHNNY TRADING COMPANY; PTY LTD, MULTIPLE CLASS, (INT. CLS. 9, 16, 25, 28 AND 41), (U.S. CLS. 2, 5, 21, 22, 23, 26, 29, 36, 37, 38, 39, 50, 100, 101 AND 107). SN 79-083,174. PUB. 1-18-2011. FILED 4-15-2010.
- 3,940,029 ( *See Class 3 for this trademark*).
- 3,940,033 ( *See Class 5 for this trademark*).
- 3,940,034. **CYBOZU AND DESIGN**. CYBOZU, INC., MULTIPLE CLASS, (INT. CLS. 9 AND 42), (U.S. CLS. 21, 23, 26, 36, 38, 100 AND 101). SN 79-084,651. PUB. 1-18-2011. FILED 3-4-2010.
- 3,940,040 ( *See Class 3 for this trademark*).
- 3,940,052. **QUATTROFLEX (STYLIZED)**. ALPINA SPORTS GMBH, (U.S. CLS. 21, 23, 26, 36 AND 38). SN 79-085,654. PUB. 1-18-2011. FILED 5-25-2010.
- 3,940,056. **HINKLER (STANDARD CHARACTER)**. HINKLER BOOKS PTY LTD, MULTIPLE CLASS, (INT. CLS. 9, 16, 28, 35 AND 41), (U.S. CLS. 2, 5, 21, 22, 23, 26, 29, 36, 37, 38, 50, 100, 101, 102 AND 107). SN 79-086,180. PUB. 1-18-2011. FILED 6-8-2010.
- 3,940,061 ( *See Class 7 for this trademark*).
- 3,940,062 ( *See Class 7 for this trademark*).
- 3,940,077. **CLIMACHECK (STANDARD CHARACTER)**. CLIMACHECK SWEDEN AB, MULTIPLE CLASS, (INT. CLS. 9 AND 38), (U.S. CLS. 21, 23, 26, 36, 38, 100, 101 AND 104). SN 79-089,058. PUB. 1-18-2011. FILED 6-22-2010.
- 3,940,086. **UFSWEEPER (STANDARD CHARACTER)**. SHIMADZU CORPORATION, (U.S. CLS. 21, 23, 26, 36 AND

- 38). SN 85-004,837. PUB. 1-18-2011. FILED 4-2-2010.
- 3,940,091. **UNLEASH THE SECRETS OF THE DEEP (STANDARD CHARACTER)**. WAYPOINT TECHNOLOGIES, INC., DBA LAKEMASTER LAKE MAPS, MULTIPLE CLASS, (INT. CLS. 9 AND 16), (U.S. CLS. 2, 5, 21, 22, 23, 26, 29, 36, 37, 38 AND 50). SN 85-006,103. PUB. 1-18-2011. FILED 4-5-2010.
- 3,940,094. **DERAM (STANDARD CHARACTER)**. DECCA MUSIC GROUP LIMITED, (U.S. CLS. 21, 23, 26, 36 AND 38). SN 85-007,739. PUB. 1-18-2011. FILED 4-6-2010.
- 3,940,109. **REFINED KNOWLEDGE (STANDARD CHARACTER)**. NALCO COMPANY, MULTIPLE CLASS, (INT. CLS. 9 AND 35), (U.S. CLS. 21, 23, 26, 36, 38, 100, 101 AND 102). SN 85-014,976. PUB. 1-18-2011. FILED 4-15-2010.
- 3,940,122. **HEARIT MOBILE (STANDARD CHARACTER)**. PHONIC EAR A/S, (U.S. CLS. 21, 23, 26, 36 AND 38). SN 85-021,512. PUB. 1-18-2011. FILED 4-23-2010.
- 3,940,123. **LESSON POP! AND DESIGN**. LESSONPOP, INC, AKA LESSONPOP.COM, (U.S. CLS. 21, 23, 26, 36 AND 38). SN 85-022,392. PUB. 1-18-2011. FILED 4-24-2010.
- 3,940,124. **W WATERBEAT AND DESIGN**. CREANOVATIVE INC., (U.S. CLS. 21, 23, 26, 36 AND 38). SN 85-022,643. PUB. 1-18-2011. FILED 4-25-2010.
- 3,940,130. **SEVEN45 STUDIOS (STANDARD CHARACTER)**. 745 LLC, (U.S. CLS. 21, 23, 26, 36 AND 38). SN 85-025,955. PUB. 1-18-2011. FILED 4-29-2010.
- 3,940,131. **POWER GIG AND DESIGN**. 745 LLC, MULTIPLE CLASS, (INT. CLS. 9 AND 15), (U.S. CLS. 2, 21, 23, 26, 36 AND 38). SN 85-026,272. PUB. 1-18-2011. FILED 4-29-2010.
- 3,940,133. **DIGITALMUNCH (STANDARD CHARACTER)**. DIGITALMUNCH LLC, (U.S. CLS. 21, 23, 26, 36 AND 38). SN 85-028,093. PUB. 1-18-2011. FILED 5-1-2010.
- 3,940,148. **MISCELLANEOUS DESIGN**. PRODUBAN SERVICIOS INFORMATICOS GENERALES, S.L., MULTIPLE CLASS, (INT. CLS. 9, 35, 36, 38 AND 42), (U.S. CLS. 21, 23, 26, 36, 38, 100, 101, 102 AND 104). SN 85-032,575. PUB. 1-18-2011. FILED 5-7-2010.
- 3,940,158. **QUANTUMLOGIC (STANDARD CHARACTER)**. HARMAN INTERNATIONAL INDUSTRIES, INCORPORATED, (U.S. CLS. 21, 23, 26, 36 AND 38). SN 85-035,797. PUB. 1-18-2011. FILED 5-11-2010.
- 3,940,168. **EAGLE STRIKE (STANDARD CHARACTER)**. ARISTOCRAT TECHNOLOGIES AUSTRALIA PTY LTD., (U.S. CLS. 21, 23, 26, 36 AND 38). SN 85-040,023. PUB. 1-18-2011. FILED 5-17-2010.
- 3,940,169. **HIDDEN REEF (STANDARD CHARACTER)**. ARISTOCRAT TECHNOLOGIES AUSTRALIA PTY LTD., (U.S. CLS. 21, 23, 26, 36 AND 38). SN 85-040,068. PUB. 1-18-2011. FILED 5-17-2010.
- 3,940,170. **HOUSEPARTY (STANDARD CHARACTER)**. DISRUPTIVE LIMITED, (U.S. CLS. 21, 23, 26, 36 AND 38). SN 85-040,135. PUB. 1-18-2011. FILED 5-17-2010.
- 3,940,188. **HOME WIRELESS MADE EASY (STANDARD CHARACTER)**. CISCO TECHNOLOGY, INC., (U.S. CLS. 21, 23, 26, 36 AND 38). SN 85-045,564. PUB. 1-18-2011. FILED 5-21-2010.
- 3,940,192. **BITCLEAN (STANDARD CHARACTER)**. RAVE LLC, (U.S. CLS. 21, 23, 26, 36 AND 38). SN 85-046,379. PUB. 1-18-2011. FILED 5-24-2010.
- 3,940,201. **INKLING (STANDARD CHARACTER)**. STANDARD NINE INC., DBA INKLING, MULTIPLE CLASS, (INT. CLS. 9 AND 42), (U.S. CLS. 21, 23, 26, 36, 38, 100 AND 101). SN 85-049,393. PUB. 1-18-2011. FILED 5-27-2010.
- 3,940,202. **INKLING (STYLIZED)**. STANDARD NINE INC., DBA INKLING, MULTIPLE CLASS, (INT. CLS. 9 AND 42), (U.S. CLS. 21, 23, 26, 36, 38, 100 AND 101). SN 85-049,408. PUB. 1-18-2011. FILED 5-27-2010.
- 3,940,221. **DGIS (STANDARD CHARACTER)**. AMERICAN LABELMARK COMPANY, MULTIPLE CLASS, (INT. CLS. 9 AND 35), (U.S. CLS. 21, 23, 26, 36, 38, 100, 101 AND 102). SN 85-056,185. PUB. 1-18-2011. FILED 6-7-2010.
- 3,940,228 ( *See Class 6 for this trademark*).
- 3,940,233. **LP CAPITAL ADVISORS (STANDARD CHARACTER)**. LP CAPITAL ADVISORS, LLC, MULTIPLE CLASS, (INT. CLS. 9 AND 36), (U.S. CLS. 21, 23, 26, 36, 38, 100, 101 AND 102). SN 85-059,217. PUB. 1-18-2011. FILED 6-10-2010.
- 3,940,247. **FILMSTAR (STANDARD CHARACTER)**. WALDE, INC., DBA WALDE, INC., (U.S. CLS. 21, 23, 26, 36 AND 38). SN 85-064,116. PUB. 1-18-2011. FILED 6-16-2010.
- 3,940,248. **THE OTHER SIDE OF SILENCE (STANDARD CHARACTER)**. NATASHA MOSTERT, MULTIPLE CLASS, (INT. CLS. 9, 16 AND 41), (U.S. CLS. 2, 5, 21, 22, 23, 26, 29, 36, 37, 38, 50, 100, 101 AND 107). SN 85-064,528. PUB. 1-18-2011. FILED 6-16-2010.
- 3,940,249. **WINDWALKER (STANDARD CHARACTER)**. NATASHA MOSTERT, MULTIPLE CLASS, (INT. CLS. 9, 16 AND 41), (U.S. CLS. 2, 5, 21, 22, 23, 26, 29, 36, 37, 38, 50, 100, 101 AND 107). SN 85-064,556. PUB. 1-18-2011. FILED 6-16-2010.
- 3,940,250. **THE MIDNIGHT SIDE (STANDARD CHARACTER)**. NATASHA MOSTERT, MULTIPLE CLASS, (INT. CLS. 9, 16 AND 41), (U.S. CLS. 2, 5, 21, 22, 23, 26, 29, 36, 37, 38, 50, 100, 101 AND 107). SN 85-064,592. PUB. 1-18-2011. FILED 6-16-2010.
- 3,940,251. **KEEPER OF LIGHT AND DUST (STANDARD CHARACTER)**. NATASHA MOSTERT, MULTIPLE CLASS, (INT. CLS. 9, 16 AND 41), (U.S. CLS. 2, 5, 21, 22, 23, 26, 29, 36, 37, 38, 50, 100, 101 AND 107). SN 85-064,623. PUB. 1-18-2011. FILED 6-16-2010.
- 3,940,252. **THE KEEPER (STANDARD CHARACTER)**. NATASHA MOSTERT, MULTIPLE CLASS, (INT. CLS. 9, 16 AND 41), (U.S. CLS. 2, 5, 21, 22, 23, 26, 29, 36, 37, 38, 50, 100, 101 AND 107). SN 85-064,634. PUB. 1-18-2011. FILED 6-16-2010.
- 3,940,265. **BODYGUARD (STANDARD CHARACTER)**. FASTENAL IP COMPANY, MULTIPLE CLASS, (INT. CLS. 9, 21, 25 AND 26), (U.S. CLS. 2, 13, 21, 22, 23, 26, 29, 30, 33, 36, 37, 38, 39, 40, 42 AND 50). SN 85-068,434. PUB. 1-18-2011. FILED 6-22-2010.
- 3,940,268. **BRAEBURN (STANDARD CHARACTER)**. BRAEBURN SYSTEMS LLC, MULTIPLE CLASS, (INT. CLS. 9 AND 11), (U.S. CLS. 13, 21, 23, 26, 31, 34, 36 AND 38). SN 85-069,326. PUB. 1-18-2011. FILED 6-23-2010.
- 3,940,276. **GRIDCAST (STANDARD CHARACTER)**. RUS-SOUND/FMP, INC., (U.S. CLS. 21, 23, 26, 36 AND 38). SN 85-070,574. PUB. 1-18-2011. FILED 6-24-2010.
- 3,940,283. **CLEAN CANDY PUSH AND DESIGN**. CLEANCANDY SWEDEN AKTIEBOLAG, MULTIPLE CLASS, (INT. CLS. 9, 21 AND 30), (U.S. CLS. 2, 13, 21, 23, 26, 29, 30, 33, 36, 38, 40, 46 AND 50). SN 85-072,750. PUB. 1-18-2011. FILED 6-28-2010.
- 3,940,291. **MISCELLANEOUS DESIGN**. JIANGSU EVERSO-LAR NEW ENERGY CO., LTD., (U.S. CLS. 21, 23, 26, 36 AND 38). SN 85-075,612. PUB. 1-18-2011. FILED 7-1-2010.
- 3,940,293. **THOR POWER (STANDARD CHARACTER)**. THOR POWER CORPORATION, (U.S. CLS. 21, 23, 26, 36 AND 38). SN 85-076,299. PUB. 1-18-2011. FILED 7-1-2010.
- 3,940,298. **STEREO REALIST AND DESIGN**. JOHN J. ZELENKA, DBA STEREO REALIST, (U.S. CLS. 21, 23, 26, 36 AND 38). SN 85-078,452. PUB. 1-18-2011. FILED 7-6-2010.
- 3,940,318. **M, K, MCKENNEY'S INC. AND DESIGN**. MCKENNEY'S, INC., MULTIPLE CLASS, (INT. CLS. 9, 11, 37 AND 42), (U.S. CLS. 13, 21, 23, 26, 31, 34, 36, 38, 100, 101, 103 AND 106). SN 85-082,217. PUB. 1-18-2011. FILED 7-12-2010.
- 3,940,319. **ODOYO AND DESIGN**. THINKING GROUP LIMITED, (U.S. CLS. 21, 23, 26, 36 AND 38). SN 85-082,418. PUB. 1-18-2011. FILED 7-12-2010.
- 3,940,330. **Z ALIGN (STANDARD CHARACTER)**. CARL ZEISS AG, (U.S. CLS. 21, 23, 26, 36 AND 38). SN 85-084,532. PUB. 1-18-2011. FILED 7-14-2010.
- 3,940,357. **DAZL! (STANDARD CHARACTER)**. MICROSEMI CORPORATION, (U.S. CLS. 21, 23, 26, 36 AND 38). SN 85-088,755. PUB. 1-18-2011. FILED 7-20-2010.
- 3,940,360. **CLZ (STANDARD CHARACTER)**. BITZ & PIXELZ BV, (U.S. CLS. 21, 23, 26, 36 AND 38). SN 85-089,165. PUB. 1-18-2011. FILED 7-21-2010.
- 3,940,361. **ONSET AND DESIGN**. INCA DIGITAL PRINTERS LIMITED, (U.S. CLS. 21, 23, 26, 36 AND 38). SN 85-089,393. PUB. 1-18-2011. FILED 7-21-2010.
- 3,940,366. **BIBLE.IS (STANDARD CHARACTER)**. HOSANNA, DBA FAITH COMES BY HEARING, (U.S. CLS. 21, 23, 26, 36 AND 38). SN 85-090,406. PUB. 1-18-2011. FILED 7-22-2010.
- 3,940,370. **EMS-ALERT (STANDARD CHARACTER)**. FLA-SHEALTH, LLC, (U.S. CLS. 21, 23, 26, 36 AND 38). SN 85-091,162. PUB. 1-18-2011. FILED 7-22-2010.
- 3,940,371. **24 TWO FOUR ONE (STYLIZED)**. ALEXANDER, RIC R, (U.S. CLS. 21, 23, 26, 36 AND 38). SN 85-091,252. PUB.

- 1-18-2011. FILED 7-23-2010.
- 3,940,395. **THE PHOENIX TRACKER (STANDARD CHARACTER)**. WINDTRAC LTD., DBA WINDTRAC GPS, (U.S. CLS. 21, 23, 26, 36 AND 38). SN 85-093,732. PUB. 1-18-2011. FILED 7-27-2010.
- 3,940,414. **BARTAB AND DESIGN**. WEBTAB, MULTIPLE CLASS, (INT. CLS. 9 AND 42), (U.S. CLS. 21, 23, 26, 36, 38, 100 AND 101). SN 85-095,411. PUB. 1-18-2011. FILED 7-28-2010.
- 3,940,416. **SIRUI AND DESIGN**. ZHONGSHAN SIRUI PHOTOGRAPHIC EQUIPMENT INDUSTRY CO., LTD., (U.S. CLS. 21, 23, 26, 36 AND 38). SN 85-095,476. PUB. 1-18-2011. FILED 7-29-2010.
- 3,940,425. **GEM-VALVE (STANDARD CHARACTER)**. GEOSERVICES EQUIPEMENTS, MULTIPLE CLASS, (INT. CLS. 9 AND 37), (U.S. CLS. 21, 23, 26, 36, 38, 100, 103 AND 106). SN 85-096,032. PUB. 1-18-2011. FILED 7-29-2010.
- 3,940,432. **CYCLE-MATE (STANDARD CHARACTER)**. URBAN PUBLICATIONS INC, (U.S. CLS. 21, 23, 26, 36 AND 38). SN 85-096,365. PUB. 1-18-2011. FILED 7-29-2010.
- 3,940,442. **GPCM (STANDARD CHARACTER)**. RT7K, LLC, MULTIPLE CLASS, (INT. CLS. 9 AND 42), (U.S. CLS. 21, 23, 26, 36, 38, 100 AND 101). SN 85-096,728. PUB. 1-18-2011. FILED 7-30-2010.
- 3,940,447. **KINNEY (STANDARD CHARACTER)**. TERMINAL DESIGN, INC., (U.S. CLS. 21, 23, 26, 36 AND 38). SN 85-096,857. PUB. 1-18-2011. FILED 7-30-2010.
- 3,940,450. **MICRO DRAW (STANDARD CHARACTER)**. XENTRIS WIRELESS, LLC, (U.S. CLS. 21, 23, 26, 36 AND 38). SN 85-096,896. PUB. 1-18-2011. FILED 7-30-2010.
- 3,940,473. **AGE OF CHAMPIONS (STANDARD CHARACTER)**. KLICKNATION CORPORATION, MULTIPLE CLASS, (INT. CLS. 9 AND 41), (U.S. CLS. 21, 23, 26, 36, 38, 100, 101 AND 107). SN 85-097,431. PUB. 1-18-2011. FILED 7-30-2010.
- 3,940,482. **DR LEAF SWITCH ON YOUR BRAIN AND DESIGN**. SWOYB PROPERTIES, LP, (U.S. CLS. 21, 23, 26, 36 AND 38). SN 85-097,499. PUB. 1-18-2011. FILED 7-31-2010.
- 3,940,485. **TRUVIEW (STANDARD CHARACTER)**. GUILHERME CARDOSO DE CARDOSO, AKA BILL CARDOSO, (U.S. CLS. 21, 23, 26, 36 AND 38). SN 85-097,561. PUB. 1-18-2011. FILED 7-31-2010.
- 3,940,487. **TRUVIEW NANO (STANDARD CHARACTER)**. GUILHERME CARDOSO DE CARDOSO, AKA BILL CARDOSO, (U.S. CLS. 21, 23, 26, 36 AND 38). SN 85-097,564. PUB. 1-18-2011. FILED 7-31-2010.
- 3,940,491. **IRAD (STANDARD CHARACTER)**. GUILHERME CARDOSO DE CARDOSO, AKA BILL CARDOSO, (U.S. CLS. 21, 23, 26, 36 AND 38). SN 85-097,612. PUB. 1-18-2011. FILED 8-1-2010.
- 3,940,492. **VBACKUP (STANDARD CHARACTER)**. THINWARE, INC., (U.S. CLS. 21, 23, 26, 36 AND 38). SN 85-097,620. PUB. 1-18-2011. FILED 8-1-2010.
- 3,940,509. **EPICENTER (STANDARD CHARACTER)**. TYNDALE HOUSE PUBLISHERS, INC., MULTIPLE CLASS, (INT. CLS. 9 AND 41), (U.S. CLS. 21, 23, 26, 36, 38, 100, 101 AND 107). SN 85-097,868. PUB. 1-18-2011. FILED 8-2-2010.
- 3,940,559. **DILIGENCE AND DESIGN**. PRECISE, INC., (U.S. CLS. 21, 23, 26, 36 AND 38). SN 85-098,738. PUB. 1-18-2011. FILED 8-3-2010.
- 3,940,582. **COX INSTRUMENTS (STANDARD CHARACTER)**. BADGER METER, INC., (U.S. CLS. 21, 23, 26, 36 AND 38). SN 85-099,169. PUB. 1-18-2011. FILED 8-3-2010.
- 3,940,617. **FIRST SIGHT AND DESIGN**. GREGORY A. MAHLOCH, (U.S. CLS. 21, 23, 26, 36 AND 38). SN 85-099,774. PUB. 1-18-2011. FILED 8-4-2010.
- 3,940,629. **CAMRY (STYLIZED)**. ZHONG SHAN CAMRY ELECTRONICS CO., LTD., (U.S. CLS. 21, 23, 26, 36 AND 38). SN 85-099,957. PUB. 1-18-2011. FILED 8-4-2010.
- 3,940,632. **CALENDAR OF WOODEN BOATS (STANDARD CHARACTER)**. MENDLOWITZ, BENJAMIN, DBA NOAH PUBLICATIONS, MULTIPLE CLASS, (INT. CLS. 9 AND 16), (U.S. CLS. 2, 5, 21, 22, 23, 26, 29, 36, 37, 38 AND 50). SN 85-099,964. PUB. 1-18-2011. FILED 8-4-2010.
- 3,940,633. **VAMPS (STANDARD CHARACTER)**. BROOKER, ERIC, (U.S. CLS. 21, 23, 26, 36 AND 38). SN 85-099,966. PUB. 1-18-2011. FILED 8-4-2010.
- 3,940,647. **MCOMI (STANDARD CHARACTER)**. MJ SALES, INC., (U.S. CLS. 21, 23, 26, 36 AND 38). SN 85-100,155. PUB. 1-18-2011. FILED 8-4-2010.
- 3,940,657. **SCALLOP IMAGING (STANDARD CHARACTER)**. TENEBRAEX CORPORATION, (U.S. CLS. 21, 23, 26, 36 AND 38). SN 85-100,253. PUB. 1-18-2011. FILED 8-4-2010.
- 3,940,678. **RENTPLUS (STANDARD CHARACTER)**. HI-TECH SMART SYSTEMS, INC., FORMERLY HI-TECH LEASING, INC., (U.S. CLS. 21, 23, 26, 36 AND 38). SN 85-100,537. PUB. 1-18-2011. FILED 8-4-2010.
- 3,940,690. **MYPARTSHELP.COM (STANDARD CHARACTER)**. SERVICE COMPANY SOLUTIONS, LLC, (U.S. CLS. 21, 23, 26, 36 AND 38). SN 85-100,721. PUB. 1-18-2011. FILED 8-5-2010.
- 3,940,761. **SILVER SASH (STANDARD CHARACTER)**. CALICUT SOFTWARE, INC., (U.S. CLS. 21, 23, 26, 36 AND 38). SN 85-101,604. PUB. 1-18-2011. FILED 8-6-2010.
- 3,940,775. **EL DORADO (STANDARD CHARACTER)**. CELL CITY CO., (U.S. CLS. 21, 23, 26, 36 AND 38). SN 85-101,947. PUB. 1-18-2011. FILED 8-6-2010.
- 3,940,798. **MISCELLANEOUS DESIGN**. DISTEK INTEGRATION, INC., MULTIPLE CLASS, (INT. CLS. 9 AND 42), (U.S. CLS. 21, 23, 26, 36, 38, 100 AND 101). SN 85-102,312. PUB. 1-18-2011. FILED 8-6-2010.
- 3,940,816. **WENTZSCOPE (STANDARD CHARACTER)**. WENTZ, JOHN BUDD, III, DBA BUDD WENTZ PRODUCTIONS, (U.S. CLS. 21, 23, 26, 36 AND 38). SN 85-102,512. PUB. 1-18-2011. FILED 8-7-2010.
- 3,940,826. **ZKZ (STYLIZED)**. ZKZ BEST POWER INC., (U.S. CLS. 21, 23, 26, 36 AND 38). SN 85-102,572. PUB. 1-18-2011. FILED 8-7-2010.
- 3,940,834. **THUG FINDIR (STANDARD CHARACTER)**. INTEGRATED TECHNOLOGY SYSTEMS, INC., (U.S. CLS. 21, 23, 26, 36 AND 38). SN 85-102,714. PUB. 1-18-2011. FILED 8-8-2010.
- 3,940,835. **THUG FINDIR AND DESIGN**. INTEGRATED TECHNOLOGY SYSTEMS, INC., (U.S. CLS. 21, 23, 26, 36 AND 38). SN 85-102,718. PUB. 1-18-2011. FILED 8-8-2010.
- 3,940,841. **SYSSNAP (STANDARD CHARACTER)**. SYSTREAM, LLC, DBA SYSTREAM, LLC, (U.S. CLS. 21, 23, 26, 36 AND 38). SN 85-103,346. PUB. 1-18-2011. FILED 8-9-2010.
- 3,940,915. **PROTECT YOUR CLOUD (STANDARD CHARACTER)**. THINWARE, INC., (U.S. CLS. 21, 23, 26, 36 AND 38). SN 85-118,185. PUB. 1-18-2011. FILED 8-29-2010.
- 3,940,937. **FLOURISH (STANDARD CHARACTER)**. BALL HORTICULTURAL COMPANY, MULTIPLE CLASS, (INT. CLS. 9 AND 16), (U.S. CLS. 2, 5, 21, 22, 23, 26, 29, 36, 37, 38 AND 50). SN 85-128,183. PUB. 1-18-2011. FILED 9-13-2010.
- 3,940,949. **CTC (STANDARD CHARACTER)**. CONAIR CORPORATION, MULTIPLE CLASS, (INT. CLS. 9, 11 AND 21), (U.S. CLS. 2, 13, 21, 23, 26, 29, 30, 31, 33, 34, 36, 38, 40 AND 50). SN 85-136,418. PUB. 1-18-2011. FILED 9-23-2010.
- 3,940,951. **DREAM CARD (STANDARD CHARACTER)**. IGT, (U.S. CLS. 21, 23, 26, 36 AND 38). SN 85-137,098. PUB. 1-18-2011. FILED 9-23-2010.
- 3,940,957. **REPTITEMP (STANDARD CHARACTER)**. ZOO MED LABORATORIES, INC., (U.S. CLS. 21, 23, 26, 36 AND 38). SN 85-140,967. PUB. 1-18-2011. FILED 9-29-2010.

---

## CLASS 10—MEDICAL APPARATUS

- 3,939,440. **SUPERCUT (STANDARD CHARACTER)**. KARL STORZ GMBH & CO. KG, MULTIPLE CLASS, (INT. CLS. 10 AND 16), (U.S. CLS. 2, 5, 22, 23, 26, 29, 37, 38, 39, 44 AND 50). SN 77-624,378. PUB. 6-9-2009. FILED 12-2-2008.
- 3,939,482. **POWER LIFTER (STANDARD CHARACTER)**. OMNI ACQUISITION CORP., DBA OMNIMED, INC., (U.S. CLS. 26, 39 AND 44). SN 77-742,857. PUB. 1-18-2011. FILED 5-22-2009.
- 3,939,489. **SLIMLINE (STANDARD CHARACTER)**. RESMED LIMITED, (U.S. CLS. 26, 39 AND 44). SN 77-752,381. PUB. 1-18-2011. FILED 6-4-2009.
- 3,939,608. **LOVE LOVECONDOMS.ORG AND DESIGN**. AIDS HEALTHCARE FOUNDATION, (U.S. CLS. 26, 39 AND 44). SN 77-899,680. PUB. 1-18-2011. FILED 12-22-2009.
- 3,939,696. **INNER BALANCE (STANDARD CHARACTER)**.

- JOHNSON HEALTH TECH NORTH AMERICA, INC., (U.S. CLS. 26, 39 AND 44). SN 77-931,364. PUB. 1-18-2011. FILED 2-9-2010.
- 3,939,697. **OIS EYESCAN (STANDARD CHARACTER)**. OPHTHALMIC IMAGING SYSTEMS, (U.S. CLS. 26, 39 AND 44). SN 77-931,574. PUB. 1-18-2011. FILED 2-9-2010.
- 3,939,881 ( *See Class 1 for this trademark*).
- 3,939,893 ( *See Class 5 for this trademark*).
- 3,939,907 ( *See Class 5 for this trademark*).
- 3,939,963 ( *See Class 5 for this trademark*).
- 3,940,007. **C5 (STANDARD CHARACTER)**. SORIN GROUP ITALIA S.R.L., (U.S. CLS. 26, 39 AND 44). SN 79-082,224. PUB. 1-18-2011. FILED 3-17-2010.
- 3,940,019 ( *See Class 7 for this trademark*).
- 3,940,030 ( *See Class 5 for this trademark*).
- 3,940,033 ( *See Class 5 for this trademark*).
- 3,940,070. **MEMOCAP (STANDARD CHARACTER)**. NOVO NORDISK A/S, (U.S. CLS. 26, 39 AND 44). SN 79-087,844. PUB. 1-18-2011. FILED 8-16-2010.
- 3,940,197. **ALPHATEC SPINE (STANDARD CHARACTER)**. ALPHATEC SPINE, INC., MULTIPLE CLASS, (INT. CLS. 10, 35, 40 AND 42), (U.S. CLS. 26, 39, 44, 100, 101, 102, 103 AND 106). SN 85-048,003. PUB. 1-18-2011. FILED 5-26-2010.
- 3,940,260. **TAKING THE STING OUT OF SHOTS! (STANDARD CHARACTER)**. MMJ LABS, LLC, (U.S. CLS. 26, 39 AND 44). SN 85-065,960. PUB. 1-18-2011. FILED 6-17-2010.
- 3,940,286 ( *See Class 5 for this trademark*).
- 3,940,315. **COLDTUB AND DESIGN**. SPA LOGIC INC., (U.S. CLS. 26, 39 AND 44). SN 85-081,757. PUB. 1-18-2011. FILED 7-9-2010.
- 3,940,350. **SNAPPY (STANDARD CHARACTER)**. WEISBLATT, KRIS, (U.S. CLS. 26, 39 AND 44). SN 85-088,069. PUB. 1-18-2011. FILED 7-19-2010.
- 3,940,520. **U-WINDIT (STANDARD CHARACTER)**. DEVINE, JAMES D., DBA U-WINDIT, (U.S. CLS. 26, 39 AND 44). SN 85-098,096. PUB. 1-18-2011. FILED 8-2-2010.
- 3,940,684. **RED-LINE AND DESIGN**. REDLINE PRODUCTS PTY LTD, (U.S. CLS. 26, 39 AND 44). SN 85-100,602. PUB. 1-18-2011. FILED 8-5-2010.
- 3,940,738. **MANDINGO (STANDARD CHARACTER)**. GLOBAL FORCE ENTERPRISES LLC, (U.S. CLS. 26, 39 AND 44). SN 85-101,345. PUB. 1-18-2011. FILED 8-5-2010.
- 3,940,743. **UNISWAB (STYLIZED)**. APP-UNIPATH, LLC, AKA UNIPATH, (U.S. CLS. 26, 39 AND 44). SN 85-101,452. PUB. 1-18-2011. FILED 8-5-2010.
- 3,940,853. **SPINEDOK (STANDARD CHARACTER)**. ALTRUEON LLC, (U.S. CLS. 26, 39 AND 44). SN 85-103,487. PUB. 1-18-2011. FILED 8-9-2010.
- 3,940,870. **S STAHL ENDOSCOPY AND DESIGN**. S.H. MEDICAL CORPORATION, (U.S. CLS. 26, 39 AND 44). SN 85-107,068. PUB. 1-18-2011. FILED 8-13-2010.
- 3,940,904. **FOOBAG (STANDARD CHARACTER)**. LONIGRO, CRAIG SCOTT, (U.S. CLS. 26, 39 AND 44). SN 85-115,707. PUB. 1-18-2011. FILED 8-25-2010.
- 3,940,911. **VASCUTRAK (STANDARD CHARACTER)**. Y-MED, INC., (U.S. CLS. 26, 39 AND 44). SN 85-117,217. PUB. 1-18-2011. FILED 8-27-2010.
- 3,939,483. **MISCELLANEOUS DESIGN**. MODERNICA, INC., (U.S. CLS. 13, 21, 23, 31 AND 34). SN 77-748,146. PUB. 1-18-2011. FILED 5-29-2009.
- 3,939,484. **MISCELLANEOUS DESIGN**. MODERNICA, INC., (U.S. CLS. 13, 21, 23, 31 AND 34). SN 77-748,149. PUB. 1-18-2011. FILED 5-29-2009.
- 3,939,490 ( *See Class 6 for this trademark*).
- 3,939,509 ( *See Class 7 for this trademark*).
- 3,939,562 ( *See Class 4 for this trademark*).
- 3,939,564. **THE COMFORT PEOPLE SINCE 1962 (STANDARD CHARACTER)**. CONDITIONED AIR CORPORATION OF NAPLES, INC., MULTIPLE CLASS, (INT. CLS. 11 AND 37), (U.S. CLS. 13, 21, 23, 31, 34, 100, 103 AND 106). SN 77-852,733. PUB. 1-18-2011. FILED 10-20-2009.
- 3,939,814. **WICKED BAGGER (STANDARD CHARACTER)**. WICKED BAGGER LLC, (U.S. CLS. 13, 21, 23, 31 AND 34). SN 77-958,295. PUB. 1-18-2011. FILED 3-13-2010.
- 3,939,830. **FLOWDECOR (STANDARD CHARACTER)**. FLOWDECOR INC., MULTIPLE CLASS, (INT. CLS. 11 AND 20), (U.S. CLS. 2, 13, 21, 22, 23, 25, 31, 32, 34 AND 50). SN 77-962,483. PUB. 1-18-2011. FILED 3-18-2010.
- 3,939,888 ( *See Class 7 for this trademark*).
- 3,939,903 ( *See Class 8 for this trademark*).
- 3,939,912 ( *See Class 7 for this trademark*).
- 3,939,914 ( *See Class 9 for this trademark*).
- 3,939,937. **SEAPRO (STANDARD CHARACTER)**. DEGREMONT, MULTIPLE CLASS, (INT. CLS. 11, 40 AND 42), (U.S. CLS. 13, 21, 23, 31, 34, 100, 101, 103 AND 106). SN 79-078,441. PUB. 1-18-2011. FILED 12-16-2009.
- 3,939,938. **ULTRAMARINE (STANDARD CHARACTER)**. DEGREMONT, MULTIPLE CLASS, (INT. CLS. 11, 40 AND 42), (U.S. CLS. 13, 21, 23, 31, 34, 100, 101, 103 AND 106). SN 79-078,442. PUB. 1-18-2011. FILED 12-16-2009.
- 3,939,944. **ULTRABLUE (STANDARD CHARACTER)**. DEGREMONT, MULTIPLE CLASS, (INT. CLS. 11, 40 AND 42), (U.S. CLS. 13, 21, 23, 31, 34, 100, 101, 103 AND 106). SN 79-079,235. PUB. 1-18-2011. FILED 12-16-2009.
- 3,939,945. **SMARTRACK (STANDARD CHARACTER)**. DEGREMONT, MULTIPLE CLASS, (INT. CLS. 11, 40 AND 42), (U.S. CLS. 13, 21, 23, 31, 34, 100, 101, 103 AND 106). SN 79-079,335. PUB. 1-18-2011. FILED 12-16-2009.
- 3,939,946. **ULTRAGREEN (STANDARD CHARACTER)**. DEGREMONT, MULTIPLE CLASS, (INT. CLS. 11, 40 AND 42), (U.S. CLS. 13, 21, 23, 31, 34, 100, 101, 103 AND 106). SN 79-079,366. PUB. 1-18-2011. FILED 12-15-2009.
- 3,939,949 ( *See Class 7 for this trademark*).
- 3,939,979 ( *See Class 9 for this trademark*).
- 3,939,983. **GROHE ENHANCEDWATER (STANDARD CHARACTER)**. GROHE AG, MULTIPLE CLASS, (INT. CLS. 11, 20 AND 21), (U.S. CLS. 2, 13, 21, 22, 23, 25, 29, 30, 31, 32, 33, 34, 40 AND 50). SN 79-081,112. PUB. 1-18-2011. FILED 2-4-2010.
- 3,939,986. **AQUAENGINE (STANDARD CHARACTER)**. GROHE AG, MULTIPLE CLASS, (INT. CLS. 11, 20 AND 21), (U.S. CLS. 2, 13, 21, 22, 23, 25, 29, 30, 31, 32, 33, 34, 40 AND 50). SN 79-081,204. PUB. 1-18-2011. FILED 2-18-2010.
- 3,939,987. **GROHE AQUA DIVERTER (STANDARD CHARACTER)**. GROHE AG, MULTIPLE CLASS, (INT. CLS. 11, 20 AND 21), (U.S. CLS. 2, 13, 21, 22, 23, 25, 29, 30, 31, 32, 33, 34, 40 AND 50). SN 79-081,207. PUB. 1-18-2011. FILED 2-18-2010.
- 3,939,988 ( *See Class 7 for this trademark*).
- 3,940,028. **GREEN VENTILATION AND DESIGN**. SYSTEMAIR AKTIEBOLAG, (U.S. CLS. 13, 21, 23, 31 AND 34). SN 79-084,122. PUB. 1-18-2011. FILED 3-18-2010.
- 3,940,054. **AEROSTRIP (STANDARD CHARACTER)**. AQUACONSULT ANLAGENBAU GES.M.B.H., MULTIPLE CLASS, (INT. CLS. 11, 37 AND 42), (U.S. CLS. 13, 21, 23, 31, 34, 100, 101, 103 AND 106). SN 79-085,872. PUB. 1-18-2011. FILED 3-11-2010.
- 3,940,057. **UPANG (STYLIZED)**. BLUE CARE CO.,LTD, (U.S. CLS. 13, 21, 23, 31 AND 34). SN 79-086,383. PUB. 1-18-2011. FILED 4-21-2010.
- 3,940,071. **MICRODYN-NADIR (STANDARD CHARACTER)**. MICRODYN-NADIR GMBH, (U.S. CLS. 13, 21, 23, 31 AND 34). SN 79-087,993. PUB. 1-18-2011. FILED 8-5-2010.
- 3,940,093 ( *See Class 7 for this trademark*).
- 3,940,104 ( *See Class 7 for this trademark*).
- 3,940,176. **TLIGHT (STYLIZED)**. M&C LIGHTING CO., LTD., (U.S. CLS. 13, 21, 23, 31 AND 34). SN 85-041,224. PUB. 1-18-

## CLASS 11—ENVIRONMENTAL CONTROL APPARATUS

2011. FILED 5-18-2010.  
 3,940,226. **KLIMAIRE AND DESIGN**. KLIMAIRE PRODUCTS INC., (U.S. CLS. 13, 21, 23, 31 AND 34). SN 85-057,195. PUB. 1-18-2011. FILED 6-8-2010.  
 3,940,268 ( *See Class 9 for this trademark*).  
 3,940,303. **MAHOGANY (STANDARD CHARACTER)**. NATIONAL STEELCRAFTERS OF TEXAS, LLC, (U.S. CLS. 13, 21, 23, 31 AND 34). SN 85-079,215. PUB. 1-18-2011. FILED 7-7-2010.  
 3,940,318 ( *See Class 9 for this trademark*).  
 3,940,358. **OSP (ON SITE PROGRAMMABLE) (STANDARD CHARACTER)**. SSB DESIGN, INC, DBA CYGOLITE, (U.S. CLS. 13, 21, 23, 31 AND 34). SN 85-088,814. PUB. 1-18-2011. FILED 7-20-2010.  
 3,940,536. **COMPASS (STANDARD CHARACTER)**. GEOCOMFORT, INC, (U.S. CLS. 13, 21, 23, 31 AND 34). SN 85-098,410. PUB. 1-18-2011. FILED 8-2-2010.  
 3,940,584. **CROSSFIRE (STANDARD CHARACTER)**. SCHOTT GEMTRON CORPORATION, (U.S. CLS. 13, 21, 23, 31 AND 34). SN 85-099,199. PUB. 1-18-2011. FILED 8-3-2010.  
 3,940,727. **AQUAOLGY (STANDARD CHARACTER)**. AERUS CONCEPTS, LP, (U.S. CLS. 13, 21, 23, 31 AND 34). SN 85-101,193. PUB. 1-18-2011. FILED 8-5-2010.  
 3,940,728. **SOLAGEO (STANDARD CHARACTER)**. FERNANDEZ, JOSEPH S., (U.S. CLS. 13, 21, 23, 31 AND 34). SN 85-101,230. PUB. 1-18-2011. FILED 8-5-2010.  
 3,940,749. **FRESH SIP (STANDARD CHARACTER)**. IBT CONSULTANTS INC., (U.S. CLS. 13, 21, 23, 31 AND 34). SN 85-101,497. PUB. 1-18-2011. FILED 8-5-2010.  
 3,940,771. **BAKER (STANDARD CHARACTER)**. BAKER, KNAPP & TUBBS, INC., MULTIPLE CLASS, (INT. CLS. 11, 21 AND 42), (U.S. CLS. 2, 13, 21, 23, 29, 30, 31, 33, 34, 40, 50, 100 AND 101). SN 85-101,864. PUB. 1-18-2011. FILED 8-6-2010.  
 3,940,885. **PROTECTOR TREATMENT SYSTEMS (STANDARD CHARACTER)**. ENVIRONMENTAL PRODUCTS OF MN, INC., (U.S. CLS. 13, 21, 23, 31 AND 34). SN 85-110,532. PUB. 1-18-2011. FILED 8-18-2010.  
 3,940,949 ( *See Class 9 for this trademark*).  
 3,940,966. **TETCO (STANDARD CHARACTER)**. ENERTECH MANUFACTURING, LLC, (U.S. CLS. 13, 21, 23, 31 AND 34). SN 85-151,707. PUB. 1-18-2011. FILED 10-13-2010.

---

## CLASS 12—VEHICLES

3,939,352. **PDW (STYLIZED)**. PORTLAND DESIGN WORKS, LLC, (U.S. CLS. 19, 21, 23, 31, 35 AND 44). SN 76-698,833. PUB. 1-18-2011. FILED 8-6-2009.  
 3,939,377. **SST SYSTEMS SYNERGY TECHNOLOGY (STYLIZED)**. FEDERATED AUTO PARTS DISTRIBUTORS, INC., (U.S. CLS. 19, 21, 23, 31, 35 AND 44). SN 76-703,480. PUB. 1-18-2011. FILED 6-22-2010.  
 3,939,390 ( *See Class 6 for this trademark*).  
 3,939,425. **TRACK-O (STANDARD CHARACTER)**. MOVEX INNOVATION INC., (U.S. CLS. 19, 21, 23, 31, 35 AND 44). SN 77-496,890. PUB. 1-18-2011. FILED 6-11-2008.  
 3,939,465. **WAKEBOOST (STANDARD CHARACTER)**. BOMBARDIER RECREATIONAL PRODUCTS INC., (U.S. CLS. 19, 21, 23, 31, 35 AND 44). SN 77-706,137. PUB. 1-18-2011. FILED 4-3-2009.  
 3,939,495. **KINERGY (STANDARD CHARACTER)**. HANKOOK TIRE CO., LTD., (U.S. CLS. 19, 21, 23, 31, 35 AND 44). SN 77-767,986. PUB. 1-18-2011. FILED 6-25-2009.  
 3,939,516 ( *See Class 9 for this trademark*).  
 3,939,565. **THE BEAST (STANDARD CHARACTER)**. GOLF CART WORLD, INC., (U.S. CLS. 19, 21, 23, 31, 35 AND 44). SN 77-852,889. PUB. 3-30-2010. FILED 10-20-2009.  
 3,939,601. **ROCKMEISTER (STANDARD CHARACTER)**. VOLGER, KARL, (U.S. CLS. 19, 21, 23, 31, 35 AND 44). SN 77-891,374. PUB. 1-18-2011. FILED 12-11-2009.  
 3,939,884. **PELAGIC AND DESIGN**. JAMES V NOVAK, (U.S. CLS. 19, 21, 23, 31, 35 AND 44). SN 79-061,075. PUB. 1-18-2011. FILED 6-26-2008.  
 3,939,888 ( *See Class 7 for this trademark*).  
 3,939,906 ( *See Class 7 for this trademark*).  
 3,939,933 ( *See Class 1 for this trademark*).

3,939,941. **TRIDEC AND DESIGN**. TRIDEC B.V., MULTIPLE CLASS, (INT. CLS. 12, 40 AND 42), (U.S. CLS. 19, 21, 23, 31, 35, 44, 100, 101, 103 AND 106). SN 79-078,936. PUB. 1-18-2011. FILED 12-9-2009.  
 3,939,954. **BUB (STYLIZED)**. BATAVUS B.V., MULTIPLE CLASS, (INT. CLS. 12, 14, 18 AND 25), (U.S. CLS. 1, 2, 3, 19, 21, 22, 23, 27, 28, 31, 35, 39, 41, 44 AND 50). SN 79-080,144. PUB. 1-18-2011. FILED 1-28-2010.  
 3,939,955. **MISCELLANEOUS DESIGN**. UNION CYCLISTE INTERNATIONALE, MULTIPLE CLASS, (INT. CLS. 12, 25 AND 41), (U.S. CLS. 19, 21, 22, 23, 31, 35, 39, 44, 100, 101 AND 107). SN 79-080,237. PUB. 1-18-2011. FILED 2-18-2010.  
 3,940,002. **BUB (STANDARD CHARACTER)**. BATAVUS B.V., MULTIPLE CLASS, (INT. CLS. 12, 14, 18 AND 25), (U.S. CLS. 1, 2, 3, 19, 21, 22, 23, 27, 28, 31, 35, 39, 41, 44 AND 50). SN 79-081,852. PUB. 1-18-2011. FILED 12-9-2009.  
 3,940,031. **VANMOOF (STANDARD CHARACTER)**. VANMOOF B.V., (U.S. CLS. 19, 21, 23, 31, 35 AND 44). SN 79-084,437. PUB. 1-18-2011. FILED 11-11-2009.  
 3,940,055 ( *See Class 7 for this trademark*).  
 3,940,066. **COMPACTIVE (STANDARD CHARACTER)**. BAYERISCHE MOTOREN WERKE AKTIENGESELLSCHAFT, (U.S. CLS. 19, 21, 23, 31, 35 AND 44). SN 79-087,607. PUB. 1-18-2011. FILED 8-13-2010.  
 3,940,083. **DAN'S COMP AND DESIGN**. XP INNOVATION, LLC, DBA DAN'S COMP, MULTIPLE CLASS, (INT. CLS. 12, 18, 20 AND 25), (U.S. CLS. 1, 2, 3, 13, 19, 21, 22, 23, 25, 31, 32, 35, 39, 41, 44 AND 50). SN 85-003,315. PUB. 1-18-2011. FILED 3-31-2010.  
 3,940,093 ( *See Class 7 for this trademark*).  
 3,940,104 ( *See Class 7 for this trademark*).  
 3,940,153. **CARZGO AND DESIGN**. DAIMLER AG, MULTIPLE CLASS, (INT. CLS. 12, 25, 28, 39 AND 41), (U.S. CLS. 19, 21, 22, 23, 31, 35, 38, 39, 44, 50, 100, 101, 105 AND 107). SN 85-033,249. PUB. 1-18-2011. FILED 5-7-2010.  
 3,940,155. **CONVEYORE (STANDARD CHARACTER)**. TYCROP INVESTMENTS, LTD., (U.S. CLS. 19, 21, 23, 31, 35 AND 44). SN 85-034,405. PUB. 1-18-2011. FILED 5-10-2010.  
 3,940,262 ( *See Class 7 for this trademark*).  
 3,940,275. **VAN (STANDARD CHARACTER)**. FOX FACTORY, INC., (U.S. CLS. 19, 21, 23, 31, 35 AND 44). SN 85-070,550. PUB. 10-12-2010. FILED 6-24-2010.  
 3,940,301. **WEATHERTECH (STYLIZED)**. MACNEIL IP LLC, MULTIPLE CLASS, (INT. CLS. 12, 22 AND 27), (U.S. CLS. 1, 2, 7, 19, 20, 21, 22, 23, 31, 35, 37, 42, 44 AND 50). SN 85-078,807. PUB. 1-18-2011. FILED 7-6-2010.  
 3,940,494. **BOHEMIAN (STANDARD CHARACTER)**. CONFEDERATE MOTOR COMPANY, (U.S. CLS. 19, 21, 23, 31, 35 AND 44). SN 85-097,625. PUB. 1-18-2011. FILED 8-1-2010.  
 3,940,522. **BOSE (STYLIZED)**. BOSE CORPORATION, (U.S. CLS. 19, 21, 23, 31, 35 AND 44). SN 85-098,136. PUB. 1-18-2011. FILED 8-2-2010.  
 3,940,555. **KMX (STANDARD CHARACTER)**. KMX, MULTIPLE CLASS, (INT. CLS. 12 AND 28), (U.S. CLS. 19, 21, 22, 23, 31, 35, 38, 44 AND 50). SN 85-098,641. PUB. 1-18-2011. FILED 8-3-2010.  
 3,940,827. **BONANZA (STANDARD CHARACTER)**. HAWKER BEECHCRAFT CORPORATION, (U.S. CLS. 19, 21, 23, 31, 35 AND 44). SN 85-102,609. PUB. 1-18-2011. FILED 8-7-2010.  
 3,940,877. **I BOOBIES! AND DESIGN**. THE KEEP A BREAST FOUNDATION, (U.S. CLS. 19, 21, 23, 31, 35 AND 44). SN 85-108,728. PUB. 1-18-2011. FILED 8-16-2010.  
 3,940,956. **XJL (STANDARD CHARACTER)**. JAGUAR CARS LIMITED, (U.S. CLS. 19, 21, 23, 31, 35 AND 44). SN 85-139,497. PUB. 1-18-2011. FILED 9-28-2010.

---

## CLASS 13—FIREARMS

3,939,373. **THE MAKO GROUP AND DESIGN**. MAKO SECURITY, INC., (U.S. CLS. 2 AND 9). SN 76-702,668. PUB. 1-18-2011. FILED 4-26-2010.  
 3,940,087. **MOUNT-N-SLOT (STANDARD CHARACTER)**. IMPACT WEAPONS COMPONENTS, LLC, (U.S. CLS. 2 AND 9). SN 85-005,760. PUB. 1-18-2011. FILED 4-3-2010.

**CLASS 14—JEWELRY**

- 3,939,359. **RG AND DESIGN**. RAY GRIFFITHS, INC., (U.S. CLS. 2, 27, 28 AND 50). SN 76-700,383. PUB. 1-18-2011. FILED 11-16-2009.
- 3,939,367. **FREEDOM STONES (STANDARD CHARACTER)**. FREEDOM STONES INTERNATIONAL, (U.S. CLS. 2, 27, 28 AND 50). SN 76-701,777. PUB. 1-18-2011. FILED 2-24-2010.
- 3,939,417. **SHI SYMBOL (STANDARD CHARACTER)**. SHI SYMBOL INTERNATIONAL PTY LTD, MULTIPLE CLASS, (INT. CLS. 14 AND 45), (U.S. CLS. 2, 27, 28, 50, 100 AND 101). SN 77-423,332. PUB. 1-18-2011. FILED 3-17-2008.
- 3,939,582. **MERIDYTH MAX (STANDARD CHARACTER)**. HOOK-ON EARRINGS LLC, DBA MERIDYTH MAX, HOOK-ON EARRINGS, (U.S. CLS. 2, 27, 28 AND 50). SN 77-869,816. PUB. 1-18-2011. FILED 11-10-2009.
- 3,939,598. **BORELLY PEARLS (STANDARD CHARACTER)**. BORELLY'S, INC., (U.S. CLS. 2, 27, 28 AND 50). SN 77-885,515. PUB. 1-18-2011. FILED 12-3-2009.
- 3,939,599. **BP BORELLY PEARLS AND DESIGN**. BORELLY'S, INC., (U.S. CLS. 2, 27, 28 AND 50). SN 77-885,564. PUB. 1-18-2011. FILED 12-3-2009.
- 3,939,666. **GLITTERAZZI (STANDARD CHARACTER)**. MULTICRAFT IMPORTS INC., MULTIPLE CLASS, (INT. CLS. 14 AND 16), (U.S. CLS. 2, 5, 22, 23, 27, 28, 29, 37, 38 AND 50). SN 77-924,152. PUB. 1-18-2011. FILED 1-29-2010.
- 3,939,895 ( *See Class 9 for this trademark*).
- 3,939,922. **PEREGRINATIO AD PETRI SEDEM AND DESIGN**. AMMINISTRAZIONE PATRIMONIO SEDE APOSTOLICA, MULTIPLE CLASS, (INT. CLS. 14, 16, 18, 25, 28, 35, 41 AND 43), (U.S. CLS. 1, 2, 3, 5, 22, 23, 27, 28, 29, 37, 38, 39, 41, 50, 100, 101, 102 AND 107). SN 79-075,993. PUB. 1-18-2011. FILED 1-29-2009.
- 3,939,931. **KATOWA (STYLIZED)**. KATUSHA MANAGEMENT SA, MULTIPLE CLASS, (INT. CLS. 14, 18, 24, 25, 28, 35, 36, 39, 41 AND 45), (U.S. CLS. 1, 2, 3, 22, 23, 27, 28, 38, 39, 41, 42, 50, 100, 101, 102, 105 AND 107). SN 79-077,314. PUB. 1-18-2011. FILED 9-24-2009.
- 3,939,936 ( *See Class 3 for this trademark*).
- 3,939,954 ( *See Class 12 for this trademark*).
- 3,940,002 ( *See Class 12 for this trademark*).
- 3,940,026. **TEDELON (STYLIZED)**. TAIZILONG HOLDING GROUP LIMITED COMPANY, MULTIPLE CLASS, (INT. CLS. 14, 18, 20, 25, 34, 35 AND 43), (U.S. CLS. 1, 2, 3, 8, 9, 13, 17, 22, 25, 27, 28, 32, 39, 41, 50, 100, 101 AND 102). SN 79-083,811. PUB. 1-18-2011. FILED 2-9-2010.
- 3,940,029 ( *See Class 3 for this trademark*).
- 3,940,080. **RUSSIAN LEMURIAN - SACRED SCRIBE (STANDARD CHARACTER)**. DAVID J. GEIGER, (U.S. CLS. 2, 27, 28 AND 50). SN 85-001,315. PUB. 11-30-2010. FILED 3-29-2010.
- 3,940,111. **GREENWICH JEWELERS (STANDARD CHARACTER)**. GAMBALE, CHRISTINA, DBA GREENWICH JEWELERS, AND GANDIA, JENNIFER, DBA GREENWICH JEWELERS, (U.S. CLS. 2, 27, 28 AND 50). SN 85-015,555. PUB. 1-18-2011. FILED 4-16-2010.
- 3,940,128. **BUTTERFLY MEADOW (STANDARD CHARACTER)**. LENOX CORPORATION, (U.S. CLS. 2, 27, 28 AND 50). SN 85-025,446. PUB. 1-18-2011. FILED 4-28-2010.
- 3,940,335. **FRIEDA & NELLIE (STANDARD CHARACTER)**. FRIEDA & NELLIE INC., (U.S. CLS. 2, 27, 28 AND 50). SN 85-085,726. PUB. 1-18-2011. FILED 7-15-2010.
- 3,940,349. **100%GUMDROP (STANDARD CHARACTER)**. LITT/COLE CORP., DBA 100% GUMDROP, (U.S. CLS. 2, 27, 28 AND 50). SN 85-087,988. PUB. 1-18-2011. FILED 7-19-2010.
- 3,940,382. **U.S. CHALLENGE COINS AND DESIGN**. MULLHOLLAND, ADAM, (U.S. CLS. 2, 27, 28 AND 50). SN 85-092,815. PUB. 1-18-2011. FILED 7-26-2010.
- 3,940,396. **UNIVERSITY OF IDAHO (STANDARD CHARACTER)**. UNIVERSITY OF IDAHO, MULTIPLE CLASS, (INT. CLS. 14, 16, 21, 24, 25 AND 41), (U.S. CLS. 2, 5, 13, 22, 23, 27, 28, 29, 30, 33, 37, 38, 39, 40, 42, 50, 100, 101 AND 107). SN 85-094,124. PUB. 1-18-2011. FILED 7-27-2010.
- 3,940,405. **SPIRIT ARTIST (STANDARD CHARACTER)**. SPIRIT ARTIST, LLC, (U.S. CLS. 2, 27, 28 AND 50). SN 85-094,406. PUB. 1-18-2011. FILED 7-28-2010.
- 3,940,437. **CHOOSE HOPE (STANDARD CHARACTER)**.

- CHOOSE HOPE INC.**, (U.S. CLS. 2, 27, 28 AND 50). SN 85-096,552. PUB. 1-18-2011. FILED 7-30-2010.
- 3,940,458 ( *See Class 3 for this trademark*).
- 3,940,599. **KIRAKIRA (STANDARD CHARACTER)**. SUZANNE SOMERSALL, LLC, (U.S. CLS. 2, 27, 28 AND 50). SN 85-099,482. PUB. 1-18-2011. FILED 8-3-2010.
- 3,940,616. **MR. KATE (STANDARD CHARACTER)**. ALBRECHT, KATE, DBA MR. KATE, (U.S. CLS. 2, 27, 28 AND 50). SN 85-099,772. PUB. 1-18-2011. FILED 8-4-2010.
- 3,940,644. **PRESCOTT (STANDARD CHARACTER)**. MOVADO LLC, (U.S. CLS. 2, 27, 28 AND 50). SN 85-100,126. PUB. 1-18-2011. FILED 8-4-2010.
- 3,940,653. **CRITERION (STANDARD CHARACTER)**. MOVADO LLC, (U.S. CLS. 2, 27, 28 AND 50). SN 85-100,180. PUB. 1-18-2011. FILED 8-4-2010.
- 3,940,781. **LETEL (STANDARD CHARACTER)**. DURRELL, CHRISTOPHER, (U.S. CLS. 2, 27, 28 AND 50). SN 85-102,014. PUB. 1-18-2011. FILED 8-6-2010.
- 3,940,792. **PROENZA SCHOULER (STANDARD CHARACTER)**. PROENZA SCHOULER, LLC, MULTIPLE CLASS, (INT. CLS. 14 AND 18), (U.S. CLS. 1, 2, 3, 22, 27, 28, 41 AND 50). SN 85-102,204. PUB. 1-18-2011. FILED 8-6-2010.
- 3,940,825. **MANIC PANIC (STANDARD CHARACTER)**. TISH & SNOOKY'S N.Y.C. INC., MULTIPLE CLASS, (INT. CLS. 14, 18 AND 25), (U.S. CLS. 1, 2, 3, 22, 27, 28, 39, 41 AND 50). SN 85-102,563. PUB. 1-18-2011. FILED 8-7-2010.

**CLASS 15—MUSICAL INSTRUMENTS**

- 3,939,890 ( *See Class 9 for this trademark*).
- 3,940,131 ( *See Class 9 for this trademark*).
- 3,940,310. **KICKDISK (STANDARD CHARACTER)**. KICKDISK, LLC, (U.S. CLS. 2, 21 AND 36). SN 85-081,116. PUB. 1-18-2011. FILED 7-9-2010.

**CLASS 16—PAPER GOODS AND PRINTED MATTER**

- 3,939,348. **SOS AND DESIGN**. FRANK, LARRY D., (U.S. CLS. 2, 5, 22, 23, 29, 37, 38 AND 50). SN 76-504,831. PUB. 10-12-2010. FILED 4-7-2003.
- 3,939,349 ( *See Class 3 for this trademark*).
- 3,939,351 ( *See Class 11 for this trademark*).
- 3,939,364. **DENTAL DECKS (STANDARD CHARACTER)**. DENTAL DECKS, INC., (U.S. CLS. 2, 5, 22, 23, 29, 37, 38 AND 50). SN 76-701,711. PUB. 1-18-2011. FILED 2-19-2010.
- 3,939,394. **MEDIAPLANET (STANDARD CHARACTER)**. MEDIAPLANET INTERNATIONAL AB, MULTIPLE CLASS, (INT. CLS. 16, 35, 36, 38, 41, 42 AND 44), (U.S. CLS. 2, 5, 22, 23, 29, 37, 38, 50, 100, 101, 102, 104 AND 107). SN 77-105,368. PUB. 1-18-2011. FILED 2-12-2007.
- 3,939,405 ( *See Class 9 for this trademark*).
- 3,939,412. **SMILING FEET (STANDARD CHARACTER)**. CRYSTAL CLEAR SPA AND LEISURE PRODUCTS INC., (U.S. CLS. 2, 5, 22, 23, 29, 37, 38 AND 50). SN 77-368,253. PUB. 1-18-2011. FILED 1-10-2008.
- 3,939,418. **THE PRO RIDER (STANDARD CHARACTER)**. AMERICAN SNOWSPORTS EDUCATION ASSOCIATION, INC. - EDUCATION FOUNDATION, (U.S. CLS. 2, 5, 22, 23, 29, 37, 38 AND 50). SN 77-438,294. PUB. 1-18-2011. FILED 4-2-2008.
- 3,939,433 ( *See Class 9 for this trademark*).
- 3,939,440 ( *See Class 10 for this trademark*).
- 3,939,461 ( *See Class 3 for this trademark*).
- 3,939,466. **WASHBURN UNIVERSITY (STANDARD CHARACTER)**. WASHBURN UNIVERSITY, MULTIPLE CLASS, (INT. CLS. 16, 25 AND 41), (U.S. CLS. 2, 5, 22, 23, 29, 37, 38, 39, 50, 100, 101 AND 107). SN 77-707,567. PUB. 1-18-2011. FILED 4-6-2009.
- 3,939,481 ( *See Class 5 for this trademark*).
- 3,939,545. **NATURAL AWAKENINGS HEALTHY LIVING. HEALTHY PLANET. (STYLIZED)**. NATURAL AWAKENINGS PUBLISHING CORPORATION, AKA NATURAL

- AWAKENINGS, (U.S. CLS. 2, 5, 22, 23, 29, 37, 38 AND 50). SN 77-827,608. PUB. 1-18-2011. FILED 9-16-2009.
- 3,939,569 ( *See Class 6 for this trademark*).
- 3,939,581. **SCOREBOARD MONTHLY (STANDARD CHARACTER)**. FRANCHISE SPORTS MARKETING, LLC, (U.S. CLS. 2, 5, 22, 23, 29, 37, 38 AND 50). SN 77-869,186. PUB. 1-18-2011. FILED 11-10-2009.
- 3,939,625. **SERIOUSLY FUN EDUCATION (STANDARD CHARACTER)**. KNOLWEDGE RETRIEVER, LLC, (U.S. CLS. 2, 5, 22, 23, 29, 37, 38 AND 50). SN 77-912,431. PUB. 1-18-2011. FILED 1-14-2010.
- 3,939,638. **EARTH SMILING AND DESIGN. ON THE ROCKS PRODUCTIONS LLC**, (U.S. CLS. 2, 5, 22, 23, 29, 37, 38 AND 50). SN 77-917,708. PUB. 1-18-2011. FILED 1-22-2010.
- 3,939,646. **WHAT'S WRONG? (STANDARD CHARACTER)**. HIGHLIGHTS FOR CHILDREN, INC., (U.S. CLS. 2, 5, 22, 23, 29, 37, 38 AND 50). SN 77-920,586. PUB. 1-18-2011. FILED 1-26-2010.
- 3,939,666 ( *See Class 14 for this trademark*).
- 3,939,684. **IN THE STUDIO (STANDARD CHARACTER)**. BROWN, JACOB P., (U.S. CLS. 2, 5, 22, 23, 29, 37, 38 AND 50). SN 77-929,370. PUB. 1-18-2011. FILED 2-5-2010.
- 3,939,727. **UNITY IS STRENGTH. KNOWLEDGE IS POWER. ATTITUDE IS EVERYTHING. (STANDARD CHARACTER)**. LANCE ARMSTRONG FOUNDATION, (U.S. CLS. 2, 5, 22, 23, 29, 37, 38 AND 50). SN 77-936,508. PUB. 1-18-2011. FILED 2-16-2010.
- 3,939,730. **MARINE PARENTS A PLACE TO CONNECT & SHARE (STANDARD CHARACTER)**. MARINEPARENTS-COM, INC., MULTIPLE CLASS, (INT. CLS. 16, 35, 36, 38, 41 AND 45), (U.S. CLS. 2, 5, 22, 23, 29, 37, 38, 50, 100, 101, 102, 104 AND 107). SN 77-936,698. PUB. 1-18-2011. FILED 2-16-2010.
- 3,939,746. **PAINT THE MOMENT (STANDARD CHARACTER)**. YONG LI, DBA LUCKY88 ENTERPRISES, MULTIPLE CLASS, (INT. CLS. 16 AND 41), (U.S. CLS. 2, 5, 22, 23, 29, 37, 38, 50, 100, 101 AND 107). SN 77-939,502. PUB. 1-18-2011. FILED 2-19-2010.
- 3,939,747. **FOREVER BUFFS (STANDARD CHARACTER)**. THE REGENTS OF THE UNIVERSITY OF COLORADO, MULTIPLE CLASS, (INT. CLS. 16, 25 AND 35), (U.S. CLS. 2, 5, 22, 23, 29, 37, 38, 39, 50, 100, 101 AND 102). SN 77-939,596. PUB. 1-18-2011. FILED 2-19-2010.
- 3,939,753. **STRATEGIST (STANDARD CHARACTER)**. NEW YORK MEDIA, LLC, (U.S. CLS. 2, 5, 22, 23, 29, 37, 38 AND 50). SN 77-940,194. PUB. 1-18-2011. FILED 2-19-2010.
- 3,939,754. **THE APPROVAL MATRIX (STANDARD CHARACTER)**. NEW YORK MEDIA, LLC, (U.S. CLS. 2, 5, 22, 23, 29, 37, 38 AND 50). SN 77-940,196. PUB. 1-18-2011. FILED 2-19-2010.
- 3,939,756. **THE LITTLE PURPLE BOOK (STANDARD CHARACTER)**. SAINT ROBERT BELLARMINE TRUST, (U.S. CLS. 2, 5, 22, 23, 29, 37, 38 AND 50). SN 77-940,723. PUB. 1-18-2011. FILED 2-20-2010.
- 3,939,758. **THE LOOK BOOK (STANDARD CHARACTER)**. NEW YORK MEDIA, LLC, (U.S. CLS. 2, 5, 22, 23, 29, 37, 38 AND 50). SN 77-941,035. PUB. 1-18-2011. FILED 2-22-2010.
- 3,939,769. **MAIN STREET COLLECTION AND DESIGN**. DELUXE ENTERPRISE OPERATIONS, INC., (U.S. CLS. 2, 5, 22, 23, 29, 37, 38 AND 50). SN 77-945,177. PUB. 1-18-2011. FILED 2-25-2010.
- 3,939,779. **PAINTSCOOPER (STANDARD CHARACTER)**. MAJOR, WILLIS G., (U.S. CLS. 2, 5, 22, 23, 29, 37, 38 AND 50). SN 77-947,965. PUB. 1-18-2011. FILED 3-2-2010.
- 3,939,796. **TOTAL EDUCATION SOLUTIONS (STANDARD CHARACTER)**. TOTAL EDUCATION SOLUTIONS, INC., MULTIPLE CLASS, (INT. CLS. 16 AND 41), (U.S. CLS. 2, 5, 22, 23, 29, 37, 38, 50, 100, 101 AND 107). SN 77-952,486. PUB. 1-18-2011. FILED 3-6-2010.
- 3,939,815 ( *See Class 9 for this trademark*).
- 3,939,838. **PROVEN KNOWLEDGE. POWERFUL RESULTS (STANDARD CHARACTER)**. AMERICAN INSTITUTE FOR CHARTERED PROPERTY CASUALTY UNDERWRITERS, MULTIPLE CLASS, (INT. CLS. 16, 35 AND 41), (U.S. CLS. 2, 5, 22, 23, 29, 37, 38, 50, 100, 101, 102 AND 107). SN 77-964,694. PUB. 1-18-2011. FILED 3-22-2010.
- 3,939,872. **SOUL OF AFRICA (STANDARD CHARACTER)**. SOUL OF AFRICA, (U.S. CLS. 2, 5, 22, 23, 29, 37, 38 AND 50). SN 78-811,017. PUB. 1-18-2011. FILED 2-9-2006.
- 3,939,890 ( *See Class 9 for this trademark*).
- 3,939,895 ( *See Class 9 for this trademark*).
- 3,939,904 ( *See Class 9 for this trademark*).
- 3,939,913 ( *See Class 3 for this trademark*).
- 3,939,922 ( *See Class 14 for this trademark*).
- 3,939,924. **MAP18 (STANDARD CHARACTER)**. MAP18 GMBH, (U.S. CLS. 2, 5, 22, 23, 29, 37, 38 AND 50). SN 79-076,586. PUB. 1-18-2011. FILED 8-13-2009.
- 3,939,925 ( *See Class 9 for this trademark*).
- 3,939,928. **BABKINY AND DESIGN**. OBSHCHESTVO S OGRANICHENNOY; OTVETSTVENNOST'YU; "BABKINY SEMECHKI", MULTIPLE CLASS, (INT. CLS. 16, 29, 30 AND 35), (U.S. CLS. 2, 5, 22, 23, 29, 37, 38, 46, 50, 100, 101 AND 102). SN 79-077,185. PUB. 6-15-2010. FILED 3-27-2009.
- 3,939,936 ( *See Class 3 for this trademark*).
- 3,939,997. **MUNDOCOM (STYLIZED)**. SCAP, MULTIPLE CLASS, (INT. CLS. 16, 35 AND 41), (U.S. CLS. 2, 5, 22, 23, 29, 37, 38, 50, 100, 101, 102 AND 107). SN 79-081,686. PUB. 1-18-2011. FILED 2-11-2010.
- 3,939,998 ( *See Class 9 for this trademark*).
- 3,940,003 ( *See Class 9 for this trademark*).
- 3,940,021 ( *See Class 9 for this trademark*).
- 3,940,029 ( *See Class 3 for this trademark*).
- 3,940,035. **MISCELLANEOUS DESIGN**. CEWE COLOR AG & CO. OHG, MULTIPLE CLASS, (INT. CLS. 16 AND 40), (U.S. CLS. 2, 5, 22, 23, 29, 37, 38, 50, 100, 103 AND 106). SN 79-084,730. PUB. 1-18-2011. FILED 5-6-2010.
- 3,940,056 ( *See Class 9 for this trademark*).
- 3,940,091 ( *See Class 9 for this trademark*).
- 3,940,142. **THE SHAPE OF MUSIC (STANDARD CHARACTER)**. FANSLER, JENNI, (U.S. CLS. 2, 5, 22, 23, 29, 37, 38 AND 50). SN 85-030,185. PUB. 1-18-2011. FILED 5-4-2010.
- 3,940,143. **PRAY ME A STORY LOYOLA PRESS AND DESIGN**. CHICAGO PROVINCE OF THE SOCIETY OF JESUS, (U.S. CLS. 2, 5, 22, 23, 29, 37, 38 AND 50). SN 85-030,555. PUB. 1-18-2011. FILED 5-5-2010.
- 3,940,145. **GOD'S SIDE (STANDARD CHARACTER)**. HENDRICKSON, L AMY, (U.S. CLS. 2, 5, 22, 23, 29, 37, 38 AND 50). SN 85-031,348. PUB. 1-18-2011. FILED 5-6-2010.
- 3,940,195. **THE GREEK LETTERS LAMBDA THETA NU. AND DESIGN**. LAMBDA THETA NU SORORITY, INC., MULTIPLE CLASS, (INT. CLS. 16, 18 AND 25), (U.S. CLS. 1, 2, 3, 5, 22, 23, 29, 37, 38, 39, 41 AND 50). SN 85-046,722. PUB. 1-18-2011. FILED 5-24-2010.
- 3,940,222. **M (STYLIZED)**. MCMONIGLE, JOHN, (U.S. CLS. 2, 5, 22, 23, 29, 37, 38 AND 50). SN 85-056,386. PUB. 1-18-2011. FILED 6-7-2010.
- 3,940,228 ( *See Class 6 for this trademark*).
- 3,940,243. **SEVEN PERFECT DAYS (STANDARD CHARACTER)**. PRIDE PUBLICATIONS INC., (U.S. CLS. 2, 5, 22, 23, 29, 37, 38 AND 50). SN 85-062,371. PUB. 1-18-2011. FILED 6-14-2010.
- 3,940,248 ( *See Class 9 for this trademark*).
- 3,940,249 ( *See Class 9 for this trademark*).
- 3,940,250 ( *See Class 9 for this trademark*).
- 3,940,251 ( *See Class 9 for this trademark*).
- 3,940,252 ( *See Class 9 for this trademark*).
- 3,940,256. **EMPIRE SIGNS & GRAPHICS (STANDARD CHARACTER)**. ASHLEY, PEPE DAVID, DBA EMPIRE SIGNS & GRAPHICS, (U.S. CLS. 2, 5, 22, 23, 29, 37, 38 AND 50). SN 85-065,435. PUB. 1-18-2011. FILED 6-17-2010.
- 3,940,274. **WIZARD WALL (STANDARD CHARACTER)**. WIZARD WALL, INC., (U.S. CLS. 2, 5, 22, 23, 29, 37, 38 AND 50). SN 85-070,475. PUB. 1-18-2011. FILED 6-24-2010.
- 3,940,311. **RESTAURANT FACILITY BUSINESS (STANDARD CHARACTER)**. FRANCE PUBLICATIONS, INC., (U.S. CLS. 2, 5, 22, 23, 29, 37, 38 AND 50). SN 85-081,147. PUB. 1-18-2011. FILED 7-9-2010.
- 3,940,336. **JÄGERMEISTER RACING (STANDARD CHARACTER)**. MAST-JÄGERMEISTER AG, MULTIPLE CLASS, (INT. CLS. 16, 24, 25, 33 AND 41), (U.S. CLS. 2, 5, 22, 23, 29, 37, 38, 39, 42, 47, 49, 50, 100, 101 AND 107). SN 85-085,788. PUB. 1-18-2011. FILED 7-15-2010.
- 3,940,341. **TULSA TALONS AND DESIGN**. TULSA PRO ARENA FOOTBALL, LLC, DBA TULSA TALONS, MULTIPLE CLASS, (INT. CLS. 16, 25 AND 41), (U.S. CLS. 2, 5, 22, 23, 29, 37, 38, 39, 50, 100, 101 AND 107). SN 85-086,714. PUB.

- 1-18-2011. FILED 7-16-2010.
- 3,940,377. **HERALD OF TRUTH HIS WORD FOR HIS WORLD. EVERY DAY (STANDARD CHARACTER)**, HERALD OF TRUTH MINISTRIES, INC., MULTIPLE CLASS, (INT. CLS. 16 AND 41), (U.S. CLS. 2, 5, 22, 23, 29, 37, 38, 50, 100, 101 AND 107). SN 85-091,782. PUB. 1-18-2011. FILED 7-23-2010.
- 3,940,396 ( *See Class 14 for this trademark*).
- 3,940,421. **USE IT FOR LIFE (STANDARD CHARACTER)**, TRIBUNE COMPANY, MULTIPLE CLASS, (INT. CLS. 16 AND 41), (U.S. CLS. 2, 5, 22, 23, 29, 37, 38, 50, 100, 101 AND 107). SN 85-095,721. PUB. 1-18-2011. FILED 7-29-2010.
- 3,940,443. **VERANO (STANDARD CHARACTER)**, NOBEL-COM, LLC, (U.S. CLS. 2, 5, 22, 23, 29, 37, 38 AND 50). SN 85-096,754. PUB. 1-18-2011. FILED 7-30-2010.
- 3,940,477. **COUNTERTHINK (STANDARD CHARACTER)**, MICHAEL A. ADAMS, (U.S. CLS. 2, 5, 22, 23, 29, 37, 38 AND 50). SN 85-097,451. PUB. 1-18-2011. FILED 7-31-2010.
- 3,940,483. **DR LEAF SWITCH ON YOUR BRAIN AND DESIGN. SWOYB PROPERTIES, LP**, (U.S. CLS. 2, 5, 22, 23, 29, 37, 38 AND 50). SN 85-097,500. PUB. 1-18-2011. FILED 7-31-2010.
- 3,940,496. **GIVE YOUR PRESENT A FUTURE (STANDARD CHARACTER)**, LORI ALSENIH, DBA EVER GIVING BOX, (U.S. CLS. 2, 5, 22, 23, 29, 37, 38 AND 50). SN 85-097,678. PUB. 1-18-2011. FILED 8-1-2010.
- 3,940,497. **EVER GIVING BOX (STANDARD CHARACTER)**, ALSENIH, LORI, DBA EVER GIVING BOX, (U.S. CLS. 2, 5, 22, 23, 29, 37, 38 AND 50). SN 85-097,684. PUB. 1-18-2011. FILED 8-1-2010.
- 3,940,512. **EPICENTER (STANDARD CHARACTER)**, TYNDALE HOUSE PUBLISHERS, INC., (U.S. CLS. 2, 5, 22, 23, 29, 37, 38 AND 50). SN 85-097,952. PUB. 1-18-2011. FILED 8-2-2010.
- 3,940,548. **APPS ON AND DESIGN**, XU, REX FANG, (U.S. CLS. 2, 5, 22, 23, 29, 37, 38 AND 50). SN 85-098,610. PUB. 1-18-2011. FILED 8-3-2010.
- 3,940,563. **ILIKE (STANDARD CHARACTER)**, ISCHOLAR, INC., (U.S. CLS. 2, 5, 22, 23, 29, 37, 38 AND 50). SN 85-098,794. PUB. 1-18-2011. FILED 8-3-2010.
- 3,940,567. **IHEART (STANDARD CHARACTER)**, ISCHOLAR, INC., (U.S. CLS. 2, 5, 22, 23, 29, 37, 38 AND 50). SN 85-098,854. PUB. 1-18-2011. FILED 8-3-2010.
- 3,940,580. **CLEAR MAGAZINE (STANDARD CHARACTER)**, CLEAR CUSTOM LLC, (U.S. CLS. 2, 5, 22, 23, 29, 37, 38 AND 50). SN 85-099,136. PUB. 1-18-2011. FILED 8-3-2010.
- 3,940,632 ( *See Class 9 for this trademark*).
- 3,940,656. **THE EX (STANDARD CHARACTER)**, C.S.B. COMMODITIES, INC., (U.S. CLS. 2, 5, 22, 23, 29, 37, 38 AND 50). SN 85-100,203. PUB. 1-18-2011. FILED 8-4-2010.
- 3,940,679. **PLAIN SPOKEN CARDS (STANDARD CHARACTER)**, FERRY, DAVID K., (U.S. CLS. 2, 5, 22, 23, 29, 37, 38 AND 50). SN 85-100,557. PUB. 1-18-2011. FILED 8-5-2010.
- 3,940,715. **[KEY]WORDS (STANDARD CHARACTER)**, ALLIANCE OF VISUAL ARTISTS, DBA STOCK ARTISTS ALLIANCE, (U.S. CLS. 2, 5, 22, 23, 29, 37, 38 AND 50). SN 85-100,988. PUB. 1-18-2011. FILED 8-5-2010.
- 3,940,736. **BY MY TOUCH (STANDARD CHARACTER)**, BARON, WENDY, MULTIPLE CLASS, (INT. CLS. 16 AND 18), (U.S. CLS. 1, 2, 3, 5, 22, 23, 29, 37, 38, 41 AND 50). SN 85-101,319. PUB. 1-18-2011. FILED 8-5-2010.
- 3,940,802. **LIFE IS BLESSED (STANDARD CHARACTER)**, SHARON LYNN CAMPBELL, LLC, (U.S. CLS. 2, 5, 22, 23, 29, 37, 38 AND 50). SN 85-102,319. PUB. 1-18-2011. FILED 8-6-2010.
- 3,940,937 ( *See Class 9 for this trademark*).
- 3,940,940. **HAPPY DAYS & NIGHTS (STANDARD CHARACTER)**, ASSOCIATED HYGIENIC PRODUCTS LLC, (U.S. CLS. 2, 5, 22, 23, 29, 37, 38 AND 50). SN 85-128,998. PUB. 1-18-2011. FILED 9-14-2010.
- AND 50). SN 77-683,326. PUB. 1-18-2011. FILED 3-4-2009.
- 3,939,705. **FOREVER TURF (STANDARD CHARACTER)**, CALIBER LEASING, LLC, (U.S. CLS. 1, 5, 12, 13, 35 AND 50). SN 77-933,672. PUB. 1-18-2011. FILED 2-11-2010.
- 3,939,857. **R CAST AND DESIGN**, REYNOLDS POLYMER TECHNOLOGY, INC., DBA R-CAST, (U.S. CLS. 1, 5, 12, 13, 35 AND 50). SN 77-968,679. PUB. 1-18-2011. FILED 3-25-2010.
- 3,939,911 ( *See Class 6 for this trademark*).
- 3,939,961. **VOP (STANDARD CHARACTER)**, DENKI KAGAKU KOGYO KABUSHIKI KAISHA, (U.S. CLS. 1, 5, 12, 13, 35 AND 50). SN 79-080,420. PUB. 1-18-2011. FILED 2-9-2010.
- 3,939,977 ( *See Class 1 for this trademark*).
- 3,940,005 ( *See Class 7 for this trademark*).
- 3,940,022 ( *See Class 1 for this trademark*).
- 3,940,023 ( *See Class 1 for this trademark*).
- 3,940,038 ( *See Class 1 for this trademark*).
- 3,940,401. **PLATINUM SHIELD THERMAL REFLECTIVE ATTIC INSULATION AND DESIGN**, GEORGIA ENVIRONMENTAL TECHNOLOGIES, LLC, (U.S. CLS. 1, 5, 12, 13, 35 AND 50). SN 85-094,287. PUB. 1-18-2011. FILED 7-27-2010.
- 3,940,542. **THERMAPATCH (STANDARD CHARACTER)**, DEERY AMERICAN CORPORATION, (U.S. CLS. 1, 5, 12, 13, 35 AND 50). SN 85-098,481. PUB. 1-18-2011. FILED 8-2-2010.
- 3,940,682. **GALA (STYLIZED)**, TIANJIN GALAXY VALVE CO.,LTD, (U.S. CLS. 1, 5, 12, 13, 35 AND 50). SN 85-100,588. PUB. 1-18-2011. FILED 8-5-2010.
- 3,940,843. **FBJ (STANDARD CHARACTER)**, DEERY AMERICAN CORPORATION, (U.S. CLS. 1, 5, 12, 13, 35 AND 50). SN 85-103,381. PUB. 1-18-2011. FILED 8-9-2010.
- 3,940,846. **THERMACRETE (STANDARD CHARACTER)**, DEERY AMERICAN CORPORATION, (U.S. CLS. 1, 5, 12, 13, 35 AND 50). SN 85-103,432. PUB. 1-18-2011. FILED 8-9-2010.
- 3,940,848. **RRM (STANDARD CHARACTER)**, DEERY AMERICAN CORPORATION, (U.S. CLS. 1, 5, 12, 13, 35 AND 50). SN 85-103,446. PUB. 1-18-2011. FILED 8-9-2010.
- 3,940,850. **SAMA (STANDARD CHARACTER)**, DEERY AMERICAN CORPORATION, (U.S. CLS. 1, 5, 12, 13, 35 AND 50). SN 85-103,457. PUB. 1-18-2011. FILED 8-9-2010.
- 3,940,856. **DEERY (STANDARD CHARACTER)**, DEERY AMERICAN CORPORATION, MULTIPLE CLASS, (INT. CLS. 17 AND 19), (U.S. CLS. 1, 5, 12, 13, 33, 35 AND 50). SN 85-103,514. PUB. 1-18-2011. FILED 8-9-2010.
- 3,940,952. **SURE FORM (STANDARD CHARACTER)**, FOAMEX INNOVATIONS OPERATING COMPANY, (U.S. CLS. 1, 5, 12, 13, 35 AND 50). SN 85-137,386. PUB. 1-18-2011. FILED 9-24-2010.

---

## CLASS 18—LEATHER GOODS

## CLASS 17—RUBBER GOODS

- 3,939,358. **MISCELLANEOUS DESIGN**, HERMES INTERNATIONAL, (U.S. CLS. 1, 2, 3, 22 AND 41). SN 76-700,119. PUB. 1-18-2011. FILED 10-29-2009.
- 3,939,449. **LEBEIGE AND DESIGN**, CHEIL INDUSTRIES INC., MULTIPLE CLASS, (INT. CLS. 18, 25 AND 35), (U.S. CLS. 1, 2, 3, 22, 39, 41, 100, 101 AND 102). SN 77-642,150. PUB. 1-18-2011. FILED 12-31-2008.
- 3,939,514. **KATYDID (STANDARD CHARACTER)**, SHOPFORBAGS, INC., MULTIPLE CLASS, (INT. CLS. 18, 25 AND 35), (U.S. CLS. 1, 2, 3, 22, 39, 41, 100, 101 AND 102). SN 77-794,501. PUB. 1-18-2011. FILED 7-31-2009.
- 3,939,548. **KATYDID AND DESIGN**, SHOPFORBAGS, INC., MULTIPLE CLASS, (INT. CLS. 18 AND 25), (U.S. CLS. 1, 2, 3, 22, 39 AND 41). SN 77-837,036. PUB. 1-18-2011. FILED 9-29-2009.
- 3,939,612. **LUX DE VILLE (STANDARD CHARACTER)**, LUX DE VILLE INC, (U.S. CLS. 1, 2, 3, 22 AND 41). SN 77-901,737. PUB. 1-18-2011. FILED 12-28-2009.
- 3,939,629 ( *See Class 3 for this trademark*).
- 3,939,886. **THE FLEXX (STYLIZED)**, AXEL KAISER, MULTIPLE CLASS, (INT. CLS. 18 AND 25), (U.S. CLS. 1, 2, 3, 22, 39 AND 41). SN 79-063,475. PUB. 12-29-2009. FILED 11-7-2008.
- 3,939,890 ( *See Class 9 for this trademark*).
- 3,939,895 ( *See Class 9 for this trademark*).
- 3,939,913 ( *See Class 3 for this trademark*).



3,939,919. **VERRA BIEN (STYLIZED)**. SHANTOU VERBINI COSTUME CO., LTD., MULTIPLE CLASS, (INT. CLS. 18, 25 AND 26), (U.S. CLS. 1, 2, 3, 22, 37, 39, 40, 41, 42 AND 50). SN 79-075,402. PUB. 1-18-2011. FILED 10-7-2009.

3,939,922 ( *See Class 14 for this trademark*).

3,939,931 ( *See Class 14 for this trademark*).

3,939,934. **WIPPE AND DESIGN**. FANTONI SANDRINE, MULTIPLE CLASS, (INT. CLS. 18 AND 25), (U.S. CLS. 1, 2, 3, 22, 39 AND 41). SN 79-077,715. PUB. 1-18-2011. FILED 10-29-2009.

3,939,936 ( *See Class 3 for this trademark*).

3,939,954 ( *See Class 12 for this trademark*).

3,939,960. **DIGITA (STYLIZED)**. TUCANO SRL, (U.S. CLS. 1, 2, 3, 22 AND 41). SN 79-080,360. PUB. 1-18-2011. FILED 8-27-2009.

3,939,995. **E ELEKTRODE AND DESIGN**. GROUPE JAJ, MULTIPLE CLASS, (INT. CLS. 18, 24 AND 25), (U.S. CLS. 1, 2, 3, 22, 39, 41, 42 AND 50). SN 79-081,583. PUB. 1-18-2011. FILED 3-9-2010.

3,940,002 ( *See Class 12 for this trademark*).

3,940,024. **HEINEKEN AND DESIGN**. HEINEKEN BROUWERIJEN B.V., MULTIPLE CLASS, (INT. CLS. 18, 25 AND 32), (U.S. CLS. 1, 2, 3, 22, 39, 41, 45, 46 AND 48). SN 79-083,647. PUB. 1-18-2011. FILED 3-4-2010.

3,940,026 ( *See Class 14 for this trademark*).

3,940,027. **FENDI (STANDARD CHARACTER)**. FENDI ADELE S.R.L., MULTIPLE CLASS, (INT. CLS. 18 AND 25), (U.S. CLS. 1, 2, 3, 22, 39 AND 41). SN 79-084,029. PUB. 1-18-2011. FILED 10-22-2009.

3,940,029 ( *See Class 3 for this trademark*).

3,940,033 ( *See Class 5 for this trademark*).

3,940,083 ( *See Class 12 for this trademark*).

3,940,146. **PUSSEY'S (STANDARD CHARACTER)**. PUSSEY'S (2001) LTD., MULTIPLE CLASS, (INT. CLS. 18, 21, 24, 29 AND 30), (U.S. CLS. 1, 2, 3, 13, 22, 23, 29, 30, 33, 40, 41, 42, 46 AND 50). SN 85-032,130. PUB. 1-18-2011. FILED 5-6-2010.

3,940,195 ( *See Class 16 for this trademark*).

3,940,245. **HOT BOWS AND DESIGN**. SAMSON, DARA, (U.S. CLS. 1, 2, 3, 22 AND 41). SN 85-062,442. PUB. 1-18-2011. FILED 6-14-2010.

3,940,426. **BLUE AVOCADO AND DESIGN**. BLUE AVOCADO, INC., (U.S. CLS. 1, 2, 3, 22 AND 41). SN 85-096,118. PUB. 1-18-2011. FILED 7-29-2010.

3,940,481. **ELLA G AND DESIGN**. CRISPIN OF LYNN, LLC, (U.S. CLS. 1, 2, 3, 22 AND 41). SN 85-097,498. PUB. 1-18-2011. FILED 7-31-2010.

3,940,597. **XAIS (STANDARD CHARACTER)**. AIXA QUINONES, (U.S. CLS. 1, 2, 3, 22 AND 41). SN 85-099,416. PUB. 1-18-2011. FILED 8-4-2010.

3,940,614. **HEARTWARE (STANDARD CHARACTER)**. HEARTWARE, INC., (U.S. CLS. 1, 2, 3, 22 AND 41). SN 85-099,764. PUB. 1-18-2011. FILED 8-4-2010.

3,940,706. **P PARIS HILTON AND DESIGN**. HILTON, PARIS, (U.S. CLS. 1, 2, 3, 22 AND 41). SN 85-100,907. PUB. 1-18-2011. FILED 8-5-2010.

3,940,736 ( *See Class 16 for this trademark*).

3,940,792 ( *See Class 14 for this trademark*).

3,940,825 ( *See Class 14 for this trademark*).

3,940,857. **PINK KOALA DESIGN (STANDARD CHARACTER)**. KATRINA NICOLE GRIFFIS, DBA PINK KOALA DESIGN, (U.S. CLS. 1, 2, 3, 22 AND 41). SN 85-103,527. PUB. 1-18-2011. FILED 8-9-2010.

3,940,923. **TRAVEL BLANKID (STANDARD CHARACTER)**. CABEAU, INC., MULTIPLE CLASS, (INT. CLS. 18, 20 AND 24), (U.S. CLS. 1, 2, 3, 13, 22, 25, 32, 41, 42 AND 50). SN 85-121,299. PUB. 1-18-2011. FILED 9-1-2010.

3,940,950. **DOLLY GIRL BY ANNA SUI (STANDARD CHARACTER)**. ANNA SUI CORP., MULTIPLE CLASS, (INT. CLS. 18 AND 25), (U.S. CLS. 1, 2, 3, 22, 39 AND 41). SN 85-136,636. PUB. 1-18-2011. FILED 9-23-2010.

## CLASS 19—NON-METALLIC BUILDING MATERIALS

3,939,469. **ECOEXCEL (STANDARD CHARACTER)**. ANDERSEN CORPORATION, (U.S. CLS. 1, 12, 33 AND 50). SN 77-

717,255. PUB. 1-18-2011. FILED 4-20-2009.

3,939,490 ( *See Class 6 for this trademark*).

3,939,563. **YUKON (STANDARD CHARACTER)**. BUILDING PRODUCTS OF CANADA CORP./ LA CIE MATERIAUX DE CONSTRUCTION BP CANADA, (U.S. CLS. 1, 12, 33 AND 50). SN 77-852,062. PUB. 1-18-2011. FILED 10-19-2009.

3,939,596. **VENUS (STANDARD CHARACTER)**. HATZ SPAIN, S.A., (U.S. CLS. 1, 12, 33 AND 50). SN 77-884,428. PUB. 1-18-2011. FILED 12-2-2009.

3,939,655. **ECO-CHOICE BY PLASTIBEC AND DESIGN**. PLASTIBEC INC., MULTIPLE CLASS, (INT. CLS. 19 AND 20), (U.S. CLS. 1, 2, 12, 13, 22, 25, 32, 33 AND 50). SN 77-922,739. PUB. 1-18-2011. FILED 1-28-2010.

3,939,682. **GENESIS (STANDARD CHARACTER)**. QEP - TENNESSEE, INC., (U.S. CLS. 1, 12, 33 AND 50). SN 77-929,007. PUB. 1-18-2011. FILED 2-5-2010.

3,939,701. **IN-VENT (STANDARD CHARACTER)**. COR-A-VENT, INC., (U.S. CLS. 1, 12, 33 AND 50). SN 77-932,502. PUB. 1-18-2011. FILED 2-10-2010.

3,939,772. **AKASHA (STANDARD CHARACTER)**. AKASHA, MULTIPLE CLASS, (INT. CLS. 19, 20 AND 21), (U.S. CLS. 1, 2, 12, 13, 22, 23, 25, 29, 30, 32, 33, 40 AND 50). SN 77-945,900. PUB. 1-18-2011. FILED 2-26-2010.

3,939,911 ( *See Class 6 for this trademark*).

3,939,977 ( *See Class 1 for this trademark*).

3,939,999 ( *See Class 6 for this trademark*).

3,940,038 ( *See Class 1 for this trademark*).

3,940,113. **GENESITE (STANDARD CHARACTER)**. CRYSTALGRIDTOOLS.COM LLC, (U.S. CLS. 1, 12, 33 AND 50). SN 85-016,584. PUB. 1-18-2011. FILED 4-18-2010.

3,940,114. **GODDESSITE (STANDARD CHARACTER)**. CRYSTALGRIDTOOLS.COM LLC, (U.S. CLS. 1, 12, 33 AND 50). SN 85-016,586. PUB. 1-18-2011. FILED 4-18-2010.

3,940,427. **CAL TRUSS (STANDARD CHARACTER)**. CALIFORNIA TRUSS COMPANY, (U.S. CLS. 1, 12, 33 AND 50). SN 85-096,202. PUB. 1-18-2011. FILED 7-29-2010.

3,940,856 ( *See Class 17 for this trademark*).

3,940,899. **KEYSTONE ESSENTIALS (STANDARD CHARACTER)**. KEYSTONE RETAINING WALL SYSTEMS, INC., (U.S. CLS. 1, 12, 33 AND 50). SN 85-114,600. PUB. 1-18-2011. FILED 8-24-2010.

## CLASS 20—FURNITURE AND ARTICLES NOT OTHERWISE CLASSIFIED

3,939,387. **COMFORT-AIRE (STANDARD CHARACTER)**. KENNEL-AIRE, LLC, (U.S. CLS. 2, 13, 22, 25, 32 AND 50). SN 76-704,031. PUB. 1-18-2011. FILED 8-5-2010.

3,939,490 ( *See Class 6 for this trademark*).

3,939,525 ( *See Class 7 for this trademark*).

3,939,529. **DELFIN (STANDARD CHARACTER)**. DELFIN DESIGN AND MANUFACTURING, INC., MULTIPLE CLASS, (INT. CLS. 20, 21 AND 40), (U.S. CLS. 2, 13, 22, 23, 25, 29, 30, 32, 33, 40, 50, 100, 103 AND 106). SN 77-809,498. PUB. 1-18-2011. FILED 8-20-2009.

3,939,531. **MISCELLANEOUS DESIGN**. DELFIN DESIGN AND MANUFACTURING, INC., MULTIPLE CLASS, (INT. CLS. 20, 21 AND 40), (U.S. CLS. 2, 13, 22, 23, 25, 29, 30, 32, 33, 40, 50, 100, 103 AND 106). SN 77-810,182. PUB. 1-18-2011. FILED 8-21-2009.

3,939,569 ( *See Class 6 for this trademark*).

3,939,613. **SWEET SPOTS (STYLIZED)**. CHAIRWORKS HOLDINGS INVESTMENT LIMITED, (U.S. CLS. 2, 13, 22, 25, 32 AND 50). SN 77-901,835. PUB. 1-18-2011. FILED 12-29-2009.

3,939,655 ( *See Class 19 for this trademark*).

3,939,661. **AHREND HUMANISING—SPACES AND DESIGN**. KONINKLIJKE AHREND N.V., MULTIPLE CLASS, (INT. CLS. 20, 37 AND 42), (U.S. CLS. 2, 13, 22, 25, 32, 50, 100, 101, 103 AND 106). SN 77-923,818. PUB. 1-18-2011. FILED 1-29-2010.

3,939,732. **ARQUATI AND DESIGN**. ARQUATI S.R.L., (U.S. CLS. 2, 13, 22, 25, 32 AND 50). SN 77-936,868. PUB. 1-18-2011. FILED 2-16-2010.

3,939,772 ( *See Class 19 for this trademark*).

3,939,830 ( *See Class 11 for this trademark*).

3,939,983 ( *See Class 11 for this trademark.*)  
 3,939,986 ( *See Class 11 for this trademark.*)  
 3,939,987 ( *See Class 11 for this trademark.*)  
 3,940,012. **UP ON (STYLIZED)**. IGAP SPA, (U.S. CLS. 2, 13, 22, 25, 32 AND 50). SN 79-082,555. PUB. 1-18-2011. FILED 3-30-2010.  
 3,940,015. **MISCELLANEOUS DESIGN**. OBSHCHESTVO S OGRANICHENNOY; OTVETSTVENNOSTYU; "MEBEL-NAYA FABRIKA MARIYA"; (MARIYA FURNITURE FACTORY LTD), MULTIPLE CLASS, (INT. CLS. 20 AND 35), (U.S. CLS. 2, 13, 22, 25, 32, 50, 100, 101 AND 102). SN 79-082,851. PUB. 1-18-2011. FILED 3-31-2010.  
 3,940,026 ( *See Class 14 for this trademark.*)  
 3,940,037. **RABENS ATELIER (STANDARD CHARACTER)**. RABENS ATELIER A/S, MULTIPLE CLASS, (INT. CLS. 20, 23 AND 35), (U.S. CLS. 2, 13, 22, 25, 32, 43, 50, 100, 101 AND 102). SN 79-084,817. PUB. 1-18-2011. FILED 4-9-2010.  
 3,940,044. **ASTRO BOUNCER (STANDARD CHARACTER)**. MAMAS & PAPAS (HOLDINGS) LIMITED, (U.S. CLS. 2, 13, 22, 25, 32 AND 50). SN 79-085,091. PUB. 1-18-2011. FILED 4-27-2010.  
 3,940,083 ( *See Class 12 for this trademark.*)  
 3,940,105. **MODEL MIRROR (STANDARD CHARACTER)**. 6 MINUTES LTD, DBA LES TAI TAI, (U.S. CLS. 2, 13, 22, 25, 32 AND 50). SN 85-013,585. PUB. 1-18-2011. FILED 4-14-2010.  
 3,940,313. **C COLLEGE PRODUCTS.COM AND DESIGN**. ERIC HENNING, DBA COLLEGE PRODUCTS INC., (U.S. CLS. 2, 13, 22, 25, 32 AND 50). SN 85-081,576. PUB. 1-18-2011. FILED 7-9-2010.  
 3,940,471. **G.E.A.R BY R-I GO! EVERYONE EVERYWHERE AND RE-INVENT AND DESIGN**. M. KELLIE GUTHRIE, (U.S. CLS. 2, 13, 22, 25, 32 AND 50). SN 85-097,414. PUB. 1-18-2011. FILED 7-30-2010.  
 3,940,796. **ZOOBIES (STANDARD CHARACTER)**. SMOOT BROTHERS IP HOLDING COMPANY, (U.S. CLS. 2, 13, 22, 25, 32 AND 50). SN 85-102,265. PUB. 1-18-2011. FILED 8-6-2010.  
 3,940,813. **MICHAEL WAINWRIGHT (STANDARD CHARACTER)**. MICHAEL WAINWRIGHT, INC, (U.S. CLS. 2, 13, 22, 25, 32 AND 50). SN 85-102,495. PUB. 1-18-2011. FILED 8-6-2010.  
 3,940,828. **NECKSPAWINGS (STYLIZED)**. PITTORE, NICOLE, DBA NECKSPAWINGS, (U.S. CLS. 2, 13, 22, 25, 32 AND 50). SN 85-102,624. PUB. 1-18-2011. FILED 8-8-2010.  
 3,940,907. **RPP CONTAINERS (STANDARD CHARACTER)**. DADCO, INC., (U.S. CLS. 2, 13, 22, 25, 32 AND 50). SN 85-116,112. PUB. 1-18-2011. FILED 8-26-2010.  
 3,940,923 ( *See Class 18 for this trademark.*)  
 3,940,939. **PERI (STANDARD CHARACTER)**. CHF INDUSTRIES INC., MULTIPLE CLASS, (INT. CLS. 20, 21, 24 AND 27), (U.S. CLS. 2, 13, 19, 20, 22, 23, 25, 29, 30, 32, 33, 37, 40, 42 AND 50). SN 85-128,244. PUB. 1-18-2011. FILED 9-13-2010.

---

## CLASS 21—HOUSEWARES AND GLASS

3,939,529 ( *See Class 20 for this trademark.*)  
 3,939,531 ( *See Class 20 for this trademark.*)  
 3,939,562 ( *See Class 4 for this trademark.*)  
 3,939,569 ( *See Class 6 for this trademark.*)  
 3,939,629 ( *See Class 3 for this trademark.*)  
 3,939,635. **CHARTIS (STANDARD CHARACTER)**. AKITA, INC., (U.S. CLS. 2, 13, 23, 29, 30, 33, 40 AND 50). SN 77-916,640. PUB. 1-18-2011. FILED 1-21-2010.  
 3,939,647. **LIBRE AND DESIGN**. FEMININE ENERGETICS INC., (U.S. CLS. 2, 13, 23, 29, 30, 33, 40 AND 50). SN 77-920,635. PUB. 1-18-2011. FILED 1-26-2010.  
 3,939,648. **ECO GROUNDS (STANDARD CHARACTER)**. JAVA CITY, INC., MULTIPLE CLASS, (INT. CLS. 21 AND 43), (U.S. CLS. 2, 13, 23, 29, 30, 33, 40, 50, 100 AND 101). SN 77-921,694. PUB. 1-18-2011. FILED 1-27-2010.  
 3,939,772 ( *See Class 19 for this trademark.*)  
 3,939,793. **CAPELLA COLLECTION AND DESIGN**. CAPELLA COLLECTION LLC, DBA CAPELLA COLLECTION, (U.S. CLS. 2, 13, 23, 29, 30, 33, 40 AND 50). SN 77-951,456. PUB. 1-18-2011. FILED 3-5-2010.  
 3,939,882 ( *See Class 8 for this trademark.*)

3,939,903 ( *See Class 8 for this trademark.*)  
 3,939,905 ( *See Class 8 for this trademark.*)  
 3,939,913 ( *See Class 3 for this trademark.*)  
 3,939,983 ( *See Class 11 for this trademark.*)  
 3,939,986 ( *See Class 11 for this trademark.*)  
 3,939,987 ( *See Class 11 for this trademark.*)  
 3,940,000 ( *See Class 3 for this trademark.*)  
 3,940,042 ( *See Class 3 for this trademark.*)  
 3,940,048. **LUXFOIL (STYLIZED)**. YONWOO CO.,LTD, (U.S. CLS. 2, 13, 23, 29, 30, 33, 40 AND 50). SN 79-085,359. PUB. 1-18-2011. FILED 6-16-2010.  
 3,940,146 ( *See Class 18 for this trademark.*)  
 3,940,199 ( *See Class 4 for this trademark.*)  
 3,940,265 ( *See Class 9 for this trademark.*)  
 3,940,283 ( *See Class 9 for this trademark.*)  
 3,940,317. **MISCELLANEOUS DESIGN**. K-9 ENTERPRISES, LLC, (U.S. CLS. 2, 13, 23, 29, 30, 33, 40 AND 50). SN 85-082,092. PUB. 1-18-2011. FILED 7-11-2010.  
 3,940,324. **AMERICAN CRAFT ORIGINALS (STANDARD CHARACTER)**. THE LONGBERGER COMPANY, (U.S. CLS. 2, 13, 23, 29, 30, 33, 40 AND 50). SN 85-083,079. PUB. 1-18-2011. FILED 7-13-2010.  
 3,940,396 ( *See Class 14 for this trademark.*)  
 3,940,459. **M AND DESIGN**. CHATEAU MORRISSETTE, INC., MULTIPLE CLASS, (INT. CLS. 21 AND 33), (U.S. CLS. 2, 13, 23, 29, 30, 33, 40, 47, 49 AND 50). SN 85-097,277. PUB. 1-18-2011. FILED 7-30-2010.  
 3,940,488. **FJH (STYLIZED)**. HORVATH, FRANK JERRY, (U.S. CLS. 2, 13, 23, 29, 30, 33, 40 AND 50). SN 85-097,574. PUB. 1-18-2011. FILED 7-31-2010.  
 3,940,521. **THE ORIGINAL BEACH BAND-IT (STANDARD CHARACTER)**. SCHAEFFER, DON, (U.S. CLS. 2, 13, 23, 29, 30, 33, 40 AND 50). SN 85-098,106. PUB. 1-18-2011. FILED 8-2-2010.  
 3,940,534. **PROFESSIONAL PLATINUM COOKING SYSTEM (STANDARD CHARACTER)**. KELLNER, SAVILLE, (U.S. CLS. 2, 13, 23, 29, 30, 33, 40 AND 50). SN 85-098,385. PUB. 1-18-2011. FILED 8-2-2010.  
 3,940,680. **JAKON AND DESIGN**. ZHEJIANG JIAKANG STAINLESS STEEL PRODUCT CO.,LTD., (U.S. CLS. 2, 13, 23, 29, 30, 33, 40 AND 50). SN 85-100,576. PUB. 1-18-2011. FILED 8-5-2010.  
 3,940,683. **MORNING BEAUTY AND DESIGN**. JINAN DIOR GLASS PRODUCT CO., LTD., (U.S. CLS. 2, 13, 23, 29, 30, 33, 40 AND 50). SN 85-100,597. PUB. 1-18-2011. FILED 8-5-2010.  
 3,940,771 ( *See Class 11 for this trademark.*)  
 3,940,795. **CHEFSMART (STANDARD CHARACTER)**. CHEFSMART, INC., (U.S. CLS. 2, 13, 23, 29, 30, 33, 40 AND 50). SN 85-102,247. PUB. 1-18-2011. FILED 8-6-2010.  
 3,940,812. **MICHAEL WAINWRIGHT (STANDARD CHARACTER)**. MICHAEL WAINWRIGHT, INC, (U.S. CLS. 2, 13, 23, 29, 30, 33, 40 AND 50). SN 85-102,492. PUB. 1-18-2011. FILED 8-6-2010.  
 3,940,814. **MICHAEL WAINWRIGHT (STANDARD CHARACTER)**. MICHAEL WAINWRIGHT, INC, (U.S. CLS. 2, 13, 23, 29, 30, 33, 40 AND 50). SN 85-102,496. PUB. 1-18-2011. FILED 8-6-2010.  
 3,940,860. **MICHAEL WAINWRIGHT (STANDARD CHARACTER)**. MICHAEL WAINWRIGHT, INC, (U.S. CLS. 2, 13, 23, 29, 30, 33, 40 AND 50). SN 85-103,677. PUB. 1-18-2011. FILED 8-9-2010.  
 3,940,939 ( *See Class 20 for this trademark.*)  
 3,940,949 ( *See Class 9 for this trademark.*)

---

## CLASS 22—CORDAGE AND FIBERS

3,939,733. **ARQUATI AND DESIGN**. ARQUATI S.R.L., (U.S. CLS. 1, 2, 7, 19, 22, 42 AND 50). SN 77-936,881. PUB. 1-18-2011. FILED 2-16-2010.  
 3,940,033 ( *See Class 5 for this trademark.*)  
 3,940,301 ( *See Class 12 for this trademark.*)

**CLASS 23—YARNS AND THREADS**

- 3,939,510. **VANNA'S GLAMOUR (STANDARD CHARACTER)**. ORCHARD YARN AND THREAD COMPANY, INC., DBA LION BRAND YARN COMPANY, (U.S. CL. 43). SN 77-791,898. PUB. 1-18-2011. FILED 7-29-2009.
- 3,939,609. **EL-GATO (STANDARD CHARACTER)**. COLOMER, S.A. DE C.V., (U.S. CL. 43). SN 77-900,123. PUB. 1-18-2011. FILED 12-23-2009.
- 3,940,037 ( *See Class 20 for this trademark*).
- 3,940,532. **SPUN-TREL (STANDARD CHARACTER)**. KOMAR ALLIANCE, LLC, (U.S. CL. 43). SN 85-098,369. PUB. 1-18-2011. FILED 8-2-2010.

**CLASS 24—FABRICS**

- 3,939,355. **JACKSON STATE UNIVERSITY (STANDARD CHARACTER)**. JACKSON STATE UNIVERSITY, MULTIPLE CLASS, (INT. CLS. 24, 27 AND 32), (U.S. CLS. 19, 20, 37, 42, 45, 46, 48 AND 50). SN 76-699,475. PUB. 1-18-2011. FILED 9-14-2009.
- 3,939,567. **MISCELLANEOUS DESIGN**. NEW YORK YACHT CLUB, MULTIPLE CLASS, (INT. CLS. 24, 41 AND 43), (U.S. CLS. 42, 50, 100, 101 AND 107). SN 77-854,160. PUB. 1-18-2011. FILED 10-21-2009.
- 3,939,895 ( *See Class 9 for this trademark*).
- 3,939,931 ( *See Class 14 for this trademark*).
- 3,939,995 ( *See Class 18 for this trademark*).
- 3,940,009 ( *See Class 1 for this trademark*).
- 3,940,029 ( *See Class 3 for this trademark*).
- 3,940,140. **MISCELLANEOUS DESIGN**. DUKE IMPORTS, INC., (U.S. CLS. 42 AND 50). SN 85-029,264. PUB. 1-18-2011. FILED 5-3-2010.
- 3,940,146 ( *See Class 18 for this trademark*).
- 3,940,228 ( *See Class 6 for this trademark*).
- 3,940,336 ( *See Class 16 for this trademark*).
- 3,940,396 ( *See Class 14 for this trademark*).
- 3,940,478. **BAMBOO BARE AND DESIGN**. BAMBOO BARE, INC., (U.S. CLS. 42 AND 50). SN 85-097,465. PUB. 1-18-2011. FILED 7-31-2010.
- 3,940,630. **SUITE SOLUTIONS (STANDARD CHARACTER)**. THE ROBERT ALLEN GROUP, MULTIPLE CLASS, (INT. CLS. 24 AND 35), (U.S. CLS. 42, 50, 100, 101 AND 102). SN 85-099,960. PUB. 1-18-2011. FILED 8-4-2010.
- 3,940,923 ( *See Class 18 for this trademark*).
- 3,940,939 ( *See Class 20 for this trademark*).

**CLASS 25—CLOTHING**

- 3,939,361. **ASHLEY SPORT (STANDARD CHARACTER)**. AS IP HOLDINGS, INC., (U.S. CLS. 22 AND 39). SN 76-701,488. PUB. 1-18-2011. FILED 2-4-2010.
- 3,939,365. **BARI BEEF (STANDARD CHARACTER)**. BOB'S BETTER BEEF, INC, (U.S. CLS. 22 AND 39). SN 76-701,745. PUB. 1-18-2011. FILED 2-22-2010.
- 3,939,393. **FALL OUT BOY (STANDARD CHARACTER)**. FALL OUT BOY, INC., (U.S. CLS. 22 AND 39). SN 77-083,160. PUB. 1-18-2011. FILED 1-15-2007.
- 3,939,396. **WENGER (STANDARD CHARACTER)**. WENGER S.A., (U.S. CLS. 22 AND 39). SN 77-119,470. PUB. 1-18-2011. FILED 3-1-2007.
- 3,939,400 ( *See Class 5 for this trademark*).
- 3,939,405 ( *See Class 9 for this trademark*).
- 3,939,449 ( *See Class 18 for this trademark*).
- 3,939,462. **U.S. OPEN POLO CHAMPIONSHIP (STANDARD CHARACTER)**. UNITED STATES POLO ASSOCIATION, (U.S. CLS. 22 AND 39). SN 77-700,241. PUB. 1-18-2011. FILED 3-26-2009.
- 3,939,466 ( *See Class 16 for this trademark*).
- 3,939,485. **SMART STRAP (STANDARD CHARACTER)**. SUNDAY AFTERNOONS INC, (U.S. CLS. 22 AND 39). SN 77-748,789. PUB. 1-18-2011. FILED 6-1-2009.
- 3,939,491. **MISCELLANEOUS DESIGN**. LUCASFILM ENTERTAINMENT COMPANY LTD., MULTIPLE CLASS, (INT.

- CLS. 25 AND 28), (U.S. CLS. 22, 23, 38, 39 AND 50). SN 77-762,433. PUB. 1-18-2011. FILED 6-17-2009.
- 3,939,500. **MISCELLANEOUS DESIGN**. PANDA RHAND LLC, (U.S. CLS. 22 AND 39). SN 77-781,863. PUB. 1-18-2011. FILED 7-15-2009.
- 3,939,514 ( *See Class 18 for this trademark*).
- 3,939,548 ( *See Class 18 for this trademark*).
- 3,939,557. **YNGWIE MALMSTEEN (STANDARD CHARACTER)**. YNGWIE MALMSTEEN, AND APRIL MALMSTEEN, (U.S. CLS. 22 AND 39). SN 77-846,725. PUB. 1-18-2011. FILED 10-12-2009.
- 3,939,569 ( *See Class 6 for this trademark*).
- 3,939,578. **HAWKINS SPORT (STANDARD CHARACTER)**. ABC-MART, INC., (U.S. CLS. 22 AND 39). SN 77-867,874. PUB. 1-18-2011. FILED 11-9-2009.
- 3,939,588. **RELIGIOUS COMFORT (STANDARD CHARACTER)**. 2135036 ONTARIO LIMITED, (U.S. CLS. 22 AND 39). SN 77-877,465. PUB. 1-18-2011. FILED 11-20-2009.
- 3,939,591 ( *See Class 9 for this trademark*).
- 3,939,597. **D AND DESIGN**. TECNICA S.P.A., (U.S. CLS. 22 AND 39). SN 77-885,352. PUB. 1-18-2011. FILED 12-3-2009.
- 3,939,605. **80'S BABY (STYLIZED)**. HARRY LUM, (U.S. CLS. 22 AND 39). SN 77-894,927. PUB. 1-18-2011. FILED 12-16-2009.
- 3,939,610. **BAR MAGIC OF DENIM (STANDARD CHARACTER)**. PATRICK CHEMOUL, (U.S. CLS. 22 AND 39). SN 77-901,417. PUB. 1-18-2011. FILED 12-28-2009.
- 3,939,629 ( *See Class 3 for this trademark*).
- 3,939,636. **ULTRASOFTS (STANDARD CHARACTER)**. NATIONAL WHOLESALE COMPANY, INC., (U.S. CLS. 22 AND 39). SN 77-917,152. PUB. 1-18-2011. FILED 1-21-2010.
- 3,939,645. **PHOENIXSERIES (STANDARD CHARACTER)**. PERFECTION UNIFORMS, LLC, (U.S. CLS. 22 AND 39). SN 77-920,015. PUB. 1-18-2011. FILED 1-26-2010.
- 3,939,673. **THE WORLD IS OURS (STANDARD CHARACTER)**. HARRY LUM, (U.S. CLS. 22 AND 39). SN 77-927,546. PUB. 1-18-2011. FILED 2-3-2010.
- 3,939,702. **EXCLUSIVE BRIDALS (STANDARD CHARACTER)**. ALLURE BRIDALS, INC., (U.S. CLS. 22 AND 39). SN 77-932,726. PUB. 1-18-2011. FILED 2-10-2010.
- 3,939,704. **Z ZUNGUI AND DESIGN**. MENGSHIDA SHOES CO., LTD.SHISHI CITY, (U.S. CLS. 22 AND 39). SN 77-933,181. PUB. 1-18-2011. FILED 2-11-2010.
- 3,939,706. **REBEL ROOTS AND DESIGN**. NATHAN AMAR, (U.S. CLS. 22 AND 39). SN 77-933,718. PUB. 1-18-2011. FILED 2-11-2010.
- 3,939,711. **POOR BROKE & HANDSOM (STANDARD CHARACTER)**. POOR, BROKE, & HANDSOM INC., (U.S. CLS. 22 AND 39). SN 77-935,163. PUB. 1-18-2011. FILED 2-12-2010.
- 3,939,736. **PRETTY AND PRIVILEGED (STANDARD CHARACTER)**. TRACY IGWE, DBA PRETTY AND PRIVILEGED, AND LAUREN SANDERS, DBA PRETTY AND PRIVILEGED, (U.S. CLS. 22 AND 39). SN 77-937,059. PUB. 1-18-2011. FILED 2-16-2010.
- 3,939,747 ( *See Class 16 for this trademark*).
- 3,939,750. **WORLD'S GREATEST AIRCRAFT COLLECTION (STANDARD CHARACTER)**. KW INTELLECTUAL PROPERTIES, INC., MULTIPLE CLASS, (INT. CLS. 25 AND 41), (U.S. CLS. 22, 39, 100, 101 AND 107). SN 77-939,982. PUB. 1-18-2011. FILED 2-19-2010.
- 3,939,759. **SPIRIT HOODS (STANDARD CHARACTER)**. SPIRIT HOODS LLC, (U.S. CLS. 22 AND 39). SN 77-941,921. PUB. 1-18-2011. FILED 2-22-2010.
- 3,939,784. **ERIN MURPHY (STANDARD CHARACTER)**. SMITH, R. LELAND B., JR., AND MURPHY, ERIN L., (U.S. CLS. 22 AND 39). SN 77-949,824. PUB. 1-18-2011. FILED 3-3-2010.
- 3,939,786. **SKYE SO SOFT FABRIC (STYLIZED)**. SGS SPORTS INC., (U.S. CLS. 22 AND 39). SN 77-950,314. PUB. 1-18-2011. FILED 3-4-2010.
- 3,939,834. **MISCELLANEOUS DESIGN**. REMEY ROZIN, (U.S. CLS. 22 AND 39). SN 77-963,678. PUB. 1-18-2011. FILED 3-19-2010.
- 3,939,843. **SOUTHERN BELLE ORIGINALS AND DESIGN**. SOUTHERN BELLE ORIGINALS, INC., (U.S. CLS. 22 AND 39). SN 77-965,089. PUB. 1-18-2011. FILED 3-22-2010.
- 3,939,866. **WARRIOR (STYLIZED)**. WARRIOR LACROSSE, INC., (U.S. CLS. 22 AND 39). SN 78-486,173. PUB. 12-26-2006.

- FILED 9-20-2004.  
 3,939,867. **WARRIOR (STYLIZED)**. WARRIOR LACROSSE, INC., (U.S. CLS. 22 AND 39). SN 78-486,210. PUB. 12-26-2006. FILED 9-20-2004.  
 3,939,868. **IT'S FIVE O'CLOCK SOMEWHERE (STANDARD CHARACTER)**. JB INTELLECTUAL PROPERTY, LLC, (U.S. CLS. 22 AND 39). SN 78-597,514. PUB. 1-18-2011. FILED 3-29-2005.  
 3,939,873. **SOUL OF AFRICA (STANDARD CHARACTER)**. SOUL OF AFRICA, (U.S. CLS. 22 AND 39). SN 78-811,030. PUB. 1-18-2011. FILED 2-9-2006.  
 3,939,886 ( *See Class 18 for this trademark*).  
 3,939,890 ( *See Class 9 for this trademark*).  
 3,939,895 ( *See Class 9 for this trademark*).  
 3,939,908. **SK AND DESIGN**. OBSCHESTVO SOGRANICHENNOI; OTVETSTVENNOSTIU "EKSITOM", MULTIPLE CLASS, (INT. CLS. 25 AND 35), (U.S. CLS. 22, 39, 100, 101 AND 102). SN 79-073,768. PUB. 1-18-2011. FILED 5-27-2009.  
 3,939,913 ( *See Class 3 for this trademark*).  
 3,939,919 ( *See Class 18 for this trademark*).  
 3,939,922 ( *See Class 14 for this trademark*).  
 3,939,931 ( *See Class 14 for this trademark*).  
 3,939,934 ( *See Class 18 for this trademark*).  
 3,939,936 ( *See Class 3 for this trademark*).  
 3,939,953. **FISH MARKET AND DESIGN**. SAPO....X SAS DI CHIARA RONDONI & C., (U.S. CLS. 22 AND 39). SN 79-080,142. PUB. 1-18-2011. FILED 1-13-2010.  
 3,939,954 ( *See Class 12 for this trademark*).  
 3,939,955 ( *See Class 12 for this trademark*).  
 3,939,956. **AGNEAU AND DESIGN**. KIM SUN KYUNG, (U.S. CLS. 22 AND 39). SN 79-080,298. PUB. 10-12-2010. FILED 1-19-2010.  
 3,939,967. **MISCELLANEOUS DESIGN**. CAMPUS LIVING VILLAGES; PTY LIMITED, MULTIPLE CLASS, (INT. CLS. 25, 35, 36, 37 AND 43), (U.S. CLS. 22, 39, 100, 101, 102, 103 AND 106). SN 79-080,583. PUB. 1-18-2011. FILED 2-9-2010.  
 3,939,995 ( *See Class 18 for this trademark*).  
 3,940,002 ( *See Class 12 for this trademark*).  
 3,940,009 ( *See Class 1 for this trademark*).  
 3,940,021 ( *See Class 9 for this trademark*).  
 3,940,024 ( *See Class 18 for this trademark*).  
 3,940,025. **MES DENIMS BY CATIMINI (STYLIZED)**. CATIMINI, (U.S. CLS. 22 AND 39). SN 79-083,774. PUB. 1-18-2011. FILED 5-31-2010.  
 3,940,026 ( *See Class 14 for this trademark*).  
 3,940,027 ( *See Class 18 for this trademark*).  
 3,940,029 ( *See Class 3 for this trademark*).  
 3,940,033 ( *See Class 5 for this trademark*).  
 3,940,039. **DR. MARTENS DR. MARTENS AND DESIGN**. "DR. MARTENS" INTERNATIONAL TRADING GMBH, AND "DR. MAERTENS" MARKETING GMBH, (U.S. CLS. 22 AND 39). SN 79-084,950. PUB. 1-18-2011. FILED 6-1-2010.  
 3,940,040 ( *See Class 3 for this trademark*).  
 3,940,076. **MONCLER FOR EVERYTHING ABOVE SEA LEVEL (STANDARD CHARACTER)**. MONCLER S.R.L., (U.S. CLS. 22 AND 39). SN 79-089,052. PUB. 1-18-2011. FILED 4-26-2010.  
 3,940,083 ( *See Class 12 for this trademark*).  
 3,940,090. **JCLU FOREVER (STANDARD CHARACTER)**. LOUIS FONG, DBA JCLU FOREVER, AND KIMBERLY FONG, DBA JCLU FOREVER, (U.S. CLS. 22 AND 39). SN 85-005,907. PUB. 1-18-2011. FILED 4-5-2010.  
 3,940,098. **JCLU (STANDARD CHARACTER)**. LOUIS FONG, DBA JCLU FOREVER, AND KIMBERLY FONG, DBA JCLU FOREVER, (U.S. CLS. 22 AND 39). SN 85-010,788. PUB. 1-18-2011. FILED 4-9-2010.  
 3,940,135. **AMOEBA CLOTHING AND DESIGN**. AMY WITTE, DBA AMOEBA CLOTHING, (U.S. CLS. 22 AND 39). SN 85-028,768. PUB. 10-12-2010. FILED 5-3-2010.  
 3,940,149. **THE SPORTING LIFE (STANDARD CHARACTER)**. JL POWELL LLC, (U.S. CLS. 22 AND 39). SN 85-032,940. PUB. 1-18-2011. FILED 5-7-2010.  
 3,940,153 ( *See Class 12 for this trademark*).  
 3,940,160. **L L AND DESIGN**. LANDAU UNIFORMS, INCORPORATED, (U.S. CLS. 22 AND 39). SN 85-036,715. PUB. 10-12-2010. FILED 5-12-2010.  
 3,940,195 ( *See Class 16 for this trademark*).  
 3,940,200. **BURANA (STYLIZED)**. CALCADOS MYRABEL LTDA., (U.S. CLS. 22 AND 39). SN 85-048,967. PUB. 1-18-2011. FILED 5-27-2010.  
 3,940,205. **EPIDEMIC (STANDARD CHARACTER)**. DYSLEXIC LAB LLC, DBA DYSLEXIC LAB LLC, (U.S. CLS. 22 AND 39). SN 85-050,807. PUB. 1-18-2011. FILED 5-28-2010.  
 3,940,219. **N AND DESIGN**. HASBRO, INC., (U.S. CLS. 22 AND 39). SN 85-055,839. PUB. 10-12-2010. FILED 6-7-2010.  
 3,940,239. **MARSHALL AMPLIFICATION (STYLIZED)**. MARSHALL AMPLIFICIATION PLC, (U.S. CLS. 22 AND 39). SN 85-060,747. PUB. 1-18-2011. FILED 6-11-2010.  
 3,940,265 ( *See Class 9 for this trademark*).  
 3,940,280. **BLACK BERETS DEFENSE & FITNESS BEYOND VALOR AND DESIGN**. BLACK BERETS DEFENSE & FITNESS ACADEMY, L.L.C., MULTIPLE CLASS, (INT. CLS. 25 AND 41), (U.S. CLS. 22, 39, 100, 101 AND 107). SN 85-072,482. PUB. 1-18-2011. FILED 6-27-2010.  
 3,940,284. **PINK REPUBLIC (STANDARD CHARACTER)**. GREEN ROCK FASHION, INC, (U.S. CLS. 22 AND 39). SN 85-073,490. PUB. 1-18-2011. FILED 6-29-2010.  
 3,940,285. **STOL (STYLIZED)**. HUMBERTO RUBIO & ASSOCIATES, L.L.C., (U.S. CLS. 22 AND 39). SN 85-073,954. PUB. 1-18-2011. FILED 6-29-2010.  
 3,940,336 ( *See Class 16 for this trademark*).  
 3,940,341 ( *See Class 16 for this trademark*).  
 3,940,342. **MILK & COOKIES CLOTHING COMPANY (STANDARD CHARACTER)**. ROBERT CISHECKI, DBA MILK & COOKIES CLOTHING COMPANY, (U.S. CLS. 22 AND 39). SN 85-086,812. PUB. 1-18-2011. FILED 7-16-2010.  
 3,940,346. **CYBEROPTIX (STANDARD CHARACTER)**. CYBEROPTIX, LLC, MULTIPLE CLASS, (INT. CLS. 25 AND 41), (U.S. CLS. 22, 39, 100, 101 AND 107). SN 85-087,565. PUB. 1-18-2011. FILED 7-19-2010.  
 3,940,376. **MB (STYLIZED)**. MYRTLE BEACH PELICANS LP, (U.S. CLS. 22 AND 39). SN 85-091,744. PUB. 1-18-2011. FILED 7-23-2010.  
 3,940,396 ( *See Class 14 for this trademark*).  
 3,940,435. **CHOOSE HOPE (STANDARD CHARACTER)**. CHOOSE HOPE INC., (U.S. CLS. 22 AND 39). SN 85-096,545. PUB. 1-18-2011. FILED 7-30-2010.  
 3,940,441. **KALI WARRIOR AND DESIGN**. THOMPSON, BUD, MULTIPLE CLASS, (INT. CLS. 25 AND 41), (U.S. CLS. 22, 39, 100, 101 AND 107). SN 85-096,642. PUB. 1-18-2011. FILED 7-30-2010.  
 3,940,457. **M AND DESIGN**. CHATEAU MORRISSETTE, INC., (U.S. CLS. 22 AND 39). SN 85-097,234. PUB. 1-18-2011. FILED 7-30-2010.  
 3,940,464. **D AND DESIGN**. FORTUNE DYNAMIC INC., (U.S. CLS. 22 AND 39). SN 85-097,337. PUB. 1-18-2011. FILED 7-30-2010.  
 3,940,465. **WOW LOOKZ MADE IN USA (STYLIZED)**. EXPRESS SOURCE, INC., (U.S. CLS. 22 AND 39). SN 85-097,347. PUB. 1-18-2011. FILED 7-30-2010.  
 3,940,540. **MISCELLANEOUS DESIGN**. STEART CLOTHING COMPANY LLC, (U.S. CLS. 22 AND 39). SN 85-098,469. PUB. 1-18-2011. FILED 8-2-2010.  
 3,940,569. **TAILS UP (STANDARD CHARACTER)**. CROCKTAIL LLC, (U.S. CLS. 22 AND 39). SN 85-098,866. PUB. 1-18-2011. FILED 8-3-2010.  
 3,940,596. **KINGS OF LEON (STANDARD CHARACTER)**. FOLLOWILL MUSIC, INC., (U.S. CLS. 22 AND 39). SN 85-099,415. PUB. 1-18-2011. FILED 8-3-2010.  
 3,940,605. **ASPOP (STYLIZED)**. SHANDONG JIANGCHEN GARMENT CO.,LTD., (U.S. CLS. 22 AND 39). SN 85-099,634. PUB. 1-18-2011. FILED 8-4-2010.  
 3,940,613. **STRICTLY FOR YOU AND DESIGN**. PAUTIN, REYNALDO, AND VAILLEAU, PHILIPPE, AND VAILLEAU, MARIA CLARA PAUTIN GANTAN, (U.S. CLS. 22 AND 39). SN 85-099,745. PUB. 1-18-2011. FILED 8-4-2010.  
 3,940,620. **SKIPOLINI'S (STANDARD CHARACTER)**. SKIPOPOLINI'S INC., MULTIPLE CLASS, (INT. CLS. 25, 39 AND 43), (U.S. CLS. 22, 39, 100, 101 AND 105). SN 85-099,808. PUB. 1-18-2011. FILED 8-4-2010.  
 3,940,621. **SKIPOLINI'S PIZZA AND DESIGN**. SKIPOLINI'S INC., MULTIPLE CLASS, (INT. CLS. 25, 39 AND 43), (U.S. CLS. 22, 39, 100, 101 AND 105). SN 85-099,839. PUB. 1-18-2011. FILED 8-4-2010.  
 3,940,681. **MOUNTAIN JUNKIE (STANDARD CHARACTER)**.

INCOGNITO INCORPORATED, (U.S. CLS. 22 AND 39). SN 85-100,586. PUB. 1-18-2011. FILED 8-5-2010.

3,940,694. **MARC TULIO (STANDARD CHARACTER)**. GIORGIO COSANI, INC., (U.S. CLS. 22 AND 39). SN 85-100,771. PUB. 1-18-2011. FILED 8-5-2010.

3,940,695. **POCKETBOOK (STANDARD CHARACTER)**. MILK MONEY CLOTHING, INC., (U.S. CLS. 22 AND 39). SN 85-100,772. PUB. 1-18-2011. FILED 8-5-2010.

3,940,740. **ILLUSTRATOR (STANDARD CHARACTER)**. EXPRESS, LLC, (U.S. CLS. 22 AND 39). SN 85-101,369. PUB. 1-18-2011. FILED 8-5-2010.

3,940,742. **THE HOUR (STYLIZED)**. YOUNUS, ZESHAAN, (U.S. CLS. 22 AND 39). SN 85-101,442. PUB. 1-18-2011. FILED 8-5-2010.

3,940,746. **DO STUFF...NAKED AND DESIGN**. MESSER, MARGARET, (U.S. CLS. 22 AND 39). SN 85-101,461. PUB. 1-18-2011. FILED 8-5-2010.

3,940,747. **BLESSED LIFE (STANDARD CHARACTER)**. SHARON LYNN CAMPBELL, LLC, (U.S. CLS. 22 AND 39). SN 85-101,487. PUB. 1-18-2011. FILED 8-5-2010.

3,940,753. **MOMMIES HUNT TOO! AND DESIGN**. RANGEL, RANDY, (U.S. CLS. 22 AND 39). SN 85-101,525. PUB. 1-18-2011. FILED 8-5-2010.

3,940,758. **PEE HAPPY AND DESIGN**. COBOS, LUCY, DBA PEE HAPPY, (U.S. CLS. 22 AND 39). SN 85-101,561. PUB. 1-18-2011. FILED 8-5-2010.

3,940,767. **STYLIST (STANDARD CHARACTER)**. EXPRESS, LLC, (U.S. CLS. 22 AND 39). SN 85-101,782. PUB. 1-18-2011. FILED 8-6-2010.

3,940,797. **LATTITUDE 33 (STANDARD CHARACTER)**. RIFF, JONATHAN, (U.S. CLS. 22 AND 39). SN 85-102,287. PUB. 1-18-2011. FILED 8-6-2010.

3,940,808. **JOCKSTRAP QUEEN (STANDARD CHARACTER)**. SUSAN BOYER, (U.S. CLS. 22 AND 39). SN 85-102,433. PUB. 1-18-2011. FILED 8-6-2010.

3,940,809. **BOOMIN BRUIN (STANDARD CHARACTER)**. HROMADKA, MARK, AND HROMADKA, TAMMY, (U.S. CLS. 22 AND 39). SN 85-102,446. PUB. 1-18-2011. FILED 8-6-2010.

3,940,815. **SPIREDANCE AND DESIGN**. SHIH, JARED J., (U.S. CLS. 22 AND 39). SN 85-102,510. PUB. 1-18-2011. FILED 8-7-2010.

3,940,825 ( *See Class 14 for this trademark*).

3,940,832. **JUMP ON THE MONKEY (STANDARD CHARACTER)**. INGEGAR FASHIONS, INC., (U.S. CLS. 22 AND 39). SN 85-102,696. PUB. 1-18-2011. FILED 8-8-2010.

3,940,837. **GET NAILED (STANDARD CHARACTER)**. RAMOS, MANUEL, (U.S. CLS. 22 AND 39). SN 85-103,078. PUB. 1-18-2011. FILED 8-9-2010.

3,940,872. **IN FREEDOM WE TRUST (STANDARD CHARACTER)**. TILLMANN, CAMERON LEE, (U.S. CLS. 22 AND 39). SN 85-108,432. PUB. 1-18-2011. FILED 8-16-2010.

3,940,873. **FREEDOM CLOTHING (STYLIZED)**. TILLMANN, CAMERON LEE, (U.S. CLS. 22 AND 39). SN 85-108,551. PUB. 1-18-2011. FILED 8-16-2010.

3,940,881. **SPEREL (STANDARD CHARACTER)**. SPELLMAN, ORION, (U.S. CLS. 22 AND 39). SN 85-109,898. PUB. 1-18-2011. FILED 8-17-2010.

3,940,894. **RAISED FIST (STANDARD CHARACTER)**. RAISED FIST INC., (U.S. CLS. 22 AND 39). SN 85-112,382. PUB. 1-18-2011. FILED 8-20-2010.

3,940,914. **GREAT AMERICAN CIRCUS AND DESIGN**. CIRQUE POLYNESIA MAUI, LLC, MULTIPLE CLASS, (INT. CLS. 25 AND 41), (U.S. CLS. 22, 39, 100, 101 AND 107). SN 85-118,131. PUB. 1-18-2011. FILED 8-28-2010.

3,940,934. **MANIC PANIC (STYLIZED)**. TISH & SNOOKY'S N.Y.C. INC., (U.S. CLS. 22 AND 39). SN 85-127,600. PUB. 1-18-2011. FILED 9-11-2010.

3,940,944. **MISCELLANEOUS DESIGN**. MARK THOMAS OLIVER, DBA BODY BY YOGA, (U.S. CLS. 22 AND 39). SN 85-129,585. PUB. 1-18-2011. FILED 9-14-2010.

3,940,950 ( *See Class 18 for this trademark*).

3,940,972. **LIVE LIFE PLAY AND DESIGN**. DESMARAIS, BRENDA, (U.S. CLS. 22 AND 39). SN 85-161,415. PUB. 1-18-2011. FILED 10-26-2010.

3,940,974. **SHIGI (STANDARD CHARACTER)**. ROYCE TOO LLC, (U.S. CLS. 22 AND 39). SN 85-975,005. PUB. 1-18-2011. FILED 5-14-2010.

**CLASS 26—FANCY GOODS**

3,939,919 ( *See Class 18 for this trademark*).

3,940,029 ( *See Class 3 for this trademark*).

3,940,265 ( *See Class 9 for this trademark*).

3,940,415. **GMI (STYLIZED)**. GREEN MANUFACTURING INTERNATIONAL LIMITED, (U.S. CLS. 37, 39, 40, 42 AND 50). SN 85-095,449. PUB. 1-18-2011. FILED 7-29-2010.

3,940,714. **ALL IN (STANDARD CHARACTER)**. BEAUTY ELEMENTS CORP., (U.S. CLS. 37, 39, 40, 42 AND 50). SN 85-100,981. PUB. 1-18-2011. FILED 8-5-2010.

3,940,716. **VIVIAN (STANDARD CHARACTER)**. BEAUTY ELEMENTS CORP., (U.S. CLS. 37, 39, 40, 42 AND 50). SN 85-100,991. PUB. 1-18-2011. FILED 8-5-2010.

3,940,719. **XTRA (STANDARD CHARACTER)**. BEAUTY ELEMENTS CORP., (U.S. CLS. 37, 39, 40, 42 AND 50). SN 85-101,000. PUB. 1-18-2011. FILED 8-5-2010.

3,940,933. **MANIC PANIC (STYLIZED)**. TISH & SNOOKY'S N.Y.C. INC., (U.S. CLS. 37, 39, 40, 42 AND 50). SN 85-127,598. PUB. 1-18-2011. FILED 9-11-2010.

**CLASS 27—FLOOR COVERINGS**

3,939,355 ( *See Class 24 for this trademark*).

3,939,897. **COOLPLUS (STANDARD CHARACTER)**. POLYTEX SPORTBELÄGE PODUKTIONSGMBH, MULTIPLE CLASS, (INT. CLS. 27 AND 37), (U.S. CLS. 19, 20, 37, 42, 50, 100, 103 AND 106). SN 79-071,461. PUB. 1-18-2011. FILED 6-22-2009.

3,940,038 ( *See Class 1 for this trademark*).

3,940,287. **BELLE CHASSE HOME (STANDARD CHARACTER)**. SIMON PAUL SCOTT, INC., DBA JARDINS EN FLEUR, (U.S. CLS. 19, 20, 37, 42 AND 50). SN 85-074,408. PUB. 1-18-2011. FILED 6-29-2010.

3,940,301 ( *See Class 12 for this trademark*).

3,940,939 ( *See Class 20 for this trademark*).

**CLASS 28—TOYS AND SPORTING GOODS**

3,939,349 ( *See Class 3 for this trademark*).

3,939,385. **AMBUSH (STANDARD CHARACTER)**. ROYAL WULFF PRODUCTS, INC., (U.S. CLS. 22, 23, 38 AND 50). SN 76-703,970. PUB. 1-18-2011. FILED 8-2-2010.

3,939,405 ( *See Class 9 for this trademark*).

3,939,406 ( *See Class 9 for this trademark*).

3,939,454. **IREST (STYLIZED)**. ZHEJIANG AILISITE HEALTH TECHNOLOGY CO., LTD., (U.S. CLS. 22, 23, 38 AND 50). SN 77-678,595. PUB. 1-18-2011. FILED 2-25-2009.

3,939,460. **MISCELLANEOUS DESIGN**. ROGERS ATHLETIC COMPANY, INC., (U.S. CLS. 22, 23, 38 AND 50). SN 77-692,809. PUB. 1-18-2011. FILED 3-17-2009.

3,939,491 ( *See Class 25 for this trademark*).

3,939,547. **EZ-TOSS (STANDARD CHARACTER)**. BEN-BASAT, JACKY, (U.S. CLS. 22, 23, 38 AND 50). SN 77-832,008. PUB. 1-18-2011. FILED 9-22-2009.

3,939,554. **IBB! (STANDARD CHARACTER)**. DURR MARKETING MANAGEMENT INC., (U.S. CLS. 22, 23, 38 AND 50). SN 77-840,763. PUB. 1-18-2011. FILED 10-3-2009.

3,939,623. **WOODLAND CLASSICS (STANDARD CHARACTER)**. DAVID L. OSMENT, (U.S. CLS. 22, 23, 38 AND 50). SN 77-911,072. PUB. 1-18-2011. FILED 1-13-2010.

3,939,700. **SNAG (STANDARD CHARACTER)**. SNAG, INC., (U.S. CLS. 22, 23, 38 AND 50). SN 77-932,342. PUB. 1-18-2011. FILED 2-10-2010.

3,939,731. **METAL XS (STYLIZED)**. MEGA BRANDS INTERNATIONAL, LUXEMBOURG, ZUG BRANCH, (U.S. CLS. 22, 23, 38 AND 50). SN 77-936,767. PUB. 1-18-2011. FILED 2-16-2010.

3,939,785. **ROSE SPLENDOR (STANDARD CHARACTER)**. MATTEL, INC., (U.S. CLS. 22, 23, 38 AND 50). SN 77-949,873. PUB. 1-18-2011. FILED 3-3-2010.

3,939,787. **XTR (STANDARD CHARACTER)**. IMPLUS FOOTCARE, LLC, (U.S. CLS. 22, 23, 38 AND 50). SN 77-950,338. PUB. 7-27-2010. FILED 3-4-2010.

3,939,883. **CERTIFIED SAFE AND DESIGN**. ICQ HOLDING S.R.L., MULTIPLE CLASS, (INT. CLS. 28 AND 42), (U.S. CLS. 22, 23, 38, 50, 100 AND 101). SN 79-060,823. PUB. 1-18-2011. FILED 9-1-2008.

3,939,895 ( *See Class 9 for this trademark*).

3,939,922 ( *See Class 14 for this trademark*).

3,939,931 ( *See Class 14 for this trademark*).

3,939,936 ( *See Class 3 for this trademark*).

3,939,979 ( *See Class 9 for this trademark*).

3,940,021 ( *See Class 9 for this trademark*).

3,940,029 ( *See Class 3 for this trademark*).

3,940,033 ( *See Class 5 for this trademark*).

3,940,047. **FIT FLIGHT AND DESIGN**. COSMO PRECISION MACHINE INC., (U.S. CLS. 22, 23, 38 AND 50). SN 79-085,301. PUB. 1-18-2011. FILED 6-18-2010.

3,940,056 ( *See Class 9 for this trademark*).

3,940,060. **SYPOBA (STANDARD CHARACTER)**. ROBIN STÄDLER, MULTIPLE CLASS, (INT. CLS. 28 AND 41), (U.S. CLS. 22, 23, 38, 50, 100, 101 AND 107). SN 79-086,658. PUB. 1-18-2011. FILED 7-8-2010.

3,940,065. **EZONE (STANDARD CHARACTER)**. YONEX KABUSHIKI KAISHA, (U.S. CLS. 22, 23, 38 AND 50). SN 79-087,288. PUB. 1-18-2011. FILED 8-16-2010.

3,940,153 ( *See Class 12 for this trademark*).

3,940,206. **OSCAR BONES (STANDARD CHARACTER)**. HEATHER J. BAILEY, (U.S. CLS. 22, 23, 38 AND 50). SN 85-051,476. PUB. 1-18-2011. FILED 6-1-2010.

3,940,388. **FLEET FF FARM AND DESIGN**. FLEET WHOLESALE SUPPLY CO., INC., (U.S. CLS. 22, 23, 38 AND 50). SN 85-093,468. PUB. 1-18-2011. FILED 7-27-2010.

3,940,423. **WRIST SNAPPER (STANDARD CHARACTER)**. ERNIE PARKER PRODUCTS, INC., (U.S. CLS. 22, 23, 38 AND 50). SN 85-095,961. PUB. 1-18-2011. FILED 7-29-2010.

3,940,445. **LILYBETH -GOLF- AND DESIGN**. LILYBETH GOLF LLC, (U.S. CLS. 22, 23, 38 AND 50). SN 85-096,832. PUB. 1-18-2011. FILED 7-30-2010.

3,940,519. **E-GLIDE (STANDARD CHARACTER)**. SPIRIT MANUFACTURING, INC., (U.S. CLS. 22, 23, 38 AND 50). SN 85-098,066. PUB. 1-18-2011. FILED 8-2-2010.

3,940,555 ( *See Class 12 for this trademark*).

3,940,601. **AIR-CORE WOODIES (STANDARD CHARACTER)**. INDIAN VALLEY LACROSSE CO., (U.S. CLS. 22, 23, 38 AND 50). SN 85-099,524. PUB. 1-18-2011. FILED 8-3-2010.

3,940,645. **CORMAX (STANDARD CHARACTER)**. LIFE-STYLE FITNESS, INC., (U.S. CLS. 22, 23, 38 AND 50). SN 85-100,130. PUB. 1-18-2011. FILED 8-4-2010.

3,940,724. **PEZO PALS (STANDARD CHARACTER)**. DR. PEZO, LLC, (U.S. CLS. 22, 23, 38 AND 50). SN 85-101,123. PUB. 1-18-2011. FILED 8-5-2010.

3,940,731. **REACH (STANDARD CHARACTER)**. ROSS OUTDOOR SPORTS SPECIALTIES, LLC, (U.S. CLS. 22, 23, 38 AND 50). SN 85-101,284. PUB. 1-18-2011. FILED 8-5-2010.

3,940,734. **FLYRISE (STANDARD CHARACTER)**. ROSS OUTDOOR SPORTS SPECIALTIES, LLC, (U.S. CLS. 22, 23, 38 AND 50). SN 85-101,300. PUB. 1-18-2011. FILED 8-5-2010.

3,940,789. **TINYTOTS (STANDARD CHARACTER)**. FUN PRODUCTS LLC, (U.S. CLS. 22, 23, 38 AND 50). SN 85-102,158. PUB. 1-18-2011. FILED 8-6-2010.

3,940,858. **SURFING IS MY RELIGION (STANDARD CHARACTER)**. SIMR, INC., (U.S. CLS. 22, 23, 38 AND 50). SN 85-103,537. PUB. 1-18-2011. FILED 8-9-2010.

3,940,898. **SNAP CIRCUITS (STANDARD CHARACTER)**. ELENCO ELECTRONICS, INC., (U.S. CLS. 22, 23, 38 AND 50). SN 85-113,281. PUB. 1-18-2011. FILED 8-23-2010.

3,940,901. **UNBREAKBALL (STANDARD CHARACTER)**. ARDWIN PRODUCTS LLC, (U.S. CLS. 22, 23, 38 AND 50). SN 85-115,317. PUB. 1-18-2011. FILED 8-25-2010.

3,940,905. **WINGBOARD - TAKE FLIGHT AND DESIGN**. WINGBOARD, INC., (U.S. CLS. 22, 23, 38 AND 50). SN 85-115,918. PUB. 1-18-2011. FILED 8-25-2010.

3,940,948. **USAIR (STYLIZED)**. US AIRWAYS, INC., (U.S. CLS. 22, 23, 38 AND 50). SN 85-134,926. PUB. 1-18-2011. FILED 9-21-2010.

**CLASS 29—MEATS AND PROCESSED FOODS**

3,939,544. **LUV'YA (STANDARD CHARACTER)**. HEARTLAND GROUP LIMITED, (U.S. CL. 46). SN 77-827,031. PUB. 1-18-2011. FILED 9-15-2009.

3,939,642. **SEA CHIPS (STANDARD CHARACTER)**. MAINE COAST SEA VEGETABLES, INC., (U.S. CL. 46). SN 77-919,323. PUB. 1-18-2011. FILED 1-25-2010.

3,939,680. **SUSPENDED FRESH (STANDARD CHARACTER)**. LOBAUGH, BRANDON, (U.S. CL. 46). SN 77-928,856. PUB. 1-18-2011. FILED 2-5-2010.

3,939,715. **MISCELLANEOUS DESIGN**. STARBUCKS CORPORATION, DBA STARBUCKS COFFEE COMPANY, MULTIPLE CLASS, (INT. CLS. 29, 30 AND 32), (U.S. CLS. 45, 46 AND 48). SN 77-935,439. PUB. 1-18-2011. FILED 2-14-2010.

3,939,728. **PEDERSON'S WENZEL (STANDARD CHARACTER)**. PEDERSON'S NATURAL FARMS, INC., (U.S. CL. 46). SN 77-936,593. PUB. 1-18-2011. FILED 2-16-2010.

3,939,757. **NAMAKIN (STANDARD CHARACTER)**. AMERICAN GOURMET IMPORTS, INC., FORMERLY AMERICAN ROYAL INTERNATIONAL, INC., (U.S. CL. 46). SN 77-940,977. PUB. 1-18-2011. FILED 2-21-2010.

3,939,766 ( *See Class 5 for this trademark*).

3,939,819. **GINGER CREEK AND DESIGN**. AMERICAN PARTNERS LLC, MULTIPLE CLASS, (INT. CLS. 29 AND 30), (U.S. CL. 46). SN 77-959,454. PUB. 1-18-2011. FILED 3-15-2010.

3,939,836. **DEL ABUELO TRADICION EN ALIMENTOS AND DESIGN**. IGNACIO DE LA PARRA Y DE LA PARRA, MARIO, (U.S. CL. 46). SN 77-964,297. PUB. 1-18-2011. FILED 3-21-2010.

3,939,840. **VEGA (STANDARD CHARACTER)**. SEQUEL NATURALS, INC., (U.S. CL. 46). SN 77-965,026. PUB. 1-18-2011. FILED 3-22-2010.

3,939,841. **VEGA AND DESIGN**. SEQUEL NATURALS, INC., (U.S. CL. 46). SN 77-965,049. PUB. 1-18-2011. FILED 3-22-2010.

3,939,845. **PLAZA DEL SOL (STANDARD CHARACTER)**. MOREALIM, MULTIPLE CLASS, (INT. CLS. 29, 30 AND 31), (U.S. CLS. 1 AND 46). SN 77-965,169. PUB. 1-18-2011. FILED 3-22-2010.

3,939,870. **NEW ZEALAND NATURAL (STANDARD CHARACTER)**. NZN INTERNATIONAL LICENSING PTY LIMITED, MULTIPLE CLASS, (INT. CLS. 29, 30 AND 35), (U.S. CLS. 46, 100, 101 AND 102). SN 78-649,273. PUB. 1-18-2011. FILED 6-13-2005.

3,939,928 ( *See Class 16 for this trademark*).

3,939,935. **OLIMP (STYLIZED)**. OLIMP LABORATORIES SP. Z O.O., MULTIPLE CLASS, (INT. CLS. 29 AND 30), (U.S. CL. 46). SN 79-077,751. PUB. 1-18-2011. FILED 11-10-2009.

3,939,947 ( *See Class 5 for this trademark*).

3,939,952. **INTERCOOP (STANDARD CHARACTER)**. GRUPO INTERCOOP INTERCOOPERACION,; AGROALIMENTARIA, S.L., (U.S. CL. 46). SN 79-080,031. PUB. 1-18-2011. FILED 2-17-2010.

3,939,957. **FROM; AND DESIGN**. FROM SOCIETÀ AGRICOLA COOPERATIVA, MULTIPLE CLASS, (INT. CLS. 29, 30, 31, 32 AND 33), (U.S. CLS. 1, 45, 46, 47, 48 AND 49). SN 79-080,313. PUB. 1-18-2011. FILED 10-16-2009.

3,939,966. **CAVIAR KRISTAL SÉLECTION AND DESIGN**. KAVIARI SAS, (U.S. CL. 46). SN 79-080,582. PUB. 1-18-2011. FILED 2-4-2010.

3,939,989 ( *See Class 5 for this trademark*).

3,939,993. **VILLAROBLES AND DESIGN**. ENOTRIA ITALIA DI FRANCESCO CHIERICATI, (U.S. CL. 46). SN 79-081,396. PUB. 1-18-2011. FILED 2-16-2010.

3,940,008. **LATTERIA PLAC DAL 1933 CREMONA AND DESIGN**. PRODUTTORI LATTE ASSOCIATI CREMONA -; SOC. COOP. AGRICOLA (P.L.A.C.), (U.S. CL. 46). SN 79-082,410. PUB. 1-18-2011. FILED 3-5-2010.

3,940,010. **FERRERO NICE (STYLIZED)**. SOREMARTEC SA, MULTIPLE CLASS, (INT. CLS. 29 AND 30), (U.S. CL. 46). SN 79-082,528. PUB. 1-18-2011. FILED 2-5-2010.

3,940,046. **CACAO BARRY (STYLIZED)**. BARRY CALLEBAUT FRANCE, SOCIÉTÉ PAR ACTIONS SIMPLIFIÉE, MULTIPLE CLASS, (INT. CLS. 29, 30 AND 31), (U.S. CLS. 1 AND 46). SN 79-085,142. PUB. 1-18-2011. FILED 7-2-2010.

3,940,051. **NORCINETTO (STYLIZED)**. CESARE FIORUCCI

- S.P.A., (U.S. CL. 46). SN 79-085,647. PUB. 1-18-2011. FILED 1-20-2010.
- 3,940,100. **RISE MOON ORGANICS AND DESIGN**. UNITED NATURAL FOODS, INC., MULTIPLE CLASS, (INT. CLS. 29 AND 30), (U.S. CL. 46). SN 85-012,780. PUB. 1-18-2011. FILED 4-13-2010.
- 3,940,112. **BOCCALONE AND DESIGN**. BOCCALONE, LLC, DBA BOCCALONE, (U.S. CL. 46). SN 85-016,336. PUB. 1-18-2011. FILED 4-16-2010.
- 3,940,134. **COPY CAT (STANDARD CHARACTER)**. GLOBAL FOOD TRADING CORP., (U.S. CL. 46). SN 85-028,594. PUB. 1-18-2011. FILED 5-3-2010.
- 3,940,146 ( *See Class 18 for this trademark*).
- 3,940,223. **WATER LILIES FINE ASIAN CUISINE AND DESIGN**. WATER LILIES FOOD INC., MULTIPLE CLASS, (INT. CLS. 29 AND 30), (U.S. CL. 46). SN 85-056,700. PUB. 1-18-2011. FILED 6-7-2010.
- 3,940,529. **WARNING: MAY MAKE YOU FEEL SEXY. (STANDARD CHARACTER)**. FILTHY BRANDS, LLC, MULTIPLE CLASS, (INT. CLS. 29 AND 35), (U.S. CLS. 46, 100, 101 AND 102). SN 85-098,278. PUB. 1-18-2011. FILED 8-2-2010.
- 3,940,720. **OH, BABY BACK RIBS (STANDARD CHARACTER)**. BENNIGAN'S IP, LLC, (U.S. CL. 46). SN 85-101,017. PUB. 1-18-2011. FILED 8-5-2010.
- 3,940,770. **MISCELLANEOUS DESIGN**. FILTHY BRANDS, LLC, (U.S. CL. 46). SN 85-101,845. PUB. 1-18-2011. FILED 8-6-2010.
- 3,940,919. **A CHICKEN SANDWICH WORTH LOOKING INTO. (STANDARD CHARACTER)**. FRANK BRUNCKHORST CO., L.L.C., (U.S. CL. 46). SN 85-119,725. PUB. 1-18-2011. FILED 8-31-2010.
- 
- CLASS 30—STAPLE FOODS**
- 3,939,366. **FROZEN GURU (STANDARD CHARACTER)**. FROZEN GURU LLC, (U.S. CL. 46). SN 76-701,757. PUB. 1-18-2011. FILED 2-22-2010.
- 3,939,410. **KAUAI PIE (STANDARD CHARACTER)**. LAPPERT'S, INC., (U.S. CL. 46). SN 77-342,403. PUB. 6-2-2009. FILED 12-3-2007.
- 3,939,437. **HAN PPU RI (STANDARD CHARACTER)**. CJ CHEILJEDANG CORPORATION, (U.S. CL. 46). SN 77-599,326. PUB. 1-18-2011. FILED 10-23-2008.
- 3,939,464. **PINK SWIRL FROZEN YOGURT AND DESIGN**. PINK SWIRL FROZEN YOGURT LLC, (U.S. CL. 46). SN 77-704,077. PUB. 9-22-2009. FILED 4-1-2009.
- 3,939,481 ( *See Class 5 for this trademark*).
- 3,939,590. **STEPHEN'S AND DESIGN**. INDULGENT FOODS, LLC, (U.S. CL. 46). SN 77-880,206. PUB. 1-18-2011. FILED 11-24-2009.
- 3,939,615. **DOUCE FRANCE AND DESIGN**. FERREIRA, MAURO R, DBA DOUCE FRANCE, (U.S. CL. 46). SN 77-902,182. PUB. 1-18-2011. FILED 12-29-2009.
- 3,939,641. **MAINE COAST SEA VEGETABLES (STANDARD CHARACTER)**. MAINE COAST SEA VEGETABLES, INC., (U.S. CL. 46). SN 77-919,134. PUB. 1-18-2011. FILED 1-25-2010.
- 3,939,679. **AMERICA'S FAVORITE HEINZ ORIGINAL COCKTAIL SAUCE AND DESIGN**. PROMARK BRANDS INC., (U.S. CL. 46). SN 77-928,833. PUB. 1-18-2011. FILED 2-5-2010.
- 3,939,715 ( *See Class 29 for this trademark*).
- 3,939,740. **WAYKURAT (STANDARD CHARACTER)**. FBC WORLDWIDE, LLC, (U.S. CL. 46). SN 77-938,389. PUB. 1-18-2011. FILED 2-18-2010.
- 3,939,744. **UNCLE FRANK'S SINCE 1986 AND DESIGN**. NOWICKI, FRANK, (U.S. CL. 46). SN 77-939,367. PUB. 1-18-2011. FILED 2-18-2010.
- 3,939,819 ( *See Class 29 for this trademark*).
- 3,939,845 ( *See Class 29 for this trademark*).
- 3,939,870 ( *See Class 29 for this trademark*).
- 3,939,871. **YET CA MEIN (STANDARD CHARACTER)**. WING HING LUNG LTD., (U.S. CL. 46). SN 78-711,376. PUB. 1-18-2011. FILED 9-12-2005.
- 3,939,913 ( *See Class 3 for this trademark*).
- 3,939,928 ( *See Class 16 for this trademark*).
- 3,939,935 ( *See Class 29 for this trademark*).
- 3,939,947 ( *See Class 5 for this trademark*).
- 3,939,957 ( *See Class 29 for this trademark*).
- 3,939,959. **ETI TUTKU AND DESIGN**. ETI GIDA; SANAYI VE TICARET ANONIM SIRKETI, (U.S. CL. 46). SN 79-080,353. PUB. 1-18-2011. FILED 11-12-2009.
- 3,939,974. **PARTY DELIC-POL AND DESIGN**. "DELIC-POL" SPOLKA AKCYJNA, (U.S. CL. 46). SN 79-080,788. PUB. 1-18-2011. FILED 2-18-2010.
- 3,940,010 ( *See Class 29 for this trademark*).
- 3,940,041. **BELLA BOCA (STYLIZED)**. BON TON LICENSING BV, (U.S. CL. 46). SN 79-084,993. PUB. 1-18-2011. FILED 5-26-2010.
- 3,940,046 ( *See Class 29 for this trademark*).
- 3,940,088 ( *See Class 5 for this trademark*).
- 3,940,100 ( *See Class 29 for this trademark*).
- 3,940,129. **COLCHONES (STANDARD CHARACTER)**. GRUPO BIMBO, S.A.B. DE C.V., (U.S. CL. 46). SN 85-025,487. PUB. 1-18-2011. FILED 4-28-2010.
- 3,940,146 ( *See Class 18 for this trademark*).
- 3,940,203. **MOTLEE'S (STANDARD CHARACTER)**. CREATIVE TRADE WORLD, INC., MULTIPLE CLASS, (INT. CLS. 30 AND 32), (U.S. CLS. 45, 46 AND 48). SN 85-049,786. PUB. 8-17-2010. FILED 5-27-2010.
- 3,940,208. **MRS. PRINDABLE'S AND DESIGN**. AFFY TAPLE, L.L.C., (U.S. CL. 46). SN 85-051,792. PUB. 1-18-2011. FILED 6-1-2010.
- 3,940,216 ( *See Class 5 for this trademark*).
- 3,940,223 ( *See Class 29 for this trademark*).
- 3,940,267. **TAMÁLAGO CAFE TASTE THE TAMALES REVOLUTION! AND DESIGN**. RAQUEL CONTRERAS, DBA TAMÁLAGO CAFÉ, (U.S. CL. 46). SN 85-069,065. PUB. 1-18-2011. FILED 6-22-2010.
- 3,940,281. **POR SU RICO SABOR CASERO (STANDARD CHARACTER)**. GRUPO BIMBO, S.A.B. DE C.V., (U.S. CL. 46). SN 85-072,683. PUB. 1-18-2011. FILED 6-28-2010.
- 3,940,283 ( *See Class 9 for this trademark*).
- 3,940,325. **GEEBES CHAI GOLD (STANDARD CHARACTER)**. ROYAL BLUE STAR INTERNATIONAL, INC., (U.S. CL. 46). SN 85-083,231. PUB. 1-18-2011. FILED 7-13-2010.
- 3,940,331. **LIFE IS COFFEE! (STANDARD CHARACTER)**. THE OMAR COFFEE COMPANY, (U.S. CL. 46). SN 85-084,556. PUB. 1-18-2011. FILED 7-14-2010.
- 3,940,344. **FRED MEYER ALIEN (STANDARD CHARACTER)**. FRED MEYER STORES, INC, (U.S. CL. 46). SN 85-087,038. PUB. 1-18-2011. FILED 7-16-2010.
- 3,940,352. **JUST TASTE IT! (STANDARD CHARACTER)**. G3 DISTRIBUTORS, LLC, (U.S. CL. 46). SN 85-088,374. PUB. 1-18-2011. FILED 7-20-2010.
- 3,940,353. **MARCIA'S MUNCHIES (STANDARD CHARACTER)**. MARCIA'S MUNCHIES LLC, (U.S. CL. 46). SN 85-088,405. PUB. 1-18-2011. FILED 7-20-2010.
- 3,940,424. **SOMETHING TO CROW ABOUT AND DESIGN**. DAYLIGHT DONUT FLOUR CO., L.L.C., (U.S. CL. 46). SN 85-095,963. PUB. 1-18-2011. FILED 7-29-2010.
- 3,940,429. **MISCELLANEOUS DESIGN**. TERRY HARRIS, (U.S. CL. 46). SN 85-096,238. PUB. 1-18-2011. FILED 7-29-2010.
- 3,940,475. **STAY COOL (STYLIZED)**. PREFERRED TEA, LLC, (U.S. CL. 46). SN 85-097,442. PUB. 1-18-2011. FILED 7-30-2010.
- 3,940,476. **PT PREFERRED TEA AND DESIGN**. KARAN R. MOSELEY, DBA PREFERRED TEA, (U.S. CL. 46). SN 85-097,450. PUB. 1-18-2011. FILED 7-31-2010.
- 3,940,502. **PUB BITES (STANDARD CHARACTER)**. BENNIGAN'S IP, LLC, (U.S. CL. 46). SN 85-097,763. PUB. 1-18-2011. FILED 8-2-2010.
- 3,940,504. **EMERALD ISLE CLUB (STANDARD CHARACTER)**. BENNIGAN'S IP, LLC, (U.S. CL. 46). SN 85-097,787. PUB. 1-18-2011. FILED 8-2-2010.
- 3,940,527. **DARING DONUTS AND DESIGN**. DARING DONUTS LLC, (U.S. CL. 46). SN 85-098,173. PUB. 1-18-2011. FILED 8-2-2010.
- 3,940,595. **CORE BOTANICA (STANDARD CHARACTER)**. CORE BOTANICA, L.L.C., (U.S. CL. 46). SN 85-099,399. PUB. 1-18-2011. FILED 8-3-2010.
- 3,940,602. **SNOOGLE (STANDARD CHARACTER)**. TIMOTHY J. KIEDROWSKI, DBA KIEDROWSKI'S SIMPLY DELICIOUS BAKERY, AND TERESA R. KIEDROWSKI, DBA

KIEDROWSKI'S SIMPLY DELICIOUS BAKERY, (U.S. CL. 46). SN 85-099,531. PUB. 1-18-2011. FILED 8-3-2010.

3,940,658. **BBB AND DESIGN**. M2H INVESTMENTS, INC., DBA DILLANOS COFFEE ROASTERS, (U.S. CL. 46). SN 85-100,254. PUB. 1-18-2011. FILED 8-4-2010.

3,940,662. **BBB BATCH-BY-BATCH AND DESIGN**. M2H INVESTMENTS, INC., DBA DILLANOS COFFEE ROASTERS, (U.S. CL. 46). SN 85-100,332. PUB. 1-18-2011. FILED 8-4-2010.

3,940,670. **KONA CLOUD COFFEE ESTATES, INC. (STANDARD CHARACTER)**. KONA CLOUD COFFEE ESTATES INC, (U.S. CL. 46). SN 85-100,448. PUB. 1-18-2011. FILED 8-4-2010.

3,940,677. **ARUBICA (STANDARD CHARACTER)**. TZVETANOV, MILEN, DBA ESPRESSO 2.0 LLC, (U.S. CL. 46). SN 85-100,515. PUB. 1-18-2011. FILED 8-4-2010.

3,940,698. **FAY DA BAKERY (STANDARD CHARACTER)**. CHOW, KELLEN, MULTIPLE CLASS, (INT. CLS. 30, 35 AND 43), (U.S. CLS. 46, 100, 101 AND 102). SN 85-100,793. PUB. 1-18-2011. FILED 8-5-2010.

3,940,750. **CHORIPERRO (STANDARD CHARACTER)**. LOZANO, CARLOS, (U.S. CL. 46). SN 85-101,506. PUB. 1-18-2011. FILED 8-5-2010.

3,940,751. **LOMIPERRO (STANDARD CHARACTER)**. LOZANO, CARLOS, (U.S. CL. 46). SN 85-101,513. PUB. 1-18-2011. FILED 8-5-2010.

3,940,752. **POLLIPERRO (STANDARD CHARACTER)**. LOZANO, CARLOS, (U.S. CL. 46). SN 85-101,524. PUB. 1-18-2011. FILED 8-5-2010.

3,940,769. **WEEFULLS (STANDARD CHARACTER)**. LIFE STUDIO INC., (U.S. CL. 46). SN 85-101,835. PUB. 1-18-2011. FILED 8-6-2010.

3,940,774. **BOMVASO (STANDARD CHARACTER)**. WM. WRIGLEY JR. COMPANY, (U.S. CL. 46). SN 85-101,937. PUB. 1-18-2011. FILED 8-6-2010.

3,940,833. **SNACK RESPONSIBLY (STANDARD CHARACTER)**. FRONT RANGE SNACKS, INC., (U.S. CL. 46). SN 85-102,707. PUB. 1-18-2011. FILED 8-8-2010.

3,940,836. **EDOUGBLE THE READY-TO-EAT COOKIE DOUGH TREAT! AND DESIGN**. WERBER, RANA ERIN, AND LUSTYAN V. JOHN FRANCIS, (U.S. CL. 46). SN 85-102,968. PUB. 1-18-2011. FILED 8-9-2010.

3,940,882. **GOT KOSHER? ORIGINAL PRETZEL CHALLAH (STANDARD CHARACTER)**. KOSHER FOODS UNLIMITED, INC., DBA GOT KOSHER?, (U.S. CL. 46). SN 85-110,158. PUB. 1-18-2011. FILED 8-18-2010.

### CLASS 31—NATURAL AGRICULTURAL PRODUCTS

3,939,380. **BYBEE SWEETS (STANDARD CHARACTER)**. BYBEE, CLYDE, (U.S. CLS. 1 AND 46). SN 76-703,509. PUB. 1-18-2011. FILED 6-24-2010.

3,939,430. **SUNBURSTS (STANDARD CHARACTER)**. DESERT GLORY, LTD. (U.S. CLS. 1 AND 46). SN 77-543,924. PUB. 7-20-2010. FILED 8-11-2008.

3,939,501. **BABCOCK (STANDARD CHARACTER)**. INSTITUT DE SELECTION ANIMALE - ISA, (U.S. CLS. 1 AND 46). SN 77-783,449. PUB. 1-18-2011. FILED 7-17-2009.

3,939,559. **SUNCRISP (STANDARD CHARACTER)**. RUTGERS, THE STATE UNIVERSITY, (U.S. CLS. 1 AND 46). SN 77-847,476. PUB. 1-18-2011. FILED 10-13-2009.

3,939,845 ( *See Class 29 for this trademark*).

3,939,854. **TREAT ME NATURALLY (STANDARD CHARACTER)**. MARK HEYWARD, (U.S. CLS. 1 AND 46). SN 77-967,310. PUB. 1-18-2011. FILED 3-24-2010.

3,939,957 ( *See Class 29 for this trademark*).

3,939,982. **DAILY PREMIUM APPLE AND DESIGN**. GYEONGSANGBUK-DO, (U.S. CLS. 1 AND 46). SN 79-081,086. PUB. 1-18-2011. FILED 2-12-2010.

3,940,046 ( *See Class 29 for this trademark*).

3,940,120. **FISH 'N' WAVES (STANDARD CHARACTER)**. WELLPET LLC, (U.S. CLS. 1 AND 46). SN 85-018,548. PUB. 1-18-2011. FILED 4-20-2010.

3,940,665. **JOSHUA'S PET TREAT BAKERY (STANDARD CHARACTER)**. DAVIS, LOIS, (U.S. CLS. 1 AND 46). SN

85-100,370. PUB. 1-18-2011. FILED 8-4-2010.

3,940,790. **THE LITTLE BIG CORN (STANDARD CHARACTER)**. MOHR-FRY RANCHES, (U.S. CLS. 1 AND 46). SN 85-102,164. PUB. 1-18-2011. FILED 8-6-2010.

3,940,845. **PORK CHOMPS AND DESIGN**. SCOTT PET PRODUCTS, INC., (U.S. CLS. 1 AND 46). SN 85-103,425. PUB. 1-18-2011. FILED 8-9-2010.

3,940,866. **TREADWELL (STANDARD CHARACTER)**. EXTERIOR DESIGN, INC., TA THE PERENNIAL FARM, (U.S. CLS. 1 AND 46). SN 85-106,294. PUB. 1-18-2011. FILED 8-12-2010.

3,940,867. **TREADWELL AND DESIGN**. EXTERIOR DESIGN, INC., TA THE PERENNIAL FARM, (U.S. CLS. 1 AND 46). SN 85-106,377. PUB. 1-18-2011. FILED 8-12-2010.

3,940,910. **LAMB PUFFS (STANDARD CHARACTER)**. IMS TRADING CORPORATION, (U.S. CLS. 1 AND 46). SN 85-116,696. PUB. 1-18-2011. FILED 8-26-2010.

### CLASS 32—LIGHT BEVERAGES

3,939,347. **BISON**. BISON BREWING COMPANY, LLC, MULTIPLE CLASS, (INT. CLS. 32 AND 33), (U.S. CLS. 45, 46, 47, 48 AND 49). SN 76-296,791. PUB. 1-18-2011. FILED 8-7-2001.

3,939,355 ( *See Class 24 for this trademark*).

3,939,395 ( *See Class 5 for this trademark*).

3,939,426. **THE HEALTHY HYDRATION COMPANY (STANDARD CHARACTER)**. SOCIETE DES PRODUITS NESTLE S.A., MULTIPLE CLASS, (INT. CLS. 32, 39, 41, 43 AND 44), (U.S. CLS. 45, 46, 48, 100, 101, 105 AND 107). SN 77-497,413. PUB. 1-18-2011. FILED 6-12-2008.

3,939,455. **FEEL THE NEED AND DESIGN**. BRIAN OWENS, AND KARIN MUCCI, (U.S. CLS. 45, 46 AND 48). SN 77-683,085. PUB. 1-18-2011. FILED 3-4-2009.

3,939,703. **INCA BLU (STYLIZED)**. LUMAT INC., (U.S. CLS. 45, 46 AND 48). SN 77-932,987. PUB. 1-18-2011. FILED 2-10-2010.

3,939,715 ( *See Class 29 for this trademark*).

3,939,822. **DOSXTRES (STYLIZED)**. SUNRISE MEDIA GROUP, INC., (U.S. CLS. 45, 46 AND 48). SN 77-959,857. PUB. 1-18-2011. FILED 3-16-2010.

3,939,844 ( *See Class 5 for this trademark*).

3,939,863. **RED**. RED BULL GMBH, (U.S. CLS. 45, 46 AND 48). SN 78-191,805. PUB. 9-4-2007. FILED 12-5-2002.

3,939,947 ( *See Class 5 for this trademark*).

3,939,957 ( *See Class 29 for this trademark*).

3,939,968. **LE FRUIT NU (STANDARD CHARACTER)**. NEMECO, (U.S. CLS. 45, 46 AND 48). SN 79-080,590. PUB. 1-18-2011. FILED 1-22-2010.

3,940,014. **BLOOD ORANGE MIMOSA CANELLA AND DESIGN**. EMPSON & CO. S.P.A., AND CASA VINICOLA CANELLA S.P.A., MULTIPLE CLASS, (INT. CLS. 32, 33 AND 35), (U.S. CLS. 45, 46, 47, 48, 49, 100, 101 AND 102). SN 79-082,813. PUB. 1-18-2011. FILED 3-30-2010.

3,940,024 ( *See Class 18 for this trademark*).

3,940,049. **M AND DESIGN**. MAHOU, S.A., MULTIPLE CLASS, (INT. CLS. 32 AND 39), (U.S. CLS. 45, 46, 48, 100 AND 105). SN 79-085,388. PUB. 1-18-2011. FILED 5-17-2010.

3,940,089 ( *See Class 5 for this trademark*).

3,940,203 ( *See Class 30 for this trademark*).

3,940,323. **CAMO BLACK (STANDARD CHARACTER)**. WILLIAMS III, ROBERT K. (U.S. CLS. 45, 46 AND 48). SN 85-083,073. PUB. 1-18-2011. FILED 7-13-2010.

3,940,334. **VIOVI AND DESIGN**. O'BIOLLA CORPORATION, (U.S. CLS. 45, 46 AND 48). SN 85-085,573. PUB. 1-18-2011. FILED 7-15-2010.

3,940,362. **MISCELLANEOUS DESIGN**. PURE INVENTIONS, LLC, (U.S. CLS. 45, 46 AND 48). SN 85-089,677. PUB. 1-18-2011. FILED 7-21-2010.

3,940,389. **CUBITA AND DESIGN**. DM ENTERPRISES & DISTRIBUTORS, INC., (U.S. CLS. 45, 46 AND 48). SN 85-093,497. PUB. 1-18-2011. FILED 7-27-2010.

3,940,398. **TOMR'S (STANDARD CHARACTER)**. TOM'S HANDCRAFTED L.L.C., (U.S. CLS. 45, 46 AND 48). SN 85-094,188. PUB. 1-18-2011. FILED 7-27-2010.

3,940,474. **VIBE COCKTAIL MIXES (STANDARD CHARACTER)**. AGAPE CONDIMENTS & BEVERAGE, INC., DBA



THE GARLIC LADY, (U.S. CLS. 45, 46 AND 48). SN 85-097,437. PUB. 1-18-2011. FILED 7-30-2010.  
 3,940,639. **AMBERGEDDON AND DESIGN**. ALE ASYLUM, LLC, (U.S. CLS. 45, 46 AND 48). SN 85-100,052. PUB. 1-18-2011. FILED 8-4-2010.  
 3,940,643. **BEDLAM! AND DESIGN**. ALE ASYLUM, LLC, (U.S. CLS. 45, 46 AND 48). SN 85-100,113. PUB. 1-18-2011. FILED 8-4-2010.  
 3,940,654. **TRIPEL NOVA AND DESIGN**. ALE ASYLUM, LLC, (U.S. CLS. 45, 46 AND 48). SN 85-100,191. PUB. 1-18-2011. FILED 8-4-2010.  
 3,940,900. **ALTUNSA EURO DRINK AND DESIGN**. ALTUNKAYA INSAAT NAKLIYAT GIDA TICARET ANONIM SIRKETI, (U.S. CLS. 45, 46 AND 48). SN 85-115,308. PUB. 1-18-2011. FILED 8-25-2010.  
 3,940,906. **GLACIER BREWHOUSE (STANDARD CHARACTER)**. A F AND G, LLC, MULTIPLE CLASS, (INT. CLS. 32 AND 43), (U.S. CLS. 45, 46, 48, 100 AND 101). SN 85-115,967. PUB. 1-18-2011. FILED 8-25-2010.  
 3,940,928 ( *See Class 5 for this trademark*).  
 3,940,929 ( *See Class 5 for this trademark*).  
 3,940,946 ( *See Class 5 for this trademark*).  
 3,940,968. **ALPHA KING (STANDARD CHARACTER)**. THREE FLOYDS BREWING LLC, (U.S. CLS. 45, 46 AND 48). SN 85-155,454. PUB. 1-18-2011. FILED 10-18-2010.

### CLASS 33—WINES AND SPIRITS

3,939,347 ( *See Class 32 for this trademark*).  
 3,939,398. **ARNE (STANDARD CHARACTER)**. L'ORMARINS (PTY) LIMITED, (U.S. CLS. 47 AND 49). SN 77-218,368. PUB. 1-18-2011. FILED 6-28-2007.  
 3,939,427. **T2 AND DESIGN**. CAROLINA ONE, INC., (U.S. CLS. 47 AND 49). SN 77-527,409. PUB. 1-18-2011. FILED 7-21-2008.  
 3,939,773. **BUISSON RENARD AND DESIGN**. EARL DIDIER DAGUENEAU, (U.S. CLS. 47 AND 49). SN 77-946,055. PUB. 1-18-2011. FILED 2-26-2010.  
 3,939,774. **BUISSON RENARD (STANDARD CHARACTER)**. EARL DIDIER DAGUENEAU, (U.S. CLS. 47 AND 49). SN 77-946,090. PUB. 1-18-2011. FILED 2-26-2010.  
 3,939,817. **MISCELLANEOUS DESIGN**. WILLIAM GRANT & SONS MARKETING, LTD, (U.S. CLS. 47 AND 49). SN 77-959,303. PUB. 1-18-2011. FILED 3-15-2010.  
 3,939,824. **GRAPEHEAD (STANDARD CHARACTER)**. FERRARA PAN CANDY CO., INC., (U.S. CLS. 47 AND 49). SN 77-960,933. PUB. 1-18-2011. FILED 3-17-2010.  
 3,939,917. **ORSETTO ORO AND DESIGN**. CASAL THAU-LERO SRL, (U.S. CLS. 47 AND 49). SN 79-074,823. PUB. 1-18-2011. FILED 6-19-2009.  
 3,939,918. **CHIANTI COLLI FIORENTINI AND DESIGN**. CONSORZIO CHIANTI COLLI FIORENTINI, (U.S. CLS. 47 AND 49). SN 79-074,835. PUB. 1-18-2011. FILED 9-11-2009.  
 3,939,957 ( *See Class 29 for this trademark*).  
 3,939,965. **FAC ET SPERA (STANDARD CHARACTER)**. M. CHAPOUTIER, (U.S. CLS. 47 AND 49). SN 79-080,453. PUB. 1-18-2011. FILED 2-16-2010.  
 3,939,996. **VINGEL (STANDARD CHARACTER)**. ITALGELATINE S.P.A., (U.S. CLS. 47 AND 49). SN 79-081,613. PUB. 1-18-2011. FILED 12-18-2009.  
 3,940,006. **GRANDE RESERVE DES BASTIDES (STANDARD CHARACTER)**. CAVE DE LABASTIDE DE LEVIS, (U.S. CLS. 47 AND 49). SN 79-082,072. PUB. 1-18-2011. FILED 3-24-2010.  
 3,940,014 ( *See Class 32 for this trademark*).  
 3,940,018. **INSPIRATION PAMPANO AND DESIGN**. AGRICOLA CASTELLANA, SDAD. COOP. LTDA., (U.S. CLS. 47 AND 49). SN 79-083,033. PUB. 1-18-2011. FILED 3-11-2010.  
 3,940,045. **MATARROMERA (STANDARD CHARACTER)**. LUIS CARLOS MORO GONZALEZ, (U.S. CLS. 47 AND 49). SN 79-085,116. PUB. 1-18-2011. FILED 5-28-2010.  
 3,940,058. **SARGIS AND DESIGN**. ARARAT COGNAC FACTORY 'A.K.Z.' LTD, (U.S. CLS. 47 AND 49). SN 79-086,458. PUB. 1-18-2011. FILED 6-23-2010.  
 3,940,064. **ROQUETTE & CAZES AND DESIGN**. ROQUETTE & CAZES, LDA, (U.S. CLS. 47 AND 49). SN 79-087,202. PUB.

1-18-2011. FILED 7-27-2010.  
 3,940,127. **ESTA (STANDARD CHARACTER)**. SOCIEDADE DOS VINHOS BORGES, S.A., (U.S. CLS. 47 AND 49). SN 85-023,992. PUB. 1-18-2011. FILED 4-27-2010.  
 3,940,228 ( *See Class 6 for this trademark*).  
 3,940,230. **ROSA DI SERA (STANDARD CHARACTER)**. CANTINA SOCIALE BEATO BARTOLOMEO DA BREGANZE SOCIETA' COOPERATIVA AGRICOLA A RESPONSABILITA' LIMITATA, (U.S. CLS. 47 AND 49). SN 85-058,164. PUB. 12-21-2010. FILED 6-9-2010.  
 3,940,299. **GRAND TOURING VODKA (STANDARD CHARACTER)**. GRAND TOURING VODKA, LLC, (U.S. CLS. 47 AND 49). SN 85-078,696. PUB. 1-18-2011. FILED 7-6-2010.  
 3,940,300. **GT (STANDARD CHARACTER)**. GRAND TOURING VODKA, LLC, (U.S. CLS. 47 AND 49). SN 85-078,733. PUB. 1-18-2011. FILED 7-6-2010.  
 3,940,336 ( *See Class 16 for this trademark*).  
 3,940,383. **BIG PINK (STANDARD CHARACTER)**. BORDIGIONI FAMILY WINERY, LLC, (U.S. CLS. 47 AND 49). SN 85-093,166. PUB. 1-18-2011. FILED 7-26-2010.  
 3,940,417. **GREG NORMAN (STANDARD CHARACTER)**. GREAT WHITE SHARK ENTERPRISES, INC., (U.S. CLS. 47 AND 49). SN 85-095,493. PUB. 1-18-2011. FILED 7-29-2010.  
 3,940,418. **MISCELLANEOUS DESIGN**. GREAT WHITE SHARK ENTERPRISES, INC., (U.S. CLS. 47 AND 49). SN 85-095,500. PUB. 1-18-2011. FILED 7-29-2010.  
 3,940,459 ( *See Class 21 for this trademark*).  
 3,940,539. **ANTIGUO IMPERIO (STANDARD CHARACTER)**. CASA TEQUILERA DE ARANDAS, S.A. DE C.V., (U.S. CLS. 47 AND 49). SN 85-098,451. PUB. 1-18-2011. FILED 8-2-2010.  
 3,940,634. **MISCELLANEOUS DESIGN**. MARTHA CLARA VINEYARDS, LLC, (U.S. CLS. 47 AND 49). SN 85-099,973. PUB. 1-18-2011. FILED 8-4-2010.  
 3,940,779. **LA REVANCHA (STANDARD CHARACTER)**. GRUPO INTERNACIONAL DE EXPORTACION, S.A. DE C.V., (U.S. CLS. 47 AND 49). SN 85-101,999. PUB. 1-18-2011. FILED 8-6-2010.  
 3,940,780. **MARIAN'S VINEYARD (STANDARD CHARACTER)**. MOHR-FRY RANCHES, (U.S. CLS. 47 AND 49). SN 85-102,007. PUB. 1-18-2011. FILED 8-6-2010.  
 3,940,783. **MOHR-FRY RANCH (STANDARD CHARACTER)**. MOHR-FRY RANCHES, (U.S. CLS. 47 AND 49). SN 85-102,026. PUB. 1-18-2011. FILED 8-6-2010.  
 3,940,788. **EL RETIRO (STANDARD CHARACTER)**. GRUPO INTERNACIONAL DE EXPORTACION, S.A. DE C.V., (U.S. CLS. 47 AND 49). SN 85-102,135. PUB. 1-18-2011. FILED 8-6-2010.  
 3,940,800 ( *See Class 33 for this trademark*).  
 3,940,801 ( *See Class 33 for this trademark*).  
 3,940,802 ( *See Class 33 for this trademark*).  
 3,940,803 ( *See Class 33 for this trademark*).  
 3,940,804 ( *See Class 33 for this trademark*).  
 3,940,805 ( *See Class 33 for this trademark*).  
 3,940,806 ( *See Class 33 for this trademark*).  
 3,940,807 ( *See Class 33 for this trademark*).  
 3,940,808 ( *See Class 33 for this trademark*).  
 3,940,809 ( *See Class 33 for this trademark*).  
 3,940,810 ( *See Class 33 for this trademark*).  
 3,940,811 ( *See Class 33 for this trademark*).  
 3,940,812 ( *See Class 33 for this trademark*).  
 3,940,813 ( *See Class 33 for this trademark*).  
 3,940,814 ( *See Class 33 for this trademark*).  
 3,940,815 ( *See Class 33 for this trademark*).  
 3,940,816 ( *See Class 33 for this trademark*).  
 3,940,817 ( *See Class 33 for this trademark*).  
 3,940,818 ( *See Class 33 for this trademark*).  
 3,940,819 ( *See Class 33 for this trademark*).  
 3,940,820 ( *See Class 33 for this trademark*).  
 3,940,821 ( *See Class 33 for this trademark*).  
 3,940,822 ( *See Class 33 for this trademark*).  
 3,940,823 ( *See Class 33 for this trademark*).  
 3,940,824 ( *See Class 33 for this trademark*).  
 3,940,825 ( *See Class 33 for this trademark*).  
 3,940,826 ( *See Class 33 for this trademark*).  
 3,940,827 ( *See Class 33 for this trademark*).  
 3,940,828 ( *See Class 33 for this trademark*).  
 3,940,829 ( *See Class 33 for this trademark*).  
 3,940,830 ( *See Class 33 for this trademark*).  
 3,940,831 ( *See Class 33 for this trademark*).  
 3,940,832 ( *See Class 33 for this trademark*).  
 3,940,833 ( *See Class 33 for this trademark*).  
 3,940,834 ( *See Class 33 for this trademark*).  
 3,940,835 ( *See Class 33 for this trademark*).  
 3,940,836 ( *See Class 33 for this trademark*).  
 3,940,837 ( *See Class 33 for this trademark*).  
 3,940,838 ( *See Class 33 for this trademark*).  
 3,940,839 ( *See Class 33 for this trademark*).  
 3,940,840 ( *See Class 33 for this trademark*).  
 3,940,841 ( *See Class 33 for this trademark*).  
 3,940,842 ( *See Class 33 for this trademark*).  
 3,940,843 ( *See Class 33 for this trademark*).  
 3,940,844 ( *See Class 33 for this trademark*).  
 3,940,845 ( *See Class 33 for this trademark*).  
 3,940,846 ( *See Class 33 for this trademark*).  
 3,940,847 ( *See Class 33 for this trademark*).  
 3,940,848 ( *See Class 33 for this trademark*).  
 3,940,849 ( *See Class 33 for this trademark*).  
 3,940,850 ( *See Class 33 for this trademark*).  
 3,940,851 ( *See Class 33 for this trademark*).  
 3,940,852 ( *See Class 33 for this trademark*).  
 3,940,853 ( *See Class 33 for this trademark*).  
 3,940,854 ( *See Class 33 for this trademark*).  
 3,940,855 ( *See Class 33 for this trademark*).  
 3,940,856 ( *See Class 33 for this trademark*).  
 3,940,857 ( *See Class 33 for this trademark*).  
 3,940,858 ( *See Class 33 for this trademark*).  
 3,940,859 ( *See Class 33 for this trademark*).  
 3,940,860 ( *See Class 33 for this trademark*).  
 3,940,861 ( *See Class 33 for this trademark*).  
 3,940,862 ( *See Class 33 for this trademark*).  
 3,940,863 ( *See Class 33 for this trademark*).  
 3,940,864 ( *See Class 33 for this trademark*).  
 3,940,865 ( *See Class 33 for this trademark*).  
 3,940,866 ( *See Class 33 for this trademark*).  
 3,940,867 ( *See Class 33 for this trademark*).  
 3,940,868 ( *See Class 33 for this trademark*).  
 3,940,869 ( *See Class 33 for this trademark*).  
 3,940,870 ( *See Class 33 for this trademark*).  
 3,940,871 ( *See Class 33 for this trademark*).  
 3,940,872 ( *See Class 33 for this trademark*).  
 3,940,873 ( *See Class 33 for this trademark*).  
 3,940,874 ( *See Class 33 for this trademark*).  
 3,940,875 ( *See Class 33 for this trademark*).  
 3,940,876 ( *See Class 33 for this trademark*).  
 3,940,877 ( *See Class 33 for this trademark*).  
 3,940,878 ( *See Class 33 for this trademark*).  
 3,940,879 ( *See Class 33 for this trademark*).  
 3,940,880 ( *See Class 33 for this trademark*).  
 3,940,881 ( *See Class 33 for this trademark*).  
 3,940,882 ( *See Class 33 for this trademark*).  
 3,940,883 ( *See Class 33 for this trademark*).  
 3,940,884 ( *See Class 33 for this trademark*).  
 3,940,885 ( *See Class 33 for this trademark*).  
 3,940,886 ( *See Class 33 for this trademark*).  
 3,940,887 ( *See Class 33 for this trademark*).  
 3,940,888 ( *See Class 33 for this trademark*).  
 3,940,889 ( *See Class 33 for this trademark*).  
 3,940,890 ( *See Class 33 for this trademark*).  
 3,940,891 ( *See Class 33 for this trademark*).  
 3,940,892 ( *See Class 33 for this trademark*).  
 3,940,893 ( *See Class 33 for this trademark*).  
 3,940,894 ( *See Class 33 for this trademark*).  
 3,940,895 ( *See Class 33 for this trademark*).  
 3,940,896 ( *See Class 33 for this trademark*).  
 3,940,897 ( *See Class 33 for this trademark*).  
 3,940,898 ( *See Class 33 for this trademark*).  
 3,940,899 ( *See Class 33 for this trademark*).  
 3,940,900 ( *See Class 33 for this trademark*).  
 3,940,901 ( *See Class 33 for this trademark*).  
 3,940,902 ( *See Class 33 for this trademark*).  
 3,940,903 ( *See Class 33 for this trademark*).  
 3,940,904 ( *See Class 33 for this trademark*).  
 3,940,905 ( *See Class 33 for this trademark*).  
 3,940,906 ( *See Class 33 for this trademark*).  
 3,940,907 ( *See Class 33 for this trademark*).  
 3,940,908 ( *See Class 33 for this trademark*).  
 3,940,909 ( *See Class 33 for this trademark*).  
 3,940,910 ( *See Class 33 for this trademark*).  
 3,940,911 ( *See Class 33 for this trademark*).  
 3,940,912 ( *See Class 33 for this trademark*).  
 3,940,913 ( *See Class 33 for this trademark*).  
 3,940,914 ( *See Class 33 for this trademark*).  
 3,940,915 ( *See Class 33 for this trademark*).  
 3,940,916 ( *See Class 33 for this trademark*).  
 3,940,917 ( *See Class 33 for this trademark*).  
 3,940,918 ( *See Class 33 for this trademark*).  
 3,940,919 ( *See Class 33 for this trademark*).  
 3,940,920 ( *See Class 33 for this trademark*).  
 3,940,921 ( *See Class 33 for this trademark*).  
 3,940,922 ( *See Class 33 for this trademark*).  
 3,940,923 ( *See Class 33 for this trademark*).  
 3,940,924 ( *See Class 33 for this trademark*).  
 3,940,925 ( *See Class 33 for this trademark*).  
 3,940,926 ( *See Class 33 for this trademark*).  
 3,940,927 ( *See Class 33 for this trademark*).  
 3,940,928 ( *See Class 33 for this trademark*).  
 3,940,929 ( *See Class 33 for this trademark*).  
 3,940,930 ( *See Class 33 for this trademark*).  
 3,940,931 ( *See Class 33 for this trademark*).  
 3,940,932 ( *See Class 33 for this trademark*).  
 3,940,933 ( *See Class 33 for this trademark*).  
 3,940,934 ( *See Class 33 for this trademark*).  
 3,940,935 ( *See Class 33 for this trademark*).  
 3,940,936 ( *See Class 33 for this trademark*).  
 3,940,937 ( *See Class 33 for this trademark*).  
 3,940,938 ( *See Class 33 for this trademark*).  
 3,940,939 ( *See Class 33 for this trademark*).  
 3,940,940 ( *See Class 33 for this trademark*).  
 3,940,941 ( *See Class 33 for this trademark*).  
 3,940,942 ( *See Class 33 for this trademark*).  
 3,940,943 ( *See Class 33 for this trademark*).  
 3,940,944 ( *See Class 33 for this trademark*).  
 3,940,945 ( *See Class 33 for this trademark*).  
 3,940,946 ( *See Class 33 for this trademark*).  
 3,940,947 ( *See Class 33 for this trademark*).  
 3,940,948 ( *See Class 33 for this trademark*).  
 3,940,949 ( *See Class 33 for this trademark*).  
 3,940,950 ( *See Class 33 for this trademark*).  
 3,940,951 ( *See Class 33 for this trademark*).  
 3,940,952 ( *See Class 33 for this trademark*).  
 3,940,953 ( *See Class 33 for this trademark*).  
 3,940,954 ( *See Class 33 for this trademark*).  
 3,940,955 ( *See Class 33 for this trademark*).  
 3,940,956 ( *See Class 33 for this trademark*).  
 3,940,957 ( *See Class 33 for this trademark*).  
 3,940,958 ( *See Class 33 for this trademark*).  
 3,940,959 ( *See Class 33 for this trademark*).  
 3,940,960 ( *See Class 33 for this trademark*).  
 3,940,961 ( *See Class 33 for this trademark*).  
 3,940,962 ( *See Class 33 for this trademark*).  
 3,940,963 ( *See Class 33 for this trademark*).  
 3,940,964 ( *See Class 33 for this trademark*).  
 3,940,965 ( *See Class 33 for this trademark*).  
 3,940,966 ( *See Class 33 for this trademark*).  
 3,940,967 ( *See Class 33 for this trademark*).  
 3,940,968 ( *See Class 33 for this trademark*).  
 3,940,969 ( *See Class 33 for this trademark*).  
 3,940,970 ( *See Class 33 for this trademark*).  
 3,940,971 ( *See Class 33 for this trademark*).  
 3,940,972 ( *See Class 33 for this trademark*).  
 3,940,973 ( *See Class 33 for this trademark*).  
 3,940,974 ( *See Class 33 for this trademark*).  
 3,940,975 ( *See Class 33 for this trademark*).  
 3,940,976 ( *See Class 33 for this trademark*).  
 3,940,977 ( *See Class 33 for this trademark*).  
 3,940,978 ( *See Class 33 for this trademark*).  
 3,940,979 ( *See Class 33 for this trademark*).  
 3,940,980 ( *See Class 33 for this trademark*).  
 3,940,981 ( *See Class 33 for this trademark*).  
 3,940,982 ( *See Class 33 for this trademark*).  
 3,940,983 ( *See Class 33 for this trademark*).  
 3,940,984 ( *See Class 33 for this trademark*).  
 3,940,985 ( *See Class 33 for this trademark*).  
 3,940,986 ( *See Class 33 for this trademark*).  
 3,940,987 ( *See Class 33 for this trademark*).  
 3,940,988 ( *See Class 33 for this trademark*).  
 3,940,989 ( *See Class 33 for this trademark*).  
 3,940,990 ( *See Class 33 for this trademark*).  
 3,940,991 ( *See Class 33 for this trademark*).  
 3,940,992 ( *See Class 33 for this trademark*).  
 3,940,993 ( *See Class 33 for this trademark*).  
 3,940,994 ( *See Class 33 for this trademark*).  
 3,940,995 ( *See Class 33 for this trademark*).  
 3,940,996 ( *See Class 33 for this trademark*).  
 3,940,997 ( *See Class 33 for this trademark*).  
 3,940,998 ( *See Class 33 for this trademark*).  
 3,940,999 ( *See Class 33 for this trademark*).  
 3,941,000 ( *See Class 33 for this trademark*).

### CLASS 34—SMOKERS' ARTICLES

3,939,487. **CONSTANZA (STANDARD CHARACTER)**. LA TABACALERA, C. POR A., (U.S. CLS. 2, 8, 9 AND 17). SN 77-751,905. PUB. 1-18-2011. FILED 6-4-2009.  
 3,939,660. **BUZZSAW (STANDARD CHARACTER)**. SOCIAL SMOKE, INC., (U.S. CLS. 2, 8, 9 AND 17). SN 77-923,413. PUB. 1-18-2011. FILED 1-29-2010.  
 3,939,969 ( *See Class 9 for this trademark*).  
 3,940,026 ( *See Class 14 for this trademark*).  
 3,940,115. **DOUBLE HAPPINESS (SONG HIE) AND DESIGN**. N.V. SUMATRA TOBACCO TRADING COMPANY, (U.S. CLS. 2, 8, 9 AND 17). SN 85-016,932. PUB. 1-18-2011. FILED 4-19-2010.  
 3,940,575. **EROTIC CIGAR AND DESIGN**. Z CIGAR INTERNATIONAL, LLC, (U.S. CLS. 2, 8, 9 AND 17). SN 85-098,996. PUB. 1-18-2011. FILED 8-3-2010.  
 3,940,785. **FLOR DE PANAMA (STANDARD CHARACTER)**. SEACOI INVESTMENTS, INC., (U.S. CLS. 2, 8, 9 AND 17).

SN 85-102,062. PUB. 1-18-2011. FILED 8-6-2010.  
 3,940,893. **FDW (STANDARD CHARACTER)**. ARGANESE INTERNATIONAL, LLC, (U.S. CLS. 2, 8, 9 AND 17). SN 85-112,017. PUB. 1-18-2011. FILED 8-20-2010.

## SERVICE MARKS

### CLASS 35—ADVERTISING AND BUSINESS

- 3,939,370. **ALL AMERICAN STORE (STANDARD CHARACTER)**. ALL AMERICAN STORE, LLC, (U.S. CLS. 100, 101 AND 102). SN 76-702,361. PUB. 1-18-2011. FILED 4-5-2010.
- 3,939,372. **INTERNATIONAL WINDOW COVERINGS EXPO (STANDARD CHARACTER)**. GRACE MCNAMARA, INC., (U.S. CLS. 100, 101 AND 102). SN 76-702,665. PUB. 1-18-2011. FILED 4-26-2010.
- 3,939,383. **H.O.T. (STANDARD CHARACTER)**. BUCKNER & COMPANY, INC., (U.S. CLS. 100, 101 AND 102). SN 76-703,924. PUB. 1-18-2011. FILED 7-27-2010.
- 3,939,384. **H.O.T. CULTURE (STANDARD CHARACTER)**. BUCKNER & COMPANY, INC., (U.S. CLS. 100, 101 AND 102). SN 76-703,925. PUB. 1-18-2011. FILED 7-27-2010.
- 3,939,394 ( *See Class 16 for this trademark*).
- 3,939,407. **HALCYON DESIGN (STANDARD CHARACTER)**. HALCYON DESIGN LLC, DBA HALCYON DESIGN, (U.S. CLS. 100, 101 AND 102). SN 77-309,963. PUB. 1-18-2011. FILED 10-22-2007.
- 3,939,415. **DAVINCI (STANDARD CHARACTER)**. DAVINCI SELECTWORK LLC, (U.S. CLS. 100, 101 AND 102). SN 77-408,937. PUB. 1-18-2011. FILED 2-28-2008.
- 3,939,431. **WITHERS (STANDARD CHARACTER)**. WITHERS LLP, MULTIPLE CLASS, (INT. CLS. 35, 36 AND 45), (U.S. CLS. 100, 101 AND 102). SN 77-550,385. PUB. 1-18-2011. FILED 8-19-2008.
- 3,939,432. **WITHERS AND DESIGN**. WITHERS LLP, MULTIPLE CLASS, (INT. CLS. 35, 36 AND 45), (U.S. CLS. 100, 101 AND 102). SN 77-550,535. PUB. 1-18-2011. FILED 8-19-2008.
- 3,939,443. **NOCC (STANDARD CHARACTER)**. NATIONAL OVARIAN CANCER COALITION, INC., MULTIPLE CLASS, (INT. CLS. 35, 44 AND 45), (U.S. CLS. 100, 101 AND 102). SN 77-630,979. PUB. 1-18-2011. FILED 12-11-2008.
- 3,939,444. **NATIONAL OVARIAN CANCER COALITION (STANDARD CHARACTER)**. NATIONAL OVARIAN CANCER COALITION, INC., MULTIPLE CLASS, (INT. CLS. 35, 44 AND 45), (U.S. CLS. 100, 101 AND 102). SN 77-631,098. PUB. 1-18-2011. FILED 12-11-2008.
- 3,939,445. **NOCC NATIONAL OVARIAN CANCER COALITION AND DESIGN**. NATIONAL OVARIAN CANCER COALITION, INC., MULTIPLE CLASS, (INT. CLS. 35, 44 AND 45), (U.S. CLS. 100, 101 AND 102). SN 77-631,133. PUB. 1-18-2011. FILED 12-11-2008.
- 3,939,448. **MICHIGAN GAS UTILITIES AND DESIGN**. MICHIGAN GAS UTILITIES CORPORATION, MULTIPLE CLASS, (INT. CLS. 35, 36, 37, 39 AND 42), (U.S. CLS. 100, 101, 102, 103, 105 AND 106). SN 77-638,349. PUB. 1-18-2011. FILED 12-22-2008.
- 3,939,449 ( *See Class 18 for this trademark*).
- 3,939,475. **PIONEERS - FOR A CURE - SONGS TO FIGHT CANCER AND DESIGN**. JOODAYOH, INC., (U.S. CLS. 100, 101 AND 102). SN 77-728,888. PUB. 4-6-2010. FILED 5-5-2009.
- 3,939,476. **THE O ZONE AND DESIGN**. PLEIN, EDWARD, (U.S. CLS. 100, 101 AND 102). SN 77-732,956. PUB. 1-18-2011. FILED 5-8-2009.
- 3,939,486. **H-E-B MOBILE TALK ABOUT CONVENIENT. AND DESIGN**. HEB GROCERY COMPANY, LP, (U.S. CLS. 100, 101 AND 102). SN 77-751,839. PUB. 1-18-2011. FILED 6-4-2009.
- 3,939,504. **CEAAS CHANNEL ENABLEMENT AS A SERVICE (STYLIZED)**. CHANNEL MECHANICS LIMITED, MULTIPLE CLASS, (INT. CLS. 35 AND 42), (U.S. CLS. 100, 101 AND 102). SN 77-785,669. PUB. 1-18-2011. FILED 7-21-2009.
- 3,939,505. **VIRTUAL ENTITLEMENT VOUCHER V AND DESIGN**. CHANNEL MECHANICS LIMITED, MULTIPLE CLASS, (INT. CLS. 35 AND 42), (U.S. CLS. 100, 101 AND 102). SN 77-785,707. PUB. 1-18-2011. FILED 7-21-2009.
- 3,939,506 ( *See Class 9 for this trademark*).
- 3,939,514 ( *See Class 18 for this trademark*).
- 3,939,516 ( *See Class 9 for this trademark*).
- 3,939,520. **STAYING SANE (STANDARD CHARACTER)**. STAYING SANE, LLC, (U.S. CLS. 100, 101 AND 102). SN 77-797,075. PUB. 1-18-2011. FILED 8-4-2009.
- 3,939,521. **MISCELLANEOUS DESIGN**. RHO, INC., MULTIPLE CLASS, (INT. CLS. 35, 41 AND 42), (U.S. CLS. 100, 101, 102 AND 107). SN 77-797,393. PUB. 1-18-2011. FILED 8-5-2009.
- 3,939,522. **GIVING FLIGHT TO RESEARCH (STANDARD CHARACTER)**. RHO, INC., MULTIPLE CLASS, (INT. CLS. 35, 41 AND 42), (U.S. CLS. 100, 101, 102 AND 107). SN 77-797,401. PUB. 1-18-2011. FILED 8-5-2009.
- 3,939,523. **LOGIXDATA (STANDARD CHARACTER)**. TWO-MO CORP., DBA LOGIXDATA, (U.S. CLS. 100, 101 AND 102). SN 77-798,481. PUB. 1-18-2011. FILED 8-6-2009.
- 3,939,527. **Q AND DESIGN**. QUAIL HOLLOW COUNTRY CLUB, MULTIPLE CLASS, (INT. CLS. 35 AND 41), (U.S. CLS. 100, 101, 102 AND 107). SN 77-807,885. PUB. 1-18-2011. FILED 8-19-2009.
- 3,939,538. **USER INSIGHT (STYLIZED)**. USER INSIGHT, INC., MULTIPLE CLASS, (INT. CLS. 35 AND 42), (U.S. CLS. 100, 101 AND 102). SN 77-815,114. PUB. 1-18-2011. FILED 8-28-2009.
- 3,939,540. **COUNTRY CLUB SUPPLY (STANDARD CHARACTER)**. COUNTRY CLUB SUPPLY, INC., (U.S. CLS. 100, 101 AND 102). SN 77-819,845. PUB. 1-18-2011. FILED 9-3-2009.
- 3,939,552. **THE CHANCE PHELPS FOUNDATION (STANDARD CHARACTER)**. MACK GRETCHEN, (U.S. CLS. 100, 101 AND 102). SN 77-838,984. PUB. 1-18-2011. FILED 10-1-2009.
- 3,939,553. **COAST TO COAST (STANDARD CHARACTER)**. COAST TO COAST HEALTHCARE SERVICES INCORPORATED, (U.S. CLS. 100, 101 AND 102). SN 77-839,166. PUB. 1-18-2011. FILED 10-1-2009.
- 3,939,555. **STOREMORE AND DESIGN**. LF, LLC, (U.S. CLS. 100, 101 AND 102). SN 77-846,510. PUB. 1-18-2011. FILED 10-12-2009.
- 3,939,556. **STOREMORE (STANDARD CHARACTER)**. LF, LLC, (U.S. CLS. 100, 101 AND 102). SN 77-846,513. PUB. 1-18-2011. FILED 10-12-2009.
- 3,939,558. **USEF UNITED STATES EQUESTRIAN FEDERATION AND DESIGN**. UNITED STATES EQUESTRIAN FEDERATION, INC., MULTIPLE CLASS, (INT. CLS. 35 AND 42), (U.S. CLS. 100, 101 AND 102). SN 77-847,206. PUB. 1-18-2011. FILED 10-13-2009.
- 3,939,574. **KULI MELA (STANDARD CHARACTER)**. KULI MELA ASSOCIATION, (U.S. CLS. 100, 101 AND 102). SN 77-861,902. PUB. 1-18-2011. FILED 10-30-2009.
- 3,939,575. **SCHOEPP MOTORS (STANDARD CHARACTER)**. SCHOEPP MOTORS, INC., (U.S. CLS. 100, 101 AND 102). SN 77-864,057. PUB. 1-18-2011. FILED 11-3-2009.
- 3,939,583. **VENTURE (STANDARD CHARACTER)**. AFFILIATED FOODS, INC., (U.S. CLS. 100, 101 AND 102). SN 77-870,525. PUB. 1-18-2011. FILED 11-11-2009.
- 3,939,584. **SQUIRREL EASYCARE (STANDARD CHARACTER)**. SQUIRREL SYSTEMS, G.P., MULTIPLE CLASS, (INT. CLS. 35, 41 AND 42), (U.S. CLS. 100, 101, 102 AND 107). SN 77-871,232. PUB. 1-18-2011. FILED 11-12-2009.
- 3,939,602. **TRUE INNOVATORS (STANDARD CHARACTER)**. DARREL EDWARDS INC., (U.S. CLS. 100, 101 AND 102). SN 77-891,407. PUB. 1-18-2011. FILED 12-11-2009.
- 3,939,604. **FARM & FLEET (STANDARD CHARACTER)**. BLAIN SUPPLY, INC., (U.S. CLS. 100, 101 AND 102). SN 77-894,812. PUB. 5-18-2010. FILED 12-16-2009.
- 3,939,627. **SHOPPING THAT PAYS YOU BACK (STANDARD CHARACTER)**. REZNIK CORPORATION, DBA BOOMERANG PAYS, (U.S. CLS. 100, 101 AND 102). SN 77-914,708. PUB. 1-18-2011. FILED 1-19-2010.
- 3,939,629 ( *See Class 3 for this trademark*).
- 3,939,632 ( *See Class 3 for this trademark*).
- 3,939,633. **LIE LONG ISLAND ELITE AND DESIGN**. LONG ISLAND NETWORKING ELITE, (U.S. CLS. 100, 101 AND 102). SN 77-915,575. PUB. 1-18-2011. FILED 1-20-2010.
- 3,939,639. **ISLAND FRESH BUY LOCAL IT MATTERS JOIN THE MOVEMENT! AND DESIGN**. DEPARTMENT OF

- AGRICULTURE, (U.S. CLS. 100, 101 AND 102). SN 77-918,530. PUB. 1-18-2011. FILED 1-22-2010.
- 3,939,643. **VISCIRA AND DESIGN**. VISCIRA, LLC, MULTIPLE CLASS, (INT. CLS. 35 AND 42), (U.S. CLS. 100, 101 AND 102). SN 77-919,858. PUB. 1-18-2011. FILED 1-25-2010.
- 3,939,651. **RECYCLED BRIDE (STANDARD CHARACTER)**. DINUNZIO, TRACY, (U.S. CLS. 100, 101 AND 102). SN 77-922,053. PUB. 1-18-2011. FILED 1-28-2010.
- 3,939,652. **FREEDOMPHONE (STANDARD CHARACTER)**. TOIV, SHRAGE, (U.S. CLS. 100, 101 AND 102). SN 77-922,232. PUB. 1-18-2011. FILED 1-28-2010.
- 3,939,654. **JAMISON (STANDARD CHARACTER)**. HERBERT L. JAMISON & CO., LLC, MULTIPLE CLASS, (INT. CLS. 35 AND 36), (U.S. CLS. 100, 101 AND 102). SN 77-922,570. PUB. 1-18-2011. FILED 1-28-2010.
- 3,939,656. **AMERICAN MEDICAL INFORMATICS ASSOCIATION (STANDARD CHARACTER)**. AMERICAN MEDICAL INFORMATICS ASSOCIATION, INC., MULTIPLE CLASS, (INT. CLS. 35 AND 41), (U.S. CLS. 100, 101, 102 AND 107). SN 77-922,867. PUB. 1-18-2011. FILED 1-28-2010.
- 3,939,662. **323.TV (STANDARD CHARACTER)**. 323.TV LLC, MULTIPLE CLASS, (INT. CLS. 35 AND 37), (U.S. CLS. 100, 101, 102, 103 AND 106). SN 77-924,020. PUB. 1-18-2011. FILED 1-29-2010.
- 3,939,663. **MISCELLANEOUS DESIGN**. 323.TV LLC, MULTIPLE CLASS, (INT. CLS. 35 AND 37), (U.S. CLS. 100, 101, 102, 103 AND 106). SN 77-924,027. PUB. 1-18-2011. FILED 1-29-2010.
- 3,939,665. **CHANGEMAKERS (STANDARD CHARACTER)**. ASHOKA: INNOVATORS FOR THE PUBLIC, MULTIPLE CLASS, (INT. CLS. 35 AND 41), (U.S. CLS. 100, 101, 102 AND 107). SN 77-924,087. PUB. 1-18-2011. FILED 1-29-2010.
- 3,939,667. **ECOSTASY (STANDARD CHARACTER)**. PONTE NYC LLC, DBA ECOSTASY, (U.S. CLS. 100, 101 AND 102). SN 77-924,157. PUB. 1-18-2011. FILED 1-29-2010.
- 3,939,669. **AMERICAN STREET ROD ASSOCIATION (STANDARD CHARACTER)**. WITHERS, MICHAEL WAYNE, (U.S. CLS. 100, 101 AND 102). SN 77-924,442. PUB. 12-14-2010. FILED 1-31-2010.
- 3,939,676. **HEADCHANGE (STANDARD CHARACTER)**. CROSS, STEVEN MICHAEL, DBA HEADCHANGE INTERNATIONAL, (U.S. CLS. 100, 101 AND 102). SN 77-928,361. PUB. 1-18-2011. FILED 2-4-2010.
- 3,939,683. **GUILTY PLEASURES CLUB (STYLIZED)**. YATVIN, MICHAEL, DBA HEYMO PRODUCTIONS, AND HOROWITZ, PAMELA, DBA HEYMO PRODUCTIONS, (U.S. CLS. 100, 101 AND 102). SN 77-929,159. PUB. 1-18-2011. FILED 2-5-2010.
- 3,939,686. **GOOD PEOPLE (STANDARD CHARACTER)**. GOOD PEOPLE, INC., (U.S. CLS. 100, 101 AND 102). SN 77-929,608. PUB. 1-18-2011. FILED 2-5-2010.
- 3,939,693. **BLUEVIA (STANDARD CHARACTER)**. TELEFONICA, S.A., MULTIPLE CLASS, (INT. CLS. 35, 38 AND 42), (U.S. CLS. 100, 101, 102 AND 104). SN 77-930,587. PUB. 1-18-2011. FILED 2-8-2010.
- 3,939,724. **AOD ANALYTIX ON DEMAND AND DESIGN**. ANALYTIX ON DEMAND, INC., (U.S. CLS. 100, 101 AND 102). SN 77-936,384. PUB. 1-18-2011. FILED 2-16-2010.
- 3,939,730 ( *See Class 16 for this trademark*).
- 3,939,735. **WHEELHOUSE (STANDARD CHARACTER)**. WHEELHOUSE INVESTMENT REAL ESTATE BROKERAGE, INC., (U.S. CLS. 100, 101 AND 102). SN 77-936,979. PUB. 1-18-2011. FILED 2-16-2010.
- 3,939,741. **BRAD SUGARS (STANDARD CHARACTER)**. ACTIONCOACH LIMITED, (U.S. CLS. 100, 101 AND 102). SN 77-938,560. PUB. 1-18-2011. FILED 2-18-2010.
- 3,939,745. **SOULSPACE (STANDARD CHARACTER)**. TEMPLEHOME MEDIA, LLC, (U.S. CLS. 100, 101 AND 102). SN 77-939,442. PUB. 1-18-2011. FILED 2-18-2010.
- 3,939,747 ( *See Class 16 for this trademark*).
- 3,939,749. **KC PREFERRED (STANDARD CHARACTER)**. KC PREFERRED, LLC, (U.S. CLS. 100, 101 AND 102). SN 77-939,972. PUB. 1-18-2011. FILED 2-19-2010.
- 3,939,752. **STRASSBURGER MEATS AGED TO PERFECTION FOR FIVE GENERATIONS AND DESIGN**. STRASSBURGER MEATS LLC, (U.S. CLS. 100, 101 AND 102). SN 77-940,061. PUB. 1-18-2011. FILED 2-19-2010.
- 3,939,765. **ON TOP RESULTS (STANDARD CHARACTER)**. ON TOP RESULTS INC., (U.S. CLS. 100, 101 AND 102). SN 77-943,897. PUB. 1-18-2011. FILED 2-24-2010.
- 3,939,768. **C CASCADE CENTERS INCORPORATED AND DESIGN**. CASCADE CENTERS, INCORPORATED, DBA CASCADE EAP, (U.S. CLS. 100, 101 AND 102). SN 77-945,146. PUB. 1-18-2011. FILED 2-25-2010.
- 3,939,777 ( *See Class 9 for this trademark*).
- 3,939,789. **PAGETORRENT (STANDARD CHARACTER)**. DAC GROUP (HOLDINGS) LIMITED, (U.S. CLS. 100, 101 AND 102). SN 77-950,483. PUB. 1-18-2011. FILED 3-4-2010.
- 3,939,802. **APT 3 AND DESIGN**. APT3 PHOTOGRAPHY LLC, MULTIPLE CLASS, (INT. CLS. 35, 40 AND 41), (U.S. CLS. 100, 101, 102, 103, 106 AND 107). SN 77-954,473. PUB. 1-18-2011. FILED 3-9-2010.
- 3,939,808. **LET'S GO EXPLORING! (STANDARD CHARACTER)**. HOUGARDY, MARK D, DBA GLYPHGUY LLC, (U.S. CLS. 100, 101 AND 102). SN 77-956,109. PUB. 1-18-2011. FILED 3-10-2010.
- 3,939,812. **JOHN DALY PIZZA JOHN DALY GRIP IT & EAT IT AND DESIGN**. PERKY'S FOODSERVICE CONCEPTS, INC., (U.S. CLS. 100, 101 AND 102). SN 77-957,365. PUB. 1-18-2011. FILED 3-12-2010.
- 3,939,813. **UTILITY CONCIERGE AND DESIGN**. UTILITY CONCIERGE, LLC, MULTIPLE CLASS, (INT. CLS. 35 AND 45), (U.S. CLS. 100, 101 AND 102). SN 77-957,530. PUB. 1-18-2011. FILED 3-12-2010.
- 3,939,818. **THE LIFESTYLE GALLERIA (STANDARD CHARACTER)**. THE COLLECTOR CAR NETWORK, INC., (U.S. CLS. 100, 101 AND 102). SN 77-959,444. PUB. 1-18-2011. FILED 3-15-2010.
- 3,939,823. **1ST RATE RÉSUMÉS (STYLIZED)**. GEARY, SUSAN, (U.S. CLS. 100, 101 AND 102). SN 77-959,905. PUB. 1-18-2011. FILED 3-16-2010.
- 3,939,825. **WILLOW GROVE PARK (STANDARD CHARACTER)**. W. G. PARK, L.P., MULTIPLE CLASS, (INT. CLS. 35 AND 36), (U.S. CLS. 100, 101 AND 102). SN 77-961,116. PUB. 1-18-2011. FILED 3-17-2010.
- 3,939,826. **WILLOW GROVE PARK AND DESIGN**. W. G. PARK, L.P., MULTIPLE CLASS, (INT. CLS. 35 AND 36), (U.S. CLS. 100, 101 AND 102). SN 77-961,173. PUB. 1-18-2011. FILED 3-17-2010.
- 3,939,838 ( *See Class 16 for this trademark*).
- 3,939,850. **JOURNEY TO THE EMERALD CITY (STANDARD CHARACTER)**. PARTNERS IN LEADERSHIP IP, LLC, MULTIPLE CLASS, (INT. CLS. 35 AND 41), (U.S. CLS. 100, 101, 102 AND 107). SN 77-966,015. PUB. 1-18-2011. FILED 3-23-2010.
- 3,939,856. **ANTIQUERA (STANDARD CHARACTER)**. SAYEGH, JOSEPH, (U.S. CLS. 100, 101 AND 102). SN 77-967,810. PUB. 1-18-2011. FILED 3-24-2010.
- 3,939,861. **TRUCKERLINK (STANDARD CHARACTER)**. SIGNALSET, INC., (U.S. CLS. 100, 101 AND 102). SN 77-980,913. PUB. 1-18-2011. FILED 2-3-2010.
- 3,939,870 ( *See Class 29 for this trademark*).
- 3,939,877. **WASHINGTON TALENT AGENCY (STANDARD CHARACTER)**. B & J ENTERPRISES, LTD, (U.S. CLS. 100, 101 AND 102). SN 78-925,756. PUB. 12-25-2007. FILED 7-10-2006.
- 3,939,890 ( *See Class 9 for this trademark*).
- 3,939,891. **DUBAI INTERNATIONAL CAPITAL AND DESIGN**. DUBAI INTERNATIONAL CAPITAL LLC, MULTIPLE CLASS, (INT. CLS. 35 AND 36), (U.S. CLS. 100, 101 AND 102). SN 79-068,194. PUB. 1-18-2011. FILED 3-17-2009.
- 3,939,894. **APOTECA NATURA AND DESIGN**. ABOCA S.P.A. SOCIETA' AGRICOLA, MULTIPLE CLASS, (INT. CLS. 35 AND 42), (U.S. CLS. 100, 101 AND 102). SN 79-070,160. PUB. 1-18-2011. FILED 2-9-2009.
- 3,939,898 ( *See Class 9 for this trademark*).
- 3,939,901. **GOOD SMELL. GOOD CURRY COCOICHIBANYA CURRY HOUSE COCO AND DESIGN**. ICHIBANYA CO., LTD., MULTIPLE CLASS, (INT. CLS. 35, 36 AND 43), (U.S. CLS. 100, 101 AND 102). SN 79-072,451. PUB. 1-18-2011. FILED 4-1-2009.
- 3,939,902. **MISCELLANEOUS DESIGN**. DEUTSCHE GESELLSCHAFT FÜR NACHHALTIGES BAUEN E.V., MULTIPLE CLASS, (INT. CLS. 35, 37, 41 AND 42), (U.S. CLS. 100, 101, 102, 103, 106 AND 107). SN 79-072,828. PUB. 1-18-2011. FILED 1-23-2009.

- 3,939,904 ( *See Class 9 for this trademark* ).  
 3,939,908 ( *See Class 25 for this trademark* ).  
 3,939,910 ( *See Class 9 for this trademark* ).  
 3,939,915. **HLL HANSEATIC LLOYD (STYLIZED)**. HANSEATIC LLOYD AG, MULTIPLE CLASS, (INT. CLS. 35, 36, 39 AND 42), (U.S. CLS. 100, 101, 102 AND 105). SN 79-074,675. PUB. 1-18-2011. FILED 6-19-2009.  
 3,939,920 ( *See Class 9 for this trademark* ).  
 3,939,921 ( *See Class 9 for this trademark* ).  
 3,939,922 ( *See Class 14 for this trademark* ).  
 3,939,925 ( *See Class 9 for this trademark* ).  
 3,939,928 ( *See Class 16 for this trademark* ).  
 3,939,931 ( *See Class 14 for this trademark* ).  
 3,939,936 ( *See Class 3 for this trademark* ).  
 3,939,939 ( *See Class 9 for this trademark* ).  
 3,939,964. **MYUPDATE (STANDARD CHARACTER)**. MYUPDATE DA, MULTIPLE CLASS, (INT. CLS. 35, 38 AND 39), (U.S. CLS. 100, 101, 102, 104 AND 105). SN 79-080,442. PUB. 1-18-2011. FILED 12-19-2009.  
 3,939,967 ( *See Class 25 for this trademark* ).  
 3,939,971 ( *See Class 9 for this trademark* ).  
 3,939,972. **NORIEM (STYLIZED)**. MATSUO SANGYO CO., LTD., (U.S. CLS. 100, 101 AND 102). SN 79-080,752. PUB. 1-18-2011. FILED 2-5-2010.  
 3,939,973. **APPS LIB (STANDARD CHARACTER)**. ARCHOS, MULTIPLE CLASS, (INT. CLS. 35, 38 AND 42), (U.S. CLS. 100, 101, 102 AND 104). SN 79-080,783. PUB. 1-18-2011. FILED 2-19-2010.  
 3,939,985. **GULLIVER (STYLIZED)**. GULLIVER INTERNATIONAL CO., LTD., (U.S. CLS. 100, 101 AND 102). SN 79-081,201. PUB. 1-18-2011. FILED 2-17-2010.  
 3,939,989 ( *See Class 5 for this trademark* ).  
 3,939,997 ( *See Class 16 for this trademark* ).  
 3,939,999 ( *See Class 6 for this trademark* ).  
 3,940,014 ( *See Class 32 for this trademark* ).  
 3,940,015 ( *See Class 20 for this trademark* ).  
 3,940,026 ( *See Class 14 for this trademark* ).  
 3,940,029 ( *See Class 3 for this trademark* ).  
 3,940,037 ( *See Class 20 for this trademark* ).  
 3,940,056 ( *See Class 9 for this trademark* ).  
 3,940,078. **BRAIN INJURY PEER VISITOR ASSOCIATION AND DESIGN**. BORISKIE, HELEN ANN, DBA BRAIN INJURY PEER VISITOR ASSOCIATION, (U.S. CLS. 100, 101 AND 102). SN 85-000,076. PUB. 1-18-2011. FILED 3-27-2010.  
 3,940,079. **MY WEB HEALTH (STANDARD CHARACTER)**. MEDPEDS ASSOCIATES OF SARASOTA, MULTIPLE CLASS, (INT. CLS. 35 AND 44), (U.S. CLS. 100, 101 AND 102). SN 85-000,650. PUB. 1-18-2011. FILED 3-29-2010.  
 3,940,088 ( *See Class 5 for this trademark* ).  
 3,940,089 ( *See Class 5 for this trademark* ).  
 3,940,092. **NATIONAL FLEET SERVICES AND DESIGN**. NATIONAL FLEET SERVICES, LLC, (U.S. CLS. 100, 101 AND 102). SN 85-006,386. PUB. 1-18-2011. FILED 4-5-2010.  
 3,940,103. **ANGELAPINK'S (STANDARD CHARACTER)**. PIMENTEL, MICHAEL A, (U.S. CLS. 100, 101 AND 102). SN 85-013,350. PUB. 1-18-2011. FILED 4-14-2010.  
 3,940,107. **SURGICAL NOTES AND DESIGN**. SURGICAL NOTES MDP, LP, MULTIPLE CLASS, (INT. CLS. 35 AND 39), (U.S. CLS. 100, 101, 102 AND 105). SN 85-014,134. PUB. 1-18-2011. FILED 4-14-2010.  
 3,940,108. **NOPAB PROTECTING AMERICAN JOBS AND DESIGN**. NATIONAL ORGANIZATION OF PATRIOTIC AMERICAN BUSINESSES INC., (U.S. CLS. 100, 101 AND 102). SN 85-014,890. PUB. 1-18-2011. FILED 4-15-2010.  
 3,940,109 ( *See Class 9 for this trademark* ).  
 3,940,116. **WRITINGCOACH AND DESIGN**. RALSTON-PAYNE ENTERPRISES, LLC, MULTIPLE CLASS, (INT. CLS. 35 AND 41), (U.S. CLS. 100, 101, 102 AND 107). SN 85-016,994. PUB. 1-18-2011. FILED 4-19-2010.  
 3,940,117. **SUSTAINABLE STYLE BY BATINAU DESIGN GROUP AND DESIGN**. BATINAU DESIGN GROUP, INC., (U.S. CLS. 100, 101 AND 102). SN 85-017,401. PUB. 1-18-2011. FILED 4-19-2010.  
 3,940,125. **LOOK IT UP AND DESIGN**. ADCO ADVERTISING AGENCY, INC., MULTIPLE CLASS, (INT. CLS. 35 AND 42), (U.S. CLS. 100, 101 AND 102). SN 85-023,086. PUB. 1-18-2011. FILED 4-26-2010.  
 3,940,132. **CCINTEGRATION (STANDARD CHARACTER)**. CCINTEGRATION INC., (U.S. CLS. 100, 101 AND 102). SN 85-028,030. PUB. 1-18-2011. FILED 5-1-2010.  
 3,940,136. **MISCELLANEOUS DESIGN**. FRIENDS OF MAINE'S SEABIRD ISLANDS, (U.S. CLS. 100, 101 AND 102). SN 85-028,906. PUB. 1-18-2011. FILED 5-3-2010.  
 3,940,137. **INTERSTATE POKER CLUB AND DESIGN**. BAR GAME PROMOTIONS, INC., MULTIPLE CLASS, (INT. CLS. 35 AND 41), (U.S. CLS. 100, 101, 102 AND 107). SN 85-028,913. PUB. 1-18-2011. FILED 5-3-2010.  
 3,940,138. **FRIENDS OF MAINE SEABIRD ISLANDS AND DESIGN**. FRIENDS OF MAINE'S SEABIRD ISLANDS, (U.S. CLS. 100, 101 AND 102). SN 85-028,916. PUB. 1-18-2011. FILED 5-3-2010.  
 3,940,139. **JOIN. PLAY. WIN. (STANDARD CHARACTER)**. BAR GAME PROMOTIONS, INC., MULTIPLE CLASS, (INT. CLS. 35 AND 41), (U.S. CLS. 100, 101, 102 AND 107). SN 85-028,945. PUB. 1-18-2011. FILED 5-3-2010.  
 3,940,147. **PROFITPLAN (STANDARD CHARACTER)**. THOMAS, KENNETH H, DBA K.H. THOMAS ASSOCIATES, (U.S. CLS. 100, 101 AND 102). SN 85-032,285. PUB. 1-18-2011. FILED 5-6-2010.  
 3,940,148 ( *See Class 9 for this trademark* ).  
 3,940,161. **FORISK (STANDARD CHARACTER)**. FORISK CONSULTING, LLC, MULTIPLE CLASS, (INT. CLS. 35, 36 AND 42), (U.S. CLS. 100, 101 AND 102). SN 85-037,773. PUB. 1-18-2011. FILED 5-13-2010.  
 3,940,162. **LIFEPOINT STRATEGIES AND DESIGN**. TECH-SOLUTIONS, LLC, DBA LIFEPOINT STRATEGIES, (U.S. CLS. 100, 101 AND 102). SN 85-037,992. PUB. 1-18-2011. FILED 5-13-2010.  
 3,940,166. **IDENTITY LEAVE A MARK AND DESIGN**. IDENTITY MARKETING & PUBLIC RELATIONS, LLC, (U.S. CLS. 100, 101 AND 102). SN 85-039,710. PUB. 1-18-2011. FILED 5-16-2010.  
 3,940,167. **GIANT STEPS (STANDARD CHARACTER)**. SCS COLLECTIBLES, INC., (U.S. CLS. 100, 101 AND 102). SN 85-039,970. PUB. 1-18-2011. FILED 5-17-2010.  
 3,940,177. **MALL OF AMERICA (STANDARD CHARACTER)**. MOAC MALL HOLDINGS LLC, DBA MALL OF AMERICA, (U.S. CLS. 100, 101 AND 102). SN 85-041,515. PUB. 1-18-2011. FILED 5-18-2010.  
 3,940,178. **QUALIMAE (STANDARD CHARACTER)**. QUALIMAE CORP., (U.S. CLS. 100, 101 AND 102). SN 85-041,723. PUB. 1-18-2011. FILED 5-18-2010.  
 3,940,193. **TIREMONKEY (STANDARD CHARACTER)**. TIREWARE, INC., (U.S. CLS. 100, 101 AND 102). SN 85-046,434. PUB. 1-18-2011. FILED 5-24-2010.  
 3,940,194. **PECFOA (STANDARD CHARACTER)**. CITIZENS FINANCIAL GROUP, INC., DBA CITIZENS BANK, (U.S. CLS. 100, 101 AND 102). SN 85-046,594. PUB. 1-18-2011. FILED 5-24-2010.  
 3,940,197 ( *See Class 10 for this trademark* ).  
 3,940,198. **CREATIVECONNECTS (STANDARD CHARACTER)**. NICKLAS ASSOCIATES, INC., MULTIPLE CLASS, (INT. CLS. 35 AND 41), (U.S. CLS. 100, 101, 102 AND 107). SN 85-048,281. PUB. 1-18-2011. FILED 5-26-2010.  
 3,940,209. **MOVE (STANDARD CHARACTER)**. GLOBAL MOVE MEDIA, LLC, (U.S. CLS. 100, 101 AND 102). SN 85-051,797. PUB. 1-18-2011. FILED 6-1-2010.  
 3,940,211. **THE NATIONAL 9/11 FLAG AND DESIGN**. THE NEW YORK SAYS THANK YOU FOUNDATION, (U.S. CLS. 100, 101 AND 102). SN 85-052,165. PUB. 1-18-2011. FILED 6-1-2010.  
 3,940,212. **ULIKO (STANDARD CHARACTER)**. ULIKO, INC., MULTIPLE CLASS, (INT. CLS. 35 AND 42), (U.S. CLS. 100, 101 AND 102). SN 85-052,839. PUB. 1-18-2011. FILED 6-2-2010.  
 3,940,213 ( *See Class 3 for this trademark* ).  
 3,940,214. **PHASE 3 CONSULTING, LLC. AND DESIGN**. PHASE 3 CONSULTING, LLC., MULTIPLE CLASS, (INT. CLS. 35 AND 36), (U.S. CLS. 100, 101 AND 102). SN 85-053,379. PUB. 1-18-2011. FILED 6-3-2010.  
 3,940,215. **CCTV CAMERA PROS (STANDARD CHARACTER)**. CCTV CAMERA PROS, (U.S. CLS. 100, 101 AND 102). SN 85-054,441. PUB. 1-18-2011. FILED 6-3-2010.  
 3,940,218. **BROOKINGS SOUTH DAKOTA BRING YOUR DREAMS. AND DESIGN**. CITY OF BROOKINGS, SOUTH

- DAKOTA, (U.S. CLS. 100, 101 AND 102). SN 85-055,290. PUB. 1-18-2011. FILED 6-4-2010.
- 3,940,220. **MISCELLANEOUS DESIGN**. WAL-MART STORES, INC., (U.S. CLS. 100, 101 AND 102). SN 85-055,972. PUB. 1-18-2011. FILED 6-7-2010.
- 3,940,221 ( *See Class 9 for this trademark*).
- 3,940,231. **CARBONSAVE FOR GOLF AND DESIGN**. ENVIRONMENTAL & TURF SERVICES, INC., (U.S. CLS. 100, 101 AND 102). SN 85-058,203. PUB. 1-18-2011. FILED 6-9-2010.
- 3,940,234. **FCA AND DESIGN**. FCA, LLC, MULTIPLE CLASS, (INT. CLS. 35, 37, 40 AND 42), (U.S. CLS. 100, 101, 102, 103 AND 106). SN 85-059,315. PUB. 1-18-2011. FILED 6-10-2010.
- 3,940,235. **TELIFI (STANDARD CHARACTER)**. TELIFI, LLC, (U.S. CLS. 100, 101 AND 102). SN 85-059,451. PUB. 1-18-2011. FILED 6-10-2010.
- 3,940,236. **UNITED STATES EVENTING ASSOCIATION (STANDARD CHARACTER)**. UNITED STATES EVENTING ASSOCIATION, MULTIPLE CLASS, (INT. CLS. 35 AND 41), (U.S. CLS. 100, 101, 102 AND 107). SN 85-059,797. PUB. 1-18-2011. FILED 6-10-2010.
- 3,940,241. **AAVSB (STANDARD CHARACTER)**. AMERICAN ASSOCIATION OF VETERINARY STATE BOARDS, (U.S. CLS. 100, 101 AND 102). SN 85-060,899. PUB. 1-18-2011. FILED 6-11-2010.
- 3,940,254. **PREKINDLE (STANDARD CHARACTER)**. PREKINDLE, LLC, MULTIPLE CLASS, (INT. CLS. 35 AND 41), (U.S. CLS. 100, 101, 102 AND 107). SN 85-065,192. PUB. 1-18-2011. FILED 6-17-2010.
- 3,940,255. **NO POWER, NO PROBLEM (STANDARD CHARACTER)**. FEDERAL ALLIANCE OF SAFE HOMES, INC., AKA FLASH, (U.S. CLS. 100, 101 AND 102). SN 85-065,337. PUB. 1-18-2011. FILED 6-17-2010.
- 3,940,263. **FRANK THE FERAL ALLEY CAT ALLIES WWW.ALLEYCAT.ORG AND DESIGN**. ALLEY CAT ALLIES, (U.S. CLS. 100, 101 AND 102). SN 85-066,630. PUB. 1-18-2011. FILED 6-18-2010.
- 3,940,277. **STATESERV (STANDARD CHARACTER)**. STATESERV MEDICAL, LLC, (U.S. CLS. 100, 101 AND 102). SN 85-071,724. PUB. 1-18-2011. FILED 6-25-2010.
- 3,940,294. **TICKETFLY (STANDARD CHARACTER)**. TICKETFLY, INC., (U.S. CLS. 100, 101 AND 102). SN 85-077,170. PUB. 1-18-2011. FILED 7-2-2010.
- 3,940,297. **NV JONES (STANDARD CHARACTER)**. HANSBERRY, ETHEL LOVATA, (U.S. CLS. 100, 101 AND 102). SN 85-078,272. PUB. 1-18-2011. FILED 7-6-2010.
- 3,940,302. **BOOKS AND COOKIES AND DESIGN**. BOOKS AND COOKIES, (U.S. CLS. 100, 101 AND 102). SN 85-078,849. PUB. 1-18-2011. FILED 7-6-2010.
- 3,940,304. **THE LIL' GENIUS KID NEVER 2 LITTLE 2 LEARN AND DESIGN**. GENIUS KIDS DEVELOPMENT, INC., (U.S. CLS. 100, 101 AND 102). SN 85-079,447. PUB. 1-18-2011. FILED 7-7-2010.
- 3,940,305. **TRILOGY AND DESIGN**. TRILOGY GLASS & PACKAGING, INC., (U.S. CLS. 100, 101 AND 102). SN 85-079,872. PUB. 12-14-2010. FILED 7-7-2010.
- 3,940,308. **BEANS&GREENS AND DESIGN**. THE KANSAS CITY BEANS & GREENS PROGRAM, LLC, (U.S. CLS. 100, 101 AND 102). SN 85-080,584. PUB. 1-18-2011. FILED 7-8-2010.
- 3,940,322. **SMARTWAVE (STANDARD CHARACTER)**. SMARTWAVE CONSULTING, LLC, AKA SMARTWAVE, (U.S. CLS. 100, 101 AND 102). SN 85-083,032. PUB. 1-18-2011. FILED 7-13-2010.
- 3,940,329. **RUTH EDELMAN INTEGRATED MARKETING (STANDARD CHARACTER)**. EDELMAN, INC., (U.S. CLS. 100, 101 AND 102). SN 85-084,298. PUB. 1-18-2011. FILED 7-14-2010.
- 3,940,339. **RAKA (STYLIZED)**. RAKA CREATIVE, LLC, (U.S. CLS. 100, 101 AND 102). SN 85-086,325. PUB. 1-18-2011. FILED 7-16-2010.
- 3,940,340. **FASHION TO FIGURE FASHION FOR FIGURES 12-26 (STANDARD CHARACTER)**. B. LANE INCORPORATED, (U.S. CLS. 100, 101 AND 102). SN 85-086,491. PUB. 1-18-2011. FILED 7-16-2010.
- 3,940,343. **RESEARCHYOURBALLOT.ORG VOTE MAKE AN INFORMED VOTE AND DESIGN**. BLOCKER, ADAM P, (U.S. CLS. 100, 101 AND 102). SN 85-086,933. PUB. 1-18-2011. FILED 7-16-2010.
- 3,940,345. **MR. KNIFEGUY (STANDARD CHARACTER)**. L. BRENT AVERETT, DBA MR. KNIFEGUY, LLC, (U.S. CLS. 100, 101 AND 102). SN 85-087,556. PUB. 1-18-2011. FILED 7-19-2010.
- 3,940,347. **UNLIMIT (STANDARD CHARACTER)**. PRASCO, LLC, (U.S. CLS. 100, 101 AND 102). SN 85-087,621. PUB. 1-18-2011. FILED 7-19-2010.
- 3,940,355. **STARTOUT (STANDARD CHARACTER)**. STARTOUT, MULTIPLE CLASS, (INT. CLS. 35 AND 41), (U.S. CLS. 100, 101, 102 AND 107). SN 85-088,520. PUB. 1-18-2011. FILED 7-20-2010.
- 3,940,368. **WOW (STANDARD CHARACTER)**. WORLD ON WHEELS INTERNATIONAL, INC., (U.S. CLS. 100, 101 AND 102). SN 85-090,694. PUB. 1-18-2011. FILED 7-22-2010.
- 3,940,372. **ENGINE AND DESIGN**. ENGINE, LLC, MULTIPLE CLASS, (INT. CLS. 35 AND 45), (U.S. CLS. 100, 101 AND 102). SN 85-091,355. PUB. 1-18-2011. FILED 7-23-2010.
- 3,940,373. **TRIDENTITY (STANDARD CHARACTER)**. ENGINE, LLC, MULTIPLE CLASS, (INT. CLS. 35, 36 AND 45), (U.S. CLS. 100, 101 AND 102). SN 85-091,391. PUB. 1-18-2011. FILED 7-23-2010.
- 3,940,374. **TRIDENTITY SHIELD AND DESIGN**. ENGINE, LLC, MULTIPLE CLASS, (INT. CLS. 35, 36 AND 45), (U.S. CLS. 100, 101 AND 102). SN 85-091,427. PUB. 1-18-2011. FILED 7-23-2010.
- 3,940,390. **SMALLBOX (STANDARD CHARACTER)**. SMALL BOX CONSULTING, INC., MULTIPLE CLASS, (INT. CLS. 35 AND 42), (U.S. CLS. 100, 101 AND 102). SN 85-093,540. PUB. 1-18-2011. FILED 7-27-2010.
- 3,940,400. **MAGIC DRAGON STREET MEET NATIONALS (STANDARD CHARACTER)**. LAKE AREA CHAMBER OF COMMERCE, INC., (U.S. CLS. 100, 101 AND 102). SN 85-094,203. PUB. 1-18-2011. FILED 7-27-2010.
- 3,940,406. **F.P. WINNER LTD. (STANDARD CHARACTER)**. F.P. WINNER LTD., (U.S. CLS. 100, 101 AND 102). SN 85-094,458. PUB. 1-18-2011. FILED 7-28-2010.
- 3,940,407. **THE WINNER DISTRIBUTING COMPANY (STANDARD CHARACTER)**. F.P. WINNER LTD., (U.S. CLS. 100, 101 AND 102). SN 85-094,515. PUB. 1-18-2011. FILED 7-28-2010.
- 3,940,408. **MOVINGIDEAS (STANDARD CHARACTER)**. MOTIONLX, LLC, (U.S. CLS. 100, 101 AND 102). SN 85-094,573. PUB. 1-18-2011. FILED 7-28-2010.
- 3,940,411. **LEVELUP VIDEO GAMES BUY - SELL -TRADE AND DESIGN**. ABREU ENTERTAINMENT LLC, (U.S. CLS. 100, 101 AND 102). SN 85-094,683. PUB. 1-18-2011. FILED 7-28-2010.
- 3,940,412. **WHEAT DON'T NEED YOU GLUTEN FREE AND DESIGN**. WHEAT DON'T NEED YOU INC., (U.S. CLS. 100, 101 AND 102). SN 85-095,127. PUB. 1-18-2011. FILED 7-28-2010.
- 3,940,419. **BIDMOTORS AND DESIGN**. BID MOTORS LLC, (U.S. CLS. 100, 101 AND 102). SN 85-095,513. PUB. 1-18-2011. FILED 7-29-2010.
- 3,940,420. **1986 PINK NATION VICTORIA'S SECRET AND DESIGN**. VICTORIA'S SECRET STORES BRAND MANAGEMENT, INC., (U.S. CLS. 100, 101 AND 102). SN 85-095,542. PUB. 1-18-2011. FILED 7-29-2010.
- 3,940,428. **ELEVATING INFORMATION INTO INTELLIGENCE (STANDARD CHARACTER)**. LANGER RESEARCH ASSOCIATES LLC, (U.S. CLS. 100, 101 AND 102). SN 85-096,218. PUB. 1-18-2011. FILED 7-29-2010.
- 3,940,430. **BOLDPROGRESSIVES.ORG (STANDARD CHARACTER)**. PROGRESSIVE CHANGE CAMPAIGN COMMITTEE, (U.S. CLS. 100, 101 AND 102). SN 85-096,248. PUB. 1-18-2011. FILED 7-29-2010.
- 3,940,431. **MC MULTICORP AVIATION AND DESIGN**. MULTICORP, LLC, (U.S. CLS. 100, 101 AND 102). SN 85-096,286. PUB. 1-18-2011. FILED 7-29-2010.
- 3,940,434. **EAEGIS (STYLIZED)**. MOHAMED MAWJI, (U.S. CLS. 100, 101 AND 102). SN 85-096,506. PUB. 1-18-2011. FILED 7-30-2010.
- 3,940,439. **CAVENDER'S OUTFITTING THE WEST SINCE 1965 (STANDARD CHARACTER)**. CAVENDER INVESTMENT PROPERTIES, LTD., (U.S. CLS. 100, 101 AND 102). SN 85-096,588. PUB. 1-18-2011. FILED 7-30-2010.
- 3,940,446. **GLENWOODCHAMBER.COM (STANDARD CHARACTER)**. GLENWOOD SPRINGS CHAMBER RE-

- SORT ASSOCIATION, INC., (U.S. CLS. 100, 101 AND 102). SN 85-096,854. PUB. 1-18-2011. FILED 7-30-2010.
- 3,940,449. **AN OCCASIONAL CHOCOLATE AND DESIGN.** SANDBERG, CHERYL, AND SANDBERG, BRUCE, (U.S. CLS. 100, 101 AND 102). SN 85-096,882. PUB. 1-18-2011. FILED 7-30-2010.
- 3,940,460. **HELIX DISC GOLF (STANDARD CHARACTER).** BERG, JON, DBA HELIX DISC GOLF, (U.S. CLS. 100, 101 AND 102). SN 85-097,282. PUB. 1-18-2011. FILED 7-30-2010.
- 3,940,493. **PEAK PORTFOLIO (STANDARD CHARACTER).** PEAK PORTFOLIO, INC., (U.S. CLS. 100, 101 AND 102). SN 85-097,621. PUB. 1-18-2011. FILED 8-1-2010.
- 3,940,495. **ALOTTA (STANDARD CHARACTER).** ALOTTA GROUP INC, (U.S. CLS. 100, 101 AND 102). SN 85-097,643. PUB. 1-18-2011. FILED 8-1-2010.
- 3,940,501. **ROARING BROOK ART (STANDARD CHARACTER).** ROARING BROOK ART COMPANY, INC., (U.S. CLS. 100, 101 AND 102). SN 85-097,751. PUB. 1-18-2011. FILED 8-2-2010.
- 3,940,506. **TONE ZONE AND DESIGN.** BOB'S STORES CORP., (U.S. CLS. 100, 101 AND 102). SN 85-097,805. PUB. 1-18-2011. FILED 8-2-2010.
- 3,940,510. **TEENAGE MILLIONAIRE (STANDARD CHARACTER).** DOUGLAS WILLIAMS, (U.S. CLS. 100, 101 AND 102). SN 85-097,931. PUB. 1-18-2011. FILED 8-2-2010.
- 3,940,515. **B BEAMPINES AND DESIGN.** BEAMPINES, INC., (U.S. CLS. 100, 101 AND 102). SN 85-098,018. PUB. 1-18-2011. FILED 8-2-2010.
- 3,940,518. **VIORUM (STANDARD CHARACTER).** NOEMDOE, GERALD, (U.S. CLS. 100, 101 AND 102). SN 85-098,054. PUB. 1-18-2011. FILED 8-2-2010.
- 3,940,525. **FIRST DIGITAL SOLUTIONS (STANDARD CHARACTER).** US LEGAL MANAGEMENT SERVICES, INC., MULTIPLE CLASS, (INT. CLS. 35 AND 42), (U.S. CLS. 100, 101 AND 102). SN 85-098,158. PUB. 1-18-2011. FILED 8-2-2010.
- 3,940,528. **YOUR EXTRA HANDS SURGICAL SERVICES (STANDARD CHARACTER).** EXTRA HANDS SURGICAL SERVICES, LLC, DBA YOUR EXTRA HANDS SURGICAL SERVICES, (U.S. CLS. 100, 101 AND 102). SN 85-098,232. PUB. 1-18-2011. FILED 8-2-2010.
- 3,940,529 ( *See Class 29 for this trademark.* )
- 3,940,543. **FIRST RECORDS RETRIEVAL (STANDARD CHARACTER).** US LEGAL MANAGEMENT SERVICES, INC., MULTIPLE CLASS, (INT. CLS. 35 AND 45), (U.S. CLS. 100, 101 AND 102). SN 85-098,515. PUB. 1-18-2011. FILED 8-2-2010.
- 3,940,544. **THE BRANDING LADY (STANDARD CHARACTER).** LADIES WHO BRAND, INC., (U.S. CLS. 100, 101 AND 102). SN 85-098,517. PUB. 1-18-2011. FILED 8-2-2010.
- 3,940,547. **FIRST LEGAL (STANDARD CHARACTER).** US LEGAL MANAGEMENT SERVICES, INC., MULTIPLE CLASS, (INT. CLS. 35 AND 45), (U.S. CLS. 100, 101 AND 102). SN 85-098,546. PUB. 1-18-2011. FILED 8-2-2010.
- 3,940,551. **NB NATURAL BODY, INC. STRENGTH POWER DISCIPLINE VISION AND DESIGN.** NATURAL BODY INC., (U.S. CLS. 100, 101 AND 102). SN 85-098,624. PUB. 1-18-2011. FILED 8-3-2010.
- 3,940,554. **CHAPFIX+ (STANDARD CHARACTER).** LOTTA LUV, LLC, (U.S. CLS. 100, 101 AND 102). SN 85-098,637. PUB. 1-18-2011. FILED 8-3-2010.
- 3,940,556. **SLEEP EXPRESS (STANDARD CHARACTER).** HOM FURNITURE, INC., (U.S. CLS. 100, 101 AND 102). SN 85-098,656. PUB. 1-18-2011. FILED 8-3-2010.
- 3,940,560. **CAREERCOMMERCIAL (STANDARD CHARACTER).** CAREERBUILDER, LLC, (U.S. CLS. 100, 101 AND 102). SN 85-098,758. PUB. 1-18-2011. FILED 8-3-2010.
- 3,940,562. **VANILLA SKY (STANDARD CHARACTER).** I'M JDA LLC, (U.S. CLS. 100, 101 AND 102). SN 85-098,788. PUB. 1-18-2011. FILED 8-3-2010.
- 3,940,565. **VERICHANNEL (STANDARD CHARACTER).** VERICHANNEL, LLC, (U.S. CLS. 100, 101 AND 102). SN 85-098,835. PUB. 1-18-2011. FILED 8-3-2010.
- 3,940,568. **FCB ID AUTOMATIC ID/ DATA CAPTURE SOLUTIONS AND DESIGN.** FC BACKGROUND, LLC, DBA FCB ID, (U.S. CLS. 100, 101 AND 102). SN 85-098,856. PUB. 1-18-2011. FILED 8-3-2010.
- 3,940,571. **TOPGRILL (STANDARD CHARACTER).** TOP GRILL IMPORTS, LLC, (U.S. CLS. 100, 101 AND 102). SN 85-098,933. PUB. 1-18-2011. FILED 8-3-2010.
- 3,940,588. **RICKER'S AND DESIGN.** RICKER OIL COMPANY, INC., (U.S. CLS. 100, 101 AND 102). SN 85-099,297. PUB. 1-18-2011. FILED 8-3-2010.
- 3,940,590. **PULSE (STANDARD CHARACTER).** NEUDESIC, LLC, (U.S. CLS. 100, 101 AND 102). SN 85-099,325. PUB. 1-18-2011. FILED 8-3-2010.
- 3,940,591. **NEXTWAVE (STANDARD CHARACTER).** NEXTWAVE, INC., MULTIPLE CLASS, (INT. CLS. 35 AND 36), (U.S. CLS. 100, 101 AND 102). SN 85-099,349. PUB. 1-18-2011. FILED 8-3-2010.
- 3,940,606. **ALLEGIANTRMD (STANDARD CHARACTER).** ALLEGIANTRMD, INC., (U.S. CLS. 100, 101 AND 102). SN 85-099,645. PUB. 1-18-2011. FILED 8-4-2010.
- 3,940,610. **SPACEHELPWANTED.COM AND DESIGN.** BERKSHIRE SERVICES LLC, (U.S. CLS. 100, 101 AND 102). SN 85-099,672. PUB. 1-18-2011. FILED 8-4-2010.
- 3,940,618. **CLUBHOUSE KIDS AND DESIGN.** NICOLE LAUREN LLC, (U.S. CLS. 100, 101 AND 102). SN 85-099,787. PUB. 1-18-2011. FILED 8-4-2010.
- 3,940,622. **GOOD BUSINESS IS GOOD MEDICINE. (STANDARD CHARACTER).** THE CROES OLIVA GROUP, INC., MULTIPLE CLASS, (INT. CLS. 35 AND 44), (U.S. CLS. 100, 101 AND 102). SN 85-099,846. PUB. 1-18-2011. FILED 8-4-2010.
- 3,940,623. **DESTINATION...HEALTH & INNER BALANCE. (STANDARD CHARACTER).** NUTRI-HEALTH SUPPLEMENTS, LLC, (U.S. CLS. 100, 101 AND 102). SN 85-099,864. PUB. 1-18-2011. FILED 8-4-2010.
- 3,940,630 ( *See Class 24 for this trademark.* )
- 3,940,650. **IT'S NOT JUST A CARD, IT'S YOUR BUSINESS (STANDARD CHARACTER).** AUTOTEC, LLC, (U.S. CLS. 100, 101 AND 102). SN 85-100,170. PUB. 1-18-2011. FILED 8-4-2010.
- 3,940,651. **FREQUENCY REWARDS (STANDARD CHARACTER).** THORNTONS INC., (U.S. CLS. 100, 101 AND 102). SN 85-100,174. PUB. 1-18-2011. FILED 8-4-2010.
- 3,940,663. **THE CREPE CRUSADERS AND DESIGN.** KELLER, LINDA, (U.S. CLS. 100, 101 AND 102). SN 85-100,338. PUB. 1-18-2011. FILED 8-4-2010.
- 3,940,664. **EXPERIENCE COLUMBUS AND DESIGN.** GREATER COLUMBUS CONVENTION & VISITOR BUREAU, CORP, (U.S. CLS. 100, 101 AND 102). SN 85-100,364. PUB. 1-18-2011. FILED 8-4-2010.
- 3,940,671. **MOB HOOKS (STANDARD CHARACTER).** GRANIER, BRADY, AND DECSEPEL, DAVID, AND MARKEL, DANIEL, AND NEWLAND, MICHELLE, AND WELCH, THOMAS, (U.S. CLS. 100, 101 AND 102). SN 85-100,458. PUB. 1-18-2011. FILED 8-4-2010.
- 3,940,673. **FOR THE LOVE OF GOOD HEALTH (STANDARD CHARACTER).** THE TASTEFUL OLIVE, LLC, (U.S. CLS. 100, 101 AND 102). SN 85-100,470. PUB. 1-18-2011. FILED 8-4-2010.
- 3,940,676. **PICKY RICKY (STANDARD CHARACTER).** PICKY RICKY, INC., (U.S. CLS. 100, 101 AND 102). SN 85-100,498. PUB. 1-18-2011. FILED 8-4-2010.
- 3,940,691. **WHERE RED CARPET MEETS REDNECK (STANDARD CHARACTER).** BACK PORCH PRODUCTIONS LLC, (U.S. CLS. 100, 101 AND 102). SN 85-100,729. PUB. 1-18-2011. FILED 8-5-2010.
- 3,940,698 ( *See Class 30 for this trademark.* )
- 3,940,707. **ASSET360 (STANDARD CHARACTER).** UNIVERSAL HOSPITAL SERVICES, INC., MULTIPLE CLASS, (INT. CLS. 35, 37 AND 44), (U.S. CLS. 100, 101, 102, 103 AND 106). SN 85-100,911. PUB. 1-18-2011. FILED 8-5-2010.
- 3,940,726. **UHS UNIVERSAL HOSPITAL SERVICES AND DESIGN.** UNIVERSAL HOSPITAL SERVICES, INC., MULTIPLE CLASS, (INT. CLS. 35, 37 AND 44), (U.S. CLS. 100, 101, 102, 103 AND 106). SN 85-101,174. PUB. 1-18-2011. FILED 8-5-2010.
- 3,940,732. **BIDMACS (STANDARD CHARACTER).** THE SHOCK BOX LLC, (U.S. CLS. 100, 101 AND 102). SN 85-101,290. PUB. 1-18-2011. FILED 8-5-2010.
- 3,940,739. **CLUBSCENECRITICS.COM (STANDARD CHARACTER).** CLUBSCENECRITICS.COM LLC, (U.S. CLS. 100, 101 AND 102). SN 85-101,352. PUB. 1-18-2011. FILED 8-5-2010.

3,940,755. **JUST MY TICKET 96653355 AND DESIGN**. METROMOBILE MARKETING, INC., (U.S. CLS. 100, 101 AND 102). SN 85-101,531. PUB. 1-18-2011. FILED 8-5-2010.

3,940,759. **EZ CPAP AND DESIGN**. EZ CPAP, (U.S. CLS. 100, 101 AND 102). SN 85-101,566. PUB. 1-18-2011. FILED 8-5-2010.

3,940,764. **READINESS 360 (STANDARD CHARACTER)**. KILDA GROUP LLC, (U.S. CLS. 100, 101 AND 102). SN 85-101,700. PUB. 1-18-2011. FILED 8-6-2010.

3,940,765. **BEAUTIFUL SKIN. BEAUTIFUL LIFE. (STANDARD CHARACTER)**. BC INTERNATIONAL COSMETIC & IMAGE SERVICES, INC., (U.S. CLS. 100, 101 AND 102). SN 85-101,738. PUB. 1-18-2011. FILED 8-6-2010.

3,940,766. **(( ( OLD ELFS !!!)) AND DESIGN**. GALEN HOVER, (U.S. CLS. 100, 101 AND 102). SN 85-101,775. PUB. 1-18-2011. FILED 8-6-2010.

3,940,776. **RAZBOX (STANDARD CHARACTER)**. DOMINION ENTERPRISES, (U.S. CLS. 100, 101 AND 102). SN 85-101,969. PUB. 1-18-2011. FILED 8-6-2010.

3,940,800. **VACSHACK (STANDARD CHARACTER)**. VACSHACK.COM, INC., (U.S. CLS. 100, 101 AND 102). SN 85-102,315. PUB. 1-18-2011. FILED 8-6-2010.

3,940,801. **QUOTEWIZARD (STANDARD CHARACTER)**. QUOTEWIZARD.COM, LLC, (U.S. CLS. 100, 101 AND 102). SN 85-102,316. PUB. 1-18-2011. FILED 8-6-2010.

3,940,810. **BARNSTORMERS.COM (STANDARD CHARACTER)**. BARNSTORMERS INC, (U.S. CLS. 100, 101 AND 102). SN 85-102,455. PUB. 1-18-2011. FILED 8-6-2010.

3,940,822. **AM2T (STANDARD CHARACTER)**. ADVANCED MATERIALS AND MANUFACTURING TECHNOLOGIES, LLC, MULTIPLE CLASS, (INT. CLS. 35, 40 AND 42), (U.S. CLS. 100, 101, 102, 103 AND 106). SN 85-102,544. PUB. 1-18-2011. FILED 8-7-2010.

3,940,823. **COVERHOUND (STANDARD CHARACTER)**. COVERHOUND, INC., (U.S. CLS. 100, 101 AND 102). SN 85-102,555. PUB. 1-18-2011. FILED 8-7-2010.

3,940,838. **KEGFLY (STANDARD CHARACTER)**. KEGFLY LLC, (U.S. CLS. 100, 101 AND 102). SN 85-103,173. PUB. 1-18-2011. FILED 8-9-2010.

3,940,839. **VALUES BLUEPRINT (STANDARD CHARACTER)**. PEOPLE INK CORPORATION, (U.S. CLS. 100, 101 AND 102). SN 85-103,199. PUB. 1-18-2011. FILED 8-9-2010.

3,940,847. **THE FOUNDARY (STANDARD CHARACTER)**. HAYNEEDLE, INC., (U.S. CLS. 100, 101 AND 102). SN 85-103,444. PUB. 1-18-2011. FILED 8-9-2010.

3,940,862. **MCLUB (STANDARD CHARACTER)**. MIDITAINMENT, INC., (U.S. CLS. 100, 101 AND 102). SN 85-104,542. PUB. 1-18-2011. FILED 8-10-2010.

3,940,865. **CORNER CRAFT SHOP (STANDARD CHARACTER)**. MALDONADO, ALEX, (U.S. CLS. 100, 101 AND 102). SN 85-105,872. PUB. 1-18-2011. FILED 8-12-2010.

3,940,869. **DOMAINMETRIX (STANDARD CHARACTER)**. FAIRWINDS PARTNERS, LLC, MULTIPLE CLASS, (INT. CLS. 35 AND 42), (U.S. CLS. 100, 101 AND 102). SN 85-106,847. PUB. 1-18-2011. FILED 8-13-2010.

3,940,884. **BUILDERLINK (STANDARD CHARACTER)**. BUILDERLINK, LLC, (U.S. CLS. 100, 101 AND 102). SN 85-110,396. PUB. 1-18-2011. FILED 8-18-2010.

3,940,888. **BUILDERLINK CONNECTING THE BUILDING COMMUNITY AND DESIGN**. BUILDERLINK, LLC, (U.S. CLS. 100, 101 AND 102). SN 85-110,644. PUB. 1-18-2011. FILED 8-18-2010.

3,940,902. **NRA-ILA (STANDARD CHARACTER)**. NATIONAL RIFLE ASSOCIATION OF AMERICA, (U.S. CLS. 100, 101 AND 102). SN 85-115,360. PUB. 1-18-2011. FILED 8-25-2010.

3,940,909. **PANOPTIS IP (STANDARD CHARACTER)**. PANOPTIS IP, LLC, MULTIPLE CLASS, (INT. CLS. 35 AND 36), (U.S. CLS. 100, 101 AND 102). SN 85-116,693. PUB. 1-18-2011. FILED 8-26-2010.

3,940,916. **CAMPUSOUP (STANDARD CHARACTER)**. KEGFLY LLC, (U.S. CLS. 100, 101 AND 102). SN 85-118,405. PUB. 1-18-2011. FILED 8-30-2010.

3,940,921. **SILVER DOLLAR OPTICAL (STANDARD CHARACTER)**. SILVER DOLLAR OPTICAL CORPORATION, (U.S. CLS. 100, 101 AND 102). SN 85-120,712. PUB. 1-18-2011. FILED 9-1-2010.

3,940,924. **A AND DESIGN**. ALLSCRIPTS, LLC, MULTIPLE CLASS, (INT. CLS. 35 AND 42), (U.S. CLS. 100, 101 AND

102). SN 85-121,381. PUB. 1-18-2011. FILED 9-2-2010.

3,940,927. **USPDF (STANDARD CHARACTER)**. USPDF, LLC, MULTIPLE CLASS, (INT. CLS. 35 AND 41), (U.S. CLS. 100, 101, 102 AND 107). SN 85-123,535. PUB. 1-18-2011. FILED 9-6-2010.

3,940,932. **MANIC PANIC (STYLIZED)**. TISH & SNOOKY'S N.Y.C. INC., (U.S. CLS. 100, 101 AND 102). SN 85-127,593. PUB. 1-18-2011. FILED 9-11-2010.

3,940,947. **FITNESS FOR UNCERTAINTY (STANDARD CHARACTER)**. PRICEWATERHOUSECOOPERS LLP, (U.S. CLS. 100, 101 AND 102). SN 85-132,370. PUB. 1-18-2011. FILED 9-17-2010.

3,940,958. **BECAUSE GREEN IS GOOD BUSINESS (STANDARD CHARACTER)**. DELAWARE CAPITAL FORMATION, INC., (U.S. CLS. 100, 101 AND 102). SN 85-142,001. PUB. 1-18-2011. FILED 9-30-2010.

3,940,970. **PULSE AND DESIGN**. NEUDESIC, LLC, (U.S. CLS. 100, 101 AND 102). SN 85-159,470. PUB. 1-18-2011. FILED 10-22-2010.

---

### CLASS 36—INSURANCE AND FINANCIAL

3,939,392. **SCOREMAX (STANDARD CHARACTER)**. FRED MARTIN MOTOR COMPANY, (U.S. CLS. 100, 101 AND 102). SN 77-062,157. PUB. 1-18-2011. FILED 12-12-2006.

3,939,394 ( *See Class 16 for this trademark*).

3,939,416. **TSX QUANTUMFEED (STANDARD CHARACTER)**. TSX INC., (U.S. CLS. 100, 101 AND 102). SN 77-417,246. PUB. 1-18-2011. FILED 3-10-2008.

3,939,431 ( *See Class 35 for this trademark*).

3,939,432 ( *See Class 35 for this trademark*).

3,939,448 ( *See Class 35 for this trademark*).

3,939,459. **DESIGN IT! PHOTOCARD (STANDARD CHARACTER)**. FIFTH THIRD PROCESSING SOLUTIONS, LLC, (U.S. CLS. 100, 101 AND 102). SN 77-688,276. PUB. 1-18-2011. FILED 3-11-2009.

3,939,497. **APPEALS BOARD REPORTER (STANDARD CHARACTER)**. PROVIDENCE PUBLICATIONS, LLC, MULTIPLE CLASS, (INT. CLS. 36, 41, 44 AND 45), (U.S. CLS. 100, 101, 102 AND 107). SN 77-777,920. PUB. 1-18-2011. FILED 7-9-2009.

3,939,498. **WORKERS' COMP EXECUTIVE (STANDARD CHARACTER)**. PROVIDENCE PUBLICATIONS, LLC, MULTIPLE CLASS, (INT. CLS. 36, 38, 41, 44 AND 45), (U.S. CLS. 100, 101, 102, 104 AND 107). SN 77-777,923. PUB. 1-18-2011. FILED 7-9-2009.

3,939,513. **PMA FUNDING (STANDARD CHARACTER)**. PRUDENT MAN ANALYSIS, INC., (U.S. CLS. 100, 101 AND 102). SN 77-792,584. PUB. 1-18-2011. FILED 7-29-2009.

3,939,528. **ORTHO BANC AND DESIGN**. ORTHOBANC, LLC, (U.S. CLS. 100, 101 AND 102). SN 77-808,875. PUB. 1-18-2011. FILED 8-20-2009.

3,939,537. **ENTRUST FEDERAL CREDIT UNION AND DESIGN**. ENTRUST FEDERAL CREDIT UNION, (U.S. CLS. 100, 101 AND 102). SN 77-813,891. PUB. 1-18-2011. FILED 8-27-2009.

3,939,551. **WALL STREET RAW (STANDARD CHARACTER)**. ZACHARY EDWARD LEIBOVIT CHILDREN'S TRUST, (U.S. CLS. 100, 101 AND 102). SN 77-837,626. PUB. 1-18-2011. FILED 9-29-2009.

3,939,579. **SEDO (STANDARD CHARACTER)**. SEDO.COM, LLC, (U.S. CLS. 100, 101 AND 102). SN 77-868,116. PUB. 10-12-2010. FILED 11-9-2009.

3,939,592. **COMMISSION-SAFE (STANDARD CHARACTER)**. SALLEN, STEVEN D., (U.S. CLS. 100, 101 AND 102). SN 77-881,992. PUB. 1-18-2011. FILED 11-30-2009.

3,939,606. **SALESIAN MISSIONS AND DESIGN**. SALESIAN MISSIONS, MULTIPLE CLASS, (INT. CLS. 36, 41, 43 AND 45), (U.S. CLS. 100, 101, 102 AND 107). SN 77-895,538. PUB. 1-18-2011. FILED 12-17-2009.

3,939,618. **MGIVE (STANDARD CHARACTER)**. MOBILE ACCORD, INC., (U.S. CLS. 100, 101 AND 102). SN 77-904,501. PUB. 1-18-2011. FILED 1-4-2010.

3,939,637. **THE CLOSING NAVIGATOR (STANDARD CHARACTER)**. TRI-OAK COMMERCIAL GROUP, INC., (U.S. CLS. 100, 101 AND 102). SN 77-917,555. PUB. 8-24-2010.

- FILED 1-22-2010.  
 3,939,654 ( *See Class 35 for this trademark* ).  
 3,939,657. **COMPLIANCE FIREWALL (STANDARD CHARACTER)**. FINESTONE PARTNERS, (U.S. CLS. 100, 101 AND 102). SN 77-923,005. PUB. 1-18-2011. FILED 1-28-2010.  
 3,939,672. **S SSG CAPITAL ADVISORS, LLC AND DESIGN**. SSG CAPITAL ADVISORS, LLC, (U.S. CLS. 100, 101 AND 102). SN 77-926,049. PUB. 1-18-2011. FILED 2-2-2010.  
 3,939,675. **MERCHANT SERVICES CLUB AND DESIGN**. COUNTRYWIDE VENDING, INC., (U.S. CLS. 100, 101 AND 102). SN 77-928,211. PUB. 1-18-2011. FILED 2-4-2010.  
 3,939,690. **SR SIGNATURE REAL ESTATE AND DESIGN**. SIGNATURE REAL ESTATE, LLC, (U.S. CLS. 100, 101 AND 102). SN 77-930,249. PUB. 1-18-2011. FILED 2-8-2010.  
 3,939,714. **OPENSTREET AND DESIGN**. OPENSTREET USA INCORPORATED, AND OPENSTREET CANADA INCORPORATED, (U.S. CLS. 100, 101 AND 102). SN 77-935,382. PUB. 1-18-2011. FILED 2-13-2010.  
 3,939,717. **Q CERTIFIED (STYLIZED)**, THE WARRANTY GROUP, INC., (U.S. CLS. 100, 101 AND 102). SN 77-935,726. PUB. 1-18-2011. FILED 2-15-2010.  
 3,939,721. **ACTODAY (STANDARD CHARACTER)**. ACTODAY FOUNDATION, INC., (U.S. CLS. 100, 101 AND 102). SN 77-936,164. PUB. 1-18-2011. FILED 2-16-2010.  
 3,939,730 ( *See Class 16 for this trademark* ).  
 3,939,743. **MISCELLANEOUS DESIGN**. GREEN MOUNTAIN COMMUNICATIONS, INC., MULTIPLE CLASS, (INT. CLS. 36, 37 AND 42), (U.S. CLS. 100, 101, 102, 103 AND 106). SN 77-938,857. PUB. 1-18-2011. FILED 2-18-2010.  
 3,939,816. **GOREC (STANDARD CHARACTER)**. GLOBEOP FINANCIAL SERVICES, LLC, MULTIPLE CLASS, (INT. CLS. 36 AND 42), (U.S. CLS. 100, 101 AND 102). SN 77-958,853. PUB. 1-18-2011. FILED 3-15-2010.  
 3,939,825 ( *See Class 35 for this trademark* ).  
 3,939,826 ( *See Class 35 for this trademark* ).  
 3,939,832. **CREATING VISIBILITY TO THE FINANCIAL CHOICES THAT AFFECT YOUR LIFE. (STANDARD CHARACTER)**. HAMEL, SCOTT W, (U.S. CLS. 100, 101 AND 102). SN 77-963,021. PUB. 1-18-2011. FILED 3-19-2010.  
 3,939,839. **VISUAL DIARIES (STANDARD CHARACTER)**. THE CREATIVE CENTER, INC., MULTIPLE CLASS, (INT. CLS. 36 AND 41), (U.S. CLS. 100, 101, 102 AND 107). SN 77-964,874. PUB. 1-18-2011. FILED 3-22-2010.  
 3,939,851. **TOM STRIGNANO FOREX (STANDARD CHARACTER)**. STRIGNANO FOREX, (U.S. CLS. 100, 101 AND 102). SN 77-966,249. PUB. 1-18-2011. FILED 3-23-2010.  
 3,939,891 ( *See Class 35 for this trademark* ).  
 3,939,899 ( *See Class 9 for this trademark* ).  
 3,939,901 ( *See Class 35 for this trademark* ).  
 3,939,904 ( *See Class 9 for this trademark* ).  
 3,939,915 ( *See Class 35 for this trademark* ).  
 3,939,923. **BUDGETAIR AND DESIGN**. BCD HOLDINGS N.V., MULTIPLE CLASS, (INT. CLS. 36, 39 AND 43), (U.S. CLS. 100, 101, 102 AND 105). SN 79-076,281. PUB. 1-18-2011. FILED 7-24-2009.  
 3,939,931 ( *See Class 14 for this trademark* ).  
 3,939,939 ( *See Class 9 for this trademark* ).  
 3,939,967 ( *See Class 25 for this trademark* ).  
 3,939,971 ( *See Class 9 for this trademark* ).  
 3,940,020. **ALTEVIA FINANCE (STANDARD CHARACTER)**. ALTEA FINANCIAL SERVICES GMBH, (U.S. CLS. 100, 101 AND 102). SN 79-083,085. PUB. 1-18-2011. FILED 4-1-2010.  
 3,940,148 ( *See Class 9 for this trademark* ).  
 3,940,161 ( *See Class 35 for this trademark* ).  
 3,940,164. **U-SCOOT AMERICA'S CHOICE FOR POWER MOBILITY AND DESIGN**. MRB ACQUISITION CORP., DBA U-SCOOT, (U.S. CLS. 100, 101 AND 102). SN 85-038,993. PUB. 1-18-2011. FILED 5-14-2010.  
 3,940,165. **OPEN-AIRE THE PORTABLE OXYGEN EXPERTS AND DESIGN**. MRB ACQUISITION CORP., DBA OPEN-AIRE, (U.S. CLS. 100, 101 AND 102). SN 85-039,028. PUB. 1-18-2011. FILED 5-14-2010.  
 3,940,171. **ADOBE (STANDARD CHARACTER)**. ADOBE SYSTEMS INCORPORATED, (U.S. CLS. 100, 101 AND 102). SN 85-040,224. PUB. 1-18-2011. FILED 5-17-2010.  
 3,940,172. **ADOBE FINANCIAL SERVICES (STANDARD CHARACTER)**. ADOBE SYSTEMS INCORPORATED, (U.S. CLS. 100, 101 AND 102). SN 85-040,244. PUB. 1-18-2011. FILED 5-17-2010.  
 3,940,173. **EASEL CREATE YOUR FINANCIAL MASTERPIECE AND DESIGN**. EASEL, (U.S. CLS. 100, 101 AND 102). SN 85-040,480. PUB. 10-19-2010. FILED 5-17-2010.  
 3,940,214 ( *See Class 35 for this trademark* ).  
 3,940,217. **COHEN ASSET MANAGEMENT (STANDARD CHARACTER)**. COHEN ASSET MANAGEMENT, INC., (U.S. CLS. 100, 101 AND 102). SN 85-055,205. PUB. 1-18-2011. FILED 6-4-2010.  
 3,940,227. **TRADE DOCK AND DESIGN**. TRADE DOCK CO., (U.S. CLS. 100, 101 AND 102). SN 85-057,512. PUB. 1-18-2011. FILED 6-8-2010.  
 3,940,233 ( *See Class 9 for this trademark* ).  
 3,940,242. **TRAFFIC JAM (STANDARD CHARACTER)**. ORPHAN LIFELINE, (U.S. CLS. 100, 101 AND 102). SN 85-062,077. PUB. 1-18-2011. FILED 6-14-2010.  
 3,940,258. **CARS FOR WISHES AND DESIGN**. CAR DONATION FOUNDATION, (U.S. CLS. 100, 101 AND 102). SN 85-065,764. PUB. 1-18-2011. FILED 6-17-2010.  
 3,940,272. **CITA INSURANCE SERVICES AND DESIGN**. BROWN & BROWN OF CALIFORNIA, INC., (U.S. CLS. 100, 101 AND 102). SN 85-069,839. PUB. 1-18-2011. FILED 6-23-2010.  
 3,940,306. **CUSTOMER SERVICE = RESOLUTION (STANDARD CHARACTER)**. SAFEGUARD PROPERTIES, LLC, (U.S. CLS. 100, 101 AND 102). SN 85-080,437. PUB. 1-18-2011. FILED 7-8-2010.  
 3,940,307. **EVEN KEEL MARITIME SOLUTIONS AND DESIGN**. BROWN & BROWN OF WASHINGTON, INC., (U.S. CLS. 100, 101 AND 102). SN 85-080,548. PUB. 1-18-2011. FILED 7-8-2010.  
 3,940,316. **CREATING EASE WITH WEALTH (STANDARD CHARACTER)**. CANNON & ASSOCIATES FINANCIAL AND BUSINESS SOLUTIONS, LLC, DBA CANNON WEALTH MANAGEMENT, (U.S. CLS. 100, 101 AND 102). SN 85-081,856. PUB. 1-18-2011. FILED 7-9-2010.  
 3,940,373 ( *See Class 35 for this trademark* ).  
 3,940,374 ( *See Class 35 for this trademark* ).  
 3,940,399. **AGENTOFFICE (STANDARD CHARACTER)**. EMPHASYS COMPUTER SOLUTIONS, INC., MULTIPLE CLASS, (INT. CLS. 36 AND 42), (U.S. CLS. 100, 101 AND 102). SN 85-094,190. PUB. 1-18-2011. FILED 7-27-2010.  
 3,940,467. **W (STYLIZED)**. WESTOVER CAPITAL ADVISORS, LLC, (U.S. CLS. 100, 101 AND 102). SN 85-097,382. PUB. 1-18-2011. FILED 7-30-2010.  
 3,940,468. **GIVELOCALLY (STANDARD CHARACTER)**. GIVELOCALLY LLC, (U.S. CLS. 100, 101 AND 102). SN 85-097,395. PUB. 1-18-2011. FILED 7-30-2010.  
 3,940,470. **LOCAL GIVING MADE EASY (STANDARD CHARACTER)**. GIVELOCALLY LLC, (U.S. CLS. 100, 101 AND 102). SN 85-097,408. PUB. 1-18-2011. FILED 7-30-2010.  
 3,940,500. **MOVING CLEAN ENERGY FORWARD. (STANDARD CHARACTER)**. NRG ENERGY, INC., (U.S. CLS. 100, 101 AND 102). SN 85-097,747. PUB. 1-18-2011. FILED 8-2-2010.  
 3,940,531. **TRANSITION MADE SIMPLE (STANDARD CHARACTER)**. PHYSICIANS MUTUAL INSURANCE COMPANY, MULTIPLE CLASS, (INT. CLS. 36 AND 41), (U.S. CLS. 100, 101, 102 AND 107). SN 85-098,352. PUB. 1-18-2011. FILED 8-2-2010.  
 3,940,535. **BBVA COMPASS AND DESIGN**. COMPASS BANKSHARES, INC., (U.S. CLS. 100, 101 AND 102). SN 85-098,390. PUB. 1-18-2011. FILED 8-2-2010.  
 3,940,538. **GIVE BACK CARD AND DESIGN**. 10 PERCENT SOLUTION, INC., (U.S. CLS. 100, 101 AND 102). SN 85-098,433. PUB. 1-18-2011. FILED 8-2-2010.  
 3,940,561. **CAPITAL EXPERTISE EXECUTION AND DESIGN**. BRANCH PROPERTIES, LLC, MULTIPLE CLASS, (INT. CLS. 36 AND 37), (U.S. CLS. 100, 101, 102, 103 AND 106). SN 85-098,765. PUB. 1-18-2011. FILED 8-3-2010.  
 3,940,587. **GEONOVA (STANDARD CHARACTER)**. GEONOVA HOLDINGS, LTD. LLC, (U.S. CLS. 100, 101 AND 102). SN 85-099,285. PUB. 1-18-2011. FILED 8-3-2010.  
 3,940,591 ( *See Class 35 for this trademark* ).  
 3,940,603. **MISCELLANEOUS DESIGN**. ATLANTA HISTORICAL SOCIETY, INC., DBA ATLANTA HISTORY CENTER, (U.S. CLS. 100, 101 AND 102). SN 85-099,568. PUB. 1-18-2011. FILED 8-4-2010.



3,940,615. **CUSTOM SELECT REALTY SELECT . SAVE . SELL AND DESIGN.** CUSTOM SELECT REALTY, LLC, (U.S. CLS. 100, 101 AND 102). SN 85-099,769. PUB. 1-18-2011. FILED 8-4-2010.

3,940,636. **A R AND DESIGN.** ALDASORO RANCH HOMEOWNERS COMPANY, AKA ALDASORO RANCH, (U.S. CLS. 100, 101 AND 102). SN 85-100,017. PUB. 1-18-2011. FILED 8-4-2010.

3,940,646. **MODA UPGRADED LIVING (STANDARD CHARACTER).** QFC ASSOCIATES, LLC, MULTIPLE CLASS, (INT. CLS. 36, 37 AND 45), (U.S. CLS. 100, 101, 102, 103 AND 106). SN 85-100,145. PUB. 1-18-2011. FILED 8-4-2010.

3,940,652. **MODA UPGRADED LIVING AND DESIGN.** QFC ASSOCIATES, LLC, MULTIPLE CLASS, (INT. CLS. 36, 37 AND 45), (U.S. CLS. 100, 101, 102, 103 AND 106). SN 85-100,177. PUB. 1-18-2011. FILED 8-4-2010.

3,940,659. **MISCELLANEOUS DESIGN.** ANCHORAGE CAPITAL MANAGEMENT, L.L.C., (U.S. CLS. 100, 101 AND 102). SN 85-100,287. PUB. 1-18-2011. FILED 8-4-2010.

3,940,689. **IMPACTONDEMAND (STANDARD CHARACTER).** AON BENFIELD GLOBAL, INC., (U.S. CLS. 100, 101 AND 102). SN 85-100,668. PUB. 1-18-2011. FILED 8-5-2010.

3,940,693. **INSURING TODAY'S TREASURES FROM TOMORROW'S TRAGEDY (STANDARD CHARACTER).** GLOBAL INDEMNITY GROUP, INC., (U.S. CLS. 100, 101 AND 102). SN 85-100,764. PUB. 1-18-2011. FILED 8-5-2010.

3,940,730. **1ST RESPONSE PUBLIC ADJUSTERS, INC. (STANDARD CHARACTER).** 1ST RESPONSE PUBLIC ADJUSTERS, INC., (U.S. CLS. 100, 101 AND 102). SN 85-101,266. PUB. 1-18-2011. FILED 8-5-2010.

3,940,782. **YOU'RE A NEIGHBOR, NOT A NUMBER. (STANDARD CHARACTER).** VILLAGE BANK AND TRUST FINANCIAL CORPORATION, (U.S. CLS. 100, 101 AND 102). SN 85-102,018. PUB. 1-18-2011. FILED 8-6-2010.

3,940,793. **YORKVILLE ADVISORS (STANDARD CHARACTER).** YORKVILLE ADVISORS, LLC, (U.S. CLS. 100, 101 AND 102). SN 85-102,216. PUB. 1-18-2011. FILED 8-6-2010.

3,940,820. **EMERINT (STANDARD CHARACTER).** EMERGING MARKETS INTERNATIONAL GROUP LLC, DBA EMERINT, (U.S. CLS. 100, 101 AND 102). SN 85-102,539. PUB. 1-18-2011. FILED 8-7-2010.

3,940,874. **YIELD PLEDGE (STANDARD CHARACTER).** EVERBANK, (U.S. CLS. 100, 101 AND 102). SN 85-108,585. PUB. 1-18-2011. FILED 8-16-2010.

3,940,875. **I BOOBIES! AND DESIGN.** THE KEEP A BREAST FOUNDATION, (U.S. CLS. 100, 101 AND 102). SN 85-108,717. PUB. 1-18-2011. FILED 8-16-2010.

3,940,886. **COLLEGE ROCKET AND DESIGN.** ONESHARE INVESTMENTS, LLC, DBA COLLEGE ROCKET, (U.S. CLS. 100, 101 AND 102). SN 85-110,571. PUB. 1-18-2011. FILED 8-18-2010.

3,940,887. **STRUCTURED SETTLEMENT AUTHORITY (STYLIZED).** J.G. WENTWORTH S.S.C. LIMITED PARTNERSHIP, (U.S. CLS. 100, 101 AND 102). SN 85-110,587. PUB. 1-18-2011. FILED 8-18-2010.

3,940,897. **ELEVATE REAL ESTATE (STANDARD CHARACTER).** ELEVATE REAL ESTATE, INC., MULTIPLE CLASS, (INT. CLS. 36 AND 37), (U.S. CLS. 100, 101, 102, 103 AND 106). SN 85-112,722. PUB. 1-18-2011. FILED 8-20-2010.

3,940,903. **STAG CAPITAL PARTNERS (STANDARD CHARACTER).** STAG CAPITAL PARTNERS, LLC, (U.S. CLS. 100, 101 AND 102). SN 85-115,635. PUB. 1-18-2011. FILED 8-25-2010.

3,940,908. **IFET IRREVOCABLE FUNERAL EXPENSE TRUST (STANDARD CHARACTER).** HARBOR FINANCIAL GROUP, INC, (U.S. CLS. 100, 101 AND 102). SN 85-116,663. PUB. 1-18-2011. FILED 8-26-2010.

3,940,909 ( *See Class 35 for this trademark.*).

3,940,912. **ICD (STANDARD CHARACTER).** CREDIT SUISSE SECURITIES (USA) LLC, (U.S. CLS. 100, 101 AND 102). SN 85-117,309. PUB. 1-18-2011. FILED 8-27-2010.

3,940,913. **SOUTHBRIDGE MALL (STANDARD CHARACTER).** THE MILLS LIMITED PARTNERSHIP, (U.S. CLS. 100, 101 AND 102). SN 85-117,867. PUB. 1-18-2011. FILED 8-27-2010.

3,940,917. **K2 (STANDARD CHARACTER).** K2 ADVISORS L.L.C., (U.S. CLS. 100, 101 AND 102). SN 85-118,958. PUB. 1-18-2011. FILED 8-30-2010.

3,940,918. **EVERBANK (STANDARD CHARACTER).** EVER-

BANK, (U.S. CLS. 100, 101 AND 102). SN 85-119,405. PUB. 1-18-2011. FILED 8-31-2010.

3,940,954. **PATRIOTIC PRIVATE MONEY (STANDARD CHARACTER).** SUPPORT OUR TROOPS FOUNDATION, INC., (U.S. CLS. 100, 101 AND 102). SN 85-138,360. PUB. 1-18-2011. FILED 9-26-2010.

3,940,961. **1 AND DESIGN.** ROUTE ONE INVESTMENT COMPANY, L.P., (U.S. CLS. 100, 101 AND 102). SN 85-145,275. PUB. 1-18-2011. FILED 10-5-2010.

3,940,971. **PNC REVERSE MORTGAGE LLC (STANDARD CHARACTER).** THE PNC FINANCIAL SERVICES GROUP, INC., (U.S. CLS. 100, 101 AND 102). SN 85-160,965. PUB. 1-18-2011. FILED 10-26-2010.

---

## CLASS 37—CONSTRUCTION AND REPAIR

3,939,350. **SMART CITY (STANDARD CHARACTER).** SMART CITY HOLDINGS, L.L.C., MULTIPLE CLASS, (INT. CLS. 37, 38 AND 42), (U.S. CLS. 100, 101, 103, 104 AND 106). SN 76-626,824. PUB. 1-18-2011. FILED 1-4-2005.

3,939,448 ( *See Class 35 for this trademark.*).

3,939,477. **PROJECT GREEN (STYLIZED).** J. S. VIG CONSTRUCTION CO., (U.S. CLS. 100, 103 AND 106). SN 77-733,184. PUB. 1-18-2011. FILED 5-9-2009.

3,939,478. **PROJECT GREEN TEAM (STANDARD CHARACTER).** J. S. VIG CONSTRUCTION CO., (U.S. CLS. 100, 103 AND 106). SN 77-733,192. PUB. 1-18-2011. FILED 5-9-2009.

3,939,479. **PROJECT GREEN (STANDARD CHARACTER).** J. S. VIG CONSTRUCTION CO., (U.S. CLS. 100, 103 AND 106). SN 77-733,196. PUB. 1-18-2011. FILED 5-9-2009.

3,939,490 ( *See Class 6 for this trademark.*).

3,939,516 ( *See Class 9 for this trademark.*).

3,939,532 ( *See Class 1 for this trademark.*).

3,939,564 ( *See Class 11 for this trademark.*).

3,939,570. **DON'T DRIVE NAKED! (STANDARD CHARACTER).** DREAM STREET GRAPHIC, INC., MULTIPLE CLASS, (INT. CLS. 37 AND 42), (U.S. CLS. 100, 101, 103 AND 106). SN 77-861,651. PUB. 1-18-2011. FILED 10-30-2009.

3,939,571. **DREAM STREET GRAPHICS (STANDARD CHARACTER).** DREAM STREET GRAPHIC, INC., MULTIPLE CLASS, (INT. CLS. 37 AND 42), (U.S. CLS. 100, 101, 103 AND 106). SN 77-861,679. PUB. 1-18-2011. FILED 10-30-2009.

3,939,576. **SCHOEPP MOTORS (STANDARD CHARACTER).** SCHOEPP MOTORS, INC., (U.S. CLS. 100, 103 AND 106). SN 77-864,109. PUB. 1-18-2011. FILED 11-3-2009.

3,939,577. **CONDITIONED AIR THE COMFORT PEOPLE SINCE 1962 AIR CONDITIONING HEATING REFRIGERATION AND DESIGN.** CONDITIONED AIR CORPORATION OF NAPLES, INC., (U.S. CLS. 100, 103 AND 106). SN 77-866,553. PUB. 1-18-2011. FILED 11-6-2009.

3,939,661 ( *See Class 20 for this trademark.*).

3,939,662 ( *See Class 35 for this trademark.*).

3,939,663 ( *See Class 35 for this trademark.*).

3,939,743 ( *See Class 36 for this trademark.*).

3,939,782 ( *See Class 6 for this trademark.*).

3,939,788. **LCS COMMERCIAL (STANDARD CHARACTER).** LILLY'S CLEANING SERVICE, INC, DBA LCS COMMERCIAL, (U.S. CLS. 100, 103 AND 106). SN 77-950,359. PUB. 1-18-2011. FILED 3-4-2010.

3,939,806. **JBR AND DESIGN.** JBR ENVIRONMENTAL CONSULTANTS, INC., MULTIPLE CLASS, (INT. CLS. 37 AND 40), (U.S. CLS. 100, 103 AND 106). SN 77-955,934. PUB. 1-18-2011. FILED 3-10-2010.

3,939,810. **SOUND ENVIRONMENTAL STRATEGIES (STANDARD CHARACTER).** SOUNDEARTH STRATEGIES, INC., MULTIPLE CLASS, (INT. CLS. 37, 40, 42 AND 45), (U.S. CLS. 100, 101, 103 AND 106). SN 77-956,799. PUB. 1-18-2011. FILED 3-11-2010.

3,939,897 ( *See Class 27 for this trademark.*).

3,939,902 ( *See Class 35 for this trademark.*).

3,939,939 ( *See Class 9 for this trademark.*).

3,939,940 ( *See Class 9 for this trademark.*).

3,939,967 ( *See Class 25 for this trademark.*).

3,939,971 ( *See Class 9 for this trademark.*).

3,939,981 ( *See Class 1 for this trademark.*).

3,939,999 ( *See Class 6 for this trademark.*).

- 3,940,011 ( *See Class 7 for this trademark* ).  
 3,940,033 ( *See Class 5 for this trademark* ).  
 3,940,054 ( *See Class 11 for this trademark* ).  
 3,940,154. **GEX (STANDARD CHARACTER)**. NETWORK LEARNING INSTITUTE, INC., DBA GEXX COMPUTER SERVICES, MULTIPLE CLASS, (INT. CLS. 37 AND 42), (U.S. CLS. 100, 101, 103 AND 106). SN 85-034,096. PUB. 10-12-2010. FILED 5-10-2010.  
 3,940,174. **NUTECH NATIONAL (STANDARD CHARACTER)**. NUTECH FIRE & SECURITY, MULTIPLE CLASS, (INT. CLS. 37, 42 AND 45), (U.S. CLS. 100, 101, 103 AND 106). SN 85-040,596. PUB. 1-18-2011. FILED 5-17-2010.  
 3,940,229. **NRG AND DESIGN**. NRG ENERGY, INC., MULTIPLE CLASS, (INT. CLS. 37 AND 40), (U.S. CLS. 100, 103 AND 106). SN 85-058,016. PUB. 1-18-2011. FILED 6-9-2010.  
 3,940,234 ( *See Class 35 for this trademark* ).  
 3,940,257. **PEST LABORATORIES (STANDARD CHARACTER)**. PEST LABORATORIES, LLC, DBA PEST LABORATORIES, (U.S. CLS. 100, 103 AND 106). SN 85-065,507. PUB. 1-18-2011. FILED 6-17-2010.  
 3,940,273. **PLUMB RIGHT SERVICES (STANDARD CHARACTER)**. PLUMB RIGHT SERVICES, (U.S. CLS. 100, 103 AND 106). SN 85-070,417. PUB. 1-18-2011. FILED 6-24-2010.  
 3,940,289. **SEVERE CYCLES (STYLIZED)**. LEWIS, MICHAEL A., (U.S. CLS. 100, 103 AND 106). SN 85-075,089. PUB. 1-18-2011. FILED 6-30-2010.  
 3,940,318 ( *See Class 9 for this trademark* ).  
 3,940,363. **MISCELLANEOUS DESIGN**. CITY OF RAMSEY, (U.S. CLS. 100, 103 AND 106). SN 85-090,181. PUB. 1-18-2011. FILED 7-22-2010.  
 3,940,386. **GREEN. BEAUTIFUL. FOREVER. (STANDARD CHARACTER)**. WATERFORD HOME BUILDERS, LLC, (U.S. CLS. 100, 103 AND 106). SN 85-093,399. PUB. 1-18-2011. FILED 7-27-2010.  
 3,940,425 ( *See Class 9 for this trademark* ).  
 3,940,433. **BAMA CUSTOM TUNING (STANDARD CHARACTER)**. TURN 5, INC., (U.S. CLS. 100, 103 AND 106). SN 85-096,472. PUB. 1-18-2011. FILED 7-30-2010.  
 3,940,511. **PATRIOT ENVIRONMENTAL SERVICES AND DESIGN**. PATRIOT ENVIRONMENTAL SERVICES, (U.S. CLS. 100, 103 AND 106). SN 85-097,942. PUB. 1-18-2011. FILED 8-2-2010.  
 3,940,533. **SKYPALACE AND DESIGN**. SKYLINE EQUITIES REALTY, LLC, (U.S. CLS. 100, 103 AND 106). SN 85-098,380. PUB. 1-18-2011. FILED 8-2-2010.  
 3,940,561 ( *See Class 36 for this trademark* ).  
 3,940,626. **E3 COMMITMENT EXCELLENT SERVICE . EVERY CUSTOMER EVERY TIME AND DESIGN**. E3 ROOFING, LLC, (U.S. CLS. 100, 103 AND 106). SN 85-099,923. PUB. 1-18-2011. FILED 8-4-2010.  
 3,940,646 ( *See Class 36 for this trademark* ).  
 3,940,652 ( *See Class 36 for this trademark* ).  
 3,940,707 ( *See Class 35 for this trademark* ).  
 3,940,726 ( *See Class 35 for this trademark* ).  
 3,940,805. **360SOLAR (STANDARD CHARACTER)**. NEW SYMRNA WORKSHOP, INC., (U.S. CLS. 100, 103 AND 106). SN 85-102,416. PUB. 1-18-2011. FILED 8-6-2010.  
 3,940,871. **MISCELLANEOUS DESIGN**. REMEDY ROOFING, INC., (U.S. CLS. 100, 103 AND 106). SN 85-107,853. PUB. 1-18-2011. FILED 8-15-2010.  
 3,940,891. **FIVE STAR HOLIDAY DECOR (STANDARD CHARACTER)**. FIVE STAR HOLIDAY DECOR INC., (U.S. CLS. 100, 103 AND 106). SN 85-111,780. PUB. 1-18-2011. FILED 8-19-2010.  
 3,940,897 ( *See Class 36 for this trademark* ).
- CLASS, (INT. CLS. 38 AND 41), (U.S. CLS. 100, 101, 104 AND 107). SN 77-767,082. PUB. 1-18-2011. FILED 6-24-2009.  
 3,939,498 ( *See Class 36 for this trademark* ).  
 3,939,502 ( *See Class 9 for this trademark* ).  
 3,939,506 ( *See Class 9 for this trademark* ).  
 3,939,524. **HEARSAY WITH CATHY LEWIS (STANDARD CHARACTER)**. HAMPTON ROADS EDUCATIONAL TELECOMMUNICATIONS ASSOCIATION, INC., DBA WHRO, (U.S. CLS. 100, 101 AND 104). SN 77-799,750. PUB. 11-16-2010. FILED 8-7-2009.  
 3,939,543 ( *See Class 9 for this trademark* ).  
 3,939,624. **MARIE CLAIRE (STANDARD CHARACTER)**. MARIE CLAIRE ALBUM, (U.S. CLS. 100, 101 AND 104). SN 77-912,398. PUB. 1-18-2011. FILED 1-14-2010.  
 3,939,693 ( *See Class 35 for this trademark* ).  
 3,939,707. **MTV (STYLIZED)**. VIACOM INTERNATIONAL INC., (U.S. CLS. 100, 101 AND 104). SN 77-933,802. PUB. 1-18-2011. FILED 2-11-2010.  
 3,939,730 ( *See Class 16 for this trademark* ).  
 3,939,792. **MINDVOX (STANDARD CHARACTER)**. MINDVOX CORPORATION, (U.S. CLS. 100, 101 AND 104). SN 77-951,281. PUB. 1-18-2011. FILED 3-5-2010.  
 3,939,801. **LINKAMERICA (STANDARD CHARACTER)**. COSTQUEST ASSOCIATES, INC., MULTIPLE CLASS, (INT. CLS. 38 AND 42), (U.S. CLS. 100, 101 AND 104). SN 77-953,956. PUB. 1-18-2011. FILED 3-9-2010.  
 3,939,831. **HEALTHY, ENLIGHTENED, ACCOUNTABLE, TEACHERS (STANDARD CHARACTER)**. GREEN, STEPHEN, AND JUNNE, EUNICE, AND RY, PHALLY, AND SOTO, AMALIA, MULTIPLE CLASS, (INT. CLS. 38 AND 41), (U.S. CLS. 100, 101, 104 AND 107). SN 77-962,795. PUB. 1-18-2011. FILED 3-18-2010.  
 3,939,862. **TDN (STANDARD CHARACTER)**. TELEVISA S.A. DE C. V., (U.S. CLS. 100, 101 AND 104). SN 77-981,093. PUB. 5-18-2010. FILED 6-8-2009.  
 3,939,890 ( *See Class 9 for this trademark* ).  
 3,939,899 ( *See Class 9 for this trademark* ).  
 3,939,909 ( *See Class 9 for this trademark* ).  
 3,939,912 ( *See Class 7 for this trademark* ).  
 3,939,913 ( *See Class 3 for this trademark* ).  
 3,939,920 ( *See Class 9 for this trademark* ).  
 3,939,921 ( *See Class 9 for this trademark* ).  
 3,939,939 ( *See Class 9 for this trademark* ).  
 3,939,964 ( *See Class 35 for this trademark* ).  
 3,939,971 ( *See Class 9 for this trademark* ).  
 3,939,973 ( *See Class 35 for this trademark* ).  
 3,940,043. **QUANTHOUSE (STYLIZED)**. QUANT HOUSE SAS, MULTIPLE CLASS, (INT. CLS. 38 AND 42), (U.S. CLS. 100, 101 AND 104). SN 79-085,033. PUB. 1-18-2011. FILED 5-26-2010.  
 3,940,067. **ACTIONBOX (STANDARD CHARACTER)**. SPI INTERNATIONAL B.V., (U.S. CLS. 100, 101 AND 104). SN 79-087,648. PUB. 1-18-2011. FILED 8-26-2010.  
 3,940,068. **FASHIONBOX (STANDARD CHARACTER)**. SPI INTERNATIONAL B.V., (U.S. CLS. 100, 101 AND 104). SN 79-087,649. PUB. 1-18-2011. FILED 8-26-2010.  
 3,940,077 ( *See Class 9 for this trademark* ).  
 3,940,110. **WINEANDMUSIC.COM AND DESIGN**. DUBOC, CAROL, MULTIPLE CLASS, (INT. CLS. 38 AND 41), (U.S. CLS. 100, 101, 104 AND 107). SN 85-015,300. PUB. 1-18-2011. FILED 4-15-2010.  
 3,940,148 ( *See Class 9 for this trademark* ).  
 3,940,151. **INFOGROUP AND DESIGN**. INFOGROUP INC., (U.S. CLS. 100, 101 AND 104). SN 85-033,129. PUB. 1-18-2011. FILED 5-7-2010.  
 3,940,152. **INFOGROUP (STANDARD CHARACTER)**. INFOGROUP INC., (U.S. CLS. 100, 101 AND 104). SN 85-033,140. PUB. 1-18-2011. FILED 5-7-2010.  
 3,940,356. **BADLANDS 94.7 FM (STANDARD CHARACTER)**. CHAMPIONSHIP COMMUNICATIONS, (U.S. CLS. 100, 101 AND 104). SN 85-088,558. PUB. 1-18-2011. FILED 7-20-2010.  
 3,940,369. **OPINIONSEA AND DESIGN**. OPINIONSEA, LLC, (U.S. CLS. 100, 101 AND 104). SN 85-091,064. PUB. 1-18-2011. FILED 7-22-2010.  
 3,940,552. **GOT SOMETHING TO SAY? SAY IT! (STANDARD CHARACTER)**. RIVALROO, INC., (U.S. CLS. 100, 101 AND 104). SN 85-098,634. PUB. 1-18-2011. FILED 8-3-2010.  
 3,940,570. **AVAIL247 (STANDARD CHARACTER)**. IMER-

## CLASS 38—COMMUNICATION

- 3,939,350 ( *See Class 37 for this trademark* ).  
 3,939,394 ( *See Class 16 for this trademark* ).  
 3,939,397. **INSIDERMEDICINE GET THE DOCTORS' TAKE AND DESIGN**. COST EFFECTIVE HEALTHCARE INC., (U.S. CLS. 100, 101 AND 104). SN 77-193,155. PUB. 10-12-2010. FILED 5-30-2007.  
 3,939,494. **LIVEWIRE.ORG.AU AND DESIGN**. STARLIGHT CHILDREN'S FOUNDATION AUSTRALIA, MULTIPLE

- GENT, INC., MULTIPLE CLASS, (INT. CLS. 38 AND 42), (U.S. CLS. 100, 101 AND 104). SN 85-098,902. PUB. 1-18-2011. FILED 8-3-2010.
- 3,940,611. **GOMORHEAD (STANDARD CHARACTER)**. VAL-ED JOINT VENTURE LLP, DBA 702 COMMUNICATIONS, (U.S. CLS. 100, 101 AND 104). SN 85-099,673. PUB. 1-18-2011. FILED 8-4-2010.
- 3,940,635. **HY, O BOH ! AND DESIGN**. RUSSTEL S.A., LTD., (U.S. CLS. 100, 101 AND 104). SN 85-099,997. PUB. 1-18-2011. FILED 8-4-2010.
- 3,940,685. **OKWAVE (STANDARD CHARACTER)**. OKWAVE, MULTIPLE CLASS, (INT. CLS. 38 AND 42), (U.S. CLS. 100, 101 AND 104). SN 85-100,637. PUB. 1-18-2011. FILED 8-5-2010.
- 3,940,744. **SYOPTICS NETWORKS IS SPEED TO MARKET (STANDARD CHARACTER)**. SYOPTICS NETWORKS, (U.S. CLS. 100, 101 AND 104). SN 85-101,457. PUB. 1-18-2011. FILED 8-5-2010.
- 3,940,745. **YOU, THE WORLD, CONNECTED. (STANDARD CHARACTER)**. SYOPTICS NETWORKS, (U.S. CLS. 100, 101 AND 104). SN 85-101,458. PUB. 1-18-2011. FILED 8-5-2010.
- 3,940,757. **SYOPTICS NETWORKS (STANDARD CHARACTER)**. SYOPTICS NETWORKS, (U.S. CLS. 100, 101 AND 104). SN 85-101,558. PUB. 1-18-2011. FILED 8-5-2010.
- 3,940,791. **LIVESHARE (STANDARD CHARACTER)**. COOL-IRIS, INC., (U.S. CLS. 100, 101 AND 104). SN 85-102,202. PUB. 1-18-2011. FILED 8-6-2010.
- 3,940,806. **VAESTRO (STANDARD CHARACTER)**. VAESTRO, LLC, (U.S. CLS. 100, 101 AND 104). SN 85-102,420. PUB. 1-18-2011. FILED 8-6-2010.
- 3,940,851. **COTTON'S REVOLUTIONS (STANDARD CHARACTER)**. COTTON COUNCIL INTERNATIONAL, (U.S. CLS. 100, 101 AND 104). SN 85-103,472. PUB. 1-18-2011. FILED 8-9-2010.
- 3,940,879. **AVAIL24 7 AND DESIGN**. IMERGENT, INC., MULTIPLE CLASS, (INT. CLS. 38 AND 42), (U.S. CLS. 100, 101 AND 104). SN 85-109,060. PUB. 1-18-2011. FILED 8-17-2010.
- 3,940,959. **SYOPTICS (STANDARD CHARACTER)**. SYOPTICS NETWORKS, (U.S. CLS. 100, 101 AND 104). SN 85-143,017. PUB. 1-18-2011. FILED 10-1-2010.
- ... **"TO MANAGE OUR CUSTOMERS' BUSINESS."** (STANDARD CHARACTER). ALLIANCE SHIPPERS, INC, (U.S. CLS. 100 AND 105). SN 85-091,564. PUB. 1-18-2011. FILED 7-23-2010.
- 3,940,380. **EARTH UNBOUND (STYLIZED)**. LEE, DAVID G, (U.S. CLS. 100 AND 105). SN 85-092,298. PUB. 1-18-2011. FILED 7-25-2010.
- 3,940,381. **DESERTJET AND DESIGN**. DESERT JET, LLC, DBA DESERT JET, (U.S. CLS. 100 AND 105). SN 85-092,300. PUB. 1-18-2011. FILED 7-25-2010.
- 3,940,557. **WE MAKE FLYING A BREEZE (STANDARD CHARACTER)**. TOWN OF ISLIP, (U.S. CLS. 100 AND 105). SN 85-098,692. PUB. 1-18-2011. FILED 8-3-2010.
- 3,940,564. **BUSINESS TRAVEL HOUNDS AND DESIGN**. BUSINESS TRAVEL HOUNDS, LLC, (U.S. CLS. 100 AND 105). SN 85-098,823. PUB. 1-18-2011. FILED 8-3-2010.
- 3,940,566. **NEW KAM LAI (STANDARD CHARACTER)**. DONG, YONG HUI, MULTIPLE CLASS, (INT. CLS. 39 AND 43), (U.S. CLS. 100, 101 AND 105). SN 85-098,851. PUB. 1-18-2011. FILED 8-3-2010.
- 3,940,598. **ZUNZUN EDUCATION SERVICES AND DESIGN**. ZUNZUN EDUCATION SERVICES INC, (U.S. CLS. 100 AND 105). SN 85-099,480. PUB. 1-18-2011. FILED 8-3-2010.
- 3,940,620 ( *See Class 25 for this trademark*).
- 3,940,621 ( *See Class 25 for this trademark*).
- 3,940,760. **SSM AND DESIGN**. SMALLS & SMALLS MOVERS LLC, (U.S. CLS. 100 AND 105). SN 85-101,570. PUB. 1-18-2011. FILED 8-5-2010.
- 3,940,829. **FRESHNET (STYLIZED)**. CARGO IN ACTION!, CORP., DBA FRESHNET, (U.S. CLS. 100 AND 105). SN 85-102,644. PUB. 1-18-2011. FILED 8-8-2010.
- 3,940,890. **GOENVOY (STANDARD CHARACTER)**. US AIRWAYS, INC., (U.S. CLS. 100 AND 105). SN 85-111,219. PUB. 1-18-2011. FILED 8-19-2010.
- 3,940,942. **SONAIR (STANDARD CHARACTER)**. SOCIEDADE NACIONAL DE COMBUSTIVEIS DE ANGOLA SONANGOL EP, (U.S. CLS. 100 AND 105). SN 85-129,399. PUB. 1-18-2011. FILED 9-14-2010.
- 3,940,967. **WWW.FLYLIMA.COM (STANDARD CHARACTER)**. TOWN OF ISLIP, (U.S. CLS. 100 AND 105). SN 85-154,905. PUB. 1-18-2011. FILED 10-18-2010.
- 3,940,973. **FLY INTERNATIONAL GROUPTRAVEL AND DESIGN**. AUTO EUROPE, LLC, (U.S. CLS. 100 AND 105). SN 85-170,359. PUB. 1-18-2011. FILED 11-5-2010.

### CLASS 39—TRANSPORTATION AND STORAGE

- 3,939,426 ( *See Class 32 for this trademark*).
- 3,939,438. **PALLETIZED P TRUCKING INC. AND DESIGN**. PALLETIZED TRUCKING INC., (U.S. CLS. 100 AND 105). SN 77-599,412. PUB. 1-18-2011. FILED 10-23-2008.
- 3,939,448 ( *See Class 35 for this trademark*).
- 3,939,506 ( *See Class 9 for this trademark*).
- 3,939,692. **INDEPENDENT LIVING SYSTEMS (STANDARD CHARACTER)**. INDEPENDENT LIVING SYSTEMS, LLC, (U.S. CLS. 100 AND 105). SN 77-930,567. PUB. 1-18-2011. FILED 2-8-2010.
- 3,939,890 ( *See Class 9 for this trademark*).
- 3,939,892. **SNOWTREX (STANDARD CHARACTER)**. TRAVELTREX GMBH, (U.S. CLS. 100 AND 105). SN 79-069,018. PUB. 1-18-2011. FILED 2-11-2009.
- 3,939,899 ( *See Class 9 for this trademark*).
- 3,939,912 ( *See Class 7 for this trademark*).
- 3,939,915 ( *See Class 35 for this trademark*).
- 3,939,923 ( *See Class 36 for this trademark*).
- 3,939,931 ( *See Class 14 for this trademark*).
- 3,939,964 ( *See Class 35 for this trademark*).
- 3,939,981 ( *See Class 1 for this trademark*).
- 3,940,049 ( *See Class 32 for this trademark*).
- 3,940,107 ( *See Class 35 for this trademark*).
- 3,940,153 ( *See Class 12 for this trademark*).
- 3,940,354. **FGM MOVING AND DESIGN**. FGM WORLDWIDE MOVERS & LOGISTICS, INC., (U.S. CLS. 100 AND 105). SN 85-088,451. PUB. 1-18-2011. FILED 7-20-2010.
- 3,940,365. **FREEDOMCAR AND DESIGN**. FREEDOM SERVICES, INC., (U.S. CLS. 100 AND 105). SN 85-090,320. PUB. 1-18-2011. FILED 7-22-2010.
- 3,940,375. **THE BUSINESS OF ALLIANCE SHIPPERS, INC IS**

### CLASS 40—MATERIAL TREATMENT

- 3,939,507 ( *See Class 7 for this trademark*).
- 3,939,516 ( *See Class 9 for this trademark*).
- 3,939,529 ( *See Class 20 for this trademark*).
- 3,939,531 ( *See Class 20 for this trademark*).
- 3,939,542. **SURYA EMPOWERING LIFE AND DESIGN**. SURYA PHARMACEUTICAL, INC., AKA SURYA PHARMACEUTICAL LIMITED, (U.S. CLS. 100, 103 AND 106). SN 77-820,813. PUB. 1-18-2011. FILED 9-4-2009.
- 3,939,630. **FULL FUSION (STANDARD CHARACTER)**. VER-SATRANS, INC., (U.S. CLS. 100, 103 AND 106). SN 77-914,909. PUB. 1-18-2011. FILED 1-19-2010.
- 3,939,668. **BUSY AND BLESSED AND DESIGN**. BUSY AND BLESSED, (U.S. CLS. 100, 103 AND 106). SN 77-924,244. PUB. 1-18-2011. FILED 1-30-2010.
- 3,939,767. **PICTUREMYCARD.COM (STANDARD CHARACTER)**. TEAM ONE CREDIT UNION, (U.S. CLS. 100, 103 AND 106). SN 77-945,051. PUB. 1-18-2011. FILED 2-25-2010.
- 3,939,783. **ENVIVA PELLETS AND DESIGN**. ENVIVA, LP, (U.S. CLS. 100, 103 AND 106). SN 77-949,619. PUB. 1-18-2011. FILED 3-3-2010.
- 3,939,802 ( *See Class 35 for this trademark*).
- 3,939,806 ( *See Class 37 for this trademark*).
- 3,939,810 ( *See Class 37 for this trademark*).
- 3,939,890 ( *See Class 9 for this trademark*).
- 3,939,900 ( *See Class 7 for this trademark*).
- 3,939,912 ( *See Class 7 for this trademark*).
- 3,939,937 ( *See Class 11 for this trademark*).
- 3,939,938 ( *See Class 11 for this trademark*).
- 3,939,941 ( *See Class 12 for this trademark*).

3,939,944 ( *See Class 11 for this trademark* ).  
 3,939,945 ( *See Class 11 for this trademark* ).  
 3,939,946 ( *See Class 11 for this trademark* ).  
 3,939,981 ( *See Class 1 for this trademark* ).  
 3,940,011 ( *See Class 7 for this trademark* ).  
 3,940,035 ( *See Class 16 for this trademark* ).  
 3,940,059 ( *See Class 4 for this trademark* ).  
 3,940,061 ( *See Class 7 for this trademark* ).  
 3,940,181 ( *See Class 4 for this trademark* ).  
 3,940,197 ( *See Class 10 for this trademark* ).  
 3,940,229 ( *See Class 37 for this trademark* ).  
 3,940,234 ( *See Class 35 for this trademark* ).  
 3,940,238 ( *See Class 1 for this trademark* ).  
 3,940,240 ( *See Class 1 for this trademark* ).  
 3,940,261. **H M AND DESIGN**. HITCHINER MANUFACTURING CO., INC., (U.S. CLS. 100, 103 AND 106). SN 85-066,295. PUB. 1-18-2011. FILED 6-18-2010.  
 3,940,271. **DOMESTIC OFFSHORE MANUFACTURING (STANDARD CHARACTER)**. EAST WEST MANUFACTURING LLC, MULTIPLE CLASS, (INT. CLS. 40 AND 42), (U.S. CLS. 100, 101, 103 AND 106). SN 85-069,630. PUB. 1-18-2011. FILED 6-23-2010.  
 3,940,444. **AFS AND DESIGN**. ADVANCED FOOD SYSTEMS, INC., MULTIPLE CLASS, (INT. CLS. 40 AND 42), (U.S. CLS. 100, 101, 103 AND 106). SN 85-096,824. PUB. 1-18-2011. FILED 7-30-2010.  
 3,940,585. **GEONOVA (STANDARD CHARACTER)**. GEONOVA HOLDINGS, LTD. LLC, (U.S. CLS. 100, 103 AND 106). SN 85-099,262. PUB. 1-18-2011. FILED 8-3-2010.  
 3,940,822 ( *See Class 35 for this trademark* ).

#### CLASS 41—EDUCATION AND ENTERTAINMENT

3,939,349 ( *See Class 3 for this trademark* ).  
 3,939,394 ( *See Class 16 for this trademark* ).  
 3,939,406 ( *See Class 9 for this trademark* ).  
 3,939,409. **3D LET'S SCOOH NOW! SCO AND DESIGN**. DEMESA, ARMAN L., (U.S. CLS. 100, 101 AND 107). SN 77-340,683. PUB. 1-18-2011. FILED 11-29-2007.  
 3,939,413 ( *See Class 9 for this trademark* ).  
 3,939,414 ( *See Class 9 for this trademark* ).  
 3,939,426 ( *See Class 32 for this trademark* ).  
 3,939,428. **ANDERSEN ALUMNI (STANDARD CHARACTER)**. ANDERSEN ALUMNI ASSOCIATION, LLC, (U.S. CLS. 100, 101 AND 107). SN 77-536,095. PUB. 1-18-2011. FILED 7-31-2008.  
 3,939,429. **ANDERSEN ALUMNI AND DESIGN**. ANDERSEN ALUMNI ASSOCIATION, LLC, (U.S. CLS. 100, 101 AND 107). SN 77-536,163. PUB. 1-18-2011. FILED 7-31-2008.  
 3,939,433 ( *See Class 9 for this trademark* ).  
 3,939,435. **NORTH STAR CAMP FOR BOYS AND DESIGN**. CAMP NORTH STAR FOR BOYS, INC., (U.S. CLS. 100, 101 AND 107). SN 77-593,371. PUB. 11-2-2010. FILED 10-15-2008.  
 3,939,436. **NORTH STAR CAMP FOR BOYS (STANDARD CHARACTER)**. CAMP NORTH STAR FOR BOYS, INC., (U.S. CLS. 100, 101 AND 107). SN 77-593,378. PUB. 11-2-2010. FILED 10-15-2008.  
 3,939,441. **INTERGALACTIC MLS (STANDARD CHARACTER)**. BAY AREA REAL ESTATE INFORMATION SERVICES, INC., MULTIPLE CLASS, (INT. CLS. 41 AND 42), (U.S. CLS. 100, 101 AND 107). SN 77-626,378. PUB. 1-18-2011. FILED 12-4-2008.  
 3,939,446 ( *See Class 9 for this trademark* ).  
 3,939,447 ( *See Class 9 for this trademark* ).  
 3,939,450. **MISCELLANEOUS DESIGN**. COMPUTER MENTORS GROUP, INC., MULTIPLE CLASS, (INT. CLS. 41 AND 42), (U.S. CLS. 100, 101 AND 107). SN 77-645,954. PUB. 1-18-2011. FILED 1-8-2009.  
 3,939,451. **LIBERTY MOUNTAIN (STANDARD CHARACTER)**. LIBERTY UNIVERSITY, INC., (U.S. CLS. 100, 101 AND 107). SN 77-648,519. PUB. 1-18-2011. FILED 1-13-2009.  
 3,939,461 ( *See Class 3 for this trademark* ).  
 3,939,466 ( *See Class 16 for this trademark* ).  
 3,939,480. **ALEXIS TEXAS (STANDARD CHARACTER)**. ALEXIS TEXAS ENTERTAINMENT, (U.S. CLS. 100, 101

AND 107). SN 77-737,234. PUB. 1-18-2011. FILED 5-14-2009.  
 3,939,481 ( *See Class 5 for this trademark* ).  
 3,939,488. **MC MOTOR CITY RIDERS AND DESIGN**. MOTOR CITY RIDERS, (U.S. CLS. 100, 101 AND 107). SN 77-752,232. PUB. 1-18-2011. FILED 6-4-2009.  
 3,939,490 ( *See Class 6 for this trademark* ).  
 3,939,492. **JUDGE GREG MATHIS (STANDARD CHARACTER)**. GREG MATHIS, (U.S. CLS. 100, 101 AND 107). SN 77-763,059. PUB. 1-18-2011. FILED 6-18-2009.  
 3,939,494 ( *See Class 38 for this trademark* ).  
 3,939,496. **NINA BROWN (STANDARD CHARACTER)**. SOLOMON, RENE P., (U.S. CLS. 100, 101 AND 107). SN 77-769,185. PUB. 1-18-2011. FILED 6-26-2009.  
 3,939,497 ( *See Class 36 for this trademark* ).  
 3,939,498 ( *See Class 36 for this trademark* ).  
 3,939,502 ( *See Class 9 for this trademark* ).  
 3,939,503. **REAL MEDICINE (STANDARD CHARACTER)**. REAL MEDICINE INC., MULTIPLE CLASS, (INT. CLS. 41 AND 44), (U.S. CLS. 100, 101 AND 107). SN 77-784,738. PUB. 1-18-2011. FILED 7-20-2009.  
 3,939,521 ( *See Class 35 for this trademark* ).  
 3,939,522 ( *See Class 35 for this trademark* ).  
 3,939,526 ( *See Class 9 for this trademark* ).  
 3,939,527 ( *See Class 35 for this trademark* ).  
 3,939,536 ( *See Class 9 for this trademark* ).  
 3,939,543 ( *See Class 9 for this trademark* ).  
 3,939,567 ( *See Class 24 for this trademark* ).  
 3,939,580. **MISCELLANEOUS DESIGN**. HCR HEALTHCARE, LLC, MULTIPLE CLASS, (INT. CLS. 41 AND 44), (U.S. CLS. 100, 101 AND 107). SN 77-868,155. PUB. 10-12-2010. FILED 11-9-2009.  
 3,939,584 ( *See Class 35 for this trademark* ).  
 3,939,586 ( *See Class 9 for this trademark* ).  
 3,939,591 ( *See Class 9 for this trademark* ).  
 3,939,593. **FANTASY FOOTBALL (STANDARD CHARACTER)**. ROCK BOTTOM RESTAURANTS, INC., (U.S. CLS. 100, 101 AND 107). SN 77-882,212. PUB. 1-18-2011. FILED 11-30-2009.  
 3,939,595. **WORDS ARE WINGS (STANDARD CHARACTER)**. MICELI, ANDREW, MULTIPLE CLASS, (INT. CLS. 41 AND 44), (U.S. CLS. 100, 101 AND 107). SN 77-882,991. PUB. 1-18-2011. FILED 12-1-2009.  
 3,939,606 ( *See Class 36 for this trademark* ).  
 3,939,614. **NETIP (STANDARD CHARACTER)**. NETWORK OF INDIAN PROFESSIONALS OF NORTH AMERICA, INC., (U.S. CLS. 100, 101 AND 107). SN 77-901,918. PUB. 1-18-2011. FILED 12-29-2009.  
 3,939,617. **PROTOCOL & DIPLOMACY INTERNATIONAL PROTOCOL OFFICERS ASSOCIATION AND DESIGN**. PROTOCOL & DIPLOMACY INTERNATIONAL - PROTOCOL OFFICERS ASSOCIATION (PDI-POA), (U.S. CLS. 100, 101 AND 107). SN 77-902,907. PUB. 1-18-2011. FILED 12-30-2009.  
 3,939,619 ( *See Class 9 for this trademark* ).  
 3,939,634. **IRON HORSE RODEO (STANDARD CHARACTER)**. LEO WILSON, (U.S. CLS. 100, 101 AND 107). SN 77-915,942. PUB. 1-18-2011. FILED 1-20-2010.  
 3,939,653. **RO RUGGED OAK RANCH AND DESIGN**. DIESTE, ROBERT ANTHONY, (U.S. CLS. 100, 101 AND 107). SN 77-922,265. PUB. 1-18-2011. FILED 1-28-2010.  
 3,939,656 ( *See Class 35 for this trademark* ).  
 3,939,659. **THE HARE KRISHNA MOVEMENT INTERNATIONAL SOCIETY FOR KRISHNA CONSCIOUSNESS FOUNDER-ACHARYA HIS DIVINE GRACE A. C. BHAKTIVEDANTA SWAMI PRABHUPADA AND DESIGN**. ISKCON GOVERNING BODY COMMISSION, MULTIPLE CLASS, (INT. CLS. 41 AND 45 AND U.S. CL. 200), (U.S. CLS. 100, 101 AND 107). SN 77-923,248. PUB. 1-18-2011. FILED 1-29-2010.  
 3,939,665 ( *See Class 35 for this trademark* ).  
 3,939,687. **LIQUID 5TH (STANDARD CHARACTER)**. TAYLOR, CARL, (U.S. CLS. 100, 101 AND 107). SN 77-929,725. PUB. 1-18-2011. FILED 2-6-2010.  
 3,939,691. **TESOL JOURNAL (STANDARD CHARACTER)**. TEACHERS OF ENGLISH TO SPEAKERS OF OTHER LANGUAGES, INC., (U.S. CLS. 100, 101 AND 107). SN 77-930,435. PUB. 1-18-2011. FILED 2-8-2010.  
 3,939,698 ( *See Class 9 for this trademark* ).

- 3,939,708. **RADICAL SELF CARE (STANDARD CHARACTER)**. DAVIS-HOLLANDER, MARGO, (U.S. CLS. 100, 101 AND 107). SN 77-934,423. PUB. 1-18-2011. FILED 2-12-2010.
- 3,939,712. **PROPICK RACING (STANDARD CHARACTER)**. PROPICK RACING, LLC, (U.S. CLS. 100, 101 AND 107). SN 77-935,244. PUB. 1-18-2011. FILED 2-13-2010.
- 3,939,722. **LEARN IT! LIVE IT! SHARE IT! (STANDARD CHARACTER)**. INNERLINK, INC., (U.S. CLS. 100, 101 AND 107). SN 77-936,328. PUB. 1-18-2011. FILED 2-16-2010.
- 3,939,730 ( *See Class 16 for this trademark*).
- 3,939,737. **PURPLESOUL (STANDARD CHARACTER)**. KURTZ, AIMEE, (U.S. CLS. 100, 101 AND 107). SN 77-937,987. PUB. 1-18-2011. FILED 2-17-2010.
- 3,939,739. **FES FUNDAMENTALS OF ENDOSCOPIC AND DESIGN**. SOCIETY OF AMERICAN GASTROINTESTINAL AND ENDOSCOPIC SURGEONS (SAGES), (U.S. CLS. 100, 101 AND 107). SN 77-938,285. PUB. 1-18-2011. FILED 2-17-2010.
- 3,939,742. **BRAD SUGARS (STANDARD CHARACTER)**. ACTIONCOACH LIMITED, (U.S. CLS. 100, 101 AND 107). SN 77-938,570. PUB. 1-18-2011. FILED 2-18-2010.
- 3,939,746 ( *See Class 16 for this trademark*).
- 3,939,748. **DIMEDEX (STANDARD CHARACTER)**. AMERICAN ASSOCIATION OF DIABETES EDUCATORS, INC., (U.S. CLS. 100, 101 AND 107). SN 77-939,931. PUB. 1-18-2011. FILED 2-19-2010.
- 3,939,750 ( *See Class 25 for this trademark*).
- 3,939,751. **WOMEN'S INSTITUTE FOR LEADERSHIP AT BRYANT UNIVERSITY (STANDARD CHARACTER)**. BRYANT UNIVERSITY, EXECUTIVE DEVELOPMENT CENTER, (U.S. CLS. 100, 101 AND 107). SN 77-940,057. PUB. 1-18-2011. FILED 2-19-2010.
- 3,939,764. **I SQUARE (STANDARD CHARACTER)**. I SQUARE ENTERTAINMENT, LLC, (U.S. CLS. 100, 101 AND 107). SN 77-943,725. PUB. 1-18-2011. FILED 2-24-2010.
- 3,939,770. **VIRTUOUS POST (STANDARD CHARACTER)**. NORTHSHORE GLOBAL HOLDINGS, LLC, (U.S. CLS. 100, 101 AND 107). SN 77-945,625. PUB. 1-18-2011. FILED 2-26-2010.
- 3,939,775. **RELLIK (STANDARD CHARACTER)**. DIZY ENTERPRISES, LLC, MULTIPLE CLASS, (INT. CLS. 41 AND 43), (U.S. CLS. 100, 101 AND 107). SN 77-946,289. PUB. 1-18-2011. FILED 2-26-2010.
- 3,939,776. **MISCELLANEOUS DESIGN**. ADOBE SPRINGS WATER CO., (U.S. CLS. 100, 101 AND 107). SN 77-946,757. PUB. 1-18-2011. FILED 2-28-2010.
- 3,939,777 ( *See Class 9 for this trademark*).
- 3,939,790. **THE ONCOFERTILITY CONSORTIUM SATURDAY ACADEMY AND DESIGN**. NORTHWESTERN UNIVERSITY, (U.S. CLS. 100, 101 AND 107). SN 77-950,861. PUB. 1-18-2011. FILED 3-4-2010.
- 3,939,796 ( *See Class 16 for this trademark*).
- 3,939,802 ( *See Class 35 for this trademark*).
- 3,939,804. **MCCRORY GARDENS (STANDARD CHARACTER)**. SOUTH DAKOTA STATE UNIVERSITY, (U.S. CLS. 100, 101 AND 107). SN 77-955,888. PUB. 1-18-2011. FILED 3-10-2010.
- 3,939,811. **PAHEF (STANDARD CHARACTER)**. PAN AMERICAN HEALTH AND EDUCATION FOUNDATION, AKA PAHEF, MULTIPLE CLASS, (INT. CLS. 41, 42 AND 44), (U.S. CLS. 100, 101 AND 107). SN 77-957,308. PUB. 1-18-2011. FILED 3-12-2010.
- 3,939,815 ( *See Class 9 for this trademark*).
- 3,939,820. **MATT LAMB (STANDARD CHARACTER)**. MATT LAMB STUDIOS, (U.S. CLS. 100, 101 AND 107). SN 77-959,536. PUB. 1-18-2011. FILED 3-15-2010.
- 3,939,827. **STATEMENT ANALYSIS (STANDARD CHARACTER)**. MCCLISH, MARK A, (U.S. CLS. 100, 101 AND 107). SN 77-961,638. PUB. 1-18-2011. FILED 3-17-2010.
- 3,939,831 ( *See Class 38 for this trademark*).
- 3,939,838 ( *See Class 16 for this trademark*).
- 3,939,839 ( *See Class 36 for this trademark*).
- 3,939,850 ( *See Class 35 for this trademark*).
- 3,939,858. **MAKING SCIENCE USER-FRIENDLY (STANDARD CHARACTER)**. SCIENCEFRIDAY, INC., (U.S. CLS. 100, 101 AND 107). SN 77-969,292. PUB. 1-18-2011. FILED 3-26-2010.
- 3,939,860. **JERSEY SHORE HO'S: SEX ON THE BEACH (STANDARD CHARACTER)**. KAREL, STEVEN, (U.S. CLS. 100, 101 AND 107). SN 77-980,136. PUB. 10-5-2010. FILED 3-4-2010.
- 3,939,865. **NEW ORLEANS LIVE AND DESIGN**. RESA WILSON BAZILE, (U.S. CLS. 100, 101 AND 107). SN 78-477,468. PUB. 1-18-2011. FILED 9-1-2004.
- 3,939,874. **SO CAL CROSS CX AND DESIGN**. WONG, DOROTHY, (U.S. CLS. 100, 101 AND 107). SN 78-874,844. PUB. 12-5-2006. FILED 5-2-2006.
- 3,939,875. **THE VOYAGE (STANDARD CHARACTER)**. KOCH DEVELOPMENT CORPORATION, (U.S. CLS. 100, 101 AND 107). SN 78-882,694. PUB. 1-18-2011. FILED 5-12-2006.
- 3,939,885. **NOVO NORDISK CARE (STANDARD CHARACTER)**. NOVO NORDISK A/S, (U.S. CLS. 100, 101 AND 107). SN 79-061,822. PUB. 1-18-2011. FILED 10-23-2008.
- 3,939,890 ( *See Class 9 for this trademark*).
- 3,939,902 ( *See Class 35 for this trademark*).
- 3,939,913 ( *See Class 3 for this trademark*).
- 3,939,922 ( *See Class 14 for this trademark*).
- 3,939,925 ( *See Class 9 for this trademark*).
- 3,939,931 ( *See Class 14 for this trademark*).
- 3,939,955 ( *See Class 12 for this trademark*).
- 3,939,975 ( *See Class 9 for this trademark*).
- 3,939,997 ( *See Class 16 for this trademark*).
- 3,939,999 ( *See Class 6 for this trademark*).
- 3,940,021 ( *See Class 9 for this trademark*).
- 3,940,056 ( *See Class 9 for this trademark*).
- 3,940,060 ( *See Class 28 for this trademark*).
- 3,940,081. **AMERICAN SOCIETY OF OPHTHALMIC PLASTIC & RECONSTRUCTIVE SURGERY (STANDARD CHARACTER)**. AMERICAN SOCIETY OF OPHTHALMIC PLASTIC & RECONSTRUCTIVE SURGERY, INC., (U.S. CLS. 100, 101 AND 107). SN 85-002,238. PUB. 1-18-2011. FILED 3-30-2010.
- 3,940,096. **COAL PREP INTERNATIONAL (STANDARD CHARACTER)**. PENTON BUSINESS MEDIA, INC., (U.S. CLS. 100, 101 AND 107). SN 85-008,447. PUB. 1-18-2011. FILED 4-7-2010.
- 3,940,099. **NATIONWIDE STUDIOS INC AND DESIGN**. NATIONWIDE STUDIOS, (U.S. CLS. 100, 101 AND 107). SN 85-011,968. PUB. 1-18-2011. FILED 4-12-2010.
- 3,940,101. **SOCIALPREP STUDY TOGETHER. SUCCEED TOGETHER. AND DESIGN**. BTG TEST PREP, LLC, (U.S. CLS. 100, 101 AND 107). SN 85-013,253. PUB. 1-18-2011. FILED 4-13-2010.
- 3,940,110 ( *See Class 38 for this trademark*).
- 3,940,116 ( *See Class 35 for this trademark*).
- 3,940,119. **PAUSE BEFORE YOU PLAY AND DESIGN**. THE CANDIE'S FOUNDATION, (U.S. CLS. 100, 101 AND 107). SN 85-018,043. PUB. 1-18-2011. FILED 4-20-2010.
- 3,940,121. **NASCAR HOME TRACKS AND DESIGN**. NATIONAL ASSOCIATION FOR STOCK CAR AUTO RACING, INC., (U.S. CLS. 100, 101 AND 107). SN 85-020,392. PUB. 1-18-2011. FILED 4-22-2010.
- 3,940,126. **IMPACT PERSONAL SAFETY SOUTHERN CALIFORNIA AND DESIGN**. IMPACT PERSONAL SAFETY, INC., (U.S. CLS. 100, 101 AND 107). SN 85-023,539. PUB. 1-18-2011. FILED 4-26-2010.
- 3,940,137 ( *See Class 35 for this trademark*).
- 3,940,139 ( *See Class 35 for this trademark*).
- 3,940,153 ( *See Class 12 for this trademark*).
- 3,940,156. **MISCELLANEOUS DESIGN**. EMUSIC.COM INC., (U.S. CLS. 100, 101 AND 107). SN 85-035,356. PUB. 1-18-2011. FILED 5-11-2010.
- 3,940,175. **COLOR SOUNDATION (STANDARD CHARACTER)**. HORIPRO ENTERTAINMENT GROUP, INC., (U.S. CLS. 100, 101 AND 107). SN 85-040,984. PUB. 1-18-2011. FILED 5-18-2010.
- 3,940,180. **POLITICS OF GOD (STANDARD CHARACTER)**. MOTBN, INC., (U.S. CLS. 100, 101 AND 107). SN 85-042,352. PUB. 1-18-2011. FILED 5-19-2010.
- 3,940,182. **THE MATH LADY (STANDARD CHARACTER)**. MATH 1 ON 1, LLC, (U.S. CLS. 100, 101 AND 107). SN 85-042,866. PUB. 1-18-2011. FILED 5-19-2010.
- 3,940,183. **THE IDEAL YOU (STANDARD CHARACTER)**. BRETT BAUGHMAN, (U.S. CLS. 100, 101 AND 107). SN 85-043,701. PUB. 1-18-2011. FILED 5-20-2010.
- 3,940,184. **LOS TERRICOLAS (STANDARD CHARACTER)**. NESTOR DANIEL HOYER, DBA LOS TERRICOLAS, (U.S.

- CLS. 100, 101 AND 107). SN 85-043,708. PUB. 1-18-2011. FILED 5-20-2010.
- 3,940,189. **MYIMPACT.ORG AND DESIGN**. MOBILIZING AMERICA'S YOUTH, (U.S. CLS. 100, 101 AND 107). SN 85-045,773. PUB. 1-18-2011. FILED 5-23-2010.
- 3,940,190. **ROCKFIGHT (STANDARD CHARACTER)**. MIDKIFF, DANIEL, L. (U.S. CLS. 100, 101 AND 107). SN 85-045,970. PUB. 1-18-2011. FILED 5-24-2010.
- 3,940,191. **KVC BUILDING YOUR SOLID FOUNDATION IN EDUCATION AND DESIGN**. PENNSYLVANIA VETERINARY FOUNDATION, (U.S. CLS. 100, 101 AND 107). SN 85-046,378. PUB. 1-18-2011. FILED 5-24-2010.
- 3,940,198 ( *See Class 35 for this trademark*).
- 3,940,204. **WINGNUTZ (STANDARD CHARACTER)**. GOOD BIRD, INC., (U.S. CLS. 100, 101 AND 107). SN 85-050,419. PUB. 1-18-2011. FILED 5-28-2010.
- 3,940,207. **OFF THE HOOK COMEDY CLUB (STANDARD CHARACTER)**. SPINA, BRIEN S., DBA OFF THE HOOK COMEDY CLUB, (U.S. CLS. 100, 101 AND 107). SN 85-051,749. PUB. 1-18-2011. FILED 6-1-2010.
- 3,940,210. **ARTEAMERICAS (STANDARD CHARACTER)**. ARTE AMERICAS, INC., (U.S. CLS. 100, 101 AND 107). SN 85-051,924. PUB. 1-18-2011. FILED 6-1-2010.
- 3,940,225. **WORLD MIXED MARTIAL ARTS FEDERATION (STANDARD CHARACTER)**. HAIMOVICI, ALEK, (U.S. CLS. 100, 101 AND 107). SN 85-056,906. PUB. 1-18-2011. FILED 6-8-2010.
- 3,940,236 ( *See Class 35 for this trademark*).
- 3,940,237. **SPACE CITY FILMS (STANDARD CHARACTER)**. SPACE CITY FILMS, (U.S. CLS. 100, 101 AND 107). SN 85-059,804. PUB. 1-18-2011. FILED 6-10-2010.
- 3,940,246. **MINDBODY FX UNCOVER THE MISSING LINK TO WEIGHT LOSS! AND DESIGN**. MIND BODY FX WEIGHT MANAGEMENT COMPANY INC., (U.S. CLS. 100, 101 AND 107). SN 85-063,899. PUB. 1-18-2011. FILED 6-16-2010.
- 3,940,248 ( *See Class 9 for this trademark*).
- 3,940,249 ( *See Class 9 for this trademark*).
- 3,940,250 ( *See Class 9 for this trademark*).
- 3,940,251 ( *See Class 9 for this trademark*).
- 3,940,252 ( *See Class 9 for this trademark*).
- 3,940,254 ( *See Class 35 for this trademark*).
- 3,940,264. **AWARENESS. ACCEPTANCE. EMPATHY. (STANDARD CHARACTER)**. GOOD FRIEND INC., (U.S. CLS. 100, 101 AND 107). SN 85-068,274. PUB. 1-18-2011. FILED 6-22-2010.
- 3,940,270. **DRINK BRAVELY (STANDARD CHARACTER)**. OLDMAN, MARK, DBA WETAKEM, LLC, (U.S. CLS. 100, 101 AND 107). SN 85-069,629. PUB. 1-18-2011. FILED 6-23-2010.
- 3,940,278. **AM (STYLIZED)**. BOARD OF TRUSTEES OF THE UNIVERSITY OF ARKANSAS, (U.S. CLS. 100, 101 AND 107). SN 85-071,886. PUB. 1-18-2011. FILED 6-25-2010.
- 3,940,279. **COLOR SOUNDATION AND DESIGN**. HORIPRO ENTERTAINMENT GROUP, INC., (U.S. CLS. 100, 101 AND 107). SN 85-072,425. PUB. 1-18-2011. FILED 6-27-2010.
- 3,940,280 ( *See Class 25 for this trademark*).
- 3,940,282. **REBELS HONKY TONK AND DESIGN**. JUSTIN Z. TRUESDELL, DBA REBELS HONKY TONK, (U.S. CLS. 100, 101 AND 107). SN 85-072,719. PUB. 1-18-2011. FILED 6-28-2010.
- 3,940,309. **MISCELLANEOUS DESIGN**. YOUNGSTOWN STEEL HERITAGE FOUNDATION, (U.S. CLS. 100, 101 AND 107). SN 85-080,978. PUB. 1-18-2011. FILED 7-9-2010.
- 3,940,321. **DISCOVERY U . CALIFORNIA BAPTIST UNIVERSITY . DISCOVER YOUR PURPOSE AND DESIGN**. CALIFORNIA BAPTIST UNIVERSITY, (U.S. CLS. 100, 101 AND 107). SN 85-082,888. PUB. 1-18-2011. FILED 7-12-2010.
- 3,940,328. **CURRENTS MCCORMICK PARK MISSOULA MT AND DESIGN**. CITY OF MISSOULA, DBA CURRENTS, (U.S. CLS. 100, 101 AND 107). SN 85-084,204. PUB. 1-18-2011. FILED 7-14-2010.
- 3,940,336 ( *See Class 16 for this trademark*).
- 3,940,337. **YOGA HARLEY GIRL AND DESIGN**. YOGA HARLEY GIRL LLC, (U.S. CLS. 100, 101 AND 107). SN 85-085,986. PUB. 1-18-2011. FILED 7-15-2010.
- 3,940,341 ( *See Class 16 for this trademark*).
- 3,940,346 ( *See Class 25 for this trademark*).
- 3,940,348. **STEREO CHOICE (STANDARD CHARACTER)**. CONNELL, OVID, AKA FATHER ONEKO, (U.S. CLS. 100, 101 AND 107). SN 85-087,837. PUB. 1-18-2011. FILED 7-19-2010.
- 3,940,351. **MAS DEPORTE (STANDARD CHARACTER)**. TEL-EVISA, S.A. DE C.V., (U.S. CLS. 100, 101 AND 107). SN 85-088,228. PUB. 1-18-2011. FILED 7-20-2010.
- 3,940,355 ( *See Class 35 for this trademark*).
- 3,940,359. **I'M A BEE SQUAD MEMBER BUMBLE BEE FOODS AND DESIGN**. BUMBLE BEE FOODS, LLC, (U.S. CLS. 100, 101 AND 107). SN 85-089,057. PUB. 1-18-2011. FILED 7-20-2010.
- 3,940,377 ( *See Class 16 for this trademark*).
- 3,940,379. **SYNERGY ADVISERS (STANDARD CHARACTER)**. ZOHAR, TIBI, (U.S. CLS. 100, 101 AND 107). SN 85-092,140. PUB. 1-18-2011. FILED 7-23-2010.
- 3,940,384. **K4 SALES SUCCESS FORMULA AND DESIGN**. NEAL AND ASSOCIATES BUSINESS CONSULTANTS, INC., (U.S. CLS. 100, 101 AND 107). SN 85-093,317. PUB. 1-18-2011. FILED 7-26-2010.
- 3,940,385. **TRANSFORMATIONAL WELLNESS (STANDARD CHARACTER)**. BOWMAN, THERESA CLARE, (U.S. CLS. 100, 101 AND 107). SN 85-093,373. PUB. 1-18-2011. FILED 7-27-2010.
- 3,940,392. **FANSPEAK (STANDARD CHARACTER)**. FANSPEAK, LLC, (U.S. CLS. 100, 101 AND 107). SN 85-093,641. PUB. 1-18-2011. FILED 7-27-2010.
- 3,940,396 ( *See Class 14 for this trademark*).
- 3,940,397. **HAIRDRESSER POWER AWARDS (STANDARD CHARACTER)**. USP, LLC, (U.S. CLS. 100, 101 AND 107). SN 85-094,186. PUB. 1-18-2011. FILED 7-27-2010.
- 3,940,403. **VIDEOWIRED (STANDARD CHARACTER)**. MOTIONLX, LLC, (U.S. CLS. 100, 101 AND 107). SN 85-094,292. PUB. 1-18-2011. FILED 7-27-2010.
- 3,940,410. **EDUCATIONBRIDGE (STANDARD CHARACTER)**. ACROSS WORLD EDUCATION, LLC, MULTIPLE CLASS, (INT. CLS. 41 AND 42), (U.S. CLS. 100, 101 AND 107). SN 85-094,651. PUB. 1-18-2011. FILED 7-28-2010.
- 3,940,421 ( *See Class 16 for this trademark*).
- 3,940,440. **MULLER FILM & TELEVISION EDUCATION FOUNDATION AND DESIGN**. MULLER FILM AND TELEVISION EDUCATION FOUNDATION, (U.S. CLS. 100, 101 AND 107). SN 85-096,592. PUB. 1-18-2011. FILED 7-30-2010.
- 3,940,441 ( *See Class 25 for this trademark*).
- 3,940,448. **EVERBLUE (STANDARD CHARACTER)**. EVERBLUE ENERGY, INC., MULTIPLE CLASS, (INT. CLS. 41 AND 42), (U.S. CLS. 100, 101 AND 107). SN 85-096,877. PUB. 1-18-2011. FILED 7-30-2010.
- 3,940,452. **THE MODCHIK AND DESIGN**. LAVA MARKETING INC., DBA THE MODCHIK, (U.S. CLS. 100, 101 AND 107). SN 85-097,064. PUB. 1-18-2011. FILED 7-30-2010.
- 3,940,453. **BATTLESHIP COVE (STANDARD CHARACTER)**. U.S.S. MASSACHUSETTS MEMORIAL COMMITTEE, INC., (U.S. CLS. 100, 101 AND 107). SN 85-097,111. PUB. 1-18-2011. FILED 7-30-2010.
- 3,940,454. **MANIFEST YOUR MAN (STANDARD CHARACTER)**. CORRIGAN, STACY, (U.S. CLS. 100, 101 AND 107). SN 85-097,159. PUB. 1-18-2011. FILED 7-30-2010.
- 3,940,456. **MYFIXITUPLIFE (STANDARD CHARACTER)**. CENTERLINE MEDIA, LLC, (U.S. CLS. 100, 101 AND 107). SN 85-097,191. PUB. 1-18-2011. FILED 7-30-2010.
- 3,940,461. **MARKT (STANDARD CHARACTER)**. TOWNSEND, MARK, (U.S. CLS. 100, 101 AND 107). SN 85-097,312. PUB. 1-18-2011. FILED 7-30-2010.
- 3,940,463. **MARKTBEAUTY (STANDARD CHARACTER)**. TOWNSEND, MARK, (U.S. CLS. 100, 101 AND 107). SN 85-097,318. PUB. 1-18-2011. FILED 7-30-2010.
- 3,940,472. **DAKINI SENSUAL MOVEMENT AND DESIGN**. DAKINI MOVEMENT LLC, (U.S. CLS. 100, 101 AND 107). SN 85-097,423. PUB. 1-18-2011. FILED 7-30-2010.
- 3,940,473 ( *See Class 9 for this trademark*).
- 3,940,479. **POWERPLAY COMMUNICATIONS AND DESIGN**. WALSH, MELISSA, DBA POWERPLAY COMMUNICATIONS, (U.S. CLS. 100, 101 AND 107). SN 85-097,487. PUB. 1-18-2011. FILED 7-31-2010.
- 3,940,484. **DR LEAF SWITCH ON YOUR BRAIN AND DESIGN**. SWOYB PROPERTIES, LP, (U.S. CLS. 100, 101 AND

- 107). SN 85-097,501. PUB. 1-18-2011. FILED 7-31-2010.
- 3,940,489. **ACTIONED (STANDARD CHARACTER)**. JOINT COMMISSION ON ALLIED HEALTH PERSONNEL IN OPHTHALMOLOGY, DBA JCAHPO, (U.S. CLS. 100, 101 AND 107). SN 85-097,589. PUB. 1-18-2011. FILED 7-31-2010.
- 3,940,490. **E.E. JUST ENVIRONMENTAL (STANDARD CHARACTER)**. KIMBALL UNION ACADEMY, (U.S. CLS. 100, 101 AND 107). SN 85-097,597. PUB. 1-18-2011. FILED 7-31-2010.
- 3,940,499. **EXPERIENCE NUTRITION (STANDARD CHARACTER)**. ALBERT, MELANIE ANNE, (U.S. CLS. 100, 101 AND 107). SN 85-097,701. PUB. 1-18-2011. FILED 8-1-2010.
- 3,940,508. **JR.FLL (STANDARD CHARACTER)**. UNITED STATES FOUNDATION FOR INSPIRATION AND RECOGNITION OF SCIENCE AND TECHNOLOGY, AKA US FIRST, AND LEGO SYSTEMS, INC. AKA LEGO CORPORATION CONNECTICUT, (U.S. CLS. 100, 101 AND 107). SN 85-097,825. PUB. 1-18-2011. FILED 8-2-2010.
- 3,940,509 ( *See Class 9 for this trademark*).
- 3,940,523. **VTOUR PLAY. POST. WIN! (STYLIZED)**. THE STRACKA DESIGN COMPANY, LLC, (U.S. CLS. 100, 101 AND 107). SN 85-098,141. PUB. 1-18-2011. FILED 8-2-2010.
- 3,940,524. **VTOUR (STANDARD CHARACTER)**. THE STRACKA DESIGN COMPANY, LLC, (U.S. CLS. 100, 101 AND 107). SN 85-098,147. PUB. 1-18-2011. FILED 8-2-2010.
- 3,940,526. **STUDY THE PAST. LIVE THE MOMENT. PLAN THE FUTURE. (STANDARD CHARACTER)**. BMD LEADERSHIP INSTITUTE, INC., (U.S. CLS. 100, 101 AND 107). SN 85-098,162. PUB. 1-18-2011. FILED 8-2-2010.
- 3,940,530. **SEATTITUDE AND DESIGN**. WEIRICH, DANIEL D., DBA SEATTITUDE, (U.S. CLS. 100, 101 AND 107). SN 85-098,309. PUB. 1-18-2011. FILED 8-2-2010.
- 3,940,531 ( *See Class 36 for this trademark*).
- 3,940,541. **CIRCULAR3D AND DESIGN**. INOUT SOFTWARE, LLC, MULTIPLE CLASS, (INT. CLS. 41 AND 42), (U.S. CLS. 100, 101 AND 107). SN 85-098,480. PUB. 1-18-2011. FILED 8-2-2010.
- 3,940,546. **NPCOLLEGE (STYLIZED)**. NATIONAL POLYTECHNIC COLLEGE, INC., (U.S. CLS. 100, 101 AND 107). SN 85-098,526. PUB. 1-18-2011. FILED 8-2-2010.
- 3,940,550. **TWINK! TUESDAYS (STANDARD CHARACTER)**. BOI PROMOTIONS INC., (U.S. CLS. 100, 101 AND 107). SN 85-098,621. PUB. 1-18-2011. FILED 8-3-2010.
- 3,940,553. **GREAT HALL (STANDARD CHARACTER)**. BURROUGHS, DAVID, (U.S. CLS. 100, 101 AND 107). SN 85-098,636. PUB. 1-18-2011. FILED 8-3-2010.
- 3,940,574. **KIDS OF CHARACTER AND DESIGN**. LA PETITE ACADEMY, INC., (U.S. CLS. 100, 101 AND 107). SN 85-098,984. PUB. 1-18-2011. FILED 8-3-2010.
- 3,940,581. **THE DAILY UNDERTAKER (STANDARD CHARACTER)**. MCNALLY, PATRICK JAMES, (U.S. CLS. 100, 101 AND 107). SN 85-099,165. PUB. 1-18-2011. FILED 8-3-2010.
- 3,940,586. **RESTORECORPS (STANDARD CHARACTER)**. BOAZ AND RUTH, INC., (U.S. CLS. 100, 101 AND 107). SN 85-099,272. PUB. 1-18-2011. FILED 8-3-2010.
- 3,940,592. **X-RAY LADY AND DESIGN**. JEANA FLEITZ, DBA X-RAY LADY, (U.S. CLS. 100, 101 AND 107). SN 85-099,352. PUB. 1-18-2011. FILED 8-3-2010.
- 3,940,594. **KINGS OF LEON (STANDARD CHARACTER)**. FOLLOWWILL MUSIC, INC., (U.S. CLS. 100, 101 AND 107). SN 85-099,394. PUB. 1-18-2011. FILED 8-3-2010.
- 3,940,600. **THE ANIMALS ARE WAITING (STANDARD CHARACTER)**. WEND-EN-EDEN, (U.S. CLS. 100, 101 AND 107). SN 85-099,505. PUB. 1-18-2011. FILED 8-3-2010.
- 3,940,608. **SWEET PEOPLE PHOTOGRAPHY (STANDARD CHARACTER)**. ELYSE CARDON PHOTOGRAPHY LLC, (U.S. CLS. 100, 101 AND 107). SN 85-099,654. PUB. 1-18-2011. FILED 8-4-2010.
- 3,940,609. **MAGIC CITY AND DESIGN**. -M- ENTERTAINMENT & CONSULTANT SERVICE, INC., (U.S. CLS. 100, 101 AND 107). SN 85-099,668. PUB. 1-18-2011. FILED 8-4-2010.
- 3,940,619. **TRUTH HONOR SERVICE 1842 MARION MILITARY INSTITUTE AND DESIGN**. THE MARION MILITARY INSTITUTE FOUNDATION, INC., (U.S. CLS. 100, 101 AND 107). SN 85-099,797. PUB. 1-18-2011. FILED 8-4-2010.
- 3,940,625. **SHAPING FAMILIES (STANDARD CHARACTER)**. MENNONITE BROADCASTS, INC., DBA THIRD WAY MEDIA, (U.S. CLS. 100, 101 AND 107). SN 85-099,921. PUB. 1-18-2011. FILED 8-4-2010.
- 3,940,655. **SOUL TUNER (STANDARD CHARACTER)**. CLARK, BARBARA, (U.S. CLS. 100, 101 AND 107). SN 85-100,201. PUB. 1-18-2011. FILED 8-4-2010.
- 3,940,661. **T TRIDENT AND DESIGN**. OBEROI HOTELS PVT. LIMITED, MULTIPLE CLASS, (INT. CLS. 41, 43 AND 44), (U.S. CLS. 100, 101 AND 107). SN 85-100,321. PUB. 1-18-2011. FILED 8-4-2010.
- 3,940,667. **THERE IS, SIMPLY, A BETTER WAY (STANDARD CHARACTER)**. PACIFIC SYSTEMS DESIGN TECHNOLOGIES, (U.S. CLS. 100, 101 AND 107). SN 85-100,391. PUB. 1-18-2011. FILED 8-4-2010.
- 3,940,668. **AFFABLE ENTERTAINMENT (STANDARD CHARACTER)**. FOSTER, SCOTT, (U.S. CLS. 100, 101 AND 107). SN 85-100,421. PUB. 1-18-2011. FILED 8-4-2010.
- 3,940,672. **NELARUSKY (STANDARD CHARACTER)**. NELARUSKY LLC, FORMERLY MCFEST LLC, (U.S. CLS. 100, 101 AND 107). SN 85-100,464. PUB. 1-18-2011. FILED 8-4-2010.
- 3,940,696. **ONE-EYED DOLL (STANDARD CHARACTER)**. ONE-EYED DOLL, (U.S. CLS. 100, 101 AND 107). SN 85-100,776. PUB. 1-18-2011. FILED 8-5-2010.
- 3,940,699. **NAMASTEENS (STANDARD CHARACTER)**. BENUSIS, LARA, (U.S. CLS. 100, 101 AND 107). SN 85-100,794. PUB. 1-18-2011. FILED 8-5-2010.
- 3,940,701. **AVIATION TECHNOLOGY INSTITUTE A DIVISION OF MIAT AND DESIGN**. MICHIGAN INSTITUTE OF AERONAUTICS, INC., (U.S. CLS. 100, 101 AND 107). SN 85-100,808. PUB. 1-18-2011. FILED 8-5-2010.
- 3,940,702. **POWER TECHNOLOGY INSTITUTE A DIVISION OF MIAT AND DESIGN**. MICHIGAN INSTITUTE OF AERONAUTICS, INC., (U.S. CLS. 100, 101 AND 107). SN 85-100,810. PUB. 1-18-2011. FILED 8-5-2010.
- 3,940,705. **THRIVE IN 30 (STANDARD CHARACTER)**. SEQUEL NATURALS INC., MULTIPLE CLASS, (INT. CLS. 41 AND 44), (U.S. CLS. 100, 101 AND 107). SN 85-100,894. PUB. 1-18-2011. FILED 8-5-2010.
- 3,940,710. **WHISKIPEDIA AND DESIGN**. MCCOMBER, KEVIN ANDREW, AND PENG, EILEEN XIAOFEI, (U.S. CLS. 100, 101 AND 107). SN 85-100,940. PUB. 1-18-2011. FILED 8-5-2010.
- 3,940,721. **MISCELLANEOUS DESIGN**. ESCUELA DE AGRICULTURA DE LA REGION TROPICAL HUMEDA, (U.S. CLS. 100, 101 AND 107). SN 85-101,022. PUB. 1-18-2011. FILED 8-5-2010.
- 3,940,723. **THE CONFERENCE FOR EXCELLENCE IN NURSING LEADERSHIP (STANDARD CHARACTER)**. WOLTERS KLUWER HEALTH, INC., (U.S. CLS. 100, 101 AND 107). SN 85-101,063. PUB. 1-18-2011. FILED 8-5-2010.
- 3,940,741. **HOLY BIRTH (STANDARD CHARACTER)**. A BIRTH CONSULTANT CO., (U.S. CLS. 100, 101 AND 107). SN 85-101,431. PUB. 1-18-2011. FILED 8-5-2010.
- 3,940,762. **PAINTJAM (STANDARD CHARACTER)**. DUNN, DANIEL A, (U.S. CLS. 100, 101 AND 107). SN 85-101,614. PUB. 1-18-2011. FILED 8-6-2010.
- 3,940,787. **EXHIBITORETRAK AND DESIGN**. EXHIBITOR PUBLICATIONS, INC., (U.S. CLS. 100, 101 AND 107). SN 85-102,094. PUB. 1-18-2011. FILED 8-6-2010.
- 3,940,804. **SECRET PHYSIQUE STUDIO AND DESIGN**. ANANIA, JENNIFER M, (U.S. CLS. 100, 101 AND 107). SN 85-102,394. PUB. 1-18-2011. FILED 8-6-2010.
- 3,940,818. **WICKED WORKOUTS (STANDARD CHARACTER)**. APPLETON, TAMMY, (U.S. CLS. 100, 101 AND 107). SN 85-102,517. PUB. 1-18-2011. FILED 8-7-2010.
- 3,940,819. **BIBLE BELT SINNERS (STANDARD CHARACTER)**. ERIK M KOZIEJA, (U.S. CLS. 100, 101 AND 107). SN 85-102,519. PUB. 1-18-2011. FILED 8-7-2010.
- 3,940,840. **ABSOLUTELY FOBULOUS (STANDARD CHARACTER)**. CO, EMILY, (U.S. CLS. 100, 101 AND 107). SN 85-103,310. PUB. 1-18-2011. FILED 8-9-2010.
- 3,940,854. **LOLA LOBATO (STANDARD CHARACTER)**. LOBATO, LOLA, (U.S. CLS. 100, 101 AND 107). SN 85-103,489. PUB. 1-18-2011. FILED 8-9-2010.
- 3,940,855. **THE PHINSIDER (STANDARD CHARACTER)**. SPORTSBLOGS, INC., DBA SB NATION, (U.S. CLS. 100, 101 AND 107). SN 85-103,490. PUB. 1-18-2011. FILED 8-9-

2010.  
 3,940,859. **REDISCOVER YOUR MOJO (STANDARD CHARACTER)**, MOJO ASSOCIATES, LLC, (U.S. CLS. 100, 101 AND 107). SN 85-103,586. PUB. 1-18-2011. FILED 8-9-2010.  
 3,940,861. **OPEN HEARTS FAMILY SERVICES A MINISTRY OF THE FLORIDA UNITED METHODIST CHILDREN'S HOME AND DESIGN**, FLORIDA UNITED METHODIST CHILDREN'S HOME, INC., MULTIPLE CLASS, (INT. CLS. 41 AND 45), (U.S. CLS. 100, 101 AND 107). SN 85-104,199. PUB. 1-18-2011. FILED 8-10-2010.  
 3,940,864. **GLIO-BLASTOFF 5K AND DESIGN**, KIMBALL, MEGHAN K., (U.S. CLS. 100, 101 AND 107). SN 85-105,354. PUB. 1-18-2011. FILED 8-11-2010.  
 3,940,876. **I BOOBIES! AND DESIGN**, THE KEEP A BREAST FOUNDATION, (U.S. CLS. 100, 101 AND 107). SN 85-108,727. PUB. 1-18-2011. FILED 8-16-2010.  
 3,940,880. **SOUL TUNING (STANDARD CHARACTER)**, CLARK, BARBARA A., (U.S. CLS. 100, 101 AND 107). SN 85-109,120. PUB. 1-18-2011. FILED 8-17-2010.  
 3,940,914 ( *See Class 25 for this trademark*).  
 3,940,927 ( *See Class 35 for this trademark*).  
 3,940,931. **TEXAS HOLD 'EM BONUS AND DESIGN**, SHUFFLE MASTER, INC., (U.S. CLS. 100, 101 AND 107). SN 85-126,238. PUB. 1-18-2011. FILED 9-9-2010.  
 3,940,941. **COME & GO (STANDARD CHARACTER)**, COMPASS BANCSHARES, INC., (U.S. CLS. 100, 101 AND 107). SN 85-129,109. PUB. 1-18-2011. FILED 9-14-2010.  
 3,940,943. **COME & GO EXPAND YOUR WORLD AND DESIGN**, COMPASS BANCSHARES, INC., (U.S. CLS. 100, 101 AND 107). SN 85-129,402. PUB. 1-18-2011. FILED 9-14-2010.  
 3,940,945. **TOONZAKI (STANDARD CHARACTER)**, 4KIDS ENTERTAINMENT, INC., (U.S. CLS. 100, 101 AND 107). SN 85-131,485. PUB. 1-18-2011. FILED 9-16-2010.  
 3,940,953. **REALM ENTERTAINMENT AND DESIGN**, REALM, LLC, (U.S. CLS. 100, 101 AND 107). SN 85-138,175. PUB. 1-18-2011. FILED 9-24-2010.  
 3,940,960. **FEDERATION OF DEFENSE & CORPORATE COUNSEL FDCC LITIGATION MANAGEMENT COLLEGE AND DESIGN**, FEDERATION OF DEFENSE & CORPORATE COUNSEL, INC., (U.S. CLS. 100, 101 AND 107). SN 85-143,565. PUB. 1-18-2011. FILED 10-1-2010.  
 3,940,965. **MERCK ACADEMY AND DESIGN**, MERCK SHARP & DOHME CORP., (U.S. CLS. 100, 101 AND 107). SN 85-149,460. PUB. 1-18-2011. FILED 10-11-2010.  
 3,939,505 ( *See Class 35 for this trademark*).  
 3,939,506 ( *See Class 9 for this trademark*).  
 3,939,516 ( *See Class 9 for this trademark*).  
 3,939,521 ( *See Class 35 for this trademark*).  
 3,939,522 ( *See Class 35 for this trademark*).  
 3,939,530. **VAREX SOLUTIONS (STANDARD CHARACTER)**, VAREX SOLUTIONS LLC, (U.S. CLS. 100 AND 101). SN 77-809,826. PUB. 1-18-2011. FILED 8-21-2009.  
 3,939,538 ( *See Class 35 for this trademark*).  
 3,939,541. **QUALITY AND SAFETY. DELIVERED. (STANDARD CHARACTER)**, QUALITY CERTIFICATION, LLC, (U.S. CLS. 100 AND 101). SN 77-820,804. PUB. 1-18-2011. FILED 9-4-2009.  
 3,939,558 ( *See Class 35 for this trademark*).  
 3,939,560. **MARCOMCENTRAL (STANDARD CHARACTER)**, PRINTABLE TECHNOLOGIES INC., (U.S. CLS. 100 AND 101). SN 77-849,007. PUB. 1-18-2011. FILED 10-14-2009.  
 3,939,561 ( *See Class 9 for this trademark*).  
 3,939,566. **GREEN SENSE (STANDARD CHARACTER)**, CONSTRUCTION RESEARCH & TECHNOLOGY GMBH, (U.S. CLS. 100 AND 101). SN 77-853,630. PUB. 1-18-2011. FILED 10-21-2009.  
 3,939,570 ( *See Class 37 for this trademark*).  
 3,939,571 ( *See Class 37 for this trademark*).  
 3,939,584 ( *See Class 35 for this trademark*).  
 3,939,611. **CRAZY PRAISE AND DESIGN**, SMITH, DAVID MICHAEL, DBA WORLD GOSPEL INC., (U.S. CLS. 100 AND 101). SN 77-901,656. PUB. 1-18-2011. FILED 12-28-2009.  
 3,939,620 ( *See Class 9 for this trademark*).  
 3,939,643 ( *See Class 35 for this trademark*).  
 3,939,661 ( *See Class 20 for this trademark*).  
 3,939,689. **LUNARECON (STANDARD CHARACTER)**, BITAR, PETE, (U.S. CLS. 100 AND 101). SN 77-930,194. PUB. 1-18-2011. FILED 2-8-2010.  
 3,939,693 ( *See Class 35 for this trademark*).  
 3,939,734. **SPAMLAB (STANDARD CHARACTER)**, APPRIVER, LLC, (U.S. CLS. 100 AND 101). SN 77-936,956. PUB. 1-18-2011. FILED 2-16-2010.  
 3,939,743 ( *See Class 36 for this trademark*).  
 3,939,782 ( *See Class 6 for this trademark*).  
 3,939,791. **EQUIOM (STANDARD CHARACTER)**, EQUIOM, INC., (U.S. CLS. 100 AND 101). SN 77-951,013. PUB. 1-18-2011. FILED 3-4-2010.  
 3,939,795. **BIOGAS ENERGY SYSTEMS & TECHNOLOGY LLC AND DESIGN**, BIOGAS ENERGY SYSTEMS AND TECHNOLOGY LLC, (U.S. CLS. 100 AND 101). SN 77-952,220. PUB. 1-18-2011. FILED 3-5-2010.  
 3,939,798. **MARKETPLACE365 (STANDARD CHARACTER)**, ONSTREAM MEDIA CORPORATION, (U.S. CLS. 100 AND 101). SN 77-952,741. PUB. 1-18-2011. FILED 3-8-2010.  
 3,939,801 ( *See Class 38 for this trademark*).  
 3,939,810 ( *See Class 37 for this trademark*).  
 3,939,811 ( *See Class 41 for this trademark*).  
 3,939,816 ( *See Class 36 for this trademark*).  
 3,939,852. **COMPLIANCE 360° AND DESIGN**, COMPLIANCE 360, INC., (U.S. CLS. 100 AND 101). SN 77-966,695. PUB. 1-18-2011. FILED 3-23-2010.  
 3,939,864. **ACTIVE-DUTY (STANDARD CHARACTER)**, LE SAINT COMPANIES, DBA ACTIVE-DUTY, (U.S. CLS. 100 AND 101). SN 78-399,556. PUB. 1-18-2011. FILED 4-9-2004.  
 3,939,881 ( *See Class 1 for this trademark*).  
 3,939,883 ( *See Class 28 for this trademark*).  
 3,939,890 ( *See Class 9 for this trademark*).  
 3,939,894 ( *See Class 35 for this trademark*).  
 3,939,898 ( *See Class 9 for this trademark*).  
 3,939,902 ( *See Class 35 for this trademark*).  
 3,939,909 ( *See Class 9 for this trademark*).  
 3,939,910 ( *See Class 9 for this trademark*).  
 3,939,915 ( *See Class 35 for this trademark*).  
 3,939,920 ( *See Class 9 for this trademark*).  
 3,939,921 ( *See Class 9 for this trademark*).  
 3,939,937 ( *See Class 11 for this trademark*).  
 3,939,938 ( *See Class 11 for this trademark*).  
 3,939,939 ( *See Class 9 for this trademark*).  
 3,939,940 ( *See Class 9 for this trademark*).  
 3,939,941 ( *See Class 12 for this trademark*).  
 3,939,944 ( *See Class 11 for this trademark*).  
 3,939,945 ( *See Class 11 for this trademark*).

## CLASS 42—SCIENTIFIC AND COMPUTER SERVICES

- 3,939,350 ( *See Class 37 for this trademark*).  
 3,939,354. **BIGELOW AEROSPACE (STANDARD CHARACTER)**, BIGELOW AEROSPACE, LLC, (U.S. CLS. 100 AND 101). SN 76-699,445. PUB. 1-18-2011. FILED 9-14-2009.  
 3,939,360. **LEGAL X AND DESIGN**, LITIGATION GRAPHIC TECHNOLOGY, (U.S. CLS. 100 AND 101). SN 76-700,929. PUB. 1-18-2011. FILED 12-22-2009.  
 3,939,368. **TERNSTYLE (STANDARD CHARACTER)**, PRAETZEL, PAUL, MATTHEW, (U.S. CLS. 100 AND 101). SN 76-701,915. PUB. 1-18-2011. FILED 3-5-2010.  
 3,939,374 ( *See Class 9 for this trademark*).  
 3,939,386. **BK AND DESIGN**, JAMES H. JONES., (U.S. CLS. 100 AND 101). SN 76-703,978. PUB. 1-18-2011. FILED 8-2-2010.  
 3,939,394 ( *See Class 16 for this trademark*).  
 3,939,420 ( *See Class 11 for this trademark*).  
 3,939,421 ( *See Class 9 for this trademark*).  
 3,939,422 ( *See Class 9 for this trademark*).  
 3,939,441 ( *See Class 41 for this trademark*).  
 3,939,446 ( *See Class 9 for this trademark*).  
 3,939,447 ( *See Class 9 for this trademark*).  
 3,939,448 ( *See Class 35 for this trademark*).  
 3,939,450 ( *See Class 41 for this trademark*).  
 3,939,463. **WHATSAPP (STANDARD CHARACTER)**, WHATSAPP INC., (U.S. CLS. 100 AND 101). SN 77-703,877. PUB. 1-18-2011. FILED 4-1-2009.  
 3,939,490 ( *See Class 6 for this trademark*).  
 3,939,504 ( *See Class 35 for this trademark*).



- 3,939,946 ( *See Class 11 for this trademark* ).  
3,939,951. **S SOFGEN AND DESIGN**. SOFGEN HOLDINGS LIMITED, (U.S. CLS. 100 AND 101). SN 79-079,790. PUB. 1-18-2011. FILED 12-29-2009.  
3,939,958 ( *See Class 9 for this trademark* ).  
3,939,971 ( *See Class 9 for this trademark* ).  
3,939,973 ( *See Class 35 for this trademark* ).  
3,939,976 ( *See Class 9 for this trademark* ).  
3,939,980 ( *See Class 1 for this trademark* ).  
3,939,981 ( *See Class 1 for this trademark* ).  
3,939,984. **PIONEER REEYEE AND DESIGN**. ZHOU HAI PENG, (U.S. CLS. 100 AND 101). SN 79-081,133. PUB. 1-18-2011. FILED 3-9-2010.  
3,939,990 ( *See Class 9 for this trademark* ).  
3,939,999 ( *See Class 6 for this trademark* ).  
3,940,003 ( *See Class 9 for this trademark* ).  
3,940,011 ( *See Class 7 for this trademark* ).  
3,940,030 ( *See Class 5 for this trademark* ).  
3,940,034 ( *See Class 9 for this trademark* ).  
3,940,043 ( *See Class 38 for this trademark* ).  
3,940,054 ( *See Class 11 for this trademark* ).  
3,940,059 ( *See Class 4 for this trademark* ).  
3,940,097. **REVSIGHT AND DESIGN**. METROPOLITAN CHICAGO HEALTHCARE COUNCIL, (U.S. CLS. 100 AND 101). SN 85-009,316. PUB. 1-18-2011. FILED 4-8-2010.  
3,940,118. **JITSCALE (STANDARD CHARACTER)**. IC&S, (U.S. CLS. 100 AND 101). SN 85-017,801. PUB. 1-18-2011. FILED 4-20-2010.  
3,940,125 ( *See Class 35 for this trademark* ).  
3,940,148 ( *See Class 9 for this trademark* ).  
3,940,154 ( *See Class 37 for this trademark* ).  
3,940,161 ( *See Class 35 for this trademark* ).  
3,940,174 ( *See Class 37 for this trademark* ).  
3,940,196. **RESUME (STANDARD CHARACTER)**. CELGENE CORPORATION, (U.S. CLS. 100 AND 101). SN 85-047,318. PUB. 1-18-2011. FILED 5-25-2010.  
3,940,197 ( *See Class 10 for this trademark* ).  
3,940,201 ( *See Class 9 for this trademark* ).  
3,940,202 ( *See Class 9 for this trademark* ).  
3,940,212 ( *See Class 35 for this trademark* ).  
3,940,224. **TYNET ONLINE (STANDARD CHARACTER)**. TYNET BILLING SOLUTIONS, INC, (U.S. CLS. 100 AND 101). SN 85-056,876. PUB. 1-18-2011. FILED 6-8-2010.  
3,940,234 ( *See Class 35 for this trademark* ).  
3,940,271 ( *See Class 40 for this trademark* ).  
3,940,288. **C AND DESIGN**. ENVIRONMENTAL SOLUTIONS GROUP, LLC, (U.S. CLS. 100 AND 101). SN 85-074,529. PUB. 1-18-2011. FILED 6-30-2010.  
3,940,318 ( *See Class 9 for this trademark* ).  
3,940,378. **SECURITY BEYOND PCI (STANDARD CHARACTER)**. BHI ADVANCED INTERNET, (U.S. CLS. 100 AND 101). SN 85-092,042. PUB. 1-18-2011. FILED 7-23-2010.  
3,940,390 ( *See Class 35 for this trademark* ).  
3,940,399 ( *See Class 36 for this trademark* ).  
3,940,409. **MONTANA BOTANICAL ANALYSIS AND DESIGN**. MONTANA BOTANICAL ANALYSIS LLC, (U.S. CLS. 100 AND 101). SN 85-094,589. PUB. 1-18-2011. FILED 7-28-2010.  
3,940,410 ( *See Class 41 for this trademark* ).  
3,940,414 ( *See Class 9 for this trademark* ).  
3,940,422. **OPENSCG (STANDARD CHARACTER)**. LUSSIER, DENIS, (U.S. CLS. 100 AND 101). SN 85-095,829. PUB. 1-18-2011. FILED 7-29-2010.  
3,940,442 ( *See Class 9 for this trademark* ).  
3,940,444 ( *See Class 40 for this trademark* ).  
3,940,448 ( *See Class 41 for this trademark* ).  
3,940,455. **REMOTE SUPPORT MADE EASY (STANDARD CHARACTER)**. CITRIX ONLINE LLC, (U.S. CLS. 100 AND 101). SN 85-097,185. PUB. 1-18-2011. FILED 7-30-2010.  
3,940,469. **JOINGO AND DESIGN**. JOINGO, (U.S. CLS. 100 AND 101). SN 85-097,404. PUB. 1-18-2011. FILED 7-30-2010.  
3,940,498. **OPENMENU AND DESIGN**. OPEN MENU, (U.S. CLS. 100 AND 101). SN 85-097,699. PUB. 1-18-2011. FILED 8-1-2010.  
3,940,525 ( *See Class 35 for this trademark* ).  
3,940,541 ( *See Class 41 for this trademark* ).  
3,940,545. **NOWCHOOSE (STANDARD CHARACTER)**. PRE-LIGHT DAY PRODUCTIONS, INC., (U.S. CLS. 100 AND 101). SN 85-098,519. PUB. 1-18-2011. FILED 8-2-2010.  
3,940,570 ( *See Class 38 for this trademark* ).  
3,940,583. **SECURITY BEGINS WITH TRUST (STANDARD CHARACTER)**. TRUSTWAVE HOLDINGS, INC., (U.S. CLS. 100 AND 101). SN 85-099,170. PUB. 1-18-2011. FILED 8-3-2010.  
3,940,589. **EVERYPENNY (STANDARD CHARACTER)**. NEUDESIC, LLC, (U.S. CLS. 100 AND 101). SN 85-099,314. PUB. 1-18-2011. FILED 8-3-2010.  
3,940,593. **SYLOGENT (STANDARD CHARACTER)**. SYLOGENT LLC, (U.S. CLS. 100 AND 101). SN 85-099,362. PUB. 1-18-2011. FILED 8-3-2010.  
3,940,638. **DESIGN FOR SAFETY APPROVALS - DFSA (STANDARD CHARACTER)**. PRODUCT SAFETY CONSULTING, INC., (U.S. CLS. 100 AND 101). SN 85-100,037. PUB. 1-18-2011. FILED 8-4-2010.  
3,940,641. **LEADSIGHT (STANDARD CHARACTER)**. WEBPROLEADS LLC, DBA WEBPROLEADS, (U.S. CLS. 100 AND 101). SN 85-100,091. PUB. 1-18-2011. FILED 8-4-2010.  
3,940,649. **SAFETY BEYOND STANDARDS - SBS (STANDARD CHARACTER)**. PRODUCT SAFETY CONSULTING, INC., (U.S. CLS. 100 AND 101). SN 85-100,161. PUB. 1-18-2011. FILED 8-4-2010.  
3,940,666. **PEOPLES MART (STYLIZED)**. INFLECTION LLC, (U.S. CLS. 100 AND 101). SN 85-100,371. PUB. 1-18-2011. FILED 8-4-2010.  
3,940,674. **EHRIGHT (STANDARD CHARACTER)**. ENCORE HEALTH RESOURCES, (U.S. CLS. 100 AND 101). SN 85-100,471. PUB. 1-18-2011. FILED 8-4-2010.  
3,940,685 ( *See Class 38 for this trademark* ).  
3,940,686. **GOTOASSIST PRO (STANDARD CHARACTER)**. CITRIX ONLINE LLC, (U.S. CLS. 100 AND 101). SN 85-100,642. PUB. 1-18-2011. FILED 8-5-2010.  
3,940,697. **TAP INTO OUR BRAIN POWER (STANDARD CHARACTER)**. THE JONES GROUP APC, (U.S. CLS. 100 AND 101). SN 85-100,782. PUB. 1-18-2011. FILED 8-5-2010.  
3,940,725. **ULTRAMATICS (STANDARD CHARACTER)**. ULTRAMATICS, INC., (U.S. CLS. 100 AND 101). SN 85-101,141. PUB. 1-18-2011. FILED 8-5-2010.  
3,940,737. **FDG (STYLIZED)**. FISCHER DESIGN GROUP, LLC, (U.S. CLS. 100 AND 101). SN 85-101,326. PUB. 1-18-2011. FILED 8-5-2010.  
3,940,756. **COMMUNITEACH (STANDARD CHARACTER)**. COMMUNITEACH LLC, (U.S. CLS. 100 AND 101). SN 85-101,552. PUB. 1-18-2011. FILED 8-5-2010.  
3,940,771 ( *See Class 11 for this trademark* ).  
3,940,773. **AGREE'NSIGN (STANDARD CHARACTER)**. HEADSPIN SOFTWARE, LLC, (U.S. CLS. 100 AND 101). SN 85-101,930. PUB. 1-18-2011. FILED 8-6-2010.  
3,940,786. **MY YEAR IN STATUS (STANDARD CHARACTER)**. EXPERION, INC., DBA SOCIAL GRAPH STUDIOS, (U.S. CLS. 100 AND 101). SN 85-102,074. PUB. 1-18-2011. FILED 8-6-2010.  
3,940,798 ( *See Class 9 for this trademark* ).  
3,940,799. **STUDIOSML (STANDARD CHARACTER)**. STUDIOSML, LLC, (U.S. CLS. 100 AND 101). SN 85-102,313. PUB. 1-18-2011. FILED 8-6-2010.  
3,940,807. **4 FS4USA BE THE MASTER OF YOUR DOMAIN AND DESIGN**. FS4USA, (U.S. CLS. 100 AND 101). SN 85-102,429. PUB. 1-18-2011. FILED 8-6-2010.  
3,940,822 ( *See Class 35 for this trademark* ).  
3,940,863. **MY YEAR IN PHOTOS (STANDARD CHARACTER)**. EXPERION, INC., DBA SOCIAL GRAPH STUDIOS, (U.S. CLS. 100 AND 101). SN 85-105,342. PUB. 1-18-2011. FILED 8-11-2010.  
3,940,869 ( *See Class 35 for this trademark* ).  
3,940,879 ( *See Class 38 for this trademark* ).  
3,940,883. **TRUSTKEEPER (STANDARD CHARACTER)**. TRUSTWAVE HOLDINGS, INC., (U.S. CLS. 100 AND 101). SN 85-110,211. PUB. 1-18-2011. FILED 8-18-2010.  
3,940,895. **WAKE FOREST UNIVERSITY AND DESIGN**. WAKE FOREST UNIVERSITY, (U.S. CLS. 100 AND 101). SN 85-112,422. PUB. 1-18-2011. FILED 8-20-2010.  
3,940,924 ( *See Class 35 for this trademark* ).  
3,940,975. **SIOS (STANDARD CHARACTER)**. SIOS TECHNOLOGY, INC., (U.S. CLS. 100 AND 101). SN 85-975,109. PUB. 11-9-2010. FILED 4-30-2010.

**CLASS 43—HOTEL AND RESTAURANT SERVICES**

- 3,939,353. **SUITES OF AMERICA (STANDARD CHARACTER)**. BIGELOW MANAGEMENT, INC., (U.S. CLS. 100 AND 101). SN 76-699,442. PUB. 1-18-2011. FILED 9-14-2009.
- 3,939,357. **SUITES OF AMERICA (STANDARD CHARACTER)**. BIGELOW MANAGEMENT, INC., (U.S. CLS. 100 AND 101). SN 76-699,641. PUB. 1-18-2011. FILED 9-25-2009.
- 3,939,376. **WILD THYME'S WELLNESS AND DESIGN**. PFOODMAN HOLDINGS, L.L.C., (U.S. CLS. 100 AND 101). SN 76-703,055. PUB. 1-18-2011. FILED 5-21-2010.
- 3,939,388. **EUROPA CAFÉ AND DESIGN**. PAX INTELLECTUAL PROPERTY HOLDINGS, INC., (U.S. CLS. 100 AND 101). SN 76-704,149. PUB. 1-18-2011. FILED 8-18-2010.
- 3,939,399. **THE MATADOR (STANDARD CHARACTER)**. MO-CORE, LLC, (U.S. CLS. 100 AND 101). SN 77-232,526. PUB. 1-18-2011. FILED 7-18-2007.
- 3,939,426 ( *See Class 32 for this trademark*).
- 3,939,434. **FIESTA MEXICANA RESTAURANTS AND DESIGN**. FIESTA MEXICANA RESTAURANTS, (U.S. CLS. 100 AND 101). SN 77-586,586. PUB. 1-18-2011. FILED 10-6-2008.
- 3,939,439. **SHERLOCK'S PUB CO. (STANDARD CHARACTER)**. HOSPITALITY USA HOLDINGS, LLC, (U.S. CLS. 100 AND 101). SN 77-613,515. PUB. 1-18-2011. FILED 11-13-2008.
- 3,939,456. **PUSH THE BUTTON (STANDARD CHARACTER)**. FOUR STAR DRIVE-IN RESTAURANTS, L.P., (U.S. CLS. 100 AND 101). SN 77-683,241. PUB. 1-18-2011. FILED 3-4-2009.
- 3,939,499. **SUGARLAND (STANDARD CHARACTER)**. SUGARLAND LLC, (U.S. CLS. 100 AND 101). SN 77-779,522. PUB. 1-18-2011. FILED 7-13-2009.
- 3,939,533. **MISTER TACO AND DESIGN**. RUBANOWITZ, INC., (U.S. CLS. 100 AND 101). SN 77-810,896. PUB. 1-18-2011. FILED 8-24-2009.
- 3,939,567 ( *See Class 24 for this trademark*).
- 3,939,606 ( *See Class 36 for this trademark*).
- 3,939,648 ( *See Class 21 for this trademark*).
- 3,939,718. **CUORE DELL AMANTE (STANDARD CHARACTER)**. DIMITROV, VLADIMIRE, (U.S. CLS. 100 AND 101). SN 77-935,989. PUB. 1-18-2011. FILED 2-15-2010.
- 3,939,775 ( *See Class 41 for this trademark*).
- 3,939,821. **ROOTSTOCK (STANDARD CHARACTER)**. ROOT-STOCK WINE & BEER BAR LLC, (U.S. CLS. 100 AND 101). SN 77-959,708. PUB. 1-18-2011. FILED 3-16-2010.
- 3,939,901 ( *See Class 35 for this trademark*).
- 3,939,922 ( *See Class 14 for this trademark*).
- 3,939,923 ( *See Class 36 for this trademark*).
- 3,939,967 ( *See Class 25 for this trademark*).
- 3,940,026 ( *See Class 14 for this trademark*).
- 3,940,186. **SMITHFIELD'S CHICKEN 'N BAR-B-Q (STANDARD CHARACTER)**. SF INVESTMENTS, INC., (U.S. CLS. 100 AND 101). SN 85-045,202. PUB. 1-18-2011. FILED 5-21-2010.
- 3,940,187. **SMITHFIELD'S CHICKEN 'N BAR-B-Q (STYLIZED)**. SF INVESTMENTS, INC., (U.S. CLS. 100 AND 101). SN 85-045,205. PUB. 1-18-2011. FILED 5-21-2010.
- 3,940,244. **FAZ RESTAURANTS & CATERING (STANDARD CHARACTER)**. FAZ RESTAURANT, INC., (U.S. CLS. 100 AND 101). SN 85-062,375. PUB. 1-18-2011. FILED 6-14-2010.
- 3,940,259. **LEMON BAR (STANDARD CHARACTER)**. JAST PARTNERS, LLC, (U.S. CLS. 100 AND 101). SN 85-065,802. PUB. 1-18-2011. FILED 6-17-2010.
- 3,940,312. **DENTON'S (STANDARD CHARACTER)**. DENTON ENTERPRISES, INC., (U.S. CLS. 100 AND 101). SN 85-081,293. PUB. 1-18-2011. FILED 7-9-2010.
- 3,940,391. **SKYLINE TENT COMPANY AND DESIGN**. SKYLINE TENT COMPANY, (U.S. CLS. 100 AND 101). SN 85-093,563. PUB. 1-18-2011. FILED 7-27-2010.
- 3,940,413. **ZEB'S BACKYARD GRILL (STANDARD CHARACTER)**. NEW ZANGO, (U.S. CLS. 100 AND 101). SN 85-095,243. PUB. 1-18-2011. FILED 7-28-2010.
- 3,940,537. **GRAFFITI JUNKTION AND DESIGN**. GRAFFITI JUNKTION LLC, (U.S. CLS. 100 AND 101). SN 85-098,414. PUB. 1-18-2011. FILED 8-2-2010.
- 3,940,566 ( *See Class 39 for this trademark*).
- 3,940,578. **MAS PIZZA. MENOS DINERO. (STANDARD**

- CHARACTER)**. PIZZA PATRON, INC., (U.S. CLS. 100 AND 101). SN 85-099,027. PUB. 1-18-2011. FILED 8-3-2010.
- 3,940,620 ( *See Class 25 for this trademark*).
- 3,940,621 ( *See Class 25 for this trademark*).
- 3,940,631. **YCHOP (STANDARD CHARACTER)**. YNOT LLC, (U.S. CLS. 100 AND 101). SN 85-099,961. PUB. 1-18-2011. FILED 8-4-2010.
- 3,940,661 ( *See Class 41 for this trademark*).
- 3,940,698 ( *See Class 30 for this trademark*).
- 3,940,704. **MISCELLANEOUS DESIGN**. MICHAEL K. LONG, (U.S. CLS. 100 AND 101). SN 85-100,888. PUB. 1-18-2011. FILED 8-5-2010.
- 3,940,729. **EVELYN'S KITCHEN (STANDARD CHARACTER)**. EVELYN'S KITCHEN, INC., (U.S. CLS. 100 AND 101). SN 85-101,250. PUB. 1-18-2011. FILED 8-5-2010.
- 3,940,763. **THE QUEEN VIC (STANDARD CHARACTER)**. QUEEN VIC, LLC, DBA THE QUEEN VIC, (U.S. CLS. 100 AND 101). SN 85-101,652. PUB. 1-18-2011. FILED 8-6-2010.
- 3,940,768. **PIEPERS AND DESIGN**. PIEPERS ENTERPRISES, INC., (U.S. CLS. 100 AND 101). SN 85-101,803. PUB. 1-18-2011. FILED 8-6-2010.
- 3,940,803. **MARKET BROILER (STANDARD CHARACTER)**. PREFERRED HOSPITALITY, INC., FORMERLY MARKET BROILER MANAGEMENT, INC., (U.S. CLS. 100 AND 101). SN 85-102,356. PUB. 1-18-2011. FILED 8-6-2010.
- 3,940,842. **BARKWELLS (STANDARD CHARACTER)**. DIVA PROPERTIES, INC., DBA BARKWELLS, (U.S. CLS. 100 AND 101). SN 85-103,377. PUB. 1-18-2011. FILED 8-9-2010.
- 3,940,906 ( *See Class 32 for this trademark*).
- 3,940,926. **PAT'S HUBBA HUBBA (STANDARD CHARACTER)**. MPC COVE ROAD RESTAURANT, INC., (U.S. CLS. 100 AND 101). SN 85-122,464. PUB. 1-18-2011. FILED 9-3-2010.

**CLASS 44—MEDICAL, BEAUTY AND AGRICULTURAL SERVICES**

- 3,939,369. **RESILIENCE BUILDER PROGRAM (STYLIZED)**. ALVORD, BAKER & ASSOCIATES, LLC, (U.S. CLS. 100 AND 101). SN 76-702,225. PUB. 1-18-2011. FILED 3-25-2010.
- 3,939,394 ( *See Class 16 for this trademark*).
- 3,939,426 ( *See Class 32 for this trademark*).
- 3,939,433 ( *See Class 9 for this trademark*).
- 3,939,443 ( *See Class 35 for this trademark*).
- 3,939,444 ( *See Class 35 for this trademark*).
- 3,939,445 ( *See Class 35 for this trademark*).
- 3,939,461 ( *See Class 3 for this trademark*).
- 3,939,481 ( *See Class 5 for this trademark*).
- 3,939,497 ( *See Class 36 for this trademark*).
- 3,939,498 ( *See Class 36 for this trademark*).
- 3,939,503 ( *See Class 41 for this trademark*).
- 3,939,508. **JANSSEN SUPPORT ONE AND DESIGN**. JOHNSON & JOHNSON, (U.S. CLS. 100 AND 101). SN 77-787,607. PUB. 1-18-2011. FILED 7-23-2009.
- 3,939,572. **FLU SHOTS FOR YOU - ON SITE EVERYWHERE (STANDARD CHARACTER)**. STEINBERG, JOSEPHINE, (U.S. CLS. 100 AND 101). SN 77-861,801. PUB. 12-14-2010. FILED 10-30-2009.
- 3,939,573. **FLU SHOTS 4 U - ON SITE EVERYWHERE (STANDARD CHARACTER)**. STEINBERG, JOSEPHINE, (U.S. CLS. 100 AND 101). SN 77-861,832. PUB. 12-14-2010. FILED 10-30-2009.
- 3,939,580 ( *See Class 41 for this trademark*).
- 3,939,589. **VITATREE (STANDARD CHARACTER)**. R&J NUTRACEUTICALS INC., (U.S. CLS. 100 AND 101). SN 77-879,904. PUB. 1-18-2011. FILED 11-24-2009.
- 3,939,595 ( *See Class 41 for this trademark*).
- 3,939,677. **CHIT-CHAT FARMS (STANDARD CHARACTER)**. RICHARD J. CARON FOUNDATION, (U.S. CLS. 100 AND 101). SN 77-928,526. PUB. 1-18-2011. FILED 2-4-2010.
- 3,939,729. **DMC CARDIOVASCULAR INSTITUTE AND DESIGN**. DETROIT MEDICAL CENTER, AKA DMC, (U.S. CLS. 100 AND 101). SN 77-936,602. PUB. 1-18-2011. FILED 2-16-2010.
- 3,939,771. **BEAUTY YOU CAN TRUST (STANDARD CHARACTER)**. ZAEGA, INC., (U.S. CLS. 100 AND 101). SN 77-

945,883. PUB. 1-18-2011. FILED 2-26-2010.  
 3,939,811 ( *See Class 41 for this trademark* ).  
 3,939,835. **CORE DIET AND DESIGN**. QT2 SYSTEMS, (U.S. CLS. 100 AND 101). SN 77-963,923. PUB. 1-18-2011. FILED 3-19-2010.  
 3,939,963 ( *See Class 5 for this trademark* ).  
 3,940,036. **F.M. MEDIDENT DENTAL X-RAY INSTITUTE COMPUTERISED CEPH. TRACING & ANALYSIS AND DESIGN**. SC FM MEDIDENT SRL, (U.S. CLS. 100 AND 101). SN 79-084,793. PUB. 1-18-2011. FILED 6-24-2010.  
 3,940,042 ( *See Class 3 for this trademark* ).  
 3,940,079 ( *See Class 35 for this trademark* ).  
 3,940,082. **AMERICAN SOCIETY OF OPHTHALMIC PLASTIC & RECONSTRUCTIVE SURGERY (STANDARD CHARACTER)**. AMERICAN SOCIETY OF OPHTHALMIC PLASTIC & RECONSTRUCTIVE SURGERY, INC., (U.S. CLS. 100 AND 101). SN 85-002,257. PUB. 1-18-2011. FILED 3-30-2010.  
 3,940,141. **DESTINATION HEALTHCARE (STANDARD CHARACTER)**. CHINA CONNECTION, INC., (U.S. CLS. 100 AND 101). SN 85-029,964. PUB. 10-12-2010. FILED 5-4-2010.  
 3,940,232. **RESTORE SELECT (STANDARD CHARACTER)**. IMAGYN IP, LLC, (U.S. CLS. 100 AND 101). SN 85-058,329. PUB. 1-18-2011. FILED 6-9-2010.  
 3,940,292. **BHRS WRAP AROUND EFFECTIVE TREATMENT ... IN A WRAPAROUND CUP AND DESIGN**. KOSSOR, STEVEN, (U.S. CLS. 100 AND 101). SN 85-076,045. PUB. 1-18-2011. FILED 7-1-2010.  
 3,940,333. **DZUGAN METHOD (STANDARD CHARACTER)**. FOUNTAIN ANTI-AGING LLC, (U.S. CLS. 100 AND 101). SN 85-085,225. PUB. 1-18-2011. FILED 7-15-2010.  
 3,940,364. **LIVE LIFE LIGHTER AND DESIGN**. KUANG, GORDON, (U.S. CLS. 100 AND 101). SN 85-090,283. PUB. 1-18-2011. FILED 7-22-2010.  
 3,940,367. **CLINICALLY ENHANCED TPA (STANDARD CHARACTER)**. CORRECTIONAL HEALTH PARTNERS, (U.S. CLS. 100 AND 101). SN 85-090,631. PUB. 1-18-2011. FILED 7-22-2010.  
 3,940,402. **DEVIL MOUNTAIN WHOLESALE NURSERY AND DESIGN**. DEVIL MOUNTAIN WHOLESALE NURSERY, INC., (U.S. CLS. 100 AND 101). SN 85-094,290. PUB. 1-18-2011. FILED 7-27-2010.  
 3,940,466. **THE BRANCH AND DESIGN**. LONG, DEREK, (U.S. CLS. 100 AND 101). SN 85-097,351. PUB. 1-18-2011. FILED 7-30-2010.  
 3,940,505. **STILL YOU. PERFECTED. (STANDARD CHARACTER)**. SPA PACE LLC, (U.S. CLS. 100 AND 101). SN 85-097,793. PUB. 1-18-2011. FILED 8-2-2010.  
 3,940,516. **ENRICHING THE LIVES OF ALL THOSE WE TOUCH (STANDARD CHARACTER)**. MORAVIAN HALL SQUARE OF NAZARETH, PA, INC., DBA MORAVIAN HALL SQUARE, (U.S. CLS. 100 AND 101). SN 85-098,032. PUB. 1-18-2011. FILED 8-2-2010.  
 3,940,622 ( *See Class 35 for this trademark* ).  
 3,940,637. **MISCELLANEOUS DESIGN**. DENTAL LOGIC, LLC, (U.S. CLS. 100 AND 101). SN 85-100,031. PUB. 1-18-2011. FILED 8-4-2010.  
 3,940,642. **LIFECORD CORD BLOOD BANK AND DESIGN**. LIFESOUTH COMMUNITY BLOOD CENTERS, (U.S. CLS. 100 AND 101). SN 85-100,098. PUB. 1-18-2011. FILED 8-4-2010.  
 3,940,660. **"IT'S ALL ABOUT THE PEOPLE" (STANDARD CHARACTER)**. NEUSCHELER, MICHAEL, (U.S. CLS. 100 AND 101). SN 85-100,319. PUB. 1-18-2011. FILED 8-4-2010.  
 3,940,661 ( *See Class 41 for this trademark* ).  
 3,940,669. **OPTIMAL HEARING AND DESIGN**. OPTIMAL HEARING SYSTEMS, INC, (U.S. CLS. 100 AND 101). SN 85-100,440. PUB. 1-18-2011. FILED 8-4-2010.  
 3,940,692. **IT'S ALL ABOUT THE PEOPLE (STANDARD CHARACTER)**. NEUSCHELER, MICHAEL, (U.S. CLS. 100 AND 101). SN 85-100,744. PUB. 1-18-2011. FILED 8-5-2010.  
 3,940,705 ( *See Class 41 for this trademark* ).  
 3,940,707 ( *See Class 35 for this trademark* ).  
 3,940,709. **MYSPECTRUM (STANDARD CHARACTER)**. SPECTRUM HEALTH SYSTEM, (U.S. CLS. 100 AND 101). SN 85-100,938. PUB. 1-18-2011. FILED 8-5-2010.  
 3,940,722. **PACIFIC SMILES (STANDARD CHARACTER)**

FRED J. KIM DDS, INC., (U.S. CLS. 100 AND 101). SN 85-101,048. PUB. 1-18-2011. FILED 8-5-2010.  
 3,940,726 ( *See Class 35 for this trademark* ).  
 3,940,735. **HOOCHICOOCHI (STANDARD CHARACTER)**. HOOCHI COOCHI WAX STUDIO, INC., (U.S. CLS. 100 AND 101). SN 85-101,305. PUB. 1-18-2011. FILED 8-5-2010.  
 3,940,748. **BULWARK BULLMASTIFFS AND DESIGN**. HOERLE, DAWNA M., (U.S. CLS. 100 AND 101). SN 85-101,488. PUB. 1-18-2011. FILED 8-5-2010.  
 3,940,754. **MISCELLANEOUS DESIGN**. MCDONALDS SANITATION SERVICES LLC, (U.S. CLS. 100 AND 101). SN 85-101,527. PUB. 1-18-2011. FILED 8-5-2010.  
 3,940,772. **DR. DAVID SUTTIE DENTISTRY FOR CHILDREN AND DESIGN**. DAVID SUTTIE, AND ROSANNE SUTTIE, (U.S. CLS. 100 AND 101). SN 85-101,891. PUB. 1-18-2011. FILED 8-6-2010.  
 3,940,824. **DRARUTT.COM (STANDARD CHARACTER)**. ARUTT, CHERYL A, DBA CHERYL ARUTT, PSY.D., (U.S. CLS. 100 AND 101). SN 85-102,558. PUB. 1-18-2011. FILED 8-7-2010.  
 3,940,889. **CHEFS CORPS (STANDARD CHARACTER)**. I-DEV INTERNATIONAL, (U.S. CLS. 100 AND 101). SN 85-110,800. PUB. 1-18-2011. FILED 8-18-2010.  
 3,940,936. **WAKE FOREST UNIVERSITY AND DESIGN**. WAKE FOREST UNIVERSITY, (U.S. CLS. 100 AND 101). SN 85-128,138. PUB. 1-18-2011. FILED 9-13-2010.  
 3,940,955. **PAUSE...THE SPA AND DESIGN**. EXHALE INC., (U.S. CLS. 100 AND 101). SN 85-138,851. PUB. 1-18-2011. FILED 9-27-2010.  
 3,940,963. **GREENER IS (STANDARD CHARACTER)**. TRU-GREEN LIMITED PARTNERSHIP, (U.S. CLS. 100 AND 101). SN 85-148,415. PUB. 1-18-2011. FILED 10-8-2010.

---

#### CLASS 45—PERSONAL AND LEGAL SERVICES

3,939,356. **LAW29 A PROFESSIONAL CORPORATION "LAW I CAN AFFORD" AND DESIGN**. LAW29 A PROFESSIONAL CORPORATION, (U.S. CLS. 100 AND 101). SN 76-699,601. PUB. 1-18-2011. FILED 9-23-2009.  
 3,939,417 ( *See Class 14 for this trademark* ).  
 3,939,431 ( *See Class 35 for this trademark* ).  
 3,939,432 ( *See Class 35 for this trademark* ).  
 3,939,443 ( *See Class 35 for this trademark* ).  
 3,939,444 ( *See Class 35 for this trademark* ).  
 3,939,445 ( *See Class 35 for this trademark* ).  
 3,939,497 ( *See Class 36 for this trademark* ).  
 3,939,498 ( *See Class 36 for this trademark* ).  
 3,939,549. **IN TOUCH MINISTRIES (STANDARD CHARACTER)**. IN TOUCH MINISTRIES, INC., (U.S. CLS. 100 AND 101). SN 77-837,101. PUB. 1-18-2011. FILED 9-29-2009.  
 3,939,550. **IN TOUCH (STANDARD CHARACTER)**. IN TOUCH MINISTRIES, INC., (U.S. CLS. 100 AND 101). SN 77-837,170. PUB. 1-18-2011. FILED 9-29-2009.  
 3,939,606 ( *See Class 36 for this trademark* ).  
 3,939,659 ( *See Class 41 for this trademark* ).  
 3,939,664. **CHANGEMAKERS (STANDARD CHARACTER)**. ASHOKA: INNOVATORS FOR THE PUBLIC, (U.S. CLS. 100 AND 101). SN 77-924,085. PUB. 1-18-2011. FILED 1-29-2010.  
 3,939,685. **HOMECARE CONSULTANTS UNLIMITED, INC. AND DESIGN**. HOMECARE CONSULTANTS UNLIMITED, INC., (U.S. CLS. 100 AND 101). SN 77-929,387. PUB. 1-18-2011. FILED 2-5-2010.  
 3,939,694. **DOTVEGAS (STANDARD CHARACTER)**. DOT VEGAS, INC., (U.S. CLS. 100 AND 101). SN 77-930,927. PUB. 1-18-2011. FILED 2-8-2010.  
 3,939,730 ( *See Class 16 for this trademark* ).  
 3,939,807. **JBR AND DESIGN**. JBR ENVIRONMENTAL CONSULTANTS, INC., (U.S. CLS. 100 AND 101). SN 77-955,997. PUB. 1-18-2011. FILED 3-10-2010.  
 3,939,810 ( *See Class 37 for this trademark* ).  
 3,939,813 ( *See Class 35 for this trademark* ).  
 3,939,837. **GREENWICH LEGAL (STANDARD CHARACTER)**. LACOFF, BRANDON, (U.S. CLS. 100 AND 101). SN 77-964,346. PUB. 1-18-2011. FILED 3-21-2010.

- 3,939,849. **CARE CONNECTIONS INC. EXPERTS IN NAN-NIES, CHILDCARE, AND PARENTING SOLUTIONS AND DESIGN.** CARE CONNECTIONS, INC., (U.S. CLS. 100 AND 101). SN 77-965,763. PUB. 1-18-2011. FILED 3-23-2010.
- 3,939,890 ( *See Class 9 for this trademark*).
- 3,939,910 ( *See Class 9 for this trademark*).
- 3,939,931 ( *See Class 14 for this trademark*).
- 3,939,980 ( *See Class 1 for this trademark*).
- 3,939,999 ( *See Class 6 for this trademark*).
- 3,940,095. **SPIRITUAL NOVICE (STANDARD CHARACTER).** DE GRENIER, KAREN, (U.S. CLS. 100 AND 101). SN 85-007,836. PUB. 1-18-2011. FILED 4-6-2010.
- 3,940,150. **HOROSCOPE COM AND DESIGN.** HOROSCOPE.-COM, INC., (U.S. CLS. 100 AND 101). SN 85-032,957. PUB. 1-18-2011. FILED 5-7-2010.
- 3,940,174 ( *See Class 37 for this trademark*).
- 3,940,253. **LL LEYLEGAL.COM LAW FOR ALL. AND DESIGN.** LEYLEGAL, LLC, (U.S. CLS. 100 AND 101). SN 85-064,845. PUB. 1-18-2011. FILED 6-16-2010.
- 3,940,295. **CANEM WORLD CELEBRATE THE PASSION AND DESIGN.** CANEM WORLD, INC., (U.S. CLS. 100 AND 101). SN 85-077,345. PUB. 1-18-2011. FILED 7-2-2010.
- 3,940,320. **MY ESQ. (STANDARD CHARACTER).** INTERNATIONAL LEGAL AND BUSINESS SERVICES GROUP, (U.S. CLS. 100 AND 101). SN 85-082,832. PUB. 1-18-2011. FILED 7-12-2010.
- 3,940,332. **GIBNOW (STANDARD CHARACTER).** EWING, LYNN A., DBA GIBNOW.COM, (U.S. CLS. 100 AND 101). SN 85-084,756. PUB. 1-18-2011. FILED 7-14-2010.
- 3,940,372 ( *See Class 35 for this trademark*).
- 3,940,373 ( *See Class 35 for this trademark*).
- 3,940,374 ( *See Class 35 for this trademark*).
- 3,940,462. **THE WORLD PROTECTION GROUP (STANDARD CHARACTER).** THE WORLD PROTECTION GROUP, INC., (U.S. CLS. 100 AND 101). SN 85-097,315. PUB. 1-18-2011. FILED 7-30-2010.
- 3,940,513. **RESTORE (COMMUNITY CHURCH) AND DESIGN.** RESTORE COMMUNITY CHURCH, (U.S. CLS. 100 AND 101). SN 85-097,967. PUB. 1-18-2011. FILED 8-2-2010.
- 3,940,514. **R-GUARD (STANDARD CHARACTER).** REMPRESX, LLC, (U.S. CLS. 100 AND 101). SN 85-097,994. PUB. 1-18-2011. FILED 8-2-2010.
- 3,940,543 ( *See Class 35 for this trademark*).
- 3,940,547 ( *See Class 35 for this trademark*).
- 3,940,627. **ENFACT (STANDARD CHARACTER).** FISERV, INC., (U.S. CLS. 100 AND 101). SN 85-099,928. PUB. 1-18-2011. FILED 8-4-2010.
- 3,940,628. **INFACT (STANDARD CHARACTER).** FISERV, INC., (U.S. CLS. 100 AND 101). SN 85-099,936. PUB. 1-18-2011. FILED 8-4-2010.
- 3,940,646 ( *See Class 36 for this trademark*).
- 3,940,648. **LIFELINK (STANDARD CHARACTER).** LIFELINK CORPORATION, (U.S. CLS. 100 AND 101). SN 85-100,158. PUB. 1-18-2011. FILED 8-4-2010.
- 3,940,652 ( *See Class 36 for this trademark*).
- 3,940,703. **JOCKSTAT (STANDARD CHARACTER).** GREGORY GOLDSAND, AND JOSH BRADLEY, (U.S. CLS. 100 AND 101). SN 85-100,844. PUB. 1-18-2011. FILED 8-5-2010.
- 3,940,712. **GOT JUSTICE! (STANDARD CHARACTER).** KMIEC LAW OFFICES, S.C., (U.S. CLS. 100 AND 101). SN 85-100,976. PUB. 1-18-2011. FILED 8-5-2010.
- 3,940,733. **MOLONEY FAMILY FUNERAL HOMES, INC. (STANDARD CHARACTER).** MOLONEY FAMILY FUNERAL HOMES, INC., (U.S. CLS. 100 AND 101). SN 85-101,291. PUB. 1-18-2011. FILED 8-5-2010.
- 3,940,817. **1-800-DEFENSE (STANDARD CHARACTER).** FEST-FARE, INC, (U.S. CLS. 100 AND 101). SN 85-102,515. PUB. 1-18-2011. FILED 8-7-2010.
- 3,940,821. **THE LOVE MAVEN (STANDARD CHARACTER).** ROSENBAUM, SUE, (U.S. CLS. 100 AND 101). SN 85-102,542. PUB. 1-18-2011. FILED 8-7-2010.
- 3,940,830. **SPANATIX (STANDARD CHARACTER).** SPANATIX, INC., (U.S. CLS. 100 AND 101). SN 85-102,654. PUB. 1-18-2011. FILED 8-8-2010.
- 3,940,831. **ADDICTED TO SPORTS (STANDARD CHARACTER).** SPANATIX, INC., (U.S. CLS. 100 AND 101). SN 85-102,656. PUB. 1-18-2011. FILED 8-8-2010.
- 3,940,844. **TRANSFORMATION GARDEN (STANDARD CHARACTER).** TRANSFORMATION GARDEN, INC., (U.S. CLS. 100 AND 101). SN 85-103,421. PUB. 1-18-2011. FILED 8-9-2010.
- 3,940,852. **CULTURE BUMP (STANDARD CHARACTER).** ARCHER, CAROL M., (U.S. CLS. 100 AND 101). SN 85-103,477. PUB. 1-18-2011. FILED 8-9-2010.
- 3,940,861 ( *See Class 41 for this trademark*).
- 3,940,878. **AMERICAN DEFENSE LAWYERS AND DESIGN.** AMERICAN DEFENSE LAWYERS, PC, (U.S. CLS. 100 AND 101). SN 85-109,027. PUB. 1-18-2011. FILED 8-17-2010.

\* \* \* \* \*

SECTION 2.—PRIOR UNITED STATES CLASSIFICATION

COLLECTIVE MEMBERSHIP MARKS

**CLASS 200—COLLECTIVE MEMBERSHIP**

3,939,659 (*See Class 41 for this trademark.*)

---

CERTIFICATION MARKS

CLASS A—GOODS

3,939,375. **BACL AND DESIGN.** BAY AREA COMPLIANCE LABORATORIES CORP., SN 76-702,965. PUB. 1-18-2011. FILED 5-17-2010.

3,939,382. **OMRI PRODUCTS AVAILABLE LISTED AND DESIGN.** ORGANIC MATERIALS REVIEW INSTITUTE, SN 76-703,815. PUB. 1-18-2011. FILED 7-19-2010.

CLASS B—SERVICES

3,939,681. **CERTIFIED LACTATION COUNSELOR (STANDARD CHARACTER).** HEALTHY CHILDREN PROJECT, INC., DBA ACADEMY OF LACTATION POLICY AND PRACTICE, INC., SN 77-928,930. PUB. 1-18-2011. FILED 2-5-2010.

3,939,699. **CAHIIM ACCREDITED PROGRAM AND DESIGN.** AMERICAN HEALTH INFORMATION MANAGEMENT ASSOCIATION, SN 77-932,022. PUB. 1-18-2011. FILED 2-9-2010.

3,939,738. **BIGGER. BOLDER. BETTER (STANDARD CHARACTER).** GIANT SCREEN CINEMA ASSOCIATION, INC., SN 77-938,132. PUB. 1-18-2011. FILED 2-17-2010.

\* \* \* \* \*

# TRADEMARK REGISTRATIONS ISSUED UNDER SECTION 1(d)

The following marks have registered on the Principal Register pursuant to the intent-to-use provisions of Section 1(d) of the Trademark Act of 1946, as amended.

## SECTION 1.— INTERNATIONAL CLASSIFICATION

The short titles associated below with the international class numbers are terms designed merely for quick identification and are not an official part of the international classification. The full names of international classes are given in section 6.1 of the trademark rules of practice.

The designation "U.S. Cl." appearing in this section refers to the U.S. class in effect prior to Sep. 1, 1973 rather than the international class which applies to applications filed on or after that date. For adoption of international classification see notice in the OFFICIAL GAZETTE of Jun. 26, 1973 (911 O.G. TM 210).

### Application in more than one class

3,940,977. DIAGEO IRELAND, DUBLIN 8, IRELAND. SN 76-067,276. PUB. 4-3-2007, FILED 6-9-2000.

**GUINNESS**

OWNER OF U.S. REG. NOS. 321,014, 1,182,992, AND OTHERS.  
SEC. 2(F).

#### CLASS 6—METAL GOODS

FOR GOODS MADE OF COMMON METALS, NAMELY, KEY RINGS AND COASTERS; NON-LUMINOUS AND NON-MECHANICAL METAL SIGNS; METAL COASTERS (U.S. CLS. 2, 12, 13, 14, 23, 25 AND 50).  
FIRST USE 1-0-2005; IN COMMERCE 1-0-2005.

#### CLASS 20—FURNITURE AND ARTICLES NOT OTHERWISE CLASSIFIED

FOR FURNITURE MIRRORS (U.S. CLS. 2, 13, 22, 25, 32 AND 50).  
FIRST USE 12-0-2006; IN COMMERCE 12-0-2006.

#### CLASS 41—EDUCATION AND ENTERTAINMENT

FOR EDUCATIONAL SERVICES, NAMELY, PROVIDING CLASSES, SEMINARS AND WORKSHOPS IN THE FIELDS OF MUSIC, SPORTS, MOVIES AND TELEVISION ENTERTAINMENT, RECREATIONAL AND LEISURE ACTIVITIES, AND TOPICS RELATED TO BEVERAGE ALCOHOL; ENTERTAINMENT SERVICES, NAMELY, ORGANIZING AND PROVIDING FACILITIES FOR SPORTS AND MUSICAL EVENTS; ORGANIZING, PRODUCING, CONDUCTING, AND PRESENTING LIVE EVENTS AND EXHIBITIONS, NAMELY, MUSICAL AND THEATRICAL PERFORMANCES AND SPORTS COMPETITIONS; AND ORGANIZING COMMUNITY SPORTING AND CULTURAL EVENTS (U.S. CLS. 100, 101 AND 107).  
FIRST USE 0-0-2001; IN COMMERCE 0-0-2001.

#### CLASS 42—SCIENTIFIC AND COMPUTER SERVICES

FOR COMPUTER SERVICES, NAMELY, PROVIDING ON-LINE NEWSLETTERS IN THE FIELDS OF MUSIC, SPORTS, MOVIES AND TELEVISION ENTERTAINMENT, RECREATIONAL AND LEISURE ACTIVITIES, AND TOPICS RELATED TO BEVERAGE ALCOHOL (U.S. CLS. 100 AND 101).  
FIRST USE 0-0-2001; IN COMMERCE 0-0-2001.

3,940,982. BLUFIN S.P.A., CARPI, ITALY. SN 76-673,791. PUB. 12-11-2007, FILED 3-8-2007.

**BLUGIRL FOLIES**

THE MARK CONSISTS OF STANDARD CHARACTERS WITHOUT CLAIM TO ANY PARTICULAR FONT, STYLE, SIZE, OR COLOR.  
OWNER OF U.S. REG. NO. 2,070,473.

#### CLASS 18—LEATHER GOODS

FOR LEATHER AND IMITATIONS OF LEATHER; GOODS MADE OF THESE MATERIALS INCLUDED IN THIS CLASS, NAMELY, LEATHER PURSES, LEATHER KEY CHAINS, LEATHER SHOPPING BAGS, LEATHER SOLD IN BULK; ANIMAL SKINS, HIDES; TRUNKS, TRAVELLING BAGS, KNAPSACKS AND TRAVELLING ARTICLES INCLUDED IN THIS CLASS, NAMELY, BILLFOLDS; BAGS, NAMELY, HANDBAGS, SHOULDER BAGS, POUCHES OF LEATHER; BEAUTY BAGS, BEAUTY CASES AND VANITY CASES SOLD EMPTY; WALLETS, KEY-CASES, CHANGE-PURSES; UMBRELLAS, PARASOLS AND WALKING STICKS; SADDLERY (U.S. CLS. 1, 2, 3, 22 AND 41).  
FIRST USE 1-1-2008; IN COMMERCE 6-30-2010.

#### CLASS 25—CLOTHING

FOR ARTICLES OF CLOTHING, NAMELY, UNDERWEAR, JEANS, SWIMSUITS, FOOTWEAR, HEADWEAR; SPORTSWEAR, NAMELY, SPORT JERSEYS, SPORT COATS, SPORT SHIRTS, WINDPROOF JACKETS AND SWIMMING ATTIRE (U.S. CLS. 22 AND 39).  
FIRST USE 1-1-2008; IN COMMERCE 6-30-2010.

3,940,984. GOCH, MARKUS, 30167 HANNOVER, FED REP GERMANY. SN 76-678,551. PUB. 12-23-2008, FILED 6-21-2007.

## EASYDISPLAY

THE MARK CONSISTS OF STANDARD CHARACTERS WITHOUT CLAIM TO ANY PARTICULAR FONT, STYLE, SIZE, OR COLOR.

### CLASS 6—METAL GOODS

FOR METAL GOODS, NAMELY, SUGGESTION BOXES, BALLOT BOXES, FUNDRAISING CHARITY DONATION BOXES, CONTEST BOXES; PIPES AND TUBES OF METAL (U.S. CLS. 2, 12, 13, 14, 23, 25 AND 50).

FIRST USE 4-0-2002; IN COMMERCE 5-0-2008.

### CLASS 20—FURNITURE AND ARTICLES NOT OTHERWISE CLASSIFIED

FOR PORTABLE TRADESHOW COUNTERS AND DISPLAYS, NAMELY, DISPLAY RACKS, DISPLAY CASES, DISPLAY STANDS, DISPLAY COUNTERS, AND DISPLAY BOOTHS; PORTABLE BANNER DISPLAYS, NAMELY, DISPLAY RACKS, DISPLAY CASES, DISPLAY STANDS, DISPLAY COUNTERS, AND DISPLAY BOOTHS; TRADE SHOW DISPLAYS, NAMELY, DISPLAY RACKS, DISPLAY CASES, DISPLAY STANDS, DISPLAY COUNTERS, AND DISPLAY BOOTHS; METAL GOODS, NAMELY, FREE-STANDING AND WALL MOUNTED PICTURE FRAMES, POSTER FRAMES, DISPLAY STANDS, WIRE RACKS, CLOTHING RACKS, SHELVING UNITS, SALES COUNTERS, DISPLAY CASES, SHOWCASES, PODIUMS, LECTERNS, CHURCH PULPITS, MAGAZINES RACKS, MAGAZINE HOLDERS, LITERATURE RACKS, BULLETIN BOARDS AND BANNER STANDS (U.S. CLS. 2, 13, 22, 25, 32 AND 50).

FIRST USE 4-0-2002; IN COMMERCE 5-0-2008.

3,940,989. AMERINET, INC., ST. LOUIS, MO. SN 76-697,029. PUB. 5-4-2010, FILED 4-22-2009.

## NAVIGATE TRENDPOINT

THE MARK CONSISTS OF STANDARD CHARACTERS WITHOUT CLAIM TO ANY PARTICULAR FONT, STYLE, SIZE, OR COLOR.

### CLASS 35—ADVERTISING AND BUSINESS

FOR SERVICES PROVIDED TO MEMBER HOSPITALS, CLINICS, HEALTH CARE CENTERS, PHARMACIES, NURSING HOMES AND MEDICAL INSTITUTIONS, NAMELY, BUSINESS MANAGEMENT CONSULTATION SERVICES WITH RELATION TO STRATEGY, FEATURING ANALYTIC MODELS FOR UNDERSTANDING AND PREDICTING OF MARKET TRENDS, AND DEMOGRAPHIC CONSULTATION AND STUDIES PERTAINING TO HEALTHCARE PATIENTS (U.S. CLS. 100, 101 AND 102).

FIRST USE 4-0-2009; IN COMMERCE 4-0-2009.

### CLASS 44—MEDICAL, BEAUTY AND AGRICULTURAL SERVICES

FOR PROVIDING HEALTHCARE INFORMATION TO MEMBERS OF A GROUP PURCHASING ORGANIZATION INCLUDING HOSPITALS, CLINICS, HEALTH CARE CENTERS, PHARMACIES, NURSING HOMES AND MEDICAL INSTITUTIONS CONCERNING HEALTHCARE PRODUCT USAGE AND HEALTHCARE SERVICES (U.S. CLS. 100 AND 101).

FIRST USE 4-0-2009; IN COMMERCE 4-0-2009.

3,940,996. SUCCESS IN MARKETING, LLC, OCALA, FL. SN 76-700,678. PUB. 5-18-2010, FILED 12-4-2009.

## SUCCESS IN MARKETING

THE MARK CONSISTS OF STANDARD CHARACTERS WITHOUT CLAIM TO ANY PARTICULAR FONT, STYLE, SIZE, OR COLOR.

NO CLAIM IS MADE TO THE EXCLUSIVE RIGHT TO USE "MARKETING", APART FROM THE MARK AS SHOWN.

### CLASS 35—ADVERTISING AND BUSINESS

FOR PROVIDING ADVERTISING, PROMOTIONAL AND MARKETING SERVICES, NAMELY, DEVELOPMENT OF MARKETING CAMPAIGNS USING PROMOTIONAL AND BRANDED PRODUCTS (U.S. CLS. 100, 101 AND 102).

FIRST USE 11-1-2009; IN COMMERCE 1-3-2011.

### CLASS 42—SCIENTIFIC AND COMPUTER SERVICES

FOR PROVIDING WEBSITE DEVELOPMENT SERVICES FOR OTHERS; PROVIDING COMPUTER SERVICES, NAMELY, SEARCH ENGINE OPTIMIZATION SERVICES (U.S. CLS. 100 AND 101).

FIRST USE 11-1-2009; IN COMMERCE 1-3-2011.

3,941,001. GROUP PUBLISHING, INC., LOVELAND, CO. SN 76-701,340. PUB. 6-15-2010, FILED 1-25-2010.

## FUN FOR THE WHOLE FAMILY HOUR

THE MARK CONSISTS OF STANDARD CHARACTERS WITHOUT CLAIM TO ANY PARTICULAR FONT, STYLE, SIZE, OR COLOR.

NO CLAIM IS MADE TO THE EXCLUSIVE RIGHT TO USE "HOUR", APART FROM THE MARK AS SHOWN.

### CLASS 9—ELECTRICAL AND SCIENTIFIC APPARATUS

FOR AUDIO RECORDINGS AND VIDEO RECORDINGS ALL FEATURING CHRISTIAN EDUCATIONAL AND INSTRUCTIONAL INFORMATION WITH PRINTED TEACHING MATERIALS FOR EDUCATIONAL ACTIVITIES IN CONNECTION THEREWITH SOLD AS A UNIT TO BE USED IN CHURCHES AND OTHER CHRISTIAN EDUCATIONAL SETTINGS; AND AUDIO RECORDINGS AND VIDEO RECORDINGS SOLD SEPARATELY ALL FEATURING CHRISTIAN EDUCATIONAL INFORMATION AND INSTRUCTIONAL INFORMATION TO BE USED IN CHURCHES AND OTHER CHRISTIAN EDUCATIONAL SETTINGS (U.S. CLS. 21, 23, 26, 36 AND 38).

FIRST USE 11-1-2009; IN COMMERCE 11-1-2009.

**CLASS 16—PAPER GOODS AND PRINTED MATTER**

FOR PRINTED PUBLICATIONS, NAMELY, GUIDES AND PRINTED TEACHING MATERIALS FOR EDUCATIONAL ACTIVITIES SOLD SEPARATELY OR WITHIN A MINISTRY KIT ALL FEATURING CHRISTIAN EDUCATIONAL AND INSTRUCTIONAL INFORMATION TO BE USED IN CHURCHES AND OTHER CHRISTIAN EDUCATIONAL SETTINGS (U.S. CLS. 2, 5, 22, 23, 29, 37, 38 AND 50).

FIRST USE 11-1-2009; IN COMMERCE 11-1-2009.

3,941,013. COOL CYCLES ICE CREAM CO. LLC, TACOMA, WA. SN 77-056,608. PUB. 11-20-2007, FILED 12-4-2006.



NO CLAIM IS MADE TO THE EXCLUSIVE RIGHT TO USE "CO." AS TO INTERNATIONAL CLASSES 16 AND 25, AND "CYCLES" AND "ICE CREAM CO." AS TO INTERNATIONAL CLASSES 35, 36 AND 39, APART FROM THE MARK AS SHOWN.

THE MARK CONSISTS OF A SABER TOOTH CAT-LIKE FIGURE WEARING SUNGLASSES AND A NECK SCARF AND HOLDING UP ARMS WITH THUMBS UP, ABOVE WHICH APPEARS THE WORDS "COOL CYCLES" AND BELOW WHICH APPEARS THE WORDING "ICE CREAM CO."

**CLASS 16—PAPER GOODS AND PRINTED MATTER**

FOR TEMPORARY TATTOOS AND STICKERS (U.S. CLS. 2, 5, 22, 23, 29, 37, 38 AND 50).

FIRST USE 12-31-2008; IN COMMERCE 3-31-2010.

**CLASS 25—CLOTHING**

FOR CLOTHING, NAMELY, T-SHIRTS, KNIT SHIRTS, SHIRTS, SWEATERS, SWEATSHIRTS, JACKETS, VESTS, COVERALLS, RAINWEAR, PANTS, SHORTS, SCARVES; HEADGEAR, NAMELY, CAPS, HATS, VISORS, HEADBANDS; WRISTBANDS, BELTS AND GLOVES (U.S. CLS. 22 AND 39).

FIRST USE 12-31-2008; IN COMMERCE 3-31-2010.

**CLASS 35—ADVERTISING AND BUSINESS**

FOR RETAIL MOBILE VENDING SERVICES FEATURING ICE CREAM AND FROZEN CONFECTIONS; VENDING MACHINE SERVICES FEATURING ICE CREAM AND FROZEN CONFECTIONS; WHOLESALE DISTRIBUTORSHIPS FEATURING ICE CREAM AND FROZEN CONFECTIONS; ONLINE RETAIL STORE AND ONLINE WHOLESALE STORE SERVICES FEATURING ICE CREAM AND FROZEN CONFECTIONS; FRANCHISING, NAMELY, OFFERING TECHNICAL AND BUSINESS MANAGEMENT ASSISTANCE IN THE ESTABLISHMENT AND/OR OPERATION OF BUSINESSES THAT PROVIDE RETAIL MOBILE VENDING SERVICES AND VENDING MACHINE SERVICES FEATURING ICE CREAM AND FROZEN CONFECTIONS; RETAIL SERVICES BY DIRECT SOLICITATION BY SALES AGENTS IN THE FIELD OF MOTORCYCLES, SIDECARS AND REFRIGERATED TRAILERS WHICH ARE USED IN CONNECTION WITH THE SALE OF ICE CREAM AND FROZEN CONFECTIONS; LEASING OF VENDING EQUIPMENT, NAMELY, FREEZERS, VENDING MACHINES AND CARTS WHICH ARE USED IN CONNECTION WITH THE SALE OF ICE CREAM AND FROZEN CONFECTIONS (U.S. CLS. 100, 101 AND 102).

FIRST USE 12-31-2008; IN COMMERCE 3-31-2010.

**CLASS 36—INSURANCE AND FINANCIAL**

FOR FINANCING SERVICES RELATED TO THE SALES OR LEASING OF MOTORCYCLES, SIDECARS, TRAILERS AND VENDING EQUIPMENT WHICH ARE USED IN CONNECTION WITH THE SALE OF ICE CREAM AND FROZEN CONFECTIONS; CHARITABLE FUNDRAISING SERVICES (U.S. CLS. 100, 101 AND 102).

FIRST USE 12-31-2008; IN COMMERCE 6-30-2010.

**CLASS 39—TRANSPORTATION AND STORAGE**

FOR LEASING OF MOTORCYCLES, SIDECARS, AND REFRIGERATED TRAILERS WHICH ARE USED IN CONNECTION WITH THE SALE OF ICE CREAM AND FROZEN CONFECTIONS (U.S. CLS. 100 AND 105).

FIRST USE 12-31-2008; IN COMMERCE 6-30-2010.

3,941,020. RAYNOR CANADA CORP., MISSISSAUGA, CANADA. SN 77-101,710. PUB. 4-15-2008, FILED 2-7-2007.

**FAMILY SAFE**

THE MARK CONSISTS OF STANDARD CHARACTERS WITHOUT CLAIM TO ANY PARTICULAR FONT, STYLE, SIZE, OR COLOR.

PRIORITY CLAIMED UNDER SEC. 44(D) ON CANADA APPLICATION NO. 1319848, FILED 10-4-2006, REG. NO. TMA700367, DATED 11-6-2007, EXPIRES 11-6-2022.

**CLASS 6—METAL GOODS**

FOR METAL GARAGE DOORS, AND METAL COMPONENTS THEREFOR; FINGER-PROTECTED METAL SECTIONAL GARAGE DOORS (U.S. CLS. 2, 12, 13, 14, 23, 25 AND 50).

FIRST USE 3-31-2005; IN COMMERCE 3-31-2005.



**CLASS 19—NON-METALLIC BUILDING MATERIALS**

FOR NON-METAL GARAGE DOORS AND NON-METAL COMPONENTS THEREFORE; NON-METAL SECTIONAL GARAGE DOORS (U.S. CLS. 1, 12, 33 AND 50).  
FIRST USE 3-31-2005; IN COMMERCE 3-31-2005.

---

3,941,027. NEXTOY, LLC, CHAPPAQUA, NY. SN 77-195,266.  
PUB. 12-18-2007, FILED 6-1-2007.

**KENKEN**

THE MARK CONSISTS OF STANDARD CHARACTERS WITHOUT CLAIM TO ANY PARTICULAR FONT, STYLE, SIZE, OR COLOR.

**CLASS 9—ELECTRICAL AND SCIENTIFIC APPARATUS**

FOR DOWNLOADABLE GAMES AND PUZZLES VIA WIRELESS DEVICES; ELECTRONIC GAME PROGRAMS; ELECTRONIC GAME SOFTWARE FOR CELLULAR TELEPHONES; ELECTRONIC GAME SOFTWARE FOR HANDHELD ELECTRONIC DEVICES; ELECTRONIC GAME SOFTWARE FOR WIRELESS DEVICES; GAME SOFTWARE; INTERACTIVE MULTIMEDIA COMPUTER GAME PROGRAM; COMPUTER APPLICATION SOFTWARE FOR MOBILE PHONES, ALL IN THE FIELD OF GAMES AND PUZZLES (U.S. CLS. 21, 23, 26, 36 AND 38).

FIRST USE 5-0-2009; IN COMMERCE 5-0-2009.

**CLASS 16—PAPER GOODS AND PRINTED MATTER**

FOR CHILDREN'S ACTIVITY BOOKS; CHILDREN'S BOOKS, ALL IN THE FIELD OF GAMES AND PUZZLES (U.S. CLS. 2, 5, 22, 23, 29, 37, 38 AND 50).  
FIRST USE 10-0-2008; IN COMMERCE 10-0-2008.

**CLASS 41—EDUCATION AND ENTERTAINMENT**

FOR ENTERTAINMENT SERVICES, NAMELY, PROVIDING AN ON-LINE COMPUTER GAME; ENTERTAINMENT SERVICES, NAMELY, PROVIDING ON-LINE COMPUTER GAMES; PROVIDING A COMPUTER GAME THAT MAY BE ACCESSED NETWORK-WIDE BY NETWORK USERS; MULTIMEDIA PUBLISHING OF GAMES, ALL IN THE FIELD OF GAMES AND PUZZLES (U.S. CLS. 100, 101 AND 107).

FIRST USE 1-15-2009; IN COMMERCE 1-15-2009.

---

3,941,029. JAMES DE GIVENCHY, INC., NEW YORK, NY.  
SN 77-204,658. PUB. 11-20-2007, FILED 6-13-2007.

**TAFFIN**

THE MARK CONSISTS OF STANDARD CHARACTERS WITHOUT CLAIM TO ANY PARTICULAR FONT, STYLE, SIZE, OR COLOR.

OWNER OF U.S. REG. NOS. 2,494,322 AND 2,613,198.

**CLASS 16—PAPER GOODS AND PRINTED MATTER**

FOR NOTE PADS (U.S. CLS. 2, 5, 22, 23, 29, 37, 38 AND 50).  
FIRST USE 12-6-2002; IN COMMERCE 12-6-2002.

**CLASS 18—LEATHER GOODS**

FOR WALLET(S) (U.S. CLS. 1, 2, 3, 22 AND 41).  
FIRST USE 1-17-2008; IN COMMERCE 1-17-2008.

---

3,941,031. MATTRESS FIRM, INC., HOUSTON, TX. SN 77-216,757. PUB. 1-13-2009, FILED 6-27-2007.

**MATTRESS FIRM**

THE COLOR(S) RED, YELLOW AND BLACK IS/ARE CLAIMED AS A FEATURE OF THE MARK.

THE MARK CONSISTS OF "MATTRESS FIRM" IN RED AND A YELLOW AND BLACK SWOOSH DESIGN UNDERNEATH "FIRM".

**CLASS 16—PAPER GOODS AND PRINTED MATTER**

FOR PRINTED PUBLICATIONS, NAMELY, NEWSLETTERS, BROCHURES, AND WRITTEN EDUCATIONAL MATERIALS REGARDING SLEEP AND SLEEPING DISORDERS (U.S. CLS. 2, 5, 22, 23, 29, 37, 38 AND 50).

FIRST USE 10-4-2009; IN COMMERCE 10-4-2009.

**CLASS 35—ADVERTISING AND BUSINESS**

FOR RETAIL STORE SERVICES FEATURING FURNITURE, BEDS, MATTRESSES, MATTRESS FRAMES, MATTRESS FOUNDATIONS, BOX SPRINGS, MATTRESS COVERS, MATTRESS PADS, MATTRESS TOPPERS AND SLEEP-RELATED PRODUCTS (U.S. CLS. 100, 101 AND 102).

FIRST USE 6-0-2003; IN COMMERCE 6-0-2003.

**CLASS 44—MEDICAL, BEAUTY AND AGRICULTURAL SERVICES**

FOR PROVIDING INFORMATION ABOUT SLEEP DISORDERS AND SLEEP ISSUES RELATING TO HEALTH (U.S. CLS. 100 AND 101).

FIRST USE 10-4-2009; IN COMMERCE 10-4-2009.

---

3,941,044. BRIDGEWATER SYSTEMS CORPORATION, OTTAWA, ONTARIO, CANADA. SN 77-284,125. PUB. 6-3-2008, FILED 9-20-2007.

**bridgewater  
SYSTEMS**

OWNER OF U.S. REG. NOS. 2,464,790 AND 2,468,663.

NO CLAIM IS MADE TO THE EXCLUSIVE RIGHT TO USE "SYSTEMS", APART FROM THE MARK AS SHOWN.

THE MARK CONSISTS OF THE WORDING "BRIDGEWATER SYSTEMS" AND A DESIGN ELEMENT CREATED BY TWO OVERLAPPING CURVED BANDS, LOCATED TO THE RIGHT OF THE LITERAL ELEMENT.

#### **CLASS 9—ELECTRICAL AND SCIENTIFIC APPARATUS**

FOR COMPUTER AND COMMUNICATIONS HARDWARE FOR USE IN THE CARRIAGE, DELIVERY, CONTROL, MONITORING AND MANAGEMENT OF DATA, VOICE, IMAGES AND VIDEO TRANSMISSIONS OVER COMMUNICATIONS NETWORKS (U.S. CLS. 21, 23, 26, 36 AND 38).

FIRST USE 7-2-2008; IN COMMERCE 7-2-2008.

#### **CLASS 37—CONSTRUCTION AND REPAIR**

FOR REPAIR AND INSTALLATION FOR OTHERS OF COMPUTER AND COMMUNICATIONS HARDWARE AND SYSTEMS (U.S. CLS. 100, 103 AND 106).

FIRST USE 6-18-2005; IN COMMERCE 6-18-2005.

#### **CLASS 42—SCIENTIFIC AND COMPUTER SERVICES**

FOR CONSULTING AND CUSTOM DESIGN SERVICES FOR OTHERS IN THE FIELD OF COMPUTER AND COMMUNICATIONS HARDWARE AND SYSTEMS; AND PROVIDING TECHNICAL SUPPORT AND SYSTEMS SOFTWARE AND HARDWARE ARCHITECTURE, DESIGN, IMPLEMENTATION AND DEPLOYMENT INFORMATION ABOUT COMMUNICATIONS NETWORKS AND COMMUNICATIONS NETWORK PRODUCTS VIA A GLOBAL COMPUTER NETWORK (U.S. CLS. 100 AND 101).

FIRST USE 6-18-2005; IN COMMERCE 6-18-2005.

---

3,941,045. BRIDGEWATER SYSTEMS CORPORATION, OTTAWA, CANADA. SN 77-284,129. PUB. 6-3-2008, FILED 9-20-2007.

### **BRIDGEWATER SYSTEMS**

THE MARK CONSISTS OF STANDARD CHARACTERS WITHOUT CLAIM TO ANY PARTICULAR FONT, STYLE, SIZE, OR COLOR.

OWNER OF U.S. REG. NOS. 2,464,790 AND 2,468,663.

NO CLAIM IS MADE TO THE EXCLUSIVE RIGHT TO USE "SYSTEMS", APART FROM THE MARK AS SHOWN.

#### **CLASS 9—ELECTRICAL AND SCIENTIFIC APPARATUS**

FOR COMPUTER AND COMMUNICATIONS HARDWARE FOR USE IN THE CARRIAGE, DELIVERY, CONTROL, MONITORING AND MANAGEMENT OF DATA, VOICE, IMAGES AND VIDEO TRANSMISSIONS OVER COMMUNICATIONS NETWORKS (U.S. CLS. 21, 23, 26, 36 AND 38).

FIRST USE 7-2-2008; IN COMMERCE 7-2-2008.

#### **CLASS 37—CONSTRUCTION AND REPAIR**

FOR REPAIR AND INSTALLATION FOR OTHERS OF COMPUTER AND COMMUNICATIONS HARDWARE AND SYSTEMS (U.S. CLS. 100, 103 AND 106).

FIRST USE 6-18-2005; IN COMMERCE 6-18-2005.

#### **CLASS 42—SCIENTIFIC AND COMPUTER SERVICES**

FOR CONSULTING AND CUSTOM DESIGN SERVICES FOR OTHERS IN THE FIELD OF COMPUTER AND COMMUNICATIONS HARDWARE AND SYSTEMS; AND PROVIDING TECHNICAL SUPPORT AND SYSTEMS SOFTWARE AND HARDWARE ARCHITECTURE, DESIGN, IMPLEMENTATION AND DEPLOYMENT INFORMATION ABOUT COMMUNICATIONS NETWORKS AND COMMUNICATIONS NETWORK PRODUCTS VIA A GLOBAL COMPUTER NETWORK (U.S. CLS. 100 AND 101).

FIRST USE 6-18-2005; IN COMMERCE 6-18-2005.

---

3,941,049. FTI CONSULTING, INC., ANNAPOLIS, MD. SN 77-310,769. PUB. 10-14-2008, FILED 10-23-2007.

### **FTI CONSULTING**

THE MARK CONSISTS OF STANDARD CHARACTERS WITHOUT CLAIM TO ANY PARTICULAR FONT, STYLE, SIZE, OR COLOR.

OWNER OF U.S. REG. NOS. 1,415,368 AND 2,779,050.

NO CLAIM IS MADE TO THE EXCLUSIVE RIGHT TO USE "CONSULTING", APART FROM THE MARK AS SHOWN.

#### **CLASS 35—ADVERTISING AND BUSINESS**

FOR TEMPORARY AND INTERIM BUSINESS MANAGEMENT SERVICES; BUSINESS CONSULTATION IN THE AREAS OF DOCUMENT INFORMATION EXCHANGE; MANAGEMENT OF COMPUTERIZED FILES AND DOCUMENTS VIA INTRANETS, EXTRANETS, INTERNETS AND OTHER PUBLIC AND PRIVATE NETWORKS; OUTSOURCING IN THE FIELD OF DATA MODELING AND DATA ANALYTICS; CONSULTATION IN THE FIELDS OF MARKETING AND CORPORATE STRATEGY; ECONOMIC ANALYSIS IN CONNECTION WITH ACQUISITIONS, MERGERS AND BUSINESS STRATEGY; COMPUTERIZED DATABASE MANAGEMENT (U.S. CLS. 100, 101 AND 102).

FIRST USE 6-30-1998; IN COMMERCE 6-30-1998.

#### **CLASS 36—INSURANCE AND FINANCIAL**

FOR INVESTMENT BANKING SERVICES; FINANCIAL ANALYSIS AND CONSULTATION; BUSINESS AND INVESTMENT SECURITY VALUATIONS (U.S. CLS. 100, 101 AND 102).

FIRST USE 11-28-2003; IN COMMERCE 11-28-2003.

#### **CLASS 42—SCIENTIFIC AND COMPUTER SERVICES**

FOR ENGINEERING CONSULTATION, SCIENTIFIC CONSULTATION IN THE FIELDS OF FORENSIC SCIENCE, SCIENTIFIC RESEARCH; COMPUTER PROGRAMMING, COMPUTER SOFTWARE DESIGN AND CONSULTATION IN THE FIELD OF COMPUTER SOFTWARE (U.S. CLS. 100 AND 101).

FIRST USE 6-8-1998; IN COMMERCE 6-8-1998.

#### **CLASS 45—PERSONAL AND LEGAL SERVICES**

FOR LITIGATION CONSULTING; COMPUTER ASSISTED LITIGATION SUPPORT (U.S. CLS. 100 AND 101).

FIRST USE 6-8-1998; IN COMMERCE 6-8-1998.

3,941,050. NATIONAL LOGISTICS MANAGEMENT CO., DETROIT, MI. SN 77-314,416. PUB. 5-6-2008, FILED 10-26-2007.



OWNER OF U.S. REG. NO. 3,058,207.  
THE MARK CONSISTS OF A GLOBE WITH ARROWS SURROUNDING A HORIZONTAL LINE CONTAINING THE LETTERS "NLM".

#### CLASS 35—ADVERTISING AND BUSINESS

FOR TRANSPORTATION LOGISTICS SERVICES, NAMELY, ARRANGING THE TRANSPORTATION OF GOODS FOR OTHERS; TRANSPORTATION LOGISTICS SERVICES, NAMELY, PLANNING AND SCHEDULING SHIPMENTS FOR USERS OF TRANSPORTATION SERVICES (U.S. CLS. 100, 101 AND 102).

FIRST USE 10-26-2007; IN COMMERCE 10-26-2007.

#### CLASS 42—SCIENTIFIC AND COMPUTER SERVICES

FOR PROVIDING TEMPORARY USE OF NON-DOWNLOADABLE COMPUTER SOFTWARE FOR SHIPMENT PROCESSING OVER COMPUTER NETWORKS, INTRANETS AND THE INTERNET; PROVIDING TEMPORARY USE OF NON-DOWNLOADABLE COMPUTER SOFTWARE FOR TRACKING FREIGHT OVER COMPUTER NETWORKS, INTRANETS AND THE INTERNET; PROVIDING ON-LINE NON-DOWNLOADABLE SOFTWARE FOR USE IN THE FIELD OF TRANSPORTATION LOGISTICS OR SUPPLY CHAIN MANAGEMENT; AND PROVIDING ONLINE NON-DOWNLOADABLE SOFTWARE FOR USE IN ENABLING SHIPPERS, CARRIERS, AND BROKERS TO COMMUNICATE AND CONDUCT BUSINESS (U.S. CLS. 100 AND 101).

FIRST USE 10-26-2007; IN COMMERCE 10-26-2007.

3,941,051. 1C JOINT STOCK VENTURE, MOSCOW, RUSSIAN FED.. SN 77-316,017. PUB. 4-15-2008, FILED 10-29-2007.

NECROVISION

THE MARK CONSISTS OF STANDARD CHARACTERS WITHOUT CLAIM TO ANY PARTICULAR FONT, STYLE, SIZE, OR COLOR.

#### CLASS 9—ELECTRICAL AND SCIENTIFIC APPARATUS

FOR COMPUTER GAME PROGRAMS, VIDEO GAME CARTRIDGES; DOWNLOADABLE ELECTRONIC PUBLICATIONS, NAMELY, MAGAZINES AND NEWSLETTERS ABOUT COMPUTER GAMES AND VIDEO GAMES DEALING WITH MILITARY COMBAT (U.S. CLS. 21, 23, 26, 36 AND 38).

FIRST USE 5-18-2009; IN COMMERCE 5-18-2009.

#### CLASS 16—PAPER GOODS AND PRINTED MATTER

FOR PRINTED PUBLICATIONS, NAMELY, PRINTED MANUALS WITH INSTRUCTIONS FOR PLAYING AND USING COMPUTER GAME PROGRAMS, VIDEO GAME PROGRAMS AND VIDEO GAME MACHINES (U.S. CLS. 2, 5, 22, 23, 29, 37, 38 AND 50).

FIRST USE 5-18-2009; IN COMMERCE 5-18-2009.

3,941,052. 1C JOINT STOCK VENTURE, MOSCOW, RUSSIAN FED.. SN 77-316,041. PUB. 4-15-2008, FILED 10-29-2007.



THE MARK CONSISTS OF A STYLIZED WORD "NECROVISION".

#### CLASS 9—ELECTRICAL AND SCIENTIFIC APPARATUS

FOR COMPUTER GAME PROGRAMS, VIDEO GAME CARTRIDGES; DOWNLOADABLE ELECTRONIC PUBLICATIONS, NAMELY, MAGAZINES AND NEWSLETTERS ABOUT COMPUTER GAMES AND VIDEO GAMES DEALING WITH MILITARY COMBAT (U.S. CLS. 21, 23, 26, 36 AND 38).

FIRST USE 5-18-2009; IN COMMERCE 5-18-2009.

#### CLASS 16—PAPER GOODS AND PRINTED MATTER

FOR PRINTED PUBLICATIONS, NAMELY, PRINTED MANUALS WITH INSTRUCTIONS FOR PLAYING AND USING COMPUTER GAME PROGRAMS, VIDEO GAME PROGRAMS AND VIDEO GAME MACHINES (U.S. CLS. 2, 5, 22, 23, 29, 37, 38 AND 50).

FIRST USE 5-18-2009; IN COMMERCE 5-18-2009.

3,941,070. D & P CUSTOM LIGHTS & WIRING SYSTEMS, INC., NASHVILLE, TN. SN 77-423,241. PUB. 4-28-2009, FILED 3-16-2008.

D&P CUSTOM LIGHTS & WIRING SYSTEMS, INC.

THE MARK CONSISTS OF STANDARD CHARACTERS WITHOUT CLAIM TO ANY PARTICULAR FONT, STYLE, SIZE, OR COLOR.

NO CLAIM IS MADE TO THE EXCLUSIVE RIGHT TO USE "CUSTOM LIGHTS & WIRING SYSTEMS, INC.", APART FROM THE MARK AS SHOWN.

**CLASS 9—ELECTRICAL AND SCIENTIFIC APPARATUS**

FOR POWER POLES, BLANK POWER POLES, AND PRE-WIRED POWER POLES, ALL OF METAL USED AS WIRE WAYS; ELECTRICAL MODULAR EXTENDER CABLES; ELECTRICAL MODULAR CONNECTORS; ELECTRICAL POWER CHANNELS AND ELECTRICAL POWER BOXES USED AS WIRE WAYS OR WIRED TO HOUSE ELECTRIC OUTLETS; BACKLIT INTERIOR SIGNS; BACKLIT SIGN BOXES; DIRECTIONAL AND INFORMATIONAL MARKERS, NAMELY, BACKLIT, ELECTRIC AND LUMINOUS SIGNS IN THE NATURE OF AISLE MARKERS (U.S. CLS. 21, 23, 26, 36 AND 38).  
FIRST USE 2-22-2008; IN COMMERCE 2-22-2008.

3,941,076. ISAACS, DAVID, BROOKLYN, NY. SN 77-431,666. PUB. 8-5-2008, FILED 3-26-2008.

**CLASS 11—ENVIRONMENTAL CONTROL APPARATUS**

FOR CHECKOUT LIGHTS AND CHECKOUT SHADES FOR POWER POLES IN THE NATURE OF LIGHT FIXTURES FOR INDICATING THE OPEN OR CLOSED STATUS OF A RETAIL CHECKOUT LANE (U.S. CLS. 13, 21, 23, 31 AND 34).  
FIRST USE 2-22-2008; IN COMMERCE 2-22-2008.

HI-HELLO THE FLYING TURTLE

THE MARK CONSISTS OF STANDARD CHARACTERS WITHOUT CLAIM TO ANY PARTICULAR FONT, STYLE, SIZE, OR COLOR.

3,941,073. BERTONI, ITALO, WINDSOR, CANADA. SN 77-428,004. PUB. 10-27-2009, FILED 3-21-2008.

CLEARDECK

**CLASS 16—PAPER GOODS AND PRINTED MATTER**

FOR CHILDREN'S BOOKS; CHILDREN'S ACTIVITY BOOKS; COLORING BOOKS; COMIC BOOKS; TALKING CHILDREN'S BOOKS; TRAVEL BOOKS; SERIES OF FICTION BOOKS; SONG BOOKS; STORY BOOKS; NOTE BOOKS; CHILDREN'S INTERACTIVE EDUCATIONAL BOOKS; FLIP BOOKS; EDUCATIONAL PUBLICATIONS, NAMELY, EDUCATIONAL LEARNING CARDS, FLASH CARDS, ACTIVITY CARDS, WORKBOOKS, TEXTBOOKS, ACTIVITY BOOKS, STORY BOOKS, PUZZLE BOOKS, PRINTED PUZZLES, TEACHER GUIDES, MANUALS, POSTERS, EDUCATIONAL CARD GAMES AND EDUCATIONAL BOOKLETS IN THE FIELD OF TRAVEL AND ECOLOGICAL AND ENVIRONMENTAL AWARENESS; COMIC STRIPS; MAPS; GUIDE BOOKS FEATURING TRAVEL; ATLASES; GLOBES; DISPOSABLE SWIM PANTS FOR CHILDREN AND INFANTS; POSTERS; STICKERS; STATIONERY; BLANK JOURNALS; CALENDARS; DIARIES; INK STAMPS; STAMP ALBUMS; EVENT ALBUMS; PHOTOGRAPH ALBUMS; STICKER ALBUMS; POSTCARDS; PAINT BOXES AND BRUSHES; PAINTING SETS FOR CHILDREN; MODELING CLAY FOR CHILDREN; COLOR PENCILS; DECORATIONS FOR PENCILS; PENCIL CASES; PENCILS; FLASH CARDS; GREETING CARDS; HOLIDAY CARDS; INVITATION CARDS; MOTIVATIONAL CARDS; MUSICAL GREETING CARDS; OCCASION CARDS; GIFT CARDS; POST CARDS; TRADING CARDS; BANNERS OF PAPER; GIFT WRAPPING PAPER; HALLOWEEN GOODIE BAGS OF PAPER OR PLASTIC; PAPER BABY BIBS; PAPER BOWS FOR GIFT WRAP; PAPER CAKE DECORATIONS; PAPER GIFT WRAPPING RIBBONS; PAPER NAPKINS; PAPER PARTY BAGS; PAPER PARTY DECORATIONS; PAPER PARTY FAVORS; PAPER PLACE MATS; PAPER TABLE LINENS; PARTY GOODIE BAGS OF PAPER OR PLASTIC; SCHOOL SUPPLY KITS CONTAINING VARIOUS COMBINATIONS OF SELECTED SCHOOL SUPPLIES, NAMELY, WRITING INSTRUMENTS, PENS, PENCILS, MECHANICAL PENCILS, ERASERS, MARKERS, CRAYONS, HIGHLIGHTERS, FOLDERS, NOTEBOOKS, PAPER, GRADUATED RULERS, PROTRACTORS, PAPER CLIPS, PENCIL SHARPENERS, WRITING GRIPS, GLUE AND BOOK MARKS; DECORATIVE PAPER CENTERPIECES (U.S. CLS. 2, 5, 22, 23, 29, 37, 38 AND 50).  
FIRST USE 9-21-2009; IN COMMERCE 9-21-2009.

THE MARK CONSISTS OF STANDARD CHARACTERS WITHOUT CLAIM TO ANY PARTICULAR FONT, STYLE, SIZE, OR COLOR.

OWNER OF CANADA REG. NO. TMA745212, DATED 8-12-2009, EXPIRES 8-12-2024.

**CLASS 6—METAL GOODS**

FOR HAND-OPERATED METAL WINDING REELS FOR POOL COVERS AND PARTS THEREFOR (U.S. CLS. 2, 12, 13, 14, 23, 25 AND 50).  
FIRST USE 7-6-2009; IN COMMERCE 8-24-2010.

**CLASS 7—MACHINERY**

FOR POWER-OPERATED WINDING REELS FOR POOL COVERS AND PARTS THEREFOR (U.S. CLS. 13, 19, 21, 23, 31, 34 AND 35).  
FIRST USE 7-6-2009; IN COMMERCE 8-24-2010.

**CLASS 20—FURNITURE AND ARTICLES NOT OTHERWISE CLASSIFIED**

FOR HAND-OPERATED NON-METAL WINDING REELS FOR POOL COVERS AND PARTS THEREFOR (U.S. CLS. 2, 13, 22, 25, 32 AND 50).  
FIRST USE 7-6-2009; IN COMMERCE 8-24-2010.

**CLASS 25—CLOTHING**

FOR CHILDREN'S AND INFANTS' CLOTH BIBS; INFANT AND TODDLER ONE PIECE CLOTHING; BATHING SUITS; PAJAMAS; SHIRTS; PANTS; UNDERWEAR; SOCKS; DRESSES; SKIRTS; SWEATERS; COATS; JACKETS; HEADWEAR; FOOTWEAR (U.S. CLS. 22 AND 39).  
FIRST USE 5-15-2008; IN COMMERCE 5-15-2008.

3,941,083. 1099309 ONTARIO LTD, DBA ARMALAC INDUSTRIES, OSHAWA, ONTARIO, CANADA. SN 77-468,119. PUB. 5-12-2009, FILED 5-7-2008.

# ARMA

THE MARK CONSISTS OF STANDARD CHARACTERS WITHOUT CLAIM TO ANY PARTICULAR FONT, STYLE, SIZE, OR COLOR.

## CLASS 29—MEATS AND PROCESSED FOODS

FOR EDIBLE COATINGS, POLISHES AND GLAZES MADE OF SHELLAC (U.S. CL. 46).  
FIRST USE 10-1-2010; IN COMMERCE 10-1-2010.

## CLASS 30—STAPLE FOODS

FOR CONFECTIONERS COATINGS IN THE NATURE OF SHELLAC COATINGS FOR FOODS (U.S. CL. 46).  
FIRST USE 10-1-2010; IN COMMERCE 10-1-2010.

---

3,941,091. THE JIM HENSON COMPANY, INC., LOS ANGELES, CA. SN 77-488,886. PUB. 6-9-2009, FILED 6-2-2008.

# FRAGGLE ROCK

THE MARK CONSISTS OF STANDARD CHARACTERS WITHOUT CLAIM TO ANY PARTICULAR FONT, STYLE, SIZE, OR COLOR.

## CLASS 9—ELECTRICAL AND SCIENTIFIC APPARATUS

FOR A SERIES OF AUDIO-VISUAL RECORDINGS FEATURING CHILDREN'S ENTERTAINMENT; SOUND RECORDINGS FEATURING CHILDREN'S ENTERTAINMENT, MUSIC AND SOUNDTRACKS FROM TELEVISION PROGRAMS; DOWNLOADABLE SOUND RECORDINGS FEATURING CHILDREN'S ENTERTAINMENT; DOWNLOADABLE AUDIO-VISUAL RECORDINGS FEATURING CHILDREN'S ENTERTAINMENT; DOWNLOADABLE MEDIA, NAMELY, MULTIMEDIA FILES, TELEVISION SHOWS, ALL FEATURING CHILDREN'S ENTERTAINMENT; DOWNLOADABLE ELECTRONIC GAMES (U.S. CLS. 21, 23, 26, 36 AND 38).  
FIRST USE 0-0-1993; IN COMMERCE 0-0-1993.

## CLASS 16—PAPER GOODS AND PRINTED MATTER

FOR PRINTED MATERIALS, NAMELY, BOOKS ABOUT CHILDREN'S CHARACTERS, CHILDREN'S STORIES, CHILDREN'S BOOKS; POSTERS, NOTE CARDS, STATIONERY, PAPER SCHOOL SUPPLIES, NAMELY, PAPER, SCHOOL INDEX CARDS, SCHOOL WRITING BOOKS, PAPER DESK SUPPLIES, NAMELY, NOTEPADS (U.S. CLS. 2, 5, 22, 23, 29, 37, 38 AND 50).  
FIRST USE 0-0-1984; IN COMMERCE 0-0-1984.

## CLASS 25—CLOTHING

FOR CLOTHING, NAMELY, T-SHIRTS, SWEAT-SHIRTS, BELTS, LOUNGEWEAR, HATS, BASIC TOPS, FASHION TOPS, HEADWEAR, HALLOWEEN COSTUMES (U.S. CLS. 22 AND 39).  
FIRST USE 0-0-1993; IN COMMERCE 0-0-1993.

## CLASS 28—TOYS AND SPORTING GOODS

FOR TOYS AND GAMES, NAMELY, PLUSH TOYS, PLUSH DOLLS, PUPPETS, CHRISTMAS TREE ORNAMENTS (U.S. CLS. 22, 23, 38 AND 50).  
FIRST USE 0-0-1993; IN COMMERCE 0-0-1993.

## CLASS 41—EDUCATION AND ENTERTAINMENT

FOR ENTERTAINMENT SERVICES, NAMELY, LIVE APPEARANCES BY PROFESSIONAL ENTERTAINERS; A SERIES OF TELEVISION PROGRAMS IN THE FIELD OF CHILDREN'S ENTERTAINMENT; PROVIDING A WEBSITE WITH ENTERTAINMENT INFORMATION ON A CHILDREN'S ENTERTAINMENT PROPERTY, ITS CHARACTERS, STORIES AND BACKGROUND (U.S. CLS. 100, 101 AND 107).  
FIRST USE 0-0-1984; IN COMMERCE 0-0-1984.

---

3,941,104. HEALTHALND INC., GLENWOOD, MN. SN 77-514,605. PUB. 5-19-2009, FILED 7-3-2008.



THE MARK CONSISTS OF THE WORD "HEALTHLAND" WITH A DESIGN TO THE LEFT CONSISTING OF EACH OF FOUR PIE-SHAPED QUADRANTS OF A CIRCLE POSITIONED TO PARTIALLY FORM THE ARMS OF AN EQUILATERAL CROSS WITHOUT THE CENTER.

## CLASS 9—ELECTRICAL AND SCIENTIFIC APPARATUS

FOR COMPUTER SOFTWARE AND SYSTEMS, NAMELY, COMPUTER SOFTWARE AND SYSTEMS IN THE FIELD OF HEALTHCARE, NAMELY, COMPUTER SOFTWARE AND COMPUTER OPERATING SYSTEMS FOR USE IN DATABASE MANAGEMENT IN THE FIELD OF HEALTHCARE (U.S. CLS. 21, 23, 26, 36 AND 38).  
FIRST USE 9-15-2008; IN COMMERCE 9-15-2008.

## CLASS 35—ADVERTISING AND BUSINESS

FOR BUSINESS CONSULTANCY SERVICES, NAMELY, BUSINESS MANAGEMENT CONSULTING, BUSINESS MARKETING CONSULTING, AND BUSINESS INFORMATION SERVICES IN THE FIELD OF HEALTHCARE; PROFESSIONAL BUSINESS CONSULTING SERVICES, NAMELY, PREPARING CUSTOMIZED BUSINESS REPORTS, DESIGNING CUSTOMIZED ELECTRONIC BUSINESS FORMS, FINANCIAL SYSTEM COST ASSESSMENT, CLINICAL SYSTEM COST ASSESSMENT, NETWORK AND INFRASTRUCTURE COST ASSESSMENT, AND MAIL SORTING, HANDLING, AND RECEIVING, AND BILLING SERVICES IN THE FIELD OF HEALTHCARE; COMPUTERIZED DATABASE MANAGEMENT (U.S. CLS. 100, 101 AND 102).  
FIRST USE 9-15-2008; IN COMMERCE 9-15-2008.

**CLASS 37—CONSTRUCTION AND REPAIR**

FOR MAINTENANCE, UPDATING, UPGRADING, AND INSTALLATION, OF COMPUTER HARDWARE (U.S. CLS. 100, 103 AND 106).

FIRST USE 9-15-2008; IN COMMERCE 9-15-2008.

**CLASS 40—MATERIAL TREATMENT**

FOR PRINTING SERVICES IN THE FIELD OF HEALTHCARE (U.S. CLS. 100, 103 AND 106).

FIRST USE 9-15-2008; IN COMMERCE 9-15-2008.

**CLASS 41—EDUCATION AND ENTERTAINMENT**

FOR COMPUTER SOFTWARE AND COMPUTER SYSTEM EDUCATION TRAINING SERVICES; TRAINING SERVICES IN THE FIELD OF COMPUTER SOFTWARE AND COMPUTER SYSTEMS (U.S. CLS. 100, 101 AND 107).

FIRST USE 9-15-2008; IN COMMERCE 9-15-2008.

**CLASS 42—SCIENTIFIC AND COMPUTER SERVICES**

FOR COMPUTER SOFTWARE AND SYSTEMS SERVICES, NAMELY, DESIGN OF COMPUTER SOFTWARE, COMPUTER HARDWARE, AND COMPUTER NETWORKS FOR OTHERS; COMPUTER PROJECT MANAGEMENT, AND MAINTENANCE, UPDATING, UPGRADING, DEVELOPMENT, INSTALLATION, AND DUPLICATION OF COMPUTER SOFTWARE AND COMPUTER SOFTWARE SYSTEMS IN THE FIELD OF HEALTHCARE FOR OTHERS; PLANNING OF ELECTRONIC COMMUNICATION NETWORKS AND CONSULTANCY OF COMPUTER SOFTWARE AND COMPUTER SOFTWARE SYSTEMS IN THE FIELD OF HEALTHCARE FOR OTHERS; LEASING OF COMPUTERS; ANALYSIS OF COMPUTER PROGRAMMING AND COMPUTER SYSTEMS; COMPUTER PROGRAMMING; SOFTWARE ENGINEERING; TECHNICAL CONSULTATION IN THE FIELD OF SOFTWARE ENGINEERING; TECHNICAL SUPPORT SERVICES, NAMELY, MONITORING OF NETWORK SYSTEMS, PROVIDING BACK-UP COMPUTER PROGRAMS AND FACILITIES, AND TROUBLESHOOTING OF COMPUTER HARDWARE AND SOFTWARE PROBLEMS; DATABASE DEVELOPMENT SERVICES; IMPLEMENTATION SERVICES, NAMELY, CONSULTATION SERVICES IN THE FIELDS OF DATABASE IMPLEMENTATION AND INSTALLATION OF COMPUTER SOFTWARE; MAINTENANCE OF COMPUTER SOFTWARE THROUGH CONVERSION OF COMPUTER PROGRAM DATA OR INFORMATION; COMPUTER SERVICES, NAMELY, CREATING INDICES OF INFORMATION, SITES AND OTHER RESOURCES AVAILABLE ON COMPUTER NETWORKS; COMPUTER DATA RECOVERY SERVICES; AND INTEGRATION OF COMPUTER SYSTEMS AND NETWORKS; DESIGNING CUSTOMIZED ELECTRONIC BUSINESS FORMS (U.S. CLS. 100 AND 101).

FIRST USE 9-15-2008; IN COMMERCE 9-15-2008.

3,941,109. SCHRADER-BRIDGEPORT INTERNATIONAL, INC., ALTAVISTA, VA. SN 77-522,257. PUB. 5-25-2010, FILED 7-15-2008.



OWNER OF U.S. REG. NOS. 173,962, 174,164, AND 2,234,788.

THE MARK CONSISTS OF THE WORD "SCHRADER" WITH SPLIT OVAL.

**CLASS 6—METAL GOODS**

FOR METAL KEY RINGS, METAL COUPLERS FOR USE WITH AIR HOSE, METAL COUPLER PLUGS, METAL PUMP CONNECTORS AND COUPLINGS, AND MANUALLY OPERATED VALVES MADE PRINCIPALLY OF METAL (U.S. CLS. 2, 12, 13, 14, 23, 25 AND 50).

FIRST USE 10-4-2004; IN COMMERCE 10-4-2004.

**CLASS 7—MACHINERY**

FOR PNEUMATIC VALVES, AIR BLOW GUNS, HYDRAULIC AND PNEUMATIC ARBOR STANDS AND PRESSES, POWER OPERATED DRILL MACHINES, ROTARY INDEX TABLES FOR MACHINES, FOUNDRY MACHINE CYLINDERS, AIR MOTORS FOR MACHINES (U.S. CLS. 13, 19, 21, 23, 31, 34 AND 35).

FIRST USE 1-24-2005; IN COMMERCE 1-24-2005.

**CLASS 8—HAND TOOLS**

FOR HAND-OPERATED TIRE VALVE REPAIR TOOLS (U.S. CLS. 23, 28 AND 44).

FIRST USE 7-6-2007; IN COMMERCE 7-6-2007.

**CLASS 9—ELECTRICAL AND SCIENTIFIC APPARATUS**

FOR AIR-PRESSURE GAUGES, FLUID POWER SYSTEM CONTROL VALVES (U.S. CLS. 21, 23, 26, 36 AND 38).

FIRST USE 10-4-2004; IN COMMERCE 10-4-2004.

**CLASS 12—VEHICLES**

FOR TIRE VALVES FOR VEHICLE TIRES MADE OF RUBBER, PNEUMATIC TIRE VALVES FOR VEHICLE TIRES, PLASTIC TIRE VALVE EXTENSIONS AND CAPS, TIRE VALVE CORES, TIRE VALVES MADE OF METAL, METAL TIRE VALVE SLEEVES AND CAPS, AND METAL TIRE VALVE EXTENSIONS (U.S. CLS. 19, 21, 23, 31, 35 AND 44).

FIRST USE 1-31-2005; IN COMMERCE 1-31-2005.

3,941,111. PIONEER HI-BRED INTERNATIONAL, INC., JOHNSTON, IA. SN 77-525,977. PUB. 12-30-2008, FILED 7-18-2008.

Science With Service  
Delivering Success

THE MARK CONSISTS OF STANDARD CHARACTERS WITHOUT CLAIM TO ANY PARTICULAR FONT, STYLE, SIZE, OR COLOR.

**CLASS 16—PAPER GOODS AND PRINTED MATTER**

FOR NEWSLETTERS AND MAGAZINES PROVIDING AGRONOMIC, MARKETING AND CROP PLANNING INFORMATION TO THE AGRICULTURAL COMMUNITY (U.S. CLS. 2, 5, 22, 23, 29, 37, 38 AND 50).

FIRST USE 8-4-2009; IN COMMERCE 8-4-2009.

**CLASS 31—NATURAL AGRICULTURAL PRODUCTS**

FOR AGRICULTURAL PRODUCTS, NAMELY, SEEDS, GRAINS AND LEGUMES FOR PLANTING (U.S. CLS. 1 AND 46).

FIRST USE 8-4-2009; IN COMMERCE 8-4-2009.

**CLASS 44—MEDICAL, BEAUTY AND AGRICULTURAL SERVICES**

FOR AGRICULTURAL ADVICE IN THE FIELD OF CROP PLANNING (U.S. CLS. 100 AND 101).  
FIRST USE 8-4-2009; IN COMMERCE 8-4-2009.

3,941,116. GIRLS WRITE NOW, INC., NEW YORK, NY. SN 77-542,053. PUB. 5-26-2009, FILED 8-7-2008.

**GIRLS WRITE NOW**

THE MARK CONSISTS OF STANDARD CHARACTERS WITHOUT CLAIM TO ANY PARTICULAR FONT, STYLE, SIZE, OR COLOR.

NO CLAIM IS MADE TO THE EXCLUSIVE RIGHT TO USE "GIRLS", APART FROM THE MARK AS SHOWN.

**CLASS 16—PAPER GOODS AND PRINTED MATTER**

FOR PRINTED PUBLICATIONS, NAMELY, ANNUAL ANTHOLOGIES IN THE FIELD OF WRITING (U.S. CLS. 2, 5, 22, 23, 29, 37, 38 AND 50).  
FIRST USE 9-1-2000; IN COMMERCE 9-1-2000.

**CLASS 41—EDUCATION AND ENTERTAINMENT**

FOR EDUCATIONAL, INSTRUCTIONAL AND TRAINING SERVICES, NAMELY, ARRANGING AND CONDUCTING CLASSES, SEMINARS, CLINICS, LECTURES, WORKSHOPS, TUTORING, TUTORING SESSIONS, MENTORING, ONE-ON-ONE MENTORING, FIELD TRIPS, READINGS, AND CONFERENCES FOR EDUCATORS, WRITERS, PARENTS AND STUDENTS IN THE FIELD OF WRITING, DEVELOPING CURRICULA FOR OTHERS IN THE FIELD OF WRITING (U.S. CLS. 100, 101 AND 107).

FIRST USE 9-1-2000; IN COMMERCE 9-1-2000.

3,941,117. GIRLS WRITE NOW, INC., NEW YORK, NY. SN 77-542,057. PUB. 5-26-2009, FILED 8-7-2008.



NO CLAIM IS MADE TO THE EXCLUSIVE RIGHT TO USE "GIRLS", APART FROM THE MARK AS SHOWN.

THE MARK CONSISTS OF THE WORD "GIRLS" WITH A STYLIZED LETTER "G", WHEREIN THE WORD "GIRLS" IS PLACED IN THE FOREFRONT OF A SOLID CIRCLE. THE WORDS "WRITE NOW" ARE PLACED ON THE OUTER RIGHT SIDE OF THE SOLID CIRCLE.

**CLASS 16—PAPER GOODS AND PRINTED MATTER**

FOR PRINTED PUBLICATIONS, NAMELY, ANNUAL ANTHOLOGIES IN THE FIELD OF WRITING (U.S. CLS. 2, 5, 22, 23, 29, 37, 38 AND 50).  
FIRST USE 8-1-2003; IN COMMERCE 8-1-2003.

**CLASS 41—EDUCATION AND ENTERTAINMENT**

FOR EDUCATIONAL, INSTRUCTIONAL AND TRAINING SERVICES, NAMELY, ARRANGING AND CONDUCTING CLASSES, SEMINARS, CLINICS, LECTURES, WORKSHOPS, TUTORING, TUTORING SESSIONS, MENTORING, ONE-ON-ONE MENTORING, FIELD TRIPS, READINGS, AND CONFERENCES FOR EDUCATORS, WRITERS, PARENTS AND STUDENTS IN THE FIELD OF WRITING, DEVELOPING CURRICULA FOR OTHERS IN THE FIELD OF WRITING (U.S. CLS. 100, 101 AND 107).

FIRST USE 8-1-2003; IN COMMERCE 8-1-2003.

3,941,119. PROEX PHYSICAL THERAPY, LLC., KITTERY, ME. SN 77-545,606. PUB. 6-30-2009, FILED 8-13-2008.

**PEOPLE FOCUSED PHYSICAL THERAPY**

THE MARK CONSISTS OF STANDARD CHARACTERS WITHOUT CLAIM TO ANY PARTICULAR FONT, STYLE, SIZE, OR COLOR.

NO CLAIM IS MADE TO THE EXCLUSIVE RIGHT TO USE "PHYSICAL THERAPY", APART FROM THE MARK AS SHOWN.

**CLASS 16—PAPER GOODS AND PRINTED MATTER**

FOR PUBLICATIONS, NAMELY, MANUALS, WORKBOOKS, TEXTBOOKS, BROCHURES, AND PAMPHLETS IN THE FIELDS OF PHYSICAL THERAPY AND ATHLETIC TRAINING (U.S. CLS. 2, 5, 22, 23, 29, 37, 38 AND 50).

FIRST USE 5-2-2009; IN COMMERCE 5-2-2009.

**CLASS 41—EDUCATION AND ENTERTAINMENT**

FOR ATHLETIC TRAINING SERVICES (U.S. CLS. 100, 101 AND 107).

FIRST USE 5-2-2009; IN COMMERCE 5-2-2009.

**CLASS 44—MEDICAL, BEAUTY AND AGRICULTURAL SERVICES**

FOR PHYSICAL THERAPY SERVICES; PROVIDING AN ON-LINE WEBSITE WITH INFORMATION IN THE FIELD OF PHYSICAL THERAPY (U.S. CLS. 100 AND 101).

FIRST USE 4-16-2009; IN COMMERCE 4-16-2009.

3,941,120. UNITED STATES MINERAL PRODUCTS COMPANY, DBA ISOLATEK INTERNATIONAL, STANHOPE, NJ. SN 77-546,346. PUB. 1-6-2009, FILED 8-13-2008.



NO CLAIM IS MADE TO THE EXCLUSIVE RIGHT TO USE "INTERNATIONAL", APART FROM THE MARK AS SHOWN.

THE MARK CONSISTS OF "ISOLATEK INTERNATIONAL" IN WHICH A GLOBE IS USED TO DEPICT THE LETTER "O" IN "ISOLATEK" AND "INTERNATIONAL" APPEARS IN A BOX BELOW "ISOLATEK".

#### CLASS 1—CHEMICALS

FOR ADHESIVES FOR USE IN SOUND AND HEAT INSULATION, CONDENSATION CONTROL AND FIRE PROTECTION IN THE CONSTRUCTION INDUSTRY; SPRAY APPLIED FIRE PROOFING CHEMICALS; ACCELERANTS FOR USE WITH CEMENTITIOUS SLURRIES (U.S. CLS. 1, 5, 6, 10, 26 AND 46).  
FIRST USE 6-30-2010; IN COMMERCE 6-30-2010.

#### CLASS 2—PAINTS

FOR SEALER COATINGS, INTUMESCENT PAINTS, INTUMESCENT COATINGS AND COATINGS ALL USED FOR CONDENSATION CONTROL AND FIRE PROTECTION IN THE CONSTRUCTION INDUSTRY (U.S. CLS. 6, 11 AND 16).  
FIRST USE 4-30-2010; IN COMMERCE 4-30-2010.

#### CLASS 17—RUBBER GOODS

FOR FIRE RESISTIVE BOARD, SPRAY APPLIED MINERAL WOOL AND NON-MINERAL WOOL PRODUCTS FOR USE AS SOUND AND HEAT INSULATION, CONDENSATION CONTROL AND FIRE RESISTANCE; SPRAY APPLIED HIGH TEMPERATURE INDUSTRIAL INSULATION; SEALANTS FOR BUILDINGS FOR USE IN SOUND AND HEAT INSULATION, CONDENSATION CONTROL AND FIRE RESISTANCE IN THE CONSTRUCTION INDUSTRY; SEALER COATINGS, INTUMESCENT PAINTS, INTUMESCENT COATINGS AND COATINGS ALL USED AS INSULATION FOR SOUND AND HEAT IN THE CONSTRUCTION INDUSTRY (U.S. CLS. 1, 5, 12, 13, 35 AND 50).  
FIRST USE 4-30-2010; IN COMMERCE 4-30-2010.

3,941,121. MOTOROLA TRADEMARK HOLDINGS, LLC, LIBERTYVILLE, IL. SN 77-547,252. PUB. 12-2-2008, FILED 8-14-2008.

# ECOMOTO

THE MARK CONSISTS OF STANDARD CHARACTERS WITHOUT CLAIM TO ANY PARTICULAR FONT, STYLE, SIZE, OR COLOR.

OWNER OF U.S. REG. NOS. 3,006,545, 3,402,839, AND OTHERS.

#### CLASS 9—ELECTRICAL AND SCIENTIFIC APPARATUS

FOR TELEPHONES, CELLULAR TELEPHONES, RADIO TRANSCEIVERS, PERSONAL DIGITAL ASSISTANTS, PORTABLE AUDIO AND VIDEO PLAYERS, ELECTRONIC MESSAGE DEVICES, ELECTRONIC CAMERAS, NAMELY, DIGITAL CAMERAS, VIDEO CAMERAS; GLOBAL POSITIONING UNITS, BATTERIES, BATTERY CHARGERS AND POWER ADAPTERS (U.S. CLS. 21, 23, 26, 36 AND 38).

FIRST USE 1-18-2009; IN COMMERCE 1-18-2009.

#### CLASS 40—MATERIAL TREATMENT

FOR RECYCLING SERVICES (U.S. CLS. 100, 103 AND 106).

FIRST USE 1-0-2005; IN COMMERCE 1-0-2005.

3,941,125. ROSETREE, ROSE, STERLING, VA. SN 77-554,398. PUB. 3-10-2009, FILED 8-24-2008.

# EMPATH EMPOWERMENT

THE MARK CONSISTS OF STANDARD CHARACTERS WITHOUT CLAIM TO ANY PARTICULAR FONT, STYLE, SIZE, OR COLOR.

NO CLAIM IS MADE TO THE EXCLUSIVE RIGHT TO USE "EMPATH", APART FROM THE MARK AS SHOWN.

#### CLASS 41—EDUCATION AND ENTERTAINMENT

FOR EDUCATIONAL SERVICES, NAMELY, PROVIDING CLASSES, SEMINARS AND WORKSHOPS FEATURING INSTRUCTION FOR EMPATHS TO BECOME SKILLED IN THE USE OF THEIR INNATE GIFTS AND THE PROVISION OF CONCEPTS AND DEFINITIONS FOR DIFFERENT EMPATHIC GIFTS, CONCEPTUAL MODELS FOR HOW EMPATHIC GIFTS FUNCTION AND SUPPLYING SPECIFIC TECHNIQUES FOR TURNING THOSE GIFTS OFF AND TECHNIQUES FOR TURNING THOSE GIFTS ON; PERSONAL LIFE COACHING SERVICES IN THE FIELD OF EMPATHIC GIFTS, NAMELY, BECOMING A SKILLED EMPATH AND UTILIZING ONE'S GIFTS AT WILL (U.S. CLS. 100, 101 AND 107).

FIRST USE 1-17-2011; IN COMMERCE 1-17-2011.

#### CLASS 45—PERSONAL AND LEGAL SERVICES

FOR PSYCHIC READING SERVICES; SPIRITUAL COUNSELING FOR SKILLED EMPATHS; COUNSELING IN THE FIELD OF PERSONAL DEVELOPMENT, NAMELY, SELF-IMPROVEMENT, SELF-FULFILLMENT, AND INTERPERSONAL COMMUNICATION FOR SKILLED EMPATHS (U.S. CLS. 100 AND 101).

FIRST USE 1-17-2011; IN COMMERCE 1-17-2011.

3,941,126. LOMINGER LIMITED, INC., DBA LOMINGER INTERNATIONAL, A KORN/FERRY COMPANY, MINNEAPOLIS, MN. SN 77-554,863. PUB. 5-5-2009, FILED 8-25-2008.

# LOMINGER INTERNATIONAL

THE MARK CONSISTS OF STANDARD CHARACTERS WITHOUT CLAIM TO ANY PARTICULAR FONT, STYLE, SIZE, OR COLOR.

NO CLAIM IS MADE TO THE EXCLUSIVE RIGHT TO USE "INTERNATIONAL", APART FROM THE MARK AS SHOWN.



**CLASS 16—PAPER GOODS AND PRINTED MATTER**

FOR PRINTED PRODUCTS, NAMELY, EDUCATIONAL MATERIALS FOR USE BY INDIVIDUALS AND BUSINESSES TO EVALUATE LEADERSHIP AND MANAGERIAL APTITUDES AND SKILLS FOR THE PURPOSE OF DEVELOPING AND IMPLEMENTING LEADERSHIP DEVELOPMENT AND SUCCESSION PLANS FOR BUSINESSES, WORKING UNITS AND INDIVIDUALS (U.S. CLS. 2, 5, 22, 23, 29, 37, 38 AND 50).  
FIRST USE 6-1-2007; IN COMMERCE 6-1-2007.

**CLASS 42—SCIENTIFIC AND COMPUTER SERVICES**

FOR PROVIDING TEMPORARY USE OF NON-DOWNLOADABLE COMPUTER PROGRAMS ACCESSIBLE ON A GLOBAL COMPUTER NETWORK FOR USE BY INDIVIDUALS AND BUSINESSES FOR ONLINE EVALUATION, MANAGERIAL APTITUDES AND IMPROVEMENT OF RECRUITING, ANALYSIS AND EVALUATION SKILLS, JOB PERFORMANCE AND JOB DEVELOPMENT, SKILLS FOR THE PURPOSE OF DEVELOPING AND IMPLEMENTING LEADERSHIP DEVELOPMENT AND SUCCESSION PLANS FOR BUSINESSES AND INDIVIDUALS (U.S. CLS. 100 AND 101).  
FIRST USE 6-1-2002; IN COMMERCE 6-1-2002.

---

3,941,128. RAPP COLLINS WORLDWIDE INC., NEW YORK, NY. SN 77-561,173. PUB. 6-1-2010, FILED 9-3-2008.

**RAPP**

THE MARK CONSISTS OF STANDARD CHARACTERS WITHOUT CLAIM TO ANY PARTICULAR FONT, STYLE, SIZE, OR COLOR.

**CLASS 35—ADVERTISING AND BUSINESS**

FOR ADVERTISING AND MARKETING SERVICES; PROMOTIONAL SERVICES; PUBLIC RELATIONS SERVICES; BRAND IMAGERY CONSULTING SERVICES, NAMELY, BRAND CONSULTANCY, BRAND CREATION SERVICES, BRAND EVALUATION SERVICES, BRAND POSITIONING, BRAND TESTING, AND BRAND STRATEGY; MARKETING AND ADVERTISING MEDIA MANAGEMENT SERVICES; MEDIA BUYING SERVICES, NAMELY, PURCHASING TIME AND SPACE FOR THE DELIVERY OF ADVERTISING MESSAGES THROUGH BROADCAST TIME, PRINT SPACE, INDOOR SPACE, OUTDOOR SPACE, AND TELEVISION AND INTERNET MEDIA; CORPORATE EVENT MANAGEMENT AND MARKETING SERVICES; PROFESSIONAL CONSULTATION AND ADVICE RELATING TO CORPORATE EVENT MANAGEMENT AND MARKETING SERVICES; SPONSORSHIP SEARCH CONSULTANCY SERVICES; BUSINESS RESEARCH; MARKET RESEARCH; BUSINESS MANAGEMENT CONSULTANCY SERVICES; BUSINESS MANAGEMENT OF EVENT HOSPITALITY SERVICES; CONDUCTING OPINION POLLS; COMPILATION, PROCESSING AND ANALYSIS OF STATISTICS; BUSINESS NETWORKING SERVICES; ARRANGING AND CONDUCTING OF COMMERCIAL EXHIBITIONS IN THE FIELD OF BUSINESS NETWORKING; PREPARING AND PLACING OF ADVERTISEMENTS FOR RADIO, VIDEO, FILM, COMPUTERS, INTERNET WEB SITES, TELEVISION AND MOBILE DEVICES; ADVERTISING BY MAIL ORDER; COMPILATION OF DIRECT MAILING LISTS; COMPILATION OF MAILING LISTS; DIRECT MAIL ADVERTISING; MARKETING BY MAIL; PREPARATION OF MAILING LISTS; PREPARATION OF MAILING LISTS FOR DIRECT MAIL ADVERTISING SERVICES; DIRECT MARKETING, DATABASE MARKETING, TELEMARKETING; STATISTICAL ANALYSIS AND REPORTING FOR BUSINESS PURPOSES; DATABASE MANAGEMENT; BUSINESS INFORMATION SERVICES; DIRECT MAIL ADVERTISING SERVICES; BUSINESS CONSULTING SERVICES IN THE FIELD OF ELECTRONIC COMMERCE; ADVERTISING AND MARKETING MANAGEMENT AGENCY SERVICES, NAMELY, THE CREATION, DEVELOPMENT AND DISSEMINATION OF ADVERTISING AND PROMOTIONAL MATERIALS VIA DIRECT MAIL, NEWSPAPER, RADIO, TELEVISION, MOBILE DEVICES, A GLOBAL COMPUTER NETWORK AND OTHER INTERACTIVE MEDIA; MOBILE ADVERTISEMENTS AND DIRECT MAIL ADVERTISEMENTS; PRODUCTION OF TELEVISION COMMERCIALS; DISTRIBUTION OF TELEVISION COMMERCIAL FOR OTHERS (U.S. CLS. 100, 101 AND 102).  
FIRST USE 9-1-2008; IN COMMERCE 9-1-2008.

**CLASS 39—TRANSPORTATION AND STORAGE**

FOR PROVIDING ONLINE STORAGE OF DIGITAL CONTENT, MEDIA, AND IMAGES AND ELECTRONICALLY-STORED DATA, INFORMATION, COMPUTER FILES, PHOTOGRAPHS, VIDEOS, TEXT AND DOCUMENTS; ELECTRONIC STORAGE OF DIGITAL CONTENT, MEDIA, AND IMAGES AND ELECTRONICALLY-STORED DATA, INFORMATION, COMPUTER FILES, PHOTOGRAPHS, VIDEOS, TEXT AND DOCUMENTS; COMPUTER SERVICES, NAMELY, STORAGE OF RESOURCES AVAILABLE ON COMPUTER NETWORKS (U.S. CLS. 100 AND 105).  
FIRST USE 9-1-2008; IN COMMERCE 9-1-2008.

**CLASS 41—EDUCATION AND ENTERTAINMENT**

FOR FILM, VIDEO, AND SOUND RECORDING PRODUCTION AND POST PRODUCTION SERVICES; PRODUCTION OF SOUND AND MUSIC VIDEO RECORDINGS; SOUND EDITING AND ENHANCEMENT; EDITING AND RECORDING OF SOUNDS, NAMELY, MIXING OF DIALOGUE, MUSIC, SOUND EFFECTS, DIALOGUE AND NARRATION, AND AUTOMATED DIALOGUE REPLACEMENT; AUDIO POST-PRODUCTION EDITING, AUDIO TRACK EDITING AND AUGMENTATION; DUBBING SERVICES, NAMELY, FOREIGN LANGUAGE DUBBING; AUDIO AND VIDEO POST PRODUCTION EDITING SERVICES;

VIDEO POST-PRODUCTION EDITING SERVICES, NAMELY, ADDING VISUAL EFFECTS AND GRAPHICS TO VIDEO TAPE, AUDIO TAPE, DIGITAL MEDIA AND FILM; VIDEO, CD, AND DVD MASTERING SERVICES OF FILM, DIGITAL MEDIA AND VIDEO TAPE; SPECIAL-EFFECTS DESIGN FOR OTHERS FOR ADVERTISEMENTS, FILMS, AND TELEVISION; RENTAL SERVICES FOR AUDIO AND VIDEO EQUIPMENT FOR USE IN POST-PRODUCTION WORK; ENTERTAINMENT INFORMATION CONSULTATION; PUBLISHING OF ELECTRONIC PUBLICATIONS (U.S. CLS. 100, 101 AND 107).

FIRST USE 9-1-2008; IN COMMERCE 9-1-2008.

#### **CLASS 42—SCIENTIFIC AND COMPUTER SERVICES**

FOR DESIGN RESEARCH, NAMELY, DESIGN OF COMPUTER SOFTWARE; GRAPHIC ILLUSTRATION DESIGN SERVICES FOR OTHERS; SCIENTIFIC RESEARCH AND DEVELOPMENT OF PACKAGING; TECHNICAL WRITING FOR OTHERS; COMPUTER SERVICES, NAMELY, COMPUTER WEBSITE DESIGN; DESIGN FOR OTHERS IN THE FIELD OF COMPUTERS AND BANNER ADVERTISEMENTS; GRAPHIC DESIGN SERVICES (U.S. CLS. 100 AND 101).

FIRST USE 9-1-2008; IN COMMERCE 9-1-2008.

3,941,130. DOYLE'S VALVES, INC., DBA DOYLES, HOUSTON, TX. SN 77-565,180. PUB. 4-28-2009, FILED 9-8-2008.



THE COLOR(S) YELLOW, BLACK AND WHITE IS/ARE CLAIMED AS A FEATURE OF THE MARK.

THE MARK CONSISTS OF A NATIVE AMERICAN CHIEF IN WHITE WITH BLACK OUTLINING AND BLACK OUTLINED FEATURES, WEARING A HEADDRESS IN WHITE WITH BLACK OUTLINING AND BLACK SHADING, AGAINST A YELLOW CIRCLE OUTLINED IN BLACK; THE WORD "DOYLES" IN BLACK ABOVE THE CIRCLE DESIGN; AND THE WORDING "CHIEF OF THE TRADE" IN WHITE AGAINST A BLACK BANNER DESIGN BELOW THE CIRCLE DESIGN.

#### **CLASS 7—MACHINERY**

FOR DRILLING RIGS; OIL-WELL PUMPING MACHINES; VALVES BEING PARTS OF OILFIELD PRESSURE CONTROL EQUIPMENT AND MACHINES, NOT BEING PRESSURE RELIEF VALVES; WELL DRILLING MACHINES (U.S. CLS. 13, 19, 21, 23, 31, 34 AND 35).

FIRST USE 12-31-2007; IN COMMERCE 1-31-2008.

#### **CLASS 9—ELECTRICAL AND SCIENTIFIC APPARATUS**

FOR CONTROL VALVES FOR REGULATING THE FLOW OF GASES AND LIQUIDS; PRESSURE CONTROL EQUIPMENT, NAMELY, BLOWOUT PREVENTERS; PRESSURE RELIEF VALVES FOR OIL WELLS; SAFETY VALVES FOR FLOW SHUTOFF IN WELL CONSTRUCTION (U.S. CLS. 21, 23, 26, 36 AND 38).

FIRST USE 12-31-2007; IN COMMERCE 1-31-2008.

#### **CLASS 35—ADVERTISING AND BUSINESS**

FOR SERVICES COMPRISING THE RECORDING, TRANSCRIPTION, COMPOSITION, COMPILATION AND SYSTEMATIZATION OF WRITTEN COMMUNICATIONS AND RECORDINGS, AS WELL AS THE COMPILATION OF MATHEMATICAL OR STATISTICAL DATA (U.S. CLS. 100, 101 AND 102).

FIRST USE 12-31-2007; IN COMMERCE 1-31-2008.

#### **CLASS 37—CONSTRUCTION AND REPAIR**

FOR DRILLING AND PUMPING OF OIL; DRILLING FOR CRUDE OIL; DRILLING OF WELLS; MAINTENANCE AND/OR REPAIR OF OILFIELD PRESSURE CONTROL EQUIPMENT; OIL AND GAS DRILLING; OIL WELL DRILLING; RENTAL OF OIL WELL DRILLING TOOLS; WELL DRILLING (U.S. CLS. 100, 103 AND 106).

FIRST USE 12-31-2007; IN COMMERCE 1-31-2008.

#### **CLASS 42—SCIENTIFIC AND COMPUTER SERVICES**

FOR OIL WELL TESTING (U.S. CLS. 100 AND 101).  
FIRST USE 12-31-2007; IN COMMERCE 1-31-2008.

3,941,131. HARMON, NICK L., ALBUQUERQUE, NM. SN 77-566,650. PUB. 2-16-2010, FILED 9-10-2008.

## **FRESCO HARMONY**

THE MARK CONSISTS OF STANDARD CHARACTERS WITHOUT CLAIM TO ANY PARTICULAR FONT, STYLE, SIZE, OR COLOR.

#### **CLASS 17—RUBBER GOODS**

FOR COATINGS FOR SURFACE TEXTURE AND FINISH APPLICATIONS, NAMELY, JOINT COMPOUNDS (U.S. CLS. 1, 5, 12, 13, 35 AND 50).

FIRST USE 9-10-2008; IN COMMERCE 10-30-2010.

#### **CLASS 19—NON-METALLIC BUILDING MATERIALS**

FOR COATINGS FOR SURFACE TEXTURE AND FINISH APPLICATIONS, NAMELY, PIGMENTED WALL MUD AND PLASTERS (U.S. CLS. 1, 12, 33 AND 50).

FIRST USE 9-10-2008; IN COMMERCE 10-30-2010.

3,941,135. ACTION FENCE CONTRACTORS, INC., DBA ACTION FENCE, MUNDELEIN, IL. SN 77-575,178. PUB. 5-25-2010, FILED 9-21-2008.



NO CLAIM IS MADE TO THE EXCLUSIVE RIGHT TO USE "FENCE" AND "SINCE 1975", APART FROM THE MARK AS SHOWN.

THE MARK CONSISTS OF THE CAPITAL LETTERS "AFC", INSIDE A PARALLELOGRAM FIGURE, WITH THE WORD "ACTION" IN CAPITAL LETTERS, ABOVE THE WORDS, "SINCE 1975" AND THE WORD "FENCE" ALL WITHIN A RECTANGULAR DESIGN ELEMENT.

#### CLASS 6—METAL GOODS

FOR METAL FENCING AND GATES, NAMELY, ORNAMENTAL IRON, STEEL, AND ALUMINUM FENCING AND GATES (U.S. CLS. 2, 12, 13, 14, 23, 25 AND 50).

FIRST USE 5-6-2010; IN COMMERCE 5-6-2010.

#### CLASS 19—NON-METALLIC BUILDING MATERIALS

FOR NON-METAL FENCING AND GATES; NON-METAL CHAIN LINK FENCING AND GATES; PVC FENCING AND GATES (U.S. CLS. 1, 12, 33 AND 50).

FIRST USE 5-6-2010; IN COMMERCE 5-6-2010.

#### CLASS 37—CONSTRUCTION AND REPAIR

FOR CONSTRUCTION AND INSTALLATION OF FENCING AND GATES FOR RESIDENTIAL CUSTOMERS (U.S. CLS. 100, 103 AND 106).

FIRST USE 6-1-1976; IN COMMERCE 7-1-1977.

3,941,143. ELECTROLUX HOME PRODUCTS, INC., CLEVELAND, OH. SN 77-585,492. PUB. 7-7-2009, FILED 10-3-2008.

# TIME WISE

THE MARK CONSISTS OF STANDARD CHARACTERS WITHOUT CLAIM TO ANY PARTICULAR FONT, STYLE, SIZE, OR COLOR.

#### CLASS 7—MACHINERY

FOR WASH TIME REGULATING FEATURE SOLD AS AN INTEGRAL COMPONENT OF CLOTHES WASHERS, AND OF LAUNDRY CENTERS, NAMELY, CLOTHES WASHERS COMBINED WITH CLOTHES DRYERS (U.S. CLS. 13, 19, 21, 23, 31, 34 AND 35).

FIRST USE 5-1-2006; IN COMMERCE 5-1-2006.

#### CLASS 11—ENVIRONMENTAL CONTROL APPARATUS

FOR DRY TIME REGULATING FEATURE SOLD AS AN INTEGRAL COMPONENT OF CLOTHES DRYERS, AND OF LAUNDRY CENTERS, NAMELY, CLOTHES DRYERS COMBINED WITH CLOTHES WASHERS (U.S. CLS. 13, 21, 23, 31 AND 34).

FIRST USE 5-1-2006; IN COMMERCE 5-1-2006.

3,941,144. ELECTROLUX HOME PRODUCTS, INC., CLEVELAND, OH. SN 77-585,493. PUB. 7-7-2009, FILED 10-3-2008.

# SPACEWISE

THE MARK CONSISTS OF STANDARD CHARACTERS WITHOUT CLAIM TO ANY PARTICULAR FONT, STYLE, SIZE, OR COLOR.

#### CLASS 7—MACHINERY

FOR BASKETS AND RACKS SOLD AS COMPONENT FEATURE WITH APPLIANCES, NAMELY, DISHWASHERS (U.S. CLS. 13, 19, 21, 23, 31, 34 AND 35).

FIRST USE 3-15-2009; IN COMMERCE 3-15-2009.

#### CLASS 11—ENVIRONMENTAL CONTROL APPARATUS

FOR BASKETS, SHELVES, RACKS AND BINS SOLD AS COMPONENT FEATURE WITH APPLIANCES, NAMELY, REFRIGERATORS; SHELVES AND RACKS SOLD AS A COMPONENT FEATURE WITH APPLIANCES, NAMELY, SLIDE IN AND FREESTANDING GAS AND ELECTRIC RANGES, SLIDE IN AND FREESTANDING GAS AND ELECTRIC STOVES, DOUBLE AND SINGLE GAS AND ELECTRIC WALL OVENS (U.S. CLS. 13, 21, 23, 31 AND 34).

FIRST USE 3-15-2009; IN COMMERCE 3-15-2009.

3,941,147. BANCVue, LTD., AUSTIN, TX. SN 77-593,264. PUB. 3-3-2009, FILED 10-15-2008.

# RealSaver

THE MARK CONSISTS OF STANDARD CHARACTERS WITHOUT CLAIM TO ANY PARTICULAR FONT, STYLE, SIZE, OR COLOR.

#### CLASS 35—ADVERTISING AND BUSINESS

FOR PROVIDING PROMOTIONAL MARKETING FOR THE BANKING SERVICES OF OTHERS (U.S. CLS. 100, 101 AND 102).

FIRST USE 1-1-2009; IN COMMERCE 1-1-2009.

**CLASS 36—INSURANCE AND FINANCIAL**

FOR BANKING SERVICES; CHECKING AND SAVINGS ACCOUNT SERVICES (U.S. CLS. 100, 101 AND 102).

FIRST USE 1-1-2009; IN COMMERCE 1-1-2009.

3,941,148. SHEETZ OF DELAWARE, INC., WILMINGTON, DE. SN 77-594,204. PUB. 3-17-2009, FILED 10-16-2008.



OWNER OF U.S. REG. NOS. 1,274,635, 3,254,024, AND OTHERS.

NO CLAIM IS MADE TO THE EXCLUSIVE RIGHT TO USE "MADE TO ORDER", APART FROM THE MARK AS SHOWN.

THE MARK CONSISTS OF A SHADED OVAL CONTAINING WAVY LINES AND SWIRLS IN THE BACKGROUND. THE LETTERS "M.T.O." ARE DISPLAYED INSIDE THE OVAL. A SHADED RECTANGLE CONTAINING THE WORD "SHEETZ" IS DISPLAYED ABOVE THE LETTERS "M.T.O." A BANNER IS DISPLAYED ON THE BOTTOM OF THE OVAL AND CONTAINS THE WORDING "MADE-TO-ORDER".

SEC. 2(F) AS TO "MTO".

**CLASS 29—MEATS AND PROCESSED FOODS**

FOR SALADS, EXCEPT MACARONI, RICE AND PASTA (U.S. CL. 46).

FIRST USE 5-0-2007; IN COMMERCE 5-0-2007.

**CLASS 30—STAPLE FOODS**

FOR SANDWICHES AND MACARONI, RICE, GRAIN AND PASTA SALADS FOR CONSUMPTION ON AND OFF THE PREMISES (U.S. CL. 46).

FIRST USE 5-0-2007; IN COMMERCE 5-0-2007.

3,941,151. MATTHEW R. KYLE, MINNEAPOLIS, MN. SN 77-600,262. PUB. 5-19-2009, FILED 10-24-2008.

**CIRCLE BIOLOGICS**

THE MARK CONSISTS OF STANDARD CHARACTERS WITHOUT CLAIM TO ANY PARTICULAR FONT, STYLE, SIZE, OR COLOR.

NO CLAIM IS MADE TO THE EXCLUSIVE RIGHT TO USE "BIOLOGICS", APART FROM THE MARK AS SHOWN.

**CLASS 9—ELECTRICAL AND SCIENTIFIC APPARATUS**

FOR LABORATORY DEVICES, NAMELY, BIOLOGICAL CONCENTRATORS AND SEPARATORS IN THE NATURE OF BLOOD, BIOLOGICAL FLUID, TISSUE AND/OR CELL COMPONENT SEPARATION AND CONCENTRATION APPARATUS FOR LABORATORY USE; LABORATORY FILTERS (U.S. CLS. 21, 23, 26, 36 AND 38).

FIRST USE 1-25-2011; IN COMMERCE 1-25-2011.

**CLASS 10—MEDICAL APPARATUS**

FOR MEDICAL DEVICES, NAMELY, BIOLOGICAL CONCENTRATORS AND SEPARATORS IN THE NATURE OF BLOOD, BIOLOGICAL FLUID, TISSUE AND/OR CELL COMPONENT SEPARATION AND CONCENTRATION APPARATUS FOR MEDICAL USE; BLOOD OR BIOLOGICAL FLUID FILTERS FOR MEDICAL USE; MEDICAL DEVICES, NAMELY, BIOLOGICAL AND CHEMICAL FLUID AND MATERIAL TRANSFER DEVICES FOR THE TRANSFER OF FLUID AND MATERIALS FROM A NON-STERILE FIELD TO A STERILE FIELD IN THE NATURE OF COUPLERS FOR MEDICAL SYRINGES, TEST TUBES, SPECIMEN TUBES, IV TUBING AND PLASTIC BAGS FOR MEDICAL, BIOLOGICAL OR CHEMICAL FLUID AND MATERIAL TRANSFER (U.S. CLS. 26, 39 AND 44).

FIRST USE 1-25-2011; IN COMMERCE 1-25-2011.

3,941,152. MATTHEW R. KYLE, MINNEAPOLIS, MN. SN 77-600,281. PUB. 5-19-2009, FILED 10-24-2008.



THE MARK CONSISTS OF A STYLIZED CIRCLE DESIGN.

**CLASS 9—ELECTRICAL AND SCIENTIFIC APPARATUS**

FOR LABORATORY DEVICES, NAMELY, BIOLOGICAL CONCENTRATORS AND SEPARATORS IN THE NATURE OF BLOOD, BIOLOGICAL FLUID, TISSUE AND/OR CELL COMPONENT SEPARATION AND CONCENTRATION APPARATUS FOR LABORATORY USE; LABORATORY FILTERS (U.S. CLS. 21, 23, 26, 36 AND 38).

FIRST USE 1-25-2011; IN COMMERCE 1-25-2011.

**CLASS 10—MEDICAL APPARATUS**

FOR MEDICAL DEVICES, NAMELY, BIOLOGICAL CONCENTRATORS AND SEPARATORS IN THE NATURE OF BLOOD, BIOLOGICAL FLUID, TISSUE AND/OR CELL COMPONENT SEPARATION AND CONCENTRATION APPARATUS FOR MEDICAL USE; BLOOD OR BIOLOGICAL FLUID FILTERS FOR MEDICAL USE; MEDICAL DEVICES, NAMELY, BIOLOGICAL AND CHEMICAL FLUID AND MATERIAL TRANSFER DEVICES FOR THE TRANSFER OF FLUID AND MATERIALS FROM A NON-STERILE FIELD TO A STERILE FIELD IN THE NATURE OF COUPLERS FOR MEDICAL SYRINGES, TEST TUBES, SPECIMEN TUBES, IV TUBING AND PLASTIC BAGS FOR MEDICAL, BIOLOGICAL OR CHEMICAL FLUID AND MATERIAL TRANSFER (U.S. CLS. 26, 39 AND 44).

FIRST USE 1-25-2011; IN COMMERCE 1-25-2011.

**CLASS 38—COMMUNICATION**

FOR PROVIDING REMOTE INTERNET ACCESS TO ELECTRONIC FILES STORED IN AN INTERNET SERVER OR CLOUD; ELECTRONIC EXCHANGE OF DATA STORED IN DATABASES ACCESSIBLE OVER TELECOMMUNICATION NETWORKS; BROADCASTING SERVICES AND PROVISION OF TELECOMMUNICATION ACCESS TO FILMS AND TELEVISION PROGRAMS PROVIDED VIA A VIDEO-ON-DEMAND SERVICE; TRANSMISSION OF DATABASE INFORMATION OVER TELECOMMUNICATION NETWORKS FROM A COMPUTER STORED DATABANK (U.S. CLS. 100, 101 AND 104).

FIRST USE 1-16-2009; IN COMMERCE 1-16-2009.

3,941,159. PAYLESS SHOESOURCE WORLDWIDE, INC., TOPEKA, KS. SN 77-610,751. PUB. 10-6-2009, FILED 11-10-2008.

**PAYLESS GIVES.**

THE MARK CONSISTS OF STANDARD CHARACTERS WITHOUT CLAIM TO ANY PARTICULAR FONT, STYLE, SIZE, OR COLOR.

OWNER OF U.S. REG. NOS. 1,837,194, 1,949,546, AND OTHERS.

**CLASS 35—ADVERTISING AND BUSINESS**

FOR CHARITABLE SERVICES, NAMELY, PROVIDING GIFT CERTIFICATES FOR THE PURCHASE OF SHOES TO CHILDREN THROUGH NON-PROFIT ORGANIZATIONS (U.S. CLS. 100, 101 AND 102).

FIRST USE 12-0-2008; IN COMMERCE 12-0-2008.

**CLASS 45—PERSONAL AND LEGAL SERVICES**

FOR CHARITABLE SERVICES, NAMELY, PROVIDING SHOES TO CHILDREN THROUGH NON-PROFIT ORGANIZATIONS (U.S. CLS. 100 AND 101).

FIRST USE 12-0-2008; IN COMMERCE 12-0-2008.

3,941,167. ZECTER, INC., SAN MATEO, CA. SN 77-620,302. PUB. 10-6-2009, FILED 11-23-2008.

**zumodrive**

THE MARK CONSISTS OF STANDARD CHARACTERS WITHOUT CLAIM TO ANY PARTICULAR FONT, STYLE, SIZE, OR COLOR.

**CLASS 39—TRANSPORTATION AND STORAGE**

FOR ELECTRONIC DATA STORAGE SERVICES, NAMELY, PROVIDING A VIRTUAL DISK DRIVE VIA A GLOBAL COMPUTER NETWORK FOR STORAGE OF ELECTRONIC FILES; PROVIDING ELECTRONIC DATA STORAGE FOR PORTABLE MEDIA PLAYERS AND SMART PHONES; ELECTRONIC DATA STORAGE SERVICES, NAMELY, PROVIDING AN ONLINE REPOSITORY FOR STORING ELECTRONIC DATA; PROVIDING ONLINE STORAGE OF ELECTRONIC DATA (U.S. CLS. 100 AND 105).

FIRST USE 1-16-2009; IN COMMERCE 1-16-2009.

**CLASS 42—SCIENTIFIC AND COMPUTER SERVICES**

FOR PROVIDING ONLINE, NON-DOWNLOADABLE FILE SHARING COMPUTER SOFTWARE FOR ENABLING MULTIPLE USERS TO SHARE AND WORK ON A FILE, MAINTAIN VERSION CONTROL OF A FILE, CACHE RECENTLY USED FILES, MAINTAIN ACCESS CONTROL FOR A FILE, MODIFY ACCESS PRIVILEGES, AND TRACK FILE SHARING AND ACCESS; SEARCHING AND RETRIEVING DATA, IMAGES, AUDIO AND/OR VIDEO INFORMATION ON COMPUTER DATABASES FOR OTHERS; PROVIDING ONLINE, NON-DOWNLOADABLE COMPUTER SOFTWARE FOR VIEWING FILES AND DOCUMENTS IN A WEB BROWSER THAT ARE STORED IN AN INTERNET SERVER OR CLOUD; PROVIDING ONLINE, NON-DOWNLOADABLE COMPUTER SOFTWARE FOR ACCESSING ONLINE OR VIA A DESKTOP COMPUTER FILES STORED IN AN INTERNET SERVER OR CLOUD; PROVIDING ONLINE, NON-DOWNLOADABLE COMPUTER SOFTWARE FOR STREAMING FILES FROM AN INTERNET SERVER OR CLOUD TO A LOCAL CACHE IN A LOCAL COMPUTER; PROVIDING ONLINE, NON-DOWNLOADABLE COMPUTER SOFTWARE FOR DELETING FILES STORED IN AN INTERNET SERVER OR CLOUD; PROVIDING ONLINE, NON-DOWNLOADABLE COMPUTER SOFTWARE FOR SENDING NOTIFICATIONS RELATED TO A FILE UPDATE; REMOTE, ONLINE COMPUTER BACKUP SERVICES; PROVIDING ONLINE, NON-DOWNLOADABLE COMPUTER SOFTWARE FOR ACCESSING FILES STORED IN AN INTERNET SERVER OR CLOUD FROM A DESKTOP COMPUTER OR FROM A GLOBAL COMPUTER NETWORK; PROVIDING ONLINE, NON-DOWNLOADABLE COMPUTER SOFTWARE FOR DETERMINING INTELLIGENTLY WHICH DOCUMENTS TO KEEP LOCALLY BASED ON ACTIVITY OF THE USER AND THE AMOUNT OF SHARING AND WORK DONE ON A FILE; PROVIDING ONLINE, NON-DOWNLOADABLE COMPUTER SOFTWARE FOR VIEWING FILES AND DOCUMENTS STORED ON A STORAGE CLOUD IN A TELECOMMUNICATIONS NETWORK (U.S. CLS. 100 AND 101).

FIRST USE 1-16-2009; IN COMMERCE 1-16-2009.

3,941,168. NAME RITE, L.L.C., TEMECULA, CA. SN 77-620,436. PUB. 11-3-2009, FILED 11-24-2008.



OWNER OF U.S. REG. NOS. 2,709,892, 3,477,992, AND OTHERS.

NO CLAIM IS MADE TO THE EXCLUSIVE RIGHT TO USE "FOR PARENTS", APART FROM THE MARK AS SHOWN.

THE MARK CONSISTS OF THE TERMS "GIVING CARE FOR PARENTS" WITH THE TERMS "RITE AID" IN A SHIELD DEVICE.

#### **CLASS 9—ELECTRICAL AND SCIENTIFIC APPARATUS**

FOR DOWNLOADABLE VIDEO RECORDINGS AND ELECTRONIC PUBLICATIONS IN THE NATURE OF A SERIES OF ARTICLES ALL IN THE FIELD OF HEALTH AND WELLNESS (U.S. CLS. 21, 23, 26, 36 AND 38).

FIRST USE 8-31-2008; IN COMMERCE 8-31-2008.

#### **CLASS 35—ADVERTISING AND BUSINESS**

FOR RETAIL PHARMACY SERVICES; PROVIDING A WEB SITE FEATURING CONSUMER INFORMATION IN THE HEALTH AND WELLNESS FIELDS IN THE FORM OF VIDEO INTERVIEWS, ARTICLES AND OTHER EDUCATIONAL MATERIALS; PROMOTING THE GOODS AND SERVICES OF OTHERS, NAMELY, THROUGH THE DISTRIBUTION OF COUPONS, REBATE INFORMATION, AND DISCOUNT CARDS (U.S. CLS. 100, 101 AND 102).

FIRST USE 8-31-2008; IN COMMERCE 8-31-2008.

#### **CLASS 38—COMMUNICATION**

FOR PROVIDING ON-LINE FORUMS FOR TRANSMISSION OF MESSAGES AMONG COMPUTER USERS CONCERNING HEALTH AND WELLNESS TOPICS; PROVIDING INTERNET CHATROOMS (U.S. CLS. 100, 101 AND 104).

FIRST USE 8-31-2008; IN COMMERCE 8-31-2008.

#### **CLASS 44—MEDICAL, BEAUTY AND AGRICULTURAL SERVICES**

FOR PROVIDING A WEB SITE FEATURING INFORMATION REGARDING HEALTH AND WELLNESS IN THE FORM OF VIDEO INTERVIEWS, ARTICLES, AND OTHER EDUCATIONAL MATERIALS; PROVIDING INFORMATION IN THE FIELD OF HEALTH AND WELLNESS (U.S. CLS. 100 AND 101).

FIRST USE 8-31-2008; IN COMMERCE 8-31-2008.

3,941,178. GREEN HOME PRINCIPLES LLC, AKA GREEN-STEPS LLC, PHILADELPHIA, PA. SN 77-633,834. PUB. 4-14-2009, FILED 12-16-2008.

THE MARK CONSISTS OF STANDARD CHARACTERS

WITHOUT CLAIM TO ANY PARTICULAR FONT, STYLE, SIZE, OR COLOR.

#### **CLASS 41—EDUCATION AND ENTERTAINMENT**

FOR CONTINUING EDUCATION SERVICES, NAMELY, PROVIDING LIVE AND ON-LINE CONTINUING PROFESSIONAL EDUCATION SEMINARS IN THE FIELD OF SUSTAINABLE BUILDING PRACTICES (U.S. CLS. 100, 101 AND 107).

FIRST USE 9-25-2008; IN COMMERCE 11-1-2008.

#### **CLASS 42—SCIENTIFIC AND COMPUTER SERVICES**

FOR ARCHITECTURAL CONSULTANCY; ARCHITECTURAL CONSULTATION; CONSULTING IN THE FIELDS OF ENGINEERING AND ARCHITECTURE; CONSULTING SERVICES IN THE FIELD OF ARCHITECTURAL DESIGN (U.S. CLS. 100 AND 101).

FIRST USE 9-25-2008; IN COMMERCE 11-1-2008.

3,941,182. LANGER BIOMECHANICS, INC., DEER PARK, NY. SN 77-635,069. PUB. 10-20-2009, FILED 12-17-2008.

## LANGER BIOMECHANICS

THE MARK CONSISTS OF STANDARD CHARACTERS WITHOUT CLAIM TO ANY PARTICULAR FONT, STYLE, SIZE, OR COLOR.

OWNER OF U.S. REG. NOS. 1,274,226, 2,512,139, AND OTHERS.

NO CLAIM IS MADE TO THE EXCLUSIVE RIGHT TO USE "BIOMECHANICS", APART FROM THE MARK AS SHOWN.

SEC. 2(F) AS TO "LANGER".

#### **CLASS 10—MEDICAL APPARATUS**

FOR ORTHOTIC DEVICES FOR THE FEET AND ANKLES, NAMELY, INSERTS FOR SHOES AND AS A PROTECTIVE SUPPLEMENT FOR SOFT TISSUE ON BONY AREAS OF THE BODY SUCH AS FEET, ELBOWS, KNEES, ANKLES AND SHOULDERS, AND ORTHOTIC DEVICES FOR CORRECTION AND MANAGEMENT OF IN-TOE AND OUT-TOE DISORDERS IN CHILDREN (U.S. CLS. 26, 39 AND 44).

FIRST USE 0-0-1989; IN COMMERCE 0-0-1989.

#### **CLASS 44—MEDICAL, BEAUTY AND AGRICULTURAL SERVICES**

FOR ORTHOPEDIC SERVICES AND ORTHOPEDIC CONSULTING SERVICES RENDERED TO THE ORDER AND SPECIFICATIONS OF PODIATRISTS AND OTHER HEALTHCARE PROFESSIONALS RELATING TO ORTHOTICS (U.S. CLS. 100 AND 101).

FIRST USE 0-0-1989; IN COMMERCE 0-0-1989.

3,941,186. AMROAD TECHNOLOGY INC., TAIPEI COUNTY, TAIWAN. SN 77-642,419. PUB. 6-22-2010, FILED 1-1-2009.



THE COLOR(S) BLUE AND RED IS/ARE CLAIMED AS A FEATURE OF THE MARK.

THE MARK CONSISTS OF STYLIZED AND ITALICIZED LETTERS "AR" IN BLUE WITH A SOLID RED CIRCLE CENTERED ABOVE THE LETTERS.

#### CLASS 9—ELECTRICAL AND SCIENTIFIC APPARATUS

FOR TELECOMMUNICATION TRANSMITTERS; TRANSMITTERS OF ELECTRONIC SIGNALS; TELEPHONE APPARATUS; TELEPHONE RECEIVERS; TELEPHONE TRANSMITTERS; ELECTRIC LOCKS; INTERCOMMUNICATION APPARATUS, NAMELY, INTERCOMS, CELLULAR PHONES, DOOR-PHONES; DOWNLOADABLE ELECTRONIC PUBLICATIONS IN THE NATURE OF NEWSLETTERS, BOOKS, MAGAZINE IN THE FIELD OF MEDICAL CARE AND FOOD INDUSTRY; CAMCORDERS; VIDEO CAMERAS; VIDEO MONITORS; VIDEO PHONES; VIDEO TRANSMISSION APPARATUS; ELECTRONIC LOCKS; COMMUNICATIONS SERVER HARDWARE; NETWORK ACCESS SERVER HARDWARE; COMPUTER NETWORK ADAPTERS; COMPUTER NETWORK HUBS, SWITCHES AND ROUTERS; COMPUTER NETWORKING HARDWARE; LOCAL AREA NETWORK HARDWARE; DOWNLOADABLE MUSICAL SOUND RECORDINGS; DIGITAL MUSIC DOWNLOADABLE VIA INTERNET; ELECTRONICALLY OPERATED HIGH SECURITY LOCK CYLINDERS; PERSONAL SECURITY ALARMS; SATELLITE TELEPHONES; MAGNETIC CARDS; MAGNETIC IDENTIFYING CARDS; MAGNETIC CODED CARD READERS; ELECTRONIC WARNING BELLS; COMPUTER WORKSTATIONS APPARATUS, NAMELY, COMPUTERS, COMPUTER CABLES AND PRINTERS; COMPUTER WORKSTATIONS COMPRISING COMPUTERS, COMPUTER CABLES, COMPUTER DOCKING STATION AND PRINTER (U.S. CLS. 21, 23, 26, 36 AND 38).

FIRST USE 1-12-2011; IN COMMERCE 1-12-2011.

#### CLASS 35—ADVERTISING AND BUSINESS

FOR IMPORT AND EXPORT AGENCIES; COMMERCIAL INFORMATION SERVICES VIA VIDEO-PHONE, NAMELY, PROVIDING PRODUCT PRICE LISTS, PRODUCT SPECIFICATIONS, AND COMPANY INFORMATION IN THE FIELD OF FOOD AND CLOTHING INDUSTRY; MANAGEMENT OF ELECTRONIC FILES; ELECTRONIC DATA SEARCH SERVICES VIA VIDEO-PHONE, NAMELY, PROVIDING AN SEARCHABLE COMMERCIAL INFORMATION DATABASE; DATA MANAGEMENT SERVICES FOR USE IN PATIENTS' MEDICAL INFORMATION, NAMELY, ELECTRONIC DATA COLLECTION AND MANAGEMENT OF PATIENTS' MEDICAL INFORMATION; RETAIL STORE SERVICES FEATURING TELECOMMUNICATIONS HARDWARE AND COMPUTER ELECTRONICS (U.S. CLS. 100, 101 AND 102).

FIRST USE 1-12-2011; IN COMMERCE 1-12-2011.

#### CLASS 42—SCIENTIFIC AND COMPUTER SERVICES

FOR CONSULTANCY SERVICES IN THE FIELD OF COMPUTER HARDWARE; CONVERSION OF PHYSICAL DOCUMENTS TO ELECTRONIC MEDIA; INDUSTRIAL DESIGN IN THE FIELD OF COMMUNICATION EQUIPMENT DESIGN; COMPUTER RENTAL SERVICES; SECURITY SERVICES FOR COMPUTER NETWORKS, NAMELY, PROVIDING SECURED ELECTRONIC TRANSACTION AND ANONYMITY FOR ELECTRONICALLY TRANSMITTED CREDIT CARD TRANSACTIONS; COMPUTER SECURITY SERVICE, NAMELY, RESTRICTING ACCESS TO AND BY COMPUTER NETWORKS TO AND OF UNDESIRED WEB SITES, MEDIA AND INDIVIDUALS AND FACILITIES (U.S. CLS. 100 AND 101).

FIRST USE 1-12-2011; IN COMMERCE 1-12-2011.

3,941,191. BRAV-WURLD, LLC, RENO, NV. SN 77-645,214. PUB. 4-28-2009, FILED 1-7-2009.

# SUNVELOPE

THE MARK CONSISTS OF STANDARD CHARACTERS WITHOUT CLAIM TO ANY PARTICULAR FONT, STYLE, SIZE, OR COLOR.

#### CLASS 11—ENVIRONMENTAL CONTROL APPARATUS

FOR SOLAR COLLECTORS (U.S. CLS. 13, 21, 23, 31 AND 34).

FIRST USE 8-0-2010; IN COMMERCE 8-0-2010.

#### CLASS 42—SCIENTIFIC AND COMPUTER SERVICES

FOR TECHNOLOGY PLANNING IN THE FIELD OF SOLAR ENERGY (U.S. CLS. 100 AND 101).

FIRST USE 8-0-2010; IN COMMERCE 8-0-2010.

3,941,196. ENVIRONMENTAL INDUSTRY ASSOCIATIONS, WASHINGTON, DC. SN 77-649,033. PUB. 6-8-2010, FILED 1-14-2009.



**Environmentalists.  
Every Day.**  
AMERICA'S SOLID WASTE INDUSTRY

NO CLAIM IS MADE TO THE EXCLUSIVE RIGHT TO USE "AMERICA'S SOLID WASTE INDUSTRY", APART FROM THE MARK AS SHOWN.

THE MARK CONSISTS OF A WASTE COLLECTION TRUCK COMPRISING A DESIGN OF A PORTION OF A LEAF ABOVE THE WORDING "ENVIRONMENTALISTS."

"EVERY DAY." "AMERICA'S SOLID WASTE INDUSTRY".

#### **CLASS 9—ELECTRICAL AND SCIENTIFIC APPARATUS**

FOR DOWNLOADABLE ELECTRONIC PUBLICATIONS IN THE NATURE OF MAGAZINES, BROCHURES, BOOKLETS, POSTERS, PAMPHLETS, AND NEWSLETTERS IN THE FIELDS OF SOLID, HAZARDOUS, AND MEDICAL WASTE COLLECTION, MANAGEMENT, RECYCLING, AND DISPOSAL, ENVIRONMENTAL ISSUES, AND WASTE AND POLLUTION; AUDIO AND VIDEO RECORDING FEATURING INFORMATION IN THE FIELDS OF SOLID, HAZARDOUS, AND MEDICAL WASTE COLLECTION, MANAGEMENT, RECYCLING, AND DISPOSAL, ENVIRONMENTAL ISSUES, AND WASTE AND POLLUTION; DOWNLOADABLE MULTIMEDIA PUBLICATIONS IN THE NATURE OF MAGAZINES, BROCHURES, BOOKLETS, POSTERS, PAMPHLETS, AND NEWSLETTERS IN THE FIELDS OF SOLID, HAZARDOUS, AND MEDICAL WASTE COLLECTION, MANAGEMENT, RECYCLING, AND DISPOSAL, ENVIRONMENTAL ISSUES, AND WASTE AND POLLUTION (U.S. CLS. 21, 23, 26, 36 AND 38).

FIRST USE 10-1-2008; IN COMMERCE 10-1-2008.

#### **CLASS 16—PAPER GOODS AND PRINTED MATTER**

FOR PRINTED PUBLICATIONS, NAMELY, MAGAZINES, BROCHURES, BOOKLETS, POSTERS, PAMPHLETS, AND NEWSLETTERS IN THE FIELDS OF SOLID, HAZARDOUS, AND MEDICAL WASTE COLLECTION, MANAGEMENT, RECYCLING, AND DISPOSAL, ENVIRONMENTAL ISSUES, AND WASTE AND POLLUTION; STICKERS, BUMPER STICKERS, AND DECALS (U.S. CLS. 2, 5, 22, 23, 29, 37, 38 AND 50).

FIRST USE 9-1-2009; IN COMMERCE 9-1-2009.

#### **CLASS 35—ADVERTISING AND BUSINESS**

FOR ASSOCIATION SERVICES, NAMELY, PROMOTING PUBLIC AWARENESS AND THE INTERESTS OF THE SOLID, HAZARDOUS, AND MEDICAL WASTE COLLECTION, MANAGEMENT, RECYCLING, AND DISPOSAL, AND WASTE AND POLLUTION INDUSTRIES (U.S. CLS. 100, 101 AND 102).

FIRST USE 10-1-2008; IN COMMERCE 10-1-2008.

#### **CLASS 37—CONSTRUCTION AND REPAIR**

FOR PROVIDING NEWS AND INFORMATION IN THE FIELDS OF SOLID, HAZARDOUS, AND MEDICAL WASTE COLLECTION AND DISPOSAL; PROVIDING A WEBSITE FEATURING NEWS AND INFORMATION IN THE FIELDS OF SOLID, HAZARDOUS, AND MEDICAL WASTE COLLECTION AND DISPOSAL (U.S. CLS. 100, 103 AND 106).

FIRST USE 10-1-2008; IN COMMERCE 10-1-2008.

#### **CLASS 40—MATERIAL TREATMENT**

FOR PROVIDING NEWS AND INFORMATION IN THE FIELD OF SOLID, HAZARDOUS, AND MEDICAL WASTE RECYCLING AND WASTE MANAGEMENT; PROVIDING A WEBSITE FEATURING NEWS AND INFORMATION IN THE FIELD OF SOLID, HAZARDOUS, AND MEDICAL WASTE RECYCLING AND WASTE MANAGEMENT (U.S. CLS. 100, 103 AND 106).

FIRST USE 10-1-2008; IN COMMERCE 10-1-2008.

#### **CLASS 41—EDUCATION AND ENTERTAINMENT**

FOR PROVIDING ONLINE NON-DOWNLOADABLE ELECTRONIC PUBLICATIONS IN THE NATURE OF MAGAZINES, BROCHURES, BOOKLETS, PAMPHLETS, AND NEWSLETTERS IN THE FIELDS OF SOLID, HAZARDOUS, AND MEDICAL WASTE COLLECTION, MANAGEMENT, RECYCLING, AND DISPOSAL, ENVIRONMENTAL ISSUES, AND WASTE AND POLLUTION (U.S. CLS. 100, 101 AND 107).

FIRST USE 10-1-2008; IN COMMERCE 10-1-2008.

3,941,199. GILBERT, JANELLE, CHICAGO, IL. SN 77-651,229. PUB. 5-25-2010, FILED 1-16-2009.



THE NAME "JANELLE" IDENTIFIES A LIVING INDIVIDUAL WHOSE CONSENT IS OF RECORD.

THE MARK CONSISTS OF THE NAME "JANELLE" AND HER SIGNATURE.

#### **CLASS 9—ELECTRICAL AND SCIENTIFIC APPARATUS**

FOR SERIES OF MUSICAL SOUND RECORDINGS AND MUSICAL VIDEO RECORDINGS (U.S. CLS. 21, 23, 26, 36 AND 38).

FIRST USE 3-30-2008; IN COMMERCE 3-30-2008.

#### **CLASS 41—EDUCATION AND ENTERTAINMENT**

FOR ENTERTAINMENT SERVICES IN THE NATURE OF LIVE MUSICAL AND VOCAL PERFORMANCES BY A SOLO RECORDING ARTIST (U.S. CLS. 100, 101 AND 107).

FIRST USE 3-30-2008; IN COMMERCE 3-30-2008.

3,941,222. TRI-FOCUS WEALTH MANAGEMENT GROUP, INC., CALIMESA, CA. SN 77-668,299. PUB. 6-9-2009, FILED 2-11-2009.

# TRI-FOCUS

THE MARK CONSISTS OF STANDARD CHARACTERS WITHOUT CLAIM TO ANY PARTICULAR FONT, STYLE, SIZE, OR COLOR.

#### **CLASS 35—ADVERTISING AND BUSINESS**

FOR BOOKKEEPING; INCOME TAX PREPARATION; INCOME TAX CONSULTATION; TAX ADVISORY SERVICES; TAX FILING SERVICES; TAX PREPARATION; BUSINESS CONSULTING, MANAGEMENT, PLANNING AND SUPERVISION (U.S. CLS. 100, 101 AND 102).

FIRST USE 8-2-2010; IN COMMERCE 8-2-2010.



**CLASS 36—INSURANCE AND FINANCIAL**

FOR FINANCIAL PLANNING AND INVESTMENT ADVISORY SERVICES; INSURANCE SERVICES, NAMELY, UNDERWRITING LIFE AND HEALTH INSURANCE (U.S. CLS. 100, 101 AND 102).  
FIRST USE 8-2-2010; IN COMMERCE 8-2-2010.

3,941,228. PROHERANT HEALTH, INC., OVERLAND PARK, KS. SN 77-678,125. PUB. 8-24-2010, FILED 2-25-2009.

PROHERANT

THE MARK CONSISTS OF STANDARD CHARACTERS WITHOUT CLAIM TO ANY PARTICULAR FONT, STYLE, SIZE, OR COLOR.

**CLASS 35—ADVERTISING AND BUSINESS**

FOR OPERATION OF TELEPHONE CALL CENTERS FOR OTHERS; MEDICAL BILLING SUPPORT SERVICES, NAMELY, IDENTIFYING COVERAGE FOR PRESCRIBED THERAPIES, INSURANCE BENEFITS INVESTIGATIONS, CLAIMS ASSISTANCE, AND PRIOR AUTHORIZATION AND APPEAL SUPPORT TO PHYSICIANS ADMINISTERING DRUGS IN THEIR OFFICES, AND PATIENT AND CARETAKER SUPPORT AND ASSISTANCE PROGRAMS TO PROVIDE GUIDANCE THROUGH COMPLEX INSURANCE REIMBURSEMENT PROCESSES (U.S. CLS. 100, 101 AND 102).  
FIRST USE 12-8-2009; IN COMMERCE 12-8-2009.

**CLASS 41—EDUCATION AND ENTERTAINMENT**

FOR PROVIDING PATIENT EDUCATIONAL SERVICES, NAMELY, CONDUCTING PROGRAMS IN THE FIELD OF CHRONIC DISEASES, PROPER PRODUCT-RESTITUTION AND ADMINISTRATION, AND RESOURCES APPROPRIATE FOR SUPPORT OF DISEASE MANAGEMENT; EDUCATIONAL SERVICES FOR PRODUCT MANUFACTURERS, BIOTECH COMPANIES, CLINICIANS, AND INSURANCE PROVIDERS, NAMELY, CONDUCTING CLASSES, ONE-ON-ONE SESSIONS IN THE FIELD OF CHRONIC DISEASES, PROPER PRODUCT-RESTITUTION AND ADMINISTRATION, AND RESOURCES APPROPRIATE FOR SUPPORT OF DISEASE MANAGEMENT AND DISTRIBUTING COURSE MATERIALS IN CONNECTION THEREWITH; EDUCATIONAL SERVICES, NAMELY, CONDUCTING CLASSES, ONE-ON-ONE SESSIONS AND TELEPHONIC WORKSHOPS WHICH PROVIDE PHYSICIANS, INSURANCE COMPANIES AND PATIENTS WITH SPECIFIC CHARACTERISTICS ASSOCIATED WITH DISEASE MANAGEMENT PRODUCTS (U.S. CLS. 100, 101 AND 107).  
FIRST USE 12-8-2009; IN COMMERCE 12-8-2009.

**CLASS 42—SCIENTIFIC AND COMPUTER SERVICES**

FOR PROVIDING CLINICAL RESEARCH SUPPORT IN THE FIELD OF MEDICINE FOR PRODUCT MANUFACTURERS, PHARMACEUTICAL AND BIOTECH COMPANIES, CONTRACT RESEARCH ORGANIZATIONS AND INSURANCE PROVIDERS, AND PRODUCT DEVELOPMENT CONSULTATION IN SUPPORT OF NEW DRUG PRODUCT LAUNCHES (U.S. CLS. 100 AND 101).  
FIRST USE 12-8-2009; IN COMMERCE 12-8-2009.

3,941,263. JURLNNOV HOLDING LIMITED PARTNERSHIP, CLEVELAND, OH. SN 77-724,107. PUB. 6-22-2010, FILED 4-28-2009.

ESIBYTES

THE MARK CONSISTS OF STANDARD CHARACTERS WITHOUT CLAIM TO ANY PARTICULAR FONT, STYLE, SIZE, OR COLOR.

**CLASS 41—EDUCATION AND ENTERTAINMENT**

FOR PUBLICATION OF ELECTRONIC EDUCATIONAL MATERIALS, NAMELY, PROVIDING PODCASTS, ELECTRONIC DATA FILES, PRESENTATIONS, INTERVIEW TRANSCRIPTS AND PUBLICATIONS, NAMELY, ARTICLES, IN THE FIELD OF ELECTRONIC LEGAL DISCOVERY; PUBLICATION OF ELECTRONIC EDUCATIONAL MATERIALS, NAMELY, ARTICLES AND BLOGS IN THE FIELD OF ELECTRONIC LEGAL DISCOVERY (U.S. CLS. 100, 101 AND 107).  
FIRST USE 3-0-2009; IN COMMERCE 3-0-2009.

**CLASS 42—SCIENTIFIC AND COMPUTER SERVICES**

FOR PROVIDING TECHNICAL CONSULTING SERVICES IN THE FIELD OF ELECTRONIC LEGAL DISCOVERY; COMPUTER SERVICES, NAMELY, HOSTING AN INTERACTIVE WEB SITE THAT ALLOWS USERS TO READ, DOWNLOAD AND SCHEDULE THE USE OR REVIEW OF ELECTRONIC EDUCATIONAL MATERIALS IN THE FIELD OF ELECTRONIC LEGAL DISCOVERY; COMPUTER SERVICES, NAMELY, PROVIDING SEARCH ENGINES FOR OBTAINING ELECTRONIC EDUCATIONAL MATERIALS IN THE FIELD OF ELECTRONIC LEGAL DISCOVERY ON A GLOBAL COMPUTER NETWORK; COMPUTER SERVICES, NAMELY, HOSTING AN INTERACTIVE WEB SITE THAT ALLOWS USERS TO UPLOAD ELECTRONIC EDUCATIONAL MATERIALS IN THE FIELD OF ELECTRONIC LEGAL DISCOVERY (U.S. CLS. 100 AND 101).  
FIRST USE 3-0-2009; IN COMMERCE 3-0-2009.

3,941,271. HOFFMASTER GROUP, INC., OSHKOSH, WI. SN 77-736,383. PUB. 4-20-2010, FILED 5-13-2009.

CELEBRATIONS BY CREATIVE  
CONVERTING

THE MARK CONSISTS OF STANDARD CHARACTERS WITHOUT CLAIM TO ANY PARTICULAR FONT, STYLE, SIZE, OR COLOR.

NO CLAIM IS MADE TO THE EXCLUSIVE RIGHT TO USE "CONVERTING", APART FROM THE MARK AS SHOWN.

**CLASS 16—PAPER GOODS AND PRINTED MATTER**

FOR PAPER NAPKINS; PAPER PARTY DECORATION; PAPER PARTY FAVORS; DECORATIVE PAPER CENTERPIECES (U.S. CLS. 2, 5, 22, 23, 29, 37, 38 AND 50).  
FIRST USE 8-0-2009; IN COMMERCE 8-0-2009.

**CLASS 20—FURNITURE AND ARTICLES NOT OTHERWISE CLASSIFIED**

FOR PLASTIC BANNER (U.S. CLS. 2, 13, 22, 25, 32 AND 50).

FIRST USE 8-0-2009; IN COMMERCE 8-0-2009.

**CLASS 21—HOUSEWARES AND GLASS**

FOR PAPER PLATES (U.S. CLS. 2, 13, 23, 29, 30, 33, 40 AND 50).

FIRST USE 8-0-2009; IN COMMERCE 8-0-2009.

**CLASS 24—FABRICS**

FOR PLASTIC TABLE COVERS (U.S. CLS. 42 AND 50).

FIRST USE 8-0-2009; IN COMMERCE 8-0-2009.

**CLASS 28—TOYS AND SPORTING GOODS**

FOR PARTY FAVORS IN THE NATURE OF SMALL TOYS (U.S. CLS. 22, 23, 38 AND 50).

FIRST USE 8-0-2009; IN COMMERCE 8-0-2009.

3,941,280. PASTFUTURE, INC., NEW YORK, NY. SN 77-745,488. PUB. 12-22-2009, FILED 5-27-2009.

**PASTFUTURE**

THE MARK CONSISTS OF STANDARD CHARACTERS WITHOUT CLAIM TO ANY PARTICULAR FONT, STYLE, SIZE, OR COLOR.

**CLASS 35—ADVERTISING AND BUSINESS**

FOR PROVIDING A DATABASE OF CONSUMER ELECTRONICS INFORMATION PERTAINING TO REVIEWS AND DISCUSSIONS OF SAME; PROVIDING CONSUMER PRODUCT INFORMATION, NAMELY, SPECIFICATION INFORMATION ON CONSUMER ELECTRONICS; PROVIDING CONSUMER ELECTRONICS INFORMATION AND RELATED NEWS VIA A WEBSITE; AND PROVIDING CONSUMER PRODUCT INFORMATION AND RELATED NEWS IN THE FIELD OF CONSUMER ELECTRONICS VIA A WEBSITE (U.S. CLS. 100, 101 AND 102).

FIRST USE 7-1-2009; IN COMMERCE 7-1-2009.

**CLASS 41—EDUCATION AND ENTERTAINMENT**

FOR PROVIDING ARTICLES FEATURING EDITORIALS AND OPINIONS ON CONSUMER ELECTRONICS VIA A GLOBAL COMPUTER NETWORK (U.S. CLS. 100, 101 AND 107).

FIRST USE 7-1-2009; IN COMMERCE 7-1-2009.

3,941,286. BOOMERDOLLS, LLC, PHOENIX, AZ. SN 77-753,014. PUB. 5-25-2010, FILED 6-5-2009.

**SWEATY-BETTY**

THE MARK CONSISTS OF STANDARD CHARACTERS WITHOUT CLAIM TO ANY PARTICULAR FONT, STYLE, SIZE, OR COLOR.

**CLASS 5—PHARMACEUTICALS**

FOR PACKAGED KITS COMPOSED PRIMARILY OF A WATER-BASED HERBAL SPRAY, A PILLOW FILLED WITH DRIED HERBS, A CLOTH WRAP AND PRINTED INSTRUCTIONAL MATERIALS. ALL FOR USE BY MENOPAUSAL WOMEN FOR THE SYMPTOMATIC RELIEF OF THE EFFECTS OF MENOPAUSE (U.S. CLS. 6, 18, 44, 46, 51 AND 52).

FIRST USE 1-11-2011; IN COMMERCE 1-11-2011.

**CLASS 35—ADVERTISING AND BUSINESS**

FOR ON-LINE RETAIL STORE SERVICES FEATURING PACKAGED KITS COMPOSED PRIMARILY OF A WATER-BASED HERBAL SPRAY, A PILLOW FILLED WITH DRIED HERBS, A CLOTH WRAP AND PRINTED INSTRUCTIONAL MATERIALS. ALL FOR USE BY MENOPAUSAL WOMEN FOR THE SYMPTOMATIC RELIEF OF THE EFFECTS OF MENOPAUSE (U.S. CLS. 100, 101 AND 102).

FIRST USE 1-11-2011; IN COMMERCE 1-11-2011.

3,941,287. BOOMERDOLLS, LLC, PHOENIX, AZ. SN 77-753,029. PUB. 5-25-2010, FILED 6-5-2009.



THE MARK CONSISTS OF IMAGE OF HEAD OF A FEMALE APPEARING TO BE SWEATING.

**CLASS 5—PHARMACEUTICALS**

FOR PACKAGED KITS COMPOSED PRIMARILY OF A WATER-BASED HERBAL SPRAY, A PILLOW FILLED WITH DRIED HERBS, A CLOTH WRAP AND PRINTED INSTRUCTIONAL MATERIALS. ALL FOR USE BY MENOPAUSAL WOMEN FOR THE SYMPTOMATIC RELIEF OF THE EFFECTS OF MENOPAUSE (U.S. CLS. 6, 18, 44, 46, 51 AND 52).

FIRST USE 1-11-2011; IN COMMERCE 1-11-2011.

**CLASS 35—ADVERTISING AND BUSINESS**

FOR ON-LINE RETAIL STORE SERVICES FEATURING PACKAGED KITS COMPOSED PRIMARILY OF A WATER-BASED HERBAL SPRAY, A PILLOW FILLED WITH DRIED HERBS, A CLOTH WRAP AND PRINTED INSTRUCTIONAL MATERIALS, ALL FOR USE BY MENOPAUSAL WOMEN FOR THE SYMPTOMATIC RELIEF OF THE EFFECTS OF MENOPAUSE (U.S. CLS. 100, 101 AND 102).

FIRST USE 1-11-2011; IN COMMERCE 1-11-2011.

3,941,290. PUJOL, JAIME, MIAMI, FL. SN 77-753,954. PUB. 5-25-2010, FILED 6-7-2009.

**UNSINKABLE STARS AND STRIPES**

THE MARK CONSISTS OF STANDARD CHARACTERS WITHOUT CLAIM TO ANY PARTICULAR FONT, STYLE, SIZE, OR COLOR.

**CLASS 24—FABRICS**

FOR CLOTH BANNERS (U.S. CLS. 42 AND 50).  
FIRST USE 12-7-2010; IN COMMERCE 12-7-2010.

3,941,289. SERVANTHOOD, INC., LAURELTON, NY. SN 77-753,801. PUB. 6-8-2010, FILED 6-6-2009.

**CLASS 41—EDUCATION AND ENTERTAINMENT**

FOR ENTERTAINMENT IN THE NATURE OF AIR SHOWS; ENTERTAINMENT IN THE NATURE OF TELEVISION NEWS SHOWS; ENTERTAINMENT IN THE NATURE OF VISUAL AND AUDIO PERFORMANCES, AND MUSICAL, VARIETY, NEWS AND COMEDY SHOWS; ENTERTAINMENT IN THE NATURE OF VISUAL AND AUDIO PERFORMANCES, NAMELY, MUSICAL BAND, ROCK GROUP, GYMNASTIC, DANCE, AND BALLET PERFORMANCES; ENTERTAINMENT IN THE NATURE OF YACHT RACES (U.S. CLS. 100, 101 AND 107).

FIRST USE 1-20-2011; IN COMMERCE 1-20-2011.



THE MARK CONSISTS OF THE STYLIZED WORD "GAMECHANGER".

**CLASS 18—LEATHER GOODS**

FOR BAGS FOR GENERAL AND SPORTS USE, NAMELY, ATHLETIC BAGS, HAND BAGS, OVERNIGHT BAGS, DUFFEL BAGS, TRUNKS, SUITCASES, AND TRAVELING BAGS (U.S. CLS. 1, 2, 3, 22 AND 41).  
FIRST USE 1-25-2011; IN COMMERCE 1-25-2011.

3,941,293. IFORMATA LLC, DAYTON, OH. SN 77-755,528. PUB. 10-27-2009, FILED 6-9-2009.

**CLASS 28—TOYS AND SPORTING GOODS**

FOR SPORTING GOODS, NAMELY, BALLS FOR PLAYING SPORTS; BAR-BELLS, FREE WEIGHTS, BASEBALL BATS; BASEBALL BATTING GLOVES; BASEBALL GLOVES; BASEBALL CATCHERS' MASKS; BASEBALLS; BASKETBALLS; BASKETBALL BASKETS; BASKETBALL HOOPS; SOCCER BALLS; TWIRLING BATONS; STATIONERY EXERCISE BICYCLES; BOWLING BALLS; FOOTBALLS; FOOTBALL KNEE PADS; FENCING ARTICLES, NAMELY, FENCING MASKS, AND EPEES; FENCING FOILS; FENCING GAUNTLETS; HOCKEY STICKS; HOCKEY SKATES; HOCKEY GOALIE EQUIPMENT, NAMELY, GOALIE PADS; HOCKEY GLOVES; FIGURE ICE SKATES; GYMNASTICS EQUIPMENT, NAMELY, PARALLEL BARS AND BALANCE BEAMS.; YOGA EQUIPMENT, NAMELY, PERSONAL YOGA MATS; TOYS AND GAMES, NAMELY, BOARD GAMES, TOY ACTION FIGURE DOLLS, TOY GUNS AND TOY SWORDS, ARCADE GAMES (U.S. CLS. 22, 23, 38 AND 50).

FIRST USE 1-25-2011; IN COMMERCE 1-25-2011.

**VNOC IN A BOX**

THE MARK CONSISTS OF STANDARD CHARACTERS WITHOUT CLAIM TO ANY PARTICULAR FONT, STYLE, SIZE, OR COLOR.

NO CLAIM IS MADE TO THE EXCLUSIVE RIGHT TO USE "VNOC", APART FROM THE MARK AS SHOWN.

**CLASS 38—COMMUNICATION**

FOR VIDEO, AUDIO AND DATA CONFERENCING SERVICES (U.S. CLS. 100, 101 AND 104).  
FIRST USE 6-17-2010; IN COMMERCE 6-17-2010.

**CLASS 32—LIGHT BEVERAGES**

FOR NON-ALCOHOLIC BEVERAGES, NAMELY, DRINKING WATER AND FLAVORED DRINKING WATER ENHANCED WITH VITAMINS (U.S. CLS. 45, 46 AND 48).

FIRST USE 1-25-2011; IN COMMERCE 1-25-2011.

**CLASS 42—SCIENTIFIC AND COMPUTER SERVICES**

FOR AUTOMATED MONITORING SERVICES, NAMELY, MONITORING THE STATUS OF AUDIO, VIDEO AND DATA NETWORK DEVICES RELATING TO SUPPORTING THE AUDIO, VIDEO AND DATA CONFERENCE OR COMMUNICATION FOR TECHNICAL PURPOSES (U.S. CLS. 100 AND 101).

FIRST USE 6-17-2010; IN COMMERCE 6-17-2010.

3,941,297. THF EQUITIES, LP, WESTCHESTER, IL. SN 77-756,787. PUB. 6-1-2010, FILED 6-10-2009.

3,941,300. LIVE IT EVERYDAY, LLC, LEXINGTON, KY. SN 77-758,572. PUB. 11-17-2009, FILED 6-12-2009.

## SCHWARTZ'S

THE MARK CONSISTS OF STANDARD CHARACTERS WITHOUT CLAIM TO ANY PARTICULAR FONT, STYLE, SIZE, OR COLOR.

OWNER OF U.S. REG. NOS. 1,059,439, 1,322,380, AND 1,642,932.  
SEC. 2(F).

### CLASS 29—MEATS AND PROCESSED FOODS

FOR PICKLES; SAUERKRAUT; PROCESSED PEPPERS (U.S. CL. 46).  
FIRST USE 12-31-1950; IN COMMERCE 12-31-1950.

### CLASS 30—STAPLE FOODS

FOR RELISH (U.S. CL. 46).  
FIRST USE 1-31-2010; IN COMMERCE 1-31-2010.

## LIVE IT EVERYDAY

THE MARK CONSISTS OF STANDARD CHARACTERS WITHOUT CLAIM TO ANY PARTICULAR FONT, STYLE, SIZE, OR COLOR.

### CLASS 25—CLOTHING

FOR CLOTHING, NAMELY, T-SHIRTS, BLOUSES, GOLF SHIRTS, BUTTON DOWN SHIRTS, PANTS, SHORT PANTS, SOCKS, HATS, BANDANAS, JACKETS, COATS, HOODED SWEATSHIRTS, BABY ONE PIECE PLAY SUITS, CLOTH BIBS, UNDERWEAR (U.S. CLS. 22 AND 39).  
FIRST USE 2-3-2011; IN COMMERCE 2-3-2011.

### CLASS 35—ADVERTISING AND BUSINESS

FOR ONLINE RETAIL STORE SERVICES FEATURING CLOTHING AND CLOTHING ACCESSORIES (U.S. CLS. 100, 101 AND 102).  
FIRST USE 2-3-2011; IN COMMERCE 2-3-2011.

3,941,299. HASIE CORPORATION, SAN MARCOS, CA. SN 77-758,394. PUB. 5-18-2010, FILED 6-12-2009.



THE MARK CONSISTS OF A PICTURE OF A MAN'S HEAD AND HANDS WITH THE WORDS "CRAZY" ABOVE AND "HAZY" BELOW.

### CLASS 25—CLOTHING

FOR CLOTHING, NAMELY, T-SHIRTS, SHORTS, HATS, PANTS, SHIRTS, DRESSES, JACKETS, SWEAT SHIRTS, SKIRTS (U.S. CLS. 22 AND 39).  
FIRST USE 11-15-2010; IN COMMERCE 11-15-2010.

### CLASS 29—MEATS AND PROCESSED FOODS

FOR BEEF JERKY; JERKY; SAUSAGE; DRIED BEEF; DRIED VEGETABLES; CHILI WITH OR WITHOUT BEANS; POTATO CRISPS AND CHIPS; PROCESSED PEPPERS; CANNED PROCESSED VEGETABLES (U.S. CL. 46).  
FIRST USE 11-15-2010; IN COMMERCE 11-15-2010.

3,941,313. ALLEGRO MFG. INC., COMMERCE, CO. SN 77-763,671. PUB. 11-3-2009, FILED 6-19-2009.

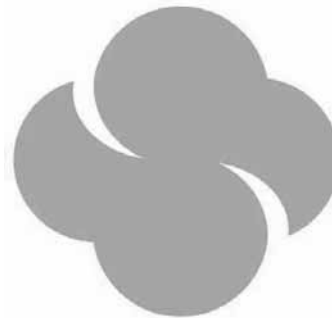

THE MARK CONSISTS OF A DESIGN OF A SOFT DIAMOND SHAPE WITH CIRCLES.

### CLASS 24—FABRICS

FOR BLANKET THROWS; PILLOW COVERS (U.S. CLS. 42 AND 50).  
FIRST USE 8-30-2009; IN COMMERCE 8-30-2009.

### CLASS 25—CLOTHING

FOR GLOVES; SLIPPERS; SOCKS (U.S. CLS. 22 AND 39).  
FIRST USE 8-30-2009; IN COMMERCE 8-30-2009.

### CLASS 28—TOYS AND SPORTING GOODS

FOR PLUSH TOYS (U.S. CLS. 22, 23, 38 AND 50).  
FIRST USE 8-30-2009; IN COMMERCE 8-30-2009.

3,941,314. KEVIN BOULTON, DOUGLASVILLE, GA. SN 77-763,676. PUB. 5-18-2010, FILED 6-19-2009.

## DOC HARMONY

THE MARK CONSISTS OF STANDARD CHARACTERS WITHOUT CLAIM TO ANY PARTICULAR FONT, STYLE, SIZE, OR COLOR.

OWNER OF U.S. REG. NO. 3,383,745.

"DOC HARMONY" IDENTIFIES THE NICKNAME OF HARMONY CONE, A LIVING INDIVIDUAL WHOSE CONSENT IS OF RECORD.

### CLASS 4—LUBRICANTS AND FUELS

FOR EAR CANDLES (U.S. CLS. 1, 6 AND 15).  
FIRST USE 10-0-2009; IN COMMERCE 10-0-2009.

### CLASS 5—PHARMACEUTICALS

FOR EAR OIL FOR TOPICAL USE, NAMELY, FOR THE TREATMENT OF DRY SKIN IN AND AROUND THE EAR (U.S. CLS. 6, 18, 44, 46, 51 AND 52).  
FIRST USE 10-0-2009; IN COMMERCE 10-0-2009.

3,941,315. BANC OF AMERICA COMMUNITY DEVELOPMENT CORPORATION, CHARLOTTE, NC. SN 77-763,802. PUB. 1-19-2010, FILED 6-19-2009.

## ENCORE! DOWNTOWN'S TEMPO DISTRICT

THE MARK CONSISTS OF STANDARD CHARACTERS WITHOUT CLAIM TO ANY PARTICULAR FONT, STYLE, SIZE, OR COLOR.

### CLASS 35—ADVERTISING AND BUSINESS

FOR PROMOTING THE BUSINESS, COMMUNITY, CULTURAL, HISTORIC, MUNICIPAL AND CIVIC INTERESTS OF TAMPA, FLORIDA; PROMOTING TOURISM, BUSINESS, RESIDENTIAL AND COMMERCIAL GROWTH, ECONOMIC DEVELOPMENT, CULTURAL AND HISTORIC ATTRACTIONS, AND GOVERNMENT SERVICES IN TAMPA, FLORIDA; PROVIDING COMMERCIAL DEMOGRAPHIC INFORMATION VIA A GLOBAL COMPUTER NETWORK ABOUT RESIDENTIAL AND COMMERCIAL GROWTH, ECONOMIC AND BUSINESS DEVELOPMENT SERVICES, CULTURAL AND HISTORIC ATTRACTIONS, AND GOVERNMENT SERVICES AND EMPLOYMENT OPPORTUNITIES IN TAMPA, FLORIDA (U.S. CLS. 100, 101 AND 102).  
FIRST USE 8-0-2009; IN COMMERCE 8-0-2009.

### CLASS 36—INSURANCE AND FINANCIAL

FOR REAL ESTATE LISTING; REAL ESTATE BROKERAGE; REAL ESTATE MANAGEMENT SERVICES; LEASING COMMERCIAL AND RETAIL SPACE TO OTHERS; SHOPPING CENTER SERVICES; PROVIDING INFORMATION RELATING TO REAL ESTATE LISTING, LEASING, MANAGEMENT, AND BROKERAGE SERVICES VIA THE INTERNET (U.S. CLS. 100, 101 AND 102).

FIRST USE 8-0-2009; IN COMMERCE 8-0-2009.

### CLASS 37—CONSTRUCTION AND REPAIR

FOR REAL ESTATE DEVELOPMENT SERVICES, NAMELY, PLANNING, LAYING OUT, AND CONSTRUCTION OF RESIDENTIAL AND COMMERCIAL PROPERTIES WITHIN A MULTI-USE COMMUNITY; PROVIDING INFORMATION RELATING TO REAL ESTATE DEVELOPMENT AND TO PLANNING AND LAYING OUT AND CONSTRUCTION OF RESIDENTIAL AND COMMERCIAL PROPERTIES WITHIN MULTI-USE COMMUNITY VIA THE INTERNET (U.S. CLS. 100, 103 AND 106).

FIRST USE 8-0-2009; IN COMMERCE 8-0-2009.

3,941,317. GSMA LTD., ATLANTA, GA. SN 77-763,954. PUB. 6-22-2010, FILED 6-19-2009.

## MOBILE WORLD LIVE

THE MARK CONSISTS OF STANDARD CHARACTERS WITHOUT CLAIM TO ANY PARTICULAR FONT, STYLE, SIZE, OR COLOR.

NO CLAIM IS MADE TO THE EXCLUSIVE RIGHT TO USE "MOBILE" FOR ALL CLASSES AND "LIVE" FOR CLASS 41, APART FROM THE MARK AS SHOWN.

### CLASS 35—ADVERTISING AND BUSINESS

FOR ADVERTISING SERVICES; BUSINESS DATA ANALYSIS OF TELECOMMUNICATIONS COMPANIES; PROVIDING BUSINESS INFORMATION ABOUT TELECOMMUNICATIONS COMPANIES (U.S. CLS. 100, 101 AND 102).

FIRST USE 7-15-2009; IN COMMERCE 7-15-2009.

### CLASS 38—COMMUNICATION

FOR TELECOMMUNICATIONS SERVICES, NAMELY, TRANSMISSION OF VOICE, DATA, GRAPHICS, IMAGES, AUDIO AND VIDEO; AUDIO AND VIDEO BROADCASTING SERVICES; PROVIDING INFORMATION IN THE FIELD OF TELECOMMUNICATIONS AND TELECOMMUNICATIONS SERVICES (U.S. CLS. 100, 101 AND 104).

FIRST USE 7-15-2009; IN COMMERCE 7-15-2009.

### CLASS 41—EDUCATION AND ENTERTAINMENT

FOR ENTERTAINMENT AND EDUCATIONAL SERVICES, NAMELY, PROVIDING ONLINE CLASSES, CONFERENCES, CONGRESSES, EXHIBITIONS, WEBINARS, SYMPOSIA AND WORKSHOPS IN THE FIELD OF TELECOMMUNICATIONS; ENTERTAINMENT SERVICES, NAMELY, PRODUCTION OF TELEVISION PROGRAMS; PROVIDING PODCASTS IN THE FIELD OF TELECOMMUNICATIONS; EDUCATIONAL SERVICES, NAMELY, ONLINE SEMINARS IN THE FIELD OF TELECOMMUNICATIONS (U.S. CLS. 100, 101 AND 107).  
FIRST USE 7-15-2009; IN COMMERCE 7-15-2009.

3,941,324. INFORMATIVE DESIGN GROUP, INC., DBA THE HISTORY FACTORY, CHANTILLY, VA. SN 77-766,791. PUB. 11-17-2009, FILED 6-24-2009.

**LUMINARC**

THE MARK CONSISTS OF STANDARD CHARACTERS WITHOUT CLAIM TO ANY PARTICULAR FONT, STYLE, SIZE, OR COLOR.

**CLASS 9—ELECTRICAL AND SCIENTIFIC APPARATUS**

FOR COMPUTER ARCHIVAL MANAGEMENT SOFTWARE PROGRAM FOR ANALYZING, CITING, ARCHIVING, TRANSFORMING, SUBSETTING, PRESERVING, SHARING, ACCESSING, SEARCHING, RETRIEVING, DOWNLOADING AND MANAGING ELECTRONIC RESEARCH DATA (U.S. CLS. 21, 23, 26, 36 AND 38).

FIRST USE 3-30-2009; IN COMMERCE 3-30-2009.

**CLASS 42—SCIENTIFIC AND COMPUTER SERVICES**

FOR PROVIDING TEMPORARY USE OF ONLINE NON-DOWNLOADABLE COMPUTER SOFTWARE FOR DIGITAL ARCHIVAL MANAGEMENT, NAMELY, PROGRAMS FOR ANALYZING, CITING, ARCHIVING, TRANSFORMING, SUBSETTING, PRESERVING, SHARING, ACCESSING, SEARCHING, RETRIEVING, DOWNLOADING AND MANAGING ELECTRONIC RESEARCH DATA (U.S. CLS. 100 AND 101).

FIRST USE 3-30-2009; IN COMMERCE 3-30-2009.

3,941,325. INFORMATIVE DESIGN GROUP, INC., DBA THE HISTORY FACTORY, CHANTILLY, VA. SN 77-766,820. PUB. 11-17-2009, FILED 6-24-2009.



THE MARK CONSISTS OF THE WORD "LUMINARC" WITH A SPOTLIGHTED OVAL ENCLOSED IN A RECTANGLE ABOVE AND TO THE RIGHT OF THE WORD.

**CLASS 9—ELECTRICAL AND SCIENTIFIC APPARATUS**

FOR COMPUTER ARCHIVAL MANAGEMENT SOFTWARE PROGRAM FOR ANALYZING, CITING, ARCHIVING, TRANSFORMING, SUBSETTING, PRESERVING, SHARING, ACCESSING, SEARCHING, RETRIEVING, DOWNLOADING AND MANAGING ELECTRONIC RESEARCH DATA (U.S. CLS. 21, 23, 26, 36 AND 38).

FIRST USE 3-30-2009; IN COMMERCE 3-30-2009.

**CLASS 42—SCIENTIFIC AND COMPUTER SERVICES**

FOR PROVIDING TEMPORARY USE OF ONLINE NON-DOWNLOADABLE COMPUTER SOFTWARE FOR DIGITAL ARCHIVAL MANAGEMENT, NAMELY, PROGRAMS FOR ANALYZING, CITING, ARCHIVING, TRANSFORMING, SUBSETTING, PRESERVING, SHARING, ACCESSING, SEARCHING, RETRIEVING, DOWNLOADING AND MANAGING ELECTRONIC RESEARCH DATA (U.S. CLS. 100 AND 101).

FIRST USE 3-30-2009; IN COMMERCE 3-30-2009.

3,941,326. INFORMATIVE DESIGN GROUP, INC., DBA THE HISTORY FACTORY, CHANTILLY, VA. SN 77-766,875. PUB. 11-24-2009, FILED 6-24-2009.



THE MARK CONSISTS OF THE WORDS "POWERED BY LUMINARC" FOLLOWED ON THE RIGHT WITH A SPOTLIGHTED OVAL ENCLOSED IN A RECTANGLE.

**CLASS 9—ELECTRICAL AND SCIENTIFIC APPARATUS**

FOR COMPUTER ARCHIVAL MANAGEMENT SOFTWARE PROGRAM FOR ANALYZING, CITING, ARCHIVING, TRANSFORMING, SUBSETTING, PRESERVING, SHARING, ACCESSING, SEARCHING, RETRIEVING, DOWNLOADING AND MANAGING ELECTRONIC RESEARCH DATA (U.S. CLS. 21, 23, 26, 36 AND 38).

FIRST USE 3-30-2009; IN COMMERCE 3-30-2009.

**CLASS 42—SCIENTIFIC AND COMPUTER SERVICES**

FOR PROVIDING TEMPORARY USE OF ONLINE NON-DOWNLOADABLE COMPUTER SOFTWARE FOR DIGITAL ARCHIVAL MANAGEMENT, NAMELY, PROGRAMS FOR ANALYZING, CITING, ARCHIVING, TRANSFORMING, SUBSETTING, PRESERVING, SHARING, ACCESSING, SEARCHING, RETRIEVING, DOWNLOADING AND MANAGING ELECTRONIC RESEARCH DATA (U.S. CLS. 100 AND 101).

FIRST USE 3-30-2009; IN COMMERCE 3-30-2009.

3,941,335. SCHOOL APPAREL, INC., BURLINGAME, CA. SN 77-771,512. PUB. 11-17-2009, FILED 6-30-2009.

**A+ CAREERWEAR**

THE MARK CONSISTS OF STANDARD CHARACTERS WITHOUT CLAIM TO ANY PARTICULAR FONT, STYLE, SIZE, OR COLOR.

**CLASS 25—CLOTHING**

FOR CLOTHING, NAMELY, CAREER, CASUAL, DRESS CODE, AND CUSTOM APPAREL COMPRISED OF SHIRTS, BLOUSES, OUTERWEAR, NAMELY, OVERSHIRTS, TURTLENECKS, SWEATERS, VESTS AND JACKETS; PANTS, TROUSERS, SLACKS, SHORTS, SKIRTS, JUMPERS, SKORTS, CULOTTES AND SOCKS; ACTIVE AND GYM WEAR, NAMELY, SWEATSHIRTS, SWEATPANTS, SHORTS, T-SHIRTS AND SOCKS (U.S. CLS. 22 AND 39).

FIRST USE 8-2-2010; IN COMMERCE 8-2-2010.

**CLASS 40—MATERIAL TREATMENT**

FOR CUSTOM MANUFACTURE OF CLOTHING FEATURING EMBROIDERY, SPECIALTY STITCHING AND CUSTOM IMPRINTING OF CLOTHING WITH DECORATIVE DESIGN (U.S. CLS. 100, 103 AND 106).

FIRST USE 8-2-2010; IN COMMERCE 8-2-2010.

3,941,337. SPRINGFIELD SIGN AND GRAPHICS, INC., SPRINGFIELD, MO. SN 77-772,081. PUB. 6-15-2010, FILED 7-1-2009.

# Sign Hit

THE MARK CONSISTS OF STANDARD CHARACTERS WITHOUT CLAIM TO ANY PARTICULAR FONT, STYLE, SIZE, OR COLOR.

NO CLAIM IS MADE TO THE EXCLUSIVE RIGHT TO USE "SIGN", APART FROM THE MARK AS SHOWN.

**CLASS 6—METAL GOODS**

FOR NON-LUMINOUS AND NON-MECHANICAL METAL SIGNS (U.S. CLS. 2, 12, 13, 14, 23, 25 AND 50).

FIRST USE 8-1-2008; IN COMMERCE 8-1-2008.

**CLASS 9—ELECTRICAL AND SCIENTIFIC APPARATUS**

FOR BACKLIT SIGNS; ELECTRIC SIGNS; ELECTRONIC LED SIGNS; LUMINOUS SIGNS; MECHANICAL SIGNS; NEON SIGNS (U.S. CLS. 21, 23, 26, 36 AND 38).

FIRST USE 8-1-2008; IN COMMERCE 8-1-2008.

**CLASS 19—NON-METALLIC BUILDING MATERIALS**

FOR NON-LUMINOUS, NON-MECHANICAL SIGNS NOT OF METAL (U.S. CLS. 1, 12, 33 AND 50).

FIRST USE 8-1-2008; IN COMMERCE 8-1-2008.

3,941,336. SPRINGFIELD SIGN AND GRAPHICS, INC., SPRINGFIELD, MO. SN 77-772,078. PUB. 6-15-2010, FILED 7-1-2009.



NO CLAIM IS MADE TO THE EXCLUSIVE RIGHT TO USE "SIGN", APART FROM THE MARK AS SHOWN.

THE MARK CONSISTS OF THE WORDS "SIGN HIT" IN STYLIZED TEXT SEPARATED BY A STYLIZED ELEMENT AND UNDERLINED WITH THE WORD ".COM" IN THE UNDERLINE ELEMENT.

**CLASS 6—METAL GOODS**

FOR NON-LUMINOUS AND NON-MECHANICAL METAL SIGNS (U.S. CLS. 2, 12, 13, 14, 23, 25 AND 50).

FIRST USE 7-30-2009; IN COMMERCE 7-30-2009.

**CLASS 9—ELECTRICAL AND SCIENTIFIC APPARATUS**

FOR BACKLIT SIGNS; ELECTRIC SIGNS; ELECTRONIC LED SIGNS; LUMINOUS SIGNS; MECHANICAL SIGNS; NEON SIGNS (U.S. CLS. 21, 23, 26, 36 AND 38).

FIRST USE 7-30-2009; IN COMMERCE 7-30-2009.

**CLASS 19—NON-METALLIC BUILDING MATERIALS**

FOR NON-LUMINOUS, NON-MECHANICAL SIGNS NOT OF METAL (U.S. CLS. 1, 12, 33 AND 50).

FIRST USE 7-30-2009; IN COMMERCE 7-30-2009.

3,941,338. CONNECTIVA SYSTEMS, INC., NEW YORK, NY. SN 77-772,401. PUB. 5-18-2010, FILED 7-1-2009.

# CONNECTIVA

THE MARK CONSISTS OF STANDARD CHARACTERS WITHOUT CLAIM TO ANY PARTICULAR FONT, STYLE, SIZE, OR COLOR.

**CLASS 9—ELECTRICAL AND SCIENTIFIC APPARATUS**

FOR COMPUTER SOFTWARE FOR COLLECTING CUSTOMER DATA AND CONDUCTING ANALYTICS ON THE DATA, NAMELY, REVENUE ASSURANCE SOLUTIONS FOR ASSURING THAT REVENUE IS BEING RECEIVED AND FOR FRAUD AND RISK MANAGEMENT, SYSTEMS INTEGRATION SOLUTIONS, ANALYTICS FOR MARKETING AND CUSTOMER MANAGEMENT AND FOR ASSURING THAT SERVICES WERE DELIVERED, COMPUTER SOFTWARE AND HARDWARE AND COMPUTER PERIPHERAL EQUIPMENT FOR BILLING VERIFICATION, FRAUD DETECTION, MONITORING, MEASURING, ANALYZING, SECURITY MANAGING, NETWORK SURVEILLANCE, SIGNAL CLASSIFICATION, TRAFFIC MANAGING, CREATING AND MONITORING CALL DETAILED RECORDS, FRAUD DETECTION AND REPORTING INFORMATION EXTRACTED FROM NETWORKS, SWITCHES, OPERATING SYSTEMS, BASE STATIONS, BASE STATIONS' CONTROLLERS, PROBE MEDIATION PLATFORMS AND/OR BUSINESS SUPPORT SYSTEMS (U.S. CLS. 21, 23, 26, 36 AND 38).

FIRST USE 1-17-2006; IN COMMERCE 1-17-2006.

**CLASS 35—ADVERTISING AND BUSINESS**

FOR BUSINESS MANAGEMENT CONSULTING SERVICES, NAMELY, PROVIDING REVENUE ASSURANCE, BUSINESS FRAUD MANAGEMENT, RISK MANAGEMENT AND ANALYTICS OF CUSTOMER DATA; OUTSOURCING IN THE FIELD OF NETWORK MANAGEMENT (U.S. CLS. 100, 101 AND 102).

FIRST USE 1-17-2006; IN COMMERCE 1-17-2006.

**CLASS 42—SCIENTIFIC AND COMPUTER SERVICES**

FOR DESIGN AND IMPLEMENTATION OF SOFTWARE SOLUTIONS FOR THE PURPOSE OF PROVIDING REVENUE ASSURANCE, FRAUD MANAGEMENT, RISK MANAGEMENT AND ANALYTICS OF CUSTOMER DATA (U.S. CLS. 100 AND 101).

FIRST USE 1-17-2006; IN COMMERCE 1-17-2006.

3,941,339. SONY COMPUTER ENTERTAINMENT AMERICA LLC, FOSTER CITY, CA. SN 77-772,759. PUB. 10-13-2009, FILED 7-1-2009.

# ECHOSHIFT

THE MARK CONSISTS OF STANDARD CHARACTERS WITHOUT CLAIM TO ANY PARTICULAR FONT, STYLE, SIZE, OR COLOR.

**CLASS 9—ELECTRICAL AND SCIENTIFIC APPARATUS**

FOR DOWNLOADABLE COMPUTER GAME SOFTWARE AND VIDEO GAME SOFTWARE (U.S. CLS. 21, 23, 26, 36 AND 38).

FIRST USE 6-3-2009; IN COMMERCE 2-25-2010.

**CLASS 41—EDUCATION AND ENTERTAINMENT**

FOR OPERATING A REAL-TIME GAME FOR OTHERS OVER GLOBAL AND LOCAL AREA COMPUTER NETWORKS (U.S. CLS. 100, 101 AND 107).

FIRST USE 6-3-2009; IN COMMERCE 2-25-2010.

3,941,349. LYRASIS, ATLANTA, GA. SN 77-775,913. PUB. 7-6-2010, FILED 7-7-2009.

## ADVANCING LIBRARIES TOGETHER

THE MARK CONSISTS OF STANDARD CHARACTERS WITHOUT CLAIM TO ANY PARTICULAR FONT, STYLE, SIZE, OR COLOR.

**CLASS 35—ADVERTISING AND BUSINESS**

FOR DISASTER RECOVERY ASSISTANCE SERVICES FOR LIBRARIES AND MUSEUMS, NAMELY, BUSINESS PLANNING AND BUSINESS CONTINUITY CONSULTING; ADMINISTRATION AND MANAGEMENT OF RESEARCH GRANTS; LIBRARY NON-PROFIT MEMBERSHIP ASSOCIATION SERVICES, NAMELY, ADMINISTRATION ON BEHALF OF MEMBER LIBRARIES OF LICENSE AGREEMENTS WITH PUBLISHERS FOR USE OF REFERENCE MATERIALS AND LICENSE AGREEMENTS FOR SOFTWARE AND HARDWARE, PROVIDING LIBRARY PRODUCT DISCOUNTS TO ASSOCIATION MEMBERS, AND PROVIDING BUSINESS CONSULTATION TO MEMBER LIBRARIES IN THE FIELD OF LIBRARY SERVICES AND IN THE FIELD OF BROKERAGE OF INFORMATION (U.S. CLS. 100, 101 AND 102).

FIRST USE 4-1-2009; IN COMMERCE 4-1-2009.

**CLASS 39—TRANSPORTATION AND STORAGE**

FOR STORAGE OF ELECTRONIC MEDIA, NAMELY, IMAGES, TEXT AND AUDIO DATA FOR LIBRARIES, MUSEUMS AND HISTORICAL SOCIETIES (U.S. CLS. 100 AND 105).

FIRST USE 4-1-2009; IN COMMERCE 4-1-2009.

**CLASS 40—MATERIAL TREATMENT**

FOR DIGITAL ALTERATION AND RETOUCHING OF HISTORICAL DOCUMENTS (U.S. CLS. 100, 103 AND 106).

FIRST USE 4-1-2009; IN COMMERCE 4-1-2009.

**CLASS 41—EDUCATION AND ENTERTAINMENT**

FOR LIBRARIES; LIBRARY INFORMATION SERVICES; ON-LINE ACADEMIC LIBRARY SERVICES; EDUCATIONAL SERVICES, NAMELY, PROVIDING COURSES, SEMINARS, WORKSHOPS AND ONE-ON-ONE INSTRUCTION IN THE FIELD OF LIBRARY DISASTER RECOVERY, PRESERVATION OF LIBRARIES, INFORMATION RETRIEVAL, PRESERVING DOCUMENTS, DIGITIZATION OF DOCUMENTS, LIBRARY TECHNOLOGY, AND REMOTE STORAGE SOLUTIONS FOR LIBRARIES, MUSEUMS, AND HISTORICAL SOCIETIES; LIBRARY STAFF TRAINING; COMPUTER EDUCATION TRAINING; REFERENCE AND SCHOLARLY PUBLISHING FOR OTHERS, NAMELY, BOOK PUBLISHING AND MAGAZINE PUBLISHING; AND ACADEMIC AND UNIVERSITY PUBLISHING FOR OTHERS, NAMELY, BOOK PUBLISHING AND MAGAZINE PUBLISHING; DIGITAL IMAGING OF HISTORICAL DOCUMENTS; LIBRARY CONSULTATION SERVICES, NAMELY, PROVIDING INFORMATION AND ADVICE TO ACADEMIC, RESEARCH AND UNIVERSITY LIBRARIES IN ALL AREAS OF LIBRARIANSHIP (U.S. CLS. 100, 101 AND 107).

FIRST USE 4-1-2009; IN COMMERCE 4-1-2009.



**CLASS 42—SCIENTIFIC AND COMPUTER SERVICES**

FOR RESEARCH AND DEVELOPMENT OF TECHNOLOGY FOR USE BY LIBRARIES; LIBRARY TECHNOLOGY CONSULTING SERVICES; PROVIDING INFORMATION IN THE FIELD OF AVAILABLE COMPUTER TECHNOLOGIES FOR USE BY LIBRARIES; COMPUTER SERVICES, NAMELY, ELECTRONIC SCANNING, IMAGING AND DIGITIZING OF HISTORICAL DOCUMENTS; LIBRARY RESEARCH SERVICES, NAMELY, CONDUCTING RESEARCH OF LIBRARY MATERIALS FOR OTHERS ON A WIDE VARIETY OF SUBJECTS IN RESPONSE TO TELEPHONE, WRITTEN, ELECTRONIC MAIL, AND IN-PERSON REQUESTS (U.S. CLS. 100 AND 101).

FIRST USE 4-1-2009; IN COMMERCE 4-1-2009.

3,941,350. C-MEDIA ELECTRONICS INC., TAIPEI, TAIWAN.  
SN 77-776,090. PUB. 10-19-2010, FILED 7-7-2009.



THE MARK CONSISTS OF HALF CIRCLE TAPERED ARCH OVER A TAPERED SWIRL SHAPE.

**CLASS 9—ELECTRICAL AND SCIENTIFIC APPARATUS**

FOR COMPUTER HARDWARE; NOTEBOOK COMPUTERS; COMPUTER MOUSE; COMPUTER KEYBOARDS; MICROPHONES; SPEAKER; LOUDSPEAKERS; SOUND RECORDING AND SOUND REPRODUCING APPARATUS AND INSTRUMENTS; SOUND REPRODUCING APPARATUS; COMPUTER CHIPS; INTEGRATED CIRCUITS; SOUND CARDS; INTERFACE CARDS FOR COMPUTER; INTERNET PHONES; EARPHONES AND HEADPHONES; WIRELESS PORTABLE HEADPHONE SET; HANDS-FREE HEADPHONE SET; COMPUTER SOFTWARE FOR PLAYING AUDIO AND/OR VIDEO FILES FOR USE IN CONNECTION WITH HAND-HELD COMPUTERS; COMPUTER SOFTWARE FOR PLAYING AUDIO AND/OR VIDEO, NAMELY, COMPUTER SCREEN SAVER SOFTWARE; DOWNLOADABLE COMPUTER SOFTWARE FOR AUTOMATICALLY INSPECTING DIGITAL CONTENTS, INCLUDING VIDEO, SOUND, MUSIC, AND OTHER DIGITAL IMAGE AND CHARACTER FILES, FOR COMPUTER VIRUSES; COMPUTER SOFTWARE FOR PERFORMING VOICE MESSAGING FUNCTIONS; COMPUTER HARDWARE AND COMPUTER SOFTWARE PROGRAMS FOR THE INTEGRATION OF TEXTS, SOUND, GRAPHICS, STILL IMAGE AND MOVING PICTURES INTO AN INTERACTIVE DELIVERY FOR MULTIMEDIA APPLICATIONS; COMPUTER SOFTWARE FOR PROCESSING DIGITAL MUSICAL FILES; COMPUTER SOFTWARE FOR USE IN THE SAFEGUARDING OF DIGITAL FILES, INCLUDING AUDIO, VIDEO, TEXT, BINARY, STILL IMAGES, GRAPHICS AND MULTIMEDIA FILES; COMPUTER SOFTWARE FOR USE IN THE ENCRYPTION AND DECRYPTION OF DIGITAL FILES, INCLUDING AUDIO, VIDEO, TEXT, BINARY, STILL IMAGES, GRAPHIC AND MULTIMEDIA FILES; COMPUTER SOFTWARE TO CONTROL AND IMPROVE COMPUTER AND AUDIO EQUIPMENT SOUND QUALITY; COMPUTER SOFTWARE TO ENHANCE THE AUDIO-VISUAL CAPABILITIES OF MULTIMEDIA APPLICATIONS, NAMELY, FOR THE INTEGRATION OF TEXT, SOUND, GRAPHICS, STILL IMAGES AND MOVING PICTURES; COMPUTER SOFTWARE FOR USE IN RELATION TO DIGITAL ANIMATION AND SPECIAL EFFECTS IMAGES (U.S. CLS. 21, 23, 26, 36 AND 38).

FIRST USE 6-2-2009; IN COMMERCE 6-2-2009.

**CLASS 42—SCIENTIFIC AND COMPUTER SERVICES**

FOR DESIGN FOR OTHERS OF INTEGRATED CIRCUITS AND INTEGRATED CIRCUIT CORES FOR USE IN WIRELESS COMMUNICATIONS AND WIRELESS COMMUNICATION EQUIPMENT AND APPARATUS AND DIGITAL SIGNAL PROCESSORS (DSP); DESIGN, DEVELOPMENT, AND TESTING SERVICES FOR OTHERS IN THE FIELDS OF WAFERS, CHIPS, SEMICONDUCTOR AND INTEGRATED CIRCUIT FOR OTHERS; PROVIDING SPECIFIC INFORMATION AS REQUESTED BY CUSTOMERS VIA THE INTERNET; COMPUTER SERVICE, NAMELY, ACTING AS AN APPLICATION SERVICE PROVIDER IN THE FIELD OF KNOWLEDGE MANAGEMENT TO HOST COMPUTER APPLICATION SOFTWARE FOR SEARCHING AND RETRIEVING INFORMATION FROM DATABASES AND COMPUTER NETWORKS; PROVIDING INFORMATION AT THE SPECIFIC REQUEST OF END-USERS BY MEANS OF TELEPHONE OR GLOBAL COMPUTER NETWORKS; APPLICATION SERVICE PROVIDER, NAMELY, PROVIDING, HOSTING, MANAGING, DEVELOPING, AND MAINTAINING APPLICATIONS, SOFTWARE, WEB SITES, AND DATABASES IN THE FIELDS OF PERSONAL PRODUCTIVITY, WIRELESS COMMUNICATION, MOBILE INFORMATION ACCESS, AND REMOTE DATA MANAGEMENT FOR WIRELESS DELIVERY OF CONTENT TO HANDHELD COMPUTERS, LAPTOPS AND MOBILE ELECTRONIC DEVICES; CONSULTING SERVICES IN THE FIELD OF INTEGRATED CIRCUIT DESIGN AND DEVELOPMENT TECHNIQUES; RESEARCH AND DEVELOPMENT OF ADVANCED LEARNING TECHNOLOGIES AND TEACHING METHODS (U.S. CLS. 100 AND 101).

FIRST USE 6-2-2009; IN COMMERCE 1-7-2010.

3,941,351. SCHOOL APPAREL, INC., BURLINGAME, CA. SN 77-776,421. PUB. 5-11-2010, FILED 7-8-2009.

web+

THE MARK CONSISTS OF STANDARD CHARACTERS WITHOUT CLAIM TO ANY PARTICULAR FONT, STYLE, SIZE, OR COLOR.

#### CLASS 35—ADVERTISING AND BUSINESS

FOR ON-LINE SERVICES, NAMELY, ORDERING AND INVENTORY MONITORING AND CONTROLLING IN THE FIELD OF APPAREL AND SCHOOL AND CAREER UNIFORMS; INFORMATION MANAGEMENT SERVICES, NAMELY, SHIPMENT PROCESSING, PREPARING SHIPPING DOCUMENTS AND INVOICES, TRACKING DOCUMENTS, PACKAGES AND FREIGHT OVER COMPUTER NETWORKS, INTRANETS AND INTERNET; DATA PROCESSING SERVICES; COMPUTER SERVICES, NAMELY, PROVIDING A WEB-BASED SYSTEM AND ONLINE PORTAL FOR CUSTOMERS TO REMOTELY VIEW AVAILABLE PRODUCT AND INVENTORY, DOWNLOAD PRODUCT INFORMATION, AND MANAGE, MODIFY AND CONTROL THEIR ORDERS AND INVOICES (U.S. CLS. 100, 101 AND 102).  
FIRST USE 10-1-2005; IN COMMERCE 10-1-2005.

#### CLASS 36—INSURANCE AND FINANCIAL

FOR ELECTRONIC PAYMENT, NAMELY, ELECTRONIC PROCESSING AND TRANSMISSION OF BILL PAYMENT DATA (U.S. CLS. 100, 101 AND 102).  
FIRST USE 6-30-2009; IN COMMERCE 6-30-2009.

3,941,352. SCHOOL APPAREL, INC., BURLINGAME, CA. SN 77-776,429. PUB. 5-11-2010, FILED 7-8-2009.

web+

THE COLOR(S) BLACK, RED AND YELLOW IS/ARE CLAIMED AS A FEATURE OF THE MARK.

THE MARK CONSISTS OF THE WORD "WEB" IN LOWER CASE, WITH THE LETTERS "W" AND "B" SHOWN IN BLACK AND THE LETTER "E" SHOWN IN RED AND YELLOW IN THE DESIGN OF A WORLD MAP, FOLLOWED BY A PLUS SIGN SHOWN IN RED.

#### CLASS 35—ADVERTISING AND BUSINESS

FOR ON-LINE SERVICES, NAMELY, ORDERING AND INVENTORY MONITORING AND CONTROLLING IN THE FIELD OF APPAREL AND SCHOOL AND CAREER UNIFORMS; INFORMATION MANAGEMENT SERVICES, NAMELY, SHIPMENT PROCESSING, PREPARING SHIPPING DOCUMENTS AND INVOICES, TRACKING DOCUMENTS, PACKAGES AND FREIGHT OVER COMPUTER NETWORKS, INTRANET AND INTER NETS; DATA PROCESSING SERVICES; COMPUTER SERVICES, NAMELY, PROVIDING A WEB-BASED SYSTEM AND ONLINE PORTAL FOR CUSTOMERS TO REMOTELY VIEW AVAILABLE PRODUCT AND INVENTORY, DOWNLOAD PRODUCT INFORMATION, AND MANAGE, MODIFY AND CONTROL THEIR ORDERS AND INVOICES (U.S. CLS. 100, 101 AND 102).  
FIRST USE 10-1-2005; IN COMMERCE 6-30-2009.

#### CLASS 36—INSURANCE AND FINANCIAL

FOR ELECTRONIC PAYMENT, NAMELY, ELECTRONIC PROCESSING AND TRANSMISSION OF BILL PAYMENT DATA (U.S. CLS. 100, 101 AND 102).  
FIRST USE 10-1-2005; IN COMMERCE 6-30-2009.

3,941,354. BTG INTERNATIONAL LIMITED, LONDON, UNITED KINGDOM. SN 77-777,242. PUB. 5-25-2010, FILED 7-9-2009.

VARISOLVE

THE MARK CONSISTS OF STANDARD CHARACTERS WITHOUT CLAIM TO ANY PARTICULAR FONT, STYLE, SIZE, OR COLOR.

OWNER OF U.S. REG. NOS. 3,104,115 AND 3,756,169.

#### CLASS 1—CHEMICALS

FOR CHEMICALS FOR USE IN THE MANUFACTURE OF PHARMACEUTICALS IN THE NATURE OF THERAPEUTIC MICROFOAMS (U.S. CLS. 1, 5, 6, 10, 26 AND 46).  
FIRST USE 9-0-2010; IN COMMERCE 9-0-2010.

#### CLASS 5—PHARMACEUTICALS

FOR PHARMACEUTICAL PREPARATIONS, NAMELY, THERAPEUTIC MICROFOAMS FOR USE IN THE TREATMENT OF SCLEROTHERAPY OF VEINS WITH TREATMENT IN THE FIELDS OF PHLEBOLOGY, PROCTOLOGY AND ANGIOLOGY (U.S. CLS. 6, 18, 44, 46, 51 AND 52).  
FIRST USE 9-0-2010; IN COMMERCE 9-0-2010.

3,941,355. STORSIMPLE, INC., SANTA CLARA, CA. SN 77-777,934. PUB. 12-1-2009, FILED 7-9-2009.

STORSIMPLE

THE MARK CONSISTS OF STANDARD CHARACTERS WITHOUT CLAIM TO ANY PARTICULAR FONT, STYLE, SIZE, OR COLOR.

#### CLASS 9—ELECTRICAL AND SCIENTIFIC APPARATUS

FOR COMPUTER SOFTWARE FOR ACCESSING, MANAGING, COLLECTING, EDITING, SECURING, STORING, ORGANIZING, ARCHIVING, BACKING UP, RESTORING, REPLICATING AND TRANSMITTING DATA; COMPUTER HARDWARE (U.S. CLS. 21, 23, 26, 36 AND 38).  
FIRST USE 10-29-2010; IN COMMERCE 10-29-2010.

**CLASS 42—SCIENTIFIC AND COMPUTER SERVICES**

FOR COMPUTER CONSULTING SERVICES; PROVISION OF TECHNICAL ASSISTANCE AND TECHNICAL SUPPORT, NAMELY, TROUBLESHOOTING IN THE NATURE OF DIAGNOSING OF COMPUTER SOFTWARE AND HARDWARE PROBLEMS (U.S. CLS. 100 AND 101).

FIRST USE 1-28-2011; IN COMMERCE 1-28-2011.

3,941,362. HALE, NATHAN S., MT. PLEASANT, SC. SN 77-780,870. PUB. 6-8-2010, FILED 7-14-2009.

**WHISKEY CREEK RANCH**

THE MARK CONSISTS OF STANDARD CHARACTERS WITHOUT CLAIM TO ANY PARTICULAR FONT, STYLE, SIZE, OR COLOR.

NO CLAIM IS MADE TO THE EXCLUSIVE RIGHT TO USE "RANCH", APART FROM THE MARK AS SHOWN.

3,941,359. L.A. LOUVER GALLERY, INC., VENICE, CA. SN 77-780,039. PUB. 6-1-2010, FILED 7-13-2009.



THE MARK CONSISTS OF A FORWARD SLASH WITH THE WORDS "ROGUE WAVE".

**CLASS 35—ADVERTISING AND BUSINESS**

FOR ART GALLERIES (U.S. CLS. 100, 101 AND 102). FIRST USE 6-29-2001; IN COMMERCE 6-29-2001.

**CLASS 41—EDUCATION AND ENTERTAINMENT**

FOR EDUCATIONAL AND ENTERTAINMENT SERVICES, NAMELY, PRESENTING SEMINARS, LECTURES, SCREENINGS AND EXHIBITIONS IN THE FIELD OF ART AND ART APPRECIATION (U.S. CLS. 100, 101 AND 107).

FIRST USE 6-29-2001; IN COMMERCE 6-29-2001.

**CLASS 41—EDUCATION AND ENTERTAINMENT**

FOR RECREATIONAL SERVICES, NAMELY, PROVIDING HUNTING PRESERVES AND SUMMER CAMPS; ENVIRONMENTAL EDUCATION SERVICES, NAMELY, PROVIDING CLASSES ABOUT THE ENVIRONMENT; RECREATIONAL CAMP SERVICES THAT PROVIDE WILDLIFE AND NATURE STUDIES FOR OTHERS; ALL OF THE FOREGOING EXCLUDING GOLF TOURNAMENTS, GOLF INSTRUCTION, OR ANY ACTIVITIES OR SERVICES IN THE FIELD OF GOLF (U.S. CLS. 100, 101 AND 107).

FIRST USE 7-1-2010; IN COMMERCE 7-7-2010.

**CLASS 43—HOTEL AND RESTAURANT SERVICES**

FOR DUDE RANCHES; ALL OF THE FOREGOING EXCLUDING GOLF TOURNAMENTS, GOLF INSTRUCTION, OR ANY ACTIVITIES OR SERVICES IN THE FIELD OF GOLF (U.S. CLS. 100 AND 101).

FIRST USE 7-1-2010; IN COMMERCE 7-1-2010.

3,941,360. L.A. LOUVER GALLERY, INC., VENICE, CA. SN 77-780,045. PUB. 6-1-2010, FILED 7-13-2009.

**ROGUE WAVE**

THE MARK CONSISTS OF STANDARD CHARACTERS WITHOUT CLAIM TO ANY PARTICULAR FONT, STYLE, SIZE, OR COLOR.

**CLASS 35—ADVERTISING AND BUSINESS**

FOR ART GALLERIES (U.S. CLS. 100, 101 AND 102). FIRST USE 6-29-2001; IN COMMERCE 6-29-2001.

**CLASS 41—EDUCATION AND ENTERTAINMENT**

FOR EDUCATIONAL AND ENTERTAINMENT SERVICES, NAMELY, PRESENTING SEMINARS, LECTURES, SCREENINGS AND EXHIBITIONS IN THE FIELD OF ART AND ART APPRECIATION (U.S. CLS. 100, 101 AND 107).

FIRST USE 6-29-2001; IN COMMERCE 6-29-2001.

3,941,372. VENTI CORP., LAKELAND, TN. SN 77-784,792. PUB. 6-8-2010, FILED 7-20-2009.

**BOCCE BALLS**

THE MARK CONSISTS OF STANDARD CHARACTERS WITHOUT CLAIM TO ANY PARTICULAR FONT, STYLE, SIZE, OR COLOR.

**CLASS 30—STAPLE FOODS**

FOR MEATBALLS PREPARED INSIDE A DOUGH SOLD WITH AND WITHOUT SAUCE AND CHEESE (U.S. CL. 46).

FIRST USE 12-31-2003; IN COMMERCE 12-31-2003.

**CLASS 43—HOTEL AND RESTAURANT SERVICES**

FOR RESTAURANT, TAKE-OUT RESTAURANT, AND CATERING SERVICES (U.S. CLS. 100 AND 101).

FIRST USE 12-31-2003; IN COMMERCE 12-31-2003.

3,941,387. BDI PHARMA, INC., COLUMBIA, SC. SN 77-791,913. PUB. 6-15-2010, FILED 7-29-2009.

## BDI TRAILBLAZER

THE MARK CONSISTS OF STANDARD CHARACTERS WITHOUT CLAIM TO ANY PARTICULAR FONT, STYLE, SIZE, OR COLOR.

OWNER OF U.S. REG. NOS. 2,905,678, 3,564,356, AND 3,667,719.

### CLASS 35—ADVERTISING AND BUSINESS

FOR CONSULTING SERVICES IN THE FIELD OF MARKETING SPECIALTY PHARMACY AND HOME HEALTH PRODUCTS; ADVERTISING SERVICES, NAMELY, MARKETING AND PROMOTING THE GOODS OF OTHERS IN THE FIELD OF SPECIALTY PHARMACY AND HOME HEALTH PRODUCTS; BUSINESS CONSULTATION REGARDING MARKETING ACTIVITIES AND LAUNCHING OF NEW PRODUCTS; MARKETING SERVICES, NAMELY, DEVELOPING AND PROVIDING MARKETING PROGRAMS FOR OTHERS IN THE FIELD OF SPECIALTY PHARMACY AND HOME HEALTH CARE PRODUCTS (U.S. CLS. 100, 101 AND 102).

FIRST USE 3-1-2009; IN COMMERCE 3-1-2009.

### CLASS 41—EDUCATION AND ENTERTAINMENT

FOR EDUCATIONAL SERVICES, NAMELY, PROVIDING SEMINARS IN THE FIELD OF SPECIALTY PHARMACY AND HOME HEALTH PRODUCTS TO BE SOLD BY OTHERS AND DISTRIBUTING EDUCATIONAL MATERIALS IN CONNECTION THEREWITH (U.S. CLS. 100, 101 AND 107).

FIRST USE 3-1-2009; IN COMMERCE 3-1-2009.

3,941,388. BDI PHARMA, INC., COLUMBIA, SC. SN 77-791,941. PUB. 6-15-2010, FILED 7-29-2009.

## HEMOPHILIA TRAILBLAZER

THE MARK CONSISTS OF STANDARD CHARACTERS WITHOUT CLAIM TO ANY PARTICULAR FONT, STYLE, SIZE, OR COLOR.

NO CLAIM IS MADE TO THE EXCLUSIVE RIGHT TO USE "HEMOPHILIA", APART FROM THE MARK AS SHOWN.

### CLASS 35—ADVERTISING AND BUSINESS

FOR CONSULTING SERVICES IN THE FIELD OF MARKETING SPECIALTY PHARMACY AND HOME HEALTH PRODUCTS; ADVERTISING SERVICES, NAMELY, MARKETING AND PROMOTING THE GOODS OF OTHERS IN THE FIELD OF SPECIALTY PHARMACY AND HOME HEALTH PRODUCTS; BUSINESS CONSULTATION REGARDING MARKETING ACTIVITIES AND LAUNCHING OF NEW PRODUCTS; MARKETING SERVICES, NAMELY, DEVELOPING AND PROVIDING MARKETING PROGRAMS FOR OTHERS IN THE FIELD OF SPECIALTY PHARMACY AND HOME HEALTH CARE PRODUCTS (U.S. CLS. 100, 101 AND 102).

FIRST USE 2-9-2010; IN COMMERCE 2-9-2010.

### CLASS 41—EDUCATION AND ENTERTAINMENT

FOR EDUCATIONAL SERVICES, NAMELY, PROVIDING SEMINARS IN THE FIELD OF SPECIALTY PHARMACY AND HOME HEALTH PRODUCTS TO BE SOLD BY OTHERS AND DISTRIBUTING EDUCATIONAL MATERIALS IN CONNECTION THEREWITH (U.S. CLS. 100, 101 AND 107).

FIRST USE 2-9-2010; IN COMMERCE 2-9-2010.

3,941,389. BDI PHARMA, INC., COLUMBIA, SC. SN 77-791,958. PUB. 6-15-2010, FILED 7-29-2009.

## IVIG TRAILBLAZER

THE MARK CONSISTS OF STANDARD CHARACTERS WITHOUT CLAIM TO ANY PARTICULAR FONT, STYLE, SIZE, OR COLOR.

NO CLAIM IS MADE TO THE EXCLUSIVE RIGHT TO USE "IVIG", APART FROM THE MARK AS SHOWN.

### CLASS 35—ADVERTISING AND BUSINESS

FOR CONSULTING SERVICES IN THE FIELD OF MARKETING SPECIALTY PHARMACY AND HOME HEALTH PRODUCTS; ADVERTISING SERVICES, NAMELY, MARKETING AND PROMOTING THE GOODS OF OTHERS IN THE FIELD OF SPECIALTY PHARMACY AND HOME HEALTH PRODUCTS; BUSINESS CONSULTATION REGARDING MARKETING ACTIVITIES AND LAUNCHING OF NEW PRODUCTS; MARKETING SERVICES, NAMELY, DEVELOPING AND PROVIDING MARKETING PROGRAMS FOR OTHERS IN THE FIELD OF SPECIALTY PHARMACY AND HOME HEALTH PRODUCTS (U.S. CLS. 100, 101 AND 102).

FIRST USE 2-9-2010; IN COMMERCE 2-9-2010.

### CLASS 41—EDUCATION AND ENTERTAINMENT

FOR EDUCATIONAL SERVICES, NAMELY, PROVIDING SEMINARS IN THE FIELD OF SPECIALTY PHARMACY AND HOME HEALTH PRODUCTS TO BE SOLD BY OTHERS AND DISTRIBUTING EDUCATIONAL MATERIALS IN CONNECTION THEREWITH (U.S. CLS. 100, 101 AND 107).

FIRST USE 2-9-2010; IN COMMERCE 2-9-2010.

3,941,390. INSIGHT LIGHTING, INC., RIO RANCHO, NM.  
SN 77-793,347. PUB. 12-1-2009, FILED 7-30-2009.



OWNER OF U.S. REG. NOS. 2,636,424, 3,375,387, AND 3,384,431.

THE MARK CONSISTS OF A DEPICTION OF A TRIANGLE WITH AN ENTWINGING STYLIZED LEAF.

**CLASS 9—ELECTRICAL AND SCIENTIFIC APPARATUS**

FOR APPARATUS, NAMELY, LIGHT EMITTING DIODE (LED) DISPLAYS THAT ARE COMPATIBLE WITH SUSTAINABLE, ECOLOGICALLY FRIENDLY, AND ENERGY EFFICIENT LIGHT EMITTING DIODES (LEDS) (U.S. CLS. 21, 23, 26, 36 AND 38).

FIRST USE 12-31-2009; IN COMMERCE 12-31-2009.

**CLASS 11—ENVIRONMENTAL CONTROL APPARATUS**

FOR APPARATUS, NAMELY, LIGHTING ASSEMBLIES THAT ARE SUSTAINABLE, ECOLOGICALLY FRIENDLY, AND ENERGY EFFICIENT (U.S. CLS. 13, 21, 23, 31 AND 34).

FIRST USE 12-31-2009; IN COMMERCE 12-31-2009.

3,941,412. THE MULTIPLE MYELOMA RESEARCH FOUNDATION, INC., NORWALK, CT. SN 77-800,808. PUB. 6-22-2010, FILED 8-10-2009.



OWNER OF U.S. REG. NOS. 2,702,004 AND 2,925,067.  
NO CLAIM IS MADE TO THE EXCLUSIVE RIGHT TO USE "RESEARCH CONSORTIUM", APART FROM THE MARK AS SHOWN.

THE MARK CONSISTS OF THE LETTERS "MMRC" ABOVE THE WORDS "MULTIPLE MYELOMA RESEARCH CONSORTIUM", BOTH APPEARING TO THE RIGHT OF A TREE AND LEAF DESIGN.

SEC. 2(F) AS TO "MULTIPLE MYELOMA RESEARCH CONSORTIUM".

**CLASS 16—PAPER GOODS AND PRINTED MATTER**

FOR PRINTED PUBLICATIONS, NAMELY, NEWSLETTERS, PATIENT BROCHURES, AND PATIENT INFORMATION PACKETS COMPOSED OF PRINTED DOCUMENTS FEATURING INFORMATION ABOUT CHARITABLE FUNDRAISING ACTIVITIES FOR THE RESEARCH, TREATMENT AND CURE OF MULTIPLE MYELOMA (U.S. CLS. 2, 5, 22, 23, 29, 37, 38 AND 50).

FIRST USE 7-27-2009; IN COMMERCE 7-27-2009.

**CLASS 36—INSURANCE AND FINANCIAL**

FOR CHARITABLE FUNDRAISING; CHARITABLE FUNDRAISING SERVICES FEATURING THE PROVISION OF INFORMATION ABOUT TREATMENT AND CURE OF MULTIPLE MYELOMA, WHICH EDUCATES THE INDIVIDUAL, AND GIVES THEM THE OPPORTUNITY TO MAKE MONETARY DONATIONS; AND PROVIDING MEDICAL GRANTS TO THOSE RESEARCHING THE TREATMENT AND CURE OF MULTIPLE MYELOMA (U.S. CLS. 100, 101 AND 102).

FIRST USE 4-0-2007; IN COMMERCE 4-0-2007.

**CLASS 42—SCIENTIFIC AND COMPUTER SERVICES**

FOR MEDICAL AND SCIENTIFIC RESEARCH FEATURING THE DEVELOPMENT OF THERAPIES AND CURES FOR MULTIPLE MYELOMA THROUGH SCIENTIFIC COLLABORATION, ACCELERATED RESEARCH EFFORTS, AND THE ADVANCEMENT OF TECHNOLOGIES; AND PROVIDING ON-LINE INFORMATION ABOUT MEDICAL RESEARCH RELATING TO MYELOMA VIA A GLOBAL COMPUTER NETWORK (U.S. CLS. 100 AND 101).

FIRST USE 4-0-2007; IN COMMERCE 4-0-2007.

**CLASS 44—MEDICAL, BEAUTY AND AGRICULTURAL SERVICES**

FOR PROVIDING MEDICAL INFORMATION ABOUT THE TREATMENT OF MULTIPLE MYELOMA VIA A GLOBAL COMPUTER NETWORK (U.S. CLS. 100 AND 101).

FIRST USE 4-0-2007; IN COMMERCE 4-0-2007.

3,941,418. JAFFA, DAVID, LONDON WC2B 5HA, UNITED KINGDOM. SN 77-802,276. PUB. 6-29-2010, FILED 8-11-2009.

**PENDA**

THE MARK CONSISTS OF STANDARD CHARACTERS WITHOUT CLAIM TO ANY PARTICULAR FONT, STYLE, SIZE, OR COLOR.

THE ENGLISH TRANSLATION OF "PENDA" IS "CHOICE".

**CLASS 41—EDUCATION AND ENTERTAINMENT**

FOR EDUCATIONAL SERVICES, NAMELY, CONDUCTING DISTANCE LEARNING INSTRUCTION AT THE ELEMENTARY, MIDDLE AND HIGH SCHOOL LEVELS; EDUCATIONAL SERVICES, NAMELY, CONDUCTING PROGRAMS IN THE FIELDS OF SCIENCE AND MATHEMATICS, DELIVERED BY ELECTRONIC MEANS; EDUCATIONAL SERVICES, NAMELY, CONDUCTING PROGRAMS IN THE FIELD OF EXAMINATION AND TEST PREPARATION, DELIVERED BY ELECTRONIC MEANS; TRAINING SERVICES IN THE FIELDS OF SCIENCE AND MATHEMATICS AND EXAMINATION AND TEST PREPARATION; PROVIDING ONLINE CLASSES AND WORKSHOPS IN THE FIELDS OF SCIENCE AND MATHEMATICS AND EXAMINATION AND TEST PREPARATION (U.S. CLS. 100, 101 AND 107).

FIRST USE 9-11-2009; IN COMMERCE 9-11-2009.

**CLASS 42—SCIENTIFIC AND COMPUTER SERVICES**

FOR PROVIDING TEMPORARY USE OF NON-DOWNLOADABLE SOFTWARE FOR USE BY EDUCATIONAL INSTITUTIONS AND STUDENTS FOR TEST PREPARATION AND FOR TRANSMITTING AND RECEIVING REPORTS AND GRADES (U.S. CLS. 100 AND 101).

FIRST USE 9-11-2009; IN COMMERCE 9-11-2009.

3,941,425. BOARD OF REGENTS OF THE UNIVERSITY SYSTEM OF GEORGIA, ATLANTA, GA. SN 77-804,001. PUB. 1-5-2010, FILED 8-13-2009.



3,941,420. WASKI, JOHN L., DBA JOHN WASKI DESIGN LLC, WESTPORT, CT. SN 77-802,568. PUB. 1-26-2010, FILED 8-12-2009.

**IDENTITEA**

THE MARK CONSISTS OF STANDARD CHARACTERS WITHOUT CLAIM TO ANY PARTICULAR FONT, STYLE, SIZE, OR COLOR.

**CLASS 21—HOUSEWARES AND GLASS**

FOR COFFEE CUPS, TEA CUPS AND MUGS (U.S. CLS. 2, 13, 23, 29, 30, 33, 40 AND 50).

FIRST USE 7-22-2009; IN COMMERCE 7-22-2009.

**CLASS 30—STAPLE FOODS**

FOR COFFEE AND TEA; TEA (U.S. CL. 46).

FIRST USE 7-22-2009; IN COMMERCE 7-22-2009.

OWNER OF U.S. REG. NOS. 3,025,570, 3,380,967, AND OTHERS.

THE MARK CONSISTS OF A HALF CIRCLE OVER AN ARCH SUPPORTED BY THREE COLUMNS.

**CLASS 16—PAPER GOODS AND PRINTED MATTER**

FOR PRINTED REPORTS FEATURING CHARITABLE GIVING AND VOLUNTEER LEADERSHIP AND ASSISTANCE IN DEVELOPMENT AND FUNDRAISING ACTIVITIES; STATIONERY (U.S. CLS. 2, 5, 22, 23, 29, 37, 38 AND 50).

FIRST USE 8-0-2008; IN COMMERCE 8-0-2008.

**CLASS 36—INSURANCE AND FINANCIAL**

FOR ACCEPTING AND ADMINISTERING MONETARY CHARITABLE CONTRIBUTIONS; CHARITABLE FUND RAISING; PROVIDING ON-LINE INFORMATION IN THE FIELD OF CHARITABLE MONETARY GIVING THROUGH FINANCIAL AND ESTATE PLANNING (U.S. CLS. 100, 101 AND 102).

FIRST USE 8-0-2008; IN COMMERCE 8-0-2008.

**CLASS 41—EDUCATION AND ENTERTAINMENT**

FOR ARRANGING OF SEMINARS; SPECIAL EVENT PLANNING (U.S. CLS. 100, 101 AND 107).

FIRST USE 8-0-2008; IN COMMERCE 8-0-2008.

3,941,428. BROOKE KALANICK, NEW YORK, NY. SN 77-806,357. PUB. 6-1-2010, FILED 8-17-2009.



THE NAME(S), PORTRAIT(S), AND/OR SIGNATURE(S) SHOWN IN THE MARK IDENTIFIES "DR. BROOKE" KALANICK, WHOSE CONSENT(S) TO REGISTER IS MADE OF RECORD.

THE COLOR(S) BLUE, WHITE AND YELLOW IS/ARE CLAIMED AS A FEATURE OF THE MARK.

THE MARK CONSISTS OF THE TEXT "BETTER BY DR. BROOKE" IN WHITE LETTERS, WITH THE SECOND "T" IN "BETTER" IN YELLOW, INSIDE A LIGHT-BLUE CIRCLE. THE WHITE BORDER AROUND THE CIRCLE IS NOT AN ELEMENT OF THE MARK.

#### CLASS 41—EDUCATION AND ENTERTAINMENT

FOR EDUCATIONAL SERVICES, NAMELY, PROVIDING CLASSES, SEMINARS AND INDIVIDUAL TUTORIALS IN THE FIELDS OF NATUROPATHIC MEDICINE, NATURAL HEALTH, ACUPUNCTURE, WEIGHT LOSS AND NUTRITION (U.S. CLS. 100, 101 AND 107).

FIRST USE 1-1-2011; IN COMMERCE 1-1-2011.

#### CLASS 44—MEDICAL, BEAUTY AND AGRICULTURAL SERVICES

FOR MEDICAL AND BEAUTY SALON SERVICES IN THE FIELDS OF NATUROPATHIC MEDICINE, NATURAL HEALTH CARE, ACUPUNCTURE, WEIGHT LOSS AND NUTRITION (U.S. CLS. 100 AND 101).

FIRST USE 1-1-2011; IN COMMERCE 1-1-2011.

3,941,431. SATELLITE LOGISTICS GROUP, INC., HOUSTON, TX. SN 77-808,944. PUB. 6-8-2010, FILED 8-20-2009.

EcoBev

THE MARK CONSISTS OF STANDARD CHARACTERS WITHOUT CLAIM TO ANY PARTICULAR FONT, STYLE, SIZE, OR COLOR.

#### CLASS 35—ADVERTISING AND BUSINESS

FOR LOGISTICS SERVICES, NAMELY, ARRANGING THE TRANSPORTATION AND STORAGE OF BEVERAGE CONTAINERS FOR OTHERS IN COMPLIANCE WITH EPA REGULATIONS (U.S. CLS. 100, 101 AND 102).

FIRST USE 9-18-2009; IN COMMERCE 9-18-2009.

#### CLASS 39—TRANSPORTATION AND STORAGE

FOR TRANSPORTATION AND STORAGE OF BEVERAGE CONTAINERS IN COMPLIANCE WITH EPA REGULATIONS (U.S. CLS. 100 AND 105).

FIRST USE 9-18-2009; IN COMMERCE 9-18-2009.

#### CLASS 40—MATERIAL TREATMENT

FOR DESTRUCTION OF WASTE IN THE NATURE OF BEVERAGE CONTAINERS IN COMPLIANCE WITH EPA REGULATIONS (U.S. CLS. 100, 103 AND 106).

FIRST USE 9-18-2009; IN COMMERCE 9-18-2009.

3,941,437. AILERON, DAYTON, OH. SN 77-811,443. PUB. 6-8-2010, FILED 8-24-2009.

#### LEARNING, DOING, GIVING

THE MARK CONSISTS OF STANDARD CHARACTERS WITHOUT CLAIM TO ANY PARTICULAR FONT, STYLE, SIZE, OR COLOR.

NO CLAIM IS MADE TO THE EXCLUSIVE RIGHT TO USE "LEARNING", APART FROM THE MARK AS SHOWN.

#### CLASS 35—ADVERTISING AND BUSINESS

FOR CONSULTING AND ADVISORY SERVICES IN THE FIELDS OF BUSINESS ORGANIZATION, LEADERSHIP DEVELOPMENT, AND MANAGEMENT; BUSINESS ASSESSMENTS, NAMELY, ASSESSING BUSINESS MANAGEMENT STYLE AND EFFECTIVENESS FOR ENTREPRENEURS (U.S. CLS. 100, 101 AND 102).

FIRST USE 10-1-2008; IN COMMERCE 10-1-2008.

#### CLASS 41—EDUCATION AND ENTERTAINMENT

FOR EDUCATIONAL SERVICES, NAMELY, PROVIDING LIVE AND ON-LINE WORKSHOPS, SEMINARS, ROUNDTABLE PROGRAMS, CLASSES AND PEER LEARNING PROGRAMS IN THE FIELDS OF PROFESSIONAL MANAGEMENT FOR ENTREPRENEURS (U.S. CLS. 100, 101 AND 107).

FIRST USE 10-1-2008; IN COMMERCE 10-1-2008.

3,941,441. ILLINOIS AUTO ELECTRIC, AURORA, IL. SN 77-812,495. PUB. 7-13-2010, FILED 8-25-2009.

Orphan

THE MARK CONSISTS OF STANDARD CHARACTERS WITHOUT CLAIM TO ANY PARTICULAR FONT, STYLE, SIZE, OR COLOR.

**CLASS 12—VEHICLES**

FOR MOTORCYCLE PARTS, NAMELY, FRAMES, GAS TANKS, HANDLE BARS, WHEEL RIMS AND TIRES, SPROCKETS, BRAKE CALIPERS, BRAKE ROTORS, REAR SUSPENSION SYSTEMS, ENGINES, TRANSMISSIONS, FRONT FENDERS, REAR FENDERS; MOTORCYCLE REPLACEMENT PARTS, NAMELY, FRAMES, GAS TANKS, HANDLE BARS, WHEEL RIMS AND TIRES, SPROCKETS, BRAKE CALIPERS, BRAKE ROTORS, REAR SUSPENSION SYSTEMS, ENGINES, TRANSMISSIONS, FRONT FENDERS, REAR FENDERS (U.S. CLS. 19, 21, 23, 31, 35 AND 44).

FIRST USE 9-1-2009; IN COMMERCE 9-1-2009.

**CLASS 25—CLOTHING**

FOR APPAREL, NAMELY, T-SHIRTS, HATS, JACKETS, PANTS, SHOP SHIRTS, BUTTON-DOWN SHIRTS (U.S. CLS. 22 AND 39).

FIRST USE 9-1-2009; IN COMMERCE 9-1-2009.

**CLASS 37—CONSTRUCTION AND REPAIR**

FOR MOTORCYCLE CUSTOMIZATION SERVICES; MOTORCYCLE REPAIR AND MAINTENANCE SERVICES (U.S. CLS. 100, 103 AND 106).

FIRST USE 9-1-2009; IN COMMERCE 9-1-2009.

3,941,455. MEDIYAK, LLC, RIDGEWOOD, NJ. SN 77-822,852. PUB. 7-6-2010, FILED 9-9-2009.

# MEDIYAK

THE MARK CONSISTS OF STANDARD CHARACTERS WITHOUT CLAIM TO ANY PARTICULAR FONT, STYLE, SIZE, OR COLOR.

**CLASS 35—ADVERTISING AND BUSINESS**

FOR PROVIDING A WEBSITE FEATURING DIRECTORIES AND PROFILES OF PHYSICIANS AND OTHER HEALTH CARE PROVIDERS, PHYSICIAN REFERRALS, MEDICAL REFERRALS, AND APPOINTMENT SCHEDULING IN THE FIELDS OF HEALTH AND WELLNESS (U.S. CLS. 100, 101 AND 102).

FIRST USE 9-12-2009; IN COMMERCE 9-12-2009.

**CLASS 44—MEDICAL, BEAUTY AND AGRICULTURAL SERVICES**

FOR PROVIDING ONLINE INFORMATION IN THE FIELDS OF HEALTH AND WELLNESS; PROVIDING AN INTERACTIVE WEBSITE IN THE FIELDS OF HEALTH AND WELLNESS; PROVIDING A RESOURCE WEBSITE FEATURING INFORMATION IN THE FIELDS OF HEALTH AND WELLNESS (U.S. CLS. 100 AND 101).

FIRST USE 9-12-2009; IN COMMERCE 9-12-2009.

3,941,467. BLACKFIN FRANCHISING, LLC, LITTLETON, CO. SN 77-829,963. PUB. 6-8-2010, FILED 9-18-2009.

# Blackfin

THE MARK CONSISTS OF STANDARD CHARACTERS WITHOUT CLAIM TO ANY PARTICULAR FONT, STYLE, SIZE, OR COLOR.

**CLASS 35—ADVERTISING AND BUSINESS**

FOR FRANCHISING, NAMELY, OFFERING TECHNICAL ASSISTANCE IN THE ESTABLISHMENT AND/OR OPERATION OF LEGAL SERVICES, INCOME TAX CONSULTATION, INCOME TAX PREPARATION, TAX ADVISORY SERVICES, TAX AND TAXATION PLANNING, ADVICE, INFORMATION AND CONSULTANCY SERVICES, TAX ASSESSMENT, TAX CONSULTATION, TAX FILING SERVICES, TAX LIEN MANAGEMENT SERVICES, TAX PREPARATION; INCOME TAX CONSULTATION; INCOME TAX PREPARATION; TAX ADVISORY SERVICES; TAX AND TAXATION PLANNING, ADVICE, INFORMATION AND CONSULTANCY SERVICES; TAX ASSESSMENT; TAX CONSULTATION; TAX FILING SERVICES; TAX LIEN MANAGEMENT SERVICES; TAX PREPARATION (U.S. CLS. 100, 101 AND 102).

FIRST USE 7-15-2010; IN COMMERCE 7-15-2010.

**CLASS 45—PERSONAL AND LEGAL SERVICES**

FOR LEGAL SERVICES (U.S. CLS. 100 AND 101).

FIRST USE 7-15-2010; IN COMMERCE 7-15-2010.

3,941,470. BLACKFIN FRANCHISING, LLC, LITTLETON, CO. SN 77-830,093. PUB. 6-8-2010, FILED 9-18-2009.



THE MARK CONSISTS OF FOUR STRAIGHT VERTICAL LINES AND THREE HORIZONTAL LINES WITH THE APPEARANCE OF WRAPPING AROUND THE VERTICAL LINES, FOLLOWED BY THE WORD "BLACKFIN".

**CLASS 35—ADVERTISING AND BUSINESS**

FOR FRANCHISING, NAMELY, OFFERING TECHNICAL ASSISTANCE IN THE ESTABLISHMENT AND/OR OPERATION OF LEGAL SERVICES, INCOME TAX CONSULTATION, INCOME TAX PREPARATION, TAX ADVISORY SERVICES, TAX AND TAXATION PLANNING, ADVICE, INFORMATION AND CONSULTANCY SERVICES, TAX ASSESSMENT, TAX CONSULTATION, TAX FILING SERVICES, TAX LIEN MANAGEMENT SERVICES, TAX PREPARATION; INCOME TAX CONSULTATION; INCOME TAX PREPARATION; TAX ADVISORY SERVICES; TAX AND TAXATION PLANNING, ADVICE, INFORMATION AND CONSULTANCY SERVICES; TAX ASSESSMENT; TAX CONSULTATION; TAX FILING SERVICES; TAX LIEN MANAGEMENT SERVICES; TAX PREPARATION (U.S. CLS. 100, 101 AND 102).

FIRST USE 7-15-2010; IN COMMERCE 7-15-2010.



**CLASS 45—PERSONAL AND LEGAL SERVICES**

FOR LEGAL SERVICES (U.S. CLS. 100 AND 101).  
FIRST USE 7-15-2010; IN COMMERCE 7-15-2010.

---

3,941,474. WORLDWIDE INTERACTIVE NETWORK, INC.,  
KINGSTON, TN. SN 77-835,070. PUB. 5-11-2010, FILED 9-  
25-2009.



NO CLAIM IS MADE TO THE EXCLUSIVE RIGHT TO USE "STRATEGIC", APART FROM THE MARK AS SHOWN.

THE MARK CONSISTS OF A PLANETARY DESIGN HAVING TWO ORBITS WITH THE LETTERS "WIN" APPEARING TO THE RIGHT OF THE PLANETARY DESIGN AND THE WORDS "STRATEGIC COMPASS" BELOW THE LETTERS "WIN".

**CLASS 9—ELECTRICAL AND SCIENTIFIC APPARATUS**

FOR COMPUTER SOFTWARE FOR USE IN ANALYZING EDUCATIONAL AND WORKFORCE INDICATORS IN CONNECTION WITH LOCAL, REGIONAL, AND STATE ECONOMIC TRENDS (U.S. CLS. 21, 23, 26, 36 AND 38).

FIRST USE 1-14-2009; IN COMMERCE 1-14-2009.

**CLASS 42—SCIENTIFIC AND COMPUTER SERVICES**

FOR COMPUTER SERVICES IN THE NATURE OF CUSTOMIZED WEB PAGES FEATURING USER DEFINED INFORMATION, PERSONAL PROFILES AND INFORMATION; COMPUTER SERVICES, NAMELY, HOSTING AND MAINTAINING AN ON-LINE WEB SITE FOR OTHERS TO ANALYZE EDUCATION AND WORKFORCE INDICATORS IN CONNECTION WITH LOCAL, REGIONAL, AND STATE ECONOMIC TRENDS (U.S. CLS. 100 AND 101).

FIRST USE 1-14-2009; IN COMMERCE 1-14-2009.

---

3,941,475. MIZ LOLA'S SPIRITS & GAMING, LLC, HENDERSON, NV. SN 77-835,283. PUB. 2-16-2010, FILED 9-25-2009.

**MIZ LOLA'S**

THE MARK CONSISTS OF STANDARD CHARACTERS WITHOUT CLAIM TO ANY PARTICULAR FONT, STYLE, SIZE, OR COLOR.

**CLASS 41—EDUCATION AND ENTERTAINMENT**

FOR CASINO SERVICES (U.S. CLS. 100, 101 AND 107).  
FIRST USE 8-23-2010; IN COMMERCE 8-23-2010.

**CLASS 43—HOTEL AND RESTAURANT SERVICES**

FOR COCKTAIL LOUNGE SERVICES (U.S. CLS. 100 AND 101).  
FIRST USE 8-23-2010; IN COMMERCE 8-23-2010.

---

3,941,477. BIG BANG PRODUCTIONS LLC, BOULDER, CO.  
SN 77-835,746. PUB. 8-3-2010, FILED 9-26-2009.

**THE ADVENTURES OF MR.  
TOMPKINS**

THE MARK CONSISTS OF STANDARD CHARACTERS WITHOUT CLAIM TO ANY PARTICULAR FONT, STYLE, SIZE, OR COLOR.

THE NAME(S), PORTRAIT(S), AND/OR SIGNATURE(S) SHOWN IN THE MARK DOES NOT IDENTIFY A PARTICULAR LIVING INDIVIDUAL.

**CLASS 9—ELECTRICAL AND SCIENTIFIC APPARATUS**

FOR A SERIES OF MOTION PICTURE FILMS ABOUT HISTORY AND SCIENCE; PRE-RECORDED DVDS FEATURING FICTIONAL AND NON-FICTIONAL PROGRAMS, MOVIES AND VIDEOS IN THE FIELDS OF HISTORY AND SCIENCE (U.S. CLS. 21, 23, 26, 36 AND 38).

FIRST USE 4-2-2010; IN COMMERCE 4-2-2010.

**CLASS 16—PAPER GOODS AND PRINTED MATTER**

FOR A SERIES OF BOOKS, WORKBOOKS, EDUCATIONAL WORKBOOKS, COMIC BOOKS AND WRITTEN ARTICLES IN THE FIELDS OF HISTORY AND SCIENCE (U.S. CLS. 2, 5, 22, 23, 29, 37, 38 AND 50).

FIRST USE 4-2-2010; IN COMMERCE 4-2-2010.

**CLASS 41—EDUCATION AND ENTERTAINMENT**

FOR PROVIDING A WEB SITE FEATURING TEMPORARY USE OF NON-DOWNLOADABLE FICTIONAL AND NON-FICTIONAL ENTERTAINMENT PROGRAMS, MOVIES AND VIDEOS IN THE FIELDS OF HISTORY AND SCIENCE (U.S. CLS. 100, 101 AND 107).

FIRST USE 5-0-2009; IN COMMERCE 5-0-2009.

3,941,480. AISIN SEIKI KABUSHIKI KAISHA, DBA AISIN SEIKI CO., LTD., AICHI-KEN, JAPAN. SN 77-837,998. PUB. 6-15-2010, FILED 9-30-2009.

3,941,494. ITA PARTNERS, INC., PHILADELPHIA, PA. SN 77-847,233. PUB. 4-13-2010, FILED 10-13-2009.

## IMMUNOMEASURE

THE MARK CONSISTS OF THE STYLIZED LETTERS FOR THE WORD "IMMUNOMEASURE".

### CLASS 5—PHARMACEUTICALS

FOR DIAGNOSTIC KITS CONSISTING PRIMARILY OF MONOCLONAL ANTIBODIES, BUFFERS, AND REAGENTS FOR USE IN DISEASE TESTING (U.S. CLS. 6, 18, 44, 46, 51 AND 52).

FIRST USE 2-29-2008; IN COMMERCE 8-31-2010.

### CLASS 9—ELECTRICAL AND SCIENTIFIC APPARATUS

FOR CLINICAL LABORATORY ANALYZERS FOR MEASURING, TESTING AND ANALYZING BLOOD AND OTHER BODILY FLUIDS; LIQUID ANALYZERS; LABORATORY INSTRUMENTS, NAMELY, RADIATION DEVICES IN THE NATURE OF ULTRAVIOLET, VISIBLE, OR INFRA-RED LIGHT BOXES FOR THE ANALYSIS OF BODILY FLUIDS; SCIENTIFIC INSTRUMENTS, NAMELY, ELECTRONIC ANALYZERS FOR MEASURING, TESTING AND DETECTING CONTAMINANTS AND ENVIRONMENTAL POLLUTANTS; SCIENTIFIC INSTRUMENTS, NAMELY, ELECTRONIC ANALYZERS FOR TESTING CONSUMER PRODUCTS FOR THE PRESENCE OF CONTAMINANTS; COMPUTER SOFTWARE FOR OPERATING AND CONTROLLING ANTIBODY DETECTION SYSTEMS, QUANTITATIVE ANALYSIS SYSTEMS, DEVICES FOR DETECTING, TESTING AND ANALYZING HAZARDOUS CHEMICAL SUBSTANCES (U.S. CLS. 21, 23, 26, 36 AND 38).

FIRST USE 2-29-2008; IN COMMERCE 8-31-2010.

### CLASS 10—MEDICAL APPARATUS

FOR MEDICAL INSTRUMENTS, DEVICES AND PARTS THEREOF FOR USE IN ANTIBODY DETECTION, QUANTITATIVE ANALYSIS, MOLECULAR STRUCTURE ANALYSIS AND DETECTION OF TOXIC CHEMICAL SUBSTANCES, HAZARDOUS CHEMICAL SUBSTANCES AND CONTAMINANTS FOR MEDICAL DIAGNOSTICS (U.S. CLS. 26, 39 AND 44).

FIRST USE 2-29-2008; IN COMMERCE 8-31-2010.

### CLASS 11—ENVIRONMENTAL CONTROL APPARATUS

FOR APPARATUS AND INSTRUMENTS FOR USE IN THE PURIFICATION, SEPARATION AND STERILIZATION OF LIQUIDS AND GASES USED IN THE BIOTECHNOLOGY, PHARMACEUTICAL, MEDICAL, AND BIOPHARMACEUTICAL INDUSTRIES (U.S. CLS. 13, 21, 23, 31 AND 34).

FIRST USE 2-29-2008; IN COMMERCE 8-31-2010.

## EVIDENCE-BASED INTELLIGENCE FOR IMPROVED OUTCOMES

THE MARK CONSISTS OF STANDARD CHARACTERS WITHOUT CLAIM TO ANY PARTICULAR FONT, STYLE, SIZE, OR COLOR.

NO CLAIM IS MADE TO THE EXCLUSIVE RIGHT TO USE "EVIDENCE-BASED INTELLIGENCE", APART FROM THE MARK AS SHOWN.

### CLASS 35—ADVERTISING AND BUSINESS

FOR CONSULTING SERVICES TO REDUCE COSTS AND UNNECESSARY UTILIZATION IN THE TREATMENT OF CRITICAL ILLNESSES (U.S. CLS. 100, 101 AND 102).

FIRST USE 5-5-2010; IN COMMERCE 5-5-2010.

### CLASS 42—SCIENTIFIC AND COMPUTER SERVICES

FOR PROVIDING TEMPORARY USE OF A NON-DOWNLOADABLE WEB-BASED SOFTWARE APPLICATION FOR ENSURING THE SELECTION OF AND REIMBURSEMENT FOR APPROPRIATE TREATMENTS FOR CRITICAL ILLNESSES (U.S. CLS. 100 AND 101).

FIRST USE 5-5-2010; IN COMMERCE 5-5-2010.

### CLASS 44—MEDICAL, BEAUTY AND AGRICULTURAL SERVICES

FOR MANAGED HEALTH CARE SERVICES; CONSULTING SERVICES IN THE FIELD OF HEALTH, NAMELY, CONSULTING SERVICES AMONG MEDICAL PROVIDERS, INSURERS, AND PATIENTS WITH CRITICAL ILLNESSES; PROVIDING MEDICAL INFORMATION, CONSULTANCY, AND ADVISORY SERVICES; MEDICAL COUNSELING SERVICES FOR PATIENTS AND THEIR FAMILIES; CONSULTING SERVICES IN THE FIELD OF HEALTH, NAMELY, MEDICAL TREATMENT PLAN REVIEW AND VALIDATION; TRACKING PATIENT TREATMENT, PROGRESS, CONCERNS, AND COMPLIANCE ISSUES, NAMELY, MAINTAINING A DATABASE FOR OTHERS IN THE FIELD OF CRITICAL ILLNESS TREATMENT INFORMATION AND FEATURING INPUTTING AND COLLECTION OF DATA AND INFORMATION ALL FOR TREATMENT AND DIAGNOSTIC PURPOSES (U.S. CLS. 100 AND 101).

FIRST USE 5-5-2010; IN COMMERCE 5-5-2010.

### CLASS 45—PERSONAL AND LEGAL SERVICES

FOR CASE MANAGEMENT SERVICES, NAMELY, COORDINATION OF SERVICES AMONG MEDICAL PROVIDERS, INSURERS, AND PATIENTS WITH CRITICAL ILLNESSES (U.S. CLS. 100 AND 101).

FIRST USE 5-5-2010; IN COMMERCE 5-5-2010.

3,941,496. NARDINI, KRISTY, DBA EARTH FRIENDLY DESIGN GROUP, SOLANA BEACH, CA. SN 77-847,648. PUB. 3-16-2010, FILED 10-13-2009.

# Tazzini

THE MARK CONSISTS OF STANDARD CHARACTERS WITHOUT CLAIM TO ANY PARTICULAR FONT, STYLE, SIZE, OR COLOR.

## CLASS 20—FURNITURE AND ARTICLES NOT OTHERWISE CLASSIFIED

FOR NON-METAL BOTTLE CAPS; NON-METAL CAPS FOR BOTTLES; NON-METALLIC BOTTLE CAPS; NON-METALLIC BOTTLE STOPPERS (U.S. CLS. 2, 13, 22, 32 AND 50).

FIRST USE 1-1-2010; IN COMMERCE 1-1-2010.

## CLASS 21—HOUSEWARES AND GLASS

FOR BOTTLES, SOLD EMPTY; CONTAINERS FOR HOUSEHOLD OR KITCHEN USE; CONTAINERS FOR HOUSEHOLD OR KITCHEN USE NOT OF PRECIOUS METAL; CONTAINERS FOR HOUSEHOLD USE; DEWAR BOTTLES AND VESSELS; DRINKING FLASKS; DRINKING VESSELS; EMPTY WATER BOTTLES FOR BICYCLES; HOUSEHOLD CONTAINERS FOR FOODS; INSULATED CONTAINERS FOR FOOD OR BEVERAGE FOR DOMESTIC USE; NEOPRENE ZIPPERED BOTTLE HOLDERS; PLASTIC STORAGE CONTAINERS FOR HOUSEHOLD OR DOMESTIC USE; PLASTIC STORAGE CONTAINERS FOR HOUSEHOLD USE; PORTABLE PLASTIC CONTAINERS FOR STORING HOUSEHOLD AND KITCHEN GOODS; SPORTS BOTTLES SOLD EMPTY (U.S. CLS. 2, 13, 23, 29, 30, 33, 40 AND 50).

FIRST USE 1-1-2010; IN COMMERCE 1-1-2010.

3,941,524. OVER THE SUN, LLC, LOVELAND, CO. SN 77-858,794. PUB. 6-8-2010, FILED 10-27-2009.



THE MARK CONSISTS OF THE WORD "ICONJI" IN LOWER CASE, SANS SERIF TYPE WITH A ROUNDED CORNER BOX AROUND THE INITIAL "I".

## CLASS 9—ELECTRICAL AND SCIENTIFIC APPARATUS

FOR COMPUTER APPLICATION SOFTWARE FOR MOBILE PHONES AND OTHER MOBILE DEVICES; TYPEFACE RECORDED ON COMPUTER MEDIA MADE OF GRAPHIC SYMBOLS REPRESENTING ALPHANUMERIC CHARACTERS, WORDS OR IDEAS FOR USE IN THE CREATION AND TRANSMISSION OF ELECTRONIC MESSAGES (U.S. CLS. 21, 23, 26, 36 AND 38).

FIRST USE 5-20-2010; IN COMMERCE 5-20-2010.

## CLASS 42—SCIENTIFIC AND COMPUTER SERVICES

FOR PROVIDING A WEBSITE FOR USERS TO CREATE, UPLOAD AND SHARE GRAPHIC SYMBOLS REPRESENTING ALPHANUMERIC CHARACTERS, WORDS OR IDEAS FOR USE IN THE CREATION AND TRANSMISSION OF ELECTRONIC MESSAGES (U.S. CLS. 100 AND 101).

FIRST USE 10-20-2010; IN COMMERCE 10-20-2010.

3,941,525. NATIONAL STAFF DEVELOPMENT COUNCIL, OXFORD, OH. SN 77-859,027. PUB. 4-13-2010, FILED 10-28-2009.

# LEARNING FORWARD

THE MARK CONSISTS OF STANDARD CHARACTERS WITHOUT CLAIM TO ANY PARTICULAR FONT, STYLE, SIZE, OR COLOR.

NO CLAIM IS MADE TO THE EXCLUSIVE RIGHT TO USE "LEARNING", APART FROM THE MARK AS SHOWN.

## CLASS 9—ELECTRICAL AND SCIENTIFIC APPARATUS

FOR ELECTRONIC DOWNLOADABLE PUBLICATIONS, NAMELY, NEWSLETTERS, MONOGRAPHS, MAGAZINES, TRAINING AND RESOURCE MANUALS, AND BOOKS IN THE FIELD OF IMPROVING K-12 STUDENT LEARNING THROUGH PROFESSIONAL AND ORGANIZATIONAL DEVELOPMENT (U.S. CLS. 21, 23, 26, 36 AND 38).

FIRST USE 9-1-2010; IN COMMERCE 9-1-2010.

## CLASS 16—PAPER GOODS AND PRINTED MATTER

FOR PAMPHLETS, BROCHURES, NEWSLETTERS, JOURNALS, MAGAZINES, BOOKLETS, TRAINING MANUALS, AND BOOKS IN THE FIELD OF IMPROVING K-12 STUDENT LEARNING THROUGH PROFESSIONAL AND ORGANIZATIONAL DEVELOPMENT (U.S. CLS. 2, 5, 22, 23, 29, 37, 38 AND 50).

FIRST USE 9-1-2010; IN COMMERCE 9-1-2010.

## CLASS 41—EDUCATION AND ENTERTAINMENT

FOR EDUCATIONAL SERVICES, NAMELY, CONDUCTING CONFERENCES, WORKSHOPS, CLASSES, SEMINARS, ONLINE CLASSES, AND PROGRAMS IN THE FIELD OF K-12 EDUCATOR PROFESSIONAL LEARNING AND DEVELOPMENT AND DISTRIBUTING COURSE MATERIALS IN CONNECTION THEREWITH (U.S. CLS. 100, 101 AND 107).

FIRST USE 9-1-2010; IN COMMERCE 9-1-2010.

3,941,528. POSTELL PUBLISHING LLC, BOWIE, MD. SN 77-862,146. PUB. 4-20-2010, FILED 10-31-2009.



NO CLAIM IS MADE TO THE EXCLUSIVE RIGHT TO USE "PUBLISHING LLC", APART FROM THE MARK AS SHOWN.

THE COLOR(S) PURPLE, WHITE AND BLACK IS/ARE CLAIMED AS A FEATURE OF THE MARK.

THE MARK CONSISTS OF THE WORDING "POSTELL PUBLISHING LLC" AND DESIGN. THE DESIGN CONSISTS OF A PURPLE SQUARE GRAPHIC. WITHIN THE SQUARE ARE THE STYLIZED LETTERS "QBP" IN WHITE DESIGNED WITH CURVES AT THE LONGER END OF EACH VERTICAL LINE ASSOCIATED WITH EACH LETTER SO THAT THE CURVE OF THE BOTTOM OF THE "Q" AND THE BOTTOM OF THE "P" MEET TOGETHER AT THE BASE OF THE SQUARE, AND THE CURVE ASSOCIATED WITH THE VERTICAL LINE MAKING THE TOP OF THE "B" CURVES ABOVE AND OVER THE TOP OF THE CIRCLE MAKING THE "Q". BELOW THE DESIGN IS THE STYLIZED WORDING "POSTELL PUBLISHING LLC" IN BLACK. THE ACRONYM "LLC" APPEARS IN A VERY SMALL FONT. A BLACK STAR DOTS EACH LETTER "I" IN THE TERM "PUBLISHING".

#### CLASS 35—ADVERTISING AND BUSINESS

FOR ADVERTISEMENT AND PUBLICITY SERVICES BY TELEVISION, RADIO, MAIL; ADVERTISING AND ADVERTISEMENT SERVICES; ADVERTISING AND BUSINESS SERVICES, NAMELY, SECURING AIRTIME ON ALL FORMS OF MEDIA COMMUNICATIONS STATIONS, SYSTEMS, NETWORKS, AND SERVICES FOR THE PURPOSE OF PROMOTING THE GOODS AND SERVICES OF OTHERS; ADVERTISING AND MARKETING SERVICES, NAMELY, PROMOTING THE GOODS AND SERVICES OF OTHERS; ADVERTISING AND PROMOTION SERVICES AND RELATED CONSULTING; ADVERTISING CONSULTATION; ADVERTISING SERVICES, NAMELY, CREATING CORPORATE AND BRAND IDENTITY FOR OTHERS; ADVERTISING SERVICES, NAMELY, PROMOTING AND MARKETING THE GOODS AND SERVICES OF OTHERS THROUGH ALL PUBLIC COMMUNICATION MEANS; ADVERTISING TEXT PUBLICATION SERVICES; ADVERTISING THROUGH ALL PUBLIC COMMUNICATION MEANS; ADVERTISING VIA ELECTRONIC MEDIA AND SPECIFICALLY THE INTERNET; ADVERTISING, MARKETING AND PROMOTION SERVICES; ADVERTISING, MARKETING AND PROMOTIONAL SERVICES RELATED TO ALL INDUSTRIES FOR THE PURPOSE OF FACILITATING NETWORKING AND SOCIALIZING OPPORTUNITIES FOR BUSINESS PURPOSES; ARRANGING AND CONDUCTING BUSINESS CONFERENCES; ARRANGING AND CONDUCTING MARKETING PROMOTIONAL EVENTS FOR OTHERS; ARRANGING AND CONDUCTING OF FAIRS AND EXHIBITIONS FOR BUSINESS AND ADVERTISING PURPOSES; ARRANGING OF SUBSCRIPTIONS FOR THE PUBLICATIONS OF OTHERS; ARRANGING SUBSCRIPTIONS OF THE ONLINE PUBLICATIONS OF OTHERS; ART GALLERIES; BRAND CONCEPT AND BRAND DEVELOPMENT SERVICES FOR CORPORATE AND INDIVIDUAL CLIENTS; BRAND CONCEPT AND BRAND DEVELOPMENT SERVICES FOR CORPORATE CLIENTS; BRAND IMAGERY CONSULTING SERVICES; BRAND POSITIONING SERVICES; BRANDING SERVICES, NAMELY, CONSULTING, DEVELOPMENT, MANAGEMENT AND MARKETING OF BRANDS FOR BUSINESSES; BUSINESS MARKETING CONSULTING SERVICES; COMPILATION OF ADVERTISEMENTS FOR USE AS WEB PAGES ON THE INTERNET; COMPUTERIZED ON-LINE RETAIL STORE SERVICES IN THE FIELD OF FICTION,

NON-FICTION AND PICTURE BOOKS; CONCEPT AND BRAND DEVELOPMENT SERVICES FOR CORPORATE CLIENTS; CORPORATE IDENTITY SERVICES; CORPORATE IMAGE CONSULTING SERVICES; CREATING AND UPDATING ADVERTISING MATERIAL; CREATING TRADEMARKS FOR OTHERS; CREATIVE MARKETING DESIGN SERVICES; CUSTOM WRITING SERVICES COMPRISING PUBLIC RELATIONS AND MARKETING MATERIALS FOR THE AUDIO, VIDEO AND TECHNOLOGY INDUSTRIES; DESIGN OF ADVERTISING BROCHURES FOR OTHERS; DESIGN OF ADVERTISING FLYERS FOR OTHERS; DESIGN OF ADVERTISING MATERIALS FOR OTHERS; DESIGN OF INTERNET ADVERTISING; INTERNET ADVERTISING SERVICES; MARKETING AND BRANDING SERVICES, NAMELY, PERFORMING CONSUMER INSIGHT AND BRAND STRATEGY OF COMPANY LOGOS; ON-LINE ADVERTISING AND MARKETING SERVICES; ON-LINE ADVERTISING SERVICES FOR OTHERS; ON-LINE ART GALLERIES; ORGANIZATION OF EVENTS, EXHIBITIONS, FAIRS AND SHOWS FOR COMMERCIAL, PROMOTIONAL AND ADVERTISING PURPOSES; ORGANIZING, PROMOTING AND CONDUCTING EXHIBITIONS, TRADESHOWS AND EVENTS FOR BUSINESS PURPOSES; PLACING ADVERTISEMENTS FOR OTHERS; PREPARING AND PLACING ADVERTISEMENTS FOR OTHERS; PREPARING AND PLACING OF ADVERTISEMENTS; PREPARING AND PLACING OUTDOOR ADVERTISEMENTS FOR OTHERS; PRODUCTION AND DISTRIBUTION OF RADIO AND TELEVISION COMMERCIALS; PRODUCTION OF ADVERTISING MATTER AND COMMERCIALS; PRODUCTION OF FILM AND TELEVISION ADVERTISING; PRODUCTION OF TELEVISION COMMERCIALS AND PUBLIC SERVICE ANNOUNCEMENTS; PROMOTING THE GOODS AND SERVICES OF OTHERS BY MEANS OF DISTRIBUTING ADVERTISING ON THE INTERNET; PROMOTING THE GOODS AND SERVICES OF OTHERS BY PREPARING AND PLACING ADVERTISEMENTS IN AN ELECTRONIC MAGAZINE ACCESSED THROUGH A GLOBAL COMPUTER NETWORK; PROMOTING THE GOODS AND SERVICES OF OTHERS THROUGH ON-LINE ORDERING AND CATALOGING OF THOSE GOODS AND SERVICES; PROMOTING THE GRAPHIC ARTS DESIGN SERVICES OF OTHERS BY MEANS OF A WEBSITE FEATURING GRAPHIC ARTWORK SUBMITTED BY GRAPHIC ART DESIGNERS. PROMOTION AND MARKETING SERVICES AND RELATED CONSULTING; PUBLISHING OF ADVERTISING TEXTS; RESUME PREPARATION; RETAIL BOOK STORE SERVICES; THE BRINGING TOGETHER, FOR THE BENEFIT OF OTHERS, OF A VARIETY OF GOODS AND SERVICES, ENABLING CUSTOMERS TO CONVENIENTLY VIEW AND PURCHASE THOSE GOODS AND SERVICES FROM AN INTERNET WEB SITE PARTICULARLY SPECIALIZING IN THE MARKETING OF THE SALE OF GOODS AND SERVICES OF OTHERS (U.S. CLS. 100, 101 AND 102).

FIRST USE 1-9-2009; IN COMMERCE 7-27-2009.

#### CLASS 41—EDUCATION AND ENTERTAINMENT

FOR CONSULTING SERVICES IN THE FIELD OF PUBLICATION OF NEWSLETTERS; CUSTOM WRITING SERVICES; DESKTOP PUBLISHING FOR OTHERS; FILM AND VIDEO FILM PRODUCTION; FILM AND VIDEO PRODUCTION; FILM EDITING; MAGAZINE PUBLISHING; ONLINE ELECTRONIC PUBLISHING OF BOOKS AND PERIODICALS; PHOTO EDITING; PHOTOGRAPHIC AND VIDEO SERVICES, NAMELY, PHOTOGRAPHIC AND VIDEO CAPTURE; PRODUCTION OF AUDIO RECORDING; PRODUCTION OF SOUND AND MUSIC VIDEO RECORDINGS; PROFESSIONAL COACHING SERVICES IN THE FIELD OF WRITING, MARKETING AND SALES OF FICTION, NON-FICTION AND PICTURE BOOKS; PROOF READING OF MANUSCRIPTS; PROVIDING A WEB SITE FEATURING ON-LINE PUBLICATIONS IN THE FIELD OF NEWS ARTICLES FOR CHILDREN; PUBLICATION OF BOOKS; PUBLICATION OF BOOKS, OF MAGAZINES, OF JOUR-

NALS, OF NEWSPAPERS, OF PERIODICALS, OF CATALOGS, OF BROCHURES; PUBLICATION OF BOOKS, REVIEWS; PUBLICATION OF BROCHURES; PUBLICATION OF ELECTRONIC MAGAZINES; PUBLICATION OF LEAFLETS; PUBLICATION OF MAGAZINES; PUBLICATION OF PRINTED MATTER; PUBLISHING OF BOOKS AND REVIEWS; PUBLISHING OF BOOKS, E-BOOKS, AUDIO BOOKS, MUSIC AND ILLUSTRATIONS; PUBLISHING OF BOOKS, MAGAZINES; PUBLISHING OF ELECTRONIC PUBLICATIONS; PUBLISHING OF REVIEWS; PUBLISHING OF WEB MAGAZINES (U.S. CLS. 100, 101 AND 107).

FIRST USE 1-9-2009; IN COMMERCE 7-27-2009.

3,941,529. ANGELINAVAGABONDA GROUP, LLC, ROCHESTER, NY. SN 77-862,552. PUB. 4-6-2010, FILED 11-2-2009.

## Angelina Vagabonda

THE MARK CONSISTS OF STANDARD CHARACTERS WITHOUT CLAIM TO ANY PARTICULAR FONT, STYLE, SIZE, OR COLOR.

THE ENGLISH TRANSLATION OF "VAGABONDA" IN THE MARK IS "SHE TRAVELS". THE WORDING "ANGELINA" HAS NO MEANING IN A FOREIGN LANGUAGE.

### CLASS 18—LEATHER GOODS

FOR LEATHER HANDBAGS (U.S. CLS. 1, 2, 3, 22 AND 41).  
FIRST USE 7-24-2008; IN COMMERCE 7-24-2008.

### CLASS 29—MEATS AND PROCESSED FOODS

FOR APPETIZERS CONSISTING PRIMARILY OF CAPONATA (U.S. CL. 46).  
FIRST USE 11-1-2009; IN COMMERCE 11-12-2010.

3,941,530. KEELING&ASSOCIATES, LLC, NEW YORK, NY. SN 77-862,742. PUB. 3-30-2010, FILED 11-2-2009.

## Campus Change for Learning

THE MARK CONSISTS OF STANDARD CHARACTERS WITHOUT CLAIM TO ANY PARTICULAR FONT, STYLE, SIZE, OR COLOR.

### CLASS 35—ADVERTISING AND BUSINESS

FOR CONSULTING SERVICES IN THE FIELD OF MARKETING OF EDUCATIONAL TRAINING TO COLLEGES AND UNIVERSITIES (U.S. CLS. 100, 101 AND 102).

FIRST USE 11-15-2010; IN COMMERCE 11-15-2010.

### CLASS 41—EDUCATION AND ENTERTAINMENT

FOR CONSULTATION IN THE FIELD OF COLLEGE AND UNIVERSITY EDUCATIONAL SYSTEMS (U.S. CLS. 100, 101 AND 107).

FIRST USE 11-15-2010; IN COMMERCE 11-15-2010.

3,941,535. HOLMES, LAUREN L., TORONTO, ONTARIO, CANADA. SN 77-864,805. PUB. 4-13-2010, FILED 11-4-2009.

## FRONTIERING

THE MARK CONSISTS OF STANDARD CHARACTERS WITHOUT CLAIM TO ANY PARTICULAR FONT, STYLE, SIZE, OR COLOR.

### CLASS 9—ELECTRICAL AND SCIENTIFIC APPARATUS

FOR DIGITAL MATERIALS, NAMELY, PRE-RECORDED ELECTRONIC AND DIGITAL MEDIA, CDS, DVDS, DOWNLOADABLE SOUND RECORDINGS, DOWNLOADABLE AUDIO FILES, DOWNLOADABLE MULTIMEDIA FILES, DOWNLOADABLE WEBCASTS, AND DOWNLOADABLE PODCASTS, ALL FEATURING HUMAN DEVELOPMENT INFORMATION CONSISTING OF PERSONAL, PROFESSIONAL, LEADERSHIP, ORGANIZATIONAL, CAREER, HUMAN CAPITAL, STRATEGIC, ENTREPRENEURIAL, AND BUSINESS DEVELOPMENT PLUS PERFORMANCE IMPROVEMENT INFORMATION, NAMELY, INDIVIDUAL, GROUP, ORGANIZATIONAL, AND BUSINESS PERFORMANCE; DOWNLOADABLE ELECTRONIC PUBLICATIONS IN THE NATURE OF BROCHURES, BOOKLETS, NEWSLETTERS, TEACHING MATERIALS, COURSE MATERIALS, EXERCISES, FORMS, WORKBOOKS, TEXTBOOKS, TEACHER GUIDES, TRAINING MANUALS, TEXT FILES, ARTWORK, ONLINE DISCUSSION BOARDS, AND QUESTIONNAIRES IN THE FIELD OF HUMAN PERFORMANCE AND DEVELOPMENT CONSISTING OF PERSONAL, PROFESSIONAL, LEADERSHIP, ORGANIZATIONAL, CAREER, HUMAN CAPITAL, STRATEGIC, ENTREPRENEURIAL, AND BUSINESS DEVELOPMENT, AND INDIVIDUAL, GROUP, ORGANIZATIONAL, AND BUSINESS PERFORMANCE (U.S. CLS. 21, 23, 26, 36 AND 38).

FIRST USE 11-20-2001; IN COMMERCE 11-20-2001.

### CLASS 35—ADVERTISING AND BUSINESS

FOR BUSINESS ORGANIZATION AND MANAGEMENT CONSULTING SERVICES; BUSINESS CONSULTING IN THE FIELD OF IMPROVING BUSINESS PERFORMANCE; PROVIDING A WEBSITE FEATURING NON DOWNLOADABLE INFORMATION IN THE FIELD OF BUSINESS PERFORMANCE, BUSINESS ORGANIZATION, HUMAN RESOURCE MANAGEMENT, AND BUSINESS LEADERSHIP (U.S. CLS. 100, 101 AND 102).

FIRST USE 11-20-2001; IN COMMERCE 11-20-2001.

**CLASS 41—EDUCATION AND ENTERTAINMENT**

FOR EDUCATION SERVICES, NAMELY, PROVIDING CLASSES, SEMINARS, WEBINARS, WORKSHOPS, CLASSES FEATURING MULTI-MEDIA PRESENTATIONS, TELECONFERENCES, TELECLINICS, MENTORING, COACHING, AND PROFESSIONAL COACHING FEATURING BRAINSTORMING INSTRUCTION, ALL IN THE FIELDS OF HUMAN DEVELOPMENT, NAMELY, PERSONAL, PROFESSIONAL, LEADERSHIP, ORGANIZATIONAL, CAREER, HUMAN CAPITAL, STRATEGIC, ENTREPRENEURIAL, AND BUSINESS DEVELOPMENT (U.S. CLS. 100, 101 AND 107).

FIRST USE 11-20-2001; IN COMMERCE 11-20-2001.

**CLASS 45—PERSONAL AND LEGAL SERVICES**

FOR PERSONAL GROWTH AND MOTIVATION CONSULTING SERVICES; PROVIDING A WEBSITE FEATURING NON DOWNLOADABLE INFORMATION IN THE FIELD OF PERSONAL DEVELOPMENT, NAMELY, SELF-IMPROVEMENT, SELF-FULFILLMENT, AND INTERPERSONAL COMMUNICATION (U.S. CLS. 100 AND 101).

FIRST USE 11-20-2001; IN COMMERCE 11-20-2001.

**CLASS 9—ELECTRICAL AND SCIENTIFIC APPARATUS**

FOR ACCESSORIES FOR LIGHTING FIXTURES, NAMELY, PLASTIC POLE WITH ELECTRICAL SOURCE IN PROTECTIVE COVER; BAGS FOR CAMERAS AND PHOTOGRAPHIC EQUIPMENT; CASES FOR PHOTOGRAPHIC APPARATUS; COLLAPSIBLE LIGHT DIRECTORS AND DIFFUSERS FOR USE WITH PHOTOGRAPHIC LIGHTING EQUIPMENT FOR PROFESSIONAL AND HIGH-END PHOTOGRAPHY; ELECTRIC LIGHT DIMMERS; ELECTRIC LIGHT SWITCHES; ELECTRIC WARNING LIGHT SYSTEMS; ELECTRIC WARNING LIGHTS; ELECTRICAL LIGHTS FOR USE IN PROFESSIONAL QUALITY PHOTOGRAPHY; ELECTRONIC LED SIGNS; ELECTRONIC REGULATING AND CONTROL DEVICES FOR THE OPERATION OF LIGHT EMITTING DIODES; FLASHLIGHTS FOR USE IN PHOTOGRAPHY; FLASHLIGHTS WITH LIGHT EMITTING DIODES FOR USE IN PHOTOGRAPHY; LED AND HID LIGHT CONTROLS; LED CIRCUIT BOARDS; LIGHT DIODES; LIGHT DIRECTORS AND PHOTOGRAPHIC LIGHTING TENTS, ALL FOR USE WITH PHOTOGRAPHIC LIGHTING EQUIPMENT FOR PROFESSIONAL AND HIGH-END PHOTOGRAPHY; LIGHT EMITTING DIODE (LED) DISPLAYS; LIGHT EMITTING DIODES (LEDS); LIGHTING DEVICES FOR TAKING PICTURES; LIGHTING PANEL CONTROL BOARDS; LIGHTS FOR USE ON VIDEO CAMERAS; LUMINOUS VARIABLE/DYNAMIC SIGNS USING LIGHT EMITTING DIODES AND ELECTRONIC CONTROLLERS TO PRODUCE REAL-TIME AND PROGRAMMABLE MESSAGES AND INFORMATION DISPLAYS; PHOTOGRAPHIC EXPOSURE METERS; PHOTOGRAPHIC FILTERS; PHOTOGRAPHIC FLASH UNITS; PHOTOGRAPHIC FLASHBULBS; PORTABLE PHOTOGRAPHY EQUIPMENT, NAMELY, REFLECTORS, TRIPODS, LIGHT STANDS AND SUPPORTS AND BAGS SPECIALLY ADAPTED FOR THESE GOODS; RADIO RECEIVERS AND TRANSMITTERS FOR MONITORING AND CONTROLLING LIGHT EMITTING DIODES IN A NETWORK OF STREET LIGHTS AND FOR PROCESSING EMERGENCY SIGNALS TRANSMITTED TO INDIVIDUAL STREET LIGHTS; STANDS FOR PHOTOGRAPHIC APPARATUS; STROBE LIGHT APPARATUS FOR USE IN PROFESSIONAL QUALITY PHOTOGRAPHY (U.S. CLS. 21, 23, 26, 36 AND 38).

FIRST USE 7-11-2005; IN COMMERCE 3-11-2009.

3,941,549. LINCO INC., SANTA FE SPRINGS, CA. SN 77-868,620. PUB. 4-20-2010, FILED 11-9-2009.

**LINCOInc**

THE MARK CONSISTS OF STANDARD CHARACTERS WITHOUT CLAIM TO ANY PARTICULAR FONT, STYLE, SIZE, OR COLOR.

**CLASS 11—ENVIRONMENTAL CONTROL APPARATUS**

FOR FILTERS FOR PHOTOGRAPHIC, CINEMATOGRAPHIC, VIDEO AND PERFORMING ARTS LIGHTING; FLASHING STROBE LIGHT APPARATUS; FLAT PANEL LIGHTING APPARATUS; FLUORESCENT ELECTRIC LIGHT BULBS; FLUORESCENT LIGHTING TUBES; HALOGEN LIGHT BULBS; LED (LIGHT EMITTING DIODE) LIGHTING FIXTURES; LED LIGHT BULBS; LIGHT BULBS; LIGHT DIFFUSERS; LIGHT EMITTING DIODES (LEDS) INCORPORATED INTO METALLIC AND ADHESIVE PLASTIC REFLECTOR FILM FOR ILLUMINATING TRANSPARENT BALLOONS AND SIMILAR PRODUCTS; LIGHT REFLECTORS; LIGHTING FIXTURES THAT INTEGRATE NATURAL DAYLIGHT AND FLUORESCENT LIGHTING INTO THE FIXTURE; LIGHTING TUBES; PORTABLE BATTERY-OPERATED LIGHTS THAT CAN BE PLACED ON SURFACES WHERE OTHER LIGHT SOURCES ARE UNAVAILABLE; TELEVISION STUDIO LIGHTING APPARATUS; THEATRICAL STAGE LIGHTING APPARATUS (U.S. CLS. 13, 21, 23, 31 AND 34).

FIRST USE 7-11-2005; IN COMMERCE 7-20-2009.

3,941,554. INFINICYTE, LLC, LOS ANGELES, CA. SN 77-871,814. PUB. 6-1-2010, FILED 11-13-2009.

# INFINICYTE

THE MARK CONSISTS OF STANDARD CHARACTERS WITHOUT CLAIM TO ANY PARTICULAR FONT, STYLE, SIZE, OR COLOR.

## CLASS 9—ELECTRICAL AND SCIENTIFIC APPARATUS

FOR COMPUTER SOFTWARE AND DOWNLOADABLE SOFTWARE FOR USE WITH DATABASE MANAGEMENT AND IMAGE PROCESSING IN THE FIELD OF SCIENCE (U.S. CLS. 21, 23, 26, 36 AND 38).  
FIRST USE 9-0-2009; IN COMMERCE 9-0-2009.

## CLASS 42—SCIENTIFIC AND COMPUTER SERVICES

FOR COMPUTER SOFTWARE CONSULTATION; COMPUTER SOFTWARE DEVELOPMENT (U.S. CLS. 100 AND 101).  
FIRST USE 9-0-2009; IN COMMERCE 9-0-2009.

3,941,557. BRIGHTON CROMWELL LLC, RANDOLPH, NJ. SN 77-872,068. PUB. 4-20-2010, FILED 11-13-2009.

# SEDNA

THE MARK CONSISTS OF STANDARD CHARACTERS WITHOUT CLAIM TO ANY PARTICULAR FONT, STYLE, SIZE, OR COLOR.

## CLASS 35—ADVERTISING AND BUSINESS

FOR BUSINESS CONSULTATION SERVICES IN THE FIELDS OF SUPPLY CHAIN ANALYSIS, REGULATION COMPLIANCE AND COUNTERFEIT DETECTION; BUSINESS CONSULTING SERVICES RELATING TO PRODUCT DISTRIBUTION, OPERATIONS MANAGEMENT SERVICES, LOGISTICS, REVERSE LOGISTICS, SUPPLY CHAIN, AND PRODUCTION SYSTEMS AND DISTRIBUTION SOLUTIONS; BUSINESS MANAGEMENT SERVICES, NAMELY, MANAGING LOGISTICS, REVERSE LOGISTICS, SUPPLY CHAIN SERVICES, SUPPLY CHAIN VISIBILITY AND SYNCHRONIZATION, SUPPLY AND DEMAND FORECASTING AND PRODUCT DISTRIBUTION PROCESSES FOR OTHERS; BUSINESS MANAGEMENT SERVICES, NAMELY, SUPPLY CHAIN LOGISTICS, REVERSE LOGISTICS AND LIQUIDATION OF GOODS OF OTHERS; BUSINESS SERVICES, NAMELY, CONSULTING IN THE FIELD OF SUPPLY CHAIN VERIFICATION FOR THE PRESENCE OF GENETICALLY MODIFIED ORGANISMS; SUPPLY CHAIN MANAGEMENT SERVICES (U.S. CLS. 100, 101 AND 102).  
FIRST USE 11-14-2009; IN COMMERCE 11-14-2009.

## CLASS 39—TRANSPORTATION AND STORAGE

FOR SUPPLY CHAIN LOGISTICS AND REVERSE LOGISTICS SERVICES, NAMELY, STORAGE, TRANSPORTATION AND DELIVERY OF GOODS FOR OTHERS BY AIR, RAIL, SHIP OR TRUCK; SUPPLY CHAIN, LOGISTICS AND REVERSE LOGISTICS SERVICES, NAMELY, STORAGE, TRANSPORTATION AND DELIVERY OF DOCUMENTS, PACKAGES, RAW MATERIALS, AND OTHER FREIGHT FOR OTHERS BY AIR, RAIL, SHIP OR TRUCK (U.S. CLS. 100 AND 105).  
FIRST USE 11-14-2009; IN COMMERCE 11-14-2009.

3,941,558. BRIGHTON CROMWELL LLC, RANDOLPH, NJ. SN 77-872,079. PUB. 4-20-2010, FILED 11-13-2009.

# SEDNASearch

THE MARK CONSISTS OF STANDARD CHARACTERS WITHOUT CLAIM TO ANY PARTICULAR FONT, STYLE, SIZE, OR COLOR.

## CLASS 35—ADVERTISING AND BUSINESS

FOR BUSINESS CONSULTATION SERVICES IN THE FIELDS OF SUPPLY CHAIN ANALYSIS, REGULATION COMPLIANCE AND COUNTERFEIT DETECTION; BUSINESS CONSULTING SERVICES RELATING TO PRODUCT DISTRIBUTION, OPERATIONS MANAGEMENT SERVICES, LOGISTICS, REVERSE LOGISTICS, SUPPLY CHAIN, AND PRODUCTION SYSTEMS AND DISTRIBUTION SOLUTIONS; BUSINESS MANAGEMENT SERVICES, NAMELY, MANAGING LOGISTICS, REVERSE LOGISTICS, SUPPLY CHAIN SERVICES, SUPPLY CHAIN VISIBILITY AND SYNCHRONIZATION, SUPPLY AND DEMAND FORECASTING AND PRODUCT DISTRIBUTION PROCESSES FOR OTHERS; BUSINESS MANAGEMENT SERVICES, NAMELY, SUPPLY CHAIN LOGISTICS, REVERSE LOGISTICS AND LIQUIDATION OF GOODS OF OTHERS; BUSINESS SERVICES, NAMELY, CONSULTING IN THE FIELD OF SUPPLY CHAIN VERIFICATION FOR THE PRESENCE OF GENETICALLY MODIFIED ORGANISMS; SUPPLY CHAIN MANAGEMENT SERVICES (U.S. CLS. 100, 101 AND 102).  
FIRST USE 11-14-2009; IN COMMERCE 11-14-2009.

## CLASS 39—TRANSPORTATION AND STORAGE

FOR SUPPLY CHAIN LOGISTICS AND REVERSE LOGISTICS SERVICES, NAMELY, STORAGE, TRANSPORTATION AND DELIVERY OF GOODS FOR OTHERS BY AIR, RAIL, SHIP OR TRUCK; SUPPLY CHAIN, LOGISTICS AND REVERSE LOGISTICS SERVICES, NAMELY, STORAGE, TRANSPORTATION AND DELIVERY OF DOCUMENTS, PACKAGES, RAW MATERIALS, AND OTHER FREIGHT FOR OTHERS BY AIR, RAIL, SHIP OR TRUCK (U.S. CLS. 100 AND 105).  
FIRST USE 11-14-2009; IN COMMERCE 11-14-2009.

3,941,570. OTICON, INC., SOMERSET, NJ. SN 77-876,186. PUB. 4-20-2010, FILED 11-19-2009.

3,941,587. HUMANTECH, INC., ANN ARBOR, MI. SN 77-879,488. PUB. 4-27-2010, FILED 11-24-2009.

# REVEAL

THE MARK CONSISTS OF STANDARD CHARACTERS WITHOUT CLAIM TO ANY PARTICULAR FONT, STYLE, SIZE, OR COLOR.

## CLASS 10—MEDICAL APPARATUS

FOR HEARING AIDS AND REPLACEMENT PARTS THEREFOR (U.S. CLS. 26, 39 AND 44).  
FIRST USE 11-15-2010; IN COMMERCE 11-15-2010.

## CLASS 44—MEDICAL, BEAUTY AND AGRICULTURAL SERVICES

FOR HEARING AID SERVICES (U.S. CLS. 100 AND 101).  
FIRST USE 11-15-2010; IN COMMERCE 11-15-2010.

---

3,941,579. JOHNSON, ODYSSEUS, WILMETTE, IL. SN 77-878,297. PUB. 5-18-2010, FILED 11-22-2009.

# Chicago Blues All Stars

THE MARK CONSISTS OF STANDARD CHARACTERS WITHOUT CLAIM TO ANY PARTICULAR FONT, STYLE, SIZE, OR COLOR.

NO CLAIM IS MADE TO THE EXCLUSIVE RIGHT TO USE "CHICAGO" FOR INTERNATIONAL CLASS 25 AND "CHICAGO BLUES" FOR INTERNATIONAL CLASS 41, APART FROM THE MARK AS SHOWN.

## CLASS 25—CLOTHING

FOR CLOTHING, NAMELY, JACKETS, SWEAT-SHIRTS, SWEATERS, T-SHIRTS, SHIRTS, PANTS, CAPS, HATS, SCARFS AND BELTS (U.S. CLS. 22 AND 39).  
FIRST USE 4-10-2007; IN COMMERCE 1-10-2011.

## CLASS 41—EDUCATION AND ENTERTAINMENT

FOR ENTERTAINMENT, NAMELY, LIVE MUSIC CONCERTS AND PERFORMANCES BY A MUSICAL GROUP; ENTERTAINMENT SERVICES, NAMELY, PROVIDING ENTERTAINMENT INFORMATION ABOUT A RECORDING ARTIST VIA AN ONLINE NETWORK IN THE NATURE OF PROVIDING A WEBSITE FEATURING NON-DOWNLOADABLE MUSICAL PERFORMANCES, NON-DOWNLOADABLE MUSIC, SONG AND VIDEO SAMPLE CLIPS, PICTURES, TOUR INFORMATION, BIOGRAPHIES AND INFORMATION ABOUT PERSONAL APPEARANCES FOR ENTERTAINMENT PURPOSES (U.S. CLS. 100, 101 AND 107).  
FIRST USE 4-10-2007; IN COMMERCE 1-12-2010.

# ERGOPOINT

THE MARK CONSISTS OF STANDARD CHARACTERS WITHOUT CLAIM TO ANY PARTICULAR FONT, STYLE, SIZE, OR COLOR.

## CLASS 9—ELECTRICAL AND SCIENTIFIC APPARATUS

FOR COMPUTER SOFTWARE FOR SURVEYING, TRACKING, STUDYING AND MANAGING ERGONOMICS PROGRAMS IN WORK ENVIRONMENTS; DATABASE MANAGEMENT SOFTWARE FOR SURVEYING, TRACKING STUDYING AND MANAGING ERGONOMICS PROGRAMS IN WORK ENVIRONMENTS (U.S. CLS. 21, 23, 26, 36 AND 38).  
FIRST USE 11-13-2009; IN COMMERCE 6-23-2010.

## CLASS 41—EDUCATION AND ENTERTAINMENT

FOR EDUCATIONAL SERVICES, NAMELY, CONDUCTING SEMINARS, CLASSES, WORKSHOPS AND EDUCATIONAL PROGRAMS IN THE FIELD OF ERGONOMICS AND DISTRIBUTION OF TRAINING MATERIAL IN CONNECTION THEREWITH (U.S. CLS. 100, 101 AND 107).  
FIRST USE 11-13-2009; IN COMMERCE 6-23-2010.

## CLASS 42—SCIENTIFIC AND COMPUTER SERVICES

FOR CONSULTATION IN THE FIELD OF ERGONOMICS, NAMELY, DESIGNING WORKPLACE FACILITIES AND EQUIPMENT TO OPTIMIZE EFFICIENCY AND SAFETY; PROVIDING TEMPORARY USE OF A WEB-BASED SOFTWARE APPLICATION FOR SURVEYING, TRACKING, STUDYING AND MANAGING ERGONOMICS PROGRAMS IN WORK ENVIRONMENTS (U.S. CLS. 100 AND 101).  
FIRST USE 11-13-2009; IN COMMERCE 6-23-2010.

---

3,941,590. URBANOVSKY, MATT, TAMPA, FL. SN 77-879,685. PUB. 8-3-2010, FILED 11-24-2009.



THE MARK CONSISTS OF AN ORNATE SHIELD, WHEREIN SAID SHIELD HAS A PLACARD DISPLAYED ACROSS THE UPPER PORTION OF SAID SHIELD AND



THE TERM "URBANO" IS DISPLAYED IN SAID PLACARD. POSITIONED BELOW AND CENTERED BENEATH SAID PLACARD IS A FLEUR-DE-LIS BOUND BY A CROWN. SURROUNDING SAID FLEUR-DE-LIS AND SAID CROWN ARE FIVE STARS. POSITIONED AROUND THE BOTTOM PORTION OF SAID SHIELD IS A RIBBON-LIKE BANNER.

THE ENGLISH TRANSLATION OF "URBANO" IN THE MARK IS URBAN.

#### CLASS 16—PAPER GOODS AND PRINTED MATTER

FOR CIGAR BANDS (U.S. CLS. 2, 5, 22, 23, 29, 37, 38 AND 50).

FIRST USE 11-30-2010; IN COMMERCE 11-30-2010.

#### CLASS 34—SMOKERS' ARTICLES

FOR TOBACCO, TOBACCO PRODUCTS AND TOBACCO ACCESSORIES, NAMELY, CIGARS; CIGARILLOS; CIGAR CUTTERS; CIGARETTES; CIGAR ROLLING PAPERS; CIGARETTES CONTAINING TOBACCO SUBSTITUTES NOT FOR MEDICAL PURPOSES; SMOKING TOBACCO; TOBACCO POUCHES; TOBACCO SPITTOONS; TOBACCO PIPES; SNUFF BOXES, NOT OF PRECIOUS METAL; SMOKELESS TOBACCO; PIPE TOBACCO, CHEWING AND SNUFF TOBACCO; SMOKING PIPES; SMOKING PIPE CLEANERS; TOBACCO PIPE CLEANERS; SMOKING PIPE RACKS; SMOKING URNS; CIGARETTE FILTERS; CIGAR FILTERS; TOBACCO FILTERS; HUMIDORS; CIGARETTE HOLDERS, NOT OF PRECIOUS METAL; CIGARETTE CASES, NOT OF PRECIOUS METAL; CIGAR CASES, NOT OF PRECIOUS METAL; CIGAR HOLDERS, NOT OF PRECIOUS METAL; CIGARETTE FILTER TIPS; BOOKS OF CIGARETTE PAPERS; POCKET MACHINES FOR ROLLING CIGARETTES; ABSORBENT PAPER FOR TOBACCO PIPES; MOUTHPIECES OF YELLOW AMBER FOR CIGAR AND CIGARETTE HOLDERS; MOUTHPIECES FOR CIGARETTE HOLDERS; CIGAR TUBES; MATCHES; MATCH BOXES, NOT OF PRECIOUS METAL; MATCH HOLDERS, NOT OF PRECIOUS METAL; LIGHTERS FOR SMOKERS; CIGAR LIGHTERS AND CIGARETTE LIGHTERS, NOT FOR LAND VEHICLES; LIQUEFIED GAS CONTAINERS FOR CIGAR LIGHTERS; LIGHTER FLINTS; NON-ELECTRIC CIGAR LIGHTERS, NOT OF PRECIOUS METAL; CIGARETTE LIGHTERS NOT OF PRECIOUS METAL; AND ASHTRAYS, NOT OF PRECIOUS METAL (U.S. CLS. 2, 8, 9 AND 17).

FIRST USE 11-30-2010; IN COMMERCE 11-30-2010.

3,941,591. WHOLE FOODS MARKET IP, L.P., AUSTIN, TX. SN 77-879,835. PUB. 6-8-2010, FILED 11-24-2009.



OWNER OF U.S. REG. NOS. 1,557,320, 2,987,639, AND OTHERS.

NO CLAIM IS MADE TO THE EXCLUSIVE RIGHT TO USE "FOODS MARKET", "RESPONSIBLY FARMED" OR "3RD PARTY VERIFIED", APART FROM THE MARK AS SHOWN.

THE MARK CONSISTS OF THE WORDS "RESPONSIBLY FARMED" STACKED ON A BANNER BENEATH A DESIGN OF A FISH AND ABOVE THE WORDS "3RD PARTY VERIFIED", ALL ON A CIRCULAR BACKGROUND WITH ZIG-ZAG EDGES. THE WORD "VERIFIED" IS DEPICTED BETWEEN TWO STAR DESIGNS, AND BENEATH THE WORDS "3RD PARTY". THE OWNER'S REGISTERED HOUSE MARK "WHOLE FOODS MARKET" IS DEPICTED ATOP THE WORDS "RESPONSIBLY FARMED".

#### CLASS 29—MEATS AND PROCESSED FOODS

FOR SEAFOOD; FISH; FROZEN PREPARED DINNERS, ENTREES AND SIDE DISHES CONSISTING PRIMARILY OF FISH, SEAFOOD, MEAT, OR VEGETABLES (U.S. CL. 46).

FIRST USE 7-0-2010; IN COMMERCE 7-0-2010.

#### CLASS 35—ADVERTISING AND BUSINESS

FOR RETAIL GROCERY STORE SERVICES; PROMOTING PUBLIC AWARENESS OF ENVIRONMENTALLY-RESPONSIBLE SEAFOOD FARMING PRACTICES AND THE NEED TO SUPPORT SUCH PRACTICES (U.S. CLS. 100, 101 AND 102).

FIRST USE 1-0-2010; IN COMMERCE 1-0-2010.

3,941,592. GROUP360, INC., ST. LOUIS, MO. SN 77-880,015. PUB. 7-27-2010, FILED 11-24-2009.

### GROUP360 WORLDWIDE

THE MARK CONSISTS OF STANDARD CHARACTERS WITHOUT CLAIM TO ANY PARTICULAR FONT, STYLE, SIZE, OR COLOR.

OWNER OF U.S. REG. NOS. 2,743,286 AND 2,743,312.

NO CLAIM IS MADE TO THE EXCLUSIVE RIGHT TO USE "WORLDWIDE", APART FROM THE MARK AS SHOWN.

#### CLASS 35—ADVERTISING AND BUSINESS

FOR DESIGN OF ADVERTISING MATERIALS FOR OTHERS AND PREPARING PROMOTIONAL MATERIALS FOR OTHERS FOR USE IN MARKETING CAMPAIGNS USED AT TRADE SHOWS, BUSINESS-TO-BUSINESS EVENTS, AND BUSINESS-TO-CONSUMER EVENTS; CREATING CORPORATE AND BRAND IDENTITY FOR OTHERS (U.S. CLS. 100, 101 AND 102).

FIRST USE 12-0-2010; IN COMMERCE 12-0-2010.

#### CLASS 39—TRANSPORTATION AND STORAGE

FOR STORAGE OF ELECTRONIC MEDIA, NAMELY, DIGITAL IMAGES, FOR OTHERS (U.S. CLS. 100 AND 105).

FIRST USE 12-0-2010; IN COMMERCE 12-0-2010.

#### CLASS 40—MATERIAL TREATMENT

FOR PRINTING SERVICES, NAMELY, PRINTING ADVERTISING MATERIALS FOR OTHERS (U.S. CLS. 100, 103 AND 106).

FIRST USE 12-0-2010; IN COMMERCE 12-0-2010.

**CLASS 41—EDUCATION AND ENTERTAINMENT**

FOR PHOTOGRAPHY SERVICES (U.S. CLS. 100, 101 AND 107).  
FIRST USE 12-0-2010; IN COMMERCE 12-0-2010.

**CLASS 42—SCIENTIFIC AND COMPUTER SERVICES**

FOR PACKAGING DESIGN FOR OTHERS; WEBSITE DESIGN AND DEVELOPMENT FOR OTHERS (U.S. CLS. 100 AND 101).  
FIRST USE 12-0-2010; IN COMMERCE 12-0-2010.

SHOWN.

THE ENGLISH TRANSLATION OF "ACCESSOIRE" IN THE MARK IS "ACCESSORY".

**CLASS 24—FABRICS**

FOR BLANKET THROWS; LAP BLANKETS (U.S. CLS. 42 AND 50).  
FIRST USE 7-0-2010; IN COMMERCE 7-0-2010.

**CLASS 25—CLOTHING**

FOR GLOVES; HEADWEAR (U.S. CLS. 22 AND 39).  
FIRST USE 7-0-2010; IN COMMERCE 7-0-2010.

3,941,603. EXPORTADORA PRIZE LIMITADA, REQUINOA, RANCAGUA, CHILE. SN 77-882,373. PUB. 12-7-2010, FILED 11-30-2009.



THE COLOR(S) BLUE, ORANGE, AND GREEN IS/ARE CLAIMED AS A FEATURE OF THE MARK.

THE MARK CONSISTS OF THE WORD "PRIZE" APPEARING IN THE COLOR BLUE, WHEREIN A CIRCLE APPEARING IN THE COLOR ORANGE ENCIRCLES THE LETTER "E" OF THE WORD "PRIZE", AND TWO LEAVES APPEARING IN THE COLOR GREEN EXTEND UPWARD FROM THE TOP OF THE ORANGE CIRCLE.

**CLASS 31—NATURAL AGRICULTURAL PRODUCTS**

FOR FRESH FRUITS AND VEGETABLES (U.S. CLS. 1 AND 46).  
FIRST USE 1-16-2006; IN COMMERCE 1-16-2006.

**CLASS 35—ADVERTISING AND BUSINESS**

FOR IMPORT AND EXPORT SERVICES FOR FRESH FRUITS AND VEGETABLES; RETAIL STORE SERVICES FEATURING FRESH FRUITS AND VEGETABLES; AND PROMOTIONAL MARKETING AND REPRESENTATION FOR SALES OF FRESH FRUITS AND VEGETABLES (U.S. CLS. 100, 101 AND 102).

FIRST USE 1-16-2006; IN COMMERCE 1-16-2006.

3,941,613. 360SWEATER COMPANY, LLC, SANTA MONICA, CA. SN 77-884,236. PUB. 6-8-2010, FILED 12-2-2009.

**360 ACCESSOIRE**

THE MARK CONSISTS OF STANDARD CHARACTERS WITHOUT CLAIM TO ANY PARTICULAR FONT, STYLE, SIZE, OR COLOR.

NO CLAIM IS MADE TO THE EXCLUSIVE RIGHT TO USE "ACCESSOIRE", APART FROM THE MARK AS

3,941,616. IPG INTERNATIONAL PRODUCTS GROUP INC, DORAL, FL. SN 77-884,761. PUB. 5-4-2010, FILED 12-2-2009.



NO CLAIM IS MADE TO THE EXCLUSIVE RIGHT TO USE "DESIGN", APART FROM THE MARK AS SHOWN.

THE COLOR(S) YELLOW, BLACK, ORANGE AND WHITE IS/ARE CLAIMED AS A FEATURE OF THE MARK.

THE MARK CONSISTS OF FOUR SQUARE BOXES; THE FIRST BOX CONTAINS A CAPITAL "N" IN BLACK AND THE REST OF THE BOX IS ORANGE. THE SECOND BOX CONTAINS A CAPITAL "Y" IN BLACK AND THE REST OF THE BOX IS YELLOW. THE THIRD BOX CONTAINS A CAPITAL "C" IN BLACK AND THE REST OF THE BOX IS ORANGE. THE FOURTH BOX CONTAINS A CAPITAL "K" IN BLACK AND THE REST OF THE BOX IS YELLOW. TO THE RIGHT OF THE FOURTH BOX IS AN IMAGE OF A KANGAROO. THE KANGAROO'S BODY IS ORANGE AND THE HEAD IS YELLOW. THE TAIL OF THE KANGAROO EXTENDS INTO THE FOURTH BOX. THERE IS A BABY KANGAROO HEAD WHOSE COLOR IS YELLOW THAT IS STICKING OUT OF THE KANGAROO'S POUCH. UNDERNEATH THE FOUR BOXES AND THE KANGAROO THERE IS A THICK ORANGE BAR THAT CONTAINS TEXT IN WHITE FONT STARTING AT THE BEGINNING OF THE FOURTH BOX AND ENDING AT THE KANGAROO THAT SAYS "INNOVATION DESIGN"

**CLASS 9—ELECTRICAL AND SCIENTIFIC APPARATUS**

FOR CARRYING CASES FOR MOBILE COMPUTERS; COMPUTER BAGS; LAPTOP CARRYING CASES; MOUSE PADS; MOUSEPADS; NEOPRENE LAPTOP COVERS; NOTEBOOK COMPUTER CARRYING CASES (U.S. CLS. 21, 23, 26, 36 AND 38).

FIRST USE 9-2-2010; IN COMMERCE 9-2-2010.

**CLASS 18—LEATHER GOODS**

FOR ALL PURPOSE SPORT BAGS; ALL-PURPOSE ATHLETIC BAGS; ALL-PURPOSE CARRYING BAGS; BACKPACKS, BOOK BAGS, SPORTS BAGS, BUM BAGS, WALLETS AND HANDBAGS; CARRY-ALL BAGS; CARRY-ON BAGS; FASHION HANDBAGS; HANDBAGS; PURSES; SPORTS BAGS (U.S. CLS. 1, 2, 3, 22 AND 41).

FIRST USE 9-2-2010; IN COMMERCE 9-2-2010.

**CLASS 25—CLOTHING**

FOR SHOES (U.S. CLS. 22 AND 39).  
FIRST USE 9-2-2010; IN COMMERCE 9-2-2010.

3,941,625. DRG INTERNATIONAL, INC., MOUNTAINSIDE,  
NJ. SN 77-889,554. PUB. 9-7-2010, FILED 12-9-2009.

3,941,619. COMPUTER CHROME, INC., DBA SIGHT MAR-  
KETING, MINNEAPOLIS, MN. SN 77-886,708. PUB. 11-  
30-2010, FILED 12-4-2009.

**SIGHT MARKETING**

THE MARK CONSISTS OF STANDARD CHARACTERS  
WITHOUT CLAIM TO ANY PARTICULAR FONT, STYLE,  
SIZE, OR COLOR.

NO CLAIM IS MADE TO THE EXCLUSIVE RIGHT TO  
USE "MARKETING", APART FROM THE MARK AS  
SHOWN.

**CLASS 35—ADVERTISING AND BUSINESS**

FOR ADVERTISING AND ADVERTISEMENT SER-  
VICES; ADVERTISING AND BUSINESS MANAGEMENT  
CONSULTANCY; ADVERTISING AND MARKETING  
SERVICES; MARKETING CONSULTING SERVICES  
(U.S. CLS. 100, 101 AND 102).

FIRST USE 9-1-2008; IN COMMERCE 9-1-2008.

**CLASS 42—SCIENTIFIC AND COMPUTER SERVICES**

FOR CREATING, DESIGNING AND MAINTAINING  
WEB SITES FOR OTHERS; DESIGN AND DEVELOP-  
MENT OF MULTIMEDIA PRODUCTS (U.S. CLS. 100  
AND 101).

FIRST USE 9-1-2008; IN COMMERCE 9-1-2008.

3,941,624. DRG INTERNATIONAL, INC., MOUNTAINSIDE,  
NJ. SN 77-889,523. PUB. 9-7-2010, FILED 12-9-2009.

**DRG:HYBRID-XL**

THE MARK CONSISTS OF STANDARD CHARACTERS  
WITHOUT CLAIM TO ANY PARTICULAR FONT, STYLE,  
SIZE, OR COLOR.

**CLASS 9—ELECTRICAL AND SCIENTIFIC APPARATUS**

FOR IMMUNOASSAY ANALYZERS PRIMARILY FOR  
SCIENTIFIC RESEARCH PURPOSES (U.S. CLS. 21, 23, 26,  
36 AND 38).

FIRST USE 11-18-2009; IN COMMERCE 7-27-2010.

**CLASS 10—MEDICAL APPARATUS**

FOR IMMUNOASSAY ANALYZERS PRIMARILY FOR  
MEDICAL DIAGNOSTIC USE (U.S. CLS. 26, 39 AND 44).

FIRST USE 11-18-2009; IN COMMERCE 7-27-2010.

**HYBRID-XL**

THE MARK CONSISTS OF STANDARD CHARACTERS  
WITHOUT CLAIM TO ANY PARTICULAR FONT, STYLE,  
SIZE, OR COLOR.

**CLASS 9—ELECTRICAL AND SCIENTIFIC APPARATUS**

FOR IMMUNOASSAY ANALYZERS PRIMARILY FOR  
SCIENTIFIC RESEARCH PURPOSES (U.S. CLS. 21, 23, 26,  
36 AND 38).

FIRST USE 11-18-2009; IN COMMERCE 7-27-2010.

**CLASS 10—MEDICAL APPARATUS**

FOR IMMUNOASSAY ANALYZERS PRIMARILY FOR  
MEDICAL DIAGNOSTIC USE (U.S. CLS. 26, 39 AND 44).

FIRST USE 11-18-2009; IN COMMERCE 7-27-2010.

3,941,630. BOOT BARN, INC., ORANGE, CA. SN 77-891,409.  
PUB. 5-18-2010, FILED 12-11-2009.

**AMERICAN WORKER HEAD TO TOE WORK WEAR**

THE MARK CONSISTS OF STANDARD CHARACTERS  
WITHOUT CLAIM TO ANY PARTICULAR FONT, STYLE,  
SIZE, OR COLOR.

OWNER OF U.S. REG. NO. 3,696,624.

NO CLAIM IS MADE TO THE EXCLUSIVE RIGHT TO  
USE "AMERICAN" AND "WORK WEAR", APART FROM  
THE MARK AS SHOWN.

**CLASS 25—CLOTHING**

FOR CLOTHING, NAMELY, SHIRTS, WESTERN  
SHIRTS, CASUAL SHIRTS, WESTERN DRESS PANTS,  
WESTERN CASUAL PANTS, JACKETS, VESTS, ROBES,  
JEANS, CASUAL PANTS (NON-WESTERN), SHORTS,  
PAJAMAS, SKIRTS, OVERALLS, COVERALLS, T-  
SHIRTS, DRESSES, TIES; FOOTWEAR, NAMELY, WES-  
TERN AND WORK BOOTS, COWBOY BOOTS, MOCCA-  
SINS AND SHOES, SOCKS; OUTERWEAR, NAMELY,  
DUSTERS, COATS AND JACKETS; WESTERN HATS  
AND CAPS; ACCESSORIES, NAMELY, WESTERN, UTI-  
LITY AND CASUAL BELTS (U.S. CLS. 22 AND 39).

FIRST USE 2-15-2009; IN COMMERCE 2-15-2009.

**CLASS 35—ADVERTISING AND BUSINESS**

FOR RETAIL STORE AND COMPUTER ON-LINE  
RETAIL STORE SERVICES FEATURING CLOTHING,  
NAMELY, MEN'S AND WOMEN'S WORK AND CASUAL  
CLOTHING, WESTERN WEAR, SHIRTS, JEANS, PANTS,  
OUTER WEAR, FOOTWEAR, GLOVES, HATS AND  
SOCKS; MAIL ORDER CATALOG SERVICES FEATUR-  
ING WESTERN WEAR (U.S. CLS. 100, 101 AND 102).

FIRST USE 2-15-2009; IN COMMERCE 2-15-2009.

3,941,639. PATIENT SAFETY ORGANIZATION ONE, INC., DBA PSO ONE, INC., BATTLE CREEK, MI. SN 77-893,500. PUB. 6-8-2010, FILED 12-15-2009.

3,941,664. CORE3 SOLUTIONS LLC, BIRMINGHAM, MI. SN 77-897,101. PUB. 5-11-2010, FILED 12-18-2009.



NO CLAIM IS MADE TO THE EXCLUSIVE RIGHT TO USE "PSO" AND "SIMULATION COMPANY", APART FROM THE MARK AS SHOWN.

THE MARK CONSISTS OF A STYLIZED CIRCLE AND THE WORDING "PSO ONE THE INSIGHTFUL SIMULATION COMPANY".

#### CLASS 35—ADVERTISING AND BUSINESS

FOR BUSINESS CONSULTING SERVICES, NAMELY, RISK ASSESSMENT AND BUSINESS LIABILITY RISK ASSESSMENT CONSULTATION IN THE FIELD OF HEALTH CARE (U.S. CLS. 100, 101 AND 102).  
FIRST USE 12-4-2009; IN COMMERCE 12-4-2009.

#### CLASS 41—EDUCATION AND ENTERTAINMENT

FOR TRAINING SERVICES, NAMELY, CONDUCTING TRAINING SESSIONS, SEMINARS AND WORKSHOPS IN THE FIELD OF HEALTH CARE (U.S. CLS. 100, 101 AND 107).  
FIRST USE 12-4-2009; IN COMMERCE 12-4-2009.

---

3,941,660. SOCIAL GAMING NETWORK, INC., PALO ALTO, CA. SN 77-895,602. PUB. 5-18-2010, FILED 12-17-2009.

# EXOPLANET

THE MARK CONSISTS OF STANDARD CHARACTERS WITHOUT CLAIM TO ANY PARTICULAR FONT, STYLE, SIZE, OR COLOR.

#### CLASS 9—ELECTRICAL AND SCIENTIFIC APPARATUS

FOR COMPUTER GAME SOFTWARE FOR MOBILE COMMUNICATION DEVICES (U.S. CLS. 21, 23, 26, 36 AND 38).  
FIRST USE 4-0-2010; IN COMMERCE 4-0-2010.

#### CLASS 41—EDUCATION AND ENTERTAINMENT

FOR PROVIDING ONLINE APPLICATION-BASED COMPUTER GAMES FEATURING MULTIPLAYER FUNCTIONALITY (U.S. CLS. 100, 101 AND 107).  
FIRST USE 4-0-2010; IN COMMERCE 4-0-2010.

# CORE3

THE MARK CONSISTS OF STANDARD CHARACTERS WITHOUT CLAIM TO ANY PARTICULAR FONT, STYLE, SIZE, OR COLOR.

#### CLASS 37—CONSTRUCTION AND REPAIR

FOR INSTALLATION OF COMPUTER NETWORKS (U.S. CLS. 100, 103 AND 106).  
FIRST USE 9-21-2002; IN COMMERCE 9-21-2002.

#### CLASS 42—SCIENTIFIC AND COMPUTER SERVICES

FOR COMPUTER SERVICES, NAMELY, REMOTE AND ON-SITE MANAGEMENT OF THE INFORMATION TECHNOLOGY (IT) SYSTEMS OF OTHERS; COMPUTER SOFTWARE INSTALLATION AND MAINTENANCE; DESIGN, CREATION, HOSTING, MAINTENANCE OF WEBSITES FOR OTHERS; WEB SITE HOSTING SERVICES (U.S. CLS. 100 AND 101).  
FIRST USE 9-21-2002; IN COMMERCE 9-21-2002.

---

3,941,675. UGA DIGITAL INC., TAIPEI CITY 115, TAIWAN. SN 77-898,154. PUB. 5-18-2010, FILED 12-21-2009.

THE MARK CONSISTS OF THE HIGHLY STYLIZED LETTERS "ARCHER", WITH THE CROSSBAR OF THE STYLIZED LETTER "A" IN THE FORM OF A HORIZONTALLY DIRECTED ARROW HEAD EXTENDING EXTERNAL TO THE STYLIZED LETTER "A".

**CLASS 9—ELECTRICAL AND SCIENTIFIC APPARATUS**

FOR COMPUTER SOFTWARE FOR USE IN DATABASE MANAGEMENT; COMPUTER SOFTWARE FOR UPLOADING, MANIPULATING, AND ENHANCING DIGITAL CONTENT, DOCUMENTS, PHOTOGRAPHS, IMAGES, VIDEO, AND AUDIO; COMPUTER SOFTWARE FOR LINKING METADATA TAGS WITH PHOTOGRAPHIC AND OTHER MEDIA FILES TO ENABLE SEARCH ENGINE RETRIEVAL AND DATABASE SOFTWARE COLLECTIONS OF FILES AND THEIR ON-LINE SHARING, AND FOR LINKING METADATA TAGS WITH WEB PAGES VISITED, TO CREATE LINKS WHICH USERS CAN MAINTAIN FOR THEMSELVES AND SHARE WITH ON-LINE GROUPS AND WEBSITE TAGGING; SOFTWARE TO ENABLE UPLOADING, POSTING, SHOWING, DISPLAYING, TAGGING, BLOGGING, SHARING OR OTHERWISE PROVIDING ELECTRONIC MEDIA OR INFORMATION OVER THE INTERNET OR OTHER COMMUNICATIONS NETWORK; APPLICATION PROGRAMMING INTERFACE (API) FOR THIRD-PARTY SOFTWARE AND ONLINE SERVICES FOR SOCIAL NETWORKING, BUILDING SOCIAL NETWORKING APPLICATIONS AND FOR ALLOWING DATA RETRIEVAL, UPLOAD, ACCESS AND MANAGEMENT; DIGITAL IMAGING SOFTWARE; COMPUTER SOFTWARE FOR PHOTOGRAPHIC AND IMAGE PROCESSING; PORTABLE AND HANDHELD DIGITAL ELECTRONIC DEVICES FOR RECORDING, ORGANIZING, TRANSMITTING, RECEIVING, MANIPULATING, PLAYING AND REVIEWING TEXT, DATA, IMAGE, AUDIO AND VIDEO FILES, NAMELY, PORTABLE COMPUTERS, ULTRA MOBILE PERSONAL COMPUTER (UMPC), SMART PHONES, PERSONAL DIGITAL ASSISTANTS (PDA), DIGITAL PHOTO FRAMES, MOBILE INTERNET DEVICES; COMPUTER SOFTWARE FOR USE IN ORGANIZING, TRANSMITTING, RECEIVING, MANIPULATING, PLAYING AND REVIEWING TEXT, DATA, IMAGE, AUDIO, AND VIDEO FILES ON PORTABLE AND HANDHELD DIGITAL ELECTRONIC DEVICES; COMPUTER APPLICATION SOFTWARE FOR RECORDING AND ORGANIZING CALENDARS AND SCHEDULES, TO-DO LISTS, AND CONTACT INFORMATION; COMPUTER SOFTWARE AND PRERECORDED COMPUTER PROGRAMS FOR PERSONAL INFORMATION MANAGEMENT, DATABASE MANAGEMENT SOFTWARE, ELECTRONIC MAIL AND MESSAGING SOFTWARE; DATABASE SYNCHRONIZATION SOFTWARE, COMPUTER PROGRAMS FOR ACCESSING, BROWSING AND SEARCHING ONLINE DATABASES; ELECTRONIC ADVERTISEMENT AND MESSAGING DISPLAY UNIT WITH MULTI-NETWORKING (TCP/IP) CAPABILITIES AND REMOTE CONNECTIVITY (U.S. CLS. 21, 23, 26, 36 AND 38).

FIRST USE 12-10-2009; IN COMMERCE 12-10-2009.

**CLASS 42—SCIENTIFIC AND COMPUTER SERVICES**

FOR APPLICATION SERVICE PROVIDER (ASP) FEATURING SOFTWARE TO ENABLE UPLOADING, POSTING, SHOWING, DISPLAYING, TAGGING, BLOGGING, SHARING OR OTHERWISE PROVIDING ELECTRONIC MEDIA OR INFORMATION OVER THE INTERNET OR OTHER COMMUNICATIONS NETWORK; PROVIDING TEMPORARY USE OF NON-DOWNLOADABLE SOFTWARE APPLICATIONS FOR CLASSIFIEDS, VIRTUAL COMMUNITY, SOCIAL NETWORKING, PHOTO SHARING, VIDEO SHARING, AND TRANSMISSION OF PHOTOGRAPHIC IMAGES; HOSTING OF DIGITAL CONTENT, IMAGES AND VIDEO ON THE INTERNET; COMPUTER SERVICES, NAMELY, HOSTING ONLINE WEB FACILITIES FOR OTHERS FOR ORGANIZING AND CONDUCTING ONLINE MEETINGS, GATHERINGS, AND INTERACTIVE DISCUSSIONS; COMPUTER SERVICES IN THE NATURE OF CUSTOMIZED WEB PAGES FEATURING USER-DEFINED INFORMATION, PERSONAL PROFILES AND INFORMATION (U.S. CLS. 100 AND 101).

FIRST USE 12-10-2009; IN COMMERCE 12-10-2009.

3,941,681. PROPARK, INC., HARTFORD, CT. SN 77-898,844. PUB. 6-15-2010, FILED 12-22-2009.

**ELECTRIC VEHICLE JUICE BAR**

THE MARK CONSISTS OF STANDARD CHARACTERS WITHOUT CLAIM TO ANY PARTICULAR FONT, STYLE, SIZE, OR COLOR.

NO CLAIM IS MADE TO THE EXCLUSIVE RIGHT TO USE "ELECTRIC VEHICLE", APART FROM THE MARK AS SHOWN.

**CLASS 9—ELECTRICAL AND SCIENTIFIC APPARATUS**

FOR ELECTRIC VEHICLE CHARGING STATIONS LOCATED IN PARKING GARAGES (U.S. CLS. 21, 23, 26, 36 AND 38).

FIRST USE 10-20-2008; IN COMMERCE 1-16-2009.

**CLASS 37—CONSTRUCTION AND REPAIR**

FOR PARKING GARAGE SERVICES, NAMELY, PROVIDING ELECTRIC VEHICLE CHARGING STATIONS IN PARKING GARAGES (U.S. CLS. 100, 103 AND 106).

FIRST USE 10-20-2008; IN COMMERCE 1-16-2009.

3,941,682. PROPARK, INC., HARTFORD, CT. SN 77-898,890. PUB. 6-15-2010, FILED 12-22-2009.

**JUICE BAR CHARGING STATION**

THE MARK CONSISTS OF STANDARD CHARACTERS WITHOUT CLAIM TO ANY PARTICULAR FONT, STYLE, SIZE, OR COLOR.

NO CLAIM IS MADE TO THE EXCLUSIVE RIGHT TO USE "CHARGING STATION", APART FROM THE MARK AS SHOWN.

**CLASS 9—ELECTRICAL AND SCIENTIFIC APPARATUS**

FOR ELECTRIC VEHICLE CHARGING STATIONS LOCATED IN PARKING GARAGES (U.S. CLS. 21, 23, 26, 36 AND 38).

FIRST USE 10-20-2008; IN COMMERCE 1-16-2009.

**CLASS 37—CONSTRUCTION AND REPAIR**

FOR PARKING GARAGE SERVICES, NAMELY, PROVIDING ELECTRIC VEHICLE CHARGING STATIONS IN PARKING GARAGES (U.S. CLS. 100, 103 AND 106).

FIRST USE 10-20-2008; IN COMMERCE 1-16-2009.

3,941,686. SKINIT, INC., SAN DIEGO, CA. SN 77-899,212.  
PUB. 10-26-2010, FILED 12-22-2009.

## MAKE IT YOURS

THE MARK CONSISTS OF STANDARD CHARACTERS WITHOUT CLAIM TO ANY PARTICULAR FONT, STYLE, SIZE, OR COLOR.

### CLASS 9—ELECTRICAL AND SCIENTIFIC APPARATUS

FOR PRE-MADE AND CUSTOM-MADE VINYL AND PLASTIC SHELL COVERS FOR CELL PHONES, MP3 PLAYERS, LAPTOPS, COMPUTERS, PORTABLE GAME MACHINES, PORTABLE SATELLITE RADIOS, PERSONAL DIGITAL ASSISTANTS, REMOTE CONTROLS AND TELEVISION SATELLITE RECORDERS (U.S. CLS. 21, 23, 26, 36 AND 38).

FIRST USE 12-1-2010; IN COMMERCE 12-1-2010.

### CLASS 40—MATERIAL TREATMENT

FOR CUSTOM IMPRINTING OF CELL PHONES, MP3 PLAYERS, LAPTOPS, COMPUTERS, PORTABLE GAME MACHINES, PORTABLE SATELLITE RADIOS, PERSONAL DIGITAL ASSISTANTS, REMOTE CONTROLS, MEDICAL DEVICES, CAR AND TRUCK EXTERIORS, WALLPAPER, CAR DECORATIONS, AND TELEVISION SATELLITE RECORDERS WITH CUSTOM-MADE VINYL COVERS, AND PAINTED PLASTIC SHELLS (U.S. CLS. 100, 103 AND 106).

FIRST USE 12-1-2010; IN COMMERCE 12-1-2010.

3,941,693. ALLIED ADVERTISING LIMITED PARTNERSHIP, BOSTON, MA. SN 77-900,150. PUB. 6-22-2010, FILED 12-23-2009.

## BuzzBo

THE MARK CONSISTS OF STANDARD CHARACTERS WITHOUT CLAIM TO ANY PARTICULAR FONT, STYLE, SIZE, OR COLOR.

### CLASS 35—ADVERTISING AND BUSINESS

FOR PROVIDING INFORMATION ABOUT AND MAKING REFERRALS IN THE FIELD OF CONSUMER PRODUCTS AND SERVICES FOR RETAIL SERVICES CONCERNING PRODUCTS, SERVICES, EVENTS, ACTIVITIES, ATTRACTIONS AND FACILITIES RELATING TO LEISURE ACTIVITIES, ARTS, CULTURE, ENTERTAINMENT, SPORTS AND RECREATION IN PARTICULAR GEOGRAPHIC LOCATIONS BY MEANS OF A GLOBAL COMPUTER NETWORK (U.S. CLS. 100, 101 AND 102).

FIRST USE 6-22-2010; IN COMMERCE 6-22-2010.

### CLASS 41—EDUCATION AND ENTERTAINMENT

FOR PROVIDING INFORMATION IN THE FIELDS OF RECREATION AND LEISURE ACTIVITIES, ARTS, SPORTS, CULTURAL AND ENTERTAINMENT PRODUCTIONS, CULTURAL AND ENTERTAINMENT EVENTS, CULTURAL AND ENTERTAINMENT EXHIBITIONS, ALL BY MEANS OF A GLOBAL COMPUTER NETWORK (U.S. CLS. 100, 101 AND 107).

FIRST USE 6-22-2010; IN COMMERCE 6-22-2010.

### CLASS 42—SCIENTIFIC AND COMPUTER SERVICES

FOR COMPUTER SERVICES, NAMELY, PROVIDING CUSTOMIZED ON-LINE WEB PAGES FEATURING USER-DEFINED INFORMATION, WHICH INCLUDES SEARCH ENGINES AND ON-LINE WEB LINKS TO OTHER WEB SITES; SEARCHING AND RETRIEVING INFORMATION, SITES, AND OTHER RESOURCES AVAILABLE ON COMPUTER NETWORKS FOR OTHERS (U.S. CLS. 100 AND 101).

FIRST USE 6-22-2010; IN COMMERCE 6-22-2010.

3,941,709. LV3, LLC, BELLEFONTAINE, OH. SN 77-903,022.  
PUB. 5-25-2010, FILED 12-30-2009.



THE MARK CONSISTS OF AN UPPERCASE, SCRIPT LETTER "L" SUPERIMPOSED OVER AN UPPERCASE, SCRIPT LETTER "V".

### CLASS 9—ELECTRICAL AND SCIENTIFIC APPARATUS

FOR SPORTS GOGGLES AND EYEGLASSES (U.S. CLS. 21, 23, 26, 36 AND 38).

FIRST USE 1-1-2010; IN COMMERCE 1-1-2010.

### CLASS 25—CLOTHING

FOR APPAREL, NAMELY, HATS; PANTS, SHIRTS AND JACKETS (U.S. CLS. 22 AND 39).

FIRST USE 11-30-2009; IN COMMERCE 11-30-2009.

### CLASS 41—EDUCATION AND ENTERTAINMENT

FOR ENTERTAINMENT SERVICES, NAMELY, PROVIDING A WEB SITE FEATURING INFORMATION, PHOTOGRAPHS, NON-DOWNLOADABLE VIDEOS, NEWS AND UPDATES ABOUT SNOWBOARDING AND SNOWBOARDER LOUIE VITO (U.S. CLS. 100, 101 AND 107).

FIRST USE 8-17-2009; IN COMMERCE 8-17-2009.

3,941,713. NAPOLEON, ANDRA, LANOKA HARBOR, NJ.  
SN 77-903,487. PUB. 4-13-2010, FILED 12-31-2009.

3,941,740. PHOTOMISSION, INC., WEST CHESTER, PA. SN  
77-908,918. PUB. 6-8-2010, FILED 1-11-2010.



THE MARK CONSISTS OF A CIRCLE HAVING TWO PERPENDICULAR LINES ACROSS ITS CENTER.

#### CLASS 14—JEWELRY

FOR BEADS FOR USE IN THE MANUFACTURE OF JEWELRY; JEWELRY (U.S. CLS. 2, 27, 28 AND 50).  
FIRST USE 5-15-2010; IN COMMERCE 5-15-2010.

#### CLASS 25—CLOTHING

FOR SHORT-SLEEVED OR LONG-SLEEVED T-SHIRTS; T-SHIRTS (U.S. CLS. 22 AND 39).  
FIRST USE 2-7-2010; IN COMMERCE 2-7-2010.

#### CLASS 45—PERSONAL AND LEGAL SERVICES

FOR DATING SERVICES (U.S. CLS. 100 AND 101).  
FIRST USE 10-14-2010; IN COMMERCE 10-14-2010.

3,941,727. JOSH SUHRE DESIGN, LLC, CINCINNATI, OH.  
SN 77-906,540. PUB. 5-4-2010, FILED 1-6-2010.

# OPERATIV

THE MARK CONSISTS OF STANDARD CHARACTERS WITHOUT CLAIM TO ANY PARTICULAR FONT, STYLE, SIZE, OR COLOR.

#### CLASS 18—LEATHER GOODS

FOR ALL PURPOSE SPORT BAGS; ATTACHE CASES; BACKPACKS; HANDBAGS; MESSENGER BAGS; SUITCASES; TRAVEL BAGS; WALLETS (U.S. CLS. 1, 2, 3, 22 AND 41).  
FIRST USE 9-23-2010; IN COMMERCE 12-3-2010.

#### CLASS 25—CLOTHING

FOR BANDANAS; BELTS; CAPS; GLOVES; HATS; JACKETS; PANTS; SHIRTS; SHOES; SHORTS; SOCKS; SWEAT SHIRTS (U.S. CLS. 22 AND 39).  
FIRST USE 9-23-2010; IN COMMERCE 12-3-2010.

## SUPPLYING GOD'S PEOPLE WITH PHOTOS OF HIS WORLD

THE MARK CONSISTS OF STANDARD CHARACTERS WITHOUT CLAIM TO ANY PARTICULAR FONT, STYLE, SIZE, OR COLOR.

#### CLASS 35—ADVERTISING AND BUSINESS

FOR ON-LINE RETAIL STORE SERVICES FEATURING PHOTOGRAPHIC IMAGES (U.S. CLS. 100, 101 AND 102).  
FIRST USE 9-8-2010; IN COMMERCE 9-8-2010.

#### CLASS 41—EDUCATION AND ENTERTAINMENT

FOR ENTERTAINMENT SERVICES, NAMELY, PROVIDING A WEB SITE FEATURING INSPIRATIONAL PHOTOGRAPHS; EDUCATIONAL SERVICES IN THE NATURE OF PHOTOGRAPHY TRAINING; EDUCATIONAL SERVICES, NAMELY, CONDUCTING CLASSES, SEMINARS, CONFERENCES, WORKSHOPS IN THE FIELD OF PHOTOGRAPHY AND DISTRIBUTING COURSE MATERIALS IN CONNECTION THEREWITH; CONDUCTING ON-LINE EXHIBITIONS AND DISPLAYS AND INTERACTIVE EXHIBITS IN THE FIELD OF PHOTOGRAPHY; ORGANIZING EXHIBITIONS FOR EDUCATIONAL, CULTURAL AND ENTERTAINMENT PURPOSES IN THE FIELD OF PHOTOGRAPHY; ARRANGING AND CONDUCTING EDUCATIONAL CONFERENCES; EDUCATIONAL DEMONSTRATIONS; EDUCATIONAL RESEARCH (U.S. CLS. 100, 101 AND 107).  
FIRST USE 9-8-2010; IN COMMERCE 9-8-2010.

3,941,748. HUTCH MEDIA, LLC, SANTA MONICA, CA. SN  
77-910,959. PUB. 8-17-2010, FILED 1-13-2010.

## MAKE YOUR MARK

THE MARK CONSISTS OF STANDARD CHARACTERS WITHOUT CLAIM TO ANY PARTICULAR FONT, STYLE, SIZE, OR COLOR.

#### CLASS 35—ADVERTISING AND BUSINESS

FOR ADVERTISING SERVICES, NAMELY, DISSEMINATION OF VIDEO ADVERTISEMENTS AND VIDEO COMMERCIAL PROMOTIONS VIA THE INTERNET, BROADBAND TV, VIDEO PODCAST AND VIDEO BLOG; ADVERTISING THE GOODS AND SERVICES OF OTHERS VIA CABLE, BROADBAND TV, PODCAST, VIDEO BLOG (U.S. CLS. 100, 101 AND 102).  
FIRST USE 8-31-2007; IN COMMERCE 8-31-2007.

**CLASS 41—EDUCATION AND ENTERTAINMENT**

FOR PRODUCTION OF VIDEO AND WEBSITE MATERIAL FOR INTERNET TELEVISION, BROADBAND TV, VIDEO PODCAST, VIDEO BLOG; DOMESTIC AND INTERNATIONAL DISTRIBUTION OF VIDEO PROGRAMMING VIA THE INTERNET, BROADBAND; PRODUCTION AND DISTRIBUTION OF VIDEO PROGRAMS VIA THE INTERNET, BROADBAND, VIDEO PODCAST, VIDEO BLOG; BROADCASTING AND TRANSMISSION OF INTERNET TV, BROADBAND TV, VIDEO PODCAST, VIDEO BLOG, AND VIDEO WEBCASTING SERVICES (U.S. CLS. 100, 101 AND 107).

FIRST USE 8-31-2007; IN COMMERCE 8-31-2007.

3,941,752. THOMAS III, TERRANCE R., SEATTLE, WA. SN 77-911,383. PUB. 6-1-2010, FILED 1-13-2010.

**BATTLEFIELD TO BUSINESS**

THE MARK CONSISTS OF STANDARD CHARACTERS WITHOUT CLAIM TO ANY PARTICULAR FONT, STYLE, SIZE, OR COLOR.

**CLASS 9—ELECTRICAL AND SCIENTIFIC APPARATUS**

FOR AUDIO AND VIDEO RECORDINGS FEATURING THE FIELD OF PERSONAL IMPROVEMENT (U.S. CLS. 21, 23, 26, 36 AND 38).

FIRST USE 1-16-2010; IN COMMERCE 1-16-2010.

**CLASS 41—EDUCATION AND ENTERTAINMENT**

FOR EDUCATIONAL SERVICES, NAMELY, CONDUCTING CLASSES AND SEMINARS IN THE FIELD OF PERSONAL IMPROVEMENT (U.S. CLS. 100, 101 AND 107).

FIRST USE 1-16-2010; IN COMMERCE 1-16-2010.

3,941,758. PACIFIC COAST FEATHER COMPANY, SEATTLE, WA. SN 77-912,125. PUB. 4-13-2010, FILED 1-14-2010.

**LUXEFILL**

THE MARK CONSISTS OF STANDARD CHARACTERS WITHOUT CLAIM TO ANY PARTICULAR FONT, STYLE, SIZE, OR COLOR.

**CLASS 20—FURNITURE AND ARTICLES NOT OTHERWISE CLASSIFIED**

FOR FILL SOLD AS A COMPONENT OF PILLOWS (U.S. CLS. 2, 13, 22, 25, 32 AND 50).

FIRST USE 1-25-2009; IN COMMERCE 1-25-2009.

**CLASS 24—FABRICS**

FOR FILL SOLD AS A COMPONENT OF COMFORTERS (U.S. CLS. 42 AND 50).

FIRST USE 1-25-2009; IN COMMERCE 1-25-2009.

3,941,761. WHIT, LLC, NEW YORK, NY. SN 77-912,953. PUB. 6-1-2010, FILED 1-15-2010.

**WHIT**

THE MARK CONSISTS OF STANDARD CHARACTERS WITHOUT CLAIM TO ANY PARTICULAR FONT, STYLE, SIZE, OR COLOR.

**CLASS 18—LEATHER GOODS**

FOR LEATHER BAGS AND WALLETS; LEATHER HANDBAGS (U.S. CLS. 1, 2, 3, 22 AND 41).

FIRST USE 12-15-2010; IN COMMERCE 12-15-2010.

**CLASS 25—CLOTHING**

FOR BLOUSES; DENIM JACKETS; DENIMS; DRESS SUITS; JACKETS; LADIES' SUITS; LEATHER BELTS; MEN'S AND WOMEN'S JACKETS, COATS, TROUSERS, VESTS; MEN'S SUITS, WOMEN'S SUITS; PANTS; SWEATERS; TROUSERS; WOMEN'S TOPS, NAMELY, CAMIS (U.S. CLS. 22 AND 39).

FIRST USE 12-15-2010; IN COMMERCE 12-15-2010.

3,941,765. REALTYINFUSION.COM, INC., SEMINOLE, FL. SN 77-913,193. PUB. 5-18-2010, FILED 1-15-2010.

**REALTY INFUSION**

THE MARK CONSISTS OF STANDARD CHARACTERS WITHOUT CLAIM TO ANY PARTICULAR FONT, STYLE, SIZE, OR COLOR.

NO CLAIM IS MADE TO THE EXCLUSIVE RIGHT TO USE "REALTY", APART FROM THE MARK AS SHOWN.

**CLASS 36—INSURANCE AND FINANCIAL**

FOR REAL ESTATE CONSULTATION; PROVIDING AN INTERNET WEBSITE PORTAL OFFERING INFORMATION IN THE FIELDS OF REAL ESTATE CONCERNING THE PURCHASING SALE OF NEW AND RESALE HOMES AND CONDOS; PROVIDING INFORMATION IN THE FIELD OF REAL ESTATE BY MEANS OF LINKING THE WEBSITE TO OTHER WEBSITES FEATURING REAL ESTATE INFORMATION (U.S. CLS. 100, 101 AND 102).

FIRST USE 1-0-2010; IN COMMERCE 1-0-2010.



**CLASS 42—SCIENTIFIC AND COMPUTER SERVICES**

FOR PROVIDING A WEBSITE FEATURING TEMPORARY USE OF ON-LINE NON-DOWNLOADABLE SOFTWARE FOR ENABLING USERS TO PROCESS REAL ESTATE TRANSACTIONS (U.S. CLS. 100 AND 101).  
FIRST USE 1-0-2010; IN COMMERCE 1-0-2010.

3,941,771. GARMIN SWITZERLAND GMBH, SCHAFFHAUSEN, SWITZERLAND. SN 77-914,070. PUB. 8-31-2010, FILED 1-18-2010.

# GARMINFONE

THE MARK CONSISTS OF STANDARD CHARACTERS WITHOUT CLAIM TO ANY PARTICULAR FONT, STYLE, SIZE, OR COLOR.

OWNER OF U.S. REG. NOS. 3,468,532, 3,468,553, AND OTHERS.

**CLASS 9—ELECTRICAL AND SCIENTIFIC APPARATUS**

FOR SATELLITE NAVIGATION SYSTEMS, NAMELY, A GLOBAL POSITIONING SYSTEM (GPS); ELECTRONIC NAVIGATIONAL DEVICES, NAMELY, GLOBAL POSITIONING SATELLITE (GPS) BASED NAVIGATION RECEIVERS; PORTABLE COMMUNICATION DEVICES, NAMELY, WIRELESS TELEPHONES; PRE-RECORDED CARTRIDGES FEATURING DIGITAL MAP DATA AND SOFTWARE FOR FACILITATING USE OF GPS BASED NAVIGATION RECEIVERS, RADIO TRANSCEIVERS AND WIRELESS TELEPHONE; GLOBAL POSITIONING SYSTEMS COMPRISED OF COMPUTERS, TRANSMITTERS, NETWORK INTERFACE DEVICES, GPS RECEIVERS, ANTENNAS, AND A LCD DISPLAY; AUTOMOBILE NAVIGATION APPARATUS FEATURING GPS RECEIVERS, DIGITAL MAP DISPLAYS AND TURN-BY-TURN INSTRUCTIONS; GPS RECEIVERS; PORTABLE GPS DEVICES, NAMELY, ELECTRONIC INSTRUMENTS FOR DETERMINING AND OUTPUTTING POSITION AND SPEED; WIRELESS COMMUNICATIONS RADIOS; WIRELESS COMMUNICATIONS RADIOS FEATURING A GPS RECEIVER; PERSONAL DIGITAL ASSISTANTS FEATURING A GPS RECEIVER AND ELECTRONIC MAPS; SATELLITE RADIO RECEIVERS; ELECTRONIC STORAGE MEDIA, NAMELY, CARDS CONTAINING MAP DATA; AND NAVIGATION SOFTWARE FOR CALCULATING AND DISPLAYING ROUTE; THEFT DETERRENT SOFTWARE SOLD AS A COMPONENT OF GLOBAL POSITIONING SYSTEM (GPS) UNIT; COMPUTER SOFTWARE TO ENABLE THE RECEPTION OF MAPPING, NAVIGATION, TRAFFIC, WEATHER AND POINT-OF-INTEREST INFORMATION VIA TELECOMMUNICATIONS NETWORKS, CELLULAR TELEPHONES AND NAVIGATION DEVICES SOLD AS A COMPONENT OF A GLOBAL POSITIONING SYSTEM UNIT; COMPUTER SOFTWARE FOR THE MARKING AND UPLOADING OF INFORMATION ABOUT PLACES OF INTEREST TO A GLOBAL POSITIONING SYSTEM, AND RETRIEVAL OF THIS INFORMATION VIA AUDIO TRANSMISSION AND VISUAL DISPLAY, SOLD AS A COMPONENT OF A GLOBAL POSITIONING SYSTEM UNIT; ELECTRONIC PORTABLE PERSONAL NAVIGATION DEVICES; ELECTRONIC PORTABLE PERSONAL NAVIGATION DEVICES FEATURING TRAVEL GUIDE FEATURES, LANGUAGE TRANSLATION FEATURES, DICTIONARY FEATURES AND AUDIBLE BOOK-PLAYER FEATURES; COMPUTER SOFTWARE, NAMELY, AN APPLICATION ALLOWING ENHANCED SATELLITE ACQUISITION, SOLD AS A COMPONENT PART OF A GLOBAL POSITIONING SYSTEM (GPS); HANDHELD GLOBAL POSITIONING SYSTEM (GPS) CONSISTING OF

COMPUTERS, COMPUTER SOFTWARE, TRANSMITTERS, RECEIVERS AND NETWORK INTERFACE DEVICES; ELECTRIC CABLES; BATTERY PACKS; ANTENNAS; PROTECTIVE CARRYING CASES FOR GPS UNITS (U.S. CLS. 21, 23, 26, 36 AND 38).  
FIRST USE 6-0-2010; IN COMMERCE 6-0-2010.

**CLASS 38—COMMUNICATION**

FOR TRANSMISSION OF A GLOBAL POSITIONING SYSTEM USER'S LOCATION TO OTHERS VIA TELECOMMUNICATION AND GLOBAL COMMUNICATION NETWORKS; TELECOMMUNICATIONS AND INFORMATION TECHNOLOGY SERVICES, NAMELY, TRANSMISSION OF VOICE, DATA, IMAGES, AUDIO, VIDEO, AND INFORMATION VIA TELEPHONE, AND GLOBAL COMMUNICATION NETWORKS; PROVIDING MULTIPLE-USER ACCESS TO A GLOBAL COMMUNICATIONS NETWORK (U.S. CLS. 100, 101 AND 104).  
FIRST USE 6-0-2010; IN COMMERCE 6-0-2010.

**CLASS 39—TRANSPORTATION AND STORAGE**

FOR PROVIDING MAPS, NAVIGATION, TRAFFIC AND GEOGRAPHIC POINT-OF-INTEREST INFORMATION VIA TELECOMMUNICATION NETWORKS, CELLULAR TELEPHONES AND WIRELESS NAVIGATION (U.S. CLS. 100 AND 105).  
FIRST USE 6-0-2010; IN COMMERCE 6-0-2010.

**CLASS 42—SCIENTIFIC AND COMPUTER SERVICES**

FOR PROVIDING WEATHER INFORMATION VIA TELECOMMUNICATION NETWORKS, CELLULAR TELEPHONES AND WIRELESS NAVIGATION DEVICES (U.S. CLS. 100 AND 101).  
FIRST USE 6-0-2010; IN COMMERCE 6-0-2010.

3,941,798. PAR TECHNOLOGY CORPORATION, NEW HARTFORD, NY. SN 77-918,997. PUB. 6-15-2010, FILED 1-25-2010.



OWNER OF U.S. REG. NO. 3,686,108.  
THE MARK CONSISTS OF A PINEAPPLE TOP POSITIONED ADJACENT THE WORD "PAR".

**CLASS 9—ELECTRICAL AND SCIENTIFIC APPARATUS**

FOR COMPUTER SOFTWARE FOR PROCESSING POINT OF SALE TRANSACTIONS AND FOR OPERATION OF POINT OF SALE TERMINALS AND COMPUTER HARDWARE ALL FOR USE IN POINT OF SALE TRANSACTIONS AND OPERATIONS MANAGEMENT IN THE HOSPITALITY AND RESTAURANT MARKETS (U.S. CLS. 21, 23, 26, 36 AND 38).  
FIRST USE 1-1-2008; IN COMMERCE 1-1-2008.

**CLASS 42—SCIENTIFIC AND COMPUTER SERVICES**

FOR TECHNICAL CONSULTING AND ASSISTANCE WITH COMPUTER-BASED INFORMATION SYSTEMS AND COMPONENTS (U.S. CLS. 100 AND 101).  
FIRST USE 1-1-2008; IN COMMERCE 1-1-2008.

**CLASS 43—HOTEL AND RESTAURANT SERVICES**

FOR CONSULTING SERVICES IN THE FIELD OF HOSPITALITY (U.S. CLS. 100 AND 101).  
FIRST USE 1-1-2008; IN COMMERCE 1-1-2008.

3,941,799. PAR TECHNOLOGY CORPORATION, NEW HARTFORD, NY. SN 77-918,999. PUB. 6-15-2010, FILED 1-25-2010.



OWNER OF U.S. REG. NO. 3,686,108.

THE MARK CONSISTS OF A PAIR OF CONCENTRIC OVALS THAT ARE OPEN AT THEIR TOPS AND WITH AN "E" POSITIONED IN THE OPENING AND THAT IS POSITION TO THE LEFT OF A PINEAPPLE TOP POSITIONED ADJACENT THE WORD "PAR" WHICH, IN TURN, IS POSITIONED ABOVE THE WORD "EVERSERV".

**CLASS 9—ELECTRICAL AND SCIENTIFIC APPARATUS**

FOR COMPUTER SOFTWARE FOR PROCESSING POINT OF SALE TRANSACTIONS AND FOR OPERATION OF POINT OF SALE TERMINALS AND COMPUTER HARDWARE ALL FOR USE IN POINT OF SALE TRANSACTIONS AND OPERATIONS MANAGEMENT IN THE HOSPITALITY AND RESTAURANT MARKETS (U.S. CLS. 21, 23, 26, 36 AND 38).  
FIRST USE 1-1-2009; IN COMMERCE 1-1-2009.

**CLASS 42—SCIENTIFIC AND COMPUTER SERVICES**

FOR TECHNICAL CONSULTING AND ASSISTANCE WITH COMPUTER-BASED INFORMATION SYSTEMS AND COMPONENTS (U.S. CLS. 100 AND 101).  
FIRST USE 1-1-2009; IN COMMERCE 1-1-2009.

**CLASS 43—HOTEL AND RESTAURANT SERVICES**

FOR CONSULTING SERVICES IN THE FIELD OF HOSPITALITY (U.S. CLS. 100 AND 101).  
FIRST USE 1-1-2009; IN COMMERCE 1-1-2009.

3,941,818. METRO MARKETING GROUP, INC., TENAFLY, NJ. SN 77-920,397. PUB. 6-8-2010, FILED 1-26-2010.



NO CLAIM IS MADE TO THE EXCLUSIVE RIGHT TO USE "ORGANIZATION", APART FROM THE MARK AS

SHOWN.

THE MARK CONSISTS OF CONCENTRIC OVALS WITH THE WORDS "DESTINATION ORGANIZATION" IN THE CENTER AND IMAGES OF STARS ON BOTH SIDES.

**CLASS 16—PAPER GOODS AND PRINTED MATTER**

FOR DESK BASKETS FOR DESK ACCESSORIES; DESK FILE TRAYS; DESK MOUNTED STATIONERY CABINETS; DESK SETS; DESKTOP STATIONERY CABINETS; FILE POCKETS; HOLDERS FOR DESK ACCESSORIES; ORGANIZERS FOR STATIONERY USE; PORTABLE DESKS; STATIONERY; STATIONERY BOXES; STATIONERY CASES (U.S. CLS. 2, 5, 22, 23, 29, 37, 38 AND 50).  
FIRST USE 7-0-2009; IN COMMERCE 7-0-2009.

**CLASS 20—FURNITURE AND ARTICLES NOT OTHERWISE CLASSIFIED**

FOR BOOK RESTS; CLOSET ACCESSORIES, NAMELY, CLOTHES BARS; CLOSET ACCESSORIES, NAMELY, SHOE RACKS; CLOTHES HANGERS; HAMPERS; MAGAZINE RACKS; NON-METAL BINS; NON-METAL FABRIC HANGING ORGANIZER; NON-METAL FABRIC STORAGE BIN ORGANIZER; SHOE RACKS; TIE RACKS; WRITING DESKS (U.S. CLS. 2, 13, 22, 25, 32 AND 50).  
FIRST USE 7-0-2009; IN COMMERCE 7-0-2009.

3,941,826. MEANS, STEPHEN PHILIP, DBA WISDOMGAME VIDEOS, NORTHRIDGE, CA. SN 77-921,287. PUB. 6-15-2010, FILED 1-27-2010.

Wisdomgame

THE MARK CONSISTS OF STANDARD CHARACTERS WITHOUT CLAIM TO ANY PARTICULAR FONT, STYLE, SIZE, OR COLOR.  
OWNER OF U.S. REG. NO. 2,980,397.

**CLASS 9—ELECTRICAL AND SCIENTIFIC APPARATUS**

FOR AUDIO AND VIDEO RECORDINGS FEATURING ARTISTIC PERFORMANCES, MUSIC AND SPIRITUAL ENLIGHTENMENT; CHILDREN'S VIDEO TAPES; COMPUTER GAME PROGRAMS; COMPUTER GAME SOFTWARE DOWNLOADABLE FROM A GLOBAL COMPUTER NETWORK; COMPUTER GAME SOFTWARE FOR PERSONAL COMPUTERS, HOME VIDEO GAME CONSOLES; DIGITAL MEDIA, NAMELY, PRE-RECORDED VIDEO CASSETTES, DOWNLOADABLE AUDIO AND VIDEO RECORDINGS AND DVDS FEATURING ARTISTIC PERFORMANCES, MUSIC AND SPIRITUAL ENLIGHTENMENT; DIGITAL MEDIA, NAMELY, DOWNLOADABLE AUDIO FILES FEATURING ARTISTIC PERFORMANCES, MUSIC AND SPIRITUAL ENLIGHTENMENT; DOWNLOADABLE ELECTRONIC NEWSLETTERS IN THE FIELD OF ARTISTIC PERFORMANCES, MUSIC AND SPIRITUAL ENLIGHTENMENT; DOWNLOADABLE FILMS AND TELEVISION PROGRAMS FEATURING ARTISTIC PERFORMANCES, MUSIC AND SPIRITUAL ENLIGHTENMENT; DOWNLOADABLE MOTION PICTURES AND TELEVISION SHOWS ABOUT ARTISTIC PERFORMANCES, MUSIC AND SPIRITUAL ENLIGHTENMENT; DOWNLOADABLE MUSICAL SOUND RECORDINGS; GAME SOFTWARE; INTERACTIVE GAME SOFTWARE; INTERACTIVE VIDEO GAME PROGRAMS; MULTIMEDIA SOFTWARE RECORDED ON CD-ROM FEATURING ARTISTIC PERFORMANCES, MUSIC AND SPIRITUAL ENLIGHTENMENT; VIDEO AND COMPUTER GAME PROGRAMS; VIDEO GAME SOFTWARE (U.S. CLS. 21, 23, 26, 36 AND 38).

FIRST USE 6-5-2002; IN COMMERCE 2-16-2010.

**CLASS 41—EDUCATION AND ENTERTAINMENT**

FOR ARRANGING AND CONDUCTING LIVE, INTERACTIVE, TREASURE HUNT GAMING ADVENTURES; EDUCATION IN THE FIELD OF EPISTEMOLOGY RENDERED THROUGH VIDEO CONFERENCE; EDUCATIONAL AND ENTERTAINMENT SERVICES, NAMELY, A CONTINUING PROGRAM ABOUT WISDOM AND INTERNET CONNECTABILITY ACCESSIBLE BY RADIO, TELEVISION, SATELLITE, AUDIO, VIDEO AND COMPUTER NETWORKS; ELECTRONIC PUBLISHING SERVICES, NAMELY, PUBLICATION OF TEXT AND GRAPHIC WORKS OF OTHERS ON ARTISTIC PERFORMANCES, MUSIC AND SPIRITUAL ENLIGHTENMENT FEATURING ARTISTS, ENTERTAINERS AND TEACHERS; ENTERTAINMENT AND EDUCATION SERVICES IN THE NATURE OF A SERIES OF SHORT SHOWS FEATURING ARTISTIC PERFORMANCES, MUSIC AND SPIRITUAL ENLIGHTENMENT DISTRIBUTED TO MOBILE HANDSETS, WHICH MAY INCLUDE VIDEO, TEXT, PHOTOS, ILLUSTRATIONS OR HYPERTEXT; ENTERTAINMENT AND EDUCATIONAL SERVICES, NAMELY, PROVIDING ADVICE AND INFORMATION FOR MUSIC, VIDEO AND FILM CONCEPT AND SCRIPT DEVELOPMENT; ENTERTAINMENT SERVICES, NAMELY, PROVIDING A WEB SITE FEATURING NON-DOWNLOADABLE MUSICAL PERFORMANCES, MUSICAL VIDEOS, RELATED FILM CLIPS, PHOTOGRAPHS, AND OTHER MULTIMEDIA MATERIALS FEATURING TOP ARTISTS; ENTERTAINMENT SERVICES, NAMELY, PROVIDING A WEB SITE FEATURING PHOTOGRAPHIC, AUDIO, VIDEO AND PROSE PRESENTATIONS FEATURING ARTISTIC PERFORMANCES, MUSIC AND SPIRITUAL ENLIGHTENMENT; ENTERTAINMENT SERVICES, NAMELY, PROVIDING GAMES OF CHANCE VIA THE INTERNET; ENTERTAINMENT SERVICES, NAMELY, PROVIDING NON-DOWNLOADABLE PLAYBACK OF MUSIC VIA GLOBAL COMMUNICATIONS NETWORKS; ENTERTAINMENT SERVICES, NAMELY, PROVIDING ON-LINE COMPUTER GAMES; ENTERTAINMENT SERVICES, NAMELY, PROVIDING ONLINE VIDEO GAMES; FILM AND VIDEO PRODUCTION; FILM AND VIDEO

PRODUCTION CONSULTING SERVICES; MULTIMEDIA ENTERTAINMENT SERVICES IN THE NATURE OF DEVELOPMENT, PRODUCTION AND POST-PRODUCTION SERVICES IN THE FIELDS OF VIDEO AND FILMS; MULTIMEDIA PUBLISHING OF BOOKS, MAGAZINES, JOURNALS, SOFTWARE, GAMES, MUSIC, AND ELECTRONIC PUBLICATIONS; MUSIC SELECTION SERVICES FOR USE IN TELEVISION, FILM, RADIO AND VIDEO GAMES; ORGANIZATION OF GAMES; PROVIDING ONLINE NON-DOWNLOADABLE COMIC BOOKS AND GRAPHIC NOVELS (U.S. CLS. 100, 101 AND 107).

FIRST USE 6-5-2002; IN COMMERCE 2-4-2010.

**CLASS 42—SCIENTIFIC AND COMPUTER SERVICES**

FOR DESIGN AND DEVELOPMENT OF COMPUTER GAME SOFTWARE AND VIRTUAL REALITY SOFTWARE (U.S. CLS. 100 AND 101).

FIRST USE 6-5-2002; IN COMMERCE 2-5-2010.

3,941,842. 21 DROPS LLC, DELRAY BEACH, FL. SN 77-925,187. PUB. 6-22-2010, FILED 2-1-2010.

# 21 DROPS

THE MARK CONSISTS OF STANDARD CHARACTERS WITHOUT CLAIM TO ANY PARTICULAR FONT, STYLE, SIZE, OR COLOR.

**CLASS 3—COSMETICS AND CLEANING PREPARATIONS**

FOR ESSENTIAL OILS FOR USE IN AROMATHERAPY (U.S. CLS. 1, 4, 6, 50, 51 AND 52).

FIRST USE 11-8-2010; IN COMMERCE 11-8-2010.

**CLASS 35—ADVERTISING AND BUSINESS**

FOR RETAIL STORE SERVICES FEATURING ESSENTIAL OILS FOR USE IN AROMATHERAPY (U.S. CLS. 100, 101 AND 102).

FIRST USE 11-8-2010; IN COMMERCE 11-8-2010.

3,941,900. ALLIANCE GLOBAL GROUP II INC., WESTON, FL. SN 77-935,661. PUB. 7-6-2010, FILED 2-15-2010.

# SIBARI

THE MARK CONSISTS OF STANDARD CHARACTERS WITHOUT CLAIM TO ANY PARTICULAR FONT, STYLE, SIZE, OR COLOR.

THE ENGLISH TRANSLATION OF "SIBARI" IN THE MARK IS "SYBARIS".

**CLASS 9—ELECTRICAL AND SCIENTIFIC APPARATUS**

FOR BAGS AND CASES SPECIALLY ADAPTED FOR HOLDING OR CARRYING PORTABLE TELEPHONES AND TELEPHONE EQUIPMENT AND ACCESSORIES; BAGS FOR CAMERAS AND PHOTOGRAPHIC EQUIPMENT; COMPUTER BAGS; LAPTOP CARRYING CASES; MESSENGER BAGS ESPECIALLY ADAPTED FOR HOLDING ELECTRONIC BOOK READERS; MESSENGER BAGS ESPECIALLY ADAPTED FOR HOLDING LAPTOPS; PORTABLE PHOTOGRAPHY EQUIPMENT, NAMELY, REFLECTORS, TRIPODS, LIGHT STANDS AND SUPPORTS AND BAGS SPECIALLY ADAPTED FOR THESE GOODS, LAPTOPS AND PORTABLE MEDIA PLAYERS (U.S. CLS. 21, 23, 26, 36 AND 38).

FIRST USE 9-15-2010; IN COMMERCE 9-15-2010.

**CLASS 13—FIREARMS**

FOR AMMUNITION BAGS; AMMUNITION CASINGS; CARTRIDGE CASES; PISTOL HOLSTERS; SNIPER DRAG BAGS; WEAPON CASES FOR FIREARMS (U.S. CLS. 2 AND 9).

FIRST USE 9-15-2010; IN COMMERCE 9-15-2010.

**CLASS 18—LEATHER GOODS**

FOR ALL PURPOSE SPORT BAGS; ALL-PURPOSE ATHLETIC BAGS; ALL-PURPOSE CARRYING BAGS; BACKPACKS; BACKPACKS, BOOK BAGS, SPORTS BAGS; BAGS AND HOLDALLS FOR SPORTS CLOTHING; BAGS FOR CARRYING BABIES' ACCESSORIES; BARREL BAGS; BEACH BAGS; BELT BAGS; BELT BAGS AND HIP BAGS; BOOK BAGS; CANVAS SHOPPING BAGS; CARRY-ON BAGS; COSMETIC BAGS SOLD EMPTY; DUFFEL BAGS; DUFFLE BAGS; GYM BAGS; HUNTING BAGS; MILITARY DUFFLE BAGS, GARMENT BAGS FOR TRAVEL, TOTE BAGS, SHOULDER BAGS AND BACKPACKS; RUCKSACKS; SHOULDER BAGS; TOTE BAGS (U.S. CLS. 1, 2, 3, 22 AND 41).

FIRST USE 9-15-2010; IN COMMERCE 9-15-2010.

**CLASS 35—ADVERTISING AND BUSINESS**

FOR ADVERTISING, INCLUDING ON-LINE ADVERTISING ON A COMPUTER NETWORK; AUCTION MANAGEMENT SERVICES PROVIDED TO OTHERS OVER AN ON-LINE WEB SITE ACCESSED THROUGH A GLOBAL COMPUTER NETWORK; ON-LINE WHOLESALE AND RETAIL STORE SERVICES FEATURING BAGS, CASES, LUGGAGE, TENTS, AWNING, APPAREL AND OUTDOOR GEAR (U.S. CLS. 100, 101 AND 102).

FIRST USE 8-20-2010; IN COMMERCE 8-20-2010.

**CLASS 9—ELECTRICAL AND SCIENTIFIC APPARATUS**

FOR DOWNLOADABLE VIDEO RECORDINGS FEATURING ENTERTAINMENT IN THE NATURE OF MOTION PICTURES, FILMS AND TELEVISION PROGRAMS IN THE FIELD OF COMEDY, DRAMA, ANIMATED SERIES, AND DOCUMENTARY (U.S. CLS. 21, 23, 26, 36 AND 38).

FIRST USE 3-1-2010; IN COMMERCE 3-1-2010.

**CLASS 38—COMMUNICATION**

FOR VIDEO AND AUDIO BROADCASTING AND TRANSMISSION; TELEVISION BROADCASTING AND TRANSMISSION; CABLE AND SATELLITE TELEVISION BROADCASTING; SUBSCRIPTION TELEVISION BROADCASTING AND TRANSMISSION; VIDEO-ON-DEMAND TRANSMISSION; VIDEO AND AUDIO TRANSMISSION VIA A GLOBAL COMPUTER NETWORK (U.S. CLS. 100, 101 AND 104).

FIRST USE 3-1-2010; IN COMMERCE 3-1-2010.

**CLASS 41—EDUCATION AND ENTERTAINMENT**

FOR ENTERTAINMENT SERVICES IN THE NATURE OF VIDEO AND AUDIO PROGRAMMING, TELEVISION AND MOTION PICTURE PROGRAMMING, TELEVISION AND MOTION PICTURE PROGRAMMING ON A GLOBAL COMPUTER NETWORK, PRODUCTION AND DISTRIBUTION OF TELEVISION AND MOTION PICTURE PROGRAMMING FOR TELEVISION BROADCASTING AND TRANSMISSION VIA A GLOBAL COMPUTER NETWORK (U.S. CLS. 100, 101 AND 107).

FIRST USE 3-1-2010; IN COMMERCE 3-1-2010.

3,941,930. KABUSHIKI KAISHA SQUARE ENIX, TA SQUARE ENIX CO., LTD., TOKYO, JAPAN. SN 77-944,781. PUB. 7-27-2010, FILED 2-25-2010.

**HEROES OF ABYSSEA**

3,941,910. STARZ ENTERTAINMENT, LLC, ENGLEWOOD, CO. SN 77-939,102. PUB. 5-25-2010, FILED 2-18-2010.

**PLAYING FAVORITES**

THE MARK CONSISTS OF STANDARD CHARACTERS WITHOUT CLAIM TO ANY PARTICULAR FONT, STYLE, SIZE, OR COLOR.

THE MARK CONSISTS OF STANDARD CHARACTERS WITHOUT CLAIM TO ANY PARTICULAR FONT, STYLE, SIZE, OR COLOR.

**CLASS 9—ELECTRICAL AND SCIENTIFIC APPARATUS**

FOR COMPUTER GAME SOFTWARE; VIDEO GAME SOFTWARE (U.S. CLS. 21, 23, 26, 36 AND 38).

FIRST USE 12-6-2010; IN COMMERCE 12-6-2010.

**CLASS 41—EDUCATION AND ENTERTAINMENT**

FOR PROVIDING ON-LINE COMPUTER GAMES; PROVIDING ON-LINE VIDEO GAMES (U.S. CLS. 100, 101 AND 107).

FIRST USE 12-6-2010; IN COMMERCE 12-6-2010.

3,941,942. PWP PRODUCTIONS LLC, TENAFLY, NJ. SN 77-946,928. PUB. 7-27-2010, FILED 3-1-2010.

3,941,962. TOTAL ALIGNMENT, INC., DBA ALIGNMENT, INC., DALLAS, TX. SN 77-956,766. PUB. 8-3-2010, FILED 3-11-2010.

## Siggy Flicker

THE MARK CONSISTS OF STANDARD CHARACTERS WITHOUT CLAIM TO ANY PARTICULAR FONT, STYLE, SIZE, OR COLOR.

### CLASS 41—EDUCATION AND ENTERTAINMENT

FOR EDUCATIONAL AND ENTERTAINMENT SERVICES, NAMELY, PROVIDING MOTIVATIONAL SPEAKING SERVICES IN THE FIELD OF RELATIONSHIPS (U.S. CLS. 100, 101 AND 107).

FIRST USE 10-25-2010; IN COMMERCE 10-25-2010.

### CLASS 45—PERSONAL AND LEGAL SERVICES

FOR COMPUTER DATING SERVICES; DATING SERVICES; DATING SERVICES, NAMELY, PROVIDING AN ON-LINE COMPUTER DATABASE FEATURING SINGLE PEOPLE INTERESTED IN MEETING OTHER SINGLE PEOPLE; INTERNET BASED SOCIAL NETWORKING, INTRODUCTION, AND DATING SERVICES; INTERNET-BASED DATING, SOCIAL INTRODUCTION AND SOCIAL NETWORKING SERVICES; MARRIAGE PARTNER INTRODUCTION OR DATING SERVICES; PROVIDING A WEB SITE FEATURING INFORMATION AND CONTENT IN THE FIELDS OF PERSONAL RELATIONSHIPS, DATING AND FASHION; WEB SITE SERVICES FEATURING ON-LINE DATING CLUB (U.S. CLS. 100 AND 101).

FIRST USE 10-25-2010; IN COMMERCE 10-25-2010.

3,941,944. FISOC, INC., AUSTIN, TX. SN 77-947,740. PUB. 7-27-2010, FILED 3-1-2010.

## FISOC

THE MARK CONSISTS OF STANDARD CHARACTERS WITHOUT CLAIM TO ANY PARTICULAR FONT, STYLE, SIZE, OR COLOR.

### CLASS 35—ADVERTISING AND BUSINESS

FOR ARRANGING AND CONDUCTING INCENTIVE REWARD PROGRAMS TO PROMOTE THE SALE OF FINANCIAL SERVICES (U.S. CLS. 100, 101 AND 102).

FIRST USE 0-0-2010; IN COMMERCE 0-0-2010.

### CLASS 42—SCIENTIFIC AND COMPUTER SERVICES

FOR PROVIDING ON-LINE NON-DOWNLOADABLE SOFTWARE FOR PROVIDING FINANCIAL INFORMATION AND FINANCIAL MANAGEMENT (U.S. CLS. 100 AND 101).

FIRST USE 0-0-2010; IN COMMERCE 0-0-2010.

## ASPIRE TO FLY

THE MARK CONSISTS OF STANDARD CHARACTERS WITHOUT CLAIM TO ANY PARTICULAR FONT, STYLE, SIZE, OR COLOR.

### CLASS 35—ADVERTISING AND BUSINESS

FOR BUSINESS CONSULTING SERVICES (U.S. CLS. 100, 101 AND 102).

FIRST USE 1-11-2011; IN COMMERCE 1-11-2011.

### CLASS 41—EDUCATION AND ENTERTAINMENT

FOR EXECUTIVE AND LEADERSHIP COACHING SERVICES; MOTIVATIONAL AND EDUCATIONAL SEMINARS AND WORKSHOPS IN THE FIELD OF LEADERSHIP DEVELOPMENT (U.S. CLS. 100, 101 AND 107).

FIRST USE 1-11-2011; IN COMMERCE 1-11-2011.

3,941,964. DEWI COLLECTION LLC, DBA PICKLED PINK, PALM BEACH, FL. SN 77-956,988. PUB. 11-2-2010, FILED 3-11-2010.



NO CLAIM IS MADE TO THE EXCLUSIVE RIGHT TO USE "GOURMET PICKLES & RELISHES" AND "PALM BEACH, FL (561)932-2382", APART FROM THE MARK AS SHOWN.

THE COLOR(S) PINK, LIGHT PINK, BLACK AND GRAY IS/ARE CLAIMED AS A FEATURE OF THE MARK.

THE MARK CONSISTS OF THE LETTERS "PP" IN PINK, THE WORDING "PICKLED PINK" IN BLACK, THE WORDING "GOURMET PICKLES & RELISHES . PALM BEACH, FL (561) 932-2382" IN GRAY AND A PLANT DESIGN IN BLACK ON A LIGHT PINK BACKGROUND WITH GREY SHADING.

### CLASS 29—MEATS AND PROCESSED FOODS

FOR PICKLES, PICKLED BEETS, PICKLED GREEN BEANS, PICKLED CARROTS, PICKLED ASPARAGUS, PICKLED CRANBERRIES; JAMS AND JELLIES (U.S. CL. 46).

FIRST USE 9-15-2009; IN COMMERCE 9-15-2009.

**CLASS 30—STAPLE FOODS**

FOR RELISH, BEET RELISH, MUSTARD RELISH, GREEN TOMATO CHOW CHOW RELISH, HEIRLOOM TOMATO RELISH, ROASTED CORN RELISH; SAUCES (U.S. CL. 46).

FIRST USE 9-15-2009; IN COMMERCE 9-15-2009.

---

3,941,974. SAVE-A-LOT FOOD STORES, LTD., EARTH CITY, MO. SN 77-959,876. PUB. 6-15-2010, FILED 3-16-2010.

**JADE DRAGON**

THE MARK CONSISTS OF STANDARD CHARACTERS WITHOUT CLAIM TO ANY PARTICULAR FONT, STYLE, SIZE, OR COLOR.

OWNER OF U.S. REG. NO. 2,290,625.

**CLASS 29—MEATS AND PROCESSED FOODS**

FOR FROZEN ENTREES CONSISTING PRIMARILY OF MEAT, FISH, POULTRY OR VEGETABLES (U.S. CL. 46).

FIRST USE 1-1-2010; IN COMMERCE 1-15-2010.

**CLASS 30—STAPLE FOODS**

FOR SAUCES; FROZEN ENTREES CONSISTING PRIMARILY OF PASTA OR RICE (U.S. CL. 46).

FIRST USE 12-1-2010; IN COMMERCE 12-15-2010.

---

3,941,988. PARKMOBILE USA, INC., ATLANTA, GA. SN 77-964,336. PUB. 8-10-2010, FILED 3-21-2010.

**PARK. PHONE. GO.**

THE MARK CONSISTS OF STANDARD CHARACTERS WITHOUT CLAIM TO ANY PARTICULAR FONT, STYLE, SIZE, OR COLOR.

**CLASS 36—INSURANCE AND FINANCIAL**

FOR PAYMENT SERVICES, NAMELY, BILL PAYMENT SERVICES USING ON-LINE SYSTEMS, THE INTERNET, PDAS OR MOBILE PHONES; FINANCIAL TRANSACTIONS SERVICES, NAMELY, PROVIDING SECURE COMMERCIAL TRANSACTIONS AND PAYMENT OPTIONS USING A MOBILE DEVICE AT A POINT OF SALE; FINANCIAL AFFAIRS SERVICES, NAMELY, FINANCIAL CONSULTATION; AND ELECTRONIC FUNDS TRANSFERS (U.S. CLS. 100, 101 AND 102).

FIRST USE 3-31-2010; IN COMMERCE 3-31-2010.

**CLASS 42—SCIENTIFIC AND COMPUTER SERVICES**

FOR APPLICATION SERVICE PROVIDER (ASP) FEATURING SOFTWARE FOR USE IN PROCESSING PARKING TRANSACTIONS; APPLICATION SERVICE PROVIDER (ASP) FEATURING SOFTWARE FOR USE AS AN ELECTRONIC PLATFORM THAT ACCOMMODATES PARKING TRANSACTIONS IN A MOBILE PHONE, PDA, AND WEB-BASED ENVIRONMENT (U.S. CLS. 100 AND 101).

FIRST USE 3-31-2010; IN COMMERCE 3-31-2010.

---

3,941,989. PARKMOBILE USA, INC., ATLANTA, GA. SN 77-964,338. PUB. 8-10-2010, FILED 3-21-2010.

**PARKING MADE SIMPLE**

THE MARK CONSISTS OF STANDARD CHARACTERS WITHOUT CLAIM TO ANY PARTICULAR FONT, STYLE, SIZE, OR COLOR.

NO CLAIM IS MADE TO THE EXCLUSIVE RIGHT TO USE "PARKING", APART FROM THE MARK AS SHOWN.

**CLASS 36—INSURANCE AND FINANCIAL**

FOR PAYMENT SERVICES, NAMELY, BILL PAYMENT SERVICES USING ON-LINE SYSTEMS, THE INTERNET, PDAS OR MOBILE PHONES; FINANCIAL TRANSACTIONS SERVICES, NAMELY, PROVIDING SECURE COMMERCIAL TRANSACTIONS AND PAYMENT OPTIONS USING A MOBILE DEVICE AT A POINT OF SALE; FINANCIAL AFFAIRS SERVICES, NAMELY, FINANCIAL CONSULTATION; AND ELECTRONIC FUNDS TRANSFERS (U.S. CLS. 100, 101 AND 102).

FIRST USE 4-12-2010; IN COMMERCE 4-12-2010.

**CLASS 42—SCIENTIFIC AND COMPUTER SERVICES**

FOR APPLICATION SERVICE PROVIDER (ASP) FEATURING SOFTWARE FOR USE IN PROCESSING PARKING TRANSACTIONS; APPLICATION SERVICE PROVIDER (ASP) FEATURING SOFTWARE FOR USE AS AN ELECTRONIC PLATFORM THAT ACCOMMODATES PARKING TRANSACTIONS IN A MOBILE PHONE, PDA, AND WEB-BASED ENVIRONMENT (U.S. CLS. 100 AND 101).

FIRST USE 4-12-2010; IN COMMERCE 4-12-2010.

---

3,941,990. IS THAT ODD, INC., KIRKLAND, WA. SN 77-964,846. PUB. 8-10-2010, FILED 3-22-2010.

**IS THAT ODD**

THE MARK CONSISTS OF STANDARD CHARACTERS WITHOUT CLAIM TO ANY PARTICULAR FONT, STYLE, SIZE, OR COLOR.

**CLASS 35—ADVERTISING AND BUSINESS**

FOR ADVERTISING SERVICES, NAMELY, ARRANGING FOR THE PROMOTION OF GOODS AND SERVICES TO PARTICIPANTS IN AN ONLINE COMMUNITY FORUM AND SOCIAL NETWORK (U.S. CLS. 100, 101 AND 102).

FIRST USE 12-0-2009; IN COMMERCE 12-0-2009.

**CLASS 38—COMMUNICATION**

FOR PROVIDING ON-LINE CHAT ROOMS AND ELECTRONIC BULLETIN BOARDS FOR TRANSMISSION OF MESSAGES AMONG USERS IN THE FIELD OF GENERAL INTEREST; PROVIDING AN ONLINE COMMUNITY FORUM NAMELY, ON-LINE CHAT ROOMS AND ELECTRONIC BULLETIN BOARDS, FOR USERS TO SHARE INFORMATION, PHOTOS, AUDIO AND VIDEO CONTENT IN THE FIELD OF GENERAL INTEREST, AND TO ENGAGE IN SOCIAL NETWORKING (U.S. CLS. 100, 101 AND 104).

FIRST USE 12-0-2009; IN COMMERCE 12-0-2009.

3,941,991. IS THAT ODD, INC., KIRKLAND, WA. SN 77-964,848. PUB. 8-17-2010, FILED 3-22-2010.

# ODD COINS

THE MARK CONSISTS OF STANDARD CHARACTERS WITHOUT CLAIM TO ANY PARTICULAR FONT, STYLE, SIZE, OR COLOR.

**CLASS 35—ADVERTISING AND BUSINESS**

FOR ADVERTISING SERVICES, NAMELY, ARRANGING FOR THE PROMOTION OF GOODS AND SERVICES TO PARTICIPANTS IN AN ONLINE COMMUNITY FORUM AND SOCIAL NETWORK (U.S. CLS. 100, 101 AND 102).

FIRST USE 9-23-2010; IN COMMERCE 9-23-2010.

**CLASS 38—COMMUNICATION**

FOR PROVIDING ON-LINE CHAT ROOMS AND ELECTRONIC BULLETIN BOARDS FOR TRANSMISSION OF MESSAGES AMONG USERS IN THE FIELD OF GENERAL INTEREST; PROVIDING AN ONLINE COMMUNITY FORUM, NAMELY, ON-LINE CHAT ROOMS AND ELECTRONIC BULLETIN BOARDS, FOR USERS TO SHARE INFORMATION, PHOTOS, AUDIO AND VIDEO CONTENT IN THE FIELD OF GENERAL INTEREST, AND TO ENGAGE IN SOCIAL NETWORKING (U.S. CLS. 100, 101 AND 104).

FIRST USE 9-23-2010; IN COMMERCE 9-23-2010.

3,941,995. MANTLE I.P. HOLDINGS, LTD, PLANO, TX. SN 77-967,176. PUB. 9-7-2010, FILED 3-24-2010.



OWNER OF U.S. REG. NOS. 2,900,042 AND 2,914,722. THE NAME(S), PORTRAIT(S), AND/OR SIGNATURE(S) SHOWN IN THE MARK DOES NOT IDENTIFY A PARTICULAR LIVING INDIVIDUAL.

THE MARK CONSISTS OF THE SIGNATURE OF "MICK-EY MANTLE".

**CLASS 41—EDUCATION AND ENTERTAINMENT**

FOR PROVIDING A WEBSITE FEATURING NON-DOWNLOADABLE MULTIMEDIA MATERIALS, NAMELY, FILM CLIPS, VIDEOS, PHOTOGRAPHS, OTHER MULTIMEDIA MATERIALS, AND INFORMATION IN THE FIELD OF BASEBALL; MUSEUM SERVICES (U.S. CLS. 100, 101 AND 107).

FIRST USE 4-30-2007; IN COMMERCE 4-30-2007.

**CLASS 43—HOTEL AND RESTAURANT SERVICES**

FOR RESTAURANT SERVICES (U.S. CLS. 100 AND 101).

FIRST USE 11-26-2000; IN COMMERCE 11-26-2000.

3,941,997. MEMPHIS BIOWORKS FOUNDATION, MEMPHIS, TN. SN 77-968,623. PUB. 8-17-2010, FILED 3-25-2010.



OWNER OF U.S. REG. NOS. 3,105,876 AND 3,195,606. THE STIPLING IS A FEATURE OF THE MARK AND DOES NOT INDICATE COLOR.

THE MARK CONSISTS OF HONEYCOMB PATTERN WITH THE LETTERS "AG" IN THE TOP CELL AND THE REMAINING INDIVIDUAL LETTERS OF THE LITERAL ELEMENT IN THE OTHER CELLS.

**CLASS 35—ADVERTISING AND BUSINESS**

FOR ADVISORY SERVICES RELATING TO BUSINESS MANAGEMENT AND BUSINESS OPERATIONS; ARRANGING AND CONDUCTING BUSINESS CONFERENCES; ASSOCIATION SERVICES, NAMELY, PROMOTING THE INTERESTS OF AGRICULTURAL BIOLOGISTS; BUSINESS CONSULTATION SERVICES; BUSINESS NETWORKING; CHAMBER OF COMMERCE SERVICES, NAMELY, PROMOTING BUSINESS AND TOURISM IN THE MISSISSIPPI RIVER DELTA REGION; CONSULTING SERVICES IN THE AREA OF SUSTAINABLE BUSINESS SOLUTIONS; ECONOMIC CONSULTING AND INFORMATION FOR THE INDUSTRIAL AND COMMERCIAL SECTORS FOR PLANNING, ORGANIZING, MONITORING AND CARRYING OUT UNIQUE AND COMPLEX PROJECTS IN DIFFERENT SECTORS OF ONE OR SEVERAL COMPANIES; LOBBYING SERVICES, NAMELY, PROMOTING THE INTERESTS OF THE BIOBASED MATERIALS INDUSTRIES IN THE FIELDS OF LEGISLATION AND REGULATION; PROJECT MANAGEMENT SERVICES FOR OTHERS IN THE FIELDS OF THE BIOBASED MATERIALS INDUSTRIES; PROVIDING OFFICE FUNCTIONS (U.S. CLS. 100, 101 AND 102).

FIRST USE 10-0-2010; IN COMMERCE 10-0-2010.

**CLASS 41—EDUCATION AND ENTERTAINMENT**

FOR ARRANGING SEMINARS AND ARRANGING AND CONDUCTING SPECIAL EVENTS; CHARITABLE SERVICES, NAMELY, PROVIDING TRAINING IN THE FIELD OF BIOBASED PRODUCTS AND MATERIALS; CONDUCTING WORKSHOPS AND SEMINARS IN THE FIELD OF BIOBASED PRODUCTS AND MATERIALS; DEVELOPMENT AND DISSEMINATION OF EDUCATIONAL MATERIALS OF OTHERS IN THE FIELD OF BIOBASED PRODUCTS AND MATERIALS; EDUCATIONAL SERVICES, NAMELY, DEVELOPING, ARRANGING, AND CONDUCTING EDUCATIONAL CONFERENCES AND PROGRAMS AND PROVIDING COURSES OF INSTRUCTION IN THE FIELD OF BIOBASED PRODUCTS AND MATERIALS; EDUCATIONAL SERVICES, NAMELY, CONDUCTING INFORMAL ON-LINE PROGRAMS IN THE FIELDS OF BIOBASED PRODUCTS AND MATERIALS, AND PRINTABLE MATERIALS DISTRIBUTED THEREWITH; MEETING AND SEMINAR ARRANGING; ON-LINE ELECTRONIC NEWSLETTERS DELIVERED BY EMAIL IN THE FIELD OF THE BIOBASED MATERIALS INDUSTRIES ; PLANT EXHIBITIONS; PROVIDING SCIENCE EDUCATIONAL MENTORING SERVICES AND PROGRAMS; TEACHING AND TRAINING IN BUSINESS, INDUSTRY AND INFORMATION TECHNOLOGY (U.S. CLS. 100, 101 AND 107).

FIRST USE 10-0-2010; IN COMMERCE 10-0-2010.

3,942,005. NATURIBE BRANDS, LLC, SALINAS, CA. SN 77-980,785. PUB. 2-5-2008, FILED 8-8-2007.

# NATURIBE

THE MARK CONSISTS OF STANDARD CHARACTERS WITHOUT CLAIM TO ANY PARTICULAR FONT, STYLE, SIZE, OR COLOR.

OWNER OF U.S. REG. NO. 2,069,613.

**CLASS 29—MEATS AND PROCESSED FOODS**

FOR FROZEN FRUITS; DRIED FRUITS (U.S. CL. 46).  
FIRST USE 8-2-2010; IN COMMERCE 8-2-2010.

**CLASS 31—NATURAL AGRICULTURAL PRODUCTS**

FOR FRESH FRUITS (U.S. CLS. 1 AND 46).  
FIRST USE 3-1-1922; IN COMMERCE 3-1-1922.

3,942,006. CROWNBEAV, LLC, EUGENE, OR. SN 77-980,806.  
PUB. 6-15-2010, FILED 6-12-2009.

# DIRECTCROWN NATURAL 1

THE MARK CONSISTS OF STANDARD CHARACTERS WITHOUT CLAIM TO ANY PARTICULAR FONT, STYLE, SIZE, OR COLOR.

OWNER OF U.S. REG. NO. 2,377,301.

NO CLAIM IS MADE TO THE EXCLUSIVE RIGHT TO USE "NATURAL AND CROWN", APART FROM THE MARK AS SHOWN.

**CLASS 5—PHARMACEUTICALS**

FOR MATERIALS TO MODEL AND BOND LONG-TERM CROWN SHELLS, NAMELY, DENTAL RESIN (U.S. CLS. 6, 18, 44, 46, 51 AND 52).

FIRST USE 2-9-2011; IN COMMERCE 2-9-2011.

**CLASS 10—MEDICAL APPARATUS**

FOR LONG-TERM DENTAL CROWN SHELLS (U.S. CLS. 26, 39 AND 44).

FIRST USE 2-9-2011; IN COMMERCE 2-9-2011.

3,942,008. SERENIGY GLOBAL, INC., MIAMI, FL. SN 77-981,028. PUB. 5-4-2010, FILED 12-21-2009.

# SERENIGY GLOBAL

THE MARK CONSISTS OF STANDARD CHARACTERS WITHOUT CLAIM TO ANY PARTICULAR FONT, STYLE, SIZE, OR COLOR.

NO CLAIM IS MADE TO THE EXCLUSIVE RIGHT TO USE "GLOBAL", APART FROM THE MARK AS SHOWN.

**CLASS 5—PHARMACEUTICALS**

FOR NUTRACEUTICALS USED AS A FOOD SUPPLEMENT MIXED WITH NON-ORGANIC OR ORGANIC MUSHROOMS (U.S. CLS. 6, 18, 44, 46, 51 AND 52).

FIRST USE 4-7-2010; IN COMMERCE 4-7-2010.

**CLASS 30—STAPLE FOODS**

FOR ORGANIC AND NON-ORGANIC INSTANT COFFEE AND TEA, MIXED WITH ORGANIC AND NON-ORGANIC MUSHROOMS AND MUSHROOM EXTRACTS; POWDERED MIXES USED IN THE PREPARATION OF COFFEE, TEA, AND COCOA-BASED BEVERAGES (U.S. CL. 46).

FIRST USE 4-7-2010; IN COMMERCE 4-7-2010.

3,942,009. UNITED BUSINESS MEDIA LLC, MANHASSET, NY. SN 77-981,082. PUB. 4-27-2010, FILED 10-28-2008.

# CLOUD CONNECT

THE MARK CONSISTS OF STANDARD CHARACTERS WITHOUT CLAIM TO ANY PARTICULAR FONT, STYLE, SIZE, OR COLOR.

NO CLAIM IS MADE TO THE EXCLUSIVE RIGHT TO USE "CLOUD", APART FROM THE MARK AS SHOWN.



**CLASS 9—ELECTRICAL AND SCIENTIFIC APPARATUS**

FOR DOWNLOADABLE ELECTRONIC MAGAZINES IN THE FIELDS OF HIGH TECHNOLOGY, BUSINESS TECHNOLOGY, AND INFORMATION TECHNOLOGY RELATED TO WORKING AWAY FROM THE OFFICE AT REMOTE LOCATIONS, REMOTE DESKTOPS AND SERVER VIRTUALIZATION, COMPUTING, GRID COMPUTING, GRID STORAGE, CLOUD STORAGE, AND ACCESSING PRIVATE FILES FROM REMOTE COMPUTERS AND REMOTE LOCATIONS; DOWNLOADABLE BROCHURES AND REPORTS IN THE FIELDS OF HIGH TECHNOLOGY, BUSINESS TECHNOLOGY, AND INFORMATION TECHNOLOGY (U.S. CLS. 21, 23, 26, 36 AND 38).

FIRST USE 11-0-2008; IN COMMERCE 11-20-2009.

**CLASS 38—COMMUNICATION**

FOR PROVIDING AN ON-LINE FORUM FOR TRANSMISSION OF MESSAGES AMONG COMPUTER USERS IN THE FIELDS OF HIGH TECHNOLOGY, BUSINESS TECHNOLOGY, AND INFORMATION TECHNOLOGY RELATED TO WORKING AWAY FROM THE OFFICE AT REMOTE LOCATIONS, REMOTE DESKTOPS AND SERVER VIRTUALIZATION, COMPUTING, GRID COMPUTING, GRID STORAGE, CLOUD STORAGE, AND ACCESSING PRIVATE FILES FROM REMOTE COMPUTERS AND REMOTE LOCATIONS (U.S. CLS. 100, 101 AND 104).

FIRST USE 11-0-2008; IN COMMERCE 11-20-2009.

3,942,010. RHYTHM HOLDING LIMITED, HONG KONG, HONG KONG. SN 77-981,099. PUB. 8-25-2009, FILED 10-7-2008.

THE SOUND OF CHANGE

THE MARK CONSISTS OF STANDARD CHARACTERS WITHOUT CLAIM TO ANY PARTICULAR FONT, STYLE, SIZE, OR COLOR.

**CLASS 18—LEATHER GOODS**

FOR BACKPACKS, DAY PACKS (U.S. CLS. 1, 2, 3, 22 AND 41).

FIRST USE 8-12-2010; IN COMMERCE 8-12-2010.

**CLASS 25—CLOTHING**

FOR FOOTWEAR; CASUAL FOOTWEAR; SANDALS; HEADGEAR, NAMELY, HATS; CLOTHING, NAMELY, BATHING SUITS AND TRUNKS, BEACHWEAR, SWIMWEAR, BEACH AND BATHING COVERUPS, PANTS, POLO SHIRTS, SHIRTS, SWEAT SHIRTS, T-SHIRTS, TANK TOPS, TOPS, TROUSERS, SHORTS, KNIT SHIRTS, WIND RESISTANT JACKETS (U.S. CLS. 22 AND 39).

FIRST USE 8-12-2010; IN COMMERCE 8-12-2010.

3,942,011. FRANK J. SEPE, INC., VALLEY STREAM, NY. SN 77-981,110. PUB. 9-22-2009, FILED 4-14-2009.



THE COLOR(S) BLACK, RED, AND GRAY IS/ARE CLAIMED AS A FEATURE OF THE MARK.

THE MARK CONSISTS OF FANCIFUL DESIGN OF A RED COLORED CIRCLE ON TOP OF A BLACK COLORED ARC THAT OPENS TOWARDS THE BOTTOM-LEFT SIDE WITH A GRAY COLORED ARC UNDERNEATH AND TO THE RIGHT OF THE BLACK COLORED ARC.

**CLASS 9—ELECTRICAL AND SCIENTIFIC APPARATUS**

FOR DVDS FEATURING PRERECORDED FITNESS WORKOUTS, TELEVISION PROGRAMS, SEMINARS / LECTURES, AND INTERVIEWS IN THE FIELDS OF NUTRITION, HEALTH, FITNESS, EXERCISE, AND WEIGHT LOSS (U.S. CLS. 21, 23, 26, 36 AND 38).

FIRST USE 7-31-2009; IN COMMERCE 7-31-2009.

**CLASS 16—PAPER GOODS AND PRINTED MATTER**

FOR BOOKS ALL IN THE FIELDS OF HEALTH, FITNESS, EXERCISE, AND NUTRITION, BUT NONE OF WHICH RELATE TO HUMAN IMMUNE DISEASES AND CONDITIONS OR THE TREATMENT THEREOF (U.S. CLS. 2, 5, 22, 23, 29, 37, 38 AND 50).

FIRST USE 7-31-2009; IN COMMERCE 7-31-2009.

**CLASS 28—TOYS AND SPORTING GOODS**

FOR FITNESS EQUIPMENT, NAMELY, FITNESS DISCS (U.S. CLS. 22, 23, 38 AND 50).

FIRST USE 7-31-2009; IN COMMERCE 7-31-2009.

3,942,015. E.B. "HUTT" BUSH, JR., BEVERLY HILLS, CA. SN 77-981,166. PUB. 9-15-2009, FILED 5-5-2009.

Being Point

THE MARK CONSISTS OF STANDARD CHARACTERS WITHOUT CLAIM TO ANY PARTICULAR FONT, STYLE, SIZE, OR COLOR.

**CLASS 16—PAPER GOODS AND PRINTED MATTER**

FOR JOURNALS CONCERNING INFORMATION IN THE AREAS OF BUSINESS, FINANCE, SELF-IMPROVEMENT AND PERSONAL LEADERSHIP AND DEVELOPMENT (U.S. CLS. 2, 5, 22, 23, 29, 37, 38 AND 50).

FIRST USE 5-28-2009; IN COMMERCE 5-28-2009.

**CLASS 35—ADVERTISING AND BUSINESS**

FOR BUSINESS LEADERSHIP DEVELOPMENT; BUSINESS MANAGEMENT CONSULTANCY SERVICES; BUSINESS MANAGEMENT CONSULTATION IN THE FIELD OF EXECUTIVE AND LEADERSHIP DEVELOPMENT (U.S. CLS. 100, 101 AND 102).

FIRST USE 11-0-2009; IN COMMERCE 11-0-2009.

---

3,942,017. HUMMINGBIRD HIGHWAY LLC, SYRACUSE, NY. SN 77-981,194. PUB. 6-15-2010, FILED 2-2-2010.

## SCRAP THERAPY

THE MARK CONSISTS OF STANDARD CHARACTERS WITHOUT CLAIM TO ANY PARTICULAR FONT, STYLE, SIZE, OR COLOR.

OWNER OF U.S. REG. NO. 3,613,241.

**CLASS 9—ELECTRICAL AND SCIENTIFIC APPARATUS**

FOR DIGITAL MATERIALS, NAMELY, DOWNLOADABLE PATTERNS FEATURING QUILTS; DOWNLOADABLE ELECTRONIC PUBLICATIONS IN THE NATURE OF ARTICLES, PHOTOGRAPHS AND BROCHURES IN THE FIELD OF QUILTING; ELECTRONIC PUBLICATIONS, NAMELY, BOOKS, ARTICLES MAGAZINES FEATURING QUILTING RECORDED ON COMPUTER MEDIA (U.S. CLS. 21, 23, 26, 36 AND 38).

FIRST USE 10-31-2007; IN COMMERCE 10-31-2007.

**CLASS 41—EDUCATION AND ENTERTAINMENT**

FOR EDUCATIONAL SERVICES, NAMELY, CONDUCTING CLASSES, SEMINARS, WORKSHOPS AND ONE ON ONE TRAINING IN THE FIELD OF QUILTING AND DISTRIBUTION OF TRAINING MATERIAL IN CONNECTION THEREWITH; EDUCATIONAL SERVICES, NAMELY, PROVIDING ON-LINE INSTRUCTIONS AND ASSISTANCE IN THE FIELD OF QUILTING (U.S. CLS. 100, 101 AND 107).

FIRST USE 2-2-2008; IN COMMERCE 2-2-2008.

---

3,942,018. CRYPTOZOIC ENTERTAINMENT, LLC, IRVINE, CA. SN 77-981,209. PUB. 7-27-2010, FILED 3-3-2010.

## CRYPTOZOIC

THE MARK CONSISTS OF STANDARD CHARACTERS WITHOUT CLAIM TO ANY PARTICULAR FONT, STYLE, SIZE, OR COLOR.

**CLASS 16—PAPER GOODS AND PRINTED MATTER**

FOR PAPER GOODS, NAMELY, COMIC BOOKS, TRADING CARDS, COLORING BOOKS, ADHESIVE STICKERS, RUB-ON TRANSFERS, NOTEBOOKS AND STATIONERY-TYPE PORTFOLIOS; POSTERS, GREETING CARDS, CALENDARS; INSTRUCTIONAL LEAFLETS, MANUALS FOR COMPUTER GAMES, ADVERTISEMENT BOARDS OF PAPER OR CARDBOARD, PICTURES, CATALOGUES ON A VARIETY OF SUBJECTS, PHOTOGRAPHS AND PRINTS (U.S. CLS. 2, 5, 22, 23, 29, 37, 38 AND 50).

FIRST USE 4-1-2010; IN COMMERCE 4-1-2010.

**CLASS 28—TOYS AND SPORTING GOODS**

FOR TOYS, NAMELY, TOY ACTION FIGURES AND ACTION FIGURE ACCESSORIES; PLAYING CARDS, TRADING CARD GAMES, BOARD GAMES (U.S. CLS. 22, 23, 38 AND 50).

FIRST USE 4-1-2010; IN COMMERCE 4-1-2010.

---

3,942,019. S. C. JOHNSON & SON, INC., RACINE, WI. SN 77-981,220. PUB. 3-30-2010, FILED 10-8-2009.

## WINDEX

THE MARK CONSISTS OF STANDARD CHARACTERS WITHOUT CLAIM TO ANY PARTICULAR FONT, STYLE, SIZE, OR COLOR.

OWNER OF U.S. REG. NOS. 300,651, 3,254,552, AND OTHERS.

**CLASS 7—MACHINERY**

FOR ALL PURPOSE ELECTRICALLY OPERATED CLEANING BRUSHES (U.S. CLS. 13, 19, 21, 23, 31, 34 AND 35).

FIRST USE 1-27-2010; IN COMMERCE 1-27-2010.

**CLASS 16—PAPER GOODS AND PRINTED MATTER**

FOR DISPOSABLE PADS NOT IMPREGNATED WITH CHEMICALS OR COMPOUNDS FOR HOUSEHOLD USE (U.S. CLS. 2, 5, 22, 23, 29, 37, 38 AND 50).

FIRST USE 1-27-2010; IN COMMERCE 1-27-2010.

**CLASS 21—HOUSEWARES AND GLASS**

FOR BRUSH HEADS FOR ALL PURPOSE ELECTRICALLY OPERATED CLEANING BRUSHES (U.S. CLS. 2, 13, 23, 29, 30, 33, 40 AND 50).

FIRST USE 1-27-2010; IN COMMERCE 1-27-2010.

3,942,023. BLUE MARBLE NETWORK, LLC, SEATTLE, WA.  
SN 77-981,246. PUB. 5-25-2010, FILED 11-9-2009.



THE MARK CONSISTS OF THE LETTERS "B" AND "M" CONTAINED WITHIN A CIRCLE AND THE LETTER "N" TO THE RIGHT OF THE CIRCLE.

#### CLASS 38—COMMUNICATION

FOR MARITIME BROADBAND SATELLITE COMMUNICATION SERVICES, PROVIDED TO COMMERCIAL AND PRIVATE VESSELS, FEATURING BENEFITS INCLUDING IMPROVED COMMUNICATIONS BETWEEN FLEET HEADQUARTERS AND VESSELS (U.S. CLS. 100, 101 AND 104).

FIRST USE 12-30-2010; IN COMMERCE 12-30-2010.

#### CLASS 42—SCIENTIFIC AND COMPUTER SERVICES

FOR TECHNICAL SUPPORT, NAMELY, MONITORING OF MARITIME VESSELS' NETWORK SYSTEMS (U.S. CLS. 100 AND 101).

FIRST USE 12-30-2010; IN COMMERCE 12-30-2010.

#### CLASS 40—MATERIAL TREATMENT

FOR MANUFACTURING SERVICES FOR OTHERS IN THE FIELD OF PARTICLE ENGINEERING INDUSTRIAL TECHNOLOGY EQUIPMENT FOR COMMERCIAL AND INDUSTRIAL USE; CUSTOM MANUFACTURING FEATURING THE SHAPING AND SIZING OF MICRON AND NANO PARTICLES FOR COMMERCIAL AND INDUSTRIAL USE (U.S. CLS. 100, 103 AND 106).

FIRST USE 6-0-2006; IN COMMERCE 6-0-2006.

#### CLASS 42—SCIENTIFIC AND COMPUTER SERVICES

FOR RESEARCH AND DEVELOPMENT SERVICES IN THE FIELD OF PARTICLE ENGINEERING (U.S. CLS. 100 AND 101).

FIRST USE 6-0-2006; IN COMMERCE 6-0-2006.

3,942,026. LG LICENSING, LLC, MIAMI, FL. SN 77-981,269.  
PUB. 3-24-2009, FILED 6-7-2007.

LORENA GARCIA

3,942,024. PRIMET PRECISION MATERIALS, INC., ITHACA, NY. SN 77-981,266. PUB. 7-27-2010, FILED 2-13-2009.

NANOSCISSION

THE MARK CONSISTS OF STANDARD CHARACTERS WITHOUT CLAIM TO ANY PARTICULAR FONT, STYLE, SIZE, OR COLOR.

#### CLASS 1—CHEMICALS

FOR ORGANIC AND INORGANIC MICRON AND NANO PARTICLES IN THE NATURE OF CHEMICAL PREPARATIONS FOR FURTHER PROCESSING AND SYNTHESIS FOR INDUSTRIAL APPLICATIONS (U.S. CLS. 1, 5, 6, 10, 26 AND 46).

FIRST USE 6-0-2006; IN COMMERCE 6-0-2006.

THE MARK CONSISTS OF STANDARD CHARACTERS WITHOUT CLAIM TO ANY PARTICULAR FONT, STYLE, SIZE, OR COLOR.

THE NAME "LORENA GARCIA" IDENTIFIES A LIVING INDIVIDUAL WHOSE CONSENT IS OF RECORD.

#### CLASS 8—HAND TOOLS

FOR CUTLERY AND FLATWARE; HAND TOOLS, NAMELY, MANUALLY OPERATED KITCHEN ACCESSORIES, NAMELY, HAND OPERATED FOOD DICER, HAND OPERATED FOOD SLICER, NON-ELECTRIC FRUIT PEELER, HAND OPERATED MEAT CUBER FOR TENDERIZING MEAT, HAND OPERATED MEAT TENDERIZER IN THE NATURE OF A KITCHEN MALLET, HAND OPERATED SALAD DRYER; BAR TOOL SETS COMPRISED OF ICE TONGS, BOTTLE OPENER, COCKTAIL STRAINER, STIRRER, BAR KNIFE, JIGGER AND ICE BUCKET; CAKE SLICERS (U.S. CLS. 23, 28 AND 44).

FIRST USE 3-1-2010; IN COMMERCE 3-1-2010.

#### CLASS 20—FURNITURE AND ARTICLES NOT OTHERWISE CLASSIFIED

FOR CHAIR PADS, DECORATIVE PILLOWS (U.S. CLS. 2, 13, 22, 25, 32 AND 50).

FIRST USE 3-1-2010; IN COMMERCE 3-1-2010.

**CLASS 21—HOUSEWARES AND GLASS**

FOR DINNERWARE; SERVING WARE FOR SERVING FOOD; COOKWARE, NAMELY, POTS, PANS, COOKING TONGS, STEAMERS, DISH DRAINERS, NON-ELECTRIC PRESSURE COOKERS, NON-ELECTRIC DEEP FRYERS, FRYING PANS, BAKING SHEETS, CAKE BAKING PANS, MUFFIN BAKING PANS, LOAF BAKING PANS, BREAD PANS, KITCHEN LADLES, CAKE SERVERS, SERVING TONGS, SERVING FORKS AND SPOONS; RUBBER SPATULAS; WOODEN COOKING UTENSILS, NAMELY, SPOONS, LADLES, FORKS, SPATULAS, GRATERS, SIEVES, STRAINERS AND TURNERS; MIXING AND SERVING BOWLS; PITCHERS; WINE GLASSES; BATH ACCESSORIES, NAMELY, SOAP HOLDERS, TOOTHPASTE HOLDERS, TOOTHBRUSH HOLDERS, SOAP DISPENSERS, LOTION DISPENSERS, CUPS, TOILET TISSUE HOLDERS, FACIAL TOILET TISSUE HOLDERS; MANUALLY OPERATED KITCHEN ACCESSORIES, NAMELY, NON-ELECTRIC MIXERS FOR HOUSEHOLD PURPOSES, NON-ELECTRIC EGG BEATERS, NON-ELECTRIC FOOD MILLS, HAND OPERATED GARLIC PRESS, HAND OPERATED JAR OPENERS, CANDLE STANDS; MANUALLY OPERATED KITCHEN ACCESSORIES, NAMELY, HAND OPERATED MIXER, HAND OPERATED EGG BEATERS, HAND OPERATED FOOD GRINDER, HAND OPERATED FOOD MILL, HAND OPERATED GARLIC PRESS, HAND OPERATED JAR OPENER; OPERATED PUMPS FOR DISPENSING SOAP AND LOTION (U.S. CLS. 2, 13, 23, 29, 30, 33, 40 AND 50).

FIRST USE 3-1-2010; IN COMMERCE 3-1-2010.

**CLASS 24—FABRICS**

FOR COMFORTERS; UTILITY COMFORTERS; COMFORTER SETS COMPRISED OF FLAT BED SHEET, FITTED BED SHEET, PILLOW CASES AND PILLOW SHAMS, COMFORTER, DECORATIVE PILLOWS AND BED SKIRT; DUVETS; DUVET COVERS; SHAMS; BED SKIRTS; QUILTS; COVERLETS; SLIP COVERS; SHEET SETS COMPRISED OF FLAT BED SHEET, FITTED BED SHEET, PILLOW CASES, BED BLANKETS; TROWS; TOWELS; BATH TOWELS; HAND TOWELS; EMBELLISHED TOWELS; WASH CLOTHS; SHOWER CURTAINS (U.S. CLS. 42 AND 50).

FIRST USE 3-1-2010; IN COMMERCE 3-1-2010.

**CLASS 27—FLOOR COVERINGS**

FOR ACCENT RUGS (U.S. CLS. 19, 20, 37, 42 AND 50).  
FIRST USE 3-1-2010; IN COMMERCE 3-1-2010.

3,942,027. INTERNATIONAL PAYMENTS FRAMEWORK, LLC, HERNDON, VA. SN 77-981,273. PUB. 5-11-2010, FILED 9-30-2008.



NO CLAIM IS MADE TO THE EXCLUSIVE RIGHT TO USE "INTERNATIONAL PAYMENTS FRAMEWORK", APART FROM THE MARK AS SHOWN.

THE MARK CONSISTS OF THE WORD "INTERNATIONAL" ABOVE THE WORDS "PAYMENTS FRAMEWORK" WITH THE LETTERS "IPF" ON THE TOP LEFT WITH A STYLIZED LINE AND BALL DESIGN UNDERNEATH THE LETTERS "IPF".

**CLASS 16—PAPER GOODS AND PRINTED MATTER**

FOR MANUALS RELATING TO THE OPERATION AND PROCESSING OF ELECTRONIC PAYMENTS (U.S. CLS. 2, 5, 22, 23, 29, 37, 38 AND 50).

FIRST USE 2-24-2010; IN COMMERCE 2-24-2010.

**CLASS 35—ADVERTISING AND BUSINESS**

FOR ASSOCIATION SERVICES, NAMELY, PROMOTING THE INTERESTS OF ASSOCIATIONS REPRESENTING FINANCIAL INSTITUTIONS FOR SAFE AND RELIABLE ELECTRONIC PAYMENT (U.S. CLS. 100, 101 AND 102).

FIRST USE 2-24-2010; IN COMMERCE 2-24-2010.

3,942,029. SOLAZYME, INC., SOUTH SAN FRANCISCO, CA. SN 77-981,283. PUB. 10-27-2009, FILED 12-8-2008.

**SOLAZYME HEALTH SCIENCES**

THE MARK CONSISTS OF STANDARD CHARACTERS WITHOUT CLAIM TO ANY PARTICULAR FONT, STYLE, SIZE, OR COLOR.

NO CLAIM IS MADE TO THE EXCLUSIVE RIGHT TO USE "HEALTH SCIENCES", APART FROM THE MARK AS SHOWN.

**CLASS 1—CHEMICALS**

FOR CHEMICALS, NAMELY, MICROBIAL ADDITIVES FOR USE IN THE MANUFACTURE OF COSMETICS, NUTRACEUTICALS, AND A WIDE VARIETY OF GOODS (U.S. CLS. 1, 5, 6, 10, 26 AND 46).

FIRST USE 1-9-2009; IN COMMERCE 1-9-2009.

**CLASS 5—PHARMACEUTICALS**

FOR NUTRACEUTICALS FOR USE AS DIETARY SUPPLEMENTS (U.S. CLS. 6, 18, 44, 46, 51 AND 52).

FIRST USE 1-9-2009; IN COMMERCE 1-9-2009.

**CLASS 42—SCIENTIFIC AND COMPUTER SERVICES**

FOR PRODUCT, LABORATORY, AND INDUSTRIAL RESEARCH AND DEVELOPMENT IN THE FIELD OF BOTANICAL ADDITIVES FOR USE IN THE MANUFACTURE OF COSMETICS, NUTRACEUTICALS, AND A WIDE VARIETY OF GOODS (U.S. CLS. 100 AND 101).

FIRST USE 8-23-2010; IN COMMERCE 8-23-2010.

3,942,031. BLUE MARBLE NETWORK, LLC, SEATTLE, WA. SN 77-981,291. PUB. 5-25-2010, FILED 11-9-2009.

**BLUE MARBLE**

THE MARK CONSISTS OF STANDARD CHARACTERS WITHOUT CLAIM TO ANY PARTICULAR FONT, STYLE, SIZE, OR COLOR.

**CLASS 38—COMMUNICATION**

FOR MARITIME BROADBAND SATELLITE COMMUNICATION SERVICES, PROVIDED TO COMMERCIAL AND PRIVATE VESSELS, FEATURING BENEFITS INCLUDING IMPROVED COMMUNICATIONS BETWEEN FLEET HEADQUARTERS AND VESSELS (U.S. CLS. 100, 101 AND 104).

FIRST USE 12-30-2010; IN COMMERCE 12-30-2010.

**CLASS 42—SCIENTIFIC AND COMPUTER SERVICES**

FOR TECHNICAL SUPPORT, NAMELY, MONITORING OF MARITIME VESSELS' NETWORK SYSTEMS (U.S. CLS. 100 AND 101).

FIRST USE 12-30-2010; IN COMMERCE 12-30-2010.

3,942,048. BAR'S PRODUCTS, INC., HOLLY, MI. SN 77-1981,500. PUB. 4-28-2009, FILED 6-17-2008.



OWNER OF U.S. REG. NOS. 1,872,144, 2,556,976, AND OTHERS.

NO CLAIM IS MADE TO THE EXCLUSIVE RIGHT TO USE "PRODUCTS", APART FROM THE MARK AS SHOWN.

THE MARK CONSISTS OF AN OUTLINED OVAL WITH "BAR'S" IN THE TOP HALF AND "PRODUCTS" IN THE LOWER HALF.

**CLASS 1—CHEMICALS**

FOR PRODUCTS FOR ENGINE REPAIR AND MAINTENANCE, NAMELY, CHEMICAL ADDITIVES FOR INTERNAL COMBUSTION ENGINES, COOLANTS FOR VEHICLE ENGINES, ANTI-LEAK SUBSTANCES FOR INTERNAL COMBUSTION ENGINES, AUTOMOBILE COOLING SYSTEM LEAK SEALANTS, ANTI-KNOCK SUBSTANCES FOR INTERNAL COMBUSTION ENGINES (U.S. CLS. 1, 5, 6, 10, 26 AND 46).

FIRST USE 5-0-2008; IN COMMERCE 5-0-2008.

**CLASS 35—ADVERTISING AND BUSINESS**

FOR PROMOTING SPORTS COMPETITIONS AND/OR EVENTS OF OTHERS, NAMELY, PROMOTING AUTOMOTIVE RACING EVENTS (U.S. CLS. 100, 101 AND 102).

FIRST USE 5-0-2008; IN COMMERCE 5-0-2008.

3,942,056. FLOWER POT PRODUCTIONS, LLC, PASADENA, CA. SN 78-721,745. PUB. 10-2-2007, FILED 9-27-2005.

**FLOWERPOT PRODUCTIONS**

THE MARK CONSISTS OF STANDARD CHARACTERS WITHOUT CLAIM TO ANY PARTICULAR FONT, STYLE, SIZE, OR COLOR.

NO CLAIM IS MADE TO THE EXCLUSIVE RIGHT TO USE "PRODUCTIONS", APART FROM THE MARK AS

SHOWN.

**CLASS 35—ADVERTISING AND BUSINESS**

FOR COUNSELING IN THE FIELD OF PUBLICITY TO ASSIST ARTISTS, ENSEMBLES, MANAGERS OF ARTISTS AND ENSEMBLES, AND TALENT AGENTS IN THE CREATION AND MARKETING OF PERFORMANCES, LIVE ENTERTAINMENT PRODUCTIONS AND TOURING PACKAGES (U.S. CLS. 100, 101 AND 102).

FIRST USE 0-0-2006; IN COMMERCE 0-0-2006.

**CLASS 41—EDUCATION AND ENTERTAINMENT**

FOR ENTERTAINMENT PRODUCTION SERVICES, NAMELY, CONSULTATION REGARDING AND PROVIDING CREATIVE SERVICES RELATING TO THE CREATION AND ORGANIZATION OF PERFORMANCES, LIVE SHOWS AND TOURING PACKAGES FOR ARTISTS, ENSEMBLES, MANAGERS OF ARTISTS AND ENSEMBLES, AND AGENTS (U.S. CLS. 100, 101 AND 107).

FIRST USE 0-0-2006; IN COMMERCE 0-0-2006.

3,942,057. LIFTED RESEARCH GROUP INC., IRVINE, CA. SN 78-724,714. PUB. 10-17-2006, FILED 10-1-2005.

**LIFTED RESEARCH GROUP**

THE MARK CONSISTS OF STANDARD CHARACTERS WITHOUT CLAIM TO ANY PARTICULAR FONT, STYLE, SIZE, OR COLOR.

OWNER OF U.S. REG. NO. 2,513,951.

**CLASS 16—PAPER GOODS AND PRINTED MATTER**

FOR PUBLICATIONS, NAMELY, MAGAZINES RELATING TO FASHION, LIFESTYLE, MUSIC, CULTURE, AND ENTERTAINMENT; PAPER, CARDBOARD AND PRINTED MATERIAL, NAMELY, PHOTOGRAPHS, STATIONERY, POSTERS, PAPER BANNERS, STICKERS, CATALOGS FEATURING APPAREL PRODUCTS, BAGS, ACCESSORIES, JEWELRY, WATCHES, AND OPTICS; AND CARDBOARD FLOOR DISPLAY UNITS FOR MERCHANDISING PRODUCTS (U.S. CLS. 2, 5, 22, 23, 29, 37, 38 AND 50).

FIRST USE 1-9-2010; IN COMMERCE 1-9-2010.

**CLASS 28—TOYS AND SPORTING GOODS**

FOR SKATEBOARDS, SNOWBOARDS, SKIMBOARDS (U.S. CLS. 22, 23, 38 AND 50).

FIRST USE 1-9-2010; IN COMMERCE 1-9-2010.

3,942,058. KIAICO INC., MAHWAH, NJ. SN 78-792,305. PUB. 1-23-2007, FILED 1-16-2006.



THE COLOR GRAY IS NOT INTENDED TO INDICATE COLOR AND IS NOT CLAIMED AS A FEATURE OF THE MARK.

THE MARK CONSISTS OF "I AM A NOYD!" AND A CARTOON CHARACTER IN PROFILE.

#### CLASS 16—PAPER GOODS AND PRINTED MATTER

FOR PUBLICATIONS, NAMELY, GREETING CARDS, POST CARDS, STICKERS, HEAT TRANSFER PAPER, STATIONERY, POSTERS, BOOKS OF ALL TYPES, NAMELY, CHILDREN'S ACTIVITY BOOKS, CHILDREN'S COLORING BOOKS, COMIC BOOKS, COOKBOOKS, TELEPHONE AND ADDRESS BOOKS, ENGAGEMENT BOOKS, DIARIES, CALENDARS, BOOKMARKS, COLOR PRINTS, TRADING CARDS, BOOK COVERS, DECALCOMANIA STICKERS; ENVELOPES, MEMO PADS, NOTEBOOKS, NOTEPADS, RING BINDERS, FOLDERS, STATIONERY OF ALL TYPES, NAMELY, PENS OF ALL TYPES, PENCILS OF ALL TYPES, AND CASES THEREFOR, DRAWING RULERS, STAPLERS, PENCIL SHARPENERS, MARKERS, RUBBER STAMPS, PAPER SIGNS AND BANNERS; PAPER PARTY GOODS, NAMELY, HATS, NAPKINS, PLACE MATS AND DECORATIONS; BAGS OF ALL TYPES, NAMELY, MERCHANDISE BAGS, PAPER AND PLASTIC PARTY BAGS, PAPER PARTY FAVORS OF ALL TYPES, NAMELY, LUNCH BAGS, GIFT WRAPPING PAPER, PAPER HOLIDAY DECORATIONS (U.S. CLS. 2, 5, 22, 23, 29, 37, 38 AND 50).

FIRST USE 3-28-2010; IN COMMERCE 3-28-2010.

#### CLASS 21—HOUSEWARES AND GLASS

FOR PLATES, BOWLS, CUPS, MUGS OF ALL TYPES, NAMELY, PAPER PLATES, BOWLS AND CUPS; THERMOPLASTIC AND MELAMINE PLATES, BOWLS AND CUPS; DECORATIVE BOXES MADE OF PORCELAIN; STATUARY OR MAQUETTES MADE OF PORCELAIN; LUNCH BOXES AND LUNCH PAILS, COMMEMORATIVE PLATES, CAKE MOLDS, CANTEENS, SPORTS BOTTLES SOLD EMPTY, PORCELAIN HOLIDAY ORNAMENTS (U.S. CLS. 2, 13, 23, 29, 30, 33, 40 AND 50).

FIRST USE 3-28-2010; IN COMMERCE 3-28-2010.

#### CLASS 25—CLOTHING

FOR CLOTHING, NAMELY, SHIRTS, T-SHIRTS, SWEATSHIRTS, SWEAT PANTS, SWEAT SUITS, PANTS, SKIRTS, SHORTS, SARONGS, VESTS, BOXER SHORTS, UNDERWEAR, JACKETS, COATS, RAIN WEAR, PULL-OVERS, SWEATERS, JUMPERS, OVERALLS, ROMPERS, INFANT WEAR, SOCKS, SHOES, SLIPPERS, HALLOWEEN AND MASQUERADE COSTUMES, PROMOTIONAL MASCOT CHARACTER COSTUMES, SLEEP WEAR, ROBES, HATS, CAPS, BANDANAS, HEADBANDS, GLOVES, MUFFLERS, SCARVES, SWIM WEAR, BEACH COVER UPS (U.S. CLS. 22 AND 39).

FIRST USE 3-28-2010; IN COMMERCE 3-28-2010.

#### CLASS 28—TOYS AND SPORTING GOODS

FOR TOYS OF ALL TYPES, NAMELY, PLUSH TOYS, PUPPETS, FINGER PUPPETS, STUFFED TOYS, HAND HELD UNITS FOR PLAYING ELECTRONIC GAMES, DOLLS, TOY ACTION FIGURES AND ACCESSORIES, THEREFOR, COLLECTIBLE TOY FIGURES, CASES FOR DOLLS, CASES FOR ACTION FIGURES, CASES FOR PLAY ACCESSORIES, TOY BUILDING BLOCKS, TOY CONSTRUCTION BLOCKS, TOY BANKS, TOY MOBILES, BATH TOYS; PULL TOYS, SWIM TOYS, NAMELY, POOL RINGS AND INFLATABLE SWIM TOYS; SWIM FLOATS FOR RECREATIONAL USE, SAND TOYS, TOY VEHICLES, ACTION SKILL GAMES, BOARD GAMES, CARD GAMES, JIGSAW PUZZLES, MANIPULATIVE PUZZLES, YO-YOS, JUMP ROPES, MASQUERADE COSTUMES, COSTUME MASKS, PARTY FAVORS IN THE NATURE OF SMALL TOYS, BOBBLE HEAD DOLLS, ADULT AND CHILDREN'S PARTY GAMES, PET TOYS, PINATAS, CHRISTMAS TREE ORNAMENTS, MOLDED TOY PLASTIC FIGURINES, SNOW GLOBES, AND PLAYING CARDS (U.S. CLS. 22, 23, 38 AND 50).

FIRST USE 3-28-2010; IN COMMERCE 3-28-2010.

3,942,059. MONTAGE HOTELS & RESORTS, LLC, LAGUNA BEACH, CA. SN 78-794,225. PUB. 6-29-2010, FILED 1-18-2006.

# MONTAGE

THE MARK CONSISTS OF STANDARD CHARACTERS WITHOUT CLAIM TO ANY PARTICULAR FONT, STYLE, SIZE, OR COLOR.

OWNER OF U.S. REG. NO. 2,801,152.

#### CLASS 35—ADVERTISING AND BUSINESS

FOR REAL ESTATE SALES MANAGEMENT (U.S. CLS. 100, 101 AND 102).

FIRST USE 4-2-2010; IN COMMERCE 4-2-2010.

#### CLASS 36—INSURANCE AND FINANCIAL

FOR REAL ESTATE BROKERAGE AND MANAGEMENT SERVICES, NAMELY, MANAGEMENT OF REAL ESTATE, CONDOMINIUMS AND APARTMENTS, LEASING AND RENTAL OF CONDOMINIUMS AND APARTMENTS (U.S. CLS. 100, 101 AND 102).

FIRST USE 4-2-2010; IN COMMERCE 4-2-2010.

#### CLASS 37—CONSTRUCTION AND REPAIR

FOR MAINTENANCE OF REAL ESTATE, NAMELY, CONDOMINIUMS AND APARTMENTS (U.S. CLS. 100, 103 AND 106).

FIRST USE 11-11-2009; IN COMMERCE 11-11-2009.

3,942,066. SILICON IMAGE, INC., SUNNYVALE, CA. SN 78-873,716. PUB. 11-6-2007, FILED 5-1-2006.



OWNER OF U.S. REG. NO. 3,138,461.  
THE MARK CONSISTS OF INCOMPLETE RECTANGLES AND THE WORDING "SILICON IMAGE".  
SEC. 2(F) AS TO "SILICON IMAGE".

#### **CLASS 9—ELECTRICAL AND SCIENTIFIC APPARATUS**

FOR COMPUTER HARDWARE; COMPUTER HARDWARE, NAMELY, MICROPROCESSORS; COMPUTER HARDWARE, NAMELY, VIDEO PROCESSORS AND DIGITAL SIGNAL PROCESSORS; DIGITAL VIDEO INTERFACE TELEVISION TRANSMITTERS AND RECEIVERS; HIGH-DEFINITION TELEVISION TRANSMITTERS AND RECEIVERS; DIGITAL TELEVISION TRANSMITTERS AND RECEIVERS; LIQUID CRYSTAL DISPLAY TELEVISION TRANSMITTERS AND RECEIVERS; DIGITAL TRANSMITTERS, AUDIO-VIDEO RECEIVERS, TRANSCEIVERS, VIDEO GRAPHICS CONTROLLERS; DRIVERS, NAMELY, COMPUTER SOFTWARE USE IN EXTENDING THE OPERATING SYSTEM TO SUPPORT COMPUTER PERIPHERALS, DISK DRIVES, OR TAPE DRIVES; DIGITAL VIDEO GRAPHICS CONTROLLERS, DIGITAL VIDEO POWER CONTROLLERS, ELECTRICAL DIGITAL VIDEO CONTROLLERS; ELECTRICAL LCD PANEL CONTROLLERS; ELECTRICAL DISPLAY CONTROLLERS; ELECTRICAL MONITOR CONTROLLERS; DIGITAL VIDEO PROCESSORS; INTEGRATED CIRCUITS, INTEGRATED CIRCUIT TRANSMITTERS AND INTEGRATED CIRCUIT RECEIVERS; SEMICONDUCTORS; AUDIO VIDEO PROCESSORS; COMPUTER COMPONENTS, NAMELY, PRINTED CIRCUIT BOARDS AND COMPUTER CHIPS; EMBEDDED SYSTEM COMPUTER HARDWARE; CONSUMER ELECTRONICS COMPONENTS, NAMELY, PRINTED CIRCUIT BOARDS, ELECTRICAL CONNECTORS AND SEMICONDUCTORS; COMPUTER STORAGE SYSTEMS AND HOST BUS ADAPTERS; COMPUTER SOFTWARE, NAMELY, SOFTWARE, FIRMWARE, EMBEDDED SOFTWARE, AND UTILITY PROGRAMS FOR MANAGEMENT, TRANSMISSION AND RECEIPT OF DIGITAL DATA; COMPUTER SOFTWARE, FIRMWARE, EMBEDDED SOFTWARE, AND UTILITY PROGRAMS FOR USE AS AN INTERFACE BETWEEN AUDIO/VIDEO SOURCES AND AUDIO/VIDEO MONITORS; COMPUTER SOFTWARE INTERFACE FOR USE IN CONNECTING, CONTROLLING AND NETWORKING A WIDE VARIETY OF COMPUTER AND COMMUNICATIONS HARDWARE, CONSUMER ELECTRONIC DEVICES, COMPONENTS, AND PERIPHERALS (U.S. CLS. 21, 23, 26, 36 AND 38).  
FIRST USE 7-0-2006; IN COMMERCE 7-0-2006.

#### **CLASS 42—SCIENTIFIC AND COMPUTER SERVICES**

FOR COMPUTER HARDWARE CONSULTING SERVICES RELATING TO THE DESIGN AND DEVELOPMENT OF COMPUTER HARDWARE; DESIGN OF COMPUTER MICROPROCESSORS FOR OTHERS; CONSULTING SERVICES IN THE FIELD OF DESIGN AND DEVELOPMENT OF CONSUMER ELECTRONICS, NAMELY, AUDIO/VIDEO RECEIVERS, AUDIO AND VIDEO CASSETTE RECORDERS AND PLAYERS, CABLE, SATELLITE AND TERRESTRIAL DIGITAL SET-TOP BOXES, CABLE BOXES, CAMCORDERS, CAMERAS, CAR BROADCASTING TUNERS, COMPACT DISC PLAYERS AND RECORDERS, COMPUTERS, COMPUTER MONITORS, DIGITAL CAMERAS, DIGI-

TAL TELEVISION TUNERS, DVD PLAYERS AND RECORDERS, DIGITAL VIDEO PLAYERS AND RECORDERS, ELECTRONIC TOUCH PADS, FACSIMILE MACHINES, GLOBAL POSITIONING SYSTEM TRANSMITTERS AND RECEIVERS, HYBRID SET-TOP BOXES, LASER DISC RECORDERS AND PLAYERS, LIQUID CRYSTAL DISPLAY MONITORS, LIQUID CRYSTAL DISPLAY (LCD) PROJECTORS, MP3 RECORDERS AND PLAYERS, MOTION PICTURE CAMERAS, MULTIMEDIA PROJECTORS, OPTICAL SCANNERS, OPTICAL AND MAGNETO-OPTICAL DISC PLAYERS AND RECORDERS FOR AUDIO, VIDEO AND COMPUTER DATA, PAGERS, PERSONAL DIGITAL ASSISTANT, PERSONAL STEREOS, PHOTOCOPYING MACHINES, PHOTOGRAPHIC CAMERAS, PHOTOGRAPHIC PROJECTORS, PORTABLE MEDIA PLAYERS, RADIO PAGERS, RADIOS, SCANNERS, SET-TOP BOXES, SLIDE PROJECTORS, STEREO TUNERS, TELEPHONE ANSWERING MACHINES, TELEVISION SET-TOP BOXES, TELEVISIONS CONTAINING INTEGRATED DIGITAL VIDEO DISC PLAYERS AND RECORDERS, TELEVISIONS, TELEVISION MONITORS, TELEVISION SETS, TELEVISION TUNERS, VIDEO MONITORS, GAMING MACHINES, SET-TOP BOXES CONTAINING INTEGRATED GAMING MACHINES, VIDEO OUTPUT GAME MACHINES FOR USE WITH TELEVISIONS AND EXTERNAL DISPLAY SCREENS OR MONITORS, STAND ALONE VIDEO GAME MACHINES, STAND ALONE VIDEO OUTPUT GAME MACHINES, VIDEO GAME MACHINES FOR USE WITH TELEVISIONS AND EXTERNAL DISPLAY SCREENS OR MONITORS, VIDEO CAMERAS, VIDEO CASSETTE RECORDERS, VIDEO TAPE RECORDERS, VOICE MESSAGING SYSTEMS PRIMARILY COMPRISED OF COMPUTER HARDWARE AND SOFTWARE FOR THE OPERATION OF VOICE MESSAGING FOR RECEIVING, STORING AND PLAYING VOICE MAIL MESSAGES (U.S. CLS. 100 AND 101).  
FIRST USE 7-0-2006; IN COMMERCE 7-0-2006.

3,942,072. SESAME WORKSHOP, NEW YORK, NY. SN 78-960,851. PUB. 10-23-2007, FILED 8-25-2006.

## **ABBY CADABBY**

THE MARK CONSISTS OF STANDARD CHARACTERS WITHOUT CLAIM TO ANY PARTICULAR FONT, STYLE, SIZE, OR COLOR.

#### **CLASS 16—PAPER GOODS AND PRINTED MATTER**

FOR PRINTED MATERIALS, NAMELY, BOOKS FEATURING EDUCATIONAL THEMES AND ENTERTAINMENT DIRECTED TO CHILDREN, PARENTS AND FAMILIES; STORY BOOKS, CHILDREN'S BOOKS, CHILDREN'S ACTIVITY BOOKS; PAPER CAKE DECORATIONS, PAPER CENTERPIECES, PAPER GIFT BAGS, PAPER NAPKINS, PAPER PARTY DECORATIONS, PAPER PARTY FAVORS, PAPER PARTY HATS, PAPER PARTY INVITATIONS, PAPER TABLECLOTHS (U.S. CLS. 2, 5, 22, 23, 29, 37, 38 AND 50).  
FIRST USE 6-0-2007; IN COMMERCE 6-0-2007.

#### **CLASS 25—CLOTHING**

FOR HALLOWEEN COSTUMES (U.S. CLS. 22 AND 39).  
FIRST USE 9-0-2008; IN COMMERCE 9-0-2008.

**CLASS 28—TOYS AND SPORTING GOODS**

FOR TOYS, GAMES AND PLAYTHINGS, NAMELY, PLUSH TOYS, PUPPETS, DOLLS, DOLL ACCESSORIES, PLAY COSTUMES, MASQUERADE GAMES AND COSTUMES (U.S. CLS. 22, 23, 38 AND 50).

FIRST USE 9-0-2008; IN COMMERCE 9-0-2008.

**CLASS 41—EDUCATION AND ENTERTAINMENT**

FOR ONGOING TELEVISION PROGRAM FEATURING EDUCATIONAL THEMES AND ENTERTAINMENT DIRECTED TO CHILDREN, PARENTS AND FAMILIES; PROVIDING ONLINE INFORMATION FEATURING EDUCATIONAL THEMES AND ENTERTAINMENT DIRECTED TO CHILDREN, PARENTS AND FAMILIES (U.S. CLS. 100, 101 AND 107).

FIRST USE 8-15-2006; IN COMMERCE 8-15-2006.

3,942,075. WORLD MARATHON MAJORS LLC, WILMINGTON, DE. SN 78-978,071. PUB. 7-3-2007, FILED 1-23-2006.

**WORLDMARATHONMAJORS**

THE MARK CONSISTS OF STANDARD CHARACTERS WITHOUT CLAIM TO ANY PARTICULAR FONT, STYLE, SIZE, OR COLOR.

**CLASS 25—CLOTHING**

FOR CLOTHING, NAMELY, SHIRTS, SWEATSHIRTS, JACKETS AND HATS (U.S. CLS. 22 AND 39).

FIRST USE 4-17-2006; IN COMMERCE 4-17-2006.

**CLASS 35—ADVERTISING AND BUSINESS**

FOR ASSOCIATION SERVICES, NAMELY, PROMOTING THE INTERESTS OF RUNNERS; PROMOTING ROAD AND MARATHON RACES, PROMOTING THE PUBLIC AWARENESS OF HEALTH, FITNESS, DIET, EXERCISE AND HEALTHY LIFESTYLES (U.S. CLS. 100, 101 AND 102).

FIRST USE 4-17-2006; IN COMMERCE 4-17-2006.

3,942,076. IN YA FACE RECORDS, INC., SAN JOSE, CA. SN 78-979,114. PUB. 11-20-2007, FILED 9-6-2006.



NO CLAIM IS MADE TO THE EXCLUSIVE RIGHT TO USE "RECORDS", APART FROM THE MARK AS SHOWN.

**CLASS 9—ELECTRICAL AND SCIENTIFIC APPARATUS**

FOR MUSICAL SOUND RECORDINGS; DOWNLOADABLE MUSICAL SOUND RECORDINGS (U.S. CLS. 21, 23, 26, 36 AND 38).

FIRST USE 2-10-2011; IN COMMERCE 2-10-2011.

**CLASS 41—EDUCATION AND ENTERTAINMENT**

FOR MUSIC PRODUCTION SERVICES; ENTERTAINMENT, NAMELY, LIVE MUSIC CONCERTS (U.S. CLS. 100, 101 AND 107).

FIRST USE 2-10-2011; IN COMMERCE 2-10-2011.

3,942,077. TRG ACCESSORIES, LLC, ST. LOUIS, MO. SN 78-979,677. PUB. 3-18-2008, FILED 5-4-2006.

**ETA**

THE MARK CONSISTS OF STANDARD CHARACTERS WITHOUT CLAIM TO ANY PARTICULAR FONT, STYLE, SIZE, OR COLOR.

**CLASS 6—METAL GOODS**

FOR TRAVEL ACCESSORIES, NAMELY, METAL LOCKS (U.S. CLS. 2, 12, 13, 14, 23, 25 AND 50).

FIRST USE 2-0-2008; IN COMMERCE 2-0-2008.

**CLASS 9—ELECTRICAL AND SCIENTIFIC APPARATUS**

FOR TRAVEL ACCESSORIES, NAMELY, EAR PLUGS FOR SOUNDPROOFING (U.S. CLS. 21, 23, 26, 36 AND 38).

FIRST USE 2-0-2008; IN COMMERCE 2-0-2008.

**CLASS 18—LEATHER GOODS**

FOR TRAVEL BAGS, NAMELY, TOILETRY BAGS; FABRIC PACKING CUBES AND FOLDERS, NAMELY, TRAVELING CASES FOR HOLDING SMALL CLOTHING ITEMS WHICH CAN THEN BE PACKED IN LARGER PIECES OF LUGGAGE, AND PACKING SLEEVES USED TO HOLD FOLDED GARMENTS; LUGGAGE TAGS AND STRAPS FOR TRAVEL; UMBRELLAS; TRAVEL WALLETS; SECURITY NECK POUCHES; NON-MOTORIZED, COLLAPSIBLE LUGGAGE CARTS (U.S. CLS. 1, 2, 3, 22 AND 41).

FIRST USE 2-0-2008; IN COMMERCE 2-0-2008.

**CLASS 20—FURNITURE AND ARTICLES NOT OTHERWISE CLASSIFIED**

FOR TRAVEL PILLOWS (U.S. CLS. 2, 13, 22, 25, 32 AND 50).

FIRST USE 2-0-2008; IN COMMERCE 2-0-2008.

**CLASS 21—HOUSEWARES AND GLASS**

FOR TRAVEL BOTTLES, SOLD EMPTY (U.S. CLS. 2, 13, 23, 29, 30, 33, 40 AND 50).

FIRST USE 2-0-2008; IN COMMERCE 2-0-2008.



3,942,078. UNLOCKING POTENTIAL, INC., BOSTON, MA.  
SN 85-000,472. PUB. 12-14-2010, FILED 3-29-2010.

## UNLOCKING POTENTIAL

THE MARK CONSISTS OF STANDARD CHARACTERS WITHOUT CLAIM TO ANY PARTICULAR FONT, STYLE, SIZE, OR COLOR.

### CLASS 35—ADVERTISING AND BUSINESS

FOR EDUCATIONAL CONSULTING IN THE FIELD OF KINDERGARTEN THROUGH HIGH SCHOOL ADMINISTRATION REFORM; RECRUITING AND MANAGING EDUCATORS IN THE FIELD OF SCHOOL REFORM (U.S. CLS. 100, 101 AND 102).  
FIRST USE 3-1-2010; IN COMMERCE 3-1-2010.

### CLASS 41—EDUCATION AND ENTERTAINMENT

FOR EDUCATIONAL SERVICES, NAMELY, PROVIDING TRAINING IN THE FIELD OF SCHOOL REFORM; DEVELOPING CURRICULUM FOR EDUCATORS IN THE FIELD OF SCHOOL REFORM; TRAINING EDUCATORS IN THE FIELD OF SCHOOL REFORM (U.S. CLS. 100, 101 AND 107).  
FIRST USE 3-1-2010; IN COMMERCE 3-1-2010.

3,942,079. SWITCH COMMUNICATIONS GROUP LLC, LAS VEGAS, NV. SN 85-001,429. PUB. 11-2-2010, FILED 3-29-2010.

## SWITCHWORKS

THE MARK CONSISTS OF STANDARD CHARACTERS WITHOUT CLAIM TO ANY PARTICULAR FONT, STYLE, SIZE, OR COLOR.

### CLASS 37—CONSTRUCTION AND REPAIR

FOR INSTALLATION OF COMPUTER HARDWARE FOR OTHERS; INSTALLATION OF COMPUTER HARDWARE FOR OTHERS IN A DATACENTER FACILITY; INSTALLATION OF CABLE AND SUPPORT INFRASTRUCTURE HARDWARE ITEMS FOR COMPUTER SYSTEMS (U.S. CLS. 100, 103 AND 106).  
FIRST USE 10-31-2010; IN COMMERCE 10-31-2010.

### CLASS 42—SCIENTIFIC AND COMPUTER SERVICES

FOR DESIGN OF COMPUTER HARDWARE AND SOFTWARE SYSTEMS FOR OTHERS; DESIGN OF COMPUTER HARDWARE AND SOFTWARE SYSTEMS FOR OTHERS IN A DATACENTER FACILITY; INSTALLATION OF COMPUTER SOFTWARE FOR OTHERS; INSTALLATION OF COMPUTER SOFTWARE FOR OTHERS IN A DATACENTER FACILITY; COMPUTER CONSULTATION IN THE FIELD OF PHYSICAL COMPUTER NETWORK INFRASTRUCTURE SYSTEMS; INTEGRATION OF COMPUTER SYSTEMS AND NETWORKS (U.S. CLS. 100 AND 101).  
FIRST USE 10-31-2010; IN COMMERCE 10-31-2010.

3,942,082. MIKRO SYSTEMS, INC., CHARLOTTESVILLE, VA. SN 85-002,689. PUB. 8-24-2010, FILED 3-31-2010.



THE MARK CONSISTS OF A CIRCLE OVERWRITTEN IN CONTRASTING TEXT BY A SINGLE OCCURRENCE OF THE GREEK LETTER "MU" THAT EXTENDS TO AND DISRUPTS THE CIRCUMFERENCE OF THE CIRCLE.

### CLASS 40—MATERIAL TREATMENT

FOR MACHINE SHOP SERVICES, NAMELY, MACHINING PARTS FOR OTHERS; PARTS MOLDING (U.S. CLS. 100, 103 AND 106).  
FIRST USE 2-14-2011; IN COMMERCE 2-14-2011.

### CLASS 42—SCIENTIFIC AND COMPUTER SERVICES

FOR PRODUCT DEVELOPMENT AND ENGINEERING SERVICES FOR OTHERS; TOOL DESIGN (U.S. CLS. 100 AND 101).  
FIRST USE 2-14-2011; IN COMMERCE 2-14-2011.

### CLASS 45—PERSONAL AND LEGAL SERVICES

FOR LICENSING OF INTELLECTUAL PROPERTY (U.S. CLS. 100 AND 101).  
FIRST USE 2-14-2011; IN COMMERCE 2-14-2011.

3,942,092. THE CATALYST GROUP, INC., SPRING HOUSE, PA. SN 85-008,094. PUB. 10-19-2010, FILED 4-7-2010.

## TCG

THE MARK CONSISTS OF STANDARD CHARACTERS WITHOUT CLAIM TO ANY PARTICULAR FONT, STYLE, SIZE, OR COLOR.

### CLASS 35—ADVERTISING AND BUSINESS

FOR BUSINESS CONSULTING AND MARKETING CONSULTING SERVICES TO PETROLEUM, PETROCHEMICAL, SPECIALTY CHEMICAL AND ENVIRONMENTAL INDUSTRY COMPANIES (U.S. CLS. 100, 101 AND 102).  
FIRST USE 3-10-2010; IN COMMERCE 3-10-2010.

**CLASS 42—SCIENTIFIC AND COMPUTER SERVICES**

FOR TECHNICAL CONSULTING SERVICES TO PETROLEUM, PETROCHEMICAL, SPECIALTY CHEMICAL AND ENVIRONMENTAL INDUSTRY COMPANIES IN THE FIELD OF CHEMICAL CATALYSIS (U.S. CLS. 100 AND 101).

FIRST USE 3-10-2010; IN COMMERCE 3-10-2010.

3,942,105. SAGE HOLDINGS GROUP, LTD., ROCHESTER HILLS, MI. SN 85-014,366. PUB. 9-7-2010, FILED 4-15-2010.



THE COLOR(S) BLACK, GREEN, AND YELLOW IS/ARE CLAIMED AS A FEATURE OF THE MARK.

THE MARK CONSISTS OF FIVE BLACK SILHOUETTE FIGURES COMPRISED OF TWO WOMEN, ONE MAN, ONE GIRL, AND A MAN IN A WHEEL CHAIR, WHO ARE WALKING BETWEEN BLACK SILHOUETTES OF TREES; THE BACKGROUND IS COMPRISED OF TREES, SKY, AND MOUNTAINS OR HILLS THAT APPEAR IN SHADES OF GREEN, WITH A YELLOW SETTING SUN AND A LOWER HORIZON THAT APPEARS IN SHADES OF YELLOW.

**CLASS 44—MEDICAL, BEAUTY AND AGRICULTURAL SERVICES**

FOR HEALTH CARE; HEALTH CARE IN THE NATURE OF HEALTH MAINTENANCE ORGANIZATIONS; HEALTH CARE SERVICES, NAMELY, DISEASE MANAGEMENT PROGRAMS; HEALTH CARE SERVICES, NAMELY, WELLNESS PROGRAMS; HOME HEALTH CARE SERVICES; HOME NURSING AID SERVICES; MANAGED HEALTH CARE SERVICES; NURSING CARE; PALLIATIVE CARE SERVICES; PEDIATRIC HEALTH CARE SERVICES; PROVIDING HEALTH CARE INFORMATION BY TELEPHONE; PROVIDING HEALTH CARE INFORMATION BY TELEPHONE AND THE INTERNET; PROVIDING LIMITED IN-HOME PERSONAL MEDICAL SERVICES FOR INDIVIDUALS INCLUDING CHECKING VITAL SIGNS, MED COMPLIANCE AND INDIVIDUAL HYGIENE, SCHEDULING DOCTOR APPOINTMENTS, PICKING UP PRESCRIPTIONS, CHECKING MEDICAL EQUIPMENT AND SUPPLIES, AND PROVIDING ON-LINE INFORMATION RELATED TO THE PERSONAL MEDICAL SERVICES; PROVIDING LIMITED IN-HOME PERSONAL MEDICAL SERVICES FOR INDIVIDUALS INCLUDING CHECKING VITAL SIGNS, MEDICATION COMPLIANCE AND INDIVIDUAL HYGIENE, SCHEDULING DOCTOR APPOINTMENTS, PICKING UP PRESCRIPTIONS, CHECKING MEDICAL EQUIPMENT AND SUPPLIES, AND PROVIDING ON-LINE INFORMATION RELATED TO THESE PERSONAL MEDICAL SERVICES (U.S. CLS. 100 AND 101).

FIRST USE 5-16-2010; IN COMMERCE 9-1-2010.

**CLASS 45—PERSONAL AND LEGAL SERVICES**

FOR IN-HOME SUPPORT SERVICES TO SENIOR PERSONS, NAMELY, GERIATRIC CARE MANAGEMENT SERVICES AND PERSONAL AFFAIRS MANAGEMENT SERVICES IN THE NATURE OF THE COORDINATION OF NECESSARY SERVICES AND CARE FOR OLDER INDIVIDUALS; PERSONAL CARE ASSISTANCE OF ACTIVITIES OF DAILY LIVING, SUCH AS BATHING, GROOMING AND PERSONAL MOBILITY FOR MENTALLY OR PHYSICALLY CHALLENGED PEOPLE; PROVIDING NON-MEDICAL IN-HOME PERSONAL SERVICES FOR INDIVIDUALS INCLUDING CHECKING HOME CONDITION, SUPPLIES AND INDIVIDUAL WELL-BEING, SCHEDULING APPOINTMENTS, RUNNING ERRANDS, MAKING SAFETY CHECKS, AND PROVIDING ON-LINE INFORMATION RELATED TO THE PERSONAL SERVICES; PROVIDING NON-MEDICAL IN-HOME PERSONAL SERVICES FOR INDIVIDUALS INCLUDING CHECKING HOME CONDITION, SUPPLIES AND INDIVIDUAL WELL-BEING, SCHEDULING APPOINTMENTS, RUNNING ERRANDS, MAKING SAFETY CHECKS, AND PROVIDING ON-LINE INFORMATION RELATED TO THESE PERSONAL SERVICES; PROVIDING PATIENT ADVOCATE SERVICES TO HOSPITAL PATIENTS AND PATIENTS IN LONG TERM CARE FACILITIES (U.S. CLS. 100 AND 101).

FIRST USE 5-16-2010; IN COMMERCE 9-1-2010.

3,942,119. GETAUTOBIDS, INC., NEW YORK, NY. SN 85-021,486. PUB. 10-19-2010, FILED 4-23-2010.

**MOJO MOTORS**

THE MARK CONSISTS OF STANDARD CHARACTERS WITHOUT CLAIM TO ANY PARTICULAR FONT, STYLE, SIZE, OR COLOR.

NO CLAIM IS MADE TO THE EXCLUSIVE RIGHT TO USE "MOTORS", APART FROM THE MARK AS SHOWN.

**CLASS 35—ADVERTISING AND BUSINESS**

FOR AUCTION MANAGEMENT SERVICES PROVIDED TO OTHERS OVER AN ON-LINE WEB SITE ACCESSED THROUGH A GLOBAL COMPUTER NETWORK; ON-LINE AUCTION SERVICES; ON-LINE TRADING SERVICES IN WHICH BUYERS POST REQUESTS FOR INFORMATION ABOUT AUTOMOBILES FOR SALE, AND SELLERS RESPOND BY POSTING INFORMATION ABOUT AUTOMOBILES, AUTO DEALERS AND COMPETITIVE BIDS FOR AUTOMOBILES, ALL VIA THE INTERNET; PROVIDING A WEB SITE FOR CONNECTING SELLERS WITH BUYERS; PROVIDING AN ON-LINE DIRECTORY INFORMATION SERVICE FEATURING INFORMATION REGARDING AUTO SALES AND AUTO DEALERS; PROVIDING INFORMATION ABOUT AUTOMOBILES FOR SALE BY MEANS OF THE INTERNET (U.S. CLS. 100, 101 AND 102).

FIRST USE 10-29-2010; IN COMMERCE 10-29-2010.

**CLASS 38—COMMUNICATION**

FOR PROVIDING ON-LINE FORUMS FOR TRANSMISSION OF MESSAGES AMONG COMPUTER AND MOBILE PHONE USERS; PROVIDING ON-LINE FORUMS FOR TRANSMISSION OF MESSAGES AMONG COMPUTER AND MOBILE PHONE USERS CONCERNING AUTO SALES AND AUTO DEALERS (U.S. CLS. 100, 101 AND 104).

FIRST USE 10-29-2010; IN COMMERCE 10-29-2010.

3,942,120. HIGHBANK ADVISORS LLC, PHOENIX, MD. SN 85-021,785. PUB. 9-28-2010, FILED 4-23-2010.

# HighBank

THE MARK CONSISTS OF STANDARD CHARACTERS WITHOUT CLAIM TO ANY PARTICULAR FONT, STYLE, SIZE, OR COLOR.

## CLASS 35—ADVERTISING AND BUSINESS

FOR BUSINESS PLANNING AND BUSINESS ANALYSIS AND BUSINESS STRATEGIC PLANNING SERVICES, FRANCHISING, NAMELY, CONSULTATION AND ASSISTANCE IN BUSINESS MANAGEMENT, ORGANIZATION AND PROMOTION (U.S. CLS. 100, 101 AND 102). FIRST USE 11-15-2010; IN COMMERCE 11-15-2010.

## CLASS 36—INSURANCE AND FINANCIAL

FOR FINANCIAL VALUATIONS, FINANCIAL RESTRUCTURING SERVICES, FINANCIAL ADVISORY AND CONSULTANCY SERVICES, FINANCIAL SERVICES, NAMELY, RAISING DEBT AND EQUITY CAPITAL FOR OTHERS, FINANCIAL AND INVESTMENT ADVISORY SERVICES, NAMELY, MANAGEMENT AND ADVICE IN THE FIELDS OF STOCKS, BONDS, OPTIONS, COMMODITIES, FUTURES AND OTHER SECURITIES, FINANCIAL CONSULTING AND ADVISING IN THE FIELD OF MERGERS AND ACQUISITIONS, PRIVATE EQUITY INVESTMENT SERVICES, VENTURE CAPITAL FUND SERVICES, REAL ESTATE MANAGEMENT, FINANCING AND INVESTMENT SERVICES (U.S. CLS. 100, 101 AND 102). FIRST USE 11-15-2010; IN COMMERCE 11-15-2010.

3,942,121. SWITCH COMMUNICATIONS GROUP LLC, LAS VEGAS, NV. SN 85-022,393. PUB. 11-9-2010, FILED 4-24-2010.

# SWITCHFORCE

THE MARK CONSISTS OF STANDARD CHARACTERS WITHOUT CLAIM TO ANY PARTICULAR FONT, STYLE, SIZE, OR COLOR.

## CLASS 42—SCIENTIFIC AND COMPUTER SERVICES

FOR DESIGN AND DEVELOPMENT OF DATACENTER SECURITY SYSTEMS FOR OTHERS; DESIGN AND DEVELOPMENT OF ELECTRONIC DATA SECURITY SYSTEMS (U.S. CLS. 100 AND 101). FIRST USE 10-31-2010; IN COMMERCE 10-31-2010.

## CLASS 45—PERSONAL AND LEGAL SERVICES

FOR SECURITY GUARD SERVICES; SECURITY SURVEILLANCE SERVICES; GUARD AND NIGHT WATCHMAN SERVICES; EMERGENCY RESPONSE ALARM MONITORING SERVICES, NAMELY, MONITORING ALERT DEVICES BY A REMOTE MONITORING CENTER FOR DISPATCH OF EMERGENCY PUBLIC HEALTH AND SECURITY SERVICES AND NOTIFICATION TO THIRD PARTIES; ALARM RESCUE SERVICES, NAMELY, ALARM RESPONSE AND VERIFICATION SERVICES; PHOTOGRAPHIC SURVEILLANCE SERVICES (U.S. CLS. 100 AND 101).

FIRST USE 10-31-2010; IN COMMERCE 10-31-2010.

3,942,131. THE W.E. LONG CO. - INDEPENDENT BAKERS' COOPERATIVE, CHICAGO, IL. SN 85-024,450. PUB. 11-30-2010, FILED 4-27-2010.

THE **LONG** CO.  
CONSULTANTS TO THE FOOD INDUSTRY SINCE 1900

NO CLAIM IS MADE TO THE EXCLUSIVE RIGHT TO USE "CO." OR "CONSULTANTS TO THE FOOD INDUSTRY SINCE 1900", APART FROM THE MARK AS SHOWN.

THE MARK CONSISTS OF STYLIZED WORDING "THE LONG CO." WITH THREE BLADES OF WHEAT APPEARING WITHIN THE LETTER "O" OF THE WORD "LONG" ALL ABOVE THE WORDING "CONSULTANTS TO THE FOOD INDUSTRY SINCE 1900".

## CLASS 35—ADVERTISING AND BUSINESS

FOR BUSINESS CONSULTING SERVICES IN THE FIELD OF THE BAKING INDUSTRY, NAMELY, REGARDING RECOMMENDATIONS OF BAKERY EQUIPMENT FOR USE IN LARGE SCALE, MULTIPLE CONVEYOR AND BAKING LINE BAKERIES IN ORDER TO MAXIMIZE EFFICIENCY AND PROFITABILITY (U.S. CLS. 100, 101 AND 102).

FIRST USE 9-1-2010; IN COMMERCE 9-1-2010.

## CLASS 41—EDUCATION AND ENTERTAINMENT

FOR CONSULTING SERVICES FOR THE BAKING INDUSTRY RELATED TO THE TRAINING OF EMPLOYEES IN THE USE AND OPERATION OF BAKERY EQUIPMENT FOR USE IN LARGE SCALE, MULTIPLE CONVEYOR AND BAKING LINE BAKERIES (U.S. CLS. 100, 101 AND 107).

FIRST USE 9-1-2010; IN COMMERCE 9-1-2010.

3,942,139. YARBOROUGH JEWELRY, LLC, NEW YORK, NY. SN 85-028,050. PUB. 9-21-2010, FILED 5-1-2010.

# YARBIE

THE MARK CONSISTS OF STANDARD CHARACTERS WITHOUT CLAIM TO ANY PARTICULAR FONT, STYLE, SIZE, OR COLOR.

OWNER OF U.S. REG. NO. 3,614,079.

#### CLASS 14—JEWELRY

FOR JEWELRY (U.S. CLS. 2, 27, 28 AND 50).  
FIRST USE 7-1-2010; IN COMMERCE 7-1-2010.

#### CLASS 35—ADVERTISING AND BUSINESS

FOR RETAIL STORE SERVICES, MAIL ORDER CATALOG SERVICES AND ON-LINE RETAIL STORE SERVICES FEATURING JEWELRY (U.S. CLS. 100, 101 AND 102).

FIRST USE 7-1-2010; IN COMMERCE 7-1-2010.

3,942,143. PHILADELPHIA RIVERBOAT LLC, NORFOLK, VA. SN 85-030,594. PUB. 10-26-2010, FILED 5-5-2010.

### PHILADELPHIA BELLE

THE MARK CONSISTS OF STANDARD CHARACTERS WITHOUT CLAIM TO ANY PARTICULAR FONT, STYLE, SIZE, OR COLOR.

NO CLAIM IS MADE TO THE EXCLUSIVE RIGHT TO USE "PHILADELPHIA", APART FROM THE MARK AS SHOWN.

#### CLASS 39—TRANSPORTATION AND STORAGE

FOR CRUISE SHIP SERVICES; ARRANGING AND CONDUCTING SIGHT-SEEING TOURS FOR OTHERS (U.S. CLS. 100 AND 105).

FIRST USE 8-24-2010; IN COMMERCE 8-24-2010.

#### CLASS 41—EDUCATION AND ENTERTAINMENT

FOR ENTERTAINMENT SERVICES PROVIDED ON A CRUISE SHIP, NAMELY, PROVIDING MUSICAL AND THEATRICAL SHOWS (U.S. CLS. 100, 101 AND 107).

FIRST USE 8-24-2010; IN COMMERCE 8-24-2010.

#### CLASS 43—HOTEL AND RESTAURANT SERVICES

FOR RESTAURANT AND BAR SERVICES PROVIDED ON A CRUISE SHIP (U.S. CLS. 100 AND 101).

FIRST USE 8-24-2010; IN COMMERCE 8-24-2010.

3,942,147. BACON, MONICA RENEE, LOS ANGELES, CA. SN 85-031,767. PUB. 10-19-2010, FILED 5-6-2010.



NO CLAIM IS MADE TO THE EXCLUSIVE RIGHT TO USE "ENTERTAINMENT COMPANY", APART FROM THE MARK AS SHOWN.

THE MARK CONSISTS OF THE WORD "SOVEREIGN" WITH THE LETTER "S" HOUSED IN A CIRCLE DESIGN. THE WORDING "A LIFESTYLE ENTERTAINMENT COMPANY" APPEARS UNDER THE LETTERS "EREIGN" OF THE WORD "SOVEREIGN".

#### CLASS 35—ADVERTISING AND BUSINESS

FOR BUSINESS CONSULTING, BUSINESS MANAGEMENT AND PROVIDING INFORMATION IN THE MUSIC BUSINESS FIELD; BUSINESS ORGANIZATION AND MANAGEMENT CONSULTANCY INCLUDING PERSONNEL MANAGEMENT; MANAGEMENT OF PROFESSIONAL ATHLETES (U.S. CLS. 100, 101 AND 102).

FIRST USE 11-1-2004; IN COMMERCE 11-1-2004.

#### CLASS 41—EDUCATION AND ENTERTAINMENT

FOR CONSULTATION AND ADVICE REGARDING MUSICAL SELECTIONS AND ARRANGEMENTS FOR SOUND RECORDINGS AND LIVE PERFORMANCES; MUSIC PUBLISHING SERVICES (U.S. CLS. 100, 101 AND 107).

FIRST USE 11-1-2005; IN COMMERCE 11-1-2005.

3,942,166. AGENCY.COM LLC, NEW YORK, NY. SN 85-041,725. PUB. 11-30-2010, FILED 5-18-2010.

### SIGNAL TO NOISE

THE MARK CONSISTS OF STANDARD CHARACTERS WITHOUT CLAIM TO ANY PARTICULAR FONT, STYLE, SIZE, OR COLOR.

#### CLASS 35—ADVERTISING AND BUSINESS

FOR ADVERTISING AND MARKETING SERVICES (U.S. CLS. 100, 101 AND 102).

FIRST USE 7-13-2010; IN COMMERCE 7-13-2010.

#### CLASS 42—SCIENTIFIC AND COMPUTER SERVICES

FOR DESIGN OF WEBSITES FOR OTHERS (U.S. CLS. 100 AND 101).

FIRST USE 7-13-2010; IN COMMERCE 7-13-2010.

3,942,172. THE RUNNING COMPANY, LLC, INDIANAPOLIS, IN. SN 85-043,795. PUB. 10-19-2010, FILED 5-20-2010.

### BLUEMILE

THE MARK CONSISTS OF STANDARD CHARACTERS WITHOUT CLAIM TO ANY PARTICULAR FONT, STYLE, SIZE, OR COLOR.

**CLASS 35—ADVERTISING AND BUSINESS**

FOR RETAIL STORE SERVICES FEATURING RUNNING AND WALKING FOOTWEAR, SHOES, APPAREL AND ACCESSORIES (U.S. CLS. 100, 101 AND 102).  
FIRST USE 10-22-2010; IN COMMERCE 10-22-2010.

**CLASS 41—EDUCATION AND ENTERTAINMENT**

FOR CONDUCTING INSTRUCTIONAL PROGRAMS IN PHYSICAL FITNESS IN THE FIELD OF RUNNING AND WALKING (U.S. CLS. 100, 101 AND 107).  
FIRST USE 10-22-2010; IN COMMERCE 10-22-2010.

3,942,194. CLOUD RIDERS LTD., PAPHOS, CYPRUS. SN 85-049,286. PUB. 11-9-2010, FILED 5-27-2010.



NO CLAIM IS MADE TO THE EXCLUSIVE RIGHT TO USE "MAIL", APART FROM THE MARK AS SHOWN.

THE MARK CONSISTS OF THE WORDING "MAIL QUATRO" ON A RECTANGULAR BACKGROUND WITH A SUPERIMPOSED RECTANGULAR BACKGROUND BENEATH THE "QUATRO" PORTION OF THE WORDING "MAIL QUATRO".

THE ENGLISH TRANSLATION OF "QUATRO" IN THE MARK IS FOUR.

**CLASS 9—ELECTRICAL AND SCIENTIFIC APPARATUS**

FOR COMPUTER SOFTWARE THAT PROVIDES WEB-BASED ACCESS TO APPLICATIONS AND SERVICES THROUGH A WEB OPERATING SYSTEM OR PORTAL INTERFACE; DOWNLOADABLE SOFTWARE IN THE NATURE OF A MOBILE APPLICATION FOR EMAIL (U.S. CLS. 21, 23, 26, 36 AND 38).  
FIRST USE 4-22-2010; IN COMMERCE 4-22-2010.

**CLASS 41—EDUCATION AND ENTERTAINMENT**

FOR ON-LINE JOURNALS, NAMELY, BLOGS FEATURING DISCUSSIONS IN THE FIELD OF SOFTWARE APPLICATIONS AND WEBMAIL APPLICATIONS (U.S. CLS. 100, 101 AND 107).  
FIRST USE 4-22-2010; IN COMMERCE 4-22-2010.

3,942,222. WHITEPAGES, INC., SEATTLE, WA. SN 85-054,309. PUB. 11-16-2010, FILED 6-3-2010.

# DEALPOP

THE MARK CONSISTS OF STANDARD CHARACTERS WITHOUT CLAIM TO ANY PARTICULAR FONT, STYLE, SIZE, OR COLOR.

**CLASS 9—ELECTRICAL AND SCIENTIFIC APPARATUS**

FOR VOUCHERS, GIFT CARDS, GIFT CERTIFICATES, AND COUPONS DOWNLOADED FROM A GLOBAL COMPUTER NETWORK (U.S. CLS. 21, 23, 26, 36 AND 38).

FIRST USE 7-14-2010; IN COMMERCE 7-14-2010.

**CLASS 35—ADVERTISING AND BUSINESS**

FOR ADVERTISING, MARKETING AND PROMOTING THE GOODS, SERVICES, ACTIVITIES AND EVENTS OF OTHERS, NAMELY, BY PROVIDING A WEBSITE WITH INFORMATION ON DISCOUNTS, COUPONS, SPECIAL OFFERS, VOUCHERS, PRODUCT REVIEWS, AND LINKS TO RETAIL WEB SITES FOR THE GOODS, SERVICES, ACTIVITIES AND EVENTS OF OTHERS (U.S. CLS. 100, 101 AND 102).

FIRST USE 7-14-2010; IN COMMERCE 7-14-2010.

3,942,227. AERIS THERAPEUTICS, LLC, WOBURN, MA. SN 85-055,131. PUB. 11-9-2010, FILED 6-4-2010.

# AERISEAL

THE MARK CONSISTS OF STANDARD CHARACTERS WITHOUT CLAIM TO ANY PARTICULAR FONT, STYLE, SIZE, OR COLOR.

**CLASS 5—PHARMACEUTICALS**

FOR POLYMER-BASED PREPARATIONS FOR THE TREATMENT OF EMPHYSEMA (U.S. CLS. 6, 18, 44, 46, 51 AND 52).

FIRST USE 11-30-2010; IN COMMERCE 11-30-2010.

**CLASS 10—MEDICAL APPARATUS**

FOR MEDICAL DEVICES, NAMELY, NON-SURGICAL DEVICES IN THE NATURE OF ADMINISTRATION DEVICES FOR DELIVERING POLYMER-BASED PREPARATIONS FOR THE TREATMENT OF EMPHYSEMA (U.S. CLS. 26, 39 AND 44).

FIRST USE 11-30-2010; IN COMMERCE 11-30-2010.

3,942,228. FATHERREE, BENJAMIN THOMAS, NEWPORT, KY. SN 85-055,502. PUB. 11-9-2010, FILED 6-5-2010.



THE COLOR(S) RED, WHITE, AND BLUE IS/ARE CLAIMED AS A FEATURE OF THE MARK.

THE MARK CONSISTS OF A DESIGN OF A QUADRILATERAL, WITH THE RIGHT PORTION BLUE AND THE

LEFT PORTION RED, CONTAINING A WHITE STICK FIGURE HOLDING A WHITE CIRCULAR DESIGN.

3,942,248. WATER-JEL TECHNOLOGIES, LLC, CARLSTADT, NJ. SN 85-064,565. PUB. 11-2-2010, FILED 6-16-2010.

### CLASS 28—TOYS AND SPORTING GOODS

FOR ACTION SKILL GAMES; ACTION TARGET GAMES; ATHLETIC EQUIPMENT, NAMELY, GUARDS FOR HANTIS; ATHLETIC EQUIPMENT, NAMELY, HAND WRAPS; ATHLETIC EQUIPMENT, NAMELY, MOUTH GUARDS; ATHLETIC EQUIPMENT, NAMELY, TRAINING DEVICES TO BE WORN ON THE BODY FOR SUPPORT; BAGS SPECIALLY ADAPTED FOR SPORTS EQUIPMENT; BALLS FOR GAMES; BALLS FOR SPORTS; CASES SPECIALLY ADAPTED FOR SPORTS EQUIPMENT; GAME APPARATUS, NAMELY, BASES, BATS, AND BALLS FOR PLAYING INDOOR AND OUTDOOR GAMES; GAME TABLES; GIFT BASKETS COMPRISED PRIMARILY OF IMITATION TOYS SPORTS PRODUCTS, NAMELY, TOY GAME BALLS AND ACCESSORIES THEREFOR; HANDLE GRIPS FOR SPORTING EQUIPMENT; NON-MEDICATED TOPICALLY APPLIED OINTMENT OR GEL FOR IMPROVING HAND GRIP IN SPORTS ACTIVITIES; PADDLE BALL GAMES; PADDLES FOR USE IN PADDLE BALL GAMES; PADS FOR USE IN HANTIS; SAFETY PADDING FOR USE ON WALLS OF STADIUMS AND FIELD ENCLOSURES TO PREVENT INJURY DURING SPORTS EVENTS; SPORT BALLS; SPORTING GOODS, NAMELY, A SPORTS TRAINING DEVICE TO IMPROVE STRENGTH, TONING, CONDITIONING, BALANCE, AND PROPRIOCEPTION; SPORTING GOODS, NAMELY, CARRIERS SPECIALLY ADAPTED FOR SPORT BALLS; TABLE TENNIS BALLS; TABLE TENNIS PADDLES; TABLE TENNIS RACKETS; TABLE TENNIS TABLES; TABLE-TENNIS BALLS; TABLES FOR TABLE TENNIS; TABLETOP GAMES; TROLLEY BAGS SPECIALLY ADAPTED FOR SPORTS EQUIPMENT; VOLLEYBALL GAME PLAYING EQUIPMENT (U.S. CLS. 22, 23, 38 AND 50).

FIRST USE 5-5-2005; IN COMMERCE 5-20-2010.

### CLASS 35—ADVERTISING AND BUSINESS

FOR ADMINISTRATION OF COMMUNITY RECREATIONAL SPORTS LEAGUES; ADVERTISING, INCLUDING PROMOTION OF PRODUCTS AND SERVICES OF THIRD PARTIES THROUGH SPONSORING ARRANGEMENTS AND LICENCE AGREEMENTS RELATING TO INTERNATIONAL SPORTS EVENTS; ADVERTISING, MARKETING AND PROMOTIONAL SERVICES FOR LIGHT AND HEAVY EQUIPMENT DEALERSHIPS; COORDINATION OF RECREATIONAL SPORTING OPPORTUNITIES FOR INDIVIDUALS WHO WISH TO PARTICIPATE IN TEAM LEAGUE SPORTS; MAINTAINING A REGISTRY OF SPORTS MEMORABILIA AND WORKS OF ART; PROMOTING SPORTS COMPETITIONS AND/OR EVENTS OF OTHERS; PROMOTING THE GOODS AND SERVICES OF OTHERS BY ARRANGING FOR SPONSORS TO AFFILIATE THEIR GOODS AND SERVICES WITH AN AWARDS PROGRAM, A SPORTS COMPETITION AND SPORTING ACTIVITIES; PROMOTING THE GOODS AND SERVICES OF OTHERS BY ARRANGING FOR SPONSORS TO AFFILIATE THEIR GOODS AND SERVICES WITH HANTIS; PROMOTING THE INTERESTS OF PEOPLE INVOLVED AND CONCERNED WITH YOUTH SPORTS; PROVIDING A WEB SITE THAT PROVIDES SPORTS LEAGUE MANAGEMENT; PROVIDING AND RENTAL OF EXHIBITION STANDS AND BOOTHS INCLUDING RESPECTIVE EQUIPMENT; RETAIL SPORTING GOODS STORES; SPORTS RECRUITING SERVICES FOR HIGH SCHOOL ATHLETES; TALENT RECRUITING SERVICES IN THE FIELD OF HANTIS (U.S. CLS. 100, 101 AND 102).

FIRST USE 5-5-2005; IN COMMERCE 5-20-2010.

## RADIADERM SYSTEM

THE MARK CONSISTS OF STANDARD CHARACTERS WITHOUT CLAIM TO ANY PARTICULAR FONT, STYLE, SIZE, OR COLOR.

NO CLAIM IS MADE TO THE EXCLUSIVE RIGHT TO USE "SYSTEM", APART FROM THE MARK AS SHOWN.

### CLASS 3—COSMETICS AND CLEANING PREPARATIONS

FOR NON-MEDICATED SKIN CREAMS AND LOTIONS, NON-MEDICATED SKIN CARE PREPARATIONS (U.S. CLS. 1, 4, 6, 50, 51 AND 52).

FIRST USE 1-24-2011; IN COMMERCE 1-24-2011.

### CLASS 5—PHARMACEUTICALS

FOR PHARMACEUTICAL PREPARATIONS FOR THE TREATMENT OF BURNS, CUTS, SCRAPES AND SKIN ABRASIONS; TOPICAL ANALGESICS; PHARMACEUTICAL PREPARATION, NAMELY, BURN DRESSINGS, LOTIONS, CREAMS, AND OINTMENTS FOR THE TREATMENT OF BURNS, SUNBURN AND SKIN IRRITATIONS (U.S. CLS. 6, 18, 44, 46, 51 AND 52).

FIRST USE 1-24-2011; IN COMMERCE 1-24-2011.

3,942,249. REAL WEALTH RADIO, LLC, KEWASKUM, WI. SN 85-064,688. PUB. 11-16-2010, FILED 6-16-2010.

## CLIENT CAST

THE MARK CONSISTS OF STANDARD CHARACTERS WITHOUT CLAIM TO ANY PARTICULAR FONT, STYLE, SIZE, OR COLOR.

### CLASS 9—ELECTRICAL AND SCIENTIFIC APPARATUS

FOR DOWNLOADABLE PODCASTS IN THE FIELD OF INSURANCE AND NON-SECURITIES RELATED TOPICS FOR THE FINANCIAL PROFESSIONAL; DOWNLOADABLE PODCASTS IN THE FIELD OF SECURITIES RELATED TOPICS FOR THE FINANCIAL PROFESSIONAL (U.S. CLS. 21, 23, 26, 36 AND 38).

FIRST USE 6-16-2010; IN COMMERCE 6-16-2010.

### CLASS 36—INSURANCE AND FINANCIAL

FOR PROVIDING A WEB PAGE FEATURING INFORMATION RELATED TO INSURANCE AND NON-SECURITIES RELATED TOPICS FOR THE FINANCIAL PROFESSIONAL; PROVIDING A WEB PAGE FEATURING INFORMATION RELATED TO SECURITIES RELATED TOPICS FOR THE FINANCIAL PROFESSIONAL (U.S. CLS. 100, 101 AND 102).

FIRST USE 6-16-2010; IN COMMERCE 6-16-2010.

3,942,267. YOGABERRY CORPORATION, JACKSONVILLE, FL. SN 85-070,642. PUB. 11-16-2010, FILED 6-24-2010.



NO CLAIM IS MADE TO THE EXCLUSIVE RIGHT TO USE "FROZEN YOGURT", APART FROM THE MARK AS SHOWN.

THE MARK CONSISTS OF THE WORDS "YOBE" AND "FROZEN YOGURT" IN STACKED STYLIZED LETTERS WITH THE "O" IN "YOBE" CONTAINING A STYLIZED DESIGN OF A STRAWBERRY AND THE "B" IN "YOBE" CONTAINING A STYLIZED DESIGN OF A BLUEBERRY.

#### CLASS 30—STAPLE FOODS

FOR FROZEN YOGURT (U.S. CL. 46).  
FIRST USE 10-1-2010; IN COMMERCE 10-1-2010.

#### CLASS 43—HOTEL AND RESTAURANT SERVICES

FOR FROZEN YOGURT SHOP SERVICES IN THE NATURE OF A RESTAURANT (U.S. CLS. 100 AND 101).  
FIRST USE 10-1-2010; IN COMMERCE 10-1-2010.

3,942,270. EAST COAST GIRLS LTD., SARATOGA SPRINGS, NY. SN 85-071,339. PUB. 11-23-2010, FILED 6-25-2010.

# LIFEBOARD

THE MARK CONSISTS OF STANDARD CHARACTERS WITHOUT CLAIM TO ANY PARTICULAR FONT, STYLE, SIZE, OR COLOR.

#### CLASS 16—PAPER GOODS AND PRINTED MATTER

FOR PACKAGED KITS SOLD AS A UNIT CONSISTING OF MOTIVATIONAL MATERIALS, NAMELY, A HANGABLE MEMORANDUM BOARD, INSTRUCTIONAL AND MOTIVATIONAL BOOK, A JOURNAL, STICKERS, AND STORAGE ENVELOPES (U.S. CLS. 2, 5, 22, 23, 29, 37, 38 AND 50).  
FIRST USE 11-17-2010; IN COMMERCE 11-17-2010.

#### CLASS 35—ADVERTISING AND BUSINESS

FOR ON-LINE RETAIL STORE SERVICES FEATURING MOTIVATIONAL THEMED MERCHANDISE IN THE NATURE OF MOTIVATIONAL KITS COMPRISING A HANGABLE MEMORANDUM BOARD, INSTRUCTIONAL AND MOTIVATIONAL BOOK, A JOURNAL, STICKERS, AND STORAGE ENVELOPES; AND ALSO FEATURING MOTIVATIONAL THEMED MERCHANDISE IN THE NATURE OF PRINTED AND PRERECORDED MATERIALS, OFFICE REQUISITES, CLOTHING, MOUSE PADS AND DESKTOP COMPUTER ACCESSORIES, POSTERS, CALENDARS, JOURNALS AND DOWNLOADABLE CELL PHONE APPLICATIONS SOFTWARE, AS WELL AS CANDLES, AROMATHERAPY PRODUCTS, GREETING CARDS, AND SOAPS (U.S. CLS. 100, 101 AND 102).

FIRST USE 11-17-2010; IN COMMERCE 11-17-2010.

3,942,279. BUZZ MONKEY SOFTWARE, LLC, EUGENE, OR. SN 85-073,294. PUB. 11-30-2010, FILED 6-28-2010.

# BLOCK ROGUE

THE MARK CONSISTS OF STANDARD CHARACTERS WITHOUT CLAIM TO ANY PARTICULAR FONT, STYLE, SIZE, OR COLOR.

#### CLASS 9—ELECTRICAL AND SCIENTIFIC APPARATUS

FOR INTERACTIVE GAME SOFTWARE; COMPUTER GAME SOFTWARE; VIDEO GAME PROGRAMS AND CARTRIDGES; ELECTRONIC GAME PROGRAMS; GAME SOFTWARE FOR USE ON ANY COMPUTERIZED PLATFORM, INCLUDING GAME CONSOLES, TELEVISIONS, HAND-HELD ELECTRONIC DEVICES, ELECTRONIC ENTERTAINMENT DEVICES, TELECOMMUNICATIONS DEVICES, MOBILE PHONES, ELECTRONIC COMMUNICATION DEVICES OR PERSONAL DIGITAL ASSISTANT DEVICES; DOWNLOADABLE INTERACTIVE COMPUTER, VIDEO AND ELECTRONIC GAME PROGRAMS (U.S. CLS. 21, 23, 26, 36 AND 38).

FIRST USE 6-19-2009; IN COMMERCE 1-4-2011.

#### CLASS 41—EDUCATION AND ENTERTAINMENT

FOR ENTERTAINMENT SERVICES, NAMELY, PROVIDING ON-LINE INTERACTIVE, COMPUTER, VIDEO OR ELECTRONIC GAMES; PROVIDING NON-DOWNLOADABLE INTERACTIVE, COMPUTER, VIDEO OR ELECTRONIC GAMES THROUGH COMPUTER NETWORKS OR TELEVISION OR OTHER TELECOMMUNICATIONS NETWORKS; PROVIDING WEBSITES FEATURING CONTENT AND INFORMATION IN THE FIELD OF GAMES, INTERACTIVE GAME CONTENT, COMPUTER GAME CONTENT OR ELECTRONIC GAME CONTENT; PROVIDING TEMPORARY USE OF NON-DOWNLOADABLE INTERACTIVE GAMES, COMPUTER GAMES, VIDEO GAMES OR ELECTRONIC GAMES (U.S. CLS. 100, 101 AND 107).

FIRST USE 6-19-2009; IN COMMERCE 1-4-2011.

3,942,286. RUBYSNAP, LLC, SALT LAKE CITY, UT. SN 85-075,078. PUB. 11-16-2010, FILED 6-30-2010.

3,942,299. NATIONAL CENTER FOR PREVENTION AND RESEARCH SOLUTIONS, INC., DAYTONA BEACH, FL. SN 85-081,007. PUB. 12-14-2010, FILED 7-9-2010.

## RUBYSNAP

THE MARK CONSISTS OF STANDARD CHARACTERS WITHOUT CLAIM TO ANY PARTICULAR FONT, STYLE, SIZE, OR COLOR.

### CLASS 30—STAPLE FOODS

FOR BAKERY GOODS; COOKIE DOUGH; COOKIES; FROZEN COOKIE DOUGH (U.S. CL. 46).  
FIRST USE 11-15-2010; IN COMMERCE 12-1-2010.

### CLASS 35—ADVERTISING AND BUSINESS

FOR RETAIL STORE SERVICES FEATURING FROZEN COOKIE DOUGH, BAKED COOKIES, CHOCOLATES, SPECIALTY BAKED GOODS AND GIFTS; ONLINE RETAIL STORE SERVICES FEATURING FROZEN COOKIE DOUGH, BAKED COOKIES, CHOCOLATES AND GIFTS (U.S. CLS. 100, 101 AND 102).  
FIRST USE 11-15-2010; IN COMMERCE 12-1-2010.

---

3,942,294. FIDESSA GROUP, PLC, WOKING, SURREY, UNITED KINGDOM. SN 85-080,307. PUB. 11-16-2010, FILED 7-8-2010.

## OPPORTUNITY CROSSING

THE MARK CONSISTS OF STANDARD CHARACTERS WITHOUT CLAIM TO ANY PARTICULAR FONT, STYLE, SIZE, OR COLOR.

### CLASS 9—ELECTRICAL AND SCIENTIFIC APPARATUS

FOR COMPUTER SOFTWARE FOR MINING SECURITIES TRADING DATA AND CREATING ALERTS IN THE FIELD OF SECURITIES TRADING (U.S. CLS. 21, 23, 26, 36 AND 38).  
FIRST USE 6-30-2010; IN COMMERCE 6-30-2010.

### CLASS 42—SCIENTIFIC AND COMPUTER SERVICES

FOR SOFTWARE AS A SERVICE (SAAS) SERVICES FEATURING SOFTWARE IN THE FIELD OF SECURITIES TRADING FOR MINING SECURITIES TRADING DATA AND CREATING ALERTS IN THE FIELD OF SECURITIES TRADING (U.S. CLS. 100 AND 101).  
FIRST USE 6-30-2010; IN COMMERCE 6-30-2010.

## Fueling a Drug Free Future

THE MARK CONSISTS OF STANDARD CHARACTERS WITHOUT CLAIM TO ANY PARTICULAR FONT, STYLE, SIZE, OR COLOR.

NO CLAIM IS MADE TO THE EXCLUSIVE RIGHT TO USE "DRUG FREE", APART FROM THE MARK AS SHOWN.

### CLASS 35—ADVERTISING AND BUSINESS

FOR PROMOTING PUBLIC AWARENESS OF SUBSTANCE ABUSE PREVENTION (U.S. CLS. 100, 101 AND 102).  
FIRST USE 8-21-2010; IN COMMERCE 8-21-2010.

### CLASS 41—EDUCATION AND ENTERTAINMENT

FOR EDUCATION SERVICES, NAMELY, PROVIDING COURSES IN THE FIELD OF SUBSTANCE ABUSE PREVENTION AND DISTRIBUTING EDUCATIONAL MATERIAL IN CONNECTION THEREWITH (U.S. CLS. 100, 101 AND 107).  
FIRST USE 11-19-2010; IN COMMERCE 11-19-2010.

---

3,942,301. DOMINANT BRANDS LLC, BAYSIDE, NY. SN 85-082,795. PUB. 11-2-2010, FILED 7-12-2010.



THE MARK CONSISTS OF A STYLIZED SHIP DESIGN ENCLOSED IN A SOLID CIRCLE WITH TRANSPARENT HORIZONTAL STRIPES.



**CLASS 35—ADVERTISING AND BUSINESS**

FOR COMMERCIAL BUSINESS MANAGEMENT; BUSINESS ADMINISTRATION CONSULTANCY; BUSINESS ORGANIZATION AND MANAGEMENT CONSULTING; BUSINESS INTERMEDIARY SERVICES AND ADVISORY SERVICES IN THE FIELD OF SELLING PRODUCTS AND RENDERING SERVICES; FINANCIAL MANAGEMENT; ACCOUNTING FOR THIRD PARTIES; ECONOMIC FORECASTING AND ANALYSIS; DATA MANAGEMENT SERVICES FOR BUSINESSES, NAMELY, COLLECTION, PREPARATION, COMPOSITION, PROCESSING, ACQUISITION AND PROVISION OF BUSINESS INFORMATION, DATA, STATISTICS, AND INDICES; PROVIDING STATISTICAL INFORMATION FOR BUSINESS PURPOSES; COMPILATION AND PROVISION OF TRADE AND BUSINESS PRICE AND STATISTICAL INFORMATION; PERSONNEL MANAGEMENT; HUMAN CAPITAL MANAGEMENT OUTSOURCING; ORGANIZING AND CONDUCTING TRADE FAIRS AND EXHIBITIONS FOR ECONOMIC AND ADVERTISING PURPOSES; ARRANGING AND CONDUCTING AUCTION SALES (U.S. CLS. 100, 101 AND 102).

FIRST USE 1-15-2011; IN COMMERCE 1-15-2011.

**CLASS 36—INSURANCE AND FINANCIAL**

FOR INVESTMENT BANKING SERVICES; FINANCIAL ADVISORY SERVICES; INVESTMENT ADVISORY SERVICES IN THE FIELD OF SECURITIES; FINANCIAL INVESTMENT BROKERAGE SERVICES IN THE FIELD OF SECURITIES (U.S. CLS. 100, 101 AND 102).

FIRST USE 1-15-2011; IN COMMERCE 1-15-2011.

\* \* \* \* \*

## SECTION 2.— INTERNATIONAL CLASSIFICATION

The short titles associated below with the international class numbers are terms designed merely for quick identification and are not an official part of the international classification. The full names of international classes are given in section 6.1 of the trademark rules of practice.

The designation "U.S. Cl." appearing in this section refers to the U.S. class in effect prior to Sep. 1, 1973 rather than the international class which applies to applications filed on or after that date. For adoption of international classification see notice in the OFFICIAL GAZETTE of Jun. 26, 1973 (911 O.G. TM 210).

### Application in one class

#### CLASS 1—CHEMICALS

3,941,194. CLABBER GIRL CORPORATION, TERRE HAUTE, IN. SN 77-648,264. PUB. 11-3-2009, FILED 1-13-2009.

#### CLASS 1—(Continued).

3,941,560. MULTI-CHEM GROUP, LLC, SAN ANGELO, TX. SN 77-872,261. PUB. 4-20-2010, FILED 11-13-2009.

# INNOVAYIELD

THE MARK CONSISTS OF STANDARD CHARACTERS WITHOUT CLAIM TO ANY PARTICULAR FONT, STYLE, SIZE, OR COLOR.

FOR ENCAPSULATED DOUGH IMPROVER COMPRISED OF THICKENING AND PRESERVING ADDITIVES FOR NON-NUTRITIONAL PURPOSES, NAMELY, GUAR GUM AND FUMARIC ACID (U.S. CLS. 1, 5, 6, 10, 26 AND 46).

FIRST USE 4-30-2009; IN COMMERCE 4-30-2009.

# ACROCLEAR

THE MARK CONSISTS OF STANDARD CHARACTERS WITHOUT CLAIM TO ANY PARTICULAR FONT, STYLE, SIZE, OR COLOR.

FOR INDUSTRIAL CHEMICALS USED IN OIL AND GAS WELLS AND OIL AND GAS PRODUCTION, NAMELY, INDUSTRIAL CHEMICALS USEFUL AS A SULFIDE SCAVENGER AND CORROSION CONTROL AGENT (U.S. CLS. 1, 5, 6, 10, 26 AND 46).

FIRST USE 8-26-2009; IN COMMERCE 8-26-2009.

3,941,260. ALKEMISTS PHARMACEUTICALS, COSTA MESA, CA. SN 77-722,238. PUB. 11-10-2009, FILED 4-24-2009.

# Composite Reference Botanical

THE MARK CONSISTS OF STANDARD CHARACTERS WITHOUT CLAIM TO ANY PARTICULAR FONT, STYLE, SIZE, OR COLOR.

NO CLAIM IS MADE TO THE EXCLUSIVE RIGHT TO USE "COMPOSITE" AND "BOTANICAL", APART FROM THE MARK AS SHOWN.

FOR BOTANICAL EXTRACTS FOR USE IN MAKING COSMETICS; COMPOSITE CARBON EPOXY RESINS; FOOD PRESERVATIVE COMPOSITIONS; FOOD PRESERVATIVE COMPOSITIONS, NAMELY, OIL FOR THE PRESERVATION OF FOOD; FUNCTIONALIZED SILICONES FOR USE IN THE MANUFACTURE OF PERSONAL CARE AND COSMETIC COMPOSITIONS (U.S. CLS. 1, 5, 6, 10, 26 AND 46).

FIRST USE 6-1-2010; IN COMMERCE 6-1-2010.

3,941,582. WILBUR-ELLIS COMPANY, SAN FRANCISCO, CA. SN 77-878,664. PUB. 4-13-2010, FILED 11-23-2009.

# DIFFUSION

THE MARK CONSISTS OF STANDARD CHARACTERS WITHOUT CLAIM TO ANY PARTICULAR FONT, STYLE, SIZE, OR COLOR.

OWNER OF U.S. REG. NO. 3,033,072.

FOR CHEMICAL PRODUCTS FOR USE IN AGRICULTURE, NAMELY, CHEMICAL SUSPENSIONS FOR APPLICATION TO TREES, PLANTS, AND PRODUCE TO PREVENT SUNBURN (U.S. CLS. 1, 5, 6, 10, 26 AND 46).

FIRST USE 5-10-2010; IN COMMERCE 5-10-2010.

**CLASS 1—(Continued).**

3,941,600. UVIEW ULTRAVIOLET SYSTEMS INC., MISSISSAUGA, ONTARIO, CANADA. SN 77-882,010. PUB. 5-11-2010, FILED 11-30-2009.

# TERRADIESEL

THE MARK CONSISTS OF STANDARD CHARACTERS WITHOUT CLAIM TO ANY PARTICULAR FONT, STYLE, SIZE, OR COLOR.

FOR CHEMICAL FUEL ADDITIVES FOR DIESEL ENGINES, NAMELY, BLENDS AND MULTIPLE CHEMICAL FORMULATIONS THAT CAN REMOVE CARBON AND IMPROVE PERFORMANCE (U.S. CLS. 1, 5, 6, 10, 26 AND 46).

FIRST USE 10-19-2009; IN COMMERCE 11-3-2009.



3,941,766. EPICORE BIONETWORKS INC., EASTHAMPTON, NJ. SN 77-913,255. PUB. 6-1-2010, FILED 1-15-2010.

# PHYTO-STIM

THE MARK CONSISTS OF STANDARD CHARACTERS WITHOUT CLAIM TO ANY PARTICULAR FONT, STYLE, SIZE, OR COLOR.

FOR MICROBIAL SOIL AMENDMENTS FOR BETTER PLANT GROWTH AND INCREASED CROP YIELDS (U.S. CLS. 1, 5, 6, 10, 26 AND 46).

FIRST USE 1-13-2011; IN COMMERCE 1-13-2011.



3,941,911. HERCULES INCORPORATED, WILMINGTON, DE. SN 77-939,683. PUB. 7-13-2010, FILED 2-19-2010.

# BLUAGRO

THE MARK CONSISTS OF STANDARD CHARACTERS WITHOUT CLAIM TO ANY PARTICULAR FONT, STYLE, SIZE, OR COLOR.

FOR CHEMICAL FERTILIZERS (U.S. CLS. 1, 5, 6, 10, 26 AND 46).

FIRST USE 10-25-2010; IN COMMERCE 10-25-2010.

**CLASS 1—(Continued).**

3,941,999. GREEN AG FARMING PRODUCTS, LLC, WINSTON-SALEM, NC. SN 77-969,288. PUB. 8-17-2010, FILED 3-26-2010.

# Green-Root-Booster

THE MARK CONSISTS OF STANDARD CHARACTERS WITHOUT CLAIM TO ANY PARTICULAR FONT, STYLE, SIZE, OR COLOR.

FOR SOIL SURFACTANT USED TO PROMOTE UNIFORM MOVEMENT OF WATER IN SOIL (U.S. CLS. 1, 5, 6, 10, 26 AND 46).

FIRST USE 9-1-2010; IN COMMERCE 9-1-2010.



3,942,196. MIRUS BIO LLC, MADISON, WI. SN 85-049,551. PUB. 11-16-2010, FILED 5-27-2010.

# TRANSIT-PRO

THE MARK CONSISTS OF STANDARD CHARACTERS WITHOUT CLAIM TO ANY PARTICULAR FONT, STYLE, SIZE, OR COLOR.

FOR A KIT CONTAINING A TRANSFECTION REAGENT AND A BOOST FOR CHEMICAL AND BIOLOGICAL RESEARCH (U.S. CLS. 1, 5, 6, 10, 26 AND 46).

FIRST USE 5-27-2010; IN COMMERCE 12-1-2010.



3,942,298. ADVANCED POLYMER, INC., CARLSTADT, NJ. SN 85-080,700. PUB. 12-7-2010, FILED 7-8-2010.

# AdvaPel

THE MARK CONSISTS OF STANDARD CHARACTERS WITHOUT CLAIM TO ANY PARTICULAR FONT, STYLE, SIZE, OR COLOR.

FOR STAIN REPELLENTS FOR FABRIC, LEATHER, UPHOLSTERY, NATURAL STONE, TILE, GROUT, CONCRETE (U.S. CLS. 1, 5, 6, 10, 26 AND 46).

FIRST USE 7-1-2010; IN COMMERCE 7-1-2010.



**CLASS 2—PAINTS**

**CLASS 2—(Continued).**

3,941,093. CHARTPAK, INC., MELVILLE, NY. SN 77-494,171.  
PUB. 11-25-2008, FILED 6-9-2008.

**COLOR FACTORY**

THE MARK CONSISTS OF STANDARD CHARACTERS WITHOUT CLAIM TO ANY PARTICULAR FONT, STYLE, SIZE, OR COLOR.

NO CLAIM IS MADE TO THE EXCLUSIVE RIGHT TO USE "COLOR", APART FROM THE MARK AS SHOWN.

FOR PAINT SETS FOR ARTISTS (U.S. CLS. 6, 11 AND 16).

FIRST USE 10-20-2010; IN COMMERCE 10-20-2010.

3,941,546. JONES-BLAIR COMPANY, DALLAS, TX. SN 77-868,434. PUB. 4-27-2010, FILED 11-9-2009.



THE COLOR(S) RED, WHITE, AND BLACK IS/ARE CLAIMED AS A FEATURE OF THE MARK.

THE MARK CONSISTS OF AN "R" IN RED AND WHITE STYLIZED FORM WITH A RED AND WHITE ARROW RISING OUT OF THE BOTTOM RIGHT SIDE OF THE "R", WITHIN A SHADED RED RECTANGLE DESIGN, ALL ABOVE THE TERM, "RUSTNOT" IN BLACK STYLIZED FORM.

FOR PROTECTIVE COATINGS FOR USE ON PAIN-TABLE METAL SURFACES, NAMELY, EPOXY COAT-INGS, LATEX COATINGS, URETHANE COATINGS, AND ZINC COATINGS (U.S. CLS. 6, 11 AND 16).

FIRST USE 10-15-2010; IN COMMERCE 10-15-2010.

3,941,706. GRIMCO, INC., FENTON, MO. SN 77-902,682. PUB. 5-18-2010, FILED 12-30-2009.

**20/20 COLOR**

THE MARK CONSISTS OF STANDARD CHARACTERS WITHOUT CLAIM TO ANY PARTICULAR FONT, STYLE, SIZE, OR COLOR.

NO CLAIM IS MADE TO THE EXCLUSIVE RIGHT TO USE "COLOR", APART FROM THE MARK AS SHOWN.

FOR PRINTERS' INK (U.S. CLS. 6, 11 AND 16).

FIRST USE 3-1-2010; IN COMMERCE 3-1-2010.

**CLASS 2—(Continued).**

3,941,707. GRIMCO, INC., FENTON, MO. SN 77-902,700. PUB. 5-18-2010, FILED 12-30-2009.



NO CLAIM IS MADE TO THE EXCLUSIVE RIGHT TO USE "COLOR", APART FROM THE MARK AS SHOWN.

THE COLOR(S) GREEN, BLACK, WHITE AND ORANGE IS/ARE CLAIMED AS A FEATURE OF THE MARK.

THE MARK CONSISTS OF THE FRACTION "20/20" IN WHITE APPEARING IN THE CENTER OF A GREEN CIRCLE AND WHITE CIRCLES WITH ORANGE DOTTED LINES APPEARING AT THE BOTTOM LEFT SIDE OF THE GREEN CIRCLE. ADJACENT TO THE GREEN CIRCLE IS THE WORD "COLOR" WHICH APPEARS IN BLACK LETTERS, EXCEPT THE FIRST "O" WHICH APPEARS IN GREEN. DIRECTLY BELOW THE WORD "COLOR", APPEARS A BLACK BAR. WITHIN THE BLACK BAR, THE WORDS "TWENTY TWENTY" APPEAR IN WHITE, SEPA-RATED BY A WHITE DOT.

FOR PRINTERS' INK (U.S. CLS. 6, 11 AND 16).

FIRST USE 3-1-2010; IN COMMERCE 3-1-2010.

3,941,839. DAP BRANDS COMPANY, MEDINA, OH. SN 77-924,914. PUB. 8-10-2010, FILED 2-1-2010.

**DAP PRIMER 920**

THE MARK CONSISTS OF STANDARD CHARACTERS WITHOUT CLAIM TO ANY PARTICULAR FONT, STYLE, SIZE, OR COLOR.

NO CLAIM IS MADE TO THE EXCLUSIVE RIGHT TO USE "PRIMER 920", APART FROM THE MARK AS SHOWN.

FOR A QUICK-DRYING, SOLVENT-BASED PRIMER FOR PRIMING JOINTS AND BUILDING SURFACES PRIOR TO INSTALLATION OF SEALANTS THAT MEET OR EXCEED ESTABLISHED INDUSTRY STANDARDS AND SPECIFICATIONS (U.S. CLS. 6, 11 AND 16).

FIRST USE 8-1-2010; IN COMMERCE 8-1-2010.

3,941,975. SUPERIOR FINISHES OF AMERICA, LLC, DEL MAR, CA. SN 77-959,921. PUB. 9-7-2010, FILED 3-16-2010.



NO CLAIM IS MADE TO THE EXCLUSIVE RIGHT TO USE "SUPERIOR FINISHES OF AMERICA", APART FROM THE MARK AS SHOWN.

**CLASS 2—(Continued).**

THE MARK CONSISTS OF THE LETTERS "S" AND "F" IN BLOCK FORMAT, THE LETTER "A" IN BLOCK FORMAT AND COMPRISING THE AMERICAN FLAG, AND THE WORDS "SUPERIOR FINISHES OF AMERICA" DIRECTLY BELOW THE LETTERS "S", "F" AND "A".

FOR PAINTS; COATINGS, NAMELY, EXTERIOR SURFACE PROTECTIVE COATINGS (U.S. CLS. 6, 11 AND 16).

FIRST USE 7-13-2010; IN COMMERCE 7-13-2010.

---

3,941,994. MITSUBISHI KAGAKU IMAGING CORPORATION, CHESAPEAKE, VA. SN 77-966,050. PUB. 8-10-2010, FILED 3-23-2010.

TRUE BLACK FOR A GREENER  
PLANET

THE MARK CONSISTS OF STANDARD CHARACTERS WITHOUT CLAIM TO ANY PARTICULAR FONT, STYLE, SIZE, OR COLOR.

FOR PRINTER, COPIER AND FACSIMILE MACHINE SUPPLIES, NAMELY, TONER (U.S. CLS. 6, 11 AND 16).  
FIRST USE 9-29-2010; IN COMMERCE 9-29-2010.

---

3,942,126. SUPERIOR FINISHES OF AMERICA, LLC, DEL MAR, CA. SN 85-024,176. PUB. 8-24-2010, FILED 4-27-2010.

OPUS

THE MARK CONSISTS OF STANDARD CHARACTERS WITHOUT CLAIM TO ANY PARTICULAR FONT, STYLE, SIZE, OR COLOR.

FOR PAINTS; COATINGS, NAMELY, EXTERIOR SURFACE PROTECTIVE COATINGS (U.S. CLS. 6, 11 AND 16).

FIRST USE 7-13-2010; IN COMMERCE 7-13-2010.

**CLASS 2—(Continued).**

3,942,173. EVP INTERNATIONAL, LLC, LOVELAND, OH. SN 85-044,260. PUB. 11-30-2010, FILED 5-20-2010.

MN8

THE MARK CONSISTS OF STANDARD CHARACTERS WITHOUT CLAIM TO ANY PARTICULAR FONT, STYLE, SIZE, OR COLOR.

FOR PHOTO-LUMINESCENT OR "GLOW-IN-THE-DARK" PAINTS AND EPOXY COATINGS (U.S. CLS. 6, 11 AND 16).

FIRST USE 9-23-2010; IN COMMERCE 9-23-2010.

**CLASS 3—COSMETICS AND CLEANING PREPARATIONS**

3,940,985. TURMAN, GENEVA, RANCHO SANTA MARGARITA, CA. SN 76-690,776. PUB. 12-9-2008, FILED 6-23-2008.

PEDI-CURE-IT

THE MARK CONSISTS OF STANDARD CHARACTERS WITHOUT CLAIM TO ANY PARTICULAR FONT, STYLE, SIZE, OR COLOR.

FOR NON-MEDICATED FOOT CARE PRODUCTS, NAMELY, REVITALIZING AND CLEANSING PREPARATIONS FOR FOOT BATHS, FOOT SOAKS, FOOT SCRUBS, CUTICLE-REMOVER CREAMS, MOISTURIZING LOTIONS, COOLING LOTIONS, FOOT CREAMS, FOOT MASKS, CLEANSING GRAINS, NON-MEDICATED FOOT POWDER, SCENTED FOOT SPRAYS, AROMATHERAPY OILS, NON-MEDICATED BATH SALTS; FINGERNAIL PRODUCTS, NAMELY, POLISH BASE COAT, TOP COAT, NAIL POLISH, NAIL POLISH REMOVER, CREAM STRENGTHENERS, NAIL HARDENER, NAIL CONDITIONERS (U.S. CLS. 1, 4, 6, 50, 51 AND 52).

FIRST USE 8-20-2010; IN COMMERCE 8-20-2010.

---

3,940,992. EXIT, LTD., LINDEN, NJ. SN 76-698,482. PUB. 12-29-2009, FILED 7-17-2009.

ENTRANCE

THE MARK CONSISTS OF STANDARD CHARACTERS WITHOUT CLAIM TO ANY PARTICULAR FONT, STYLE, SIZE, OR COLOR.

FOR HAIR CARE PREPARATION MADE OF ARGAN OIL (U.S. CLS. 1, 4, 6, 50, 51 AND 52).

FIRST USE 12-7-2010; IN COMMERCE 12-7-2010.

**CLASS 3—(Continued).**

3,941,003. JASON & JEAN PRODUCTS INC., CORONA, NY.  
SN 76-702,133. PUB. 11-9-2010, FILED 3-18-2010.

**NATTY SUPER HAIR WEAVING BOND**

THE MARK CONSISTS OF STANDARD CHARACTERS WITHOUT CLAIM TO ANY PARTICULAR FONT, STYLE, SIZE, OR COLOR.

OWNER OF U.S. REG. NOS. 2,648,907, 3,617,986, AND OTHERS.

NO CLAIM IS MADE TO THE EXCLUSIVE RIGHT TO USE "SUPER HAIR WEAVING BOND", APART FROM THE MARK AS SHOWN.

FOR HAIR STYLING GEL; ADHESIVE FOR USE WITH HAIR PIECES; ADHESIVE REMOVERS, NAMELY, HAIR BOND REMOVER FOR REMOVING ADHESIVES FROM HAIR (U.S. CLS. 1, 4, 6, 50, 51 AND 52).

FIRST USE 3-6-1992; IN COMMERCE 3-6-1992.

**CLASS 3—(Continued).**

3,941,098. BUOY, ROGER, SOMERSET, UNITED KINGDOM.  
SN 77-508,895. PUB. 5-5-2009, FILED 6-26-2008.

**THE HAIR ACADEMY**

THE MARK CONSISTS OF STANDARD CHARACTERS WITHOUT CLAIM TO ANY PARTICULAR FONT, STYLE, SIZE, OR COLOR.

NO CLAIM IS MADE TO THE EXCLUSIVE RIGHT TO USE "HAIR", APART FROM THE MARK AS SHOWN.

FOR NON-MEDICATED HAIR CARE PREPARATIONS; HAIR SHAMPOOS AND CONDITIONERS (U.S. CLS. 1, 4, 6, 50, 51 AND 52).

FIRST USE 11-3-2010; IN COMMERCE 12-21-2010.

3,941,053. DERMACARE NEUROSCIENCE INSTITUTE,  
BEVERLY HILLS, CA. SN 77-326,337. PUB. 5-20-2008,  
FILED 11-9-2007.

**DNI**

THE MARK CONSISTS OF STANDARD CHARACTERS WITHOUT CLAIM TO ANY PARTICULAR FONT, STYLE, SIZE, OR COLOR.

FOR NON-MEDICATED SKIN CARE PREPARATIONS; COSMETICS (U.S. CLS. 1, 4, 6, 50, 51 AND 52).

FIRST USE 1-15-2011; IN COMMERCE 1-15-2011.

3,941,122. THE PROCTER & GAMBLE COMPANY, CINCINNATI, OH. SN 77-547,782. PUB. 12-30-2008, FILED 8-15-2008.

**TRUTH OR PEAR**

THE MARK CONSISTS OF STANDARD CHARACTERS WITHOUT CLAIM TO ANY PARTICULAR FONT, STYLE, SIZE, OR COLOR.

FOR ANTIPERSPIRANTS AND DEODORANTS FOR PERSONAL USE; BODY SPRAYS (U.S. CLS. 1, 4, 6, 50, 51 AND 52).

FIRST USE 2-9-2009; IN COMMERCE 2-9-2009.

3,941,088. MANA PRODUCTS, INC., LONG ISLAND CITY,  
NY. SN 77-477,848. PUB. 10-21-2008, FILED 5-19-2008.

**Ultra Matte Fix**

THE MARK CONSISTS OF STANDARD CHARACTERS WITHOUT CLAIM TO ANY PARTICULAR FONT, STYLE, SIZE, OR COLOR.

FOR COSMETICS (U.S. CLS. 1, 4, 6, 50, 51 AND 52).

FIRST USE 5-31-2008; IN COMMERCE 5-31-2008.

3,941,136. KISS NAIL PRODUCTS, INC., PORT WASHINGTON, NY. SN 77-575,334. PUB. 6-15-2010, FILED 9-22-2008.

**I-Envy**

THE MARK CONSISTS OF STANDARD CHARACTERS WITHOUT CLAIM TO ANY PARTICULAR FONT, STYLE, SIZE, OR COLOR.

FOR FALSE EYELASHES (U.S. CLS. 1, 4, 6, 50, 51 AND 52).

FIRST USE 5-9-2009; IN COMMERCE 5-9-2009.

**CLASS 3—(Continued).**

3,941,137. KISS NAIL PRODUCTS, INC., PORT WASHINGTON, NY. SN 77-575,337. PUB. 6-15-2010, FILED 9-22-2008.

**I-Envy by Kiss**

THE MARK CONSISTS OF STANDARD CHARACTERS WITHOUT CLAIM TO ANY PARTICULAR FONT, STYLE, SIZE, OR COLOR.

OWNER OF U.S. REG. NOS. 2,616,120, 3,104,904, AND 3,367,734.  
FOR FALSE EYELASHES (U.S. CLS. 1, 4, 6, 50, 51 AND 52).  
FIRST USE 5-9-2009; IN COMMERCE 5-9-2009.



3,941,142. PHILOSOPHY, INC., PHOENIX, AZ. SN 77-584,344. PUB. 12-9-2008, FILED 10-2-2008.

**PHILOSOPHY BEST SELLERS**

THE MARK CONSISTS OF STANDARD CHARACTERS WITHOUT CLAIM TO ANY PARTICULAR FONT, STYLE, SIZE, OR COLOR.

OWNER OF U.S. REG. NOS. 2,016,208, 2,214,968, AND 3,406,516.  
NO CLAIM IS MADE TO THE EXCLUSIVE RIGHT TO USE "BEST SELLERS", APART FROM THE MARK AS SHOWN.  
FOR HAIR CARE PREPARATIONS; NON-MEDICATED SKIN CARE PREPARATIONS; SHOWER AND BATH GEL (U.S. CLS. 1, 4, 6, 50, 51 AND 52).  
FIRST USE 11-25-2008; IN COMMERCE 11-25-2008.



3,941,184. KATE SOMERVILLE SKIN CARE LLC, LOS ANGELES, CA. SN 77-639,147. PUB. 11-10-2009, FILED 12-23-2008.

**COMPLEXION CORRECTION**

THE MARK CONSISTS OF STANDARD CHARACTERS WITHOUT CLAIM TO ANY PARTICULAR FONT, STYLE, SIZE, OR COLOR.

NO CLAIM IS MADE TO THE EXCLUSIVE RIGHT TO USE "COMPLEXION", APART FROM THE MARK AS SHOWN.  
FOR SKIN WHITENING KITS COMPRISING SKIN WHITENING PREPARATIONS AND APPLICATORS THEREFOR (U.S. CLS. 1, 4, 6, 50, 51 AND 52).  
FIRST USE 7-31-2010; IN COMMERCE 7-31-2010.

**CLASS 3—(Continued).**

3,941,206. ADERANS HAIR GOODS, INC., BEVERLY HILLS, CA. SN 77-658,286. PUB. 11-23-2010, FILED 1-28-2009.

**OnQue**

THE MARK CONSISTS OF STANDARD CHARACTERS WITHOUT CLAIM TO ANY PARTICULAR FONT, STYLE, SIZE, OR COLOR.

FOR HAIR AND HAIRPIECE CARE PRODUCTS, NAMELY, SHAMPOOS, CONDITIONERS, CLEANERS, LUSTERIZERS, GELS AND SPRAYS (U.S. CLS. 1, 4, 6, 50, 51 AND 52).  
FIRST USE 7-23-2009; IN COMMERCE 7-23-2009.



3,941,224. TUPPERWARE PRODUCTS S.A., FRIBOURG CH-1700, SWITZERLAND. SN 77-669,814. PUB. 4-21-2009, FILED 2-13-2009.

**FITZMANN**

THE MARK CONSISTS OF STANDARD CHARACTERS WITHOUT CLAIM TO ANY PARTICULAR FONT, STYLE, SIZE, OR COLOR.

FOR PERFUMERY (U.S. CLS. 1, 4, 6, 50, 51 AND 52).  
FIRST USE 7-2-2009; IN COMMERCE 7-2-2009.



3,941,232. ADVANTAGE DIRECT INTERNATIONAL, INC., RYE, NY. SN 77-680,682. PUB. 8-18-2009, FILED 2-27-2009.

The logo for 'depi|silk' features a stylized blue circle on the left containing a white leaf-like shape. To its right, the word 'depi|silk' is written in a lowercase, sans-serif font. The 'depi' part is in black, followed by a vertical bar, and 'silk' is in blue.

THE COLOR(S) BLACK AND BLUE IS/ARE CLAIMED AS A FEATURE OF THE MARK.

THE MARK CONSISTS OF A CIRCLE DIVIDED IN HALF WITH A LEAF SHAPED DESIGN IN THE MIDDLE, WITH THE TWO PARTS OF THE CIRCLE IN BLUE; THE WORD "DEPIL" IN SMALL BLACK CHARACTERS; AND THE WORD "SILK" IN SMALL BLUE CHARACTERS WITH A BLUE OUTLINE.  
FOR DEPILATORIES (U.S. CLS. 1, 4, 6, 50, 51 AND 52).  
FIRST USE 4-1-2009; IN COMMERCE 4-1-2009.

**CLASS 3—(Continued).**

3,941,240. BREMENN IP HOLDINGS, LLC, CARSON CITY, NV. SN 77-694,251. PUB. 5-12-2009, FILED 3-18-2009.

**CLASS 3—(Continued).**

3,941,302. KHADI NATURPRODUKTE GMBH, RINTELN, FED REP GERMANY. SN 77-758,991. PUB. 5-11-2010, FILED 6-13-2009.

**TUMMY TUCK IN A BOX**

THE MARK CONSISTS OF STANDARD CHARACTERS WITHOUT CLAIM TO ANY PARTICULAR FONT, STYLE, SIZE, OR COLOR.  
FOR COSMETICS (U.S. CLS. 1, 4, 6, 50, 51 AND 52).  
FIRST USE 11-3-2010; IN COMMERCE 11-3-2010.

---

3,941,267. NOXELL CORPORATION, HUNT VALLEY, MD. SN 77-731,111. PUB. 11-24-2009, FILED 5-7-2009.

**SHINESCULPT**

THE MARK CONSISTS OF STANDARD CHARACTERS WITHOUT CLAIM TO ANY PARTICULAR FONT, STYLE, SIZE, OR COLOR.  
FOR COSMETIC APPLICATORS SOLD AS A COMPONENT OF LIP GLOSS AND LIPSTICKS (U.S. CLS. 1, 4, 6, 50, 51 AND 52).  
FIRST USE 8-1-2010; IN COMMERCE 8-1-2010.

---

3,941,281. THE PROCTER & GAMBLE COMPANY, CINCINNATI, OH. SN 77-747,738. PUB. 9-29-2009, FILED 5-29-2009.

**TOUCHABLY SMOOTH**

THE MARK CONSISTS OF STANDARD CHARACTERS WITHOUT CLAIM TO ANY PARTICULAR FONT, STYLE, SIZE, OR COLOR.  
FOR HAIR CARE PREPARATIONS (U.S. CLS. 1, 4, 6, 50, 51 AND 52).  
FIRST USE 11-30-2010; IN COMMERCE 11-30-2010.



**khadi**

Natural Products  
from India

NO CLAIM IS MADE TO THE EXCLUSIVE RIGHT TO USE "NATURAL PRODUCTS FROM INDIA", APART FROM THE MARK AS SHOWN.

THE MARK CONSISTS OF ROUND LOGO OF PRAJNA "KHADI NATURAL PRODUCTS FROM INDIA".

FOR AGE SPOT REDUCING CREAMS; ANTI-AGING CREAM; ANTI-AGING CREAMS; ANTI-WRINKLE CREAM; ANTI-WRINKLE CREAMS; BABY OIL; BABY OILS; BABY SHAMPOO; BATH OIL; BATH OILS; BATH OILS AND BATH SALTS; BATH OILS FOR COSMETIC PURPOSES; BEAUTY CREAMS; BEAUTY CREAMS FOR BODY CARE; BODY CREAM; BODY CREAM SOAP; BODY CREAMS; BODY LOTION; BODY MASK CREAM; BODY MASK POWDER; BODY MASKS; BODY MILKS; BODY OIL; BODY OILS; BODY POWDER; BODY SCRUB; BODY SPLASH; BODY WASHES; BOOT CREAM; CLEANSING CREAMS; COSMETIC CREAMS; COSMETIC CREAMS FOR SKIN CARE; COSMETIC OILS; CREAMS FOR CELLULITE REDUCTION; ESSENTIAL OILS; FACE CREAMS; FACE CREAMS FOR COSMETIC USE; FACIAL CREAM; FACIAL CREAMS; HAIR CARE CREAMS; HAIR CARE LOTIONS; HAIR COLORANTS; HAIR COLORING PREPARATIONS; HAIR COLORANTS; HAIR COLORING; HAIR COLORING AND DYES; HAIR CONDITIONER; HAIR DYE; HAIR DYES; HAIR GELS; HAIR OILS; HAIR SHAMPOO; HAIR TONIC; HAIR TONICS; HAIR-WASHING POWDER; SHAMPOO-CONDITIONERS; SHAMPOOS; SHAMPOOS FOR BABIES (U.S. CLS. 1, 4, 6, 50, 51 AND 52).  
FIRST USE 1-15-2007; IN COMMERCE 6-30-2007.



**CLASS 3—(Continued).**

3,941,306. WILBUR PRODUCTS, INC., SPRING LAKE, MI. SN 77-761,054. PUB. 5-25-2010, FILED 6-16-2009.

**GRIME SCENE**

THE MARK CONSISTS OF STANDARD CHARACTERS WITHOUT CLAIM TO ANY PARTICULAR FONT, STYLE, SIZE, OR COLOR.

FOR HAND, FACE, AND BODY WASHES AND CLEANERS; HEAVY DUTY CLEANERS AND DEGREASERS NOT USED IN THE MANUFACTURING PROCESS FOR USE ON ENGINES; HEAVY DUTY CLEANERS, NAMELY, GARAGE FLOOR CLEANERS AND STAIN REMOVERS; CLEANERS FOR BOAT BILGES; CLEANERS FOR PARTS WASHERS, NAMELY, CLEANERS FOR PARTS OF TOOLS, MACHINERY, MANUFACTURING EQUIPMENT, MOLDED PRODUCTS, MACHINED PRODUCTS, AND CAST PRODUCTS; HEAVY DUTY CLEANERS, NAMELY, INDUSTRIAL FLOOR CLEANERS; STAIN REMOVERS; CLEANING PREPARATIONS FOR THE REMOVAL OF GRAFFITI; GRAFFITI REMOVERS IN THE NATURE OF PAINT REMOVERS; AND CLEANING PREPARATIONS IN THE NATURE OF GRILL CLEANSERS (U.S. CLS. 1, 4, 6, 50, 51 AND 52).  
FIRST USE 4-6-2010; IN COMMERCE 4-6-2010.

3,941,341. L'OREAL, PARIS, FRANCE. SN 77-773,043. PUB. 4-6-2010, FILED 7-2-2009.

**GO 360° CLEAN**

THE MARK CONSISTS OF STANDARD CHARACTERS WITHOUT CLAIM TO ANY PARTICULAR FONT, STYLE, SIZE, OR COLOR.

NO CLAIM IS MADE TO THE EXCLUSIVE RIGHT TO USE "CLEAN", APART FROM THE MARK AS SHOWN.

FOR FACIAL CLEANSER (U.S. CLS. 1, 4, 6, 50, 51 AND 52).

FIRST USE 12-1-2009; IN COMMERCE 12-1-2009.

3,941,369. IMASTAR CORPORATION, WEST HOLLYWOOD, CA. SN 77-783,440. PUB. 10-6-2009, FILED 7-17-2009.

**NOX**

THE MARK CONSISTS OF STANDARD CHARACTERS WITHOUT CLAIM TO ANY PARTICULAR FONT, STYLE, SIZE, OR COLOR.

FOR COSMETICS (U.S. CLS. 1, 4, 6, 50, 51 AND 52).  
FIRST USE 3-31-2010; IN COMMERCE 3-31-2010.

**CLASS 3—(Continued).**

3,941,401. BATH & BODY WORKS BRAND MANAGEMENT, INC., REYNOLDSBURG, OH. SN 77-796,665. PUB. 11-3-2009, FILED 8-4-2009.

**HOT SUMMER CRUSH**

THE MARK CONSISTS OF STANDARD CHARACTERS WITHOUT CLAIM TO ANY PARTICULAR FONT, STYLE, SIZE, OR COLOR.

FOR PERSONAL CARE PRODUCTS, NAMELY, BODY LOTION; BODY WASH; FRAGRANCE MIST; BODY MOUSSE; NON-MEDICATED LIP CARE PREPARATIONS (U.S. CLS. 1, 4, 6, 50, 51 AND 52).

FIRST USE 5-10-2010; IN COMMERCE 5-10-2010.

3,941,415. INVERSORA LUMIRT S.A., MONTEVIDEO, URUGUAY. SN 77-801,942. PUB. 6-15-2010, FILED 8-11-2009.

**BONMETIQUE**

THE MARK CONSISTS OF STANDARD CHARACTERS WITHOUT CLAIM TO ANY PARTICULAR FONT, STYLE, SIZE, OR COLOR.

THE WORDING "BONMETIQUE" HAS NO MEANING IN A FOREIGN LANGUAGE.

FOR HAIR COLOR PREPARATIONS, NAMELY, HAIR DYES, HAIR COLORS, HAIR BLEACH, HAIR COLOR REMOVERS, HAIR CREAMS, HAIR DECOLORANTS, RED INTENSIFIERS; HAIR CARE PREPARATIONS, NAMELY, SHAMPOOS, CONDITIONERS, NON-MEDICATED LINEN OIL HAIR SERUM; STYLING PREPARATIONS, NAMELY, HAIR STYLING SPRAY, STYLING LOTION, STYLING GEL, HAIR STYLING WAX, STYLING MOUSSE (U.S. CLS. 1, 4, 6, 50, 51 AND 52).

FIRST USE 9-28-1998; IN COMMERCE 7-15-2010.

3,941,436. PRODUCT INNOVATIONS RESEARCH LLC, DALLAS, TX. SN 77-810,358. PUB. 11-10-2009, FILED 8-21-2009.

**bronzology**

THE MARK CONSISTS OF STANDARD CHARACTERS WITHOUT CLAIM TO ANY PARTICULAR FONT, STYLE, SIZE, OR COLOR.

FOR INDOOR AND OUTDOOR TANNING PRODUCTS, NAMELY, NON-MEDICATED TAN DARKENING LOTIONS AND SKIN MOISTURIZERS (U.S. CLS. 1, 4, 6, 50, 51 AND 52).

FIRST USE 11-1-2009; IN COMMERCE 11-1-2009.

**CLASS 3—(Continued).**

3,941,447. HERON VENTURES, LTD., DBA NATURAL BEAUTY GROUP, LA CONNER, WA. SN 77-818,699. PUB. 10-26-2010, FILED 9-2-2009.

ORGANIC  
MALE 

NO CLAIM IS MADE TO THE EXCLUSIVE RIGHT TO USE "ORGANIC MALE", APART FROM THE MARK AS SHOWN.

THE MARK CONSISTS OF THE WORDS "ORGANIC" AND "MALE", BOTH WORDS JUSTIFIED TO THE RIGHT; THE NUMBER "4" ENCASED IN A SHADED BOX THE FULL HEIGHT OF THE MARK; THE LETTERS "O" AND "M" LOCATED UNDER THE HORIZONTAL LINE OF THE NUMBER "4" AND TO THE LEFT OF THE LOWER VERTICAL LINE OF THE NUMBER "4".

FOR ORGANIC COSMETICS (U.S. CLS. 1, 4, 6, 50, 51 AND 52).

FIRST USE 12-1-2009; IN COMMERCE 12-1-2009.

3,941,495. L'OREAL USA CREATIVE, INC., NEW YORK, NY. SN 77-847,278. PUB. 12-15-2009, FILED 10-13-2009.

MICRO BOOST

THE MARK CONSISTS OF STANDARD CHARACTERS WITHOUT CLAIM TO ANY PARTICULAR FONT, STYLE, SIZE, OR COLOR.

FOR NON-MEDICATED HAIR TREATMENT PREPARATION (U.S. CLS. 1, 4, 6, 50, 51 AND 52).

FIRST USE 1-0-2011; IN COMMERCE 1-0-2011.

3,941,497. PACIFIC SPECIALTY OILS, INC., MOUNTAIN VIEW, CA. SN 77-848,937. PUB. 6-1-2010, FILED 10-14-2009.

*Hide the Years*  
HTY  
GOLD

PREVENT & CONQUER  
Dry, Wrinkled, Crepe-Paper Skin!

OWNER OF U.S. REG. NOS. 2,887,210, 3,675,470, AND OTHERS.

**CLASS 3—(Continued).**

THE MARK CONSISTS OF "HIDE THE YEARS" IN SCRIPT TYPE FACE, "HTY" AND "GOLD" ARE IN CUSTOMIZED TYPE FACE. BENEATH THE WORD "GOLD" IS A DECORATIVE ELEMENT; AND BENEATH THE DECORATIVE ELEMENT IS THE TAG LINE "PREVENT & CONQUER DRY, WRINKLED, CREPE-PAPER SKIN!".

FOR NON-MEDICATED CREAMS FOR THE FACE, HANDS, FEET, AND BODY; SOAP; SKIN CONDITIONERS (U.S. CLS. 1, 4, 6, 50, 51 AND 52).

FIRST USE 7-2-2007; IN COMMERCE 7-2-2007.

3,941,519. L'OREAL USA CREATIVE, INC., NEW YORK, NY. SN 77-857,477. PUB. 12-22-2009, FILED 10-26-2009.

FASHION WORK

THE MARK CONSISTS OF STANDARD CHARACTERS WITHOUT CLAIM TO ANY PARTICULAR FONT, STYLE, SIZE, OR COLOR.

FOR HAIR STYLING PREPARATION (U.S. CLS. 1, 4, 6, 50, 51 AND 52).

FIRST USE 11-0-2010; IN COMMERCE 11-0-2010.

3,941,580. R3 DESIGN LLC, NAHANT, MA. SN 77-878,433. PUB. 4-27-2010, FILED 11-23-2009.

ILKA

THE MARK CONSISTS OF STANDARD CHARACTERS WITHOUT CLAIM TO ANY PARTICULAR FONT, STYLE, SIZE, OR COLOR.

FOR HAIR CREAMS; HAIR MOUSSES; HAIR SHAMPOOS AND CONDITIONERS; HAIR SPRAYS AND HAIR GELS (U.S. CLS. 1, 4, 6, 50, 51 AND 52).

FIRST USE 1-29-2010; IN COMMERCE 4-19-2010.

3,941,589. HENKEL CONSUMER GOODS INC., SCOTTSDALE, AZ. SN 77-879,557. PUB. 6-29-2010, FILED 11-24-2009.

NUTRA CURL

THE MARK CONSISTS OF STANDARD CHARACTERS WITHOUT CLAIM TO ANY PARTICULAR FONT, STYLE, SIZE, OR COLOR.

**CLASS 3—(Continued).**

NO CLAIM IS MADE TO THE EXCLUSIVE RIGHT TO USE "CURL", APART FROM THE MARK AS SHOWN.  
FOR HAIR STYLING PREPARATIONS (U.S. CLS. 1, 4, 6, 50, 51 AND 52).  
FIRST USE 12-8-2010; IN COMMERCE 12-8-2010.

**CLASS 3—(Continued).**

3,941,626. ACI, INC., NEW YORK, NY. SN 77-889,714. PUB. 10-19-2010, FILED 12-9-2009.

**READY TO WEAR**

THE MARK CONSISTS OF STANDARD CHARACTERS WITHOUT CLAIM TO ANY PARTICULAR FONT, STYLE, SIZE, OR COLOR.

FOR BLUSHERS, FACE POWDER, FOUNDATIONS, LIPSTICKS, LIP GLOSSES, EYE MASCARA, EYE LASH LENGTHENER, EYE PENCILS (U.S. CLS. 1, 4, 6, 50, 51 AND 52).

FIRST USE 7-9-2007; IN COMMERCE 7-9-2007.

3,941,605. M S PARR ENTERPRISES INC., CHICAGO, IL. SN 77-882,988. PUB. 5-18-2010, FILED 12-1-2009.

**NOTACHIP**

THE MARK CONSISTS OF STANDARD CHARACTERS WITHOUT CLAIM TO ANY PARTICULAR FONT, STYLE, SIZE, OR COLOR.

FOR ULTRA VIOLET LIGHT ACTIVATING NAIL COATING IN THE NATURE OF ACRYLIC NAIL GELS (U.S. CLS. 1, 4, 6, 50, 51 AND 52).

FIRST USE 1-3-2011; IN COMMERCE 1-3-2011.

3,941,657. STILL LIFE SKIN, LLC, NEW YORK, NY. SN 77-895,396. PUB. 6-15-2010, FILED 12-17-2009.

**love life skin**

THE MARK CONSISTS OF STANDARD CHARACTERS WITHOUT CLAIM TO ANY PARTICULAR FONT, STYLE, SIZE, OR COLOR.

NO CLAIM IS MADE TO THE EXCLUSIVE RIGHT TO USE "SKIN", APART FROM THE MARK AS SHOWN.

FOR SKINCARE PRODUCTS, NAMELY, CLEANSERS, MOISTURIZERS, SOAP, SKIN TONICS, BATH AND BODY FRAGRANCE (U.S. CLS. 1, 4, 6, 50, 51 AND 52).

FIRST USE 2-1-2011; IN COMMERCE 2-1-2011.

3,941,614. DRISSEQ, NADINE, RENTON, WA. SN 77-884,417. PUB. 4-27-2010, FILED 12-2-2009.

**INCENDIARY ARTS**

THE MARK CONSISTS OF STANDARD CHARACTERS WITHOUT CLAIM TO ANY PARTICULAR FONT, STYLE, SIZE, OR COLOR.

FOR BATH HERBS; ESSENTIAL OILS; INCENSE; INCENSE STICKS; PLANT AND HERB EXTRACTS SOLD AS COMPONENTS OF COSMETICS; SCENTED OILS USED TO PRODUCE AROMAS WHEN HEATED (U.S. CLS. 1, 4, 6, 50, 51 AND 52).

FIRST USE 4-15-2010; IN COMMERCE 4-15-2010.

3,941,780. THE MOTHERVINE, LLC, CHARLOTTE, NC. SN 77-915,659. PUB. 6-8-2010, FILED 1-20-2010.

**MOTHERVINE SOOTHING BALM**

THE MARK CONSISTS OF STANDARD CHARACTERS WITHOUT CLAIM TO ANY PARTICULAR FONT, STYLE, SIZE, OR COLOR.

NO CLAIM IS MADE TO THE EXCLUSIVE RIGHT TO USE "SOOTHING BALM", APART FROM THE MARK AS SHOWN.

FOR NON-MEDICATED BALMS FOR USE ON SKIN (U.S. CLS. 1, 4, 6, 50, 51 AND 52).

FIRST USE 2-18-2010; IN COMMERCE 3-12-2010.

**CLASS 3—(Continued).**

3,941,781. THE MOTHERVINE, LLC, CHARLOTTE, NC. SN 77-915,699. PUB. 6-8-2010, FILED 1-20-2010.

**MOTHERVINE BOO BOO BALM**

THE MARK CONSISTS OF STANDARD CHARACTERS WITHOUT CLAIM TO ANY PARTICULAR FONT, STYLE, SIZE, OR COLOR.

NO CLAIM IS MADE TO THE EXCLUSIVE RIGHT TO USE "BOO BOO BALM", APART FROM THE MARK AS SHOWN.

FOR NON-MEDICATED BALMS FOR USE ON SKIN (U.S. CLS. 1, 4, 6, 50, 51 AND 52).

FIRST USE 2-18-2010; IN COMMERCE 3-12-2010.

3,941,787. COST PLUS MANAGEMENT SERVICES, INC., OAKLAND, CA. SN 77-916,718. PUB. 6-8-2010, FILED 1-21-2010.

**POMONA**

THE MARK CONSISTS OF STANDARD CHARACTERS WITHOUT CLAIM TO ANY PARTICULAR FONT, STYLE, SIZE, OR COLOR.

FOR BATH SOAPS IN LIQUID, SOLID OR GEL FORM; BODY LOTIONS; FACE AND BODY CREAMS; BATH SALTS (U.S. CLS. 1, 4, 6, 50, 51 AND 52).

FIRST USE 8-3-2010; IN COMMERCE 8-3-2010.

**CLASS 3—(Continued).**

3,941,834. SKINN COSMETICS, LLC, TORRANCE, CA. SN 77-922,797. PUB. 6-15-2010, FILED 1-28-2010.

**Bringing Beauty to the World**

THE MARK CONSISTS OF STANDARD CHARACTERS WITHOUT CLAIM TO ANY PARTICULAR FONT, STYLE, SIZE, OR COLOR.

FOR ANTI-AGING CLEANSER; ANTI-AGING MOISTURIZER; BODY AND BEAUTY CARE COSMETICS; CLEANSING CREAMS; COSMETIC CREAMS; COSMETIC CREAMS FOR SKIN CARE; COSMETIC MASKS; COSMETIC MILKS; COSMETIC OILS; COSMETIC OILS FOR THE EPIDERMIS; COSMETIC PENCILS; COSMETIC PREPARATIONS; COSMETIC PREPARATIONS FOR BODY CARE; COSMETIC PREPARATIONS FOR EYE LASHES; COSMETIC PREPARATIONS FOR SKIN RENEWAL; COSMETIC PREPARATIONS FOR SLIMMING PURPOSES; COSMETIC PREPARATIONS, NAMELY, FIRMING CREAMS; COSMETIC PREPARATIONS, NAMELY, FIRMING LOTIONS; COSMETIC ROUGES; COSMETICS; COSMETICS AND COSMETIC PREPARATIONS; COSMETICS AND MAKE-UP; COSMETICS, NAMELY, LIP PRIMER; CREAMY ROUGES; EYE CREAM; EYE GELS; EYE LINER; EYE LOTIONS; EYE MAKE-UP; EYE MAKE-UP REMOVER; EYE PENCILS; EYE SHADOW; EYE SHADOWS; EYE-SHADOW; EYES MAKE-UP; FACIAL CLEANSERS; FACIAL MAKE-UP; FOAM CLEANSERS FOR PERSONAL USE; FOUNDATION MAKE-UP; LIP BALM; LIP BALM; LIP CREAM; LIP GLOSS; LIP GLOSS PALATTE; LIP LINER; LIP POLISHER; LIPSTICK; LIPSTICKS; MAKE UP FOUNDATIONS; MAKE UP REMOVING PREPARATIONS; MAKE-UP; MAKE-UP FOR THE FACE AND BODY; MAKE-UP FOUNDATIONS; MAKE-UP PENCILS; MAKE-UP POWDER; MAKE-UP PREPARATIONS; MAKE-UP PREPARATIONS FOR THE FACE AND BODY; MAKE-UP REMOVER; MAKE-UP REMOVING LOTIONS; MAKE-UP REMOVING MILK, GEL, LOTIONS AND CREAMS; MAKE-UP REMOVING MILKS; MAKE-UP REMOVING PREPARATIONS; MOISTURIZING CREAMS; MOISTURIZING MILKS; NON-MEDICATED LIP CARE PREPARATIONS; ROUGE; ROUGES; SKIN CLEANSERS; SKIN MOISTURIZER; SKIN MOISTURIZER MASKS (U.S. CLS. 1, 4, 6, 50, 51 AND 52).

FIRST USE 8-1-2010; IN COMMERCE 9-10-2010.

3,941,892. L'OREAL USA CREATIVE, INC., NEW YORK, NY. SN 77-933,276. PUB. 4-20-2010, FILED 2-11-2010.

**NIACIN-E**

THE MARK CONSISTS OF STANDARD CHARACTERS WITHOUT CLAIM TO ANY PARTICULAR FONT, STYLE, SIZE, OR COLOR.

NO CLAIM IS MADE TO THE EXCLUSIVE RIGHT TO USE "NIACIN", APART FROM THE MARK AS SHOWN.

FOR A COMBINATION OF INGREDIENTS SOLD AS AN INTEGRAL COMPONENT OF HAIR CARE PREPARATIONS (U.S. CLS. 1, 4, 6, 50, 51 AND 52).

FIRST USE 1-0-2011; IN COMMERCE 1-0-2011.

**CLASS 3—(Continued).**

3,941,905. LEVI, GENO R., BETHEL PARK, PA. AND LEVI, CYNTHIA N., BETHEL PARK, PA. SN 77-936,784. PUB. 6-29-2010, FILED 2-16-2010.

**PH RENEWAL**

THE MARK CONSISTS OF STANDARD CHARACTERS WITHOUT CLAIM TO ANY PARTICULAR FONT, STYLE, SIZE, OR COLOR.

NO CLAIM IS MADE TO THE EXCLUSIVE RIGHT TO USE "PH", APART FROM THE MARK AS SHOWN.

FOR HAIR CARE PREPARATIONS (U.S. CLS. 1, 4, 6, 50, 51 AND 52).

FIRST USE 11-2-2010; IN COMMERCE 12-28-2010.

---

3,941,915. POLA CHEMICAL INDUSTRIES INC., SHIZUOKA-KEN, JAPAN. SN 77-941,074. PUB. 7-20-2010, FILED 2-22-2010.

**EVANGILE**

THE MARK CONSISTS OF STANDARD CHARACTERS WITHOUT CLAIM TO ANY PARTICULAR FONT, STYLE, SIZE, OR COLOR.

FOR COSMETICS; SKIN LOTIONS; COSMETIC CREAMS; SOAPS; NON-MEDICATED SKIN CARE PREPARATIONS; SKIN MOISTURIZER MASKS (U.S. CLS. 1, 4, 6, 50, 51 AND 52).

FIRST USE 11-1-1978; IN COMMERCE 11-1-1979.

---

3,941,917. POLA CHEMICAL INDUSTRIES INC., SHIZUOKA-KEN, JAPAN. SN 77-941,190. PUB. 7-20-2010, FILED 2-22-2010.

**POLISSIMA**

THE MARK CONSISTS OF STANDARD CHARACTERS WITHOUT CLAIM TO ANY PARTICULAR FONT, STYLE, SIZE, OR COLOR.

FOR COSMETICS; SKIN LOTIONS; COSMETIC CREAMS; SOAPS; NON-MEDICATED SKIN CARE PREPARATIONS; SKIN MOISTURIZER MASKS (U.S. CLS. 1, 4, 6, 50, 51 AND 52).

FIRST USE 10-1-1972; IN COMMERCE 10-1-1973.

**CLASS 3—(Continued).**

3,941,939. PICKETT, ADRIENE, LOS ANGELES, CA. SN 77-946,771. PUB. 7-13-2010, FILED 2-28-2010.

**WE CREATE FOR YOU**

THE MARK CONSISTS OF STANDARD CHARACTERS WITHOUT CLAIM TO ANY PARTICULAR FONT, STYLE, SIZE, OR COLOR.

FOR COSMETIC CREAMS FOR SKIN CARE; COSMETIC OILS; COSMETIC PREPARATIONS FOR BODY CARE; COSMETIC PREPARATIONS FOR THE HAIR AND SCALP; SKIN AND BODY TOPICAL LOTIONS, CREAMS AND OILS FOR COSMETIC USE (U.S. CLS. 1, 4, 6, 50, 51 AND 52).

FIRST USE 12-1-2010; IN COMMERCE 12-1-2010.

---

3,941,982. M3 COSMETIC LABS LLC, HOLLY HILL, FL. SN 77-961,522. PUB. 8-24-2010, FILED 3-17-2010.

**ARGANICS**

THE MARK CONSISTS OF STANDARD CHARACTERS WITHOUT CLAIM TO ANY PARTICULAR FONT, STYLE, SIZE, OR COLOR.

FOR HAIR RELAXING PREPARATIONS; HAIR SHAMPOOS AND CONDITIONERS; HAIR SPRAYS AND HAIR GELS; HAIR STYLING PREPARATIONS (U.S. CLS. 1, 4, 6, 50, 51 AND 52).

FIRST USE 11-15-2010; IN COMMERCE 11-15-2010.

---

3,941,985. PROCTER & GAMBLE COMPANY, CINCINNATI, OH. SN 77-963,635. PUB. 8-10-2010, FILED 3-19-2010.

**FRESH EFFECTS**

THE MARK CONSISTS OF STANDARD CHARACTERS WITHOUT CLAIM TO ANY PARTICULAR FONT, STYLE, SIZE, OR COLOR.

OWNER OF U.S. REG. NO. 3,661,951.  
FOR BODY SPRAYS (U.S. CLS. 1, 4, 6, 50, 51 AND 52).

FIRST USE 7-5-2010; IN COMMERCE 7-5-2010.

**CLASS 3—(Continued).**

3,942,004. YBF LLC, NEW YORK, NY. SN 77-979,062. PUB. 6-10-2008, FILED 2-14-2008.



THE MARK CONSISTS OF "FOUR HEARTS INTER-TWINED".  
FOR COSMETICS, NON-MEDICATED SKIN CARE PREPARATIONS (U.S. CLS. 1, 4, 6, 50, 51 AND 52).  
FIRST USE 6-19-2008; IN COMMERCE 6-19-2008.

3,942,040. THE PROCTER & GAMBLE COMPANY, CINCINNATI, OH. SN 77-981,404. PUB. 6-8-2010, FILED 7-15-2008.

**CELLUMINATION**

THE MARK CONSISTS OF STANDARD CHARACTERS WITHOUT CLAIM TO ANY PARTICULAR FONT, STYLE, SIZE, OR COLOR.

FOR NON-MEDICATED SKIN CARE PREPARATIONS; SKIN WHITENING PREPARATIONS; COSMETICS (U.S. CLS. 1, 4, 6, 50, 51 AND 52).  
FIRST USE 2-1-2010; IN COMMERCE 2-1-2010.

3,942,067. TRISH MCEVOY LTD., NEW YORK, NY. SN 78-918,595. PUB. 8-28-2007, FILED 6-28-2006.

**Normal To Oily Skin Days**

THE MARK CONSISTS OF STANDARD CHARACTERS WITHOUT CLAIM TO ANY PARTICULAR FONT, STYLE, SIZE, OR COLOR.  
OWNER OF U.S. REG. NOS. 3,165,549, 3,174,433, AND 3,174,440.

**CLASS 3—(Continued).**

NO CLAIM IS MADE TO THE EXCLUSIVE RIGHT TO USE "NORMAL TO OILY SKIN", APART FROM THE MARK AS SHOWN.

FOR COSMETIC PRODUCTS, NAMELY, SKIN CREAMS AND LOTIONS (U.S. CLS. 1, 4, 6, 50, 51 AND 52).

FIRST USE 10-0-2009; IN COMMERCE 10-0-2009.

3,942,100. CIANCI, DEBRA L, DBA HAIR DETAILERS, PALM HARBOR, FL. SN 85-011,743. PUB. 9-7-2010, FILED 4-12-2010.

**Hair Detailers**

THE MARK CONSISTS OF STANDARD CHARACTERS WITHOUT CLAIM TO ANY PARTICULAR FONT, STYLE, SIZE, OR COLOR.

NO CLAIM IS MADE TO THE EXCLUSIVE RIGHT TO USE "HAIR", APART FROM THE MARK AS SHOWN.

FOR AROMATHERAPY BODY CARE PRODUCTS, NAMELY, BODY LOTION, SHOWER GEL, CUTICLE CREAM, SHAMPOO, CONDITIONER, NON-MEDICATED LIP BALM, SOAP, BODY POLISH, BODY AND FOOT SCRUB AND NON-MEDICATED FOOT CREAM (U.S. CLS. 1, 4, 6, 50, 51 AND 52).

FIRST USE 1-31-2011; IN COMMERCE 1-31-2011.

3,942,188. THE DIAL CORPORATION, SCOTTSDALE, AZ. SN 85-047,549. PUB. 11-2-2010, FILED 5-25-2010.

**RIGHT GUARD TOTAL DEFENSE**

THE MARK CONSISTS OF STANDARD CHARACTERS WITHOUT CLAIM TO ANY PARTICULAR FONT, STYLE, SIZE, OR COLOR.

OWNER OF U.S. REG. NOS. 692,546, 3,794,195, AND OTHERS.

FOR BATH SOAPS; LIQUID SOAP FOR BODY; LIQUID SOAPS (U.S. CLS. 1, 4, 6, 50, 51 AND 52).

FIRST USE 12-15-2010; IN COMMERCE 12-15-2010.

**CLASS 3—(Continued).**

3,942,192. FARAH, SHEILA, SAO PAULO, BRAZIL. AND PORTO BELLO COM. EXP. PRODUTOS DE HIGIENE LTDA., SAO PAULO, BRAZIL. SN 85-048,652. PUB. 11-2-2010, FILED 5-26-2010.

---

**amazon secrets**

THE MARK CONSISTS OF STANDARD CHARACTERS WITHOUT CLAIM TO ANY PARTICULAR FONT, STYLE, SIZE, OR COLOR.

NO CLAIM IS MADE TO THE EXCLUSIVE RIGHT TO USE "AMAZON", APART FROM THE MARK AS SHOWN.

FOR AFTER SUN CREAMS; AFTER-SHAVE CREAMS; AROMATIC BODY CARE PRODUCTS, NAMELY, BODY LOTION, SHOWER GEL, CUTICLE CREAM, SHAMPOO, CONDITIONER, NON-MEDICATED LIP BALM, SOAP, BODY POLISH, BODY AND FOOT SCRUB AND NON-MEDICATED FOOT CREAM; BATH SOAPS IN LIQUID, SOLID OR GEL FORM; COSMETIC CREAMS FOR SKIN CARE; EXFOLIANT CREAMS; NON-MEDICATED SUN CARE PREPARATIONS; SKIN MOISTURIZER (U.S. CLS. 1, 4, 6, 50, 51 AND 52).

FIRST USE 9-20-2010; IN COMMERCE 9-20-2010.

---

3,942,216. POOCH ENTERPRISES, LLC, MIAMI, FL. SN 85-053,764. PUB. 11-9-2010, FILED 6-3-2010.

**Pure Pooch**

THE MARK CONSISTS OF STANDARD CHARACTERS WITHOUT CLAIM TO ANY PARTICULAR FONT, STYLE, SIZE, OR COLOR.

FOR DEODORIZERS FOR PETS; NON-MEDICATED GROOMING PREPARATIONS FOR DOGS, NAMELY, SHAMPOOS, CONDITIONERS, AND DETANGLING SPRAYS; PET SHAMPOO; PET SHAMPOO AND CONDITIONER (U.S. CLS. 1, 4, 6, 50, 51 AND 52).

FIRST USE 11-23-2010; IN COMMERCE 11-23-2010.

---

3,942,225. LAURA GELLER MAKE-UP STUDIOS, LTD, NEW YORK, NY. SN 85-054,608. PUB. 11-2-2010, FILED 6-4-2010.

**REAL DEAL REMEDY STICK**

THE MARK CONSISTS OF STANDARD CHARACTERS WITHOUT CLAIM TO ANY PARTICULAR FONT, STYLE, SIZE, OR COLOR.

**CLASS 3—(Continued).**

NO CLAIM IS MADE TO THE EXCLUSIVE RIGHT TO USE "REMEDY STICK", APART FROM THE MARK AS SHOWN. FOR MAKEUP PRIMER (U.S. CLS. 1, 4, 6, 50, 51 AND 52).

FIRST USE 12-13-2010; IN COMMERCE 12-13-2010.

---

3,942,226. SOL ROSA LLC, BENZONIA, MI. SN 85-054,687. PUB. 11-2-2010, FILED 6-4-2010.

**IZLLA**

THE MARK CONSISTS OF STANDARD CHARACTERS WITHOUT CLAIM TO ANY PARTICULAR FONT, STYLE, SIZE, OR COLOR.

FOR BATH SALTS; FACIAL CLEANSERS; LIP BALM; NON-MEDICATED SKIN CARE CREAMS AND LOTIONS; NON-MEDICATED SKIN CARE PREPARATION, NAMELY, BODY MIST (U.S. CLS. 1, 4, 6, 50, 51 AND 52).

FIRST USE 6-1-2010; IN COMMERCE 6-1-2010.

---

3,942,231. CHRISTAL, DEAN V., SANTA BARBARA, CA. SN 85-056,692. PUB. 11-9-2010, FILED 6-7-2010.

**California Smooth**

THE MARK CONSISTS OF STANDARD CHARACTERS WITHOUT CLAIM TO ANY PARTICULAR FONT, STYLE, SIZE, OR COLOR.

NO CLAIM IS MADE TO THE EXCLUSIVE RIGHT TO USE "CALIFORNIA", APART FROM THE MARK AS SHOWN.

FOR HAIR CARE PREPARATIONS; HAIR RELAXING PREPARATIONS; HAIR SHAMPOOS AND CONDITIONERS; HAIR STYLING PREPARATIONS; STYLING LOTIONS (U.S. CLS. 1, 4, 6, 50, 51 AND 52).

FIRST USE 12-27-2010; IN COMMERCE 12-27-2010.

**CLASS 3—(Continued).**

3,942,251. ZYZY INC, MIAMI, FL. SN 85-065,032. PUB. 11-16-2010, FILED 6-17-2010.

satyros

THE MARK CONSISTS OF STANDARD CHARACTERS WITHOUT CLAIM TO ANY PARTICULAR FONT, STYLE, SIZE, OR COLOR.

FOR COLOGNES, PERFUMES AND COSMETICS; PERFUMES AND TOILET WATERS; PERFUMES, EAU DE COLOGNES AND AFTERSHAVES (U.S. CLS. 1, 4, 6, 50, 51 AND 52).

FIRST USE 6-25-2009; IN COMMERCE 6-25-2009.

3,942,263. CHURCH & DWIGHT CO., INC., PRINCETON, NJ. SN 85-068,613. PUB. 10-12-2010, FILED 6-22-2010.

FRESH SCENTSATIONS

THE MARK CONSISTS OF STANDARD CHARACTERS WITHOUT CLAIM TO ANY PARTICULAR FONT, STYLE, SIZE, OR COLOR.

OWNER OF U.S. REG. NOS. 3,304,415 AND 3,797,341. FOR LAUNDRY DETERGENT (U.S. CLS. 1, 4, 6, 50, 51 AND 52).

FIRST USE 8-15-2010; IN COMMERCE 8-15-2010.

3,942,273. URBAN DECAY COSMETICS LLC, NEWPORT BEACH, CA. SN 85-071,859. PUB. 11-30-2010, FILED 6-25-2010.

URBAN LASH

THE MARK CONSISTS OF STANDARD CHARACTERS WITHOUT CLAIM TO ANY PARTICULAR FONT, STYLE, SIZE, OR COLOR.

OWNER OF U.S. REG. NOS. 2,056,875, 3,692,348, AND OTHERS.

NO CLAIM IS MADE TO THE EXCLUSIVE RIGHT TO USE "LASH", APART FROM THE MARK AS SHOWN.

FOR COSMETICS (U.S. CLS. 1, 4, 6, 50, 51 AND 52). FIRST USE 7-12-2010; IN COMMERCE 7-12-2010.

**CLASS 3—(Continued).**

3,942,325. ABERCROMBIE & FITCH TRADING CO., NEW ALBANY, OH. SN 85-975,073. PUB. 10-12-2010, FILED 5-14-2010.

SADIE

THE MARK CONSISTS OF STANDARD CHARACTERS WITHOUT CLAIM TO ANY PARTICULAR FONT, STYLE, SIZE, OR COLOR.

FOR FRAGRANCES FOR PERSONAL USE; PERFUME (U.S. CLS. 1, 4, 6, 50, 51 AND 52).

FIRST USE 10-30-2010; IN COMMERCE 10-30-2010.

**CLASS 4—LUBRICANTS AND FUELS**

3,941,047. WESTERN GAS PARTNERS, LP, THE WOODLANDS, TX. SN 77-295,248. PUB. 5-13-2008, FILED 10-3-2007.



THE COLOR(S) BLUE AND BLACK IS/ARE CLAIMED AS A FEATURE OF THE MARK.

THE COLOR BLACK APPEARS IN THE OUTER CIRCLE AND THE OUTER PART OF THE LETTER "W"; THE COLOR BLUE APPEARS IN THE INNER CIRCLE AND THE INNER PART OF THE LETTER "W".

FOR LUBRICANTS AND FUELS, NAMELY, OIL, NATURAL GAS AND LIQUID NATURAL GAS; AND INDUSTRIAL OILS AND GREASES (U.S. CLS. 1, 6 AND 15).

FIRST USE 7-22-2009; IN COMMERCE 7-22-2009.



**CLASS 4—(Continued).**

3,941,721. SMITH MOUNTAIN INDUSTRIES, INC., FOREST, VA. SN 77-905,113. PUB. 5-18-2010, FILED 1-5-2010.

# FALL HARVEST

THE MARK CONSISTS OF STANDARD CHARACTERS WITHOUT CLAIM TO ANY PARTICULAR FONT, STYLE, SIZE, OR COLOR.  
FOR CANDLES (U.S. CLS. 1, 6 AND 15).  
FIRST USE 7-0-2009; IN COMMERCE 7-0-2009.

---

**CLASS 5—PHARMACEUTICALS**

3,941,041. ISATORI TECHNOLOGIES, LLC, GOLDEN, CO. SN 77-241,161. PUB. 11-23-2010, FILED 7-27-2007.

# MORPH

THIS MARK CONSISTS OF THE WORD "MORPH" PRESENTED IN STYLIZED FONT.  
FOR PHARMACEUTICALS, NAMELY, NUTRITIONAL SUPPLEMENTS IN THE FORM OF FORMULAS, POWDERS AND TABLETS (U.S. CLS. 6, 18, 44, 46, 51 AND 52).  
FIRST USE 7-1-2007; IN COMMERCE 9-20-2007.

---

3,941,071. DOW AGROSCIENCES LLC, INDIANAPOLIS, IN. SN 77-426,875. PUB. 12-16-2008, FILED 3-20-2008.

# PINDAR

THE MARK CONSISTS OF STANDARD CHARACTERS WITHOUT CLAIM TO ANY PARTICULAR FONT, STYLE, SIZE, OR COLOR.  
FOR PESTICIDES AND PREPARATIONS FOR DESTROYING VERMIN, NAMELY, HERBICIDES FOR AGRICULTURE, HORTICULTURE, FORESTRY, TURF AND ORNAMENTAL, AND COMMERCIAL USE (U.S. CLS. 6, 18, 44, 46, 51 AND 52).  
FIRST USE 9-3-2010; IN COMMERCE 9-3-2010.

**CLASS 5—(Continued).**

3,941,075. ATM METABOLICS LLLP, WINTER HAVEN, FL. SN 77-430,365. PUB. 6-17-2008, FILED 3-25-2008.

# EMULIN

THE MARK CONSISTS OF STANDARD CHARACTERS WITHOUT CLAIM TO ANY PARTICULAR FONT, STYLE, SIZE, OR COLOR.  
FOR DIETARY AND NUTRITIONAL SUPPLEMENTS FOR WEIGHT LOSS; DIETETIC FOODSTUFFS AND NUTRITIONAL ADDITIVES FOR MEDICAL PURPOSES FOR USE IN FOODS AND DIETARY SUPPLEMENTS FOR HUMAN AND ANIMAL CONSUMPTION; FOODS FOR MEDICALLY RESTRICTED DIETS, DIETARY SUPPLEMENTAL DRINKS (U.S. CLS. 6, 18, 44, 46, 51 AND 52).  
FIRST USE 12-10-2010; IN COMMERCE 12-10-2010.

---

3,941,096. FAR EAST IMPORTING AND EXPORTING COMPANY, PORTLAND, OR. SN 77-502,495. PUB. 5-11-2010, FILED 6-19-2008.

# SCIENTIFIC LAB OF NATURAL HERBS AND SUPPLEMENTS

THE MARK CONSISTS OF STANDARD CHARACTERS WITHOUT CLAIM TO ANY PARTICULAR FONT, STYLE, SIZE, OR COLOR.  
NO CLAIM IS MADE TO THE EXCLUSIVE RIGHT TO USE "LAB OF NATURAL HERBS AND SUPPLEMENTS", APART FROM THE MARK AS SHOWN.  
FOR DIETARY AND NUTRITIONAL SUPPLEMENTS; DIETARY SUPPLEMENTS; HERBAL SUPPLEMENTS; HERBAL TOPICAL CREAMS, GELS, SALVES, SPRAYS, POWDER, BALMS, LINIMENT AND OINTMENTS FOR THE RELIEF OF ACHE AND PAIN; MINERAL NUTRITIONAL SUPPLEMENTS; MINERAL SUPPLEMENTS; NATURAL HERBAL SUPPLEMENTS; NUTRITIONAL SUPPLEMENTS; PROTEIN SUPPLEMENTS; VITAMIN AND MINERAL SUPPLEMENTS; VITAMIN SUPPLEMENTS (U.S. CLS. 6, 18, 44, 46, 51 AND 52).  
FIRST USE 11-0-2010; IN COMMERCE 11-0-2010.

---

3,941,124. NURTURED PETS, LLC, NEW PHILADELPHIA, OH. SN 77-553,609. PUB. 4-7-2009, FILED 8-22-2008.

# ANTI-LICK STRIP PRO C

THE MARK CONSISTS OF STANDARD CHARACTERS WITHOUT CLAIM TO ANY PARTICULAR FONT, STYLE, SIZE, OR COLOR.

**CLASS 5—(Continued).**

NO CLAIM IS MADE TO THE EXCLUSIVE RIGHT TO USE "PRO", APART FROM THE MARK AS SHOWN.

FOR VETERINARY MEDICAL AND ANIMAL HEALTH APPARATUS, NAMELY, BANDAGES FOR SKIN WOUNDS THAT MAY BE CONNECTED TO AN ANIMAL TO DETER AN ANIMAL FROM AGGRAVATING AN INJURY OR WOUND BY LICKING OR CHEWING ON THE INJURY OR WOUND (U.S. CLS. 6, 18, 44, 46, 51 AND 52).

FIRST USE 10-31-2010; IN COMMERCE 10-31-2010.

---

3,941,139. NUGEN TECHNOLOGIES, INC., SAN CARLOS, CA. SN 77-580,362. PUB. 5-12-2009, FILED 9-26-2008.

# OVATION

THE MARK CONSISTS OF STANDARD CHARACTERS WITHOUT CLAIM TO ANY PARTICULAR FONT, STYLE, SIZE, OR COLOR.

OWNER OF U.S. REG. NO. 3,099,464.

FOR CHEMICALS, CHEMICAL ASSAYS, REAGENTS FOR THE ANALYSIS OF NUCLEIC ACIDS, PROTEINS AND ANTIBODIES, NUCLEIC ACID SEQUENCE AMPLIFICATION, SEQUENCING AND SEQUENCE ANALYSIS AND DETECTION, OLIGONUCLEOTIDES, AND CDNA AND RNA LIBRARIES AND MICROARRAYS, ALL FOR CLINICAL MEDICAL USE (U.S. CLS. 6, 18, 44, 46, 51 AND 52).

FIRST USE 2-18-2008; IN COMMERCE 2-18-2008.

---

3,941,171. BLACKSMITH BRANDS, INC., IRVINGTON, NY. SN 77-626,351. PUB. 4-14-2009, FILED 12-4-2008.

# TRUSTED LUDEN'S CARE

THE MARK CONSISTS OF STANDARD CHARACTERS WITHOUT CLAIM TO ANY PARTICULAR FONT, STYLE, SIZE, OR COLOR.

OWNER OF U.S. REG. NOS. 1,599,161, 1,811,404, AND 2,890,089.

FOR COUGH AND THROAT DROPS (U.S. CLS. 6, 18, 44, 46, 51 AND 52).

FIRST USE 2-1-2002; IN COMMERCE 2-1-2002.

**CLASS 5—(Continued).**

3,941,204. BISSELL HOMECARE, INC., GRAND RAPIDS, MI. SN 77-655,230. PUB. 5-5-2009, FILED 1-23-2009.

# PEW!

THE MARK CONSISTS OF STANDARD CHARACTERS WITHOUT CLAIM TO ANY PARTICULAR FONT, STYLE, SIZE, OR COLOR.

FOR AIR FRESHENERS AND ODOR ELIMINATORS (U.S. CLS. 6, 18, 44, 46, 51 AND 52).

FIRST USE 7-6-2010; IN COMMERCE 7-6-2010.

---

3,941,225. ASTRAZENECA UK LIMITED, LONDON, UNITED KINGDOM. SN 77-670,350. PUB. 6-9-2009, FILED 2-13-2009.

# VIMOVO

THE MARK CONSISTS OF STANDARD CHARACTERS WITHOUT CLAIM TO ANY PARTICULAR FONT, STYLE, SIZE, OR COLOR.

OWNER OF U.S. REG. NO. 2,629,729.

THE WORDING "VIMOVO" HAS NO MEANING IN A FOREIGN LANGUAGE.

FOR PHARMACEUTICAL PREPARATIONS AND SUBSTANCES FOR THE TREATMENT OF PAIN AND INFLAMMATION (U.S. CLS. 6, 18, 44, 46, 51 AND 52).

FIRST USE 8-6-2010; IN COMMERCE 8-6-2010.

---

3,941,318. BLOCK DRUG COMPANY, INC., WEST TRENTON, NJ. SN 77-764,173. PUB. 9-29-2009, FILED 6-19-2009.

# MELTAWAYS

THE MARK CONSISTS OF STANDARD CHARACTERS WITHOUT CLAIM TO ANY PARTICULAR FONT, STYLE, SIZE, OR COLOR.

FOR DIETARY AID, NAMELY, AN ENZYME TO ELIMINATE OR REDUCE GAS (U.S. CLS. 6, 18, 44, 46, 51 AND 52).

FIRST USE 3-31-2010; IN COMMERCE 3-31-2010.

**CLASS 5—(Continued).**

3,941,327. L. PERRIGO COMPANY, ALLEGAN, MI. SN 77-767,822. PUB. 6-8-2010, FILED 6-25-2009.



NO CLAIM IS MADE TO THE EXCLUSIVE RIGHT TO USE BOTH OCCURRENCES OF "GLUTEN FREE", APART FROM THE MARK AS SHOWN.

THE MARK CONSISTS OF A SEAL DESIGN WITH A MICROSCOPE IN A CIRCLE IN THE CENTER WITH "GLUTEN FREE" ABOVE AND BELOW THE MICROSCOPE.

FOR ANTACIDS; ANTIEMETICS; PHARMACEUTICAL PREPARATIONS TO AID DIGESTION, NAMELY, ANTI-GAS PREPARATIONS; ANTIHISTAMINES; PHARMACEUTICAL PREPARATIONS FOR TREATING COUGH, COLD, ALLERGY AND FLU SYMPTOMS; COUGH SYRUPS; DECONGESTANT LIQUIDS AND CAPSULES; DECONGESTANT NASAL SPRAYS; DIARRHEA MEDICATIONS; DIETARY SUPPLEMENTS; EXPECTORANTS; LAXATIVES; LIQUID PHARMACEUTICAL PREPARATIONS FOR THE TREATMENT OF HEARTBURN, NAUSEA, AND DIARRHEA; MOTION SICKNESS TREATMENT PREPARATIONS; PHARMACEUTICAL PREPARATIONS, NAMELY, NON-ASPIRIN SINUS PREPARATIONS FOR THE TREATMENT OF SINUS HEADACHE, CONGESTION AND PRESSURE; NOSE DROPS; ORAL ANALGESICS; ORAL ELECTROLYTE SOLUTIONS; PAIN RELIEF MEDICATIONS; SLEEP AID PILLS AND TABLETS; SMOKING CESSATION PREPARATIONS; AND GASTROINTESTINAL CLEANING AGENTS, NAMELY, STOOL SOFTENERS. ALL THE AFOREMENTIONED GOODS ARE GLUTEN FREE (U.S. CLS. 6, 18, 44, 46, 51 AND 52).

FIRST USE 12-28-2010; IN COMMERCE 12-28-2010.

3,941,328. MORGAN MADISON, LLC, ORANGE, CA. SN 77-768,623. PUB. 6-15-2010, FILED 6-25-2009.

**HEALTH TOUCH SOLUTIONS**

THE MARK CONSISTS OF STANDARD CHARACTERS WITHOUT CLAIM TO ANY PARTICULAR FONT, STYLE, SIZE, OR COLOR.

NO CLAIM IS MADE TO THE EXCLUSIVE RIGHT TO USE "HEALTH", APART FROM THE MARK AS SHOWN.

FOR DISPOSABLE PLASTIC STRIPS TREATED WITH AN ANTI-MICROBIAL ACTIVE INGREDIENT TO SURROUND A HANDLE (U.S. CLS. 6, 18, 44, 46, 51 AND 52). FIRST USE 4-25-2010; IN COMMERCE 8-16-2010.

**CLASS 5—(Continued).**

3,941,329. PURITY PRODUCTS, INC., PLAINVIEW, NY. SN 77-768,642. PUB. 5-25-2010, FILED 6-25-2009.

**FLUID FOCUS**

THE MARK CONSISTS OF STANDARD CHARACTERS WITHOUT CLAIM TO ANY PARTICULAR FONT, STYLE, SIZE, OR COLOR.

NO CLAIM IS MADE TO THE EXCLUSIVE RIGHT TO USE "FLUID", APART FROM THE MARK AS SHOWN.

FOR DIETARY AND NUTRITIONAL SUPPLEMENTS, FOOD SUPPLEMENTS, NUTRITIONAL SUPPLEMENTS, VITAMIN SUPPLEMENTS, BRAIN SUPPORT SUPPLEMENTS, NUTRACEUTICALS FOR USE AS A DIETARY SUPPLEMENT (U.S. CLS. 6, 18, 44, 46, 51 AND 52).

FIRST USE 9-13-2009; IN COMMERCE 9-13-2009.

3,941,377. MAXILL INC., DBA MAXILL, ST. THOMAS, ONTARIO, CANADA. SN 77-785,918. PUB. 12-29-2009, FILED 7-21-2009.



NO CLAIM IS MADE TO THE EXCLUSIVE RIGHT TO USE "FAST ACTING" "TB" "BACTERICIDAL/TUBERCULOCIDAL/VIRUCIDAL" AND "HARD SURFACE DISINFECTANT", APART FROM THE MARK AS SHOWN.

THE MARK CONSISTS OF AN ICON OF A CLOCK TO THE LEFT OF AND PARTIALLY OBSCURED BY THE LETTERS "TB"; TO THE RIGHT OF "TB" ARE THE WORDS "FAST ACTING" AND IMMEDIATELY BELOW IS AN ICON OF A LIGHTNING BOLT; BELOW THE LIGHTNING BOLT APPEAR THE WORDS "BACTERICIDAL/TUBERCULOCIDAL/VIRUCIDAL" IN SMALL FONT; AND BELOW THOSE WORDS IN LARGER FONT AND IN A BOX IS THE WORD "MINUTEMAN", WITH THE BOX CONTAINING THAT WORD BEING UNDERLINED; AND BELOW THE WORD "MINUTEMAN" AND TO THE RIGHT OF "TB" ARE THE WORDS, IN MUCH SMALLER FONT, "HARD SURFACE DISINFECTANT".

FOR DISINFECTANTS FOR HYGIENE PURPOSES (U.S. CLS. 6, 18, 44, 46, 51 AND 52).

FIRST USE 1-24-2011; IN COMMERCE 1-24-2011.

**CLASS 5—(Continued).**

3,941,385. YUNG SHIN PHARM. IND. CO., LTD., TACHIA TAICHUNG, TAIWAN. SN 77-790,302. PUB. 6-22-2010, FILED 7-27-2009.

漢鼎

THE MARK CONSISTS OF CHINESE CHARACTERS. THE NON-LATIN CHARACTERS IN THE MARK TRANSLITERATE TO HAN DEAN AND "HAN" MEANS "CHINESE PEOPLE OR LANGUAGE" IN ENGLISH AND "DEAN" MEANS "A THREE-LEGGED ANCIENT CHINESE COOKING VESSEL" IN ENGLISH.

FOR MEDICINAL HERBS; FOUR SUBSTANCE DECOCTION PILLS FOR MEDICINAL PURPOSES; LOQUAT SYRUP FOR MEDICINAL PURPOSES; TRANSDERMAL PATCHES FOR PAIN RELIEF; MOXA STICKS FOR MEDICINAL PURPOSES, NAMELY, MOXIBUSTION; MEDICINAL ALCOHOLIC BEVERAGES FOR PAIN RELIEF; PHARMACEUTICAL PREPARATIONS IN THE FORM OF KNEAD FOR PAIN RELIEF; GINSENG FOR MEDICINAL USE; FEVER RELIEF TABLET AND PILLS; MENSTRUAL SYMPTOM TREATMENT PREPARATIONS; PHARMACEUTICAL PREPARATIONS FOR THE PREVENTION AND TREATMENT OF KIDNEY DISEASES; PHARMACEUTICAL PREPARATIONS FOR FACILITATING BLOOD GENERATION; PHARMACEUTICAL PREPARATIONS FOR WEIGHT GAIN; DIET PILLS; PHARMACEUTICAL PREPARATIONS FOR THE TREATMENT OF ECZEMA; PHARMACEUTICAL PREPARATIONS FOR THE TREATMENT OF GOUT; PHARMACEUTICAL PREPARATIONS FOR THE TREATMENT OF ARTHRITIS; PHARMACEUTICAL PREPARATIONS FOR BOOSTING ENERGY; PHARMACEUTICAL PREPARATIONS FOR THE TREATMENT OF BURNS; ACNE TREATMENT PREPARATIONS; PHARMACEUTICAL ANTI-ALLERGIC PREPARATIONS AND SUBSTANCES; ANTIDEPRESSANTS; PHARMACEUTICAL PREPARATIONS FOR THE PREVENTION AND TREATMENT OF DISORDERS OF THE IMMUNE SYSTEM; PHARMACEUTICAL PREPARATIONS FOR TREATING DIABETES; CHOLESTEROL REDUCERS; HYPNOTICS; GASTRO-INTESTINAL TREATMENT PREPARATIONS; NUTRITIONAL SUPPLEMENTS FOR ELIMINATING TOXINS FROM THE LIVER; VITAMINS; VITAMIN PREPARATIONS; CALCIUM SUPPLEMENTS, NAMELY, CALCIUM POWDER; MULTIVITAMIN PREPARATIONS; HEPATOPROTECTIVE AGENTS FOR MEDICINAL PURPOSES, NAMELY, LIVER FUNCTION PROTECTIVE AGENT; TRANSDERMAL ANTI-INFLAMMATORY ANALGESIC ADHESIVE PATCHES FOR MEDICINAL PURPOSES; PHARMACEUTICAL PREPARATIONS IN THE FORM OF SOAK FOR PAIN RELIEF; VITAMIN SUP-

**CLASS 5—(Continued).**

PLEMENT IN TABLET FORM FOR USE IN MAKING AN EFFERVESCENT BEVERAGE WHEN ADDED TO WATER; MINERAL NUTRITIONAL SUPPLEMENTS; MINERAL FOOD SUPPLEMENTS; PROTEIN SUPPLEMENTS; NUTRITIONAL SUPPLEMENTS; PLANT FIBER NUTRITIONAL SUPPLEMENTS; FOOD SUPPLEMENTS, NAMELY, ANTI-OXIDANTS; DIETARY SUPPLEMENTS FOR MEDICAL USE CONTAINING LACTIC ACID BACTERIA; VITAMIN AND MINERAL SUPPLEMENTS; MEDICINAL DRINKS FOR MEDICAL USE, FOR USE IN BODY MAINTENANCE AND WEIGHT CONTROL; DIETETIC FOOD PRODUCTS FOR MEDICAL USE, FOR USE IN BODY MAINTENANCE AND WEIGHT CONTROL; TEAS FOR MEDICAL USE, FOR USE IN BODY MAINTENANCE AND WEIGHT CONTROL; LECITHIN FOR USE AS A DIETARY SUPPLEMENT; DIETARY AND NUTRITIONALLY FORTIFIED FOOD PRODUCTS ADAPTED FOR MEDICAL USE; DIETARY FIBER POWDER AS AN ADDITIVE FOR FOOD PRODUCTS FOR RESTRICTED DIET; FOOD FOR BABIES (U.S. CLS. 6, 18, 44, 46, 51 AND 52).

FIRST USE 8-9-2010; IN COMMERCE 8-9-2010.

3,941,414. D41E, LLC, JEFFERSONVILLE, IN. SN 77-801,623. PUB. 6-8-2010, FILED 8-11-2009.

*Komao*

THE MARK CONSISTS OF THE STYLIZED WORD "KOMAO". THE ENGLISH TRANSLATION OF "KOMAO" IN THE MARK IS "LONG HAIR". FOR HEALTH SUPPLEMENT, NAMELY, HAIR AND FINGERNAIL HEALTH FOOD SUPPLEMENTS (U.S. CLS. 6, 18, 44, 46, 51 AND 52).

FIRST USE 3-26-2010; IN COMMERCE 3-26-2010.

3,941,426. PREDICTIVE BIOSCIENCES, INC., LEXINGTON, MA. SN 77-805,016. PUB. 1-12-2010, FILED 8-14-2009.

CERTNDX

THE MARK CONSISTS OF STANDARD CHARACTERS WITHOUT CLAIM TO ANY PARTICULAR FONT, STYLE, SIZE, OR COLOR. FOR DIAGNOSTIC KITS CONSISTING PRIMARILY OF ASSAYS, REAGENTS AND BIOMARKERS FOR USE IN CANCER DIAGNOSIS (U.S. CLS. 6, 18, 44, 46, 51 AND 52).

FIRST USE 12-20-2010; IN COMMERCE 12-20-2010.

**CLASS 5—(Continued).**

3,941,451. RZN NUTRACEUTICALS, INC., ORANGE PARK, FL. SN 77-820,055. PUB. 4-27-2010, FILED 9-3-2009.



THE COLOR(S) BLUE AND ORANGE IS/ARE CLAIMED AS A FEATURE OF THE MARK.

THE MARK CONSISTS OF THE BLUE WORD "HERBAZORB" WHEREBY THE LETTER "Z" IS JOINED BY A VERTICALLY ARCING ORANGE LINE AND TOPPED WITH AN ORANGE DOT, CREATING THE IMPRESSION OF A HUMAN FORM.

FOR DIETARY SUPPLEMENTS (U.S. CLS. 6, 18, 44, 46, 51 AND 52).

FIRST USE 1-8-2011; IN COMMERCE 1-8-2011.

**CLASS 5—(Continued).**

3,941,583. MARLYN NUTRACEUTICALS, INC., DBA NATURALLY VITAMINS, PHOENIX, AZ. SN 77-878,852. PUB. 4-20-2010, FILED 11-23-2009.

# FIZZLIM

THE MARK CONSISTS OF STANDARD CHARACTERS WITHOUT CLAIM TO ANY PARTICULAR FONT, STYLE, SIZE, OR COLOR.

FOR DIETARY SUPPLEMENTS; NUTRITIONAL SUPPLEMENTS; VITAMIN SUPPLEMENT IN TABLET FORM FOR USE IN MAKING AN EFFERVESCENT BEVERAGE WHEN ADDED TO WATER (U.S. CLS. 6, 18, 44, 46, 51 AND 52).

FIRST USE 12-14-2010; IN COMMERCE 12-14-2010.

3,941,453. BARRATT ALAN RICHARD, SOLIHULL, UNITED KINGDOM. SN 77-821,232. PUB. 2-2-2010, FILED 9-7-2009.

# THERMOGRENADÉ

THE MARK CONSISTS OF STANDARD CHARACTERS WITHOUT CLAIM TO ANY PARTICULAR FONT, STYLE, SIZE, OR COLOR.

FOR APPETITE SUPPRESSANTS; DIET CAPSULES; DIET PILLS (U.S. CLS. 6, 18, 44, 46, 51 AND 52).

FIRST USE 2-2-2010; IN COMMERCE 8-1-2010.

3,941,595. LABORATOIRES FORTE PHARMA S.A.M, MONACO, MONACO. SN 77-880,547. PUB. 6-1-2010, FILED 11-25-2009.

# FORTÉ PHARMA

THE MARK CONSISTS OF STANDARD CHARACTERS WITHOUT CLAIM TO ANY PARTICULAR FONT, STYLE, SIZE, OR COLOR.

NO CLAIM IS MADE TO THE EXCLUSIVE RIGHT TO USE "PHARMA", APART FROM THE MARK AS SHOWN.

FOR DIETARY SUPPLEMENTS (U.S. CLS. 6, 18, 44, 46, 51 AND 52).

FIRST USE 10-29-2010; IN COMMERCE 10-29-2010.

3,941,562. JOINT RESTORATION FOUNDATION, INC., CENTENNIAL, CO. SN 77-872,570. PUB. 4-20-2010, FILED 11-13-2009.

# JRF StimuBlast

THE MARK CONSISTS OF STANDARD CHARACTERS WITHOUT CLAIM TO ANY PARTICULAR FONT, STYLE, SIZE, OR COLOR.

OWNER OF U.S. REG. NO. 3,692,252.

FOR BONE COMPOSITIONS OF BIOLOGICAL MATERIALS FOR MEDICAL AND SURGICAL USE (U.S. CLS. 6, 18, 44, 46, 51 AND 52).

FIRST USE 10-14-2010; IN COMMERCE 10-14-2010.

3,941,617. A. C. GRACE COMPANY, INC., BIG SANDY, TX. SN 77-885,470. PUB. 6-15-2010, FILED 12-3-2009.

# UNIQUE OMEGA

THE MARK CONSISTS OF STANDARD CHARACTERS WITHOUT CLAIM TO ANY PARTICULAR FONT, STYLE, SIZE, OR COLOR.

OWNER OF U.S. REG. NO. 2,288,889.

NO CLAIM IS MADE TO THE EXCLUSIVE RIGHT TO USE "OMEGA", APART FROM THE MARK AS SHOWN.

FOR NUTRITIONAL SUPPLEMENTS CONTAINING OMEGA (U.S. CLS. 6, 18, 44, 46, 51 AND 52).

FIRST USE 1-25-2010; IN COMMERCE 1-25-2010.

**CLASS 5—(Continued).**

3,941,663. NUGEN TECHNOLOGIES, INC., SAN CARLOS, CA. SN 77-896,940. PUB. 5-18-2010, FILED 12-18-2009.

# NUGEN

THE MARK CONSISTS OF STANDARD CHARACTERS WITHOUT CLAIM TO ANY PARTICULAR FONT, STYLE, SIZE, OR COLOR.

OWNER OF U.S. REG. NOS. 2,882,764 AND 3,073,884.

FOR CHEMICALS, ASSAYS, REAGENTS AND KITS CONSISTING PRIMARILY OF CHEMICALS, ASSAYS, AND REAGENTS FOR THE ANALYSIS OF NUCLEIC ACIDS, PROTEINS AND ANTIBODIES FOR CLINICAL MEDICAL AND MEDICAL DIAGNOSTIC USE; CHEMICALS, ASSAYS, REAGENTS AND KITS CONSISTING PRIMARILY OF CHEMICALS, ASSAYS, AND REAGENTS FOR NUCLEIC ACID SEQUENCE AMPLIFICATION, SEQUENCING AND SEQUENCE ANALYSIS AND DETECTION, OLIGONUCLEOTIDES, CDNA AND RNA LIBRARIES AND MICROARRAYS FOR CLINICAL MEDICAL AND MEDICAL DIAGNOSTIC USE (U.S. CLS. 6, 18, 44, 46, 51 AND 52).

FIRST USE 1-31-2010; IN COMMERCE 1-31-2010.

3,941,728. POLYGIENE AB, MALMO, SWEDEN. SN 77-907,067. PUB. 5-25-2010, FILED 1-7-2010.



# Polygiene

THE MARK CONSISTS OF THE TERM "POLYGIENE" BENEATH THE FANCIFUL DESIGN OF A HUMAN HAND INSIDE A DARK CIRCLE WITH IRREGULAR EDGES.

FOR ANTI-MICROBIAL ADDITIVE FOR USE IN PRODUCTS MADE OF POLYMER MATERIALS; ANTI-MICROBIAL ADDITIVE FOR USE IN POST-TREATMENT OF TEXTILES (U.S. CLS. 6, 18, 44, 46, 51 AND 52).  
FIRST USE 1-15-2011; IN COMMERCE 1-15-2011.

**CLASS 5—(Continued).**

3,941,744. NUGEN TECHNOLOGIES, INC., SAN CARLOS, CA. SN 77-910,064. PUB. 5-18-2010, FILED 1-12-2010.

# RIBO-SPIA

THE MARK CONSISTS OF STANDARD CHARACTERS WITHOUT CLAIM TO ANY PARTICULAR FONT, STYLE, SIZE, OR COLOR.

OWNER OF U.S. REG. NOS. 3,077,855 AND 3,098,788.

FOR CHEMICALS, ASSAYS, REAGENTS AND KITS CONSISTING PRIMARILY OF CHEMICALS, ASSAYS, AND REAGENTS FOR THE ANALYSIS OF NUCLEIC ACIDS, PROTEINS AND ANTIBODIES FOR CLINICAL MEDICAL AND MEDICAL DIAGNOSTIC USE; CHEMICALS, ASSAYS, REAGENTS AND KITS CONSISTING PRIMARILY OF CHEMICALS, ASSAYS, AND REAGENTS FOR NUCLEIC ACID SEQUENCE AMPLIFICATION, SEQUENCING AND SEQUENCE ANALYSIS AND DETECTION, OLIGONUCLEOTIDES, CDNA AND RNA LIBRARIES AND MICROARRAYS FOR CLINICAL MEDICAL AND MEDICAL DIAGNOSTIC USE (U.S. CLS. 6, 18, 44, 46, 51 AND 52).

FIRST USE 1-31-2010; IN COMMERCE 1-31-2010.

3,941,750. PBM PRODUCTS, LLC, GORDONSVILLE, VA. SN 77-911,157. PUB. 6-1-2010, FILED 1-13-2010.

# GOOD NIGHT

THE MARK CONSISTS OF STANDARD CHARACTERS WITHOUT CLAIM TO ANY PARTICULAR FONT, STYLE, SIZE, OR COLOR.

FOR INFANT FORMULA (U.S. CLS. 6, 18, 44, 46, 51 AND 52).

FIRST USE 3-8-2010; IN COMMERCE 3-8-2010.

3,941,783. NAJIT TECHNOLOGIES, INC., PORTLAND, OR. SN 77-915,759. PUB. 6-8-2010, FILED 1-20-2010.

# HYDROVAX

THE MARK CONSISTS OF STANDARD CHARACTERS WITHOUT CLAIM TO ANY PARTICULAR FONT, STYLE, SIZE, OR COLOR.

FOR VACCINES FOR INFECTIOUS DISEASE (U.S. CLS. 6, 18, 44, 46, 51 AND 52).

FIRST USE 1-19-2011; IN COMMERCE 1-19-2011.

**CLASS 5—(Continued).**

3,941,808. SAUL SALAMANCA, DBA PROMESA DISTRIBUTORS, WINSTON SALEM, NC. SN 77-920,003. PUB. 6-8-2010, FILED 1-26-2010.

**PENTREXYL EXTRA**

THE MARK CONSISTS OF STANDARD CHARACTERS WITHOUT CLAIM TO ANY PARTICULAR FONT, STYLE, SIZE, OR COLOR.

FOR DIETARY AND NUTRITIONAL SUPPLEMENTS; VITAMIN SUPPLEMENTS; VITAMIN TABLETS (U.S. CLS. 6, 18, 44, 46, 51 AND 52).  
FIRST USE 6-25-2006; IN COMMERCE 4-10-2009.

3,941,822. INTERVET INC., ROSELAND, NJ. SN 77-921,144. PUB. 6-15-2010, FILED 1-27-2010.



THE COLOR(S) SILVER, WHITE AND GOLD IS/ARE CLAIMED AS A FEATURE OF THE MARK.

THE MARK CONSISTS OF THREE DROPS WITHIN EACH OTHER. THE OUTER DROP IS IN GOLD, THE MIDDLE DROP IS IN WHITE AND THE CENTER DROP IS IN SILVER.

FOR VETERINARY PREPARATIONS, NAMELY, DERMATOLOGICAL PREPARATIONS FOR VETERINARY USE (U.S. CLS. 6, 18, 44, 46, 51 AND 52).  
FIRST USE 9-15-2010; IN COMMERCE 9-15-2010.

3,941,835. FL FOOD LION, INC., SALISBURY, NC. SN 77-923,295. PUB. 6-1-2010, FILED 1-29-2010.

**HOME 360 BABY**

THE MARK CONSISTS OF STANDARD CHARACTERS WITHOUT CLAIM TO ANY PARTICULAR FONT, STYLE, SIZE, OR COLOR.

**CLASS 5—(Continued).**

OWNER OF U.S. REG. NO. 3,710,522.

NO CLAIM IS MADE TO THE EXCLUSIVE RIGHT TO USE "BABY", APART FROM THE MARK AS SHOWN.

FOR BABY FORMULA, BABY FOOD, BABY CEREAL AND TEETHING BISCUITS (U.S. CLS. 6, 18, 44, 46, 51 AND 52).

FIRST USE 9-0-2001; IN COMMERCE 9-0-2001.

3,941,840. NUTRI-HEALTH SUPPLEMENTS, LLC, COTTONWOOD, AZ. SN 77-924,952. PUB. 6-8-2010, FILED 2-1-2010.

**FOCUS FIRST**

THE MARK CONSISTS OF STANDARD CHARACTERS WITHOUT CLAIM TO ANY PARTICULAR FONT, STYLE, SIZE, OR COLOR.

FOR DIETARY AND NUTRITIONAL SUPPLEMENTS (U.S. CLS. 6, 18, 44, 46, 51 AND 52).

FIRST USE 3-12-2010; IN COMMERCE 4-16-2010.

3,941,841. NISUS CORPORATION, ROCKFORD, TN. SN 77-925,070. PUB. 10-5-2010, FILED 2-1-2010.

**SNAKEPROOF**

THE MARK CONSISTS OF STANDARD CHARACTERS WITHOUT CLAIM TO ANY PARTICULAR FONT, STYLE, SIZE, OR COLOR.

OWNER OF U.S. REG. NOS. 3,588,035 AND 3,713,360.  
NO CLAIM IS MADE TO THE EXCLUSIVE RIGHT TO USE "SNAKE", APART FROM THE MARK AS SHOWN.

FOR SNAKE REPELLENT (U.S. CLS. 6, 18, 44, 46, 51 AND 52).

FIRST USE 7-1-2010; IN COMMERCE 7-1-2010.

3,941,850. NUFARM AMERICAS INC., BURR RIDGE, IL. SN 77-926,118. PUB. 6-15-2010, FILED 2-2-2010.

**PROGENY**

THE MARK CONSISTS OF STANDARD CHARACTERS WITHOUT CLAIM TO ANY PARTICULAR FONT, STYLE, SIZE, OR COLOR.

FOR HERBICIDES; PESTICIDES (U.S. CLS. 6, 18, 44, 46, 51 AND 52).

FIRST USE 11-30-2010; IN COMMERCE 11-30-2010.

**CLASS 5—(Continued).**

3,941,865. IPSEN BIOPHARM LIMITED, WREXHAM, UNITED KINGDOM. SN 77-928,954. PUB. 6-22-2010, FILED 2-5-2010.



OWNER OF U.S. REG. NOS. 1,624,403, 3,759,924, AND OTHERS.

THE COLOR(S) BLACK AND BLUE IS/ARE CLAIMED AS A FEATURE OF THE MARK.

THE MARK CONSISTS OF THE FOLLOWING: THE WORDING "DYSPOORT" IN BLACK SUPERIMPOSED ON A FOUR LINE BLUE WAVE DESIGN.

FOR PHARMACEUTICAL PREPARATIONS CONTAINING BOTULINUM TOXIN, BOTULINUM TOXIN-HAEMAGGLUTIN COMPLEX, BOTULINUM TOXIN FRAGMENTS AND OTHER BOTULINUM TOXIN DERIVATIVES FOR THE TREATMENT OF NEUROLOGICAL DISORDERS; PHARMACEUTICAL PREPARATIONS CONTAINING BOTULINUM TOXIN WITH SPECIFIED COMPONENT(S) OF THE TOXIN HAEMAGGLUTIN COMPLEX FOR THE TREATMENT OF NEUROLOGICAL DISORDERS; PHARMACEUTICAL PREPARATIONS FOR THE TREATMENT AND PREVENTION OF NEUROMUSCULAR DISORDERS; PHARMACEUTICAL PREPARATIONS FOR THE TREATMENT AND PREVENTION OF CERVICAL DYSTONIA, CEREBRAL PALSY, AND SPASTICITY (U.S. CLS. 6, 18, 44, 46, 51 AND 52).

FIRST USE 12-13-2010; IN COMMERCE 12-13-2010.

3,941,878. ABBOTT LABORATORIES, ABBOTT PARK, IL. SN 77-930,870. PUB. 8-31-2010, FILED 2-8-2010.



THE COLOR(S) GOLD AND WHITE IS/ARE CLAIMED AS A FEATURE OF THE MARK.

THE MARK CONSISTS OF AN UPSIDE DOWN TRIANGULAR SHAPED SHIELD ENCOMPASSED WITHIN A SMALLER TRIANGULAR SHIELD. THE SHIELD DESIGNS ARE IN GOLD AND SEPARATED BY A WHITE OUTLINE.

FOR PROPRIETARY BLEND OF INGREDIENTS, SOLD AS AN INTEGRAL COMPONENT OF INFANT FORMULA, NAMELY, MIX OF IMMUNE SUPPORTING NUCLEOTIDES, PREBIOTICS AND CAROTENOIDS, DHA (OMEGA-3) AND ARA (OMEGA-6) CARBOHYDRATES, FATS, ANTIOXIDANTS AND VITAMINS AND OTHER DIETARY SUPPLEMENTS DESIGNED TO MAXIMIZE BABY HEALTH, IMMUNE SYSTEM, BRAIN AND EYES AND STRONG BONES (U.S. CLS. 6, 18, 44, 46, 51 AND 52).

FIRST USE 4-30-2010; IN COMMERCE 4-30-2010.

**CLASS 5—(Continued).**

3,941,879. ABBOTT LABORATORIES, ABBOTT PARK, IL. SN 77-930,875. PUB. 10-26-2010, FILED 2-8-2010.



OWNER OF U.S. REG. NO. 3,607,067.

THE COLOR(S) GOLD, BLUE AND WHITE IS/ARE CLAIMED AS A FEATURE OF THE MARK.

THE MARK CONSISTS OF A GOLD UPSIDE DOWN TRIANGULAR SHAPED SHIELD ENCOMPASSED WITHIN A SMALLER GOLD TRIANGULAR SHIELD WITH THE WORD "EARLYSHIELD" IN BLUE IN THE MIDDLE. THE SHIELD DESIGNS ARE IN GOLD AND SEPARATED BY A WHITE OUTLINE.

FOR PROPRIETARY BLEND OF INGREDIENTS, SOLD AS AN INTEGRAL COMPONENT OF INFANT FORMULA, NAMELY, MIX OF IMMUNE SUPPORTING NUCLEOTIDES, PREBIOTICS AND CAROTENOIDS, DHA (OMEGA-3) AND ARA (OMEGA-6) CARBOHYDRATES, FATS, ANTIOXIDANTS AND VITAMINS AND OTHER DIETARY SUPPLEMENTS DESIGNED TO MAXIMIZE BABY HEALTH, IMMUNE SYSTEM, BRAIN AND EYES AND STRONG BONES (U.S. CLS. 6, 18, 44, 46, 51 AND 52).

FIRST USE 4-30-2010; IN COMMERCE 4-30-2010.

3,941,916. GENERAL NUTRITION INVESTMENT COMPANY, PHOENIX, AZ. SN 77-941,108. PUB. 5-25-2010, FILED 2-22-2010.

# GNC PETS

THE MARK CONSISTS OF STANDARD CHARACTERS WITHOUT CLAIM TO ANY PARTICULAR FONT, STYLE, SIZE, OR COLOR.

OWNER OF U.S. REG. NOS. 1,786,007, 3,429,065, AND OTHERS.

NO CLAIM IS MADE TO THE EXCLUSIVE RIGHT TO USE "PETS", APART FROM THE MARK AS SHOWN.

FOR DIETARY SUPPLEMENTS FOR PETS (U.S. CLS. 6, 18, 44, 46, 51 AND 52).

FIRST USE 9-20-2010; IN COMMERCE 9-20-2010.



**CLASS 5—(Continued).**

3,941,926. AMERICAN COVERS, INC., BLUFFDALE, UT. SN 77-943,671. PUB. 7-20-2010, FILED 2-24-2010.

# DRIVEN

THE MARK CONSISTS OF STANDARD CHARACTERS WITHOUT CLAIM TO ANY PARTICULAR FONT, STYLE, SIZE, OR COLOR.  
FOR AIR FRESHENERS (U.S. CLS. 6, 18, 44, 46, 51 AND 52).  
FIRST USE 11-2-2010; IN COMMERCE 11-15-2010.

3,941,950. HYPERBRANCH MEDICAL TECHNOLOGY, INC., DURHAM, NC. SN 77-951,304. PUB. 8-31-2010, FILED 3-5-2010.

# ADHERUS

THE MARK CONSISTS OF STANDARD CHARACTERS WITHOUT CLAIM TO ANY PARTICULAR FONT, STYLE, SIZE, OR COLOR.  
FOR SYNTHETIC LIQUID HYDROGEL-BASED SEALANT USED TO CREATE A WATERTIGHT SEAL FOR TISSUE APPROXIMATION IN SURGICAL AND TRAUMA CASES FOR MEDICAL AND VETERINARY USE (U.S. CLS. 6, 18, 44, 46, 51 AND 52).  
FIRST USE 3-10-2010; IN COMMERCE 6-3-2010.

3,941,963. HYDRO ONE LLC, AUGUSTA, GA. SN 77-956,826. PUB. 9-7-2010, FILED 3-11-2010.

# TRÜE

THE MARK CONSISTS OF STANDARD CHARACTERS WITHOUT CLAIM TO ANY PARTICULAR FONT, STYLE, SIZE, OR COLOR.  
FOR NUTRITIONALLY FORTIFIED BEVERAGES (U.S. CLS. 6, 18, 44, 46, 51 AND 52).  
FIRST USE 4-20-2010; IN COMMERCE 5-15-2010.

**CLASS 5—(Continued).**

3,941,976. HUNTER'S SPECIALTIES, INC., CEDAR RAPIDS, IA. SN 77-959,995. PUB. 8-10-2010, FILED 3-16-2010.

# VITA-RACK GORGE

THE MARK CONSISTS OF STANDARD CHARACTERS WITHOUT CLAIM TO ANY PARTICULAR FONT, STYLE, SIZE, OR COLOR.  
OWNER OF U.S. REG. NO. 2,748,935.  
FOR ANIMAL FEED FOR USE AS A NUTRITIONAL SUPPLEMENT (U.S. CLS. 6, 18, 44, 46, 51 AND 52).  
FIRST USE 7-31-2010; IN COMMERCE 7-31-2010.

3,941,998. DANIEL CABRERA JR, DBA REALITY PRODUCTS LLC, FORT WORTH, TX. SN 77-969,195. PUB. 8-17-2010, FILED 3-26-2010.



THE COLOR(S) BLUE, ORANGE, WHITE IS/ARE CLAIMED AS A FEATURE OF THE MARK.  
THE MARK CONSISTS OF LIGHT BLUE BACKGROUND WITH ORANGE LETTERS, ONE WHITE LINE ABOVE AND BELOW THE NAME.  
FOR SPRAY SANITIZER FOR PERSONAL USE (U.S. CLS. 6, 18, 44, 46, 51 AND 52).  
FIRST USE 1-1-2009; IN COMMERCE 1-1-2011.

3,942,044. HERBALS USA, LLC, SEWICKLEY, PA. SN 77-981,432. PUB. 11-17-2009, FILED 1-7-2009.

# LONGEVITY FACTORS

THE MARK CONSISTS OF STANDARD CHARACTERS WITHOUT CLAIM TO ANY PARTICULAR FONT, STYLE, SIZE, OR COLOR.  
FOR NUTRACEUTICAL SUPPLEMENTS IN PILL FORM, NAMELY, DIETARY AND NUTRITIONAL SUPPLEMENTS AND MINERAL NUTRITIONAL SUPPLEMENTS (U.S. CLS. 6, 18, 44, 46, 51 AND 52).  
FIRST USE 6-29-2010; IN COMMERCE 6-29-2010.

**CLASS 5—(Continued).**

3,942,113. CTA RESPONSE GROUP, LLC, BRADFORD, MA. SN 85-017,193. PUB. 6-15-2010, FILED 4-19-2010.

# Complexin

THE MARK CONSISTS OF STANDARD CHARACTERS WITHOUT CLAIM TO ANY PARTICULAR FONT, STYLE, SIZE, OR COLOR.  
FOR DIETARY AND NUTRITIONAL SUPPLEMENTS (U.S. CLS. 6, 18, 44, 46, 51 AND 52).  
FIRST USE 6-24-2010; IN COMMERCE 6-24-2010.

3,942,122. MILK PRODUCTS, LLC, CHILTON, WI. SN 85-022,682. PUB. 9-28-2010, FILED 4-26-2010.

# SAV-A-CHICK

THE MARK CONSISTS OF STANDARD CHARACTERS WITHOUT CLAIM TO ANY PARTICULAR FONT, STYLE, SIZE, OR COLOR.  
FOR ELECTROLIGHT SUPPLEMENT FOR ANIMALS (U.S. CLS. 6, 18, 44, 46, 51 AND 52).  
FIRST USE 6-28-2010; IN COMMERCE 6-28-2010.

3,942,150. BELOVED BEASTS, LLC, THORNTON, CO. SN 85-034,451. PUB. 10-12-2010, FILED 5-10-2010.

# ENDURAPET

THE MARK CONSISTS OF STANDARD CHARACTERS WITHOUT CLAIM TO ANY PARTICULAR FONT, STYLE, SIZE, OR COLOR.  
FOR DIETARY SUPPLEMENTS FOR ANIMALS (U.S. CLS. 6, 18, 44, 46, 51 AND 52).  
FIRST USE 9-27-2010; IN COMMERCE 9-27-2010.

**CLASS 5—(Continued).**

3,942,178. HFP PRODUCTS LLC, BIG PRAIRIE, OH. SN 85-045,655. PUB. 11-9-2010, FILED 5-22-2010.



THE MARK CONSISTS OF THE WORDING "HIGH FIBER-IT" AND DESIGN. THE WORDING IS CENTERED INSIDE A RECTANGULAR BOX OUTLINED BY RAGGED TORN EDGES. A SHADED LINE BEGINS ON THE LEFT SIDE OF THE RAGGED OUTLINE NEAR THE CORNER AND GOES UP AND BEHIND THE LEFT CORNER OF THE BOX AND REAPPEARS AND CONTINUES FROM THE TOP TOWARDS THE RIGHT CORNER ABOVE THE WORD "HIGH". THE OUTLINE OF THE BOX IS SHADED TO ACCENT THE TORN EDGES.

FOR DIETARY FIBER AS AN ADDITIVE FOR FOOD PRODUCTS (U.S. CLS. 6, 18, 44, 46, 51 AND 52).  
FIRST USE 12-21-2010; IN COMMERCE 12-21-2010.

3,942,183. OCTALEAN, LLC, VERMILION, OH. SN 85-046,546. PUB. 10-19-2010, FILED 5-24-2010.

# octalean

THE MARK CONSISTS OF STANDARD CHARACTERS WITHOUT CLAIM TO ANY PARTICULAR FONT, STYLE, SIZE, OR COLOR.

FOR DIET CAPSULES; DIET PILLS; DIETARY SUPPLEMENTS; DIETING PILLS AND POWDER PREPARATIONS TO PROMOTE FAT BURNING (U.S. CLS. 6, 18, 44, 46, 51 AND 52).  
FIRST USE 6-1-2010; IN COMMERCE 6-1-2010.

3,942,208. GASPARI NUTRITION, INC., LAKEWOOD, NJ. SN 85-051,821. PUB. 10-26-2010, FILED 6-1-2010.

# SPIRODEX

THE MARK CONSISTS OF STANDARD CHARACTERS WITHOUT CLAIM TO ANY PARTICULAR FONT, STYLE, SIZE, OR COLOR.  
FOR DIETARY AND NUTRITIONAL SUPPLEMENTS (U.S. CLS. 6, 18, 44, 46, 51 AND 52).  
FIRST USE 8-15-2010; IN COMMERCE 8-15-2010.

**CLASS 5—(Continued).**

3,942,209. GASPARI NUTRITION, INC., LAKEWOOD, NJ. SN 85-051,823. PUB. 10-26-2010, FILED 6-1-2010.

**SPIRO TABS**

THE MARK CONSISTS OF STANDARD CHARACTERS WITHOUT CLAIM TO ANY PARTICULAR FONT, STYLE, SIZE, OR COLOR.

FOR DIETARY AND NUTRITIONAL SUPPLEMENTS (U.S. CLS. 6, 18, 44, 46, 51 AND 52).  
FIRST USE 8-15-2010; IN COMMERCE 8-15-2010.

3,942,220. SOAKED UP, INC., NEW YORK, NY. SN 85-054,171. PUB. 11-2-2010, FILED 6-3-2010.

**Hangunder**

THE MARK CONSISTS OF STANDARD CHARACTERS WITHOUT CLAIM TO ANY PARTICULAR FONT, STYLE, SIZE, OR COLOR.

FOR DIETARY BEVERAGE SUPPLEMENTS FOR HUMAN CONSUMPTION IN LIQUID AND DRY MIX FORM FOR THERAPEUTIC PURPOSES; DIETARY SUPPLEMENT BEVERAGE FOR DEHYDRATION; DIETARY SUPPLEMENTAL DRINKS; POWDERED FRUIT-FLAVORED DIETARY SUPPLEMENT DRINK MIX (U.S. CLS. 6, 18, 44, 46, 51 AND 52).  
FIRST USE 1-1-2011; IN COMMERCE 1-1-2011.

3,942,246. I AM PRODUCTS, LLC, WASHINGTON CROSSING, PA. SN 85-063,866. PUB. 11-16-2010, FILED 6-15-2010.

**I AM SLEEPY**

THE MARK CONSISTS OF STANDARD CHARACTERS WITHOUT CLAIM TO ANY PARTICULAR FONT, STYLE, SIZE, OR COLOR.

FOR NUTRITIONAL SUPPLEMENTS IN THE NATURE OF VITAMIN, MINERAL, AND HERB DRINKS (U.S. CLS. 6, 18, 44, 46, 51 AND 52).  
FIRST USE 1-3-2011; IN COMMERCE 1-3-2011.

**CLASS 5—(Continued).**

3,942,256. PRIMAL NUTRITION, INC., MALIBU, CA. SN 85-065,854. PUB. 10-19-2010, FILED 6-17-2010.

**PRIMAL FUEL**

THE MARK CONSISTS OF STANDARD CHARACTERS WITHOUT CLAIM TO ANY PARTICULAR FONT, STYLE, SIZE, OR COLOR.

FOR FOOD AND DIETARY SUPPLEMENTS (U.S. CLS. 6, 18, 44, 46, 51 AND 52).  
FIRST USE 8-14-2010; IN COMMERCE 8-14-2010.

3,942,295. NEILMED PRODUCTS, INC., SANTA ROSA, CA. SN 85-080,347. PUB. 12-7-2010, FILED 7-8-2010.

**SINUSURF**

THE MARK CONSISTS OF STANDARD CHARACTERS WITHOUT CLAIM TO ANY PARTICULAR FONT, STYLE, SIZE, OR COLOR.

OWNER OF U.S. REG. NOS. 3,410,449 AND 3,674,550.  
FOR PHARMACEUTICAL PREPARATIONS FOR TREATMENT OF NASAL AND SINUS AILMENTS (U.S. CLS. 6, 18, 44, 46, 51 AND 52).  
FIRST USE 11-4-2010; IN COMMERCE 11-4-2010.

3,942,319. ALOE VERA OF AMERICA, INC., DALLAS, TX. SN 85-099,834. PUB. 11-16-2010, FILED 8-4-2010.

**ARGI+**

THE MARK CONSISTS OF STANDARD CHARACTERS WITHOUT CLAIM TO ANY PARTICULAR FONT, STYLE, SIZE, OR COLOR.

FOR DIETARY AND NUTRITIONAL SUPPLEMENTS IN TABLET, CAPSULE AND POWDERED FORM CONTAINING AMINO ACIDS (U.S. CLS. 6, 18, 44, 46, 51 AND 52).  
FIRST USE 8-20-2010; IN COMMERCE 8-20-2010.

**CLASS 6—METAL GOODS**

**CLASS 6—(Continued).**

3,941,009. ALLFAST FASTENING SYSTEMS, INC., CITY OF INDUSTRY, CA. SN 77-000,943. PUB. 11-27-2007, FILED 9-15-2006.

**MEGAMAX**

THE MARK CONSISTS OF STANDARD CHARACTERS WITHOUT CLAIM TO ANY PARTICULAR FONT, STYLE, SIZE, OR COLOR.

OWNER OF U.S. REG. NOS. 1,393,782 AND 2,030,415. FOR FASTENERS MADE PRIMARILY OF METAL, NAMELY, RIVETS AND BLIND FASTENERS FOR USE IN THE AEROSPACE INDUSTRY (U.S. CLS. 2, 12, 13, 14, 23, 25 AND 50).

FIRST USE 2-17-2011; IN COMMERCE 2-17-2011.

3,941,458. EMERALD METALS LLC, HOUSTON, TX. SN 77-825,626. PUB. 7-6-2010, FILED 9-14-2009.

**CLADMAX**

THE MARK CONSISTS OF STANDARD CHARACTERS WITHOUT CLAIM TO ANY PARTICULAR FONT, STYLE, SIZE, OR COLOR.

FOR SEAMLESS METAL CLAD PIPES AND TUBES IN VARIOUS SIZES RANGING FROM A ONE INCH OUTSIDE DIAMETER THROUGH A 42 INCH DIAMETER AND PRODUCED THROUGH THE PROCESS OF CENTRIFUGAL CASTING IN TWO STAGES TO ACHIEVE A BONDED AND UNIFIED PRODUCT; METALLIC CAST PIPES AND TUBES, NAMELY, BI-METALLIC CAST PIPES AND TUBES COMPOSED OF PURCHASER-SPECIFIED METALLIC GRADE COMBINATIONS, INCLUDING CARBON PLUS CHROME CARBIDE, CARBON PLUS ALLOY 825, CARBON PLUS ALLOY 625, CARBON PLUS STAINLESS STEELS IN THE 300 AND 400 SERIES (U.S. CLS. 2, 12, 13, 14, 23, 25 AND 50).

FIRST USE 8-1-2009; IN COMMERCE 9-30-2009.

**CLASS 6—(Continued).**

3,941,509. KELLER, WILLIAM R., SR., EPHRATA, PA. SN 77-854,598. PUB. 5-4-2010, FILED 10-22-2009.

**PRO-FOOTER**

THE MARK CONSISTS OF STANDARD CHARACTERS WITHOUT CLAIM TO ANY PARTICULAR FONT, STYLE, SIZE, OR COLOR.

FOR METAL ANCHORING DEVICES FOR SECURING CONCRETE FOOTERS TO IN-GROUND POSTS (U.S. CLS. 2, 12, 13, 14, 23, 25 AND 50).

FIRST USE 2-7-2010; IN COMMERCE 2-7-2010.

3,941,585. CREGO METAL SYSTEMS, INC., ALBUQUERQUE, NM. SN 77-879,106. PUB. 4-20-2010, FILED 11-23-2009.

**CREGOSEAM**

THE MARK CONSISTS OF STANDARD CHARACTERS WITHOUT CLAIM TO ANY PARTICULAR FONT, STYLE, SIZE, OR COLOR.

FOR ROOFING COMPONENTS, NAMELY, METAL ROOFING PANELS (U.S. CLS. 2, 12, 13, 14, 23, 25 AND 50).

FIRST USE 7-31-2010; IN COMMERCE 7-31-2010.

3,941,586. CREGO METAL SYSTEMS, INC., ALBUQUERQUE, NM. SN 77-879,136. PUB. 4-20-2010, FILED 11-23-2009.

**CREGOLOCK**

THE MARK CONSISTS OF STANDARD CHARACTERS WITHOUT CLAIM TO ANY PARTICULAR FONT, STYLE, SIZE, OR COLOR.

FOR ROOFING COMPONENTS, NAMELY, METAL ROOFING PANELS (U.S. CLS. 2, 12, 13, 14, 23, 25 AND 50).

FIRST USE 7-31-2010; IN COMMERCE 7-31-2010.

**CLASS 6—(Continued).**

3,941,848. PUROLATOR EFP, LLC, HOUSTON, TX. SN 77-925,990. PUB. 6-15-2010, FILED 2-2-2010.

**PUROMETAL**

THE MARK CONSISTS OF STANDARD CHARACTERS WITHOUT CLAIM TO ANY PARTICULAR FONT, STYLE, SIZE, OR COLOR.

FOR SHATTERED METAL FILTER MEDIA (U.S. CLS. 2, 12, 13, 14, 23, 25 AND 50).  
FIRST USE 11-24-2010; IN COMMERCE 11-24-2010.

3,941,904. KOC, THOMAS, NORTH ARLINGTON, NJ. SN 77-936,764. PUB. 6-29-2010, FILED 2-16-2010.



NO CLAIM IS MADE TO THE EXCLUSIVE RIGHT TO USE "INC.", APART FROM THE MARK AS SHOWN.

THE MARK CONSISTS OF FRONT VIEW OF UPPER PART OF AN ANIMAL'S OVAL SHAPED FACE SHOWING TWO EYES AND FUR THEREON WITH LITERAL ELEMENT "PREDATOR" AT TOP OF FACE, THE "O" OF WHICH IS AN EYEBALL AND "INC." APPEARING AT BOTTOM OF THE FACE.

FOR DOOR FITTINGS OF METAL; METAL DOOR HARDWARE, NAMELY, KEYS AND KEY CYLINDERS; DOOR STOPS OF METAL; LOCK CYLINDERS OF METAL; METAL BALL LOCK PINS; METAL CABINET DOOR CATCHES; METAL CHAIN DOOR GUARDS; METAL CLASPS FOR DOOR SECURITY HARDWARE; METAL DOOR BOLTS; METAL DOOR HARDWARE, NAMELY, NON-POWERED DOOR ACTUATORS; METAL DOOR LATCHES; METAL LOCKING MECHANISMS; METAL LOCKS; METAL LOCKS AND KEYS THEREFOR; METAL LOCKS FOR DOORS; METAL MULTI-POINT LOCKING SYSTEM IN A WOOD DOOR; METAL SASH LOCKS; METAL SECURITY LOCK CYLINDERS (U.S. CLS. 2, 12, 13, 14, 23, 25 AND 50).  
FIRST USE 9-1-2010; IN COMMERCE 1-24-2011.

**CLASS 6—(Continued).**

3,941,987. PLUMLEE, GREG, FOOTHILL RANCH, CA. AND PLUMLEE, RENEE, FOOTHILL RANCH, CA. SN 77-963,953. PUB. 8-10-2010, FILED 3-19-2010.



NO CLAIM IS MADE TO THE EXCLUSIVE RIGHT TO USE "BEV" AND THE DESIGN OF A LID, APART FROM THE MARK AS SHOWN.

THE MARK CONSISTS OF THE WORDING "BEV HAT" IN A STYLIZED FONT AND A DESIGN THAT CONSISTS OF TWO CONCENTRIC CIRCLES ENCLOSING A BEVERAGE GLASS WITH A LID COVERING THE GLASS.

FOR A DEVICE, NAMELY, METAL LID, TO PREVENT BUGS AND DEBRIS FROM ENTERING A BEVERAGE CONTAINER (U.S. CLS. 2, 12, 13, 14, 23, 25 AND 50).  
FIRST USE 2-2-2011; IN COMMERCE 2-2-2011.

3,942,314. TRUCKVAULT, INC., SEDRO WOOLLEY, WA. SN 85-095,222. PUB. 10-19-2010, FILED 7-28-2010.

**SOLO-VAULT**

THE MARK CONSISTS OF STANDARD CHARACTERS WITHOUT CLAIM TO ANY PARTICULAR FONT, STYLE, SIZE, OR COLOR.

FOR METAL SAFES FOR GUNS (U.S. CLS. 2, 12, 13, 14, 23, 25 AND 50).  
FIRST USE 8-1-2010; IN COMMERCE 8-1-2010.

**CLASS 7—MACHINERY**

**CLASS 7—(Continued).**

3,941,080. BRIGGS AND STRATTON CORPORATION, WAUWATOSA, WI. SN 77-448,173. PUB. 10-7-2008, FILED 4-15-2008.



OWNER OF U.S. REG. NO. 3,335,964.

FOR ENGINES FOR ALL OF THE FOLLOWING: WALK BEHIND AND RIDING LAWN MOWERS, AIR COMPRESSORS, HYDRAULIC PUMPS, GENERATORS, GARDEN TILLERS, MULTI-PURPOSE HIGH PRESSURE WASHERS FOR CLEANING, SNOW THROWERS, FLOOR SWEEPERS (U.S. CLS. 13, 19, 21, 23, 31, 34 AND 35).

FIRST USE 12-1-2005; IN COMMERCE 12-1-2005.

3,941,085. W.C. BRANHAM, INC., RIVER FALLS, WI. SN 77-473,410. PUB. 2-2-2010, FILED 5-13-2008.

## Solutions in Motion

THE MARK CONSISTS OF STANDARD CHARACTERS WITHOUT CLAIM TO ANY PARTICULAR FONT, STYLE, SIZE, OR COLOR.

FOR FLUID POWER, POWER TRANSMISSION AND MOTION CONTROL INDUSTRIAL MACHINERY, NAMELY, PNEUMATIC LINEAR ACTUATORS, CALIPER DISC BRAKES FOR MACHINES, RIGHT ANGLE GEAR DRIVES FOR INDUSTRIAL MACHINERY, GEARBOXES OTHER THAN FOR LAND VEHICLES, AND PNEUMATIC DOOR OPENING SYSTEMS (U.S. CLS. 13, 19, 21, 23, 31, 34 AND 35).

FIRST USE 4-0-1994; IN COMMERCE 4-0-1994.

3,941,086. W.C. BRANHAM, INC., RIVER FALLS, WI. SN 77-473,442. PUB. 4-27-2010, FILED 5-13-2008.

## W. C. BRANHAM

THE MARK CONSISTS OF STANDARD CHARACTERS WITHOUT CLAIM TO ANY PARTICULAR FONT, STYLE, SIZE, OR COLOR.

**CLASS 7—(Continued).**

SEC. 2(F).

FOR FLUID POWER, POWER TRANSMISSION AND MOTION CONTROL INDUSTRIAL MACHINERY, NAMELY, PNEUMATIC LINEAR ACTUATORS, CALIPER DISC BRAKES FOR MACHINES, RIGHT ANGLE GEAR DRIVES FOR INDUSTRIAL MACHINERY, GEARBOXES OTHER THAN FOR LAND VEHICLES, AND PNEUMATIC DOOR OPENING SYSTEMS (U.S. CLS. 13, 19, 21, 23, 31, 34 AND 35).

FIRST USE 7-1-2008, THE MARK WAS FIRST USED ANYWHERE IN A DIFFERENT FORM OTHER THAN THAT SOUGHT TO BE REGISTERED AT LEAST AS EARLY AS 12/23/1996.; IN COMMERCE 7-1-2008, THE MARK WAS FIRST USED IN COMMERCE IN A DIFFERENT FORM OTHER THAN THAT SOUGHT TO BE REGISTERED AT LEAST AS EARLY AS 12/23/1996..

3,941,110. PALFINGER AG, 5101 BERGHEIM, AUSTRIA. SN 77-525,023. PUB. 11-18-2008, FILED 7-17-2008.

## EPSILON PALFINGER

THE MARK CONSISTS OF STANDARD CHARACTERS WITHOUT CLAIM TO ANY PARTICULAR FONT, STYLE, SIZE, OR COLOR.

OWNER OF U.S. REG. NOS. 1,321,474 AND 2,529,916.

FOR TIMBER AND SCRAP CRANES (U.S. CLS. 13, 19, 21, 23, 31, 34 AND 35).

FIRST USE 12-0-2009; IN COMMERCE 6-0-2010.

3,941,156. MARATHON EQUIPMENT COMPANY (DELAWARE), VERNON, AL. SN 77-605,109. PUB. 4-20-2010, FILED 10-31-2008.

## NEXGEN

THE MARK CONSISTS OF STANDARD CHARACTERS WITHOUT CLAIM TO ANY PARTICULAR FONT, STYLE, SIZE, OR COLOR.

FOR CONVEYORS FOR WASTE, RECYCLING, AND MATERIAL HANDLING, AND PARTS THEREOF (U.S. CLS. 13, 19, 21, 23, 31, 34 AND 35).

FIRST USE 10-21-2010; IN COMMERCE 10-21-2010.

**CLASS 7—(Continued).**

3,941,179. LYONS, LEON, SCOTTSDALE, AZ. SN 77-633,960.  
PUB. 4-21-2009, FILED 12-16-2008.

**SWEEPEASE**

THE MARK CONSISTS OF STANDARD CHARACTERS WITHOUT CLAIM TO ANY PARTICULAR FONT, STYLE, SIZE, OR COLOR.

FOR SWIMMING POOL SWEEPERS (U.S. CLS. 13, 19, 21, 23, 31, 34 AND 35).

FIRST USE 9-3-2010; IN COMMERCE 1-1-2011.

---

3,941,198. WATER TECH, LLC, EAST BRUNSWICK, NJ. SN 77-649,686. PUB. 4-28-2009, FILED 1-14-2009.

**HYDRO BROOM**

THE MARK CONSISTS OF STANDARD CHARACTERS WITHOUT CLAIM TO ANY PARTICULAR FONT, STYLE, SIZE, OR COLOR.

OWNER OF U.S. REG. NOS. 3,402,529 AND 3,454,453.

NO CLAIM IS MADE TO THE EXCLUSIVE RIGHT TO USE "HYDRO", APART FROM THE MARK AS SHOWN.

FOR POOL, SPA AND WATER CLEANING DEVICES, NAMELY, POOL AND SPA VACUUMS (U.S. CLS. 13, 19, 21, 23, 31, 34 AND 35).

FIRST USE 12-19-2010; IN COMMERCE 12-19-2010.

---

3,941,734. SMITH INTERNATIONAL, INC., HOUSTON, TX. SN 77-907,998. PUB. 5-25-2010, FILED 1-8-2010.

**HPS-V3**

THE MARK CONSISTS OF STANDARD CHARACTERS WITHOUT CLAIM TO ANY PARTICULAR FONT, STYLE, SIZE, OR COLOR.

FOR OIL AND GAS FIELD EQUIPMENT, NAMELY, MACHINES IN THE NATURE OF DOWNHOLE WELL TOOLS, NAMELY, LINER HANGERS AND LINER PACKERS (U.S. CLS. 13, 19, 21, 23, 31, 34 AND 35).

FIRST USE 10-31-2010; IN COMMERCE 10-31-2010.

**CLASS 7—(Continued).**

3,942,135. GENERAL ELECTRIC COMPANY, SCHENECTADY, NY. SN 85-026,081. PUB. 7-27-2010, FILED 4-29-2010.

**SINGLET**

THE MARK CONSISTS OF STANDARD CHARACTERS WITHOUT CLAIM TO ANY PARTICULAR FONT, STYLE, SIZE, OR COLOR.

FOR STEAM TURBINE COMPONENTS, NAMELY, NOZZLE ASSEMBLY (U.S. CLS. 13, 19, 21, 23, 31, 34 AND 35).

FIRST USE 12-31-2010; IN COMMERCE 12-31-2010.

---

3,942,148. WALTON, JOHN, A, DBA JACKPOINT JACKSTANDS, BATAVIA, IL. SN 85-033,660. PUB. 10-19-2010, FILED 5-8-2010.



NO CLAIM IS MADE TO THE EXCLUSIVE RIGHT TO USE "JACK POINT" AND "JACK STANDS", APART FROM THE MARK AS SHOWN.

THE MARK CONSISTS OF THE WORDS "JACKPOINT JACKSTANDS" WITH THE "A" IN "JACKPOINT" REPLACED WITH THE IMAGE OF THE JACK STAND BASE AND THE DOT OF THE "I" IN "JACKPOINT" REPLACED BY AN IMAGE OF THE JACK STAND CAP. THE IMAGE OF THE JACK STAND BASE STANDS OUT AND SLIGHTLY OVERLAPS THE "J" AND THE "C" IN "JACKPOINT" AND THE LETTERS IN "JACKPOINT" ARE SLANTED WITH THE IMAGE BEING STRAIGHT UPRIGHT.

FOR STANDS FOR HYDRAULIC JACKS (U.S. CLS. 13, 19, 21, 23, 31, 34 AND 35).

FIRST USE 3-1-2010; IN COMMERCE 12-8-2010.

**CLASS 7—(Continued).**

3,942,151. XU YUAN PACKAGING TECHNOLOGY CO., LTD., HSIN-CHU HSIEN, 30352, TAIWAN. SN 85-035,056. PUB. 10-5-2010, FILED 5-11-2010.



THE MARK CONSISTS OF THE STYLIZED LETTERS "XYP" BENEATH A RECTANGULAR CONTOUR HAVING AN ARCUATE SIDE WITH A WORLD GLOBE DESIGN HAVING A PARTIAL ENCIRCLEMENT BY A RING LIKE CONTOUR SUPERIMPOSED OVER THE RECTANGULAR CONTOUR.

FOR PACKAGING MACHINES; PACKING MACHINES; WRAPPING MACHINES; LABELING MACHINES, NAMELY, AUTOMATIC INDUSTRIAL LABELING MACHINES FOR APPLYING LABELS TO CONTAINERS AND BOTTLES; ROBOTIC ARMS FOR INDUSTRIAL PURPOSES (U.S. CLS. 13, 19, 21, 23, 31, 34 AND 35).

FIRST USE 2-28-2005; IN COMMERCE 6-30-2010.

3,942,252. E. MISHAN & SONS, INC., NEW YORK, NY. SN 85-065,249. PUB. 11-9-2010, FILED 6-17-2010.



THE COLOR(S) ORANGE, GRAY AND WHITE IS/ARE CLAIMED AS A FEATURE OF THE MARK.

THE MARK CONSISTS OF THE WORDING "TORPEDO" IN ORANGE, AND THE DESIGN OF A STYLIZED ORANGE, WHITE AND GRAY PROPELLER WITHIN THE "O".

FOR ELECTRIC BLENDERS FOR BLENDING FOOD AND BEVERAGES (U.S. CLS. 13, 19, 21, 23, 31, 34 AND 35).

FIRST USE 5-0-2010; IN COMMERCE 5-0-2010.

**CLASS 8—HAND TOOLS****CLASS 8—(Continued).**

3,941,024. FERGUSON ENTERPRISES, INC., NEWPORT NEWS, VA. SN 77-148,219. PUB. 1-1-2008, FILED 4-4-2007.

**PROSELECT**

THE MARK CONSISTS OF STANDARD CHARACTERS WITHOUT CLAIM TO ANY PARTICULAR FONT, STYLE, SIZE, OR COLOR.

OWNER OF U.S. REG. NO. 3,065,212.

FOR HAND TOOLS USED FOR PLUMBING, NAMELY, SOCKET SETS, WATER HEATER ELEMENT SOCKETS, PIPE CUTTERS, HANDLE PULLERS, NAMELY, HAND TOOLS USED TO PULL FAUCET HANDLES OFF THEIR FITTINGS, PIPE NIPPLE EXTRACTORS, SEAT WRENCHES, SPUD WRENCHES, STREET KEY, NAMELY, METAL HAND TOOLS USED TO TURN A WATER MAIN OFF AND ON AT STREET LOCATIONS, BASIN WRENCHES AND TUBING CUTTERS (U.S. CLS. 23, 28 AND 44).

FIRST USE 3-31-2009; IN COMMERCE 3-31-2009.

3,941,189. FISKARS CORPORATION, HELSINKI, FINLAND. SN 77-643,775. PUB. 5-5-2009, FILED 1-6-2009.

**DURASHARP**

THE MARK CONSISTS OF STANDARD CHARACTERS WITHOUT CLAIM TO ANY PARTICULAR FONT, STYLE, SIZE, OR COLOR.

OWNER OF U.S. REG. NO. 1,227,347.

FOR HAND OPERATED LAWN AND GARDEN TOOLS, NAMELY, LOPPERS AND HAND PRUNERS (U.S. CLS. 23, 28 AND 44).

FIRST USE 12-31-2010; IN COMMERCE 12-31-2010.

3,941,452. CHEF LOCKER, LLC, SAINT PETERS, MO. SN 77-821,094. PUB. 5-18-2010, FILED 9-6-2009.

**Chef Locker  
Secure Your Steel**

THE MARK CONSISTS OF STANDARD CHARACTERS WITHOUT CLAIM TO ANY PARTICULAR FONT, STYLE, SIZE, OR COLOR.

NO CLAIM IS MADE TO THE EXCLUSIVE RIGHT TO USE "CHEF LOCKER", APART FROM THE MARK AS SHOWN.

FOR BOXES SPECIALLY ADAPTED FOR THE STORAGE OF CUTLERY AND FLATWARE; CHEF KNIVES (U.S. CLS. 23, 28 AND 44).

FIRST USE 7-12-2010; IN COMMERCE 12-12-2010.



**CLASS 8—(Continued).**

3,941,712. SINDELAR, JAMES C., HOPKINTON, NH. SN 77-903,433. PUB. 5-18-2010, FILED 12-31-2009.

**YANKEE CATAPULT**

THE MARK CONSISTS OF STANDARD CHARACTERS WITHOUT CLAIM TO ANY PARTICULAR FONT, STYLE, SIZE, OR COLOR.

FOR SHOVELS; SNOW SHOVELS (U.S. CLS. 23, 28 AND 44).

FIRST USE 11-1-2010; IN COMMERCE 12-1-2010.

---

3,941,853. KENG, SHANE, ROSWELL, GA. SN 77-926,432. PUB. 7-20-2010, FILED 2-2-2010.

**Pocket Toolbox**

THE MARK CONSISTS OF STANDARD CHARACTERS WITHOUT CLAIM TO ANY PARTICULAR FONT, STYLE, SIZE, OR COLOR.

NO CLAIM IS MADE TO THE EXCLUSIVE RIGHT TO USE "POCKET", APART FROM THE MARK AS SHOWN.

FOR MULTI-FUNCTION HAND TOOLS COMPRISED OF SCREWDRIVERS, WRENCHES, PLIERS, FILES, SAWS; HAND TOOLS, NAMELY, HEX KEYS WRENCHES; HAND TOOLS, NAMELY, SCREWDRIVERS; HAND TOOLS, NAMELY, SOCKET SETS; HAND TOOLS, NAMELY, SOCKET WRENCHES; HAND TOOLS, NAMELY, WRENCHES; HAND-OPERATED DISARMING TOOLS FOR IMPROVISED EXPLOSIVE DEVICES (IED); HAND-TOOLS, NAMELY, WIRE CRIMPERS; KNIVES (U.S. CLS. 23, 28 AND 44).

FIRST USE 1-1-2010; IN COMMERCE 1-22-2010.

---

3,941,861. ONESTOP INC., TERRYVILLE, CT. SN 77-927,887. PUB. 12-14-2010, FILED 2-4-2010.

**SCORPION TATTOO SUPPLIES**

THE MARK CONSISTS OF STANDARD CHARACTERS WITHOUT CLAIM TO ANY PARTICULAR FONT, STYLE, SIZE, OR COLOR.

NO CLAIM IS MADE TO THE EXCLUSIVE RIGHT TO USE "TATTOO SUPPLIES", APART FROM THE MARK AS SHOWN.

FOR TATTOO MACHINE PARTS, NAMELY, SPRINGS AND ARMATURE BARS; TATTOO MACHINES; TATTOO NEEDLES (U.S. CLS. 23, 28 AND 44).

FIRST USE 11-28-2009; IN COMMERCE 11-28-2009.

**CLASS 8—(Continued).**

3,941,969. EVRIHOLDER PRODUCTS LLC, ANAHEIM, CA. SN 77-958,490. PUB. 7-6-2010, FILED 3-14-2010.

**EVRI TWEEZ 'N FILE**

THE MARK CONSISTS OF STANDARD CHARACTERS WITHOUT CLAIM TO ANY PARTICULAR FONT, STYLE, SIZE, OR COLOR.

NO CLAIM IS MADE TO THE EXCLUSIVE RIGHT TO USE "TWEEZE AND FILE", APART FROM THE MARK AS SHOWN.

FOR NAIL FILES; TWEEZERS (U.S. CLS. 23, 28 AND 44).

FIRST USE 3-14-2010; IN COMMERCE 9-27-2010.

---

3,942,242. CASEMARK, INC., WILMINGTON, DE. SN 85-061,132. PUB. 11-9-2010, FILED 6-11-2010.

**ROUGH BLACK**

THE MARK CONSISTS OF STANDARD CHARACTERS WITHOUT CLAIM TO ANY PARTICULAR FONT, STYLE, SIZE, OR COLOR.

FOR KNIVES AND CUTLERY (U.S. CLS. 23, 28 AND 44).

FIRST USE 9-20-2010; IN COMMERCE 9-20-2010.

**CLASS 9—ELECTRICAL AND SCIENTIFIC APPARATUS**

**CLASS 9—(Continued).**

3,940,983. UNIVERSAL ELECTRONICS INC., CYPRESS, CA.  
SN 76-675,762. PUB. 10-16-2007, FILED 4-20-2007.



THE MARK CONSISTS OF THE DESIGN OF A CRICKET.  
FOR REMOTE CONTROL UNITS FOR TELEVISIONS,  
VIDEO CASSETTE RECORDERS, CABLE BOXES,  
STEREO EQUIPMENT, SATELLITE DISHES, COMPU-  
TERS, LIGHTING AND FANS; WIRELESS KEYBOARDS;  
PERSONAL DIGITAL ASSISTANTS; AND HAND HELD  
WIRELESS COMPUTERS (U.S. CLS. 21, 23, 26, 36 AND  
38).

FIRST USE 6-0-2007; IN COMMERCE 6-0-2007.

3,941,004. EMPIONEER CORPORATION, LA PUENTE, CA.  
SN 76-702,741. PUB. 9-28-2010, FILED 4-23-2010.



THE MARK CONSISTS OF A STYLIZED "W" WITH  
HORIZONTAL LINE UNDERNEATH WHICH CURVES  
UPWARD PARTIALLY TO THE RIGHT.

FOR SUNGLASSES (U.S. CLS. 21, 23, 26, 36 AND 38).  
FIRST USE 1-26-2011; IN COMMERCE 1-26-2011.

3,941,007. ID SOFTWARE LLC, MESQUITE, TX. SN 76-  
979,115. PUB. 5-6-2008, FILED 11-30-2007.

**QUAKELIVE**

THE MARK CONSISTS OF STANDARD CHARACTERS  
WITHOUT CLAIM TO ANY PARTICULAR FONT, STYLE,  
SIZE, OR COLOR.

**CLASS 9—(Continued).**

OWNER OF U.S. REG. NOS. 2,032,587, 3,213,821, AND  
OTHERS.

FOR COMPUTER SOFTWARE GAMES AND COMPU-  
TER SOFTWARE GAME PROGRAMS FOR ENTERTAIN-  
MENT USES WITH USER MANUALS SOLD AS A UNIT  
(U.S. CLS. 21, 23, 26, 36 AND 38).

FIRST USE 2-24-2009; IN COMMERCE 8-6-2010.

3,941,010. WAVES AUDIO LTD., TEL AVIV, ISRAEL. SN 77-  
017,420. PUB. 7-10-2007, FILED 10-10-2006.

**MAXXAUDIO**

THE MARK CONSISTS OF STANDARD CHARACTERS  
WITHOUT CLAIM TO ANY PARTICULAR FONT, STYLE,  
SIZE, OR COLOR.

OWNER OF U.S. REG. NOS. 2,359,170, 2,847,596, AND  
3,070,047.

FOR SOFTWARE AND ELECTRONIC EQUIPMENT  
FOR PROCESSING, TRANSMITTING, RECEIVING  
AND REPRODUCING AUDIO SIGNALS IN ORDER TO  
ENHANCE BASS QUALITIES, NAMELY, DIGITAL  
AUDIO WORK STATIONS CONSISTING OF COMPUTER  
HARDWARE AND SOFTWARE FOR REPRODUCING  
AUDIO SIGNALS IN ORDER TO ENHANCE BASS  
QUALITIES; DIGITAL AND ANALOG AUDIO MIXING  
CONSOLES; HOME AUDIO APPLIANCES, NAMELY,  
RADIOS, TELEVISION SETS, STEREO SYSTEMS AND  
MINI STEREO SYSTEMS CONSISTING OF AUDIO  
AMPLIFIERS, TUNERS, RECEIVERS, AND CD AND  
AUDIO TAPE PLAYERS; AND VIDEO CASSETTE  
PLAYERS; PORTABLE AUDIO APPLIANCES, NAMELY,  
RADIOS AND MP3 PLAYERS; MAGNETIC AND OPTI-  
CAL MEDIA CARRYING AUDIO SIGNALS THAT WERE  
SUBJECT TO BASS ENHANCEMENT, NAMELY, RE-  
CORDS, CD'S, AUDIO TAPES, AND MINI-DISKS FEAT-  
URING MUSICAL SOUND RECORDINGS;  
ELECTRONIC PROCESSORS FOR USE IN THE REPRO-  
DUCTION OF RECORDED SOUND OR STREAMING OF  
SOUND; SOUND RECORDINGS EMBODYING EN-  
CODED INFORMATION FEATURING MUSICAL PER-  
FORMANCES; KIT FOR THE SELF-LEARNING OF  
RECORDING, PROCESSING, RESTORING, MIXING  
AND MASTERING OF AUDIO CONTENT, SAID KIT  
COMPRISING PRE-RECORDED INSTRUCTIONAL CD'S  
AND DVD'S AND ASSOCIATED MANUALS (U.S. CLS.  
21, 23, 26, 36 AND 38).

FIRST USE 8-31-2007; IN COMMERCE 8-31-2007.

**CLASS 9—(Continued).**

3,941,017. VIALOGY LLC, PASADENA, CA. SN 77-078,789.  
PUB. 8-21-2007, FILED 1-9-2007.

**NANOSPM**

THE MARK CONSISTS OF STANDARD CHARACTERS WITHOUT CLAIM TO ANY PARTICULAR FONT, STYLE, SIZE, OR COLOR.

FOR COMPUTER FIRMWARE AND HARDWARE POLICY BASED SYSTEM FOR PROCESSING OF VIDEO AND VIDEO ANALYTICS EMBEDDED WITHIN ANALOG, DIGITAL AND STILL AND VIDEO CAMERAS (U.S. CLS. 21, 23, 26, 36 AND 38).

FIRST USE 8-9-2010; IN COMMERCE 8-9-2010.

**CLASS 9—(Continued).**

3,941,034. WOOLPERT, INC., DAYTON, OH. SN 77-222,652.  
PUB. 12-25-2007, FILED 7-5-2007.

**SEDPRO**

THE MARK CONSISTS OF STANDARD CHARACTERS WITHOUT CLAIM TO ANY PARTICULAR FONT, STYLE, SIZE, OR COLOR.

FOR COMPUTER SOFTWARE PROGRAM FOR MODELING THE HYDROLOGY AND EROSION OF A LAND DEVELOPMENT SITE AND THE SEDIMENT TRANSFER AND TRAPPING EFFICIENCY OF SPECIFIC MANAGEMENT PRACTICES (U.S. CLS. 21, 23, 26, 36 AND 38).

FIRST USE 2-17-2011; IN COMMERCE 2-17-2011.

3,941,018. OAKLEY, INC., FOOTHILL RANCH, CA. SN 77-090,414. PUB. 6-1-2010, FILED 1-24-2007.

**PATH**

THE MARK CONSISTS OF STANDARD CHARACTERS WITHOUT CLAIM TO ANY PARTICULAR FONT, STYLE, SIZE, OR COLOR.

FOR PROTECTIVE EYEWEAR, NAMELY, SPECTACLES, PRESCRIPTION EYEWEAR, ANTI GLARE GLASSES AND SUNGLASSES AND THEIR PARTS AND ACCESSORIES, NAMELY, REPLACEMENT LENSES, FRAMES, EARSTEMS, AND NOSE PIECES; CASES SPECIALLY ADAPTED FOR SPECTACLES AND SUNGLASSES AND THEIR PARTS AND ACCESSORIES (U.S. CLS. 21, 23, 26, 36 AND 38).

FIRST USE 3-1-2007; IN COMMERCE 3-1-2007.

3,941,035. TECHNETIX GROUP LIMITED, BURGESS HILL, UNITED KINGDOM. SN 77-222,837. PUB. 6-8-2010, FILED 7-5-2007.

**Adapt-x**

THE MARK CONSISTS OF STANDARD CHARACTERS WITHOUT CLAIM TO ANY PARTICULAR FONT, STYLE, SIZE, OR COLOR.

FOR BROADBAND OR MULTI-MEDIA COMMUNICATIONS APPARATUS, NAMELY, CABLE BROADCAST TRANSMISSION MACHINES AND APPARATUS AND REPLACEMENT PARTS THEREOF; APPARATUS AND COMPONENTS FOR USE IN BROADBAND COMMUNICATIONS; TELECOMMUNICATIONS AND CABLE TELEVISION SYSTEMS, NAMELY, APPARATUS FOR THE SUPPLY OF SIGNALS FOR TELEVISION RECEIVERS AND ANTENNAE; SIGNAL TRANSMISSION, DISTRIBUTION AND RELAYING APPARATUS, NAMELY, DATA CONVERTERS, EQUALIZERS; SIGNAL DISTRIBUTION EQUIPMENT, NAMELY, TRANSMITTERS, RECEIVERS, SPLITTERS, SIGNAL SCRAMBLERS, MODULATORS AND DEMODULATORS; SIGNAL COMBINERS, NAMELY, ELECTRONIC COMBINERS FOR CONNECTING ANTENNAE AND DEMODULATORS; SIGNAL COMBINERS, NAMELY, ELECTRONIC COMBINERS FOR CONNECTING ANTENNAE AND RECEIVERS, DIGITAL SIGNAL SPLITTERS FOR ELECTRONIC APPARATUS, PERIPHERAL COMPONENT INTERFACE HARDWARE, AMPLIFIERS, SIGNAL CONDITIONING DEVICES AND FILTERS FOR INDUSTRIAL PROCESS CONTROL; APPARATUS FOR PROCESSING SIGNALS FOR DIGITAL TELEVISION, NAMELY, CABLE TELEVISION CONVERTERS; APPARATUS FOR SUPPLYING AND RELAYING SIGNALS FOR DIGITAL TELEVISION, NAMELY, TELEVISION RECEIVERS AND TRANSMITTERS; CLOSED-CIRCUIT TELEVISION SECURITY APPARATUS, NAMELY, VIDEO CAMERAS, CLOSED-CIRCUIT TELEVISION CAMERAS, TELEVISION MONITORS; APPARATUS FOR USE IN SECURITY CONTROL, NAMELY, ALARM DETECTION SYSTEMS, ACCESS CONTROL SYSTEMS, DIGITAL VIDEO RECORDERS; SECURITY MONITORING AND WARNING APPARATUS, NAMELY, SYSTEM PROTECTION AND SAFETY APPARATUS, NAMELY, VOLTAGE SURGE PROTECTORS; COMPONENTS FOR TELECOMMUNICATIONS APPARATUS AND INSTAL-

3,941,030. IGT, RENO, NV. SN 77-212,619. PUB. 12-11-2007, FILED 6-21-2007.

**AS GOOD AS GOLD**

THE MARK CONSISTS OF STANDARD CHARACTERS WITHOUT CLAIM TO ANY PARTICULAR FONT, STYLE, SIZE, OR COLOR.

FOR GAMING MACHINES, NAMELY, DEVICES WHICH ACCEPT A WAGER (U.S. CLS. 21, 23, 26, 36 AND 38).

FIRST USE 2-1-2011; IN COMMERCE 2-7-2011.

**CLASS 9—(Continued).**

LATIONS, NAMELY, ELECTRIC RESISTORS, ELECTRIC CAPACITORS; CABLE CONNECTION DEVICES, NAMELY, ELECTRIC PLUG DEVICE ENABLING CONNECTION AND DISCONNECTION OF POWER AND/OR CONTROL CABLES; HOUSINGS AND ENCLOSURES, NAMELY, ISOLATOR HOUSINGS FOR INTEGRATED CIRCUITS; LEADS, NAMELY, CABLE JUMP LEADS AND PATCH LEADS FOR CABLE INSTALLATIONS, CO-AXIAL CABLES, CABLE AND ELECTRIC CONNECTORS, TERMINATORS AND CO-AXIAL CABLE ADAPTERS; HIGH PASS AND LOW PASS INDUCTOR FILTERS USED IN ELECTRICAL APPLICATIONS; GALVANIC ISOLATORS; ETHERNET INTERFACES; TELEPHONE MODEMS; CABLE MODEMS; CONNECTION DEVICES, NAMELY, CONNECTION CABLES; COMPUTERS; COMPUTER PERIPHERALS; COMPUTER HARDWARE; COMPONENTS FOR DATA PROCESSING APPARATUS AND INSTALLATIONS, NAMELY, ISOLATORS, SPLITTERS, FILTERS; PARTS AND FITTINGS FOR THE AFOREMENTIONED (U.S. CLS. 21, 23, 26, 36 AND 38).

FIRST USE 1-1-2007; IN COMMERCE 1-1-2007.

---

3,941,043. IGT, RENO, NV. SN 77-273,259. PUB. 11-20-2007, FILED 9-6-2007.

**LUCKY FOX**

THE MARK CONSISTS OF STANDARD CHARACTERS WITHOUT CLAIM TO ANY PARTICULAR FONT, STYLE, SIZE, OR COLOR.

FOR GAMING MACHINES, NAMELY, DEVICES WHICH ACCEPT A WAGER (U.S. CLS. 21, 23, 26, 36 AND 38).

FIRST USE 12-20-2010; IN COMMERCE 12-28-2010.

---

3,941,059. YAHOO! INC., SUNNYVALE, CA. SN 77-354,213. PUB. 11-16-2010, FILED 12-17-2007.

**PINGBOX**

THE MARK CONSISTS OF STANDARD CHARACTERS WITHOUT CLAIM TO ANY PARTICULAR FONT, STYLE, SIZE, OR COLOR.

FOR DOWNLOADABLE COMPUTER SOFTWARE, AVAILABLE TO CONSUMERS AS AN AFTER-MARKET ADD-ON, FOR USE IN ENABLING INSTANT MESSAGING IN SOCIAL NETWORKS, BLOGS AND WEBSITES (U.S. CLS. 21, 23, 26, 36 AND 38).

FIRST USE 9-23-2008; IN COMMERCE 9-23-2008.

**CLASS 9—(Continued).**

3,941,061. IGLOBE, INC., FRANKLIN, NH. SN 77-366,497. PUB. 5-27-2008, FILED 1-8-2008.

**HYPERGLOBE**

THE MARK CONSISTS OF STANDARD CHARACTERS WITHOUT CLAIM TO ANY PARTICULAR FONT, STYLE, SIZE, OR COLOR.

FOR MULTIMEDIA PROJECTORS FOR PROJECTING IMAGES, VISUAL SIMULATIONS, VIDEO DISPLAYS, DIGITAL CONTENT OR INFORMATION ON THREE-DIMENSIONAL SURFACES FOR ADVERTISING, ENTERTAINMENT, AMUSEMENT, AND EDUCATIONAL PURPOSES; AND SOFTWARE FOR USE IN CONNECTION WITH SUCH PROJECTION (U.S. CLS. 21, 23, 26, 36 AND 38).

FIRST USE 12-13-2010; IN COMMERCE 12-13-2010.

---

3,941,074. MOTLEY CRUE, INC., SANTA MONICA, CA. SN 77-428,856. PUB. 3-10-2009, FILED 3-22-2008.

**GIRLS GIRLS GIRLS**

THE MARK CONSISTS OF STANDARD CHARACTERS WITHOUT CLAIM TO ANY PARTICULAR FONT, STYLE, SIZE, OR COLOR.

FOR PRERECORDED PHONOGRAPH RECORDS, PRERECORDED AUDIO CASSETTE TAPES, PRERECORDED CD'S, PRERECORDED DVD'S, PRERECORDED AUDIO-VISUAL RECORDS IN ANALOG DISC AND DIGITAL DISC CONFIGURATIONS AND ANALOG MAGNETIC TAPE AND DIGITAL MAGNETIC TAPE CONFIGURATIONS, PRERECORDED LASER DISKS, PRERECORDED RECORD ALBUMS, ALL CONTAINING MUSICAL RECORDINGS (U.S. CLS. 21, 23, 26, 36 AND 38).

FIRST USE 1-1-1987; IN COMMERCE 1-1-1987.

---

3,941,079. ARCADE PICTURES, LLC, SANTA MONICA, CA. SN 77-446,060. PUB. 5-26-2009, FILED 4-11-2008.

**ARCADE PICTURES**

THE MARK CONSISTS OF STANDARD CHARACTERS WITHOUT CLAIM TO ANY PARTICULAR FONT, STYLE, SIZE, OR COLOR.

**CLASS 9—(Continued).**

NO CLAIM IS MADE TO THE EXCLUSIVE RIGHT TO USE "PICTURES", APART FROM THE MARK AS SHOWN.

FOR PRERECORDED VIDEO TAPES, COMPACT DISCS, AND DVDS FEATURING ENTERTAINMENT AND MUSICAL SOUND RECORDINGS (U.S. CLS. 21, 23, 26, 36 AND 38).

FIRST USE 1-4-2011; IN COMMERCE 1-4-2011.

**CLASS 9—(Continued).**

3,941,108. STONE CREEK ENTERTAINMENT INC., RIDGEFIELD, CT. SN 77-521,764. PUB. 12-2-2008, FILED 7-14-2008.

3,941,089. A10 NETWORKS, INC., SAN JOSE, CA. SN 77-482,848. PUB. 5-5-2009, FILED 5-23-2008.

**KARIZMAC**

**ACOS**

THE MARK CONSISTS OF STANDARD CHARACTERS WITHOUT CLAIM TO ANY PARTICULAR FONT, STYLE, SIZE, OR COLOR.

FOR VIDEO GAME SOFTWARE, VIDEO GAME PROGRAMS; ELECTRONIC GAME SOFTWARE, ELECTRONIC GAME PROGRAMS; COMPUTER GAME SOFTWARE; DOWNLOADABLE COMPUTER GAME SOFTWARE (U.S. CLS. 21, 23, 26, 36 AND 38).

FIRST USE 6-24-2010; IN COMMERCE 6-24-2010.

THE MARK CONSISTS OF STANDARD CHARACTERS WITHOUT CLAIM TO ANY PARTICULAR FONT, STYLE, SIZE, OR COLOR.

FOR COMPUTER HARDWARE FOR PROCESSING NETWORK TRAFFIC (U.S. CLS. 21, 23, 26, 36 AND 38).

FIRST USE 1-21-2011; IN COMMERCE 1-21-2011.

3,941,112. SMARTERGO, INC., MORRIS PLAINS, NJ. SN 77-526,638. PUB. 6-2-2009, FILED 7-19-2008.

3,941,102. ANDRITZ AUTOMATION INC., ROSWELL, GA. SN 77-512,467. PUB. 11-25-2008, FILED 7-1-2008.

**SMART ERGO**



THE COLOR(S) YELLOW, BLUE AND RED IS/ARE CLAIMED AS A FEATURE OF THE MARK.

THE MARK CONSISTS OF THE WORD "BRAINWAVE" IN RED OVER TOP THE WORDS "SMART", "PRACTICAL" AND "PROVEN" IN RED, A BLUE OUTLINE OF A LIGHT-BULB DESIGN WITH YELLOW LIGHT STREAKS, AND, UNDER THE WORD "BRAINWAVE", A YELLOW HORIZONTAL LINE ENDING IN A ZIG ZAG.

FOR ELECTRICAL CONTROLLERS FOR PROCESS CONTROL (U.S. CLS. 21, 23, 26, 36 AND 38).

FIRST USE 5-0-2005; IN COMMERCE 5-0-2005.

THE MARK CONSISTS OF STANDARD CHARACTERS WITHOUT CLAIM TO ANY PARTICULAR FONT, STYLE, SIZE, OR COLOR.

NO CLAIM IS MADE TO THE EXCLUSIVE RIGHT TO USE "SMART", APART FROM THE MARK AS SHOWN.

THE ENGLISH TRANSLATION OF THE WORD "ERGO" IN THE MARK IS THEREFORE OR HENCE.

FOR COMPUTER SOFTWARE USED IN EVALUATING AND REMEDYING IMPROPER COMPUTER USAGE ERGONOMIC CONDITIONS (U.S. CLS. 21, 23, 26, 36 AND 38).

FIRST USE 1-10-2008; IN COMMERCE 6-1-2008.

**CLASS 9—(Continued).**

3,941,114. SANDISK CORPORATION, MILPITAS, CA. SN 77-529,262. PUB. 12-29-2009, FILED 7-23-2008.



NO CLAIM IS MADE TO THE EXCLUSIVE RIGHT TO USE THE PICTORIAL REPRESENTATION OF A MEMORY CARD, APART FROM THE MARK AS SHOWN.

THE MARK CONSISTS OF A MEMORY CARD WITH THE LETTERS "SM" AND A CARD SLOT.

FOR SEMICONDUCTOR MEMORY DEVICES, NAMELY, INTEGRATED CIRCUITS, ELECTRONIC CIRCUIT CARDS, BLANK MEMORY CARD CARTRIDGES; SEMICONDUCTOR DEVICES, NAMELY, FLASH MEMORY CARDS, MEMORY CARD CARTRIDGES, ADAPTERS, CONVERTERS, MEMORY CARD CONTROLLERS, MEDIA PLAYERS, MEMORY CARD READERS, STORAGE MODULES IN THE NATURE OF BLANK MEMORY CARDS, AND COMPUTER PERIPHERALS; PORTABLE AUDIO AND VIDEO PLAYERS AND RECORDERS WHICH USE SEMICONDUCTOR DEVICES AS RECORDING MEDIA; COMPUTER OPERATING PROGRAMS FOR SEMICONDUCTOR MEMORY DEVICES; AND PRERECORDED FLASH MEMORY CARDS FEATURING DIGITAL MULTIMEDIA CONTENT, NAMELY, MUSIC, MUSICAL VIDEOS, RELATED FILM CLIPS, INFORMATION ABOUT MUSIC AND MUSICIANS AND RING TONES; ACCESSORY PRODUCTS COMPATIBLE WITH DIGITAL AUDIO AND VIDEO PLAYERS WHICH MAY LEVERAGE A PHYSICAL ELECTRICAL AND MECHANICAL CONNECTION, NAMELY, PORTABLE AND NON-PORTABLE DOCKING STATIONS IN THE NATURE OF ADAPTERS TO CONNECT MEDIA PLAYERS TO AMPLIFIED SPEAKERS, RADIOS INCORPORATING CLOCKS, FM RADIO TRANSMITTERS; CAR STEREO DOCKING STATIONS IN THE NATURE OF ADAPTERS TO CONNECT MEDIA PLAYERS TO CAR STEREOS, WIRELESS AND WIRED HEADSETS FOR USE WITH DIGITAL AUDIO AND VIDEO PLAYERS, CASES FOR DIGITAL AUDIO AND VIDEO PLAYERS, AUDIO SPEAKERS, BATTERY CHARGERS, ADAPTERS FOR ATTACHING DIGITAL AUDIO AND VIDEO PLAYERS TO PERSONAL COMPUTERS AND PERIPHERALS, CONNECTION CABLES, SIGNAL SPLITTERS FOR ELECTRONIC APPARATUS, AND WIRELESS DONGLES IN THE NATURE OF WIRELESS NETWORK ADAPTERS FOR ELECTRONIC APPARATUS (U.S. CLS. 21, 23, 26, 36 AND 38).

FIRST USE 9-0-2008; IN COMMERCE 9-0-2008.

**CLASS 9—(Continued).**

3,941,132. ANGRY ROBOT LIMITED, OXFORD, UNITED KINGDOM. SN 77-567,890. PUB. 5-12-2009, FILED 9-11-2008.

**ANGRY ROBOT**

THE MARK CONSISTS OF STANDARD CHARACTERS WITHOUT CLAIM TO ANY PARTICULAR FONT, STYLE, SIZE, OR COLOR.

FOR AUDIO BOOKS IN THE FIELDS OF SCIENCE FICTION AND FANTASY; E-BOOKS IN THE FIELDS OF SCIENCE FICTION AND FANTASY THAT ARE DOWNLOADABLE FROM A GLOBAL COMPUTER NETWORK; PRE-RECORDED CDS AND DVDS IN THE FIELDS OF SCIENCE FICTION AND FANTASY (U.S. CLS. 21, 23, 26, 36 AND 38).

FIRST USE 1-16-2010; IN COMMERCE 8-31-2010.

3,941,138. GOOFY PRODUCTS, INC., HAPPY VALLEY, OR. SN 77-578,100. PUB. 7-28-2009, FILED 9-24-2008.

**GOOFY**

THE MARK CONSISTS OF STANDARD CHARACTERS WITHOUT CLAIM TO ANY PARTICULAR FONT, STYLE, SIZE, OR COLOR.

FOR ELECTRIC AND CABLE RACEWAYS (U.S. CLS. 21, 23, 26, 36 AND 38).

FIRST USE 10-28-2010; IN COMMERCE 10-28-2010.

**CLASS 9—(Continued).**

3,941,145. VALIDITY SENSORS, INC., SAN JOSE, CA. SN 77-589,721. PUB. 9-15-2009, FILED 10-9-2008.

**EASE OF USE, EASE OF MIND**

THE MARK CONSISTS OF STANDARD CHARACTERS WITHOUT CLAIM TO ANY PARTICULAR FONT, STYLE, SIZE, OR COLOR.

FOR BIOMETRIC SECURITY PRODUCTS, NAMELY, FINGERPRINT SENSOR HARDWARE AND SOFTWARE, USER MANUALS AND OTHER DOCUMENTATION SOLD AS A UNIT, NAMELY, FINGERPRINT SENSORS AND OTHER TYPES OF BIOMETRIC SENSORS SOLD AS SEPARATE PERIPHERAL DEVICES OR AS COMPONENT DEVICES TO BE INSTALLED IN AND/OR INTEGRATED IN OTHER DEVICES, NAMELY, LAPTOP AND DESKTOP COMPUTERS, MOBILE TELEPHONES, PERSONAL ELECTRONIC DEVICES, AND OTHER DEVICES TO PROVIDE BIOMETRIC AND FINGERPRINT IDENTIFICATION FOR ACCESS AUTHORIZATION SOLD AS A UNIT WITH DELIVERED PRODUCTS; FINGERPRINT AUTHENTICATION HARDWARE AND SOFTWARE FOR USE WITH INFORMATION, COMMUNICATION, AND ENTERTAINMENT DEVICES; AND HARDWARE AND SOFTWARE FOR ENABLING ACCESS TO PERSONAL INFORMATION, NAMELY, SOFTWARE AND HARDWARE FOR ENSURING THE SECURITY OF PERSONAL IDENTIFICATION AND AUTHORIZATION INFORMATION, BIOMETRIC INFORMATION INCLUDING FINGERPRINT DATA AND OTHER PERSONAL, COMPANY OR OTHER ENTITY IDENTIFICATION INFORMATION, DEVICE AND SYSTEM HARDWARE IDENTIFICATION INFORMATION (U.S. CLS. 21, 23, 26, 36 AND 38).

FIRST USE 1-7-2009; IN COMMERCE 1-22-2009.

3,941,157. IGT, RENO, NV. SN 77-605,806. PUB. 3-17-2009, FILED 11-3-2008.

**SCATTER BUCKS**

THE MARK CONSISTS OF STANDARD CHARACTERS WITHOUT CLAIM TO ANY PARTICULAR FONT, STYLE, SIZE, OR COLOR.

FOR GAMING MACHINES, NAMELY, DEVICES WHICH ACCEPT A WAGER (U.S. CLS. 21, 23, 26, 36 AND 38).

FIRST USE 1-28-2011; IN COMMERCE 1-28-2011.

**CLASS 9—(Continued).**

3,941,163. ALLSOP, INC., BELLINGHAM, WA. SN 77-614,597. PUB. 6-23-2009, FILED 11-14-2008.



THE MARK CONSISTS OF A CIRCLE WITH A PLUS SIGN AND UPWARDLY CURVED LINE APPEARING WITHIN.

FOR COMPUTER CARRYING CASES; PORTABLE COMPUTER STANDS SPECIFICALLY DESIGNED FOR LAPTOP COMPUTERS (U.S. CLS. 21, 23, 26, 36 AND 38).

FIRST USE 4-0-2009; IN COMMERCE 4-0-2009.

3,941,166. BUCK, ANTHONY A, COATESVILLE, PA. SN 77-619,909. PUB. 12-1-2009, FILED 11-21-2008.

**Map of a Human Being**

THE MARK CONSISTS OF STANDARD CHARACTERS WITHOUT CLAIM TO ANY PARTICULAR FONT, STYLE, SIZE, OR COLOR.

FOR DOWNLOADABLE AUDIO FILES, TEXT FILES, EMAILS, WRITTEN DOCUMENTS, AUDIO MATERIAL, VIDEO MATERIAL IN THE FIELD OF SELF-HELP EDUCATION (U.S. CLS. 21, 23, 26, 36 AND 38).

FIRST USE 10-30-2005; IN COMMERCE 8-7-2009.

3,941,172. COOL ENERGY, INC., BOULDER, CO. SN 77-631,112. PUB. 4-21-2009, FILED 12-11-2008.

**SolarFlow**

THE MARK CONSISTS OF STANDARD CHARACTERS WITHOUT CLAIM TO ANY PARTICULAR FONT, STYLE, SIZE, OR COLOR.

FOR APPARATUS FOR CONVERTING SOLAR THERMAL ENERGY TO ELECTRICAL ENERGY (U.S. CLS. 21, 23, 26, 36 AND 38).

FIRST USE 1-10-2007; IN COMMERCE 12-10-2010.

**CLASS 9—(Continued).**

3,941,188. SONY CORPORATION, TOKYO, JAPAN. SN 77-643,099. PUB. 12-1-2009, FILED 1-5-2009.

# DVCAM

THE MARK CONSISTS OF STANDARD CHARACTERS WITHOUT CLAIM TO ANY PARTICULAR FONT, STYLE, SIZE, OR COLOR.

FOR VIDEO TAPE PLAYERS AND/OR RECORDERS; VIDEO CAMERAS; BLANK MAGNETIC TAPES (U.S. CLS. 21, 23, 26, 36 AND 38).

FIRST USE 10-31-2006; IN COMMERCE 10-31-2006.

3,941,226. HY-KO PRODUCTS COMPANY, NORTHFIELD, OH. SN 77-672,675. PUB. 12-22-2009, FILED 2-18-2009.

# I-KEY

THE MARK CONSISTS OF STANDARD CHARACTERS WITHOUT CLAIM TO ANY PARTICULAR FONT, STYLE, SIZE, OR COLOR.

FOR TRANSPONDER KEYS (U.S. CLS. 21, 23, 26, 36 AND 38).

FIRST USE 9-30-2006; IN COMMERCE 9-30-2006.

3,941,237. EMC CORPORATION, HOPKINTON, MA. SN 77-685,601. PUB. 11-24-2009, FILED 3-6-2009.

# VBLOCK

THE MARK CONSISTS OF STANDARD CHARACTERS WITHOUT CLAIM TO ANY PARTICULAR FONT, STYLE, SIZE, OR COLOR.

FOR COMPUTER HARDWARE; COMPUTE SERVERS; STORAGE SERVERS; NETWORKING SERVERS; COMPUTER HARDWARE AND SOFTWARE, NAMELY, DATA STORAGE AND RETRIEVAL APPARATUS, COMPRISING PROCESSORS, NETWORKS, MEMORIES, OPERATING SOFTWARE AND DATA STORAGE UNITS; COMPUTER SOFTWARE FOR DATA MANAGEMENT, DATA STORAGE, NETWORKING AND VIRTUALIZATION (U.S. CLS. 21, 23, 26, 36 AND 38).

FIRST USE 11-3-2009; IN COMMERCE 11-3-2009.

**CLASS 9—(Continued).**

3,941,241. PUBCOMPANY S.R.L., ALBIGNASEGO (PD), ITALY. SN 77-694,712. PUB. 10-13-2009, FILED 3-19-2009.

# 3i

THE MARK CONSISTS OF STANDARD CHARACTERS WITHOUT CLAIM TO ANY PARTICULAR FONT, STYLE, SIZE, OR COLOR.

FOR VIDEO GAME SOFTWARE, AND HARDWARE INPUT DEVICES, NAMELY, HARDWARE DEVICES ALLOWING USERS TO CONTROL A VIDEO GAME USING NONCONVENTIONAL INPUT TECHNIQUES INCLUDING BODY MOVEMENT AND/OR MENTAL CONTROL, AND SOFTWARE FOR CONTROL THEREOF (U.S. CLS. 21, 23, 26, 36 AND 38).

FIRST USE 12-27-2010; IN COMMERCE 12-27-2010.

3,941,250. KIRKHOUSE PRODUCTIONS, LLC, AUSTIN, TX. SN 77-709,805. PUB. 11-10-2009, FILED 4-8-2009.

# NEMESYNTH

THE MARK CONSISTS OF STANDARD CHARACTERS WITHOUT CLAIM TO ANY PARTICULAR FONT, STYLE, SIZE, OR COLOR.

FOR COMPUTER HARDWARE AND SOFTWARE FOR PROCESSING DIGITAL MUSIC FILES (U.S. CLS. 21, 23, 26, 36 AND 38).

FIRST USE 9-6-2010; IN COMMERCE 10-1-2010.

3,941,255. PHOENIX WIRELESS, INC., HATFIELD, PA. SN 77-717,833. PUB. 12-1-2009, FILED 4-20-2009.

# ECOLIFE

THE MARK CONSISTS OF STANDARD CHARACTERS WITHOUT CLAIM TO ANY PARTICULAR FONT, STYLE, SIZE, OR COLOR.

FOR CELLULAR TELEPHONE ACCESSORIES, NAMELY, CARRYING CASES, CHARGERS, PHONE SHIELDS AND PHONE SKINS (U.S. CLS. 21, 23, 26, 36 AND 38).

FIRST USE 6-0-2009; IN COMMERCE 6-0-2009.



**CLASS 9—(Continued).**

3,941,256. KAIPARASOFT LIMITED, KUMEU, AUCKLAND, NEW ZEALAND. SN 77-720,693. PUB. 2-16-2010, FILED 4-23-2009.

**NINJA KIWI**

THE MARK CONSISTS OF STANDARD CHARACTERS WITHOUT CLAIM TO ANY PARTICULAR FONT, STYLE, SIZE, OR COLOR.

FOR VIDEO GAME SOFTWARE; COMPUTER GAME SOFTWARE; VIDEO GAME PROGRAMS; COMPUTER GAME PROGRAMS; ELECTRONIC GAME PROGRAMS FOR HOME GAME MACHINES; ELECTRONIC GAME PROGRAMS FOR HAND-HELD MACHINES; ELECTRONIC GAME PROGRAMS FOR MOBILE TELEPHONES; DOWNLOADABLE COMPUTER GAME PROGRAMS; VIDEO GAME DISCS, CARTRIDGES AND CASSETTES (U.S. CLS. 21, 23, 26, 36 AND 38).

FIRST USE 1-0-2007; IN COMMERCE 1-0-2007.

---

3,941,305. ACCESS INNOVATIONS, INC., ALBUQUERQUE, NM. SN 77-759,951. PUB. 6-1-2010, FILED 6-15-2009.

**WEBTHES**

THE MARK CONSISTS OF STANDARD CHARACTERS WITHOUT CLAIM TO ANY PARTICULAR FONT, STYLE, SIZE, OR COLOR.

FOR COMPUTER SOFTWARE, NAMELY, SOFTWARE THAT PROVIDES AN INTERNET BROWSER USER INTERFACE FOR OTHER COMPUTER PROGRAMS (U.S. CLS. 21, 23, 26, 36 AND 38).

FIRST USE 2-16-2010; IN COMMERCE 5-13-2010.

---

3,941,330. NOUVEAU EYEWEAR, INC., CARROLLTON, TX. SN 77-769,441. PUB. 11-17-2009, FILED 6-26-2009.

**JACKSON PERRY**

THE MARK CONSISTS OF STANDARD CHARACTERS WITHOUT CLAIM TO ANY PARTICULAR FONT, STYLE, SIZE, OR COLOR.

THE NAME "JACKSON PERRY" IDENTIFIES A LIVING INDIVIDUAL WHOSE CONSENT IS OF RECORD.

FOR OPHTHALMIC FRAMES, FASHION EYEWEAR AND SUNGLASSES (U.S. CLS. 21, 23, 26, 36 AND 38).

FIRST USE 12-11-2009; IN COMMERCE 12-11-2009.

**CLASS 9—(Continued).**

3,941,345. ATLAS SOUND LP, ENNIS, TX. SN 77-773,567. PUB. 12-15-2009, FILED 7-2-2009.

**Atlas Technologies**

THE MARK CONSISTS OF STANDARD CHARACTERS WITHOUT CLAIM TO ANY PARTICULAR FONT, STYLE, SIZE, OR COLOR.

OWNER OF U.S. REG. NO. 2,573,786.

NO CLAIM IS MADE TO THE EXCLUSIVE RIGHT TO USE "TECHNOLOGIES", APART FROM THE MARK AS SHOWN.

FOR AUDIO EQUIPMENT, NAMELY, LOUDSPEAKERS, INTERCOMS, SIRENS, HORNS, EMERGENCY COMMUNICATION SYSTEMS COMPRISED OF TWO-WAY TELEPHONE SYSTEMS AND INTERCOMS; COMPRESSION DRIVERS, ACOUSTIC BAFFLES, ATTENUATORS, REPEATERS, POWER SUPPLIES, LOUDSPEAKER CABINETS, SPEAKER GRILLES AND FRAMES, WALL-MOUNTED VOLUME CONTROLS FOR AUDIO SYSTEMS, SOUND MASKING SPEAKERS AND GENERATORS, MICROPHONE AND STUDIO BOOM STANDS, ACCESSORIES FOR MICROPHONE AND STUDIO BOOM STANDS, NAMELY, CLIPS, EXTENSIONS, FLANGES, CLAMPS, CABLE AND TAMBOURINE HANGERS, CABLE FEED-THROUGH ADAPTERS, SURFACE MOUNTING FIXTURES, COUPLINGS FOR USE WITH TUBE EXTENSIONS, HANGERS AND REPLACEMENT PARTS, AND RACKS, CABINETS, AND CONSOLES FOR AUDIO EQUIPMENT (U.S. CLS. 21, 23, 26, 36 AND 38).

FIRST USE 6-15-2009; IN COMMERCE 6-15-2009.

---

3,941,375. TWELVE SOUTH, LLC, MOUNT PLEASANT, SC. SN 77-785,221. PUB. 12-7-2010, FILED 7-20-2009.

**SURFACEPAD**

THE MARK CONSISTS OF STANDARD CHARACTERS WITHOUT CLAIM TO ANY PARTICULAR FONT, STYLE, SIZE, OR COLOR.

FOR COMPUTER ACCESSORIES, NAMELY, PROTECTIVE COVERS FOR ADHERING TO A COMPUTER (U.S. CLS. 21, 23, 26, 36 AND 38).

FIRST USE 12-31-2009; IN COMMERCE 12-31-2009.

**CLASS 9—(Continued).**

3,941,378. GOOD WAY INTERNATIONAL LIMITED, QUARRY BAY, HONG KONG. SN 77-785,958. PUB. 12-15-2009, FILED 7-21-2009.

## PROGEAR

THE MARK CONSISTS OF STANDARD CHARACTERS WITHOUT CLAIM TO ANY PARTICULAR FONT, STYLE, SIZE, OR COLOR.

FOR OPTICAL PRODUCTS FOR USE IN SPORTS, NAMELY, SPECTACLES, SUNGLASSES AND LENSES (U.S. CLS. 21, 23, 26, 36 AND 38).

FIRST USE 1-25-2011; IN COMMERCE 1-25-2011.

3,941,379. UMG RECORDINGS, INC., SANTA MONICA, CA. SN 77-786,293. PUB. 6-8-2010, FILED 7-21-2009.

## MACHETE MUSIC

THE MARK CONSISTS OF STANDARD CHARACTERS WITHOUT CLAIM TO ANY PARTICULAR FONT, STYLE, SIZE, OR COLOR.

NO CLAIM IS MADE TO THE EXCLUSIVE RIGHT TO USE "MUSIC", APART FROM THE MARK AS SHOWN.

FOR PRE-RECORDED AUDIO TAPES, DISCS AND CASSETTES, VIDEO TAPES, DISCS AND CASSETTES, DIGITAL AUDIO AND AUDIO VIDEO TAPES AND DISCS, CDS, DVDS, LASER DISCS, AND PHONOGRAPH RECORDS FEATURING MUSIC AND ENTERTAINMENT; THEATRICAL AND MUSICAL SOUND AND VIDEO RECORDINGS; VIRTUAL REALITY GAME SOFTWARE; DOWNLOADABLE RING TONES, MUSIC, MP3 FILES FEATURING MUSIC, GRAPHICS, GAMES, IMAGES AND VIDEOS FOR WIRELESS COMMUNICATION DEVICES; DOWNLOADABLE MUSIC, MP3 FILES FEATURING MUSIC, GRAPHICS, COMPUTER GAMES, IMAGES AND VIDEOS; COMPUTER GAME SOFTWARE, TAPES, CARTRIDGES AND CASSETTES; VIDEO GAME SOFTWARE, TAPES, CARTRIDGES AND CASSETTES; AND MOUSE PADS (U.S. CLS. 21, 23, 26, 36 AND 38).

FIRST USE 2-1-2006; IN COMMERCE 2-1-2006.

**CLASS 9—(Continued).**

3,941,394. ROBERT J. THOMPSON, DBA RETRO DELUXE, BOWIE, MD. SN 77-794,886. PUB. 6-8-2010, FILED 7-31-2009.

## Retro Deluxe

THE MARK CONSISTS OF STANDARD CHARACTERS WITHOUT CLAIM TO ANY PARTICULAR FONT, STYLE, SIZE, OR COLOR.

NO CLAIM IS MADE TO THE EXCLUSIVE RIGHT TO USE "RETRO", APART FROM THE MARK AS SHOWN.

FOR MUSICAL SOUND RECORDINGS, NAMELY, ELECTRONIC FILES, COMPACT DISCS, PRE-RECORDED AUDIO TAPES AND PHONOGRAPH RECORDS (U.S. CLS. 21, 23, 26, 36 AND 38).

FIRST USE 1-20-2009; IN COMMERCE 8-23-2009.

3,941,422. PANASONIC CORPORATION OF NORTH AMERICA, SECAUCUS, NJ. SN 77-803,069. PUB. 11-3-2009, FILED 8-12-2009.

## LITE-RAY

THE MARK CONSISTS OF STANDARD CHARACTERS WITHOUT CLAIM TO ANY PARTICULAR FONT, STYLE, SIZE, OR COLOR.

OWNER OF U.S. REG. NO. 3,459,233.

FOR ELECTRONIC CASH REGISTERS (U.S. CLS. 21, 23, 26, 36 AND 38).

FIRST USE 9-1-2010; IN COMMERCE 9-1-2010.

3,941,443. JOHNSON OUTDOORS MARINE ELECTRONICS, INC., EUFAULA, AL. SN 77-816,243. PUB. 6-15-2010, FILED 8-31-2009.

## DOWN IMAGING

THE MARK CONSISTS OF STANDARD CHARACTERS WITHOUT CLAIM TO ANY PARTICULAR FONT, STYLE, SIZE, OR COLOR.

NO CLAIM IS MADE TO THE EXCLUSIVE RIGHT TO USE "IMAGING", APART FROM THE MARK AS SHOWN.

FOR SONAR EQUIPMENT AND PARTS THEREOF, AND SONAR FEATURE FOR FISH FINDERS, NAMELY, MARINE ELECTRONIC APPARATUS USED FOR NAVIGATION, FISHING, AND SEARCH/RECOVERY, NAMELY, MARINE DEPTH FINDERS AND COMPUTER HARDWARE, SOFTWARE AND DISPLAYS, ALL FOR SONAR (U.S. CLS. 21, 23, 26, 36 AND 38).

FIRST USE 3-31-2010; IN COMMERCE 3-31-2010.

**CLASS 9—(Continued).**

3,941,444. FTEN, INC., NEW YORK, NY. SN 77-816,251. PUB. 12-15-2009, FILED 8-31-2009.

# DRX

THE MARK CONSISTS OF STANDARD CHARACTERS WITHOUT CLAIM TO ANY PARTICULAR FONT, STYLE, SIZE, OR COLOR.

FOR SOFTWARE FOR USE IN HIGH SPEED, LOW LATENCY FINANCIAL SECURITIES TRADING, NAMELY, FOR REAL TIME PROCESSING OF SECURITY TRADE REQUESTS WITH AVAILABLE, CONFIGURABLE RISK MANAGEMENT PARAMETERS (U.S. CLS. 21, 23, 26, 36 AND 38).

FIRST USE 6-1-2010; IN COMMERCE 6-1-2010.

3,941,449. LENCO MARINE, INC., STUART, FL. SN 77-819,498. PUB. 2-2-2010, FILED 9-3-2009.

# AUTO GLIDE

THE MARK CONSISTS OF STANDARD CHARACTERS WITHOUT CLAIM TO ANY PARTICULAR FONT, STYLE, SIZE, OR COLOR.

FOR MARINE VEHICLE ELECTRIC PROPULSION CONTROLLER FOR SPEED AND DIRECTION (U.S. CLS. 21, 23, 26, 36 AND 38).

FIRST USE 3-25-2010; IN COMMERCE 3-25-2010.

3,941,471. THEOS MEDICAL SYSTEMS INC., DBA MY-CHUMMIE.COM, SANTA CLARA, CA. SN 77-832,610. PUB. 2-16-2010, FILED 9-22-2009.

# CHUMMIE

FOR ELECTRONIC ALARM FOR PROVIDING NOTICE OF BED-WETTING (U.S. CLS. 21, 23, 26, 36 AND 38).

FIRST USE 3-15-2010; IN COMMERCE 5-24-2010.

**CLASS 9—(Continued).**

3,941,476. ARCANANETWORKS, INC., NEWARK, CA. SN 77-835,536. PUB. 2-16-2010, FILED 9-25-2009.

# ibizvoice

THE MARK CONSISTS OF STANDARD CHARACTERS WITHOUT CLAIM TO ANY PARTICULAR FONT, STYLE, SIZE, OR COLOR.

FOR COMPUTER SOFTWARE THAT PROVIDES WEB-BASED ACCESS TO APPLICATIONS AND SERVICES THROUGH A WEB OPERATING SYSTEM OR PORTAL INTERFACE (U.S. CLS. 21, 23, 26, 36 AND 38).

FIRST USE 2-1-2010; IN COMMERCE 2-1-2010.

3,941,478. HONG, WAN KI, SEOUL, REPUBLIC OF KOREA. SN 77-836,880. PUB. 8-24-2010, FILED 9-29-2009.

# HJC

THE MARK CONSISTS OF STANDARD CHARACTERS WITHOUT CLAIM TO ANY PARTICULAR FONT, STYLE, SIZE, OR COLOR.

OWNER OF U.S. REG. NOS. 3,224,785 AND 3,475,242. FOR SAFETY PRODUCTS, NAMELY, PROTECTIVE HELMETS, MOTORCYCLE HELMETS, AUTO-RACING HELMETS, SNOWMOBILE HELMETS, BICYCLE HELMETS (U.S. CLS. 21, 23, 26, 36 AND 38).

FIRST USE 1-1-1986; IN COMMERCE 1-1-1986.

3,941,492. ATLANTIC DIVING SUPPLY, INC., VIRGINIA BEACH, VA. SN 77-846,698. PUB. 8-3-2010, FILED 10-12-2009.



NO CLAIM IS MADE TO THE EXCLUSIVE RIGHT TO USE "FIRE RESISTANT" AND "ENVIRONMENTAL ENSEMBLE", APART FROM THE MARK AS SHOWN.

**CLASS 9—(Continued).**

THE MARK CONSISTS OF THE STYLIZED WORDING "FIRE RESISTANT" OVER "FREE" IN LARGER PRINT OVER "ENVIRONMENTAL ENSEMBLE," WITH FLAME DESIGNS BOTH OVER AND UNDERNEATH THE WORDING.

FOR CLOTHING FOR PROTECTION AGAINST FIRE, NAMELY, FIRE RESISTANT AND FIRE RETARDANT APPAREL IN THE NATURE OF TOPS, BOTTOMS, GLOVES, SOCKS, AND BELTS INTENDED FOR MILITARY AND LAW ENFORCEMENT PERSONNEL (U.S. CLS. 21, 23, 26, 36 AND 38).

FIRST USE 7-31-2007; IN COMMERCE 7-31-2007.

---

3,941,501. ZHAO, ZHONG SHI, JIANGSU PROVINCE, CHINA. SN 77-851,491. PUB. 6-1-2010, FILED 10-19-2009.

**PRCEMETER**

THE MARK CONSISTS OF STANDARD CHARACTERS WITHOUT CLAIM TO ANY PARTICULAR FONT, STYLE, SIZE, OR COLOR.

FOR COMPUTERS; MEASURING INSTRUMENTS, NAMELY, CONDUCTIVITY METERS; GEIGER COUNTERS; ELECTRIC COUNTERS FOR COUNTING COINS; AIR QUALITY MEASUREMENT APPARATUS, NAMELY, PARTICLE COUNTERS; TRANSFORMERS; ELECTRICAL TRANSFORMERS; COMMUTATORS; INVERTERS; POWER INVERTERS; JUNCTION BOXES; ELECTRIC JUNCTION BOXES; ELECTRIC JUNCTION BOX HOUSINGS; ELECTRICAL DISTRIBUTION BOXES; ELECTRICAL DISTRIBUTION BOXES; PROXIMITY SENSORS; ELECTRONIC DATA RELAYS FOR SENSORS; VOLTAGE REGULATORS (U.S. CLS. 21, 23, 26, 36 AND 38).

FIRST USE 9-1-2009; IN COMMERCE 10-31-2009.

---

3,941,512. GS BATTERY (U.S.A.) INC., ROSWELL, GA. SN 77-856,333. PUB. 4-27-2010, FILED 10-23-2009.

**ECO R**

THE MARK CONSISTS OF STANDARD CHARACTERS WITHOUT CLAIM TO ANY PARTICULAR FONT, STYLE, SIZE, OR COLOR.

NO CLAIM IS MADE TO THE EXCLUSIVE RIGHT TO USE "ECO", APART FROM THE MARK AS SHOWN.

FOR BATTERIES, NAMELY, BATTERIES FOR LIGHTING, ELECTRIC BATTERIES, ELECTRIC STORAGE BATTERIES, RECHARGEABLE ELECTRIC BATTERIES, SOLAR BATTERIES; BATTERY CHARGERS; BATTERY PACKS; RENEWABLE BATTERY SYSTEM TO PROVIDE BACKUP POWER; INVERTERS FOR THE CONVERSION OF ENERGY IN A SOLAR OR WIND APPLICATION (U.S. CLS. 21, 23, 26, 36 AND 38).

FIRST USE 9-0-2009; IN COMMERCE 9-0-2009.

**CLASS 9—(Continued).**

3,941,517. AT&T INTELLECTUAL PROPERTY II, L.P., RENO, NV. SN 77-857,411. PUB. 5-25-2010, FILED 10-26-2009.

**AT&T WORKBENCH**

THE MARK CONSISTS OF STANDARD CHARACTERS WITHOUT CLAIM TO ANY PARTICULAR FONT, STYLE, SIZE, OR COLOR.

OWNER OF U.S. REG. NOS. 1,296,936, 1,970,579, AND OTHERS.

NO CLAIM IS MADE TO THE EXCLUSIVE RIGHT TO USE "WORKBENCH", APART FROM THE MARK AS SHOWN.

FOR COMPUTER APPLICATION SOFTWARE FOR MOBILE PHONES (U.S. CLS. 21, 23, 26, 36 AND 38).

FIRST USE 3-23-2010; IN COMMERCE 3-23-2010.

---

3,941,548. GL SUITE, INC., BEND, OR. SN 77-868,616. PUB. 4-20-2010, FILED 11-9-2009.



OWNER OF U.S. REG. NO. 2,511,493.

NO CLAIM IS MADE TO THE EXCLUSIVE RIGHT TO USE "SUITE", APART FROM THE MARK AS SHOWN.

THE MARK CONSISTS OF THE TERM "GL SUITE" AND CIRCULAR DESIGN.

FOR COMPUTER SOFTWARE USED TO MANAGE THE REGULATORY OPERATIONS, CREATE BEST PRACTICE SOLUTIONS, PROVIDE REGULATORY AND CASE MANAGEMENT, AND MANAGE ON-LINE REGULATORY RENEWALS FOR GOVERNMENT, FOR-PROFIT COMPANIES, NOT-FOR-PROFIT ENTITIES AND EDUCATIONAL ENTITIES THAT ISSUE CERTIFICATIONS, LICENSES AND REGISTRATIONS (U.S. CLS. 21, 23, 26, 36 AND 38).

FIRST USE 3-19-2010; IN COMMERCE 3-19-2010.

---

3,941,563. SHUFFLE MASTER, INC., LAS VEGAS, NV. SN 77-872,587. PUB. 10-19-2010, FILED 11-13-2009.

**MISSISSIPPI STUD**

THE MARK CONSISTS OF STANDARD CHARACTERS WITHOUT CLAIM TO ANY PARTICULAR FONT, STYLE, SIZE, OR COLOR.

OWNER OF U.S. REG. NO. 3,341,291.

**CLASS 9—(Continued).**

NO CLAIM IS MADE TO THE EXCLUSIVE RIGHT TO USE "STUD", APART FROM THE MARK AS SHOWN.

FOR STAND ALONE, MULTIPLE PLAYER, INTERACTIVE GAMING MACHINES WITH VIDEO OUTPUT (U.S. CLS. 21, 23, 26, 36 AND 38).

FIRST USE 11-17-2010; IN COMMERCE 11-17-2010.

---

3,941,565. SUNRISE TELECOM INCORPORATED, SAN JOSE, CA. SN 77-873,808. PUB. 10-19-2010, FILED 11-16-2009.

**RXT**

THE MARK CONSISTS OF STANDARD CHARACTERS WITHOUT CLAIM TO ANY PARTICULAR FONT, STYLE, SIZE, OR COLOR.

FOR ELECTRONIC TELECOMMUNICATIONS AND DATA COMMUNICATIONS TESTING EQUIPMENT, NAMELY, HAND-HELD PORTABLE AND RACK MOUNTED TESTING EQUIPMENT, COMPUTER SOFTWARE FOR USE THEREWITH, AND MANUALS SOLD THEREWITH AS A UNIT (U.S. CLS. 21, 23, 26, 36 AND 38).

FIRST USE 12-17-2010; IN COMMERCE 12-17-2010.

---

3,941,601. TOSH AVIATION, INC., CHATTANOOGA, TN. SN 77-882,117. PUB. 6-15-2010, FILED 11-30-2009.

**e▲handle**

THE MARK CONSISTS OF THE LETTER "E" FOLLOWED BY A TRIANGLE FOLLOWED BY THE WORD "HANDLE".

FOR PROGRAMMABLE ELECTRONIC LUGGAGE TAGS WITH LED DISPLAY; COMPUTER HARDWARE AND SOFTWARE FOR RECORDING AND DISPLAYING PERSONAL FLIGHT AND BAGGAGE INFORMATION (U.S. CLS. 21, 23, 26, 36 AND 38).

FIRST USE 12-30-2010; IN COMMERCE 12-30-2010.

**CLASS 9—(Continued).**

3,941,604. DEVICEFIDELITY, INC., RICHARDSON, TX. SN 77-882,409. PUB. 6-1-2010, FILED 11-30-2009.

**IN2PAY**

THE MARK CONSISTS OF STANDARD CHARACTERS WITHOUT CLAIM TO ANY PARTICULAR FONT, STYLE, SIZE, OR COLOR.

FOR COMPUTER HARDWARE AND COMPUTER SOFTWARE, NAMELY, ELECTRONIC FINANCIAL PLATFORM THAT ACCOMMODATES MULTIPLE TYPES OF PAYMENT TRANSACTIONS IN A MOBILE DEVICE (U.S. CLS. 21, 23, 26, 36 AND 38).

FIRST USE 7-28-2010; IN COMMERCE 7-28-2010.

---

3,941,623. OPTEX CO., LTD., OTSU-SHI, SHIGA, JAPAN. SN 77-889,292. PUB. 4-20-2010, FILED 12-9-2009.

**REDSKAN**

THE MARK CONSISTS OF STANDARD CHARACTERS WITHOUT CLAIM TO ANY PARTICULAR FONT, STYLE, SIZE, OR COLOR.

FOR INTRUDER MOTION DETECTORS, NAMELY, LASER, PASSIVE INFRARED, PHOTO ELECTRIC, MICROWAVE AND THEIR COMBINATION DETECTORS; CAMERAS; DIGITAL VIDEO CAMERAS; ANALOGUE VIDEO CAMERAS; DIGITAL CAMERAS; VIDEO CASSETTE RECORDERS; VIDEO RECORDERS; DIGITAL VIDEO RECORDERS; DIGITAL EVENT RECORDERS; BURGLAR ALARM SYSTEMS AND REMOTE SURVEILLANCE SYSTEMS COMPRISED OF DIGITAL VIDEO CAMERAS, ANALOGUE VIDEO CAMERAS, DIGITAL CAMERAS, VIDEO CASSETTE RECORDERS, VIDEO RECORDERS, DIGITAL VIDEO RECORDERS, DIGITAL EVENT RECORDERS AND INTRUDER MOTION DETECTORS; CONTROL DEVICES AND COMPUTER PERIPHERALS THAT GENERATE ALARMS FROM INTRUSION DETECTION SIGNALS AND VIDEO SIGNALS; TRANSMISSION DEVICES AND PERIPHERALS THAT SEND/RECEIVE ALARMS, INTRUSION DETECTION SIGNALS AND VIDEO SIGNALS, NAMELY, RADIO RECEIVERS AND TRANSMITTERS, AND SATELLITE RECEIVERS AND TRANSMITTERS (U.S. CLS. 21, 23, 26, 36 AND 38).

FIRST USE 2-14-2009; IN COMMERCE 2-14-2009.

**CLASS 9—(Continued).**

3,941,633. MONSTER CABLE PRODUCTS, INC., BRISBANE, CA. SN 77-891,939. PUB. 4-6-2010, FILED 12-11-2009.

# JAMMIN

THE MARK CONSISTS OF STANDARD CHARACTERS WITHOUT CLAIM TO ANY PARTICULAR FONT, STYLE, SIZE, OR COLOR.

FOR HEADPHONES (U.S. CLS. 21, 23, 26, 36 AND 38). FIRST USE 6-29-2009; IN COMMERCE 6-29-2009.

---

3,941,645. SURETINT SYSTEMS, LLC, NORTHBROOK, IL. SN 77-894,376. PUB. 5-18-2010, FILED 12-16-2009.

## COMPLETE COLOR CONTROL

THE MARK CONSISTS OF STANDARD CHARACTERS WITHOUT CLAIM TO ANY PARTICULAR FONT, STYLE, SIZE, OR COLOR.

NO CLAIM IS MADE TO THE EXCLUSIVE RIGHT TO USE "COLOR CONTROL", APART FROM THE MARK AS SHOWN.

FOR COMPUTER HARDWARE AND SOFTWARE SOLD TOGETHER AS A UNIT FOR THE COLOR FORMULATION OF DYES, COLORS, PAINTS, HAIR DYE, AND PERSONAL CARE PRODUCTS (U.S. CLS. 21, 23, 26, 36 AND 38).

FIRST USE 1-10-2011; IN COMMERCE 1-10-2011.

---

3,941,648. ETI SOUND SYSTEMS, INC., HUNTINGTON PARK, CA. SN 77-894,485. PUB. 5-11-2010, FILED 12-16-2009.

# VENGEANCE

THE MARK CONSISTS OF STANDARD CHARACTERS WITHOUT CLAIM TO ANY PARTICULAR FONT, STYLE, SIZE, OR COLOR.

FOR AMPLIFIERS; AUDIO AMPLIFIERS (U.S. CLS. 21, 23, 26, 36 AND 38). FIRST USE 1-3-2011; IN COMMERCE 1-3-2011.

**CLASS 9—(Continued).**

3,941,658. PROCON FLEET SERVICES, LLC, KNOXVILLE, TN. SN 77-895,475. PUB. 5-11-2010, FILED 12-17-2009.



OWNER OF U.S. REG. NOS. 3,487,073 AND 3,494,645. THE COLOR(S) RED AND BLACK IS/ARE CLAIMED AS A FEATURE OF THE MARK.

THE MARK CONSISTS OF THE WORD "SATTRACK" IN STYLIZED BLOCK LETTERS, WHEREIN THE LETTERS "SAT" ARE IN RED AND THE LETTERS "TRACK" ARE IN BLACK, AND THREE CONCENTRIC RED ARCS EMANATING OUTWARD FROM THE UPPER RIGHT PORTION OF THE LETTER K.

FOR WIRELESS DEVICES FOR NAVIGATION, COMMUNICATION AND TRACKING, NAMELY, PORTABLE TRACKING UNITS THAT COMBINE GPS AND CELLULAR TECHNOLOGIES FOR DETERMINING LOCATION INFORMATION AND COMMUNICATING THE LOCATION INFORMATION (U.S. CLS. 21, 23, 26, 36 AND 38). FIRST USE 2-10-2010; IN COMMERCE 2-10-2010.

---

3,941,659. DANIEL J. ZEHNDER, NEW BERLIN, WI. SN 77-895,528. PUB. 5-25-2010, FILED 12-17-2009.

## MEASURE MATE

THE MARK CONSISTS OF STANDARD CHARACTERS WITHOUT CLAIM TO ANY PARTICULAR FONT, STYLE, SIZE, OR COLOR.

NO CLAIM IS MADE TO THE EXCLUSIVE RIGHT TO USE "MEASURE", APART FROM THE MARK AS SHOWN.

FOR A PLATE WITH A PLURALITY OF NUTS AND BOLTS ATTACHED THERETO FOR MEASURING THE SIZE OF FASTENER THREADS, NAMELY, BOLTS, SCREWS, STUDS AND NUTS (U.S. CLS. 21, 23, 26, 36 AND 38).

FIRST USE 12-29-2010; IN COMMERCE 12-29-2010.

**CLASS 9—(Continued).**

3,941,680. NAMCO BANDAI GAMES AMERICA INC., SANTA CLARA, CA. SN 77-898,560. PUB. 5-18-2010, FILED 12-21-2009.

**ODYSSEY TO THE WEST**

THE MARK CONSISTS OF STANDARD CHARACTERS WITHOUT CLAIM TO ANY PARTICULAR FONT, STYLE, SIZE, OR COLOR.

FOR COMPUTER GAME PROGRAMS; COMPUTER GAME SOFTWARE; DOWNLOADABLE COMPUTER GAME SOFTWARE; VIDEO GAME DISCS; AND VIDEO GAME SOFTWARE (U.S. CLS. 21, 23, 26, 36 AND 38).

FIRST USE 10-5-2010; IN COMMERCE 10-5-2010.

---

3,941,714. REVENUE FRONTIER, LLC, SANTA MONICA, CA. SN 77-903,677. PUB. 5-18-2010, FILED 12-31-2009.

**BOOM-A-RING**

THE MARK CONSISTS OF STANDARD CHARACTERS WITHOUT CLAIM TO ANY PARTICULAR FONT, STYLE, SIZE, OR COLOR.

FOR A CELL PHONE ACCESSORY, NAMELY, A TELEPHONE HANDSET THAT PLUGS INTO THE CELL PHONE (U.S. CLS. 21, 23, 26, 36 AND 38).

FIRST USE 4-26-2010; IN COMMERCE 4-26-2010.

---

3,941,716. QNOMY INC, NEW YORK, NY. SN 77-904,113. PUB. 6-15-2010, FILED 1-4-2010.

**V-FLOW**

THE MARK CONSISTS OF STANDARD CHARACTERS WITHOUT CLAIM TO ANY PARTICULAR FONT, STYLE, SIZE, OR COLOR.

FOR COMPUTER SOFTWARE FOR DISTRIBUTION, PRESENTATION, INTEGRATION AND MANAGEMENT OF DIGITAL MEDIA FILES (U.S. CLS. 21, 23, 26, 36 AND 38).

FIRST USE 3-1-2010; IN COMMERCE 3-1-2010.

**CLASS 9—(Continued).**

3,941,732. PANAMEDIA GROUP, LLC, ST. LOUIS, MO. SN 77-907,574. PUB. 6-15-2010, FILED 1-8-2010.

**BELINKER**

THE MARK CONSISTS OF STANDARD CHARACTERS WITHOUT CLAIM TO ANY PARTICULAR FONT, STYLE, SIZE, OR COLOR.

FOR PORTABLE WIRELESS ELECTRONIC DEVICES, NAMELY, WIRELESS COMMUNICATION DEVICES FOR DATA TRANSMISSION FOR USE BY EVENT ATTENDEES, VENDORS AND EVENT ORGANIZERS DURING AN EVENT COMPRISING COMPUTER SOFTWARE AND HARDWARE FOR MANAGING THE FLOW OF EVENT-SPECIFIC ELECTRONIC INFORMATION AND FOR FACILITATING EFFECTIVE COMMUNICATION AMONG EVENT ATTENDEES, VENDORS AND EVENT ORGANIZERS OVER A WIRELESS LOCAL AREA NETWORK (U.S. CLS. 21, 23, 26, 36 AND 38).

FIRST USE 4-28-2009; IN COMMERCE 4-28-2009.

---

3,941,733. RSIGNIA, INC., COLUMBIA, MD. SN 77-907,590. PUB. 6-15-2010, FILED 1-8-2010.

**Cyber Warrior**

THE MARK CONSISTS OF STANDARD CHARACTERS WITHOUT CLAIM TO ANY PARTICULAR FONT, STYLE, SIZE, OR COLOR.

NO CLAIM IS MADE TO THE EXCLUSIVE RIGHT TO USE "CYBER", APART FROM THE MARK AS SHOWN.

FOR COMPUTER PROGRAMS FOR NETWORK MANAGEMENT AND SECURITY, NETWORK PACKET CAPTURE, NETWORK MONITORING, NETWORK TRAFFIC CHARACTERIZATION AND NETWORK INTRUSION DETECTION AND TRACING THE ORIGIN OF NETWORK TRAFFIC GEOLOCATION INFORMATION, AND USING SINGLE OR MULTIPLE PROCESSORS; COMPUTER SOFTWARE FOR ADMINISTRATION OF COMPUTER NETWORKS; COMPUTER SOFTWARE FOR ENCRYPTION; COMPUTER SOFTWARE FOR USE IN THE ENCRYPTION AND DECRYPTION OF DIGITAL FILES, INCLUDING AUDIO, VIDEO, TEXT, BINARY, STILL IMAGES, GRAPHICS AND MULTIMEDIA FILES; COMPUTER SOFTWARE FOR USE IN THE SAFEGUARDING OF DIGITAL FILES, INCLUDING AUDIO, VIDEO, TEXT, BINARY, STILL IMAGES, GRAPHICS AND MULTIMEDIA FILES; COMPUTER SOFTWARE FOR NETWORK MANAGEMENT AND SECURITY, NETWORK PACKET CAPTURE, NETWORK MONITORING, NETWORK TRAFFIC CHARACTERIZATION AND NETWORK INTRUSION DETECTION AND TRACING THE ORIGIN OF NETWORK TRAFFIC GEOLOCATION INFORMATION, AND USING SINGLE OR MULTIPLE PROCESSORS (U.S. CLS. 21, 23, 26, 36 AND 38).

FIRST USE 1-7-2010; IN COMMERCE 5-25-2010.

**CLASS 9—(Continued).**

3,941,745. SYNOLOGY, INC., TAIPEI, TAIWAN. SN 77-910,217. PUB. 6-1-2010, FILED 1-12-2010.

**VISUALSTATION**

THE MARK CONSISTS OF STANDARD CHARACTERS WITHOUT CLAIM TO ANY PARTICULAR FONT, STYLE, SIZE, OR COLOR.

FOR COMPUTER HARDWARE; COMPUTER SOFTWARE FOR CONTROLLING AND MANAGING ACCESS SERVER APPLICATIONS; COMPUTER SOFTWARE FOR DISPLAYING, SERVING OR STREAMING AUDIO AND VIDEO; COMPUTER SOFTWARE FOR VIEWING DATA FROM CAMERAS OR RECORDED VIDEO (U.S. CLS. 21, 23, 26, 36 AND 38).

FIRST USE 11-1-2009; IN COMMERCE 11-1-2009.

---

3,941,775. THE KNOT, INC., NEW YORK, NY. SN 77-914,562. PUB. 6-8-2010, FILED 1-19-2010.

**WEDDING911 BY THE KNOT**

THE MARK CONSISTS OF STANDARD CHARACTERS WITHOUT CLAIM TO ANY PARTICULAR FONT, STYLE, SIZE, OR COLOR.

OWNER OF U.S. REG. NOS. 2,889,317, 3,365,658, AND OTHERS.

FOR APPLICATION SOFTWARE FOR MOBILE PHONES AND OTHER PORTABLE AND HAND-HELD DIGITAL ELECTRONIC DEVICES PROVIDING THE USER WITH INTERACTIVE ACCESS TO INFORMATION ABOUT WEDDINGS AND WEDDING-RELATED SERVICES (U.S. CLS. 21, 23, 26, 36 AND 38).

FIRST USE 7-31-2009; IN COMMERCE 7-31-2009.

---

3,941,776. NATIONAL DISTRIBUTION WAREHOUSE, INC., BROOKLYN, NY. SN 77-914,832. PUB. 6-1-2010, FILED 1-19-2010.

**TRUE POWER**

THE MARK CONSISTS OF STANDARD CHARACTERS WITHOUT CLAIM TO ANY PARTICULAR FONT, STYLE, SIZE, OR COLOR.

NO CLAIM IS MADE TO THE EXCLUSIVE RIGHT TO USE "POWER", APART FROM THE MARK AS SHOWN.

FOR BATTERIES AND BATTERY CHARGERS (U.S. CLS. 21, 23, 26, 36 AND 38).

FIRST USE 5-0-2010; IN COMMERCE 5-0-2010.

**CLASS 9—(Continued).**

3,941,777. TOURNAMENT ONE CORP, AKA T1 GAMING, T1, TOC, STAMFORD, CT. SN 77-915,366. PUB. 6-1-2010, FILED 1-19-2010.

**PENGUINS REVENGE**

THE MARK CONSISTS OF STANDARD CHARACTERS WITHOUT CLAIM TO ANY PARTICULAR FONT, STYLE, SIZE, OR COLOR.

FOR COMPUTER GAME SOFTWARE FOR GAMING MACHINES INCLUDING SLOT MACHINES OR VIDEO LOTTERY TERMINALS; COMPUTER SOFTWARE AND FIRMWARE FOR GAMES OF CHANCE ON ANY COMPUTERIZED PLATFORM, INCLUDING DEDICATED GAMING CONSOLES, VIDEO BASED SLOT MACHINES, REEL BASED SLOT MACHINES, AND VIDEO LOTTERY TERMINALS; DOWNLOADABLE ELECTRONIC GAMES VIA THE INTERNET AND WIRELESS DEVICES; ELECTRONIC GAME SOFTWARE FOR CELLULAR TELEPHONES; ELECTRONIC GAME SOFTWARE FOR HANDHELD ELECTRONIC DEVICES; ELECTRONIC GAME SOFTWARE FOR WIRELESS DEVICES (U.S. CLS. 21, 23, 26, 36 AND 38).

FIRST USE 1-19-2010; IN COMMERCE 11-30-2010.

---

3,941,778. SUMOPTI, PALO ALTO, CA. SN 77-915,628. PUB. 6-8-2010, FILED 1-20-2010.

**SUMOPTI**

THE MARK CONSISTS OF STANDARD CHARACTERS WITHOUT CLAIM TO ANY PARTICULAR FONT, STYLE, SIZE, OR COLOR.

FOR COMPUTER HARDWARE; COMPUTER SOFTWARE FOR DATA PROCESSING (U.S. CLS. 21, 23, 26, 36 AND 38).

FIRST USE 1-31-2011; IN COMMERCE 1-31-2011.

---

3,941,785. SHOEI CO., LTD., TOKYO, JAPAN. SN 77-916,234. PUB. 4-27-2010, FILED 1-20-2010.

**VFX-W**

THE MARK CONSISTS OF STANDARD CHARACTERS WITHOUT CLAIM TO ANY PARTICULAR FONT, STYLE, SIZE, OR COLOR.

FOR MOTORCYCLE HELMETS; MOTORBIKE HELMETS (U.S. CLS. 21, 23, 26, 36 AND 38).

FIRST USE 4-1-2009; IN COMMERCE 4-1-2009.



**CLASS 9—(Continued).**

3,941,790. WOOD, MARTIN J., POWAY, CA. SN 77-917,846.  
PUB. 6-8-2010, FILED 1-22-2010.

# GATOR

THE MARK CONSISTS OF STANDARD CHARACTERS WITHOUT CLAIM TO ANY PARTICULAR FONT, STYLE, SIZE, OR COLOR.

FOR ALL-PURPOSE CAMERA MOUNTS (U.S. CLS. 21, 23, 26, 36 AND 38).

FIRST USE 2-20-2010; IN COMMERCE 2-20-2010.

---

3,941,791. CRESTRON ELECTRONICS INC., ROCKLEIGH, NJ. SN 77-917,893. PUB. 6-1-2010, FILED 1-22-2010.

# FreeSpeech

THE MARK CONSISTS OF STANDARD CHARACTERS WITHOUT CLAIM TO ANY PARTICULAR FONT, STYLE, SIZE, OR COLOR.

FOR AUDIO DISTRIBUTION SYSTEM CONSISTING PRIMARILY OF MICROPHONES WITH PROXIMITY DETECTION, MICROPHONES USING BOTH INFRARED AND RADIO FREQUENCY COMMUNICATION, AND ASSOCIATED AUDIO DISTRIBUTION AND NETWORKING COMPONENTS, NAMELY, RECEIVERS, SPEAKERS, ROUTERS AND INTERFACES (U.S. CLS. 21, 23, 26, 36 AND 38).

FIRST USE 11-1-2009; IN COMMERCE 1-21-2011.

---

3,941,795. INTERJACENT TECHNOLOGY SYSTEMS, INC., CORRALITOS, CA. SN 77-918,574. PUB. 6-8-2010, FILED 1-22-2010.

# WHAT'S THAT

THE MARK CONSISTS OF STANDARD CHARACTERS WITHOUT CLAIM TO ANY PARTICULAR FONT, STYLE, SIZE, OR COLOR.

FOR DOWNLOADABLE COMPUTER SOFTWARE FOR USE ON MOBILE PHONES, SMART PHONES AND OTHER MOBILE DEVICES FOR INTEGRATING GEOLOCATION DATA AND INFORMATION ABOUT PLACES OF INTEREST (U.S. CLS. 21, 23, 26, 36 AND 38).

FIRST USE 1-18-2011; IN COMMERCE 1-18-2011.

**CLASS 9—(Continued).**

3,941,802. RELUME TECHNOLOGIES, INC., OXFORD, MI. SN 77-919,019. PUB. 6-8-2010, FILED 1-25-2010.

# Sentinel

THE MARK CONSISTS OF STANDARD CHARACTERS WITHOUT CLAIM TO ANY PARTICULAR FONT, STYLE, SIZE, OR COLOR.

FOR RADIO TRANSMITTERS, RECEIVERS, AND CONTROLLERS FOR MONITORING AND CONTROLLING PUBLIC LIGHTING (U.S. CLS. 21, 23, 26, 36 AND 38).

FIRST USE 3-10-2010; IN COMMERCE 3-10-2010.

---

3,941,816. CAPSUGEL BELGIUM BVBA, BORNEM, BELGIUM. SN 77-920,328. PUB. 6-8-2010, FILED 1-26-2010.

# XCELOLAB

THE MARK CONSISTS OF STANDARD CHARACTERS WITHOUT CLAIM TO ANY PARTICULAR FONT, STYLE, SIZE, OR COLOR.

OWNER OF U.S. REG. NOS. 2,954,067, 3,418,979, AND 3,459,407.

FOR METERING AND MEASURING AUTOMATED AND PROGRAMMABLE EQUIPMENT FOR MEASURING AND METERING DRUGS INTO CAPSULES AND OTHER SOLID DOSE FORM CONTAINERS (U.S. CLS. 21, 23, 26, 36 AND 38).

FIRST USE 11-4-2010; IN COMMERCE 11-4-2010.

---

3,941,823. CONCEPTUAL CALCULATIONS LLC, PETALUMA, CA. SN 77-921,196. PUB. 6-15-2010, FILED 1-27-2010.

# CONCEPTUA

THE MARK CONSISTS OF STANDARD CHARACTERS WITHOUT CLAIM TO ANY PARTICULAR FONT, STYLE, SIZE, OR COLOR.

FOR CHILDREN'S EDUCATIONAL SOFTWARE; EDUCATIONAL SOFTWARE FEATURING INSTRUCTION IN MATH FRACTIONS (U.S. CLS. 21, 23, 26, 36 AND 38).

FIRST USE 11-25-2010; IN COMMERCE 11-25-2010.

**CLASS 9—(Continued).**

3,941,845. BOYLE, BRENDAN, MONTE RIO, CA. SN 77-925,723. PUB. 6-15-2010, FILED 2-2-2010.

# My.Lie

THE MARK CONSISTS OF STANDARD CHARACTERS WITHOUT CLAIM TO ANY PARTICULAR FONT, STYLE, SIZE, OR COLOR.

FOR DIGITAL MEDIA, NAMELY, CDS, DVDS, AND DOWNLOADABLE AUDIO FILES FEATURING MUSIC (U.S. CLS. 21, 23, 26, 36 AND 38).

FIRST USE 3-1-2010; IN COMMERCE 3-1-2010.

3,941,855. REFLEX SYSTEMS LLC, ATLANTA, GA. SN 77-927,357. PUB. 5-11-2010, FILED 2-3-2010.

# vProfile

THE MARK CONSISTS OF STANDARD CHARACTERS WITHOUT CLAIM TO ANY PARTICULAR FONT, STYLE, SIZE, OR COLOR.

FOR COMPUTER SOFTWARE FOR FILE SYSTEM SECURITY; COMPUTER NETWORK, SYSTEM, APPLICATION, FILE, AND DATA SECURITY SOFTWARE; COMPUTER SOFTWARE FOR THE MANAGEMENT AND MONITORING OF COMPUTER NETWORKS, SYSTEMS, APPLICATIONS, FILES, AND DATA; COMPUTER SOFTWARE FOR THE DETECTION, ANALYSIS, REPORTING, AND RESTORATION OF CHANGES TO COMPUTER NETWORKS, SYSTEMS, APPLICATIONS, FILES, AND DATA (U.S. CLS. 21, 23, 26, 36 AND 38).

FIRST USE 12-1-2009; IN COMMERCE 3-24-2010.

**CLASS 9—(Continued).**

3,941,871. WMS GAMING INC., WAUKEGAN, IL. SN 77-929,494. PUB. 6-22-2010, FILED 2-5-2010.

## QUEEN OF THE WILD

THE MARK CONSISTS OF STANDARD CHARACTERS WITHOUT CLAIM TO ANY PARTICULAR FONT, STYLE, SIZE, OR COLOR.

FOR COMPONENTS FOR GAMING MACHINES THAT GENERATE OR DISPLAY WAGER OUTCOMES, NAMELY, CONTROLLERS, DISPLAYS, BUTTON PANELS, BOLSTERS, ELECTRICAL WIRING, AND COMPUTER HARDWARE AND SOFTWARE ASSOCIATED THEREWITH; GAMING MACHINES, NAMELY, DEVICES WHICH ACCEPT A WAGER; GAMING SOFTWARE THAT GENERATES OR DISPLAYS WAGER OUTCOMES OF GAMING MACHINES (U.S. CLS. 21, 23, 26, 36 AND 38).

FIRST USE 11-16-2010; IN COMMERCE 11-16-2010.

3,941,876. ESQUIRE INNOVATIONS, INC., TEMECULA, CA. SN 77-930,698. PUB. 6-29-2010, FILED 2-8-2010.



The logo for iCreateDA features the text "iCreateDA" in a serif font. To the right of the text is a graphic consisting of three overlapping rectangular shapes, each with a curved arrow pointing upwards and to the right, suggesting a process or flow.

OWNER OF U.S. REG. NOS. 2,383,001 AND 2,422,750.

THE MARK CONSISTS OF THE WORDS "ICREATEDA" JUXTAPOSED TO CASCADING FOLDERS ENCOMPASSED BY ARROWS AT THE TOP AND BOTTOM.

FOR COMPUTER APPLICATION SOFTWARE FOR DOCUMENT ASSEMBLY (U.S. CLS. 21, 23, 26, 36 AND 38).

FIRST USE 8-0-2006; IN COMMERCE 8-0-2006.

3,941,888. TWENTIETH CENTURY FOX FILM CORPORATION, LOS ANGELES, CA. SN 77-932,104. PUB. 6-15-2010, FILED 2-9-2010.

## PERCY JACKSON AND THE OLYMPIANS

THE MARK CONSISTS OF STANDARD CHARACTERS WITHOUT CLAIM TO ANY PARTICULAR FONT, STYLE, SIZE, OR COLOR.

**CLASS 9—(Continued).**

THE NAME "PERCY JACKSON" DOES NOT IDENTIFY A PARTICULAR LIVING INDIVIDUAL.

FOR PRE-RECORDED DVDS FEATURING ADVENTURE, DRAMA AND FANTASY; PRE-RECORDED CDS FEATURING ADVENTURE, DRAMA AND FANTASY AND MUSICAL PERFORMANCES; DOWNLOADABLE AUDIO RECORDINGS FEATURING ADVENTURE, DRAMA AND FANTASY; DOWNLOADABLE GRAPHICS, WALLPAPER, GAMES AND MUSIC VIA A GLOBAL COMPUTER NETWORK AND WIRELESS DEVICES; COMPUTER GAME AND VIDEO GAME SOFTWARE; DECORATIVE MAGNETS (U.S. CLS. 21, 23, 26, 36 AND 38).

FIRST USE 7-15-2009; IN COMMERCE 7-15-2009.

**CLASS 9—(Continued).**

3,941,897. TOURNAMENT ONE CORP, AKA T1 GAMING, T1, TOC, STAMFORD, CT. SN 77-934,391. PUB. 6-1-2010, FILED 2-12-2010.

**HEDGE FUND**

THE MARK CONSISTS OF STANDARD CHARACTERS WITHOUT CLAIM TO ANY PARTICULAR FONT, STYLE, SIZE, OR COLOR.

FOR COMPUTER GAME SOFTWARE DOWNLOADABLE FROM A GLOBAL COMPUTER NETWORK; COMPUTER GAME SOFTWARE FOR GAMING MACHINES INCLUDING SLOT MACHINES OR VIDEO LOTTERY TERMINALS; COMPUTER SOFTWARE AND FIRMWARE FOR GAMES OF CHANCE ON ANY COMPUTERIZED PLATFORM, INCLUDING DEDICATED GAMING CONSOLES, VIDEO BASED SLOT MACHINES, REEL BASED SLOT MACHINES, AND VIDEO LOTTERY TERMINALS; DOWNLOADABLE COMPUTER GAME PROGRAMS; DOWNLOADABLE COMPUTER NETWORK SOFTWARE VIA A GLOBAL COMPUTER NETWORK AND WIRELESS DEVICES; DOWNLOADABLE ELECTRONIC GAMES VIA THE INTERNET AND WIRELESS DEVICES; ELECTRONIC GAME SOFTWARE FOR CELLULAR TELEPHONES; ELECTRONIC GAME SOFTWARE FOR HANDHELD ELECTRONIC DEVICES; ELECTRONIC GAME SOFTWARE FOR WIRELESS DEVICES (U.S. CLS. 21, 23, 26, 36 AND 38).

FIRST USE 2-12-2010; IN COMMERCE 12-31-2010.

3,941,896. BETHESDA SOFTWARES LLC, ROCKVILLE, MD. SN 77-934,276. PUB. 7-13-2010, FILED 2-12-2010.



3,941,902. WMS GAMING INC., WAUKEGAN, IL. SN 77-935,962. PUB. 6-22-2010, FILED 2-15-2010.

**TOP STAR**

THE MARK CONSISTS OF STANDARD CHARACTERS WITHOUT CLAIM TO ANY PARTICULAR FONT, STYLE, SIZE, OR COLOR.

FOR COMPONENTS FOR GAMING MACHINES THAT GENERATE OR DISPLAY WAGER OUTCOMES, NAMELY, CONTROLLERS, DISPLAYS, BUTTON PANELS, BOLSTERS, ELECTRICAL WIRING, AND COMPUTER HARDWARE AND SOFTWARE ASSOCIATED THEREWITH; GAMING MACHINES, NAMELY, DEVICES WHICH ACCEPT A WAGER; GAMING SOFTWARE THAT GENERATES OR DISPLAYS WAGER OUTCOMES OF GAMING MACHINES (U.S. CLS. 21, 23, 26, 36 AND 38).

FIRST USE 11-16-2010; IN COMMERCE 11-16-2010.

OWNER OF U.S. REG. NOS. 2,181,084 AND 3,583,756.  
THE MARK CONSISTS OF THE WORD "FALLOUT" OVER THE WORDS "NEW VEGAS", ALL IN A PARALLELOGRAM WITH A LIGHTNING BOLT RUNNING DIAGONALLY THROUGH THE "O" IN "FALLOUT".

FOR COMPUTER GAME SOFTWARE FOR USE WITH COMPUTERS AND VIDEO GAME CONSOLES; DOWNLOADABLE COMPUTER GAME SOFTWARE OFFERED VIA THE INTERNET AND WIRELESS DEVICES (U.S. CLS. 21, 23, 26, 36 AND 38).

FIRST USE 10-19-2010; IN COMMERCE 10-19-2010.

**CLASS 9—(Continued).**

3,941,906. WMS GAMING INC., WAUKEGAN, IL. SN 77-937,432. PUB. 6-22-2010, FILED 2-17-2010.

**HEART AND SOUL**

THE MARK CONSISTS OF STANDARD CHARACTERS WITHOUT CLAIM TO ANY PARTICULAR FONT, STYLE, SIZE, OR COLOR.

FOR COMPONENTS FOR GAMING MACHINES THAT GENERATE OR DISPLAY WAGER OUTCOMES, NAMELY, CONTROLLERS, DISPLAYS, BUTTON PANELS, BOLSTERS, ELECTRICAL WIRING, AND COMPUTER HARDWARE AND SOFTWARE ASSOCIATED THEREWITH; GAMING MACHINES, NAMELY, DEVICES WHICH ACCEPT A WAGER; GAMING SOFTWARE THAT GENERATES OR DISPLAYS WAGER OUTCOMES OF GAMING MACHINES (U.S. CLS. 21, 23, 26, 36 AND 38).

FIRST USE 11-16-2010; IN COMMERCE 11-16-2010.

**CLASS 9—(Continued).**

3,941,909. WMS GAMING INC., WAUKEGAN, IL. SN 77-937,985. PUB. 6-22-2010, FILED 2-17-2010.

**RUBY STAR**

THE MARK CONSISTS OF STANDARD CHARACTERS WITHOUT CLAIM TO ANY PARTICULAR FONT, STYLE, SIZE, OR COLOR.

FOR COMPONENTS FOR GAMING MACHINES THAT GENERATE OR DISPLAY WAGER OUTCOMES, NAMELY, CONTROLLERS, DISPLAYS, BUTTON PANELS, BOLSTERS, ELECTRICAL WIRING, AND COMPUTER HARDWARE AND SOFTWARE ASSOCIATED THEREWITH; GAMING MACHINES, NAMELY, DEVICES WHICH ACCEPT A WAGER; GAMING SOFTWARE THAT GENERATES OR DISPLAYS WAGER OUTCOMES OF GAMING MACHINES (U.S. CLS. 21, 23, 26, 36 AND 38).

FIRST USE 11-16-2010; IN COMMERCE 11-16-2010.

3,941,928. DYNAWAVE INCORPORATED, HAVERHILL, MA. SN 77-944,593. PUB. 6-1-2010, FILED 2-25-2010.

**DYNACORE**

THE MARK CONSISTS OF STANDARD CHARACTERS WITHOUT CLAIM TO ANY PARTICULAR FONT, STYLE, SIZE, OR COLOR.

FOR MICROWAVE COMPONENTS, NAMELY, COAXIAL CABLE FOR USE IN RADIO FREQUENCY TRANSMISSION (U.S. CLS. 21, 23, 26, 36 AND 38).

FIRST USE 4-1-2010; IN COMMERCE 4-1-2010.

3,941,908. WMS GAMING INC., WAUKEGAN, IL. SN 77-937,979. PUB. 6-22-2010, FILED 2-17-2010.

**JEWELS OF AUSTRALIA**

THE MARK CONSISTS OF STANDARD CHARACTERS WITHOUT CLAIM TO ANY PARTICULAR FONT, STYLE, SIZE, OR COLOR.

FOR COMPONENTS FOR GAMING MACHINES THAT GENERATE OR DISPLAY WAGER OUTCOMES, NAMELY, CONTROLLERS, DISPLAYS, BUTTON PANELS, BOLSTERS, ELECTRICAL WIRING, AND COMPUTER HARDWARE AND SOFTWARE ASSOCIATED THEREWITH; GAMING MACHINES, NAMELY, DEVICES WHICH ACCEPT A WAGER; GAMING SOFTWARE THAT GENERATES OR DISPLAYS WAGER OUTCOMES OF GAMING MACHINES (U.S. CLS. 21, 23, 26, 36 AND 38).

FIRST USE 11-16-2010; IN COMMERCE 11-16-2010.

3,941,929. IMPACT TECHNOLOGIES, LLC, ROCHESTER, NY. SN 77-944,768. PUB. 11-2-2010, FILED 2-25-2010.

**SENTYRE**

THE MARK CONSISTS OF STANDARD CHARACTERS WITHOUT CLAIM TO ANY PARTICULAR FONT, STYLE, SIZE, OR COLOR.

FOR ELECTRONIC DEVICES FOR MONITORING VIBRATION, NAMELY, DEVICES THAT CAPTURE, PROCESS AND COMMUNICATE DATA (U.S. CLS. 21, 23, 26, 36 AND 38).

FIRST USE 12-7-2009; IN COMMERCE 4-13-2010.

**CLASS 9—(Continued).**

3,941,933. CREATIVE BRAND WORKS, DEXTER, MI. SN 77-945,161. PUB. 7-20-2010, FILED 2-25-2010.

# HOODY

THE MARK CONSISTS OF STANDARD CHARACTERS WITHOUT CLAIM TO ANY PARTICULAR FONT, STYLE, SIZE, OR COLOR.

FOR A VIEW LIMITING APPARATUS CONSISTING OF A VISOR TYPE DEVICE AND VIEW BLOCKING PLASTIC FLAPS ON THE SIDES USED IN FLIGHT TRAINING ALLOWING THE PILOT TO PRACTICE PRECISE CONTROL OF THE AIRCRAFT WITHOUT VISUAL REFERENCE TO THE NATURAL HORIZON, AS IN A SITUATION OF FLIGHT THROUGH CLOUDS OR IN AREAS OF REDUCED VISIBILITY (U.S. CLS. 21, 23, 26, 36 AND 38).

FIRST USE 1-31-2011; IN COMMERCE 2-14-2011.

3,941,959. AINSWORTH GAME TECHNOLOGY LIMITED, NEWINGTON, AUSTRALIA. SN 77-956,133. PUB. 8-17-2010, FILED 3-11-2010.

# China Tiger

THE MARK CONSISTS OF STANDARD CHARACTERS WITHOUT CLAIM TO ANY PARTICULAR FONT, STYLE, SIZE, OR COLOR.

NO CLAIM IS MADE TO THE EXCLUSIVE RIGHT TO USE "CHINA", APART FROM THE MARK AS SHOWN.

FOR COMPUTER SOFTWARE AND FIRMWARE FOR GAMES OF CHANCE ON ANY COMPUTERIZED PLATFORM, INCLUDING DEDICATED GAMING CONSOLES, VIDEO BASED SLOT MACHINES, REEL BASED SLOT MACHINES, AND VIDEO LOTTERY TERMINALS (U.S. CLS. 21, 23, 26, 36 AND 38).

FIRST USE 10-15-2010; IN COMMERCE 10-15-2010.

3,941,960. MANUFACTURING RESOURCES INTERNATIONAL, INC., ALPHARETTA, GA. SN 77-956,652. PUB. 6-1-2010, FILED 3-11-2010.

# DYNAMICVU

THE MARK CONSISTS OF STANDARD CHARACTERS WITHOUT CLAIM TO ANY PARTICULAR FONT, STYLE, SIZE, OR COLOR.

FOR LIQUID CRYSTAL DISPLAY (LCD) MONITORS (U.S. CLS. 21, 23, 26, 36 AND 38).

FIRST USE 7-22-2010; IN COMMERCE 7-22-2010.

**CLASS 9—(Continued).**

3,941,981. PERFORMANCE FABRICS, INC., DBA HEXARMOR, GRAND RAPIDS, MI. SN 77-961,206. PUB. 8-10-2010, FILED 3-17-2010.

# SHARPSMASTER II

THE MARK CONSISTS OF STANDARD CHARACTERS WITHOUT CLAIM TO ANY PARTICULAR FONT, STYLE, SIZE, OR COLOR.

FOR PROTECTIVE GLOVES FOR INDUSTRIAL USE; PROTECTIVE WORK GLOVES (U.S. CLS. 21, 23, 26, 36 AND 38).

FIRST USE 3-3-2009; IN COMMERCE 3-3-2009.

3,941,996. DB RESEARCH LLP, HARLINGEN, TX. SN 77-967,303. PUB. 8-17-2010, FILED 3-24-2010.

# OKUR

THE MARK CONSISTS OF STANDARD CHARACTERS WITHOUT CLAIM TO ANY PARTICULAR FONT, STYLE, SIZE, OR COLOR.

FOR HOME AND MOBILE AUDIO EQUIPMENT, NAMELY, AUDIO SPEAKERS, SUBWOOFERS, CAPACITORS, STEREO AMPLIFIERS, REMOTE CONTROLS FOR USE WITH AUDIO EQUIPMENT; ELECTRICAL WIRES; AND ELECTRONIC WIRE HARNESSES, AMPLIFIERS AND INSTALLATION ACCESSORIES, NAMELY, CABLES, LOOMS, ADAPTORS, FUSES, FUSE HOLDERS, FUSE BLOCKS, GROUND BLOCKS, CIRCUIT BREAKERS, BATTERY TERMINALS, BARREL CONNECTORS, RCA CONNECTORS, LEVEL INPUTS, NOISE REJECTION FILTERS, RING TERMINALS, POWER WIRES, GROUND WIRES, REMOTE WIRES, SPEAKER WIRES, AND WIRE TIES (U.S. CLS. 21, 23, 26, 36 AND 38).

FIRST USE 1-2-2010; IN COMMERCE 1-2-2010.

3,942,013. ZOO GAMES, INC., NEW YORK, NY. SN 77-981,124. PUB. 3-10-2009, FILED 4-14-2008.

# ZOO

THE MARK CONSISTS OF STANDARD CHARACTERS WITHOUT CLAIM TO ANY PARTICULAR FONT, STYLE, SIZE, OR COLOR.

FOR COMPUTER GAME PROGRAMS AND SOFTWARE; INTERACTIVE VIDEO GAME PROGRAMS AND SOFTWARE (U.S. CLS. 21, 23, 26, 36 AND 38).

FIRST USE 10-1-2008; IN COMMERCE 10-1-2008.

**CLASS 9—(Continued).**

3,942,034. QUALCOMM INCORPORATED, SAN DIEGO, CA. SN 77-981,333. PUB. 7-13-2010, FILED 12-11-2009.



THE MARK CONSISTS OF A STYLIZED LETTER "S" INSIDE A CIRCLE WITH A SLASH THROUGH BOTH THE CIRCLE AND THE LETTER "S". THE LITERAL ELEMENT "SWAGG" IS LOCATED BELOW THE CIRCLE "S" AND HAS A CURVED LINE UNDERNEATH THE "W" AND "A" LETTERS OF THE LITERAL ELEMENT.

FOR COMPUTER E-COMMERCE AND MOBILE COMMERCE SOFTWARE TO ALLOW USERS TO PERFORM ELECTRONIC BUSINESS TRANSACTIONS VIA A GLOBAL COMPUTER NETWORK; COMPUTER SOFTWARE AND DOWNLOADABLE COMPUTER SOFTWARE FOR USE WITH MOBILE PHONES AND MOBILE DIGITAL DEVICES FOR PROVIDING FINANCIAL SERVICES, DEBIT CARD SERVICES, GIFT CARD SERVICES, LOYALTY ACCOUNT MANAGEMENT, REDEMPTION SERVICES, MAPS AND DIRECTION SERVICES, AND LOCATION BASED SHOPPING INFORMATION AND RECOMMENDATION SERVICES USING GLOBAL POSITIONING SERVICES (GPS) TECHNOLOGY AND OTHER LOCATING-SENSING TECHNOLOGY (U.S. CLS. 21, 23, 26, 36 AND 38).

FIRST USE 11-23-2010; IN COMMERCE 11-23-2010.

3,942,035. QUALCOMM INCORPORATED, SAN DIEGO, CA. SN 77-981,341. PUB. 6-15-2010, FILED 12-11-2009.

# SWAGG

THE MARK CONSISTS OF STANDARD CHARACTERS WITHOUT CLAIM TO ANY PARTICULAR FONT, STYLE, SIZE, OR COLOR.

FOR COMPUTER E-COMMERCE AND MOBILE COMMERCE SOFTWARE TO ALLOW USERS TO PERFORM ELECTRONIC BUSINESS TRANSACTIONS VIA A GLOBAL COMPUTER NETWORK; COMPUTER SOFTWARE AND DOWNLOADABLE COMPUTER SOFTWARE FOR USE WITH MOBILE PHONES AND MOBILE DIGITAL DEVICES FOR PROVIDING FINANCIAL SERVICES, DEBIT CARD SERVICES, GIFT CARD SERVICES, LOYALTY ACCOUNT MANAGEMENT, REDEMPTION SERVICES, MAPS AND DIRECTION SERVICES, AND LOCATION BASED SHOPPING INFORMATION AND RECOMMENDATION SERVICES USING GLOBAL POSITIONING SERVICES (GPS) TECHNOLOGY AND OTHER LOCATING-SENSING TECHNOLOGY (U.S. CLS. 21, 23, 26, 36 AND 38).

FIRST USE 11-23-2010; IN COMMERCE 11-23-2010.

**CLASS 9—(Continued).**

3,942,037. DAVID C COOK, COLORADO SPRINGS, CO. SN 77-981,366. PUB. 1-5-2010, FILED 8-25-2008.



THE MARK CONSISTS OF THE WORDS "CRAZY LOVE" ACCOMPANIED BY OPPOSITE DIRECTIONAL ARROWS. FOR PRE-RECORDED CDS AND DVDS FEATURING CHRISTIAN FAITH (U.S. CLS. 21, 23, 26, 36 AND 38).

FIRST USE 12-1-2008; IN COMMERCE 12-1-2008.

3,942,043. RAYTHEON COMPANY, WALTHAM, MA. SN 77-981,424. PUB. 1-6-2009, FILED 6-4-2008.

**ELEMENTAL ZINC SULFIDE**

THE MARK CONSISTS OF STANDARD CHARACTERS WITHOUT CLAIM TO ANY PARTICULAR FONT, STYLE, SIZE, OR COLOR.

NO CLAIM IS MADE TO THE EXCLUSIVE RIGHT TO USE "ZINC SULFIDE", APART FROM THE MARK AS SHOWN.

FOR TRANSPARENT MATERIAL IN THE NATURE OF LENSES AND OPTICS ASSEMBLIES FOR USE IN INFRARED DETECTORS FOR USE IN MILITARY, LAW ENFORCEMENT, CIVIL, SCIENTIFIC AND INDUSTRIAL APPLICATIONS; TRANSPARENT MATERIAL IN THE NATURE OF LENSES AND OPTICS ASSEMBLIES FOR USE IN ELECTRONIC COMPONENTS IN THE NATURE OF INFRARED DETECTORS FOR USE IN FURTHER MANUFACTURE; TRANSPARENT MATERIAL IN THE NATURE OF LENSES AND OPTICS ASSEMBLIES FOR USE IN ELECTRONIC DETECTORS FOR OBSERVING AND MEASURING THE INFRARED SPECTRUM, NAMELY, INFRARED DETECTORS (U.S. CLS. 21, 23, 26, 36 AND 38).

FIRST USE 10-9-2009; IN COMMERCE 10-9-2009.

**CLASS 9—(Continued).**

3,942,073. ZEEMOTE LLC, SAN FRANCISCO, CA. SN 78-971,721. PUB. 4-8-2008, FILED 9-11-2006.

# ZEEMOTE

THE MARK CONSISTS OF STANDARD CHARACTERS WITHOUT CLAIM TO ANY PARTICULAR FONT, STYLE, SIZE, OR COLOR.

FOR SOFTWARE AND HARDWARE FOR CONTROLLING HOME ENTERTAINMENT APPLIANCES AND OTHER ELECTRONIC DEVICES, NAMELY, PERSONAL COMPUTERS; ELECTRONIC AND WIRELESS HANDHELD DEVICES FOR CONTROLLING MOBILE GAMING DEVICES, NAMELY, PLAYER-OPERATED ELECTRONIC CONTROLLERS FOR PLAYING ELECTRONIC COMPUTER AND VIDEO GAMES, NAMELY, SKILL GAMES, TRIVIA GAMES, PUZZLE GAMES, CARD GAMES, ACTION GAMES, GAMES OF CHANCE AND MULTI-PLAYER GAMES (U.S. CLS. 21, 23, 26, 36 AND 38).

FIRST USE 6-11-2010; IN COMMERCE 6-11-2010.

---

3,942,081. PMC GAGE, INC., WILLOUGHBY, OH. SN 85-002,556. PUB. 8-24-2010, FILED 3-30-2010.

# GF GAGE

THE MARK CONSISTS OF STANDARD CHARACTERS WITHOUT CLAIM TO ANY PARTICULAR FONT, STYLE, SIZE, OR COLOR.

NO CLAIM IS MADE TO THE EXCLUSIVE RIGHT TO USE "GAGE", APART FROM THE MARK AS SHOWN.

FOR CONFORMITY CHECKING AND MEASURING GAGES FOR USE BY THE MANUFACTURING INDUSTRY TO VERIFY ACCURACY OF INTER-FITTING FABRICATED COMPONENTS; APPARATUS AND INSTRUMENTS FOR CHECKING AND MEASURING SHAPES, PROFILES, DIMENSIONS, TOLERANCES, PITCHES AND ALIGNMENTS IN MACHINED, CAST, FORGED AND FABRICATED COMPONENTS (U.S. CLS. 21, 23, 26, 36 AND 38).

FIRST USE 9-30-2010; IN COMMERCE 9-30-2010.

**CLASS 9—(Continued).**

3,942,091. KABUSHIKI KAISHA TAITO, TOKYO 151-0053, JAPAN. SN 85-007,801. PUB. 8-31-2010, FILED 4-6-2010.

# SPACE INVADERS

THE MARK CONSISTS OF STANDARD CHARACTERS WITHOUT CLAIM TO ANY PARTICULAR FONT, STYLE, SIZE, OR COLOR.

OWNER OF U.S. REG. NO. 1,272,444.

FOR DOWNLOADABLE SOFTWARE FOR USE AS COMPUTER GAME PROGRAMS, PRE-RECORDED MAGNETIC DATA CARRIERS FEATURING GAMES; PRE-RECORDED DIGITAL VIDEO DISCS FEATURING GAMES; DOWNLOADABLE SOFTWARE FOR USE AS GAME PROGRAMS ON MOBILE TELEPHONES AND OTHER TELEPHONE APPARATUS; COMPUTER PROGRAMS FOR PLAYING GAMES RECORDED ON MOBILE TELEPHONES AND OTHER TELEPHONE APPARATUS; AND ELECTRONIC GAME PROGRAMS; COMPUTER GAME PROGRAMS FOR PERSONAL COMPUTERS; DOWNLOADABLE SOFTWARE FOR USE AS COMPUTER GAME PROGRAMS FOR PERSONAL COMPUTERS; COMPUTER GAME PROGRAMS FOR PERSONAL COMPUTERS PRE-RECORDED ON CARTRIDGES, DISCS, TAPES, CARDS AND ELECTRONIC CIRCUITS; VIDEO AND COMPUTER GAME PROGRAMS FOR HOME USE GAME MACHINES; VIDEO GAME PROGRAMS FOR USE ON HOME USE GAME MACHINES PRE-RECORDED ON CARTRIDGES, DISCS, TAPES, CARDS AND ELECTRONIC CIRCUITS; VIDEO AND COMPUTER GAME PROGRAMS FOR HANDHELD GAME MACHINES WITH A DISPLAY SCREEN; DOWNLOADABLE SOFTWARE FOR USE AS GAME PROGRAMS ON HANDHELD GAME MACHINES WITH A DISPLAY SCREEN; COMPUTER GAME PROGRAMS FOR HANDHELD GAME MACHINES WITH A DISPLAY SCREEN PRE-RECORDED ON CARTRIDGES, DISCS, TAPES, CARDS AND ELECTRONIC CIRCUITS; PRE-RECORDED MAGNETIC DATA CARRIERS FEATURING GAMES; PRE-RECORDED DIGITAL VIDEO DISCS FEATURING GAMES (U.S. CLS. 21, 23, 26, 36 AND 38).

FIRST USE 1-0-2001; IN COMMERCE 8-18-2009.

---

3,942,107. NEXTLABS, INC., SAN MATEO, CA. SN 85-014,659. PUB. 9-14-2010, FILED 4-15-2010.

# 360 DEGREE ENFORCEMENT

THE MARK CONSISTS OF STANDARD CHARACTERS WITHOUT CLAIM TO ANY PARTICULAR FONT, STYLE, SIZE, OR COLOR.

FOR COMPUTER PROGRAMS FOR USE IN INFORMATION RISK MANAGEMENT AND COMPLIANCE TECHNOLOGY APPLICATIONS, NAMELY, COMPUTER PROGRAMS FOR EDUCATING END USERS, PROTECTING CRITICAL DATA, AND AUTOMATING DATA PROTECTION PROCEDURES (U.S. CLS. 21, 23, 26, 36 AND 38).

FIRST USE 7-31-2010; IN COMMERCE 7-31-2010.

**CLASS 9—(Continued).**

3,942,112. CHU, DARRYL, FOREST HILLS, NY. SN 85-016,536. PUB. 9-21-2010, FILED 4-17-2010.



THE MARK CONSISTS OF THE STYLIZED WORDING "ICARPUS" IN WHICH THE LETTERS "I" AND "C" ARE JOINED TOGETHER TO FORM AN ABSTRACT SHAPE. FOR STANDS FOR HANDHELD DIGITAL ELECTRONIC DEVICES (U.S. CLS. 21, 23, 26, 36 AND 38). FIRST USE 8-1-2010; IN COMMERCE 8-1-2010.

3,942,117. RIAENJOLIE, INC., PLAINSBORO, NJ. SN 85-020,307. PUB. 10-19-2010, FILED 4-22-2010.

## IBUYIHELP

THE MARK CONSISTS OF STANDARD CHARACTERS WITHOUT CLAIM TO ANY PARTICULAR FONT, STYLE, SIZE, OR COLOR. FOR COMPUTER SOFTWARE FOR WEBSITE DEVELOPMENT AND FOR CREATING AND DEVELOPING INTERNET APPLICATIONS (U.S. CLS. 21, 23, 26, 36 AND 38). FIRST USE 9-1-2010; IN COMMERCE 9-1-2010.

3,942,118. CAPRI OPTICS, BROOKLYN, NY. SN 85-020,924. PUB. 9-21-2010, FILED 4-22-2010.

## Protech

THE MARK CONSISTS OF STANDARD CHARACTERS WITHOUT CLAIM TO ANY PARTICULAR FONT, STYLE, SIZE, OR COLOR. FOR SPORTS TRAINING EYEGLASSES (U.S. CLS. 21, 23, 26, 36 AND 38). FIRST USE 1-1-2011; IN COMMERCE 1-1-2011.

**CLASS 9—(Continued).**

3,942,125. ZOOM EYEWORKS, INC., BERKELEY, CA. SN 85-023,441. PUB. 11-9-2010, FILED 4-26-2010.

ZOOM RECOMMENDED READERS

THE MARK CONSISTS OF STANDARD CHARACTERS WITHOUT CLAIM TO ANY PARTICULAR FONT, STYLE, SIZE, OR COLOR.

OWNER OF U.S. REG. NOS. 3,072,132, 3,305,598, AND OTHERS.

NO CLAIM IS MADE TO THE EXCLUSIVE RIGHT TO USE "READERS", APART FROM THE MARK AS SHOWN. FOR EYEWEAR (U.S. CLS. 21, 23, 26, 36 AND 38). FIRST USE 3-0-2010; IN COMMERCE 3-0-2010.

3,942,141. FOURSIGHT GAME SYSTEMS, LLC, STAMFORD, CT. SN 85-028,889. PUB. 10-5-2010, FILED 5-3-2010.

## FOURSIGHT

THE MARK CONSISTS OF STANDARD CHARACTERS WITHOUT CLAIM TO ANY PARTICULAR FONT, STYLE, SIZE, OR COLOR.

FOR ELECTRONIC GAME SOFTWARE PLAYED ON COMPUTERS AND MOBILE TELEPHONES (U.S. CLS. 21, 23, 26, 36 AND 38).

FIRST USE 1-30-2011; IN COMMERCE 1-30-2011.

3,942,142. CLEAR CHANNEL OUTDOOR, INC., SAN ANTONIO, TX. SN 85-029,367. PUB. 10-5-2010, FILED 5-4-2010.

## FLYSMART

THE MARK CONSISTS OF STANDARD CHARACTERS WITHOUT CLAIM TO ANY PARTICULAR FONT, STYLE, SIZE, OR COLOR.

FOR DOWNLOADABLE SOFTWARE IN THE NATURE OF A MOBILE APPLICATION FOR USE IN DIRECTING LOCAL ADVERTISING USING GEO-LOCATION TECHNOLOGY (U.S. CLS. 21, 23, 26, 36 AND 38).

FIRST USE 5-16-2010; IN COMMERCE 5-16-2010.



**CLASS 9—(Continued).**

3,942,145. CAPITUS PTE LTD, SINGAPORE, SINGAPORE.  
SN 85-031,362. PUB. 10-5-2010, FILED 5-6-2010.



THE MARK CONSISTS OF THREE CROSSES JOINED AS A VARIATION OF A HERRINGBONE STITCH.  
FOR CASES FOR SPECTACLES AND SUNGLASSES;  
SPECTACLES AND SUNGLASSES (U.S. CLS. 21, 23, 26, 36 AND 38).

FIRST USE 1-3-2010; IN COMMERCE 10-7-2010.

3,942,158. KABUSHIKI KAISHA TAITO, TOKYO 151-0053,  
JAPAN. SN 85-039,479. PUB. 8-31-2010, FILED 5-15-2010.

**MIKADO DEFENDERS**

THE MARK CONSISTS OF STANDARD CHARACTERS WITHOUT CLAIM TO ANY PARTICULAR FONT, STYLE, SIZE, OR COLOR.

FOR COMPUTER GAME PROGRAMS FOR MOBILE PHONES; DOWNLOADABLE SOFTWARE FOR USE AS GAME PROGRAMS ON MOBILE TELEPHONES AND OTHER TELEPHONE APPARATUS; COMPUTER GAME PROGRAMS FOR PERSONAL DIGITAL ASSISTANTS; DOWNLOADABLE GAME PROGRAMS FOR PERSONAL DIGITAL ASSISTANTS; COMPUTER GAME PROGRAMS FOR PERSONAL COMPUTERS; DOWNLOADABLE SOFTWARE FOR USE AS COMPUTER GAME PROGRAMS FOR PERSONAL COMPUTERS; AND COMPUTER GAME PROGRAMS FOR PERSONAL COMPUTERS PRE-RECORDED ON CARTRIDGES, DISCS, TAPES, CARDS AND ELECTRONIC CIRCUITS (U.S. CLS. 21, 23, 26, 36 AND 38).

FIRST USE 4-19-2010; IN COMMERCE 4-19-2010.

**CLASS 9—(Continued).**

3,942,159. TIMELINE PRODUCTIONS LLC, DBA READY-STEADY, LINCOLN, NE. SN 85-039,888. PUB. 10-19-2010, FILED 5-17-2010.

Put it in your pocket.  
Shoot like a pro.

THE MARK CONSISTS OF STANDARD CHARACTERS WITHOUT CLAIM TO ANY PARTICULAR FONT, STYLE, SIZE, OR COLOR.

FOR CAMERA STABILITY ACCESSORY, NAMELY, A SUPPORT ARM, VEST AND SLED FOR FILM AND VIDEO CAMERAS TO ABSORB SHAKING MOVES WHILE SHOOTING (U.S. CLS. 21, 23, 26, 36 AND 38).

FIRST USE 8-15-2010; IN COMMERCE 8-15-2010.

3,942,179. WHITE SHOE MEDIA, INC., NEW YORK, NY. SN 85-045,837. PUB. 10-26-2010, FILED 5-23-2010.

**White Shoe Media**

THE MARK CONSISTS OF STANDARD CHARACTERS WITHOUT CLAIM TO ANY PARTICULAR FONT, STYLE, SIZE, OR COLOR.

NO CLAIM IS MADE TO THE EXCLUSIVE RIGHT TO USE "MEDIA", APART FROM THE MARK AS SHOWN.

FOR DOWNLOADABLE COMPUTER GAME PROGRAMS (U.S. CLS. 21, 23, 26, 36 AND 38).

FIRST USE 7-29-2010; IN COMMERCE 7-29-2010.

3,942,180. WHITE SHOE MEDIA, INC., NEW YORK, NY. SN 85-045,839. PUB. 10-26-2010, FILED 5-23-2010.

**SUBRATS**

THE MARK CONSISTS OF STANDARD CHARACTERS WITHOUT CLAIM TO ANY PARTICULAR FONT, STYLE, SIZE, OR COLOR.

FOR DOWNLOADABLE COMPUTER GAME PROGRAMS (U.S. CLS. 21, 23, 26, 36 AND 38).

FIRST USE 7-29-2010; IN COMMERCE 7-29-2010.

**CLASS 9—(Continued).**

3,942,182. PRICEWATERHOUSECOOPERS LLP, NEW YORK, NY. SN 85-046,466. PUB. 8-24-2010, FILED 5-24-2010.

**BOARDROOMDIRECT**

THE MARK CONSISTS OF STANDARD CHARACTERS WITHOUT CLAIM TO ANY PARTICULAR FONT, STYLE, SIZE, OR COLOR.

FOR DOWNLOADABLE ELECTRONIC NEWSLETTER IN THE AREAS OF ACCOUNTING, TAX AND BUSINESS ADVISORY ISSUES (U.S. CLS. 21, 23, 26, 36 AND 38).

FIRST USE 7-31-2010; IN COMMERCE 7-31-2010.

3,942,191. PC TREASURES, INC., OXFORD, MI. SN 85-048,578. PUB. 10-26-2010, FILED 5-26-2010.

**SLIPIT!**

THE MARK CONSISTS OF STANDARD CHARACTERS WITHOUT CLAIM TO ANY PARTICULAR FONT, STYLE, SIZE, OR COLOR.

FOR NETBOOK SLEEVES (U.S. CLS. 21, 23, 26, 36 AND 38).

FIRST USE 9-24-2010; IN COMMERCE 9-24-2010.

3,942,200. QEF DESIGN CORP., YONGHE CITY, TAIPEI CO, TAIWAN. SN 85-050,691. PUB. 11-2-2010, FILED 5-28-2010.



THE MARK CONSISTS OF AN ELLIPTICAL DESIGN COMPRISING TWO CURVED LINES ON EITHER SIDE OF A SLANTED MIDDLE VERTICAL LINE.

FOR EYEGLASSES, CONTACT LENS, SPECTACLES, EYEGLASS FRAMES, SPECTACLE FRAMES, EYEGLASS CASES, SPECTACLE CASES, CONTACT LENS CASES, EYEGLASS LENS, SPECTACLE LENS (U.S. CLS. 21, 23, 26, 36 AND 38).

FIRST USE 7-1-2006; IN COMMERCE 8-16-2010.

**CLASS 9—(Continued).**

3,942,212. T-MOBILE USA, INC., BELLEVUE, WA. SN 85-053,218. PUB. 12-7-2010, FILED 6-2-2010.



THE COLOR(S) PINK, ORANGE, GREEN, GREY AND BLACK IS/ARE CLAIMED AS A FEATURE OF THE MARK.

THE MARK CONSISTS OF THREE ROUNDED CORNER SQUARE SHAPES OVERLAPPING ONE ANOTHER INCLUDING A GREY SILHOUETTE OF A PERSON'S HEAD AND SHOULDERS. THE CENTER SQUARE HAS A PINK BACKGROUND, THE SQUARE BEHIND IT TO THE RIGHT HAS AN ORANGE BACKGROUND, AND THE THIRD SQUARE TO THE LEFT OF THE CENTER SQUARE HAS A GREEN BACKGROUND. THE OUTSIDE PERIMETERS OF THE SQUARES ARE GREY. THE SQUARES HAVE BLACK TRIM AT THE BOTTOM, WHICH CHANGES TO GREY AND THE TRIM CONTINUES AROUND THE SQUARE.

FOR COMPUTER APPLICATION SOFTWARE FOR WIRELESS TELECOMMUNICATIONS DEVICES, NAMELY, SOFTWARE FOR GRAPHICAL PRESENTATION OF CONTACTS, AND DEDICATED BUTTONS IN WIRELESS TELECOMMUNICATIONS DEVICES FOR THE GRAPHICAL PRESENTATION OF CONTACTS (U.S. CLS. 21, 23, 26, 36 AND 38).

FIRST USE 11-3-2010; IN COMMERCE 11-3-2010.

3,942,233. UNCOMMON, LLC, CHICAGO, IL. SN 85-057,018. PUB. 10-19-2010, FILED 6-8-2010.

**GALLERY**

THE MARK CONSISTS OF STANDARD CHARACTERS WITHOUT CLAIM TO ANY PARTICULAR FONT, STYLE, SIZE, OR COLOR.

FOR CARRYING CASES OR BAGS DESIGNED FOR STORAGE AND TRANSPORTATION OF CONSUMER ELECTRONICS, CELLULAR PHONES, MEDIA PLAYERS, AND LAPTOP COMPUTERS (U.S. CLS. 21, 23, 26, 36 AND 38).

FIRST USE 6-8-2010; IN COMMERCE 6-8-2010.

**CLASS 9—(Continued).**

3,942,238. TRANSFORMATION ASSOCIATES, INC., DBA PRECISEPROCESS, LEBANON, NJ. SN 85-060,522. PUB. 11-9-2010, FILED 6-11-2010.

precisePROCESS

THE MARK CONSISTS OF STANDARD CHARACTERS WITHOUT CLAIM TO ANY PARTICULAR FONT, STYLE, SIZE, OR COLOR.

FOR COMPUTER SOFTWARE FOR THE DEVELOPMENT AND CONFIGURATION OF WEB-BASED WORKFLOW MANAGEMENT APPLICATIONS (U.S. CLS. 21, 23, 26, 36 AND 38).

FIRST USE 7-13-2010; IN COMMERCE 7-13-2010.

3,942,243. NORTHERN SAFETY CO., INC., FRANKFORT, NY. SN 85-062,158. PUB. 11-16-2010, FILED 6-14-2010.

POLYFLEX

THE MARK CONSISTS OF STANDARD CHARACTERS WITHOUT CLAIM TO ANY PARTICULAR FONT, STYLE, SIZE, OR COLOR.

FOR PROTECTIVE GLOVES FOR INDUSTRIAL USE (U.S. CLS. 21, 23, 26, 36 AND 38).

FIRST USE 1-19-2011; IN COMMERCE 1-19-2011.

3,942,245. GRAND VISION GAMING, LLC, BILLINGS, MT. SN 85-063,687. PUB. 11-16-2010, FILED 6-15-2010.

PLENTY OF PENGUINS

THE MARK CONSISTS OF STANDARD CHARACTERS WITHOUT CLAIM TO ANY PARTICULAR FONT, STYLE, SIZE, OR COLOR.

FOR VIDEO GAMING MACHINES (U.S. CLS. 21, 26, 36 AND 38).

FIRST USE 8-0-2010; IN COMMERCE 8-0-2010.

**CLASS 9—(Continued).**

3,942,260. GREEN REWARDS & AFFINITY LLC, DBA ENABLE TABLE, GREENWICH, CT. SN 85-067,345. PUB. 12-7-2010, FILED 6-21-2010.

Enable Table

THE MARK CONSISTS OF STANDARD CHARACTERS WITHOUT CLAIM TO ANY PARTICULAR FONT, STYLE, SIZE, OR COLOR.

NO CLAIM IS MADE TO THE EXCLUSIVE RIGHT TO USE "TABLE", APART FROM THE MARK AS SHOWN.

FOR COMPUTER APPLICATION SOFTWARE FOR MOBILE PHONES, NAMELY, SOFTWARE FOR TABLE SERVICE RESTAURANTS TO PROVIDE CONSUMER COUPONS DOWNLOADED FROM A GLOBAL COMPUTER NETWORK (U.S. CLS. 21, 23, 26, 36 AND 38).

FIRST USE 6-1-2010; IN COMMERCE 9-18-2010.

3,942,274. AQUAFOLD INC., SUNNYVALE, CA. SN 85-072,849. PUB. 11-30-2010, FILED 6-28-2010.

AQUASCRIPT

THE MARK CONSISTS OF STANDARD CHARACTERS WITHOUT CLAIM TO ANY PARTICULAR FONT, STYLE, SIZE, OR COLOR.

FOR COMPUTER PROGRAMS FOR USE IN DEVELOPING AND EXECUTING OTHER COMPUTER PROGRAMS ON COMPUTERS AND COMPUTER NETWORKS, AND INSTRUCTION MANUALS SOLD THEREWITH; COMPUTER PROGRAMS FOR USE IN DATABASE MANAGEMENT, DATA QUERYING, DATABASE DATA IMPORT AND EXPORT OPERATIONS, DATA CONVERSION, EXTRACT, TRANSFER AND LOAD OPERATIONS, BUILDING REPORTS AND CHARTS, DATA GENERATION, AUTOMATED SOFTWARE TESTING, DATA SYNCHRONIZATION, CONFIGURATION MANAGEMENT; COMPUTER SOFTWARE FOR CONTROLLING AND MANAGING ACCESS SERVER APPLICATIONS; COMPUTER SOFTWARE FOR USE IN DEVELOPING INTERNET BASED SOFTWARE APPLICATIONS; COMPUTER SOFTWARE TO AUTOMATE DATA WAREHOUSING; ELECTRONIC PUBLICATIONS, NAMELY, MANUALS, SOFTWARE DOCUMENTATION, WHITEPAPERS, MAGAZINES, AND ARTICLES FEATURING SOFTWARE DESIGN AND DEVELOPMENT, DATABASE MANAGEMENT, DATA PROCESSING RECORDED ON COMPUTER MEDIA (U.S. CLS. 21, 23, 26, 36 AND 38).

FIRST USE 10-4-2010; IN COMMERCE 9-4-2010.

**CLASS 9—(Continued).**

3,942,283. THE TIFFEN COMPANY, LLC, HAUPPAUGE, NY.  
SN 85-074,504. PUB. 11-16-2010, FILED 6-30-2010.

**ZEPHYR**

THE MARK CONSISTS OF STANDARD CHARACTERS WITHOUT CLAIM TO ANY PARTICULAR FONT, STYLE, SIZE, OR COLOR.

FOR OPERATOR-SUPPORTED FILM AND VIDEO CAMERA STABILIZERS AND COMPONENTS THEREOF, NAMELY, VEST, MONITOR, POWER SUPPLY, ARTICULATED ARM, BOOM, POST, LIFT, GIMBAL, SPEAKER, INFRARED REMOTE, CONNECTOR AND CASE SOLD AS A UNIT (U.S. CLS. 21, 23, 26, 36 AND 38).  
FIRST USE 12-29-2010; IN COMMERCE 12-29-2010.

3,942,285. THE TIFFEN COMPANY, LLC, HAUPPAUGE, NY.  
SN 85-074,916. PUB. 11-16-2010, FILED 6-30-2010.

**SMOOTHEE**

THE MARK CONSISTS OF STANDARD CHARACTERS WITHOUT CLAIM TO ANY PARTICULAR FONT, STYLE, SIZE, OR COLOR.

FOR A CAMERA STAND IN THE NATURE OF A STABILIZER FOR USE WITH CELLULAR PHONES CONTAINING BUILT-IN CAMERAS WHICH TAKE STILL PHOTOS AND VIDEOS (U.S. CLS. 21, 23, 26, 36 AND 38).

FIRST USE 12-31-2010; IN COMMERCE 12-31-2010.

3,942,307. GRAND VISION GAMING, LLC, BILLINGS, MT.  
SN 85-084,853. PUB. 11-16-2010, FILED 7-14-2010.

**FEVER ACES**

THE MARK CONSISTS OF STANDARD CHARACTERS WITHOUT CLAIM TO ANY PARTICULAR FONT, STYLE, SIZE, OR COLOR.

NO CLAIM IS MADE TO THE EXCLUSIVE RIGHT TO USE "ACES", APART FROM THE MARK AS SHOWN.

FOR VIDEO GAMING MACHINES (U.S. CLS. 21, 23, 26, 36 AND 38).

FIRST USE 11-2-2010; IN COMMERCE 11-2-2010.

**CLASS 9—(Continued).**

3,942,308. GRAND VISION GAMING, LLC, BILLINGS, MT.  
SN 85-084,862. PUB. 11-16-2010, FILED 7-14-2010.

**LAST BLAST**

THE MARK CONSISTS OF STANDARD CHARACTERS WITHOUT CLAIM TO ANY PARTICULAR FONT, STYLE, SIZE, OR COLOR.

FOR VIDEO GAMING MACHINES (U.S. CLS. 21, 23, 26, 36 AND 38).

FIRST USE 11-2-2010; IN COMMERCE 11-2-2010.

3,942,309. GRAND VISION GAMING, LLC, BILLINGS, MT.  
SN 85-084,868. PUB. 11-16-2010, FILED 7-14-2010.

**ODD BALL**

THE MARK CONSISTS OF STANDARD CHARACTERS WITHOUT CLAIM TO ANY PARTICULAR FONT, STYLE, SIZE, OR COLOR.

FOR VIDEO GAMING MACHINES (U.S. CLS. 21, 23, 26, 36 AND 38).

FIRST USE 11-2-2010; IN COMMERCE 11-2-2010.

3,942,315. CADILLAC JACK, INC., DULUTH, GA. SN 85-096,275. PUB. 11-23-2010, FILED 7-29-2010.

**STRUCK BY LUCK**

THE MARK CONSISTS OF STANDARD CHARACTERS WITHOUT CLAIM TO ANY PARTICULAR FONT, STYLE, SIZE, OR COLOR.

FOR GAMING DEVICES, NAMELY, GAMING MACHINES, SLOT MACHINES, BINGO MACHINES, WITH OR WITHOUT VIDEO OUTPUT (U.S. CLS. 21, 23, 26, 36 AND 38).

FIRST USE 12-14-2010; IN COMMERCE 12-14-2010.

**CLASS 9—(Continued).**

3,942,317. GRAND VISION GAMING, LLC, BILLINGS, MT.  
SN 85-097,799. PUB. 11-16-2010, FILED 8-2-2010.

# POWER GRID

THE MARK CONSISTS OF STANDARD CHARACTERS WITHOUT CLAIM TO ANY PARTICULAR FONT, STYLE, SIZE, OR COLOR.  
FOR GAMING MACHINES (U.S. CLS. 21, 23, 26, 36 AND 38).  
FIRST USE 11-2-2010; IN COMMERCE 11-2-2010.

---

3,942,318. GRAND VISION GAMING, LLC, BILLINGS, MT.  
SN 85-099,341. PUB. 11-16-2010, FILED 8-3-2010.

# TROPICAL VACATION

THE MARK CONSISTS OF STANDARD CHARACTERS WITHOUT CLAIM TO ANY PARTICULAR FONT, STYLE, SIZE, OR COLOR.  
FOR GAMING MACHINES (U.S. CLS. 21, 23, 26, 36 AND 38).  
FIRST USE 11-2-2010; IN COMMERCE 11-2-2010.

---

**CLASS 10—MEDICAL APPARATUS**

3,941,015. SMITHS MEDICAL ASD, INC., KEENE, NH. SN 77-067,812. PUB. 1-8-2008, FILED 12-19-2006.

# EPIFUSE

THE MARK CONSISTS OF STANDARD CHARACTERS WITHOUT CLAIM TO ANY PARTICULAR FONT, STYLE, SIZE, OR COLOR.  
FOR MEDICAL DEVICES AND APPARATUS, NAMELY, CATHETERS AND PARTS AND FITTINGS THEREFOR (U.S. CLS. 26, 39 AND 44).  
FIRST USE 9-1-2010; IN COMMERCE 9-1-2010.

**CLASS 10—(Continued).**

3,941,134. NUVASIVE, INC., SAN DIEGO, CA. SN 77-574,918.  
PUB. 4-28-2009, FILED 9-19-2008.

# NVM5

THE MARK CONSISTS OF STANDARD CHARACTERS WITHOUT CLAIM TO ANY PARTICULAR FONT, STYLE, SIZE, OR COLOR.  
FOR SURGICAL APPARATUS FOR GUIDING SURGICAL PEDICLE PROBES, AWLS, TAPS, SCREWS, AND OTHER SURGICAL INSTRUMENTS; ELECTRONIC SPINAL CORD AND NERVE SURVEILLANCE AND DETECTION SYSTEMS COMPRISING CANNULAE, OBTURATORS, PEDICLE PROBES, AWLS, TAPS, ELECTRODES, SENSORS, STIMULATORS, DISPLAY SCREENS, CABLING, AND COMPUTER HARDWARE AND DEDICATED COMPUTER SOFTWARE FOR OPERATION THEREOF (U.S. CLS. 26, 39 AND 44).  
FIRST USE 3-24-2009; IN COMMERCE 3-24-2009.

---

3,941,259. HU-FRIEDY MFG. CO., LLC, CHICAGO, IL. SN 77-721,432. PUB. 4-13-2010, FILED 4-24-2009.

# SWERV

THE MARK CONSISTS OF STANDARD CHARACTERS WITHOUT CLAIM TO ANY PARTICULAR FONT, STYLE, SIZE, OR COLOR.  
FOR DENTAL EQUIPMENT ACCESSORIES, NAMELY, ULTRASONIC SCALERS AND HANDPIECES (U.S. CLS. 26, 39 AND 44).  
FIRST USE 4-1-2010; IN COMMERCE 4-1-2010.

---

3,941,364. MEDTRONIC, INC., MINNEAPOLIS, MN. SN 77-782,827. PUB. 11-30-2010, FILED 7-16-2009.

# CONTOUR 3D

THE MARK CONSISTS OF STANDARD CHARACTERS WITHOUT CLAIM TO ANY PARTICULAR FONT, STYLE, SIZE, OR COLOR.  
OWNER OF U.S. REG. NOS. 2,656,807 AND 3,473,054. SEC. 2(F) AS TO "3D".  
FOR CARDIAC SURGERY DEVICES, NAMELY, AN ANNULOPLASTY SYSTEM CONSISTING OF A BAND, RING, SIZER SET, ANNULOPLASTY HANDLE AND ACCESSORY TRAY (U.S. CLS. 26, 39 AND 44).  
FIRST USE 11-8-2010; IN COMMERCE 11-8-2010.

**CLASS 10—(Continued).**

3,941,405. STUART A. LINDER, BEVERLY HILLS, CA. SN 77-798,092. PUB. 6-1-2010, FILED 8-5-2009.

## DR.LINDERBRA

THE MARK CONSISTS OF STANDARD CHARACTERS WITHOUT CLAIM TO ANY PARTICULAR FONT, STYLE, SIZE, OR COLOR.

THE NAME(S), PORTRAIT(S), AND/OR SIGNATURE(S) SHOWN IN THE MARK IDENTIFIES "DR. STUART A. LINDER", WHOSE CONSENT(S) TO REGISTER IS MADE OF RECORD.

FOR POST SURGICAL GARMENTS AND DEVICES, NAMELY, BRAS TO BE USED FOLLOWING BREAST SURGERY (U.S. CLS. 26, 39 AND 44).

FIRST USE 12-31-2010; IN COMMERCE 12-31-2010.

3,941,435. VERIDIAN HEALTHCARE, LLC, WAUKEGAN, IL. SN 77-809,166. PUB. 6-29-2010, FILED 8-20-2009.



OWNER OF U.S. REG. NOS. 3,847,204, 3,847,205, AND 3,852,369.

THE MARK CONSISTS OF A STYLIZED PYRAMID DESIGN ADJACENT TO THE WORD "VERIDIAN".

FOR MEDICAL INSTRUMENTS, NAMELY, SPHYGMOMANOMETERS; STETHOSCOPES; NEUROLOGICAL HAMMERS FOR MEDICAL PURPOSES; BLOOD PRESSURE MEASURING APPARATUS, NAMELY, CUFFS; ANEROID GAUGES, NAMELY, MANOMETERS FOR MEDICAL PURPOSES; THERMOMETERS FOR MEDICAL PURPOSES; DIGITAL BLOOD PRESSURE MONITORS; SURGICAL BANDAGE SCISSORS FOR MEDICAL PURPOSES; PULSE MEASURING DEVICES, NAMELY, PULSE TIMERS; ELECTROCARDIOGRAM (ECG) CALLIPERS FOR MEDICAL PURPOSES; MEDICAL KITS FOR EMERGENCY MEDICAL TECHNICIANS AND NURSES CONSISTING OF BLOOD PRESSURE MONITORING APPARATUS AND A STETHOSCOPE (U.S. CLS. 26, 39 AND 44).

FIRST USE 5-31-2010; IN COMMERCE 5-31-2010.

**CLASS 10—(Continued).**

3,941,469. MARINE POLYMER TECHNOLOGIES, INC., DANVERS, MA. SN 77-830,058. PUB. 8-17-2010, FILED 9-18-2009.

## HEMOSTEER

THE MARK CONSISTS OF STANDARD CHARACTERS WITHOUT CLAIM TO ANY PARTICULAR FONT, STYLE, SIZE, OR COLOR.

FOR MEDICAL DEVICES, NAMELY, HEMOSTASIS VALVES (U.S. CLS. 26, 39 AND 44).

FIRST USE 12-0-2010; IN COMMERCE 12-0-2010.

3,941,481. SOS NOVELTIES, INC., PASADENA, CA. SN 77-838,558. PUB. 5-11-2010, FILED 9-30-2009.



THE MARK CONSISTS OF A STYLIZED IMAGE OF THE VENUS FEMALE GENDER SYMBOL WITH IN THE LETTER O IN THE MARK "SOS".

FOR GLASS DILDOS (U.S. CLS. 26, 39 AND 44).

FIRST USE 11-25-2010; IN COMMERCE 11-25-2010.

3,941,493. HORIAN, RICHARD, DBA BRUXCURE, CORONA, CA. SN 77-847,117. PUB. 3-16-2010, FILED 10-12-2009.

## Bruxcure

THE MARK CONSISTS OF STANDARD CHARACTERS WITHOUT CLAIM TO ANY PARTICULAR FONT, STYLE, SIZE, OR COLOR.

FOR MOUTH GUARDS FOR MEDICAL PURPOSES (U.S. CLS. 26, 39 AND 44).

FIRST USE 2-10-2010; IN COMMERCE 1-7-2011.

**CLASS 10—(Continued).**

3,941,541. STRYKER CORPORATION, KALAMAZOO, MI. SN 77-866,696. PUB. 10-19-2010, FILED 11-6-2009.

**RP 360°**

THE MARK CONSISTS OF STANDARD CHARACTERS WITHOUT CLAIM TO ANY PARTICULAR FONT, STYLE, SIZE, OR COLOR.

NO CLAIM IS MADE TO THE EXCLUSIVE RIGHT TO USE "360", APART FROM THE MARK AS SHOWN. FOR SURGICAL INSTRUMENTS, NAMELY, SUTURE PASSER AND NEEDLE (U.S. CLS. 26, 39 AND 44). FIRST USE 9-24-2010; IN COMMERCE 9-24-2010.

**CLASS 10—(Continued).**

3,941,943. HANGER PROSTHETICS & ORTHOTICS, INC., AUSTIN, TX. SN 77-947,080. PUB. 7-27-2010, FILED 3-1-2010.

**VAC-PIN**

THE MARK CONSISTS OF STANDARD CHARACTERS WITHOUT CLAIM TO ANY PARTICULAR FONT, STYLE, SIZE, OR COLOR.

FOR PROSTHETIC SOCKETS USED TO FASTEN PROSTHETIC LIMBS TO THE BODY (U.S. CLS. 26, 39 AND 44). FIRST USE 2-22-2010; IN COMMERCE 2-22-2010.

3,942,124. DB ORTHODONTICS LTD, SILSDEN, W. YORKSHIRE, UNITED KINGDOM. SN 85-023,107. PUB. 9-21-2010, FILED 4-26-2010.

3,941,683. TRANSENTERIX, INC., MORRISVILLE, NC. SN 77-898,909. PUB. 5-18-2010, FILED 12-22-2009.



THE MARK CONSISTS OF A SPIDER-LIKE DESIGN WITH FOUR LEGS IN A FORWARD POSITION AND TWO LEGS IN A REARWARD POSITION, ALL EXTENDING FROM A CIRCLE THAT IS LOCATED IN A REAR PORTION OF THE DESIGN.

FOR MEDICAL DEVICES, NAMELY, SURGICAL DEVICES FOR USE IN LAPAROSCOPIC PROCEDURES (U.S. CLS. 26, 39 AND 44). FIRST USE 9-1-2008; IN COMMERCE 9-9-2009.

THE MARK CONSISTS OF STANDARD CHARACTERS WITHOUT CLAIM TO ANY PARTICULAR FONT, STYLE, SIZE, OR COLOR.

FOR SURGICAL, MEDICAL, DENTAL AND VETERINARY APPARATUS AND INSTRUMENTS, NAMELY, PLIERS, SCREW DRIVERS, CUTTERS, FILES, GAUGES, BONE PUNCHES, MUCOTOMES, MUCOTOME BLADES, SCALPELS, RATCHETS, IMPLANT DRIVERS, FORCEPS, SURGICAL BLADES, DRILLS, AND REPLACEMENT PARTS THEREFOR; ORTHODONTIC ARTICLES FOR USE IN ORTHODONTIA AND ORAL SURGERY, NAMELY, DENTAL IMPLANTS, BRACES, BRACKETS, WIRES, LIGATURES, ARCHWIRE, HOOKS, SPRINGS, BANDS AND MOLAR BANDS, AND SCREWS AND DENTAL APPARATUS AND INSTRUMENTS FOR MANIPULATING, ATTACHING, DETACHING, ADJUSTING AND/OR OPENING THE AFOREMENTIONED ARTICLES, PARTICULARLY, CUTTERS, PLIERS, TWEEZERS, FORCEPS, LIGATURE TUCKERS, LIGATURE TIERS, LIGATURE DIRECTORS, BAND SEATING INSTRUMENTS, SCALERS, BAND PUSHERS, GAUGE CALIPERS, STRESS AND TENSION GAUGES, ARCH TURRETS, BRACKET POSITIONING TOOLS, DISPOSABLE BRUSHES, APPLICATION TOOLS FOR ADHESIVES, PICKS, BURRS, MIRRORS, AND STANDS, HOLDERS, AND BRACKETS SPECIFICALLY DESIGNED FOR ORGANIZING THE SAME; ORTHODONTIC APPLIANCES, BANDS, AND BRACKETS; DENTAL INSTRUMENTS FOR USE IN ORAL SURGERY AND ORTHODONTIA; SURGICAL AND MEDICAL APPARATUS AND INSTRUMENTS, NAMELY, BONE CUTTING FORCEPS, BONE HOLDING FORCEPS, BONE LEVERS, BONE RONGEURS, CHISELS, CHUCKS, CLAMPS, CURTTES, DISSECTING FORCEPS, DRILLS, DRIVERS, NAIL AND BONE ELEVATORS, EXTRACTORS, GOUGES, HOOKS, IMPACTORS, INTRODUCERS, KNIVES, MALLETS, NAIL GUIDES, PROBES, RETRACTORS, SHEARS, SPREADERS, STAPLE INSTRUMENTS, STAPLES, SUTURE SCISSORS, WIRE BENDERS AND WIRE CUTTERS; INSTRUMENTS FOR ORTHOPEDIC SURGERY AND CHIROPODY, NAMELY, NIPPERS, CANTILEVER NIPPERS, SCOPE AND SEEKERS, SYRINGE CARTRIDGES SOLD EMPTY, TOE SPREADERS,

**IXION**

**CLASS 10—(Continued).**

PLIERS, SCREW DRIVERS, CUTTERS, BONE PUNCHES, DISSECTORS, NAIL ELEVATORS, NAIL SPLITTERS, BONE CUTTING FORCEPS, BONE HOLDING FORCEPS, BONE LEVERS, BONE RONGEURS, CHISELS, CHUCKS, CLAMPS, CURETTES, DISSECTING FORCEPS, FILES, NEEDLE HOLDERS SPECIFICALLY DESIGNED FOR HOLDING NEEDLES, CUTICLE NIPPERS, SCALPELS, SCALPEL BLADES, PROBES, SPATULAS, GAUZE APPLICATORS, TWEEZERS, SCISSORS, DRILLS, DIAMOND BURS, TUNGSTEN BURS, DRIVERS, NAIL AND BONE ELEVATORS, EXTRACTORS, GOUGES, HOOKS, IMPACTORS, INTRODUCERS, KNIVES, MALLETS, NAIL GUIDES, SURGICAL TRAYS SPECIFICALLY DESIGNED FOR HOLDING SURGICAL INSTRUMENTS, SURGICAL KITS COMPRISED OF SURGICAL DEVICES AND INSTRUMENTS, CHIROPODY KITS COMPRISED OF SURGICAL DEVICES AND INSTRUMENTS, FORCEPS, GAUGES, PROBES, RETRACTORS, SHEARS, SPREADERS, STAPLE INSTRUMENTS, STAPLES, SUTURE SCISSORS, WIRE BENDERS AND WIRE CUTTERS (U.S. CLS. 26, 39 AND 44).  
FIRST USE 6-30-2004; IN COMMERCE 6-30-2004.

**CLASS 10—(Continued).**

3,942,237. WELLS LAMONT INDUSTRY GROUP LLC, NILES, IL. SN 85-059,720. PUB. 11-2-2010, FILED 6-10-2010.

**SCEPTER**

THE MARK CONSISTS OF STANDARD CHARACTERS WITHOUT CLAIM TO ANY PARTICULAR FONT, STYLE, SIZE, OR COLOR.  
FOR MEDICAL GLOVES (U.S. CLS. 26, 39 AND 44).  
FIRST USE 1-3-2003; IN COMMERCE 1-3-2003.

3,942,261. MEDTRONIC XOMED, INC., JACKSONVILLE, FL. SN 85-067,363. PUB. 9-28-2010, FILED 6-21-2010.

**QUADCUT**

THE MARK CONSISTS OF STANDARD CHARACTERS WITHOUT CLAIM TO ANY PARTICULAR FONT, STYLE, SIZE, OR COLOR.  
FOR SURGICAL BLADES (U.S. CLS. 26, 39 AND 44).  
FIRST USE 12-20-2010; IN COMMERCE 12-20-2010.

**CLASS 11—ENVIRONMENTAL CONTROL APPARATUS**

3,940,991. KEMCO SYSTEMS, INC., CLEARWATER, FL. SN 76-697,516. PUB. 5-25-2010, FILED 5-21-2009.



THE MARK CONSISTS OF THE STYLIZED WORDING "KEMCO K" SURROUNDED BY A CIRCLE FORMED BY TWO ARROWS.  
FOR WATER HEATERS; BOILER STACK ECONOMIZERS; WASTE WATER FILTRATION EQUIPMENT, NAMELY, CERAMIC MICROFILTRATION UNITS, AIR BACKWASHING FILTRATION UNITS AND NANO FILTRATION UNITS; WASTE WATER TREATMENT AND PURIFICATION EQUIPMENT FOR PROCESSING WASTE WATER, IRRIGATION WATER, OR POTABLE WATER, NAMELY, AIR SPARGED HYDROCYCLONE UNITS, DISSOLVED AIR FLOTATION UNITS AND INCLINED PLATE CLARIFIER UNITS; AND WATER STORAGE TANKS FOR USE WITH WATER FILTRATION SYSTEMS (U.S. CLS. 13, 21, 23, 31 AND 34).  
FIRST USE 12-31-1989; IN COMMERCE 12-31-1989.

3,942,232. GEORGE, MANSOUR J., LOSANGELES, CA. SN 85-056,809. PUB. 11-16-2010, FILED 6-7-2010.

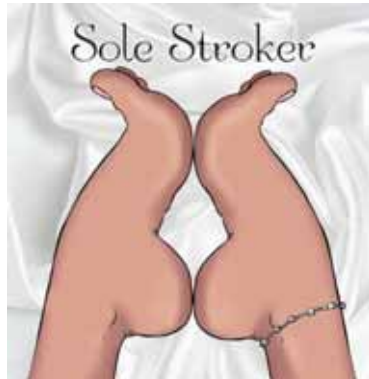

THE COLOR(S) GREY, BEIGE, BLACK, WHITE, AND PINK IS/ARE CLAIMED AS A FEATURE OF THE MARK.  
THE MARK CONSISTS OF THE FOLLOWING: THE WORDS "SOLE STROKER" IN BLACK ABOVE BEIGE FEET AND ANKLES, WITH THE SOLES TOUCHING OUTLINED IN BLACK WITH PINK TOENAILS. ON THE RIGHT ANKLE IS A BLACK ANKLET WITH WHITE CHARMS. THE BACKGROUND OF THE MARK IS A WHITE SHEET WITH GREY SHADOWING.  
FOR ADULT SEXUAL STIMULATION AIDS, NAMELY, ARTIFICIAL FEET (U.S. CLS. 26, 39 AND 44).  
FIRST USE 11-26-2009; IN COMMERCE 11-26-2009.



**CLASS 11—(Continued).**

3,941,005. FAN FI INTERNATIONAL, INC., SPARKS, NV. SN 76-703,396. PUB. 11-16-2010, FILED 6-16-2010.

**OXYGENICS VORTEX**

THE MARK CONSISTS OF STANDARD CHARACTERS WITHOUT CLAIM TO ANY PARTICULAR FONT, STYLE, SIZE, OR COLOR.

OWNER OF U.S. REG. NOS. 2,114,080 AND 3,709,028. FOR SHOWERHEADS (U.S. CLS. 13, 21, 23, 31 AND 34). FIRST USE 10-1-2010; IN COMMERCE 10-1-2010.

---

3,941,067. NII NORTHERN INTERNATIONAL INC., COQUITLAM, BC, CANADA. SN 77-391,078. PUB. 6-24-2008, FILED 2-7-2008.

**NIGHT SPLENDOR**

THE MARK CONSISTS OF STANDARD CHARACTERS WITHOUT CLAIM TO ANY PARTICULAR FONT, STYLE, SIZE, OR COLOR.

FOR ELECTRIC CANDLES (U.S. CLS. 13, 21, 23, 31 AND 34). FIRST USE 3-19-2010; IN COMMERCE 1-12-2011.

---

3,941,095. LES AGENCES CAOULAST, INC., GRANBY, CANADA. SN 77-499,922. PUB. 11-11-2008, FILED 6-16-2008.



THE COLOR(S) RED, WHITE AND BLACK IS/ARE CLAIMED AS A FEATURE OF THE MARK.

THE MARK CONSISTS OF THE WORD "COOK-AIR" IN WHITE LETTERS AGAINST A BLACK RECTANGULAR BACKGROUND OUTLINED IN THE COLOR RED; THE LETTER "I" IN THE WORD "AIR" IS IN THE FORM OF A RED-TIPPED FLAME.

FOR BARBECUES AND GRILLS (U.S. CLS. 13, 21, 23, 31 AND 34). FIRST USE 12-21-2010; IN COMMERCE 12-21-2010.

**CLASS 11—(Continued).**

3,941,272. VENTECH, LLC, WIXOM, MI. SN 77-737,313. PUB. 9-22-2009, FILED 5-14-2009.

**LHG**

THE MARK CONSISTS OF STANDARD CHARACTERS WITHOUT CLAIM TO ANY PARTICULAR FONT, STYLE, SIZE, OR COLOR.

FOR HEATING INSTALLATIONS; HEATING UNITS FOR LAND VEHICLES (U.S. CLS. 13, 21, 23, 31 AND 34). FIRST USE 0-0-1995; IN COMMERCE 0-0-1995.

---

3,941,273. VENTECH, LLC, WIXOM, MI. SN 77-737,316. PUB. 9-22-2009, FILED 5-14-2009.

**START THE ENGINE ... FEEL  
THE HEAT**

THE MARK CONSISTS OF STANDARD CHARACTERS WITHOUT CLAIM TO ANY PARTICULAR FONT, STYLE, SIZE, OR COLOR.

FOR HEATING INSTALLATIONS; HEATING UNITS FOR LAND VEHICLES (U.S. CLS. 13, 21, 23, 31 AND 34). FIRST USE 0-0-2003; IN COMMERCE 0-0-2003.

---

3,941,274. VENTECH, LLC, WIXOM, MI. SN 77-737,320. PUB. 9-22-2009, FILED 5-14-2009.

**TURNING YELLOW BUSES GREEN**

THE MARK CONSISTS OF STANDARD CHARACTERS WITHOUT CLAIM TO ANY PARTICULAR FONT, STYLE, SIZE, OR COLOR.

FOR HEATING INSTALLATIONS; HEATING UNITS FOR LAND VEHICLES (U.S. CLS. 13, 21, 23, 31 AND 34). FIRST USE 0-0-2008; IN COMMERCE 0-0-2008.

**CLASS 11—(Continued).**

3,941,320. DOUG ANDREWS HEATING & VENTILATION LIMITED, WHANGAREI, NEW ZEALAND. SN 77-764,708. PUB. 5-25-2010, FILED 6-22-2009.

**MULTI KAI COOKER**

THE MARK CONSISTS OF STANDARD CHARACTERS WITHOUT CLAIM TO ANY PARTICULAR FONT, STYLE, SIZE, OR COLOR.

NO CLAIM IS MADE TO THE EXCLUSIVE RIGHT TO USE "COOKER", APART FROM THE MARK AS SHOWN.

THE ENGLISH TRANSLATION OF THE WORD "KAI" IN THE MARK IS "FOOD".

FOR COOKING APPARATUS, NAMELY, PORTABLE BARBECUE COOKERS (U.S. CLS. 13, 21, 23, 31 AND 34). FIRST USE 12-1-1998; IN COMMERCE 10-1-2005.

---

3,941,357. HIGH TECH DESIGN SAFETY, LLC, AUSTIN, TX. SN 77-778,219. PUB. 10-26-2010, FILED 7-10-2009.

**FireFly LED Lighting**

THE MARK CONSISTS OF STANDARD CHARACTERS WITHOUT CLAIM TO ANY PARTICULAR FONT, STYLE, SIZE, OR COLOR.

NO CLAIM IS MADE TO THE EXCLUSIVE RIGHT TO USE "LED LIGHTING", APART FROM THE MARK AS SHOWN.

FOR ELECTRIC LIGHT BULBS (U.S. CLS. 13, 21, 23, 31 AND 34).

FIRST USE 7-24-2009; IN COMMERCE 11-0-2010.

---

3,941,487. MASCO BATH CORPORATION, MOORESTOWN, NJ. SN 77-841,322. PUB. 6-1-2010, FILED 10-5-2009.

**VESUVIA**

THE MARK CONSISTS OF STANDARD CHARACTERS WITHOUT CLAIM TO ANY PARTICULAR FONT, STYLE, SIZE, OR COLOR.

THE WORDING "VESUVIA" HAS NO MEANING IN A FOREIGN LANGUAGE.

FOR PREFORMED BATH SURROUNDS, PREFORMED SHOWER SURROUNDS AND PREFORMED SHOWER BASES (U.S. CLS. 13, 21, 23, 31 AND 34).

FIRST USE 1-14-2010; IN COMMERCE 1-14-2010.

**CLASS 11—(Continued).**

3,941,533. BUNN-O-MATIC CORPORATION, SPRINGFIELD, IL. SN 77-864,577. PUB. 6-15-2010, FILED 11-4-2009.

**TRIFECTA**

THE MARK CONSISTS OF STANDARD CHARACTERS WITHOUT CLAIM TO ANY PARTICULAR FONT, STYLE, SIZE, OR COLOR.

FOR ELECTRIC BEVERAGE MAKERS, NAMELY, COFFEE MAKERS, TEA MAKERS, AND HOT BEVERAGE MAKERS FOR DOMESTIC AND COMMERCIAL USE, AND STRUCTURAL REPLACEMENT PARTS THEREFOR (U.S. CLS. 13, 21, 23, 31 AND 34).

FIRST USE 5-20-2010; IN COMMERCE 5-20-2010.

---

3,941,635. MJSI, INC., SHOREWOOD, IL. SN 77-892,463. PUB. 5-11-2010, FILED 12-14-2009.

**HYDROSMART**

THE MARK CONSISTS OF STANDARD CHARACTERS WITHOUT CLAIM TO ANY PARTICULAR FONT, STYLE, SIZE, OR COLOR.

FOR PARTS FOR TOILETS, NAMELY, TOILET FILL VALVES, TOILET FLUSH VALVES, TOILET FLAPPERS, TOILET DUAL FLUSH CONVERTERS, TOILET FLUSH HANDLES, AND TOILET FLUSH BUTTONS (U.S. CLS. 13, 21, 23, 31 AND 34).

FIRST USE 11-1-2010; IN COMMERCE 11-1-2010.

---

3,941,688. ADVANCED NUTRIENTS LTD., ABBOTSFORD, BC, CANADA. SN 77-899,582. PUB. 11-9-2010, FILED 12-22-2009.

**COOLFLAME**

THE MARK CONSISTS OF STANDARD CHARACTERS WITHOUT CLAIM TO ANY PARTICULAR FONT, STYLE, SIZE, OR COLOR.

PRIORITY CLAIMED UNDER SEC. 44(D) ON CANADA APPLICATION NO. 1461461, FILED 12-3-2009, REG. NO. TMA775756, DATED 8-27-2010, EXPIRES 8-27-2025.

FOR CARBON DIOXIDE GENERATOR (U.S. CLS. 13, 21, 23, 31 AND 34).

FIRST USE 12-0-2009; IN COMMERCE 12-0-2009.

**CLASS 11—(Continued).**

3,941,689. ADVANCED NUTRIENTS LTD., ABBOTSFORD, BC, CANADA. SN 77-899,603. PUB. 11-9-2010, FILED 12-22-2009.

**ICE FLOW**

THE MARK CONSISTS OF STANDARD CHARACTERS WITHOUT CLAIM TO ANY PARTICULAR FONT, STYLE, SIZE, OR COLOR.

PRIORITY CLAIMED UNDER SEC. 44(D) ON CANADA APPLICATION NO. 1461459, FILED 12-3-2009, REG. NO. TMA775760, DATED 8-27-2010, EXPIRES 8-27-2025.

FOR WATER-BASED COOLING SYSTEM FOR USE IN GROWING PLANTS (U.S. CLS. 13, 21, 23, 31 AND 34).  
FIRST USE 12-0-2009; IN COMMERCE 12-0-2009.

3,941,701. X2O FILTRATION, ALAMOGORDO, NM. SN 77-901,361. PUB. 11-23-2010, FILED 12-28-2009.

**watermate**

THE MARK CONSISTS OF THE STYLIZED TEXT "WATERMATE" WITH A CROSS IN PLACE OF THE FIRST "T".

FOR SOLAR-POWERED, TRANSPORTABLE, SELF-CONTAINED WATER PURIFICATION AND FILTRATION APPARATUS THAT TURNS DIRTY WATER INTO POTABLE DRINKING WATER (U.S. CLS. 13, 21, 23, 31 AND 34).

FIRST USE 6-24-2010; IN COMMERCE 6-24-2010.

3,941,762. KEURIG, INCORPORATED, READING, MA. SN 77-912,957. PUB. 6-1-2010, FILED 1-15-2010.

**KEURIG BREWED**

THE MARK CONSISTS OF STANDARD CHARACTERS WITHOUT CLAIM TO ANY PARTICULAR FONT, STYLE, SIZE, OR COLOR.

OWNER OF U.S. REG. NOS. 2,057,361, 2,933,253, AND OTHERS.

NO CLAIM IS MADE TO THE EXCLUSIVE RIGHT TO USE "BREWED", APART FROM THE MARK AS SHOWN.

**CLASS 11—(Continued).**

THE ENGLISH TRANSLATION OF "KEURIG" IN THE MARK IS "NEAT".

FOR ELECTRIC COFFEE, TEA AND HOT COCOA BREWING MACHINES FOR DOMESTIC AND COMMERCIAL USE (U.S. CLS. 13, 21, 23, 31 AND 34).  
FIRST USE 11-0-2004; IN COMMERCE 11-0-2004.

3,941,782. USAI, LLC, NEW WINDSOR, NY. SN 77-915,748. PUB. 6-1-2010, FILED 1-20-2010.

**NANOLED**

THE MARK CONSISTS OF STANDARD CHARACTERS WITHOUT CLAIM TO ANY PARTICULAR FONT, STYLE, SIZE, OR COLOR.

FOR LIGHTING FIXTURES (U.S. CLS. 13, 21, 23, 31 AND 34).

FIRST USE 9-30-2010; IN COMMERCE 9-30-2010.

3,941,830. SUNBEAM PRODUCTS, INC., BOCA RATON, FL. SN 77-922,031. PUB. 6-15-2010, FILED 1-28-2010.

**Sunbeam**

OWNER OF U.S. REG. NOS. 429,134, 1,937,096, AND OTHERS.

THE MARK CONSISTS OF THE LITERAL ELEMENT "SUNBEAM" WITH AN ARCH HAVING TAPERED ENDS WITH ONE TAPERED END CONNECTED TO THE TOP OF THE "S" IN THE LITERAL ELEMENT AND EXTENDING ACROSS THE TOP OF THE ENTIRE LITERAL ELEMENT.

FOR ELECTRICAL COOLING APPARATUS FOR HOUSEHOLD USE, NAMELY, REFRIGERATORS, KEG COOLERS, BEVERAGE COOLERS, WINE COOLERS, ICE MAKERS, FREEZERS, AND PARTS AND ACCESSORIES THERETO (U.S. CLS. 13, 21, 23, 31 AND 34).

FIRST USE 7-9-2009; IN COMMERCE 7-9-2009.

3,941,854. SPECIALTY FABRICATION, LLC, PALOS VERDES PENINSULA, CA. SN 77-926,978. PUB. 8-3-2010, FILED 2-3-2010.

**HOT WATER PRO**

THE MARK CONSISTS OF STANDARD CHARACTERS WITHOUT CLAIM TO ANY PARTICULAR FONT, STYLE, SIZE, OR COLOR.

**CLASS 11—(Continued).**

NO CLAIM IS MADE TO THE EXCLUSIVE RIGHT TO USE "HOT WATER", APART FROM THE MARK AS SHOWN.

FOR HOT WATER CIRCULATION SYSTEMS FOR THE CIRCULATION OF HOT WATER IN PIPES COMPRISED OF WATER HEATERS, PIPES, WATER CIRCULATION PUMPS, TIMERS AND THERMOSTATS SOLD TOGETHER AS A UNIT (U.S. CLS. 13, 21, 23, 31 AND 34).  
FIRST USE 7-8-2010; IN COMMERCE 7-8-2010.

---

3,941,863. PHILLIPS, CURTIS, CHATTANOOGA, TN. SN 77-928,274. PUB. 6-22-2010, FILED 2-4-2010.

**SK8GLO**

THE MARK CONSISTS OF STANDARD CHARACTERS WITHOUT CLAIM TO ANY PARTICULAR FONT, STYLE, SIZE, OR COLOR.

FOR CHEMICALLY-ACTIVATED LIGHT STICKS; CHEMICALLY-ACTIVATED LIGHT STICKS AND LIGHT STICK MOUNTING BRACKETS FOR SKATEBOARDS, SOLD TOGETHER AS A UNIT (U.S. CLS. 13, 21, 23, 31 AND 34).

FIRST USE 5-21-2010; IN COMMERCE 5-21-2010.

---

3,941,898. EXCELL MARBLE AND GRANITE, INC., ST. PETERSBURG, FL. SN 77-934,519. PUB. 7-6-2010, FILED 2-12-2010.

**DAVOS**

THE MARK CONSISTS OF STANDARD CHARACTERS WITHOUT CLAIM TO ANY PARTICULAR FONT, STYLE, SIZE, OR COLOR.

FOR FAUCETS; PLUMBING FIXTURES, NAMELY, SHOWER SPRAYERS; PLUMBING FIXTURES, NAMELY, SINK SPRAYERS; SINKS (U.S. CLS. 13, 21, 23, 31 AND 34).

FIRST USE 5-31-2010; IN COMMERCE 5-31-2010.

**CLASS 11—(Continued).**

3,941,923. MOEN INCORPORATED, NORTH OLMSTED, OH. SN 77-943,405. PUB. 8-24-2010, FILED 2-24-2010.

**SPOT  
RESIST**



NO CLAIM IS MADE TO THE EXCLUSIVE RIGHT TO USE "SPOT RESIST", APART FROM THE MARK AS SHOWN.

THE MARK CONSISTS OF "SPOT RESIST" WHEREIN THE "O" OF THE WORD SPOT CONSTITUTES A THUMB-PRINT DESIGN.

FOR FAUCETS, NAMELY, LAVATORY FAUCETS, KITCHEN FAUCETS, ROMAN TUB FAUCETS AND FAUCET HANDLES; SHOWER AND TUB FIXTURES, NAMELY, TUB SPOUTS, SHOWER HEADS, HAND HELD SHOWER HEADS, AND SLIDE BARS THEREFOR; SHOWER VALVES, TUB/SHOWER VALVES; AND PLUMBING ACCESSORIES, NAMELY, FAUCET SPRAYERS AND KITCHEN SINK SIDE SPRAYERS (U.S. CLS. 13, 21, 23, 31 AND 34).

FIRST USE 6-17-2010; IN COMMERCE 6-17-2010.

---

3,942,106. SEA BOX, INC., RIVERTON, NJ. SN 85-014,583. PUB. 10-5-2010, FILED 4-15-2010.

**COLD STORAGE? GO!**



NO CLAIM IS MADE TO THE EXCLUSIVE RIGHT TO USE "COLD STORAGE", APART FROM THE MARK AS SHOWN.

THE COLOR(S) BLUE, TURQUOISE, BLACK, GRAY AND WHITE IS/ARE CLAIMED AS A FEATURE OF THE MARK.

THE MARK CONSISTS OF THE WORDS "COLD STORAGE" IN LIGHT BLUE OUTLINED IN WHITE AND DARK BLUE FOLLOWED BY THE NUMERAL "2" IN BLUE OUTLINED IN WHITE AND DARK BLUE FOLLOWED BY THE WORD "GO" IN TURQUOISE OUTLINED IN WHITE AND DARK BLUE FOLLOWED BY THE FANCIFUL CONFIGURATION OF A THERMOMETER OUTLINED IN GRAY WITH DARK BLUE FLUID INSIDE AND A SNOWFLAKE IN LIGHT BLUE ON TOP WITH ICICLES HANGING OFF OF THE BOTTOM IN LIGHT BLUE AND THE WORDS "BY SEA BOX" PRINTED IN WHITE IN THE BOTTOM PORTION OF THE "2".

FOR REFRIGERATED SHIPPING CONTAINERS (U.S. CLS. 13, 21, 23, 31 AND 34).

FIRST USE 8-31-2010; IN COMMERCE 8-31-2010.

**CLASS 11—(Continued).**

3,942,136. PURAFLOW, INC., TEMECULA, CA. SN 85-027,255. PUB. 10-5-2010, FILED 4-30-2010.

**ENVIRASPRING**

THE MARK CONSISTS OF STANDARD CHARACTERS WITHOUT CLAIM TO ANY PARTICULAR FONT, STYLE, SIZE, OR COLOR.

FOR WATER FILTRATION EQUIPMENT, NAMELY, REVERSE OSMOSIS FILTRATION UNITS AND COMPONENTS UTILIZED THEREWITH, NAMELY, MEMBRANES, MEMBRANE HOUSINGS, FILTERS, AND FILTER CARTRIDGES (U.S. CLS. 13, 21, 23, 31 AND 34).  
FIRST USE 6-16-2010; IN COMMERCE 6-16-2010.

3,942,266. COLUMBUS INDUSTRIES, INC., ASHVILLE, OH. SN 85-070,502. PUB. 11-16-2010, FILED 6-24-2010.

**SURE-STOP AM**

THE MARK CONSISTS OF STANDARD CHARACTERS WITHOUT CLAIM TO ANY PARTICULAR FONT, STYLE, SIZE, OR COLOR.

FOR RESIDENTIAL AND INDUSTRIAL HEATING VENTILATION AND AIR CONDITIONING SYSTEM AIR FILTERS (U.S. CLS. 13, 21, 23, 31 AND 34).

FIRST USE 12-14-2010; IN COMMERCE 12-14-2010.

**CLASS 12—VEHICLES**

3,941,310. GALATI, DANIEL, CHESTERFIELD, MO. SN 77-763,448. PUB. 11-10-2009, FILED 6-18-2009.

**TRAMP STAMP**

THE MARK CONSISTS OF STANDARD CHARACTERS WITHOUT CLAIM TO ANY PARTICULAR FONT, STYLE, SIZE, OR COLOR.

FOR MOTORCYCLE PARTS, NAMELY, SEATS, SEAT MOUNTS, SISSY BAR HANDLEBARS, FENDER BUMPERS AND SADDLE BAGS; MOTORCYCLE ACCESSORIES, NAMELY, FRONT AND SIDE PLATES; REPLACEMENT PARTS FOR ALL THE FOREGOING (U.S. CLS. 19, 21, 23, 31, 35 AND 44).  
FIRST USE 1-1-2011; IN COMMERCE 1-1-2011.

**CLASS 12—(Continued).**

3,941,344. CHRYSLER GROUP LLC, AUBURN HILLS, MI. SN 77-773,411. PUB. 5-11-2010, FILED 7-2-2009.



OWNER OF U.S. REG. NO. 2,357,408.  
THE MARK CONSISTS OF THE WORD "CHRYSLER" AND WING DESIGN.

FOR PASSENGER MOTOR VEHICLES, NAMELY, AUTOMOBILES AND VANS, AND STRUCTURAL PARTS, ENGINES AND BADGES THEREFORE (U.S. CLS. 19, 21, 23, 31, 35 AND 44).

FIRST USE 11-0-2010; IN COMMERCE 11-0-2010.

3,942,111. WAH HUNG INTERNATIONAL MACHINERY, INC., MONTEREY PARK, CA. SN 85-016,225. PUB. 9-28-2010, FILED 4-16-2010.



NO CLAIM IS MADE TO THE EXCLUSIVE RIGHT TO USE "WHEEL", APART FROM THE MARK AS SHOWN.

THE COLOR(S) GREEN, ORANGE, BLACK, BLUE, LIGHT-MAUVE, GRAY AND WHITE IS/ARE CLAIMED AS A FEATURE OF THE MARK.

THE MARK CONSISTS OF A LOGO CONSISTING OF A GREEN COLORED IRREGULAR HEXAGON FORMED BY A TRAPEZOID WITH TRUNCATED UPPER CORNERS HAVING A BORDER OUTLINED IN BLACK WITH LIGHT-MAUVE, GRAY AND WHITE SHADING. THE IRREGULAR HEXAGON IS DIVIDED TWICE BY BLACK LINES INTO THREE-SECTIONS IN A COLUMN. THE ORANGE COLORED WORDS "PHINO" AND "WHEEL" ARE IN THE TOP SECTION AND THE BOTTOM SECTION RESPECTIVELY, AND BETWEEN THEM IN THE MIDDLE SECTION IS A BLUE COLORED LETTER "P" AND A SWOOSH APPEARING IN THE COLORS LIGHT-MAUVE, GRAY AND WHITE OVER-FILLING THE CENTER BLANK SPACE OF THE LETTER "P".

FOR VEHICLE WHEEL RIMS (U.S. CLS. 19, 21, 23, 31, 35 AND 44).

FIRST USE 7-31-2010; IN COMMERCE 7-31-2010.

**CLASS 12—(Continued).**

3,942,282. THOR TECH, INC., JACKSON CENTER, OH. SN 85-073,919. PUB. 10-19-2010, FILED 6-29-2010.

**CLASS 13—(Continued).**

3,941,312. LOUISIANA AMMUNITION COMPANY, L.L.C., LAFAYETTE, LA. SN 77-763,616. PUB. 11-3-2009, FILED 6-19-2009.

**REDWOOD**

THE MARK CONSISTS OF STANDARD CHARACTERS WITHOUT CLAIM TO ANY PARTICULAR FONT, STYLE, SIZE, OR COLOR.  
FOR RECREATIONAL VEHICLES, NAMELY, FIFTH WHEEL TRAILERS (U.S. CLS. 19, 21, 23, 31, 35 AND 44).  
FIRST USE 11-0-2010; IN COMMERCE 11-0-2010.

**GOT'EM**

THE MARK CONSISTS OF STANDARD CHARACTERS WITHOUT CLAIM TO ANY PARTICULAR FONT, STYLE, SIZE, OR COLOR.  
FOR SHOTGUN CARTRIDGES; SHOTGUN SHELLS (U.S. CLS. 2 AND 9).  
FIRST USE 10-24-2010; IN COMMERCE 10-24-2010.

**CLASS 13—FIREARMS**

3,941,308. LOUISIANA AMMUNITION COMPANY, L.L.C., LAFAYETTE, LA. SN 77-762,056. PUB. 11-3-2009, FILED 6-17-2009.

3,941,404. ALLIANT TECHSYSTEMS INC., MINNEAPOLIS, MN. SN 77-797,253. PUB. 6-8-2010, FILED 8-5-2009.

**SPECTRA SHOT**

THE MARK CONSISTS OF STANDARD CHARACTERS WITHOUT CLAIM TO ANY PARTICULAR FONT, STYLE, SIZE, OR COLOR.  
FOR SHOTGUN SHELLS (U.S. CLS. 2 AND 9).  
FIRST USE 10-24-2010; IN COMMERCE 10-24-2010.

**EXTRA-LITE**

THE MARK CONSISTS OF STANDARD CHARACTERS WITHOUT CLAIM TO ANY PARTICULAR FONT, STYLE, SIZE, OR COLOR.  
OWNER OF U.S. REG. NOS. 1,567,701 AND 2,017,887. SEC. 2(F).  
FOR SHOTGUN POWDER (U.S. CLS. 2 AND 9).  
FIRST USE 6-0-2010; IN COMMERCE 6-0-2010.

3,941,311. LOUISIANA AMMUNITION COMPANY, L.L.C., LAFAYETTE, LA. SN 77-763,613. PUB. 11-3-2009, FILED 6-19-2009.

3,941,607. INGRAM ENTERPRISES, INC., SPRINGFIELD, MO. SN 77-883,161. PUB. 4-27-2010, FILED 12-1-2009.

**I GOT IT**

THE MARK CONSISTS OF STANDARD CHARACTERS WITHOUT CLAIM TO ANY PARTICULAR FONT, STYLE, SIZE, OR COLOR.  
FOR SHOTGUN CARTRIDGES; SHOTGUN SHELLS (U.S. CLS. 2 AND 9).  
FIRST USE 10-24-2010; IN COMMERCE 10-24-2010.

**RECKLESS RIOT**

THE MARK CONSISTS OF STANDARD CHARACTERS WITHOUT CLAIM TO ANY PARTICULAR FONT, STYLE, SIZE, OR COLOR.  
FOR FIREWORKS IN SHELL FORMS (U.S. CLS. 2 AND 9).  
FIRST USE 11-10-2010; IN COMMERCE 11-10-2010.

**CLASS 13—(Continued).**

3,942,063. SPRINGFIELD, INC., GENESEO, IL. SN 78-849,715.  
PUB. 11-20-2007, FILED 3-30-2006.

# 11 GEAR

THE MARK CONSISTS OF STANDARD CHARACTERS WITHOUT CLAIM TO ANY PARTICULAR FONT, STYLE, SIZE, OR COLOR.

NO CLAIM IS MADE TO THE EXCLUSIVE RIGHT TO USE "GEAR", APART FROM THE MARK AS SHOWN.  
FOR FIREARM ACCESSORIES, NAMELY, HOLSTERS, MAGAZINE POUCHES (U.S. CLS. 2 AND 9).  
FIRST USE 11-0-2006; IN COMMERCE 11-0-2006.

**CLASS 14—(Continued).**

3,941,084. BURKHART, ALAN KEITH, VAN BUREN, AR. SN 77-468,732. PUB. 10-14-2008, FILED 5-7-2008.

# \$1 JEWELRY GALORE!

THE MARK CONSISTS OF STANDARD CHARACTERS WITHOUT CLAIM TO ANY PARTICULAR FONT, STYLE, SIZE, OR COLOR.

NO CLAIM IS MADE TO THE EXCLUSIVE RIGHT TO USE "\$1 JEWELRY", APART FROM THE MARK AS SHOWN.  
FOR WATCHES (U.S. CLS. 2, 27, 28 AND 50).  
FIRST USE 4-1-2007; IN COMMERCE 4-1-2007.

**CLASS 14—JEWELRY**

3,941,014. INVICTA WATCH COMPANY OF AMERICA, INC., HOLLYWOOD, FL. SN 77-057,017. PUB. 6-1-2010, FILED 12-5-2006.

# THE CROSS FIRE

THE MARK CONSISTS OF STANDARD CHARACTERS WITHOUT CLAIM TO ANY PARTICULAR FONT, STYLE, SIZE, OR COLOR.

FOR WATCHES (U.S. CLS. 2, 27, 28 AND 50).  
FIRST USE 1-1-2011; IN COMMERCE 1-1-2011.

3,941,170. VICTORINOX SWISS ARMY, INC., MONROE, CT. SN 77-626,255. PUB. 7-20-2010, FILED 12-4-2008.

# MAVERICK

THE MARK CONSISTS OF STANDARD CHARACTERS WITHOUT CLAIM TO ANY PARTICULAR FONT, STYLE, SIZE, OR COLOR.

FOR WATCHES (U.S. CLS. 2, 27, 28 AND 50).  
FIRST USE 3-30-2000; IN COMMERCE 3-30-2000.

3,941,042. JERANKO, KAREN D., WESTMINSTER, CO. SN 77-258,025. PUB. 8-24-2010, FILED 8-17-2007.

# Be Inspired Jewelry

THE MARK CONSISTS OF STANDARD CHARACTERS WITHOUT CLAIM TO ANY PARTICULAR FONT, STYLE, SIZE, OR COLOR.

NO CLAIM IS MADE TO THE EXCLUSIVE RIGHT TO USE "JEWELRY", APART FROM THE MARK AS SHOWN.  
FOR CHARMS; JEWELRY (U.S. CLS. 2, 27, 28 AND 50).  
FIRST USE 5-1-2008; IN COMMERCE 5-1-2008.

3,941,181. AMERICAN JEWELRY MFG, INC., NEW YORK, NY. SN 77-634,646. PUB. 5-25-2010, FILED 12-16-2008.



NO CLAIM IS MADE TO THE EXCLUSIVE RIGHT TO USE "MEN'S JEWELRY", APART FROM THE MARK AS SHOWN.

THE MARK CONSISTS OF THE IMAGE OF A FACE WITH A CROWN TOPPED BY A DIAMOND, WITH THE WORDING "BLACKJACK" AND "MEN'S JEWELRY" APPEARING UNDERNEATH IT.

FOR BRACELETS; JEWELRY; STAINLESS STEEL JEWELRY BRACELETS (U.S. CLS. 2, 27, 28 AND 50).  
FIRST USE 10-15-2010; IN COMMERCE 10-15-2010.

**CLASS 14—(Continued).**

3,941,252. COLORE ACCESORIOS S. DE R. L DE C.V., GUADALAJARA, MEXICO. SN 77-711,591. PUB. 8-31-2010, FILED 4-10-2009.



OWNER OF MEXICO REG. NO. 1034553, DATED 1-24-2008, EXPIRES 1-24-2018.

THE COLOR(S) RED, YELLOW, GREEN, ORANGE, BLUE, PURPLE, AND WHITE IS/ARE CLAIMED AS A FEATURE OF THE MARK.

THE MARK CONSISTS OF A STYLIZED WORDING "SANTA MANIA" COLORED IN RED "S", YELLOW "A" CONTAINING A BLUE SMILEY FACE, BLUE "N", GREEN "T" DEPICTED AS A STEM WITH A YELLOW FLOWER WITH WHITE AND RED CENTER, ORANGE "A" CONTAINING A BLUE SMILEY FACE, BLUE "M", GREEN "A" CONTAINING A SOLID RED HEART, ORANGE "N", PURPLE "I" DOTTED WITH A YELLOW SUN, AND ORANGE "A" CONTAINING A BLUE SMILEY FACE.

THE ENGLISH TRANSLATION OF "SANTA MANIA" IN THE MARK IS "SAINT MANIA".

FOR (BASED ON FOREIGN REGISTRATION NO. 1034553) BODY JEWELRY, BRACELETS, EARRINGS, JEWEL PENDANTS, JEWEL CHAINS, JEWELRY FOR ATTACHMENT TO CLOTHING, JEWELRY PINS FOR USE ON HATS, KEY HOLDERS OF PRECIOUS METALS, NECKLACES, PENDANTS, PLASTIC BRACELETS IN THE NATURE OF JEWELRY, RINGS, RUBBER OR SILICON WRISTBANDS IN THE NATURE OF A BRACELET, AND WATCHES; FIGURES OF PRECIOUS METAL, JEWEL CASES, MEDALS AND MEDALLIONS (U.S. CLS. 2, 27, 28 AND 50).

FIRST USE 1-24-2008; IN COMMERCE 7-31-2010.

3,941,298. SANDBERG & SIKORSKI CORPORATION, NEW YORK, NY. SN 77-757,733. PUB. 9-29-2009, FILED 6-11-2009.

**LA BELLE FEMME**

THE MARK CONSISTS OF STANDARD CHARACTERS WITHOUT CLAIM TO ANY PARTICULAR FONT, STYLE, SIZE, OR COLOR.

THE ENGLISH TRANSLATION OF "LA BELLE FEMME" IN THE MARK IS "THE BEAUTIFUL WOMAN".

FOR JEWELRY (U.S. CLS. 2, 27, 28 AND 50).  
FIRST USE 12-10-2010; IN COMMERCE 12-10-2010.

**CLASS 14—(Continued).**

3,941,368. LUMINIAH DESIGNS CORPORATION, CANYON COUNTRY, CA. SN 77-783,227. PUB. 11-24-2009, FILED 7-16-2009.

**PROTECT THIS . . .**

THE MARK CONSISTS OF STANDARD CHARACTERS WITHOUT CLAIM TO ANY PARTICULAR FONT, STYLE, SIZE, OR COLOR.

FOR BRACELETS; BROACHES; CHARMS; CUFF LINKS AND TIE CLIPS; EARRINGS; JEWELRY; LOCKETS; NECKLACES; PET JEWELRY; RINGS (U.S. CLS. 2, 27, 28 AND 50).

FIRST USE 2-1-2011; IN COMMERCE 2-1-2011.

3,941,498. WONG, DAVID T., WALNUT, CA. SN 77-849,150. PUB. 4-6-2010, FILED 10-15-2009.



THE COLOR(S) SILVER, GOLD, BLACK AND WHITE IS/ARE CLAIMED AS A FEATURE OF THE MARK.

THE MARK CONSISTS OF A SILVER EAGLE AND A GOLD CROWN CIRCLED WITH A GOLD LEAVED WREATH IN THE MIDDLE OF THE EAGLE. THE WORDING "UBI UNIQUE BOURGEOIS INSTRUMENT" AND THE OUTLINE OF THE EAGLE AND THE OUTLINE OF THE CROWN ARE IN BLACK. THE BACKGROUND OF THE MARK IS IN WHITE.

FOR JEWELLERY AND WATCHES (U.S. CLS. 2, 27, 28 AND 50).

FIRST USE 1-1-2010; IN COMMERCE 10-1-2010.



**CLASS 14—(Continued).**

3,941,609. HARPS, LAQUINTA, SAINT JOHNS, FL. SN 77-883,363. PUB. 4-27-2010, FILED 12-1-2009.

# Baleijo

THE MARK CONSISTS OF STANDARD CHARACTERS WITHOUT CLAIM TO ANY PARTICULAR FONT, STYLE, SIZE, OR COLOR.

THE NAME "BALEIJO" DOES NOT IDENTIFY A LIVING INDIVIDUAL.

THE WORDING "BALEIJO" HAS NO MEANING IN A FOREIGN LANGUAGE.

FOR JEWELRY (U.S. CLS. 2, 27, 28 AND 50).  
FIRST USE 12-1-2009; IN COMMERCE 12-1-2009.

**CLASS 14—(Continued).**

3,941,948. INTERNATIONAL BULLION & METAL BROKERS (USA) INC., SUNRISE, FL. SN 77-949,339. PUB. 6-8-2010, FILED 3-3-2010.

# INDIVIDUALITY BEADS

THE MARK CONSISTS OF STANDARD CHARACTERS WITHOUT CLAIM TO ANY PARTICULAR FONT, STYLE, SIZE, OR COLOR.

NO CLAIM IS MADE TO THE EXCLUSIVE RIGHT TO USE "BEADS", APART FROM THE MARK AS SHOWN.

FOR JEWELRY, NAMELY, BRACELETS, BANGLES, NECKLACES, CHARMS, EARRINGS, RINGS, PINS, MADE OF PRECIOUS, SEMI-PRECIOUS AND NON-PRECIOUS METALS AND STONES (U.S. CLS. 2, 27, 28 AND 50).

FIRST USE 5-1-2010; IN COMMERCE 9-1-2010.

3,941,634. STRANGE MUSIC, INC., BLUE SPRINGS, MO. SN 77-892,015. PUB. 5-4-2010, FILED 12-11-2009.

# TECH N9NE

THE MARK CONSISTS OF STANDARD CHARACTERS WITHOUT CLAIM TO ANY PARTICULAR FONT, STYLE, SIZE, OR COLOR.

OWNER OF U.S. REG. NO. 3,721,948.

FOR BRACELETS; CHARMS; JEWELRY; JEWELRY CASES; JEWELRY CHAINS; RINGS; WATCHES AND JEWELRY (U.S. CLS. 2, 27, 28 AND 50).

FIRST USE 5-18-2007; IN COMMERCE 5-18-2007.

3,942,096. WATCHLINQ, REDONDO BEACH, CA. SN 85-008,359. PUB. 8-31-2010, FILED 4-7-2010.

# DI BACARRI

THE MARK CONSISTS OF STANDARD CHARACTERS WITHOUT CLAIM TO ANY PARTICULAR FONT, STYLE, SIZE, OR COLOR.

FOR WATCHES (U.S. CLS. 2, 27, 28 AND 50).

FIRST USE 1-31-2009; IN COMMERCE 1-31-2009.

3,941,698. TERESITA PEDRAZA, MIAMI, FL. SN 77-900,797. PUB. 5-18-2010, FILED 12-24-2009.

# GUSANENSIS CUBANUS

THE MARK CONSISTS OF STANDARD CHARACTERS WITHOUT CLAIM TO ANY PARTICULAR FONT, STYLE, SIZE, OR COLOR.

FOR JEWELRY (U.S. CLS. 2, 27, 28 AND 50).  
FIRST USE 1-3-2011; IN COMMERCE 1-3-2011.

3,942,099. M.Z.BERGER & CO., INC., LONG ISLAND CITY, NY. SN 85-010,140. PUB. 7-20-2010, FILED 4-9-2010.

# I-KIDZ

THE MARK CONSISTS OF STANDARD CHARACTERS WITHOUT CLAIM TO ANY PARTICULAR FONT, STYLE, SIZE, OR COLOR.

FOR WATCHES (U.S. CLS. 2, 27, 28 AND 50).

FIRST USE 9-1-2010; IN COMMERCE 9-1-2010.

**CLASS 15—MUSICAL INSTRUMENTS**

**CLASS 15—(Continued).**

3,941,968. PATTERSON, LYNDON, HONOLULU, HI. SN 77-958,247. PUB. 8-10-2010, FILED 3-12-2010.

**A  rd Hand**

THE MARK CONSISTS OF THE WORDING "A RD HAND", WITH A DESIGN OF THE HAND HOLDING UP THREE FINGERS APPEARING BETWEEN "A" AND "RD". FOR MUSICAL INSTRUMENTS (U.S. CLS. 2, 21 AND 36).

FIRST USE 1-1-2011; IN COMMERCE 1-1-2011.

**CLASS 16—PAPER GOODS AND PRINTED MATTER**

3,941,028. WAUSAU PAPER MILLS, LLC, WAUSAU, WI. SN 77-196,925. PUB. 11-20-2007, FILED 6-4-2007.

**EXPERTEC PLATEAU**

THE MARK CONSISTS OF STANDARD CHARACTERS WITHOUT CLAIM TO ANY PARTICULAR FONT, STYLE, SIZE, OR COLOR.

OWNER OF U.S. REG. NO. 3,107,363. FOR PAPERS USED IN THE MANUFACTURE OF RELEASE LINER FOR PRESSURE SENSITIVE ADHESIVE APPLICATIONS (U.S. CLS. 2, 5, 22, 23, 29, 37, 38 AND 50).

FIRST USE 9-0-2007; IN COMMERCE 9-0-2007.

3,941,037. KAPLANIDIS, WILLIAM, BAYSIDE, NY. AND SARMIENTO, REINE, BAYSIDE, NY. SN 77-228,286. PUB. 6-3-2008, FILED 7-12-2007.

**ACUDRAGON**

THE MARK CONSISTS OF STANDARD CHARACTERS WITHOUT CLAIM TO ANY PARTICULAR FONT, STYLE, SIZE, OR COLOR.

FOR PRINTED EDUCATIONAL MATERIALS IN THE AREA OF ACUPUNCTURE AND AROMATHERAPY (U.S. CLS. 2, 5, 22, 23, 29, 37, 38 AND 50).

FIRST USE 1-1-2011; IN COMMERCE 1-1-2011.

**CLASS 16—(Continued).**

3,941,090. PROVO CRAFT AND NOVELTY, INC., SOUTH JORDAN, UT. SN 77-488,397. PUB. 11-24-2009, FILED 6-2-2008.

**TURN ON YOUR CREATIVE BEST**

THE MARK CONSISTS OF STANDARD CHARACTERS WITHOUT CLAIM TO ANY PARTICULAR FONT, STYLE, SIZE, OR COLOR.

FOR MACHINES FOR HOME USE FOR USE IN CRAFTING AND SCRAP BOOKING, NAMELY, DOCUMENT BINDING MACHINES AND LAMINATING MACHINES; A HOUSE MARK FOR A FULL LINE OF STATIONERY, CRAFT PAPER, SUPPLIES AND EQUIPMENT, NAMELY, PAPER EMBOSSERS, ADHESIVE TAPE FOR STATIONERY OR HOUSEHOLD PURPOSES, CRAFT, HOBBY OR HOUSEHOLD USE, SCRAPBOOKS AND PHOTOGRAPH ALBUMS, ALBUM PAGES AND MOUNTS, AND ACCESSORIES FOR USE THEREWITH, NAMELY, CUTTING TEMPLATES AND KNIVES SOLD AS A UNIT, DOCUMENT AND PAPER BINDING MACHINES FOR HOME AND OFFICE USE, BINDING MATERIALS FOR BOOKS AND PAPERS, AND BOOK BINDINGS FOR USE IN CRAFTING, SCRAP BOOKING, AND DECORATIVE ARTS (U.S. CLS. 2, 5, 22, 23, 29, 37, 38 AND 50).

FIRST USE 4-1-2008; IN COMMERCE 4-1-2008.

3,941,140. TRANS WESTERN POLYMERS, INC., LIVERMORE, CA. SN 77-583,295. PUB. 3-17-2009, FILED 10-1-2008.

**HANDY FLAP**

THE MARK CONSISTS OF STANDARD CHARACTERS WITHOUT CLAIM TO ANY PARTICULAR FONT, STYLE, SIZE, OR COLOR.

NO CLAIM IS MADE TO THE EXCLUSIVE RIGHT TO USE "FLAP", APART FROM THE MARK AS SHOWN, FOR TRASH BAGS (U.S. CLS. 2, 5, 22, 23, 29, 37, 38 AND 50).

FIRST USE 12-30-2010; IN COMMERCE 1-5-2011.

**CLASS 16—(Continued).**

3,941,161. PINHO, NATHAN, ROSELLE, NJ. SN 77-611,755.  
PUB. 9-29-2009, FILED 11-11-2008.

**KNOWLEDGE-IN-A-BOTTLE**

THE MARK CONSISTS OF STANDARD CHARACTERS WITHOUT CLAIM TO ANY PARTICULAR FONT, STYLE, SIZE, OR COLOR.

FOR EDUCATIONAL BOOKS FEATURING CONDENSED VERSION IN A BOTTLE FEATURING MATHEMATICS, MUSIC, GRAMMAR (U.S. CLS. 2, 5, 22, 23, 29, 37, 38 AND 50).

FIRST USE 6-22-2010; IN COMMERCE 6-22-2010.

3,941,211. MUDGE, ALFRED GEORGE, WASSAIC, NY. SN 77-661,473. PUB. 10-27-2009, FILED 2-2-2009.

**USE THE VISUAL TO STIMULATE THE VERBAL**

THE MARK CONSISTS OF STANDARD CHARACTERS WITHOUT CLAIM TO ANY PARTICULAR FONT, STYLE, SIZE, OR COLOR.

FOR PRINTED EDUCATIONAL MATERIALS FOR LANGUAGE AND VOCATIONAL TRAINING (U.S. CLS. 2, 5, 22, 23, 29, 37, 38 AND 50).

FIRST USE 9-22-2009; IN COMMERCE 9-22-2009.

3,941,213. MUDGE, ALFRED GEORGE, WASSAIC, NY. SN 77-661,485. PUB. 10-27-2009, FILED 2-2-2009.

**UVSV**

THE MARK CONSISTS OF STANDARD CHARACTERS WITHOUT CLAIM TO ANY PARTICULAR FONT, STYLE, SIZE, OR COLOR.

FOR PRINTED EDUCATIONAL MATERIALS FOR LANGUAGE AND VOCATIONAL TRAINING (U.S. CLS. 2, 5, 22, 23, 29, 37, 38 AND 50).

FIRST USE 9-22-2009; IN COMMERCE 9-22-2009.

**CLASS 16—(Continued).**

3,941,215. ONCE OPENED, LLC, COXSACKIE, NY. SN 77-664,967. PUB. 6-2-2009, FILED 2-6-2009.



THE MARK CONSISTS OF AN IMAGE OF A SILOUETTE OF A WOMAN HOLDING A WATCH IN HER HAND INSIDE A OVAL SHAPED DESIGN. TO THE RIGHT OF THE IMAGE IS THE STYLIZED WORDS "ONCE OPENED". OUTSIDE OF THE OVAL IS A CLOUD-LIKE DESIGN.

FOR EXPIRATION LABELING KIT FOR PRODUCTS THAT BEGIN THEIR LIFE SPAN ONCE THEY ARE OPENED - CONSISTS OF, MARKERS, SELF LAMINATED LABELS, GUIDE, AND PENS SOLD AS A UNIT (U.S. CLS. 2, 5, 22, 23, 29, 37, 38 AND 50).

FIRST USE 12-15-2005; IN COMMERCE 2-1-2010.

3,941,230. TENNMAN BRANDS, LLC, NEW YORK, NY. SN 77-679,786. PUB. 12-22-2009, FILED 2-27-2009.

**IT'S ALWAYS 901**

THE MARK CONSISTS OF STANDARD CHARACTERS WITHOUT CLAIM TO ANY PARTICULAR FONT, STYLE, SIZE, OR COLOR.

FOR POSTERS; BLANK CARDS; POSTCARDS; STATIONERY; PAPER; PHOTOGRAPHIC, PICTURE OR ART MOUNTS; PHOTOGRAPHIC PRINTS; COLLAGES; PHOTOGRAPHS; DECORATIVE PAPER CENTERPIECES; COASTERS MADE OF PAPER; MAGAZINES, PAMPHLETS AND BROCHURES IN THE FIELDS OF MUSIC, ENTERTAINMENT AND BEVERAGES (U.S. CLS. 2, 5, 22, 23, 29, 37, 38 AND 50).

FIRST USE 4-0-2009; IN COMMERCE 4-0-2009.

**CLASS 16—(Continued).**

3,941,248. BIG IDEA ENTERTAINMENT, LLC, NEW YORK, NY. SN 77-703,389. PUB. 8-11-2009, FILED 3-31-2009.

**VALUES TO GROW BY**

THE MARK CONSISTS OF STANDARD CHARACTERS WITHOUT CLAIM TO ANY PARTICULAR FONT, STYLE, SIZE, OR COLOR.

FOR EDUCATIONAL BOOKS, NAMELY, A CURRICULUM BASED ON BIBLICAL STORIES (U.S. CLS. 2, 5, 22, 23, 29, 37, 38 AND 50).

FIRST USE 5-1-2009; IN COMMERCE 5-1-2009.

3,941,332. FIBERMARK NORTH AMERICA, INC., BRATTLEBORO, VT. SN 77-769,984. PUB. 6-15-2010, FILED 6-29-2009.

**PELLAQ SNAKESKIN**

THE MARK CONSISTS OF STANDARD CHARACTERS WITHOUT CLAIM TO ANY PARTICULAR FONT, STYLE, SIZE, OR COLOR.

OWNER OF U.S. REG. NO. 3,358,794.

NO CLAIM IS MADE TO THE EXCLUSIVE RIGHT TO USE "SNAKESKIN", APART FROM THE MARK AS SHOWN.

FOR CELLULOSE BLEND PAPER COATED WITH RESINOUS AND PLASTIC LATEX FILM FOR USE AS A COVERING FOR THE PACKAGING AND PUBLISHING INDUSTRIES (U.S. CLS. 2, 5, 22, 23, 29, 37, 38 AND 50).

FIRST USE 8-20-2009; IN COMMERCE 8-20-2009.

3,941,340. SOURCE INTERLINK MAGAZINES, LLC, EL SEGUNDO, CA. SN 77-772,807. PUB. 12-1-2009, FILED 7-1-2009.

**PROJECT CAR**

THE MARK CONSISTS OF STANDARD CHARACTERS WITHOUT CLAIM TO ANY PARTICULAR FONT, STYLE, SIZE, OR COLOR.

NO CLAIM IS MADE TO THE EXCLUSIVE RIGHT TO USE "CAR", APART FROM THE MARK AS SHOWN.

FOR MAGAZINES IN THE FIELD OF EVERYDAY SPORT COMPACT CARS GEARED TOWARDS THE BUDGET-MINDED AUTOMOTIVE ENTHUSIAST (U.S. CLS. 2, 5, 22, 23, 29, 37, 38 AND 50).

FIRST USE 10-0-2006; IN COMMERCE 10-0-2006.

**CLASS 16—(Continued).**

3,941,363. SHMIRSHKY UNIVERSAL, LLC, CORONADO, CA. SN 77-781,070. PUB. 5-25-2010, FILED 7-14-2009.

**SHMIRSHKY**

THE MARK CONSISTS OF STANDARD CHARACTERS WITHOUT CLAIM TO ANY PARTICULAR FONT, STYLE, SIZE, OR COLOR.

FOR PRINTED MATTER, NAMELY, BOOKS IN THE FIELD OF WOMEN'S ISSUES, AND STATIONERY (U.S. CLS. 2, 5, 22, 23, 29, 37, 38 AND 50).

FIRST USE 3-1-2010; IN COMMERCE 3-1-2010.

3,941,406. GORDON, JULLIEN NEWTON, OAKLAND, CA. SN 77-798,453. PUB. 1-26-2010, FILED 8-6-2009.

**GOOD EXCUSE GOALS**

NO CLAIM IS MADE TO THE EXCLUSIVE RIGHT TO USE "GOALS", APART FROM THE MARK AS SHOWN.

THE COLOR(S) RED AND GRAY IS/ARE CLAIMED AS A FEATURE OF THE MARK.

THE MARK CONSISTS OF THE WORDING "GOOD EXCUSE GOALS" IN ALL CAPITAL LETTERS AND IN GRAY, WITH THE LETTER "X" IN RED AND WITH A BOX BEHIND THE "X" OUTLINED IN GRAY.

FOR A SERIES OF BOOKS, WRITTEN ARTICLES, HANDOUTS AND WORKSHEETS IN THE FIELD OF PERSONAL AND PROFESSIONAL DEVELOPMENT (U.S. CLS. 2, 5, 22, 23, 29, 37, 38 AND 50).

FIRST USE 8-1-2009; IN COMMERCE 12-1-2009.

3,941,438. SOCIETE BIC, CLICHY, FRANCE. SN 77-812,010. PUB. 6-29-2010, FILED 8-25-2009.

**CRISTAL LADY**

THE MARK CONSISTS OF STANDARD CHARACTERS WITHOUT CLAIM TO ANY PARTICULAR FONT, STYLE, SIZE, OR COLOR.

THE ENGLISH TRANSLATION OF "CRISTAL" IN THE MARK IS "CRYSTAL".

FOR WRITING INSTRUMENTS, NAMELY, PENS (U.S. CLS. 2, 5, 22, 23, 29, 37, 38 AND 50).

FIRST USE 7-30-2010; IN COMMERCE 7-30-2010.

**CLASS 16—(Continued).**

3,941,445. LP CREATIVE, TWINSBURG, OH. SN 77-816,292. PUB. 6-29-2010, FILED 8-31-2009.

# The Stone Tablet

THE MARK CONSISTS OF STANDARD CHARACTERS WITHOUT CLAIM TO ANY PARTICULAR FONT, STYLE, SIZE, OR COLOR.

NO CLAIM IS MADE TO THE EXCLUSIVE RIGHT TO USE "TABLET", APART FROM THE MARK AS SHOWN. FOR DRY ERASE WRITING BOARDS AND WRITING SURFACES; MARKERS (U.S. CLS. 2, 5, 22, 23, 29, 37, 38 AND 50).

FIRST USE 9-1-2010; IN COMMERCE 9-1-2010.

**CLASS 16—(Continued).**

3,941,503. CABINTIGER STUDIO, INC., DADEVILLE, AL. SN 77-851,928. PUB. 9-14-2010, FILED 10-19-2009.



THE COLOR(S) BLUE, WHITE, BLACK AND ORANGE IS/ ARE CLAIMED AS A FEATURE OF THE MARK.

THE MARK CONSISTS OF THE FOLLOWING: A DIAGONALLY STRIPED RECTANGLE WITH A BLACK TRIANGLE AT THE TOP FOLLOWED IN DESCENDING ORDER BY AN ORANGE STRIPE, A BLACK STRIPE AND AN ORANGE STRIPE, WITH A BLACK TRIANGLE AT THE BOTTOM, THAT IS WITHIN THE WHITE SILHOUETTE OF A HOUSE THAT IS WITHIN A BLUE SQUARE.

FOR NOTE CARDS, POSTERS, AND PERPETUAL GARDENING RECORD BOOKS (U.S. CLS. 2, 5, 22, 23, 29, 37, 38 AND 50).

FIRST USE 12-16-2009; IN COMMERCE 12-16-2009.

3,941,465. SMEAD MANUFACTURING COMPANY, THE, HASTINGS, MN. SN 77-828,611. PUB. 6-15-2010, FILED 9-17-2009.

# SEE FILE

THE MARK CONSISTS OF STANDARD CHARACTERS WITHOUT CLAIM TO ANY PARTICULAR FONT, STYLE, SIZE, OR COLOR.

NO CLAIM IS MADE TO THE EXCLUSIVE RIGHT TO USE "FILE", APART FROM THE MARK AS SHOWN.

FOR FILING AND ORGANIZATIONAL SUPPLIES, NAMELY, FILE FOLDERS, DOCUMENT FILES, POCKET FOLDERS, EXPANDING FILES, HANGING FILES, DOCUMENT FOLDERS IN THE FORM OF WALLETS, ORGANIZER FOR STATIONERY USE (U.S. CLS. 2, 5, 22, 23, 29, 37, 38 AND 50).

FIRST USE 3-0-2010; IN COMMERCE 3-0-2010.

3,941,505. U.S. FOODSERVICE, INC., ROSEMONT, IL. SN 77-852,674. PUB. 3-23-2010, FILED 10-20-2009.



NO CLAIM IS MADE TO THE EXCLUSIVE RIGHT TO USE "THE IN-SERVICE EDUCATIONAL LIBRARY FOR HEALTHCARE", APART FROM THE MARK AS SHOWN.

THE COLOR(S) YELLOW, DARK YELLOW, GOLD, BLACK, GRAY, LIGHT GRAY AND WHITE IS/ARE CLAIMED AS A FEATURE OF THE MARK.

THE MARK CONSISTS OF THE WORD "HORIZON" APPEARS IN WHITE WITH A GRAY DROP-SHADOW AND A LIGHT-GRAY PERSPECTIVE DROP-SHADOW, IN FRONT OF A SUN DESIGN GRADING FROM BOTTOM TO TOP AS FOLLOWS: YELLOW, DARK YELLOW, GOLD. THE PHRASE "THE IN-SERVICE EDUCATIONAL LIBRARY FOR HEALTHCARE" APPEARS IN SMALL BLACK LETTERS OVER THE WORD "HORIZON".

FOR PRINTED EDUCATIONAL MATERIALS IN THE FIELD OF NUTRITION, FOOD SAFETY, AND BEST PRACTICES IN THE FIELD OF FOOD HANDLING AND FOOD PREPARATION (U.S. CLS. 2, 5, 22, 23, 29, 37, 38 AND 50).

FIRST USE 11-23-2010; IN COMMERCE 11-23-2010.

**CLASS 16—(Continued).**

3,941,523. RANDOM HOUSE, INC., NEW YORK, NY. SN 77-858,715. PUB. 2-16-2010, FILED 10-27-2009.

**DOCTOR SPEKTOR**

THE MARK CONSISTS OF STANDARD CHARACTERS WITHOUT CLAIM TO ANY PARTICULAR FONT, STYLE, SIZE, OR COLOR.

FOR COMIC BOOKS, MAGAZINES IN THE FIELD OF ENTERTAINMENT, GRAPHIC NOVELS, POSTERS, POST CARDS, GREETING CARDS AND CALENDARS (U.S. CLS. 2, 5, 22, 23, 29, 37, 38 AND 50).

FIRST USE 2-16-2010; IN COMMERCE 9-22-2010.

---

3,941,539. PROCTER & GAMBLE COMPANY, THE, CINCINNATI, OH. SN 77-865,595. PUB. 4-20-2010, FILED 11-5-2009.

**CLEANS UP HOLDS UP**

THE MARK CONSISTS OF STANDARD CHARACTERS WITHOUT CLAIM TO ANY PARTICULAR FONT, STYLE, SIZE, OR COLOR.

NO CLAIM IS MADE TO THE EXCLUSIVE RIGHT TO USE "CLEANS", APART FROM THE MARK AS SHOWN.

FOR PAPER TOWELS (U.S. CLS. 2, 5, 22, 23, 29, 37, 38 AND 50).

FIRST USE 2-28-2008; IN COMMERCE 2-28-2008.

---

3,941,545. PROCTER & GAMBLE COMPANY, THE, CINCINNATI, OH. SN 77-868,270. PUB. 4-20-2010, FILED 11-9-2009.



NO CLAIM IS MADE TO THE EXCLUSIVE RIGHT TO USE "CLEANS", APART FROM THE MARK AS SHOWN.

THE MARK CONSISTS OF THE WORDS "CLEANS UP" ON TOP OF A BANNER WITH START BURSTS WITH THE WORDS "HOLDS UP" UNDER THE BANNER; THE BANNER ENDS WITH A GRAPHIC STYLIZED DEPICTION OF A PAPER TOWEL.

FOR PAPER TOWELS (U.S. CLS. 2, 5, 22, 23, 29, 37, 38 AND 50).

FIRST USE 4-30-2010; IN COMMERCE 4-30-2010.

**CLASS 16—(Continued).**

3,941,610. UNISOURCE WORLDWIDE, INC., NORCROSS, GA. SN 77-883,501. PUB. 4-6-2010, FILED 12-1-2009.

**ECOLOGICARD**

THE MARK CONSISTS OF STANDARD CHARACTERS WITHOUT CLAIM TO ANY PARTICULAR FONT, STYLE, SIZE, OR COLOR.

FOR PAPER, NAMELY, RECYCLABLE CARD STOCK (U.S. CLS. 2, 5, 22, 23, 29, 37, 38 AND 50).

FIRST USE 9-15-2010; IN COMMERCE 9-15-2010.

---

3,941,611. SMARTHEALTH, INC., PHOENIX, AZ. SN 77-883,563. PUB. 10-12-2010, FILED 12-1-2009.

**SMARTSTART KIT**

THE MARK CONSISTS OF STANDARD CHARACTERS WITHOUT CLAIM TO ANY PARTICULAR FONT, STYLE, SIZE, OR COLOR.

NO CLAIM IS MADE TO THE EXCLUSIVE RIGHT TO USE "KIT", APART FROM THE MARK AS SHOWN.

FOR MEDICAL AND DENTAL PRACTICE PRINTED MARKETING MATERIALS SOLD TO MEDICAL AND DENTAL PROFESSIONALS, NAMELY, BROCHURES AND PATIENT COMMUNICATION MATERIALS, IN THE FIELD OF MEDICAL AND DENTAL ISSUES; DENTAL AND MEDICAL PRACTICE BUILDING KIT CONSISTING PRIMARILY OF PRINTED PATIENT COMMUNICATION PRODUCTS, NAMELY, POSTCARDS, APPOINTMENT CARDS, CATALOGS IN THE FIELD OF MEDICAL AND DENTAL HEALTH ISSUES, SPECIAL OFFER COUPONS, A PRINTED WELCOME LETTER IN THE FIELD OF MEDICAL AND DENTAL HEALTH ISSUES, AND PLASTIC SUPPLY BAGS (U.S. CLS. 2, 5, 22, 23, 29, 37, 38 AND 50).

FIRST USE 1-5-2011; IN COMMERCE 1-5-2011.

---

3,941,612. CREATIVE COMPANY, THE, MANKATO, MN. SN 77-884,067. PUB. 4-27-2010, FILED 12-2-2009.

**AMICUS**

THE MARK CONSISTS OF STANDARD CHARACTERS WITHOUT CLAIM TO ANY PARTICULAR FONT, STYLE, SIZE, OR COLOR.

FOR CHILDREN'S BOOKS (U.S. CLS. 2, 5, 22, 23, 29, 37, 38 AND 50).

FIRST USE 7-30-2010; IN COMMERCE 7-30-2010.

**CLASS 16—(Continued).**

3,941,637. FLYERWHIZ, LLC, ROCKLIN, CA. SN 77-892,899.  
PUB. 11-2-2010, FILED 12-14-2009.

# FLYERWHIZ

THE MARK CONSISTS OF STANDARD CHARACTERS WITHOUT CLAIM TO ANY PARTICULAR FONT, STYLE, SIZE, OR COLOR.

FOR DOCUMENT COVERS, NAMELY, TRANSPARENT PROTECTIVE CASES FOR DISPLAYING REAL ESTATE ADVERTISEMENTS AND OTHER PRINT MATERIALS (U.S. CLS. 2, 5, 22, 23, 29, 37, 38 AND 50).  
FIRST USE 11-19-2010; IN COMMERCE 11-19-2010.

3,941,772. EASY PEASY, LLC, SANTA MONICA, CA. SN 77-914,075. PUB. 6-1-2010, FILED 1-18-2010.

# Easy Peasy

THE MARK CONSISTS OF STANDARD CHARACTERS WITHOUT CLAIM TO ANY PARTICULAR FONT, STYLE, SIZE, OR COLOR.

FOR CHILDREN'S BOOKS (U.S. CLS. 2, 5, 22, 23, 29, 37, 38 AND 50).  
FIRST USE 1-1-2008; IN COMMERCE 6-1-2010.

3,941,913. NEUEDGE, LLC, MAGEE, MS. SN 77-939,954. PUB. 11-23-2010, FILED 2-19-2010.

# NeuEdge

THE COLOR(S) GRAY AND ORANGE IS/ARE CLAIMED AS A FEATURE OF THE MARK.

**CLASS 16—(Continued).**

THE MARK CONSISTS OF THE WORDING "NEUEDGE" WITH THE LETTERS "N" AND THE SECOND "E" APPEARING IN UPPERCASE LETTERS AND THE REMAINING LETTERS IN LOWER-CASE LETTERS. THE LETTERS "NEU" ARE IN GRAY AND THE LETTERS "EDGE" ARE IN ORANGE.

FOR PRINTED MATTER, NAMELY, BOOKS, JOURNALS, MAGAZINES, CHARTS, AND NEWSLETTERS IN THE FIELD OF LEARNING DIFFICULTIES; PRINTED PERIODICALS IN THE FIELD OF LEARNING; PRINTED PERIODICALS IN THE FIELD OF LEARNING DIFFICULTIES; PRINTED INSTRUCTIONAL AND TEACHING MATERIALS IN THE FIELD OF LEARNING; PRINTED VISUALS IN THE NATURE OF EYE EXERCISE CHARTS AND INFORMATIONAL AIDS IN THE FIELD OF LEARNING DIFFICULTIES (U.S. CLS. 2, 5, 22, 23, 29, 37, 38 AND 50).  
FIRST USE 2-7-2011; IN COMMERCE 2-7-2011.

3,941,951. WANBLI WANAGI, LTD., FRIENDSWOOD, TX. SN 77-951,659. PUB. 7-27-2010, FILED 3-5-2010.

# ADVOKT

THE MARK CONSISTS OF STANDARD CHARACTERS WITHOUT CLAIM TO ANY PARTICULAR FONT, STYLE, SIZE, OR COLOR.

FOR THREE DIMENSIONAL MODELS FOR INSTRUCTIONAL AND EDUCATIONAL PURPOSES (U.S. CLS. 2, 5, 22, 23, 29, 37, 38 AND 50).  
FIRST USE 1-11-2011; IN COMMERCE 1-11-2011.

3,941,977. HELP ME SPEAK CARDS, INC., EL CAJON, CA. SN 77-960,489. PUB. 8-3-2010, FILED 3-16-2010.

# HelpMeSpeak

THE MARK CONSISTS OF STANDARD CHARACTERS WITHOUT CLAIM TO ANY PARTICULAR FONT, STYLE, SIZE, OR COLOR.

FOR CARDS, NAMELY, PRINTED COMMUNICATION CARDS (U.S. CLS. 2, 5, 22, 23, 29, 37, 38 AND 50).  
FIRST USE 9-20-2010; IN COMMERCE 9-20-2010.

**CLASS 16—(Continued).**

3,942,038. HAPPY HOUSE, NORTHRIDGE, CA. SN 77-981,369. PUB. 6-1-2010, FILED 1-13-2010.

HAPPY HOUSE GOOD CHOICES

THE MARK CONSISTS OF STANDARD CHARACTERS WITHOUT CLAIM TO ANY PARTICULAR FONT, STYLE, SIZE, OR COLOR.

OWNER OF U.S. REG. NO. 3,615,692.  
FOR PUBLICATIONS, NAMELY, WORKBOOKS, MANUALS, GUIDES, AND ACTIVITY BOOKS IN THE FIELDS OF PARENTING, CHILDREN'S EDUCATION, AND SOCIAL ISSUES THAT FACE CHILDREN AND TEENAGERS (U.S. CLS. 2, 5, 22, 23, 29, 37, 38 AND 50).  
FIRST USE 3-1-2010; IN COMMERCE 3-1-2010.

3,942,042. DAVID C COOK, COLORADO SPRINGS, CO. SN 77-981,414. PUB. 1-5-2010, FILED 8-25-2008.



THE MARK CONSISTS OF THE WORDS "CRAZY LOVE" ACCOMPANIED BY OPPOSITE DIRECTIONAL ARROWS.  
FOR BOOK COVERS; EDUCATIONAL PUBLICATIONS, NAMELY, STORY BOOKS AND EDUCATIONAL BOOKLETS IN THE FIELD OF CHRISTIAN FAITH; RELIGIOUS BOOKS (U.S. CLS. 2, 5, 22, 23, 29, 37, 38 AND 50).  
FIRST USE 3-1-2008; IN COMMERCE 3-1-2008.

**CLASS 16—(Continued).**

3,942,109. OUSLEY N EARLY JR., SAINT PAUL, MN. SN 85-014,948. PUB. 9-14-2010, FILED 4-15-2010.

Hell's Order Of The  
Illuminati

THE MARK CONSISTS OF STANDARD CHARACTERS WITHOUT CLAIM TO ANY PARTICULAR FONT, STYLE, SIZE, OR COLOR.

FOR A SERIES OF BOOKS AND WRITTEN ARTICLES IN THE FIELD OF SELF IMPROVEMENT (U.S. CLS. 2, 5, 22, 23, 29, 37, 38 AND 50).  
FIRST USE 9-14-2010; IN COMMERCE 11-9-2010.

3,942,229. NEW PENDULUM CORP., WILMINGTON, DE. SN 85-056,093. PUB. 11-2-2010, FILED 6-7-2010.

EZ-PICK

THE MARK CONSISTS OF STANDARD CHARACTERS WITHOUT CLAIM TO ANY PARTICULAR FONT, STYLE, SIZE, OR COLOR.

FOR PACKING MATERIALS, NAMELY, CARDBOARD LINERS AND INSERTS FOR INDUSTRIAL SPILL KITS (U.S. CLS. 2, 5, 22, 23, 29, 37, 38 AND 50).  
FIRST USE 12-8-2010; IN COMMERCE 12-8-2010.

3,942,247. PLYMOUTH TRADING COMPANY, LLC, PLYMOUTH, MN. SN 85-064,288. PUB. 11-16-2010, FILED 6-16-2010.

PLYMOUTH PRO

THE MARK CONSISTS OF STANDARD CHARACTERS WITHOUT CLAIM TO ANY PARTICULAR FONT, STYLE, SIZE, OR COLOR.  
FOR TRASH BAGS (U.S. CLS. 2, 5, 22, 23, 29, 37, 38 AND 50).  
FIRST USE 11-10-2010; IN COMMERCE 11-10-2010.



**CLASS 16—(Continued).**

3,942,257. NORTHERN SAFETY CO., INC., FRANKFORT, NY. SN 85-066,314. PUB. 11-16-2010, FILED 6-18-2010.

**N-SWIPES**

THE MARK CONSISTS OF STANDARD CHARACTERS WITHOUT CLAIM TO ANY PARTICULAR FONT, STYLE, SIZE, OR COLOR.

FOR DISPOSABLE WIPES NOT IMPREGNATED WITH CHEMICALS OR COMPOUNDS (U.S. CLS. 2, 5, 22, 23, 29, 37, 38 AND 50).

FIRST USE 8-31-2010; IN COMMERCE 8-31-2010.

---

3,942,280. ELMER'S PRODUCTS, INC., COLUMBUS, OH. SN 85-073,491. PUB. 11-16-2010, FILED 6-29-2010.

**WOBBLE TOPPLE**

THE MARK CONSISTS OF STANDARD CHARACTERS WITHOUT CLAIM TO ANY PARTICULAR FONT, STYLE, SIZE, OR COLOR.

FOR ELECTRIC PENCIL SHARPENERS (U.S. CLS. 2, 5, 22, 23, 29, 37, 38 AND 50).

FIRST USE 12-15-2010; IN COMMERCE 12-15-2010.

**CLASS 17—RUBBER GOODS**

3,941,518. TEKNOR APEX COMPANY, PAWTUCKET, RI. SN 77-857,474. PUB. 8-3-2010, FILED 10-26-2009.

**Family Safe**

THE MARK CONSISTS OF STANDARD CHARACTERS WITHOUT CLAIM TO ANY PARTICULAR FONT, STYLE, SIZE, OR COLOR.

OWNER OF U.S. REG. NOS. 3,692,223 AND 3,692,224.

FOR GARDEN HOSES; WATERING HOSES (U.S. CLS. 1, 5, 12, 13, 35 AND 50).

FIRST USE 12-31-2008; IN COMMERCE 12-31-2008.

**CLASS 17—(Continued).**

3,941,588. KLOCKNER PENTAPLAST GMBH & CO. KG, HELIGENROTH, FED REP GERMANY. SN 77-879,549. PUB. 6-8-2010, FILED 11-24-2009.

**SECONDLIFE**

THE MARK CONSISTS OF STANDARD CHARACTERS WITHOUT CLAIM TO ANY PARTICULAR FONT, STYLE, SIZE, OR COLOR.

PRIORITY CLAIMED UNDER SEC. 44(D) ON FED REP GERMANY APPLICATION NO. 302009032819, FILED 6-3-2009.

FOR PLASTIC MATERIALS IN THE FORM OF SHEETS, RODS AND TUBES; PLASTIC MATERIAL IN EXTRUDED FORM FOR PRODUCTION (U.S. CLS. 1, 5, 12, 13, 35 AND 50).

FIRST USE 7-31-2009; IN COMMERCE 7-31-2009.

---

3,942,161. MADICO, INC., WOBURN, MA. SN 85-040,717. PUB. 8-31-2010, FILED 5-17-2010.

**CleanTouch**

THE MARK CONSISTS OF STANDARD CHARACTERS WITHOUT CLAIM TO ANY PARTICULAR FONT, STYLE, SIZE, OR COLOR.

FOR LAMINATED PLASTIC FILM TREATED WITH ANTIMICROBIAL AGENTS FOR COMMERCIAL AND INDUSTRIAL USE (U.S. CLS. 1, 5, 12, 13, 35 AND 50).

FIRST USE 5-0-2008; IN COMMERCE 5-0-2008.

---

3,942,293. ISA CORPORATION, SALEM, OR. SN 85-079,779. PUB. 12-7-2010, FILED 7-7-2010.

**PINKY'S**

THE MARK CONSISTS OF STANDARD CHARACTERS WITHOUT CLAIM TO ANY PARTICULAR FONT, STYLE, SIZE, OR COLOR.

FOR INSULATING GLOVES; LATEX FOR USE IN THE MANUFACTURE OF GLOVES FOR CLEANING, COSMETIC, CRAFTS, HEALTH CARE OR OTHER GENERAL PURPOSES; LATEX RUBBER FOR USE IN THE MANUFACTURE OF GLOVES FOR CLEANING, COSMETIC, CRAFTS, HEALTH CARE AND GENERAL PURPOSES; NITRILE RUBBER (U.S. CLS. 1, 5, 12, 13, 35 AND 50).

FIRST USE 7-9-2010; IN COMMERCE 11-2-2010.

**CLASS 18—LEATHER GOODS**

3,940,986. ATHLETA, INC., PETALUMA, CA. SN 76-692,906.  
PUB. 3-31-2009, FILED 9-16-2008.

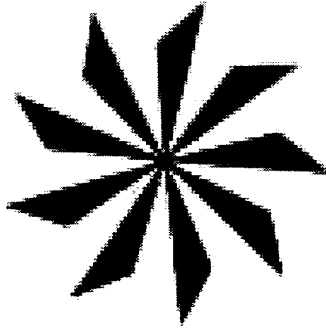

OWNER OF U.S. REG. NO. 3,518,045.  
THE MARK CONSISTS OF A STYLIZED SPIRAL DESIGN.  
FOR HANDBAGS; PURSES; BACKPACKS; BOOK  
BAGS; TOTE BAGS; MESSENGER BAGS; ALL PURPOSE  
SPORT BAGS; BEACH BAGS; DUFFEL BAGS; GENERAL  
PURPOSE BAGS FOR CARRYING YOGA EQUIPMENT  
(U.S. CLS. 1, 2, 3, 22 AND 41).  
FIRST USE 1-1-2010; IN COMMERCE 1-1-2010.

3,941,643. CHE-WEN LIN, TAIPEI COUNTY, TAIWAN. SN  
77-894,271. PUB. 5-18-2010, FILED 12-16-2009.

# Rainman

THE MARK CONSISTS OF STANDARD CHARACTERS  
WITHOUT CLAIM TO ANY PARTICULAR FONT, STYLE,  
SIZE, OR COLOR.

FOR ALL PURPOSE SPORT BAGS; ALL-PURPOSE  
ATHLETIC BAGS; ALL-PURPOSE CARRYING BAGS;  
AMENITY BAGS SOLD EMPTY; ATHLETIC BAGS;  
BACKPACKS, BOOK BAGS, SPORTS BAGS, BUM BAGS,  
WALLETS AND HANDBAGS; BAGS FOR SPORTS; BAGS  
FOR UMBRELLAS; BARREL BAGS; BEACH BAGS;  
BELT BAGS; BOOK BAGS; BOSTON BAGS; CANVAS  
SHOPPING BAGS; CARRY-ALL BAGS; COSMETIC BAGS  
SOLD EMPTY; DRAWSTRING BAGS; DUFFEL BAGS;  
DUFFEL BAGS FOR TRAVEL; DUFFLE BAGS; FLEX-  
IBLE BAGS FOR GARMENTS; FLIGHT BAGS; GAR-  
MENT BAGS FOR TRAVEL; GARMEN BAGS FOR  
TRAVEL MADE OF LEATHER; GENERAL PURPOSE  
BAGS FOR CARRYING YOGA EQUIPMENT; GENERAL  
PURPOSE BAGS FOR HOLDING DANCE EQUIPMENT;  
GENERAL PURPOSE SPORT TROLLEY BAGS; GYM  
BAGS; HIKING BAGS; HOBO BAGS; IMITATION  
LEATHER KEY CHAINS; KEY BAGS; KEY CASES OF  
LEATHER OR IMITATION LEATHER; KIT BAGS;

**CLASS 18—(Continued).**

LEATHER AND IMITATION LEATHER BAGS;  
LEATHER AND IMITATION LEATHER SPORT BAGS  
AND GENERAL PURPOSE TROLLEY BAGS; LEATHER  
BAGS AND WALLETS; LEATHER BAGS FOR MER-  
CHANDISE PACKAGING; LEATHER BAGS, SUITCASES  
AND WALLETS; MAKE-UP BAGS SOLD EMPTY; MES-  
SENGER BAGS; MILITARY DUFFLE BAGS, GARMEN  
BAGS FOR TRAVEL, TOTE BAGS, SHOULDER BAGS  
AND BACKPACKS; PET ACCESSORIES, NAMELY,  
CANVAS, VINYL AND LEATHER POUCHES FOR  
HOLDING DISPOSABLE BAGS TO PLACE PET WASTE  
IN; POUCHES AND BAGS SOLD EMPTY FOR ATTACH-  
MENT TO BACKPACKS; SCHOOL BAGS; SCHOOL  
BOOK BAGS; SHOE BAGS FOR TRAVEL; SHOULDER  
BAGS; SOUVENIR BAGS; SPORT BAGS; SPORTS BAGS;  
SUIT BAGS; TEXTILE SHOPPING BAGS; TOILETRY  
BAGS SOLD EMPTY; TOOL BAGS SOLD EMPTY; TOTE  
BAGS; TRAVEL BAGS; TRAVELING BAGS; WAIST  
BAGS; WHEELED BAGS; WHEELED DUFFLE BAGS;  
WHEELED MESSENGER BAGS (U.S. CLS. 1, 2, 3, 22 AND  
41).

FIRST USE 4-29-2010; IN COMMERCE 4-29-2010.

3,941,729. INFANTINO, LLC, SAN DIEGO, CA. SN 77-907,383.  
PUB. 6-1-2010, FILED 1-7-2010.

# SWIFT

THE MARK CONSISTS OF STANDARD CHARACTERS  
WITHOUT CLAIM TO ANY PARTICULAR FONT, STYLE,  
SIZE, OR COLOR.

FOR INFANT CARRIERS WORN ON THE BODY (U.S.  
CLS. 1, 2, 3, 22 AND 41).  
FIRST USE 6-10-2010; IN COMMERCE 6-10-2010.

3,941,805. ARCHWAY INC., BARRIGADA, GUAM. SN 77-  
919,146. PUB. 6-15-2010, FILED 1-25-2010.

# I ♥ HAWAII

OWNER OF U.S. REG. NOS. 3,613,811 AND 3,747,662.  
NO CLAIM IS MADE TO THE EXCLUSIVE RIGHT TO  
USE "HAWAII", APART FROM THE MARK AS SHOWN.

THE MARK CONSISTS OF THE LETTER "I" TO THE  
LEFT OF A HEART SHAPE WITH THE WORD "HAWAII"  
UNDERNEATH.

FOR TOTE BAGS (U.S. CLS. 1, 2, 3, 22 AND 41).  
FIRST USE 1-3-2011; IN COMMERCE 1-3-2011.

**CLASS 18—(Continued).**

3,941,875. LEATHEN S. STEARN, FT. LAUDERDALE, FL. SN 77-930,507. PUB. 6-22-2010, FILED 2-8-2010.



OWNER OF U.S. REG. NOS. 1,612,163, 3,124,161, AND OTHERS.

THE MARK CONSISTS OF THE COINED TERM "SCUNCI" IN STYLIZED FONT WITH AN UMLAUT OVER THE LETTER "U."

FOR COSMETIC BAGS SOLD EMPTY; COSMETIC CASES SOLD EMPTY; COSMETIC ORGANIZERS SOLD EMPTY; VANITY CASES SOLD EMPTY; TOILETRY CASES SOLD EMPTY; TOTE BAGS (U.S. CLS. 1, 2, 3, 22 AND 41).

FIRST USE 3-20-2009; IN COMMERCE 3-20-2009.

3,941,958. KRIS LOGAN, CLEARWATER, FL. SN 77-954,008. PUB. 8-3-2010, FILED 3-9-2010.

**IN DOG WE TRUST**

THE MARK CONSISTS OF STANDARD CHARACTERS WITHOUT CLAIM TO ANY PARTICULAR FONT, STYLE, SIZE, OR COLOR.

FOR CLOTHING FOR DOGS, NAMELY, SHIRTS, SHORTS, HATS, AND BANDANAS (U.S. CLS. 1, 2, 3, 22 AND 41).

FIRST USE 12-18-2010; IN COMMERCE 12-18-2010.

3,942,086. BARTH & MCCALLIG, LLC, JUPITER, FL. SN 85-004,648. PUB. 8-24-2010, FILED 4-1-2010.

**BARTH & MCCALLIG**

THE MARK CONSISTS OF STANDARD CHARACTERS WITHOUT CLAIM TO ANY PARTICULAR FONT, STYLE, SIZE, OR COLOR.

FOR UMBRELLAS, SHOE BAGS FOR TRAVEL (U.S. CLS. 1, 2, 3, 22 AND 41).

FIRST USE 1-28-2010; IN COMMERCE 1-28-2010.

**CLASS 19—NON-METALLIC BUILDING MATERIALS****CLASS 19—(Continued).**

3,941,208. CERAMICA ALBERDI SA, SANTA FE, ARGENTINA. SN 77-661,102. PUB. 6-8-2010, FILED 2-2-2009.



NO CLAIM IS MADE TO THE EXCLUSIVE RIGHT TO USE "CERAMICA", APART FROM THE MARK AS SHOWN.

THE MARK CONSISTS OF THE TERM "CERAMICA" IN A STYLIZED FONT ABOVE A DESIGN OF FOUR SQUARE SHAPES, TO THE RIGHT OF THE SQUARE SHAPES IS THE TERM "ALLPA" IN A STYLIZED FONT UNDERNEATH WHICH IS A HORIZONTAL LINE.

THE ENGLISH TRANSLATION OF THE WORD "CERAMICA" IN THE MARK IS CERAMICS. THE WORDING "ALLPA" HAS NO MEANING IN A FOREIGN LANGUAGE.

FOR NON-METALLIC BUILDING MATERIALS, NAMELY, TILES AND CERAMIC TILES AND BRICKS, ENAMELED CERAMICS IN THE NATURE OF TILES, CERAMIC STEPS, CERAMIC TERMINATION IN THE NATURE OF CLADDING AND TRIM, CERAMIC GUARDS FOR FLOORS AND WALLS (U.S. CLS. 1, 12, 33 AND 50).

FIRST USE 1-1-2009; IN COMMERCE 4-6-2009.

3,941,257. MARCON, INC., MERIDIAN, ID. SN 77-721,113. PUB. 6-1-2010, FILED 4-23-2009.

**MC**

THE MARK CONSISTS OF STANDARD CHARACTERS WITHOUT CLAIM TO ANY PARTICULAR FONT, STYLE, SIZE, OR COLOR.

FOR OUTDOOR WORKS OF ART OF CONCRETE; BUILDING STONES, WALL STONES, PAVING STONES FOR GARDENING AND/OR ORNAMENTAL USE; KITCHEN OR BATHROOM HOUSEHOLD FIXTURES MADE OF PRE-CAST OR CAST IN PLACE CONCRETE, NAMELY, COUNTERTOPS AND FIREPLACE MANTELS; PORTABLE CONCRETE FREE STANDING SAFETY BARRIERS; PORTABLE CONCRETE TRAFFIC SAFETY BARRIERS; CRASH BARRIERS OF CONCRETE FOR ROADS (U.S. CLS. 1, 12, 33 AND 50).

FIRST USE 9-29-2006; IN COMMERCE 9-29-2006.

**CLASS 19—(Continued).**

3,941,309. AFFILIATED RESOURCES, INC., PORTLAND, OR. SN 77-762,375. PUB. 5-18-2010, FILED 6-17-2009.

# MAX Tek

THE MARK CONSISTS OF STANDARD CHARACTERS WITHOUT CLAIM TO ANY PARTICULAR FONT, STYLE, SIZE, OR COLOR.

FOR WOOD FLOOR PANELS, NAMELY, ORIENTED STRAND BOARD PANELS; WOOD CEILING PANELS, NAMELY, ORIENTED STRAND BOARD PANELS; WOOD WALL PANELS, NAMELY, ORIENTED STRAND BOARD PANELS; ORIENTED STRAND BOARD WALL PANELS FOR USE IN STRUCTURAL INSULATED PANEL CONSTRUCTION; ORIENTED STRAND BOARD FLOOR PANELS FOR USE IN STRUCTURAL INSULATED PANEL CONSTRUCTION; ORIENTED STRAND BOARD CEILING PANELS FOR USE IN STRUCTURAL INSULATED PANEL CONSTRUCTION (U.S. CLS. 1, 12, 33 AND 50).

FIRST USE 7-22-2009; IN COMMERCE 7-22-2009.

3,941,331. M.G. STONE TRADE, INC., MIAMI BEACH, FL. SN 77-769,498. PUB. 11-17-2009, FILED 6-26-2009.



THE MARK CONSISTS OF THE STYLIZED TEXT "D DESIGN DISTRICT".

FOR NON-METAL BUILDING MATERIALS, NAMELY, STONE, MARBLE, TILE, CERAMIC TILE AND WOOD (U.S. CLS. 1, 12, 33 AND 50).

FIRST USE 9-29-2009; IN COMMERCE 9-29-2009.

3,941,559. MOHAWK CARPET DISTRIBUTION, INC., CALHOUN, GA. SN 77-872,161. PUB. 4-20-2010, FILED 11-13-2009.

# GENUEDGE

THE MARK CONSISTS OF STANDARD CHARACTERS WITHOUT CLAIM TO ANY PARTICULAR FONT, STYLE, SIZE, OR COLOR.

FOR LAMINATE FLOORING (U.S. CLS. 1, 12, 33 AND 50).

FIRST USE 1-15-2010; IN COMMERCE 1-15-2010.

**CLASS 19—(Continued).**

3,941,620. EMPIRE FOAM, LLC, WINTER GARDEN, FL. SN 77-887,666. PUB. 5-4-2010, FILED 12-7-2009.

# LTD SYSTEM

THE MARK CONSISTS OF STANDARD CHARACTERS WITHOUT CLAIM TO ANY PARTICULAR FONT, STYLE, SIZE, OR COLOR.

NO CLAIM IS MADE TO THE EXCLUSIVE RIGHT TO USE "SYSTEM", APART FROM THE MARK AS SHOWN.

FOR NON-METAL DECORATIVE MOLDINGS AND DECORATIVE TRIM FOR USE IN BUILDING CONSTRUCTION (U.S. CLS. 1, 12, 33 AND 50).

FIRST USE 12-1-2010; IN COMMERCE 12-1-2010.

3,941,843. KLIPPERT, JOEL, PUYALLUP, CA. SN 77-925,478. PUB. 6-15-2010, FILED 2-2-2010.

# RECYCLETOP

THE MARK CONSISTS OF STANDARD CHARACTERS WITHOUT CLAIM TO ANY PARTICULAR FONT, STYLE, SIZE, OR COLOR.

FOR BUILDING MATERIALS, NAMELY, COMPOSITE PANELS COMPOSED PRIMARILY OF NONMETAL MATERIALS (U.S. CLS. 1, 12, 33 AND 50).

FIRST USE 4-1-2009; IN COMMERCE 4-1-2009.

3,942,134. JEFF SMITH, ALPHARETTA, GA. SN 85-026,030. PUB. 9-28-2010, FILED 4-29-2010.

# StealthFlow

THE MARK CONSISTS OF THE WORDS "STEALTH" WITH A CAPITAL "S" AND "FLOW" WITH A CAPITAL "F". THE WORD "FLOW" HAS THREE WAVE LINES THROUGH THE WORD.

FOR NON-METAL GUTTER PIPES (U.S. CLS. 1, 12, 33 AND 50).

FIRST USE 8-2-2010; IN COMMERCE 8-17-2010.

**CLASS 19—(Continued).**

3,942,316. JEFFREY COURT, INC., ANAHEIM HILLS, CA. SN 85-096,748. PUB. 10-26-2010, FILED 7-30-2010.

# Streamstone

THE MARK CONSISTS OF STANDARD CHARACTERS WITHOUT CLAIM TO ANY PARTICULAR FONT, STYLE, SIZE, OR COLOR.

FOR BUILDING MATERIALS, NAMELY, STONE TILES (U.S. CLS. 1, 12, 33 AND 50).  
FIRST USE 0-0-2010; IN COMMERCE 0-0-2010.

**CLASS 20—FURNITURE AND ARTICLES NOT OTHERWISE CLASSIFIED**

3,941,113. LOUISVILLE LADDER INC., LOUISVILLE, KY. SN 77-528,712. PUB. 12-2-2008, FILED 7-22-2008.

# PRO GRIP

THE MARK CONSISTS OF STANDARD CHARACTERS WITHOUT CLAIM TO ANY PARTICULAR FONT, STYLE, SIZE, OR COLOR.

NO CLAIM IS MADE TO THE EXCLUSIVE RIGHT TO USE "GRIP", APART FROM THE MARK AS SHOWN.

FOR NON-METAL LADDER ACCESSORIES, NAMELY, A PLASTIC HANDLE WITH NON-SKID SURFACE, FOR USE ON AND ATTACHMENT TO LADDERS (U.S. CLS. 2, 13, 22, 25, 32 AND 50).  
FIRST USE 1-0-2011; IN COMMERCE 1-0-2011.

3,941,370. TWELVE SOUTH, LLC, MOUNT PLEASANT, SC. SN 77-784,132. PUB. 12-7-2010, FILED 7-17-2009.

# BACKPACK

THE MARK CONSISTS OF STANDARD CHARACTERS WITHOUT CLAIM TO ANY PARTICULAR FONT, STYLE, SIZE, OR COLOR.

FOR COMPUTER ACCESSORIES, NAMELY, SHELVES THAT ATTACH BEHIND A COMPUTER MONITOR (U.S. CLS. 2, 13, 22, 25, 32 AND 50).  
FIRST USE 8-31-2009; IN COMMERCE 8-31-2009.

**CLASS 20—(Continued).**

3,941,402. WHOLE SPACE INDUSTRIES LTD., TAIPEI, TAIWAN. SN 77-796,745. PUB. 6-22-2010, FILED 8-4-2009.



NO CLAIM IS MADE TO THE EXCLUSIVE RIGHT TO USE "HOME" AND "CHILD SAFE & ENVIRONMENTALLY RESPONSIBLE PRODUCTS FOR YOUR HOME", APART FROM THE MARK AS SHOWN.

THE MARK CONSISTS OF THE WORDS "HOME BASICS" IN A RECTANGLE AND A RECTANGULAR BLACK BACKGROUND BEHIND THE WORD "BASICS" WITH THE WORDS "CHILD SAFE & ENVIRONMENTALLY RESPONSIBLE PRODUCTS FOR YOUR HOME" BELOW THE RECTANGLE.

FOR WOVEN WOOD WINDOW SHADES, ROLL-UP WINDOW SHADES, ROMAN WINDOW SHADES, VENETIAN BLINDS (U.S. CLS. 2, 13, 22, 25, 32 AND 50).  
FIRST USE 9-1-2010; IN COMMERCE 9-1-2010.

3,941,454. BUCKLEY, CHARISE M., FRISCO, CO. SN 77-821,953. PUB. 8-3-2010, FILED 9-8-2009.



# Beetlekill Blues

NO CLAIM IS MADE TO THE EXCLUSIVE RIGHT TO USE "BEETLEKILL", APART FROM THE MARK AS SHOWN.

THE MARK CONSISTS OF A DESIGN OF THE LETTERS "BKB" WITH THE LAST "B" BACKWARDS, AND THE WORDING "BEETLEKILL BLUES" BELOW THE DESIGN.

FOR FURNITURE (U.S. CLS. 2, 13, 22, 25, 32 AND 50).  
FIRST USE 4-30-2010; IN COMMERCE 4-30-2010.

3,941,456. JEANINE HAYS, SAN FRANCISCO, CA. SN 77-824,194. PUB. 5-11-2010, FILED 9-10-2009.



NO CLAIM IS MADE TO THE EXCLUSIVE RIGHT TO USE "CHIC" AND "STYLE", APART FROM THE MARK AS SHOWN.

**CLASS 20—(Continued).**

THE MARK CONSISTS OF A SILHOUETTE OF A WOMAN'S BUST, WHERE THE WOMAN IS FACING TO THE VIEWER'S LEFT; THE WORD "APHRO" IS ON THE LEFT OF THE SILHOUETTE; THE WORD "CHIC" IS ON THE RIGHT OF THE SILHOUETTE; UNDERNEATH THOSE WORDS AND THE SILHOUETTE, THE PHRASE "MODERN SOULFUL STYLE" WITH PERIODS AFTER EACH OF THE WORDS "MODERN" AND "SOULFUL".

FOR PILLOWS (U.S. CLS. 2, 13, 22, 25, 32 AND 50).  
FIRST USE 6-1-2009; IN COMMERCE 10-1-2009.

---

3,941,606. D-LITE LLC, LEMONT, IL. SN 77-883,018. PUB. 4-27-2010, FILED 12-1-2009.

**WRAP-D-LITE**

THE MARK CONSISTS OF STANDARD CHARACTERS WITHOUT CLAIM TO ANY PARTICULAR FONT, STYLE, SIZE, OR COLOR.

FOR NON-METAL STORAGE REELS FOR ELECTRICAL LIGHTS (U.S. CLS. 2, 13, 22, 25, 32 AND 50).  
FIRST USE 1-1-2010; IN COMMERCE 4-1-2010.

---

3,941,691. ADVANCED NUTRIENTS LTD., ABBOTSFORD, BC, CANADA. SN 77-899,610. PUB. 11-16-2010, FILED 12-22-2009.

**QUICKCURE**

THE MARK CONSISTS OF STANDARD CHARACTERS WITHOUT CLAIM TO ANY PARTICULAR FONT, STYLE, SIZE, OR COLOR.

PRIORITY CLAIMED UNDER SEC. 44(D) ON CANADA APPLICATION NO. 1461459, FILED 12-3-2009, REG. NO. TMA775759, DATED 8-27-2010, EXPIRES 8-27-2015.

FOR METAL RACKS FOR THE DRYING OF PLANTS AND FLOWERS (U.S. CLS. 2, 13, 22, 25, 32 AND 50).  
FIRST USE 12-0-2009; IN COMMERCE 12-0-2009.

**CLASS 20—(Continued).**

3,941,838. POLYFAB MEDICAL, LLC, WOODBRIDGE, VA. SN 77-924,212. PUB. 6-15-2010, FILED 1-30-2010.

**GRYPHES**

THE MARK CONSISTS OF STANDARD CHARACTERS WITHOUT CLAIM TO ANY PARTICULAR FONT, STYLE, SIZE, OR COLOR.

FOR NONMETAL CONTAINERS FOR THE TRANSPORT AND STORAGE OF ORGANS, TISSUES AND CELLS FOR MEDICAL AND SCIENTIFIC PURPOSES (U.S. CLS. 2, 13, 22, 25, 32 AND 50).  
FIRST USE 9-9-2010; IN COMMERCE 10-6-2010.

---

3,941,877. GRIMCO, INC., FENTON, MO. SN 77-930,795. PUB. 5-25-2010, FILED 2-8-2010.



NO CLAIM IS MADE TO THE EXCLUSIVE RIGHT TO USE "BANNER", APART FROM THE MARK AS SHOWN.

THE COLOR(S) BLUE AND BLACK IS/ARE CLAIMED AS A FEATURE OF THE MARK.

THE MARK CONSISTS OF THE WORD "PINNACLE" IN BLUE, CAPITAL LETTERS ABOVE THE WORD "BANNER" IN BLACK, CAPITAL LETTERS. TO THE LEFT OF THE WORDS ARE SEVERAL BLACK ARCS IN VARIOUS SIZES.

FOR BANNER MATERIAL MADE OF PVC VINYL AND POLYESTER (U.S. CLS. 2, 13, 22, 25, 32 AND 50).  
FIRST USE 4-1-2010; IN COMMERCE 4-1-2010.

---

3,941,890. KILBANE, MARGARET M., DETROIT LAKES, MN. SN 77-932,484. PUB. 6-22-2010, FILED 2-10-2010.

**LAKEGIRL**

THE MARK CONSISTS OF STANDARD CHARACTERS WITHOUT CLAIM TO ANY PARTICULAR FONT, STYLE, SIZE, OR COLOR.

OWNER OF U.S. REG. NOS. 3,062,427, 3,411,417, AND 3,494,644.

FOR PICTURE FRAMES, PILLOWS (U.S. CLS. 2, 13, 22, 25, 32 AND 50).  
FIRST USE 10-14-2010; IN COMMERCE 10-14-2010.

**CLASS 20—(Continued).**

3,942,085. AMERICAN SEATING COMPANY, GRAND RAPIDS, MI. SN 85-004,379. PUB. 6-29-2010, FILED 4-1-2010.

# CUE

THE MARK CONSISTS OF STANDARD CHARACTERS WITHOUT CLAIM TO ANY PARTICULAR FONT, STYLE, SIZE, OR COLOR.

OWNER OF U.S. REG. NO. 3,137,166.  
FOR CHAIRS (U.S. CLS. 2, 13, 22, 25, 32 AND 50).  
FIRST USE 6-1-2010; IN COMMERCE 6-1-2010.

---

3,942,103. HNI TECHNOLOGIES INC., MUSCATINE, IA. SN 85-012,473. PUB. 9-7-2010, FILED 4-13-2010.

# CERES

THE MARK CONSISTS OF STANDARD CHARACTERS WITHOUT CLAIM TO ANY PARTICULAR FONT, STYLE, SIZE, OR COLOR.

FOR FURNITURE (U.S. CLS. 2, 13, 22, 25, 32 AND 50).  
FIRST USE 12-30-2010; IN COMMERCE 12-30-2010.

---

3,942,163. NEW DESIGNS FOR COMFORT, INC., NEEDHAM, MA. SN 85-041,440. PUB. 10-19-2010, FILED 5-18-2010.

# A HUMAN IDEA

THE MARK CONSISTS OF STANDARD CHARACTERS WITHOUT CLAIM TO ANY PARTICULAR FONT, STYLE, SIZE, OR COLOR.

FOR CHAIRS (U.S. CLS. 2, 13, 22, 25, 32 AND 50).  
FIRST USE 3-1-2009; IN COMMERCE 3-1-2009.

**CLASS 20—(Continued).**

3,942,164. NEW DESIGNS FOR COMFORT, INC., NEEDHAM, MA. SN 85-041,459. PUB. 10-19-2010, FILED 5-18-2010.

# HUMAN INSTRUMENTS

THE MARK CONSISTS OF STANDARD CHARACTERS WITHOUT CLAIM TO ANY PARTICULAR FONT, STYLE, SIZE, OR COLOR.

FOR CHAIRS (U.S. CLS. 2, 13, 22, 25, 32 AND 50).  
FIRST USE 3-1-2009; IN COMMERCE 3-1-2009.

---

3,942,281. HERMAN MILLER, INC., ZEELAND, MI. SN 85-073,561. PUB. 11-30-2010, FILED 6-29-2010.

# SAYL

THE MARK CONSISTS OF STANDARD CHARACTERS WITHOUT CLAIM TO ANY PARTICULAR FONT, STYLE, SIZE, OR COLOR.

FOR OFFICE FURNITURE, NAMELY, CHAIRS (U.S. CLS. 2, 13, 22, 25, 32 AND 50).  
FIRST USE 10-25-2010; IN COMMERCE 1-10-2011.

---

3,942,303. SAFE-T-SHADE, INC., BURLINGTON, NC. SN 85-083,017. PUB. 12-14-2010, FILED 7-13-2010.

# SAFE-T-WAND

THE MARK CONSISTS OF STANDARD CHARACTERS WITHOUT CLAIM TO ANY PARTICULAR FONT, STYLE, SIZE, OR COLOR.

FOR WINDOW SHADES (U.S. CLS. 2, 13, 22, 25, 32 AND 50).  
FIRST USE 12-14-2010; IN COMMERCE 12-14-2010.

**CLASS 21—HOUSEWARES AND GLASS**

**CLASS 21—(Continued).**

3,941,187. LESLI S. OTT, NEW HAVEN, CT. SN 77-642,433.  
PUB. 4-28-2009, FILED 1-1-2009.

## Fresh Living Inside Four Walls

THE MARK CONSISTS OF STANDARD CHARACTERS WITHOUT CLAIM TO ANY PARTICULAR FONT, STYLE, SIZE, OR COLOR.

FOR PLANTERS FOR FLOWERS AND PLANTS (U.S. CLS. 2, 13, 23, 29, 30, 33, 40 AND 50).

FIRST USE 11-20-2010; IN COMMERCE 11-20-2010.

3,941,249. OUT OF THE BLUE ENTERPRISES LLC, NEW YORK, NY. SN 77-709,689. PUB. 8-4-2009, FILED 4-8-2009.

## SUPER WHY

THE MARK CONSISTS OF STANDARD CHARACTERS WITHOUT CLAIM TO ANY PARTICULAR FONT, STYLE, SIZE, OR COLOR.

FOR PLATES, BOWLS, CUPS, BOTTLES SOLD EMPTY (U.S. CLS. 2, 13, 23, 29, 30, 33, 40 AND 50).

FIRST USE 9-0-2009; IN COMMERCE 9-0-2009.

3,941,268. COGNITIVE SCIENCE LLC, ITHACA, NY. SN 77-732,330. PUB. 11-17-2009, FILED 5-8-2009.

## THINWARE

THE MARK CONSISTS OF STANDARD CHARACTERS WITHOUT CLAIM TO ANY PARTICULAR FONT, STYLE, SIZE, OR COLOR.

FOR BAKEWARE; BEVERAGE GLASSWARE; BEVERAGE WARE, NAMELY, MUGS, COFFEE CUPS, TEA CUPS, INSULATED BEVERAGE CONTAINERS FOR DOMESTIC USE, WATER BOTTLES SOLD EMPTY; COOKWARE, NAMELY, PANS, FRYING PANS, SAUCE PANS, NON-ELECTRIC GRIDDLES, POTS; DINNERWARE; GLASS BOWLS AND DISHES; ICE CREAM SCOOPS; KITCHEN TOOLS AND UTENSILS, NAMELY, SPATULAS, STRAINERS, SIEVES, WHISKS, CUTTING BOARDS, CONTAINERS FOR FOOD DISPENSING, CONTAINERS FOR FOOD STORAGE; NAPKIN RINGS; SALAD BOWLS NOT OF PRECIOUS METAL; SERVICE UTENSILS, NAMELY, SERVING SPOONS, SERVING LADLES, SERVING FORKS, SERVING TONGS; SERVING VESSELS, NAMELY, SERVING BOWLS, SERVING DISHES, SERVING PLATTERS, GRAVY BOATS, BUTTER DISHES; SPOON RESTS; TRIVETS (U.S. CLS. 2, 13, 23, 29, 30, 33, 40 AND 50).

FIRST USE 5-13-2009; IN COMMERCE 5-13-2009.

**CLASS 21—(Continued).**

3,941,392. JAMES CHEN, ROWLAND HEIGHTS, CA. SN 77-793,728. PUB. 12-22-2009, FILED 7-30-2009.

## Cleansation

THE MARK CONSISTS OF STANDARD CHARACTERS WITHOUT CLAIM TO ANY PARTICULAR FONT, STYLE, SIZE, OR COLOR.

FOR BATH BRUSHES; BATH PRODUCTS, NAMELY, BODY SPONGES; BATH PRODUCTS, NAMELY, LOOFAH SPONGES; BATH PRODUCTS, NAMELY, NATURAL SEA SPONGES; BATH SPONGES; SPONGE MASSAGERS; SPONGES FOR HOUSEHOLD PURPOSES (U.S. CLS. 2, 13, 23, 29, 30, 33, 40 AND 50).

FIRST USE 1-1-2011; IN COMMERCE 1-1-2011.

3,941,468. BRITA LP, NEUCHATEL, SWITZERLAND. SN 77-830,002. PUB. 7-13-2010, FILED 9-18-2009.



OWNER OF U.S. REG. NOS. 2,692,101, 2,916,481, AND OTHERS.

THE COLOR(S) BLUE AND LIGHT BLUE IS/ARE CLAIMED AS A FEATURE OF THE MARK.

THE MARK CONSISTS OF BLUE AND LIGHT BLUE DOTS FORMING A FIVE BY FIVE SQUARE WHICH IS NEXT TO THE WORD "BRITA" WHICH APPEARS IN BLUE.

FOR WATER DISPENSERS, NAMELY, PORTABLE WATER DISPENSERS WITH FILTRATION UNITS; PITCHERS (U.S. CLS. 2, 13, 23, 29, 30, 33, 40 AND 50).

FIRST USE 10-7-1980; IN COMMERCE 10-7-1980.

3,941,574. BARNETT, VALERIE D., NEW ROCHELLE, NY. SN 77-876,560. PUB. 5-18-2010, FILED 11-19-2009.

## FRUITSOCK VEGGIESOCK

THE MARK CONSISTS OF STANDARD CHARACTERS WITHOUT CLAIM TO ANY PARTICULAR FONT, STYLE, SIZE, OR COLOR.

FOR HOUSEHOLD CONTAINERS FOR FOODS (U.S. CLS. 2, 13, 23, 29, 30, 33, 40 AND 50).

FIRST USE 9-13-2010; IN COMMERCE 9-13-2010.



**CLASS 21—(Continued).**

3,941,666. REMEMBER2REMEMBER, INC., MARIETTA, GA.  
SN 77-897,709. PUB. 5-11-2010, FILED 12-20-2009.

**CLASS 21—(Continued).**

3,941,669. REMEMBER2REMEMBER, INC., MARIETTA, GA.  
SN 77-897,714. PUB. 5-11-2010, FILED 12-20-2009.

# IT IS FINISHED

# JUSTICE AND MERCY

THE MARK CONSISTS OF STANDARD CHARACTERS WITHOUT CLAIM TO ANY PARTICULAR FONT, STYLE, SIZE, OR COLOR.  
FOR GLASS PRISMS FOR USE AS MNEMONIC DEVICES (U.S. CLS. 2, 13, 23, 29, 30, 33, 40 AND 50).  
FIRST USE 9-30-2010; IN COMMERCE 9-30-2010.

THE MARK CONSISTS OF STANDARD CHARACTERS WITHOUT CLAIM TO ANY PARTICULAR FONT, STYLE, SIZE, OR COLOR.  
FOR GLASS PRISMS FOR USE AS MNEMONIC DEVICES (U.S. CLS. 2, 13, 23, 29, 30, 33, 40 AND 50).  
FIRST USE 9-30-2010; IN COMMERCE 9-30-2010.

---

3,941,667. REMEMBER2REMEMBER, INC., MARIETTA, GA.  
SN 77-897,712. PUB. 5-11-2010, FILED 12-20-2009.

---

3,941,670. REMEMBER2REMEMBER, INC., MARIETTA, GA.  
SN 77-897,715. PUB. 5-11-2010, FILED 12-20-2009.

# EFFORTLESS PURITY

# GRAFTED IN

THE MARK CONSISTS OF STANDARD CHARACTERS WITHOUT CLAIM TO ANY PARTICULAR FONT, STYLE, SIZE, OR COLOR.  
FOR GLASS PRISMS FOR USE AS MNEMONIC DEVICES (U.S. CLS. 2, 13, 23, 29, 30, 33, 40 AND 50).  
FIRST USE 9-30-2010; IN COMMERCE 9-30-2010.

THE MARK CONSISTS OF STANDARD CHARACTERS WITHOUT CLAIM TO ANY PARTICULAR FONT, STYLE, SIZE, OR COLOR.  
FOR GLASS PRISMS FOR USE AS MNEMONIC DEVICES (U.S. CLS. 2, 13, 23, 29, 30, 33, 40 AND 50).  
FIRST USE 9-30-2010; IN COMMERCE 9-30-2010.

---

3,941,668. REMEMBER2REMEMBER, INC., MARIETTA, GA.  
SN 77-897,713. PUB. 5-11-2010, FILED 12-20-2009.

---

3,941,671. REMEMBER2REMEMBER, INC., MARIETTA, GA.  
SN 77-897,716. PUB. 5-11-2010, FILED 12-20-2009.

# TOUCHED

# JUST KNOWING

THE MARK CONSISTS OF STANDARD CHARACTERS WITHOUT CLAIM TO ANY PARTICULAR FONT, STYLE, SIZE, OR COLOR.  
FOR GLASS PRISMS FOR USE AS MNEMONIC DEVICES (U.S. CLS. 2, 13, 23, 29, 30, 33, 40 AND 50).  
FIRST USE 9-30-2010; IN COMMERCE 9-30-2010.

THE MARK CONSISTS OF STANDARD CHARACTERS WITHOUT CLAIM TO ANY PARTICULAR FONT, STYLE, SIZE, OR COLOR.  
FOR GLASS PRISMS FOR USE AS MNEMONIC DEVICES (U.S. CLS. 2, 13, 23, 29, 30, 33, 40 AND 50).  
FIRST USE 9-30-2010; IN COMMERCE 9-30-2010.

**CLASS 21—(Continued).**

3,941,679. REMEMBER2REMEMBER, INC., MARIETTA, GA.  
SN 77-898,351. PUB. 5-11-2010, FILED 12-21-2009.

**HIS VERY DNA**

THE MARK CONSISTS OF STANDARD CHARACTERS WITHOUT CLAIM TO ANY PARTICULAR FONT, STYLE, SIZE, OR COLOR.

FOR GLASS PRISMS FOR USE AS MNEMONIC DEVICES (U.S. CLS. 2, 13, 23, 29, 30, 33, 40 AND 50).  
FIRST USE 9-30-2010; IN COMMERCE 9-30-2010.

3,941,687. REMEMBER2REMEMBER, INC., MARIETTA, GA.  
SN 77-899,579. PUB. 5-11-2010, FILED 12-22-2009.

**LET IT FLOW**

THE MARK CONSISTS OF STANDARD CHARACTERS WITHOUT CLAIM TO ANY PARTICULAR FONT, STYLE, SIZE, OR COLOR.

FOR GLASS PRISMS FOR USE AS MNEMONIC DEVICES (U.S. CLS. 2, 13, 23, 29, 30, 33, 40 AND 50).  
FIRST USE 9-30-2010; IN COMMERCE 9-30-2010.

3,941,702. JOHNSON, STANLEY A., STURGEON BAY, WI.  
SN 77-901,386. PUB. 6-8-2010, FILED 12-28-2009.



OWNER OF U.S. REG. NO. 3,607,171.

NO CLAIM IS MADE TO THE EXCLUSIVE RIGHT TO USE "MADISON" AND "WIS. USA" AND "STRENGTH" AND "DURABILITY", APART FROM THE MARK AS SHOWN.

THE COLOR(S) RED, GOLD AND BLACK IS/ARE CLAIMED AS A FEATURE OF THE MARK.

THE MARK CONSISTS OF TWO CONCENTRIC CIRCLES WITH THREE INTERCONNECTED LINKS OF CHAIN

**CLASS 21—(Continued).**

FORMING A TRIANGLE WITH THE WORDS IN THE MIDDLE OF THE INNER CIRCLE. THE WORDING "STRENGTH" APPEARS IN THE LEFT SIDE LINK, THE WORDING "DURABILITY" APPEARS IN THE RIGHT SIDE LINK, AND THE WORDING "ECONOMY" APPEARS IN THE BOTTOM LINK, ALL OF THOSE WORDS APPEARING IN BLACK. ABOVE THE LINKS IS THE WORDING "FULLER", AN AMPERSAND (&) APPEARS IN THE MIDDLE TRIANGLE FORMED BY THE CHAIN LINKS AND THE WORDING "JOHNSON" APPEARS UNDERNEATH THE LINKS, ALL OF THAT WORDING APPEARING IN GOLD WITH BLACK OUTLINE. THE WORDING "MADISON" IS IN GOLD TO THE LEFT OF THE CHAIN LINKS AND "WIS. U.S.A." IS IN GOLD TO THE RIGHT OF THE CHAIN LINK. THE INNER CIRCLE IS IN RED, THE OUTER CIRCLE AND CHAIN LINKS AND AMPERSAND ARE IN GOLD WITH BLACK OUTLINE.

FOR CARDBOARD CUPS; COFFEE CUPS; COFFEE CUPS, TEA CUPS AND MUGS; COMMEMORATIVE PLATES; CUPS; CUPS AND MUGS; DECORATIVE PLATES; DRINKING GLASSES; GLASS BEVERAGEWARE; GLASS DISHES; GLASS JARS; GLASS MUGS; PAPER AND PLASTIC CUPS; PAPER CUPS; PAPER PLATES; PAPER PLATES AND PAPER CUPS; PAPER TRAYS; PLASTIC CUPS; PLASTIC PLATES; PRESERVE GLASSES; STAINED GLASS; WINE GLASSES (U.S. CLS. 2, 13, 23, 29, 30, 33, 40 AND 50).  
FIRST USE 1-1-2005; IN COMMERCE 1-1-2005.

3,941,779. POSITIVE OUTCOMES, INC., WILDWOOD, MO.  
SN 77-915,651. PUB. 6-8-2010, FILED 1-20-2010.

**CAN-IN-BALL**

THE MARK CONSISTS OF STANDARD CHARACTERS WITHOUT CLAIM TO ANY PARTICULAR FONT, STYLE, SIZE, OR COLOR.

FOR INSULATED CONTAINERS FOR BEVERAGE CANS AND BOTTLES FOR PERSONAL USE (U.S. CLS. 2, 13, 23, 29, 30, 33, 40 AND 50).

FIRST USE 7-1-2010; IN COMMERCE 7-1-2010.

3,941,819. BIG TIME HOLDINGS, INC., ROME, GA. SN 77-920,492. PUB. 6-8-2010, FILED 1-26-2010.

**DIGZ**

THE MARK CONSISTS OF STANDARD CHARACTERS WITHOUT CLAIM TO ANY PARTICULAR FONT, STYLE, SIZE, OR COLOR.

FOR GARDENING GLOVES (U.S. CLS. 2, 13, 23, 29, 30, 33, 40 AND 50).

FIRST USE 5-3-2010; IN COMMERCE 5-3-2010.

**CLASS 21—(Continued).**

3,941,820. BIG TIME HOLDINGS, INC., ROME, GA. SN 77-920,493. PUB. 6-8-2010, FILED 1-26-2010.

**GET YOUR DIGZ ON**

THE MARK CONSISTS OF STANDARD CHARACTERS WITHOUT CLAIM TO ANY PARTICULAR FONT, STYLE, SIZE, OR COLOR.

FOR GARDENING GLOVES (U.S. CLS. 2, 13, 23, 29, 30, 33, 40 AND 50).

FIRST USE 5-3-2010; IN COMMERCE 5-3-2010.

**CLASS 21—(Continued).**

3,942,114. JELLY BELLY CANDY COMPANY, FAIRFIELD, CA. SN 85-017,412. PUB. 12-7-2010, FILED 4-19-2010.

**MYSTERY BEAN MACHINE**

THE MARK CONSISTS OF STANDARD CHARACTERS WITHOUT CLAIM TO ANY PARTICULAR FONT, STYLE, SIZE, OR COLOR.

NO CLAIM IS MADE TO THE EXCLUSIVE RIGHT TO USE "BEAN MACHINE", APART FROM THE MARK AS SHOWN.

FOR CANDY BOXES (U.S. CLS. 2, 13, 23, 29, 30, 33, 40 AND 50).

FIRST USE 8-31-2010; IN COMMERCE 8-31-2010.

3,941,983. CHURCH & DWIGHT CO., INC., PRINCETON, NJ. SN 77-962,343. PUB. 6-29-2010, FILED 3-18-2010.

**GLOBRUSH**

THE MARK CONSISTS OF STANDARD CHARACTERS WITHOUT CLAIM TO ANY PARTICULAR FONT, STYLE, SIZE, OR COLOR.

FOR TOOTHBRUSHES (U.S. CLS. 2, 13, 23, 29, 30, 33, 40 AND 50).

FIRST USE 1-24-2011; IN COMMERCE 1-24-2011.

3,942,197. EVRIHOLDER PRODUCTS LLC, ANAHEIM, CA. SN 85-050,244. PUB. 11-2-2010, FILED 5-28-2010.

**TRAIN BYTES**

THE MARK CONSISTS OF STANDARD CHARACTERS WITHOUT CLAIM TO ANY PARTICULAR FONT, STYLE, SIZE, OR COLOR.

NO CLAIM IS MADE TO THE EXCLUSIVE RIGHT TO USE "TRAIN", APART FROM THE MARK AS SHOWN.

FOR BREAD AND SANDWICH CRUST CUTTER IN THE NATURE OF A COOKIE CUTTER THAT REMOVES THE CRUST OF BREAD AND CREATES A FANCIFUL SHAPE (U.S. CLS. 2, 13, 23, 29, 30, 33, 40 AND 50).

FIRST USE 5-3-2010; IN COMMERCE 6-4-2010.

3,942,032. CRISA LIBBEY MEXICO, S. DE R.L. DE C.V., 64580 MONTERREY, N.L., MEXICO. SN 77-981,294. PUB. 1-19-2010, FILED 8-19-2009.

**BOROCLASS**

THE MARK CONSISTS OF STANDARD CHARACTERS WITHOUT CLAIM TO ANY PARTICULAR FONT, STYLE, SIZE, OR COLOR.

FOR HOUSEHOLD UTENSILS, NAMELY, GLASS JARS FOR ELECTRIC FOOD BLENDERS; GLASS BOWLS FOR ELECTRIC FOOD MIXERS (U.S. CLS. 2, 13, 23, 29, 30, 33, 40 AND 50).

FIRST USE 1-0-2006; IN COMMERCE 1-0-2006.

**CLASS 24—FABRICS**

3,940,994. MARGARET A. DAVIS, BERNARDSVILLE, NJ. SN 76-700,080. PUB. 8-10-2010, FILED 10-27-2009.

**GO-GO BLANKET**

THE MARK CONSISTS OF STANDARD CHARACTERS WITHOUT CLAIM TO ANY PARTICULAR FONT, STYLE, SIZE, OR COLOR.

NO CLAIM IS MADE TO THE EXCLUSIVE RIGHT TO USE "BLANKET", APART FROM THE MARK AS SHOWN.

FOR CHILDREN'S TRAVEL BLANKETS WITH SLEEVES AND AN OPEN BACK FOR USE WITH INFANTS SECURED IN A CAR SEAT (U.S. CLS. 42 AND 50).

FIRST USE 11-22-2010; IN COMMERCE 11-22-2010.

**CLASS 24—(Continued).**

3,941,099. JUICY COUTURE, INC., PACOIMA, CA. SN 77-509,864. PUB. 11-11-2008, FILED 6-27-2008.

## JUICY COUTURE

THE MARK CONSISTS OF STANDARD CHARACTERS WITHOUT CLAIM TO ANY PARTICULAR FONT, STYLE, SIZE, OR COLOR.

NO CLAIM IS MADE TO THE EXCLUSIVE RIGHT TO USE "COUTURE", APART FROM THE MARK AS SHOWN. FOR BED BLANKETS; BED COVERS; BED SHEETS; BLANKET THROWS; DUVET COVERS; PILLOW CASES; PILLOW COVERS; TOWELS (U.S. CLS. 42 AND 50).

FIRST USE 6-0-2009; IN COMMERCE 6-0-2009.

**CLASS 24—(Continued).**

3,941,243. MECYRUS INC, ARCADIA, CA. SN 77-696,442. PUB. 7-28-2009, FILED 3-22-2009.



## MECYRUS

THE MARK CONSISTS OF A DESIGN OF AN ORIENTAL LOOKING TROPHY SURROUNDED BY A FULL CIRCLE, WITH THE WORD "MECYRUS" AT THE BOTTOM.

FOR BED BLANKETS; BED COVERS; BED LINEN; BED SHEETS; BED SKIRTS; BED SPREADS (U.S. CLS. 42 AND 50).

FIRST USE 7-1-2010; IN COMMERCE 7-1-2010.

3,941,307. SEFTE LIVING, LLC, SAN FRANCISCO, NJ. SN 77-761,675. PUB. 11-24-2009, FILED 6-17-2009.

## SEFTE LIVING

THE MARK CONSISTS OF STANDARD CHARACTERS WITHOUT CLAIM TO ANY PARTICULAR FONT, STYLE, SIZE, OR COLOR.

FOR LINENS, NAMELY, FABRIC; BED AND TABLE LINEN; BEDDING, NAMELY, SHEETS AND BLANKETS FOR BEDS (U.S. CLS. 42 AND 50).

FIRST USE 1-31-2010; IN COMMERCE 1-31-2010.

3,941,162. US AIRWAYS, INC., TEMPE, AZ. SN 77-613,012. PUB. 6-1-2010, FILED 11-12-2008.

## US AIRWAYS POWER-NAP SACK

THE MARK CONSISTS OF STANDARD CHARACTERS WITHOUT CLAIM TO ANY PARTICULAR FONT, STYLE, SIZE, OR COLOR.

OWNER OF U.S. REG. NOS. 2,337,561, 2,368,986, AND OTHERS.

NO CLAIM IS MADE TO THE EXCLUSIVE RIGHT TO USE "POWER-NAP SACK", APART FROM THE MARK AS SHOWN.

SEC. 2(F) AS TO "US AIRWAYS".

FOR IN-FLIGHT COMFORT KITS CONSISTING OF BLANKETS, PILLOWS, EYESHADES, AND EAR PLUGS (U.S. CLS. 42 AND 50).

FIRST USE 1-1-2009; IN COMMERCE 3-0-2009.

3,941,446. LAURA HAGAN, DBA MY BOBOLINO, FLORAL PARK, NY. SN 77-818,074. PUB. 2-2-2010, FILED 9-2-2009.

## Cover-Me Burpie

THE MARK CONSISTS OF STANDARD CHARACTERS WITHOUT CLAIM TO ANY PARTICULAR FONT, STYLE, SIZE, OR COLOR.

NO CLAIM IS MADE TO THE EXCLUSIVE RIGHT TO USE "BURPIE", APART FROM THE MARK AS SHOWN.

FOR BURP CLOTHS (U.S. CLS. 42 AND 50). FIRST USE 1-1-2011; IN COMMERCE 2-18-2011.

**CLASS 24—(Continued).**

3,941,532. MARY B. PALAZZO, MONMOUTH BEACH, NJ. AND ELIZABETH B. PALAZZO, MONMOUTH BEACH, NJ. AND KOREN K. PALAZZO-SPADAVECCHIA, MONMOUTH BEACH, NJ. SN 77-864,430. PUB. 4-27-2010, FILED 11-4-2009.

**NANNY TEDDY**

THE MARK CONSISTS OF STANDARD CHARACTERS WITHOUT CLAIM TO ANY PARTICULAR FONT, STYLE, SIZE, OR COLOR.

FOR BED BLANKETS; CHILDREN'S BLANKETS; QUILTS OF TEXTILE; RECEIVING BLANKETS (U.S. CLS. 42 AND 50).

FIRST USE 1-1-2010; IN COMMERCE 1-1-2010.

3,941,711. VOLLRATH, EDWARD L., TOMS RIVER, NJ. SN 77-903,205. PUB. 5-18-2010, FILED 12-30-2009.

**Skutch**

THE MARK CONSISTS OF STANDARD CHARACTERS WITHOUT CLAIM TO ANY PARTICULAR FONT, STYLE, SIZE, OR COLOR.

FOR BLANKET THROWS; BLANKETS FOR OUTDOOR USE; CHILDREN'S BLANKETS; THROWS; THROWS DESIGNED TO ALSO BE WRAPPED AROUND A PERSON; THROWS FOR TRAVELING (U.S. CLS. 42 AND 50).

FIRST USE 10-1-2009; IN COMMERCE 3-3-2010.

3,941,789. BEACON LOOMS, INC., TEANECK, NJ. SN 77-917,682. PUB. 6-8-2010, FILED 1-22-2010.

**LIGHTCATCHER**

THE MARK CONSISTS OF STANDARD CHARACTERS WITHOUT CLAIM TO ANY PARTICULAR FONT, STYLE, SIZE, OR COLOR.

FOR FABRIC WINDOW COVERINGS AND TREATMENTS, NAMELY, CURTAINS, DRAPERIES; WINDOW TREATMENTS IN NATURE OF FABRIC LININGS (U.S. CLS. 42 AND 50).

FIRST USE 7-16-2010; IN COMMERCE 7-16-2010.

**CLASS 24—(Continued).**

3,941,807. APOLLO INDUSTRIES LIMITED, HANGZHOU, HONG KONG. SN 77-919,906. PUB. 5-11-2010, FILED 1-26-2010.

**MAXTURA**

THE MARK CONSISTS OF STANDARD CHARACTERS WITHOUT CLAIM TO ANY PARTICULAR FONT, STYLE, SIZE, OR COLOR.

FOR TEXTILE FABRICS FOR THE MANUFACTURE OF CLOTHING; TEXTILE FABRICS FOR USE IN THE MANUFACTURE OF GARMENTS, BAGS, JACKETS, GLOVES, AND APPAREL (U.S. CLS. 42 AND 50).

FIRST USE 8-0-2010; IN COMMERCE 8-0-2010.

3,941,889. MARGARET M. KILBANE,, DETROIT LAKES, MN. SN 77-932,482. PUB. 6-22-2010, FILED 2-10-2010.

**LAKEGIRL**

THE MARK CONSISTS OF STANDARD CHARACTERS WITHOUT CLAIM TO ANY PARTICULAR FONT, STYLE, SIZE, OR COLOR.

OWNER OF U.S. REG. NOS. 3,062,427, 3,411,417, AND 3,494,644.

FOR TOWELS (U.S. CLS. 42 AND 50).

FIRST USE 4-30-2010; IN COMMERCE 4-30-2010.

3,941,938. RICHLOOM CORP., NEW YORK, NY. SN 77-946,240. PUB. 7-27-2010, FILED 2-26-2010.

**THRAP**

THE MARK CONSISTS OF STANDARD CHARACTERS WITHOUT CLAIM TO ANY PARTICULAR FONT, STYLE, SIZE, OR COLOR.

FOR BLANKET THROWS, BED BLANKETS, BLANKETS FOR OUTDOOR USE (U.S. CLS. 42 AND 50).

FIRST USE 10-25-2010; IN COMMERCE 10-25-2010.

**CLASS 24—(Continued).**

3,942,087. LEONARD, CHARLOTTE, STARKVILLE, MS. SN 85-004,882. PUB. 8-24-2010, FILED 4-2-2010.



NO CLAIM IS MADE TO THE EXCLUSIVE RIGHT TO USE "BANNERFLAGS", APART FROM THE MARK AS SHOWN.

THE COLOR(S) GREEN IS/ARE CLAIMED AS A FEATURE OF THE MARK.

THE MARK CONSISTS OF A LADY HOLDING A FLAG WITH THE WORDS "RAISED PRAISE BANNERFLAGS" ALL IN GREEN.

FOR BANNERS AND FLAGS OF TEXTILE (U.S. CLS. 42 AND 50).

FIRST USE 8-14-2010; IN COMMERCE 8-21-2010.

3,942,230. ALEXANDER JULIAN, INC., RIDGEFIELD, CT. SN 85-056,212. PUB. 11-16-2010, FILED 6-7-2010.

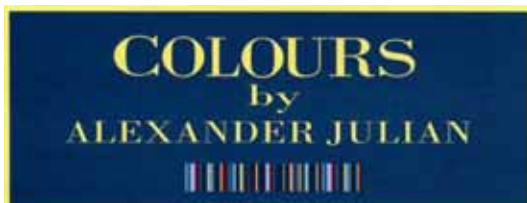

OWNER OF U.S. REG. NOS. 1,303,813, 3,093,489, AND OTHERS.

NO CLAIM IS MADE TO THE EXCLUSIVE RIGHT TO USE "COLOURS", APART FROM THE MARK AS SHOWN.

THE NAME "ALEXANDER JULIAN" IDENTIFIES A LIVING INDIVIDUAL WHOSE CONSENT IS OF RECORD.

THE COLOR(S) DARK BLUE, LIGHT BLUE, ORANGE, BLACK, RED, GREEN AND YELLOW IS/ARE CLAIMED AS A FEATURE OF THE MARK.

THE MARK CONSISTS OF A DARK BLUE RECTANGLE OUTLINED IN YELLOW WITH THE WORDS "COLOURS BY ALEXANDER JULIAN" CONTAINED THEREIN ON THREE LINES OF STYLIZED YELLOW PRINT, SITUATED ABOVE A HORIZONTAL BAR STRIPED IN DARK BLUE, LIGHT BLUE, ORANGE, BLACK, RED, GREEN AND YELLOW.

FOR SHEETS, TOWELS, BEDDING, COMFORTER, QUILTS (U.S. CLS. 42 AND 50).

FIRST USE 5-15-2010; IN COMMERCE 5-15-2010.

**CLASS 25—CLOTHING****CLASS 25—(Continued).**

3,940,979. TATIOSSIAN BROTHERS INC., SUN VALLEY, CA. SN 76-664,702. PUB. 3-30-2010, FILED 8-16-2006.

**NAPA FLEX**

THE MARK CONSISTS OF STANDARD CHARACTERS WITHOUT CLAIM TO ANY PARTICULAR FONT, STYLE, SIZE, OR COLOR.

FOR MEN'S AND WOMEN'S SHOES (U.S. CLS. 22 AND 39).

FIRST USE 1-19-2011; IN COMMERCE 1-19-2011.

3,940,987. LONG, ROBERT EMERSON, NEWAYGO, MI. SN 76-695,346. PUB. 5-25-2010, FILED 1-16-2009.



FOR CLOTHING, NAMELY, SHIRTS, HATS, PANTS, FOOTWEAR AND HEADWEAR (U.S. CLS. 22 AND 39).

FIRST USE 9-15-2008; IN COMMERCE 2-25-2009.

3,940,997. WALLS INDUSTRIES, INC., CLEBURNE, TEXAS, CLEBURNE, TX. SN 76-701,223. PUB. 5-11-2010, FILED 1-19-2010.

**WALLS**

THE MARK CONSISTS OF STANDARD CHARACTERS WITHOUT CLAIM TO ANY PARTICULAR FONT, STYLE, SIZE, OR COLOR.

OWNER OF U.S. REG. NOS. 2,571,382, 3,327,679, AND OTHERS.

FOR CLOTHING, NAMELY, PARKAS, SHOOTING JACKETS, SHOOTING COATS, HUNTING JACKETS, HUNTING COATS; HUNTING SUIT, SPORTS COATS, BUSH COATS, SAFARI COATS, CAMOUFLAGE JACKETS, PANTS, PONCHOS, SHIRT JACKETS, SHORTS, INSULATED HOODS, SWEATERS, UNDERWEAR, SOCKS, HOSIERY, HATS, BELTS, FOOTWEAR AND HEADWEAR (U.S. CLS. 22 AND 39).

FIRST USE 0-0-1945; IN COMMERCE 0-0-1945.

**CLASS 25—(Continued).**

3,940,998. WALLS INDUSTRIES, INC., CLEBURNE, TEXAS, CLEBURNE, TX. SN 76-701,224. PUB. 5-11-2010, FILED 1-19-2010.

**LIBERTY**

THE MARK CONSISTS OF STANDARD CHARACTERS WITHOUT CLAIM TO ANY PARTICULAR FONT, STYLE, SIZE, OR COLOR.

OWNER OF U.S. REG. NOS. 1,084,058, 3,376,029, AND OTHERS.

FOR CLOTHING, NAMELY, OVERALLS, TROUSERS, SLACKS, JACKETS, SUITS, SHIRTS, JEANS, BLOUSES, INSULATED JACKETS; INSULATED COVERALLS; INSULATED OVERALLS; PANTS, SWEATERS; CAMOUFLAGE CLOTHING, NAMELY, JACKETS, PANTS, SHIRTS; GLOVES, SHOES, SOCKS, HOSIERY, HATS, BELTS (U.S. CLS. 22 AND 39).

FIRST USE 0-0-1996; IN COMMERCE 0-0-1996.

3,940,999. WALLS INDUSTRIES, INC., CLEBURNE, TEXAS, CLEBURNE, TX. SN 76-701,227. PUB. 5-11-2010, FILED 1-19-2010.

**10X**

THE MARK CONSISTS OF STANDARD CHARACTERS WITHOUT CLAIM TO ANY PARTICULAR FONT, STYLE, SIZE, OR COLOR.

OWNER OF U.S. REG. NOS. 1,153,248, 3,149,614, AND OTHERS.

FOR CLOTHING, NAMELY, SHOOTING JACKETS, SHOOTING COATS, HUNTING COATS, OVERCOATS, JACKETS, VESTS, COVERALLS, PARKAS, INSULATED SUITS, INSULATED COATS, HUNTINGJACKETS, OVERALLS, JEANS, SPORT COATS, BUSH COATS, SAFARI COATS, CAMOUFLAGE SUITS, PANTS, HUNTING PANTS, SHOOTING PANTS, HUNTING SUITS, PONCHOS, SHIRTS, SHIRT JACKETS, INSULATED HOODS, CAPS, HATS, INSULATED SWEATERS, INSULATED UNDERWEAR, HIKING BOOTS, SHOES, GLOVES, SOCKS, HOSIERY, AND BELTS (U.S. CLS. 22 AND 39).

FIRST USE 0-0-1970; IN COMMERCE 0-0-1970.

**CLASS 25—(Continued).**

3,941,016. OUT OF THE BLUE ENTERPRISES LLC, NEW YORK, NY. SN 77-071,797. PUB. 3-18-2008, FILED 12-27-2006.

**SUPER WHY**

THE MARK CONSISTS OF STANDARD CHARACTERS WITHOUT CLAIM TO ANY PARTICULAR FONT, STYLE, SIZE, OR COLOR.

FOR HALLOWEEN COSTUMES, T-SHIRTS, SWEATSHIRTS, UNDERCLOTHES (U.S. CLS. 22 AND 39).

FIRST USE 10-0-2008; IN COMMERCE 10-0-2008.

3,941,022. GOODWYN JR., LEE L., ALEXANDRIA, VA. SN 77-135,349. PUB. 6-24-2008, FILED 3-20-2007.

**Sez[suhm]**

FOR CLOTHING, NAMELY, T-SHIRTS, TANK TOPS, SWEATSHIRTS, HOODED SWEATSHIRTS, SWEATERS, JEANS, DENIM JEANS, SOCKS, JACKETS, COATS, SKIRTS, SHORTS, DRESSES, BELTS, CAPS, HATS, HANDBAGS, SHOES, BLAZERS, POLO SHIRTS (U.S. CLS. 22 AND 39).

FIRST USE 2-14-2011; IN COMMERCE 2-14-2011.

3,941,025. FRANKLIN COUNTY HISTORICAL SOCIETY, COLUMBUS, OH. SN 77-188,299. PUB. 12-9-2008, FILED 5-23-2007.

**LITTLE KIDSPACE**

THE MARK CONSISTS OF STANDARD CHARACTERS WITHOUT CLAIM TO ANY PARTICULAR FONT, STYLE, SIZE, OR COLOR.

OWNER OF U.S. REG. NOS. 1,571,058, 1,571,353, AND 2,434,241.

FOR T-SHIRTS (U.S. CLS. 22 AND 39). FIRST USE 6-0-2009; IN COMMERCE 6-0-2009.

**CLASS 25—(Continued).**

3,941,033. TEUTLOFF, JORN K, SANTA MONICA, CA. SN 77-222,092. PUB. 4-29-2008, FILED 7-4-2007.

## Santies

THE MARK CONSISTS OF STANDARD CHARACTERS WITHOUT CLAIM TO ANY PARTICULAR FONT, STYLE, SIZE, OR COLOR.

FOR UNDERWEAR (U.S. CLS. 22 AND 39).  
FIRST USE 1-1-2011; IN COMMERCE 1-1-2011.

3,941,087. QUIN, SUSAN M, WOODBURY HEIGHTS, NJ. SN 77-476,645. PUB. 2-17-2009, FILED 5-16-2008.



THE COLOR(S) ORANGE, BLACK, WHITE AND RED IS/ ARE CLAIMED AS A FEATURE OF THE MARK.

THE MARK CONSISTS OF THE MARK CONSISTS OF A WORM HOLDING A FISHING HOOK WITH A ROPE ATTACHED AND THE WORD "FIERCE FISHING".

FOR SHORT-SLEEVED OR LONG-SLEEVED T-SHIRTS, HATS, HOODED SWEATSHIRTS, JACKETS, SHORTS (U.S. CLS. 22 AND 39).

FIRST USE 6-1-2010; IN COMMERCE 6-1-2010.

**CLASS 25—(Continued).**

3,941,107. STERLING, PATRICK B., COLFAX, NC. SN 77-520,963. PUB. 12-2-2008, FILED 7-13-2008.

## Technoporters

THE MARK CONSISTS OF STANDARD CHARACTERS WITHOUT CLAIM TO ANY PARTICULAR FONT, STYLE, SIZE, OR COLOR.

FOR BELTS; BIBS NOT OF CLOTH OR PAPER; CAPS; CHILDREN'S AND INFANTS' CLOTH BIBS; CHILDREN'S CLOTH EATING BIBS; CLOTH BIBS; CLOTH BIBS FOR ADULT DINERS; CLOTH DIAPERS; MOISTURE-WICKING SPORTS BRAS; MOISTURE-WICKING SPORTS PANTS; MOISTURE-WICKING SPORTS SHIRTS; MUFLERS; NON-DISPOSABLE CLOTH TRAINING PANTS; PARTS OF CLOTHING, NAMELY, GUSSETS FOR TIGHTS, GUSSETS FOR STOCKINGS, GUSSETS FOR BATHING SUITS, GUSSETS FOR UNDERWEAR, GUSSETS FOR LEOTARDS AND GUSSETS FOR FOOTLETS; SHORT SETS; SHOULDER WRAPS; SPORT SHIRTS; SPORTS BRA; SPORTS BRAS; SPORTS JACKETS; SPORTS JERSEYS; SPORTS JERSEYS AND BREECHES FOR SPORTS; SPORTS OVERUNIFORMS; SPORTS PANTS; SPORTS SHIRTS; SPORTS SHIRTS WITH SHORT SLEEVES; SWADDLING CLOTHES; TIES; TOPS; TRAVEL CLOTHING CONTAINED IN A PACKAGE COMPRISING REVERSIBLE JACKETS, PANTS, SKIRTS, TOPS AND A BELT OR SCARF; TRIATHLON CLOTHING, NAMELY, TRIATHLON TIGHTS, TRIATHLON SHORTS, TRIATHLON SINGLET, TRIATHLON SHIRTS, TRIATHLON SUITS; WEARABLE GARMENTS AND CLOTHING, NAMELY, SHIRTS; WRAPS (U.S. CLS. 22 AND 39).

FIRST USE 9-28-2009; IN COMMERCE 11-12-2009.

3,941,123. GRATEFUL GRAFFITI, BEVERLY HILLS, CA. SN 77-550,030. PUB. 3-31-2009, FILED 8-19-2008.

## GRATEFUL GRAFFITI

THE MARK CONSISTS OF STANDARD CHARACTERS WITHOUT CLAIM TO ANY PARTICULAR FONT, STYLE, SIZE, OR COLOR.

OWNER OF U.S. REG. NO. 3,563,674.

NO CLAIM IS MADE TO THE EXCLUSIVE RIGHT TO USE "GRAFFITI", APART FROM THE MARK AS SHOWN.

FOR CLOTHING FOR MEN, WOMEN AND CHILDREN, NAMELY, T-SHIRTS, SWEATSHIRTS, BLOUSES, SWEATERS, PULLOVERS, TOPS, TANK TOPS, JACKETS, COATS, SHIRTS, VESTS, UNDERWEAR, BRASSIERES, NIGHTGOWNS, PYJAMAS, BATHROBES, TIGHTS, DRESSES, SKIRTS, TROUSERS, PANTS, JEANS, SHORTS, APRONS, SWEATPANTS, SWIMSUITS, HATS, CAPS, HEADBANDS, SUN VISORS, BELTS, SCARVES, TIES, GLOVES, SOCKS, SANDALS, SLIPPERS, BOOTS, SHOES, FOOTWEAR FOR SPORTS (U.S. CLS. 22 AND 39).

FIRST USE 10-1-2010; IN COMMERCE 10-1-2010.



**CLASS 25—(Continued).**

3,941,153. COCKY JOCKS, LLC, DENT, MN. SN 77-602,710.  
PUB. 4-21-2009, FILED 10-29-2008.

**JONNY JOCKS**

THE MARK CONSISTS OF STANDARD CHARACTERS WITHOUT CLAIM TO ANY PARTICULAR FONT, STYLE, SIZE, OR COLOR.

THE NAME SHOWN IN THE MARK DOES NOT IDENTIFY A PARTICULAR LIVING INDIVIDUAL.

FOR MEN'S CLOTHING, NAMELY, SHIRTS, PANTS, SHORTS, UNDERWEAR, JACKETS, COATS, WRISTBANDS, AND HEADGEAR, NAMELY, CAPS AND HATS (U.S. CLS. 22 AND 39).

FIRST USE 7-5-2010; IN COMMERCE 7-5-2010.

---

3,941,154. COCKY JOCKS, LLC, DENT, MN. SN 77-602,712.  
PUB. 4-21-2009, FILED 10-29-2008.

**JENNY JOCKS**

THE MARK CONSISTS OF STANDARD CHARACTERS WITHOUT CLAIM TO ANY PARTICULAR FONT, STYLE, SIZE, OR COLOR.

THE NAME SHOWN IN THE MARK DOES NOT IDENTIFY A PARTICULAR LIVING INDIVIDUAL.

FOR WOMEN'S CLOTHING, NAMELY, SHIRTS, KNIT TOPS, PANTS, SHORTS, UNDERWEAR, JACKETS, COATS, WRISTBANDS, AND HEADGEAR, NAMELY, CAPS AND HATS (U.S. CLS. 22 AND 39).

FIRST USE 7-5-2010; IN COMMERCE 7-5-2010.

---

3,941,185. DIANE UHLENKAMP, AURORA, CO. SN 77-639,899. PUB. 5-25-2010, FILED 12-24-2008.

**DO YOUR ENERGY**

THE MARK CONSISTS OF STANDARD CHARACTERS WITHOUT CLAIM TO ANY PARTICULAR FONT, STYLE, SIZE, OR COLOR.

FOR CLOTHING, NAMELY, INFANT WEAR, JACKETS, LOUNGEWEAR, PANTS, SHIRTS, SHORTS, SLEEPWEAR, SWEATSHIRTS, TANK TOPS, T-SHIRTS AND WARM UP SUITS; AND HEADWEAR (U.S. CLS. 22 AND 39).

FIRST USE 4-25-2009; IN COMMERCE 4-25-2009.

**CLASS 25—(Continued).**

3,941,190. PLAYBOY ENTERPRISES INTERNATIONAL, INC., CHICAGO, IL. SN 77-644,314. PUB. 4-14-2009, FILED 1-6-2009.

**Rock the Rabbit**

THE MARK CONSISTS OF STANDARD CHARACTERS WITHOUT CLAIM TO ANY PARTICULAR FONT, STYLE, SIZE, OR COLOR.

OWNER OF U.S. REG. NO. 3,446,016.  
FOR SHIRTS; T-SHIRTS (U.S. CLS. 22 AND 39).  
FIRST USE 7-1-2009; IN COMMERCE 7-1-2009.

---

3,941,192. HENDERSON, TIM, CHICO, CA. SN 77-646,386.  
PUB. 4-28-2009, FILED 1-9-2009.

**OLDSCHOOLJOE**

THE MARK CONSISTS OF STANDARD CHARACTERS WITHOUT CLAIM TO ANY PARTICULAR FONT, STYLE, SIZE, OR COLOR.

FOR SHIRTS (U.S. CLS. 22 AND 39).  
FIRST USE 12-7-2010; IN COMMERCE 1-4-2011.

---

3,941,227. ELVIS PRESLEY ENTERPRISES, INC., MEMPHIS, TN. SN 77-674,012. PUB. 6-16-2009, FILED 2-19-2009.

**I WANT YOU I NEED YOU I LOVE YOU**

THE MARK CONSISTS OF STANDARD CHARACTERS WITHOUT CLAIM TO ANY PARTICULAR FONT, STYLE, SIZE, OR COLOR.

FOR CLOTHING, NAMELY, SHIRTS, T-SHIRTS, SWEATSHIRTS, CAPS, SHORTS AND PANTS (U.S. CLS. 22 AND 39).

FIRST USE 5-18-2010; IN COMMERCE 5-18-2010.

**CLASS 25—(Continued).**

3,941,229. ELVIS PRESLEY ENTERPRISES, INC., MEMPHIS, TN. SN 77-678,299. PUB. 6-16-2009, FILED 2-25-2009.

**FOLLOW THAT DREAM**

THE MARK CONSISTS OF STANDARD CHARACTERS WITHOUT CLAIM TO ANY PARTICULAR FONT, STYLE, SIZE, OR COLOR.

FOR CLOTHING, NAMELY, SHIRTS, T-SHIRTS, SWEATSHIRTS, CAPS, SHORTS AND PANTS (U.S. CLS. 22 AND 39).

FIRST USE 3-10-2010; IN COMMERCE 3-10-2010.

3,941,235. WERAS, INC., OZONE PARK, NY. SN 77-684,366. PUB. 7-7-2009, FILED 3-5-2009.

**AM TALKING**

THE MARK CONSISTS OF STANDARD CHARACTERS WITHOUT CLAIM TO ANY PARTICULAR FONT, STYLE, SIZE, OR COLOR.

FOR BOTTOMS; CAPS; HATS; HEADGEAR, NAMELY, HATS, CAPS; SHIRTS; T-SHIRTS; TOPS (U.S. CLS. 22 AND 39).

FIRST USE 5-0-2010; IN COMMERCE 5-0-2010.

3,941,282. C. & J. CLARK INTERNATIONAL LIMITED, STREET, SOMERSET, UNITED KINGDOM. SN 77-749,970. PUB. 10-13-2009, FILED 6-2-2009.

**CLARKS ELEMENTS**

THE MARK CONSISTS OF STANDARD CHARACTERS WITHOUT CLAIM TO ANY PARTICULAR FONT, STYLE, SIZE, OR COLOR.

OWNER OF U.S. REG. NOS. 540,599, 1,436,513, AND OTHERS.

FOR FOOTWEAR FOR MEN AND WOMEN, EXCLUDING SKATEBOARD FOOTWEAR, WATER SPORTS FOOTWEAR, BOARD SPORTS FOOTWEAR, AND SNEAKERS (U.S. CLS. 22 AND 39).

FIRST USE 12-15-2009; IN COMMERCE 12-15-2009.

**CLASS 25—(Continued).**

3,941,283. THE EXPRESS CAFE & BAKERY, LLC, SAVANNAH, GA. SN 77-751,169. PUB. 10-13-2009, FILED 6-3-2009.

**GOOSE FEATHERS**

THE MARK CONSISTS OF STANDARD CHARACTERS WITHOUT CLAIM TO ANY PARTICULAR FONT, STYLE, SIZE, OR COLOR.

FOR APRONS; SWEAT SHIRTS; T-SHIRTS (U.S. CLS. 22 AND 39).

FIRST USE 9-1-2010; IN COMMERCE 9-1-2010.

3,941,323. COUG & COMPANY INC., BURLINGTON, CANADA. SN 77-766,075. PUB. 11-10-2009, FILED 6-23-2009.

**STORM BY COUGAR**

THE MARK CONSISTS OF STANDARD CHARACTERS WITHOUT CLAIM TO ANY PARTICULAR FONT, STYLE, SIZE, OR COLOR.

PRIORITY CLAIMED UNDER SEC. 44(D) ON CANADA APPLICATION NO. 1,442,004, FILED 6-18-2009.

FOR BOOTS (U.S. CLS. 22 AND 39).

FIRST USE 8-1-2010; IN COMMERCE 9-29-2010.

3,941,333. RU OUTSIDE THE BOX?, LLC, RICHMOND, RI. SN 77-770,839. PUB. 11-17-2009, FILED 6-30-2009.

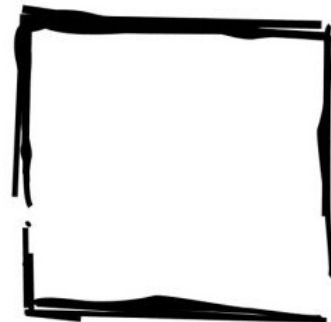

Are you outside the box?

THE MARK CONSISTS OF A SQUARE LOGO WITH THE WORDS "ARE YOU OUTSIDE THE BOX?" POSITIONED THERE BENEATH.

FOR HATS; SCARFS; SHIRTS; SWEAT SHIRTS (U.S. CLS. 22 AND 39).

FIRST USE 8-0-2009; IN COMMERCE 8-0-2009.

**CLASS 25—(Continued).**

3,941,334. CARR, CLINTON, BROOKLYN, NY. SN 77-771,143.  
PUB. 11-17-2009, FILED 6-30-2009.

**VISION HEART**

THE MARK CONSISTS OF STANDARD CHARACTERS WITHOUT CLAIM TO ANY PARTICULAR FONT, STYLE, SIZE, OR COLOR.

FOR BASEBALL CAPS; CAPS WITH VISORS; COATS; GOLF SHIRTS; HATS; HOODED SWEAT SHIRTS; JACKETS; LONG-SLEEVED SHIRTS; PANTS; SHIRTS; SHORT-SLEEVED OR LONG-SLEEVED T-SHIRTS; SHORTS; SPORTS SHIRTS; SPORTS SHIRTS WITH SHORT SLEEVES; SWEAT JACKETS; SWEAT SHIRTS; T-SHIRTS (U.S. CLS. 22 AND 39).

FIRST USE 8-1-2010; IN COMMERCE 8-1-2010.

3,941,376. MILWAUKEE BREWERS BASEBALL CLUB, LIMITED PARTNERSHIP, MILWAUKEE, WI. SN 77-785,563.  
PUB. 12-1-2009, FILED 7-21-2009.



THE MARK CONSISTS OF A BASEBALL PLAYER CHARACTER SWINGING A BASEBALL BAT.

FOR CLOTHING, NAMELY, HEADWEAR, SHIRTS, JACKETS (U.S. CLS. 22 AND 39).

FIRST USE 6-23-2005; IN COMMERCE 6-23-2005.

**CLASS 25—(Continued).**

3,941,383. WELLINGTON'S WORLD LLC, DBA SETH WELLINGTON, PETALUMA, CA. SN 77-789,524. PUB. 6-1-2010, FILED 7-24-2009.



THE MARK CONSISTS OF THREE PERPENDICULAR LINES WITH BASES, THE OUTER LINES HAVING TOPS, AND A COMMA.

FOR MEN'S CLOTHING, NAMELY, SHIRTS, SHORTS, PANTS, TROUSERS, SWEATERS, SWEATSHIRTS, JACKETS, VESTS, LOUNGE PANTS, TIES, BOW TIES, POCKET SQUARES (U.S. CLS. 22 AND 39).

FIRST USE 2-28-2010; IN COMMERCE 2-28-2010.

3,941,391. SALTED SOUL COMPANY, LLC, BOCA RATON, FL. SN 77-793,566. PUB. 5-11-2010, FILED 7-30-2009.

**REEL BURNER**

THE MARK CONSISTS OF STANDARD CHARACTERS WITHOUT CLAIM TO ANY PARTICULAR FONT, STYLE, SIZE, OR COLOR.

FOR SPORT FISHING AND RECREATIONAL FISHING CLOTHING AND APPAREL, NAMELY, BATHING SUITS; BELTS; BOXER BRIEFS; BRIEFS; FLEECE PULL-OVERS; FLIP-FLOPS; HATS; JACKETS; LONG-SLEEVED SHIRTS; PANTS; SHIRTS; SHOES; T-SHIRTS; LONG-SLEEVED T-SHIRTS; SOCKS; SURF WEAR; SWEAT BANDS; SWEAT SHIRTS; SWEATERS; SWIM TRUNKS; TANK TOPS; UNDERWEAR; WET SUITS (U.S. CLS. 22 AND 39).

FIRST USE 1-1-2005; IN COMMERCE 1-1-2011.

3,941,400. ROCKY BRANDS, INC., NELSONVILLE, OH. SN 77-795,215. PUB. 7-6-2010, FILED 8-3-2009.

**MUD SOX**

THE MARK CONSISTS OF STANDARD CHARACTERS WITHOUT CLAIM TO ANY PARTICULAR FONT, STYLE, SIZE, OR COLOR.

**CLASS 25—(Continued).**

NO CLAIM IS MADE TO THE EXCLUSIVE RIGHT TO USE "SOX", APART FROM THE MARK AS SHOWN.  
FOR FOOTWEAR (U.S. CLS. 22 AND 39).  
FIRST USE 6-30-2010; IN COMMERCE 6-30-2010.

3,941,421. TRIBULATION CLOTHING LLC, TUCSON, AZ.  
SN 77-802,824. PUB. 1-12-2010, FILED 8-12-2009.

# Tribulation

THE MARK CONSISTS OF STANDARD CHARACTERS WITHOUT CLAIM TO ANY PARTICULAR FONT, STYLE, SIZE, OR COLOR.

FOR ATHLETIC FOOTWEAR; BELTS; BODY SHIRTS; BOXING SHOES; BOXING SHORTS; CLOTHING FOR ATHLETIC USE, NAMELY, PADDED SHORTS; DRESS SHIRTS; HOODED SWEAT SHIRTS; JERSEYS; JUMPSUITS; POLO SHIRTS; RASH GUARDS; SANDALS; SHOES; SHORTS; SLEEVELESS JERSEYS; SOCKS; SPORTS BRAS; SWEAT SHIRTS; SWIMWEAR; T-SHIRTS; TANK TOPS; THERMAL UNDERWEAR; UNDERWEAR (U.S. CLS. 22 AND 39).

FIRST USE 10-17-2009; IN COMMERCE 11-19-2009.

3,941,424. BRIAN GROOVER, DBA GROOVER CLOTHING, GARDEN GROVE, CA. SN 77-803,911. PUB. 1-12-2010, FILED 8-13-2009.

# Like Mother

THE MARK CONSISTS OF STANDARD CHARACTERS WITHOUT CLAIM TO ANY PARTICULAR FONT, STYLE, SIZE, OR COLOR.

OWNER OF U.S. REG. NO. 2,963,750.  
NO CLAIM IS MADE TO THE EXCLUSIVE RIGHT TO USE "MOTHER", APART FROM THE MARK AS SHOWN.  
FOR T-SHIRTS (U.S. CLS. 22 AND 39).  
FIRST USE 9-1-2010; IN COMMERCE 9-1-2010.

3,941,459. BRENDLEN, JAYLYN, SANTA CRUZ, CA. SN 77-826,109. PUB. 8-24-2010, FILED 9-14-2009.

# DOJA

THE MARK CONSISTS OF STANDARD CHARACTERS WITHOUT CLAIM TO ANY PARTICULAR FONT, STYLE, SIZE, OR COLOR.

**CLASS 25—(Continued).**

THE WORDING "DOJA" HAS NO MEANING IN A FOREIGN LANGUAGE.

FOR CLOTHING, NAMELY, TOPS, TANK TOPS, BLOUSES, SHIRTS, T-SHIRTS, SWEATSHIRTS, CARDIGANS, SWEATERS, BLAZERS, JACKETS, COATS, VESTS, BOTTOMS, PANTS, TROUSERS, JEANS, SWEAT-PANTS, LEGGINGS, SHORTS, SKIRTS, JUMPSUITS, OVERALLS, SKORTS, DRESSES, JUMPERS, UNITARDS, LINGERIE, LEOTARDS, TIGHTS, BRAS, UNDERWEAR, SLEEPWEAR, SLEEP SHIRTS, PAJAMAS, ROBES, NIGHTGOWNS, FOOTWEAR, SHOES, BOOTS, SANDALS, SLIPPERS, SLIPPER SOCKS, SOCKS, HOSIERY, BANDANAS, NECKTIES, SCARVES, NECKERCHIEFS, MUFFLERS, CAPS AND HATS, HEADBANDS, GLOVES, BELTS, SUSPENDERS, BOXER SHORTS, SWIMSUITS INCLUDING BIKINIS AND SWIM SHORTS (U.S. CLS. 22 AND 39).

FIRST USE 11-8-2008; IN COMMERCE 11-8-2008.

3,941,479. HONG, WAN KI, SEOUL, REPUBLIC OF KOREA.  
SN 77-836,895. PUB. 8-24-2010, FILED 9-29-2009.

# HJC

THE MARK CONSISTS OF STANDARD CHARACTERS WITHOUT CLAIM TO ANY PARTICULAR FONT, STYLE, SIZE, OR COLOR.

OWNER OF U.S. REG. NOS. 3,224,785 AND 3,475,242.  
FOR CLOTHING, NAMELY, GLOVES, JACKETS, PANTS, COLD WEATHER FACE MASKS, BALACLAVAS, AND HEADLINERS, SPECIFICALLY, FABRIC COVERINGS OF THE HEAD TO BE WORN UNDERNEATH MOTORCYCLE HELMETS, SNOWMOBILE HELMETS AND PROTECTIVE HELMETS (U.S. CLS. 22 AND 39).

FIRST USE 1-1-1986; IN COMMERCE 1-1-1986.

3,941,486. LITTLE NY ENTERPRISES, INC., DBA CAPITAL KIDZWEAR, ALBANY, NY. SN 77-840,824. PUB. 6-22-2010, FILED 10-3-2009.



NO CLAIM IS MADE TO THE EXCLUSIVE RIGHT TO USE "KIDZWEAR AND THE ALBANY SKYLINE", APART FROM THE MARK AS SHOWN.

THE COLOR(S) RED,BLUE,TEAL,YELLOW AND WHITE IS/ARE CLAIMED AS A FEATURE OF THE MARK.

**CLASS 25—(Continued).**

THE MARK CONSISTS OF THE ALBANY, NY SKYLINE FORMING A BLUE BACKGROUND WITH TWO RED KID IMAGES ON EITHER SIDE. THE STYLIZED WORD "CAPITAL" APPEARS IN TEAL AND FADES TO WHITE WITH A YELLOW STAR IN THE LETTER P. THE WORD "KIDZWEAR" APPEARS UNDERNEATH IN WHITE LOWERCASE LETTERS CUT OUT OF YELLOW RECTANGLE CARRIERS.

FOR CHILDREN'S AND INFANT'S APPAREL, NAMELY, JUMPERS, OVERALL SLEEPWEAR, PAJAMAS, ROMPERS AND ONE-PIECE GARMENTS (U.S. CLS. 22 AND 39).

FIRST USE 11-1-2009; IN COMMERCE 9-17-2010.

3,941,520. WILLIAMSON-DICKIE MANUFACTURING COMPANY, FORT WORTH, TX. SN 77-858,061. PUB. 5-25-2010, FILED 10-27-2009.

FT. WORTH, TX  SINCE 1922

OWNER OF U.S. REG. NOS. 594,540, 3,063,324, AND OTHERS.

NO CLAIM IS MADE TO THE EXCLUSIVE RIGHT TO USE "FT. WORTH, TX" OR "SINCE 1922", APART FROM THE MARK AS SHOWN.

THE MARK CONSISTS OF THE STYLIZED WORDING "FT. WORTH, TX, DICKIES, SINCE 1922", AND STYLIZED LETTER "D" IN THE SHAPE OF A HORSESHOE. THE STYLIZED WORDING "DICKIES" IS IN A RECTANGULAR CARRIER OVER THE HORSESHOE DESIGN WHICH IS WITHIN AN OVAL CARRIER.

FOR MEN'S, WOMEN'S AND CHILDREN'S CLOTHING, NAMELY, PANTS, TROUSERS AND SLACKS (U.S. CLS. 22 AND 39).

FIRST USE 10-1-2010; IN COMMERCE 10-1-2010.

3,941,526. SHIELDS, ARMAN, ADELPHI, MD. SN 77-859,308. PUB. 6-15-2010, FILED 10-28-2009.

VÃO

THE MARK CONSISTS OF STANDARD CHARACTERS WITHOUT CLAIM TO ANY PARTICULAR FONT, STYLE, SIZE, OR COLOR.

FOR BELTS; HATS; JACKETS; JEANS; SHIRTS; SHOES; UNDERWEAR (U.S. CLS. 22 AND 39).

FIRST USE 3-7-2010; IN COMMERCE 3-7-2010.

**CLASS 25—(Continued).**

3,941,531. SUNBELT STEEL TEXAS, LLC, HOUSTON, TX. SN 77-863,656. PUB. 9-28-2010, FILED 11-3-2009.

 Sunbelt Steel

OWNER OF U.S. REG. NOS. 2,504,747 AND 2,515,471.

THE MARK CONSISTS OF THE WORDING "SUNBELT STEEL" AND THE DESIGN OF A PIPE ON TOP OF A SHADED CIRCLE.

FOR CLOTHING AND HEADGEAR APPAREL, NAMELY, SHIRTS, T-SHIRTS, SPORT SHIRTS, SWEATSHIRTS, POLO SHIRTS, DRESS SHIRTS, FLANNEL SHIRTS, SWEATERS, JACKETS, SHORTS, DRESS PANTS, SWEAT PANTS, DRESSES, BLOUSES, CAPS, HATS, SOCKS AND STOCKINGS, GLOVES, TIES, SCARVES, HEADBANDS, BOOTS, SHOES AND SLIPPERS (U.S. CLS. 22 AND 39).

FIRST USE 9-1-2009; IN COMMERCE 9-1-2009.

3,941,536. STEVE DAMSA, ZEPHYR HILLS, FL. SN 77-865,029. PUB. 5-11-2010, FILED 11-4-2009.

 CANCER SURVIVOR  
I Believe

THE MARK CONSISTS OF AN IMAGE OF A ROSE, WITH A FLAME ABOVE THE ROSE, BETWEEN THE WORDS "CANCER" AND "SURVIVOR" WITH THE WORDS "I BELIEVE" CENTERED BENEATH THE ROSE.

FOR CLOTHING, NAMELY, T-SHIRTS, POLO SHIRTS, SWEAT SHIRTS, HOODED SWEAT SHIRTS, TIES, AND HATS (U.S. CLS. 22 AND 39).

FIRST USE 10-8-2010; IN COMMERCE 10-8-2010.

**CLASS 25—(Continued).**

3,941,537. AMY CUBBISON, DBA LEAVE ME BE, CARLSBAD, CA. SN 77-865,241. PUB. 4-13-2010, FILED 11-4-2009.

**I'M PREGNANT WHAT IS YOUR  
EXCUSE**

THE MARK CONSISTS OF STANDARD CHARACTERS WITHOUT CLAIM TO ANY PARTICULAR FONT, STYLE, SIZE, OR COLOR.

FOR CLOTHING, NAMELY, SHIRTS, T-SHIRTS, UNDER SHIRTS, NIGHT SHIRTS, RUGBY SHIRTS, POLO SHIRTS, CARDIGANS, JERSEYS, UNIFORMS, ATHLETIC UNIFORMS, PANTS, TROUSERS, SLACKS, JEANS, DENIM JEANS, CULOTTES, CARGO PANTS, OVERALLS, COVERALLS, JUMPERS, JUMP SUITS, SHORTS, BOXER SHORTS, TOPS, CROP TOPS, TANK TOPS, HALTER TOPS, SWEAT SHIRTS, SWEAT SHORTS, SWEAT PANTS, WRAPS, WARM-UP SUITS, JOGGING SUITS, TRACK SUITS, BLOUSES, SKIRTS, DRESSES, GOWNS, SWEATERS, VESTS, FLEECE VESTS, PULLOVERS, SNOW SUITS, PARKAS, CAPES, ANORAKS, PONCHOS, JACKETS, REVERSIBLE JACKETS, COATS, BLAZERS, SUITS, TURTLENECKS, CLOTH SKI BIBS, SWIMWEAR, BEACHWEAR, TENNIS WEAR, SURF WEAR, SKI WEAR, INFANT WEAR, BABY BIBS NOT OF PAPER, CLOTH DIAPERS, CAPS, SWIM CAPS, BERETS, BEANIES, HATS, VISORS, HEADBANDS, WRIST BANDS, SWEAT BANDS, HEADWEAR, EAR MUFFS, APRONS, SCARVES, BANDANAS, BELTS, SUSPENDERS, NECKWEAR, NECKTIES, TIES, NECKERCHIEFS, ASCOTS, UNDERWEAR, BRIEFS, SWIM AND BATHING TRUNKS, BRAS, SPORTS BRAS, BRASIERES, BUSTIERS, CORSETS, PANTIES, GARTERS AND GARTER BELTS, TEDDIES, GIRDLES, FOUNDATION GARMENTS, SINGLET, SOCKS, LOUNGEWEAR, ROBES, BATHROBES, UNDERCLOTHES, PAJAMAS, SLEEPWEAR, NIGHT GOWNS, LINGERIE, CAMISOLES, NEGLIGEES, CHEMISES, CHEMISETTES, SLIPS, SARONGS, LEG WARMERS, HOSIERY, PANTYHOSE, BODY STOCKINGS, KNEE HIGHS, LEGGINGS, TIGHTS, LEOTARDS, BODY SUITS, UNITARDS, BODY SHAPERS, GLOVES, MITTENS, FOOTWEAR, SHOES, SNEAKERS, BOOTS, GALOSHES, SANDALS, FLIP-FLOPS, ZORI, SLIPPERS AND RAINWEAR (U.S. CLS. 22 AND 39).

FIRST USE 1-3-2007; IN COMMERCE 1-3-2007.

3,941,538. LEAVE ME B, CARLSBAD, CA. SN 77-865,286. PUB. 4-13-2010, FILED 11-4-2009.

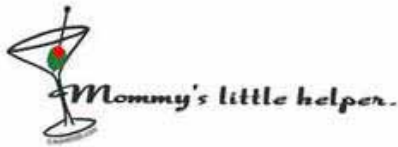

THE COLOR(S) GREEN, RED, BLACK, AND WHITE IS/ARE CLAIMED AS A FEATURE OF THE MARK.

**CLASS 25—(Continued).**

THE MARK CONSISTS OF THE WORDS "MOMMY'S LITTLE HELPER." IN A BLACK STYLIZED FONT. TO THE LEFT OF THE WORDS IS A DESIGN OF A MARTINI GLASS IN BLACK AND WHITE WITH THE GLASS CONTAINING A BLACK STICK WITH RED AND GREEN OLIVE. UNDERNEATH THE GLASS DESIGN IS THE PHRASE "LEAVEMEB.COM" IN BLACK STYLIZED FONT.

FOR CLOTHING, NAMELY, SHIRTS, T-SHIRTS, UNDER SHIRTS, NIGHT SHIRTS, RUGBY SHIRTS, POLO SHIRTS, CARDIGANS, JERSEYS, UNIFORMS, ATHLETIC UNIFORMS, PANTS, TROUSERS, SLACKS, JEANS, DENIM JEANS, CULOTTES, CARGO PANTS, OVERALLS, COVERALLS, JUMPERS, JUMP SUITS, SHORTS, BOXER SHORTS, TOPS, CROP TOPS, TANK TOPS, HALTER TOPS, SWEAT SHIRTS, SWEAT SHORTS, SWEAT PANTS, WRAPS, WARM-UP SUITS, JOGGING SUITS, TRACK SUITS, BLOUSES, SKIRTS, DRESSES, GOWNS, SWEATERS, VESTS, FLEECE VESTS, PULLOVERS, SNOW SUITS, PARKAS, CAPES, ANORAKS, PONCHOS, JACKETS, REVERSIBLE JACKETS, COATS, BLAZERS, SUITS, TURTLENECKS, CLOTH SKI BIBS, SWIMWEAR, BEACHWEAR, TENNIS WEAR, SURF WEAR, SKI WEAR, INFANT WEAR, BABY BIBS NOT OF PAPER, CLOTH DIAPERS, CAPS, SWIM CAPS, BERETS, BEANIES, HATS, VISORS, HEADBANDS, WRIST BANDS, SWEAT BANDS, HEADWEAR, EAR MUFFS, APRONS, SCARVES, BANDANAS, BELTS, SUSPENDERS, NECKWEAR, NECKTIES, TIES, NECKERCHIEFS, ASCOTS, UNDERWEAR, BRIEFS, SWIM AND BATHING TRUNKS, BRAS, SPORTS BRAS, BRASIERES, BUSTIERS, CORSETS, PANTIES, GARTERS AND GARTER BELTS, TEDDIES, GIRDLES, FOUNDATION GARMENTS, SINGLET, SOCKS, LOUNGEWEAR, ROBES, BATHROBES, UNDERCLOTHES, PAJAMAS, SLEEPWEAR, NIGHT GOWNS, LINGERIE, CAMISOLES, NEGLIGEES, CHEMISES, CHEMISETTES, SLIPS, SARONGS, LEG WARMERS, HOSIERY, PANTYHOSE, BODY STOCKINGS, KNEE HIGHS, LEGGINGS, TIGHTS, LEOTARDS, BODY SUITS, UNITARDS, BODY SHAPERS, GLOVES, MITTENS, FOOTWEAR, SHOES, SNEAKERS, BOOTS, GALOSHES, SANDALS, FLIP-FLOPS, ZORI, SLIPPERS AND RAINWEAR (U.S. CLS. 22 AND 39).

FIRST USE 1-15-2005; IN COMMERCE 1-15-2005.

3,941,551. SUN POLAR INTERNATIONAL CO., LTD., CHANGHUA COUNTY, TAIWAN. SN 77-871,065. PUB. 8-17-2010, FILED 11-12-2009.



THE MARK CONSISTS OF THE WORD "NETEX" IN UPPER CASE LETTERING, TO THE LEFT OF WHICH APPEARS A DESIGN ELEMENT CONSISTING OF AN ARCH BELOW WHICH IS A VERTICAL RECTANGLE, AT THE BOTTOM OF WHICH APPEARS A SQUARE CENTERED ABOVE AND BETWEEN TWO HORIZONTAL RECTANGLES THAT ROUGHLY FORM A STYLIZED LETTER "A".

FOR DRESSES, SOCKS, PANTYHOSE, SILK STOCKINGS, GIRDLES, GLOVES, UNDERWEAR, BRIEFS, HATS, SCARVES (U.S. CLS. 22 AND 39).

FIRST USE 7-31-2009; IN COMMERCE 7-31-2009.

**CLASS 25—(Continued).**

3,941,578. KIRBY, WILLIAM B., SMYRNA, GA. AND KIRBY, FRANKIE S., SMYRNA, GA. SN 77-878,281. PUB. 4-20-2010, FILED 11-22-2009.

# SAFEKIDD

THE MARK CONSISTS OF STANDARD CHARACTERS WITHOUT CLAIM TO ANY PARTICULAR FONT, STYLE, SIZE, OR COLOR.

FOR A-SHIRTS; ANORAKS; APRONS; ATHLETIC APPAREL, NAMELY, SHIRTS, PANTS, JACKETS, FOOTWEAR, HATS AND CAPS, ATHLETIC UNIFORMS; BANDANAS; BASEBALL CAPS; BELTS; BIB SHORTS; BICYCLE GLOVES; BLAZERS; BLOUSES; BODY SHIRTS; CAP VISORS; CAPS; CARDIGANS; CHILDREN'S AND INFANT'S APPAREL, NAMELY, JUMPERS, OVERALL SLEEPWEAR, PAJAMAS, ROMPERS AND ONE-PIECE GARMENTS; CHILDREN'S HEADWEAR; CLOGS; CLOTHING FOR WEAR IN JUDO PRACTICES; CLOTHING ITEMS, NAMELY, ADHESIVE POCKETS THAT MAY BE AFFIXED DIRECTLY TO THE BODY AS A DECORATIVE PIECE OF CLOTHING WITH UTILITY; COATS; DANCE COSTUMES; DRESSES; FOOTWEAR; FOUL WEATHER GEAR; GLOVES; GOLF CAPS; GOLF PANTS, SHIRTS AND SKIRTS; GYM PANTS; GYM SHORTS; GYM SUITS; HATS; HATS FOR INFANTS, BABIES, TODDLERS AND CHILDREN; HEAD SCARVES; HEAD WEAR; HEADBANDS; HEADWEAR; HOODED PULLOVERS; HOODED SWEAT SHIRTS; JACKETS; JEANS; JERSEYS; JOGGING OUTFITS; JUDO SUITS; JUMPERS; JUMPSUITS; LEATHER BELTS; LONG SLEEVE PULLOVERS; LONG-SLEEVED SHIRTS; MEN'S AND WOMEN'S JACKETS, COATS, TROUSERS, VESTS; NECKTIES; ONE-PIECE PLAY SUITS; PANTS; PARKAS; POLO SHIRTS; PONCHOS; PULLOVERS; RAINWEAR; SANDALS; SCARVES; SCHOOL UNIFORMS; SCRUBS NOT FOR MEDICAL PURPOSES; SHIRTS; SHIRTS AND SHORT-SLEEVED SHIRTS; SHIRTS FOR INFANTS, BABIES, TODDLERS AND CHILDREN; SHOES; SHORTS; SKI WEAR; SLEEP SHIRTS; SLEEPING GARMENTS; SLEEVELESS JERSEYS; SMOCKS; SWEAT JACKETS; SWEAT PANTS; SWEAT SHIRTS; SWEAT SHORTS; SWEAT SUITS; SWEATBANDS; SWEATERS; T-SHIRTS; TEE SHIRTS; TOBOGGAN HATS, PANTS AND CAPS; VESTS; WARM UP OUTFITS; WARM UP SUITS; WOOLLY HATS; WRIST BANDS; WRISTBANDS (U.S. CLS. 22 AND 39).  
FIRST USE 12-7-2010; IN COMMERCE 12-7-2010.

3,941,608. MOXYMAÜS INC., OTTAWA, ON, CANADA. SN 77-883,281. PUB. 5-25-2010, FILED 12-1-2009.

# MOXYMAÜS

THE MARK CONSISTS OF STANDARD CHARACTERS WITHOUT CLAIM TO ANY PARTICULAR FONT, STYLE, SIZE, OR COLOR.

**CLASS 25—(Continued).**

THE ENGLISH TRANSLATION OF "MAUS" IN THE MARK IS "MOUSE". THE WORDING "MOXY" HAS NO MEANING IN A FOREIGN LANGUAGE.

FOR CLOTHING, NAMELY, SOCKS, HOSIERY, TIGHTS, STOCKINGS, UNDERWEAR AND LINGERIE (U.S. CLS. 22 AND 39).

FIRST USE 12-31-2010; IN COMMERCE 12-31-2010.

3,941,618. HYBRID PROMOTIONS LLC, CYPRESS, CA. SN 77-886,349. PUB. 5-4-2010, FILED 12-4-2009.

# WITH A TWIST

THE MARK CONSISTS OF STANDARD CHARACTERS WITHOUT CLAIM TO ANY PARTICULAR FONT, STYLE, SIZE, OR COLOR.

FOR CLOTHING, NAMELY, SHIRTS, T-SHIRTS, SWEATSHIRTS, HOODED SWEATSHIRTS, TANK TOPS, CAMISOLES (U.S. CLS. 22 AND 39).

FIRST USE 12-17-2010; IN COMMERCE 12-17-2010.

3,941,638. FIDELITY SPORTSWEAR COMPANY, EVERETT, MA. SN 77-892,914. PUB. 6-29-2010, FILED 12-14-2009.

# GERALD & STEWART

THE MARK CONSISTS OF STANDARD CHARACTERS WITHOUT CLAIM TO ANY PARTICULAR FONT, STYLE, SIZE, OR COLOR.

FOR CLOTHING, NAMELY, JACKETS, COATS, SHIRTS AND VESTS (U.S. CLS. 22 AND 39).

FIRST USE 6-14-2010; IN COMMERCE 6-14-2010.

**CLASS 25—(Continued).**

3,941,644. CHE-WEN LIN, TAIPEI COUNTY, TAIWAN. SN 77-894,276. PUB. 5-18-2010, FILED 12-16-2009.

# Rainman

THE MARK CONSISTS OF STANDARD CHARACTERS WITHOUT CLAIM TO ANY PARTICULAR FONT, STYLE, SIZE, OR COLOR.

FOR ADULT NOVELTY GAG CLOTHING ITEM, NAMELY, SOCKS; ATHLETIC APPAREL, NAMELY, SHIRTS, PANTS, JACKETS, FOOTWEAR, HATS AND CAPS, ATHLETIC UNIFORMS; ATHLETIC SHOES; BELTS MADE OUT OF CLOTH; BOW TIES; CANVAS SHOES; CYCLING SHOES; FOOTBALL SHOES; GYM SUITS; HATS; JOGGING SUITS; LEATHER SHOES; LEISURE SHOES; MEN'S SUITS, WOMEN'S SUITS; MITTENS; MOTORCYCLE RAIN SUITS; NECKTIES; NIGHT GOWNS; RAIN SUITS; SCARFS; SHIRTS; SOCKS AND STOCKINGS; STOCKINGS; T-SHIRTS; UNDERWEAR (U.S. CLS. 22 AND 39).

FIRST USE 4-29-2010; IN COMMERCE 4-29-2010.

---

3,941,656. BODELL, SHERI, LOS ANGELES, CA. SN 77-895,037. PUB. 6-1-2010, FILED 12-16-2009.

# BODELLA

THE MARK CONSISTS OF STANDARD CHARACTERS WITHOUT CLAIM TO ANY PARTICULAR FONT, STYLE, SIZE, OR COLOR.

OWNER OF U.S. REG. NO. 2,343,105.

FOR WOMEN'S CLOTHING, NAMELY, JACKETS, PANTS, SHIRTS, TOPS, SWEATERS, COATS, AND DRESSES (U.S. CLS. 22 AND 39).

FIRST USE 1-25-2011; IN COMMERCE 1-25-2011.

**CLASS 25—(Continued).**

3,941,703. MADIZAC ENTERPRISE COMPANY LIMITED, KOWLOON, HONG KONG. SN 77-902,176. PUB. 9-28-2010, FILED 12-29-2009.

# iiJin

THE NAME(S), PORTRAIT(S), AND/OR SIGNATURE(S) SHOWN IN THE MARK IDENTIFIES A LIVING INDIVIDUAL, WHOSE CONSENT(S) TO REGISTER IS MADE OF RECORD.

THE MARK CONSISTS OF THE WORDING "IIJIN" IN STYLIZED FONT.

FOR SWIM WEAR; SWIMSUITS; SWEATERS; SHIRTS; T-SHIRTS; SKIRTS; TROUSERS; DOWN JACKETS; LEISURE SUITS; COATS; OUTER JACKETS; JACKETS; OVERCOATS; SHORTS; CLOAKS; STOLE; MANTLES; SPORTS WEAR, NAMELY, SPORTS SHIRTS, SPORTS COATS, SPORTS JERSEYS, SPORTS JACKETS, SPORTS PANTS, SPORTS OVERUNIFORMS; LEATHER CLOTHING, NAMELY, LEATHER COATS, LEATHER JACKETS, LEATHER TROUSERS; UNIFORMS; JEANS; WOMEN'S SHOES; MEN'S SHOES; SANDALS; CANVAS SHOES; LEATHER SHOES; SPORTS SHOES; LEISURE SHOES; SCARVES; SILK SCARVES; EAR MUFFS; HATS; CAPS; SILK STOCKINGS; ANKLE SOCKS; GLOVES AS CLOTHING; BELTS FOR CLOTHING; BELTS MADE OF LEATHER FOR CLOTHING (U.S. CLS. 22 AND 39).

FIRST USE 12-21-2007; IN COMMERCE 6-1-2010.

---

3,941,722. FAMILY TIME SPORTING APPAREL, LLC, AUSTIN, TX. SN 77-905,183. PUB. 5-25-2010, FILED 1-5-2010.

# COOL-EDGE FABRIC TECHNOLOGY

THE MARK CONSISTS OF STANDARD CHARACTERS WITHOUT CLAIM TO ANY PARTICULAR FONT, STYLE, SIZE, OR COLOR.

NO CLAIM IS MADE TO THE EXCLUSIVE RIGHT TO USE "FABRIC TECHNOLOGY", APART FROM THE MARK AS SHOWN.

FOR CLOTHING, NAMELY, SHORTS, PANTS, JACKETS, SWEATERS, SWEATSHIRTS, SWEAT PANTS, SWEAT SUITS, SWIM WEAR, SOCKS, SHIRTS, T-SHIRTS, HEADBANDS, WRISTBANDS, HATS AND CAPS (U.S. CLS. 22 AND 39).

FIRST USE 3-1-2008; IN COMMERCE 6-8-2009.



**CLASS 25—(Continued).**

3,941,735. RICE, CURTIS D., JR, NORTH LITTLE ROCK, AR. SN 77-908,095. PUB. 6-1-2010, FILED 1-8-2010.



THE COLOR(S) BLACK, WHITE, RED AND BLUE IS/ARE CLAIMED AS A FEATURE OF THE MARK.  
THE MARK CONSISTS OF THE WORDS "LYRICS NEVA DIE" IN WHITE OUTLINED IN BLACK WITH BLUE LINES INSIDE THE LETTERS. CURVED LINES APPEAR IN BLACK ON EITHER SIDE OF THE WORD "DIE." THE WORDING AND CURVED LINES APPEAR WITHIN A RED CIRCLE OUTLINED IN BLACK SUGGESTING A DRUM ABOVE TWO CROSSED BLACK PENCILS.  
FOR MERCHANDISE, NAMELY, T-SHIRTS, JACKETS, HATS, AND WRISTBANDS (U.S. CLS. 22 AND 39).  
FIRST USE 9-7-2010; IN COMMERCE 11-1-2010.

3,941,751. SHOWTIME NETWORKS INC, NEW YORK, NY. SN 77-911,166. PUB. 5-25-2010, FILED 1-13-2010.

**UNITED STATES OF TARA**

THE MARK CONSISTS OF STANDARD CHARACTERS WITHOUT CLAIM TO ANY PARTICULAR FONT, STYLE, SIZE, OR COLOR.  
OWNER OF U.S. REG. NO. 3,728,994.  
FOR CLOTHING, NAMELY, T-SHIRTS, SWEATSHIRTS, JACKETS, PAJAMAS, TANK TOPS, SHORTS, SWEATPANTS, HATS (U.S. CLS. 22 AND 39).  
FIRST USE 9-30-2009; IN COMMERCE 9-30-2009.

**CLASS 25—(Continued).**

3,941,760. STEVEN E. ROSEN, DAVIE, FL. SN 77-912,948. PUB. 6-1-2010, FILED 1-15-2010.

**DIKONDRA**

THE MARK CONSISTS OF STANDARD CHARACTERS WITHOUT CLAIM TO ANY PARTICULAR FONT, STYLE, SIZE, OR COLOR.  
THE WORDING "DIKONDRA" HAS NO MEANING IN A FOREIGN LANGUAGE.  
FOR RUNNING PADS THAT STRAP ONTO SHOES (U.S. CLS. 22 AND 39).  
FIRST USE 4-0-2010; IN COMMERCE 4-0-2010.

3,941,769. YIN TAO, MASON, OH. SN 77-913,760. PUB. 6-8-2010, FILED 1-18-2010.

**NEVERPANDO**

THE MARK CONSISTS OF STANDARD CHARACTERS WITHOUT CLAIM TO ANY PARTICULAR FONT, STYLE, SIZE, OR COLOR.  
THE WORDING "NEVERPANDO" HAS NO MEANING IN A FOREIGN LANGUAGE.  
FOR ATHLETIC SHOES; BEACH COVER-UPS; BEACH SHOES; BOOTS; CAPS; CLIMBING BOOTS; DOWN JACKETS; DRESSES; FOOTWEAR; GLOVES AS CLOTHING; JACKETS; KNIT SHIRTS; KNITTED CAPS; KNITTED GLOVES; KNITTED UNDERWEAR; SCARFS; SHIRTS; SHORTS; SKI BOOTS; SPORTS JERSEYS; TEE SHIRTS; TOPS; TROUSERS; WET SUITS FOR WATER-SKIING AND SUB-AQUA; WIND COATS (U.S. CLS. 22 AND 39).  
FIRST USE 9-1-2008; IN COMMERCE 5-14-2010.

**CLASS 25—(Continued).**

3,941,773. FLORIDA PANTHERS HOCKEY CLUB, LTD., SUNRISE, FL. SN 77-914,444. PUB. 6-1-2010, FILED 1-19-2010.



OWNER OF U.S. REG. NOS. 1,876,001, 2,114,376, AND OTHERS.

NO CLAIM IS MADE TO THE EXCLUSIVE RIGHT TO USE "FLORIDA", APART FROM THE MARK AS SHOWN.

THE MARK CONSISTS OF THE WORDS "FLORIDA PANTHERS" APPEARING WITHIN THE BORDER OF A CIRCLE WITH THE TERM "FLORIDA" ALONG THE TOP ARC, THE TERM "PANTHERS" ALONG THE BOTTOM ARC AND TWO SMALL DOTS SEPARATING THE TERMS. THE DESIGN OF A PANTHER HEAD APPEARS ON THE INTERIOR OF THE CIRCLE.

FOR CAPS, JERSEYS, T-SHIRTS (U.S. CLS. 22 AND 39). FIRST USE 11-23-2009; IN COMMERCE 11-23-2009.

3,941,806. ONE WORLD ACCESS, MALIBU, CA. SN 77-919,575. PUB. 6-8-2010, FILED 1-25-2010.

**PHOTOGENIQUE**

THE MARK CONSISTS OF STANDARD CHARACTERS WITHOUT CLAIM TO ANY PARTICULAR FONT, STYLE, SIZE, OR COLOR.

FOR TEE SHIRTS, SHIRTS, JACKETS, SWEATSHIRTS, SWEATERS, SOCKS, UNDERWEAR, HATS, PANTS (U.S. CLS. 22 AND 39).

FIRST USE 2-1-2011; IN COMMERCE 2-1-2011.

**CLASS 25—(Continued).**

3,941,810. LIN, JIMMY, BUENA PARK, CA. SN 77-920,128. PUB. 6-15-2010, FILED 1-26-2010.

**CUTIE UNIVERSITY**

THE MARK CONSISTS OF STANDARD CHARACTERS WITHOUT CLAIM TO ANY PARTICULAR FONT, STYLE, SIZE, OR COLOR.

FOR BEANIES; BOOTIES; HATS; JACKETS; PANTS; SHIRTS; SHORTS; SOCKS; SWEAT PANTS; SWEATERS; UNDERWEAR (U.S. CLS. 22 AND 39).

FIRST USE 6-3-2009; IN COMMERCE 12-27-2009.

3,941,811. JOMOWAG LLC, SNOQUALMIE, WA. SN 77-920,152. PUB. 6-8-2010, FILED 1-26-2010.

**FLIPWEAR**

THE MARK CONSISTS OF STANDARD CHARACTERS WITHOUT CLAIM TO ANY PARTICULAR FONT, STYLE, SIZE, OR COLOR.

FOR BEANIES; BOTTOMS; CAPS; CAPS WITH VISORS; HOODED SWEAT SHIRTS; JACKETS; POLO SHIRTS; PULLOVERS; SHIRTS; SHORTS; SPORTS PANTS; SWEAT SHIRTS; T-SHIRTS (U.S. CLS. 22 AND 39).

FIRST USE 10-15-2010; IN COMMERCE 12-1-2010.

3,941,833. KOSTERS, EDWARD A., DBA ALEX KOSTERS, LOS ANGELES, CA. SN 77-922,555. PUB. 6-15-2010, FILED 1-28-2010.

**VER SACRUM**

THE MARK CONSISTS OF STANDARD CHARACTERS WITHOUT CLAIM TO ANY PARTICULAR FONT, STYLE, SIZE, OR COLOR.

THE ENGLISH TRANSLATION OF "VER SACRUM" IN THE MARK IS "SACRED SPRING".

FOR CLOTHING, NAMELY, DRESSES, JACKETS, JEANS, SHIRTS, SOCKS, TROUSERS (U.S. CLS. 22 AND 39).

FIRST USE 1-27-2011; IN COMMERCE 1-27-2011.

**CLASS 25—(Continued).**

3,941,836. BEST, STEVEN JAMES, VACAVILLE, CA. SN 77-923,342. PUB. 6-15-2010, FILED 1-29-2010.

du Ya

THE MARK CONSISTS OF STANDARD CHARACTERS WITHOUT CLAIM TO ANY PARTICULAR FONT, STYLE, SIZE, OR COLOR.

FOR JACKETS; PANTS; SHIRTS (U.S. CLS. 22 AND 39).  
FIRST USE 1-1-2009; IN COMMERCE 2-1-2010.

3,941,846. ALDERSON, NEVA, SAN PEDRO, CA. SN 77-925,813. PUB. 8-17-2010, FILED 2-2-2010.

FRANCOIS LEON FASHIONS

THE MARK CONSISTS OF STANDARD CHARACTERS WITHOUT CLAIM TO ANY PARTICULAR FONT, STYLE, SIZE, OR COLOR.

NO CLAIM IS MADE TO THE EXCLUSIVE RIGHT TO USE "FASHIONS", APART FROM THE MARK AS SHOWN. THE NAME SHOWN IN THE MARK DOES NOT IDENTIFY A PARTICULAR LIVING INDIVIDUAL.

FOR BATHING SUITS; BELTS; CAMISOLES; CAPELETS; CAPES; CLOAKS; COATS; DRESSES; GLOVES; GOWNS; JACKETS; NIGHTGOWNS; PAJAMAS; PANTIES; PANTS; PAREOS; SCARVES; SHAWLS; SHIRTS; SHRUGS; SKIRTS; SLIPS; SOCKS; STOCKINGS; SWEATERS; UNDERWEAR; VEILS; VESTS (U.S. CLS. 22 AND 39).

FIRST USE 3-18-2010; IN COMMERCE 3-18-2010.

3,941,847. NC-02, INC., NEW YORK, NY. SN 77-925,882. PUB. 6-15-2010, FILED 2-2-2010.

WAVERLY GREY

THE MARK CONSISTS OF STANDARD CHARACTERS WITHOUT CLAIM TO ANY PARTICULAR FONT, STYLE, SIZE, OR COLOR.

THE NAME(S), PORTRAIT(S), AND/OR SIGNATURE(S) SHOWN IN THE MARK DOES NOT IDENTIFY A PARTICULAR LIVING INDIVIDUAL.

FOR BLOUSES; CARDIGANS; DRESSES; JACKETS; PANTS; SHORTS; SKIRTS; SWEATERS; VESTS (U.S. CLS. 22 AND 39).

FIRST USE 8-9-2010; IN COMMERCE 8-9-2010.

**CLASS 25—(Continued).**

3,941,857. INFUSE ATHLETICS LLC, DBA INFUSE ATHLETICS LLC, PORT SAINT LUCIE, FL. SN 77-927,470. PUB. 6-15-2010, FILED 2-3-2010.



THE MARK CONSISTS OF A CAPITAL "F" WITH AN ANGLED BOTTOM, WITH ANOTHER IDENTICAL CAPITAL "F" THAT IS MIRRORED NEXT TO IT. THEN THE WORD "INFUSE" IN BOLD CAPITAL LETTERS WITH EACH LETTER HAVING A DISTINCT ANGLED ELEMENT TO IT.

FOR ATHLETIC APPAREL, NAMELY, SHIRTS, PANTS, JACKETS, FOOTWEAR, HATS AND CAPS, ATHLETIC UNIFORMS; BASEBALL CAPS; BASEBALL UNIFORMS; BOARD SHORTS; BODY SHIRTS; BOXING SHOES; BOXING SHORTS; CAPS; CAPS WITH VISORS; DENIMS; DRESS SHIRTS; FISHING SHIRTS; FLEECE SHORTS; GLOVES; GLOVES AS CLOTHING; GOLF CAPS; GOLF CLEATS; GOLF PANTS, SHIRTS AND SKIRTS; GOLF SHIRTS; GOLF SHOES; GOLF SHORTS; GOLF SPIKES; GOLF TROUSERS; GYM PANTS; GYM SHORTS; HOODED SWEAT SHIRTS; HUNTING PANTS; HUNTING SHIRTS; JOGGING PANTS; KNIT SHIRTS; KNITTED CAPS; KNITTED GLOVES; LONG-SLEEVED SHIRTS; MOISTURE-WICKING SPORTS PANTS; MOISTURE-WICKING SPORTS SHIRTS; OPEN-NECKED SHIRTS; OUTDOOR GLOVES; OVER SHIRTS; PANTIES, SHORTS AND BRIEFS; PANTS; POLO SHIRTS; RUGBY SHIRTS; RUGBY SHORTS; SHIRTS; SHIRTS AND SHORT-SLEEVED SHIRTS; SHIRTS FOR INFANTS, BABIES, TODDLERS AND CHILDREN; SHORT-SLEEVED OR LONG-SLEEVED T-SHIRTS; SHORT-SLEEVED SHIRTS; SHORTS; SLEEP SHIRTS; SLIDING SHORTS; SPORT SHIRTS; SPORTS PANTS; SPORTS SHIRTS; SPORTS SHIRTS WITH SHORT SLEEVES; SWEAT PANTS; SWEAT SHIRTS; SWEAT SHORTS; SWIM CAPS; SWIMMING CAPS; SWIMMING CAPS; T-SHIRTS; TRIATHLON CLOTHING, NAMELY, TRIATHLON TIGHTS, TRIATHLON SHORTS, TRIATHLON SINGLETS, TRIATHLON SHIRTS, TRIATHLON SUITS; UNDERWEAR, NAMELY, BOY SHORTS; WALKING SHORTS; WATERPROOF JACKETS AND PANTS; WEARABLE GARMENTS AND CLOTHING, NAMELY, SHIRTS (U.S. CLS. 22 AND 39).

FIRST USE 3-12-2010; IN COMMERCE 3-12-2010.

**CLASS 25—(Continued).**

3,941,872. AUSTIN, TRACY, BRONX, NY. SN 77-930,282. PUB. 7-6-2010, FILED 2-8-2010.

**FOR ALL ISSUES TRUST HIM**

THE MARK CONSISTS OF STANDARD CHARACTERS WITHOUT CLAIM TO ANY PARTICULAR FONT, STYLE, SIZE, OR COLOR.

FOR HATS; JACKETS; SHIRTS; SWEATERS; VESTS (U.S. CLS. 22 AND 39).

FIRST USE 2-1-2011; IN COMMERCE 2-1-2011.

3,941,883. LORI GOLDSTEIN, NEW YORK, NY. SN 77-931,382. PUB. 6-22-2010, FILED 2-9-2010.

**INSTANT CHIC**

THE MARK CONSISTS OF STANDARD CHARACTERS WITHOUT CLAIM TO ANY PARTICULAR FONT, STYLE, SIZE, OR COLOR.

FOR APPAREL, NAMELY, SWEATERS, PANTS, JACKETS, COATS, SCARVES, T-SHIRTS, DRESSES, SKIRTS, TOPS, HEADWEAR AND FOOTWEAR (U.S. CLS. 22 AND 39).

FIRST USE 1-0-2010; IN COMMERCE 1-0-2010.

3,941,886. KIM, JAE, TOTOWA, NJ. SN 77-931,633. PUB. 6-22-2010, FILED 2-9-2010.

**RAREFIED**

THE MARK CONSISTS OF STANDARD CHARACTERS WITHOUT CLAIM TO ANY PARTICULAR FONT, STYLE, SIZE, OR COLOR.

FOR BOTTOMS, COATS, JACKETS, JEANS, PANTS, SHIRTS, SHORTS, SWEATERS, TOPS (U.S. CLS. 22 AND 39).

FIRST USE 3-1-2010; IN COMMERCE 3-1-2010.

**CLASS 25—(Continued).**

3,941,920. LANKOVA, KATERINA, NEW YORK, NY. SN 77-941,554. PUB. 7-20-2010, FILED 2-22-2010.

**STEE-LETAS**

THE MARK CONSISTS OF STANDARD CHARACTERS WITHOUT CLAIM TO ANY PARTICULAR FONT, STYLE, SIZE, OR COLOR.

FOR CLOTHING, NAMELY, LEGGINGS, LEG WARMERS, STIRRUP LEG WARMERS, LEG WARMER TIGHTS (U.S. CLS. 22 AND 39).

FIRST USE 3-0-2010; IN COMMERCE 3-0-2010.

3,941,936. MIZUNO CORPORATION, OSAKA, 541-8538, JAPAN. SN 77-945,582. PUB. 8-3-2010, FILED 2-26-2010.

**MIZUNO QUICK DRY PLUS**

THE MARK CONSISTS OF STANDARD CHARACTERS WITHOUT CLAIM TO ANY PARTICULAR FONT, STYLE, SIZE, OR COLOR.

OWNER OF U.S. REG. NOS. 1,755,313, 2,163,515, AND OTHERS.

NO CLAIM IS MADE TO THE EXCLUSIVE RIGHT TO USE "QUICK DRY", APART FROM THE MARK AS SHOWN.

FOR CLOTHING, NAMELY, SPORTING WEAR, NAMELY, SOCKS, SHIRTS, LONG SLEEVE SHIRTS, SHORT SLEEVE SHIRTS, T-SHIRTS, SLEEVELESS SHIRTS, TIGHTS, PANTS, CAPS, WRISTBANDS AND SHORTS, CASUAL WEAR, NAMELY, UNDERWEAR (U.S. CLS. 22 AND 39).

FIRST USE 2-1-2010; IN COMMERCE 2-1-2010.

3,941,937. HBI BRANDED APPAREL ENTERPRISES, LLC, WINSTON-SALEM, NC. SN 77-945,597. PUB. 7-20-2010, FILED 2-26-2010.

**ONE SMOOTH U**

THE MARK CONSISTS OF STANDARD CHARACTERS WITHOUT CLAIM TO ANY PARTICULAR FONT, STYLE, SIZE, OR COLOR.

FOR BRAS (U.S. CLS. 22 AND 39).

FIRST USE 11-15-2010; IN COMMERCE 11-15-2010.

**CLASS 25—(Continued).**

3,941,953. CDC APPAREL, INC., LOS ANGELES, CA. SN 77-951,796. PUB. 7-27-2010, FILED 3-5-2010.

love, coco

THE MARK CONSISTS OF STANDARD CHARACTERS WITHOUT CLAIM TO ANY PARTICULAR FONT, STYLE, SIZE, OR COLOR.

FOR CLOTHING, NAMELY, TOPS, T-SHIRTS, TUNICS, BLOUSES, SHORTS, PANTS, DRESSES, JACKETS AND JUMPERS FOR GIRLS, JUNIORS AND WOMEN (U.S. CLS. 22 AND 39).

FIRST USE 9-30-2010; IN COMMERCE 10-30-2010.



3,942,022. FRANKEL DESIGN INC., WOODLAND HILLS, CA. SN 77-981,238. PUB. 5-26-2009, FILED 11-18-2008.

M2F

THE MARK CONSISTS OF STANDARD CHARACTERS WITHOUT CLAIM TO ANY PARTICULAR FONT, STYLE, SIZE, OR COLOR.

FOR CLOTHING, NAMELY, SHORTS, SLACKS, TROUSERS (U.S. CLS. 22 AND 39).

FIRST USE 4-0-2010; IN COMMERCE 4-0-2010.



3,942,046. AMMEEN PROPERTIES, LLC, NEW YORK, NY. SN 77-981,466. PUB. 6-1-2010, FILED 1-27-2010.

KROON

THE MARK CONSISTS OF STANDARD CHARACTERS WITHOUT CLAIM TO ANY PARTICULAR FONT, STYLE, SIZE, OR COLOR.

OWNER OF U.S. REG. NOS. 3,694,144, 3,765,432, AND OTHERS.

FOR SHIRTS (U.S. CLS. 22 AND 39).  
FIRST USE 9-17-2010; IN COMMERCE 9-17-2010.

**CLASS 25—(Continued).**

3,942,097. FOWLER, VANESSA N., HONOLULU, HI. AND FOWLER, MAX R., HONOLULU, HI. SN 85-008,861. PUB. 8-31-2010, FILED 4-7-2010.

Life is swell

THE MARK CONSISTS OF STANDARD CHARACTERS WITHOUT CLAIM TO ANY PARTICULAR FONT, STYLE, SIZE, OR COLOR.

FOR BASEBALL CAPS AND HATS; BOARD SHORTS; HATS; HATS FOR INFANTS, BABIES, TODDLERS AND CHILDREN; HOODED SWEAT SHIRTS; INFANT AND TODDLER ONE PIECE CLOTHING; LONG-SLEEVED SHIRTS; SHIRTS AND SHORT-SLEEVED SHIRTS; SHIRTS FOR INFANTS, BABIES, TODDLERS AND CHILDREN; SHORT-SLEEVED OR LONG-SLEEVED T-SHIRTS; SURF WEAR; T-SHIRTS; WEARABLE GARMENTS AND CLOTHING, NAMELY, SHIRTS (U.S. CLS. 22 AND 39).

FIRST USE 6-1-2010; IN COMMERCE 7-15-2010.



3,942,101. AVA DESIGN LLC, NEW YORK, NY. SN 85-012,111. PUB. 9-7-2010, FILED 4-12-2010.

MADISON HILL

THE MARK CONSISTS OF STANDARD CHARACTERS WITHOUT CLAIM TO ANY PARTICULAR FONT, STYLE, SIZE, OR COLOR.

FOR SHIRTS, PANTS, SWEATERS, DRESSES, SKIRTS (U.S. CLS. 22 AND 39).

FIRST USE 12-0-2008; IN COMMERCE 12-0-2008.



3,942,102. AVA DESIGN LLC, NEW YORK, NY. SN 85-012,114. PUB. 9-7-2010, FILED 4-12-2010.

600 WEST

THE MARK CONSISTS OF STANDARD CHARACTERS WITHOUT CLAIM TO ANY PARTICULAR FONT, STYLE, SIZE, OR COLOR.

FOR SHIRTS, PANTS, SWEATERS, DRESSES, SKIRTS (U.S. CLS. 22 AND 39).

FIRST USE 7-0-2002; IN COMMERCE 7-0-2002.

**CLASS 25—(Continued).**

3,942,138. JAMALL ADAMS, QUEENS, NY. SN 85-027,860.  
PUB. 10-5-2010, FILED 4-30-2010.

**PORK KNOCKERS**

THE MARK CONSISTS OF STANDARD CHARACTERS WITHOUT CLAIM TO ANY PARTICULAR FONT, STYLE, SIZE, OR COLOR.  
FOR POLO SHIRTS; T-SHIRTS (U.S. CLS. 22 AND 39).  
FIRST USE 8-1-2010; IN COMMERCE 8-1-2010.

3,942,174. GARDNER LANDRY COMMUNICATIONS LP,  
HOUSTON, TX. SN 85-044,348. PUB. 10-19-2010, FILED 5-20-2010.

**Gardner Landry**

THE MARK CONSISTS OF STANDARD CHARACTERS WITHOUT CLAIM TO ANY PARTICULAR FONT, STYLE, SIZE, OR COLOR.  
FOR CLOTHING, NAMELY, SHIRTS (U.S. CLS. 22 AND 39).  
FIRST USE 6-0-2010; IN COMMERCE 6-0-2010.

3,942,175. GARDNER LANDRY COMMUNICATIONS LP,  
HOUSTON, TX. SN 85-044,379. PUB. 10-19-2010, FILED 5-20-2010.

**Sessanta**

THE MARK CONSISTS OF STANDARD CHARACTERS WITHOUT CLAIM TO ANY PARTICULAR FONT, STYLE, SIZE, OR COLOR.

THE ENGLISH TRANSLATION OF "SESSANTA" IN THE MARK IS SIXTY.

FOR CLOTHING, NAMELY, SHIRTS (U.S. CLS. 22 AND 39).

FIRST USE 6-0-2010; IN COMMERCE 6-0-2010.

**CLASS 25—(Continued).**

3,942,205. CONSTANTIN DARZENTA, SANDWICH, MA. SN 85-051,223. PUB. 11-23-2010, FILED 5-31-2010.



STIPPLING IS NOT A FEATURE OF THE MARK.  
THE MARK CONSISTS OF THE LETTER "A" WITHIN THE LETTER "D".

FOR CLOTHING FOR ATHLETIC USE, NAMELY, PADDED ELBOW COMPRESSION SLEEVES BEING PART OF AN ATHLETIC GARMENT; CLOTHING FOR ATHLETIC USE, NAMELY, PADDED PANTS; CLOTHING FOR ATHLETIC USE, NAMELY, PADDED SHIRTS; CLOTHING FOR ATHLETIC USE, NAMELY, PADDED SHORTS; FOOTWEAR FOR MEN AND WOMEN; FOOTWEAR FOR WOMEN; JERSEYS; MEN'S AND WOMEN'S JACKETS, COATS, TROUSERS, VESTS; PERSPIRATION ABSORBENT UNDERWEAR CLOTHING; TOPS; TRIATHLON CLOTHING, NAMELY, TRIATHLON TIGHTS, TRIATHLON SHORTS, TRIATHLON SINGLETS, TRIATHLON SHIRTS, TRIATHLON SUITS (U.S. CLS. 22 AND 39).

FIRST USE 9-1-2010; IN COMMERCE 10-1-2010.

3,942,210. MORGAN MILLER, INC., DANIA BEACH, FL. SN 85-051,959. PUB. 11-16-2010, FILED 6-1-2010.



OWNER OF U.S. REG. NO. 3,309,588.  
THE NAME "MORGAN MILLER" IDENTIFIES A LIVING INDIVIDUAL WHOSE CONSENT IS OF RECORD.

THE MARK CONSISTS OF "MM MORGAN MILLER THE QUEEN OF SOLE" IN STYLIZED FORM WITH A DESIGN COMPRISING THREE OVALS AND A STYLIZED FLOWER ABOVE THE LETTERS "MM".

FOR WOMEN'S CUSTOM MADE SHOES (U.S. CLS. 22 AND 39).

FIRST USE 12-1-2006; IN COMMERCE 12-1-2006.

**CLASS 25—(Continued).**

3,942,213. VODA FASHION LLC, DBA VODA SWIM, LOS ANGELES, CA. SN 85-053,381. PUB. 11-2-2010, FILED 6-3-2010.

# Voda

THE MARK CONSISTS OF STANDARD CHARACTERS WITHOUT CLAIM TO ANY PARTICULAR FONT, STYLE, SIZE, OR COLOR.

OWNER OF U.S. REG. NO. 3,811,826.

THE ENGLISH TRANSLATION OF "VODA" IN THE MARK IS "WATER".

FOR ADHESIVE BRAS; APPAREL FOR DANCERS, NAMELY, TEE SHIRTS, SWEATSHIRTS, PANTS, LEGGINGS, SHORTS AND JACKETS; ATHLETIC APPAREL, NAMELY, SHIRTS, PANTS, JACKETS, FOOTWEAR, HATS AND CAPS, ATHLETIC UNIFORMS; ATHLETIC FOOTWEAR; ATHLETIC SHOES; BANDANAS; BASEBALL CAPS; BATHING CAPS; BATHING COSTUMES; BATHING COSTUMES FOR WOMEN; BATHING SUITS; BATHING SUITS FOR MEN; BATHING TRUNKS; BATHROBES; BEACH COVER-UPS; BEACH COVERUPS; BEACH FOOTWEAR; BEACH SHOES; BEACHWEAR; BEANIES; BELTS; BELTS FOR CLOTHING; BELTS MADE FROM IMITATION LEATHER; BELTS MADE OF LEATHER; BELTS MADE OUT OF CLOTH; BELTS OF TEXTILE; BERETS; BERMUDA SHORTS; BIKINIS; BLAZERS; BLOUSES; BLOUSONS; BOARD SHORTS; BODICES; BODY LINEN; BODY SHAPERS; BODY SHIRTS; BODY STOCKINGS; BODY SUITS; BOMBER JACKETS; BOOTIES; BOOTS; BOTTOMS; BOW TIES; BRALETTES; BRAS; BRASSIERES; BREECHES; BRIDESMAID DRESSES; BUSTIERS; BUTTON-FRONT ALOHA SHIRTS; CAFTANS; CAMISOLES; CAPRI PANTS; CAPRIS; CAPS; CAPS WITH VISORS; CARDIGANS; CARGO PANTS; CHILDREN'S AND INFANT'S APPAREL, NAMELY, JUMPERS, OVERALL SLEEPWEAR, PAJAMAS, ROMPERS AND ONE-PIECE GARMENTS; CHILDREN'S HEADWEAR; CLOTHING, NAMELY, KHAKIS; CLOTHING, NAMELY, WRAP-AROUNDS; COATS; COATS FOR MEN AND WOMEN; COATS MADE OF COTTON; COATS OF DENIM; COMBINATIONS; CORSETS; COVERALLS; COVERUPS; CREW NECK SWEATERS; CREW NECKS; CROP TOPS; DANCE COSTUMES; DENIM JACKETS; DENIMS; DICKIES; DOWN JACKETS; DRESS SHIRTS; DRESS SUITS; DRESSES; DRESSES MADE FROM SKINS; DRESSES THAT MAY ALSO BE USED AS TOWELS; DRESSING GOWNS; DRESSING GOWNS AND BATH ROBES; DRY SUITS; EAR BANDS; EARBANDS; EVENING DRESSES; EVENING GOWNS; EYESHADES; FABRIC BELTS; FINISHED TEXTILE LININGS FOR GARMENTS; FITTED SWIMMING COSTUMES WITH BRA CUPS; FLEECE PULLOVERS; FLEECE SHORTS; FLEECE VESTS; FLIP FLOPS; FOOTWEAR; FOOTWEAR; FOOTWEAR FOR MEN; FOOTWEAR FOR MEN AND WOMEN; FOOTWEAR FOR WOMEN; FOOTWEAR MADE OF WOOD; FOOTWEAR NOT FOR SPORTS; FOOTWEAR, NAMELY, PUMPS; FOOTWEAR, NAMELY, RUBBERS; FOUNDATION GARMENTS; FOUNDATION GARMENTS WORN AROUND THE MIDSECTION OR THIGHS TO KEEP THE STOMACH IN AND CREATE A SLIMMING EFFECT; FUR CLOAKS; FUR COATS; FUR COATS AND JACKETS; FUR HATS; FUR JACKETS; FUR MUFFS; FUR STOLAS; G-STRINGS; GARTER BELTS; GIRDLES; GLOVES AS CLOTHING; GLOVES FOR APPAREL; GLOVES INCLUDING THOSE MADE OF SKIN, HIDE OR FUR; GOWNS; GYM BOOTS; GYM PANTS; GYM SHORTS; GYM SUITS; HALTER TOPS; HAT BANDS; HATS; HEAD SCARVES; HEAD SWEATBANDS; HEAD WEAR; HEADBANDS; HEADBANDS AGAINST SWEATING; HEADBANDS FOR CLOTHING; HEADWEAR; HEAVY COATS; HEAVY JACKETS; HEELS; HOODED PULLOVERS; HOODED SWEAT SHIRTS; HOODS; HOODS; HOSIERY; HOUSECOATS; INFANT AND TODDLER ONE PIECE CLOTHING; JACKET LINERS; JACKETS; JACKETS AND SOCKS; JAPANESE SLEEPING

**CLASS 25—(Continued).**

ROBES (NEMAKI); JAPANESE STYLE CLOGS AND SANDALS; JAPANESE STYLE SANDALS (ZORI); JAPANESE STYLE SANDALS OF FELT; JAPANESE STYLE SANDALS OF LEATHER; JAPANESE TOE-STRAP SANDALS (ASAURA-ZORI); JEANS; JERSEYS; JOGGING OUTFITS; JOGGING PANTS; JOGGING SUITS; JUMPERS; JUMPSUITS; KAFTANS; KNEE HIGHS; KNEE-HIGH STOCKINGS; KNICKERS; KNIT JACKETS; KNIT SHIRTS; KNITTED CAPS; KNITTED GLOVES; KNITTED UNDERWEAR; LADIES' BOOTS; LADIES' SUITS; LADIES' UNDERWEAR; LEATHER BELTS; LEATHER COATS; LEATHER HATS; LEATHER HEADWEAR; LEATHER JACKETS; LEATHER PANTS; LEATHER SHIRTS; LEATHER SHOES; LEATHER SKIRTS; LEATHER SLIPPERS; LEATHER VESTS; LEG SHAPERS; LEGGINGS; LEISURE SHOES; LEISURE SUITS; LEOTARDS; LEOTARDS AND TIGHTS FOR WOMEN, MEN AND CHILDREN OF NYLON, COTTON OR OTHER TEXTILE FIBERS; LINGERIE; LINGERIE ACCESSORIES, NAMELY, REMOVABLE SILICONE BREAST ENHANCER PADS USED IN A BRA; LOAFERS; LONG JOHN; LONG SLEEVE PULLOVERS; LONG SLEEVED VESTS; LONG UNDERWEAR; LONG-SLEEVED SHIRTS; LOUNGE PANTS; LOUNGEWEAR; MANTILLAS; MATERNITY BRAS; MATERNITY LEGGINGS, NAMELY, LEGGINGS FEATURING BUILT-IN MATERNITY BANDS; MATERNITY LINGERIE; MATERNITY SLEEPWEAR; MEN'S AND WOMEN'S JACKETS, COATS, TROUSERS, VESTS; MEN'S SUITS; MEN'S SUITS, WOMEN'S SUITS; MEN'S UNDERWEAR; MINISKIRTS; MOCCASINS; MOISTURE-WICKING SPORTS BRAS; MOISTURE-WICKING SPORTS PANTS; MOISTURE-WICKING SPORTS SHIRTS; NECKTIES; NECKWEAR; NIGHT GOWNS; NIGHT SHIRTS; NIGHTCAPS; NIGHTDRESSES; NIGHTGOWNS; NIGHTIES; NIGHTSHIRTS; NIGHTWEAR; NIPPLE COVERS, NAMELY, PASTIES; ONE-PIECE PLAY SUITS; OUTER JACKETS; OVER COATS; OVER SHIRTS; OVER-TROUSERS; OVERALLS; OVERCOATS; OVERSHOES; PADDED JACKETS; PADDING JACKETS; PAJAMA BOTTOMS; PAJAMAS; PANTALOONS; PANTIES; PANTIES, SHORTS AND BRIEFS; PANTS; PANTSUITS; PANTYHOSE; PAREOS; PAREU; PAREUS; PARTS OF CLOTHING, NAMELY, GUSSETS FOR TIGHTS, GUSSETS FOR STOCKINGS, GUSSETS FOR BATHING SUITS, GUSSETS FOR UNDERWEAR, GUSSETS FOR LEOTARDS AND GUSSETS FOR FOOTLETS; PULLOVERS; PUMPS; PYJAMAS; QUILTED VESTS; RAIN SUITS; RAIN TROUSERS; RAINCOATS; RAINPROOF JACKETS; RAINWEAR; REVERSIBLE JACKETS; ROBES; ROMPERS; RUNNING SHOES; SANDAL-CLOGS; SANDALS; SANDALS AND BEACH SHOES; SARIS; SARONGS; SASH BANDS FOR KIMONO (OBI); SASHES; SCARFS; SCARVES; SHAWLS; SHAWLS AND HEAD SCARVES; SHAWLS AND STOLAS; SHIRT FRONTS; SHIRT YOKES; SHIRTS; SHIRTS AND SHORT-SLEEVED SHIRTS; SHIRTS FOR INFANTS, BABIES, TODDLERS AND CHILDREN; SHIRTS FOR SUITS; SHOES; SHORT SETS; SHORT TROUSERS; SHORT-SLEEVED OR LONG-SLEEVED T-SHIRTS; SHORT-SLEEVED SHIRTS; SHORTS; SHOULDER SCARVES; SHOULDER WRAPS; SHOULDER WRAPS FOR CLOTHING; SILK SCARVES; SKIRTS; SKIRTS AND DRESSES; SLACKS; SLEEPING GARMENTS; SLEEPWEAR; SLEEVED OR SLEEVELESS JACKETS; SLEEVELESS JERSEYS; SLIPPERS; SOCKS AND STOCKINGS; SPORTS BRA; SPORTS BRAS; SPORTS JACKETS; SPORTS JERSEYS; SPORTS JERSEYS AND BREECHES FOR SPORTS; SPORTS OVER UNIFORMS; SPORTS PANTS; SPORTS SHIRTS; SPORTS SHIRTS WITH SHORT SLEEVES; SPORTS VESTS; STOCKINGS; STRAPLESS BRAS; STRAPS FOR BRAS; STRETCH PANTS; SUEDE JACKETS; SUIT COATS; SUITS; SUITS OF LEATHER; SUN VISORS; SUNDRESSES; SUNSUITS; SURF WEAR; SWADDLING CLOTHES; SWEAT JACKETS; SWEAT PANTS; SWEAT SHIRTS; SWEAT SUITS; SWEATERS; SWIM CAPS; SWIM TRUNKS; SWIM WEAR; SWIM WEAR FOR GENTLEMEN AND LADIES; SWIMMING COSTUMES; SWIMMING TRUNKS; SWIMSUITS; SWIMWEAR; T-SHIRTS; TANK TOPS; TANK-TOPS; TANKINIS; TENNIS DRESSES; THONGS; THONGS; TIES; TIGHTS; TOPS; TRACK JACKETS; TRACK PANTS; TRACK SUITS; TRACKSUITS; TRAINING SHOES; TRAINING SUITS; TRAVEL CLOTHING CONTAINED IN A PACKAGE COMPRISING REVERSIBLE JACKETS, PANTS, SKIRTS, TOPS AND A BELT OR SCARF; TRENCH COATS; TROUSERS; TROUSERS OF LEATHER; TRUNKS; TUBE TOPS; TUNICS; TURBANS;

**CLASS 25—(Continued).**

TURTLE NECK SHIRTS; TURTLENECK PULLOVERS; TURTLENECK SWEATERS; TURTLENECKS; TUXEDO BELTS; TUXEDOS; TWIN SETS; UNDER GARMENTS; UNDERCLOTHES; UNDERGARMENT ACCESSORIES, NAMELY, REMOVABLE SILICONE BUTTOCK ENHANCER PADS; UNDERGARMENTS; UNDERPANTS; UNDERSHIRTS; UNDERSKIRTS; UNDERWEAR; UNDERWEAR, NAMELY, BOY SHORTS; V-NECK SWEATERS; VEILS; VESTS; VISORS; WAIST BANDS; WAIST BELTS; WAISTBANDS; WAISTCOATS; WALKING SHORTS; WARM UP OUTFITS; WARM UP SUITS; WATERPROOF FOOTWEAR; WATERPROOF JACKETS AND PANTS; WATERPROOF LEATHER BOOTS; WATERPROOF LEATHER SHOES; WATERPROOF LEATHER SHOES AND BOOTS; WEARABLE GARMENTS AND CLOTHING, NAMELY, SHIRTS; WEDDING DRESSES; WEDDING GOWNS; WET SUIT GLOVES; WET SUITS; WET SUITS FOR WATER-SKIING AND SUB-AQUA; WETSUITS; WETSUITS FOR WATER-SKIING; WIND COATS; WIND PANTS; WIND SHIRTS; WIND-JACKETS; WOMEN'S CEREMONIAL DRESSES; WOMEN'S HATS AND HOODS; WOMEN'S SHOES; WOMEN'S TOPS, NAMELY, CAMIS; WOMEN'S UNDERWEAR; WRAP BELTS FOR KIMONOS (DATEMAKI); WRAPS; YOGA PANTS; YOGA SHIRTS (U.S. CLS. 22 AND 39).

FIRST USE 6-5-2010; IN COMMERCE 10-30-2010.

3,942,215. WESTPOINT INTERNATIONAL HATS, SAN FRANCISCO DEL RINCON, GTO, MEXICO. SN 85-053,738. PUB. 11-9-2010, FILED 6-3-2010.

**Cuernos Chuecos**

THE MARK CONSISTS OF STANDARD CHARACTERS WITHOUT CLAIM TO ANY PARTICULAR FONT, STYLE, SIZE, OR COLOR.

THE ENGLISH TRANSLATION OF "CUERNOS CHUECOS" IN THE MARK IS "BENT HORNS".

FOR BOOTS; HATS (U.S. CLS. 22 AND 39).  
FIRST USE 1-1-2006; IN COMMERCE 1-1-2006.

3,942,235. MAMIYE BROTHERS, INC., NEW YORK, NY. SN 85-058,612. PUB. 10-5-2010, FILED 6-9-2010.

**FOOTIE AND FRIEND**

THE MARK CONSISTS OF STANDARD CHARACTERS WITHOUT CLAIM TO ANY PARTICULAR FONT, STYLE, SIZE, OR COLOR.

NO CLAIM IS MADE TO THE EXCLUSIVE RIGHT TO USE "FOOTIE", APART FROM THE MARK AS SHOWN.

FOR CHILDREN'S CLOTHING, NAMELY, CREEPERS, COVERALLS AND ROMPERS (U.S. CLS. 22 AND 39).  
FIRST USE 9-0-2010; IN COMMERCE 9-0-2010.

**CLASS 25—(Continued).**

3,942,306. SECURITY SOURCING INTERNATIONAL, INC., LOS ANGELES, CA. SN 85-084,849. PUB. 11-2-2010, FILED 7-14-2010.

**FIELD SCOUT**

THE MARK CONSISTS OF STANDARD CHARACTERS WITHOUT CLAIM TO ANY PARTICULAR FONT, STYLE, SIZE, OR COLOR.

FOR CLOTHING, NAMELY, TOPS, SHIRTS, T-SHIRTS, SWEATSHIRTS, DRESS SHIRTS, TANK TOPS, SWEATERS, VESTS, JACKETS, COATS, BOTTOMS, PANTS, SHORTS, DRESSES, SKIRTS, SOCKS, UNDERGARMENTS, SLEEPWEAR, SUITS, FOOTWEAR, GLOVES AND HATS (U.S. CLS. 22 AND 39).

FIRST USE 10-0-2010; IN COMMERCE 10-0-2010.

3,942,313. CROCS, INC., NIWOT, CO. SN 85-093,712. PUB. 10-26-2010, FILED 7-27-2010.

**CROCS LITTLES**

THE MARK CONSISTS OF STANDARD CHARACTERS WITHOUT CLAIM TO ANY PARTICULAR FONT, STYLE, SIZE, OR COLOR.

OWNER OF U.S. REG. NOS. 3,432,489, 3,441,707, AND OTHERS.

FOR FOOTWEAR (U.S. CLS. 22 AND 39).  
FIRST USE 11-5-2010; IN COMMERCE 11-5-2010.

**CLASS 26—FANCY GOODS**

3,941,048. J. & P. COATS, LIMITED, GLASGOW G2 5PA, SCOTLAND. SN 77-296,175. PUB. 4-15-2008, FILED 10-4-2007.

**VELOCITY**

THE MARK CONSISTS OF STANDARD CHARACTERS WITHOUT CLAIM TO ANY PARTICULAR FONT, STYLE, SIZE, OR COLOR.

FOR KNITTING NEEDLES (U.S. CLS. 37, 39, 40, 42 AND 50).  
FIRST USE 4-2-2008; IN COMMERCE 4-2-2008.



**CLASS 26—(Continued).**

3,941,462. NEETAN MANDALIA, ALAMOGORDO, NM. SN 77-827,701. PUB. 8-10-2010, FILED 9-16-2009.

# HEMLOCK

THE MARK CONSISTS OF STANDARD CHARACTERS WITHOUT CLAIM TO ANY PARTICULAR FONT, STYLE, SIZE, OR COLOR.

FOR SHOE ACCESSORIES, NAMELY, SHOE LACES, SHOE EYELETS, SHOE BUCKLES, AND ORNAMENTAL SHOE CLIPS THAT ATTACH TO THE HEEL OF THE SHOE (U.S. CLS. 37, 39, 40, 42 AND 50).

FIRST USE 9-16-2009; IN COMMERCE 8-17-2010.

3,941,954. CIRILLO, MAUREEN ELIZABETH, DBA EVELYN JANICE DESIGNS, WINTHROP, MA. SN 77-952,125. PUB. 10-19-2010, FILED 3-5-2010.

# Candi Hairlites

THE MARK CONSISTS OF STANDARD CHARACTERS WITHOUT CLAIM TO ANY PARTICULAR FONT, STYLE, SIZE, OR COLOR.

NO CLAIM IS MADE TO THE EXCLUSIVE RIGHT TO USE "HAIR LIGHTS", APART FROM THE MARK AS SHOWN.

FOR ORNAMENTS FOR THE HAIR; HAIR ACCESSORIES, NAMELY, SNAP CLIPS; HAIR EXTENSIONS (U.S. CLS. 37, 39, 40, 42 AND 50).

FIRST USE 1-1-2011; IN COMMERCE 1-1-2011.

3,942,088. MCNALLY, BRENDA, WAKEFIELD, RI. SN 85-005,203. PUB. 11-9-2010, FILED 4-2-2010.



THE MARK CONSISTS OF THE STYLIZED TEXT "TWISTIK" WITH A BALL DOTTING THE FIRST "I", WITH ANOTHER BALL BELOW AND TO THE LEFT OF THE "W", UNDER THE "T", WITH A LINE CONNECTING BOTH BALLS, AND A STRAND OF HAIR RUNNING FROM LEFT TO RIGHT IN THE LOWER PART OF THE FONT.

FOR NON-ELECTRIC HAIR STYLING INSTRUMENT IN THE NATURE OF HAIR ORNAMENT THAT IS ATTACHED TO A METAL ROD USED FOR STYLING OR SETTING HAIR (U.S. CLS. 37, 39, 40, 42 AND 50).

FIRST USE 12-5-2010; IN COMMERCE 12-5-2010.

**CLASS 26—(Continued).**

3,942,206. BRUNER, ERWIN SANTOS, ROYAL PALM BEACH, FL. SN 85-051,405. PUB. 11-9-2010, FILED 6-1-2010.

# bondbers.com

THE MARK CONSISTS OF STYLIZED LETTERS SPELLING THE WORDS "BONDBERS.COM": WHERE THE STYLIZED "D", ADJACENT TO THE STYLIZED LETTER "B", HAS THE LOOP FEATURE OF THE HOOK AND LOOP APPARATUS ON THE EXTERIOR SURFACE FACING THE STYLIZED LETTER "B", AND THE ADJACENT STYLIZED LETTER "B" HAS THE HOOK FEATURE OF THE HOOK AND LOOP APPARATUS ON THE EXTERIOR SURFACE FACING THE STYLIZED LETTER "D", AND FOR HALF THE HEIGHT OF THESE TWO LETTERS THE HOOK AND LOOP FEATURES ARE ENGAGED STARTING AT THE BOTTOM AND DISENGAGES ABOUT HALF THE HEIGHT OF THESE TWO LETTERS DUE TO THE DESIGN AND CURVATURE OF THE STYLIZED LETTERS "D" AND "B".

FOR HOOK AND LOOP FASTENERS FOR USE IN THE MANUFACTURE OF BAGS MADE OF LEATHER OR FABRIC; HOOK AND LOOP FASTENERS FOR USE IN THE MANUFACTURE OF CLOTHING AND SHOES; HOOK AND LOOP FASTENING TAPE (U.S. CLS. 37, 39, 40, 42 AND 50).

FIRST USE 1-6-2011; IN COMMERCE 1-6-2011.

**CLASS 27—FLOOR COVERINGS**

3,941,561. MOHAWK CARPET DISTRIBUTION, INC., CALHOUN, GA. SN 77-872,337. PUB. 4-20-2010, FILED 11-13-2009.

# FASHION COORDINATES

THE MARK CONSISTS OF STANDARD CHARACTERS WITHOUT CLAIM TO ANY PARTICULAR FONT, STYLE, SIZE, OR COLOR.

OWNER OF U.S. REG. NOS. 2,717,602 AND 2,802,806. FOR CARPETING (U.S. CLS. 19, 20, 37, 42 AND 50).

FIRST USE 1-12-2010; IN COMMERCE 1-12-2010.

3,941,575. MOHAWK CARPET DISTRIBUTION, INC., CALHOUN, GA. SN 77-877,425. PUB. 4-20-2010, FILED 11-20-2009.

# GREEN BY DESIGN

THE MARK CONSISTS OF STANDARD CHARACTERS WITHOUT CLAIM TO ANY PARTICULAR FONT, STYLE, SIZE, OR COLOR.

**CLASS 27—(Continued).**

NO CLAIM IS MADE TO THE EXCLUSIVE RIGHT TO USE "GREEN", APART FROM THE MARK AS SHOWN.  
FOR CARPETING (U.S. CLS. 19, 20, 37, 42 AND 50).  
FIRST USE 1-12-2010; IN COMMERCE 1-12-2010.

**CLASS 28—TOYS AND SPORTING GOODS**

3,941,072. VASEN INTERNATIONAL LTD, KWUN TONG, KOWLOON, HONG KONG. SN 77-427,492. PUB. 6-1-2010, FILED 3-20-2008.



THE MARK CONSISTS OF THE STYLIZED WORD "BODY+", A SMALLER TRIANGLE DESIGN ABOVE THE LETTERS "OD" AND A LARGER TRIANGLE DESIGN BELOW THE LETTERS "BODY".

FOR EXERCISE EQUIPMENT, NAMELY, WEIGHT LIFTING MACHINES, ELLIPTICAL STRIDER; EXERCISE MACHINES, NAMELY, GYM STATIONS; EXERCISE MACHINES FOR PULL DOWNS, TRICEPS PRESSES, BUTTERFLIES, CHEST FLIES, LEG EXTENSIONS, BICEPS CURLS, SHOULDER PRESSES, ARM EXERCISES, BACK EXERCISES; EXERCISE EQUIPMENT, NAMELY, RESISTANCE MACHINES, CHEST PULLS, CHEST EXPANDERS, LEG WEIGHTS, MANUAL LEG EXERCISERS, STATIONARY CYCLES, VIRTUAL REALITY TRAINING CYCLES, STATIONARY EXERCISE BICYCLES AND ROLLERS THEREFORE, SHOULDER STRETCHER USING RESISTANCE CABLES, SHOULDER STRETCHER USING A CABLE, STAIR STEPPING MACHINES; EXERCISE TREADMILLS, AEROBIC STEPS; AEROBIC TRAMPOLINES; EXERCISE BENCHES, NAMELY, WEIGHT LIFTING BENCHES AND SIT UP BENCHES; EXERCISE EQUIPMENT, NAMELY, ROWING MACHINES; BOXING EQUIPMENT, NAMELY, BOXING SWIVEL MECHANISMS, PUNCHING BALLS FOR BOXING PRACTICE, TRAINING APPARATUS FOR BOXING, SHOES, BAGS, GLOVES, RINGS, AND SWIVELS (U.S. CLS. 22, 23, 38 AND 50).

FIRST USE 10-15-2007; IN COMMERCE 10-15-2007.

3,941,129. TIPPMANN SPORTS, LLC, BUFFALO GROVE, IL. SN 77-563,308. PUB. 2-2-2010, FILED 9-5-2008.



THE MARK CONSISTS OF THE LETTERS "SL" IN A CIRCLE AND "STRAIGHTLINE" HAS A LINE ACROSS THE CENTER ENDING AT THE LETTER "N" AND BEFORE THE LETTER "E".

FOR PAINTBALL MARKERS AND PARTS AND ACCESSORIES THEREFOR (U.S. CLS. 22, 23, 38 AND 50).  
FIRST USE 6-0-2009; IN COMMERCE 6-0-2009.

**CLASS 28—(Continued).**

3,941,150. DTM LTD., WOODLAND, WA. SN 77-596,936. PUB. 4-14-2009, FILED 10-21-2008.

**COLLECT FOUR!**

THE MARK CONSISTS OF STANDARD CHARACTERS WITHOUT CLAIM TO ANY PARTICULAR FONT, STYLE, SIZE, OR COLOR.

NO CLAIM IS MADE TO THE EXCLUSIVE RIGHT TO USE "COLLECT", APART FROM THE MARK AS SHOWN.

FOR TOYS, NAMELY, A DISK TO TOSS IN PLAYING A GAME WHEREIN OTHER DISKS ARE FLIPPED AND COLLECTED (U.S. CLS. 22, 23, 38 AND 50).

FIRST USE 9-29-2009; IN COMMERCE 11-18-2010.

3,941,160. BASIC CONCEPTS INTERNATIONAL LIMITED, TSIM SHA TSUI EAST, HONG KONG. SN 77-611,342. PUB. 5-11-2010, FILED 11-10-2008.



NO CLAIM IS MADE TO THE EXCLUSIVE RIGHT TO USE "GAMES", APART FROM THE MARK AS SHOWN.

THE MARK CONSISTS OF "3DA" STYLIZED WITH LINES THOUGH EACH ELEMENT ABOVE THE TERM "GAMES" THAT IS ON TOP OF A RECTANGULAR DESIGN AND THERE ARE THREE BLOCKS UNDER "3," "D" AND "A"; A PARTIAL SUN DESIGN IS LOCATED BEHIND THESE ELEMENTS.

FOR TOYS AND GAMES, NAMELY, ACTION SKILL GAMES, BATTERY OPERATED ACTION TOYS, BENDABLE TOYS, BOARD GAMES, CARD GAMES; CHILDREN'S GAMES, NAMELY, ACTION RECOGNITION TOYS, NAMELY, MOVEABLE PARTS ON 3D POP UP BOARD GAME, ACTION RECOGNITION BOARD GAMES, ACTION STRATEGY TOYS NAMELY, SPINNER AND CARDS FOR MOVING PLAYING PIECES AROUND BOARD, ACTION STRATEGY BOARD GAMES, ACTION TABLE TOP GAMES, NAMELY, PLAYING PIECES ON GAME BOARD FOR CHANGING THE COURSE OF THE BOARD GAME; CHILDREN'S MULTIPLE ACTIVITY TOYS, COLLECTIBLE TOY FIGURES, CONSTRUCTION TOYS, DISC TOSS TOYS, DOLLS, DOLLS ACCESSORIES, DOLLS CLOTHING, DRAWING TOYS, EDUCATIONAL TOY FOR THE PURPOSE OF THE DEMONSTRATION OF ALTERNATIVE ENERGY SOURCES, EDUCATIONAL TOYS FOR TEACHING COGNITIVE SKILLS TO CHILDREN, NAMELY, MANIPULATIVE TOY BLOCKS FOR DISPLAYING PATTERNS AND GROUPINGS; ELECTRIC ACTION TOYS; ELECTRONIC LEARNING TOYS, ELECTRONIC NOVELTY TOYS, NAMELY, TOYS THAT ELECTRONICALLY RECORD, PLAYBACK, AND DISTORT OR MANIPULATE VOICES AND SOUND; ELECTRONIC TOY VEHICLES, FANTASY CHARACTER TOYS, FLYING SAUCERS, HAND-POWERED NON-MECHANICAL FLYING TOY, INFLATABLE THIN RUBBER TOYS, INFLATABLE TOYS, JUMPING PLAY FIGURES, MAGNETIC ARTICLES, NAMELY, POSITIONABLE TOY FIGURES WITH MAGNETS, PICK UP TOY WITH

**CLASS 28—(Continued).**

MAGNET, NAMELY, PLAY WANDS WITH MAGNET AT ONE END AND THROWING TOY WITH MAGNET, NAMELY, DISC TOSSING TOYS WITH MAGNETS; MECHANICAL ACTION TOYS, MODELED PLASTIC TOY FIGURINES, OUTDOOR SUMMER WATER TOYS, NAMELY, TOY REUSABLE WATER FILLED BALL, WATER SQUIRTING GUNS, AND BEACH BALLS; PARLOUR GAMES, PARTY GAME, PLASTIC TOYS, NAMELY, PLASTIC TOY ANIMALS, PLAY AND TOY ACTION FIGURES; PLAYING CARDS, PLUSH TOYS, POP UP TOYS, POSITIONABLE PRINTED TOY FIGURES FOR USE IN GAMES, POSITIONABLE PRINTED TOY FIGURES FOR USE IN PUZZLES, POSITIONABLE TOY FIGURES, POSITIONABLE TWO DIMENSIONAL TOYS FOR USE IN GAMES, POSITIONABLE THREE DIMENSIONAL TOYS FOR USE IN GAMES, PRINTED POSITIONABLE TOYS FOR USE IN CHILDREN'S BOARD GAMES, PRINTING TOYS, PULL TOYS, PUNCHING TOYS, PUSH TOYS, PUZZLES, BOARD GAMES IN THE NATURE OF A QUIZ, RADIO CONTROLLED TOY VEHICLES, RUBBER CHARACTER TOYS, STRATEGY GAMES, NAMELY, STRATEGY ROLE PLAYING GAMES, STUFFED AND PLUSH TOYS, TALKING TOYS, THROWING GAMES, NAMELY, STRATEGY THROWING OBJECT GAME IN THE NATURE OF A DISK TOSS TOYS; BALLS FOR GAMES, NAMELY, BASEBALLS, SOCCER BALLS, CRICKET BALLS, AND FOOT BALLS; TOY ACTION FIGURES, TOY ANIMALS, TOY CARS, TOY FIGURES, TOY ROBOTS, TOY WATCHES, TOY WATER GLOBES, BATTERY-POWERED COMPUTER GAME WITH LCD SCREEN WHICH FEATURES ANIMATION AND SOUND EFFECTS; CHILDREN'S DRESS-UP ACCESSORIES, TRANSFORMING ROBOTIC TOY VEHICLE, TRANSFORMING ROBOTIC TOYS, TWO AND THREE DIMENSIONAL POSITIONABLE TOY FIGURES SOLD AS A UNIT WITH OTHER TOYS, WATER SQUIRTING TOYS, WIND-UP TOYS, WIND-UP WALKING TOYS, BOARD GAMES IN THE NATURE OF WORD GAMES, YO-YOS (U.S. CLS. 22, 23, 38 AND 50).

FIRST USE 8-0-2009; IN COMMERCE 8-0-2009.

**CLASS 28—(Continued).**

3,941,207. MONSTER FISH USA, LLC, MIRAMAR, FL. SN 77-659,787. PUB. 5-26-2009, FILED 1-29-2009.

## Pelagic Extreme

THE MARK CONSISTS OF STANDARD CHARACTERS WITHOUT CLAIM TO ANY PARTICULAR FONT, STYLE, SIZE, OR COLOR.

FOR ARTIFICIAL FISHING BAIT; ARTIFICIAL FISHING LURES; ARTIFICIAL FISHING WORMS; FISH HOOK REMOVERS; FISH HOOKS; FISHING CREELS; FISHING FLIES; FISHING FLOATS; FISHING FLY BOXES; FISHING GAFFS; FISHING HOOKS; FISHING LEADERS; FISHING LINES; FISHING LURE BOXES; FISHING LURE PARTS; FISHING LURES; FISHING LURES, NAMELY, LEECHES; FISHING LURES, NAMELY, PLASTIC WORMS; FISHING LURES, NAMELY, SPOONS; FISHING PLUGS; FISHING POLE HOLDERS WORN ON THE BODY; FISHING REELS; FISHING ROD BLANKS; FISHING ROD CASES; FISHING ROD HANDLES; FISHING ROD HOLDERS; FISHING ROD RACKS; FISHING RODS; FISHING SAFETY HARNESS; FISHING SINKERS; FISHING SPINNERS; FISHING TACKLE; FISHING TACKLE BOXES; FISHING TACKLE CONTAINERS; FISHING TACKLE, NAMELY, BOBBERS; FISHING TACKLE, NAMELY, LIGHTED BOBBERS; FISHING WEIGHTS; FLIES FOR USE IN FISHING; FLOATS FOR FISHING; HAND-HELD FISHING NETS; HAND-HELD FISHING NETS FOR SPORTSMEN; LINES FOR FISHING; LURES FOR FISHING; LURES FOR HUNTING OR FISHING; REELS FOR FISHING; RODS FOR FISHING (U.S. CLS. 22, 23, 38 AND 50).

FIRST USE 11-1-2009; IN COMMERCE 11-1-2009.

---

3,941,253. SUKAITIS, EDVINAS, NANTUCKET, MA. SN 77-712,036. PUB. 8-11-2009, FILED 4-11-2009.

## FlexiScore

THE MARK CONSISTS OF STANDARD CHARACTERS WITHOUT CLAIM TO ANY PARTICULAR FONT, STYLE, SIZE, OR COLOR.

FOR EXERCISING EQUIPMENT, NAMELY, YOGA MATS; PERSONAL EXERCISE MATS (U.S. CLS. 22, 23, 38 AND 50).

FIRST USE 6-1-2010; IN COMMERCE 11-1-2010.

**CLASS 28—(Continued).**

3,941,319. WARREN, TERRY GRAHAM, FRANKLIN, TN.  
SN 77-764,191. PUB. 11-24-2009, FILED 6-19-2009.

## CRUSH MASTER THE BAT SPEED SUPERCHARGER

THE MARK CONSISTS OF STANDARD CHARACTERS WITHOUT CLAIM TO ANY PARTICULAR FONT, STYLE, SIZE, OR COLOR.

NO CLAIM IS MADE TO THE EXCLUSIVE RIGHT TO USE "BAT SPEED", APART FROM THE MARK AS SHOWN.

FOR BASEBALL AND SOFTBALL TRAINING APPARATUS TO IMPROVE A PLAYER'S BAT SPEED (U.S. CLS. 22, 23, 38 AND 50).

FIRST USE 10-0-2010; IN COMMERCE 10-0-2010.

---

3,941,386. OUT OF THE BOX PUBLISHING, INC., WINDSOR, WI. SN 77-791,047. PUB. 12-15-2009, FILED 7-28-2009.

## SHAKE 'N TAKE

THE MARK CONSISTS OF STANDARD CHARACTERS WITHOUT CLAIM TO ANY PARTICULAR FONT, STYLE, SIZE, OR COLOR.

FOR PARTY GAMES (U.S. CLS. 22, 23, 38 AND 50).

FIRST USE 2-14-2010; IN COMMERCE 2-14-2010.

---

3,941,419. SPORTSENSE, LLC., NORWICH, CT. SN 77-802,541. PUB. 1-12-2010, FILED 8-12-2009.

## SwimSense

THE MARK CONSISTS OF STANDARD CHARACTERS WITHOUT CLAIM TO ANY PARTICULAR FONT, STYLE, SIZE, OR COLOR.

FOR SPORTING GOODS, NAMELY, A SPORTS TRAINING DEVICE TO IMPROVE STRENGTH, TONING, CONDITIONING, BALANCE, AND PROPRIOCEPTION (U.S. CLS. 22, 23, 38 AND 50).

FIRST USE 12-9-2010; IN COMMERCE 12-9-2010.

**CLASS 28—(Continued).**

3,941,457. BARNETT OUTDOORS, LLC, TARPON SPRINGS, FL. SN 77-825,093. PUB. 2-2-2010, FILED 9-11-2009.

## JACKAL

THE MARK CONSISTS OF STANDARD CHARACTERS WITHOUT CLAIM TO ANY PARTICULAR FONT, STYLE, SIZE, OR COLOR.

FOR CROSSBOWS (U.S. CLS. 22, 23, 38 AND 50).

FIRST USE 4-13-2010; IN COMMERCE 4-13-2010.

---

3,941,461. LUTHER EDWIN MILLER, WATERLOO, CANADA. SN 77-827,622. PUB. 6-8-2010, FILED 9-16-2009.

## TIPPY

THE MARK CONSISTS OF STANDARD CHARACTERS WITHOUT CLAIM TO ANY PARTICULAR FONT, STYLE, SIZE, OR COLOR.

FOR A BASEBALL STYLE GAME, NAMELY, BATS, BALLS, BASES AND A RULE BOOK SOLD AS A UNIT; REPLACEMENT PARTS THEREOF (U.S. CLS. 22, 23, 38 AND 50).

FIRST USE 4-3-2009; IN COMMERCE 9-17-2009.

---

3,941,466. MATTEL, INC., EL SEGUNDO, CA. SN 77-829,097. PUB. 7-20-2010, FILED 9-17-2009.

## BAJA BULLET

THE MARK CONSISTS OF STANDARD CHARACTERS WITHOUT CLAIM TO ANY PARTICULAR FONT, STYLE, SIZE, OR COLOR.

NO CLAIM IS MADE TO THE EXCLUSIVE RIGHT TO USE "BAJA", APART FROM THE MARK AS SHOWN.

FOR TOYS, GAMES AND PLAYTHINGS, NAMELY, TOY VEHICLES AND ACCESSORIES THEREFOR (U.S. CLS. 22, 23, 38 AND 50).

FIRST USE 8-17-2010; IN COMMERCE 8-17-2010.

**CLASS 28—(Continued).**

3,941,521. BIG BALLS GOLF, LLC, OLYMPIA, WA. SN 77-858,247. PUB. 6-15-2010, FILED 10-27-2009.

**BIG BALLS GOLF**

THE MARK CONSISTS OF STANDARD CHARACTERS WITHOUT CLAIM TO ANY PARTICULAR FONT, STYLE, SIZE, OR COLOR.

NO CLAIM IS MADE TO THE EXCLUSIVE RIGHT TO USE "GOLF", APART FROM THE MARK AS SHOWN.

FOR BALLS FOR SPORTS; GOLF BAGS; GOLF CLUB COVERS; GOLF CLUBS; GOLF TEES (U.S. CLS. 22, 23, 38 AND 50).

FIRST USE 1-1-2011; IN COMMERCE 1-1-2011.

3,941,661. WIZARDS OF THE COAST LLC, PAWTUCKET, RI. SN 77-895,620. PUB. 11-23-2010, FILED 12-17-2009.

**COUNTEROFFENSIVE 1941-1943**

THE MARK CONSISTS OF STANDARD CHARACTERS WITHOUT CLAIM TO ANY PARTICULAR FONT, STYLE, SIZE, OR COLOR.

FOR BOARD GAMES, PARLOR GAMES (U.S. CLS. 22, 23, 38 AND 50).

FIRST USE 10-26-2010; IN COMMERCE 10-26-2010.

3,941,694. LEAPFROG ENTERPRISES, INC., EMERYVILLE, CA. SN 77-900,221. PUB. 5-18-2010, FILED 12-23-2009.

**MY OWN LEAPTOP**

THE MARK CONSISTS OF STANDARD CHARACTERS WITHOUT CLAIM TO ANY PARTICULAR FONT, STYLE, SIZE, OR COLOR.

OWNER OF U.S. REG. NO. 3,146,479.

FOR TOYS, GAMES AND PLAYTHINGS, NAMELY, INTERACTIVE MULTIPLE ACTIVITY TOYS (U.S. CLS. 22, 23, 38 AND 50).

FIRST USE 5-31-2010; IN COMMERCE 5-31-2010.

**CLASS 28—(Continued).**

3,941,724. WGI INNOVATIONS, LTD., GRAND PRAIRIE, TX. SN 77-906,182. PUB. 5-4-2010, FILED 1-6-2010.

**ECHO**

THE MARK CONSISTS OF STANDARD CHARACTERS WITHOUT CLAIM TO ANY PARTICULAR FONT, STYLE, SIZE, OR COLOR.

FOR ELECTRONIC ANIMAL CALLS FOR RECREATION AND HUNTING ACTIVITIES (U.S. CLS. 22, 23, 38 AND 50).

FIRST USE 10-27-2010; IN COMMERCE 10-27-2010.

3,941,730. DANNY HESTER'S PORTABLE GYM, LLC, VENTURA, CA. SN 77-907,472. PUB. 5-25-2010, FILED 1-7-2010.

**G FLEX**

THE MARK CONSISTS OF STANDARD CHARACTERS WITHOUT CLAIM TO ANY PARTICULAR FONT, STYLE, SIZE, OR COLOR.

FOR MANUALLY-OPERATED EXERCISE EQUIPMENT (U.S. CLS. 22, 23, 38 AND 50).

FIRST USE 3-1-2009; IN COMMERCE 3-1-2009.

3,941,767. KABUSHIKI KAISHA BANDAI, AKA BANDAI CO., LTD., TOKYO 111-8081, JAPAN. SN 77-913,383. PUB. 6-1-2010, FILED 1-15-2010.

**TAMATOWN**

THE MARK CONSISTS OF STANDARD CHARACTERS WITHOUT CLAIM TO ANY PARTICULAR FONT, STYLE, SIZE, OR COLOR.

OWNER OF U.S. REG. NO. 3,372,943.

FOR DOLLS; DOLL ACCESSORIES; PLAYSETS FOR DOLLS; LCD GAME MACHINES; TOY FIGURES; CARRYING CASE FOR DOLLS, DOLL ACCESSORIES, PLAYSETS AND LCD GAME MACHINES (U.S. CLS. 22, 23, 38 AND 50).

FIRST USE 7-15-2010; IN COMMERCE 7-15-2010.

**CLASS 28—(Continued).**

3,941,788. DAYS OF WONDER, INC., LOS ALTOS, CA. SN 77-916,985. PUB. 6-8-2010, FILED 1-21-2010.

**FICTIONAIRE**

THE MARK CONSISTS OF STANDARD CHARACTERS WITHOUT CLAIM TO ANY PARTICULAR FONT, STYLE, SIZE, OR COLOR.

FOR CARD GAMES; EQUIPMENT SOLD AS A UNIT FOR PLAYING CARD GAMES; PARLOUR GAMES (U.S. CLS. 22, 23, 38 AND 50).

FIRST USE 8-25-2010; IN COMMERCE 8-25-2010.

3,941,809. MAZOR, ROBERT, SARASOTA, FL. SN 77-920,070. PUB. 6-15-2010, FILED 1-26-2010.

**BANDOCIZER**

THE MARK CONSISTS OF STANDARD CHARACTERS WITHOUT CLAIM TO ANY PARTICULAR FONT, STYLE, SIZE, OR COLOR.

FOR MANUALLY-OPERATED EXERCISE EQUIPMENT (U.S. CLS. 22, 23, 38 AND 50).

FIRST USE 1-0-1998; IN COMMERCE 1-0-1998.

3,941,813. SPONTUNEOUS GAMES, INC., BILLINGS, MT. SN 77-920,214. PUB. 6-15-2010, FILED 1-26-2010.

**SPONTUNEOUS**

THE MARK CONSISTS OF STANDARD CHARACTERS WITHOUT CLAIM TO ANY PARTICULAR FONT, STYLE, SIZE, OR COLOR.

FOR BOARD GAMES (U.S. CLS. 22, 23, 38 AND 50). FIRST USE 8-10-2010; IN COMMERCE 8-10-2010.

**CLASS 28—(Continued).**

3,941,844. OWEN CRAIG POLLARD, SAN MARCOS, CA. SN 77-925,662. PUB. 6-15-2010, FILED 2-2-2010.

**EVERGOLF**

THE MARK CONSISTS OF STANDARD CHARACTERS WITHOUT CLAIM TO ANY PARTICULAR FONT, STYLE, SIZE, OR COLOR.

FOR GOLF CLUB COVERS; HEAD COVERS FOR GOLF CLUBS (U.S. CLS. 22, 23, 38 AND 50).

FIRST USE 1-1-2006; IN COMMERCE 1-1-2006.

3,941,856. KABUSHIKI KAISHA BANDAI, AKA BANDAI CO., LTD., TOKYO 111-8081, JAPAN. SN 77-927,379. PUB. 6-1-2010, FILED 2-3-2010.

**Tama-Go**

THE MARK CONSISTS OF STANDARD CHARACTERS WITHOUT CLAIM TO ANY PARTICULAR FONT, STYLE, SIZE, OR COLOR.

FOR LCD GAME MACHINES; TOY FIGURES; CARRYING CASE FOR LCD GAME MACHINES (U.S. CLS. 22, 23, 38 AND 50).

FIRST USE 8-1-2010; IN COMMERCE 8-1-2010.

3,941,862. ENERTEC ENTERPRISES, LTD., KOWLOON, HONG KONG. SN 77-928,265. PUB. 6-29-2010, FILED 2-4-2010.



NO CLAIM IS MADE TO THE EXCLUSIVE RIGHT TO USE "GIRL", APART FROM THE MARK AS SHOWN.

THE COLOR(S) PURPLE, PINK, BLUE, BLACK, AND WHITE IS/ARE CLAIMED AS A FEATURE OF THE MARK.

**CLASS 28—(Continued).**

THE MARK CONSISTS OF THE STYLIZED PURPLE WORDING "MY" AND THE STYLIZED PINK WORDING "GIRL" WITH THE DOT ON THE "I" IN THE SHAPE OF A PINK HEART, ENCOMPASSED BY A BLUE OUTLINE FORMING THE EXTERIOR SHAPES OF THE LETTERS WITH BLACK SHADING, AND THE SPACE BETWEEN THE LETTERS AND THE OUTLINE IN WHITE.

FOR DOLLS AND ACCESSORIES THEREFOR (U.S. CLS. 22, 23, 38 AND 50).

FIRST USE 1-1-2010; IN COMMERCE 8-1-2010.

3,941,932. FOX 40 INTERNATIONAL INC, STONEY CREEK, CANADA. SN 77-945,090. PUB. 7-20-2010, FILED 2-25-2010.

**RACEGUARD**

THE MARK CONSISTS OF STANDARD CHARACTERS WITHOUT CLAIM TO ANY PARTICULAR FONT, STYLE, SIZE, OR COLOR.

FOR MOUTHGUARDS FOR ATHLETIC PURPOSES (U.S. CLS. 22, 23, 38 AND 50).

FIRST USE 2-9-2011; IN COMMERCE 2-9-2011.

3,941,993. CREATIVE OUTDOOR PRODUCTS, INC., CRAWFORDSVILLE, IN. SN 77-965,110. PUB. 8-10-2010, FILED 3-22-2010.

**THUNDERBOLT**

THE MARK CONSISTS OF STANDARD CHARACTERS WITHOUT CLAIM TO ANY PARTICULAR FONT, STYLE, SIZE, OR COLOR.

FOR TOY GUNS (U.S. CLS. 22, 23, 38 AND 50).

FIRST USE 1-21-2011; IN COMMERCE 1-21-2011.

3,942,090. SRI SPORTS KABUSHIKI KAISHA, TA SRI SPORTS LIMITED, KOBE-SHI, HYOGO, JAPAN. SN 85-005,949. PUB. 9-7-2010, FILED 4-5-2010.

**TOUR YELLOW**

THE MARK CONSISTS OF STANDARD CHARACTERS WITHOUT CLAIM TO ANY PARTICULAR FONT, STYLE, SIZE, OR COLOR.

**CLASS 28—(Continued).**

NO CLAIM IS MADE TO THE EXCLUSIVE RIGHT TO USE "YELLOW", APART FROM THE MARK AS SHOWN.

FOR GOLF BALLS (U.S. CLS. 22, 23, 38 AND 50).

FIRST USE 2-9-2010; IN COMMERCE 2-9-2010.

3,942,093. JUNIOR LEARNING INCORPORATED, DBA JUNIOR LEARNING INCORPORATED, HUNTINGTON BEACH, CA. SN 85-008,097. PUB. 9-7-2010, FILED 4-7-2010.



THE COLOR(S) RED, ORANGE, BLACK, WHITE AND PALE BLUE IS/ARE CLAIMED AS A FEATURE OF THE MARK.

THE MARK CONSISTS OF THE WORD "SPELLIGATOR" IN SHADES OF RED AND ORANGE IN A CUSTOMIZED FONT WITH A THICK, PUFFY WHITE OUTLINE AROUND THE WORD WITH A PALE BLUE EDGING AND A BLACK DROP SHADOW; THE "LL" IN THE WORD IS FORMED BY TWO ALLIGATORS WITH CURLY TAILS.

FOR EQUIPMENT SOLD AS A UNIT FOR PLAYING AN EDUCATIONAL SPELLING PLASTIC BOARD GAME (U.S. CLS. 22, 23, 38 AND 50).

FIRST USE 12-1-2010; IN COMMERCE 1-1-2011.

3,942,094. JUNIOR LEARNING INCORPORATED, DBA JUNIOR LEARNING INCORPORATED, HUNTINGTON BEACH, CA. SN 85-008,139. PUB. 9-7-2010, FILED 4-7-2010.



THE COLOR(S) RED, BLACK, GRAY AND WHITE IS/ARE CLAIMED AS A FEATURE OF THE MARK.

THE MARK CONSISTS OF THE WORDING "WHAT'S MY NUMBER?" IN TWO CUSTOMIZED FONTS, WITH THE CURVED WORDING "WHAT'S MY" STYLIZED IN RED WITH WHITE OUTLINE AND A PALE GREY DROP SHADOW APPEARING ABOVE THE TERM "NUMBER" STYLIZED IN BLACK WITH EACH LETTER CONTAINED WITHIN AN IMAGE DEPICTING A WHITE PLAYING CARD, WITH EACH PLAYING CARD STYLIZED WITH A BLACK DROP SHADOW, AND THE FINAL PLAYING CARD CARRIER CONTAINS A QUESTION MARK WITH A DIAMOND SHAPE IN PLACE OF THE CIRCLE.

FOR EQUIPMENT SOLD AS A UNIT FOR PLAYING AN EDUCATIONAL MATHEMATICS PLASTIC BOARD GAME (U.S. CLS. 22, 23, 38 AND 50).

FIRST USE 12-1-2010; IN COMMERCE 1-1-2011.

**CLASS 28—(Continued).**

3,942,095. JUNIOR LEARNING INCORPORATED, DBA JUNIOR LEARNING INCORPORATED, HUNTINGTON BEACH, CA. SN 85-008,215. PUB. 9-7-2010, FILED 4-7-2010.



NO CLAIM IS MADE TO THE EXCLUSIVE RIGHT TO USE "TRAY", APART FROM THE MARK AS SHOWN.

THE COLOR(S) ORANGE, PURPLE, GRAY AND WHITE IS/ARE CLAIMED AS A FEATURE OF THE MARK.

THE MARK CONSISTS OF A DEPICTION OF THE TEN TILE TRAY WITH THE WORDS "SMART TRAY" IN WHITE CAPITAL LETTERS IN A VAG ROUNDED FONT, WITH EACH LETTER SHOWN ON A SQUARE TILE; THE WHITE LETTERS THAT MAKE UP "SMART" ARE CONTAINED WITHIN ORANGE TILES AND THE WHITE LETTERS THAT MAKE UP "TRAY" ARE CONTAINED WITHIN PURPLE TILES, AND THE FINAL PURPLE TILE PIECE IS ANGLED DOWNWARD, PROTRUDING SLIGHTLY OFF THE END OF THE TRAY AND HAS A PIE-SHAPED PORTION THAT APPEARS IN A LIGHTER PURPLE AND A GRAY DROP SHADOW. ALL THE COLORED TILES REST ON A GRAY BACKGROUND IN A QUADRILATERAL SHAPE.

FOR EQUIPMENT SOLD AS A UNIT IN THE FORM OF A SELF-CORRECTING TILE TRAY FOR PLAYING EDUCATIONAL GAMES AND ACTIVITIES (U.S. CLS. 22, 23, 38 AND 50).

FIRST USE 12-1-2010; IN COMMERCE 1-1-2011.

3,942,154. TIPPMANN SPORTS, LLC, BUFFALO GROVE, IL. SN 85-037,916. PUB. 10-26-2010, FILED 5-13-2010.

# TIPX

THE MARK CONSISTS OF STANDARD CHARACTERS WITHOUT CLAIM TO ANY PARTICULAR FONT, STYLE, SIZE, OR COLOR.

FOR PAINTBALL MARKERS AND PARTS THEREFOR AND ACCESSORIES THEREFOR (U.S. CLS. 22, 23, 38 AND 50).

FIRST USE 1-11-2011; IN COMMERCE 1-11-2011.

**CLASS 28—(Continued).**

3,942,190. NET WORTH MEDIA, LLC, JUPITER, FL. SN 85-048,416. PUB. 11-2-2010, FILED 5-26-2010.

# EDGE

THE MARK CONSISTS OF STANDARD CHARACTERS WITHOUT CLAIM TO ANY PARTICULAR FONT, STYLE, SIZE, OR COLOR.

FOR RADIO-CONTROLLED MODEL HELICOPTER PARTS, NAMELY, MODEL HELICOPTER ROTOR BLADES (U.S. CLS. 22, 23, 38 AND 50).

FIRST USE 4-4-2009; IN COMMERCE 5-31-2009.

3,942,198. THE HAYWIRE GROUP, INC., INDIAN ORCHARD, MA. SN 85-050,405. PUB. 10-26-2010, FILED 5-28-2010.

# CAT'S PAJAMAS

THE MARK CONSISTS OF STANDARD CHARACTERS WITHOUT CLAIM TO ANY PARTICULAR FONT, STYLE, SIZE, OR COLOR.

FOR TOYS AND GAMES, NAMELY, BOARD GAMES (U.S. CLS. 22, 23, 38 AND 50).

FIRST USE 12-1-2010; IN COMMERCE 12-1-2010.

3,942,259. STICK-AID LLC, LONG BEACH, CA. SN 85-066,931. PUB. 11-23-2010, FILED 6-18-2010.



THE MARK CONSISTS OF A ROBOT HOCKEY PLAYER WITH A HOCKEY HELMET AND STICK THAT DISPLAYS A ROLL OF TAPE ON THE END OF THE BLADE OF THE STICK. THE BACKGROUND OF THE MARK IS A HALF CIRCLE WITH SERRATED EDGES. STRETCHING ACROSS THE BOTTOM THE HALF CIRCLE DESIGN IS THE STYLIZED WORDING "TOE TAPE-IT". BELOW THE "PE-IT" PORTION OF "TAPE-IT" IS THE STYLIZED WORDING "FOR THE PERFECT DRAG!"

FOR ATHLETIC SPORTING GOODS, NAMELY, ADHESIVE TAPE FOR USE IN HOCKEY (U.S. CLS. 22, 23, 38 AND 50).

FIRST USE 9-14-2010; IN COMMERCE 9-14-2010.



**CLASS 28—(Continued).**

3,942,271. THE ORVIS COMPANY, INC., SUNDERLAND, VT. SN 85-071,453. PUB. 11-9-2010, FILED 6-25-2010.

**ACCESS**

THE MARK CONSISTS OF STANDARD CHARACTERS WITHOUT CLAIM TO ANY PARTICULAR FONT, STYLE, SIZE, OR COLOR.

FOR FISHING TACKLE, FISHING RODS, FISHING REELS, FLY FISHING RODS, FLY FISHING REELS (U.S. CLS. 22, 23, 38 AND 50).

FIRST USE 10-0-2010; IN COMMERCE 10-0-2010.

3,942,304. THE BOOKSOURCE, INC, ST. LOUIS, MO. SN 85-084,430. PUB. 12-14-2010, FILED 7-14-2010.

**STONE SOUP**

THE MARK CONSISTS OF STANDARD CHARACTERS WITHOUT CLAIM TO ANY PARTICULAR FONT, STYLE, SIZE, OR COLOR.

FOR BOARD GAMES (U.S. CLS. 22, 23, 38 AND 50).

FIRST USE 1-1-2011; IN COMMERCE 1-1-2011.

3,942,305. BOOKSOURCE, INC., THE, ST. LOUIS, MO. SN 85-084,473. PUB. 10-19-2010, FILED 7-14-2010.

**COUNT YOUR CHICKENS**

THE MARK CONSISTS OF STANDARD CHARACTERS WITHOUT CLAIM TO ANY PARTICULAR FONT, STYLE, SIZE, OR COLOR.

FOR BOARD GAMES (U.S. CLS. 22, 23, 38 AND 50).

FIRST USE 1-1-2011; IN COMMERCE 1-1-2011.

**CLASS 29—MEATS AND PROCESSED FOODS****CLASS 29—(Continued).**

3,941,063. MEDITCO, INC., DBA PHOENICIA SPECIALTY FOODS, HOUSTON, TX. SN 77-375,942. PUB. 6-3-2008, FILED 1-18-2008.

**ZAHRA'S**

THE MARK CONSISTS OF STANDARD CHARACTERS WITHOUT CLAIM TO ANY PARTICULAR FONT, STYLE, SIZE, OR COLOR.

FOR DRIED BEANS, ROASTED NUTS, SALTED NUTS, DRIED FRUITS, PROCESSED EDIBLE SEEDS, COCONUT POWDER (U.S. CL. 46).

FIRST USE 2-16-2011; IN COMMERCE 2-16-2011.

3,941,078. SCOVILL CREEK FARM LLC, DALTON CITY, IL. SN 77-438,626. PUB. 8-19-2008, FILED 4-3-2008.

**Scovill Creek Farm**

THE MARK CONSISTS OF STANDARD CHARACTERS WITHOUT CLAIM TO ANY PARTICULAR FONT, STYLE, SIZE, OR COLOR.

NO CLAIM IS MADE TO THE EXCLUSIVE RIGHT TO USE "FARM", APART FROM THE MARK AS SHOWN.

FOR MEAT, FISH, POULTRY AND GAME; MEAT EXTRACTS; PRESERVED, DRIED AND COOKED FRUITS AND VEGETABLES; JELLIES, JAMS; FRUIT SAUCES, NAMELY, APPLE SAUCE; EGGS, MILK AND MILK PRODUCTS EXCLUDING ICE CREAM, ICE MILK AND FROZEN YOGURT; EDIBLE OILS AND FATS (U.S. CL. 46).

FIRST USE 6-15-2009; IN COMMERCE 7-4-2009.

3,941,180. PANPROD S.A., KALAMATA, MESSINIA, GREECE. SN 77-634,295. PUB. 11-17-2009, FILED 12-16-2008.

**KALLISTO MESSINIAN OLIVE GROVES**

THE MARK CONSISTS OF STANDARD CHARACTERS WITHOUT CLAIM TO ANY PARTICULAR FONT, STYLE, SIZE, OR COLOR.

NO CLAIM IS MADE TO THE EXCLUSIVE RIGHT TO USE "MESSINIAN OLIVE GROVES", APART FROM THE MARK AS SHOWN.

THE NAME "KALLISTO" DOES NOT IDENTIFY A LIVING INDIVIDUAL.

FOR PROCESSED OLIVES, OLIVE OIL, AND OLIVE PASTE (U.S. CL. 46).

FIRST USE 1-4-2011; IN COMMERCE 1-4-2011.

**CLASS 29—(Continued).**

3,941,217. FRITO-LAY NORTH AMERICA, INC., PLANO, TX. SN 77-666,218. PUB. 11-17-2009, FILED 2-9-2009.



OWNER OF U.S. REG. NOS. 841,324, 2,940,564, AND OTHERS.

THE MARK CONSISTS OF A FANCIFUL SMILING FACE ABOVE THE WORDS "FRITO LAY DOUBLENUTS" OVERLAID UPON AN OVAL SHAPE.

FOR PROCESSED NUTS (U.S. CL. 46).  
FIRST USE 6-0-2009; IN COMMERCE 6-0-2009.

3,941,219. KOVACH, MATTHEW J, SYRACUSE, NY. SN 77-666,904. PUB. 6-9-2009, FILED 2-10-2009.

## RejuvN8

THE MARK CONSISTS OF STANDARD CHARACTERS WITHOUT CLAIM TO ANY PARTICULAR FONT, STYLE, SIZE, OR COLOR.

FOR FRUIT AND SOY BASED SNACK FOOD; FRUIT-BASED SNACK FOOD; NUT AND SEED-BASED SNACK BARS; SOY-BASED FOOD BARS; VEGETABLE-BASED SNACK FOODS (U.S. CL. 46).

FIRST USE 2-3-2011; IN COMMERCE 2-3-2011.

3,941,220. KOVACH, MATTHEW J, SYRACUSE, NY. SN 77-666,908. PUB. 6-9-2009, FILED 2-10-2009.

## Strength Energy Life

THE MARK CONSISTS OF STANDARD CHARACTERS WITHOUT CLAIM TO ANY PARTICULAR FONT, STYLE, SIZE, OR COLOR.

FOR FRUIT AND SOY BASED SNACK FOOD; FRUIT-BASED ORGANIC FOOD BARS; NUT AND SEED-BASED SNACK BARS; PROTEIN BASED, NUTRIENT-DENSE SNACK BARS; SOY-BASED FOOD BARS; VEGETABLE-BASED SNACK FOODS (U.S. CL. 46).

FIRST USE 2-3-2011; IN COMMERCE 2-3-2011.

**CLASS 29—(Continued).**

3,941,347. CARGILL, INCORPORATED, WAYZATA, MN. SN 77-775,250. PUB. 12-1-2009, FILED 7-7-2009.

## GRILL CONTROL

THE MARK CONSISTS OF STANDARD CHARACTERS WITHOUT CLAIM TO ANY PARTICULAR FONT, STYLE, SIZE, OR COLOR.

FOR PROCESSED EGGS (U.S. CL. 46).  
FIRST USE 10-13-2009; IN COMMERCE 10-13-2009.

3,941,540. MARFOOD USA, INC., TAYLOR, MI. SN 77-866,673. PUB. 3-9-2010, FILED 11-6-2009.

## THERE IS ONLY ONE PEMMICAN, ALL THE REST ARE JERKY

THE MARK CONSISTS OF STANDARD CHARACTERS WITHOUT CLAIM TO ANY PARTICULAR FONT, STYLE, SIZE, OR COLOR.

OWNER OF U.S. REG. NOS. 2,407,232, 3,102,839, AND OTHERS.

FOR BEEF JERKY; MEAT-BASED SNACK FOODS (U.S. CL. 46).

FIRST USE 7-0-2010; IN COMMERCE 7-0-2010.

3,941,569. CHEVYS RESTAURANTS, LLC, CYPRESS, CA. SN 77-875,783. PUB. 4-27-2010, FILED 11-18-2009.

## CHEVYS FRESH MEX

THE MARK CONSISTS OF STANDARD CHARACTERS WITHOUT CLAIM TO ANY PARTICULAR FONT, STYLE, SIZE, OR COLOR.

OWNER OF U.S. REG. NOS. 2,066,652, 2,251,029, AND 3,170,878.

NO CLAIM IS MADE TO THE EXCLUSIVE RIGHT TO USE "FRESH MEX", APART FROM THE MARK AS SHOWN.

FOR FROZEN, PREPARED OR PACKAGED MEALS CONSISTING PRIMARILY OF MEAT, FISH, POULTRY OR VEGETABLES; GUACAMOLE, DIPS (U.S. CL. 46).

FIRST USE 11-9-2010; IN COMMERCE 11-9-2010.

**CLASS 29—(Continued).**

3,941,572. THRIVE FOODS LLC, LINDON, UT. SN 77-876,531. PUB. 4-20-2010, FILED 11-19-2009.

**FOOD STORAGE MADE EASY**

THE MARK CONSISTS OF STANDARD CHARACTERS WITHOUT CLAIM TO ANY PARTICULAR FONT, STYLE, SIZE, OR COLOR.

NO CLAIM IS MADE TO THE EXCLUSIVE RIGHT TO USE "FOOD STORAGE", APART FROM THE MARK AS SHOWN.

FOR PROCESSED FRUITS, VEGETABLES, LEGUMES, MILK, CHEESE, AND MEATS STORED IN DRY, FREEZE DRIED, DEHYDRATED FORM, OR CANNED FORM (U.S. CL. 46).

FIRST USE 12-15-2005; IN COMMERCE 12-15-2005.

---

3,941,596. SHAMROCK FOODS COMPANY, PHOENIX, AZ. SN 77-880,585. PUB. 4-20-2010, FILED 11-25-2009.

**CAFÉ COMPLEMENTS**

THE MARK CONSISTS OF STANDARD CHARACTERS WITHOUT CLAIM TO ANY PARTICULAR FONT, STYLE, SIZE, OR COLOR.

NO CLAIM IS MADE TO THE EXCLUSIVE RIGHT TO USE "CAFÉ", APART FROM THE MARK AS SHOWN.

FOR NON-DAIRY CREAMER (U.S. CL. 46).  
FIRST USE 1-29-2010; IN COMMERCE 1-29-2010.

---

3,941,640. FOUR TINES LLC, FORMERLY RED TRACTOR FOODS LLC, EAST QUOGUE, NY. SN 77-894,235. PUB. 5-18-2010, FILED 12-15-2009.

**Four Tines**

THE MARK CONSISTS OF STANDARD CHARACTERS WITHOUT CLAIM TO ANY PARTICULAR FONT, STYLE, SIZE, OR COLOR.

FOR FROZEN VEGETABLE-BASED ENTREES (U.S. CL. 46).

FIRST USE 6-1-2010; IN COMMERCE 10-1-2010.

**CLASS 29—(Continued).**

3,941,641. FOUR TINES LLC, FORMERLY RED TRACTOR FOODS LLC, EAST QUOGUE, NY. SN 77-894,237. PUB. 5-18-2010, FILED 12-15-2009.



THE COLOR(S) ORANGE (PANTONE<sup>(7)</sup> 8943), BROWN (PANTONE<sup>(7)</sup> 4625), BLACK AND WHITE IS/ARE CLAIMED AS A FEATURE OF THE MARK.

THE MARK CONSISTS OF A CIRCLE WITH SMALL PROTUBERANCES ON THE LEFT AND RIGHT SIDES. THE WORD "FOUR", IN CAPITAL LETTERS IN A CUSTOMIZED BREVIA FONT, CURVES AROUND THE TOP HALF OF THE INSIDE OF THE CIRCLE AND THE WORD "TINES", IN CAPITAL LETTERS IN A CUSTOMIZED BREVIA FONT, CURVES AROUND THE LOWER HALF OF THE INSIDE OF THE CIRCLE. A FORK IS HORIZONTAL IN THE CENTER OF THE CIRCLE, WITH ITS TINES POINTING TO THE RIGHT, THE LETTERING FOR THE WORDS "FOUR" AND "TINES" AND THE FORK ARE ALL IN THE COLOR BROWN (A RICH, DARK, WARM BROWN, PANTONE<sup>(7)</sup> 4625). A WHITE LINE IN A HALF CIRCLE SEPARATES THE WORD "FOUR" FROM THE FORK. A WHITE LINE IN A HALF CIRCLE SEPARATES THE WORD "TINES" FROM THE FORK. THERE IS A WHITE FOUR POINTED STAR TO THE LEFT OF THE FORK AND A WHITE FOUR POINTED STAR TO THE RIGHT OF THE FORK. EVERYTHING INSIDE THE CIRCLE, OTHER THAN THE BROWN AND WHITE PIECES DESCRIBED, IS ORANGE (A CARAMEL COLORED ORANGE, PANTONE<sup>(7)</sup> 8943).

FOR FROZEN VEGETABLE-BASED ENTREES (U.S. CL. 46).

FIRST USE 6-1-2010; IN COMMERCE 10-1-2010.

---

3,941,642. FOUR TINES LLC, FORMERLY RED TRACTOR FOODS LLC, EAST QUOGUE, NY. SN 77-894,238. PUB. 5-18-2010, FILED 12-16-2009.

**VEGETABLES MADE DELICIOUS**

THE MARK CONSISTS OF STANDARD CHARACTERS WITHOUT CLAIM TO ANY PARTICULAR FONT, STYLE, SIZE, OR COLOR.

FOR FROZEN VEGETABLE-BASED ENTREES (U.S. CL. 46).

FIRST USE 6-1-2010; IN COMMERCE 10-1-2010.

**CLASS 29—(Continued).**

3,941,784. VERDI, LLC, BEAR CREEK, WI. SN 77-915,933.  
PUB. 9-14-2010, FILED 1-20-2010.

# VERDI

THE MARK CONSISTS OF STANDARD CHARACTERS WITHOUT CLAIM TO ANY PARTICULAR FONT, STYLE, SIZE, OR COLOR.

THE ENGLISH TRANSLATION OF "VERDI" IN THE MARK IS "GREENS".  
FOR PROCESSED CASTELVETRANO OLIVES (U.S. CL. 46).

FIRST USE 1-24-2011; IN COMMERCE 1-24-2011.

3,941,804. KAP'S WHOLESALE FOOD SERVICES, INC.,  
DETROIT, MI. SN 77-919,108. PUB. 6-8-2010, FILED 1-25-  
2010.

## TIMBER VALLEY FARMS

THE MARK CONSISTS OF STANDARD CHARACTERS WITHOUT CLAIM TO ANY PARTICULAR FONT, STYLE, SIZE, OR COLOR.

NO CLAIM IS MADE TO THE EXCLUSIVE RIGHT TO USE "FARMS", APART FROM THE MARK AS SHOWN.

FOR MEAT (U.S. CL. 46).  
FIRST USE 9-30-2010; IN COMMERCE 9-30-2010.

3,941,860. THE PROCTER & GAMBLE COMPANY, CINCIN-  
NATI, OH. SN 77-927,679. PUB. 6-8-2010, FILED 2-4-2010.

## TEST YOUR TASTE BUDS!

THE MARK CONSISTS OF STANDARD CHARACTERS WITHOUT CLAIM TO ANY PARTICULAR FONT, STYLE, SIZE, OR COLOR.

FOR POTATO CHIPS AND CRISPS (U.S. CL. 46).  
FIRST USE 3-31-2010; IN COMMERCE 3-31-2010.

**CLASS 29—(Continued).**

3,941,870. MYMENU CANADA INC., KITCHENER, ONTAR-  
IO, CANADA. SN 77-929,334. PUB. 6-22-2010, FILED 2-5-  
2010.

# BUTCHER'S GRIND

THE MARK CONSISTS OF STANDARD CHARACTERS WITHOUT CLAIM TO ANY PARTICULAR FONT, STYLE, SIZE, OR COLOR.

FOR MEAT; HAMBURGER MEAT; HAMBURGER PATTIES (U.S. CL. 46).  
FIRST USE 5-0-2010; IN COMMERCE 5-0-2010.

3,941,922. E & H DISTRIBUTING, LLC, ROSEMONT, IL. SN  
77-943,234. PUB. 6-15-2010, FILED 2-24-2010.

## U.S. FOODSERVICE CATTLEMAN'S SELECTION

THE MARK CONSISTS OF STANDARD CHARACTERS WITHOUT CLAIM TO ANY PARTICULAR FONT, STYLE, SIZE, OR COLOR.

OWNER OF U.S. REG. NOS. 2,411,041, 3,017,715, AND OTHERS.

SEC. 2(F) AS TO "U.S. FOODSERVICE" AND "SELEC-  
TION".

FOR BEEF; MEAT (U.S. CL. 46).  
FIRST USE 1-21-2011; IN COMMERCE 1-21-2011.

3,941,934. LOCAL PRIDE LLC, WEST ORANGE, NJ. SN 77-  
945,495. PUB. 8-3-2010, FILED 2-25-2010.



NO CLAIM IS MADE TO THE EXCLUSIVE RIGHT TO USE "LOCAL", APART FROM THE MARK AS SHOWN.

THE COLOR(S) BLACK, LIGHT GREEN, AND DARK GREEN IS/ARE CLAIMED AS A FEATURE OF THE MARK.

**CLASS 29—(Continued).**

THE MARK CONSISTS OF THE WORDS "LOCAL PRIDE" INSIDE A BLACK RECTANGULAR BANNER WITH A LIGHT GREEN AND DARK GREEN BORDER ABOVE, AND 2 SWIRLING LIGHT GREEN AND BLACK ARROWS ABOVE AND BELOW. THE BANNER IS SURROUNDED BY 4 DARK GREEN LINES WITH LIGHT AND DARK GREEN LEAVES.

FOR ACIDOPHILUS MILK; CANNED FRUITS; CANNED FRUITS AND VEGETABLES; CANNED TOMATOES; CANNED VEGETABLES; CANNED, COOKED OR OTHERWISE PROCESSED TOMATOES; CHEESE; CREAM CHEESE; CUT FRUITS; CUT VEGETABLES; DAIRY PRODUCTS EXCLUDING ICE CREAM, ICE MILK AND FROZEN YOGURT; DAIRY-BASED FOOD BEVERAGES; DRIED FRUIT AND VEGETABLES; DRIED VEGETABLES; FERMENTED MILK; FOOD PACKAGE COMBINATIONS CONSISTING PRIMARILY OF CHEESE, MEAT AND/OR PROCESSED FRUIT; FRESH UNRIPENED CHEESES; FROZEN FRUITS; FROZEN VEGETABLES; MEAT, FRUIT AND VEGETABLE JELLIES, JAMS; MILK; MILK BASED BEVERAGES CONTAINING FRUIT JUICE; MOLD-RIPENED CHEESE; PICKLED VEGETABLES; PRESERVED FRUIT AND VEGETABLES; PRESERVED FRUITS AND VEGETABLES; PRESERVED VEGETABLES; PROCESSED VEGETABLES; PROCESSED VEGETABLES AND FRUITS; RIPENED CHEESE; SOFT CHEESE; VEGETABLES, INSTANT FROZEN (U.S. CL. 46).

FIRST USE 9-9-2010; IN COMMERCE 10-8-2010.

---

3,941,946. WEIGHT WATCHERS INTERNATIONAL, INC., NEW YORK, NY. SN 77-948,476. PUB. 6-29-2010, FILED 3-2-2010.

**POINTSPLUS**

THE MARK CONSISTS OF STANDARD CHARACTERS WITHOUT CLAIM TO ANY PARTICULAR FONT, STYLE, SIZE, OR COLOR.

FOR FROZEN MEALS CONSISTING PRIMARILY OF MEAT, FISH, POULTRY OR VEGETABLES; YOGURT (U.S. CL. 46).

FIRST USE 1-15-2011; IN COMMERCE 1-15-2011.

---

3,941,957. COLD STAR SALES & LEASING, INC., AKA COLD STAR, MOUNT EPHRAIM, NJ. SN 77-953,894. PUB. 11-2-2010, FILED 3-9-2010.

**CAF Fusion**

THE MARK CONSISTS OF STANDARD CHARACTERS WITHOUT CLAIM TO ANY PARTICULAR FONT, STYLE, SIZE, OR COLOR.

FOR MILK-BASED BEVERAGE CONTAINING COFFEE (U.S. CL. 46).

FIRST USE 10-30-2010; IN COMMERCE 10-30-2010.

**CLASS 29—(Continued).**

3,941,965. MARINER SEAFOOD MARKETING, NEW BEDFORD, MA. SN 77-957,521. PUB. 8-3-2010, FILED 3-12-2010.

**MARSELECT**

THE MARK CONSISTS OF STANDARD CHARACTERS WITHOUT CLAIM TO ANY PARTICULAR FONT, STYLE, SIZE, OR COLOR.

FOR SEAFOOD (U.S. CL. 46).

FIRST USE 12-30-2010; IN COMMERCE 12-30-2010.

---

3,942,055. PERDUE HOLDINGS, INC., WILMINGTON, DE. SN 78-705,936. PUB. 1-1-2008, FILED 9-2-2005.

**SHORT CUTS EXPRESS**

THE MARK CONSISTS OF STANDARD CHARACTERS WITHOUT CLAIM TO ANY PARTICULAR FONT, STYLE, SIZE, OR COLOR.

FOR POULTRY (U.S. CL. 46).

FIRST USE 10-0-2010; IN COMMERCE 10-0-2010.

---

3,942,104. STAVIS SEAFOODS, INC., BOSTON, MA. SN 85-012,896. PUB. 9-7-2010, FILED 4-13-2010.

**Chillfresh**

THE MARK CONSISTS OF STANDARD CHARACTERS WITHOUT CLAIM TO ANY PARTICULAR FONT, STYLE, SIZE, OR COLOR.

FOR SEAFOOD; FISH AND SHELLFISH, NOT LIVE (U.S. CL. 46).

FIRST USE 10-25-2010; IN COMMERCE 10-25-2010.

**CLASS 29—(Continued).**

3,942,130. PASTURELAND, GOODHUE, MN. SN 85-024,441.  
PUB. 10-12-2010, FILED 4-27-2010.

## Farmdog Blue

THE MARK CONSISTS OF STANDARD CHARACTERS WITHOUT CLAIM TO ANY PARTICULAR FONT, STYLE, SIZE, OR COLOR.

NO CLAIM IS MADE TO THE EXCLUSIVE RIGHT TO USE "BLUE", APART FROM THE MARK AS SHOWN.

FOR RAW MILK BLUE CHEESE MADE WITH 100% GRASS-FED COWS' MILK (U.S. CL. 46).

FIRST USE 7-14-2010; IN COMMERCE 7-14-2010.

---

3,942,201. LOERZEL, CHRISTOPHER, BROOKLYN, NY. SN 85-050,759. PUB. 11-9-2010, FILED 5-28-2010.

## That's my Jam!

THE MARK CONSISTS OF STANDARD CHARACTERS WITHOUT CLAIM TO ANY PARTICULAR FONT, STYLE, SIZE, OR COLOR.

NO CLAIM IS MADE TO THE EXCLUSIVE RIGHT TO USE "JAM", APART FROM THE MARK AS SHOWN.

FOR FRUIT-BASED SPREADS; JELLIES AND JAMS (U.S. CL. 46).

FIRST USE 2-1-2009; IN COMMERCE 7-2-2010.

---

3,942,272. PPC MARKETING, LTD., GREELEY, CO. SN 85-071,763. PUB. 11-9-2010, FILED 6-25-2010.

## Quick & Lean

NO CLAIM IS MADE TO THE EXCLUSIVE RIGHT TO USE "LEAN", APART FROM THE MARK AS SHOWN.

THE MARK CONSISTS OF THE WORDING "QUICK & LEAN" IN STYLIZED FORMAT.

FOR POULTRY; FRESH POULTRY; CHICKEN; FRESH CHICKEN (U.S. CL. 46).

FIRST USE 10-1-2010; IN COMMERCE 10-1-2010.

**CLASS 30—STAPLE FOODS****CLASS 30—(Continued).**

3,941,023. VINCENT VAN GOGH CAFE, LLC, ASTORIA, NY. SN 77-139,545. PUB. 9-25-2007, FILED 3-24-2007.

## VINCENT VAN GOGH PREMIUM COFFEE

THE MARK CONSISTS OF STANDARD CHARACTERS WITHOUT CLAIM TO ANY PARTICULAR FONT, STYLE, SIZE, OR COLOR.

NO CLAIM IS MADE TO THE EXCLUSIVE RIGHT TO USE "PREMIUM COFFEE", APART FROM THE MARK AS SHOWN.

FOR BEVERAGES MADE OF COFFEE; CAFFEINE-FREE COFFEE; CHICORY BASED COFFEE SUBSTITUTE; COFFEE; COFFEE; COFFEE BEANS; COFFEE FLAVORED SYRUP USED IN MAKING FOOD BEVERAGES; COFFEE PODS; COFFEE SUBSTITUTES; COFFEE SUBSTITUTES; COFFEE-BASED BEVERAGE CONTAINING MILK; GROUND COFFEE BEANS; INSTANT COFFEE; PREPARED COFFEE AND COFFEE-BASED BEVERAGES; ROASTED COFFEE BEANS; SUGAR-COATED COFFEE BEANS (U.S. CL. 46).

FIRST USE 12-20-2010; IN COMMERCE 12-20-2010.

---

3,941,039. GULF PACIFIC, INC., HOUSTON, TX. SN 77-239,752. PUB. 1-1-2008, FILED 7-26-2007.

simple  
seed  
fuel for change.

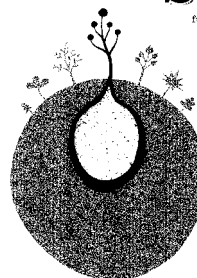

NO CLAIM IS MADE TO THE EXCLUSIVE RIGHT TO USE "SEED", APART FROM THE MARK AS SHOWN.

THE MARK CONSISTS OF THE WORDING "SIMPLE SEED FUEL FOR CHANGE." AND AN EARTH DESIGN CONTAINING CIRCULAR SEED-LIKE DESIGNS GROWING INSIDE AND VARIOUS PLANTS AND TREES ATTACHED TO THE EXTERIOR.

FOR RICE; RICE FLOUR (U.S. CL. 46).

FIRST USE 3-25-2008; IN COMMERCE 1-1-2011.

**CLASS 30—(Continued).**

3,941,064. MEDITCO, INC., DBA PHOENICIA SPECIALTY FOODS, HOUSTON, TX. SN 77-375,943. PUB. 6-3-2008, FILED 1-19-2008.

# ZAHRA'S

THE MARK CONSISTS OF STANDARD CHARACTERS WITHOUT CLAIM TO ANY PARTICULAR FONT, STYLE, SIZE, OR COLOR.

FOR FLOUR, SPICES, SPICE BLENDS, TEA, CHOCOLATE COATED NUTS, SUGAR COATED NUTS, CHOCOLATE, CANDIES, LICORICE, GROUND COFFEE BEANS, FARINA, PROCESSED SEMOLINA, PROCESSED GRAINS, PROCESSED HERBS (U.S. CL. 46).

FIRST USE 2-16-2011; IN COMMERCE 2-16-2011.

---

3,941,105. GURUKRIPA FOODS INC., RICHMOND HILL, NY. SN 77-517,874. PUB. 6-22-2010, FILED 7-9-2008.

# EVEREST

THE MARK CONSISTS OF STANDARD CHARACTERS WITHOUT CLAIM TO ANY PARTICULAR FONT, STYLE, SIZE, OR COLOR.

FOR RICE (U.S. CL. 46).

FIRST USE 12-0-2008; IN COMMERCE 12-0-2008.

---

3,941,266. DANISCO A/S, DK-1001 COPENHAGEN K, DENMARK. SN 77-729,688. PUB. 4-6-2010, FILED 5-5-2009.

# SALTPRO

THE MARK CONSISTS OF STANDARD CHARACTERS WITHOUT CLAIM TO ANY PARTICULAR FONT, STYLE, SIZE, OR COLOR.

FOR NATURAL FLAVORS FOR USE IN REDUCING SODIUM IN FOOD PRODUCTS, NAMELY, FOOD FLAVORINGS OTHER THAN ESSENTIAL OILS (U.S. CL. 46).  
FIRST USE 10-28-2009; IN COMMERCE 10-28-2009.

**CLASS 30—(Continued).**

3,941,553. SK TREE CORPORATION, SANTA MONICA, CA. SN 77-871,427. PUB. 6-1-2010, FILED 11-12-2009.

# GOURMET GUILD

THE MARK CONSISTS OF STANDARD CHARACTERS WITHOUT CLAIM TO ANY PARTICULAR FONT, STYLE, SIZE, OR COLOR.

NO CLAIM IS MADE TO THE EXCLUSIVE RIGHT TO USE "GOURMET", APART FROM THE MARK AS SHOWN.

FOR COFFEE AND TEA-BASED BEVERAGES; ICED TEA AND ICED COFFEE; COCOA; HOT CHOCOLATE; BREAD; PASTRIES; EDIBLE ICE; ICES FOR REFRESHMENT; FLAVORED ICES; ICE CREAM; GELATO; SORBETS; SHERBETS; FROZEN YOGURT; ICE CREAM DRINKS, NAMELY, DRINKS BASED ON GELATO, SORBETS, SHERBETS, FROZEN YOGURT; SANDWICHES; PIZZAS; QUICHES; PANCAKES; CREPES; TARTS; MUFFINS; SCONES; COOKIES; BISCUITS; CAKES; PIES; COFFEE-BASED AND CHOCOLATE BASED SLUSHIES AND GRANITA BEVERAGES; CONFECTIONERY, NAMELY, COCOA-BASED INGREDIENT IN CONFECTIONARY PRODUCTS, CANDY AND FROZEN CONFECTIONS; CRYSTAL SUGAR PIECES, NAMELY, CONFECTIONERY; CHOCOLATE; BEVERAGES MADE OF COCOA, COFFEE, CHOCOLATE OR TEA; SUGAR IN THE NATURE OF CANDY SUGAR FOR FOOD (U.S. CL. 46).

FIRST USE 4-1-2010; IN COMMERCE 7-12-2010.

---

3,941,564. I.M. STEIN, INC., MCHENRY, IL. SN 77-873,572. PUB. 4-20-2010, FILED 11-16-2009.

# HALFTIME

THE MARK CONSISTS OF STANDARD CHARACTERS WITHOUT CLAIM TO ANY PARTICULAR FONT, STYLE, SIZE, OR COLOR.

FOR PIZZA (U.S. CL. 46).

FIRST USE 8-13-2010; IN COMMERCE 10-21-2010.

---

3,941,566. CHENG, JAMES TEE, DBA JC TRADING, PICO RIVERA, CA. SN 77-874,205. PUB. 5-18-2010, FILED 11-17-2009.

# THAI VILLAGE

THE MARK CONSISTS OF STANDARD CHARACTERS WITHOUT CLAIM TO ANY PARTICULAR FONT, STYLE, SIZE, OR COLOR.

**CLASS 30—(Continued).**

NO CLAIM IS MADE TO THE EXCLUSIVE RIGHT TO USE "THAI", APART FROM THE MARK AS SHOWN.  
FOR RICE (U.S. CL. 46).  
FIRST USE 11-15-2010; IN COMMERCE 11-15-2010.

3,941,573. THRIVE FOODS LLC, LINDON, UT. SN 77-876,557.  
PUB. 4-20-2010, FILED 11-19-2009.

**FOOD STORAGE MADE EASY**

THE MARK CONSISTS OF STANDARD CHARACTERS WITHOUT CLAIM TO ANY PARTICULAR FONT, STYLE, SIZE, OR COLOR.

NO CLAIM IS MADE TO THE EXCLUSIVE RIGHT TO USE "FOOD STORAGE", APART FROM THE MARK AS SHOWN.

FOR PROCESSED GRAINS, SAUCES, DESSERT MIX, AND BAKING INGREDIENTS FEATURING BAKING POWDER, SALT, AND SUGAR, STORED IN DRY, FREEZE DRIED, DEHYDRATED FORM, OR CANNED FORM (U.S. CL. 46).

FIRST USE 12-15-2005; IN COMMERCE 12-15-2005.

3,941,593. PBM PRODUCTS, LLC, GORDONSVILLE, VA. SN 77-880,065. PUB. 8-31-2010, FILED 11-24-2009.

**LITTLE WHEELS**

THE MARK CONSISTS OF STANDARD CHARACTERS WITHOUT CLAIM TO ANY PARTICULAR FONT, STYLE, SIZE, OR COLOR.

OWNER OF U.S. REG. NOS. 3,381,945, 3,381,947, AND OTHERS.

NO CLAIM IS MADE TO THE EXCLUSIVE RIGHT TO USE "WHEELS", APART FROM THE MARK AS SHOWN.

FOR FOOD FOR TODDLERS, NAMELY, GRAIN-BASED SNACK FOODS (U.S. CL. 46).

FIRST USE 4-2-2010; IN COMMERCE 4-2-2010.

3,941,602. BELLA SOL FOODS, INC., GLENDALE, CA. SN 77-882,148. PUB. 4-27-2010, FILED 11-30-2009.

**BELLA SOL FOODS**

THE MARK CONSISTS OF STANDARD CHARACTERS WITHOUT CLAIM TO ANY PARTICULAR FONT, STYLE, SIZE, OR COLOR.

**CLASS 30—(Continued).**

NO CLAIM IS MADE TO THE EXCLUSIVE RIGHT TO USE "FOODS", APART FROM THE MARK AS SHOWN.

THE ENGLISH TRANSLATION OF "BELLA SOL" IS "BEAUTIFUL SUN".

FOR MARINADES; SALAD DRESSINGS; SALSA; SAUCES; TORTILLA CHIPS (U.S. CL. 46).

FIRST USE 5-30-2008; IN COMMERCE 5-30-2008.

3,941,629. KALLAMNI, MINA, NEW YORK, NY. AND KALLAMNI, FOUAD, NEW YORK, NY. SN 77-890,745. PUB. 6-1-2010, FILED 12-10-2009.



THE NAME(S), PORTRAIT(S), AND/OR SIGNATURE(S) SHOWN IN THE MARK IDENTIFIES "MINA KALLAMNI", WHOSE CONSENT(S) TO REGISTER IS MADE OF RECORD.

THE MARK CONSISTS OF THE WORDS "MINA HARISSA" WITH A FLOWER DESIGN AS THE DOT FOR THE "I" IN THE WORD "MINA".

THE WORDING "HARISSA" HAS NO MEANING IN A FOREIGN LANGUAGE.

FOR HOT SAUCE (U.S. CL. 46).

FIRST USE 12-30-2010; IN COMMERCE 12-30-2010.

3,941,631. PBM PRODUCTS, LLC, GORDONSVILLE, VA. SN 77-891,622. PUB. 8-31-2010, FILED 12-11-2009.

**LITTLE MUNCHERS**

THE MARK CONSISTS OF STANDARD CHARACTERS WITHOUT CLAIM TO ANY PARTICULAR FONT, STYLE, SIZE, OR COLOR.

OWNER OF U.S. REG. NOS. 3,381,945, 3,381,947, AND OTHERS.

FOR FOOD FOR TODDLERS, NAMELY, GRAIN-BASED SNACK FOODS (U.S. CL. 46).

FIRST USE 4-2-2010; IN COMMERCE 4-2-2010.



**CLASS 30—(Continued).**

3,941,672. PRESTAT LIMITED, LONDON, UNITED KINGDOM. SN 77-897,832. PUB. 5-18-2010, FILED 12-21-2009.

# PRESTAT

THE MARK CONSISTS OF STANDARD CHARACTERS WITHOUT CLAIM TO ANY PARTICULAR FONT, STYLE, SIZE, OR COLOR.

FOR COCOA; CONFECTIONERIES, NAMELY, CHOCOLATES (U.S. CL. 46).

FIRST USE 11-0-2010; IN COMMERCE 11-0-2010.

---

3,941,697. STEVEN VIAT, OAKLAND, CA. SN 77-900,682. PUB. 5-25-2010, FILED 12-24-2009.

# ROYAL BANYAN GOURMET

THE MARK CONSISTS OF STANDARD CHARACTERS WITHOUT CLAIM TO ANY PARTICULAR FONT, STYLE, SIZE, OR COLOR.

NO CLAIM IS MADE TO THE EXCLUSIVE RIGHT TO USE "GOURMET", APART FROM THE MARK AS SHOWN.

FOR SPICES; SUGAR; VINEGAR (U.S. CL. 46).

FIRST USE 1-8-2011; IN COMMERCE 1-8-2011.

---

3,941,704. DONNA DECUNZO TADDEO, LIGHTHOUSE POINT, FL. SN 77-902,629. PUB. 5-18-2010, FILED 12-30-2009.

# LUXE

THE MARK CONSISTS OF STANDARD CHARACTERS WITHOUT CLAIM TO ANY PARTICULAR FONT, STYLE, SIZE, OR COLOR.

FOR NON-ALCOHOLIC AGAVE NECTAR SWEETENER SUBSTITUTE (U.S. CL. 46).

FIRST USE 9-1-2010; IN COMMERCE 9-1-2010.

**CLASS 30—(Continued).**

3,941,747. MORRIS NATIONAL, INC., AZUSA, CA. SN 77-910,516. PUB. 6-1-2010, FILED 1-12-2010.



NO CLAIM IS MADE TO THE EXCLUSIVE RIGHT TO USE "BUBBLE QUBES", APART FROM THE MARK AS SHOWN.

THE COLOR(S) PINK, BLUE AND WHITE IS/ARE CLAIMED AS A FEATURE OF THE MARK.

THE MARK CONSISTS OF A 16-SIDED IRREGULAR SHAPE OUTLINED IN BLUE WITHIN WHICH APPEAR THE WORDS "BUBBLE QUBES" IN STYLIZED WHITE BLOCK LETTERS OUTLINED IN BLUE. THE BACKGROUND COLOR WITHIN THE SHAPE IS PINK. FOUR WHITE HORIZONTAL LINES IN VARYING LENGTHS APPEAR DIRECTLY BELOW THE UPPER HORIZONTAL PORTIONS OF THE SHAPE AND FOUR DARK PINK HORIZONTAL LINES IN VARYING LENGTHS APPEAR DIRECTLY ABOVE THE LOWER HORIZONTAL PORTIONS OF THE SHAPE.

FOR BUBBLE GUM (U.S. CL. 46).

FIRST USE 12-16-2009; IN COMMERCE 12-16-2009.

---

3,941,755. KRAFT FOODS GLOBAL BRANDS LLC, NORTHFIELD, IL. SN 77-911,813. PUB. 5-18-2010, FILED 1-14-2010.

# MAXWELL HOUSE INTERNATIONAL CAFE

THE MARK CONSISTS OF STANDARD CHARACTERS WITHOUT CLAIM TO ANY PARTICULAR FONT, STYLE, SIZE, OR COLOR.

OWNER OF U.S. REG. NOS. 599,153 AND 1,750,312.

NO CLAIM IS MADE TO THE EXCLUSIVE RIGHT TO USE "INTERNATIONAL" AND "CAFE", APART FROM THE MARK AS SHOWN.

FOR COFFEE AND TEA (U.S. CL. 46).

FIRST USE 6-0-2010; IN COMMERCE 6-0-2010.

**CLASS 30—(Continued).**

3,941,763. KEURIG, INCORPORATED, READING, MA. SN 77-912,958. PUB. 6-1-2010, FILED 1-15-2010.



OWNER OF U.S. REG. NOS. 2,417,711 AND 3,104,973. THE MARK CONSISTS OF THE STYLIZED REPRESENTATION OF A CUP AND STAR.

FOR COFFEE, TEA, AND HOT COCOA, SOLD IN SINGLE-SERVING CONTAINERS, FOR USE IN ELECTRIC BREWING MACHINES (U.S. CL. 46).

FIRST USE 11-0-2004; IN COMMERCE 11-0-2004.

3,941,792. JONES, TYRONE D., BALTIMORE, MD. SN 77-918,138. PUB. 5-25-2010, FILED 1-22-2010.



OWNER OF U.S. REG. NO. 3,265,498. NO CLAIM IS MADE TO THE EXCLUSIVE RIGHT TO USE "COOKING" AND "CHEF", APART FROM THE MARK AS SHOWN.

THE NAME(S), PORTRAIT(S), AND/OR SIGNATURE(S) SHOWN IN THE MARK IDENTIFIES TYRONE JONES, WHOSE CONSENT(S) TO REGISTER IS MADE OF RECORD.

**CLASS 30—(Continued).**

THE MARK CONSISTS OF A MALE FACE REPRESENTING TYRONE JONES, WEARING A CAP ON WHICH THE INITIALS "CT" ARE INSCRIBED, IN THE CENTER OF A FIVE-POINTED STAR SUPERIMPOSED OVER A CIRCLE WITH THE WORDS "COOKING TYRONE THE HIP-HOP CHEF" WRAPPING AROUND THE OUTSIDE TOP HALF OF THE CIRCLE.

FOR BARBECUE SAUCE, CHICKEN WING SAUCE, CHILI SAUCE, CARIBBEAN JERK SAUCE, DIPPING SAUCES, HOT SAUCE, MARINADES, PASTA SAUCE, PIZZA SAUCE, SALAD DRESSINGS, SALAD SAUCES, SAUCES, SAUCES FOR BARBECUED MEAT, SEASONED COATING MIXTURES FOR FOOD, SLOPPY JOE SAUCE, SPAGHETTI SAUCE, STEAK SAUCE, TERIYAKI SAUCE, TOMATO SAUCE (U.S. CL. 46).

FIRST USE 3-20-2010; IN COMMERCE 3-20-2010.

3,941,803. MADELAINE CHOCOLATE NOVELTIES, INC., DBA THE MADELAINE CHOCOLATE COMPANY, ROCKAWAY BEACH, NY. SN 77-919,079. PUB. 6-8-2010, FILED 1-25-2010.

# DUEGGS

THE MARK CONSISTS OF STANDARD CHARACTERS WITHOUT CLAIM TO ANY PARTICULAR FONT, STYLE, SIZE, OR COLOR.

FOR CONFECTIONERY PRODUCTS, NAMELY, CHOCOLATES, CANDIES AND FROZEN CONFECTIONS (U.S. CL. 46).

FIRST USE 1-19-2011; IN COMMERCE 1-19-2011.

3,941,817. ASHER HEMP GELATO INC., WASHINGTON, DC. SN 77-920,383. PUB. 6-8-2010, FILED 1-26-2010.

# ZENDULGENCE

THE MARK CONSISTS OF STANDARD CHARACTERS WITHOUT CLAIM TO ANY PARTICULAR FONT, STYLE, SIZE, OR COLOR.

FOR GELATO (U.S. CL. 46).

FIRST USE 10-0-2010; IN COMMERCE 10-0-2010.

**CLASS 30—(Continued).**

3,941,868. CHECKERS DRIVE-IN RESTAURANTS, INC., TAMPA, FL. SN 77-929,180. PUB. 10-26-2010, FILED 2-5-2010.

**BACKWOODS B-B-Q**

THE MARK CONSISTS OF STANDARD CHARACTERS WITHOUT CLAIM TO ANY PARTICULAR FONT, STYLE, SIZE, OR COLOR.

NO CLAIM IS MADE TO THE EXCLUSIVE RIGHT TO USE "B-B-Q", APART FROM THE MARK AS SHOWN. FOR HAMBURGER SANDWICHES (U.S. CL. 46). FIRST USE 2-15-2010; IN COMMERCE 2-15-2010.

---

3,941,873. WM. WRIGLEY JR. COMPANY, CHICAGO, IL. SN 77-930,446. PUB. 6-1-2010, FILED 2-8-2010.

**PRISM**

THE MARK CONSISTS OF STANDARD CHARACTERS WITHOUT CLAIM TO ANY PARTICULAR FONT, STYLE, SIZE, OR COLOR.

FOR CHEWING GUM (U.S. CL. 46). FIRST USE 7-19-2010; IN COMMERCE 7-19-2010.

---

3,941,899. MARQUEZ BROTHERS INTERNATIONAL, INC., SAN JOSE, CA. SN 77-935,135. PUB. 9-28-2010, FILED 2-12-2010.

**EL MEXICANO CHOCO-KID**

THE MARK CONSISTS OF STANDARD CHARACTERS WITHOUT CLAIM TO ANY PARTICULAR FONT, STYLE, SIZE, OR COLOR.

OWNER OF U.S. REG. NOS. 2,086,945, 2,086,964, AND 2,830,245.

THE ENGLISH TRANSLATION OF "EL MEXICANO" IN THE MARK IS "THE MEXICAN". FOR COOKIES (U.S. CL. 46). FIRST USE 12-10-2010; IN COMMERCE 12-10-2010.

**CLASS 30—(Continued).**

3,941,912. RITA'S WATER ICE FRANCHISE COMPANY, LLC, TREVISO, PA. SN 77-939,732. PUB. 11-23-2010, FILED 2-19-2010.

**4TH OF GELATI**

THE MARK CONSISTS OF STANDARD CHARACTERS WITHOUT CLAIM TO ANY PARTICULAR FONT, STYLE, SIZE, OR COLOR.

NO CLAIM IS MADE TO THE EXCLUSIVE RIGHT TO USE "GELATI", APART FROM THE MARK AS SHOWN.

THE ENGLISH TRANSLATION OF "GELATI" IN THE MARK IS ICE CREAMS.

FOR FROZEN CONFECTIONS; FROZEN CUSTARDS; FROZEN YOGURT; FROZEN YOGURT CONFECTIONS; GELATO; ICE CREAM (U.S. CL. 46).

FIRST USE 6-25-2010; IN COMMERCE 6-25-2010.

---

3,941,918. MARS, INCORPORATED, MCLEAN, VA. SN 77-941,423. PUB. 7-13-2010, FILED 2-22-2010.

**LET IT SNOW**

THE MARK CONSISTS OF STANDARD CHARACTERS WITHOUT CLAIM TO ANY PARTICULAR FONT, STYLE, SIZE, OR COLOR.

FOR CANDY (U.S. CL. 46).

FIRST USE 9-30-2010; IN COMMERCE 9-30-2010.

---

3,941,919. MARS, INCORPORATED, MCLEAN, VA. SN 77-941,430. PUB. 7-13-2010, FILED 2-22-2010.

**LIGHT UP THE SEASON**

THE MARK CONSISTS OF STANDARD CHARACTERS WITHOUT CLAIM TO ANY PARTICULAR FONT, STYLE, SIZE, OR COLOR.

FOR CANDY (U.S. CL. 46).

FIRST USE 9-30-2010; IN COMMERCE 9-30-2010.

**CLASS 30—(Continued).**

3,941,935. PERFETTI SALES & MARKETING, INC., COUNTRYSIDE, IL. SN 77-945,514. PUB. 10-5-2010, FILED 2-25-2010.

## SIR CHEWY

THE MARK CONSISTS OF STANDARD CHARACTERS WITHOUT CLAIM TO ANY PARTICULAR FONT, STYLE, SIZE, OR COLOR.

NO CLAIM IS MADE TO THE EXCLUSIVE RIGHT TO USE "CHEWY", APART FROM THE MARK AS SHOWN. FOR CANDY (U.S. CL. 46).

FIRST USE 8-31-2010; IN COMMERCE 8-31-2010.

3,941,947. WEIGHT WATCHERS INTERNATIONAL, INC., NEW YORK, NY. SN 77-948,499. PUB. 6-29-2010, FILED 3-2-2010.

## POINTSPLUS

THE MARK CONSISTS OF STANDARD CHARACTERS WITHOUT CLAIM TO ANY PARTICULAR FONT, STYLE, SIZE, OR COLOR.

FOR FROZEN MEALS CONSISTING PRIMARILY OF PASTA OR RICE; BAGELS; BAKERY PRODUCTS, NAMELY, SWEET BAKERY GOODS; BREAD AND BUNS; ROLLS; BREAKFAST CEREAL; CEREAL-BASED SNACK FOODS; READY TO EAT CEREAL DERIVED FOOD BARS; CHOCOLATE CANDIES; COOKIES; FLOUR-BASED CHIPS; PRETZELS; OATMEAL; ICE CREAM (U.S. CL. 46).

FIRST USE 1-15-2011; IN COMMERCE 1-15-2011.

**CLASS 30—(Continued).**

3,941,949. SWEETS OF OMAN SAOG, SULTANATE OF OMAN, OMAN. SN 77-950,769. PUB. 11-2-2010, FILED 3-4-2010.



NO CLAIM IS MADE TO THE EXCLUSIVE RIGHT TO USE "HONEY", "ECLAIRS", "CARAMELS WITH SWEET HONEY CHOCOLATE CENTRES", "SWEET HONEY CHOCOLATE CENTRES", "FILLED WITH" AND "FILLED" AND THE TERMS AS THEY APPEAR IN ARABIC SCRIPT, APART FROM THE MARK AS SHOWN.

THE COLOR(S) GOLD, YELLOW, METALLIC GOLD, ORANGE, PURPLE, BROWN, LIGHT BROWN, TAN, GREY AND WHITE IS/ARE CLAIMED AS A FEATURE OF THE MARK.

THE MARK CONSISTS OF THE STYLIZED WORD "CHIKO" IN THE COLOR WHITE WITH BROWN BACKGROUND INSIDE AN ELONGATED CIRCLE DESIGN TRIMMED WITH THE COLOR METALLIC GOLD BELOW A FAN LIKE DESIGN IN THE COLOR METALLIC GOLD; THE STYLIZED WORD "HONEY" IN THE COLOR ORANGE, TRIMMED IN THE COLOR GOLD; THE STYLIZED WORD "ECLAIRS" IN THE COLOR PURPLE TRIMMED IN THE COLOR WHITE WITH A METALLIC GOLD BORDER; THE WORDS "CARAMELS" WITH IN THE COLOR PURPLE; THE WORDS "SWEET HONEY CHOCOLATE" IN THE COLOR ORANGE; THE WORD "CENTRES" IN THE COLOR PURPLE; WITH WHAT APPEARS TO BE A DESIGN OF A CHOCOLATE CANDY IN THE COLOR LIGHT BROWN WITH A GOLD AND YELLOW HONEY LIKE SUBSTANCE POURING FROM THE CENTER AND APPEARING TO POUR TO CREATE AN OVAL SWIRL DESIGN OF THE COLORS GOLD AND YELLOW, AND A WHITE BACKGROUND INSIDE AN OVAL DESIGN IN THE COLOR WHITE, AN ELONGATED U-SHAPED WHITE BORDER IN WHICH UNDERNEATH APPEARS A GREY AREA WITH TWO STRAIGHT SIDES THE WORD "SWEET" IN THE COLOR PURPLE; THE WORDS "HONEY CHOCOLATE" IN THE COLOR ORANGE; THE WORD "CENTRES" IN THE COLOR PURPLE INSIDE A CIRCLE DESIGN WITH A WHITE BACKGROUND AND A GOLD BORDER; WITH A TAN WOODEN HONEY DIPPER HAVING HONEY (GOLD) DRIPPING OFF OF IT WITH A WAVE DESIGN IN THE COLORS METALLIC GOLD, WHITE AND ORANGE; AT THE BOTTOM RIGHT OF THE DRAWING IS A SIMILAR SMALLER DESIGN WITH THE SAME ELEMENTS THAT INCLUDE ARABIC SCRIPT TRANSLATION; ALL APPEARING WITH A GOLD BACKGROUND WITH YELLOW HONEY COMB HEXAGON SHAPES, A PURPLE AND METALLIC GOLD STRIPE ABOVE AND A PURPLE AND METALLIC GOLD STRIPE BELOW.

THE ENGLISH TRANSLATION OF ARABIC SCRIPT IN THE MARK IS "CHIKO, HONEY, ECLAIRS, CARAMELS WITH SWEET HONEY CHOCOLATE CENTRES, SWEET HONEY CHOCOLATE CENTRES".

THE NON-LATIN CHARACTERS IN THE MARK TRANSLITERATE TO TSHIKO AND THIS MEANS CHIKO IN ENGLISH; ASAL AND THIS MEANS HONEY IN ENGLISH; EKLEERS AND THIS MEANS ECLAIRS IN ENGLISH; KARAMIL AND THIS MEANS CARAMELS IN ENGLISH; SHOOKOOLATE AND THIS MEANS CHOCOLATE IN ENGLISH; BEHASHWET AND THIS MEANS FILLED WITH IN ENGLISH; HASHWEH AND THIS MEANS FILLING IN ENGLISH.

FOR CHOCOLATE CANDIES AND CONFECTIONERY MADE OF SUGAR (U.S. CL. 46).

FIRST USE 12-19-2009; IN COMMERCE 3-10-2010.

**CLASS 30—(Continued).**

3,942,014. DARLINGTON COOKIE COMPANY, NOBLESVILLE, IN. SN 77-981,141. PUB. 3-3-2009, FILED 10-9-2008.

## APPLEWAYS

THE MARK CONSISTS OF STANDARD CHARACTERS WITHOUT CLAIM TO ANY PARTICULAR FONT, STYLE, SIZE, OR COLOR.

FOR GRANOLA-BASED SNACK BARS; COOKIES; CEREAL-BASED SNACK BARS (U.S. CL. 46).  
FIRST USE 11-9-2010; IN COMMERCE 11-9-2010.

3,942,036. FROG 623 LLC, MERCHANTVILLE, NJ. SN 77-981,348. PUB. 5-18-2010, FILED 12-17-2009.

## THE FLAVOR OF BOLD

THE MARK CONSISTS OF STANDARD CHARACTERS WITHOUT CLAIM TO ANY PARTICULAR FONT, STYLE, SIZE, OR COLOR.

FOR SPICES AND SPICE BLENDS (U.S. CL. 46).  
FIRST USE 9-30-2010; IN COMMERCE 10-30-2010.

3,942,065. TUTTOESPRESSO S.P.A., ORIGGIO (VARESE), ITALY. SN 78-870,428. PUB. 12-4-2007, FILED 4-26-2006.

## TUTTO

THE MARK CONSISTS OF STANDARD CHARACTERS WITHOUT CLAIM TO ANY PARTICULAR FONT, STYLE, SIZE, OR COLOR.

THE FOREIGN WORDING IN THE MARK TRANSLATES INTO ENGLISH AS EVERYTHING.

FOR COFFEE, CAPPUCCINO, TEA, COCOA, BARLEY FLOUR, CAPSULES SHAPED AS INDIVIDUAL PORTIONS FOR USE IN INFUSION, CONTAINING HERB TEAS, GROUND COFFEE, POWDER COFFEE, CAPPUCCINO, ESPRESSO COFFEE, TEA, COCOA AND ARTIFICIAL COFFEE (U.S. CL. 46).  
FIRST USE 11-16-2010; IN COMMERCE 11-16-2010.

**CLASS 30—(Continued).**

3,942,129. GRANDMA LU'S SPICE CABINET, LLC, PLANO, TX. SN 85-024,318. PUB. 10-19-2010, FILED 4-27-2010.



THE NAME "GRANDMA LU" DOES NOT IDENTIFY A LIVING INDIVIDUAL.

THE MARK CONSISTS OF TWO FIGURES WITH A CHILD ON THE LEFT AND TO THE RIGHT AN OLDER WOMEN WITH A HAIR BUN, CENTERED ABOVE THE WORDS "GRANDMA LU'S".

FOR MARINADES; SALAD DRESSINGS; SPICE BLENDS; SPICE RUBS; SPICES (U.S. CL. 46).  
FIRST USE 9-1-2010; IN COMMERCE 9-1-2010.

3,942,132. FRITO-LAY NORTH AMERICA, INC., PLANO, TX. SN 85-024,602. PUB. 8-31-2010, FILED 4-27-2010.



OWNER OF U.S. REG. NOS. 1,599,741, 1,945,450, AND 2,719,306.

NO CLAIM IS MADE TO THE EXCLUSIVE RIGHT TO USE "CHEESY BITES", APART FROM THE MARK AS SHOWN.

THE MARK CONSISTS OF PARTIAL SUNSHINE POSITIONED BETWEEN THE WORDS "CHESTER'S" ABOVE AND "CHEESY BITES" BELOW.

FOR BAGEL CHIPS; CORN-BASED SNACK FOODS; CRACKERS (U.S. CL. 46).  
FIRST USE 2-0-2003; IN COMMERCE 2-0-2003.

**CLASS 30—(Continued).**

3,942,149. RUSSELL STOVER CANDIES, INC., KANSAS CITY, MO. SN 85-033,732. PUB. 10-12-2010, FILED 5-9-2010.



OWNER OF U.S. REG. NOS. 739,454, 1,243,031, AND 3,484,252.

NO CLAIM IS MADE TO THE EXCLUSIVE RIGHT TO USE "NET WT 2 OZ (57)" OR "HANUKKAH" OR "SOLID MILK CHOCOLATE", APART FROM THE MARK AS SHOWN.

THE MARK CONSISTS OF THE DESIGN OF A RECTANGLE REPRESENTING A EIGHTEEN BILLION DOLLAR NOTE, WITH THE WORDS, "RUSSELL STOVER NOTE" WITHIN THE DESIGN OF A RECTANGLE OVER THE WORDS, "HAPPY HANUKKAH", AT THE UPPER MIDDLE EDGE OF THE RECTANGULAR NOTE; "18,000,000,000" WITHIN A ROUND EDGED RECTANGLE WITH A DECORATIVE BORDER APPEARS IN THE FOUR CORNERS SUPERIMPOSED OVER DUAL BRACKET SYMBOLS; THE NUMBER "18" APPEARING TWICE ON THE RIGHT SIDE AND ONCE ON THE LEFT SIDE OF THE RECTANGULAR NOTE; IN THE CENTER OF THE RECTANGULAR NOTE IS A MENORAH; A LEAFY SCROLL PATTERN APPEARS ON THE PERIMETER OF THE RECTANGULAR NOTE; TO THE LEFT OF THE MENORAH, SHIELD OF DAVID OVER THE TERM "18 BILLION" WHICH IS ABOVE THE TERM "NET WT 2 OZ (57 G)"; TO THE RIGHT OF THE MENORAH IS A DREIDEL WITHIN A SEAL; A RECTANGLE WITH DECORATIVE BORDER BELOW THE MENORAH CONTAINING THE WORDS "SOLID MILK CHOCOLATE".

FOR CHOCOLATE BARS (U.S. CL. 46).  
FIRST USE 10-1-2010; IN COMMERCE 10-1-2010.

**CLASS 30—(Continued).**

3,942,162. KORN SNACKS DEL PERU S.A.C., LIMA, PERU. SN 85-040,809. PUB. 11-2-2010, FILED 5-17-2010.



THE COLOR(S) ORANGE, BROWN AND YELLOW IS/ ARE CLAIMED AS A FEATURE OF THE MARK.

THE MARK CONSISTS OF THE TERM "MAIZINGS!" IN STYLIZED LETTERS WITHIN A BROWN SHADED RECTANGLE WITH JAGGED EDGES. THE LETTERS "MAIZINGS!" APPEAR IN THE COLOR YELLOW, EXCEPT THAT THE DOTS IN THE TWO LETTERS "I" AND THE DOT IN THE EXCLAMATION MARK, WHICH APPEAR IN THE FORM OF A CURLED WHORL, APPEAR IN THE COLOR ORANGE. ABOVE THE TERM "MAIZINGS!" AND PROTRUDING PARTIALLY ABOVE THE RECTANGLE IS A STYLIZED CROWNED HEAD OF AN INCA GOD WITH EARRINGS. THE HEAD APPEARS IN THE COLORS YELLOW AND ORANGE. THE BROWN COLOR IN THE RECTANGLE EXTENDS IN A CURVED MANNER AT THE TOP OF THE DRAWING, OUTLINING THE CROWNED HEAD. WITHIN THE RECTANGLE, A RECTANGULAR ORANGE JAGGED LINE, BROKEN TO THE RIGHT AND LEFT OF THE CROWNED HEAD, SURROUNDS THE TERM "MAIZINGS!" AND TAPERS ON BOTH SIDES TOWARD THE LOWER-RIGHT CORNER, WHERE THE TWO TAPERED LINES ARE BROKEN.

FOR CORN-BASED SNACK FOODS (U.S. CL. 46).  
FIRST USE 10-0-2010; IN COMMERCE 10-0-2010.

3,942,153. KORN SNACKS DEL PERU S.A.C., LIMA, PERU. SN 85-037,049. PUB. 11-2-2010, FILED 5-12-2010.

# MAIZINGS!

THE MARK CONSISTS OF STANDARD CHARACTERS WITHOUT CLAIM TO ANY PARTICULAR FONT, STYLE, SIZE, OR COLOR.

FOR CORN-BASED SNACK FOODS (U.S. CL. 46).  
FIRST USE 10-0-2010; IN COMMERCE 10-0-2010.

3,942,187. PENZEYS, LTD., BROOKFIELD, WI. SN 85-047,444. PUB. 10-19-2010, FILED 5-25-2010.

# ARIZONA DREAMING

THE MARK CONSISTS OF STANDARD CHARACTERS WITHOUT CLAIM TO ANY PARTICULAR FONT, STYLE, SIZE, OR COLOR.

FOR SEASONINGS (U.S. CL. 46).  
FIRST USE 6-29-2010; IN COMMERCE 6-29-2010.

**CLASS 30—(Continued).**

3,942,217. TSAKONAS, ATHENA M., DBA LITE YUMMIES, NAPLES, FL. SN 85-053,866. PUB. 11-2-2010, FILED 6-3-2010.



NO CLAIM IS MADE TO THE EXCLUSIVE RIGHT TO USE "LITE", APART FROM THE MARK AS SHOWN.

THE COLOR(S) BLACK AND WHITE IS/ARE CLAIMED AS A FEATURE OF THE MARK.

THE MARK CONSISTS OF BLACK AND WHITE BAR, BLACK BACKGROUND OF BAR WITH STYLIZED WORD "LITE" IN WHITE, WHITE BACKGROUND OF BAR WITH STYLIZED WORD "YUMMIES" IN BLACK, AND THE PHRASE "LESS FAT AND CALORIES NEVER TASTED SO GOOD!!!!".

FOR CAKES; CHOCOLATE-BASED FILLINGS FOR CAKES AND PIES; CUP CAKES; CUSTARD-BASED FILLINGS FOR CAKES AND PIES; DANISH PASTRIES; FROZEN YOGURT PIES AND CAKES; FRUIT PIES; ICED CAKES; PASTRIES; PASTRY; PASTRY CREAM; PETITS FOURS; PIES; SNACK CAKES; SPONGE CAKES (U.S. CL. 46).

FIRST USE 9-1-2010; IN COMMERCE 1-1-2011.

3,942,219. ACOSTA, FRANCISCO MARTIN, QUITO, ECUADOR. SN 85-053,932. PUB. 11-9-2010, FILED 6-3-2010.

**KIWA**

THE MARK CONSISTS OF STANDARD CHARACTERS WITHOUT CLAIM TO ANY PARTICULAR FONT, STYLE, SIZE, OR COLOR.

THE WORDING "KIWA" HAS NO MEANING IN A FOREIGN LANGUAGE.

FOR GRANOLA-BASED SNACK BARS; BOILED CORN; PROCESSED CORN; GRANOLA SNACKS; CORN CHIPS; STEAMED CORN KERNELS (U.S. CL. 46).

FIRST USE 5-0-2010; IN COMMERCE 5-0-2010.

**CLASS 30—(Continued).**

3,942,236. VM PRODUCTS & MARKET DEVELOPMENT, INC., SAN JUAN, PUERTO RICO. SN 85-058,665. PUB. 11-2-2010, FILED 6-9-2010.



NO CLAIM IS MADE TO THE EXCLUSIVE RIGHT TO USE "BITES", APART FROM THE MARK AS SHOWN.

THE STIPPLING IS FOR SHADING PURPOSES.

THE MARK CONSISTS OF THE WORDS "BREAK BITES" IN STYLIZED LETTERS NEXT TO THE FACE OF A DUCK WITH ITS ARMS EXTENDED, WEARING A HAT, A SHIRT AND A WHISTLE, ALL INSIDE A HORIZONTALLY POSITIONED OVAL.

FOR ALIMENTARY PASTA; APPLE FRITTERS; APPLE TURNOVERS; ARRANGEMENTS OF CUT FRUIT COMPRISED OF FRESH FRUITS CUT INTO FLOWER SHAPES AND AT LEAST PARTIALLY COATED WITH CHOCOLATE; BAGEL CHIPS; BAGEL HOLES; BAGELS; BAGUETTES; BAKERY DESSERTS; BAKERY GOODS; BAKERY GOODS AND DESSERT ITEMS, NAMELY, CHEESECAKES FOR RETAIL AND WHOLESALE DISTRIBUTION AND CONSUMPTION ON OR OFF THE PREMISES; BAKERY PRODUCTS; BAKERY PRODUCTS, NAMELY, SWEET BAKERY GOODS; BANANA FRITTERS; BISCOTTI; BISCUITS; BISCUITS AND BREAD; BOILED SWEETS; BONBONS; BONBONS MADE OF SUGAR; BREAD; BREAD AND PASTRY; BREAD CRUMBS; BREAD ROLLS; BREAD STICKS; BREAK-FAST CEREALS; BROWN SUGAR; BROWNIE MIXES; BRUSCHETTA-TOPPED BREAD; BUNS; BURRITOS; CAFFEINE-FREE COFFEE; CAKE MIXES, NAMELY, CAKE BASES; CALZONES; CANDIES; CANDY; CANDY DECORATIONS FOR CAKES; CANDY FOR FOOD; CANDY SPRINKLES; CANDY WITH CARAMEL; CARAMEL TOPPING FOR ICE CREAM; CEREAL BASED ENERGY BARS; CEREAL BASED SNACK FOOD; CHOCOLATE BARK CONTAINING GROUND COFFEE BEANS; CHOCOLATE BARS; CHOCOLATE CANDIES; CHOCOLATE COVERED COCOA NIBS; CHOCOLATE COVERED FRUIT; CHOCOLATE COVERED NUTS; CHOCOLATE COVERED POPCORN; CHOCOLATE MOUSSE; CHOCOLATE TRUFFLES; CHOCOLATE-BASED BEVERAGES WITH MILK; CHOCOLATE-BASED FILLINGS FOR CAKES AND PIES; CHOCOLATES CONTAINING NUTRIENTS; CINNAMON POWDER; CONFECTIONERY FOR DECORATING CHRISTMAS TREES; COOKED RICE; COOKIE DOUGH; COOKIE MIXES; COOKIES; CRAB BOIL; CREPES; DIVINITY; DONUTS; DOUGH-ENROBED FOODS CONSISTING OF A DOUGH-BASED WRAPPER WITH FILLINGS CONSISTING PRIMARILY OF MEATS, POULTRY, FISH, FRUITS AND VEGETABLES AND CHEESE; DOUGH-ENROBED FOODS CONSISTING OF A DOUGH-BASED WRAPPER WITH FILLINGS CONSISTING PRIMARILY OF PASTA AND RICE; DOUGHNUT HOLES; ENERGY MINTS; EXTRACTS USED AS FLAVORING; EXTRUDED CORN SNACKS; FERMENTED HOT PEPPER PASTE FOR USE AS A SEASONING; FOOD LEAVENING AGENTS; FREEZABLE LIQUID FOR USE IN MAKING FROZEN CONFECTIONS; FROSTINGS; FROZEN APPETIZERS

**CLASS 30—(Continued).**

CONSISTING PRIMARILY OF CORNMEAL; FROZEN CASHEW-BASED DESSERTS; FROZEN CONFECTIONS, NAMELY, FREEZER POPS; FROZEN FLAVORED WATERS; FRUCTOSE FOR FOOD; FRUIT BREADS; FRUIT CAKES; FRUIT PASTE FOR FLAVORING OF FOOD; FRUIT TEAS; FRUIT TURNOVERS; GATEAUX; GELATO; GINGER PASTE FOR USE AS A SEASONING; GRAIN-BASED SNACK FOODS; GRANOLA; GRANOLA SNACKS; GUM SWEETS; MONOSODIUM GLUTAMATE USED AS A FLAVOR ENHANCER FOR FOOD; MUFFIN MIXES; MUFFINS; NOUGAT; PASTA-WRAPPINGS FOR GYOZA; PASTRIES; PIMIENTO USED AS A CONDIMENT; PINEAPPLE FRITTERS; PITA; RICE; SLOPPY JOE SEASONING MIX; SNACK FOOD CHEWS MADE PRIMARILY FROM BROWN RICE SYRUP; SPICES AND ICE; SUGAR AND SUGAR SUBSTITUTES; SUGAR WAFERS; SUGAR-COATED COFFEE BEANS; SUGAR-FREE CHEWING GUM; SUGARED BEANS (AMA-NAT-TO); SUGARLESS CANDIES; SUGARLESS CHEWING GUM; SWEETMEAT MADE OF SESAME OIL (U.S. CL. 46).

FIRST USE 1-22-2011; IN COMMERCE 1-22-2011.

---

3,942,240. SHEREE BREKKE, SAN LUIS OBISPO, CA. AND TOBIAS S. BREKKE, SAN LUIS OBISPO, CA. SN 85-061,076. PUB. 10-26-2010, FILED 6-11-2010.

**WINGFOOT**

THE MARK CONSISTS OF STANDARD CHARACTERS WITHOUT CLAIM TO ANY PARTICULAR FONT, STYLE, SIZE, OR COLOR.

FOR BREAKFAST CEREALS; BROWNIE MIXES; COOKIE MIXES (U.S. CL. 46).

FIRST USE 4-7-2010; IN COMMERCE 7-22-2010.

---

3,942,241. SHEREE BREKKE, SAN LUIS OBISPO, CA. AND TOBIAS S. BREKKE, SAN LUIS OBISPO, CA. SN 85-061,101. PUB. 10-26-2010, FILED 6-11-2010.



THE MARK CONSISTS OF THE WORD "WINGFOOT" WHERE THE LETTER "I" CONSISTS OF A HUMAN FOOT WITH A WING ATTACHED AT THE ANKLE, WITH A FEW INCHES OF LEG SHOWING.

FOR BREAKFAST CEREALS; BROWNIE MIXES; COOKIE MIXES (U.S. CL. 46).

FIRST USE 4-7-2010; IN COMMERCE 7-22-2010.

**CLASS 31—NATURAL AGRICULTURAL PRODUCTS****CLASS 31—(Continued).**

3,941,006. CULPEPER FARMERS' COOPERATIVE INC., CULPEPER, VA. SN 76-703,531. PUB. 11-23-2010, FILED 6-28-2010.

**PACE-MAKER EPIC HORSE FEED**

THE MARK CONSISTS OF STANDARD CHARACTERS WITHOUT CLAIM TO ANY PARTICULAR FONT, STYLE, SIZE, OR COLOR.

NO CLAIM IS MADE TO THE EXCLUSIVE RIGHT TO USE "HORSE FEED", APART FROM THE MARK AS SHOWN.

FOR HORSE FEED (U.S. CLS. 1 AND 46).

FIRST USE 8-1-2010; IN COMMERCE 8-1-2010.

---

3,941,463. PETRA PET, INC., DBA PETRAPPORT, NORTH BERGEN, NJ. SN 77-827,795. PUB. 2-16-2010, FILED 9-16-2009.

**LIVER TOPS**

THE MARK CONSISTS OF STANDARD CHARACTERS WITHOUT CLAIM TO ANY PARTICULAR FONT, STYLE, SIZE, OR COLOR.

OWNER OF U.S. REG. NO. 3,400,660.

NO CLAIM IS MADE TO THE EXCLUSIVE RIGHT TO USE "LIVER", APART FROM THE MARK AS SHOWN.

FOR CONSUMABLE PET CHEWS (U.S. CLS. 1 AND 46).

FIRST USE 5-14-2009; IN COMMERCE 5-14-2009.

---

3,941,464. PETRA PET, INC., DBA PETRAPPORT, NORTH BERGEN, NJ. SN 77-827,817. PUB. 2-16-2010, FILED 9-16-2009.

**DUCK TOPS**

THE MARK CONSISTS OF STANDARD CHARACTERS WITHOUT CLAIM TO ANY PARTICULAR FONT, STYLE, SIZE, OR COLOR.

OWNER OF U.S. REG. NO. 3,400,660.

NO CLAIM IS MADE TO THE EXCLUSIVE RIGHT TO USE "DUCK", APART FROM THE MARK AS SHOWN.

FOR CONSUMABLE PET CHEWS (U.S. CLS. 1 AND 46).

FIRST USE 5-14-2009; IN COMMERCE 5-14-2009.



**CLASS 31—(Continued).**

3,941,534. BOHEMIA NURSERY LLC, WEST OLIVE, MI. SN 77-864,580. PUB. 4-13-2010, FILED 11-4-2009.

## Smart Choice

THE MARK CONSISTS OF STANDARD CHARACTERS WITHOUT CLAIM TO ANY PARTICULAR FONT, STYLE, SIZE, OR COLOR.

FOR LIVE PLANTS (U.S. CLS. 1 AND 46),  
FIRST USE 9-1-2010; IN COMMERCE 9-1-2010.

3,941,577. ROCKY MOUNTAIN VETERINARY NEUROLOGY, LLC, ENGLEWOOD, CO. SN 77-877,842. PUB. 7-6-2010, FILED 11-20-2009.



THE COLOR(S) RED, BLACK, GRAY, TAN, BROWN AND WHITE IS/ARE CLAIMED AS A FEATURE OF THE MARK.

THE MARK CONSISTS OF THE WORDING "WAG PAK" IN BLACK WITH A DESIGN OF A BONE IN GRAY, BLACK AND WHITE AS PART OF THE LETTER "A"; TO THE LEFT OF THE WORDING A DESIGN OF A DOG IN TAN AND BLACK WITH A BLACK AND WHITE NOSE, A BROWN EYE AND A RED TONGUE HANGING OUT WITH A WAGGING TAIL SIGNIFIED BY THREE CURVY LINES; AND A RED HEART ABOVE THE LETTER "G" OF THE TERM "WAG".

FOR DOG TREATS, DOG BISCUITS, DOG FOOD, DIGESTIBLE CHEWING BONES FOR DOGS (U.S. CLS. 1 AND 46).

FIRST USE 11-1-2010; IN COMMERCE 11-1-2010.

**CLASS 31—(Continued).**

3,941,650. EXPORTALIZAS MEXICANAS S.A DE C.V., CULIACAN, SINALOA, MEXICO. SN 77-894,547. PUB. 7-20-2010, FILED 12-16-2009.



THE COLOR(S) YELLOW, GREEN, LIGHT GREEN AND GRAY IS/ARE CLAIMED AS A FEATURE OF THE MARK.

THE MARK CONSISTS OF YELLOW SEMI CIRCLE ON TOP, TWO LEAVES BELOW THE CIRCLE, ONE IN LIGHT GREEN WITH GRAY MIDDLE AND THE OTHER IN GREEN WITH LIGHT GREEN MIDDLE, THE GREEN WORDING "EXPORMEX" UNDERLINED IN YELLOW APPEARING BELOW THE LEAVES, AND THE GREEN WORDING "CONFIABILIDAD, SIEMPRE" APPEARING BELOW THE YELLOW LINE.

THE ENGLISH TRANSLATION OF "CONFIABILIDAD, SIEMPRE" IN THE MARK IS RELIABLE ALWAYS.

FOR FRESH FRUIT AND VEGETABLES (U.S. CLS. 1 AND 46).

FIRST USE 1-7-2010; IN COMMERCE 1-7-2010.

3,941,736. PETERSON, ROBERT NEAL, HARPERS FERRY, WV. SN 77-908,604. PUB. 5-18-2010, FILED 1-10-2010.

## Allegheny

THE MARK CONSISTS OF STANDARD CHARACTERS WITHOUT CLAIM TO ANY PARTICULAR FONT, STYLE, SIZE, OR COLOR.

FOR LIVING TREES, NAMELY, THE 2-9 VARIETY OF ASIMINA TRILOBA (NORTH AMERICAN PAWPAW TREE) RAW FRUITS (U.S. CLS. 1 AND 46).

FIRST USE 4-30-2007; IN COMMERCE 4-30-2007.

**CLASS 31—(Continued).**

3,941,737. PETERSON, ROBERT NEAL, HARPERS FERRY, WV. SN 77-908,605. PUB. 9-21-2010, FILED 1-10-2010.

# Potomac

THE MARK CONSISTS OF STANDARD CHARACTERS WITHOUT CLAIM TO ANY PARTICULAR FONT, STYLE, SIZE, OR COLOR.

FOR LIVING TREES, NAMELY, THE 4-2 VARIETY OF ASIMINA TRILOBA (NORTH AMERICAN PAWPAW TREE) RAW FRUITS FROM THE ASIMINA TRILOBA SPECIES (NORTH AMERICAN PAWPAW) (U.S. CLS. 1 AND 46).

FIRST USE 4-30-2007; IN COMMERCE 4-30-2007.

---

3,941,738. PETERSON, ROBERT NEAL, HARPERS FERRY, WV. SN 77-908,607. PUB. 5-18-2010, FILED 1-10-2010.

# Wabash

THE MARK CONSISTS OF STANDARD CHARACTERS WITHOUT CLAIM TO ANY PARTICULAR FONT, STYLE, SIZE, OR COLOR.

FOR LIVING TREES, NAMELY, THE 1-7-2 VARIETY OF ASIMINA TRILOBA (NORTH AMERICAN PAWPAW TREE) RAW FRUITS (U.S. CLS. 1 AND 46).

FIRST USE 4-30-2007; IN COMMERCE 4-30-2007.

---

3,941,754. MERRICK PET CARE, INC., AMARILLO, TX. SN 77-911,650. PUB. 4-27-2010, FILED 1-14-2010.

## NUTRITION FOR THE BODY! COMFORT FOR THE SOUL!

THE MARK CONSISTS OF STANDARD CHARACTERS WITHOUT CLAIM TO ANY PARTICULAR FONT, STYLE, SIZE, OR COLOR.

OWNER OF U.S. REG. NO. 3,158,263.  
FOR PET FOOD (U.S. CLS. 1 AND 46).  
FIRST USE 3-25-2010; IN COMMERCE 3-25-2010.

**CLASS 31—(Continued).**

3,941,770. LAND O'LAKES PURINA FEED LLC, SHOREVEIW, MN. SN 77-913,964. PUB. 6-8-2010, FILED 1-18-2010.

# INFINIA HOLISTIC

THE MARK CONSISTS OF STANDARD CHARACTERS WITHOUT CLAIM TO ANY PARTICULAR FONT, STYLE, SIZE, OR COLOR.

NO CLAIM IS MADE TO THE EXCLUSIVE RIGHT TO USE "HOLISTIC", APART FROM THE MARK AS SHOWN. FOR PET FOOD (U.S. CLS. 1 AND 46).

FIRST USE 5-12-2010; IN COMMERCE 5-12-2010.

---

3,941,786. THE HARTZ MOUNTAIN CORPORATION, SECAUCUS, NJ. SN 77-916,301. PUB. 6-1-2010, FILED 1-20-2010.



OWNER OF U.S. REG. NOS. 3,124,059, 3,124,060, AND 3,385,999.

THE MARK CONSISTS OF A CIRCLE WITHIN A CIRCLE. IN THE INNER CIRCLE ARE THE WORDS "RAISED IN HARTZ THE HEARTLAND". THE WORD "HARTZ" IN THE INNER CIRCLE IS WITHIN A SQUARE. IN THE OUTER CIRCLE ARE THE WORDS "AMERICA'S" ON THE TOP PART AND THE WORD "PRIME" ON THE BOTTOM PART OF CIRCLE. THESE WORDS ARE SEPARATED BY THREE STAR DESIGNS ON EACH SIDE.

FOR EDIBLE CHEWS FOR DOGS (U.S. CLS. 1 AND 46).

FIRST USE 3-15-2010; IN COMMERCE 3-15-2010.

**CLASS 31—(Continued).**

3,941,884. SOCIO X INC., NEW YORK, NY. SN 77-931,428.  
PUB. 6-22-2010, FILED 2-9-2010.

# poochclub

THE MARK CONSISTS OF STANDARD CHARACTERS WITHOUT CLAIM TO ANY PARTICULAR FONT, STYLE, SIZE, OR COLOR.

FOR CAT FOOD; DOG FOOD; PET BEVERAGES; PET FOOD; PET TREATS (U.S. CLS. 1 AND 46).  
FIRST USE 1-0-1991; IN COMMERCE 9-21-2010.

3,941,887. FOREMAN JR. HERBERT M., DBA ADVANTAGE SEED COMPANY, RAYMOND, MS. SN 77-931,849. PUB. 8-10-2010, FILED 2-9-2010.



NO CLAIM IS MADE TO THE EXCLUSIVE RIGHT TO USE "GRADE", APART FROM THE MARK AS SHOWN.

THE MARK CONSISTS OF THE WORDING "BUBBA'S BAIT PREMIUM GRADE PLOT SEED" AND THE DESIGN OF A MALE HUNTER HAVING A BEARD AND A CAP HOLDING A SHOTGUN. THE WORDING "BUBBA'S BAIT" IS POSITIONED WITHIN AN ARC DESIGN, WITH CONCENTRIC CIRCLE DESIGNS TO BOTH SIDE OF "BAIT" AND THE WORDING "PREMIUM GRADE" WITHIN A RECTANGULAR DESIGN. THE WORDING "PLOT SEED" IS BENEATH THE RECTANGLE.

FOR AGRICULTURAL SEEDS; CROP SEEDS; PLANT SEEDS; SEEDS FOR AGRICULTURAL PURPOSES; SOWING SEEDS; WHEAT SEED; WILDLIFE SEED MIXTURES (U.S. CLS. 1 AND 46).

FIRST USE 9-1-1999; IN COMMERCE 4-16-2010.

3,942,186. APODACA, GINNY, SEATTLE, WA. SN 85-046,900.  
PUB. 11-2-2010, FILED 5-25-2010.

## JOIE DE VIVRE WAGGIN' POOCH BAKERY

THE MARK CONSISTS OF STANDARD CHARACTERS WITHOUT CLAIM TO ANY PARTICULAR FONT, STYLE, SIZE, OR COLOR.

**CLASS 31—(Continued).**

NO CLAIM IS MADE TO THE EXCLUSIVE RIGHT TO USE "POOCH BAKERY", APART FROM THE MARK AS SHOWN.

THE ENGLISH TRANSLATION OF "JOIE DE VIVRE" IS "JOY OF LIFE".

FOR DOG FOOD; DOG TREATS (U.S. CLS. 1 AND 46).  
FIRST USE 7-1-2010; IN COMMERCE 7-1-2010.

3,942,253. FARMERS FEED MILL, INC., LEXINGTON, KY.  
SN 85-065,464. PUB. 11-16-2010, FILED 6-17-2010.

# POIZE

THE MARK CONSISTS OF STANDARD CHARACTERS WITHOUT CLAIM TO ANY PARTICULAR FONT, STYLE, SIZE, OR COLOR.

FOR HORSE FEED (U.S. CLS. 1 AND 46).  
FIRST USE 7-1-2010; IN COMMERCE 7-1-2010.

3,942,284. SUNKIST GROWERS, INC., SHERMAN OAKS, CA. SN 85-074,681. PUB. 11-30-2010, FILED 6-30-2010.

## SUNKIST SMILES

THE MARK CONSISTS OF STANDARD CHARACTERS WITHOUT CLAIM TO ANY PARTICULAR FONT, STYLE, SIZE, OR COLOR.

OWNER OF U.S. REG. NOS. 72,087, 3,078,555, AND OTHERS.

FOR FRESH FRUIT (U.S. CLS. 1 AND 46).  
FIRST USE 11-20-2010; IN COMMERCE 11-20-2010.

3,942,324. KAYTEE PRODUCTS INCORPORATED, CHILTON, WI. SN 85-113,829. PUB. 11-9-2010, FILED 8-23-2010.

## KAYTEE SPRING BLEND

THE MARK CONSISTS OF STANDARD CHARACTERS WITHOUT CLAIM TO ANY PARTICULAR FONT, STYLE, SIZE, OR COLOR.

OWNER OF U.S. REG. NOS. 1,440,780, 3,088,673, AND OTHERS.

**CLASS 31—(Continued).**

NO CLAIM IS MADE TO THE EXCLUSIVE RIGHT TO USE "SPRING BLEND", APART FROM THE MARK AS SHOWN. FOR WILD BIRD FOOD (U.S. CLS. 1 AND 46). FIRST USE 2-1-2011; IN COMMERCE 2-1-2011.

**CLASS 32—(Continued).**

3,941,069. JOYOUNG COMPANY LIMITED, SHANDONG PROVINCE, CHINA. SN 77-408,060. PUB. 5-25-2010, FILED 2-27-2008.

**CLASS 32—LIGHT BEVERAGES**

3,940,988. BRADEN, MICHAEL T., CHANDLER, AZ. SN 76-696,865. PUB. 9-22-2009, FILED 4-14-2009.

# SOYO

**MARGARITA SENSATIONS**

THE MARK CONSISTS OF STANDARD CHARACTERS WITHOUT CLAIM TO ANY PARTICULAR FONT, STYLE, SIZE, OR COLOR.

NO CLAIM IS MADE TO THE EXCLUSIVE RIGHT TO USE "MARGARITA", APART FROM THE MARK AS SHOWN.

FOR NON-ALCOHOLIC COCKTAIL MIXES FOR MAKING MARGARITAS (U.S. CLS. 45, 46 AND 48). FIRST USE 8-8-2009; IN COMMERCE 8-8-2009.

THE MARK CONSISTS OF STANDARD CHARACTERS WITHOUT CLAIM TO ANY PARTICULAR FONT, STYLE, SIZE, OR COLOR.

FOR FRUIT JUICES; SOFT DRINKS; ENERGY DRINKS; SOFT DRINKS FLAVORED WITH TEA; SODA WATER; NON-ALCOHOLIC BEVERAGES, NAMELY, CARBONATED BEVERAGES; BEER (U.S. CLS. 45, 46 AND 48).

FIRST USE 1-31-2008; IN COMMERCE 2-27-2008.

3,941,000. FIGUEROA MOUNTAIN BREWING, LLC, VENTURA, CA. SN 76-701,235. PUB. 7-6-2010, FILED 1-19-2010.

3,941,245. PAIGE LIMITED CORP., PANAMA, PANAMA. SN 77-698,419. PUB. 7-28-2009, FILED 3-25-2009.

**FIGUEROA MOUNTAIN BREWING**

THE MARK CONSISTS OF STANDARD CHARACTERS WITHOUT CLAIM TO ANY PARTICULAR FONT, STYLE, SIZE, OR COLOR.

NO CLAIM IS MADE TO THE EXCLUSIVE RIGHT TO USE "BREWING", APART FROM THE MARK AS SHOWN. FOR BEERS (U.S. CLS. 45, 46 AND 48).

FIRST USE 12-1-2010; IN COMMERCE 12-1-2010.



3,941,065. CELESTIAL SEASONINGS, INC., BOULDER, CO. SN 77-377,043. PUB. 6-3-2008, FILED 1-22-2008.

NO CLAIM IS MADE TO THE EXCLUSIVE RIGHT TO USE "CALIFORNIA", APART FROM THE MARK AS SHOWN.

THE COLOR(S) YELLOW, ORANGE AND BLACK IS/ARE CLAIMED AS A FEATURE OF THE MARK.

THE MARK CONSISTS OF A LEAF LIKE FIGURE INSIDE OF WHICH APPEAR THE WORDS "CALIFORNIA ICE COOL" IN STYLIZED LETTERS. THE WORD "CALIFORNIA" APPEARS PROMINENTLY IN THE DESIGN. THE WORDS "ICE COOL" APPEAR IN MUCH SMALLER SIZE. A LEAF APPEARS ABOVE THE LETTERS "ORNI" OF THE WORD "CALIFORNIA". THE COLORS YELLOW AND ORANGE APPEAR IN THE BIG LEAF LIKE DESIGN AS WELL AS IN THE SMALL LEAF. THE COLOR BLACK APPEARS IN THE WORDS "CALIFORNIA ICECOOL" AS WELL AS IN THE OUTER BORDER OF THE LEAF LIKE DESIGN.

FOR CONCENTRATES, SYRUPS OR POWDERS USED IN THE PREPARATION OF SOFT DRINKS; FRUIT DRINKS AND FRUIT JUICES; MINERAL AND AERATED WATERS; NON-ALCOHOLIC BEVERAGES CONTAINING FRUIT JUICES; NON-ALCOHOLIC FRUIT JUICE BEVERAGES; PREPARATIONS FOR MAKING BEVERAGES, NAMELY, FRUIT DRINKS; SPARKLING WATER; SYRUPS FOR MAKING BEVERAGES (U.S. CLS. 45, 46 AND 48).

FIRST USE 12-31-2000; IN COMMERCE 9-30-2009.



OWNER OF U.S. REG. NOS. 1,252,372, 3,113,174, AND OTHERS.

NO CLAIM IS MADE TO THE EXCLUSIVE RIGHT TO USE "100% NATURAL TEAS" AND "SEASONINGS", APART FROM THE MARK AS SHOWN.

FOR BEVERAGES, NAMELY, SOFT DRINKS, SOFT DRINK MIXES, POWDERS OR CONCENTRATES FOR MAKING SOFT DRINKS (U.S. CLS. 45, 46 AND 48).

FIRST USE 3-0-2010; IN COMMERCE 3-0-2010.

**CLASS 32—(Continued).**

3,941,568. AQUA TECHNOLOGY SYSTEMS, LLC, WESTON, WI. SN 77-875,734. PUB. 4-20-2010, FILED 11-18-2009.

## pHerformance

THE MARK CONSISTS OF STANDARD CHARACTERS WITHOUT CLAIM TO ANY PARTICULAR FONT, STYLE, SIZE, OR COLOR.

FOR HIGH PH DRINKING WATER (U.S. CLS. 45, 46 AND 48).

FIRST USE 7-31-2009; IN COMMERCE 7-31-2009.

**CLASS 32—(Continued).**

3,941,647. SUPER BAKERY INC, PITTSBURGH, PA. SN 77-894,394. PUB. 5-11-2010, FILED 12-16-2009.

## VERMONTADE

THE MARK CONSISTS OF STANDARD CHARACTERS WITHOUT CLAIM TO ANY PARTICULAR FONT, STYLE, SIZE, OR COLOR.

FOR FRUIT DRINKS; SPORTS DRINKS (U.S. CLS. 45, 46 AND 48).

FIRST USE 12-3-2010; IN COMMERCE 12-3-2010.

3,941,599. ROSENBERG, GERALD, BOCA RATON, FL. AND ROSENBERG, KENNETH, NEW YORK, NY. SN 77-881,766. PUB. 4-27-2010, FILED 11-29-2009.

## Citi Soda Flavors of the City

THE MARK CONSISTS OF STANDARD CHARACTERS WITHOUT CLAIM TO ANY PARTICULAR FONT, STYLE, SIZE, OR COLOR.

NO CLAIM IS MADE TO THE EXCLUSIVE RIGHT TO USE "SODA" & "FLAVORS", APART FROM THE MARK AS SHOWN.

FOR NON-ALCOHOLIC BEVERAGES, NAMELY, CARBONATED BEVERAGES (U.S. CLS. 45, 46 AND 48).

FIRST USE 1-20-2011; IN COMMERCE 1-20-2011.

3,941,674. THE MASTERS OF BEVERAGES, LLC, CORONA, CA. SN 77-898,056. PUB. 5-11-2010, FILED 12-21-2009.

## LIGHTER SPIDER

THE MARK CONSISTS OF STANDARD CHARACTERS WITHOUT CLAIM TO ANY PARTICULAR FONT, STYLE, SIZE, OR COLOR.

FOR ENERGY DRINKS (U.S. CLS. 45, 46 AND 48).

FIRST USE 5-19-2010; IN COMMERCE 5-19-2010.

3,941,646. SUPER BAKERY INC, PITTSBURGH, PA. SN 77-894,388. PUB. 5-11-2010, FILED 12-16-2009.

## DAKOTA ADE

THE MARK CONSISTS OF STANDARD CHARACTERS WITHOUT CLAIM TO ANY PARTICULAR FONT, STYLE, SIZE, OR COLOR.

FOR FRUIT DRINKS; SPORTS DRINKS (U.S. CLS. 45, 46 AND 48).

FIRST USE 12-3-2010; IN COMMERCE 12-3-2010.

3,941,685. ROESCH, DEBRA, PENDLETON, OR. SN 77-899,108. PUB. 5-18-2010, FILED 12-22-2009.



THE MARK CONSISTS OF THE STYLIZED INITIALS "RBCO" IN A SHADED CIRCLE IN THE CENTER OF OUTLINED DEER ANTLERS. THE BLACK RECTANGLE IN THE BACKGROUND IS FOR CONTRAST PURPOSES ONLY AND IS NOT CLAIMED AS A FEATURE OF THE MARK.

FOR BEER (U.S. CLS. 45, 46 AND 48).

FIRST USE 8-19-2010; IN COMMERCE 8-19-2010.

**CLASS 32—(Continued).**

3,941,708. KRAFT FOODS GLOBAL BRANDS LLC, NORTH-FIELD, IL. SN 77-903,021. PUB. 5-18-2010, FILED 12-30-2009.

**WATER YOUR BODY**

THE MARK CONSISTS OF STANDARD CHARACTERS WITHOUT CLAIM TO ANY PARTICULAR FONT, STYLE, SIZE, OR COLOR.

FOR BEVERAGES, NAMELY, SOFT DRINKS, MIXES IN THE NATURE OF CONCENTRATES, SYRUPS OR POWDERS USED IN THE PREPARATION OF MAKING SOFT DRINKS; POWDERS, SYRUPS OR CONCENTRATES FOR MAKING SOFT DRINKS (U.S. CLS. 45, 46 AND 48).

FIRST USE 12-29-2009; IN COMMERCE 12-29-2009.

3,941,764. ATLANTIC RICHFIELD COMPANY, WARRENVILLE, IL. SN 77-913,122. PUB. 5-25-2010, FILED 1-15-2010.

**GOOD STUFF**

THE MARK CONSISTS OF STANDARD CHARACTERS WITHOUT CLAIM TO ANY PARTICULAR FONT, STYLE, SIZE, OR COLOR.

OWNER OF U.S. REG. NOS. 2,219,487 AND 2,235,119. FOR BOTTLED WATER (U.S. CLS. 45, 46 AND 48). FIRST USE 4-26-2010; IN COMMERCE 4-26-2010.

3,941,945. WORLD TRIATHLON CORPORATION, TAMPA, FL. SN 77-948,259. PUB. 6-29-2010, FILED 3-2-2010.

**IRONMAN PERFORM**

THE MARK CONSISTS OF STANDARD CHARACTERS WITHOUT CLAIM TO ANY PARTICULAR FONT, STYLE, SIZE, OR COLOR.

OWNER OF U.S. REG. NOS. 1,258,881, 2,869,852, AND OTHERS.

NO CLAIM IS MADE TO THE EXCLUSIVE RIGHT TO USE "PERFORM", APART FROM THE MARK AS SHOWN.

FOR FRUIT JUICES AND ENERGY DRINKS CONTAINING NUTRITIONAL SUPPLEMENTS, WHICH ARE MARKETED IN ASSOCIATION WITH CONTESTS CONSISTING OF SWIMMING, BIKING AND RUNNING (U.S. CLS. 45, 46 AND 48).

FIRST USE 5-2-2010; IN COMMERCE 6-8-2010.

**CLASS 32—(Continued).**

3,942,003. MOUNTAIN CREST SRL, MAXWELL, CHRIST CHURCH, BARBADOS. SN 77-970,104. PUB. 8-17-2010, FILED 3-26-2010.

**AXE HEAD**

THE MARK CONSISTS OF STANDARD CHARACTERS WITHOUT CLAIM TO ANY PARTICULAR FONT, STYLE, SIZE, OR COLOR.

FOR BEER (U.S. CLS. 45, 46 AND 48). FIRST USE 9-0-2003; IN COMMERCE 9-0-2003.

3,942,007. ARCADIA DAIRY FARMS, INC., ARDEN, NC. SN 77-981,004. PUB. 2-23-2010, FILED 9-29-2009.

**ZOO BOO**

THE MARK CONSISTS OF STANDARD CHARACTERS WITHOUT CLAIM TO ANY PARTICULAR FONT, STYLE, SIZE, OR COLOR.

FOR NON-ALCOHOLIC BEVERAGES, NAMELY, FRUIT DRINKS (U.S. CLS. 45, 46 AND 48).

FIRST USE 11-15-2010; IN COMMERCE 11-15-2010.

3,942,074. THE CABRON FAMILY HOLDINGS, INC., LOS ANGELES, CA. SN 78-973,330. PUB. 10-9-2007, FILED 9-13-2006.

**Cabron Cerveza**

THE MARK CONSISTS OF STANDARD CHARACTERS WITHOUT CLAIM TO ANY PARTICULAR FONT, STYLE, SIZE, OR COLOR.

NO CLAIM IS MADE TO THE EXCLUSIVE RIGHT TO USE "CERVEZA", APART FROM THE MARK AS SHOWN.

THE ENGLISH TRANSLATION OF THE WORD "CABRON CERVEZA" IN THE MARK IS GOAT BEER.

FOR BEERS AND ALES, BEER-BASED COOLERS, BLACK BEER IN THE NATURE OF TOASTED-MALT BEER, BREWED MALT-BASED ALCOHOLIC BEVERAGE IN THE NATURE OF A BEER, COFFEE-FLAVORED BEER, EXTRACTS OF HOPS FOR MAKING BEER, GINGER BEER, HOP EXTRACTS FOR MANUFACTURING BEER, IMITATION BEER, MALT BEER, MALT LIQUOR IN THE NATURE OF BEER OR ALE, NON-ALCOHOLIC BEER, PALE BEER, PORTER BEER, LAGER BEER, LIGHT BEER (U.S. CLS. 45, 46 AND 48).

FIRST USE 6-10-2010; IN COMMERCE 10-25-2010.

**CLASS 32—(Continued).**

3,942,080. MILLERCOORS LLC, CHICAGO, IL. SN 85-001,645.  
PUB. 7-13-2010, FILED 3-30-2010.

**BET ON TASTE**

THE MARK CONSISTS OF STANDARD CHARACTERS WITHOUT CLAIM TO ANY PARTICULAR FONT, STYLE, SIZE, OR COLOR.  
FOR BEER (U.S. CLS. 45, 46 AND 48).  
FIRST USE 3-1-2010; IN COMMERCE 3-1-2010.

3,942,127. MILLERCOORS LLC, CHICAGO, IL. SN 85-024,192.  
PUB. 8-31-2010, FILED 4-27-2010.

**EVERY GAME'S A REASON TO  
CELEBRATE**

THE MARK CONSISTS OF STANDARD CHARACTERS WITHOUT CLAIM TO ANY PARTICULAR FONT, STYLE, SIZE, OR COLOR.  
FOR BEER (U.S. CLS. 45, 46 AND 48).  
FIRST USE 4-1-2010; IN COMMERCE 4-1-2010.

3,942,133. MAGIC HAT IP, LLC, BURLINGTON, VT. SN 85-025,226. PUB. 9-28-2010, FILED 4-28-2010.

**OURTOBERFEST**

THE MARK CONSISTS OF STANDARD CHARACTERS WITHOUT CLAIM TO ANY PARTICULAR FONT, STYLE, SIZE, OR COLOR.  
FOR BEER, ALE AND LAGER (U.S. CLS. 45, 46 AND 48).  
FIRST USE 8-15-2010; IN COMMERCE 8-15-2010.

**CLASS 33—WINES AND SPIRITS****CLASS 33—(Continued).**

3,941,032. OLIVEIRA, LUIS FERREIRA, NORTON, MA. SN 77-217,021. PUB. 12-4-2007, FILED 6-27-2007.

**BLACK RABBIT**

THE MARK CONSISTS OF STANDARD CHARACTERS WITHOUT CLAIM TO ANY PARTICULAR FONT, STYLE, SIZE, OR COLOR.  
FOR WINES; LIQUOR; BRANDY; LIQUEURS (U.S. CLS. 47 AND 49).  
FIRST USE 1-27-2011; IN COMMERCE 2-4-2011.

3,941,094. TRUTH SPIRITS, LLC, AUSTIN, TX. SN 77-497,405.  
PUB. 11-11-2008, FILED 6-12-2008.

**Tenneyson**

THE MARK CONSISTS OF STANDARD CHARACTERS WITHOUT CLAIM TO ANY PARTICULAR FONT, STYLE, SIZE, OR COLOR.  
FOR ALCOHOLIC BEVERAGES EXCEPT BEERS (U.S. CLS. 47 AND 49).  
FIRST USE 1-12-2011; IN COMMERCE 1-20-2011.

3,941,197. HWA RYUN JUGA CO., LTD., GYEONGGI-DO, REPUBLIC OF KOREA. SN 77-649,271. PUB. 1-12-2010, FILED 1-14-2009.

**HWAYO**

THE MARK CONSISTS OF STANDARD CHARACTERS WITHOUT CLAIM TO ANY PARTICULAR FONT, STYLE, SIZE, OR COLOR.  
FOR RUM, PERRY, BUPJU, SOJU, YAG-JU, SAKE, TAK-JU, STRAWBERRY WINE, TONIC LIQUOR FLAVORED WITH PLUM EXTRACTS, WILD GRAPES WINE, KIRSCH, VERMOUTH, VODKA, BRANDY, CIDER, CHAMPAGNE, ABSINTHE, WHISKY, CITRON WINE, GINSENG, COCKTAILS, WINE, GIN, WINE COOLERS, COMPOUND RICE WINE, ALCOHOLIC EXTRACTS, BITTERS, ARAK, CURACAO, LIQUEURS, ANISE, FRUIT EXTRACTS, APERITIFS (U.S. CLS. 47 AND 49).  
FIRST USE 5-22-2007; IN COMMERCE 5-22-2007.

**CLASS 33—(Continued).**

3,941,223. DOLIUM S.A., MENDOZA, ARGENTINA. SN 77-669,441. PUB. 6-9-2009, FILED 2-12-2009.

# BEATUM

THE MARK CONSISTS OF STANDARD CHARACTERS WITHOUT CLAIM TO ANY PARTICULAR FONT, STYLE, SIZE, OR COLOR.

FOR WINE (U.S. CLS. 47 AND 49).  
FIRST USE 12-15-2010; IN COMMERCE 12-15-2010.

---

3,941,254. PAPPAS, MICHAEL ALEXANDER, TEMPE, AZ. SN 77-717,020. PUB. 9-1-2009, FILED 4-19-2009.

## Silversword Hawaiian Rum

THE MARK CONSISTS OF STANDARD CHARACTERS WITHOUT CLAIM TO ANY PARTICULAR FONT, STYLE, SIZE, OR COLOR.

NO CLAIM IS MADE TO THE EXCLUSIVE RIGHT TO USE "HAWAIIAN RUM", APART FROM THE MARK AS SHOWN.

FOR LIQUOR; LIQUOR AND LIQUEUR BEVERAGES, NAMELY, RUM COCKTAIL (U.S. CLS. 47 AND 49).  
FIRST USE 10-1-2010; IN COMMERCE 2-1-2011.

---

3,941,276. BRIGADOON VINEYARD, LLC, EUGENE, OR. SN 77-743,057. PUB. 9-29-2009, FILED 5-22-2009.



# BRIGADOON

THE COLOR(S) REDDISH BROWN AND BROWN IS/ARE CLAIMED AS A FEATURE OF THE MARK.

THE MARK CONSISTS OF A REDDISH BROWN CIRCLE WITH REDDISH BROWN VINES WITHIN THE CIRCLE AND THE WORD MARK "BRIGADOON" SITUATED BELOW THE CIRCLE IN BROWN FONT.

FOR GRAPE WINE; RED WINE; TABLE WINES; WHITE WINE; WINE (U.S. CLS. 47 AND 49).  
FIRST USE 11-16-2009; IN COMMERCE 11-16-2009.

**CLASS 33—(Continued).**

3,941,361. COLLE DI BOASI S.A., MENDOZA, ARGENTINA. SN 77-780,771. PUB. 6-1-2010, FILED 7-14-2009.

# BENVENUTO DE LA SERNA MIL PIEDRAS

THE MARK CONSISTS OF STANDARD CHARACTERS WITHOUT CLAIM TO ANY PARTICULAR FONT, STYLE, SIZE, OR COLOR.

OWNER OF U.S. REG. NO. 3,703,559.  
THE ENGLISH TRANSLATION OF "MIL PIEDRAS" IN THE MARK IS ONE THOUSAND STONES. THE ENGLISH TRANSLATION OF "BENVENUTO" IN THE MARK IS WELCOME. THE WORDING "DE LA SERNA" HAS NO MEANING IN A FOREIGN LANGUAGE.

FOR WINES (U.S. CLS. 47 AND 49).  
FIRST USE 12-1-2010; IN COMMERCE 12-1-2010.

---

3,941,423. THE WINE GROUP LLC, TRACY, CA. SN 77-803,322. PUB. 3-30-2010, FILED 8-12-2009.

# SANTIAGO STATION

THE MARK CONSISTS OF STANDARD CHARACTERS WITHOUT CLAIM TO ANY PARTICULAR FONT, STYLE, SIZE, OR COLOR.

NO CLAIM IS MADE TO THE EXCLUSIVE RIGHT TO USE "SANTIAGO", APART FROM THE MARK AS SHOWN.

FOR WINE (U.S. CLS. 47 AND 49).  
FIRST USE 12-6-2010; IN COMMERCE 12-6-2010.

---

3,941,440. F.L.NAVARRO LTD, DBA THE ARTISAN COLLECTION, BROOKLYN, NY. SN 77-812,380. PUB. 2-9-2010, FILED 8-25-2009.

# TRES OSOS

THE MARK CONSISTS OF STANDARD CHARACTERS WITHOUT CLAIM TO ANY PARTICULAR FONT, STYLE, SIZE, OR COLOR.

THE ENGLISH TRANSLATION OF "TRES OSOS" IN THE MARK IS "THREE BEARS".

FOR WINES (U.S. CLS. 47 AND 49).  
FIRST USE 8-6-2009; IN COMMERCE 10-2-2009.



**CLASS 33—(Continued).**

3,941,504. F. L. NAVARRO LTD, DBA THE ARTISAN COLLECTION, BROOKLYN, NY. SN 77-852,414. PUB. 2-16-2010, FILED 10-20-2009.

**DOS POR CUATRO**

THE MARK CONSISTS OF STANDARD CHARACTERS WITHOUT CLAIM TO ANY PARTICULAR FONT, STYLE, SIZE, OR COLOR.

THE ENGLISH TRANSLATION OF "DOS POR CUATRO" IN THE MARK IS TWO BY FOUR.

FOR WINES (U.S. CLS. 47 AND 49).

FIRST USE 11-2-2009; IN COMMERCE 11-2-2009.

3,941,544. WINE SCOUT INTERNATIONAL, NAPA, CA. SN 77-868,043. PUB. 2-2-2010, FILED 11-9-2009.

**JURISPRUDENCE**

THE MARK CONSISTS OF STANDARD CHARACTERS WITHOUT CLAIM TO ANY PARTICULAR FONT, STYLE, SIZE, OR COLOR.

FOR ALCOHOLIC BEVERAGES EXCEPT BEERS (U.S. CLS. 47 AND 49).

FIRST USE 3-31-2010; IN COMMERCE 3-31-2010.

3,941,598. DIAMOND HONG, INC., BROOKLYN, NY. SN 77-881,551. PUB. 5-4-2010, FILED 11-27-2009.

金  
標

THE MARK CONSISTS OF TWO NON-LATIN CHARACTERS.

THE ENGLISH TRANSLATION OF "JIN," "BIAO" IN THE MARK IS GOLD SIGN.

THE NON-LATIN CHARACTERS IN THE MARK TRANSLITERATE TO "JIN," "BIAO" AND THIS MEANS GOLD SIGN IN ENGLISH.

FOR WINES AND LIQUEURS (U.S. CLS. 47 AND 49).  
FIRST USE 12-13-2010; IN COMMERCE 12-13-2010.

**CLASS 33—(Continued).**

3,941,621. NICKLAUS COMPANIES, LLC, NORTH PALM BEACH, FL. SN 77-887,915. PUB. 10-26-2010, FILED 12-7-2009.

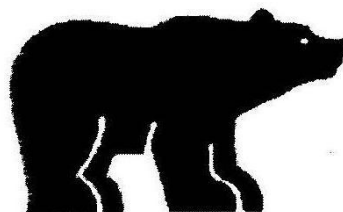

OWNER OF U.S. REG. NOS. 1,845,165 AND 1,862,097.

THE MARK CONSISTS OF BEAR DESIGN.

FOR WINE (U.S. CLS. 47 AND 49).

FIRST USE 9-30-2010; IN COMMERCE 9-30-2010.

3,941,632. VINOS DE LOS HEREDEROS DEL MARQUÉS DE RISCAL, S.A., ELCIEGO, SPAIN. SN 77-891,866. PUB. 8-31-2010, FILED 12-11-2009.



OWNER OF U.S. REG. NOS. 825,409 AND 2,806,906.

NO CLAIM IS MADE TO THE EXCLUSIVE RIGHT TO USE "VIÑA" AND " ELCIEGO (ESPAÑA) RIOJA DENOMINACIÓN DE ORIGEN CALIFICADA EMBOTELLADO POR BODEGA" AND "S.L. E.CIEGO (ESPAÑA) R.E.N. 308-VI PRODUCT OF SPAIN 13% VOL CONT 75CL"., APART FROM THE MARK AS SHOWN.

THE COLOR(S) BLACK, WHITE, GOLD AND BLUE IS/ ARE CLAIMED AS A FEATURE OF THE MARK.

THE MARK CONSISTS OF THE WORDS "VIÑA COLLADA" IN BLACK, "BY MARQUÉS DE RISCAL" IN GOLD, "ELCIEGO (ESPAÑA) RIOJA DENOMINACIÓN DE ORIGEN CALIFICADA EMBOTELLADO POR BODEGA DE LOS HEREDEROS DEL MARQUES DE RISCAL, S.L. ELCIEGO (ESPAÑA) R.E.N. 308-VI PRODUCT OF SPAIN 13% VOL CONT 75CL." IN BLACK. IN THE CENTER OF THE UPPER PORTION OF THE MARK IS A CROWN ABOVE A BOX CONTAINING GRAPES IN GOLD. IN THE LOWER PORTION OF THE MARK ARE A GRAPE FIELD AND A TREE IN BLACK. IN THE CENTER OF THE LOWER PORTION OF THE MARK IS A STAMP WITH THE TERM RIOJA IN GOLD. THE MARK IS OUTLINED IN BLUE, GOLD AND WHITE AND THE BACKGROUND IS WHITE.

**CLASS 33—(Continued).**

THE ENGLISH TRANSLATION OF "VIÑA COLLADA; MARQUES DE RISCAL, S.L. ESPAÑA; DENOMINACION DE ORIGEN CALIFICADA RIOJA; EMBOTELLADO POR BODEGAS DE LOS HERIDEROS DEL MARQUEÉS DE RISCAL, S.L., ESPAÑA" IN THE MARK IS "MOUNTAIN PASS VINEYARD; MARQUÉS DE RISCAL, A LIMITED LIABILITY COMPANY OF SPAIN; QUALIFIED TO CLAIM DESIGNATION OF ORIGIN IN RIOJA, SPAIN; BOTTLED FOR THE WINERY OF THE HEIRS OF MARQUES DE RISCAL, A LIMITED LIABILITY COMPANY OF SPAIN".

FOR ALCOHOLIC BEVERAGES EXCEPT BEERS (U.S. CLS. 47 AND 49).

FIRST USE 10-29-2009; IN COMMERCE 8-11-2010.

3,941,665. SUTTER HOME WINERY, INC., ST. HELENA, CA. SN 77-897,203. PUB. 4-27-2010, FILED 12-18-2009.

## VINESTONE

THE MARK CONSISTS OF STANDARD CHARACTERS WITHOUT CLAIM TO ANY PARTICULAR FONT, STYLE, SIZE, OR COLOR.

FOR ALCOHOLIC BEVERAGES EXCEPT BEERS (U.S. CLS. 47 AND 49).

FIRST USE 12-20-2010; IN COMMERCE 12-20-2010.

3,941,690. W.J. DEUTSCH & SONS LTD., WHITE PLAINS, NY. SN 77-899,606. PUB. 5-11-2010, FILED 12-22-2009.

## ROCK VIEW

THE MARK CONSISTS OF STANDARD CHARACTERS WITHOUT CLAIM TO ANY PARTICULAR FONT, STYLE, SIZE, OR COLOR.

FOR WINE (U.S. CLS. 47 AND 49).

FIRST USE 11-8-2010; IN COMMERCE 11-8-2010.

3,941,793. WAL-MART STORES, INC., BENTONVILLE, AR. SN 77-918,180. PUB. 6-1-2010, FILED 1-22-2010.

## MEMBER'S MARK

THE MARK CONSISTS OF STANDARD CHARACTERS WITHOUT CLAIM TO ANY PARTICULAR FONT, STYLE, SIZE, OR COLOR.

**CLASS 33—(Continued).**

OWNER OF U.S. REG. NOS. 2,579,025, 2,579,036, AND OTHERS.

FOR ALCOHOLIC BEVERAGES EXCEPT BEERS (U.S. CLS. 47 AND 49).

FIRST USE 12-31-2009; IN COMMERCE 12-31-2009.

3,941,829. LAKE RIDGE VINEYARDS, LLC, SAINT HELENA, CA. SN 77-921,541. PUB. 9-21-2010, FILED 1-27-2010.

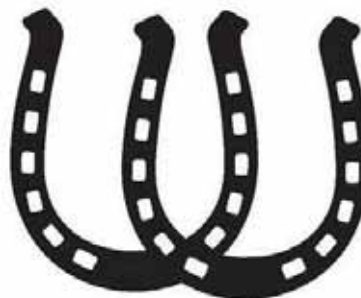

THE MARK CONSISTS OF TWO OVERLAPPING HORSESHOES FACING UPRIGHT WITH SIX NAIL MARKS ON EACH SIDE.

FOR WINE (U.S. CLS. 47 AND 49).

FIRST USE 8-31-2008; IN COMMERCE 8-31-2008.

3,941,921. KOBRAND CORPORATION, PURCHASE, NY. SN 77-942,415. PUB. 5-25-2010, FILED 2-23-2010.

## RED SPLASH

THE MARK CONSISTS OF STANDARD CHARACTERS WITHOUT CLAIM TO ANY PARTICULAR FONT, STYLE, SIZE, OR COLOR.

NO CLAIM IS MADE TO THE EXCLUSIVE RIGHT TO USE "RED", APART FROM THE MARK AS SHOWN.

FOR WINE (U.S. CLS. 47 AND 49).

FIRST USE 11-0-2010; IN COMMERCE 11-0-2010.

**CLASS 33—(Continued).**

3,941,924. BANFI PRODUCTS CORPORATION, OLD BROOKVILLE, NY. SN 77-943,511. PUB. 6-15-2010, FILED 2-24-2010.

## PUZZLE TREE

THE MARK CONSISTS OF STANDARD CHARACTERS WITHOUT CLAIM TO ANY PARTICULAR FONT, STYLE, SIZE, OR COLOR.

FOR WINES (U.S. CLS. 47 AND 49).  
FIRST USE 7-28-2010; IN COMMERCE 9-15-2010.

3,942,047. PATRON SPIRITS INTERNATIONAL AG, SCHAFFHAUSEN, SWITZERLAND. SN 77-981,486. PUB. 6-1-2010, FILED 1-14-2010.



OWNER OF U.S. REG. NOS. 2,942,978, 3,491,521, AND OTHERS.

THE MARK CONSISTS OF THE WORDS "PATRON" AND "CITRONGE" AND A PICTURE OF AN ORANGE BELOW THE WORD "CITRONGE", ALL WITH A BORDER AROUND IT.

THE ENGLISH TRANSLATION OF "PATRON" IS BOSS; THE WORD "CITRONGE" HAS NO MEANING IN A FOREIGN LANGUAGE.

FOR ALCOHOLIC BEVERAGES EXCEPT BEERS; LIQUEURS (U.S. CLS. 47 AND 49).  
FIRST USE 5-0-2010; IN COMMERCE 5-0-2010.

**CLASS 33—(Continued).**

3,942,089. J VINEYARDS & WINERY, L.P., HEALDSBURG, CA. SN 85-005,490. PUB. 6-29-2010, FILED 4-2-2010.



OWNER OF U.S. REG. NOS. 1,735,792 AND 3,515,428.  
THE COLOR(S) YELLOW IS/ARE CLAIMED AS A FEATURE OF THE MARK.

THE MARK CONSISTS OF THE LETTER "J" IN STYLIZED YELLOW FORM.

FOR WINES (U.S. CLS. 47 AND 49).  
FIRST USE 12-31-1987; IN COMMERCE 12-31-1987.

3,942,152. CANTINA SOCIALE COOPERATIVA DI SOAVE - SOCIETA' AGRICOLA COOPERATIVA, SOAVE (VR), ITALY. SN 85-035,385. PUB. 9-21-2010, FILED 5-11-2010.

## RE MIDAS

THE MARK CONSISTS OF STANDARD CHARACTERS WITHOUT CLAIM TO ANY PARTICULAR FONT, STYLE, SIZE, OR COLOR.

THE ENGLISH TRANSLATION OF "RE MIDAS" IN THE MARK IS "KING MIDAS".

FOR WINES (U.S. CLS. 47 AND 49).  
FIRST USE 9-15-2010; IN COMMERCE 9-15-2010.

3,942,156. TERRAVANT WINE COMPANY, LLC, SANTA BARBARA, CA. SN 85-039,254. PUB. 10-19-2010, FILED 5-14-2010.

## CHOPHOUSE

THE MARK CONSISTS OF STANDARD CHARACTERS WITHOUT CLAIM TO ANY PARTICULAR FONT, STYLE, SIZE, OR COLOR.

FOR WINE; WINES (U.S. CLS. 47 AND 49).  
FIRST USE 8-30-2010; IN COMMERCE 8-30-2010.

**CLASS 33—(Continued).**

3,942,171. KLEIN FOODS, INC., DBA RODNEY STRONG VINEYARDS, HEALDSBURG, CA. SN 85-043,719. PUB. 10-19-2010, FILED 5-20-2010.

**EARTHSTONE**

THE MARK CONSISTS OF STANDARD CHARACTERS WITHOUT CLAIM TO ANY PARTICULAR FONT, STYLE, SIZE, OR COLOR.

FOR WINES (U.S. CLS. 47 AND 49).  
FIRST USE 7-8-2010; IN COMMERCE 7-8-2010.

3,942,177. INFINITY WINERY CORPORATION, DBA CALIFORNIA INFINITY WINERY, NEWPORT BEACH, CA. SN 85-045,402. PUB. 10-19-2010, FILED 5-21-2010.

**California Infinity**

THE MARK CONSISTS OF STANDARD CHARACTERS WITHOUT CLAIM TO ANY PARTICULAR FONT, STYLE, SIZE, OR COLOR.

NO CLAIM IS MADE TO THE EXCLUSIVE RIGHT TO USE "CALIFORNIA", APART FROM THE MARK AS SHOWN.

FOR PORT WINES; RED WINE; RED WINES; SPARKLING FRUIT WINE; SPARKLING GRAPE WINE; SPARKLING WINES; STILL WINES; SWEET WINES; TABLE WINES; WHITE WINE; WINE; WINES; WINES AND FORTIFIED WINES; WINES AND LIQUEURS; WINES AND SPARKLING WINES (U.S. CLS. 47 AND 49).  
FIRST USE 8-24-2010; IN COMMERCE 8-24-2010.

3,942,221. CAPTURE WINE BRANDS LLC, HEALDSBURG, CA. SN 85-054,258. PUB. 11-2-2010, FILED 6-3-2010.

**FLEURON**

THE MARK CONSISTS OF STANDARD CHARACTERS WITHOUT CLAIM TO ANY PARTICULAR FONT, STYLE, SIZE, OR COLOR.

THE ENGLISH TRANSLATION OF "FLEURON" IN THE MARK IS "FLOWERET".

FOR WINES (U.S. CLS. 47 AND 49).  
FIRST USE 10-20-2010; IN COMMERCE 10-20-2010.

**CLASS 33—(Continued).**

3,942,262. THE WINE GROUP LLC, TRACY, CA. SN 85-067,966. PUB. 11-16-2010, FILED 6-21-2010.

**LOTTO MOSCATO**

THE MARK CONSISTS OF STANDARD CHARACTERS WITHOUT CLAIM TO ANY PARTICULAR FONT, STYLE, SIZE, OR COLOR.

NO CLAIM IS MADE TO THE EXCLUSIVE RIGHT TO USE "MOSCATO", APART FROM THE MARK AS SHOWN. THE ENGLISH TRANSLATION OF THE WORD "MOSCATO" IN THE MARK IS "MUSCAT".

FOR WINE (U.S. CLS. 47 AND 49).  
FIRST USE 1-31-2011; IN COMMERCE 1-31-2011.

3,942,264. K & G IMPORTS LLC, EL PRADO, NM. SN 85-069,703. PUB. 11-16-2010, FILED 6-23-2010.

**Dire Wolf**

THE MARK CONSISTS OF STANDARD CHARACTERS WITHOUT CLAIM TO ANY PARTICULAR FONT, STYLE, SIZE, OR COLOR.

FOR LIQUOR (U.S. CLS. 47 AND 49).  
FIRST USE 12-1-2010; IN COMMERCE 1-1-2011.

3,942,268. INFINITY WINERY CORPORATION, DBA CALIFORNIA INFINITY WINERY, NEWPORT BEACH, CA. SN 85-071,113. PUB. 10-19-2010, FILED 6-24-2010.

**California Infinity Forever**

THE MARK CONSISTS OF STANDARD CHARACTERS WITHOUT CLAIM TO ANY PARTICULAR FONT, STYLE, SIZE, OR COLOR.

NO CLAIM IS MADE TO THE EXCLUSIVE RIGHT TO USE "CALIFORNIA", APART FROM THE MARK AS SHOWN.

FOR RED WINE; RED WINES; SPARKLING FRUIT WINE; SPARKLING GRAPE WINE; SPARKLING WINES; STILL WINES; TABLE WINES; WHITE WINE; WINE; WINES AND LIQUEURS; WINES AND SPARKLING WINES (U.S. CLS. 47 AND 49).

FIRST USE 8-24-2010; IN COMMERCE 8-24-2010.

**CLASS 33—(Continued).**

3,942,311. KLEIN FOODS, INC. DBA RODNEY STRONG VINEYARDS, HEALDSBURG, CA. SN 85-091,630. PUB. 10-19-2010, FILED 7-23-2010.

**LANDING PLACE**

THE MARK CONSISTS OF STANDARD CHARACTERS WITHOUT CLAIM TO ANY PARTICULAR FONT, STYLE, SIZE, OR COLOR.

FOR WINES (U.S. CLS. 47 AND 49).  
FIRST USE 9-2-2010; IN COMMERCE 9-2-2010.

**CLASS 34—SMOKERS' ARTICLES**

3,941,202. ALTERNATIVE SOLUTIONS, LLC, HUNTINGTON BEACH, CA. SN 77-653,061. PUB. 12-15-2009, FILED 1-20-2009.

**SMOKELESS SOLUTION**

THE MARK CONSISTS OF STANDARD CHARACTERS WITHOUT CLAIM TO ANY PARTICULAR FONT, STYLE, SIZE, OR COLOR.

NO CLAIM IS MADE TO THE EXCLUSIVE RIGHT TO USE "SMOKELESS", APART FROM THE MARK AS SHOWN.

FOR ELECTRONIC CIGARETTES FOR USE AS AN ALTERNATIVE TO TRADITIONAL CIGARETTES (U.S. CLS. 2, 8, 9 AND 17).  
FIRST USE 8-0-2010; IN COMMERCE 8-0-2010.

3,942,054. HOFFMAN HOUSE CIGAR & TOBACCO LLC, CHICAGO, IL. SN 78-691,332. PUB. 8-22-2006, FILED 8-12-2005.

**HOFFMAN HOUSE**

THE MARK CONSISTS OF STANDARD CHARACTERS WITHOUT CLAIM TO ANY PARTICULAR FONT, STYLE, SIZE, OR COLOR.

NO CLAIM IS MADE TO THE EXCLUSIVE RIGHT TO USE "HOUSE", APART FROM THE MARK AS SHOWN.

FOR CIGARS (U.S. CLS. 2, 8, 9 AND 17).  
FIRST USE 10-0-2006; IN COMMERCE 10-0-2006.

**CLASS 34—(Continued).****SERVICE MARKS****CLASS 35—ADVERTISING AND BUSINESS**

3,940,978. LOVE IT LLC, EAST AMHERST, NY. SN 76-647,855. PUB. 11-13-2007, FILED 10-3-2005.

**ONENIAGARA**

THE MARK CONSISTS OF STANDARD CHARACTERS WITHOUT CLAIM TO ANY PARTICULAR FONT, STYLE, SIZE, OR COLOR.

FOR PROMOTING TOURISM AND ECONOMIC DEVELOPMENT IN THE BUFFALO NIAGARA REGION (U.S. CLS. 100, 101 AND 102).

FIRST USE 9-1-2010; IN COMMERCE 9-1-2010.

3,940,990. CRAZY TAILS LLC, BUFFALO GROVE, IL. SN 76-697,371. PUB. 10-20-2009, FILED 5-13-2009.

**CRAZY TAILS**

THE MARK CONSISTS OF STANDARD CHARACTERS WITHOUT CLAIM TO ANY PARTICULAR FONT, STYLE, SIZE, OR COLOR.

FOR DISTRIBUTORSHIPS IN THE FIELD OF PET FOOD AND PET SUPPLIES VIA RETAIL STORES AND THE INTERNET; ONLINE RETAIL STORE SERVICES FEATURING PET FOOD AND PET SUPPLIES (U.S. CLS. 100, 101 AND 102).

FIRST USE 1-4-2011; IN COMMERCE 1-4-2011.

3,941,056. BAND KITTY, LLC, BRECKENRIDGE, CO. SN 77-334,669. PUB. 11-18-2008, FILED 11-20-2007.

**BAND KITTY**

THE MARK CONSISTS OF STANDARD CHARACTERS WITHOUT CLAIM TO ANY PARTICULAR FONT, STYLE, SIZE, OR COLOR.

NO CLAIM IS MADE TO THE EXCLUSIVE RIGHT TO USE "BAND", APART FROM THE MARK AS SHOWN.

FOR REPRESENTATION AND MANAGEMENT OF PERFORMING ARTISTS, INCLUDING SINGERS, MUSICIANS AND COMEDIANS; ONLINE ENTERTAINMENT WEBSITE PROMOTING THIRD PARTY LIVE CONCERTS AND SHOWS; VIRAL MARKETING SERVICES FOR PERFORMING ARTISTS; DISTRIBUTORSHIPS IN THE FIELD OF PRERECORDED MUSIC AND ASSOCIATED SUPPORT SERVICES, NAMELY, MERCHANDISING, AND DISTRIBUTION OF PRINTED AND E-COMMERCE PROMOTIONAL MATERIALS (U.S. CLS. 100, 101 AND 102).

FIRST USE 3-13-2010; IN COMMERCE 3-13-2010.

**CLASS 35—(Continued).**

3,941,062. ROXANNE EMMERICH, EDEN PRAIRIE, MN. SN 77-369,895. PUB. 5-27-2008, FILED 1-11-2008.

# BankShop

THE MARK CONSISTS OF STANDARD CHARACTERS WITHOUT CLAIM TO ANY PARTICULAR FONT, STYLE, SIZE, OR COLOR.

FOR MYSTERY SHOPPING AND SERVICE PERFORMANCE PROGRAMS INTENDED TO EVALUATE CUSTOMER SERVICE AND QUALITY CONTROL FOR BANKS AND FINANCIAL SERVICE ORGANIZATIONS; COLLECTION AND REPORTING OF PERFORMANCE SURVEY DATA FOR BANKS AND FINANCIAL SERVICE ORGANIZATIONS (U.S. CLS. 100, 101 AND 102).

FIRST USE 4-6-2007; IN COMMERCE 4-6-2007.

3,941,068. YUNG SHIN PHARM. IND. CO., LTD., TACHIA TAICHUNG, TAIWAN. SN 77-395,509. PUB. 12-9-2008, FILED 2-13-2008.



THE ENGLISH TRANSLATION OF THE WORDING "YUNG SHIN" IS "TRUST FOREVER".

FOR RETAIL DEPARTMENT STORES; RETAIL CONVENIENCE STORES; MAIL ORDER SERVICES FEATURING HEALTHCARE SUPPLEMENTS, NUTRITIONAL SUPPLEMENTS, DIETARY SUPPLEMENTS, VITAMIN SUPPLEMENTS; COMPUTERIZED ON-LINE ORDERING SERVICES IN THE FIELD OF HEALTHCARE SUPPLEMENTS, NUTRITIONAL SUPPLEMENTS, DIETARY SUPPLEMENTS, VITAMIN SUPPLEMENTS; RETAIL PHARMACY SERVICES; RETAIL STORE SERVICES FEATURING CHEMICAL PRODUCTS; RETAIL STORE SERVICES FEATURING COSMETIC PRODUCTS; RETAIL STORE SERVICES FEATURING FOOD AND BEVERAGES (U.S. CLS. 100, 101 AND 102).

FIRST USE 1-1-2010; IN COMMERCE 9-1-2010.

3,941,077. RITA RESTAURANT CORP., MADISON, GA. SN 77-433,205. PUB. 12-15-2009, FILED 3-27-2008.

## RITA RESTAURANT CORP.

THE MARK CONSISTS OF STANDARD CHARACTERS WITHOUT CLAIM TO ANY PARTICULAR FONT, STYLE, SIZE, OR COLOR.

**CLASS 35—(Continued).**

NO CLAIM IS MADE TO THE EXCLUSIVE RIGHT TO USE "RESTAURANT CORP.", APART FROM THE MARK AS SHOWN.

FOR RESTAURANT MANAGEMENT SERVICES IN THE NATURE OF PROVIDING BUSINESS ADVICE AND SUPPORT SERVICES TO FRANCHISEES AND PROSPECTIVE FRANCHISEES, EXCLUDING FRANCHISEES AND PROSPECTIVE FRANCHISEES PRIMARILY OFFERING ICE CREAM, ITALIAN ICE, FROZEN CUSTARDS, SMOOTHIES, AND OTHER FROZEN CONFECTIONS (U.S. CLS. 100, 101 AND 102).

FIRST USE 7-8-2008; IN COMMERCE 7-8-2008.

3,941,097. THE RIGHT CARD LLC, IRVINE, CA. SN 77-503,490. PUB. 6-9-2009, FILED S.R. 6-19-2008; AM. P.R. 3-18-2009.

# Flexity

THE MARK CONSISTS OF STANDARD CHARACTERS WITHOUT CLAIM TO ANY PARTICULAR FONT, STYLE, SIZE, OR COLOR.

FOR PROMOTING THE CREDIT CARD SERVICES OF OTHERS BY REVIEWING OFFERS OF INCENTIVES AVAILABLE FROM CREDIT CARD COMPANIES (U.S. CLS. 100, 101 AND 102).

FIRST USE 10-1-2010; IN COMMERCE 10-1-2010.

3,941,115. AMERICAN EXPRESS MARKETING & DEVELOPMENT CORP., NEW YORK, NY. SN 77-539,665. PUB. 4-14-2009, FILED 8-5-2008.

## AX GREEN TRAVEL SOLUTIONS

THE MARK CONSISTS OF STANDARD CHARACTERS WITHOUT CLAIM TO ANY PARTICULAR FONT, STYLE, SIZE, OR COLOR.

NO CLAIM IS MADE TO THE EXCLUSIVE RIGHT TO USE "GREEN TRAVEL SOLUTIONS", APART FROM THE MARK AS SHOWN.

FOR PROVIDING BUSINESS AND COMMERCIAL INFORMATION IN THE FIELD OF BUSINESS TRAVEL MANAGEMENT AND THE BUSINESS TRAVEL INDUSTRY; BUSINESS CONSULTING AND INFORMATION SERVICES, NAMELY, BUSINESS CONSULTING SERVICES TO DESIGN AND IMPLEMENT A STRATEGY AND TRAVEL POLICIES AIMED AT MANAGING THE ENVIRONMENTAL IMPACT OF BUSINESS TRAVEL (U.S. CLS. 100, 101 AND 102).

FIRST USE 7-31-2008; IN COMMERCE 7-31-2008.

**CLASS 35—(Continued).**

3,941,133. CALLCENTRIC WHOLESALE, INC., FORMERLY ACCATEL, INC., NEW YORK, NY. SN 77-568,287. PUB. 9-8-2009, FILED 9-11-2008.

# ACCATEL

THE MARK CONSISTS OF STANDARD CHARACTERS WITHOUT CLAIM TO ANY PARTICULAR FONT, STYLE, SIZE, OR COLOR.

FOR WHOLESALE AND RETAIL STORE SERVICES FEATURING TELECOMMUNICATIONS SERVICE PLANS AND TELECOMMUNICATIONS SERVICE ACTIVATION (U.S. CLS. 100, 101 AND 102).

FIRST USE 1-15-2002; IN COMMERCE 10-22-2002.

---

3,941,155. CANDID CAREER, LLC, BETHESDA, MD. SN 77-603,906. PUB. 3-24-2009, FILED 10-30-2008.



THE MARK CONSISTS OF THE TERM "CANDIDCAREER", FOLLOWED BY A DOT AND THE TOP-LEVEL DOMAIN "COM", UNDERNEATH TWO HANDS WITH THE THUMBS EXTENDED HORIZONTALLY AND TOUCHING AND THE INDEX FINGERS EXTENDED VERTICALLY, DEPICTING AN ABSTRACT FRAME.

FOR PROVIDING CAREER INFORMATION (U.S. CLS. 100, 101 AND 102).

FIRST USE 11-26-2009; IN COMMERCE 11-26-2009.

---

3,941,158. FREEDOM GROUP, INC., RENO, NV. SN 77-607,357. PUB. 10-27-2009, FILED 11-4-2008.

# CARBSTAR

THE MARK CONSISTS OF STANDARD CHARACTERS WITHOUT CLAIM TO ANY PARTICULAR FONT, STYLE, SIZE, OR COLOR.

FOR BUSINESS CONSULTATION SERVICES TO ASSIST BUSINESSES WITH LOW CARBON FUEL STANDARDS REGULATION COMPLIANCE (U.S. CLS. 100, 101 AND 102).

FIRST USE 1-17-2011; IN COMMERCE 1-17-2011.

**CLASS 35—(Continued).**

3,941,174. BULLET LINE, LLC, MIAMI, FL. SN 77-632,235. PUB. 7-7-2009, FILED 12-12-2008.



THE MARK CONSISTS OF A GLOBE WITH TWO FOOT PRINTS ON EACH SIDE OF SOUTH AMERICA AND THE WORDS "EARTH PRINT" IN STYLIZED LETTERING BELOW.

FOR WHOLESALE STORE SERVICES FEATURING THE PREPARATION OF CUSTOM ADVERTISEMENTS AND CUSTOM PROMOTIONAL PRODUCTS FOR OTHERS (U.S. CLS. 100, 101 AND 102).

FIRST USE 9-0-2008; IN COMMERCE 9-0-2008.

---

3,941,183. HEALTH CARE ACCESS NOW, CINCINNATI, OH. SN 77-635,680. PUB. 5-26-2009, FILED 12-18-2008.

## Health Care Access Now

THE MARK CONSISTS OF STANDARD CHARACTERS WITHOUT CLAIM TO ANY PARTICULAR FONT, STYLE, SIZE, OR COLOR.

NO CLAIM IS MADE TO THE EXCLUSIVE RIGHT TO USE "HEALTH CARE ACCESS", APART FROM THE MARK AS SHOWN.

FOR BUSINESS CONSULTING, MANAGEMENT AND OPERATIONS ASSISTANCE IN THE HEALTH CARE FIELD, SPECIFICALLY FOR HEALTH AND SOCIAL SERVICE ORGANIZATIONS THAT PROVIDE PRIMARY CARE, SOCIAL SERVICES AND BEHAVIORAL HEALTH CARE FOR UNINSURED AND LOW-INCOME INDIVIDUALS (U.S. CLS. 100, 101 AND 102).

FIRST USE 10-31-2010; IN COMMERCE 10-31-2010.

**CLASS 35—(Continued).**

3,941,193. THE ORGANIC MATTRESS STORE, INC., HELPERTOWN, PA. SN 77-647,416. PUB. 6-1-2010, FILED 1-12-2009.

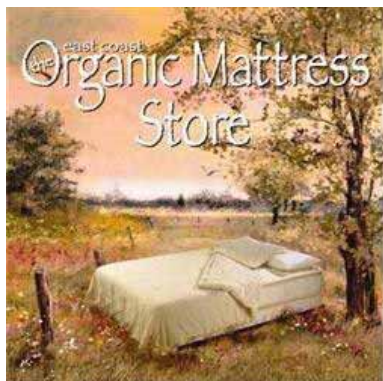

NO CLAIM IS MADE TO THE EXCLUSIVE RIGHT TO USE "EAST COAST ORGANIC MATTRESS STORE", APART FROM THE MARK AS SHOWN.

THE COLOR(S) WHITE, BLACK, BROWN, EGGSHELL, GREEN, PINK, BLUE, YELLOW IS/ARE CLAIMED AS A FEATURE OF THE MARK.

THE MARK CONSISTS OF THE WORDS "EAST COAST" WHICH APPEAR IN SMALLER LETTERS ABOVE THE WORDS "ORGANIC MATTRESS STORE" WITH THE WORD "THE" APPEARING INSIDE OF THE "O" OF "ORGANIC". ALL OF THE WORDS IN THE MARK APPEAR IN WHITE LETTERING WITH BLACK SHADOWING. THE BACKGROUND CONSISTS OF A MULTICOLORED FLOWERY MEADOW WITH BROWN FENCE POSTS AND A BED WITH AN EGGSHELL COLORED BLANKET AND PILLOWS. ABOVE THE BED AND IN THE BACKGROUND APPEAR TREES WITH GREEN LEAVES. THE SKY APPEARS IN A MIX OF PINK, BLUE, YELLOW AND WHITE.

FOR WHOLESALE AND RETAIL STORE SERVICES, ON-LINE RETAIL STORE SERVICES, AND MAIL ORDER CATALOG SERVICES FEATURING SLEEP RELATED PRODUCTS AND ACCESSORIES, NAMELY, ORGANIC MATTRESSES, ORGANIC MATTRESS FOUNDATIONS, BED FRAMES, BEDROOM FURNITURE AND ORGANIC BED LINENS (U.S. CLS. 100, 101 AND 102).

FIRST USE 1-15-2009; IN COMMERCE 1-15-2009.

3,941,203. ALLING, JOHN PAUL, FOLSOM, CA. SN 77-653,709. PUB. 6-15-2010, FILED 1-21-2009.



OWNER OF U.S. REG. NO. 3,527,281.

THE COLOR(S) GREEN, BLACK AND WHITE IS/ARE CLAIMED AS A FEATURE OF THE MARK.

THE MARK CONSISTS OF AN IMAGE OF A WINDING BLACK ROAD WITH A WHITE HASH MARK. THE ROAD HAS GREEN GRASS ON BOTH SIDES. THE WORDS "SENSIBLE DRIVER" APPEAR IN GREEN TO THE RIGHT OF THE IMAGE.

FOR ADVERTISING, MARKETING AND PROMOTIONAL SERVICES FOR AUTOMOTIVE DEALERSHIPS AND AUTOMOTIVE REPAIR BUSINESSES (U.S. CLS. 100, 101 AND 102).

FIRST USE 9-22-2009; IN COMMERCE 9-22-2009.

**CLASS 35—(Continued).**

3,941,212. ACCESS COMMUNITY HEALTH NETWORK, CHICAGO, IL. SN 77-661,484. PUB. 6-22-2010, FILED 2-2-2009.

**EXAMÍNATE COMADRE**

THE MARK CONSISTS OF STANDARD CHARACTERS WITHOUT CLAIM TO ANY PARTICULAR FONT, STYLE, SIZE, OR COLOR.

THE ENGLISH TRANSLATION OF "EXAMÍNATE COMADRE" IN THE MARK IS "GET EXAMINED, WOMAN FRIEND".

FOR CONDUCTING EVENTS FOR PROMOTING BREAST CANCER AWARENESS AND SCREENINGS, AND FOR PUBLICIZING DIAGNOSTIC AND TREATMENT OPPORTUNITIES FOR WHICH WOMEN MAY BE ELIGIBLE (U.S. CLS. 100, 101 AND 102).

FIRST USE 2-19-2010; IN COMMERCE 2-19-2010.

3,941,221. COPART, INC., FAIRFIELD, CA. SN 77-667,618. PUB. 1-12-2010, FILED 2-10-2009.

**COPART**

THE MARK CONSISTS OF STANDARD CHARACTERS WITHOUT CLAIM TO ANY PARTICULAR FONT, STYLE, SIZE, OR COLOR.

OWNER OF U.S. REG. NO. 2,802,136.

FOR ARRANGING AND CONDUCTING AUCTIONS IN THE FIELD OF MOTOR VEHICLES, TRAILERS, INDUSTRIAL EQUIPMENT AND HOUSEHOLD FURNISHINGS AND FIXTURES; ONLINE AUCTION SERVICES; PROMOTING THE SALE OF GOODS OF OTHERS VIA A GLOBAL COMPUTER NETWORK; REMARKETING SERVICES, NAMELY, ASSISTING IN THE MARKETING AND SALE OF GOODS OF OTHERS; ON-LINE TRADING SERVICES IN WHICH APPLICANT POSTS GOODS TO BE AUCTIONED AND BIDDING IS DONE VIA THE INTERNET; ADMINISTRATION OF THE SALES TRANSACTIONS OF THE GOODS OF OTHERS; ARRANGING FOR THE TRANSPORT AND TOWING OF VEHICLES AND INDUSTRIAL EQUIPMENT FOR OTHERS; CONSULTING SERVICES IN THE MARKETING AND SALE OF GOODS OF OTHERS; RETAIL AND WHOLESALE STORE SERVICES FEATURING MOTOR VEHICLES AND INDUSTRIAL EQUIPMENT (U.S. CLS. 100, 101 AND 102).

FIRST USE 0-0-1982; IN COMMERCE 0-0-1982.



**CLASS 35—(Continued).**

3,941,239. BP MEDIA CONCEPTS, LLC, WOODBRIDGE, CT. SN 77-690,311. PUB. 9-22-2009, FILED 3-13-2009.

**GraysAnatomyJobs**

THE MARK CONSISTS OF STANDARD CHARACTERS WITHOUT CLAIM TO ANY PARTICULAR FONT, STYLE, SIZE, OR COLOR.

FOR EMPLOYMENT HIRING, RECRUITING, PLACEMENT, AND STAFFING SERVICES FOR HOSPITAL AND HEALTHCARE PROFESSIONALS (U.S. CLS. 100, 101 AND 102).

FIRST USE 3-13-2009; IN COMMERCE 3-13-2009.

---

3,941,244. LORI L. SILVERMAN, MESA, AZ. AND KAREN DIETZ, SAN DIEGO, AZ. SN 77-696,929. PUB. 11-10-2009, FILED 3-23-2009.

**WAKE UP YOUR COMPANY**

THE MARK CONSISTS OF STANDARD CHARACTERS WITHOUT CLAIM TO ANY PARTICULAR FONT, STYLE, SIZE, OR COLOR.

FOR BUSINESS CONSULTATION SERVICES, NAMELY, AIDING BUSINESS ORGANIZATIONS IN ACHIEVING AND MAINTAINING A COMPETITIVE ADVANTAGE THROUGH INSPIRATIONAL WORK-PLACE STORIES AND INFORMATION (U.S. CLS. 100, 101 AND 102).

FIRST USE 3-11-2009; IN COMMERCE 1-28-2011.

---

3,941,258. ARETI II LIMITED, JACKSONVILLE, FL. SN 77-721,178. PUB. 3-9-2010, FILED 4-23-2009.

**ARETI YACHT MANAGEMENT LTD.**

THE MARK CONSISTS OF STANDARD CHARACTERS WITHOUT CLAIM TO ANY PARTICULAR FONT, STYLE, SIZE, OR COLOR.

NO CLAIM IS MADE TO THE EXCLUSIVE RIGHT TO USE "YACHT MANAGEMENT LTD.," APART FROM THE MARK AS SHOWN.

THE WORDING "ARETI" HAS NO MEANING IN A FOREIGN LANGUAGE.

FOR BUSINESS MANAGEMENT OF YACHTS FOR YACHT OWNERS (U.S. CLS. 100, 101 AND 102).

FIRST USE 1-19-2009; IN COMMERCE 1-19-2009.

**CLASS 35—(Continued).**

3,941,262. THE HEART EXCHANGE, LLC, BRIARCLIFF MANOR, NY. SN 77-723,051. PUB. 7-13-2010, FILED 4-27-2009.

**Price Anything**

THE MARK CONSISTS OF STANDARD CHARACTERS WITHOUT CLAIM TO ANY PARTICULAR FONT, STYLE, SIZE, OR COLOR.

NO CLAIM IS MADE TO THE EXCLUSIVE RIGHT TO USE "PRICE", APART FROM THE MARK AS SHOWN.

FOR ADVERTISING AGENCIES; ADVERTISING AGENCIES PROVIDING THE STRATEGY, DESIGN AND EXECUTION OF PROGRAMS TO PROMOTE BUSINESSES IN THE FOOD AND FOOD SERVICE INDUSTRIES; ADVERTISING AGENCIES, NAMELY, PROMOTING THE GOODS AND SERVICES OF OTHERS; ADVERTISING AGENCIES, NAMELY, PROMOTING THE SERVICES OF CORPORATE, SMALL, AND NON PROFIT BUSINESSES THROUGH THE DISTRIBUTION OF PRINTED AND AUDIO PROMOTIONAL MATERIALS AND BY RENDERING SALES PROMOTION ADVICE; ADVERTISING AGENCY SPECIALIZING IN THE DESIGN AND EXECUTION OF WORD OF MOUTH, VIRAL, BUZZ AND EXPERIENTIAL MARKETING PROGRAMS; ADVERTISING AND ADVERTISEMENT SERVICES; ADVERTISING AND BUSINESS ADVICE RELATING TO TELEMATICS' SERVICES; ADVERTISING AND BUSINESS MANAGEMENT CONSULTANCY; ADVERTISING AND BUSINESS SERVICES, NAMELY, SECURING AIRTIME ON ALL FORMS OF MEDIA COMMUNICATIONS STATIONS, SYSTEMS, NETWORKS, AND SERVICES FOR THE PURPOSE OF PROMOTING THE GOODS AND SERVICES OF OTHERS; ADVERTISING AND COMMERCIAL INFORMATION SERVICES, VIA THE INTERNET; ADVERTISING AND DIRECTORY SERVICES, NAMELY, PROMOTING THE SERVICES OF OTHERS BY PROVIDING A WEB PAGE FEATURING LINKS TO THE WEBSITES OF OTHERS; ADVERTISING AND MARKETING; ADVERTISING AND MARKETING SERVICES, NAMELY, PROMOTING THE GOODS AND SERVICES OF OTHERS; ADVERTISING AND PROMOTION SERVICES AND RELATED CONSULTING; ADVERTISING AND PROMOTIONAL SERVICES; ADVERTISING AND PUBLICITY SERVICES; ADVERTISING AND PUBLICITY SERVICES, NAMELY, PROMOTING THE GOODS, SERVICES, BRAND IDENTITY AND COMMERCIAL INFORMATION AND NEWS OF THIRD PARTIES THROUGH PRINT, AUDIO, VIDEO, DIGITAL AND ON-LINE MEDIUM; ADVERTISING BUSINESS ESPECIALLY IN THE FIELD OF TELEMATIC AND TELEPHONE NETWORKS; ADVERTISING BY TRANSMISSION OF ON-LINE PUBLICITY FOR THIRD PARTIES THROUGH ELECTRONIC COMMUNICATIONS NETWORKS; ADVERTISING CONSULTATION; ADVERTISING FLYER DISTRIBUTION; ADVERTISING PARTICULARLY SERVICES FOR THE PROMOTION OF GOODS; ADVERTISING RELATING TO PHARMACEUTICAL PRODUCTS AND IN-VIVO IMAGING PRODUCTS; ADVERTISING SERVICES; ADVERTISING SERVICES FOR PROMOTING THE BROKERAGE OF STOCKS AND OTHER SECURITIES; ADVERTISING SERVICES OF A RADIO AND TELEVISION ADVERTISING AGENCY; ADVERTISING SERVICES RELATING TO SANDWICHES; ADVERTISING SERVICES, FOR THIRD PARTIES, IN CONNECTION WITH THE COMMERCIALIZATION AND SALE OF PERFUMERY AND COSMETIC ARTICLES, PRODUCTS FOR HOUSEHOLD PURPOSES, OPTICAL PRODUCTS, CLOCKS AND TIMEPIECES, JEWELLERY, FURNISHING ARTICLES; ADVERTISING SERVICES, NAMELY, COST-PER-ACTION ON-LINE ADVERTISING; ADVERTISING SERVICES, NAMELY, CREATING CORPORATE AND BRAND IDENTITY FOR OTHERS; ADVERTISING SERVICES, NAMELY, CREATING CORPORATE LOGOS FOR OTHERS; ADVERTISING SERVICES, NAMELY, PRO-

**CLASS 35—(Continued).**

DUCTION OF SPECIAL EFFECTS INCLUDING MODEL-MAKING SERVICES, COMPUTER-GENERATED IMAGERY AND COMPUTER-GENERATED GRAPHICS FOR THE PRODUCTION OF COMMERCIALS; ADVERTISING SERVICES, NAMELY, PROMOTING AND MARKETING THE GOODS AND SERVICES OF OTHERS IN THE FIELD OF UPSCALE CHOICES SUCH AS CULTURAL EVENTS, RESTAURANTS, SHOPPING, AND TRAVEL VIA PRINT AND ELECTRONIC MEDIA; ADVERTISING SERVICES, NAMELY, PROMOTING AND MARKETING THE GOODS AND SERVICES OF OTHERS THROUGH ALL PUBLIC COMMUNICATION MEANS; ADVERTISING SERVICES, NAMELY, PROMOTING CAR DEALERSHIPS OF OTHERS; ADVERTISING SERVICES, NAMELY, PROMOTING PROPERTIES FOR SALE BY OWNER VIA THE INTERNET; ADVERTISING SERVICES, NAMELY, PROMOTING THE BOOKS OF OTHERS IN THE FIELD OF LAW BY MEANS OF NEWS AND REVIEWS REGARDING SAME; ADVERTISING SERVICES, NAMELY, PROMOTING THE FOOD AND WINE OF OTHERS; ADVERTISING SERVICES, NAMELY, PROMOTING THE GIFT CARDS OF OTHERS; ADVERTISING SERVICES, NAMELY, PROMOTING THE SANDWICHES OF OTHERS; ADVERTISING SERVICES, NAMELY, PROVIDING A WEBSITE FOR THE PROMOTION OF THE BOOKS OF OTHERS IN THE FIELD OF LAW, INCLUDING NEWS AND REVIEWS REGARDING SAME; ADVERTISING SERVICES, NAMELY, PROVIDING ADVERTISING SPACE IN A PERIODICAL; ADVERTISING SERVICES, NAMELY, PROVIDING INFORMATION AS TO THE AVAILABILITY OF ADVERTISING SPACE FOR RENT OR PURCHASE; ADVERTISING SERVICES, PUBLIC RELATIONS AND MARKETING SERVICES, NAMELY, PROMOTING AND MARKETING THE GOODS AND SERVICES OF OTHERS THROUGH ALL PUBLIC COMMUNICATION MEANS; ADVERTISING TEXT PUBLICATION SERVICES; ADVERTISING THROUGH ALL PUBLIC COMMUNICATION MEANS; ADVERTISING VIA ELECTRONIC MEDIA AND SPECIFICALLY THE INTERNET; ADVERTISING, INCLUDING PROMOTION OF PRODUCTS AND SERVICES OF THIRD PARTIES THROUGH SPONSORING ARRANGEMENTS AND LICENSE AGREEMENTS RELATING TO INTERNATIONAL SPORTS' EVENTS; ADVERTISING, INCLUDING PROMOTION RELATING TO THE SALE OF ARTICLES AND SERVICES FOR THIRD PARTIES BY THE TRANSMISSION OF ADVERTISING MATERIAL AND THE DISSEMINATION OF ADVERTISING MESSAGES ON COMPUTER NETWORKS; ADVERTISING, MARKETING AND PROMOTING THE GOODS AND SERVICES OF OTHERS USING KIOSKS; ADVERTISING, MARKETING AND PROMOTION SERVICES; ADVERTISING, MARKETING AND PROMOTIONAL SERVICES FOR AUTOMOTIVE DEALERSHIPS; ADVERTISING, MARKETING AND PROMOTIONAL SERVICES FOR LIGHT AND HEAVY EQUIPMENT DEALERSHIPS; ADVERTISING, MARKETING AND PROMOTIONAL SERVICES FOR THE DONATION OF HUMAN BLOOD THAT EXACTLY MATCHES THE BLOOD TYPE OF INDIVIDUALS NEEDING TRANSFUSIONS; ADVERTISING, MARKETING AND PROMOTIONAL SERVICES RELATED TO ALL INDUSTRIES FOR THE PURPOSE OF FACILITATING NETWORKING AND SOCIALIZING OPPORTUNITIES FOR BUSINESS PURPOSES; ADVERTISING, PROMOTION AND MARKETING SERVICES IN THE NATURE OF E-MAIL BLAST CAMPAIGNS FOR OTHERS; AGENCIES FOR ADVERTISING TIME AND SPACE; ARRANGING AND CONDUCTING OF FAIRS AND EXHIBITIONS FOR BUSINESS AND ADVERTISING PURPOSES; BUSINESS MANAGEMENT AND CONSULTING SERVICES FOR THE HEALTH CARE INDUSTRY, NAMELY, CUSTOMER SERVICE, ACCOUNTING SERVICES, AND WEB-BASED ADVERTISING AND MARKETING SERVICES; CINEMA ADVERTISING; COMPILATION OF ADVERTISEMENTS FOR USE AS WEB PAGES ON THE INTERNET; CONSUMER LOYALTY SERVICES FOR COMMERCIAL, PROMOTIONAL, AND/OR ADVERTISING PURPOSES, NAMELY, ADMINISTRATION OF FREQUENT FLYER PROGRAM THAT ALLOWS MEMBERS TO REDEEM MILES FOR POINTS OR AWARDS OFFERED BY OTHER LOYALTY PROGRAMS; COOPERATIVE ADVERTISING AND MARKETING; COOPERATIVE ADVERTISING AND MARKETING SERVICES BY WAY OF SOLICITATION, CUSTOMER SERVICE AND PROVIDING MARKETING INFORMATION VIA WEB SITES

**CLASS 35—(Continued).**

ON A GLOBAL COMPUTER NETWORK; CREATING AND UPDATING ADVERTISING MATERIAL; CREATION OF MARKETING TOOLS DESIGNED TO INCREASE A CLIENT COMPANY'S KNOWLEDGE OF CUSTOMER NEEDS, AND ITS COMPETITORS' PRODUCTS AND SERVICES, PRICING, ADVERTISING STRATEGY AND SALES STRATEGY; CUSTOMER LOYALTY SERVICES AND CUSTOMER CLUB SERVICES, FOR COMMERCIAL, PROMOTIONAL AND/OR ADVERTISING PURPOSES; DESIGN OF ADVERTISING FLYERS FOR OTHERS; DESIGN OF ADVERTISING MATERIALS FOR OTHERS; DESIGN OF INTERNET ADVERTISING; DEVELOPMENT, OPERATION AND ADMINISTRATION OF DIGITAL SIGNAGE SYSTEMS AND DIGITAL ADVERTISING SYSTEMS FOR OTHERS, NAMELY, PROVIDING ADVERTISING SPACE BY ELECTRONIC MEANS AND GLOBAL COMPUTER INFORMATION NETWORKS; DIRECT MAIL ADVERTISING; DIRECT MARKETING ADVERTISING FOR OTHERS; DISPLAYING ADVERTISEMENTS FOR OTHERS; DISSEMINATION OF ADVERTISEMENTS; DISSEMINATION OF ADVERTISEMENTS AND OF ADVERTISING MATERIAL; DISSEMINATION OF ADVERTISING FOR OTHERS VIA AN ON-LINE COMMUNICATIONS NETWORK ON THE INTERNET; DISSEMINATION OF ADVERTISING FOR OTHERS VIA THE INTERNET; DISSEMINATION OF ADVERTISING MATERIAL; DISSEMINATION OF ADVERTISING MATTER; DISSEMINATION OF ADVERTISING, SCHEDULING AND MANAGING OF TRAINING COURSES AND PROGRAMS FOR OTHERS VIA A GLOBAL COMPUTER NETWORK; DISTRIBUTION AND DISSEMINATION OF ADVERTISING MATERIALS; DISTRIBUTION OF ADVERTISEMENTS AND COMMERCIAL ANNOUNCEMENTS; DISTRIBUTION OF ADVERTISING MAIL AND OF ADVERTISING SUPPLEMENTS ATTACHED TO REGULAR EDITIONS; DISTRIBUTION OF PRODUCTS FOR ADVERTISING PURPOSES; ELECTRONIC BILLBOARD ADVERTISING; ELECTRONIC COMMERCE SERVICES, NAMELY, PROVIDING INFORMATION ABOUT PRODUCTS VIA TELECOMMUNICATION NETWORKS FOR ADVERTISING AND SALES PURPOSES; ENTERTAINMENT MARKETING SERVICES, NAMELY, MARKETING, PROMOTION AND ADVERTISING FOR INDEPENDENT RECORDING ARTISTS; INTERNET ADVERTISING SERVICES; ISSUING AND UPDATING OF ADVERTISING TEXTS; LAYOUT SERVICES FOR ADVERTISING PURPOSES; MARKETING AND ADVERTISING SERVICES FOR AUTOMOBILE DEALERSHIPS; MARKETING, ADVERTISING AND PROMOTING THE GOODS AND SERVICES OF OTHERS IN THE FIELD OF TRAVEL AND TOURISM, NAMELY, PROVIDING INFORMATION VIA MAIL AND ELECTRONIC MAIL; MARKETING, ADVERTISING, AND PROMOTING THE RETAIL GOODS AND SERVICES OF OTHERS TO WIRELESS ELECTRONIC DEVICES; MARKETING, PROMOTIONAL AND ADVERTISING SERVICES PROVIDED BY MOBILE TELEPHONE CONNECTIONS; MEDIA BUYING ADVICE, NAMELY, ADVISING THE CLIENT HOW MUCH MEDIA TIME, AND AT WHAT TIMES THE CLIENT SHOULD BE PURCHASING ADVERTISING; MEDIA PLANNING, NAMELY, ADVISING THE CLIENT ON THE CORRECT TIMES AND STATIONS TO ADVERTISE BASED ON MEDIA ANALYSIS OF THE MARKET FOR THAT MEDIA; MEDIA PRODUCTION LOCATION SCOUTING SERVICES FOR ADVERTISING PURPOSES; MEDIATION OF ADVERTISING; MODELING FOR ADVERTISING OR SALES PROMOTION; MODELING SERVICES FOR ADVERTISING OR SALES PROMOTION; MUSIC SELECTION SERVICES FOR USE IN ADVERTISING; ON-LINE ADVERTISING AND MARKETING SERVICES; ON-LINE ADVERTISING ON COMPUTER COMMUNICATION NETWORKS; ORGANIZATION AND HOLDING OF FAIRS FOR COMMERCIAL OR ADVERTISING PURPOSES; ORGANIZING EXHIBITIONS FOR COMMERCIAL OR ADVERTISING PURPOSES; ORGANIZATION OF EVENTS, EXHIBITIONS, FAIRS AND SHOWS FOR COMMERCIAL, PROMOTIONAL AND ADVERTISING PURPOSES; ORGANIZING BUSINESS EXPOSITIONS FOR MARKETING ADVERTISING SPACE; ORGANIZING EXHIBITIONS FOR COMMERCIAL OR ADVERTISING PURPOSES; ORGANIZING EXHIBITIONS FOR MARKETING ADVERTISING; OUT-OF-HOME ADVERTISING SERVICES, NAMELY, RENTAL OF ADVERTISING SPACE, AND PREPARING AND PLACING ADVERTISEMENTS FOR OTHERS; PAY PER CLICK

**CLASS 35—(Continued).**

(PPC) ADVERTISING MANAGEMENT SERVICES; PLACING ADVERTISEMENTS FOR OTHERS; PLANNING AND CONDUCTING OF TRADE FAIRS, EXHIBITIONS AND PRESENTATIONS FOR ECONOMIC OR ADVERTISING PURPOSES; PREPARATION AND REALIZATION OF MEDIA AND ADVERTISING PLANS AND CONCEPTS; PREPARATION OF CUSTOM ADVERTISEMENTS FOR OTHERS; PREPARATION OF CUSTOM OR NON-CUSTOM ADVERTISING FOR BUSINESSES FOR DISSEMINATION VIA THE WEB, CD OR DVD FOR OPTIONAL UPLOAD OR DOWNLOAD TO A COMPUTER; PREPARING ADVERTISEMENTS FOR OTHERS; PREPARING AND PLACING ADVERTISEMENTS FOR OTHERS; PREPARING AND PLACING OF ADVERTISEMENTS; PREPARING AND PLACING OUTDOOR ADVERTISEMENTS FOR OTHERS; PREPARING AUDIOVISUAL DISPLAYS IN THE FIELD OF MARKETING ADVERTISING TO BUSINESS; PREPARING AUDIOVISUAL PRESENTATIONS FOR USE IN ADVERTISING; PREPARING SPEECHES AND ORAL PRESENTATIONS FOR OTHERS FOR USE IN ADVERTISING; PROCESSING TELEPHONE INQUIRIES REGARDING ADVERTISED GOODS AND SERVICES; PRODUCTION OF ADVERTISING MATTER AND COMMERCIALS; PRODUCTION OF FILM AND TELEVISION ADVERTISING; PROMOTING THE GOODS AND SERVICES OF OTHERS BY DISTRIBUTING ADVERTISING MATERIALS THROUGH A VARIETY OF METHODS; PROMOTING THE GOODS AND SERVICES OF OTHERS BY PREPARING AND PLACING ADVERTISEMENTS IN AN ELECTRONIC MAGAZINE ACCESSED THROUGH A GLOBAL COMPUTER NETWORK; PROMOTING, ADVERTISING AND MARKETING OF THE ON-LINE WEB SITES OF OTHERS; PROMOTION, ADVERTISING AND MARKETING OF ON-LINE WEBSITES; PROMOTIONAL SERVICES, NAMELY, DISTRIBUTION OF ADVERTISING FLYERS, COUPONS, CATALOGS AND PROMOTIONAL ITEMS OF OTHERS; PROVIDING A SEARCHABLE ONLINE ADVERTISING GUIDE FEATURING THE GOODS AND SERVICES OF OTHER ONLINE VENDORS ON THE INTERNET; PROVIDING A WEB SITE AT WHICH FITNESS PROFESSIONALS AND FACILITIES CAN POST PROMOTIONAL PROFILES AND RESPOND TO ADVERTISEMENTS FOR THEIR SERVICES; PROVIDING A WEB SITE THAT ENABLES USERS TO POST ITEMS FOR SALE THROUGH ON-LINE CLASSIFIED ADVERTISEMENTS; PROVIDING A WEB SITE WHICH FEATURES ADVERTISEMENTS FOR THE GOODS AND SERVICES OF OTHERS ON A GLOBAL COMPUTER NETWORK; PROVIDING ADVERTISING SERVICES; PROVIDING ADVERTISING SERVICES USING 3D AND ANIMATION DESIGNS; PROVIDING ADVERTISING SPACE IN PERIODICALS, NEWSPAPERS AND MAGAZINES; PROVIDING ADVERTISING, MARKETING AND PROMOTIONAL SERVICES FOR THE PHARMACEUTICAL AND MEDICAL INDUSTRY; PROVIDING ADVERTISING, MARKETING AND PROMOTIONAL SERVICES FOR THE PHARMACEUTICAL AND MEDICAL PRODUCTS OF OTHERS; PROVIDING ADVERTISING, MARKETING AND PROMOTIONAL SERVICES, NAMELY, DEVELOPMENT OF ADVERTISING CAMPAIGNS FOR BUSINESSES; PROVIDING AN INTERNET WEB SITE FOR CLASSIFIED ADVERTISING TO BUY AND SELL UKRAINIAN RELATED WARES, ART, ANTIQUES, BOOKS, EMBROIDERY, COSTUMES, COLLECTIBLES, INSTRUMENTS, MEMORABILIA AND OTHER ONE-OF-A-KIND ITEMS; PROVIDING AN INTERNET WEB SITE TO ADVERTISE SERVICES OF INTEREST TO THE UKRAINIAN COMMUNITY IN THE UNITED STATES OF AMERICA AND CANADA AND TO ADVERTISE SERVICES PROVIDED BY INDIVIDUALS OF UKRAINIAN ORIGIN; PROVIDING AND RENTAL OF ADVERTISING SPACE ON THE INTERNET; PROVIDING SPACE AT A WEB SITE FOR THE ADVERTISEMENT OF THE GOODS AND SERVICES OF OTHERS; PROVIDING TELEVISION ADVERTISING FOR OTHERS; PROVISION OF ADVERTISING SPACE BY ELECTRONIC MEANS AND GLOBAL INFORMATION NETWORKS; PROVISION OF SPACE ON WEBSITES FOR ADVERTISING GOODS AND SERVICES; PUBLIC RELATIONS, ADVERTISING AND MARKETING SERVICES FOR THE TOURISM AND CONVENTION INDUSTRY, NAMELY, ORGANIZING AND HOSTING SITE INSPECTIONS AND FAMILIARIZATION TOURS FOR WHOLESALERS, TOUR OPERATORS, TRAVEL AGENTS, MEETING AND INCENTIVE TRAVEL PLANNERS AND TRAVEL MEDIA; PUBLISH-

**CLASS 35—(Continued).**

ING OF ADVERTISING TEXTS; REAL ESTATE ADVERTISING SERVICES; RECRUITMENT ADVERTISEMENT SERVICES, NAMELY, POSTING OF CLINICAL TRIAL NOTICES FOR THE PURPOSE OF RECRUITING PATIENTS FOR PARTICIPATION IN CLINICAL TRIALS FOR THE TESTING OF DRUGS; RENTAL OF ADVERTISEMENT SPACE AND ADVERTISING MATERIAL; RENTAL OF ADVERTISING SPACE; RENTAL OF ADVERTISING SPACE ON WEB SITES; RENTAL OF SIGNS FOR ADVERTISING PURPOSES; RENTING OF ADVERTISING SPACES; SERVICES TO DETERMINE THE AUDIENCE AFFECTED BY ADVERTISEMENTS; SPECIALTY MERCHANDISING SERVICES, NAMELY, PROMOTING THE GOODS AND SERVICES OF OTHERS THROUGH THE DISTRIBUTION OF CUSTOMIZED ADVERTISING MATERIALS, NAMELY, PENS AND PRINTED CATALOGS; TELEVISION ADVERTISING AGENCIES; VENDOR-ON-PREMISE SERVICES, NAMELY, THE ADMINISTRATION OF THE EMPLOYMENT PROCESS ON-SITE, INCLUDING RESUME REVIEW AND CHECKING, EMPLOYMENT APPLICATION ACQUISITION, ADVERTISING FOR RECRUITMENT, CONDUCT OF INTERVIEWS, AND REFERENCE CHECKING (U.S. CLS. 100, 101 AND 102).  
FIRST USE 10-14-2009; IN COMMERCE 12-31-2010.

3,941,278. THE HEART EXCHANGE, LLC, BRIARCLIFF MANOR, NY. SN 77-743,862. PUB. 7-13-2010, FILED 5-25-2009.

## Get Financed

THE MARK CONSISTS OF STANDARD CHARACTERS WITHOUT CLAIM TO ANY PARTICULAR FONT, STYLE, SIZE, OR COLOR.

NO CLAIM IS MADE TO THE EXCLUSIVE RIGHT TO USE "FINANCED", APART FROM THE MARK AS SHOWN. FOR PROVIDING ADVERTISING SERVICE TO DISTRIBUTE ADVERTISEMENTS FOR DISPLAY ON INTERNET, NAMELY, IN WEBSITES, SOCIAL CONVERSATIONS OVER THE INTERNET, EMAILS, MICROBLOGS, BLOGS, ELECTRONIC MESSAGES, INSTANT MESSAGES, TEXT MESSAGES, MULTIMEDIA MESSAGES, SOCIAL NETWORKS, STATUS UPDATES, FORUMS, ELECTRONIC BULLETIN BOARDS; ADVERTISEMENT HOARDING RENTAL; ADVERTISING AGENCIES; ADVERTISING AGENCIES PROVIDING THE STRATEGY, DESIGN AND EXECUTION OF PROGRAMS TO PROMOTE BUSINESSES IN THE FOOD AND FOOD SERVICE INDUSTRIES; ADVERTISING AGENCIES, NAMELY, PROMOTING THE GOODS AND SERVICES OF OTHERS; ADVERTISING AGENCIES, NAMELY, PROMOTING THE SERVICES OF FINANCIAL ADVERTISING SERVICES THROUGH THE DISTRIBUTION OF PRINTED AND AUDIO PROMOTIONAL MATERIALS AND BY RENDERING SALES PROMOTION ADVICE; ADVERTISING AGENCY SPECIALIZING IN THE DESIGN AND EXECUTION OF WORD OF MOUTH, VIRAL, BUZZ AND EXPERIENTIAL MARKETING PROGRAMS; ADVERTISING AND ADVERTISEMENT SERVICES; ADVERTISING AND BUSINESS ADVICE RELATING TO TELEMATICS' SERVICES; ADVERTISING AND BUSINESS MANAGEMENT CONSULTANCY; ADVERTISING AND BUSINESS SERVICES, NAMELY, SECURING AIRTIME ON ALL FORMS OF MEDIA COMMUNICATIONS STATIONS, SYSTEMS, NETWORKS, AND SERVICES FOR THE PURPOSE OF PROMOTING THE GOODS AND SERVICES OF OTHERS; ADVERTISING AND COMMERCIAL INFORMATION SERVICES, VIA THE INTERNET; ADVERTISING AND DIRECTORY SERVICES, NAMELY, PROMOTING THE SERVICES OF OTHERS BY PROVIDING A WEB PAGE FEATURING LINKS TO THE

**CLASS 35—(Continued).**

WEBSITES OF OTHERS; ADVERTISING AND MARKETING; ADVERTISING AND MARKETING SERVICES, NAMELY, PROMOTING THE GOODS AND SERVICES OF OTHERS; ADVERTISING AND PROMOTING THE GOODS AND SERVICES OF A VISUAL ARTIST; ADVERTISING AND PROMOTION SERVICES AND RELATED CONSULTING; ADVERTISING AND PROMOTIONAL SERVICES; ADVERTISING AND PUBLICITY SERVICES; ADVERTISING AND PUBLICITY SERVICES, NAMELY, PROMOTING THE GOODS, SERVICES, BRAND IDENTITY AND COMMERCIAL INFORMATION AND NEWS OF THIRD PARTIES THROUGH PRINT, AUDIO, VIDEO, DIGITAL AND ON-LINE MEDIUM; ADVERTISING BUSINESS ESPECIALLY IN THE FIELD OF TELEMATIC AND TELEPHONE NETWORKS; ADVERTISING BY TRANSMISSION OF ON-LINE PUBLICITY FOR THIRD PARTIES THROUGH ELECTRONIC COMMUNICATIONS NETWORKS; ADVERTISING CONSULTATION; ADVERTISING FLYER DISTRIBUTION; ADVERTISING PARTICULARLY SERVICES FOR THE PROMOTION OF GOODS; ADVERTISING RELATING TO PHARMACEUTICAL PRODUCTS AND IN-VIVO IMAGING PRODUCTS; ADVERTISING SERVICES; ADVERTISING SERVICES FOR PROMOTING THE BROKERAGE OF STOCKS AND OTHER SECURITIES; ADVERTISING SERVICES OF A RADIO AND TELEVISION ADVERTISING AGENCY; ADVERTISING SERVICES RELATING TO SANDWICHES; ADVERTISING SERVICES, FOR THIRD PARTIES, IN CONNECTION WITH THE COMMERCIALIZATION AND SALE OF PERFUMERY AND COSMETIC ARTICLES, PRODUCTS FOR HOUSEHOLD PURPOSES, OPTICAL PRODUCTS, CLOCKS AND TIMEPIECES, JEWELLERY, FURNISHING ARTICLES; ADVERTISING SERVICES, NAMELY, COST-PER-ACTION ON-LINE ADVERTISING; ADVERTISING SERVICES, NAMELY, CREATING CORPORATE AND BRAND IDENTITY FOR OTHERS; ADVERTISING SERVICES, NAMELY, CREATING CORPORATE LOGOS FOR OTHERS; ADVERTISING SERVICES, NAMELY, PRODUCTION OF SPECIAL EFFECTS INCLUDING MODEL-MAKING SERVICES, COMPUTER-GENERATED IMAGERY AND COMPUTER-GENERATED GRAPHICS FOR THE PRODUCTION OF COMMERCIALS; ADVERTISING SERVICES, NAMELY, PROMOTING AND MARKETING THE GOODS AND SERVICES OF OTHERS IN THE FIELD OF UPSCALE CHOICES SUCH AS CULTURAL EVENTS, RESTAURANTS, SHOPPING, AND TRAVEL VIA PRINT AND ELECTRONIC MEDIA; ADVERTISING SERVICES, NAMELY, PROMOTING AND MARKETING THE GOODS AND SERVICES OF OTHERS THROUGH ALL PUBLIC COMMUNICATION MEANS; ADVERTISING SERVICES, NAMELY, PROMOTING CAR DEALERSHIPS OF OTHERS; ADVERTISING SERVICES, NAMELY, PROMOTING PROPERTIES FOR SALE BY OWNER VIA THE INTERNET; ADVERTISING SERVICES, NAMELY, PROMOTING THE BOOKS OF OTHERS IN THE FIELD OF LAW BY MEANS OF NEWS AND REVIEWS REGARDING SAME; ADVERTISING SERVICES, NAMELY, PROMOTING THE FOOD AND WINE OF OTHERS; ADVERTISING SERVICES, NAMELY, PROMOTING THE GIFT CARDS OF OTHERS; ADVERTISING SERVICES, NAMELY, PROMOTING THE SANDWICHES OF OTHERS; ADVERTISING SERVICES, NAMELY, PROVIDING A WEBSITE FOR THE PROMOTION OF THE BOOKS OF OTHERS IN THE FIELD OF LAW, INCLUDING NEWS AND REVIEWS REGARDING SAME; ADVERTISING SERVICES, NAMELY, PROVIDING ADVERTISING SPACE IN A PERIODICAL; ADVERTISING SERVICES, NAMELY, PROVIDING INFORMATION AS TO THE AVAILABILITY OF BUSINESS SERVICES FOR RENT OR PURCHASE; ADVERTISING SERVICES, PUBLIC RELATIONS AND MARKETING SERVICES, NAMELY, PROMOTING AND MARKETING THE GOODS AND SERVICES OF OTHERS THROUGH ALL PUBLIC COMMUNICATION MEANS; ADVERTISING TEXT PUBLICATION SERVICES; ADVERTISING THROUGH ALL PUBLIC COMMUNICATION MEANS; ADVERTISING VIA ELECTRONIC MEDIA AND SPECIFICALLY THE INTERNET; ADVERTISING, INCLUDING PROMOTION OF PRODUCTS AND SERVICES OF THIRD PARTIES THROUGH SPONSORING ARRANGEMENTS AND LICENSE AGREEMENTS RELATING TO INTERNATIONAL SPORTS' EVENTS; ADVERTISING, INCLUDING PROMOTION RELATING TO THE SALE OF ARTICLES AND SERVICES FOR THIRD PARTIES BY THE TRANSMISSION OF ADVERTISING MATERI-

**CLASS 35—(Continued).**

AL AND THE DISSEMINATION OF ADVERTISING MESSAGES ON COMPUTER NETWORKS; ADVERTISING, MARKETING AND PROMOTING THE GOODS AND SERVICES OF OTHERS USING KIOSKS; ADVERTISING, MARKETING AND PROMOTION SERVICES; ADVERTISING, MARKETING AND PROMOTIONAL SERVICES FOR AUTOMOTIVE DEALERSHIPS; ADVERTISING, MARKETING AND PROMOTIONAL SERVICES FOR LIGHT AND HEAVY EQUIPMENT DEALERSHIPS; ADVERTISING, MARKETING AND PROMOTIONAL SERVICES FOR THE DONATION OF HUMAN BLOOD THAT EXACTLY MATCHES THE BLOOD TYPE OF INDIVIDUALS NEEDING TRANSFUSIONS; ADVERTISING, MARKETING AND PROMOTIONAL SERVICES RELATED TO ALL INDUSTRIES FOR THE PURPOSE OF FACILITATING NETWORKING AND SOCIALIZING OPPORTUNITIES FOR BUSINESS PURPOSES; ADVERTISING, PROMOTION AND MARKETING SERVICES IN THE NATURE OF E-MAIL BLAST CAMPAIGNS FOR OTHERS; AGENCIES FOR ADVERTISING TIME AND SPACE; ANALYSIS OF ADVERTISING RESPONSE; ARRANGING AND CONDUCTING OF FAIRS AND EXHIBITIONS FOR BUSINESS AND ADVERTISING PURPOSES; BUSINESS MANAGEMENT AND CONSULTING SERVICES FOR THE HEALTH CARE INDUSTRY, NAMELY, CUSTOMER SERVICE, ACCOUNTING SERVICES, AND WEB-BASED ADVERTISING AND MARKETING SERVICES; CINEMA ADVERTISING; COMPILATION OF ADVERTISEMENTS FOR USE AS WEB PAGES ON THE INTERNET; CONSUMER LOYALTY SERVICES FOR COMMERCIAL, PROMOTIONAL, AND/OR ADVERTISING PURPOSES, NAMELY, ADMINISTRATION OF FREQUENT FLYER PROGRAM THAT ALLOWS MEMBERS TO REDEEM MILES FOR POINTS OR AWARDS OFFERED BY OTHER LOYALTY PROGRAMS; COOPERATIVE ADVERTISING AND MARKETING; COOPERATIVE ADVERTISING AND MARKETING SERVICES BY WAY OF SOLICITATION, CUSTOMER SERVICE AND PROVIDING MARKETING INFORMATION VIA WEB SITES ON A GLOBAL COMPUTER NETWORK; CREATING AND UPDATING ADVERTISING MATERIAL; CREATION OF MARKETING TOOLS DESIGNED TO INCREASE A CLIENT COMPANY'S KNOWLEDGE OF CUSTOMER NEEDS, AND ITS COMPETITORS' PRODUCTS AND SERVICES, PRICING, ADVERTISING STRATEGY AND SALES STRATEGY; CUSTOMER LOYALTY SERVICES AND CUSTOMER CLUB SERVICES, FOR COMMERCIAL, PROMOTIONAL AND/OR ADVERTISING PURPOSES; DESIGN OF ADVERTISING FLYERS FOR OTHERS; DESIGN OF ADVERTISING MATERIALS FOR OTHERS; DESIGN OF INTERNET ADVERTISING; DEVELOPMENT, OPERATION AND ADMINISTRATION OF DIGITAL SIGNAGE SYSTEMS AND DIGITAL ADVERTISING SYSTEMS FOR OTHERS, NAMELY, PROVIDING ADVERTISING SPACE BY ELECTRONIC MEANS AND GLOBAL COMPUTER INFORMATION NETWORKS; DIRECT MAIL ADVERTISING; DIRECT MARKETING ADVERTISING FOR OTHERS; DISPLAYING ADVERTISEMENTS FOR OTHERS; DISSEMINATION OF ADVERTISEMENTS; DISSEMINATION OF ADVERTISEMENTS AND OF ADVERTISING MATERIAL; DISSEMINATION OF ADVERTISING FOR OTHERS VIA AN ON-LINE COMMUNICATIONS NETWORK ON THE INTERNET; DISSEMINATION OF ADVERTISING FOR OTHERS VIA THE INTERNET; DISSEMINATION OF ADVERTISING MATERIAL; DISSEMINATION OF ADVERTISING MATTER; DISSEMINATION OF ADVERTISING, SCHEDULING AND MANAGING OF TRAINING COURSES AND PROGRAMS FOR OTHERS VIA A GLOBAL COMPUTER NETWORK; DISTRIBUTION AND DISSEMINATION OF ADVERTISING MATERIALS; DISTRIBUTION OF ADVERTISEMENTS AND COMMERCIAL ANNOUNCEMENTS; DISTRIBUTION OF ADVERTISING MAIL AND OF ADVERTISING SUPPLEMENTS ATTACHED TO REGULAR EDITIONS; DISTRIBUTION OF PRODUCTS FOR ADVERTISING PURPOSES; ELECTRONIC BILLBOARD ADVERTISING; ELECTRONIC COMMERCE SERVICES, NAMELY, PROVIDING INFORMATION ABOUT PRODUCTS VIA TELECOMMUNICATION NETWORKS FOR ADVERTISING AND SALES PURPOSES; ENTERTAINMENT MARKETING SERVICES, NAMELY, MARKETING, PROMOTION AND ADVERTISING FOR INDEPENDENT RECORDING ARTISTS; INTERNET ADVERTISING SERVICES; ISSUING AND UPDATING OF ADVERTISING TEXTS; LAYOUT SERVICES FOR ADVERTISING PURPOSES; MARKETING

**CLASS 35—(Continued).**

AND ADVERTISING SERVICES FOR AUTOMOBILE DEALERSHIPS; MARKETING, ADVERTISING AND PROMOTING THE GOODS AND SERVICES OF OTHERS IN THE FIELD OF TRAVEL AND TOURISM, NAMELY, PROVIDING INFORMATION VIA MAIL AND ELECTRONIC MAIL; MARKETING, ADVERTISING, AND PROMOTING THE RETAIL GOODS AND SERVICES OF OTHERS TO WIRELESS ELECTRONIC DEVICES; MARKETING, PROMOTIONAL AND ADVERTISING SERVICES PROVIDED BY MOBILE TELEPHONE CONNECTIONS; MEDIA BUYING ADVICE, NAMELY, ADVISING THE CLIENT HOW MUCH MEDIA TIME, AND AT WHAT TIMES THE CLIENT SHOULD BE PURCHASING ADVERTISING; MEDIA PLANNING, NAMELY, ADVISING THE CLIENT ON THE CORRECT TIMES AND STATIONS TO ADVERTISE BASED ON MEDIA ANALYSIS OF THE MARKET FOR THAT MEDIA; MEDIA PRODUCTION LOCATION SCOUTING SERVICES FOR ADVERTISING PURPOSES; MEDIATION OF ADVERTISING; MODELING FOR ADVERTISING OR SALES PROMOTION; MODELING SERVICES FOR ADVERTISING OR SALES PROMOTION; MUSIC SELECTION SERVICES FOR USE IN ADVERTISING; ON-LINE ADVERTISING AND MARKETING SERVICES; ON-LINE ADVERTISING ON COMPUTER COMMUNICATION NETWORKS; ON-LINE ADVERTISING SERVICES FOR OTHERS; ORGANIZATION AND HOLDING OF FAIRS FOR COMMERCIAL OR ADVERTISING PURPOSES; ORGANIZING EXHIBITIONS FOR FINANCIAL COMMERCIAL OR ADVERTISING PURPOSES; ORGANIZATION OF EVENTS, EXHIBITIONS, FAIRS AND SHOWS FOR COMMERCIAL, PROMOTIONAL AND ADVERTISING PURPOSES; ORGANIZATION OF FAIRS FOR COMMERCIAL AND ADVERTISING PURPOSES; ORGANIZING BUSINESS EXPOSITIONS FOR FINANCIAL BUSINESS SERVICES; ORGANIZING EXHIBITIONS FOR COMMERCIAL OR ADVERTISING PURPOSES; ORGANIZING EXHIBITIONS FOR FINANCIAL BUSINESS SERVICES; OUT-OF-HOME ADVERTISING SERVICES, NAMELY, RENTAL OF ADVERTISING SPACE, AND PREPARING AND PLACING ADVERTISEMENTS FOR OTHERS; PAY PER CLICK (PPC) ADVERTISING MANAGEMENT SERVICES; PLACING ADVERTISEMENTS FOR OTHERS; PLANNING AND CONDUCTING OF TRADE FAIRS, EXHIBITIONS AND PRESENTATIONS FOR ECONOMIC OR ADVERTISING PURPOSES; PREPARATION AND REALIZATION OF MEDIA AND ADVERTISING PLANS AND CONCEPTS; PREPARATION OF CUSTOM ADVERTISEMENTS FOR OTHERS; PREPARATION OF CUSTOM OR NON-CUSTOM ADVERTISING FOR BUSINESSES FOR DISSEMINATION VIA THE WEB, CD OR DVD FOR OPTIONAL UPLOAD OR DOWNLOAD TO A COMPUTER; PREPARING ADVERTISEMENTS FOR OTHERS; PREPARING AND PLACING ADVERTISEMENTS FOR OTHERS; PREPARING AND PLACING OF ADVERTISEMENTS; PREPARING AND PLACING OUTDOOR ADVERTISEMENTS FOR OTHERS; PREPARING AUDIOVISUAL DISPLAYS IN THE FIELD OF BUSINESS SERVICES; PREPARING AUDIOVISUAL PRESENTATIONS FOR USE IN ADVERTISING; PREPARING SPEECHES AND ORAL PRESENTATIONS FOR OTHERS FOR USE IN ADVERTISING; PROCESSING TELEPHONE INQUIRIES REGARDING ADVERTISED GOODS AND SERVICES; PRODUCTION OF ADVERTISING MATTER AND COMMERCIALS; PRODUCTION OF FILM AND TELEVISION ADVERTISING; PROMOTING THE GOODS AND SERVICES OF OTHERS BY DISTRIBUTING ADVERTISING MATERIALS THROUGH A VARIETY OF METHODS; PROMOTING THE GOODS AND SERVICES OF OTHERS BY MEANS OF DISTRIBUTING ADVERTISING ON THE INTERNET; PROMOTING THE GOODS AND SERVICES OF OTHERS BY PREPARING AND PLACING ADVERTISEMENTS IN AN ELECTRONIC MAGAZINE ACCESSED THROUGH A GLOBAL COMPUTER NETWORK; PROMOTING, ADVERTISING AND MARKETING OF THE ON-LINE WEB SITES OF OTHERS; PROMOTION, ADVERTISING AND MARKETING OF ON-LINE WEBSITES; PROMOTIONAL SERVICES, NAMELY, DISTRIBUTION OF ADVERTISING FLYERS, COUPONS, CATALOGS AND PROMOTIONAL ITEMS OF OTHERS; PROVIDING A SEARCHABLE ON-LINE ADVERTISING WEBSITE AND GUIDE FEATURING THE GOODS AND SERVICES OF OTHER VENDORS VIA THE INTERNET; PROVIDING A SEARCHABLE ONLINE ADVERTISING GUIDE FEATURING THE GOODS AND SERVICES OF OTHER ON-LINE VEN-

**CLASS 35—(Continued).**

DORS ON THE INTERNET; PROVIDING A WEB SITE AT WHICH FITNESS PROFESSIONALS AND FACILITIES CAN POST PROMOTIONAL PROFILES AND RESPOND TO ADVERTISEMENTS FOR THEIR SERVICES; PROVIDING A WEB SITE THAT ENABLES USERS TO POST ITEMS FOR SALE THROUGH ON-LINE CLASSIFIED ADVERTISEMENTS; PROVIDING A WEB SITE WHICH FEATURES ADVERTISEMENTS FOR THE GOODS AND SERVICES OF OTHERS ON A GLOBAL COMPUTER NETWORK; PROVIDING ADVERTISING AND ADVERTISEMENT SERVICES; PROVIDING ADVERTISING SERVICES; PROVIDING ADVERTISING SERVICES USING 3D AND ANIMATION DESIGNS; PROVIDING ADVERTISING SPACE IN PERIODICALS, NEWSPAPERS AND MAGAZINES; PROVIDING ADVERTISING SPACE ON BILLBOARDS AND IN KIOSKS; PROVIDING ADVERTISING SPACE ON FREE-STANDING VISUAL ADVERTISING SYSTEMS FEATURING THE GOODS AND SERVICES OF OTHERS; PROVIDING ADVERTISING, MARKETING AND PROMOTIONAL SERVICES RELATED TO FINANCE FOR THE PHARMACEUTICAL AND MEDICAL INDUSTRY; PROVIDING ADVERTISING, MARKETING AND PROMOTIONAL SERVICES RELATED TO FINANCE FOR THE PHARMACEUTICAL AND MEDICAL PRODUCTS OF OTHERS; PROVIDING ADVERTISING, MARKETING AND PROMOTIONAL SERVICES, NAMELY, FINANCIAL BUSINESS SERVICES; PROVIDING AN INTERNET WEB SITE FOR CLASSIFIED ADVERTISING TO BUY AND SELL UKRAINIAN RELATED WARES, ART, ANTIQUES, BOOKS, EMBROIDERY, COSTUMES, COLLECTIBLES, INSTRUMENTS, MEMORABILIA AND OTHER ONE-OF-A-KIND ITEMS; PROVIDING AN INTERNET WEB SITE TO ADVERTISE SERVICES OF INTEREST TO THE UKRAINIAN COMMUNITY IN THE UNITED STATES OF AMERICA AND CANADA AND TO ADVERTISE SERVICES PROVIDED BY INDIVIDUALS OF UKRAINIAN ORIGIN; PROVIDING AND RENTAL OF ADVERTISING SPACE ON THE INTERNET; PROVIDING SPACE AT A WEB SITE FOR THE ADVERTISEMENT OF THE GOODS AND SERVICES OF OTHERS; PROVIDING TELEVISION ADVERTISING FOR OTHERS; PROVISION OF ADVERTISING SPACE BY ELECTRONIC MEANS AND GLOBAL INFORMATION NETWORKS; PROVISION OF SPACE ON WEBSITES FOR ADVERTISING GOODS AND SERVICES; PUBLIC RELATIONS, ADVERTISING AND MARKETING SERVICES FOR THE TOURISM AND CONVENTION INDUSTRY, NAMELY, ORGANIZING AND HOSTING SITE INSPECTIONS AND FAMILIARIZATION TOURS FOR WHOLESALERS, TOUR OPERATORS, TRAVEL AGENTS, MEETING AND INCENTIVE TRAVEL PLANNERS AND TRAVEL MEDIA; PUBLISHING OF ADVERTISING TEXTS; REAL ESTATE ADVERTISING SERVICES; RECRUITMENT ADVERTISEMENT SERVICES, NAMELY, POSTING OF CLINICAL TRIAL NOTICES FOR THE PURPOSE OF RECRUITING PATIENTS FOR PARTICIPATION IN CLINICAL TRIALS FOR THE TESTING OF DRUGS; RENTAL OF ADVERTISEMENT SPACE AND ADVERTISING MATERIAL; RENTAL OF ADVERTISING SPACE; RENTAL OF ADVERTISING SPACE ON WEB SITES; RENTAL OF SIGNS FOR ADVERTISING PURPOSES; RENTING OF ADVERTISING SPACES; SERVICES TO DETERMINE THE AUDIENCE AFFECTED BY ADVERTISEMENTS; SPECIALTY MERCHANDISING SERVICES, NAMELY, PROMOTING THE GOODS AND SERVICES OF OTHERS THROUGH THE DISTRIBUTION OF CUSTOMIZED ADVERTISING MATERIALS, NAMELY, PENS AND PRINTED CATALOGS; TELEVISION ADVERTISING AGENCIES; VENDOR-ON-PREMISE SERVICES, NAMELY, THE ADMINISTRATION OF THE EMPLOYMENT PROCESS ON-SITE, INCLUDING RESUME REVIEW AND CHECKING, EMPLOYMENT APPLICATION ACQUISITION, ADVERTISING FOR RECRUITMENT, CONDUCT OF INTERVIEWS, AND REFERENCE CHECKING (U.S. CLS. 100, 101 AND 102).

FIRST USE 10-14-2009; IN COMMERCE 12-31-2010.

**CLASS 35—(Continued).**

3,941,284. INFORMATIVE DESIGN GROUP, INC., DBA THE HISTORY FACTORY, CHANTILLY, VA. SN 77-751,947. PUB. 5-25-2010, FILED 6-4-2009.

## StoryArc

THE MARK CONSISTS OF STANDARD CHARACTERS WITHOUT CLAIM TO ANY PARTICULAR FONT, STYLE, SIZE, OR COLOR.

FOR BUSINESS MANAGEMENT CONSULTANCY AND ADVISORY SERVICES; ADVISORY SERVICES PROVIDED TO BUSINESSES REGARDING THE PROMOTION OF THE GOODS, SERVICES, BRAND IDENTITY, HISTORY, AND COMMERCIAL INFORMATION AND NEWS OF THIRD PARTIES THROUGH PRINT, AUDIO, VIDEO, DIGITAL AND ON-LINE MEDIA; ADVISORY SERVICES IN THE FIELD OF BUSINESS MANAGEMENT NARRATIVE TECHNIQUES (U.S. CLS. 100, 101 AND 102).

FIRST USE 8-4-2009; IN COMMERCE 8-4-2009.

3,941,292. SHELL TRADEMARK MANAGEMENT BV, THE HAGUE, NETHERLANDS. SN 77-755,380. PUB. 4-27-2010, FILED 6-9-2009.



THE COLOR(S) RED, WHITE, YELLOW, AND BLUE IS/ARE CLAIMED AS A FEATURE OF THE MARK.

THE MARK CONSISTS OF THE WORD "AERO" IN A BOLD BLUE FONT FOLLOWED BY THE WORD "CLASS", IN A REGULAR BLUE FONT. THE WORD "CLASS" HAS A SLIGHT SLANT TO THE RIGHT. THE WORD "SHELL" IS IN A RED FONT AND LOCATED ABOVE THE WORD "AERO". THREE YELLOW CIRCULAR SWIRLS OF VARYING LENGTHS ARE LOCATED ABOVE AND TO THE RIGHT OF THE WORD "CLASS", WITH THREE BLUE FOUR-POINTED STARS INTERSECTING THE SWIRLS.

FOR PROVIDING AN INCENTIVE AWARD PROGRAM FOR CUSTOMERS THROUGH THE DISTRIBUTION OF STORED VALUE CARDS FOR THE PURPOSE OF PROMOTING AND REWARDING LOYALTY (U.S. CLS. 100, 101 AND 102).

FIRST USE 10-29-2009; IN COMMERCE 10-29-2009.

**CLASS 35—(Continued).**

3,941,295. SHELL TRADEMARK MANAGEMENT BV, THE HAGUE, NETHERLANDS. SN 77-755,630. PUB. 4-27-2010, FILED 6-9-2009.

## SHELL AEROCLASS

THE MARK CONSISTS OF STANDARD CHARACTERS WITHOUT CLAIM TO ANY PARTICULAR FONT, STYLE, SIZE, OR COLOR.

FOR PROVIDING AN INCENTIVE AWARD PROGRAM FOR CUSTOMERS THROUGH THE DISTRIBUTION OF STORED VALUE CARDS FOR THE PURPOSE OF PROMOTING AND REWARDING LOYALTY (U.S. CLS. 100, 101 AND 102).

FIRST USE 10-29-2009; IN COMMERCE 10-29-2009.

3,941,296. BEZOOM USA, LLC, ARLINGTON, VA. SN 77-756,543. PUB. 7-27-2010, FILED 6-10-2009.

## BEZOOM

THE MARK CONSISTS OF STANDARD CHARACTERS WITHOUT CLAIM TO ANY PARTICULAR FONT, STYLE, SIZE, OR COLOR.

FOR COMMERCIAL ADVERTISEMENT SERVICES, NAMELY, PRODUCTION OF ADVERTISING MATTER AND COMMERCIALS IN THE NATURE OF SHORT VIDEOS TO BE DOWNLOADED FROM THE CUSTOMERS' WEBSITES AND OTHER MEANS (U.S. CLS. 100, 101 AND 102).

FIRST USE 5-10-2009; IN COMMERCE 5-10-2009.

3,941,343. LF, LLC, MOUNT MOURNE, NC. SN 77-773,320. PUB. 10-13-2009, FILED 7-2-2009.

## LOWE'S CREATIVE IDEAS

THE MARK CONSISTS OF STANDARD CHARACTERS WITHOUT CLAIM TO ANY PARTICULAR FONT, STYLE, SIZE, OR COLOR.

**CLASS 35—(Continued).**

OWNER OF U.S. REG. NOS. 1,931,270, 3,034,244, AND OTHERS.

FOR RETAIL STORE SERVICES FEATURING GOODS IN THE FIELDS OF HOME IMPROVEMENT, BUILDING PRODUCTS, SEASONAL LIVING, NAMELY, OUTDOOR FURNITURE, GRILLS AND GRILL ACCESSORIES, HOLIDAY DECORATIONS AND LAWN AND GARDEN TOOLS, LAWN AND LANDSCAPE, NURSERY, FLOORING, HOME ORGANIZATION, PAINT, APPLIANCES, PLUMBING AND HARDWARE (U.S. CLS. 100, 101 AND 102).

FIRST USE 12-0-1998; IN COMMERCE 12-0-1998.

3,941,348. THEFIND, INC., MOUNTAIN VIEW, CA. SN 77-775,703. PUB. 6-15-2010, FILED 7-7-2009.

# UPFRONT

THE MARK CONSISTS OF STANDARD CHARACTERS WITHOUT CLAIM TO ANY PARTICULAR FONT, STYLE, SIZE, OR COLOR.

FOR PROVIDING ONLINE BUSINESS DIRECTORIES REGARDING INTERNET MERCHANTS THAT HAVE BEEN CERTIFIED AS ENTITIES THAT ADHERE TO A SET OF GOOD BUSINESS STANDARDS; PROVIDING ONLINE INFORMATION ABOUT THE GOODS AND SERVICES OF OTHERS; ADVERTISING AND ADVERTISEMENT SERVICES, NAMELY, PROMOTING THE SALE OF GOODS AND SERVICES OF OTHERS; PROVIDING CONSUMER PRODUCT AND SHOPPING INFORMATION TO OTHERS THROUGH A WEBSITE THAT ALLOWS CONSUMERS TO SEARCH AND COMPARISON SHOP FOR PRODUCTS BY FEATURING PRODUCT INFORMATION, PRODUCT PHOTOS AND HYPERLINKS TO OTHER WEBSITES (U.S. CLS. 100, 101 AND 102).

FIRST USE 6-16-2009; IN COMMERCE 6-16-2009.

3,941,356. REALCME, INC., NEW YORK, NY. SN 77-778,187. PUB. 12-8-2009, FILED 7-10-2009.

# REALMEASURE

THE MARK CONSISTS OF STANDARD CHARACTERS WITHOUT CLAIM TO ANY PARTICULAR FONT, STYLE, SIZE, OR COLOR.

FOR ANALYZING AND COMPILING DATA FOR MEASURING THE PERFORMANCE OF MEDICAL EDUCATION ACTIVITIES AND CURRICULUM (U.S. CLS. 100, 101 AND 102).

FIRST USE 9-0-2009; IN COMMERCE 9-0-2009.

**CLASS 35—(Continued).**

3,941,358. THE INNOVISION GROUP, L.L.C., ASHEBORO, NC. SN 77-779,267. PUB. 12-8-2009, FILED 7-13-2009.

# GROOVYSCAVENGER

THE MARK CONSISTS OF STANDARD CHARACTERS WITHOUT CLAIM TO ANY PARTICULAR FONT, STYLE, SIZE, OR COLOR.

FOR COMPUTERIZED ON-LINE RETAIL STORE SERVICES IN THE FIELD OF FURNITURE; ON-LINE RETAIL STORE SERVICES FEATURING FURNITURE; RETAIL FURNITURE STORES (U.S. CLS. 100, 101 AND 102).

FIRST USE 3-31-2010; IN COMMERCE 3-31-2010.

3,941,393. SBIM CONSULTING LLC, COLUMBIA, MD. SN 77-794,842. PUB. 1-5-2010, FILED 7-31-2009.

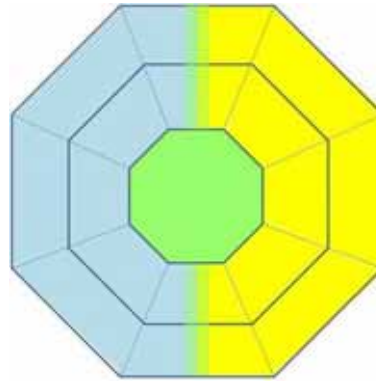

THE COLOR(S) BLUE, GREEN, YELLOW IS/ARE CLAIMED AS A FEATURE OF THE MARK.

THE MARK CONSISTS OF AN OCTAGON SHAPE WITH THREE LAYERS AND EIGHT LINES FROM THE OUTER LAYER TO THE OUTSIDE OF THE INNER LAYER EACH SEGMENT IS OUTLINED IN A BLUE LINE. THE INNER LAYER IS GREEN. THE AREA BETWEEN THE OUTER LAYER AND INNER LAYER IS BLUE ON THE LEFT AND YELLOW ON THE RIGHT. THERE IS ALSO A BAND OF GREEN BETWEEN THE BLUE AND YELLOW PORTIONS OF THE GRAPHIC.

FOR BUSINESS CONSULTING AND MANAGEMENT IN THE FIELD OF CLINICAL TRIALS, NAMELY, PROVIDING INFORMATION MANAGEMENT SERVICES; BUSINESS INFORMATION MANAGEMENT; BUSINESS INFORMATION MANAGEMENT, NAMELY, ELECTRONIC REPORTING OF BUSINESS INFORMATION, BUSINESS ANALYTICS, NAMELY, BUSINESS INVESTIGATIONS, EVALUATIONS, EXPERT APPRAISALS, INFORMATION AND RESEARCH, TRADE SPEND BUSINESS MANAGEMENT (U.S. CLS. 100, 101 AND 102).

FIRST USE 3-1-2009; IN COMMERCE 1-1-2010.

**CLASS 35—(Continued).**

3,941,403. HESS CORPORATION, NEW YORK, NY. SN 77-797,206. PUB. 6-22-2010, FILED 8-5-2009.

**HESS ENERGY**

THE MARK CONSISTS OF STANDARD CHARACTERS WITHOUT CLAIM TO ANY PARTICULAR FONT, STYLE, SIZE, OR COLOR.

OWNER OF U.S. REG. NOS. 3,310,764, 3,334,717, AND 3,394,038.

NO CLAIM IS MADE TO THE EXCLUSIVE RIGHT TO USE "ENERGY", APART FROM THE MARK AS SHOWN.

SEC. 2(F) AS TO "HESS".

FOR MARKETING CONSULTING AS TO NATURAL GAS, ELECTRICITY, MOTOR OIL AND FUEL (U.S. CLS. 100, 101 AND 102).

FIRST USE 4-0-2010; IN COMMERCE 4-0-2010.

3,941,409. LANGSFELD & ASSOCIATES, LTD., INCLINE VILLAGE, NV. SN 77-800,378. PUB. 7-6-2010, FILED 8-9-2009.

**RATESCOUT**

THE MARK CONSISTS OF STANDARD CHARACTERS WITHOUT CLAIM TO ANY PARTICULAR FONT, STYLE, SIZE, OR COLOR.

FOR PROVIDING HOTEL RATE COMPARISON INFORMATION TO ASSIST THE CLIENT IN LOCATING THE BEST ROOM RATE (U.S. CLS. 100, 101 AND 102).

FIRST USE 7-20-2009; IN COMMERCE 7-20-2009.

3,941,410. LANGSFELD & ASSOCIATES, LTD., INCLINE VILLAGE, NV. SN 77-800,379. PUB. 7-6-2010, FILED 8-9-2009.

**RATEGUARD**

THE MARK CONSISTS OF STANDARD CHARACTERS WITHOUT CLAIM TO ANY PARTICULAR FONT, STYLE, SIZE, OR COLOR.

FOR AUDITING THE PRICING OF HOTEL ROOMS TO ENSURE THAT THE PRE-NEGOTIATED ROOM RATE IS HONORED (U.S. CLS. 100, 101 AND 102).

FIRST USE 7-20-2009; IN COMMERCE 7-0-2009.

**CLASS 35—(Continued).**

3,941,427. NATIONAL ASSOCIATION OF MUSIC MERCHANTS, INC., CARLSBAD, CA. SN 77-806,076. PUB. 6-22-2010, FILED 8-17-2009.

**WANNA PLAY?**

THE MARK CONSISTS OF STANDARD CHARACTERS WITHOUT CLAIM TO ANY PARTICULAR FONT, STYLE, SIZE, OR COLOR.

OWNER OF U.S. REG. NOS. 1,862,894, 2,070,596, AND 3,606,586.

FOR PROMOTING PUBLIC AWARENESS OF MUSIC EDUCATION PROJECTS, MUSIC AND MUSICAL INSTRUMENT INSTRUCTION; PUBLIC EDUCATION CAMPAIGN IN THE NATURE OF PUBLIC ADVOCACY TO PROMOTE AWARENESS OF THE IMPORTANCE OF MUSIC EDUCATION, MUSICAL INSTRUMENT INSTRUCTION AND THE BENEFITS OF PLAYING MUSIC; PROMOTION SERVICES FOR THIRD PARTIES IN THE NATURE OF ON-LINE DIRECTORIES IN THE FIELDS OF MUSIC LESSONS AND MUSIC RETAILING (U.S. CLS. 100, 101 AND 102).

FIRST USE 11-14-2006; IN COMMERCE 1-18-2007.

3,941,429. WEGOLOOK, LLC, OKLAHOMA CITY, OK. SN 77-806,996. PUB. 10-12-2010, FILED 8-18-2009.

**WeGoLookers**

THE MARK CONSISTS OF STANDARD CHARACTERS WITHOUT CLAIM TO ANY PARTICULAR FONT, STYLE, SIZE, OR COLOR.

FOR CONSUMER RESEARCH, NAMELY, CONDUCTING ON-SITE INSPECTIONS AND OBSERVATIONS OF GOODS OFFERED FOR SALE, FOR THE PURPOSE OF VERIFYING THE CONDITION OF THE PRODUCTS AND THE VERACITY OF SELLER'S CLAIMS, AND PREPARING REPORTS RELATED THERETO (U.S. CLS. 100, 101 AND 102).

FIRST USE 6-11-2010; IN COMMERCE 6-11-2010.

3,941,432. SATELLITE LOGISTICS GROUP, INC., HOUSTON, TX. SN 77-808,977. PUB. 6-1-2010, FILED 8-20-2009.

**LogiTrax**

THE MARK CONSISTS OF STANDARD CHARACTERS WITHOUT CLAIM TO ANY PARTICULAR FONT, STYLE, SIZE, OR COLOR.

FOR FREIGHT LOGISTICS MANAGEMENT SERVICES (U.S. CLS. 100, 101 AND 102).

FIRST USE 9-18-2009; IN COMMERCE 9-18-2009.



**CLASS 35—(Continued).**

3,941,434. SATELLITE LOGISTICS GROUP, INC., HOUSTON, TX. SN 77-809,006. PUB. 6-1-2010, FILED 8-20-2009.

**SIMPLEXITY SUPPLY CHAIN SOLUTIONS**

THE MARK CONSISTS OF STANDARD CHARACTERS WITHOUT CLAIM TO ANY PARTICULAR FONT, STYLE, SIZE, OR COLOR.

NO CLAIM IS MADE TO THE EXCLUSIVE RIGHT TO USE "SUPPLY CHAIN SOLUTIONS", APART FROM THE MARK AS SHOWN.

FOR BUSINESS CONSULTING SERVICES RELATING TO PRODUCT DISTRIBUTION, OPERATIONS MANAGEMENT SERVICES, LOGISTICS, REVERSE LOGISTICS, SUPPLY CHAIN AND PRODUCTION SYSTEMS, AND DISTRIBUTION SOLUTIONS (U.S. CLS. 100, 101 AND 102).

FIRST USE 9-18-2009; IN COMMERCE 9-18-2009.

3,941,448. DDB WORLDWIDE COMMUNICATIONS GROUP INC., NEW YORK, NY. SN 77-819,241. PUB. 7-6-2010, FILED 9-3-2009.

**Tribal DDB Sonar**

THE MARK CONSISTS OF STANDARD CHARACTERS WITHOUT CLAIM TO ANY PARTICULAR FONT, STYLE, SIZE, OR COLOR.

OWNER OF U.S. REG. NOS. 2,607,757, 2,867,083, AND OTHERS.

FOR MARKET RESEARCH AND ANALYSIS, AND BUSINESS DATA ANALYSIS IN THE FIELD OF CONSUMER MARKETING BEHAVIOR; BUSINESS MARKETING CONSULTING SERVICES IN THE FIELD OF CONSUMER MARKETING BEHAVIOR (U.S. CLS. 100, 101 AND 102).

FIRST USE 9-11-2009; IN COMMERCE 9-11-2009.

3,941,472. REED ELSEVIER INC., NEWTON, MA. SN 77-834,238. PUB. 8-3-2010, FILED 9-24-2009.



THE MARK CONSISTS OF "LUXURY" WITH A STYLIZED "L" OVER TOP.

**CLASS 35—(Continued).**

SEC. 2(F) "LUXURY" HAS BECOME DISTINCTIVE OF THE GOODS/SERVICES, AS DEMONSTRATED BY THE ATTACHED EVIDENCE; "LUXURY" HAS BECOME DISTINCTIVE OF THE GOODS/SERVICES THROUGH THE APPLICANT'S SUBSTANTIALLY EXCLUSIVE AND CONTINUOUS USE IN COMMERCE FOR AT LEAST THE FIVE YEARS IMMEDIATELY BEFORE THE DATE OF THIS STATEMENT.

FOR ARRANGING AND CONDUCTING TRADESHOWS AND BUSINESS CONFERENCES IN THE FIELD OF JEWELRY (U.S. CLS. 100, 101 AND 102).

FIRST USE 10-31-2005; IN COMMERCE 10-31-2005.

3,941,473. CELLCO PARTNERSHIP, DBA VERIZON WIRELESS, BASKING RIDGE, NJ. SN 77-834,398. PUB. 4-20-2010, FILED 9-24-2009.

**SPEND SMART**

THE MARK CONSISTS OF STANDARD CHARACTERS WITHOUT CLAIM TO ANY PARTICULAR FONT, STYLE, SIZE, OR COLOR.

FOR PROMOTING THE GOODS AND SERVICES OF OTHERS BY PROVIDING AN INTERACTIVE WEB SITE THAT OFFERS COUPONS, REBATES, DISCOUNTS OR SPECIAL PROMOTIONS AND OFFERS ON GOODS AND SERVICES PROVIDED BY OTHERS, AND WHICH IS ACCESSIBLE VIA A WIRELESS TELECOMMUNICATIONS DEVICE (U.S. CLS. 100, 101 AND 102).

FIRST USE 2-3-2010; IN COMMERCE 2-3-2010.

3,941,482. CENTRIS CONSULTING, INC., SCRANTON, PA. SN 77-838,615. PUB. 2-23-2010, FILED 9-30-2009.

**Reliability Assured**

THE MARK CONSISTS OF STANDARD CHARACTERS WITHOUT CLAIM TO ANY PARTICULAR FONT, STYLE, SIZE, OR COLOR.

FOR BUSINESS CONSULTING SERVICES IN THE FIELD OF RESOURCE MANAGEMENT (U.S. CLS. 100, 101 AND 102).

FIRST USE 8-15-2010; IN COMMERCE 8-15-2010.

**CLASS 35—(Continued).**

3,941,483. 9451 BECKER LANE, LLC, TEMPE, AZ. SN 77-839,126. PUB. 9-7-2010, FILED 10-1-2009.

**MERCHANTS GO GREEN**

THE MARK CONSISTS OF STANDARD CHARACTERS WITHOUT CLAIM TO ANY PARTICULAR FONT, STYLE, SIZE, OR COLOR.

NO CLAIM IS MADE TO THE EXCLUSIVE RIGHT TO USE "MERCHANTS", APART FROM THE MARK AS SHOWN.

FOR GENERAL BUSINESS NETWORKING REFERRAL SERVICES, NAMELY, PROMOTING THE GOODS AND SERVICES OF OTHERS BY PASSING BUSINESS LEADS AND REFERRALS AMONG GROUP MEMBERS (U.S. CLS. 100, 101 AND 102).

FIRST USE 11-15-2008; IN COMMERCE 11-15-2008.

---

3,941,484. CENTRIS CONSULTING, INC., SCRANTON, PA. SN 77-839,342. PUB. 2-23-2010, FILED 10-1-2009.



THE MARK CONSISTS OF THE LETTER "E3" WITHIN A BOX FRAMED BY THE WORDS "ENGINEERING EXECUTION EXCELLENCE".

FOR BUSINESS CONSULTING SERVICES IN THE FIELD OF RESOURCE MANAGEMENT (U.S. CLS. 100, 101 AND 102).

FIRST USE 9-28-2010; IN COMMERCE 9-28-2010.

**CLASS 35—(Continued).**

3,941,499. ALL-GLOBAL BUSINESS LLC, RENO, NV. SN 77-849,360. PUB. 7-27-2010, FILED 10-15-2009.



NO CLAIM IS MADE TO THE EXCLUSIVE RIGHT TO USE "INC.", APART FROM THE MARK AS SHOWN.

THE COLOR(S) BLACK, GRAY, WHITE IS/ARE CLAIMED AS A FEATURE OF THE MARK.

THE MARK CONSISTS OF A GLOBE COMPRISED OF GRAY CONTINENTS AND WHITE OCEANS OUTLINED PARTIALLY IN BLACK WITH A BLACK GRID SUPERIMPOSED OVER THE GLOBE; THE WORDS "ALL-GLOBAL INC." APPEAR IN STYLIZED BLACK FONT IN AN ARC OVER THE TOP OF THE GLOBE. THE MARK IN ITS ENTIRETY APPEARS ON A WHITE BACKGROUND.

FOR BUSINESS MANAGEMENT; BUSINESS MANAGEMENT CONSULTANCY AND ADVISORY SERVICES; BUSINESS MANAGEMENT CONSULTANCY AS WELL AS DEVELOPMENT OF PROCESSES FOR THE ANALYSIS AND THE IMPLEMENTATION OF STRATEGY PLANS AND MANAGEMENT PROJECTS; BUSINESS MANAGEMENT CONSULTANCY, ALSO VIA THE INTERNET; BUSINESS MARKETING CONSULTING SERVICES; BUSINESS NETWORKING; BUSINESS PLANNING (U.S. CLS. 100, 101 AND 102).

FIRST USE 12-3-2009; IN COMMERCE 1-21-2010.

---

3,941,500. ANDIS WINES, LLC, SUTTER CREEK, CA. SN 77-849,806. PUB. 6-22-2010, FILED 10-15-2009.

**ANDIS WINES**

THE MARK CONSISTS OF STANDARD CHARACTERS WITHOUT CLAIM TO ANY PARTICULAR FONT, STYLE, SIZE, OR COLOR.

NO CLAIM IS MADE TO THE EXCLUSIVE RIGHT TO USE "WINES", APART FROM THE MARK AS SHOWN.

FOR ON-LINE RETAIL STORE SERVICES, FEATURING WINE (U.S. CLS. 100, 101 AND 102).

FIRST USE 11-15-2010; IN COMMERCE 11-15-2010.

**CLASS 35—(Continued).**

3,941,502. CORPORATE INK, NEWTON, MA. SN 77-851,761.  
PUB. 1-19-2010, FILED 10-19-2009.

conversations that matter

THE MARK CONSISTS OF STANDARD CHARACTERS WITHOUT CLAIM TO ANY PARTICULAR FONT, STYLE, SIZE, OR COLOR.

FOR ADVERTISING AND MARKETING SERVICES, NAMELY, PROMOTING THE GOODS AND SERVICES OF OTHERS; ADVERTISING SERVICES, PUBLIC RELATIONS AND MARKETING SERVICES, NAMELY, PROMOTING AND MARKETING THE GOODS AND SERVICES OF OTHERS THROUGH ALL PUBLIC COMMUNICATION MEANS; ADVERTISING, PROMOTION AND MARKETING SERVICES IN THE NATURE OF E-MAIL BLAST CAMPAIGNS FOR OTHERS; BUSINESS MARKETING SERVICES; BUSINESS TO BUSINESS DIRECT MARKETING SERVICES; COOPERATIVE ADVERTISING AND MARKETING SERVICES BY WAY OF SOLICITATION, CUSTOMER SERVICE AND PROVIDING MARKETING INFORMATION VIA WEB SITES ON A GLOBAL COMPUTER NETWORK; CUSTOM WRITING SERVICES COMPRISING PUBLIC RELATIONS AND MARKETING MATERIALS FOR THE AUDIO, VIDEO AND TECHNOLOGY INDUSTRIES; DIRECT MARKETING SERVICES; MARKETING SERVICES IN THE FIELD OF PLANNED-GIVING FOR NON-PROFIT AND CHARITABLE ORGANIZATIONS; MARKETING SERVICES, NAMELY, CONSUMER MARKETING RESEARCH; MARKETING SERVICES, NAMELY, PROVIDING INFORMATIONAL WEB PAGES DESIGNED TO GENERATE SALES TRAFFIC VIA HYPERLINKS TO OTHER WEB SITES; MARKETING SERVICES, NAMELY, PROVIDING ON-LINE NON-DOWNLOADABLE VIDEOS TO PROMOTE DOCTORS AND MEDICAL PRACTICES; ON-LINE ADVERTISING AND MARKETING SERVICES; PROMOTION AND MARKETING SERVICES AND RELATED CONSULTING; PROMOTIONAL SERVICES, NAMELY, GUERRILLA MARKETING SERVICES; PROVIDING PROMOTIONAL MARKETING SERVICES TO BUSINESSES IN THE BROADBAND AND MEDIA INDUSTRIES; PUBLIC RELATIONS; PUBLIC RELATIONS, ADVERTISING AND MARKETING SERVICES FOR THE TOURISM AND CONVENTION INDUSTRY, NAMELY, ORGANIZING AND HOSTING SITE INSPECTIONS AND FAMILIARIZATION TOURS FOR WHOLESALEERS, TOUR OPERATORS, TRAVEL AGENTS, MEETING AND INCENTIVE TRAVEL PLANNERS AND TRAVEL MEDIA; TESTING, ANALYSIS AND EVALUATION OF THE BROAD KNOWLEDGE, EXPERIENCE AND PROFESSIONAL JUDGMENT OF PUBLIC RELATIONS PROFESSIONALS FOR PURPOSES OF CAREER ENHANCEMENT AND ADVANCEMENT IN THE FIELD OF PUBLIC RELATIONS (U.S. CLS. 100, 101 AND 102).  
FIRST USE 1-1-2009; IN COMMERCE 1-1-2010.

**CLASS 35—(Continued).**

3,941,506. SAVING PROMISE INC., WASHINGTON, DC. SN 77-852,746. PUB. 6-8-2010, FILED 10-20-2009.

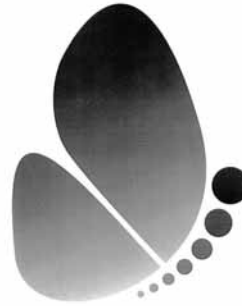

THE STIPPLING IS FOR SHADING PURPOSES. THE MARK CONSISTS OF STYLIZED DESIGN OF BUTTERFLY.

FOR PROMOTING PUBLIC AWARENESS OF THE CAUSES OF AND RESPONSES TO DOMESTIC VIOLENCE (U.S. CLS. 100, 101 AND 102).  
FIRST USE 11-1-2009; IN COMMERCE 11-1-2009.

3,941,522. 9451 BECKER LANE, LLC, TEMPE, AZ. SN 77-858,658. PUB. 9-7-2010, FILED 10-27-2009.



NO CLAIM IS MADE TO THE EXCLUSIVE RIGHT TO USE "MERCHANTS", APART FROM THE MARK AS SHOWN.

THE MARK CONSISTS OF THE WORDS "MERCHANTS GO GREEN" WITH THE IMAGE OF A LEAF. A DOLLAR SIGN APPEARS IN THE LEAF.

FOR GENERAL BUSINESS NETWORKING REFERRAL SERVICES, NAMELY, PROMOTING THE GOODS AND SERVICES OF OTHERS BY PASSING BUSINESS LEADS AND REFERRALS AMONG GROUP MEMBERS (U.S. CLS. 100, 101 AND 102).  
FIRST USE 11-15-2008; IN COMMERCE 11-15-2008.

**CLASS 35—(Continued).**

3,941,527. GREENFEET LLC, CHICO, CA. SN 77-859,647. PUB. 4-13-2010, FILED 10-28-2009.

GREEN WITH A GRIN

THE MARK CONSISTS OF STANDARD CHARACTERS WITHOUT CLAIM TO ANY PARTICULAR FONT, STYLE, SIZE, OR COLOR.

FOR ON-LINE RETAIL STORE SERVICES FEATURING A WIDE VARIETY OF ECO-FRIENDLY CONSUMER GOODS; PROVIDING A WEBSITE FEATURING CONSUMER PRODUCT INFORMATION ON A WIDE VARIETY OF CONSUMER GOODS (U.S. CLS. 100, 101 AND 102).

FIRST USE 9-15-2009; IN COMMERCE 9-15-2009.

3,941,550. AMERICAN INSURANCE ADMINISTRATORS, INC, MECHANICSBURG, PA. SN 77-870,943. PUB. 9-28-2010, FILED 11-12-2009.

DISCOVERHEALTH

THE MARK CONSISTS OF STANDARD CHARACTERS WITHOUT CLAIM TO ANY PARTICULAR FONT, STYLE, SIZE, OR COLOR.

FOR ANALYTICAL REVIEW, ANALYSIS AND EVALUATION OF MEDICAL INSURANCE CLAIMS AND MEDICAL CLAIMS DATA FOR PURCHASERS OF HEALTH INSURANCE FOR PURPOSES OF LOWERING HEALTH INSURANCE RATES; MEDICAL HEALTH PLAN/INSURANCE RATE COST MANAGEMENT, CONTAINMENT AND REDUCTION THROUGH THE APPLICATION OF INFORMATION GLEANED FROM PROPRIETARY, STATE-OF-THE ART DATA MINING AND PREDICTIVE MODELING. COST-MANAGEMENT OF HEALTH BENEFIT PLANS FOR OTHERS (U.S. CLS. 100, 101 AND 102).

FIRST USE 0-0-2010; IN COMMERCE 1-5-2011.

**CLASS 35—(Continued).**

3,941,594. KEANE, INC., BOSTON, MA. SN 77-880,225. PUB. 4-27-2010, FILED 11-24-2009.



THE MARK CONSISTS OF AN ASTERISK IN STYLIZED FORM.

FOR BUSINESS PROGRAM MANAGEMENT SERVICES; BUSINESS PROJECT MANAGEMENT SERVICES; HUMAN RESOURCE CONSULTING SERVICES; BUSINESS MANAGEMENT SERVICES; BUSINESS CONSULTATION SERVICES; BUSINESS PROCESS OUTSOURCING SERVICES IN A WIDE VARIETY OF FIELDS (U.S. CLS. 100, 101 AND 102).

FIRST USE 9-0-2009; IN COMMERCE 9-0-2009.

3,941,615. GEBBIA, JIM, MATTITUCK, NY. SN 77-884,652. PUB. 4-27-2010, FILED 12-2-2009.

WoofWoofStore.com

THE MARK CONSISTS OF STANDARD CHARACTERS WITHOUT CLAIM TO ANY PARTICULAR FONT, STYLE, SIZE, OR COLOR.

FOR ONLINE RETAIL STORE SERVICES IN THE FIELD OF GIFTS AND NOVELTY ITEMS (U.S. CLS. 100, 101 AND 102).

FIRST USE 12-14-2010; IN COMMERCE 12-14-2010.

**CLASS 35—(Continued).**

3,941,627. YOCHA DEHE WINTUN NATION, BROOKS, CA. SN 77-889,890. PUB. 2-16-2010, FILED 12-9-2009.



THE MARK CONSISTS OF A CIRCLE WITH THREE FEATHERS EXTENDING DOWN FROM THE CIRCLE. THE CENTER OF THE CIRCLE CONTAINS AN ANIMAL'S PAW PRINT.

FOR ASSOCIATION SERVICES, NAMELY, PROMOTING THE INTERESTS AND WELFARE OF MEMBERS OF AN INDIAN TRIBE (U.S. CLS. 100, 101 AND 102).

FIRST USE 6-30-2010; IN COMMERCE 6-30-2010.

3,941,628. HAPA HALE INTERNATIONAL, LLC, HONOLULU, HI. SN 77-889,976. PUB. 6-8-2010, FILED 12-9-2009.

**Hapa Hale**

THE MARK CONSISTS OF STANDARD CHARACTERS WITHOUT CLAIM TO ANY PARTICULAR FONT, STYLE, SIZE, OR COLOR.

THE ENGLISH TRANSLATION OF "HAPA" IN THE MARK IS "HALF".

FOR RETAIL STORE SERVICES FEATURING COFFEE, COFFEE DRINKS, COFFEE RELATED ITEMS, AND OTHER FOODS AND BEVERAGES (U.S. CLS. 100, 101 AND 102).

FIRST USE 10-22-2009; IN COMMERCE 5-1-2010.

3,941,636. WINE HOLDINGS, INC., CHICAGO, IL. SN 77-892,841. PUB. 5-11-2010, FILED 12-14-2009.

**BACCHUS AUCTIONEERS**

THE MARK CONSISTS OF STANDARD CHARACTERS WITHOUT CLAIM TO ANY PARTICULAR FONT, STYLE, SIZE, OR COLOR.

**CLASS 35—(Continued).**

NO CLAIM IS MADE TO THE EXCLUSIVE RIGHT TO USE "AUCTIONEERS", APART FROM THE MARK AS SHOWN.

FOR ALCOHOLIC BEVERAGE PROCUREMENT SERVICES FOR OTHERS; ARRANGING OF AUCTION SALES; AUCTIONEERING; AUCTIONEERING OF PROPERTY; CARRYING OUT AUCTION SALES; CONDUCTING OF AUCTION SALES; ON-LINE AUCTION SERVICES; ON-LINE AUCTIONEERING SERVICES VIA THE INTERNET; ON-LINE CONSIGNMENT SERVICES WHEREBY GOODS ARE RECEIVED ON CONSIGNMENT FOR AUCTION ON AN ONLINE AUCTION SITE; ON-LINE CONSIGNMENT SERVICES WHEREBY GOODS ARE RECEIVED ON CONSIGNMENT IN ON-LINE RETAIL STORES FEATURING WINE; ON-LINE RETAIL CONSIGNMENT STORES FEATURING WINE; ORGANISATION OF INTERNET AUCTIONS; PROVIDING ON-LINE AUCTION SERVICES (U.S. CLS. 100, 101 AND 102).

FIRST USE 1-16-2011; IN COMMERCE 1-16-2011.

3,941,655. EILEEN FISHER, INC., NEW YORK, NY. SN 77-895,011. PUB. 6-1-2010, FILED 12-16-2009.

**EILEEN FISHER COMPANY STORE**

THE MARK CONSISTS OF STANDARD CHARACTERS WITHOUT CLAIM TO ANY PARTICULAR FONT, STYLE, SIZE, OR COLOR.

OWNER OF U.S. REG. NOS. 2,624,540, 3,634,309, AND OTHERS.

NO CLAIM IS MADE TO THE EXCLUSIVE RIGHT TO USE "COMPANY STORE", APART FROM THE MARK AS SHOWN.

THE NAME "EILEEN FISHER" IDENTIFIES A LIVING INDIVIDUAL WHOSE CONSENT IS OF RECORD.

FOR RETAIL STORE SERVICES (U.S. CLS. 100, 101 AND 102).

FIRST USE 9-0-2009; IN COMMERCE 9-0-2009.

3,941,673. CRYSTAL ROCK LLC, WATERTOWN, CT. SN 77-897,851. PUB. 6-8-2010, FILED 12-21-2009.



OWNER OF U.S. REG. NOS. 1,839,559 AND 2,812,974. NO CLAIM IS MADE TO THE EXCLUSIVE RIGHT TO USE "BEANS" AND "COFFEE", APART FROM THE MARK AS SHOWN.

**CLASS 35—(Continued).**

THE MARK CONSISTS OF A DEPICTION OF A COFFEE BEAN MARKED WITH THE LETTER "B" ENCIRCLING THE LETTER "C", AND WITH THE WORDS "COOL BEANS COFFEE" APPEARING BELOW THE DEPICTION OF THE COFFEE BEAN.

FOR RETAIL STORE AND MAIL ORDER SERVICES IN THE FIELD OF COFFEE (U.S. CLS. 100, 101 AND 102).  
FIRST USE 4-1-2010; IN COMMERCE 4-1-2010.

---

3,941,677. ARABICA FUNDING, INC., MELVILLE, NY. SN 77-898,304. PUB. 9-21-2010, FILED 12-21-2009.



OWNER OF U.S. REG. NOS. 2,609,319, 3,401,155, AND OTHERS.

NO CLAIM IS MADE TO THE EXCLUSIVE RIGHT TO USE "COFFEE", APART FROM THE MARK AS SHOWN.

THE COLOR(S) BROWN AND TEAL/AQUA IS/ARE CLAIMED AS A FEATURE OF THE MARK.

THE MARK CONSISTS OF THE WORD "CARIBOU" IN STYLIZED LETTERS IN BROWN, FOLLOWED BY THE STYLIZED DESIGN OF A LEAPING CARIBOU IN BROWN AGAINST THE BACKGROUND OF A SHIELD IN TEAL/AQUA, FOLLOWED BY THE WORD "COFFEE" IN TEAL/AQUA. ALL THREE ELEMENTS IN A HORIZONTAL LINE.

FOR RETAIL STORE SERVICES, AND ON-LINE RETAIL STORES SERVICES FEATURING COFFEE, TEA, COFFEE AND TEA BREWING ACCESSORIES, FOOD, AND BEVERAGeware; RETAIL STORE SERVICES IN THE FIELD OF COFFEE, TEA, COFFEE AND TEA BREWING ACCESSORIES, FOOD, AND BEVERAGeware, FEATURING A BONUS INCENTIVE PROGRAM FOR CUSTOMERS (U.S. CLS. 100, 101 AND 102).

FIRST USE 3-1-2010; IN COMMERCE 3-1-2010.

---

3,941,678. ARABICA FUNDING, INC., MELVILLE, NY. SN 77-898,345. PUB. 9-21-2010, FILED 12-21-2009.



OWNER OF U.S. REG. NOS. 2,588,045, 2,703,747, AND 3,162,687.

THE COLOR(S) BROWN AND TEAL/AQUA IS/ARE CLAIMED AS A FEATURE OF THE MARK.

**CLASS 35—(Continued).**

THE MARK CONSISTS OF A STYLIZED DESIGN OF A LEAPING CARIBOU IN BROWN AGAINST THE BACKGROUND OF A SHIELD IN TEAL/AQUA.

FOR RETAIL STORE SERVICES, AND ON-LINE RETAIL STORES SERVICES FEATURING COFFEE, TEA, COFFEE AND TEA BREWING ACCESSORIES, FOOD, AND BEVERAGeware; RETAIL STORE SERVICES IN THE FIELD OF COFFEE, TEA, COFFEE AND TEA BREWING ACCESSORIES, FOOD, AND BEVERAGeware, FEATURING A BONUS INCENTIVE PROGRAM FOR CUSTOMERS (U.S. CLS. 100, 101 AND 102).

FIRST USE 3-1-2010; IN COMMERCE 3-1-2010.

---

3,941,692. NOLL, MARK, COCONUT CREEK, FL. SN 77-899,938. PUB. 5-18-2010, FILED 12-23-2009.

## It's Owl Time

THE MARK CONSISTS OF STANDARD CHARACTERS WITHOUT CLAIM TO ANY PARTICULAR FONT, STYLE, SIZE, OR COLOR.

FOR RETAIL STORE FEATURING COLLEGIATE SPORTS MERCHANDISE (U.S. CLS. 100, 101 AND 102).

FIRST USE 1-3-2011; IN COMMERCE 1-3-2011.

---

3,941,717. WARRICK, MERCEDES, LAS VEGAS, NV. SN 77-904,455. PUB. 5-18-2010, FILED 1-4-2010.

## The Soul Inspired Business Network

THE MARK CONSISTS OF STANDARD CHARACTERS WITHOUT CLAIM TO ANY PARTICULAR FONT, STYLE, SIZE, OR COLOR.

NO CLAIM IS MADE TO THE EXCLUSIVE RIGHT TO USE "BUSINESS NETWORK", APART FROM THE MARK AS SHOWN.

FOR BUSINESS NETWORKING; ON-LINE BUSINESS NETWORKING SERVICES (U.S. CLS. 100, 101 AND 102).

FIRST USE 6-15-2010; IN COMMERCE 6-15-2010.

**CLASS 35—(Continued).**

3,941,723. RME, LLC, TAMPA, FL. SN 77-905,974. PUB. 5-25-2010, FILED 1-6-2010.

## TALKING MAIL

THE MARK CONSISTS OF STANDARD CHARACTERS WITHOUT CLAIM TO ANY PARTICULAR FONT, STYLE, SIZE, OR COLOR.

NO CLAIM IS MADE TO THE EXCLUSIVE RIGHT TO USE "MAIL", APART FROM THE MARK AS SHOWN.

FOR DIRECT MAIL ADVERTISING SERVICES; DIRECT MAIL ADVERTISING SERVICES FEATURING DIRECT MAIL THAT PROMPTS THE CONSUMER TO VISIT A PERSONALIZED WEBPAGE THAT CONTAINS ADVERTISING CONTENT TAILORED TO THE CONSUMER THAT RECEIVED THE DIRECT MAIL ITEM (U.S. CLS. 100, 101 AND 102).

FIRST USE 8-0-2007; IN COMMERCE 8-7-2007.

3,941,725. WASTE MANAGEMENT, INC., HOUSTON, TX. SN 77-906,484. PUB. 5-25-2010, FILED 1-6-2010.

## GREENOPOLIS REWARDS

THE MARK CONSISTS OF STANDARD CHARACTERS WITHOUT CLAIM TO ANY PARTICULAR FONT, STYLE, SIZE, OR COLOR.

OWNER OF U.S. REG. NO. 3,677,065.

NO CLAIM IS MADE TO THE EXCLUSIVE RIGHT TO USE "REWARDS", APART FROM THE MARK AS SHOWN.

FOR PROMOTING PUBLIC AWARENESS OF ENVIRONMENTAL ISSUES BY ARRANGING AND CONDUCTING AN INCENTIVE AWARD PROGRAM WHICH PROMOTES POSITIVE ENVIRONMENTAL ACTIVITIES SUCH AS RECYCLING, BUYING AND USING PRODUCTS FOR RECYCLING, BUYING AND USING RECYCLED PRODUCTS, AND BUYING AND USING PRODUCTS MADE WITH RECYCLED MATERIALS (U.S. CLS. 100, 101 AND 102).

FIRST USE 1-19-2011; IN COMMERCE 1-19-2011.

3,941,746. DEMALDERIS, JOSEPH, DBA CROSS CURRENT GUIDE SERVICE, MILFORD, PA. SN 77-910,485. PUB. 6-1-2010, FILED 1-12-2010.

## Double Haul Club

THE MARK CONSISTS OF STANDARD CHARACTERS WITHOUT CLAIM TO ANY PARTICULAR FONT, STYLE, SIZE, OR COLOR.

**CLASS 35—(Continued).**

NO CLAIM IS MADE TO THE EXCLUSIVE RIGHT TO USE "CLUB", APART FROM THE MARK AS SHOWN.

FOR CUSTOMER LOYALTY SERVICES AND CUSTOMER CLUB SERVICES, FOR COMMERCIAL, PROMOTIONAL AND/OR ADVERTISING PURPOSES (U.S. CLS. 100, 101 AND 102).

FIRST USE 12-7-2010; IN COMMERCE 12-7-2010.

3,941,753. ABILENE CHAMBER OF COMMERCE, DBA ABILENE CONVENTION AND VISTOR'S BUREAU, ABILENE, TX. SN 77-911,416. PUB. 5-25-2010, FILED 1-13-2010.

## Whole Lotta Texas Goin' On

THE MARK CONSISTS OF STANDARD CHARACTERS WITHOUT CLAIM TO ANY PARTICULAR FONT, STYLE, SIZE, OR COLOR.

NO CLAIM IS MADE TO THE EXCLUSIVE RIGHT TO USE "TEXAS", APART FROM THE MARK AS SHOWN.

FOR CHAMBER OF COMMERCE SERVICES, NAMELY, LOCAL, REGIONAL AND NATIONAL MARKETING AND PROMOTION OF BUSINESS AND TOURISM IN ABILENE, TEXAS (U.S. CLS. 100, 101 AND 102).

FIRST USE 9-2-2010; IN COMMERCE 9-2-2010.

3,941,797. LLJ USA, LLC, DBA WWW.LLJUSA.COM, DORR, MI. SN 77-918,868. PUB. 6-8-2010, FILED 1-24-2010.



NO CLAIM IS MADE TO THE EXCLUSIVE RIGHT TO USE "USA AMERICAN MADE GOODS & GIFTS", APART FROM THE MARK AS SHOWN.

THE COLOR(S) RED, WHITE, BLUE, TAUPE, GREY IS/ ARE CLAIMED AS A FEATURE OF THE MARK.

THE MARK CONSISTS OF THE FOLLOWING: CASCADING GREY STARS OVER WORDING "LLJ USA" IN BLUE, WITH A WHITE STAR IN THE CENTER OF THE LETTER "A", AND AN IMAGE OF A GIFT BOX WRAPPED WITH AN AMERICAN FLAG WITH RED AND WHITE STRIPES AND A BLUE FIELD WITH WHITE STARS AND A GREY BOW ON TOP. BELOW ARE THE WORDING "AMERICAN MADE GOODS &" IN BLUE AND THE WORDING "GIFTS" IN RED.

FOR ONLINE RETAIL STORE SERVICES FEATURING A WIDE VARIETY OF CONSUMER GOODS THAT ARE MADE IN PART OR IN WHOLE IN THE USA (U.S. CLS. 100, 101 AND 102).

FIRST USE 2-15-2010; IN COMMERCE 1-31-2011.

**CLASS 35—(Continued).**

3,941,812. ALWAYS BUYING SCRAP, INC., DURHAM, NC. SN 77-920,210. PUB. 6-8-2010, FILED 1-26-2010.

**ALWAYS BUYING SCRAP**

THE MARK CONSISTS OF STANDARD CHARACTERS WITHOUT CLAIM TO ANY PARTICULAR FONT, STYLE, SIZE, OR COLOR.

NO CLAIM IS MADE TO THE EXCLUSIVE RIGHT TO USE "BUYING SCRAP", APART FROM THE MARK AS SHOWN.

FOR SCRAP DEALERSHIPS (U.S. CLS. 100, 101 AND 102).

FIRST USE 1-7-2010; IN COMMERCE 1-7-2010.

**CLASS 35—(Continued).**

3,941,821. THE ALCHEMY SOLUTIONS GROUP, INC., POWDER SPRINGS, GA. SN 77-921,019. PUB. 8-17-2010, FILED 1-27-2010.

**BVA**

THE MARK CONSISTS OF STANDARD CHARACTERS WITHOUT CLAIM TO ANY PARTICULAR FONT, STYLE, SIZE, OR COLOR.

FOR BUSINESS SERVICES, NAMELY, CONSUMER RESEARCH AND CONSULTING RELATED THERETO (U.S. CLS. 100, 101 AND 102).

FIRST USE 1-0-2008; IN COMMERCE 1-0-2008.

3,941,814. VOLLARA CONCEPTS, LLC, DALLAS, TX. SN 77-920,226. PUB. 6-15-2010, FILED 1-26-2010.

**WITH VOLLARA SUCCESS IS  
NOT AN ACCIDENT; IT'S ALL  
WE KNOW**

THE MARK CONSISTS OF STANDARD CHARACTERS WITHOUT CLAIM TO ANY PARTICULAR FONT, STYLE, SIZE, OR COLOR.

FOR MULTI-LEVEL MARKETING BUSINESS SERVICES; PROMOTION OF BUSINESS OPPORTUNITIES (U.S. CLS. 100, 101 AND 102).

FIRST USE 2-1-2010; IN COMMERCE 2-1-2010.

3,941,825. HOUR MEDIA, L.L.C., ROYAL OAK, MI. SN 77-921,234. PUB. 6-15-2010, FILED 1-27-2010.

**RESUMESGALORE.COM**

THE MARK CONSISTS OF STANDARD CHARACTERS WITHOUT CLAIM TO ANY PARTICULAR FONT, STYLE, SIZE, OR COLOR.

FOR ONLINE INFORMATION IN THE FIELDS OF EMPLOYMENT AND CAREERS; ONLINE EMPLOYMENT, RECRUITMENT, AND JOB SEARCH INFORMATION SERVICES (U.S. CLS. 100, 101 AND 102).

FIRST USE 6-1-2010; IN COMMERCE 6-1-2010.

3,941,815. VOLLARA CONCEPTS, LLC, DALLAS, TX. SN 77-920,235. PUB. 6-15-2010, FILED 1-26-2010.

**REWARDS FOR EVERY STEP YOU  
TAKE**

THE MARK CONSISTS OF STANDARD CHARACTERS WITHOUT CLAIM TO ANY PARTICULAR FONT, STYLE, SIZE, OR COLOR.

FOR MULTI-LEVEL MARKETING BUSINESS SERVICES; PROMOTION OF BUSINESS OPPORTUNITIES (U.S. CLS. 100, 101 AND 102).

FIRST USE 2-1-2010; IN COMMERCE 2-1-2010.

3,941,852. SOOVOX INC., SAN DIEGO, CA. SN 77-926,365. PUB. 6-22-2010, FILED 2-2-2010.

**Social IQ**

THE MARK CONSISTS OF STANDARD CHARACTERS WITHOUT CLAIM TO ANY PARTICULAR FONT, STYLE, SIZE, OR COLOR.

FOR ADVERTISING SERVICES; MARKET RESEARCH (U.S. CLS. 100, 101 AND 102).

FIRST USE 8-1-2009; IN COMMERCE 8-1-2009.



**CLASS 35—(Continued).**

3,941,866. PROVELL, INC., MINNEAPOLIS, MN. SN 77-929,076. PUB. 10-5-2010, FILED 2-5-2010.

**TASTE FOR SAVINGS**

THE MARK CONSISTS OF STANDARD CHARACTERS WITHOUT CLAIM TO ANY PARTICULAR FONT, STYLE, SIZE, OR COLOR.

NO CLAIM IS MADE TO THE EXCLUSIVE RIGHT TO USE "SAVINGS", APART FROM THE MARK AS SHOWN.

FOR BUYING CLUB SERVICES; ONLINE, PHONE AND MAIL ORDER SERVICES FOR GOODS INCLUDING THE PROVISION OF GROCERY AND HOUSEHOLD GOODS DISCOUNTS AND SAVINGS COUPONS AND CERTIFICATES, ALL FEATURING GENERAL CONSUMER MERCHANDISE AND; PROMOTING THE SALE OF THE GOODS AND SERVICES OF OTHERS THROUGH THE DISTRIBUTION OF COUPONS AND DISCOUNT OFFERS BY MEANS OF DISCOUNT COUPONS, AND VIA ON-LINE DISCOUNT COUPON CODES; PROMOTING THE SALE OF THE GOODS AND SERVICES OF OTHERS THROUGH THE DISTRIBUTION OF GIFT CARDS AND STORED VALUE GIFT CARDS, WHEREIN THE ELIGIBILITY FOR THE DISTRIBUTION OF THESE CARDS IS PURCHASE ACTIVATED; PROMOTING THE SALE OF THE GOODS AND SERVICES OF OTHERS BY PROVIDING PURCHASE ACTIVATED DISCOUNT BENEFITS, NAMELY, REBATES, GIFTS, GIVE-AWAYS, DISCOUNTED PURCHASES, SHIPPING AND HANDLING CHARGE WAIVERS, AND REFUNDS TO THE PURCHASER'S ACCOUNT AT THIRD PARTY PAYMENT PROCESSORS (U.S. CLS. 100, 101 AND 102).

FIRST USE 6-1-2010; IN COMMERCE 6-1-2010.

3,941,869. CLARENDON CAPITAL CORPORATION, ATLANTA, GA. SN 77-929,222. PUB. 6-22-2010, FILED 2-5-2010.

**The Clear Choice in  
Outdoor Advertising**

THE MARK CONSISTS OF STANDARD CHARACTERS WITHOUT CLAIM TO ANY PARTICULAR FONT, STYLE, SIZE, OR COLOR.

FOR ADVERTISING AND ADVERTISEMENT SERVICES; ADVERTISING AND MARKETING SERVICES, NAMELY, PROMOTING THE GOODS AND SERVICES OF OTHERS; ELECTRONIC BILLBOARD ADVERTISING; OUT-OF-HOME ADVERTISING SERVICES, NAMELY, RENTAL OF ADVERTISING SPACE, AND PREPARING AND PLACING ADVERTISEMENTS FOR OTHERS; PREPARING AND PLACING OUTDOOR ADVERTISEMENTS FOR OTHERS; PROVIDING ADVERTISING SPACE ON BILLBOARDS AND IN KIOSKS; RENTAL OF ADVERTISING SPACE; RENTAL OF SIGNS FOR ADVERTISING PURPOSES (U.S. CLS. 100, 101 AND 102).

FIRST USE 6-1-2009; IN COMMERCE 6-1-2009.

**CLASS 35—(Continued).**

3,941,885. BOWMAN, ERIK, REDONDO BEACH, CA. SN 77-931,543. PUB. 6-29-2010, FILED 2-9-2010.

**Entrepreneur Boot Camp**

THE MARK CONSISTS OF STANDARD CHARACTERS WITHOUT CLAIM TO ANY PARTICULAR FONT, STYLE, SIZE, OR COLOR.

NO CLAIM IS MADE TO THE EXCLUSIVE RIGHT TO USE "ENTREPRENEUR", APART FROM THE MARK AS SHOWN.

FOR CONSULTING IN THE FIELD OF BUSINESS, MANAGEMENT AND ENTREPRENEURSHIP THROUGH WEB BASED TOOLS AND IN PERSON GROUP ENVIRONMENTS (U.S. CLS. 100, 101 AND 102).

FIRST USE 2-9-2010; IN COMMERCE 6-15-2010.

3,941,891. KAASI ASSOCIATE LLC, HOLBROOK, NY. SN 77-932,985. PUB. 6-22-2010, FILED 2-10-2010.

**Kaasi Associate**

THE MARK CONSISTS OF STANDARD CHARACTERS WITHOUT CLAIM TO ANY PARTICULAR FONT, STYLE, SIZE, OR COLOR.

NO CLAIM IS MADE TO THE EXCLUSIVE RIGHT TO USE "ASSOCIATE", APART FROM THE MARK AS SHOWN.

THE WORDING "KAASI" HAS NO MEANING IN A FOREIGN LANGUAGE.

FOR FRANCHISING, NAMELY, CONSULTATION AND ASSISTANCE IN BUSINESS MANAGEMENT, ORGANIZATION AND PROMOTION; RESTAURANT FRANCHISING, NAMELY, OFFERING BUSINESS MANAGEMENT ASSISTANCE IN THE ESTABLISHMENT AND/OR OPERATION OF RESTAURANTS; FRANCHISING, NAMELY, OFFERING BUSINESS MANAGEMENT ASSISTANCE IN THE ESTABLISHMENT AND/OR OPERATION OF RESTAURANTS AND FOOD RELATED BUSINESS MANAGEMENT (U.S. CLS. 100, 101 AND 102).

FIRST USE 11-5-2010; IN COMMERCE 11-5-2010.

3,941,901. DOLLAR TREE STORES, INC., CHESAPEAKE, VA. SN 77-935,926. PUB. 6-8-2010, FILED 2-15-2010.

**FUN, FRESH, FRUGAL.**

THE MARK CONSISTS OF STANDARD CHARACTERS WITHOUT CLAIM TO ANY PARTICULAR FONT, STYLE, SIZE, OR COLOR.

NO CLAIM IS MADE TO THE EXCLUSIVE RIGHT TO USE "FRESH", APART FROM THE MARK AS SHOWN.

FOR RETAIL DISCOUNT STORE SERVICES IN THE FIELD OF GENERAL MERCHANDISE AND FOOD (U.S. CLS. 100, 101 AND 102).

FIRST USE 3-0-2010; IN COMMERCE 3-21-2010.

**CLASS 35—(Continued).**

3,941,903. HEADHUNTER SYSTEMS, LTD., LONDON, UNITED KINGDOM. SN 77-936,151. PUB. 7-6-2010, FILED 2-16-2010.

## See-V

THE MARK CONSISTS OF STANDARD CHARACTERS WITHOUT CLAIM TO ANY PARTICULAR FONT, STYLE, SIZE, OR COLOR.

FOR PROVIDING AN ON-LINE SEARCHABLE DATABASE FEATURING EMPLOYMENT OPPORTUNITIES AND JOB SEEKERS; PROVIDING A WEB SITE WITH VIDEO APPLICATIONS TO SUPPORT RECRUITING AND GENERAL CANDIDATE SCREENING PROCESSES (U.S. CLS. 100, 101 AND 102).

FIRST USE 0-0-2010; IN COMMERCE 0-0-2010.

3,941,925. PATERNITY PAINS LLC, NEW YORK, NY. SN 77-943,533. PUB. 7-20-2010, FILED 2-24-2010.

## Paternity Pains

THE MARK CONSISTS OF STANDARD CHARACTERS WITHOUT CLAIM TO ANY PARTICULAR FONT, STYLE, SIZE, OR COLOR.

FOR COMPUTERIZED ON-LINE RETAIL STORE IN THE FIELD OF CLOTHING, HEADGEAR, TOYS, GAMES, PLAYTHINGS, ALL FOR BABIES, INFANTS, CHILDREN, FATHERS-TO-BE AND MOTHERS-TO-BE (U.S. CLS. 100, 101 AND 102).

FIRST USE 7-12-2010; IN COMMERCE 7-12-2010.

**CLASS 35—(Continued).**

3,941,927. WINKS LANE, INC., WILMINGTON, DE. SN 77-944,544. PUB. 8-10-2010, FILED 2-25-2010.

## SONSILIVING

THE MARK CONSISTS OF STANDARD CHARACTERS WITHOUT CLAIM TO ANY PARTICULAR FONT, STYLE, SIZE, OR COLOR.

FOR ON-LINE RETAIL STORE SERVICES FEATURING WOMEN'S WEARING APPAREL AND ACCESSORIES; INTERNET ADVERTISING SERVICES PROVIDED VIA WEBSITES, WEB BASED SOCIAL MEDIA, SOCIAL CONVERSATIONS OVER THE INTERNET, EMAILS, MICROBLOGS, BLOGS, GROUP FORUMS, ELECTRONIC MESSAGES, INSTANT MESSAGES, TEXT MESSAGES, MULTIMEDIA MESSAGES, SOCIAL NETWORKS, STATUS UPDATES, FORUMS, ELECTRONIC BULLETIN BOARDS (U.S. CLS. 100, 101 AND 102).

FIRST USE 6-1-2010; IN COMMERCE 6-1-2010.

3,941,966. ROBBIE MANUFACTURING, INC., LENEXA, KS. SN 77-957,536. PUB. 8-24-2010, FILED 3-12-2010.

## JOE'S ROOM - JUST ONE EARTH

THE MARK CONSISTS OF STANDARD CHARACTERS WITHOUT CLAIM TO ANY PARTICULAR FONT, STYLE, SIZE, OR COLOR.

FOR PROMOTING PUBLIC INTEREST IN AND AWARENESS OF SUSTAINABILITY PROJECT INITIATIVES AND EDUCATION, INCLUDING PROMOTING ENVIRONMENTAL, ECOLOGICAL AND SUSTAINABILITY ISSUES, AND THE SOCIETAL, ECOLOGICAL AND ECONOMIC BENEFITS DERIVED FROM ENVIRONMENTAL SUSTAINABILITY POLICIES AND PRACTICES, ESPECIALLY DIRECTED TO THE PRODUCT PACKAGING AND PRINTING INDUSTRIES; PROMOTING SUSTAINABLE GREEN BUSINESS SOLUTIONS AND PRACTICES, AND THE SOCIETAL, ECOLOGICAL AND ECONOMIC BENEFITS DERIVED FROM SUSTAINABLE GREEN BUSINESS SOLUTIONS AND PRACTICES, ESPECIALLY DIRECTED TOWARD THE PRODUCT PACKAGING AND PRINT INDUSTRIES; PROVIDING A WEB SITE FEATURING INFORMATION ABOUT SUSTAINABILITY PROJECT INITIATIVES, NAMELY, ENVIRONMENTAL, ECOLOGICAL AND SUSTAINABILITY ISSUES, AND THE SOCIETAL, ECOLOGICAL AND ECONOMIC BENEFITS DERIVED FROM ENVIRONMENTAL SUSTAINABILITY POLICIES AND PRACTICES, PROVIDED TO ASSIST CUSTOMERS TO BUY MORE ENVIRONMENTALLY FRIENDLY PRODUCTS, ESPECIALLY DIRECTED TOWARD THE PRODUCT PACKAGING AND PRINTING INDUSTRIES (U.S. CLS. 100, 101 AND 102).

FIRST USE 12-27-2010; IN COMMERCE 12-27-2010.

**CLASS 35—(Continued).**

3,942,016. NEXTERA ENERGY, INC., JUNO BEACH, FL. SN 77-981,184. PUB. 9-22-2009, FILED 4-14-2009.

# NEXTERA

THE MARK CONSISTS OF STANDARD CHARACTERS WITHOUT CLAIM TO ANY PARTICULAR FONT, STYLE, SIZE, OR COLOR.

OWNER OF U.S. REG. NO. 3,620,150.  
FOR BUSINESS SERVICES, NAMELY, BUSINESS OPERATION AND BUSINESS MANAGEMENT SUPERVISION OF SOLAR POWER GENERATION FACILITIES FOR OTHERS; BUSINESS MANAGEMENT SERVICES, NAMELY, FACILITIES MANAGEMENT OF TECHNICAL OPERATIONS OF SOLAR ENERGY FACILITIES FOR OTHERS (U.S. CLS. 100, 101 AND 102).  
FIRST USE 1-7-2009; IN COMMERCE 1-7-2009.

3,942,020. IM READY-MADE LLC, NEW YORK, NY. SN 77-981,234. PUB. 11-3-2009, FILED 6-16-2009.

# Isaac Mizrahi

THE MARK CONSISTS OF STANDARD CHARACTERS WITHOUT CLAIM TO ANY PARTICULAR FONT, STYLE, SIZE, OR COLOR.

OWNER OF U.S. REG. NOS. 1,524,672, 3,293,901, AND OTHERS.

THE NAME(S), PORTRAIT(S), AND/OR SIGNATURE(S) SHOWN IN THE MARK IDENTIFIES "ISAAC MIZRAHI", WHOSE CONSENT(S) TO REGISTER IS MADE OF RECORD.

FOR RETAIL STORE AND ON-LINE RETAIL STORE SERVICES FEATURING APPAREL, ACCESSORIES, FRAGRANCES AND COSMETICS (U.S. CLS. 100, 101 AND 102).

FIRST USE 8-0-2010; IN COMMERCE 8-0-2010.

3,942,025. MATTSO, BRIAN M., CHICAGO, IL. SN 77-981,268. PUB. 11-11-2008, FILED 6-19-2008.

# THE RIGHT MIX

THE MARK CONSISTS OF STANDARD CHARACTERS WITHOUT CLAIM TO ANY PARTICULAR FONT, STYLE, SIZE, OR COLOR.

FOR RETAIL STORE SERVICES FEATURING A WIDE VARIETY OF CONSUMER GOODS OF OTHERS (U.S. CLS. 100, 101 AND 102).

FIRST USE 1-10-2011; IN COMMERCE 1-10-2011.

**CLASS 35—(Continued).**

3,942,045. JACK ROGERS HOLDING COMPANY LLC, NEW YORK, NY. SN 77-981,449. PUB. 7-6-2010, FILED 11-24-2009.

# HELLO JACK

THE MARK CONSISTS OF STANDARD CHARACTERS WITHOUT CLAIM TO ANY PARTICULAR FONT, STYLE, SIZE, OR COLOR.

FOR RETAIL STORE AND ONLINE RETAIL STORE SERVICES IN THE FIELDS OF CLOTHING, FOOTWEAR, AND ACCESSORIES (U.S. CLS. 100, 101 AND 102).

FIRST USE 11-24-2009; IN COMMERCE 11-24-2009.

3,942,051. FITNESS QUEST, INC., CANTON, OH. SN 78-579,488. PUB. 4-21-2009, FILED 3-3-2005.

# VALUE QUEST

THE MARK CONSISTS OF STANDARD CHARACTERS WITHOUT CLAIM TO ANY PARTICULAR FONT, STYLE, SIZE, OR COLOR.

FOR DISTRIBUTORSHIPS IN THE FIELD OF MERCHANDISE FOR HOME USE, NAMELY, APPLIANCES, HOME IMPROVEMENT, PATIO AND GARDEN/OUTDOOR, GIFT ITEMS, HOUSEHOLD ITEMS IN THE NATURE OF FLOOR MOPS, CLEANING CLOTHS, CLEANING SUPPLIES, FURNITURE, AND HOUSEHOLD TOOLS, HEALTH AND SAFETY AND PERSONAL USE MERCHANDISE, NAMELY, BED, HAIR AND GROOMING, COSMETICS AND CLOTHING ITEMS; DISTRIBUTORSHIPS IN THE FIELD OF ARTS AND CRAFTS (U.S. CLS. 100, 101 AND 102).

FIRST USE 12-31-2009; IN COMMERCE 12-31-2009.

3,942,061. PLENUS, SOCIEDAD ANONIMA DE CAPITAL VARIABLE, SAN PEDRO GARZA GARCIA, MEXICO. SN 78-835,176. PUB. 11-20-2007, FILED 3-12-2006.

# PLENUS.

PRIORITY CLAIMED UNDER SEC. 44(D) ON MEXICO APPLICATION NO. 751040, FILED 11-16-2005, REG. NO. 918106, DATED 11-16-2005, EXPIRES 11-16-2015.

THE STIPPLING IS FOR SHADING PURPOSES ONLY.  
FOR BUSINESS MARKETING SERVICES; BUSINESS MARKETING SERVICES IN THE FIELD OF REAL ESTATE, FINANCIAL SERVICES, TECHNOLOGY, AND BIOTECHNOLOGY; BUSINESS MANAGEMENT (U.S. CLS. 100, 101 AND 102).

FIRST USE 0-0-2009; IN COMMERCE 0-0-2009.

**CLASS 35—(Continued).**

3,942,062. Q PHARMACY, INC., SAN ANTONIO, TX. SN 78-844,539. PUB. 11-21-2006, FILED 3-23-2006.

**FREEDOM TO LIVE**

THE MARK CONSISTS OF STANDARD CHARACTERS WITHOUT CLAIM TO ANY PARTICULAR FONT, STYLE, SIZE, OR COLOR.

FOR RETAIL STORE SERVICES, NAMELY, PHARMACY, RETAIL DRUG STORE AND GENERAL MERCHANDISE STORE SERVICES (U.S. CLS. 100, 101 AND 102).

FIRST USE 6-0-2006; IN COMMERCE 6-0-2006.

---

3,942,068. CHEFWEAR, INC., ADDISON, IL. SN 78-926,766. PUB. 3-13-2007, FILED 7-11-2006.

**THE ORIGINAL CHEFWEAR**

THE MARK CONSISTS OF STANDARD CHARACTERS WITHOUT CLAIM TO ANY PARTICULAR FONT, STYLE, SIZE, OR COLOR.

OWNER OF U.S. REG. NOS. 2,187,263, 2,897,130, AND OTHERS.

NO CLAIM IS MADE TO THE EXCLUSIVE RIGHT TO USE "ORIGINAL", APART FROM THE MARK AS SHOWN. SEC. 2(F) AS TO "CHEFWEAR".

FOR MAIL-ORDER CATALOG SERVICES FEATURING CLOTHING FOR RESTAURANT AND FOOD-SERVICE STAFF (U.S. CLS. 100, 101 AND 102).

FIRST USE 4-1-2000; IN COMMERCE 4-1-2000.

---

3,942,071. HEALTHTRAN, LLC, GREENWOOD VILLAGE, CO. SN 78-940,965. PUB. 10-16-2007, FILED 7-31-2006.

**SCRIPTREWARDS**

THE MARK CONSISTS OF STANDARD CHARACTERS WITHOUT CLAIM TO ANY PARTICULAR FONT, STYLE, SIZE, OR COLOR.

FOR CUSTOMER INCENTIVE PROGRAMS TO PROMOTE CUSTOMER LOYALTY AND THE SALE OF PRODUCTS AND SERVICES OF OTHERS, WHICH PROVIDE MEMBERS AND CUSTOMERS WITH BENEFITS FOR COST SAVING CHOICES ON PRESCRIPTION PRODUCTS (U.S. CLS. 100, 101 AND 102).

FIRST USE 7-12-2010; IN COMMERCE 7-12-2010.

**CLASS 35—(Continued).**

3,942,115. BOHNING COMPANY, LTD., THE LAKE CITY, MI. SN 85-017,865. PUB. 11-9-2010, FILED 4-20-2010.



OWNER OF U.S. REG. NOS. 3,774,608, 3,813,275, AND OTHERS.

THE MARK CONSISTS OF AN ARROW DESIGN DEPICTING AN ARROW END INCLUDING THE FLETCHING, NOCK AND A SHORT SECTION OF AN ARROW SHAFT WITH AN ABSTRACT ARROW HEAD AT THE END OF THE SHORT SECTION OF THE ARROW SHAFT, THE WORD "BOHNING" BEING POSITIONED TO THE RIGHT OF THE ARROW DESIGN AND THE ARROW DESIGN AND THE WORD "BOHNING" BEING ENCLOSED IN A RECTANGULAR BOX.

FOR CATALOG ORDERING SERVICE FEATURING ARCHERY EQUIPMENT, NAMELY, QUIVERS, VANES, NOCKS, ADHESIVES, FLETCHING JIGS, STRINGS, ACCESSORIES, ARROW WRAPS, LACQUERS AND PAINTS FOR ARROWS, WAX, BOWFISHING EQUIPMENT AND SPORTING BODY WEAR; MAIL ORDER CATALOG SERVICES FEATURING ARCHERY EQUIPMENT, NAMELY, QUIVERS, VANES, NOCKS, ADHESIVES, FLETCHING JIGS, STRINGS, ACCESSORIES, ARROW WRAPS, LACQUERS AND PAINTS FOR ARROWS, WAX, BOWFISHING EQUIPMENT AND SPORTING BODY WEAR; ON-LINE RETAIL STORE SERVICES FEATURING ARCHERY EQUIPMENT, NAMELY, QUIVERS, VANES, NOCKS, ADHESIVES, FLETCHING JIGS, STRINGS, ACCESSORIES, ARROW WRAPS, LACQUERS AND PAINTS FOR ARROWS, WAX, BOWFISHING EQUIPMENT AND SPORTING BODY WEAR (U.S. CLS. 100, 101 AND 102).

FIRST USE 1-1-2011; IN COMMERCE 1-1-2011.

---

3,942,137. GAP (APPAREL), LLC, SAN FRANCISCO, CA. SN 85-027,730. PUB. 8-24-2010, FILED 4-30-2010.

**PIPERLIME**

THE MARK CONSISTS OF STANDARD CHARACTERS WITHOUT CLAIM TO ANY PARTICULAR FONT, STYLE, SIZE, OR COLOR.

OWNER OF U.S. REG. NOS. 3,469,636, 3,765,525, AND OTHERS.

FOR RETAIL STORE SERVICES FEATURING A WIDE VARIETY OF CONSUMER GOODS OF OTHERS (U.S. CLS. 100, 101 AND 102).

FIRST USE 8-16-2009; IN COMMERCE 8-16-2009.

**CLASS 35—(Continued).**

3,942,140. WILLIAMS, JOHN ALAN, DBA WILLIAMS, JOHN ALAN, SANTA FE, NM. SN 85-028,850. PUB. 10-5-2010, FILED 5-3-2010.

# JArtWorks

THE MARK CONSISTS OF STANDARD CHARACTERS WITHOUT CLAIM TO ANY PARTICULAR FONT, STYLE, SIZE, OR COLOR.

FOR ON-LINE ART GALLERIES (U.S. CLS. 100, 101 AND 102).

FIRST USE 1-1-2009; IN COMMERCE 1-1-2010.

---

3,942,155. STEINHAFELS, INC., WAUKESHA, WI. SN 85-038,083. PUB. 10-12-2010, FILED 5-13-2010.

YOU HUNT. YOU SAVE. YOU  
WIN.

THE MARK CONSISTS OF STANDARD CHARACTERS WITHOUT CLAIM TO ANY PARTICULAR FONT, STYLE, SIZE, OR COLOR.

FOR RETAIL FURNITURE STORES (U.S. CLS. 100, 101 AND 102).

FIRST USE 6-20-2010; IN COMMERCE 6-20-2010.

---

3,942,195. HOUSING 1 SOURCE, LLC, SAN ANTONIO, TX. SN 85-049,436. PUB. 10-26-2010, FILED 5-27-2010.

# HOUSING 1 SOURCE

THE MARK CONSISTS OF STANDARD CHARACTERS WITHOUT CLAIM TO ANY PARTICULAR FONT, STYLE, SIZE, OR COLOR.

NO CLAIM IS MADE TO THE EXCLUSIVE RIGHT TO USE "HOUSING", APART FROM THE MARK AS SHOWN.

FOR MOVING AND RELOCATION SERVICES, NAMELY, PLANNING AND PROJECT OVERSIGHT OF HOME MOVING FOR OTHERS; REFERRALS IN THE FIELD OF MOVING AND RELOCATION OF HOMES (U.S. CLS. 100, 101 AND 102).

FIRST USE 10-1-2010; IN COMMERCE 11-1-2010.

**CLASS 35—(Continued).**

3,942,207. ACORN INTERNATIONAL GROUP, INC, SUWANEE, GA. SN 85-051,642. PUB. 11-2-2010, FILED 6-1-2010.

# BOATER'S CONVENIENCE & BEYOND

THE MARK CONSISTS OF STANDARD CHARACTERS WITHOUT CLAIM TO ANY PARTICULAR FONT, STYLE, SIZE, OR COLOR.

NO CLAIM IS MADE TO THE EXCLUSIVE RIGHT TO USE "BOATER'S CONVENIENCE", APART FROM THE MARK AS SHOWN.

FOR DISTRIBUTORSHIP SERVICES FEATURING MARINE AND BOATING SUPPLIES AND ACCESSORIES (U.S. CLS. 100, 101 AND 102).

FIRST USE 1-1-2011; IN COMMERCE 1-1-2011.

---

3,942,218. VESCE, ERNEST D., MT. KISCO, NY. SN 85-053,899. PUB. 11-16-2010, FILED 6-3-2010.



NO CLAIM IS MADE TO THE EXCLUSIVE RIGHT TO USE "STORE" AND "SELL", APART FROM THE MARK AS SHOWN.

THE COLOR(S) RED, WHITE, BLUE, BLACK AND YELLOW IS/ARE CLAIMED AS A FEATURE OF THE MARK.

THE MARK CONSISTS OF THREE CONCENTRIC RECTANGLES OF DIFFERENT SIZES OVERLAPPING EACH OTHER, WITH THE LARGEST RECTANGLE IN THE BACK DISPLAYED IN COLOR RED, A SMALLER RECTANGLE IN THE MIDDLE DISPLAYED IN WHITE, AND THE SMALLEST RECTANGLE IN THE FRONT DISPLAYED IN BLUE. THE BORDERS OF THE TRIANGLES ARE DISPLAYED IN BLACK. INSIDE THE FRONT TRIANGLE, THE LITERAL ELEMENT "STORE & SELL" APPEARS, DISPLAYED IN GOLD YELLOW COLOR.

FOR RETAIL CONSIGNMENT STORE SERVICES FEATURING A WIDE VARIETY OF NEW AND USED MERCHANDISE AND CONSUMER GOODS OF OTHERS (U.S. CLS. 100, 101 AND 102).

FIRST USE 12-9-2010; IN COMMERCE 12-9-2010.

**CLASS 35—(Continued).**

3,942,244. COMMUNITY AGENCY NETWORK LLC, DBA COMMUNITY INSURANCE CENTERS, SOUTH WINDSOR, CT. SN 85-062,638. PUB. 11-16-2010, FILED 6-14-2010.

## PreNewal

THE MARK CONSISTS OF STANDARD CHARACTERS WITHOUT CLAIM TO ANY PARTICULAR FONT, STYLE, SIZE, OR COLOR.

FOR INSURANCE LEAD COLLECTION AND MATCHING SERVICES, NAMELY, MATCHING CONSUMER REQUESTS FOR INSURANCE POLICY QUOTES COLLECTED OVER THE INTERNET TO PRE-QUALIFIED INSURANCE BROKERS, AGENTS AND AGENCIES INTERESTED IN THOSE REQUESTS; MANAGING THE OPERATIONS OF INSURANCE AGENCIES AND BROKERS ON AN OUTSOURCING BASIS (U.S. CLS. 100, 101 AND 102).

FIRST USE 9-1-2010; IN COMMERCE 9-1-2010.

3,942,254. QUALITY BICYCLE PRODUCTS, INC., BLOOMINGTON, MN. SN 85-065,644. PUB. 11-23-2010, FILED 6-17-2010.

## Q-OUTDOOR

THE MARK CONSISTS OF STANDARD CHARACTERS WITHOUT CLAIM TO ANY PARTICULAR FONT, STYLE, SIZE, OR COLOR.

OWNER OF U.S. REG. NOS. 3,394,049 AND 3,394,050. FOR WHOLESALE DISTRIBUTORSHIPS FEATURING PRODUCTS IN THE FIELDS OF CAMPING, HIKING, CROSS-COUNTRY SKIING AND BICYCLE TOURING (U.S. CLS. 100, 101 AND 102).

FIRST USE 7-1-2010; IN COMMERCE 7-1-2010.

3,942,265. CORPORATE BROKERS, LLC, ANNAPOLIS, MD. SN 85-070,145. PUB. 11-16-2010, FILED 6-23-2010.

## LIVE. LOVE. EARN.

THE MARK CONSISTS OF STANDARD CHARACTERS WITHOUT CLAIM TO ANY PARTICULAR FONT, STYLE, SIZE, OR COLOR.

FOR PROFESSIONAL STAFFING AND RECRUITING SERVICES (U.S. CLS. 100, 101 AND 102).

FIRST USE 10-15-2010; IN COMMERCE 10-15-2010.

**CLASS 35—(Continued).**

3,942,289. TARGET BRANDS, INC., MINNEAPOLIS, MN. SN 85-075,945. PUB. 11-2-2010, FILED 7-1-2010.

## VALENBOWL

THE MARK CONSISTS OF STANDARD CHARACTERS WITHOUT CLAIM TO ANY PARTICULAR FONT, STYLE, SIZE, OR COLOR.

FOR RETAIL STORE SERVICES FEATURING A WIDE VARIETY OF CONSUMER GOODS; ONLINE RETAIL STORE SERVICES FEATURING A WIDE VARIETY OF CONSUMER GOODS (U.S. CLS. 100, 101 AND 102).

FIRST USE 2-1-2011; IN COMMERCE 2-1-2011.

3,942,296. OMNICOM MEDIA GROUP HOLDINGS INC., NEW YORK, NY. SN 85-080,412. PUB. 12-7-2010, FILED 7-8-2010.

## AIRWAVE

THE MARK CONSISTS OF STANDARD CHARACTERS WITHOUT CLAIM TO ANY PARTICULAR FONT, STYLE, SIZE, OR COLOR.

FOR MEDIA PLANNING AND BUYING SERVICES, NAMELY, PROVIDING SERVICES IN THE NATURE OF FACILITATING THE PLANNING, BUYING AND SELLING OF MEDIA FOR THIRD PARTIES (U.S. CLS. 100, 101 AND 102).

FIRST USE 7-27-2010; IN COMMERCE 7-27-2010.

3,942,323. DONATION MATCH, INC., SAN DIEGO, CA. SN 85-104,676. PUB. 11-2-2010, FILED 8-11-2010.

## Events with Benefits

THE MARK CONSISTS OF STANDARD CHARACTERS WITHOUT CLAIM TO ANY PARTICULAR FONT, STYLE, SIZE, OR COLOR.

FOR PROMOTING THE CHARITABLE GIVING OF OTHERS, NAMELY, TRACKING AND PUBLICIZING CHARITABLE DONATIONS AND RANDOM ACTS OF KINDNESS; PROMOTING THE CHARITABLE SERVICES OF OTHERS, NAMELY, PROVIDING INDIVIDUALS WITH INFORMATION FOR THE PURPOSE OF MAKING DONATIONS TO CHARITIES; PROMOTING THE PARTIES AND SPECIAL EVENTS OF OTHERS; PROVIDING MARKETING AND PROMOTION OF SPECIAL EVENTS (U.S. CLS. 100, 101 AND 102).

FIRST USE 1-11-2011; IN COMMERCE 1-11-2011.

**CLASS 36—INSURANCE AND FINANCIAL**

3,940,995. MILLER, PETER W., AIKEN, SC. SN 76-700,502.  
PUB. 11-16-2010, FILED 11-23-2009.



NO CLAIM IS MADE TO THE EXCLUSIVE RIGHT TO USE "AUTOMOBILE FINANCING", APART FROM THE MARK AS SHOWN.

THE COLOR(S) BLACK, WHITE, GREEN AND GRAY IS/ARE CLAIMED AS A FEATURE OF THE MARK.

THE MARK CONSISTS OF A GRAY AND WHITE KEY RING ATTACHED TO THE TOP PORTION OF A KEY IN BLACK. FOLLOWING THE TOP OF THE KEY IS THE LETTERING "PAC" IN GREEN, OUTLINED IN BLACK, WITH THE REMAINING PORTION OF THE KEY IN GRAY AND WHITE, EMITTING FROM THE INTERIOR OF THE LETTER "C". BENEATH THIS WORDING AND DESIGN ARE THE WORDS "THE KEY TO AUTOMOBILE FINANCING" IN BLACK.

FOR AUTOMOBILE FINANCING (U.S. CLS. 100, 101 AND 102).

FIRST USE 1-8-2007; IN COMMERCE 1-8-2007.

---

3,941,036. MONEY GROUP, INC., POMONA, CA. SN 77-222,883. PUB. 5-20-2008, FILED 7-5-2007.

**I TRACK SUCCESS**

THE MARK CONSISTS OF STANDARD CHARACTERS WITHOUT CLAIM TO ANY PARTICULAR FONT, STYLE, SIZE, OR COLOR.

FOR BANKING AND FINANCIAL SERVICES PROVIDED VIA KIOSKS, NAMELY, ISSUING PREPAID STORED VALUE CARDS; PROVIDING FINANCIAL CONSULTING SERVICES IN THE FIELD OF CONSUMER BUDGET PLANNING AND BUDGET MANAGEMENT SERVICES; BILL PAYMENT SERVICES; CURRENCY TRANSFER SERVICES; CHECK CASHING (U.S. CLS. 100, 101 AND 102).

FIRST USE 9-1-2009; IN COMMERCE 9-1-2009.

**CLASS 36—(Continued).**

3,941,060. WHITE, LESTER, ANDREWS, NC. SN 77-360,492.  
PUB. 5-13-2008, FILED 12-27-2007.

**got doobie?**

THE MARK CONSISTS OF STANDARD CHARACTERS WITHOUT CLAIM TO ANY PARTICULAR FONT, STYLE, SIZE, OR COLOR.

FOR BAIL BONDING (U.S. CLS. 100, 101 AND 102).  
FIRST USE 1-1-2005; IN COMMERCE 1-1-2005.

---

3,941,066. OPUS EVENTS INTERNATIONAL, INC., TIBURON, CA. SN 77-388,248. PUB. 6-17-2008, FILED 2-4-2008.

**WORLD WITHOUT BORDERS**

THE MARK CONSISTS OF STANDARD CHARACTERS WITHOUT CLAIM TO ANY PARTICULAR FONT, STYLE, SIZE, OR COLOR.

FOR CHARITABLE FUNDRAISING SERVICES BY MEANS OF MUSICAL CONCERTS AND ENTERTAINMENT EVENTS FOR COMMERCIAL, CORPORATE AND PRIVATE CLIENTS; ALL OF WHICH EXCLUDES CHARITABLE FUNDRAISING IN CONNECTION WITH MEDICAL CARE AND HEALTH CARE THAT IS ASSOCIATED WITH INTERNATIONAL RELIEF PROJECTS AND EXCLUDES CHARITABLE FUNDRAISING THAT IS TARGETED TO ASSISTING VICTIMS OF DISASTERS AND CONFLICTS IN UNDERDEVELOPED COUNTRIES (U.S. CLS. 100, 101 AND 102).

FIRST USE 10-1-2007; IN COMMERCE 8-1-2010.

---

3,941,118. MAIN STREET ACQUISITION CORP., LAS VEGAS, NV. SN 77-543,893. PUB. 11-10-2009, FILED 8-11-2008.

**MAIN STREET ACQUISITION CORP.**

THE MARK CONSISTS OF STANDARD CHARACTERS WITHOUT CLAIM TO ANY PARTICULAR FONT, STYLE, SIZE, OR COLOR.

OWNER OF U.S. REG. NO. 3,274,547.

**CLASS 36—(Continued).**

NO CLAIM IS MADE TO THE EXCLUSIVE RIGHT TO USE "ACQUISITION CORP.", APART FROM THE MARK AS SHOWN.

FOR FINANCIAL SERVICES, NAMELY, RESTRUCTURING EXISTING LOANS AND ACQUIRING AND COLLECTING RECEIVABLES FOR SECURED AND UNSECURED, NON-PERFORMING AND SUB-PERFORMING, CONSUMER AND COMMERCIAL DEBT (U.S. CLS. 100, 101 AND 102).

FIRST USE 3-15-2005; IN COMMERCE 3-15-2005.

3,941,218. NATIONWIDE MUTUAL INSURANCE COMPANY, COLUMBUS, OH. SN 77-666,524. PUB. 6-30-2009, FILED 2-9-2009.

**CALFARM**

THE MARK CONSISTS OF STANDARD CHARACTERS WITHOUT CLAIM TO ANY PARTICULAR FONT, STYLE, SIZE, OR COLOR.

FOR INSURANCE SERVICES, NAMELY, INSURANCE UNDERWRITING, CLAIMS ADMINISTRATION, LOSS CONTROL MANAGEMENT FOR OTHERS, AND BROKERAGE SUPPORT IN THE FIELDS OF AUTO, HOME, FARM, BUSINESS, LIFE, PROPERTY AND CASUALTY, AND INLAND MARINE INSURANCE (U.S. CLS. 100, 101 AND 102).

FIRST USE 2-8-2011; IN COMMERCE 2-8-2011.

3,941,236. BONNEVILLE ENVIRONMENTAL FOUNDATION, PORTLAND, OR. SN 77-685,540. PUB. 5-4-2010, FILED 3-6-2009.

**WATER RESTORATION  
CERTIFICATES**

THE MARK CONSISTS OF STANDARD CHARACTERS WITHOUT CLAIM TO ANY PARTICULAR FONT, STYLE, SIZE, OR COLOR.

NO CLAIM IS MADE TO THE EXCLUSIVE RIGHT TO USE "WATER" AND "CERTIFICATES", APART FROM THE MARK AS SHOWN.

FOR BROKERAGE OF EXCESS WATER RIGHTS (U.S. CLS. 100, 101 AND 102).

FIRST USE 3-27-2009; IN COMMERCE 6-17-2009.

**CLASS 36—(Continued).**

3,941,277. LIBERTA FAMILY OFFICES SERVICES COMPANY, CHICAGO, IL. SN 77-743,334. PUB. 10-27-2009, FILED 5-22-2009.

**Libertà Family Office  
Services**

THE MARK CONSISTS OF STANDARD CHARACTERS WITHOUT CLAIM TO ANY PARTICULAR FONT, STYLE, SIZE, OR COLOR.

NO CLAIM IS MADE TO THE EXCLUSIVE RIGHT TO USE "FAMILY OFFICE SERVICES", APART FROM THE MARK AS SHOWN.

THE ENGLISH TRANSLATION OF "LIBERTÀ" IN THE MARK IS "FREEDOM".

FOR FINANCIAL SERVICES, NAMELY, WEALTH PLANNING AND FINANCIAL MANAGEMENT STRATEGIES; SMALL BUSINESS SERVICES, NAMELY, INVOICE AND PAYROLL PROCESSING; ADMINISTRATION, BILLING AND RECONCILIATION OF ACCOUNTS ON BEHALF OF OTHERS; ANNUITY SERVICES, NAMELY, ACCOUNT AND INVESTMENT ADMINISTRATION; ELECTRONIC COMMERCE PAYMENT SERVICES, NAMELY, ESTABLISHING FUNDED ACCOUNTS USED TO PURCHASE GOODS AND SERVICES ON THE INTERNET (U.S. CLS. 100, 101 AND 102).

FIRST USE 8-12-2010; IN COMMERCE 8-12-2010.

3,941,279. LIBERTA FAMILY OFFICES SERVICES COMPANY, CHICAGO, IL. SN 77-744,522. PUB. 10-27-2009, FILED 5-26-2009.



NO CLAIM IS MADE TO THE EXCLUSIVE RIGHT TO USE "FAMILY OFFICE SERVICES", APART FROM THE MARK AS SHOWN.

THE COLOR(S) BLACK AND BLUE IS/ARE CLAIMED AS A FEATURE OF THE MARK.

THE MARK CONSISTS OF "LIBERTÀ FAMILY OFFICE SERVICES" IN BLACK COLOR AND THE FIGURE OF A BIRD IN BLUE COLOR.

THE ENGLISH TRANSLATION OF "LIBERTÀ" IN THE MARK IS "FREEDOM".

FOR FINANCIAL SERVICES, NAMELY, WEALTH PLANNING AND FINANCIAL MANAGEMENT STRATEGIES; SMALL BUSINESS SERVICES, NAMELY, INVOICE AND PAYROLL PROCESSING; ADMINISTRATION, BILLING AND RECONCILIATION OF ACCOUNTS ON BEHALF OF OTHERS; ANNUITY SERVICES, NAMELY, ACCOUNT AND INVESTMENT ADMINISTRATION; ELECTRONIC COMMERCE PAYMENT SERVICES, NAMELY, ESTABLISHING FUNDED ACCOUNTS USED TO PURCHASE GOODS AND SERVICES ON THE INTERNET (U.S. CLS. 100, 101 AND 102).

FIRST USE 5-19-2010; IN COMMERCE 5-19-2010.



**CLASS 36—(Continued).**

3,941,288. US AIRWAYS, INC., TEMPE, AZ. SN 77-753,416.  
PUB. 5-25-2010, FILED 6-5-2009.

**DIVIDEND MILES SELECT**

THE MARK CONSISTS OF STANDARD CHARACTERS WITHOUT CLAIM TO ANY PARTICULAR FONT, STYLE, SIZE, OR COLOR.

OWNER OF U.S. REG. NOS. 2,241,014, 2,269,473, AND 2,865,418.

FOR CREDIT CARD SERVICES (U.S. CLS. 100, 101 AND 102).

FIRST USE 7-1-2009; IN COMMERCE 7-1-2009.

3,941,291. ALGER ASSOCIATES, INC., NEW YORK, NY. SN 77-754,429. PUB. 11-3-2009, FILED 6-8-2009.

**INSPIRED BY CHANGE, DRIVEN BY GROWTH**

THE MARK CONSISTS OF STANDARD CHARACTERS WITHOUT CLAIM TO ANY PARTICULAR FONT, STYLE, SIZE, OR COLOR.

FOR MUTUAL FUND INVESTMENT, STOCK BROKERAGE, FINANCIAL MANAGEMENT AND INVESTMENT ADVICE (U.S. CLS. 100, 101 AND 102).

FIRST USE 6-30-2009; IN COMMERCE 6-30-2009.

3,941,294. DAVID BAKER, BEND, OR. SN 77-755,591. PUB. 5-25-2010, FILED 6-9-2009.



NO CLAIM IS MADE TO THE EXCLUSIVE RIGHT TO USE "COIN MERCANTILE", APART FROM THE MARK AS SHOWN.

THE COLOR(S) WHITE, BROWN, GOLD AND GRAY IS/ ARE CLAIMED AS A FEATURE OF THE MARK.

**CLASS 36—(Continued).**

THE MARK CONSISTS OF A LARGE GOLD COIN DESIGN OUTLINED IN BROWN WHICH INCLUDES THE WORDS "COIN MERCANTILE" IN GOLD LETTERS FORMING THE BORDER INSIDE THE COIN AND THE WORD "COINMERC" IN GOLD LETTERS IN THE CENTER OF THE COIN OVER A CIRCULAR BACKGROUND WHICH APPEARS IN WHITE AT THE TOP AND FADES TO DARK GRAY.

FOR FINANCIAL SERVICES, NAMELY, EXCHANGE QUOTATIONS FOR PRECIOUS METAL MODERN WORLD COINS; CURRENCY FUTURES EXCHANGE MARKET SERVICES, NAMELY, AGENCIES OR BROKERAGE FOR TRADING PRECIOUS METAL MODERN WORLD COINS FUTURES; SECURITIES AND COMMODITY TRADING FOR OTHERS, CLEARING AND SETTLEMENT OF SECURITIES TRADES, AND ASSISTING OTHERS WITH THE COMPLETION OF FINANCIAL TRANSACTIONS FOR SECURITIES AND EQUITIES, NAMELY, AGENCY SERVICES FOR PRECIOUS METAL MODERN WORLD COINS TRADING INCLUDING THE BUYING AND SELLING OF PRECIOUS METAL MODERN WORLD COINS; FINANCIAL INFORMATION PROCESSING, NAMELY, FINANCIAL INFORMATION MANAGEMENT AND ANALYSIS SERVICES RELATED TO PRECIOUS METAL MODERN WORLD COINS (U.S. CLS. 100, 101 AND 102).

FIRST USE 1-13-2011; IN COMMERCE 1-13-2011.

3,941,304. CNA FINANCIAL CORPORATION, CHICAGO, IL. SN 77-759,737. PUB. 6-1-2010, FILED 6-15-2009.

**CNA SELECT RISK**

THE MARK CONSISTS OF STANDARD CHARACTERS WITHOUT CLAIM TO ANY PARTICULAR FONT, STYLE, SIZE, OR COLOR.

OWNER OF U.S. REG. NOS. 802,010, 1,043,744, AND 2,169,594.

NO CLAIM IS MADE TO THE EXCLUSIVE RIGHT TO USE "RISK", APART FROM THE MARK AS SHOWN.

FOR UNDERWRITING AND CLAIMS ADMINISTRATION SERVICES FOR EXCESS AND SURPLUS INSURANCE PROGRAMS, INCLUDING WHOLESALE PROPERTY; INSURANCE WHOLESALE AGENCY AND BROKERAGE SERVICES (U.S. CLS. 100, 101 AND 102).

FIRST USE 9-30-2010; IN COMMERCE 9-30-2010.

**CLASS 36—(Continued).**

3,941,411. LANGSFELD & ASSOCIATES, LTD., INCLINE VILLAGE, NV. SN 77-800,380. PUB. 8-17-2010, FILED 8-9-2009.

**COMMISSIONCAPTURE**

THE MARK CONSISTS OF STANDARD CHARACTERS WITHOUT CLAIM TO ANY PARTICULAR FONT, STYLE, SIZE, OR COLOR.

FOR FINANCIAL CONSULTING PERTAINING TO COMMISSION RECOVERY AND COLLECTION SERVICES FROM HOTELS FOR TRAVEL AGENCIES AND COMPANIES BOOKING HOTEL RESERVATION (U.S. CLS. 100, 101 AND 102).

FIRST USE 7-20-2009; IN COMMERCE 7-20-2009.

3,941,430. ONBEST TECHNOLOGY HOLDINGS LIMITED, HONG KONG, HONG KONG. SN 77-807,545. PUB. 6-1-2010, FILED 8-18-2009.

**POPURCHASE**

THE MARK CONSISTS OF STANDARD CHARACTERS WITHOUT CLAIM TO ANY PARTICULAR FONT, STYLE, SIZE, OR COLOR.

FOR FINANCIAL ADVICE AND CONSULTANCY SERVICES; FINANCIAL ANALYSIS AND CREDIT CONSULTATION; FINANCIAL RESEARCH SERVICES; FINANCIAL ASSET MANAGEMENT; FINANCIAL EVALUATION FOR INSURANCE PURPOSES; FINANCIAL EXCHANGE; FINANCIAL FORECASTING; FINANCIAL INFORMATION PROVIDED BY ELECTRONIC MEANS; FINANCIAL INFORMATION PROCESSING; FINANCIAL RISK MANAGEMENT; FINANCIAL ADMINISTRATION OF RETIREMENT PLANS; FINANCIAL SERVICES, NAMELY, PROVIDING ON-LINE STORED VALUE ACCOUNTS IN AN ELECTRONIC ENVIRONMENT, INVESTMENT FUND TRANSFER AND TRANSACTION SERVICES, ASSISTING OTHERS WITH THE COMPLETION OF FINANCIAL TRANSACTIONS FOR STOCKS, BONDS, SECURITIES AND EQUITIES, ISSUANCE AND MANAGEMENT OF CERTIFICATES BACKED BY LOAN PORTFOLIOS WHICH ARE SUBSEQUENTLY MANAGED TO INSURE THE INTEGRITY OF THE CERTIFICATES, PROVIDING FOR THE EXCHANGE OF FOREIGN CURRENCY, COMMODITIES, FINANCIAL DERIVATIVES, INTEREST RATE PRODUCTS, AND EQUITIES VIA THE INTERNET AND INTRANET SYSTEMS, PROVIDING A VIRTUAL CURRENCY FOR USE BY MEMBERS OF AN ON-LINE COMMUNITY VIA A GLOBAL COMPUTER NETWORK, BUSINESS FUND RAISING PROVIDED OVER A COMPUTER NETWORK SUCH AS THE INTERNET, ELECTRONIC REMOTE CHECK DEPOSIT SER-

**CLASS 36—(Continued).**

VICES, FUNDING ONLINE CASH ACCOUNTS FROM PREPAID CASH CARDS, BANK ACCOUNTS AND CREDIT CARD ACCOUNTS, PROVIDING SECURE COMMERCIAL TRANSACTIONS AND PAYMENT OPTIONS USING A MOBILE DEVICE AT A POINT OF SALE; ON-LINE FINANCIAL PLANNING SERVICES; PROVIDING A WEB SITE THAT ASSISTS FINANCIAL PROFESSIONALS IN THE MANAGEMENT OF RETIREMENT ACCOUNTS; PROVIDING A WEB SITE FEATURING PERSONAL FINANCIAL INFORMATION AND FINANCIAL ADVICE; PROVIDING FINANCIAL RISK MANAGEMENT SERVICES FOR ELECTRONIC FUNDS TRANSFER, CREDIT AND DEBIT CARD AND ELECTRONIC CHECK TRANSACTIONS VIA A GLOBAL COMPUTER NETWORK; PROVIDING INFORMATION AND ADVICE IN THE FIELD OF FINANCE, FINANCIAL INVESTMENTS, FINANCIAL VALUATIONS, AND THE FINANCIAL ASPECTS OF RETIREMENT; PROVIDING INFORMATION ON GOVERNMENT FINANCIAL ASSISTANCE PROGRAMS; PROVIDING ON-LINE FINANCIAL CALCULATORS (U.S. CLS. 100, 101 AND 102).  
FIRST USE 9-30-2010; IN COMMERCE 9-30-2010.

3,941,491. MILLHISER-SMITH AGENCY, INC., CEDAR RAPIDS, IA. SN 77-846,650. PUB. 3-23-2010, FILED 10-12-2009.

**DiscoverRisk**

THE MARK CONSISTS OF STANDARD CHARACTERS WITHOUT CLAIM TO ANY PARTICULAR FONT, STYLE, SIZE, OR COLOR.

FOR CONSULTING AND INFORMATION CONCERNING INSURANCE (U.S. CLS. 100, 101 AND 102).

FIRST USE 11-1-2010; IN COMMERCE 11-1-2010.

3,941,508. ASHLAND LICENSING AND INTELLECTUAL PROPERTY LLC, DUBLIN, OH. SN 77-853,451. PUB. 6-1-2010, FILED 10-21-2009.

**FUEL  
PROOF  
GUARANTEE**

NO CLAIM IS MADE TO THE EXCLUSIVE RIGHT TO USE "GUARANTEE", APART FROM THE MARK AS SHOWN.

**CLASS 36—(Continued).**

THE MARK CONSISTS OF THE WORDS "FUEL PROOF GUARANTEE" WITH A LOCK HANGING OFF THE LETTER "U" OF THE WORD "FUEL" MAKING UP THE FIRST "O" IN THE WORD "PROOF". THE FUEL GAUGE ENCLOSES THE "E" AND "F" DESIGNATIONS AND HASH MARKS ALONG WITH A FUEL PUMP REPRESENTATION AND THE WORD "DIESEL" ON THE BODY OF THE GAUGE.

FOR PROVIDING A VEHICLE FUEL ECONOMY SATISFACTION GUARANTEE PROGRAM FOR THE TRANSPORTATION INDUSTRY, NAMELY, FOR THOSE WHO USE THE SPECIFIED LUBRICANTS AND MEASURING EQUIPMENT, AND ADHERE TO THE GUIDELINES OF THE PROGRAM (U.S. CLS. 100, 101 AND 102).  
FIRST USE 1-5-2009; IN COMMERCE 11-5-2009.

**CLASS 36—(Continued).**

3,941,516. THE FILLIES, INC., LOUISVILLE, KY. SN 77-857,022. PUB. 5-4-2010, FILED 10-26-2009.

**DERBY PRINCESSES**

3,941,510. DAVIDAN CORPORATION, PHOENIX, AZ. SN 77-854,992. PUB. 8-3-2010, FILED 10-22-2009.



NO CLAIM IS MADE TO THE EXCLUSIVE RIGHT TO USE "PAYMENT SYSTEMS", APART FROM THE MARK AS SHOWN.

THE MARK CONSISTS OF THE STYLIZED WORDING "OLYMPUS PAYMENT SYSTEMS" AND THE DESIGN OF A MOUNTAIN INSIDE THE "O".

FOR CREDIT CARD PAYMENT PROCESSING SERVICES FOR MERCHANTS (U.S. CLS. 100, 101 AND 102).  
FIRST USE 8-15-2009; IN COMMERCE 8-15-2009.

THE MARK CONSISTS OF STANDARD CHARACTERS WITHOUT CLAIM TO ANY PARTICULAR FONT, STYLE, SIZE, OR COLOR.

FOR CHARITABLE FUND-RAISING SERVICES, NAMELY, ORGANIZING AND CONDUCTING PAGEANTS, PARADES, DANCES, BALLROOM DANCES, AND FESTIVALS (U.S. CLS. 100, 101 AND 102).

FIRST USE 12-22-2010; IN COMMERCE 12-22-2010.

3,941,597. LMGH, LLC, TAMPA, FL. SN 77-880,784. PUB. 4-13-2010, FILED 11-25-2009.

3,941,515. AMERICAN WHEELCHAIR FOUNDATION, CAMARILLO, CA. SN 77-856,897. PUB. 4-13-2010, FILED 10-26-2009.

**Mobility Heroes**

THE MARK CONSISTS OF STANDARD CHARACTERS WITHOUT CLAIM TO ANY PARTICULAR FONT, STYLE, SIZE, OR COLOR.

FOR CHARITABLE FUND RAISING FOR DISABLED PERSONS: CHARITABLE FUND RAISING SERVICES FOR DISABLED PERSONS BY MEANS OF AN ENTERTAINMENT EVENT (U.S. CLS. 100, 101 AND 102).  
FIRST USE 9-0-2010; IN COMMERCE 9-0-2010.

THE COLOR(S) BLUE AND GREEN IS/ARE CLAIMED AS A FEATURE OF THE MARK.

THE MARK CONSISTS OF THE WORD "CAPITAL" IN BLUE NEXT TO THE LETTERS "B" AND "A" IN GREEN NEXT TO THE NUMBER "6" WHICH IS IN GREEN WITHIN A BLUE CIRCLE OUTLINED IN GREEN, AND THERE IS A BLUE ARCH UNDER THE ENTIRE MARK "CAPITALBA6".

FOR OFFERING LEASE-WITH-OPTION-TO-PURCHASE CONTRACTS AND SERVICES TO CUSTOMERS OF THIRD PARTY SELLERS OF RETAIL GOODS, NAMELY, LEASE-PURCHASE FINANCING (U.S. CLS. 100, 101 AND 102).

FIRST USE 12-15-2009; IN COMMERCE 12-15-2009.

**CLASS 36—(Continued).**

3,941,662. SUE HAMILTON, CAMILLUS, NY. SN 77-895,713. PUB. 5-18-2010, FILED 12-17-2009.

DON'T SLACK PROTECT YOUR  
RACK

THE MARK CONSISTS OF STANDARD CHARACTERS WITHOUT CLAIM TO ANY PARTICULAR FONT, STYLE, SIZE, OR COLOR.

FOR CHARITABLE FUNDRAISING SERVICES BY MEANS OF SELLING T-SHIRTS TO RAISE FUNDS FOR BREAST CANCER RESEARCH AND SUPPORT (U.S. CLS. 100, 101 AND 102).

FIRST USE 1-10-2011; IN COMMERCE 1-10-2011.

---

3,941,684. COMMONWEALTH GENERAL CORPORATION, LOUISVILLE, KY. SN 77-898,913. PUB. 5-18-2010, FILED 12-22-2009.

MOMSURANCE

THE MARK CONSISTS OF STANDARD CHARACTERS WITHOUT CLAIM TO ANY PARTICULAR FONT, STYLE, SIZE, OR COLOR.

FOR INSURANCE SERVICES, NAMELY, BROKERAGE, CLAIMS PROCESSING, CONSULTATION, UNDERWRITING AND ADMINISTRATION OF LIFE INSURANCE (U.S. CLS. 100, 101 AND 102).

FIRST USE 1-7-2010; IN COMMERCE 1-7-2010.

---

3,941,700. FIRSTMERIT CORPORATION, AKRON, OH. SN 77-901,294. PUB. 10-12-2010, FILED 12-28-2009.

AS INDIVIDUAL AS YOU

THE MARK CONSISTS OF STANDARD CHARACTERS WITHOUT CLAIM TO ANY PARTICULAR FONT, STYLE, SIZE, OR COLOR.

OWNER OF U.S. REG. NO. 3,174,639.

FOR BANKING; FINANCIAL SERVICES, NAMELY, CREDIT MANAGEMENT, RISK MANAGEMENT, TRUST AND ESTATE PLANNING, FINANCIAL PLANNING, INVESTMENT MANAGEMENT, RETIREMENT PLANNING, 401(K) ADVISORY SERVICES (U.S. CLS. 100, 101 AND 102).

FIRST USE 6-1-2009; IN COMMERCE 6-1-2009.

**CLASS 36—(Continued).**

3,941,742. MAZOOMA TECHNICAL SERVICES, INC, TORONTO, ONTARIO, CANADA. SN 77-909,671. PUB. 6-1-2010, FILED 1-12-2010.

mazooma.

OWNER OF U.S. REG. NO. 3,489,836.

THE COLOR(S) BLUE IS/ARE CLAIMED AS A FEATURE OF THE MARK.

THE MARK CONSISTS OF "MAZOOMA" IN BLUE LETTERS FOLLOWED BY A PERIOD WITH A DARK BLUE BORDER AND INNER BLUE COLOR.

THE WORDING "MAZOOMA" HAS NO MEANING IN A FOREIGN LANGUAGE.

FOR ELECTRONIC FUNDS TRANSFER; ELECTRONIC FUNDS TRANSFER BY TELECOMMUNICATIONS; FINANCIAL INFORMATION PROVIDED BY ELECTRONIC MEANS (U.S. CLS. 100, 101 AND 102).

FIRST USE 8-19-2010; IN COMMERCE 8-19-2010.

---

3,941,743. HOPE LOANPORT, INC., WASHINGTON, DC. SN 77-909,690. PUB. 10-12-2010, FILED 1-12-2010.



THE MARK CONSISTS OF THE WORDING "HOPE LOANPORT" BENEATH A CURVING PATH SET AGAINST ROLLING HILLS, TOPPED BY THE SUN AND A HOUSE.

FOR LOAN MODIFICATION SERVICES AND PROVIDING A WEB SITE THAT ALLOWS MORTGAGE COUNSELORS AND HOMEOWNERS AT RISK OF FORECLOSURE TO APPLY FOR LOAN MODIFICATIONS WITH THEIR LENDERS (U.S. CLS. 100, 101 AND 102).

FIRST USE 11-15-2009; IN COMMERCE 11-15-2009.

**CLASS 36—(Continued).**

3,941,794. SCOTTRADE, INC., ST. LOUIS, MO. SN 77-918,256.  
PUB. 6-8-2010, FILED 1-22-2010.

**SCOTTRADE BANK**

THE MARK CONSISTS OF STANDARD CHARACTERS WITHOUT CLAIM TO ANY PARTICULAR FONT, STYLE, SIZE, OR COLOR.

OWNER OF U.S. REG. NOS. 2,140,963, 2,940,785, AND OTHERS.

NO CLAIM IS MADE TO THE EXCLUSIVE RIGHT TO USE "BANK", APART FROM THE MARK AS SHOWN.

FOR BANKING (U.S. CLS. 100, 101 AND 102).  
FIRST USE 11-8-2010; IN COMMERCE 11-8-2010.

3,941,837. BUSINESS OWNERS LIABILITY TEAM LLC, FARMINGTON, CT. SN 77-923,705. PUB. 6-15-2010, FILED 1-29-2010.

**BOLT**

THE MARK CONSISTS OF STANDARD CHARACTERS WITHOUT CLAIM TO ANY PARTICULAR FONT, STYLE, SIZE, OR COLOR.

FOR ONLINE INSURANCE AGENCY SERVICES (U.S. CLS. 100, 101 AND 102).

FIRST USE 2-1-2010; IN COMMERCE 2-1-2010.

3,941,849. PALMER & CAY, LLC, ATLANTA, GA. SN 77-926,009. PUB. 6-15-2010, FILED 2-2-2010.



THE MARK CONSISTS OF THE WORDING "PALMER & CAY" SUPERIMPOSED IN FRONT OF A DESIGN OF A TRIANGULAR FLAG BEARING A CROSS AND SHIP.

FOR INSURANCE AGENCY AND BROKERAGE SERVICES OF COMMERCIAL PROPERTY, CASUALTY, AND SPECIALTY LINES OF INSURANCE; CONSULTING SERVICES REGARDING EMPLOYEE INSURANCE AND FINANCIAL BENEFITS (U.S. CLS. 100, 101 AND 102).

FIRST USE 3-0-2010; IN COMMERCE 4-0-2010.

**CLASS 36—(Continued).**

3,941,874. COMMUNITY & SOUTHERN BANK, CARROLLTON, GA. SN 77-930,479. PUB. 7-13-2010, FILED 2-8-2010.



NO CLAIM IS MADE TO THE EXCLUSIVE RIGHT TO USE "COMMUNITY", APART FROM THE MARK AS SHOWN.

THE MARK CONSISTS OF THE WORD "CSBANK", WITH THE LETTER "S" ABOVE, BETWEEN, AND INTERLOCKING THE LETTERS "C" AND "B", ALL ABOVE THE WORDS "COMMUNITY & SOUTHERN". THE MARK IS DISPLAYED ON A RECTANGULAR BACKGROUND WITH ROUNDED CORNERS.

FOR BANKING SERVICES (U.S. CLS. 100, 101 AND 102).

FIRST USE 1-30-2010; IN COMMERCE 1-30-2010.

3,941,880. COMMUNITY & SOUTHERN BANK, CARROLLTON, GA. SN 77-930,933. PUB. 6-29-2010, FILED 2-8-2010.

**CSBANK**

THE MARK CONSISTS OF STANDARD CHARACTERS WITHOUT CLAIM TO ANY PARTICULAR FONT, STYLE, SIZE, OR COLOR.

FOR BANKING SERVICES (U.S. CLS. 100, 101 AND 102).

FIRST USE 1-30-2010; IN COMMERCE 1-30-2010.

3,941,956. ALLSTATE INSURANCE COMPANY, NORTH-BROOK, IL. SN 77-952,778. PUB. 6-22-2010, FILED 3-8-2010.

**GOODFORLIFE**

THE MARK CONSISTS OF STANDARD CHARACTERS WITHOUT CLAIM TO ANY PARTICULAR FONT, STYLE, SIZE, OR COLOR.

FOR INSURANCE SERVICES, NAMELY, UNDERWRITING, ISSUING AND ADMINISTRATION OF LIFE INSURANCE, CRITICAL CARE INSURANCE, AND ACCIDENTAL DEATH AND INJURY INSURANCE (U.S. CLS. 100, 101 AND 102).

FIRST USE 7-12-2010; IN COMMERCE 7-12-2010.

**CLASS 36—(Continued).**

3,941,972. MABE, LLC, CINCINNATI, OH. SN 77-958,785. PUB. 8-3-2010, FILED 3-15-2010.

**CEO SECRETS**

THE MARK CONSISTS OF STANDARD CHARACTERS WITHOUT CLAIM TO ANY PARTICULAR FONT, STYLE, SIZE, OR COLOR.

NO CLAIM IS MADE TO THE EXCLUSIVE RIGHT TO USE "CEO", APART FROM THE MARK AS SHOWN.

FOR FINANCIAL ANALYSIS AND CONSULTATION (U.S. CLS. 100, 101 AND 102).

FIRST USE 4-0-2010; IN COMMERCE 4-0-2010.

**CLASS 36—(Continued).**

3,942,084. THE LEUKEMIA & LYMPHOMA SOCIETY, INC., WHITE PLAINS, NY. SN 85-004,009. PUB. 11-23-2010, FILED 4-1-2010.

**TAKING STEPS TO CURE CANCER**

THE MARK CONSISTS OF STANDARD CHARACTERS WITHOUT CLAIM TO ANY PARTICULAR FONT, STYLE, SIZE, OR COLOR.

OWNER OF U.S. REG. NO. 3,718,411. FOR CHARITABLE FUND RAISING (U.S. CLS. 100, 101 AND 102).

FIRST USE 2-28-2010; IN COMMERCE 2-28-2010.

3,941,978. SUPERMEDIA LLC, DFW AIRPORT, TX. SN 77-960,968. PUB. 8-3-2010, FILED 3-17-2010.

**SUPERTRACKING**

THE MARK CONSISTS OF STANDARD CHARACTERS WITHOUT CLAIM TO ANY PARTICULAR FONT, STYLE, SIZE, OR COLOR.

FOR PROVIDING DATA ON INCOMING CALLS TO A BUSINESS AS A RESULT OF ADVERTISING AND MARKETING CAMPAIGNS (U.S. CLS. 100, 101 AND 102).

FIRST USE 3-0-2010; IN COMMERCE 3-0-2010.

3,942,098. WEALTH STRONG DEVELOPMENT, INC., LITTLETON, CO. SN 85-009,056. PUB. 8-31-2010, FILED 4-8-2010.

**WHEN-Score**

THE MARK CONSISTS OF STANDARD CHARACTERS WITHOUT CLAIM TO ANY PARTICULAR FONT, STYLE, SIZE, OR COLOR.

FOR FINANCIAL RESEARCH AND INFORMATION SERVICES (U.S. CLS. 100, 101 AND 102).

FIRST USE 4-8-2010; IN COMMERCE 10-1-2010.

3,942,070. ANTONAKOS FLORIDAN, LLC, TAMPA, FL. SN 78-934,006. PUB. 2-20-2007, FILED 7-20-2006.

**FLORIDAN**

THE MARK CONSISTS OF STANDARD CHARACTERS WITHOUT CLAIM TO ANY PARTICULAR FONT, STYLE, SIZE, OR COLOR.

FOR REAL ESTATE SERVICES, NAMELY, LISTING, LEASING, BROKERAGE, AND MANAGEMENT OF RESIDENTIAL AND COMMERCIAL CONDOMINIUM UNITS (U.S. CLS. 100, 101 AND 102).

FIRST USE 5-10-2010; IN COMMERCE 5-10-2010.

3,942,116. CYSTIC FIBROSIS FOUNDATION, BETHESDA, MD. SN 85-017,990. PUB. 9-21-2010, FILED 4-20-2010.

**CF CYCLE FOR LIFE**

THE MARK CONSISTS OF STANDARD CHARACTERS WITHOUT CLAIM TO ANY PARTICULAR FONT, STYLE, SIZE, OR COLOR.

FOR CHARITABLE FUND RAISING SERVICES (U.S. CLS. 100, 101 AND 102).

FIRST USE 8-0-2010; IN COMMERCE 8-0-2010.

**CLASS 36—(Continued).**

3,942,123. AMGEN INC., THOUSAND OAKS, CA. SN 85-022,876. PUB. 9-21-2010, FILED 4-26-2010.

## AMGEN VENTURES

THE MARK CONSISTS OF STANDARD CHARACTERS WITHOUT CLAIM TO ANY PARTICULAR FONT, STYLE, SIZE, OR COLOR.

OWNER OF U.S. REG. NOS. 1,621,967, 3,180,419, AND OTHERS.

NO CLAIM IS MADE TO THE EXCLUSIVE RIGHT TO USE "VENTURES", APART FROM THE MARK AS SHOWN.

FOR VENTURE CAPITAL SERVICES, NAMELY, PROVIDING FINANCING TO EMERGING AND START-UP COMPANIES; VENTURE CAPITAL ADVISORY SERVICES (U.S. CLS. 100, 101 AND 102).

FIRST USE 0-0-2004; IN COMMERCE 0-0-2004.

3,942,144. CAPITAL ADVISORS GROUP, INC., NEWTON, MA. SN 85-030,622. PUB. 10-5-2010, FILED 5-5-2010.

## FundIQ

THE MARK CONSISTS OF STANDARD CHARACTERS WITHOUT CLAIM TO ANY PARTICULAR FONT, STYLE, SIZE, OR COLOR.

FOR FINANCIAL PORTFOLIO ANALYSIS SERVICES (U.S. CLS. 100, 101 AND 102).

FIRST USE 5-17-2010; IN COMMERCE 5-17-2010.

3,942,165. ALPINE INVESTMENT MANAGEMENT, LLC, ST. LOUIS, MO. SN 85-041,691. PUB. 10-19-2010, FILED 5-18-2010.

## ALPINE CAPITAL RESEARCH

THE MARK CONSISTS OF STANDARD CHARACTERS WITHOUT CLAIM TO ANY PARTICULAR FONT, STYLE, SIZE, OR COLOR.

OWNER OF U.S. REG. NO. 2,458,044.

**CLASS 36—(Continued).**

NO CLAIM IS MADE TO THE EXCLUSIVE RIGHT TO USE "CAPITAL RESEARCH", APART FROM THE MARK AS SHOWN.

FOR FINANCIAL SERVICES, NAMELY, INVESTMENT MANAGEMENT AND INVESTMENT ADVICE; FINANCIAL INVESTMENT IN THE FIELD OF SECURITIES FOR INDIVIDUALS AND INSTITUTIONS; FINANCIAL AFFAIRS, NAMELY, PRIVATE EQUITY FUND MANAGEMENT AND INVESTMENT; SECURITIES BROKERAGE; FINANCIAL ANALYSIS AND CONSULTATION; FINANCIAL AND INVESTMENT SERVICES, NAMELY, MANAGEMENT AND BROKERAGE IN THE FIELDS OF STOCK, BONDS, OPTIONS, COMMODITIES, FUTURES AND OTHER SECURITIES, AND THE INVESTMENT OF FUNDS OF OTHERS (U.S. CLS. 100, 101 AND 102).

FIRST USE 3-1-2009; IN COMMERCE 3-1-2009.

3,942,169. LOCAL MUZ, LLC, SOUTH LYME, CT. SN 85-043,680. PUB. 10-19-2010, FILED 5-20-2010.

## BRING OUR MUSIC BACK

THE MARK CONSISTS OF STANDARD CHARACTERS WITHOUT CLAIM TO ANY PARTICULAR FONT, STYLE, SIZE, OR COLOR.

FOR CHARITABLE FUND RAISING SERVICES BY MEANS OF MUSICAL CONCERTS (U.S. CLS. 100, 101 AND 102).

FIRST USE 5-20-2009; IN COMMERCE 5-20-2009.

**CLASS 36—(Continued).**

3,942,189. NIP GROUP, INC., WOODBRIDGE, NJ. SN 85-047,907. PUB. 9-28-2010, FILED 5-26-2010.

# MedEdge

THE MARK CONSISTS OF STANDARD CHARACTERS WITHOUT CLAIM TO ANY PARTICULAR FONT, STYLE, SIZE, OR COLOR.

FOR INSURANCE ADMINISTRATION IN THE FIELD OF PROFESSIONAL LIABILITY INSURANCE TO HEALTH CARE PRACTITIONERS, INCLUDING PHYSICIAN ASSISTANTS, NURSE PRACTITIONERS, OPTOMETRISTS, AND PODIATRISTS AND NOT INCLUDING HEALTH CARE BENEFITS, HEALTH INSURANCE OR PHARMACY BENEFIT INSURANCE; INSURANCE AGENCIES IN THE FIELD OF PROFESSIONAL LIABILITY INSURANCE TO HEALTH CARE PRACTITIONERS, INCLUDING PHYSICIAN ASSISTANTS, NURSE PRACTITIONERS, OPTOMETRISTS, AND PODIATRISTS AND NOT INCLUDING HEALTH CARE BENEFITS, HEALTH INSURANCE OR PHARMACY BENEFIT INSURANCE; INSURANCE BROKERAGE IN THE FIELD OF PROFESSIONAL LIABILITY INSURANCE TO HEALTH CARE PRACTITIONERS, INCLUDING PHYSICIAN ASSISTANTS, NURSE PRACTITIONERS, OPTOMETRISTS, AND PODIATRISTS AND NOT INCLUDING HEALTH CARE BENEFITS, HEALTH INSURANCE OR PHARMACY BENEFIT INSURANCE; INSURANCE UNDERWRITING IN THE FIELD OF PROFESSIONAL LIABILITY INSURANCE TO HEALTH CARE PRACTITIONERS, INCLUDING PHYSICIAN ASSISTANTS, NURSE PRACTITIONERS, OPTOMETRISTS, AND PODIATRISTS AND NOT INCLUDING HEALTH CARE BENEFITS, HEALTH INSURANCE OR PHARMACY BENEFIT INSURANCE (U.S. CLS. 100, 101 AND 102).

FIRST USE 10-14-2010; IN COMMERCE 10-14-2010.

3,942,223. THE COMMUNITY FOUNDATION FOR GREATER NEW HAVEN, INC., NEW HAVEN, CT. SN 85-054,316. PUB. 11-9-2010, FILED 6-3-2010.

# GIVEGREATER.ORG

THE MARK CONSISTS OF STANDARD CHARACTERS WITHOUT CLAIM TO ANY PARTICULAR FONT, STYLE, SIZE, OR COLOR.

FOR CHARITABLE FUNDRAISING SERVICES, NAMELY, BY PROVIDING INDIVIDUALS WITH THE INFORMATION VIA INTERACTIVE COMPUTER DATABASE AND OPPORTUNITY TO MAKE MONETARY DONATIONS TO THEIR FAVORITE CHARITIES (U.S. CLS. 100, 101 AND 102).

FIRST USE 10-8-2010; IN COMMERCE 10-8-2010.

**CLASS 36—(Continued).**

3,942,234. PARKE BANCORP, INC., SEWELL, NJ. SN 85-057,417. PUB. 11-2-2010, FILED 6-8-2010.



THE MARK CONSISTS OF THE FANCIFUL CONFIGURATION OF A DOLLAR BILL WITH A FACE, LEGS, ARMS AND HANDS HOLDING A BAG WITH THE LETTERS "P" AND "B" ON THE BAG AND WITH THE IMAGE OF AN EAGLE ON THE DOLLAR BILL.

FOR BANKING SERVICES (U.S. CLS. 100, 101 AND 102).

FIRST USE 10-29-2010; IN COMMERCE 11-20-2010.

3,942,269. TEXAS LAWYERS' INSURANCE EXCHANGE, AUSTIN, TX. SN 85-071,151. PUB. 11-9-2010, FILED 6-24-2010.



NO CLAIM IS MADE TO THE EXCLUSIVE RIGHT TO USE "TEXAS LAWYERS' INSURANCE EXCHANGE" OR THE REPRESENTATION OF THE MAP OF TEXAS, APART FROM THE MARK AS SHOWN.

THE MARK CONSISTS OF THE WORDING "TLIE TEXAS LAWYERS' INSURANCE EXCHANGE EXPERIENCE WHEN YOU NEED IT MOST." IN STYLIZED FONT, SHOWN TO THE RIGHT OF AN INCOMPLETE OVAL CONTAINING A STYLIZED REPRESENTATION OF THE MAP OF TEXAS, WITH THE LOWER HALF OF THE STATE SHADED, WITH A SCALE OF JUSTICE HANGING FROM AN ARM OF THE SCALE, SUPERIMPOSED OVER THE MAP.

FOR UNDERWRITING AND ADMINISTRATION OF PROFESSIONAL LIABILITY INSURANCE FOR TEXAS LAWYERS AND JUDGES (U.S. CLS. 100, 101 AND 102).

FIRST USE 9-1-2010; IN COMMERCE 9-1-2010.



**CLASS 36—(Continued).**

3,942,276. RENERGY CAPITAL LLC, BARRINGTON HILLS, IL. SN 85-072,971. PUB. 11-30-2010, FILED 6-28-2010.

**RENERGY CAPITAL**

THE MARK CONSISTS OF STANDARD CHARACTERS WITHOUT CLAIM TO ANY PARTICULAR FONT, STYLE, SIZE, OR COLOR.

NO CLAIM IS MADE TO THE EXCLUSIVE RIGHT TO USE "CAPITAL", APART FROM THE MARK AS SHOWN.

FOR FINANCIAL SERVICES, NAMELY, INVESTMENT MANAGEMENT, INVESTMENT CONSULTATION, AND INVESTMENT OF FUNDS FOR OTHERS (U.S. CLS. 100, 101 AND 102).

FIRST USE 4-0-2009; IN COMMERCE 4-0-2009.

3,942,277. RENERGY CAPITAL LLC, BARRINGTON HILLS, IL. SN 85-072,983. PUB. 11-30-2010, FILED 6-28-2010.



NO CLAIM IS MADE TO THE EXCLUSIVE RIGHT TO USE "CAPITAL", APART FROM THE MARK AS SHOWN.

THE MARK CONSISTS OF THE WORD "RENERGY" APPEARING IN LARGER LETTERS ABOVE THE TERM "CAPITAL". THE "R" IN "RENERGY" IS CAPITALIZED WITH A TAIL SEPARATING THE TERMS "RENERGY" AND "CAPITAL". A CRESCENT SHAPE APPEARS ON THE UPPER-LEFT SIDE OF THE "R" WITH LINES RADIATING FROM THE CRESCENT SHAPE.

FOR FINANCIAL SERVICES, NAMELY, INVESTMENT MANAGEMENT, INVESTMENT CONSULTATION, AND INVESTMENT OF FUNDS FOR OTHERS (U.S. CLS. 100, 101 AND 102).

FIRST USE 4-0-2009; IN COMMERCE 4-0-2009.

3,942,287. OXFORD FINANCIAL SERVICES, ALEXANDRIA, VA. SN 85-075,633. PUB. 11-30-2010, FILED 7-1-2010.

**CAPITAL. FOR LIFE.**

THE MARK CONSISTS OF STANDARD CHARACTERS WITHOUT CLAIM TO ANY PARTICULAR FONT, STYLE, SIZE, OR COLOR.

**CLASS 36—(Continued).**

NO CLAIM IS MADE TO THE EXCLUSIVE RIGHT TO USE "CAPITAL", APART FROM THE MARK AS SHOWN.

FOR FINANCING SERVICES (U.S. CLS. 100, 101 AND 102).

FIRST USE 9-15-2010; IN COMMERCE 9-15-2010.

3,942,292. IFS FINANCIAL SERVICES, INC., CINCINNATI, OH. SN 85-079,428. PUB. 10-19-2010, FILED 7-7-2010.

**LEGACY FORWARD**

THE MARK CONSISTS OF STANDARD CHARACTERS WITHOUT CLAIM TO ANY PARTICULAR FONT, STYLE, SIZE, OR COLOR.

FOR INSURANCE SERVICES, NAMELY, UNDERWRITING, ISSUING AND ADMINISTRATION OF LIFE INSURANCE (U.S. CLS. 100, 101 AND 102).

FIRST USE 11-11-2010; IN COMMERCE 11-11-2010.

3,942,312. MCS FINANCIAL ADVISORS LLC, DBA MCS FINANCIAL ADVISORS, EUGENE, OR. SN 85-092,764. PUB. 11-23-2010, FILED 7-26-2010.

**Managing Risk to Increase  
Wealth**

THE MARK CONSISTS OF STANDARD CHARACTERS WITHOUT CLAIM TO ANY PARTICULAR FONT, STYLE, SIZE, OR COLOR.

FOR FINANCIAL ADVICE; FINANCIAL ADVICE AND CONSULTANCY SERVICES; FINANCIAL ADVISORY AND CONSULTANCY SERVICES; FINANCIAL PLANNING; FINANCIAL PLANNING AND INVESTMENT ADVISORY SERVICES; FINANCIAL RISK MANAGEMENT; FINANCIAL RISK MANAGEMENT CONSULTATION; FINANCIAL SERVICES, NAMELY, WEALTH MANAGEMENT SERVICES (U.S. CLS. 100, 101 AND 102).

FIRST USE 9-1-2010; IN COMMERCE 12-1-2010.

**CLASS 37—CONSTRUCTION AND REPAIR**

**CLASS 37—(Continued).**

3,941,002. HINTON, SR, ANTHONY, FREDERICKSBURG, VA. SN 76-701,935. PUB. 8-3-2010, FILED 3-5-2010.



THE COLOR(S) RED, WHITE AND BLUE IS/ARE CLAIMED AS A FEATURE OF THE MARK.

THE MARK CONSISTS OF A DESKTOP COMPUTER WITH A FEATHER DUSTER ON THE KEYBOARD. THE COMPUTER CONSIST OF A RED MONITOR WITH A WHITE SCREEN WITH BLUE OUTLINING THE SCREEN; A RED CPU WITH BLUE OUTLINING OF THE DETAILS ON THE CPU; A RED MOUSE WITH BLUE OUTLINING OF THE DETAILS ON THE MOUSE; A RED KEYBOARD WITH BLUE OUTLINING ON THE DETAILS IN THE KEYBOARD. THE FEATHER DUSTER IS WHITE WITH THE HANDLE OUTLINED IN BLUE AND THE FEATHERS OUTLINED IN RED; UNDER THE DUSTER IS A BLUE PLUME OF DUST.

FOR PHYSICAL COMPUTER CLEANING SERVICES (U.S. CLS. 100, 103 AND 106).

FIRST USE 11-15-2010; IN COMMERCE 11-15-2010.

3,941,040. ADVANCED FIRE SYSTEMS, INC., HOPKINTON, MA. SN 77-239,847. PUB. 10-28-2008, FILED 7-26-2007.

**ADVANCED FIRE SYSTEMS**

THE MARK CONSISTS OF STANDARD CHARACTERS WITHOUT CLAIM TO ANY PARTICULAR FONT, STYLE, SIZE, OR COLOR.

NO CLAIM IS MADE TO THE EXCLUSIVE RIGHT TO USE "FIRE SYSTEMS", APART FROM THE MARK AS SHOWN.

FOR FIRE PROTECTION SERVICES, NAMELY, INSTALLATION AND MAINTENANCE OF EQUIPMENT AND INSTALLATIONS FOR PROTECTION AGAINST FIRE (U.S. CLS. 100, 103 AND 106).

FIRST USE 5-0-2007; IN COMMERCE 4-1-2008.

**CLASS 37—(Continued).**

3,941,165. PULP STUDIO, INC., LOS ANGELES, CA. SN 77-615,231. PUB. 1-5-2010, FILED 11-15-2008.



THE COLOR(S) RED AND GREEN IS/ARE CLAIMED AS A FEATURE OF THE MARK.

THE MARK CONSISTS OF A RED SPIRAL DESIGN AND GREEN WORDING "PINTURA".

THE ENGLISH TRANSLATION OF "PINTURA" IN THE MARK IS PAINTING.

FOR APPLYING DECORATIVE COATINGS TO GLASS (U.S. CLS. 100, 103 AND 106).

FIRST USE 2-21-2011; IN COMMERCE 2-21-2011.

3,941,251. VAN ROMPAY, BOUD, CLEARWATER, FL. SN 77-710,355. PUB. 6-1-2010, FILED 4-9-2009.



OWNER OF U.S. REG. NO. 1,531,280.

THE COLOR(S) BLUE, BLACK AND WHITE IS/ARE CLAIMED AS A FEATURE OF THE MARK.

THE MARK CONSISTS OF THE WORD "HYDREX" WITH THREE DIMENSIONAL LETTERS AND SHADOWING. WAVE-LIKE RIPPLES APPEAR ACROSS THE BOTTOM HALF OF EACH LETTER. THE WAVES APPEAR IN BLUE WITH WHITE STRIPES. THE WORDING APPEARS IN WHITE WITH BLACK SHADOWING.

FOR MAINTENANCE AND PAINTING OF BOATS; UNDER-WATER CONSTRUCTION; UNDER-WATER REPAIR; UNDER-WATER PAINTING SERVICES; UNDER-WATER APPLICATION OF PROTECTIVE COATINGS (U.S. CLS. 100, 103 AND 106).

FIRST USE 4-0-1986; IN COMMERCE 9-22-1986.

3,941,269. CLOCKWORK IP, LLC, SARASOTA, FL. SN 77-733,802. PUB. 5-25-2010, FILED 5-11-2009.

**LIGHT SPEED ELECTRIC**

THE MARK CONSISTS OF STANDARD CHARACTERS WITHOUT CLAIM TO ANY PARTICULAR FONT, STYLE, SIZE, OR COLOR.

**CLASS 37—(Continued).**

NO CLAIM IS MADE TO THE EXCLUSIVE RIGHT TO USE "ELECTRIC", APART FROM THE MARK AS SHOWN.

FOR REPAIR, MAINTENANCE, REPLACEMENT AND INSTALLATION SERVICES IN THE FIELD OF ELECTRICAL WIRING, OUTLETS, LIGHT FIXTURES, AND ELECTRICAL PANELS; ELECTRICAL CONTRACTOR SERVICES; ELECTRICAL CONTRACTING SERVICES (U.S. CLS. 100, 103 AND 106).

FIRST USE 10-14-2010; IN COMMERCE 10-14-2010.

3,941,365. RIO PERLA PROPERTIES, L.P., SAN ANTONIO, TX. SN 77-783,101. PUB. 5-25-2010, FILED 7-16-2009.

GET YOUR FLAVOR ON

THE MARK CONSISTS OF STANDARD CHARACTERS WITHOUT CLAIM TO ANY PARTICULAR FONT, STYLE, SIZE, OR COLOR.

FOR REAL ESTATE DEVELOPMENT SERVICES FEATURING COMMERCIAL, RETAIL, ENTERTAINMENT, RESIDENTIAL AND MIXED USE; REAL ESTATE DEVELOPMENT SERVICES, NAMELY, PLANNING OF COMMERCIAL, RETAIL, ENTERTAINMENT, RESIDENTIAL AND MIXED USE COMMUNITIES (U.S. CLS. 100, 103 AND 106).

FIRST USE 11-30-2010; IN COMMERCE 11-30-2010.

3,941,367. RIO PERLA PROPERTIES, L.P., SAN ANTONIO, TX. SN 77-783,139. PUB. 5-25-2010, FILED 7-16-2009.

WHERE SAN ANTONIO GETS ITS  
FLAVOR

THE MARK CONSISTS OF STANDARD CHARACTERS WITHOUT CLAIM TO ANY PARTICULAR FONT, STYLE, SIZE, OR COLOR.

FOR REAL ESTATE DEVELOPMENT SERVICES FEATURING COMMERCIAL, RETAIL, ENTERTAINMENT, RESIDENTIAL AND MIXED USE; REAL ESTATE DEVELOPMENT SERVICES, NAMELY, PLANNING OF COMMERCIAL, RETAIL, ENTERTAINMENT, RESIDENTIAL AND MIXED USE COMMUNITIES (U.S. CLS. 100, 103 AND 106).

FIRST USE 11-30-2010; IN COMMERCE 11-30-2010.

**CLASS 37—(Continued).**

3,941,416. ORKIN EXPANSION, INC., WILMINGTON, DE. SN 77-802,060. PUB. 8-10-2010, FILED 8-11-2009.

ORKIN HEAT

THE MARK CONSISTS OF STANDARD CHARACTERS WITHOUT CLAIM TO ANY PARTICULAR FONT, STYLE, SIZE, OR COLOR.

OWNER OF U.S. REG. NOS. 568,404, 568,407, AND OTHERS.

NO CLAIM IS MADE TO THE EXCLUSIVE RIGHT TO USE "HEAT", APART FROM THE MARK AS SHOWN.

FOR PEST CONTROL SERVICES (U.S. CLS. 100, 103 AND 106).

FIRST USE 11-0-2009; IN COMMERCE 11-0-2009.

3,941,417. ORKIN EXPANSION, INC., WILMINGTON, DE. SN 77-802,115. PUB. 8-3-2010, FILED 8-11-2009.

ORKINHEAT

THE MARK CONSISTS OF STANDARD CHARACTERS WITHOUT CLAIM TO ANY PARTICULAR FONT, STYLE, SIZE, OR COLOR.

OWNER OF U.S. REG. NOS. 568,404, 568,407, AND OTHERS.

FOR PEST CONTROL SERVICES (U.S. CLS. 100, 103 AND 106).

FIRST USE 11-0-2009; IN COMMERCE 11-0-2009.

3,941,489. PRIMORIS ENERGY SOLUTIONS INC., NIWOT, CO. SN 77-843,452. PUB. 3-9-2010, FILED 10-7-2009.

CARHUGGER

THE MARK CONSISTS OF STANDARD CHARACTERS WITHOUT CLAIM TO ANY PARTICULAR FONT, STYLE, SIZE, OR COLOR.

FOR MECHANIC SERVICES; VEHICLE RETROFIT AND CONVERSION SERVICES; VEHICLE SERVICE STATIONS (U.S. CLS. 100, 103 AND 106).

FIRST USE 6-14-2009; IN COMMERCE 6-14-2009.

**CLASS 37—(Continued).**

3,941,858. SICURANZA, JOSEPH, EASTCHESTER, NY. SN 77-927,497. PUB. 6-15-2010, FILED 2-3-2010.

**SurgeonIT**

THE MARK CONSISTS OF STANDARD CHARACTERS WITHOUT CLAIM TO ANY PARTICULAR FONT, STYLE, SIZE, OR COLOR.

FOR INSTALLATION, MAINTENANCE AND REPAIR OF COMPUTER HARDWARE; REPAIR OR MAINTENANCE OF COMPUTERS (U.S. CLS. 100, 103 AND 106). FIRST USE 1-1-2011; IN COMMERCE 1-1-2011.

3,942,052. DIRECT ENERGY MARKETING LIMITED, TORONTO, ONTARIO, CANADA. SN 78-622,788. PUB. 10-9-2007, FILED 5-4-2005.



PRIORITY CLAIMED UNDER SEC. 44(D) ON CANADA APPLICATION NO. 1237034, FILED 11-12-2004.

FOR INSULATING DUCT AND FIREPLACE CLEANING; INSTALLATION AND REPAIR OF HOME APPLIANCES; HOME MAINTENANCE AND REPAIR SERVICES (U.S. CLS. 100, 103 AND 106).

FIRST USE 3-0-2003; IN COMMERCE 6-30-2010.

3,942,184. SEGO HOMES, LC, LINDON, UT. SN 85-046,583. PUB. 10-26-2010, FILED 5-24-2010.

**SEGO HOMES**

THE MARK CONSISTS OF STANDARD CHARACTERS WITHOUT CLAIM TO ANY PARTICULAR FONT, STYLE, SIZE, OR COLOR.

NO CLAIM IS MADE TO THE EXCLUSIVE RIGHT TO USE "HOMES", APART FROM THE MARK AS SHOWN.

FOR CONSTRUCTION OF RESIDENTIAL STRUCTURES AND HOMES; GENERAL CONSTRUCTION CONTRACTING (U.S. CLS. 100, 103 AND 106).

FIRST USE 1-28-2011; IN COMMERCE 1-28-2011.

**CLASS 38—COMMUNICATION**

**CLASS 38—(Continued).**

3,940,981. PUSHKIN, KENNETH, SANTA FE, NM. SN 76-673,042. PUB. 8-7-2007, FILED 2-21-2007.

**radiofreeamerica**

OWNER OF U.S. REG. NOS. 1,288,272 AND 3,161,707.

THE STYLIZED WORDS "RADIO FREE AMERICA" IN LOWER CASE LETTERS WITH THE FINAL "I" IN LARGER OFFSET PRINT

FOR AUDIO AND VIDEO BROADCASTING OF MUSICAL AND VIDEO PERFORMANCES VIA A GLOBAL COMPUTER NETWORK AND AUDIO AND VIDEO STREAMING OF LIVE AND RECORDED AUDIO AND VIDEO PERFORMANCES OF OTHERS VIA A GLOBAL COMPUTER NETWORK; PROVIDING ON-LINE CHAT ROOMS AND ELECTRONIC BULLETIN BOARDS FOR TRANSMISSION OF MESSAGES AMONG USERS IN THE FIELD OF GENERAL INTEREST (U.S. CLS. 100, 101 AND 104).

FIRST USE 1-15-2009; IN COMMERCE 1-15-2009.

3,941,175. PANTEL VENTURES LIMITED, PROVIDENCIALES, TURKS/CAICOS IS.. SN 77-633,515. PUB. 7-21-2009, FILED 12-15-2008.



THE MARK CONSISTS OF A CIRCLE POSITIONED INSIDE OF A PARTIAL SQUARE.

FOR VIDEO-ON-DEMAND TRANSMISSION SERVICES; AUDIO-ON-DEMAND TRANSMISSION SERVICES; STREAMING OF AUDIO AND VIDEO MATERIAL ON THE INTERNET; BROADCASTING IN THE FIELD OF AUDIO, RADIO, VIDEO, MOTION PICTURE AND TELEVISION; BROADCASTING OF TELEVISION, VIDEO AND AUDIO PROGRAMMING VIA SATELLITE, THE INTERNET AND CABLE; VIDEO BROADCASTING; PAY PER VIEW TELEVISION AND VIDEO TRANSMISSION SERVICES; AUDIO AND VIDEO BROADCAST TRANSMISSION OVER A GLOBAL COMPUTER NETWORK (U.S. CLS. 100, 101 AND 104).

FIRST USE 11-12-2010; IN COMMERCE 11-12-2010.

**CLASS 38—(Continued).**

3,941,176. PANTEL VENTURES LIMITED, PROVIDENCIALES, TURKS/CAICOS IS.. SN 77-633,529. PUB. 7-21-2009, FILED 12-15-2008.

**CLASS 38—(Continued).**

3,941,177. PANTEL VENTURES LIMITED, PROVIDENCIALES, TURKS/CAICOS IS.. SN 77-633,537. PUB. 7-21-2009, FILED 12-15-2008.



THE MARK CONSISTS OF A SERIES OF CURVED LINES FORMING TWO MISCELLANEOUS SHAPED AND CONNECTED SQUARES.

FOR VIDEO-ON-DEMAND TRANSMISSION SERVICES; AUDIO-ON-DEMAND TRANSMISSION SERVICES; STREAMING OF AUDIO AND VIDEO MATERIAL ON THE INTERNET; BROADCASTING IN THE FIELD OF AUDIO, RADIO, VIDEO, MOTION PICTURE AND TELEVISION; BROADCASTING OF TELEVISION, VIDEO AND AUDIO PROGRAMMING VIA SATELLITE, THE INTERNET AND CABLE; VIDEO BROADCASTING; PAY PER VIEW TELEVISION AND VIDEO TRANSMISSION SERVICES; AUDIO AND VIDEO BROADCAST TRANSMISSION OVER A GLOBAL COMPUTER NETWORK (U.S. CLS. 100, 101 AND 104).  
FIRST USE 11-12-2010; IN COMMERCE 11-12-2010.



THE MARK CONSISTS OF THREE ADJACENT DIAGONAL LINES WITH ROUNDED SIDES, WITH THE FIRST LINE BEING THE LONGEST AND THE OTHER TWO SHORTER LINES ARE THE SAME SIZE.

FOR VIDEO-ON-DEMAND TRANSMISSION SERVICES; AUDIO-ON-DEMAND TRANSMISSION SERVICES; STREAMING OF AUDIO AND VIDEO MATERIAL ON THE INTERNET; BROADCASTING IN THE FIELD OF AUDIO, RADIO, VIDEO, MOTION PICTURE AND TELEVISION; BROADCASTING OF TELEVISION, VIDEO AND AUDIO PROGRAMMING VIA SATELLITE, THE INTERNET AND CABLE; VIDEO BROADCASTING; PAY PER VIEW TELEVISION AND VIDEO TRANSMISSION SERVICES; AUDIO AND VIDEO BROADCAST TRANSMISSION OVER A GLOBAL COMPUTER NETWORK (U.S. CLS. 100, 101 AND 104).  
FIRST USE 11-12-2010; IN COMMERCE 11-12-2010.

3,941,342. WHITTLEWALLA, LLC, BELLEVUE, WA. SN 77-773,124. PUB. 12-1-2009, FILED 7-2-2009.

# Whittlewalla

THE MARK CONSISTS OF STANDARD CHARACTERS WITHOUT CLAIM TO ANY PARTICULAR FONT, STYLE, SIZE, OR COLOR.

FOR PROVIDING ON-LINE FORUMS FOR TRANSMISSION OF MESSAGES AMONG COMPUTER USERS CONCERNING FINANCIAL ISSUES AND SAVING MONEY (U.S. CLS. 100, 101 AND 104).  
FIRST USE 12-20-2010; IN COMMERCE 1-22-2011.

**CLASS 38—(Continued).**

3,941,439. TCT MINISTRIES, INC., MARION, IL. SN 77-812,012. PUB. 6-1-2010, FILED 8-25-2009.



OWNER OF U.S. REG. NOS. 3,487,703 AND 3,491,714. NO CLAIM IS MADE TO THE EXCLUSIVE RIGHT TO USE "KIDS", APART FROM THE MARK AS SHOWN.

THE COLOR(S) SILVER, RED, YELLOW, BLUE, GREEN, WHITE AND BLACK IS/ARE CLAIMED AS A FEATURE OF THE MARK.

THE MARK CONSISTS OF THE STYLIZED WORD "TCT" WITH TWO HORIZONTAL ACCENT LINES, ONE IMMEDIATELY ABOVE AND ONE IMMEDIATELY BENEATH, WITH THE STYLED WORD "KIDS" OVERLAYED OVER THE BOTTOM ONE FIFTH OF "TCT". THE "K" IS FILLED WITH VARIOUS DEPICTIONS OF CHILDREN. THE ACCENT LINES AND WORDING "TCT" ARE SILVER WITH BLUE LINING ON THE TOP AND BLACK HIGHLIGHTING. THE "K" IS RED WITH THE CHILDREN DEPICTED IN WHITE. THE "I" IS YELLOW, "D" IS BLUE, AND "S" IS GREEN.

FOR TELEVISION BROADCASTING; VIDEO BROADCASTING SERVICES VIA THE INTERNET (U.S. CLS. 100, 101 AND 104).

FIRST USE 5-15-2009; IN COMMERCE 5-15-2009.

3,941,555. DISH NETWORK, L.L.C., ENGLEWOOD, CO. SN 77-872,003. PUB. 4-20-2010, FILED 11-13-2009.

**MIDNIGHT LOUNGE**

THE MARK CONSISTS OF STANDARD CHARACTERS WITHOUT CLAIM TO ANY PARTICULAR FONT, STYLE, SIZE, OR COLOR.

FOR TELECOMMUNICATION SERVICES, NAMELY, TRANSMISSION OF VIDEO, IMAGE, VOICE, AUDIO, AND DATA INFORMATION VIA TELEVISION, SATELLITE, CABLE, WIRELESS, FIBER OPTICS, AND GLOBAL COMMUNICATION NETWORKS; TRANSMISSION OF TELEVISION BROADCASTING SERVICES VIA SATELLITE; VIDEO-ON-DEMAND AND PAY-PER-VIEW TELEVISION TRANSMISSION SERVICES; TELEVISION TRANSMISSION SERVICES; BROADCASTING OF TELEVISION PROGRAMS (U.S. CLS. 100, 101 AND 104).

FIRST USE 12-31-2009; IN COMMERCE 12-31-2009.

**CLASS 38—(Continued).**

3,941,718. TELINTEL, WESTON, FL. SN 77-904,465. PUB. 5-18-2010, FILED 1-4-2010.

**Siptunu**

THE MARK CONSISTS OF STANDARD CHARACTERS WITHOUT CLAIM TO ANY PARTICULAR FONT, STYLE, SIZE, OR COLOR.

FOR COMMUNICATIONS VIA MULTINATIONAL TELECOMMUNICATION NETWORKS; TELECOMMUNICATION SERVICES IN THE NATURE OF PROVIDING TELEPHONE SERVICES WITH VARIOUS TELEPHONE FEATURES, NAMELY, A DEDICATED TOLL-FREE NUMBER, VOICEMAIL, MULTIPLE MAILBOX EXTENSIONS, TELEPHONE MESSAGE NOTIFICATION, FAX CAPABILITIES, DETAILED CALL REPORTS, CALL WAITING, CALL IDENTIFICATION, CALL FORWARDING, AND MESSAGE WAITING; TELECOMMUNICATION SERVICES, NAMELY, LOCAL AND LONG DISTANCE TRANSMISSION OF VOICE, DATA, GRAPHICS AND VIDEO BY MEANS OF BROADBAND, COPPER AND OPTICAL OR WIRELESS NETWORKS; TELECOMMUNICATION SERVICES, NAMELY, LOCAL AND LONG DISTANCE TRANSMISSION OF VOICE, DATA, GRAPHICS BY MEANS OF TELEPHONE, TELEGRAPHIC, CABLE, AND SATELLITE TRANSMISSIONS; TELECOMMUNICATION SERVICES, NAMELY, PROVIDING ADVANCED CALLING FEATURES, NAMELY, PROVIDING AN INTERNATIONAL CALLING FUNCTION TO EASILY PLACE INTERNATIONAL CALLS (U.S. CLS. 100, 101 AND 104).

FIRST USE 9-22-2009; IN COMMERCE 9-30-2009.

3,941,731. PANAMEDIA GROUP, LLC, ST. LOUIS, MO. SN 77-907,572. PUB. 6-15-2010, FILED 1-8-2010.

**BUSYEVENT**

THE MARK CONSISTS OF STANDARD CHARACTERS WITHOUT CLAIM TO ANY PARTICULAR FONT, STYLE, SIZE, OR COLOR.

FOR TELECOMMUNICATION SERVICES, NAMELY, PROVIDING ACCESS TO A WIRELESS LOCAL AREA NETWORK FOR USE BY EVENT ATTENDEES, VENDORS AND ORGANIZERS FOR MANAGING THE FLOW OF EVENT-SPECIFIC ELECTRONIC INFORMATION, NAMELY, BROCHURES, BUSINESS CARDS, COURSE MATERIALS, SPEAKER NOTES, SESSION ATTENDANCE TRACKING AND SURVEYS, AND FOR FACILITATING EFFECTIVE COMMUNICATION AMONG EVENT ATTENDEES, VENDORS AND ORGANIZERS DURING AND AFTER AN EVENT (U.S. CLS. 100, 101 AND 104).

FIRST USE 4-28-2009; IN COMMERCE 4-28-2009.

**CLASS 38—(Continued).**

3,941,749. FEDTECHSERVICES,LLC, AKA FTS, TAMPA, FL. SN 77-911,133. PUB. 5-11-2010, FILED 1-13-2010.



NO CLAIM IS MADE TO THE EXCLUSIVE RIGHT TO USE "FTS" AND "SERVICES, LLC", APART FROM THE MARK AS SHOWN.

THE COLOR(S) MEDIUM GRAY, MEDIUM BLUE, LIGHT BLUE, AND WHITE IS/ARE CLAIMED AS A FEATURE OF THE MARK.

THE MARK CONSIST OF THE LETTERS "FTS" IN WHITE ON A MEDIUM BLUE SPHERE WITH LIGHT BLUE BANDING IN THE CENTER AND LIGHT BLUE HIGHLIGHTS AND A LIGHT BLUE SHADOW; A MEDIUM GREY CURVING BAND SPLIT BY THE SPHERE; THE WORDING "FEDTECH" WITH THE LETTERS "FED" IN MEDIUM GREY AND THE LETTERS "TECH" IN MEDIUM BLUE; AND THE MEDIUM GREY WORDING "SERVICES, LLC".

FOR TELECOMMUNICATIONS CONSULTATION (U.S. CLS. 100, 101 AND 104).

FIRST USE 1-13-2010; IN COMMERCE 1-13-2010.

**CLASS 38—(Continued).**

3,941,893. TELFONI, INC., SAFAT, KUWAIT. SN 77-933,304. PUB. 7-27-2010, FILED 2-11-2010.



THE COLOR(S) BLUE, WHITE, YELLOW, BLACK, GREEN IS/ARE CLAIMED AS A FEATURE OF THE MARK. THE MARK CONSISTS OF THE FOLLOWING: THE WORDS "TELFONI MY WAY 2 COMMUNICATE" AND VARIOUS SIZE CIRCLES. THE WORD "TELFONI" IS IN WHITE COLOR, THE WORD "MY WAY COMMUNICATE" IS IN WHITE COLOR. THE NUMERAL "2" IS IN YELLOW COLOR. THE VARIOUS SIZE CIRCLES ARE IN BLUE, GREEN, WHITE, YELLOW AND BLACK.

FOR COMPUTER TELEPHONY SERVICES; INTERNET TELEPHONY SERVICES; MOBILE TELEPHONY; TELEPHONY COMMUNICATION SERVICES; VOICE OVER INTERNET PROTOCOL (VOIP) SERVICES (U.S. CLS. 100, 101 AND 104).

FIRST USE 9-22-2010; IN COMMERCE 9-22-2010.

3,941,851. AVILES, MIRANDA L., KATY, TX. SN 77-926,349. PUB. 6-15-2010, FILED 2-2-2010.



THE COLOR(S) BLUE, WHITE, BLACK, YELLOW, GREEN AND BROWN IS/ARE CLAIMED AS A FEATURE OF THE MARK.

THE MARK CONSISTS OF A BLACK, RECTANGULAR-SHAPED BACKGROUND CONTAINING THE LETTERS "ADBS" IN BLOCK-STYLED FONT, EACH LETTER BEING FORMED BY SEGMENTS OF VARIOUS SHAPES AND SIZES WHICH ARE EACH OUTLINED IN WHITE. THE INTERIOR PORTION OF EACH LETTER DEPICTS AN ABSTRACT WORLD MAP PROJECTION HAVING OCEANS DEPICTED IN BLUE, CLOUDS DEPICTED IN WHITE AND CONTINENTS DEPICTED IN YELLOW, GREEN AND BROWN. IN ADDITION, THE LETTER "A" AND THE LEFT PORTION OF THE LETTER "D" INCLUDE WHITE, TRANSPARENT, TILE-SHAPED FIGURES THAT ARE PLACED RANDOMLY WITHIN THE TWO LETTERS.

FOR TELEVISION BROADCASTING SERVICES (U.S. CLS. 100, 101 AND 104).

FIRST USE 1-0-2011; IN COMMERCE 1-0-2011.

3,942,278. WIRELESSBEEHIVE.COM LLC, DBA BEEHIVE BROADBAND, LAKE POINT, UT. SN 85-073,277. PUB. 11-9-2010, FILED 6-28-2010.

**BEEHIVE DIGITAL VOICE**

THE MARK CONSISTS OF STANDARD CHARACTERS WITHOUT CLAIM TO ANY PARTICULAR FONT, STYLE, SIZE, OR COLOR.

NO CLAIM IS MADE TO THE EXCLUSIVE RIGHT TO USE "DIGITAL VOICE", APART FROM THE MARK AS SHOWN.

FOR VOICE OVER INTERNET PROTOCOL TELEPHONE SERVICES (U.S. CLS. 100, 101 AND 104).

FIRST USE 1-21-2011; IN COMMERCE 1-21-2011.

**CLASS 39—TRANSPORTATION AND STORAGE**

**CLASS 39—(Continued).**

3,941,021. NATIONAL PSORIASIS FOUNDATION, PORTLAND, OR. SN 77-122,623. PUB. 4-29-2008, FILED 3-5-2007.



OWNER OF U.S. REG. NOS. 1,674,028 AND 2,908,232.  
NO CLAIM IS MADE TO THE EXCLUSIVE RIGHT TO USE "PSORIASIS" AND "BIOBANK", APART FROM THE MARK AS SHOWN.

THE NAME "VICTOR HENSCHEL" IN THE MARK DOES NOT IDENTIFY A LIVING INDIVIDUAL.

THE MARK CONSISTS OF A STYLIZED REPRESENTATION OF PEOPLE ARRANGED IN A CIRCLE WITH A VERTICALLY ORIENTED DOUBLE HELIX. TO THE RIGHT OF THE DESIGN ARE THE WORDS "NATIONAL PSORIASIS VICTOR HENSCHEL BIOBANK".

SEC. 2(F) AS TO "NATIONAL".

FOR COLLECTION AND STORAGE OF BIOLOGICAL SAMPLES AND CLINICAL INFORMATION CONCERNING INDIVIDUALS WHO PROVIDE THE SAMPLES FOR USE IN THE FIELD OF PSORIASIS GENETICS AND PSORIASIS RESEARCH; PROVIDING ACCESS TO BIOLOGICAL SAMPLES AND CLINICAL INFORMATION TO INDEPENDENT RESEARCHERS IN THE FIELDS OF PSORIASIS GENETIC RESEARCH, RESEARCH INTO TREATMENTS FOR PSORIASIS AND POSSIBLE CURES FOR PSORIASIS (U.S. CLS. 100 AND 105).  
FIRST USE 9-1-2010; IN COMMERCE 9-1-2010.

**CLASS 39—(Continued).**

3,941,543. ANOTHER ATTIC, LTD., AMARILLO, TX. SN 77-867,745. PUB. 6-22-2010, FILED 11-8-2009.



OWNER OF U.S. REG. NO. 2,143,221.

NO CLAIM IS MADE TO THE EXCLUSIVE RIGHT TO USE "SELF-STORAGE", APART FROM THE MARK AS SHOWN.

THE MARK CONSISTS OF AN ILLUSTRATION OF A CHIPMUNK CARRYING A CARDBOARD MOVING BOX THAT IS OPEN AT THE TOP AND OVERFLOWING WITH ACORNS. ON THE BOX IS THE WORDING "ANOTHER ATTIC SELF-STORAGE" WITH THE DESIGN OF A BOX AND ROCKING CHAIR.

FOR MINI-WAREHOUSE STORAGE SERVICES (U.S. CLS. 100 AND 105).

FIRST USE 11-1-2008; IN COMMERCE 11-1-2008.

3,941,270. TUTKA, LLC, WASILLA, AK. SN 77-735,374. PUB. 5-25-2010, FILED 5-12-2009.

# TUTKA

THE MARK CONSISTS OF STANDARD CHARACTERS WITHOUT CLAIM TO ANY PARTICULAR FONT, STYLE, SIZE, OR COLOR.

THE ENGLISH TRANSLATION OF "TUTKA" IN THE MARK IS "RADAR".

FOR WASTE TRANSPORTATION FOR OTHERS (U.S. CLS. 100 AND 105).

FIRST USE 5-0-2007; IN COMMERCE 5-0-2007.

3,941,726. KOKI ENTERPRISES, LLC, KIHEI, HI. SN 77-906,539. PUB. 6-1-2010, FILED 1-6-2010.

# TURTLE TOWN

THE MARK CONSISTS OF STANDARD CHARACTERS WITHOUT CLAIM TO ANY PARTICULAR FONT, STYLE, SIZE, OR COLOR.

FOR ARRANGING AND CONDUCTING SCUBA DIVING AND SNORKELING TOURS (U.S. CLS. 100 AND 105).

FIRST USE 9-24-2009; IN COMMERCE 9-24-2009.



**CLASS 39—(Continued).**

3,942,157. MASON PROPANE SERVICE LLC, EAST BERLIN, PA. SN 85-039,357. PUB. 10-12-2010, FILED 5-14-2010.



THE STIPPLING IS FOR SHADING PURPOSES. THE MARK CONSISTS OF A GAS FLAME DESIGN THAT HAS BEEN PERSONIFIED WITH EYES, A MOUTH, FEET AND LEGS. FOR DELIVERY OF PROPANE (U.S. CLS. 100 AND 105). FIRST USE 1-1-2010; IN COMMERCE 10-1-2010.

3,942,290. RELIANT ENERGY RETAIL HOLDINGS, LLC, HOUSTON, TX. SN 85-078,528. PUB. 10-26-2010, FILED 7-6-2010.

**Cap-and-Save**

THE MARK CONSISTS OF STANDARD CHARACTERS WITHOUT CLAIM TO ANY PARTICULAR FONT, STYLE, SIZE, OR COLOR. FOR DISTRIBUTION OF ELECTRICITY, THE PRICING OF WHICH INCLUDES AN ADJUSTABLE PRICE WITH A DEFINED MAXIMUM RATE (U.S. CLS. 100 AND 105). FIRST USE 8-30-2010; IN COMMERCE 8-30-2010.

**CLASS 39—(Continued).**

3,942,297. THE SUBURBAN BUS DIVISION OF THE REGIONAL TRANSPORTATION AUTHORITY, DBA PACE, ARLINGTON HEIGHTS, IL. SN 85-080,650. PUB. 12-7-2010, FILED 7-8-2010.

**Connecting Communities**

THE MARK CONSISTS OF STANDARD CHARACTERS WITHOUT CLAIM TO ANY PARTICULAR FONT, STYLE, SIZE, OR COLOR. FOR MASS TRANSIT SERVICES FOR THE GENERAL PUBLIC (U.S. CLS. 100 AND 105). FIRST USE 12-1-2010; IN COMMERCE 12-1-2010.

**CLASS 40—MATERIAL TREATMENT**

3,941,011. HI-TECH WELDING AND FORMING, INC., EL CAJON, CA. SN 77-027,563. PUB. 11-6-2007, FILED 10-23-2006.

**2ND GENERATION**

THE MARK CONSISTS OF STANDARD CHARACTERS WITHOUT CLAIM TO ANY PARTICULAR FONT, STYLE, SIZE, OR COLOR. FOR CUSTOM TITANIUM, TITANIUM ALLOYS, INCONEL AND ALUMINUM COMPONENT FABRICATION OF COMPLEX MISSION CRITICAL FORMED STRUCTURES FOR MULTIPART FABRICATIONS TO THE ORDER AND SPECIFICATION OF OTHERS, IN THE FIELDS OF THE COMMERCIAL, INDUSTRIAL, MILITARY, AEROSPACE AND TRANSPORTATION INDUSTRIES (U.S. CLS. 100, 103 AND 106). FIRST USE 1-14-2011; IN COMMERCE 1-14-2011.

3,941,012. HI-TECH WELDING AND FORMING, INC., EL CAJON, CA. SN 77-027,568. PUB. 11-6-2007, FILED 10-23-2006.

**2ND GENERATION SPF**

THE MARK CONSISTS OF STANDARD CHARACTERS WITHOUT CLAIM TO ANY PARTICULAR FONT, STYLE, SIZE, OR COLOR.

**CLASS 40—(Continued).**

NO CLAIM IS MADE TO THE EXCLUSIVE RIGHT TO USE "SPF", APART FROM THE MARK AS SHOWN.

FOR CUSTOM TITANIUM, TITANIUM ALLOYS, INCONEL AND ALUMINUM COMPONENT FABRICATION OF COMPLEX MISSION CRITICAL FORMED STRUCTURES FOR MULTIPART FABRICATIONS TO THE ORDER AND SPECIFICATION OF OTHERS, IN THE FIELDS OF THE COMMERCIAL, INDUSTRIAL, MILITARY, AEROSPACE AND TRANSPORTATION INDUSTRIES (U.S. CLS. 100, 103 AND 106).

FIRST USE 1-14-2011; IN COMMERCE 1-14-2011.

---

3,941,264. ENTERTAINMENT BEVERAGES DISTILLERS, LLC, NORWOOD, MA. SN 77-725,596. PUB. 3-30-2010, FILED 4-29-2009.

**ENTERTAINMENT BEVERAGES**

THE MARK CONSISTS OF STANDARD CHARACTERS WITHOUT CLAIM TO ANY PARTICULAR FONT, STYLE, SIZE, OR COLOR.

NO CLAIM IS MADE TO THE EXCLUSIVE RIGHT TO USE "BEVERAGES", APART FROM THE MARK AS SHOWN.

FOR MANUFACTURING SERVICES FOR OTHERS IN THE FIELD OF NON-ALCOHOLIC BEVERAGES; MANUFACTURING SERVICES FOR OTHERS IN THE FIELD OF ALCOHOLIC BEVERAGES; CUSTOM MANUFACTURING OF NON-ALCOHOLIC BEVERAGES; CUSTOM MANUFACTURING OF ALCOHOLIC BEVERAGES; PRIVATE LABEL MANUFACTURING SERVICES IN THE FIELD OF NON-ALCOHOLIC BEVERAGES; PRIVATE LABEL MANUFACTURING SERVICES IN THE FIELD OF ALCOHOLIC BEVERAGES (U.S. CLS. 100, 103 AND 106).

FIRST USE 6-30-2006; IN COMMERCE 3-24-2009.

---

3,941,316. ST. JOHN'S MEDICAL RESEARCH INSTITUTE, INC., SPRINGFIELD, MO. SN 77-763,874. PUB. 6-8-2010, FILED 6-19-2009.

**INVENO**

THE MARK CONSISTS OF STANDARD CHARACTERS WITHOUT CLAIM TO ANY PARTICULAR FONT, STYLE, SIZE, OR COLOR.

FOR CUSTOM MANUFACTURING OF PRODUCTS FOR OTHERS IN THE FIELD OF MEDICAL PRODUCTS, MEDICAL DEVICES AND PHARMACEUTICALS (U.S. CLS. 100, 103 AND 106).

FIRST USE 9-16-2009; IN COMMERCE 9-16-2009.

**CLASS 40—(Continued).**

3,941,407. JEREMY COWAN, SAN FRANCISCO, CA. SN 77-799,367. PUB. 1-12-2010, FILED 8-7-2009.

**CONEY ISLAND**

THE MARK CONSISTS OF STANDARD CHARACTERS WITHOUT CLAIM TO ANY PARTICULAR FONT, STYLE, SIZE, OR COLOR.

OWNER OF U.S. REG. NOS. 3,656,914 AND 3,685,131. SEC. 2(F).

FOR BREWERY SERVICES (U.S. CLS. 100, 103 AND 106).

FIRST USE 5-0-2010; IN COMMERCE 5-0-2010.

---

3,941,992. TRS QUALITY, INC., FORT WORTH, TX. SN 77-964,971. PUB. 7-13-2010, FILED 3-22-2010.

**The Shack Battery Recycling Program**

THE MARK CONSISTS OF STANDARD CHARACTERS WITHOUT CLAIM TO ANY PARTICULAR FONT, STYLE, SIZE, OR COLOR.

OWNER OF U.S. REG. NOS. 1,720,904, 1,981,542, AND 2,519,389.

NO CLAIM IS MADE TO THE EXCLUSIVE RIGHT TO USE "BATTERY RECYCLING PROGRAM", APART FROM THE MARK AS SHOWN.

FOR RECYCLING PROGRAMS FOR BATTERIES (U.S. CLS. 100, 103 AND 106).

FIRST USE 3-1-2010; IN COMMERCE 3-1-2010.

---

3,942,108. TRS QUALITY, INC., FORT WORTH, TX. SN 85-014,735. PUB. 7-20-2010, FILED 4-15-2010.



OWNER OF U.S. REG. NOS. 1,720,904, 1,981,542, AND 2,519,389.

**CLASS 40—(Continued).**

NO CLAIM IS MADE TO THE EXCLUSIVE RIGHT TO USE "BATTERY RECYCLING PROGRAM", APART FROM THE MARK AS SHOWN.

THE COLOR(S) BLACK, GREY, AND WHITE IS/ARE CLAIMED AS A FEATURE OF THE MARK.

THE MARK CONSISTS OF BLACK CIRCLE WITH THE WORDING "THE SHACK BATTERY RECYCLING PROGRAM" WRITTEN IN GREY AND WHITE ON THE INSIDE OF THE CIRCLE; AROUND THE CIRCLE ARE THREE GREY ARROWS FORMING THE RECYCLING SYMBOL.

FOR RECYCLING PROGRAMS FOR BATTERIES (U.S. CLS. 100, 103 AND 106).

FIRST USE 3-1-2010; IN COMMERCE 3-1-2010.

**CLASS 41—EDUCATION AND ENTERTAINMENT**

3,940,980. JOHNSON & JOHNSON, NEW BRUNSWICK, NJ. SN 76-671,448. PUB. 2-5-2008, FILED 1-16-2007.

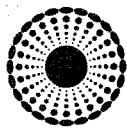

**THE VISION CARE  
INSTITUTE, LLC**

a *Johnson & Johnson* company

OWNER OF U.S. REG. NO. 3,075,294.

NO CLAIM IS MADE TO THE EXCLUSIVE RIGHT TO USE "VISION CARE INSTITUTE, LLC" AND "COMPANY", APART FROM THE MARK AS SHOWN.

FOR EDUCATIONAL SERVICES, NAMELY, CONDUCTING CLASSES, SEMINARS, FOCUS GROUPS, WORKSHOPS AND CONFERENCES, TO HELP PREPARE AND TRAIN STUDENTS FOR THEIR CAREERS AS EYE CARE PROFESSIONALS AND THE DISTRIBUTION OF PRINTED COURSE MATERIALS THEREWITH (U.S. CLS. 100, 101 AND 107).

FIRST USE 3-10-2004; IN COMMERCE 3-10-2004.

3,941,008. JOHNSON PUBLISHING COMPANY, INC., CHICAGO, IL. SN 77-000,663. PUB. 5-8-2007, FILED 9-15-2006.

**TASTE OF EBONY**

THE MARK CONSISTS OF STANDARD CHARACTERS WITHOUT CLAIM TO ANY PARTICULAR FONT, STYLE, SIZE, OR COLOR.

OWNER OF U.S. REG. NOS. 423,815, 1,536,329, AND OTHERS.

FOR PROVISION OF INSTRUCTIONAL SEMINARS, FOOD PREPARATION DEMONSTRATIONS AND EXPOSITIONS IN THE CULINARY FIELD FOR EDUCATIONAL AND ENTERTAINMENT PURPOSES (U.S. CLS. 100, 101 AND 107).

FIRST USE 10-23-2006; IN COMMERCE 10-23-2006.

**CLASS 41—(Continued).**

3,941,038. FREE RADT, DENVER, CO. SN 77-231,866. PUB. 7-6-2010, FILED 7-17-2007.

**Free Radt**

THE MARK CONSISTS OF STANDARD CHARACTERS WITHOUT CLAIM TO ANY PARTICULAR FONT, STYLE, SIZE, OR COLOR.

FOR ENTERTAINMENT, NAMELY, LIVE PERFORMANCES OF A MUSICAL BAND (U.S. CLS. 100, 101 AND 107).

FIRST USE 1-1-2007; IN COMMERCE 1-1-2007.

3,941,046. WORLD WRESTLING ENTERTAINMENT, INC., STAMFORD, CT. SN 77-286,747. PUB. 3-11-2008, FILED 9-24-2007.

**NATURE BOY**

THE MARK CONSISTS OF STANDARD CHARACTERS WITHOUT CLAIM TO ANY PARTICULAR FONT, STYLE, SIZE, OR COLOR.

FOR ENTERTAINMENT SERVICES, NAMELY, WRESTLING EXHIBITIONS AND PERFORMANCES BY A PROFESSIONAL WRESTLER AND ENTERTAINER; PROVIDING WRESTLING NEWS AND INFORMATION VIA A GLOBAL COMPUTER NETWORK (U.S. CLS. 100, 101 AND 107).

FIRST USE 1-1-1976; IN COMMERCE 1-1-1976.

3,941,054. ROCKY MOUNTAIN TENNIS CLUBS, LLC, BOULDER, CO. SN 77-327,569. PUB. 10-14-2008, FILED 11-12-2007.

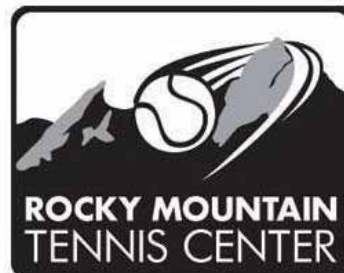

NO CLAIM IS MADE TO THE EXCLUSIVE RIGHT TO USE "ROCKY MOUNTAIN TENNIS CENTER", APART FROM THE MARK AS SHOWN.

**CLASS 41—(Continued).**

THE MARK CONSISTS OF A TENNIS BALL ENCIRCLING AND COMING OUT OF THE SNOW-CAPPED ROCKY MOUNTAINS. BELOW THE TENNIS BALL IS THE WORDING "ROCKY MOUNTAIN TENNIS CENTER".

FOR PROVIDING FITNESS AND EXERCISE FACILITIES (U.S. CLS. 100, 101 AND 107).

FIRST USE 9-0-2008; IN COMMERCE 9-0-2008.

---

3,941,081. SCOTT, GINI GRAHAM, DBA CREATIVE COMMUNICATIONS & RESEARCH, OAKLAND, CA. SN 77-455,323. PUB. 11-18-2008, FILED 4-22-2008.

DO YOU LOOK LIKE YOUR  
DOG?

THE MARK CONSISTS OF STANDARD CHARACTERS WITHOUT CLAIM TO ANY PARTICULAR FONT, STYLE, SIZE, OR COLOR.

FOR VIDEOTAPE PRODUCTION; ENTERTAINMENT IN THE NATURE OF COMPETITIONS, CONTESTS, AND PRODUCTION AND DISTRIBUTION OF GAME SHOWS IN THE FIELDS OF DOGS AND PETS; ENTERTAINMENT IN THE NATURE OF ON-GOING TELEVISION PROGRAMS IN THE FIELDS OF VARIETY AND COMEDY; PRODUCTION AND DISTRIBUTION OF FILMS IN THE ENTERTAINMENT FIELDS OF VARIETY AND COMEDY; ENTERTAINMENT SERVICES, NAMELY, CONDUCTING ENTERTAINMENT EXHIBITIONS IN THE NATURE OF FASHION SHOWS; ORGANIZING COMMUNITY FESTIVALS FEATURING A VARIETY OF ACTIVITIES, NAMELY, CONTESTS, GAMES, LIVE VARIETY SHOWS, PET SHOWS, DOG SHOWS, ANIMAL SHOWS; ORGANIZATION OF FASHION SHOWS (U.S. CLS. 100, 101 AND 107).

FIRST USE 10-20-2010; IN COMMERCE 10-20-2010.

---

3,941,082. LIS, PAUL, FARMINGTON, CT. SN 77-463,118. PUB. 4-7-2009, FILED 5-1-2008.

Youshook

THE MARK CONSISTS OF STANDARD CHARACTERS WITHOUT CLAIM TO ANY PARTICULAR FONT, STYLE, SIZE, OR COLOR.

THE WORDING "YOUSHOOK" HAS NO MEANING IN A FOREIGN LANGUAGE.

FOR ONLINE JOURNALS, NAMELY, BLOGS AND VIDEO JOURNALS FEATURING MUSIC AND ENTERTAINMENT (U.S. CLS. 100, 101 AND 107).

FIRST USE 4-10-2007; IN COMMERCE 4-10-2007.

**CLASS 41—(Continued).**

3,941,092. JERRY LANIER, LOS ANGELES, CA. SN 77-490,998. PUB. 12-23-2008, FILED 6-4-2008.



THE MARK CONSISTS OF THE LETTER "C" AND NUMBER "7" CONJOINED ON A CIRCULAR BACKGROUND.

FOR PRODUCTION AND DISTRIBUTION OF TELEVISION PROGRAMS OVER A PRIVATE TELEVISION NETWORK FEATURING MUSIC, LIFESTYLE CONTENT, AND ORIGINAL PROGRAMMING (U.S. CLS. 100, 101 AND 107).

FIRST USE 7-1-2010; IN COMMERCE 7-1-2010.

---

3,941,100. 4KIDS ENTERTAINMENT, INC., NEW YORK, NY. SN 77-510,192. PUB. 11-25-2008, FILED 6-27-2008.



THE MARK CONSISTS OF THE TERM "GOGORIKI" WITH THE SECOND "O" ENLARGED, THE TERM BEING FRAMED AND HAVING A SHADED BACKGROUND.

FOR ENTERTAINMENT SERVICES, NAMELY, PRODUCTION OF TELEVISION PROGRAMS (U.S. CLS. 100, 101 AND 107).

FIRST USE 8-15-2009; IN COMMERCE 8-15-2009.

**CLASS 41—(Continued).**

3,941,103. JIFFY LUBE INTERNATIONAL, INC, HOUSTON, TX. SN 77-512,622. PUB. 12-8-2009, FILED 7-1-2008.



OWNER OF U.S. REG. NOS. 1,384,672, 3,496,989, AND OTHERS.

NO CLAIM IS MADE TO THE EXCLUSIVE RIGHT TO USE "LUBE UNIVERSITY", APART FROM THE MARK AS SHOWN.

THE MARK CONSISTS OF THE LETTERING "JLU", THE WORDING "INTEGRITY EXCELLENCE INNOVATION", AND A DESIGN CONSISTING OF THREE STARS. ALL SUPERIMPOSED ON A SHIELD DESIGN, BENEATH WHICH IS THE WORDING "JIFFY LUBE UNIVERSITY".

FOR TRAINING FOR DISTRIBUTORS OF LUBRICATION SERVICES IN THE FIELD OF COMPUTER BASED LUBRICATION SERVICES, AND DISTRIBUTING COURSE MATERIALS IN CONNECTION THEREWITH (U.S. CLS. 100, 101 AND 107).

FIRST USE 7-1-2008; IN COMMERCE 7-1-2008.

3,941,106. RUSSELL, JEFFREY L., WARREN, MI. SN 77-518,995. PUB. 12-9-2008, FILED 7-10-2008.

par-tee miniature golf

THE MARK CONSISTS OF STANDARD CHARACTERS WITHOUT CLAIM TO ANY PARTICULAR FONT, STYLE, SIZE, OR COLOR.

NO CLAIM IS MADE TO THE EXCLUSIVE RIGHT TO USE "MINIATURE GOLF", APART FROM THE MARK AS SHOWN.

FOR ENTERTAINMENT SERVICES, NAMELY, PARTICIPATION IN MINIATURE GOLF GAMES (U.S. CLS. 100, 101 AND 107).

FIRST USE 5-12-2009; IN COMMERCE 6-2-2009.

**CLASS 41—(Continued).**

3,941,141. MOORE SR, JAMES C., OAKLAND, CA. SN 77-584,008. PUB. 7-6-2010, FILED 10-2-2008.

SUGAR PIE DE SANTO

THE MARK CONSISTS OF STANDARD CHARACTERS WITHOUT CLAIM TO ANY PARTICULAR FONT, STYLE, SIZE, OR COLOR.

THE NAME IN THE MARK IDENTIFIES A LIVING INDIVIDUAL WHOSE CONSENT IS OF RECORD.

FOR ENTERTAINMENT IN THE NATURE OF LIVE PERFORMANCES BY AN R AND B SINGER (U.S. CLS. 100, 101 AND 107).

FIRST USE 11-14-1959; IN COMMERCE 11-14-1959.

3,941,164. VALLEY CHRISTIAN SCHOOLS, INC., SAN JOSE, CA. SN 77-615,083. PUB. 10-20-2009, FILED 11-14-2008.

A<sup>3</sup>

THE MARK CONSISTS OF THE LETTER "A" AND THE EXPONENT "3".

FOR PRIVATE CHRISTIAN EDUCATIONAL SCHOOL SERVICES, NAMELY, PROVIDING EDUCATIONAL PROGRAMS AT THE K-12 LEVEL WHICH INCLUDES PROGRAMS IN THE ARTS AND ATHLETICS (U.S. CLS. 100, 101 AND 107).

FIRST USE 8-31-2009; IN COMMERCE 8-31-2009.

3,941,169. BLACK MOR, LLC, MERIDIAN, ID. SN 77-621,985. PUB. 11-17-2009, FILED 11-25-2008.

WAHOZ FAMILY FUN ZONE

THE MARK CONSISTS OF STANDARD CHARACTERS WITHOUT CLAIM TO ANY PARTICULAR FONT, STYLE, SIZE, OR COLOR.

**CLASS 41—(Continued).**

NO CLAIM IS MADE TO THE EXCLUSIVE RIGHT TO USE "FAMILY FUN ZONE", APART FROM THE MARK AS SHOWN.

FOR AMUSEMENT CENTERS AND ENTERTAINMENT SERVICES IN THE NATURE OF ARCADE GAMES, LASER TAG, GO-CART TRACKS, BUMPER BOATS, BATTING CAGES, AND MINIATURE GOLF COURSES (U.S. CLS. 100, 101 AND 107).

FIRST USE 1-1-2009; IN COMMERCE 1-1-2009.

---

3,941,195. EVERLY, LLC, BATTLE GROUND, WA. SN 77-648,353. PUB. 5-5-2009, FILED 1-13-2009.

EVERLY

THE MARK CONSISTS OF STANDARD CHARACTERS WITHOUT CLAIM TO ANY PARTICULAR FONT, STYLE, SIZE, OR COLOR.

FOR ENTERTAINMENT, NAMELY, LIVE PERFORMANCES BY A MUSICAL BAND (U.S. CLS. 100, 101 AND 107).

FIRST USE 11-1-2008; IN COMMERCE 11-1-2008.

---

3,941,209. MUDGE, ALFRED GEORGE, WASSAIC, NY. SN 77-661,443. PUB. 10-27-2009, FILED 2-2-2009.

USE THE VISUAL TO  
STIMULATE THE VERBAL

THE MARK CONSISTS OF STANDARD CHARACTERS WITHOUT CLAIM TO ANY PARTICULAR FONT, STYLE, SIZE, OR COLOR.

FOR EDUCATIONAL SERVICES, NAMELY, CONDUCTING CLASSES, SEMINARS AND WORKSHOPS FOR LANGUAGE AND VOCATIONAL TRAINING (U.S. CLS. 100, 101 AND 107).

FIRST USE 9-22-2009; IN COMMERCE 9-22-2009.

**CLASS 41—(Continued).**

3,941,210. MUDGE, ALFRED GEORGE, WASSAIC, NY. SN 77-661,460. PUB. 10-27-2009, FILED 2-2-2009.

UVSV

THE MARK CONSISTS OF STANDARD CHARACTERS WITHOUT CLAIM TO ANY PARTICULAR FONT, STYLE, SIZE, OR COLOR.

FOR EDUCATIONAL SERVICES, NAMELY, CONDUCTING CLASSES, SEMINARS AND WORKSHOPS FOR LANGUAGE AND VOCATIONAL TRAINING (U.S. CLS. 100, 101 AND 107).

FIRST USE 9-22-2009; IN COMMERCE 9-22-2009.

---

3,941,214. THINK GLOBAL SCHOOL, INC., SAN FRANCISCO, CA. SN 77-662,915. PUB. 5-12-2009, FILED 2-4-2009.

THINK  
GLOBAL  
SCHOOL



NO CLAIM IS MADE TO THE EXCLUSIVE RIGHT TO USE "GLOBAL SCHOOL", APART FROM THE MARK AS SHOWN.

THE MARK CONSISTS OF THE WORDS "THINK GLOBAL SCHOOL" STACKED ON TOP OF EACH OTHER WITH THE TERM "TGS" ON THE RIGHT SIDE OF THE STACKED WORDS.

FOR EDUCATIONAL SERVICES, NAMELY, BOARDING SCHOOL (U.S. CLS. 100, 101 AND 107).

FIRST USE 9-13-2010; IN COMMERCE 9-13-2010.

---

3,941,216. HOOD, YUSEF, DBA HOODFILMS, CHICAGO, IL. SN 77-666,077. PUB. 3-23-2010, FILED 2-9-2009.

HOODFILMS

THE MARK CONSISTS OF STANDARD CHARACTERS WITHOUT CLAIM TO ANY PARTICULAR FONT, STYLE, SIZE, OR COLOR.

FOR PRODUCTION AND DISTRIBUTION OF TELEVISION SHOWS AND MOVIES (U.S. CLS. 100, 101 AND 107).

FIRST USE 8-20-1999; IN COMMERCE 8-20-2000.

**CLASS 41—(Continued).**

3,941,231. ARTVIC, LLC, NEW YORK, NY. SN 77-680,181. PUB. 7-28-2009, FILED 2-27-2009.

**VICART ENTERTAINMENT**

THE MARK CONSISTS OF STANDARD CHARACTERS WITHOUT CLAIM TO ANY PARTICULAR FONT, STYLE, SIZE, OR COLOR.

NO CLAIM IS MADE TO THE EXCLUSIVE RIGHT TO USE "ENTERTAINMENT", APART FROM THE MARK AS SHOWN.

FOR ENTERTAINMENT, NAMELY, PRODUCTION OF MUSIC, MOTION PICTURE FILMS, VIDEO DISCS FOR OTHERS, VIDEO CASSETTES, SOUND AND MUSIC VIDEO RECORDINGS, VIDEO DISCS AND TAPES; MOTION PICTURE FILM PRODUCTION; MUSIC PRODUCTION SERVICES; MULTIMEDIA ENTERTAINMENT SERVICES IN THE NATURE OF RECORDING, PRODUCTION AND POST-PRODUCTION SERVICES IN THE FIELDS OF MUSIC, VIDEO AND FILMS; MUSIC PRODUCTION SERVICES; PRODUCTION AND DISTRIBUTION OF INDEPENDENT MOTION PICTURES; PRODUCTION AND DISTRIBUTION OF MOTION PICTURES; PRODUCTION OF SOUND AND MUSIC VIDEO RECORDINGS; AUDIO RECORDING AND PRODUCTION; POST-PRODUCTION EDITING SERVICES IN THE FIELD OF MUSIC, VIDEOS AND FILMS; PRODUCTION AND DISTRIBUTION OF TELEVISION SHOWS AND MOVIES; PRODUCTION OF DVDS, VIDEOTAPES AND TELEVISION PROGRAMS FEATURING MUSIC, MUSIC VIDEOS, FILMS, INDEPENDENT FILMS, AND COMMERCIALS (U.S. CLS. 100, 101 AND 107).

FIRST USE 4-30-2009; IN COMMERCE 4-30-2009.

3,941,233. MAMA PRODUCTIONS, INC., AGOURA HILLS, CA. SN 77-683,354. PUB. 10-6-2009, FILED 3-4-2009.

**I KNOW A WOMAN LIKE THAT**

THE MARK CONSISTS OF STANDARD CHARACTERS WITHOUT CLAIM TO ANY PARTICULAR FONT, STYLE, SIZE, OR COLOR.

FOR EDUCATIONAL AND ENTERTAINMENT SERVICES, NAMELY, FILM SCREENINGS, ORGANIZING AND LEADING DISCUSSIONS, SEMINARS, CONFERENCES AND WORKSHOPS AND PROVIDING MOTIVATIONAL AND EDUCATIONAL SPEAKERS ALL IN THE FIELDS OF EMPOWERMENT OF WOMEN, WOMEN'S ISSUES, WOMEN'S LEADERSHIP AND WOMEN'S PERSONAL AND PROFESSIONAL DEVELOPMENT (U.S. CLS. 100, 101 AND 107).

FIRST USE 10-31-2009; IN COMMERCE 10-31-2009.

**CLASS 41—(Continued).**

3,941,242. AOL INC., DULLES, VA. SN 77-694,941. PUB. 12-1-2009, FILED 3-19-2009.

**BV NEWSWIRE**

THE MARK CONSISTS OF STANDARD CHARACTERS WITHOUT CLAIM TO ANY PARTICULAR FONT, STYLE, SIZE, OR COLOR.

NO CLAIM IS MADE TO THE EXCLUSIVE RIGHT TO USE "NEWSWIRE", APART FROM THE MARK AS SHOWN.

FOR ONLINE JOURNALS, NAMELY, BLOGS IN THE FIELD OF ENTERTAINMENT (U.S. CLS. 100, 101 AND 107).

FIRST USE 2-1-2011; IN COMMERCE 2-1-2011.

3,941,246. MISSISSIPPI CHILDREN'S MUSEUM, JACKSON, MS. SN 77-700,263. PUB. 7-28-2009, FILED 3-26-2009.



NO CLAIM IS MADE TO THE EXCLUSIVE RIGHT TO USE "MISSISSIPPI CHILDREN'S MUSEUM", APART FROM THE MARK AS SHOWN.

THE MARK CONSISTS OF THE WORDS "MISSISSIPPI CHILDREN'S MUSEUM" UNDER A STYLIZED "M", WHICH IS FORMED BY A ROCKET, THE TRAIL OF A ROCKET, EIGHT SHADED TRIANGLES, AND AN OPEN BOOK.

FOR EDUCATIONAL AND ENTERTAINMENT SERVICES IN THE NATURE OF A CHILDREN'S MUSEUM (U.S. CLS. 100, 101 AND 107).

FIRST USE 12-2-2010; IN COMMERCE 12-2-2010.

**CLASS 41—(Continued).**

3,941,265. MCWILLIAMS, BRUCE, ADDISON, TX. SN 77-725,705. PUB. 9-8-2009, FILED 4-30-2009.

# LifeLines

THE MARK CONSISTS OF STANDARD CHARACTERS WITHOUT CLAIM TO ANY PARTICULAR FONT, STYLE, SIZE, OR COLOR.

FOR EDUCATION SERVICES, NAMELY, PROVIDING CLASSES, SEMINARS AND WORKSHOPS IN THE FIELD OF WRITING PERSONAL MEMOIRS (U.S. CLS. 100, 101 AND 107).

FIRST USE 6-6-2010; IN COMMERCE 6-6-2010.

---

3,941,322. TRUSTEES OF DARTMOUTH, HANOVER, NH. SN 77-765,848. PUB. 6-1-2010, FILED 6-23-2009.

WHERE KNOWLEDGE INFORMS  
CHANGE

THE MARK CONSISTS OF STANDARD CHARACTERS WITHOUT CLAIM TO ANY PARTICULAR FONT, STYLE, SIZE, OR COLOR.

FOR EDUCATIONAL SERVICES, NAMELY, CONDUCTING PROGRAMS, CLASSES, SEMINARS, WORKSHOPS, LABS AND RESEARCH TUTORIALS IN THE FIELD OF THE HEALTH CARE INDUSTRY AND HEALTH CARE SYSTEM REFORM (U.S. CLS. 100, 101 AND 107).

FIRST USE 8-1-2007; IN COMMERCE 10-10-2007.

---

3,941,371. MICHAEL DIMARTINO, SANTA CRUZ, CA. SN 77-784,753. PUB. 5-25-2010, FILED 7-20-2009.

RHYTHM THE EVOLUTIONARY  
MUSICAL

THE MARK CONSISTS OF STANDARD CHARACTERS WITHOUT CLAIM TO ANY PARTICULAR FONT, STYLE, SIZE, OR COLOR.

NO CLAIM IS MADE TO THE EXCLUSIVE RIGHT TO USE "MUSICAL", APART FROM THE MARK AS SHOWN.

FOR ENTERTAINMENT SERVICES, NAMELY, THE PRODUCTION OF CONTINUING MUSICAL AND DANCE PERFORMANCES; ENTERTAINMENT SERVICES IN THE NATURE OF LIVE MUSICAL AND DANCE PERFORMANCES (U.S. CLS. 100, 101 AND 107).

FIRST USE 8-23-2009; IN COMMERCE 8-23-2009.

**CLASS 41—(Continued).**

3,941,380. CNL INCOME MOUNTAIN HIGH TRS CORP., WILMINGTON, DE. SN 77-786,951. PUB. 6-29-2010, FILED 7-22-2009.



OWNER OF U.S. REG. NOS. 2,810,046 AND 2,827,213.  
THE MARK CONSISTS OF STYLIZED LETTERS "MH" WITH A STAR AND THE TERM "MOUNTAIN HIGH".  
FOR SKI RESORT SERVICES (U.S. CLS. 100, 101 AND 107).

FIRST USE 9-30-2002; IN COMMERCE 9-30-2002.

---

3,941,382. SPOT411 TECHNOLOGIES, INC., ORANGE, CA. SN 77-788,603. PUB. 6-8-2010, FILED 7-23-2009.

# SPOT411

THE MARK CONSISTS OF STANDARD CHARACTERS WITHOUT CLAIM TO ANY PARTICULAR FONT, STYLE, SIZE, OR COLOR.

FOR ENTERTAINMENT SERVICES, NAMELY, PROVIDING INFORMATION IN THE NATURE OF TEXT, AUDIO, GRAPHICS, STILL IMAGES AND MOVING PICTURES IN RESPONSE TO RECOGNIZED AUDIO TRANSMISSIONS FEATURING ACTION, ADVENTURE, COMEDY, CRIME, DOCUMENTARY, DRAMATIC, FANTASY, HISTORICAL, HORROR, MUSICAL, ROMANCE, SCIENCE FICTION, SPORT, THRILLER, WAR, AND WESTERN SUBJECT MATTER (U.S. CLS. 100, 101 AND 107).

FIRST USE 4-20-2010; IN COMMERCE 4-20-2010.



**CLASS 41—(Continued).**

3,941,460. REDEEMER CITYNET, NEW YORK, NY. SN 77-826,910. PUB. 6-22-2010, FILED 9-15-2009.

**LOVE YOUR CITY TO LIFE**

THE MARK CONSISTS OF STANDARD CHARACTERS WITHOUT CLAIM TO ANY PARTICULAR FONT, STYLE, SIZE, OR COLOR.

FOR AUDIO RECORDING AND PRODUCTION; DEVELOPMENT AND DISSEMINATION OF EDUCATIONAL MATERIALS OF OTHERS IN THE FIELD OF CHURCH PLANTING, URBAN RENEWAL AND RELIGIOUS INSTRUCTION; PROVIDING ONLINE PUBLICATIONS IN THE NATURE OF E-BOOKS, BLOGS, MANUALS, ARTICLES, AND PAPERS, ALL IN THE FIELD OF CHURCH PLANTING, URBAN RENEWAL AND RELIGIOUS INSTRUCTION; EDUCATIONAL SERVICES, NAMELY, DEVELOPING, ARRANGING, AND CONDUCTING EDUCATIONAL CONFERENCES, SEMINARS, WORKSHOPS AND PROGRAMS AND PROVIDING COURSES OF INSTRUCTION IN THE FIELD OF CHURCH PLANTING, URBAN RENEWAL AND RELIGIOUS INSTRUCTION, AND DISTRIBUTION OF COURSE MATERIAL IN CONNECTION THEREWITH; PROVIDING PODCASTS IN THE FIELD OF CHURCH PLANTING, URBAN RENEWAL AND RELIGIOUS INSTRUCTION; FILM AND VIDEO PRODUCTION; PROVIDING A WEBSITE THAT FEATURES INFORMAL INSTRUCTION ON CHURCH PLANTING, URBAN RENEWAL AND RELIGIOUS INSTRUCTION (U.S. CLS. 100, 101 AND 107).

FIRST USE 1-31-2010; IN COMMERCE 1-31-2010.

3,941,485. HARVEY EARL JACOBS, MIDLOTHIAN, VA. SN 77-840,062. PUB. 6-1-2010, FILED 10-2-2009.

**Don't "Don't!"**

THE MARK CONSISTS OF STANDARD CHARACTERS WITHOUT CLAIM TO ANY PARTICULAR FONT, STYLE, SIZE, OR COLOR.

FOR TRAINING SERVICES IN THE FIELD OF PSYCHOLOGY AND EDUCATION (U.S. CLS. 100, 101 AND 107).

FIRST USE 3-26-2010; IN COMMERCE 3-26-2010.

**CLASS 41—(Continued).**

3,941,556. DISH NETWORK, L.L.C., ENGLEWOOD, CO. SN 77-872,007. PUB. 4-20-2010, FILED 11-13-2009.

**MIDNIGHT LOUNGE**

THE MARK CONSISTS OF STANDARD CHARACTERS WITHOUT CLAIM TO ANY PARTICULAR FONT, STYLE, SIZE, OR COLOR.

FOR DISTRIBUTION OF TELEVISION PROGRAMS FOR OTHERS; PROVIDING ADULT ORIENTED ENTERTAINMENT INFORMATION; PROVIDING ENTERTAINMENT IN THE NATURE OF ON-GOING TELEVISION PROGRAMS IN THE FIELDS OF ADULT ENTERTAINMENT AND ADULT ORIENTED MOVIES (U.S. CLS. 100, 101 AND 107).

FIRST USE 12-31-2009; IN COMMERCE 12-31-2009.

3,941,567. PERPETUAL MOTION FITNESS CORPORATION, CHICAGO, IL. SN 77-874,724. PUB. 4-20-2010, FILED 11-17-2009.

**inerTRAIN**

THE MARK CONSISTS OF STANDARD CHARACTERS WITHOUT CLAIM TO ANY PARTICULAR FONT, STYLE, SIZE, OR COLOR.

FOR PROVIDING A WEB SITE FEATURING INFORMATION ON EXERCISE AND FITNESS; PROVIDING ASSISTANCE, PERSONAL TRAINING AND PHYSICAL FITNESS CONSULTATION TO INDIVIDUALS TO HELP THEM MAKE PHYSICAL FITNESS, STRENGTH, CONDITIONING, AND EXERCISE IMPROVEMENT IN THEIR DAILY LIVING (U.S. CLS. 100, 101 AND 107).

FIRST USE 1-1-2010; IN COMMERCE 6-1-2010.

3,941,581. CHURCHILL DOWNS INCORPORATED, LOUISVILLE, KY. SN 77-878,560. PUB. 4-27-2010, FILED 11-23-2009.



churchill downs entertainment

OWNER OF U.S. REG. NO. 3,158,512.

NO CLAIM IS MADE TO THE EXCLUSIVE RIGHT TO USE "ENTERTAINMENT", APART FROM THE MARK AS SHOWN.

THE COLOR(S) BLUE, ORANGE, PINK, WHITE, AND GRAY IS/ARE CLAIMED AS A FEATURE OF THE MARK.

**CLASS 41—(Continued).**

THE MARK CONSISTS OF THREE OVERLAPPING CIRCLES, EACH HAVING A WHITE UPPER-CASE LETTER IN ITS MIDDLE, ARRANGED FROM LEFT TO RIGHT, A BLUE CIRCLE WITH THE LETTER "C", AN ORANGE CIRCLE WITH THE LETTER "D", AND A PINK CIRCLE WITH THE LETTER "E", ALL ABOVE THE WORDS "CHURCHILL DOWNS ENTERTAINMENT" IN LOWER CASE GRAY LETTERS.

FOR ARRANGING AND CONDUCTING OF CONCERTS; ARRANGING AND CONDUCTING SPECIAL EVENTS, SPECIAL EVENT PLANNING; PROVIDING AN INTERNET WEBSITE PORTAL FEATURING LINKS TO MUSICAL ARTIST WEBSITES AND MUSIC PERFORMANCE TICKET INFORMATION; ARRANGING FOR TICKET RESERVATIONS FOR SHOWS AND OTHER ENTERTAINMENT EVENTS; PROVIDING INFORMATION IN THE FIELD OF SPECIAL EVENTS AND EVENT TICKET INFORMATION (U.S. CLS. 100, 101 AND 107).

FIRST USE 11-1-2009; IN COMMERCE 11-1-2009.

---

3,941,676. KIDDIE CRUSOE, LLC, FOREST HILL, MD. SN 77-898,257. PUB. 5-25-2010, FILED 12-21-2009.

**KIDDIE CRUSOE**

THE MARK CONSISTS OF STANDARD CHARACTERS WITHOUT CLAIM TO ANY PARTICULAR FONT, STYLE, SIZE, OR COLOR.

NO CLAIM IS MADE TO THE EXCLUSIVE RIGHT TO USE "KIDDIE", APART FROM THE MARK AS SHOWN.

FOR PROVIDING CHILDREN'S PARTY CENTERS FOR THE PURPOSE OF ENTERTAINING CHILDREN AND CELEBRATING BIRTHDAYS; PROVIDING RECREATIONAL AREAS IN THE NATURE OF CHILDREN'S PLAY AREAS (U.S. CLS. 100, 101 AND 107).

FIRST USE 8-27-2010; IN COMMERCE 9-5-2010.

---

3,941,695. MCKENNA, SIOBHAN, SAN DIEGO, CA. SN 77-900,488. PUB. 5-18-2010, FILED 12-23-2009.

**ARCHITECT YOUR BEST LIFE**

THE MARK CONSISTS OF STANDARD CHARACTERS WITHOUT CLAIM TO ANY PARTICULAR FONT, STYLE, SIZE, OR COLOR.

FOR EDUCATIONAL AND ENTERTAINMENT SERVICES, NAMELY, PROVIDING MOTIVATIONAL SPEAKING SERVICES IN THE FIELD OF LIFE SUCCESS; LIFE COACHING SERVICES IN THE FIELD OF LIFE SUCCESS (U.S. CLS. 100, 101 AND 107).

FIRST USE 8-1-2008; IN COMMERCE 8-1-2008.

**CLASS 41—(Continued).**

3,941,696. PEDERSEN, KAARE, EFFINGHAM, IL. SN 77-900,634. PUB. 5-18-2010, FILED 12-23-2009.



THE MARK CONSISTS OF THE STYLIZED TEXT "DOLLARISM".

FOR TRAINING COURSES IN STRATEGIC PLANNING RELATING TO ADVERTISING, PROMOTION, MARKETING AND BUSINESS (U.S. CLS. 100, 101 AND 107).

FIRST USE 3-20-2010; IN COMMERCE 3-20-2010.

---

3,941,715. HURST, ROBIN W. RICHMOND, VA. SN 77-904,026. PUB. 5-18-2010, FILED 1-3-2010.

**ALL IN Retreats**

THE MARK CONSISTS OF STANDARD CHARACTERS WITHOUT CLAIM TO ANY PARTICULAR FONT, STYLE, SIZE, OR COLOR.

NO CLAIM IS MADE TO THE EXCLUSIVE RIGHT TO USE "RETREATS", APART FROM THE MARK AS SHOWN.

FOR EDUCATIONAL SERVICES, NAMELY, DEVELOPING AND CONDUCTING WORKOUTS, WORKSHOPS, PRESENTATIONS, RETREATS, AND PERSONAL TRAINING IN RIGHT-BRAIN FITNESS (U.S. CLS. 100, 101 AND 107).

FIRST USE 2-1-2010; IN COMMERCE 9-21-2010.

---

3,941,719. PHN, LLC, DANVILLE, CA. SN 77-904,473. PUB. 6-1-2010, FILED 1-4-2010.

**VANGUARD KRAV MAGA**

THE MARK CONSISTS OF STANDARD CHARACTERS WITHOUT CLAIM TO ANY PARTICULAR FONT, STYLE, SIZE, OR COLOR.

NO CLAIM IS MADE TO THE EXCLUSIVE RIGHT TO USE "KRAV MAGA", APART FROM THE MARK AS SHOWN.

**CLASS 41—(Continued).**

THE ENGLISH TRANSLATION OF "KRAV MAGA" IN THE MARK IS "CONTACT COMBAT".

FOR EXERCISE PROGRAM INCORPORATING DRILLS AND EXERCISES BASED ON FIGHTING AND SELF-DEFENSE SKILLS; EDUCATIONAL SERVICES, NAMELY, CONDUCTING CERTIFICATION CLASSES AND PROVIDING LESSON PLANS FOR INSTRUCTOR TRAINING IN EXERCISE PROGRAM INCORPORATING DRILLS AND EXERCISES BASED ON FIGHTING AND SELF-DEFENSE SKILLS (U.S. CLS. 100, 101 AND 107).

FIRST USE 1-18-2010; IN COMMERCE 1-8-2011.

3,941,756. GIRLFRIEND U, LLC, SCOTTSDALE, AZ. SN 77-911,964. PUB. 6-1-2010, FILED 1-14-2010.

**GIRLFRIEND U**

THE MARK CONSISTS OF STANDARD CHARACTERS WITHOUT CLAIM TO ANY PARTICULAR FONT, STYLE, SIZE, OR COLOR.

FOR EDUCATIONAL SERVICES, NAMELY, CONDUCTING CLASSES, SEMINARS, CONFERENCES AND WORKSHOPS IN THE FIELD OF SELF- AND PERSONAL IMPROVEMENT AND DISTRIBUTION OF PRINTED MATERIALS IN CONNECTION THEREWITH IN HARD COPY OR ELECTRONIC FORMAT ON THE SAME TOPICS; EDUCATIONAL SERVICES, NAMELY, PROVIDING ON-LINE CLASSES, SEMINARS AND WORKSHOPS IN THE FIELD OF SELF- AND PERSONAL IMPROVEMENT; EDUCATIONAL SERVICES, NAMELY, PROVIDING MOTIVATIONAL AND EDUCATIONAL SPEAKERS IN THE FIELDS OF SELF- AND PERSONAL IMPROVEMENT (U.S. CLS. 100, 101 AND 107).

FIRST USE 1-31-2010; IN COMMERCE 1-31-2010.

3,941,757. GIRLFRIEND U, LLC, SCOTTSDALE, AZ. SN 77-911,968. PUB. 6-1-2010, FILED 1-14-2010.

**GIRLFRIEND UNIVERSITY**

THE MARK CONSISTS OF STANDARD CHARACTERS WITHOUT CLAIM TO ANY PARTICULAR FONT, STYLE, SIZE, OR COLOR.

FOR EDUCATIONAL SERVICES, NAMELY, CONDUCTING CLASSES, SEMINARS, CONFERENCES AND WORKSHOPS IN THE FIELD OF SELF- AND PERSONAL IMPROVEMENT AND DISTRIBUTION OF PRINTED MATERIALS IN CONNECTION THEREWITH IN HARD COPY OR ELECTRONIC FORMAT ON THE SAME TOPICS; EDUCATIONAL SERVICES, NAMELY, PROVIDING ON-LINE CLASSES, SEMINARS AND WORKSHOPS IN THE FIELD OF SELF- AND PERSONAL IMPROVEMENT; EDUCATIONAL SERVICES, NAMELY, PROVIDING MOTIVATIONAL AND EDUCATIONAL SPEAKERS IN THE FIELDS OF SELF- AND PERSONAL IMPROVEMENT (U.S. CLS. 100, 101 AND 107).

FIRST USE 1-31-2010; IN COMMERCE 1-31-2010.

**CLASS 41—(Continued).**

3,941,759. TAMARA SCHILLING, GLENDALE, AZ. SN 77-912,777. PUB. 6-1-2010, FILED 1-15-2010.

**RELATIONSHIPT**

THE MARK CONSISTS OF STANDARD CHARACTERS WITHOUT CLAIM TO ANY PARTICULAR FONT, STYLE, SIZE, OR COLOR.

FOR EDUCATIONAL AND ENTERTAINMENT SERVICES, NAMELY, A CONTINUING PROGRAM ABOUT PERSONAL IMPROVEMENT, BUSINESS RELATIONSHIPS, PERSONAL RELATIONSHIPS AND PROFESSIONAL RELATIONSHIPS ACCESSIBLE BY RADIO, TELEVISION, SATELLITE, AUDIO, VIDEO AND COMPUTER NETWORKS; EDUCATIONAL SERVICES, NAMELY, CONDUCTING SEMINARS AND WORKSHOPS IN THE FIELD OF PERSONAL IMPROVEMENT, BUSINESS RELATIONSHIPS, PERSONAL RELATIONSHIPS AND PROFESSIONAL RELATIONSHIPS AND DISTRIBUTION OF PRINTED MATERIALS IN CONNECTION THEREWITH IN HARD COPY OR ELECTRONIC FORMAT ON THE SAME TOPICS (U.S. CLS. 100, 101 AND 107).

FIRST USE 2-14-2009; IN COMMERCE 2-14-2009.

3,941,774. FLORIDA PANTHERS HOCKEY CLUB, LTD., SUNRISE, FL. SN 77-914,454. PUB. 6-1-2010, FILED 1-19-2010.



OWNER OF U.S. REG. NOS. 1,876,001, 2,114,376, AND OTHERS.

NO CLAIM IS MADE TO THE EXCLUSIVE RIGHT TO USE "FLORIDA", APART FROM THE MARK AS SHOWN.

THE MARK CONSISTS OF THE WORDS "FLORIDA PANTHERS" APPEARING WITHIN THE BORDER OF A CIRCLE WITH THE TERM "FLORIDA" ALONG THE TOP ARC, THE TERM "PANTHERS" ALONG THE BOTTOM ARC AND TWO SMALL DOTS SEPARATING THE TERMS. THE DESIGN OF A PANTHER HEAD APPEARS ON THE INTERIOR OF THE CIRCLE.

FOR ENTERTAINMENT SERVICES, NAMELY, ICE HOCKEY EXHIBITIONS (U.S. CLS. 100, 101 AND 107).

FIRST USE 11-23-2009; IN COMMERCE 11-23-2009.

**CLASS 41—(Continued).**

3,941,827. GARY SHURLEY, SACRAMENTO, CA. SN 77-921,291. PUB. 6-15-2010, FILED 1-27-2010.

**BADGE VS BADGE**

THE MARK CONSISTS OF STANDARD CHARACTERS WITHOUT CLAIM TO ANY PARTICULAR FONT, STYLE, SIZE, OR COLOR.

FOR ORGANIZING SPORTING EVENTS, NAMELY, BOXING MATCHES (U.S. CLS. 100, 101 AND 107).  
FIRST USE 5-1-2010; IN COMMERCE 5-21-2010.

3,941,859. DUPITON, DARNLEY, RICHMOND HILL, NY. SN 77-927,558. PUB. 10-26-2010, FILED 2-3-2010.

**SoulClef**

THE MARK CONSISTS OF STANDARD CHARACTERS WITHOUT CLAIM TO ANY PARTICULAR FONT, STYLE, SIZE, OR COLOR.

FOR PROVIDING ON-LINE INFORMATION IN THE FIELD OF CURRENT EVENTS AND ENTERTAINMENT VIA THE INTERNET; PROVIDING AN ON-LINE COMPUTER DATABASE FEATURING INFORMATION IN THE FIELD OF CURRENT EVENTS AND ENTERTAINMENT-RELATED TOPICS; ENTERTAINMENT SERVICES, NAMELY, PROVIDING ONLINE NON-DOWNLOADABLE PRE-RECORDED MUSIC AND THEATER PERFORMANCES, ONGOING MOVIES, TELEVISION, AND RADIO SHOWS FEATURING NEWS, COMMENTARY, COMEDY, MUSIC AND SPORTS PERFORMANCES PRESENTED TO MOBILE COMMUNICATION DEVICES VIA WIRELESS NETWORKS; ENTERTAINMENT SERVICES, NAMELY, PRODUCTION OF MUSIC AND THEATER PERFORMANCES, FILMS, TELEVISION AND RADIO PROGRAMS AND PROVIDING ONLINE NON-DOWNLOADABLE PRE-RECORDED MUSIC AND THEATER PERFORMANCES, ONGOING MOVIES, TELEVISION, AND RADIO SHOWS FEATURING NEWS, COMMENTARY, COMEDY, MUSIC AND SPORTS PERFORMANCES PRESENTED TO MOBILE COMMUNICATION DEVICES VIA WIRELESS NETWORKS; ON-LINE PUBLISHING OF ELECTRONIC PUBLICATIONS; ENTERTAINMENT SERVICES,

**CLASS 41—(Continued).**

NAMELY, PROVIDING ON-LINE COMPUTER GAMES; ON-LINE JOURNALS, NAMELY, BLOGS FEATURING INFORMATION AND OPINIONS IN FIELD OF MUSIC, FILMS, SPORTS, ARTS ENTERTAINMENT; ENTERTAINMENT INFORMATION IN THE NATURE OF MOVIE SCHEDULES AND MOVIE LOCATIONS; ENTERTAINMENT SERVICES IN THE NATURE OF ORGANIZING, ARRANGING AND CONDUCTING COMMUNITY ENTERTAINMENT CULTURAL EVENTS, NAMELY, MUSICAL PERFORMANCES, FILM FESTIVALS, THEATRICAL PRODUCTIONS, TALENT CONTESTS, AND ART SHOWS; ENTERTAINMENT IN THE NATURE OF ORGANIZING LIVE MUSICAL PERFORMANCES FOR TELEVISION AND RADIO SHOWS; ORGANIZING CULTURAL AND COMMUNITY SPORTING EVENTS; ENTERTAINMENT IN THE NATURE OF CONDUCTING CONTESTS AND COMPETITIONS AND ORGANIZING GAMES, ALL OF THE FOREGOING IN THE FIELDS OF COMMUNITY SPORTS, MUSIC, LITERATURE, FILM AND ART (U.S. CLS. 100, 101 AND 107).

FIRST USE 11-1-2009; IN COMMERCE 6-1-2010.

3,941,867. SHOWTIME NETWORKS INC., NEW YORK, NY. SN 77-929,115. PUB. 6-22-2010, FILED 2-5-2010.

**THE REAL L WORD**

THE MARK CONSISTS OF STANDARD CHARACTERS WITHOUT CLAIM TO ANY PARTICULAR FONT, STYLE, SIZE, OR COLOR.

OWNER OF U.S. REG. NOS. 2,883,277 AND 3,276,350.

FOR ENTERTAINMENT SERVICES, NAMELY, AN ONGOING REALITY BASED TELEVISION SERIES RENDERED THROUGH THE MEDIA OF TELEVISION, CABLE, SATELLITE, TELEPHONE AND BROADBAND SYSTEMS, AND VIA THE INTERNET, PORTABLE AND WIRELESS COMMUNICATION DEVICES; AND PROVIDING INFORMATION IN THE FIELD OF ENTERTAINMENT FEATURING INFORMATION ON REALITY BASED TELEVISION RENDERED VIA THE INTERNET, PORTABLE AND WIRELESS COMMUNICATION DEVICES (U.S. CLS. 100, 101 AND 107).  
FIRST USE 6-20-2010; IN COMMERCE 6-20-2010.

3,941,881. GAMEZEBO, INC., SAN FRANCISCO, CA. SN 77-931,008. PUB. 6-29-2010, FILED 2-8-2010.

**We Love Casual Games**

THE MARK CONSISTS OF STANDARD CHARACTERS WITHOUT CLAIM TO ANY PARTICULAR FONT, STYLE, SIZE, OR COLOR.

**CLASS 41—(Continued).**

NO CLAIM IS MADE TO THE EXCLUSIVE RIGHT TO USE "CASUAL GAMES", APART FROM THE MARK AS SHOWN.

FOR ENTERTAINMENT SERVICES, NAMELY, PROVIDING ON-LINE COMPUTER GAMES; PROVIDING INFORMATION IN THE FIELD OF CASUAL ELECTRONIC GAMES; PROVIDING A WEBSITE FEATURING CASUAL ELECTRONIC GAMES AND INFORMATION ABOUT THEM (U.S. CLS. 100, 101 AND 107).

FIRST USE 2-0-2010; IN COMMERCE 2-0-2010.

3,941,882. THE REAL ESTATE LEARNING GROUP, LLC, PORTLAND, ME. SN 77-931,028. PUB. 6-22-2010, FILED 2-8-2010.



NO CLAIM IS MADE TO THE EXCLUSIVE RIGHT TO USE "REAL ESTATE", APART FROM THE MARK AS SHOWN.

THE MARK CONSISTS OF THE WORDING "REAL ESTATE SALES ADVANTAGE" IN A STYLIZED FONT AND A DESIGN THAT CONSISTS OF A SILHOUETTE OF A HOUSE, A RECTANGLE AND AN OVAL-SHAPED SHADOW. "REAL ESTATE" APPEARS IN THE HOUSE, "SALES" APPEARS IN THE SHADOW AND "ADVANTAGE" APPEARS IN THE RECTANGLE.

FOR EDUCATIONAL SERVICES, NAMELY, CONDUCTING WORKSHOPS AND PROGRAMS IN THE FIELD OF REAL ESTATE (U.S. CLS. 100, 101 AND 107).

FIRST USE 5-31-2010; IN COMMERCE 5-31-2010.

3,941,895. PEPPER JAY PRODUCTIONS, LLC., LOS ANGELES, CA. SN 77-934,045. PUB. 8-3-2010, FILED 2-11-2010.

**Tinsel on the Town**

THE MARK CONSISTS OF STANDARD CHARACTERS WITHOUT CLAIM TO ANY PARTICULAR FONT, STYLE, SIZE, OR COLOR.

FOR ENTERTAINMENT SERVICES, NAMELY, PROVIDING A WEBSITE AND WEBCASTS ALL IN THE FIELD OF ONGOING REALITY SHOWS ABOUT INSIDER HOLLYWOOD PARTIES AND EVENTS (U.S. CLS. 100, 101 AND 107).

FIRST USE 11-21-2009; IN COMMERCE 11-21-2009.

**CLASS 41—(Continued).**

3,941,940. FANTASY SPORTS NOW, INC., BOERNE, TX. SN 77-946,844. PUB. 7-27-2010, FILED 2-28-2010.

**FANTASY SPORTS NOW**

THE MARK CONSISTS OF STANDARD CHARACTERS WITHOUT CLAIM TO ANY PARTICULAR FONT, STYLE, SIZE, OR COLOR.

NO CLAIM IS MADE TO THE EXCLUSIVE RIGHT TO USE "FANTASY SPORTS", APART FROM THE MARK AS SHOWN.

FOR ENTERTAINMENT SERVICES IN THE NATURE OF FANTASY SPORTS LEAGUES (U.S. CLS. 100, 101 AND 107).

FIRST USE 11-1-2010; IN COMMERCE 11-1-2010.

3,941,941. FANTASY SPORTS NOW, INC., BOERNE, TX. SN 77-946,847. PUB. 7-27-2010, FILED 2-28-2010.

**FANTASY FOOTBALL NOW**

THE MARK CONSISTS OF STANDARD CHARACTERS WITHOUT CLAIM TO ANY PARTICULAR FONT, STYLE, SIZE, OR COLOR.

NO CLAIM IS MADE TO THE EXCLUSIVE RIGHT TO USE "FANTASY FOOTBALL", APART FROM THE MARK AS SHOWN.

FOR ENTERTAINMENT SERVICES IN THE NATURE OF FANTASY FOOTBALL LEAGUES (U.S. CLS. 100, 101 AND 107).

FIRST USE 9-9-2010; IN COMMERCE 9-9-2010.

3,941,952. QUALCOMM INCORPORATED, SAN DIEGO, CA. SN 77-951,720. PUB. 6-15-2010, FILED 3-5-2010.

**WWA**

THE MARK CONSISTS OF STANDARD CHARACTERS WITHOUT CLAIM TO ANY PARTICULAR FONT, STYLE, SIZE, OR COLOR.

FOR EDUCATIONAL SERVICES, NAMELY, TRAINING AND INSTRUCTIONAL SEMINARS IN THE FIELD OF WIRELESS COMMUNICATIONS (U.S. CLS. 100, 101 AND 107).

FIRST USE 3-22-2010; IN COMMERCE 3-22-2010.

**CLASS 41—(Continued).**

3,941,970. MARRIOTT INTERNATIONAL, INC., BETHESDA, MD. SN 77-958,781. PUB. 7-20-2010, FILED 3-15-2010.

**CRAZYBOX**

THE MARK CONSISTS OF STANDARD CHARACTERS WITHOUT CLAIM TO ANY PARTICULAR FONT, STYLE, SIZE, OR COLOR.

FOR NIGHT CLUBS (U.S. CLS. 100, 101 AND 107).  
FIRST USE 9-28-2010; IN COMMERCE 9-28-2010.

---

3,941,973. REDENBACHER, GARY FISH, SCOTTS VALLEY, CA. SN 77-958,832. PUB. 8-3-2010, FILED 3-15-2010.

**Diggerz**

THE MARK CONSISTS OF STANDARD CHARACTERS WITHOUT CLAIM TO ANY PARTICULAR FONT, STYLE, SIZE, OR COLOR.

FOR AMATEUR YOUTH SPORTS SERVICES, NAMELY, ORGANIZING AND PROVIDING YOUTH SPORTS ACTIVITIES (U.S. CLS. 100, 101 AND 107).  
FIRST USE 4-30-2010; IN COMMERCE 4-30-2010.

---

3,941,980. DISNEY ENTERPRISES, INC., BURBANK, CA. SN 77-961,136. PUB. 8-3-2010, FILED 3-17-2010.

**IMAGINE YOUR PLANET**

THE MARK CONSISTS OF STANDARD CHARACTERS WITHOUT CLAIM TO ANY PARTICULAR FONT, STYLE, SIZE, OR COLOR.

FOR EDUCATION SERVICES, NAMELY, CONDUCTING PROGRAMS FOR CHILDREN IN THE FIELD OF THE ENVIRONMENT AND CONSERVATION; ENTERTAINMENT SERVICES, NAMELY, CONDUCTING CONTESTS FOR CHILDREN TO PROMOTE AWARENESS OF ENVIRONMENTAL AND CONSERVATION ISSUES (U.S. CLS. 100, 101 AND 107).  
FIRST USE 2-28-2010; IN COMMERCE 2-28-2010.

**CLASS 41—(Continued).**

3,941,986. ARLENE TAVEROFF, DBA WISDOM A LA CARTE, DOLLARD DES ORMEAUX, CANADA. SN 77-963,846. PUB. 8-17-2010, FILED 3-19-2010.

**Wisdom a la Carte**

THE MARK CONSISTS OF STANDARD CHARACTERS WITHOUT CLAIM TO ANY PARTICULAR FONT, STYLE, SIZE, OR COLOR.

FOR ONLINE AND LIVE EDUCATIONAL SERVICES, NAMELY, CONDUCTING CLASSES, SEMINARS, CONFERENCES, AND WORKSHOPS IN THE FIELD OF SPIRITUALITY, WELL-BEING, RELIGION, PERSONAL GROWTH, COMMUNICATION SKILLS, SOCIAL MEDIA, AND SELF-IMPROVEMENT. PUBLICATIONS, NAMELY, NON-DOWNLOADABLE ELECTRONIC PUBLICATIONS IN THE NATURE OF NEWSLETTERS IN THE FIELD OF SPIRITUALITY, WELL-BEING, RELIGION, PERSONAL GROWTH, COMMUNICATION SKILLS, SOCIAL MEDIA, AND SELF-IMPROVEMENT (U.S. CLS. 100, 101 AND 107).

FIRST USE 1-1-2009; IN COMMERCE 3-20-2010.

---

3,942,033. DISNEY ENTERPRISES, INC., BURBANK, CA. SN 77-981,296. PUB. 4-28-2009, FILED 10-12-2007.

**CAMP ROCK**

THE MARK CONSISTS OF STANDARD CHARACTERS WITHOUT CLAIM TO ANY PARTICULAR FONT, STYLE, SIZE, OR COLOR.

OWNER OF U.S. REG. NO. 3,577,426.  
SEC. 2(F).  
FOR PRODUCTION OF LIVE STAGE SHOWS; PRESENTATION OF LIVE SHOW PERFORMANCES; THEATER PRODUCTIONS (U.S. CLS. 100, 101 AND 107).  
FIRST USE 10-31-2010; IN COMMERCE 10-31-2010.

**CLASS 41—(Continued).**

3,942,039. HIERARCHY, LLC, DBA HIERARCHY, LLC, WAYNE, MI. SN 77-981,399. PUB. 5-25-2010, FILED 11-30-2009.



THE MARK CONSISTS OF "HIERARCHY" WRITTEN IN JAGGED, SERRATED, AND TOOTHED LETTERING. FOR CONDUCTING ENTERTAINMENT EXHIBITIONS IN THE NATURE OF LIVE CHARACTER PERFORMANCE ART RELATING TO MIXED MARTIAL ARTS; ENTERTAINMENT IN THE NATURE OF LIVE PERFORMANCES BY MIXED MARTIAL ARTS CHARACTERS AND PERSONALITIES; PRESENTATION OF LIVE SHOW PERFORMANCES (U.S. CLS. 100, 101 AND 107).  
FIRST USE 7-24-2010; IN COMMERCE 7-24-2010.

3,942,041. HEROTAINMENT, LLC, SADDLE RIVER, NJ. SN 77-981,405. PUB. 6-15-2010, FILED 12-15-2008.



THE MARK CONSISTS OF THE WORD "HEROTOPIA" OVER A SHIELD DESIGN HAVING THE IMAGE OF A YOUNG HUMAN BEING. FOR ENTERTAINMENT SERVICES IN THE NATURE OF AN ON-LINE INTERACTIVE GAME PROVIDED BY MEANS OF A GLOBAL COMPUTER NETWORK; ENTERTAINMENT SERVICES IN THE NATURE OF AN ON-LINE INTERACTIVE GAME FEATURING A VIRTUAL WORLD WHERE USERS DESIGN THEIR OWN SUPERHERO AVATAR, PLAY GAMES TO EARN POINTS AND INTERACT WITH OTHERS, OFFERING BOTH FREE AND SUBSCRIPTION-BASED PLAY PROVIDED BY MEANS OF A GLOBAL COMPUTER NETWORK (U.S. CLS. 100, 101 AND 107).  
FIRST USE 7-1-2010; IN COMMERCE 7-1-2010.

**CLASS 41—(Continued).**

3,942,053. BIERMANN PRODUCTIONS LLC, WICHITA, KS. SN 78-639,660. PUB. 10-3-2006, FILED 5-30-2005.

Live Entertainment Choice

THE MARK CONSISTS OF STANDARD CHARACTERS WITHOUT CLAIM TO ANY PARTICULAR FONT, STYLE, SIZE, OR COLOR.  
NO CLAIM IS MADE TO THE EXCLUSIVE RIGHT TO USE "LIVE ENTERTAINMENT", APART FROM THE MARK AS SHOWN.  
FOR TELEVISION PRODUCTION SERVICES (U.S. CLS. 100, 101 AND 107).  
FIRST USE 11-20-2008; IN COMMERCE 11-20-2008.

3,942,060. HOMIESHOP PROPERTIES, L.L.C., HERCULES, CA. SN 78-812,670. PUB. 10-9-2007, FILED 2-10-2006.



THE MARK CONSISTS OF STANDARD CHARACTERS WITHOUT CLAIM TO ANY PARTICULAR FONT, STYLE, SIZE, OR COLOR.  
OWNER OF U.S. REG. NOS. 2,759,183 AND 2,798,134.  
THE FOREIGN WORDING IN THE MARK TRANSLATES INTO ENGLISH AS MY CHILDREN.  
FOR ENTERTAINMENT IN THE NATURE OF ONGOING TELEVISION PROGRAMS IN THE FIELD OF ANIMATION; THEATRE PRODUCTIONS; PRODUCTION AND DISTRIBUTION OF MOTION PICTURE FILMS (U.S. CLS. 100, 101 AND 107).  
FIRST USE 8-1-2010; IN COMMERCE 8-1-2010.

3,942,064. FIRST PRINCIPLES, INC., ALBANY, NY. SN 78-869,770. PUB. 2-10-2009, FILED 4-26-2006.



THE MARK CONSISTS OF STANDARD CHARACTERS WITHOUT CLAIM TO ANY PARTICULAR FONT, STYLE, SIZE, OR COLOR.  
FOR PROFESSIONAL COACHING SERVICES IN THE FIELD OF BUSINESS ORGANIZATION (U.S. CLS. 100, 101 AND 107).  
FIRST USE 2-17-1998; IN COMMERCE 2-17-1998.

**CLASS 41—(Continued).**

3,942,167. GLOBAL SPECTRUM, L.P., PHILADELPHIA, PA. SN 85-043,538. PUB. 10-26-2010, FILED 5-20-2010.

**HOW YOU GROWIN'?**

THE MARK CONSISTS OF STANDARD CHARACTERS WITHOUT CLAIM TO ANY PARTICULAR FONT, STYLE, SIZE, OR COLOR.

FOR EDUCATIONAL SERVICES, NAMELY, COURSES, SEMINARS, AND PRESENTATIONS IN THE AREA OF CAREER DEVELOPMENT; CAREER DEVELOPMENT SERVICES, NAMELY, CAREER COUNSELING (U.S. CLS. 100, 101 AND 107).

FIRST USE 3-0-2010; IN COMMERCE 6-0-2010.

3,942,168. GLOBAL SPECTRUM, L.P., PHILADELPHIA, PA. SN 85-043,545. PUB. 10-26-2010, FILED 5-20-2010.



THE MARK CONSISTS OF THE WORDING "HOW YOU GROWIN'?" IN STYLIZED LETTERING, WITH THE WORDING "HOW YOU" BEING FOLLOWED BY AN IMAGE OF A PERSON WITH A BRIEFCASE ABOVE THE WORDING "GROWIN'?" WITH A NARROW BAND BELOW THE WORDING "GROWIN'?".

FOR EDUCATIONAL SERVICES, NAMELY, COURSES, SEMINARS, AND PRESENTATIONS IN THE AREA OF CAREER DEVELOPMENT; CAREER DEVELOPMENT SERVICES, NAMELY, CAREER COUNSELING (U.S. CLS. 100, 101 AND 107).

FIRST USE 3-0-2010; IN COMMERCE 6-0-2010.

3,942,170. LOCAL MUZ, LLC, SOUTH LYME, CT. SN 85-043,685. PUB. 10-19-2010, FILED 5-20-2010.

**BRING OUR MUSIC BACK**

THE MARK CONSISTS OF STANDARD CHARACTERS WITHOUT CLAIM TO ANY PARTICULAR FONT, STYLE, SIZE, OR COLOR.

FOR ENTERTAINMENT SERVICES, NAMELY, PROVIDING A WEBSITE FEATURING INFORMATION AND NEWS RELEASES ABOUT MUSICAL ARTISTS VIA GLOBAL COMMUNICATIONS NETWORKS (U.S. CLS. 100, 101 AND 107).

FIRST USE 5-20-2009; IN COMMERCE 5-20-2009.

**CLASS 41—(Continued).**

3,942,185. PESCE VITA, LYNN, YONKERS, NY. SN 85-046,817. PUB. 10-26-2010, FILED 5-24-2010.

**SCHOOLYARDFIT**

THE MARK CONSISTS OF STANDARD CHARACTERS WITHOUT CLAIM TO ANY PARTICULAR FONT, STYLE, SIZE, OR COLOR.

FOR PHYSICAL FITNESS CONDITIONING CLASSES (U.S. CLS. 100, 101 AND 107).

FIRST USE 7-1-2010; IN COMMERCE 7-1-2010.

3,942,203. THE SERVICE DOG INSTITUTE OF SOUTH CAROLINA, SIMPSONVILLE, SC. SN 85-051,026. PUB. 10-26-2010, FILED 5-30-2010.



THE MARK CONSISTS OF A STYLIZED DESIGN OF A BUILDING.

FOR ANIMAL TRAINING SERVICES, NAMELY, TRAINING SERVICE ANIMALS FOR USE BY PERSONS WITH SPECIAL NEEDS AND DISABILITIES; EDUCATIONAL SERVICES, NAMELY, DEVELOPING AND CONDUCTING EDUCATIONAL CLASSES, SEMINARS AND WORKSHOPS IN THE FIELD OF ANIMAL TRAINING AND SERVICE ANIMALS FOR PERSONS WITH SPECIAL NEEDS AND DISABILITIES, AND DISTRIBUTION OF PRINTED MATERIALS IN CONNECTION THEREWITH; PROVIDING INFORMATION IN THE FIELD OF ANIMAL TRAINING SERVICES FOR PERSONS WITH SPECIAL NEEDS AND DISABILITIES (U.S. CLS. 100, 101 AND 107).

FIRST USE 7-0-2010; IN COMMERCE 7-0-2010.



**CLASS 41—(Continued).**

3,942,211. NATIONAL MARROW DONOR PROGRAM, MINNEAPOLIS, MN. SN 85-052,016. PUB. 11-2-2010, FILED 6-1-2010.



OWNER OF U.S. REG. NOS. 3,636,624, 3,785,729, AND OTHERS.

NO CLAIM IS MADE TO THE EXCLUSIVE RIGHT TO USE "RUN", APART FROM THE MARK AS SHOWN.

THE MARK CONSISTS OF THE WORDS "BE THE MATCH". THE DESIGN ELEMENTS OF FOUR CIRCLES WITH THE COLOR BLACK WITHIN EACH CIRCLE IS BETWEEN THE WORDS "BE" AND "THE". "BE THE MATCH" ALONG WITH THE DESIGN ELEMENT ARE WITHIN A WHITE RECTANGLE. THE WORDS "BE THE ONE RUN" IS WITHIN A BLACK RECTANGLE. THREE LINES THAT FADE FROM BLACK TO WHITE APPEAR TO THE LOWER LEFT OF THE BLACK RECTANGLE.

FOR ATHLETIC AND SPORTS EVENTS SERVICES, NAMELY, ARRANGING, ORGANIZING, OPERATING AND CONDUCTING RUNNING RACES (U.S. CLS. 100, 101 AND 107).

FIRST USE 7-1-2010; IN COMMERCE 7-1-2010.

---

3,942,224. MUTUAL CAPITAL ALLIANCE, INC., DALLAS, TX. SN 85-054,377. PUB. 11-9-2010, FILED 6-3-2010.

## Catalyzing Statement

THE MARK CONSISTS OF STANDARD CHARACTERS WITHOUT CLAIM TO ANY PARTICULAR FONT, STYLE, SIZE, OR COLOR.

NO CLAIM IS MADE TO THE EXCLUSIVE RIGHT TO USE "STATEMENT", APART FROM THE MARK AS SHOWN.

FOR EDUCATIONAL AND ENTERTAINMENT SERVICES, NAMELY, PROVIDING MOTIVATIONAL SPEAKING SERVICES IN THE FIELD OF USING KEY STATEMENTS TO MOTIVATE OTHERS (U.S. CLS. 100, 101 AND 107).

FIRST USE 4-5-2005; IN COMMERCE 3-24-2010.

**CLASS 41—(Continued).**

3,942,239. AMERICAN SECURITY COUNCIL FOUNDATION, SEBASTIAN, FL. SN 85-061,044. PUB. 11-9-2010, FILED 6-11-2010.

## PEACE THROUGH STRENGTH

THE MARK CONSISTS OF STANDARD CHARACTERS WITHOUT CLAIM TO ANY PARTICULAR FONT, STYLE, SIZE, OR COLOR.

FOR EDUCATION SERVICES, NAMELY, PROVIDING PROGRAMS IN THE FIELD OF CRITICAL CHALLENGES TO U.S. FOREIGN POLICY, NATIONAL SECURITY AND THE GLOBAL ECONOMY (U.S. CLS. 100, 101 AND 107).

FIRST USE 5-1-1958; IN COMMERCE 1-10-1959.

---

3,942,250. NSC PARTNERS LLC, LAHAINA, HI. SN 85-064,695. PUB. 11-16-2010, FILED 6-16-2010.

## Winning Sports Advice

THE MARK CONSISTS OF STANDARD CHARACTERS WITHOUT CLAIM TO ANY PARTICULAR FONT, STYLE, SIZE, OR COLOR.

NO CLAIM IS MADE TO THE EXCLUSIVE RIGHT TO USE "SPORTS ADVICE", APART FROM THE MARK AS SHOWN.

FOR ENTERTAINMENT AND EDUCATIONAL SERVICES IN THE NATURE OF ON-LINE COMPETITIONS IN THE FIELD OF ENTERTAINMENT, EDUCATION, CULTURE, SPORTS, AND OTHER NON-BUSINESS AND NON-COMMERCIAL FIELDS; ENTERTAINMENT SERVICES, NAMELY, PROVIDING NEWS AND INFORMATION IN THE FIELD OF SPORTS GAMES; ENTERTAINMENT SERVICES, NAMELY, PROVIDING ON-LINE REVIEWS OF UPCOMING SPORTS GAMES; HANDICAPPING FOR SPORTING EVENTS (U.S. CLS. 100, 101 AND 107).

FIRST USE 2-19-2010; IN COMMERCE 9-18-2010.

---

3,942,275. INFO MARKETING INC., MIAMI BEACH, FL. SN 85-072,900. PUB. 11-23-2010, FILED 6-28-2010.

## ENTREPRENEUR'S PATH

THE MARK CONSISTS OF STANDARD CHARACTERS WITHOUT CLAIM TO ANY PARTICULAR FONT, STYLE, SIZE, OR COLOR.

**CLASS 41—(Continued).**

NO CLAIM IS MADE TO THE EXCLUSIVE RIGHT TO USE "ENTREPRENEUR'S", APART FROM THE MARK AS SHOWN.

FOR EDUCATION SERVICES FOR ENTREPRENEURS, NAMELY, PROVIDING WORKSHOPS AND SEMINARS IN THE FIELDS OF BUSINESS AND MARKETING; EDUCATIONAL SERVICES, NAMELY, PROVIDING ONLINE TUTORIALS IN THE FIELD OF BUSINESS AND MARKETING; PROFESSIONAL COACHING SERVICES IN THE FIELD OF BUSINESS AND MARKETING; PROVIDING ON-LINE NEWSLETTERS IN THE FIELD OF BUSINESS AND MARKETING (U.S. CLS. 100, 101 AND 107).

FIRST USE 1-0-2010; IN COMMERCE 6-0-2010.

---

3,942,310. HAM, IRA, SANTA ANA, CA. SN 85-085,912. PUB. 12-14-2010, FILED 7-15-2010.

## WYRD CON

THE MARK CONSISTS OF STANDARD CHARACTERS WITHOUT CLAIM TO ANY PARTICULAR FONT, STYLE, SIZE, OR COLOR.

NO CLAIM IS MADE TO THE EXCLUSIVE RIGHT TO USE "CON", APART FROM THE MARK AS SHOWN.

FOR ENTERTAINMENT IN THE NATURE OF THEATER PRODUCTIONS, STILL PHOTOGRAPHY PRODUCTIONS, AND VIDEO PRODUCTIONS, ALL INVOLVING LIVE ACTION ROLE PLAY; EDUCATION AND ENTERTAINMENT SERVICES, NAMELY, ORGANIZING AND CONDUCTING CONVENTIONS IN THE FIELDS OF LIVE ACTION ROLE PLAY AND THEATRICAL PERFORMANCES (U.S. CLS. 100, 101 AND 107).

FIRST USE 11-1-2009; IN COMMERCE 6-11-2010.

---

3,942,320. WEIGHT WATCHERS INTERNATIONAL, INC., NEW YORK, NY. SN 85-103,802. PUB. 11-30-2010, FILED 8-10-2010.

## A CUT ABOVE

THE MARK CONSISTS OF STANDARD CHARACTERS WITHOUT CLAIM TO ANY PARTICULAR FONT, STYLE, SIZE, OR COLOR.

FOR PROVIDING AN ONLINE COLUMN FEATURING RECIPES AND IDEAS RELATING TO FOOD AND COOKING (U.S. CLS. 100, 101 AND 107).

FIRST USE 8-31-2010; IN COMMERCE 8-31-2010.

**CLASS 41—(Continued).**

3,942,321. MUTUAL CAPITAL ALLIANCE, INC., DALLAS, TX. SN 85-104,096. PUB. 11-16-2010, FILED 8-10-2010.

## Addicted to Yes

THE MARK CONSISTS OF STANDARD CHARACTERS WITHOUT CLAIM TO ANY PARTICULAR FONT, STYLE, SIZE, OR COLOR.

NO CLAIM IS MADE TO THE EXCLUSIVE RIGHT TO USE "YES", APART FROM THE MARK AS SHOWN.

FOR EDUCATIONAL AND ENTERTAINMENT SERVICES, NAMELY, PROVIDING MOTIVATIONAL SPEAKING SERVICES THAT GOES OVER AND TEACHES PEOPLE HOW TO GET OVER BEING SO BUSY SAYING YES, THEY CAN'T ENJOY LIFE (U.S. CLS. 100, 101 AND 107).

FIRST USE 4-1-2005; IN COMMERCE 3-24-2010.

---

3,942,322. MUTUAL CAPITAL ALLIANCE, INC., DALLAS, TX. SN 85-104,108. PUB. 11-2-2010, FILED 8-10-2010.

## Doorman Principle

THE MARK CONSISTS OF STANDARD CHARACTERS WITHOUT CLAIM TO ANY PARTICULAR FONT, STYLE, SIZE, OR COLOR.

NO CLAIM IS MADE TO THE EXCLUSIVE RIGHT TO USE "PRINCIPLE", APART FROM THE MARK AS SHOWN.

FOR EDUCATIONAL AND ENTERTAINMENT SERVICES, NAMELY, PROVIDING MOTIVATIONAL SPEAKING SERVICES ON HOW TO KEEP NEGATIVE PEOPLE AND NEGATIVE SITUATIONS OUT OF THEIR LIVES (U.S. CLS. 100, 101 AND 107).

FIRST USE 4-1-2005; IN COMMERCE 3-21-2010.

**CLASS 42—SCIENTIFIC AND COMPUTER SERVICES**

3,940,993. MATCH POINT CAREERS, INC., NEW YORK, NY. SN 76-700,032. PUB. 8-10-2010, FILED 10-22-2009.

## Matchpoint Careers

THE MARK CONSISTS OF STANDARD CHARACTERS WITHOUT CLAIM TO ANY PARTICULAR FONT, STYLE, SIZE, OR COLOR.

NO CLAIM IS MADE TO THE EXCLUSIVE RIGHT TO USE "CAREERS", APART FROM THE MARK AS SHOWN.

FOR COMPUTER SERVICES, NAMELY, HOSTING ONLINE WEB FACILITIES FOR ORGANIZING JOB APPLICANTS AND EMPLOYERS, AND INTERACTIVE DISCUSSIONS (U.S. CLS. 100 AND 101).

FIRST USE 1-1-2011; IN COMMERCE 1-1-2011.

**CLASS 42—(Continued).**

3,941,026. PHASERX, INC., SEATTLE, WA. SN 77-188,314. PUB. 11-20-2007, FILED 5-23-2007.

# PHASERX

THE MARK CONSISTS OF STANDARD CHARACTERS WITHOUT CLAIM TO ANY PARTICULAR FONT, STYLE, SIZE, OR COLOR.

FOR DEVELOPMENT OF NEW TECHNOLOGY FOR OTHERS IN THE FIELD OF BIOTECHNOLOGY (U.S. CLS. 100 AND 101).

FIRST USE 3-1-2008; IN COMMERCE 3-1-2008.

3,941,055. YAHOO! INC., SUNNYVALE, CA. SN 77-332,188. PUB. 5-6-2008, FILED 11-16-2007.

# CITIZEN SPORTS

THE MARK CONSISTS OF STANDARD CHARACTERS WITHOUT CLAIM TO ANY PARTICULAR FONT, STYLE, SIZE, OR COLOR.

NO CLAIM IS MADE TO THE EXCLUSIVE RIGHT TO USE "SPORTS", APART FROM THE MARK AS SHOWN.

FOR PROVIDING A WEBSITE THAT GIVES COMPUTER USERS THE ABILITY TO UPLOAD, EXCHANGE AND SHARE PHOTOS, VIDEOS AND VIDEO LOGS (U.S. CLS. 100 AND 101).

FIRST USE 6-25-2008; IN COMMERCE 6-25-2008.

3,941,057. HELENA HOLDING COMPANY, WILMINGTON, DE. SN 77-335,353. PUB. 10-21-2008, FILED 11-21-2007.

# SMART ACRE

THE MARK CONSISTS OF STANDARD CHARACTERS WITHOUT CLAIM TO ANY PARTICULAR FONT, STYLE, SIZE, OR COLOR.

FOR CONSULTATION SERVICES IN THE FIELD OF AGRICULTURE (U.S. CLS. 100 AND 101).

FIRST USE 2-22-2008; IN COMMERCE 2-22-2008.

**CLASS 42—(Continued).**

3,941,058. YUREEKAH, INC., FORMERLY YUREEKAH LLC, NEW YORK, NY. SN 77-348,930. PUB. 8-19-2008, FILED 12-11-2007.



THE COLOR(S) GREEN AND BLACK IS/ARE CLAIMED AS A FEATURE OF THE MARK.

THE ELEMENT COMPRISING "(!)" IS PRESENTED IN GREEN, AS ARE THE TWO LETTER "E'S". THE REMAINDER OF THE MARK IS IN BLACK.

FOR PROVIDING SEARCH ENGINES FOR OBTAINING AND PROVIDING DATA ON A GLOBAL COMPUTER NETWORK, RELATING TO COMPUTERS AND TECHNOLOGY (U.S. CLS. 100 AND 101).

FIRST USE 11-10-2009; IN COMMERCE 11-10-2009.

3,941,127. INTERNATIONAL EROSION CONTROL ASSOCIATION, DENVER, CO. SN 77-557,391. PUB. 7-14-2009, FILED 8-27-2008.

# IECA-CEU

THE MARK CONSISTS OF STANDARD CHARACTERS WITHOUT CLAIM TO ANY PARTICULAR FONT, STYLE, SIZE, OR COLOR.

OWNER OF U.S. REG. NOS. 2,156,776 AND 2,869,962.

FOR ACCREDITATION SERVICES, NAMELY, EVALUATING EDUCATIONAL ORGANIZATIONS TO DETERMINE WHETHER THE ORGANIZATIONS CONFORM TO AN ESTABLISHED STANDARD (U.S. CLS. 100 AND 101).

FIRST USE 4-1-2010; IN COMMERCE 11-8-2010.

3,941,173. LAUREATE EDUCATION, INC., BALTIMORE, MD. SN 77-631,135. PUB. 8-31-2010, FILED 12-11-2008.

# MobileLearn

THE MARK CONSISTS OF STANDARD CHARACTERS WITHOUT CLAIM TO ANY PARTICULAR FONT, STYLE, SIZE, OR COLOR.

FOR PROVIDING ON-LINE NON-DOWNLOADABLE SOFTWARE FOR PERFORMING DIGITAL RIGHTS MANAGEMENT FUNCTIONS, NAMELY, FOR PROVIDING OTHERS WITH AUTHORIZED ACCESS TO DIGITAL COURSEWORK AND COURSE CONTENT CONTAINED IN PROPRIETARY DATABASES AND FILES (U.S. CLS. 100 AND 101).

FIRST USE 1-31-2011; IN COMMERCE 1-31-2011.

**CLASS 42—(Continued).**

3,941,201. MISSION PHARMACAL COMPANY, SAN ANTONIO, TX. SN 77-652,416. PUB. 4-21-2009, FILED 1-20-2009.



THE MARK CONSISTS OF A LOWER CASE "B" AND "P" CONNECTED WITH ONE AN ARC THAT IS THE LETTER "C".

FOR DEVELOPMENT OF PHARMACEUTICAL AND DIETARY SUPPLEMENT PRODUCTS (U.S. CLS. 100 AND 101).

FIRST USE 1-0-2009; IN COMMERCE 1-0-2009.

3,941,234. MARCHIONE, DAMIAN, PLANTATION, FL. SN 77-683,689. PUB. 6-30-2009, FILED 3-4-2009.

## ANIMINGLE

THE MARK CONSISTS OF STANDARD CHARACTERS WITHOUT CLAIM TO ANY PARTICULAR FONT, STYLE, SIZE, OR COLOR.

FOR COMPUTER SERVICES, NAMELY, CREATING AN ON-LINE COMMUNITY FOR REGISTERED USERS TO PARTICIPATE IN COMPETITIONS, SHOWCASE THEIR SKILLS, GET FEEDBACK FROM THEIR PEERS, FORM VIRTUAL COMMUNITIES, ENGAGE IN SOCIAL NETWORKING AND IMPROVE THEIR TALENT; COMPUTER SERVICES, NAMELY, CREATING AN ON-LINE COMMUNITY FOR REGISTERED USERS TO PARTICIPATE IN DISCUSSIONS, GET FEEDBACK FROM THEIR PEERS, FORM VIRTUAL COMMUNITIES, AND ENGAGE IN SOCIAL NETWORKING; COMPUTER SERVICES, NAMELY, HOSTING AND MAINTAINING AN ON-LINE WEB SITE FOR OTHERS TO ORGANIZE AND CONDUCT ONLINE MEETINGS, GATHERINGS, AND INTERACTIVE DISCUSSIONS; AND COMPUTER SERVICES IN THE NATURE OF CUSTOMIZED WEB PAGES FEATURING USER-DEFINED INFORMATION, PERSONAL PROFILES AND INFORMATION (U.S. CLS. 100 AND 101).

FIRST USE 7-25-2007; IN COMMERCE 7-25-2007.

**CLASS 42—(Continued).**

3,941,238. EMC CORPORATION, HOPKINTON, MA. SN 77-685,624. PUB. 11-24-2009, FILED 3-6-2009.

## VBLOCK

THE MARK CONSISTS OF STANDARD CHARACTERS WITHOUT CLAIM TO ANY PARTICULAR FONT, STYLE, SIZE, OR COLOR.

FOR COMPUTER SERVICES, NAMELY, COMPUTER CONSULTATION, CUSTOMIZATION OF COMPUTER HARDWARE AND SOFTWARE, COMPUTER HARDWARE AND SOFTWARE DESIGN AND DEVELOPMENT, DEPLOYMENT AND INSTALLATION OF COMPUTER SOFTWARE (U.S. CLS. 100 AND 101).

FIRST USE 11-3-2009; IN COMMERCE 11-3-2009.

3,941,261. ASHLAR MEDICAL, L.L.C., NATCHITOCHE, LA. SN 77-722,670. PUB. 12-8-2009, FILED 4-27-2009.

## Ashlar Holdings

THE MARK CONSISTS OF STANDARD CHARACTERS WITHOUT CLAIM TO ANY PARTICULAR FONT, STYLE, SIZE, OR COLOR.

NO CLAIM IS MADE TO THE EXCLUSIVE RIGHT TO USE "HOLDINGS", APART FROM THE MARK AS SHOWN. FOR DEVELOPMENT AND DESIGN OF NEW TECHNOLOGY AND EQUIPMENT FOR THE MEDICAL INDUSTRY (U.S. CLS. 100 AND 101).

FIRST USE 1-6-2006; IN COMMERCE 1-6-2006.

3,941,275. MINEKEY, INC., SUNNYVALE, CA. SN 77-739,831. PUB. 11-3-2009, FILED 5-18-2009.

## Tweezr

THE MARK CONSISTS OF STANDARD CHARACTERS WITHOUT CLAIM TO ANY PARTICULAR FONT, STYLE, SIZE, OR COLOR.

FOR PROVIDING COMPUTER SERVICES, NAMELY, SEARCHING AND RETRIEVING INFORMATION, SITES AND OTHER RESOURCES AVAILABLE ON COMPUTER NETWORKS FOR OTHERS AND DATA MINING BY MEANS OF COMPUTER NETWORKS (U.S. CLS. 100 AND 101).

FIRST USE 8-1-2010; IN COMMERCE 12-1-2010.

**CLASS 42—(Continued).**

3,941,285. HARTFORD FIRE INSURANCE COMPANY, HARTFORD, CT. SN 77-752,227. PUB. 11-24-2009, FILED 6-4-2009.

**CLASS 42—(Continued).**

3,941,413. HEARTLAND PAYMENT SYSTEMS, INC., PRINCETON, NJ. SN 77-801,585. PUB. 6-22-2010, FILED 8-11-2009.

**HartSCORE**

**HEARTLAND**

THE MARK CONSISTS OF STANDARD CHARACTERS WITHOUT CLAIM TO ANY PARTICULAR FONT, STYLE, SIZE, OR COLOR.

FOR PROVIDING TEMPORARY USE OF AN ONLINE NON-DOWNLOADABLE COMPUTER SOFTWARE FOR QUOTING AND ISSUING COMMERCIAL LINES BUSINESS, NAMELY, PROPERTY, GENERAL LIABILITY, COMMERCIAL AUTO, WORKERS' COMPENSATION AND PACKAGE BUSINESS (U.S. CLS. 100 AND 101).

FIRST USE 10-13-2010; IN COMMERCE 10-13-2010.

THE MARK CONSISTS OF STANDARD CHARACTERS WITHOUT CLAIM TO ANY PARTICULAR FONT, STYLE, SIZE, OR COLOR.

OWNER OF U.S. REG. NOS. 2,742,163, 3,315,693, AND OTHERS.

FOR DATA ENCRYPTION SERVICES IN THE FIELD OF PAYMENT CARD PROCESSING; PROVIDING TEMPORARY ONLINE NON-DOWNLOADABLE COMPUTER SOFTWARE FOR USE IN ACCESSING ONLINE CREDIT, DEBIT, BANK CARD, SMART CARD AND PAYMENT CARD TRANSACTION PROCESSING SERVICES; COMPUTER SERVICES, NAMELY, PROVIDING TEMPORARY USE OF NON-DOWNLOADABLE COMPUTER SOFTWARE FOR PROVIDING A WEB-BASED SCHOOL MANAGEMENT SYSTEM AND ONLINE PORTAL FOR PROVIDING FINANCIAL MANAGEMENT, ADMISSIONS MANAGEMENT, EDUCATION MANAGEMENT AND RECORDS MANAGEMENT (U.S. CLS. 100 AND 101).

FIRST USE 6-30-2009; IN COMMERCE 6-30-2009.

3,941,321. AUTO CRUISE AMERICA LLC, BEDMINSTER, PA. SN 77-765,281. PUB. 6-1-2010, FILED 6-22-2009.

3,941,433. SATELLITE LOGISTICS GROUP, INC., HOUSTON, TX. SN 77-808,990. PUB. 6-1-2010, FILED 8-20-2009.

**AUTO CRUISE AMERICA**

**LogiTrax**

THE MARK CONSISTS OF STANDARD CHARACTERS WITHOUT CLAIM TO ANY PARTICULAR FONT, STYLE, SIZE, OR COLOR.

NO CLAIM IS MADE TO THE EXCLUSIVE RIGHT TO USE "AUTO" AND "AMERICA", APART FROM THE MARK AS SHOWN.

FOR COMPUTER SERVICES, NAMELY, CREATING AN ON-LINE COMMUNITY FOR REGISTERED USERS TO PARTICIPATE IN DISCUSSIONS, GET FEEDBACK FROM THEIR PEERS, FORM VIRTUAL COMMUNITIES, AND ENGAGE IN SOCIAL NETWORKING; HOSTING AN ON-LINE COMMUNITY WEB SITE FOR AUTOMOBILE ENTHUSIASTS FEATURING AUTOMOBILE RELATED PHOTO AND VIDEO SHARING, DISCUSSION FORUMS, AN ON-LINE SWAP MEET FOR CARS AND CAR PARTS, AND INFORMATION ABOUT AUTO CLUBS, AUCTIONS, AUTO SHOWS, AND THE LIKE (U.S. CLS. 100 AND 101).

FIRST USE 1-20-2011; IN COMMERCE 1-20-2011.

THE MARK CONSISTS OF STANDARD CHARACTERS WITHOUT CLAIM TO ANY PARTICULAR FONT, STYLE, SIZE, OR COLOR.

FOR PROVIDING A WEBSITE FEATURING TECHNOLOGY THAT ENABLES BUSINESS-TO-BUSINESS COMMERCIAL SHIPPERS TO REQUEST, VIEW, AND MANAGE TRANSPORTATION AND DISTRIBUTION OF GOODS (U.S. CLS. 100 AND 101).

FIRST USE 9-18-2009; IN COMMERCE 9-18-2009.

**CLASS 42—(Continued).**

3,941,511. THE AMERICAN INSTITUTE OF ARCHITECTS, WASHINGTON, DC. SN 77-855,175. PUB. 9-14-2010, FILED 10-22-2009.

AIA DOCUMENTS ON DEMAND

THE MARK CONSISTS OF STANDARD CHARACTERS WITHOUT CLAIM TO ANY PARTICULAR FONT, STYLE, SIZE, OR COLOR.

OWNER OF U.S. REG. NOS. 789,363, 793,832, AND OTHERS.

NO CLAIM IS MADE TO THE EXCLUSIVE RIGHT TO USE "DOCUMENTS ON DEMAND", APART FROM THE MARK AS SHOWN.

FOR PROVIDING A WEBSITE FEATURING ON-LINE NON-DOWNLOADABLE SOFTWARE TOOLS FOR CONTRACT PREPARATION (U.S. CLS. 100 AND 101).

FIRST USE 10-18-2009; IN COMMERCE 10-15-2010.

3,941,542. EMC CORPORATION, HOPKINTON, MA. SN 77-866,726. PUB. 3-30-2010, FILED 11-6-2009.

**VPLEX**

THE MARK CONSISTS OF STANDARD CHARACTERS WITHOUT CLAIM TO ANY PARTICULAR FONT, STYLE, SIZE, OR COLOR.

FOR COMPUTER SERVICES, NAMELY, COMPUTER CONSULTATION, CUSTOMIZATION OF COMPUTER HARDWARE AND SOFTWARE, COMPUTER HARDWARE AND SOFTWARE DESIGN AND DEVELOPMENT, DEPLOYMENT AND INSTALLATION OF COMPUTER SOFTWARE (U.S. CLS. 100 AND 101).

FIRST USE 5-10-2010; IN COMMERCE 5-10-2010.

**CLASS 42—(Continued).**

3,941,547. GL SUITE, INC., BEND, OR. SN 77-868,585. PUB. 4-20-2010, FILED 11-9-2009.

glsimple 

THE MARK CONSISTS OF THE TERM "GL SIMPLE" WITH A CIRCLE DESIGN.

FOR COMPUTER HARDWARE AND SOFTWARE CONSULTATION IN THE FIELD OF REGULATORY COMPUTER SYSTEMS; DESIGN AND DEVELOPMENT OF SOFTWARE THAT PROVIDE REGULATORY AND CASE MANAGEMENT, BEST PRACTICES INFORMATION, ON-LINE RENEWALS FOR GOVERNMENT, FOR-PROFIT COMPANIES, NOT-FOR-PROFIT ENTITIES AND EDUCATIONAL ENTITIES THAT ISSUE CERTIFICATIONS, LICENSES AND REGISTRATIONS; TECHNICAL SUPPORT SERVICES, NAMELY, 24/7 SERVICE DESK/HELP DESK SERVICES FOR IT INFRASTRUCTURE, OPERATING SYSTEMS, DATABASE SYSTEMS, AND WEB APPLICATIONS (U.S. CLS. 100 AND 101).

FIRST USE 3-19-2010; IN COMMERCE 3-19-2010.

3,941,552. CHILEI, LLC, ELLSWORTH, WI. SN 77-871,388. PUB. 6-8-2010, FILED 11-12-2009.

**CHILEI**

THE MARK CONSISTS OF STANDARD CHARACTERS WITHOUT CLAIM TO ANY PARTICULAR FONT, STYLE, SIZE, OR COLOR.

FOR GRAPHIC DESIGN SERVICES; GRAPHIC ART STUDIO SERVICES, NAMELY, GRAPHIC ART DESIGN AND GRAPHIC ILLUSTRATION SERVICES FOR OTHERS; DESIGN OF TEXTILES; FOOTWEAR DESIGN SERVICES; GRAPHIC ART DESIGN; GRAPHIC ARTS DESIGNING; PROVIDING GRAPHIC AND MULTIMEDIA DESIGN SERVICES FOR THE PURPOSE OF PROMOTING THE GOODS AND SERVICES OF OTHERS; MULTIDISCIPLINARY GRAPHIC DESIGN SERVICES; PACKAGE AND PRODUCT DESIGN FOR OTHERS; GRAPHIC ILLUSTRATION SERVICES FOR OTHERS; DESIGN SERVICES FOR PACKAGING; NEW PRODUCT DESIGN SERVICES (U.S. CLS. 100 AND 101).

FIRST USE 8-28-2010; IN COMMERCE 8-28-2010.

**CLASS 42—(Continued).**

3,941,576. REPAIRSTADT, INC., SWAMPSCOTT, MA. SN 77-877,615. PUB. 4-27-2010, FILED 11-20-2009.



THE MARK CONSISTS OF THE WORDING "REPAIRSTADT PROTECTING YOU FOR PEACE OF MIND" AND TWO OVERLAPPING DIAMOND SHAPED DESIGNS.

FOR CONSULTING IN THE FIELD OF INFORMATION TECHNOLOGY; TECHNICAL SUPPORT SERVICES, NAMELY, TROUBLESHOOTING IN THE NATURE OF DIAGNOSING COMPUTER HARDWARE AND SOFTWARE PROBLEMS (U.S. CLS. 100 AND 101).  
FIRST USE 11-1-2009; IN COMMERCE 11-1-2009.

3,941,584. AUTOMATTIC INC., SAN FRANCISCO, CA. SN 77-879,105. PUB. 6-1-2010, FILED 11-23-2009.

## BUDDYPRESS

THE MARK CONSISTS OF STANDARD CHARACTERS WITHOUT CLAIM TO ANY PARTICULAR FONT, STYLE, SIZE, OR COLOR.

OWNER OF U.S. REG. NOS. 3,201,424 AND 3,201,428.  
FOR PROVIDING ON-LINE NON-DOWNLOADABLE SOFTWARE FOR USE IN ENABLING INTERNET PUBLISHING (U.S. CLS. 100 AND 101).  
FIRST USE 12-15-2008; IN COMMERCE 12-15-2008.

3,941,705. ITON CORPORATION., MISSISSAUGA, ONTARIO, CANADA. SN 77-902,661. PUB. 6-15-2010, FILED 12-30-2009.

## Super Human Platform

THE MARK CONSISTS OF STANDARD CHARACTERS WITHOUT CLAIM TO ANY PARTICULAR FONT, STYLE, SIZE, OR COLOR.

**CLASS 42—(Continued).**

NO CLAIM IS MADE TO THE EXCLUSIVE RIGHT TO USE "PLATFORM", APART FROM THE MARK AS SHOWN.

FOR INTERNET BASED SOFTWARE, NAMELY, PROVIDING ON-LINE NON-DOWNLOADABLE SOFTWARE THAT ALLOWS WEB-BASED ACCESS TO APPLICATIONS OVER THE INTERNET; PROVIDING ONLINE NON-DOWNLOADABLE INTERNET BASED APPLICATIONS FOR ACCESSING AND USING A CLOUD-COMPUTING NETWORK TO SUBSCRIBERS IN ASSOCIATION WITH A SPECIFIC PROVIDER AND HOSTING PROVIDERS; ONLINE NON-DOWNLOADABLE SOFTWARE TO ENABLE SUBSCRIBERS TO ACCESS AND EXCHANGE INFORMATION AND COMMUNICATION, NAMELY, VIDEO CLIPS, AUDIO OBJECTS, EMAILS, FAXES, ELECTRONIC FORMS, ELECTRONIC DOCUMENTS, IMAGES, SMS (SHORT MESSAGING SERVICE), AND MMS (MULTIMEDIA MESSAGING SERVICE) WITH OTHER SUBSCRIBERS VIA A GLOBAL CLOUD COMPUTER NETWORK (U.S. CLS. 100 AND 101).

FIRST USE 9-0-2010; IN COMMERCE 9-0-2010.

3,941,768. BROSS, RICHARD A., DBA SILVERSPORE.COM, HOLLIS, NH. SN 77-913,622. PUB. 6-1-2010, FILED 1-17-2010.

## SilverSpore

THE MARK CONSISTS OF STANDARD CHARACTERS WITHOUT CLAIM TO ANY PARTICULAR FONT, STYLE, SIZE, OR COLOR.

FOR SOFTWARE AS A SERVICE (SAAS) SERVICES FEATURING SOFTWARE IN THE FIELD OF IT, SYSTEMS, AND NETWORK MANAGEMENT (U.S. CLS. 100 AND 101).

FIRST USE 5-21-2010; IN COMMERCE 9-2-2010.

3,941,796. INTERJACENT TECHNOLOGY SYSTEMS, INC., CORRALITOS, CA. SN 77-918,575. PUB. 6-15-2010, FILED 1-22-2010.

## WHAT'S THAT

THE MARK CONSISTS OF STANDARD CHARACTERS WITHOUT CLAIM TO ANY PARTICULAR FONT, STYLE, SIZE, OR COLOR.

FOR COMPUTING SERVICES, NAMELY, PROVIDING TEMPORARY USE OF ONLINE NON-DOWNLOADABLE COMPUTER SOFTWARE FOR INTEGRATING GEOLOCATION DATA AND INFORMATION ABOUT PLACES OF INTEREST (U.S. CLS. 100 AND 101).

FIRST USE 1-18-2011; IN COMMERCE 1-18-2010.

**CLASS 42—(Continued).**

3,941,800. PAR TECHNOLOGY CORPORATION, NEW HARTFORD, NY. SN 77-919,002. PUB. 6-15-2010, FILED 1-25-2010.



OWNER OF U.S. REG. NO. 3,686,108.  
NO CLAIM IS MADE TO THE EXCLUSIVE RIGHT TO USE "RETAILING", APART FROM THE MARK AS SHOWN. THE MARK CONSISTS OF A SERIES OF THREE ROWS OF DOTS EACH INCREASING LIGHTLY IN DIAMETER FROM THE BOTTOM TOWARDS THE TOP AND ALL OF WHICH ARE POSITIONED TO THE LEFT OF THE WORDS "BOUNDLESS RETAILING BY PAR" AND WITH A PINEAPPLE TOP POSITIONED ADJACENT THE WORD "PAR".  
FOR TECHNICAL CONSULTING AND ASSISTANCE WITH COMPUTER-BASED INFORMATION SYSTEMS AND COMPONENTS (U.S. CLS. 100 AND 101).  
FIRST USE 2-0-2010; IN COMMERCE 2-0-2010.

---

3,941,824. CONCEPTUAL CALCULATIONS LLC, PETALUMA, CA. SN 77-921,210. PUB. 6-15-2010, FILED 1-27-2010.

## CONCEPTUA

---

THE MARK CONSISTS OF STANDARD CHARACTERS WITHOUT CLAIM TO ANY PARTICULAR FONT, STYLE, SIZE, OR COLOR.  
FOR PROVIDING TEMPORARY USE OF ON-LINE NON-DOWNLOADABLE SOFTWARE FOR TEACHING MATH TO GRADE SCHOOL STUDENTS (U.S. CLS. 100 AND 101).  
FIRST USE 11-25-2010; IN COMMERCE 11-24-2010.

---

3,941,894. BROWN, HOWARD J, GUILFORD, CT. SN 77-933,583. PUB. 8-3-2010, FILED 2-11-2010.

## DMASS

THE MARK CONSISTS OF STANDARD CHARACTERS WITHOUT CLAIM TO ANY PARTICULAR FONT, STYLE, SIZE, OR COLOR.  
FOR CONSULTING SERVICES IN ENVIRONMENTAL RESOURCE PLANNING AND ENVIRONMENTAL PLANNING TO REDUCE THE QUANTITY OF MATERIAL RESOURCES REQUIRED TO PRODUCE WEALTH AND TO SOLVE HUMAN PROBLEM (U.S. CLS. 100 AND 101).  
FIRST USE 10-25-2010; IN COMMERCE 12-14-2010.

**CLASS 42—(Continued).**

3,941,907. HEADHUNTER SYSTEMS, LTD., LONDON, UNITED KINGDOM. SN 77-937,463. PUB. 7-6-2010, FILED 2-17-2010.

## POSTMAT

THE MARK CONSISTS OF STANDARD CHARACTERS WITHOUT CLAIM TO ANY PARTICULAR FONT, STYLE, SIZE, OR COLOR.  
FOR PROVIDING TEMPORARY USE OF NON-DOWNLOADABLE SOFTWARE, IN THE FIELD OF EMPLOYMENT, ALLOWING LIVE VIDEO AND/OR AUDIO INTERVIEW SESSIONS TO BE HELD BETWEEN EMPLOYER AND POTENTIAL EMPLOYEE, AND FOR THE PROCESSING, ACCESSING AND STORING OF THE INTERVIEW AND RELATED CONTENT (U.S. CLS. 100 AND 101).  
FIRST USE 0-0-2010; IN COMMERCE 0-0-2010.

---

3,941,914. W. E. GUNDY & ASSOCIATES, INC., HAILEY, ID. SN 77-940,424. PUB. 7-13-2010, FILED 2-19-2010.

## WEGAI

THE MARK CONSISTS OF STANDARD CHARACTERS WITHOUT CLAIM TO ANY PARTICULAR FONT, STYLE, SIZE, OR COLOR.  
FOR ENGINEERING SERVICES, NAMELY, ENGINEERING FOR THE SEISMIC QUALIFICATION OF TRANSMISSION AND DISTRIBUTION EQUIPMENT (U.S. CLS. 100 AND 101).  
FIRST USE 3-12-2006; IN COMMERCE 3-12-2006.



**CLASS 42—(Continued).**

3,942,001. BATTELLE FOR KIDS, COLUMBUS, OH. SN 77-969,952. PUB. 8-17-2010, FILED 3-26-2010.

**BFK•Reflect**

THE MARK CONSISTS OF THE WORDS "BFK" REFLECT WITH A DOT BETWEEN THEM.

FOR PROVIDING TEMPORARY USE OF ON-LINE NON-DOWNLOADABLE SOFTWARE FOR USE IN THE EDUCATION FIELD BY EDUCATORS, SCHOOLS AND SCHOOL DISTRICTS, NAMELY, A COMPETING VALUES SURVEY INSTRUMENT, REPORTS AND NARRATIVES TO ASSESS TEACHING EFFECTIVENESS (U.S. CLS. 100 AND 101).

FIRST USE 3-26-2010; IN COMMERCE 12-15-2010.

3,942,002. ROOMATIONS LLC, CINCINNATI, OH. SN 77-970,026. PUB. 8-17-2010, FILED 3-26-2010.



THE COLOR(S) ORANGE AND GRAY IS/ARE CLAIMED AS A FEATURE OF THE MARK.

THE MARK CONSISTS OF THE WORD "ROOMATIONS" IN ORANGE AND, ABOVE THE WORD "ROOMATIONS", A GRAY SQUARE WITH ROUNDED CORNERS, AND ON THE LEFT SIDE OF THE SQUARE, THERE IS AN ORANGE DESIGN IN THE SHAPE OF A LOWERCASE "R".

FOR INTERIOR DESIGN SERVICES (U.S. CLS. 100 AND 101).

FIRST USE 1-20-2010; IN COMMERCE 10-21-2010.

**CLASS 42—(Continued).**

3,942,030. INTERNATIONAL BUSINESS MACHINES CORPORATION, ARMONK, NY. SN 77-981,289. PUB. 4-22-2008, FILED 4-10-2007.

**UC<sup>2</sup>**

THE MARK CONSISTS OF THE LETTERS "UC<sup>2</sup>" OR "UC" SQUARED.

FOR TECHNICAL SUPPORT SERVICES, NAMELY, TROUBLESHOOTING OF COMPUTER SOFTWARE PROBLEMS; COMPUTER SOFTWARE DESIGN FOR OTHERS; INSTALLATION, UPDATING AND MAINTENANCE OF COMPUTER SOFTWARE; CONSULTING SERVICES IN THE FIELD OF COMPUTER SOFTWARE (U.S. CLS. 100 AND 101).

FIRST USE 1-0-2007; IN COMMERCE 1-0-2007.

3,942,049. AGENCY.COM, LTD., NEW YORK, NY. SN 78-547,158. PUB. 4-4-2006, FILED 1-13-2005.

**IN AN INTERACTIVE WORLD  
YOU NEED AN AGENCY.COM**

OWNER OF U.S. REG. NO. 2,235,578.  
FOR WEBSITE DESIGN AND DEVELOPMENT SERVICES FOR OTHERS; CONDUCTING FEASIBILITY STUDIES (U.S. CLS. 100 AND 101).

FIRST USE 12-1-2004; IN COMMERCE 12-1-2004.

3,942,110. OLDCASTLE BUILDINGENVELOPE, INC., PLANO, TX. SN 85-016,134. PUB. 9-14-2010, FILED 4-16-2010.

**BIM IQ**

THE MARK CONSISTS OF STANDARD CHARACTERS WITHOUT CLAIM TO ANY PARTICULAR FONT, STYLE, SIZE, OR COLOR.

**CLASS 42—(Continued).**

NO CLAIM IS MADE TO THE EXCLUSIVE RIGHT TO USE "BIM", APART FROM THE MARK AS SHOWN.

FOR APPLICATION SERVICE PROVIDER (ASP) FEATURING SOFTWARE FOR USE IN DESIGN, SIMULATION, AND ENGINEERING OF BUILDINGS AND BUILDING COMPONENTS; CONSULTING IN THE FIELDS OF ENGINEERING AND ARCHITECTURE; AND GRAPHIC ILLUSTRATION AND DRAWING SERVICES, NAMELY, PROVIDING GRAPHIC ILLUSTRATIONS AND DRAWINGS OF COMMERCIAL AND INDUSTRIAL BUILDING DESIGNS, AND CONVERTING BUILDING DESIGNS OR MARKUPS TO ELECTRONIC CAD DRAWINGS (U.S. CLS. 100 AND 101).

FIRST USE 1-0-2011; IN COMMERCE 1-0-2011.

---

3,942,181. BEARDSWORTH CONSULTING GROUP, INC., FLEMINGTON, NJ. SN 85-046,362. PUB. 10-19-2010, FILED 5-24-2010.

**ONCOLOGYONE**

THE MARK CONSISTS OF STANDARD CHARACTERS WITHOUT CLAIM TO ANY PARTICULAR FONT, STYLE, SIZE, OR COLOR.

FOR CLINICAL RESEARCH SERVICES IN THE FIELDS OF PHARMACEUTICALS, BIOTECHNOLOGY AND MEDICAL DEVICES (U.S. CLS. 100 AND 101).

FIRST USE 4-30-2010; IN COMMERCE 4-30-2010.

---

3,942,199. BLX GROUP LLC, LOS ANGELES, CA. SN 85-050,406. PUB. 10-26-2010, FILED 5-28-2010.

**BLXSWAP**

THE MARK CONSISTS OF STANDARD CHARACTERS WITHOUT CLAIM TO ANY PARTICULAR FONT, STYLE, SIZE, OR COLOR.

OWNER OF U.S. REG. NOS. 3,443,577 AND 3,521,848. FOR PROVIDING ONLINE NON-DOWNLOADABLE SOFTWARE FOR MONITORING AND REPORTING INFORMATION REGARDING INTEREST RATE DERIVATIVES; PROVIDING ONLINE NON-DOWNLOADABLE SOFTWARE THAT PROVIDES ELECTRONIC ALERTS AND E-MAIL REPORTS REGARDING INFORMATION RELATING TO INTEREST RATE DERIVATIVES (U.S. CLS. 100 AND 101).

FIRST USE 3-30-2010; IN COMMERCE 3-30-2010.

**CLASS 42—(Continued).**

3,942,204. GRUMPYFACE STUDIOS LLC, GILBERT, AZ. SN 85-051,185. PUB. 10-26-2010, FILED 5-31-2010.

**GRUMPYFACE**

THE MARK CONSISTS OF STANDARD CHARACTERS WITHOUT CLAIM TO ANY PARTICULAR FONT, STYLE, SIZE, OR COLOR.

FOR COMPUTER PROGRAMMING AND SOFTWARE DESIGN; SOFTWARE DESIGN AND DEVELOPMENT (U.S. CLS. 100 AND 101).

FIRST USE 11-18-2010; IN COMMERCE 11-18-2010.

---

3,942,214. CYBERMARK INTERNATIONAL, INC., PHOENIX, AZ. SN 85-053,471. PUB. 11-23-2010, FILED 6-3-2010.

**LEAD HOUND**

THE MARK CONSISTS OF STANDARD CHARACTERS WITHOUT CLAIM TO ANY PARTICULAR FONT, STYLE, SIZE, OR COLOR.

NO CLAIM IS MADE TO THE EXCLUSIVE RIGHT TO USE "LEAD", APART FROM THE MARK AS SHOWN.

FOR PROVIDING TEMPORARY USE OF NON-DOWNLOADABLE SOFTWARE FOR USE IN TRACKING, INTEGRATING AND MANAGING SALES CONTACTS AND SALES PROSPECTS (U.S. CLS. 100 AND 101).

FIRST USE 7-1-2010; IN COMMERCE 7-1-2010.

---

3,942,255. ADOBE SYSTEMS INCORPORATED, SAN JOSE, CA. SN 85-065,678. PUB. 10-5-2010, FILED 6-17-2010.

**FLASH**

THE MARK CONSISTS OF STANDARD CHARACTERS WITHOUT CLAIM TO ANY PARTICULAR FONT, STYLE, SIZE, OR COLOR.

**CLASS 42—(Continued).**

OWNER OF U.S. REG. NOS. 2,852,245, 3,473,651, AND OTHERS.

FOR COMPUTER SERVICES, NAMELY, PROVIDING TEMPORARY USE OF ONLINE, NON-DOWNLOADABLE SOFTWARE FOR PRODUCTION, DELIVERY AND PRESENTATION OF RICH WEB APPLICATIONS, AND FOR COLLABORATIVE AUTHORING AND EDITING OF MULTIMEDIA DOCUMENTS; COMPUTER SERVICES, NAMELY, PROVIDING TEMPORARY USE OF ONLINE, NON-DOWNLOADABLE SOFTWARE AND SOFTWARE DEVELOPER TOOLS USED IN CREATING SOCIAL NETWORKING FEATURES FOR RICH INTERNET APPLICATIONS; COMPUTER SERVICES, NAMELY, PROVIDING TEMPORARY USE OF ONLINE, NON-DOWNLOADABLE SOFTWARE AND SOFTWARE DEVELOPER TOOLS USED TO PROMOTE, DISTRIBUTE, INSTALL, TRACK, SHARE, LINK AND INTEGRATE SOFTWARE APPLICATIONS AND ANALYZE THE DISTRIBUTION AND USE OF SOFTWARE APPLICATIONS AND COLLECT DATA REGARDING USER PREFERENCES AND DEMOGRAPHIC AND GEOGRAPHIC INFORMATION REGARDING DOWNLOAD AND INSTALLATION OF SOFTWARE APPLICATIONS ON SOCIAL NETWORKS, SOCIAL NETWORKING PAGES, WEB SITES, COMPUTER NETWORKS, USER DESKTOPS, AND MOBILE AND HAND-HELD DEVICES, AND VIA THE INTERNET, COMPUTER NETWORKS, AND OTHER TELECOMMUNICATIONS NETWORKS, AND TO TRACK REVENUES ASSOCIATED WITH SUCH APPLICATIONS; COMPUTER SERVICES, NAMELY, PROVIDING TEMPORARY USE OF ONLINE, NON-DOWNLOADABLE SOFTWARE AND SOFTWARE DEVELOPER TOOLS USED TO HOST ADVERTISEMENTS, PROMOTE THE GOODS AND SERVICES OF OTHERS, AND TRACK WEB SITE TRAFFIC, E-COMMERCE ACTIVITY, CUSTOMER LOYALTY, AND SALES CONVERSION RATES ON SOCIAL NETWORKS, SOCIAL NETWORKING PAGES, COMPUTER NETWORKS, USER DESKTOPS, AND MOBILE AND HAND-HELD DEVICES, AND VIA THE INTERNET, COMPUTER NETWORKS, AND OTHER TELECOMMUNICATIONS NETWORKS, AND TO TRACK REVENUES ASSOCIATED WITH SUCH HOSTED ADVERTISEMENTS; COMPUTER SERVICES, NAMELY, PROVIDING TEMPORARY USE OF ONLINE, NON-DOWNLOADABLE SOFTWARE AND SOFTWARE DEVELOPER TOOLS USED TO CUSTOMIZE SOFTWARE APPLICATIONS AND USER INTERFACES AND OPTIMIZE WEBSITE NAVIGATION BASED ON COLLECTED DATA, INCLUDING USER IDENTIFYING DEMOGRAPHICS, USER PREFERENCES, AND SOCIAL NETWORKING SITE AND WEB PAGE INSTALLATION LOCATION; COMPUTER SERVICES, NAMELY, PROVIDING TEMPORARY USE OF ONLINE, NON-DOWNLOADABLE SOFTWARE AND SOFTWARE DEVELOPER TOOLS USED TO ADD SOCIAL NETWORKING AND MULTI-USER COLLABORATION CAPABILITIES AND FEATURES TO SOFTWARE APPLICATIONS AND WEB SITES, INCLUDING CHAT WINDOWS, INSTANT MESSAGING, ELECTRONIC MESSAGING, EMAILS, TEXT MESSAGES, ELECTRONIC BULLETIN BOARDS, MULTI-USER WHITEBOARDS, BLOGS, FORUMS, GAMES, MULTI-PLAYER GAMES, STATUS UPDATES, INFORMATIONAL MESSAGES, SCREEN SHARING, AUDIO AND VIDEO SHARING, AND FILE SHARING; COMPUTER SERVICES, NAMELY, PROVIDING TEMPORARY USE OF ONLINE, NON-DOWNLOADABLE SOFTWARE AND SOFTWARE DEVELOPER TOOLS USED TO ALLOW USERS TO COLLABORATE IN REAL-TIME, WITH SHARED ACCESS TO DATA, DOCUMENTS, IMAGES, AUDIO, VIDEO, AND SOFTWARE APPLICATIONS THROUGH A WEB BROWSER; COMPUTER SERVICES, NAMELY, PROVIDING TEMPORARY USE OF ONLINE, NON-DOWNLOADABLE SOFTWARE AND SOFTWARE DEVELOPER TOOLS USED TO ENABLE UPLOADING, POSTING, SHOWING, DISPLAYING, PUBLISHING, DISSEMINATING, CREATING, TAGGING, BLOGGING, SHARING, PLAYING BACK, FACILITATING THE ELECTRONIC TRANSMISSION OF, OR OTHERWISE PROVIDING ELECTRONIC MEDIA, INFORMATION, DATA, DOCUMENTS, VOICE, IMAGES, AUDIO AND VIDEO VIA THE INTERNET, TELECOMMUNICATIONS NETWORKS, AND MOBILE COMMUNICATION DEVICES, AND FOR MONITORING AND TRACKING THE SAME; COMPUTER SERVICES, NAMELY, PROVIDING TEMPORARY USE OF ONLINE, NON-DOWNLOADABLE SOFTWARE AND SOFTWARE DEVELOPER TOOLS USED TO COLLECT, EDIT, ORGANIZE, MOD-

**CLASS 42—(Continued).**

IFY, TRANSMIT, STORE, ARCHIVE AND SHARE DATA AND INFORMATION; COMPUTER SERVICES, NAMELY, PROVIDING TEMPORARY USE OF ONLINE, NON-DOWNLOADABLE WEB CONFERENCING SOFTWARE; COMPUTER SERVICES, NAMELY, PROVIDING TEMPORARY USE OF ONLINE, NON-DOWNLOADABLE SOFTWARE AND SOFTWARE DEVELOPER TOOLS USED TO CREATE, DELIVER, SHARE AND DISCUSS INTERACTIVE PRESENTATIONS AND MULTIMEDIA CONTENT VIA THE INTERNET, COMPUTER NETWORKS, AND OTHER TELECOMMUNICATIONS NETWORKS, AND MOBILE COMMUNICATIONS DEVICES; COMPUTER SERVICES, NAMELY, PROVIDING TEMPORARY USE OF ONLINE, NON-DOWNLOADABLE SOFTWARE AND SOFTWARE DEVELOPER TOOLS USED TO CREATE, DELIVER, SHARE AND DISCUSS INTERACTIVE, MEDIA-RICH EDUCATIONAL CLASSES, SEMINARS, WORKSHOPS AND PROGRAMS VIA THE INTERNET, COMPUTER NETWORKS AND OTHER TELECOMMUNICATIONS NETWORKS, AND MOBILE COMMUNICATIONS DEVICES; COMPUTER SERVICES, NAMELY, PROVIDING TEMPORARY USE OF ONLINE, NON-DOWNLOADABLE COMPUTER SOFTWARE DEVELOPMENT TOOLS; APPLICATION SERVICE PROVIDER (ASP) SERVICES, NAMELY, HOSTING COMPUTER SOFTWARE APPLICATION FOR OTHERS AND FACILITATING THE INTEROPERABILITY OF MULTIPLE SOFTWARE APPLICATIONS; HOSTING OF DIGITAL CONTENT ON COMPUTER NETWORKS (U.S. CLS. 100 AND 101).

FIRST USE 1-11-2009; IN COMMERCE 9-21-2009.

3,942,258. FEEDBREWER INC., BROOMFIELD, CO. SN 85-066,324. PUB. 11-16-2010, FILED 6-18-2010.

# BookBrewer

THE MARK CONSISTS OF STANDARD CHARACTERS WITHOUT CLAIM TO ANY PARTICULAR FONT, STYLE, SIZE, OR COLOR.

FOR PROVIDING A WEB-BASED SERVICE FEATURING TECHNOLOGY THAT ENABLES USERS TO MANAGE THE PRODUCTION AND PUBLICATION OF ELECTRONIC BOOKS (E-BOOKS) AND RELATED DIGITAL CONTENT AND OFFER THEM FOR SALE THROUGH ONLINE BOOKSELLERS (U.S. CLS. 100 AND 101).

FIRST USE 8-1-2010; IN COMMERCE 10-31-2010.

**CLASS 42—(Continued).**

3,942,291. BIZILLA.COM, LLC, MIDLOTHIAN, VA. SN 85-079,189. PUB. 12-7-2010, FILED 7-7-2010.

# BIZILLA

THE MARK CONSISTS OF STANDARD CHARACTERS WITHOUT CLAIM TO ANY PARTICULAR FONT, STYLE, SIZE, OR COLOR.

FOR PROVIDING AN ONLINE NETWORK SERVICE THAT ENABLES USERS TO SHARE BUSINESS DATA AND INFORMATION FOR THE PURPOSE OF FACILITATING BUSINESS ACQUISITION MATCHES (U.S. CLS. 100 AND 101).

FIRST USE 10-1-2010; IN COMMERCE 10-1-2010.

3,942,326. HEALTHFUSION, INC., SOLANA BEACH, CA. SN 85-975,093. PUB. 10-5-2010, FILED 5-12-2010.

# CLAIMS ANGEL

THE MARK CONSISTS OF STANDARD CHARACTERS WITHOUT CLAIM TO ANY PARTICULAR FONT, STYLE, SIZE, OR COLOR.

NO CLAIM IS MADE TO THE EXCLUSIVE RIGHT TO USE "CLAIMS", APART FROM THE MARK AS SHOWN.

FOR PROVIDING TEMPORARY USE OF ONLINE NON DOWNLOADABLE SOFTWARE TO PROVIDE EMAIL ALERTS REGARDING PATIENT ELIGIBILITY FOR MEDICAL BENEFITS AND IN THE COORDINATION OF PATIENT REFERRALS AND BILLING FOR RENDERED SERVICES (U.S. CLS. 100 AND 101).

FIRST USE 5-1-2010; IN COMMERCE 1-19-2011.

**CLASS 43—HOTEL AND RESTAURANT SERVICES**

3,941,019. CREPE360, LLC, ATLANTA, GA. SN 77-098,156. PUB. 11-4-2008, FILED 2-2-2007.



NO CLAIM IS MADE TO THE EXCLUSIVE RIGHT TO USE "CREPE", APART FROM THE MARK AS SHOWN.

**CLASS 43—(Continued).**

THE MARK CONSISTS OF THE WORD "CREPE" AND THE NUMBER "360" WITH EACH NUMBER "3", "6", AND "0" IN A BLACK CIRCLE.

FOR RESTAURANT SERVICES (U.S. CLS. 100 AND 101).

FIRST USE 10-1-2010; IN COMMERCE 10-1-2010.

3,941,149. LATIN INTELLECTUAL PROPERTIES, INC., LOS ANGELES, CA. SN 77-596,178. PUB. 6-2-2009, FILED 10-20-2008.



OWNER OF U.S. REG. NOS. 2,230,802 AND 2,685,071.

THE COLOR(S) ORANGE, BLACK, YELLOW AND BEIGE IS/ARE CLAIMED AS A FEATURE OF THE MARK.

THE MARK CONSISTS OF THE TERMS "THE CONGA ROOM" IN THE COLOR BEIGE IN FRONT OF TWO DRUMS IN THE COLORS ORANGE, BLACK AND YELLOW ON A BEIGE BACKGROUND.

SEC. 2(F) AS TO "THE CONGA ROOM".

FOR RESTAURANT SERVICES; BAR SERVICES; RESTAURANTS FEATURING EAT-IN, TAKE-OUT AND DELIVERY SERVICES; AND SELF-SERVICE RESTAURANTS; CATERING OF FOOD AND DRINKS; FOOD PREPARATION; AND CONTRACT FOOD SERVICES (U.S. CLS. 100 AND 101).

FIRST USE 12-0-2008; IN COMMERCE 12-0-2008.

3,941,200. BUBBA FOODS, LLC, JACKSONVILLE, FL. SN 77-652,095. PUB. 5-5-2009, FILED 1-19-2009.

# BUBBA BURGER GRILL

THE MARK CONSISTS OF STANDARD CHARACTERS WITHOUT CLAIM TO ANY PARTICULAR FONT, STYLE, SIZE, OR COLOR.

OWNER OF U.S. REG. NO. 2,659,731.

NO CLAIM IS MADE TO THE EXCLUSIVE RIGHT TO USE "BURGER GRILL", APART FROM THE MARK AS SHOWN.

FOR RESTAURANT AND BAR SERVICES (U.S. CLS. 100 AND 101).

FIRST USE 1-14-2011; IN COMMERCE 1-14-2011.

**CLASS 43—(Continued).**

3,941,247. BALDWIN-LINDSEY, JANICE, PENSACOLA, FL. AND BALDWIN, HERBERT A., PENSACOLA, FL. AND BALDWIN-TALTON, CAROLYN, PENSACOLA, FL. AND BALDWIN, LUTHER J., PENSACOLA, FL. AND BALDWIN-HARVEY, PATRICIA, PENSACOLA, FL. AND BALDWIN, MARK B., PENSACOLA, FL. AND BALDWIN, STEVE G., PENSACOLA, FL. AND BALDWIN-WILLIAMS, PERRILEE A., PENSACOLA, FL. SN 77-703,159. PUB. 7-28-2009, FILED 3-31-2009.

## MEN AND WOMEN OF THE HOUSE

THE MARK CONSISTS OF STANDARD CHARACTERS WITHOUT CLAIM TO ANY PARTICULAR FONT, STYLE, SIZE, OR COLOR.

FOR BOOKING OF CATERING SERVICES FOR OTHERS; CATERING; CHILD CARE SERVICES; CONSULTING SERVICES IN THE FIELD OF CULINARY ARTS; CONSULTING SERVICES IN THE FIELD OF HOSPITALITY; MAKING HOTEL RESERVATIONS FOR OTHERS; PROVIDING BANQUET AND SOCIAL FUNCTION FACILITIES FOR SPECIAL OCCASIONS; RESTAURANT (U.S. CLS. 100 AND 101).

FIRST USE 4-11-2009; IN COMMERCE 4-11-2009.

3,941,353. FUJIAN VEGSALON CATERING CO., LTD., ZHANGZHOU, FUJIAN, CHINA. SN 77-777,141. PUB. 6-1-2010, FILED 7-8-2009.



YUAN SU DOES NOT IDENTIFY A LIVING INDIVIDUAL.

THE MARK CONSISTS OF TWO CHINESE CHARACTERS AND A DEVICE. THE DEVICE IS A LOTUS AND THE TWO CHINESE CHARACTERS ARE UNDER THE LOTUS.

THE NON-LATIN CHARACTERS IN THE MARK TRANSLITERATE TO YUAN SU AND THIS HAS NO MEANING IN A FOREIGN LANGUAGE.

FOR BAR SERVICES; BOARDING FOR ANIMALS; CAFES; CAFETERIAS; CANTEN SERVICES; CATERING OF FOOD AND DRINKS; HOTEL ACCOMMODATION SERVICES; PROVIDING TEMPORARY ACCOMMODATION; SNACK-BARS; TEA ROOMS; TOURIST HOMES (U.S. CLS. 100 AND 101).

FIRST USE 2-13-2010; IN COMMERCE 2-13-2010.

**CLASS 43—(Continued).**

3,941,384. 940 OCEAN DRIVE LLC, MIAMI BEACH, FL. SN 77-790,198. PUB. 12-22-2009, FILED 7-27-2009.

## BREAKWATER HOTEL

THE MARK CONSISTS OF STANDARD CHARACTERS WITHOUT CLAIM TO ANY PARTICULAR FONT, STYLE, SIZE, OR COLOR.

NO CLAIM IS MADE TO THE EXCLUSIVE RIGHT TO USE "HOTEL", APART FROM THE MARK AS SHOWN.

FOR HOTEL AND RESTAURANT SERVICES (U.S. CLS. 100 AND 101).

FIRST USE 8-18-2010; IN COMMERCE 8-18-2010.

3,941,395. AVENIR LIFESTYLES CORP., SCOTTSDALE, AZ. SN 77-794,898. PUB. 5-18-2010, FILED 7-31-2009.

## arté

THE MARK CONSISTS OF STANDARD CHARACTERS WITHOUT CLAIM TO ANY PARTICULAR FONT, STYLE, SIZE, OR COLOR.

THE ENGLISH TRANSLATION OF "ARTE" IN THE MARK IS "ART".

FOR FOOD PREPARATION SERVICES; RETIREMENT HOMES; RESIDENTIAL HOTELS; PROVIDING ASSISTED LIVING FACILITIES; PROVIDING ASSISTANCE TO SENIOR CITIZENS SEEKING TO DETERMINE ASSISTED LIVING FACILITIES APPROPRIATE FOR THEIR NEEDS (U.S. CLS. 100 AND 101).

FIRST USE 7-0-2009; IN COMMERCE 7-0-2009.

3,941,397. AVENIR LIFESTYLES CORP., SCOTTSDALE, AZ. SN 77-794,906. PUB. 5-18-2010, FILED 7-31-2009.

## RESORT RETIREMENT LIVING

THE MARK CONSISTS OF STANDARD CHARACTERS WITHOUT CLAIM TO ANY PARTICULAR FONT, STYLE, SIZE, OR COLOR.

NO CLAIM IS MADE TO THE EXCLUSIVE RIGHT TO USE "RETIREMENT LIVING", APART FROM THE MARK AS SHOWN.

FOR FOOD PREPARATION SERVICES; RETIREMENT HOMES; RESIDENTIAL HOTELS; PROVIDING ASSISTED LIVING FACILITIES; PROVIDING ASSISTANCE TO SENIOR CITIZENS SEEKING TO DETERMINE ASSISTED LIVING FACILITIES APPROPRIATE FOR THEIR NEEDS (U.S. CLS. 100 AND 101).

FIRST USE 7-0-2009; IN COMMERCE 7-0-2009.

**CLASS 43—(Continued).**

3,941,399. AVENIR LIFESTYLES CORP., SCOTTSDALE, AZ. SN 77-794,911. PUB. 5-18-2010, FILED 7-31-2009.

RETIREMENT THAT LIVES LIKE  
A RESORT

THE MARK CONSISTS OF STANDARD CHARACTERS WITHOUT CLAIM TO ANY PARTICULAR FONT, STYLE, SIZE, OR COLOR.

FOR FOOD PREPARATION SERVICES; RETIREMENT HOMES; RESIDENTIAL HOTELS; PROVIDING ASSISTED LIVING FACILITIES; PROVIDING ASSISTANCE TO SENIOR CITIZENS SEEKING TO DETERMINE ASSISTED LIVING FACILITIES APPROPRIATE FOR THEIR NEEDS (U.S. CLS. 100 AND 101).

FIRST USE 7-0-2009; IN COMMERCE 7-0-2009.

3,941,450. RJ MILANO, NAPERVILLE, IL. SN 77-820,011. PUB. 2-2-2010, FILED 9-3-2009.

Shaky Alibi

THE MARK CONSISTS OF STANDARD CHARACTERS WITHOUT CLAIM TO ANY PARTICULAR FONT, STYLE, SIZE, OR COLOR.

FOR RESTAURANT SERVICES, NAMELY, PROVIDING OF FOOD AND BEVERAGES FOR CONSUMPTION ON AND OFF THE PREMISES (U.S. CLS. 100 AND 101).

FIRST USE 1-15-2010; IN COMMERCE 7-1-2010.

3,941,488. TACOS LA SILLA, L.L.C., MISSION, TX. SN 77-842,663. PUB. 5-11-2010, FILED 10-6-2009.



NO CLAIM IS MADE TO THE EXCLUSIVE RIGHT TO USE "TACOS", APART FROM THE MARK AS SHOWN.

THE MARK CONSISTS OF "TACOS" ABOVE AND TO THE LEFT OF MOUNTAINS HAVING A RADIO TOWER, AND "LA SILLA" BELOW THE MOUNTAINS.

**CLASS 43—(Continued).**

THE ENGLISH TRANSLATION OF "LA SILLA" IN THE MARK IS "THE CHAIR".

FOR BAR AND RESTAURANT SERVICES; CAFE AND RESTAURANT SERVICES; CAFETERIA AND RESTAURANT SERVICES; CARRY-OUT RESTAURANTS; DELICATESSENS; FAST-FOOD RESTAURANTS; RESTAURANT; RESTAURANT AND BAR SERVICES; RESTAURANT SERVICES FEATURING MEXICAN CUISINE; RESTAURANT, BAR AND CATERING SERVICES; SELF-SERVICE RESTAURANTS; TAKE-OUT RESTAURANT SERVICES (U.S. CLS. 100 AND 101).

FIRST USE 2-4-2010; IN COMMERCE 2-4-2010.

3,941,513. BARNESGOULD, SANDY, APPLE VALLEY, CA. AND GOULD, WILLIAM, APPLE VALLEY, CA. AND POLLOCK, ROBERT, APPLE VALLEY, CA. SN 77-856,569. PUB. 6-8-2010, FILED 10-23-2009.

**BOBI'S**



**Bubbles & Tea**

NO CLAIM IS MADE TO THE EXCLUSIVE RIGHT TO USE "BUBBLES & TEA", APART FROM THE MARK AS SHOWN.

THE MARK CONSISTS OF THE STYLIZED TEXT "BOBI'S BUBBLES & TEA" WITH A CUP OF BUBBLE TEA IN THE MIDDLE.

FOR CATERING OF FOOD AND DRINKS (U.S. CLS. 100 AND 101).

FIRST USE 1-28-2010; IN COMMERCE 1-28-2010.

3,941,514. CHECKERS DRIVE-IN RESTAURANTS, INC., TAMPA, FL. SN 77-856,712. PUB. 3-30-2010, FILED 10-24-2009.

FEAST ON

THE MARK CONSISTS OF STANDARD CHARACTERS WITHOUT CLAIM TO ANY PARTICULAR FONT, STYLE, SIZE, OR COLOR.

FOR RESTAURANT SERVICES (U.S. CLS. 100 AND 101).

FIRST USE 11-25-2010; IN COMMERCE 11-25-2010.

**CLASS 43—(Continued).**

3,941,649. CONXIS, INC., SAN DIMAS, CA. SN 77-894,534.  
PUB. 5-11-2010, FILED 12-16-2009.



THE MARK CONSISTS OF THE LETTERS "UFOODZ" WITH THE FIRST "O" APPEARING AS A SOLID FOOD PLATE WITH A SPOON RESTING THEREON, AND THE SECOND "O" APPEARING AS A SOLID FOOD PLATE WITH A FORK RESTING THEREON.

FOR PROVIDING AN ONLINE COMPUTER DATABASE TO CONSUMERS CONCERNING RECIPES, INGREDIENTS AND COOKING INFORMATION; PROVIDING REVIEWS OF RESTAURANTS; SOMMELIER SERVICES, NAMELY, PROVIDING ADVICE ON WINE AND WINE AND FOOD PAIRING (U.S. CLS. 100 AND 101).

FIRST USE 6-15-2010; IN COMMERCE 6-15-2010.

3,941,651. CONXIS, INC., SAN DIMAS, CA. SN 77-894,608.  
PUB. 5-11-2010, FILED 12-16-2009.

**UFOODZ**

THE MARK CONSISTS OF STANDARD CHARACTERS WITHOUT CLAIM TO ANY PARTICULAR FONT, STYLE, SIZE, OR COLOR.

FOR PROVIDING AN ONLINE COMPUTER DATABASE TO CONSUMERS CONCERNING RECIPES, INGREDIENTS AND COOKING INFORMATION; PROVIDING REVIEWS OF RESTAURANTS; SOMMELIER SERVICES, NAMELY, PROVIDING ADVICE ON WINE AND WINE AND FOOD PAIRING (U.S. CLS. 100 AND 101).

FIRST USE 6-15-2010; IN COMMERCE 6-15-2010.

**CLASS 43—(Continued).**

3,941,652. CONXIS, INC., SAN DIMAS, CA. SN 77-894,631.  
PUB. 5-11-2010, FILED 12-16-2009.

**ITS ABOUT TASTE**

THE MARK CONSISTS OF STANDARD CHARACTERS WITHOUT CLAIM TO ANY PARTICULAR FONT, STYLE, SIZE, OR COLOR.

FOR PROVIDING AN ONLINE COMPUTER DATABASE TO CONSUMERS CONCERNING RECIPES, INGREDIENTS AND COOKING INFORMATION; PROVIDING REVIEWS OF RESTAURANTS; SOMMELIER SERVICES, NAMELY, PROVIDING ADVICE ON WINE AND WINE AND FOOD PAIRING (U.S. CLS. 100 AND 101).

FIRST USE 6-15-2010; IN COMMERCE 6-15-2010.

3,941,653. CONXIS, INC., SAN DIMAS, CA. SN 77-894,652.  
PUB. 8-31-2010, FILED 12-16-2009.

**COOKS CRUMBS**

THE MARK CONSISTS OF STANDARD CHARACTERS WITHOUT CLAIM TO ANY PARTICULAR FONT, STYLE, SIZE, OR COLOR.

NO CLAIM IS MADE TO THE EXCLUSIVE RIGHT TO USE "COOKS", APART FROM THE MARK AS SHOWN.

FOR PROVIDING AN ONLINE COMPUTER DATABASE TO CONSUMERS CONCERNING RECIPES, INGREDIENTS AND COOKING INFORMATION; SOMMELIER SERVICES, NAMELY, PROVIDING ADVICE ON WINE AND WINE AND FOOD PAIRING (U.S. CLS. 100 AND 101).

FIRST USE 6-15-2010; IN COMMERCE 6-15-2010.

3,941,741. BENNIGAN'S IP, LLC, DALLAS, TX. SN 77-909,043.  
PUB. 5-25-2010, FILED 1-11-2010.

**BENNIGAN'S AMERICAN FARE,  
IRISH HOSPITALITY**

THE MARK CONSISTS OF STANDARD CHARACTERS WITHOUT CLAIM TO ANY PARTICULAR FONT, STYLE, SIZE, OR COLOR.

OWNER OF U.S. REG. NOS. 1,088,917, 3,427,829, AND OTHERS.

FOR RESTAURANT AND BAR SERVICES (U.S. CLS. 100 AND 101).

FIRST USE 1-31-2010; IN COMMERCE 1-31-2010.

**CLASS 43—(Continued).**

3,941,801. PAR TECHNOLOGY CORPORATION, NEW HARTFORD, NY. SN 77-919,005. PUB. 6-15-2010, FILED 1-25-2010.



OWNER OF U.S. REG. NO. 3,686,108.

NO CLAIM IS MADE TO THE EXCLUSIVE RIGHT TO USE "HOSPITALITY", APART FROM THE MARK AS SHOWN.

THE MARK CONSISTS OF A SERIES OF THREE ROWS OF DOTS OF SLIGHTLY INCREASING DIAMETER AS EACH ROW EXTENDS FROM BOTTOM TOWARDS THE TOP AND THAT IS POSITIONED TO THE LEFT OF THE WORDS BOUNDLESS HOSPITALITY BY PAR AND WITH A PINEAPPLE TOP POSITIONED ADJACENT THE WORD "PAR".

FOR CONSULTING SERVICES IN THE FIELD OF HOSPITALITY (U.S. CLS. 100 AND 101).

FIRST USE 10-0-2010; IN COMMERCE 10-0-2010.

3,941,831. WESTINGHOUSE ELECTRIC COMPANY LLC, CRANBERRY TOWNSHIP, PA. SN 77-922,488. PUB. 8-3-2010, FILED 1-28-2010.



OWNER OF U.S. REG. NO. 3,465,622.

NO CLAIM IS MADE TO THE EXCLUSIVE RIGHT TO USE "NUTRITION", APART FROM THE MARK AS SHOWN.

THE COLOR(S) BLUE, ORANGE AND WHITE IS/ARE CLAIMED AS A FEATURE OF THE MARK.

THE MARK CONSISTS OF AN ORANGE ARC WITH BLUE RAYS EMANATING FROM THE TOP SURFACE THEREOF. THE WORD "NEW" IN BLUE AND THE WORD "START" IN ORANGE ARE LOCATED BENEATH THE ARC. THE WORDS "NUTRITION EXERCISE WELLNESS" IN WHITE ON A BLUE RECTANGULAR BACKGROUND ARE LOCATED BENEATH THE WORDS "NEW" AND "START".

FOR RESTAURANT SERVICES (U.S. CLS. 100 AND 101).

FIRST USE 7-11-2007; IN COMMERCE 7-11-2007.

**CLASS 43—(Continued).**

3,941,967. ZIGGY'S CHEESESTEAKS, SOUTHFIELD, MI. SN 77-958,205. PUB. 11-2-2010, FILED 3-12-2010.



NO CLAIM IS MADE TO THE EXCLUSIVE RIGHT TO USE "CHEESESTEAKS", "BORN IN SOUTH PHILLY" AND THE DESIGN OF THE CHEESESTEAK, APART FROM THE MARK AS SHOWN.

THE MARK CONSISTS OF A ROUND LOGO WITH THE STYLIZED TEXT "ZIGGY'S CHEESESTEAKS BORN IN SOUTH PHILLY" ON THE OUTER RING AND A CHEESESTEAK ON THE INNER RING.

FOR RESTAURANT SERVICES (U.S. CLS. 100 AND 101).

FIRST USE 10-5-2010; IN COMMERCE 10-5-2010.

3,941,971. MARRIOTT INTERNATIONAL, INC., BETHESDA, MD. SN 77-958,784. PUB. 7-20-2010, FILED 3-15-2010.

# CRAZYBOX

THE MARK CONSISTS OF STANDARD CHARACTERS WITHOUT CLAIM TO ANY PARTICULAR FONT, STYLE, SIZE, OR COLOR.

FOR BAR AND RESTAURANT SERVICES; COCKTAIL LOUNGE SERVICES (U.S. CLS. 100 AND 101).

FIRST USE 9-28-2010; IN COMMERCE 9-28-2010.



**CLASS 43—(Continued).**

3,942,000. CARROLL, CRYSTAL, PASCO, WA. SN 77-969,669.  
PUB. 8-17-2010, FILED 3-26-2010.



NO CLAIM IS MADE TO THE EXCLUSIVE RIGHT TO USE "FROZEN YOGURT", APART FROM THE MARK AS SHOWN.

THE COLOR(S) WHITE, PURPLE, GREEN, AND RED IS/ARE CLAIMED AS A FEATURE OF THE MARK.

THE MARK CONSISTS OF A PURPLE AND WHITE SWIRL OF FROZEN YOGURT WITH GREEN DOTS VARYING IN SIZE SPRINKLED AROUND AND ABOVE THE SWIRL IMAGE, THE WORDING "MYFROYO" SUPERIMPOSED OVER THE BOTTOM OF THE SWIRL IN PURPLE AND WHITE COLORS, AND WITH THE WORDING "FROZEN YOGURT" IN RED UNDERNEATH AND OFF CENTER TO THE RIGHT, ALL THE FOREGOING WITH A WHITE BACKGROUND.

FOR FROZEN YOGURT SHOP SERVICES IN THE NATURE OF A RESTAURANT (U.S. CLS. 100 AND 101).  
FIRST USE 5-31-2010; IN COMMERCE 5-31-2010.

3,942,028. AZUR LIMITED, LONDON, UNITED KINGDOM.  
SN 77-981,275. PUB. 8-24-2010, FILED 9-18-2009.

**LA PETITE MAISON**

THE MARK CONSISTS OF STANDARD CHARACTERS WITHOUT CLAIM TO ANY PARTICULAR FONT, STYLE, SIZE, OR COLOR.

THE ENGLISH TRANSLATION OF THE WORD "LA PETITE MAISON" IN THE MARK IS "LITTLE HOUSE".

FOR RESTAURANT, BAR AND COCKTAIL LOUNGE SERVICES (U.S. CLS. 100 AND 101).

FIRST USE 12-8-2010; IN COMMERCE 12-8-2010.

3,942,050. ROTELLI PIZZA & PASTA, INC., BOCA RATON, FL. SN 78-551,857. PUB. 11-14-2006, FILED 1-21-2005.



OWNER OF U.S. REG. NO. 2,871,483.  
THE COLOR(S) RED, WHITE, BLACK AND ORANGE IS/ARE CLAIMED AS A FEATURE OF THE MARK.

**CLASS 43—(Continued).**

THE MARK CONSISTS OF AN ORANGE PIZZA PAN WITH WHITE FLAMES RISING ABOVE IT ALL ON A BLACK SQUARE CARRIER. TO THE RIGHT OF THE DESIGN IS THE WORDING "ROTELLI" IN RED.

FOR RESTAURANT (U.S. CLS. 100 AND 101).  
FIRST USE 1-1-1999; IN COMMERCE 1-1-1999.

3,942,069. CRIMAPI HOTELS S.R.L., BARDOLINO (VERONA), ITALY. SN 78-930,535. PUB. 7-6-2010, FILED 7-17-2006.

**COLOR HOTEL**

THE MARK CONSISTS OF STANDARD CHARACTERS WITHOUT CLAIM TO ANY PARTICULAR FONT, STYLE, SIZE, OR COLOR.

OWNER OF ITALY REG. NO. 991392, DATED 2-1-2006, EXPIRES 1-18-2012.

NO CLAIM IS MADE TO THE EXCLUSIVE RIGHT TO USE "HOTEL", APART FROM THE MARK AS SHOWN.

FOR PROVIDING TEMPORARY TOURIST ACCOMMODATIONS; HOTEL SERVICES; MAKING HOTEL RESERVATIONS FOR OTHERS; TRAVEL AGENCIES SERVICES, NAMELY, MAKING RESERVATIONS AND BOOKING FOR TEMPORARY LODGING SUCH AS BOARDING HOUSES, GUEST HOUSES AND HOTELS; HOTEL SERVICES FOR PREFERRED CUSTOMERS; ALL THE AFORESAID BEING SERVICES RENDERED INSIDE OF HOTELS AND BOARDING HOUSES AND BEING SERVICES ON BEHALF OF THIRD PARTIES (U.S. CLS. 100 AND 101).

FIRST USE 4-9-2003; IN COMMERCE 4-9-2003.

3,942,176. MALAWI'S PIZZA, LLC, PROVO, UT. SN 85-044,868. PUB. 9-21-2010, FILED 5-21-2010.



NO CLAIM IS MADE TO THE EXCLUSIVE RIGHT TO USE "PIZZA", APART FROM THE MARK AS SHOWN.

THE COLOR(S) RED, BLACK, WHITE, ORANGE AND YELLOW IS/ARE CLAIMED AS A FEATURE OF THE MARK.

THE MARK CONSISTS OF THE DESIGN OF THE SILHOUETTES OF AN ADULT ELEPHANT AND BABY

**CLASS 43—(Continued).**

ELEPHANT IN THE COLOR BLACK TO THE RIGHT OF A SILHOUETTE OF A TREE IN THE COLOR BLACK, BEHIND THE SILHOUETTES IS THE DESIGN OF A SETTING SUN HAVING A GRADIENT OF RED, ORANGE AND YELLOW. BELOW THE SILHOUETTES AND SUN DESIGNS IS THE STYLIZED WORDING "MALAWI'S PIZZA" IN THE COLOR BLACK WITH A WHITE INLINE, THE STYLIZED WORDING "PIZZA WITH A PURPOSE" IN THE COLOR BLACK, AND A JAGGED UNDERLINE IN THE COLOR BLACK UNDER THE WORDING.

FOR RESTAURANT SERVICES; RESTAURANT SERVICES THAT DONATE FUNDS FOR MEALS TO THOSE IN NEED (U.S. CLS. 100 AND 101).

FIRST USE 8-31-2010; IN COMMERCE 8-31-2010.

---

3,942,288. CHOICE HOTELS INTERNATIONAL, INC., SILVER SPRING, MD. SN 85-075,722. PUB. 11-30-2010, FILED 7-1-2010.

**DESIGNED TO DREAM**

THE MARK CONSISTS OF STANDARD CHARACTERS WITHOUT CLAIM TO ANY PARTICULAR FONT, STYLE, SIZE, OR COLOR.

FOR HOTEL AND MOTEL SERVICES (U.S. CLS. 100 AND 101).

FIRST USE 12-8-2010; IN COMMERCE 12-8-2010.

---

3,942,302. GRILLED CHEESE TO GO LLC, MILFORD, CT. SN 85-083,016. PUB. 12-14-2010, FILED 7-13-2010.

**CHEESEBOY**

THE MARK CONSISTS OF STANDARD CHARACTERS WITHOUT CLAIM TO ANY PARTICULAR FONT, STYLE, SIZE, OR COLOR.

FOR CARRY-OUT RESTAURANTS; FAST-FOOD RESTAURANTS; RESTAURANT SERVICES; TAKE-OUT RESTAURANT SERVICES (U.S. CLS. 100 AND 101).

FIRST USE 10-24-2010; IN COMMERCE 11-30-2010.

**CLASS 44—MEDICAL, BEAUTY AND AGRICULTURAL SERVICES****CLASS 44—(Continued).**

3,941,146. ON THE GO WELLNESS, HICKMAN, NE. SN 77-591,263. PUB. 10-27-2009, FILED 10-13-2008.

**ON THE GO WELLNESS**

THE MARK CONSISTS OF STANDARD CHARACTERS WITHOUT CLAIM TO ANY PARTICULAR FONT, STYLE, SIZE, OR COLOR.

NO CLAIM IS MADE TO THE EXCLUSIVE RIGHT TO USE "WELLNESS", APART FROM THE MARK AS SHOWN.

FOR CONSULTING SERVICES IN THE FIELD OF MENTAL HEALTH AND WELLNESS; HEALTH CARE SERVICES, NAMELY, WELLNESS PROGRAMS; PROVIDING ASSISTANCE, FITNESS EVALUATION AND CONSULTATION TO INDIVIDUALS TO HELP THEM MAKE HEALTH, WELLNESS AND NUTRITIONAL CHANGES IN THEIR DAILY LIVING TO IMPROVE HEALTH (U.S. CLS. 100 AND 101).

FIRST USE 11-1-2009; IN COMMERCE 11-1-2009.

---

3,941,205. HELLASMED LLC, HOUSTON, TX. SN 77-655,898. PUB. 11-17-2009, FILED 1-24-2009.

**THE POWER TO CONTROL YOUR DIABETES IS IN YOUR HANDS**

THE MARK CONSISTS OF STANDARD CHARACTERS WITHOUT CLAIM TO ANY PARTICULAR FONT, STYLE, SIZE, OR COLOR.

NO CLAIM IS MADE TO THE EXCLUSIVE RIGHT TO USE "YOUR DIABETES", APART FROM THE MARK AS SHOWN.

FOR HEALTH CARE SERVICES, NAMELY, DISEASE MANAGEMENT PROGRAMS (U.S. CLS. 100 AND 101).

FIRST USE 1-1-2011; IN COMMERCE 1-1-2011.

---

3,941,381. EPISENCIAL, LLC, LOS ANGELES, CA. SN 77-788,494. PUB. 6-8-2010, FILED 7-23-2009.

**Green From Day One**

THE MARK CONSISTS OF STANDARD CHARACTERS WITHOUT CLAIM TO ANY PARTICULAR FONT, STYLE, SIZE, OR COLOR.

**CLASS 44—(Continued).**

NO CLAIM IS MADE TO THE EXCLUSIVE RIGHT TO USE "GREEN", APART FROM THE MARK AS SHOWN.

FOR PROVIDING INFORMATION IN THE FIELD OF CHILDREN'S HEALTH AND WELLNESS AND PARENTING CONCERNING THE HEALTH OF CHILDREN TO MAINTAIN A HEALTHY CHILD; CONSULTING SERVICES IN THE FIELD OF CHILDREN'S HEALTH AND WELLNESS AND PARENTING CONCERNING THE HEALTH OF CHILDREN TO MAINTAIN A HEALTHY CHILD; PROVIDING A WEBSITE FEATURING EDUCATIONAL INFORMATION IN THE FIELD OF CHILDREN'S HEALTH AND WELLNESS AND PARENTING CONCERNING THE HEALTH OF CHILDREN TO MAINTAIN A HEALTHY CHILD (U.S. CLS. 100 AND 101).

FIRST USE 9-0-2010; IN COMMERCE 9-0-2010.

---

3,941,396. AVENIR LIFESTYLES CORP., SCOTTSDALE, AZ.  
SN 77-794,905. PUB. 5-18-2010, FILED 7-31-2009.

arté

THE MARK CONSISTS OF STANDARD CHARACTERS WITHOUT CLAIM TO ANY PARTICULAR FONT, STYLE, SIZE, OR COLOR.

THE ENGLISH TRANSLATION OF "ARTE" IN THE MARK IS "ART".

FOR MEDICAL SERVICES, NAMELY, PROVIDING ASSISTED LIVING MEDICAL CARE AND MEDICAL CARE PROGRAMS; NURSING HOMES (U.S. CLS. 100 AND 101).

FIRST USE 7-0-2009; IN COMMERCE 7-0-2009.

---

3,941,398. AVENIR LIFESTYLES CORP., SCOTTSDALE, AZ.  
SN 77-794,908. PUB. 5-18-2010, FILED 7-31-2009.

RESORT RETIREMENT LIVING

THE MARK CONSISTS OF STANDARD CHARACTERS WITHOUT CLAIM TO ANY PARTICULAR FONT, STYLE, SIZE, OR COLOR.

NO CLAIM IS MADE TO THE EXCLUSIVE RIGHT TO USE "RETIREMENT LIVING", APART FROM THE MARK AS SHOWN.

FOR MEDICAL SERVICES, NAMELY, PROVIDING ASSISTED LIVING MEDICAL CARE AND MEDICAL CARE PROGRAMS; NURSING HOMES (U.S. CLS. 100 AND 101).

FIRST USE 7-0-2009; IN COMMERCE 7-0-2009.

**CLASS 44—(Continued).**

3,941,442. DISHMAN, VALLORIE, DBA HOSANNA CREATIONS, INC., TEMPLE HILLS, MD. SN 77-814,172. PUB. 10-12-2010, FILED 8-27-2009.



NO CLAIM IS MADE TO THE EXCLUSIVE RIGHT TO USE "INC." AND "A PET THERAPY MINISTRY", APART FROM THE MARK AS SHOWN.

THE MARK CONSISTS OF A STYLIZED PICTURE OF THE FRONT SIDE OF A DOG. THE DOG IS SITUATED WITHIN AN ARC/HALF CIRCLE. THE ENDS OF THE ARCS ARE POINTED UPWARD. BELOW THE DOG AND ON THE ARC, IT SAYS "A PET THERAPY MINISTRY" IN CURSIVE. ABOVE THE DOG IT SAYS, "HOSANNA CREATIONS, INC.".

FOR STRESS REDUCTION THERAPY FOR HUMAN PATIENTS USING CANINES (U.S. CLS. 100 AND 101).

FIRST USE 7-12-2009; IN COMMERCE 9-29-2009.

---

3,941,507. HEALTHY INTERACTIONS, INC, SYLVANIA, OH. SN 77-853,404. PUB. 4-27-2010, FILED 10-21-2009.

CONVERSATION CLUB

THE MARK CONSISTS OF STANDARD CHARACTERS WITHOUT CLAIM TO ANY PARTICULAR FONT, STYLE, SIZE, OR COLOR.

FOR PROVIDING HEALTH CARE SERVICES AND MEDICAL COUNSELING SERVICES TO PATIENTS AND HEALTHCARE PROFESSIONALS RELATING TO DISEASES AND PRACTICES IN THE HEALTH CARE INDUSTRY (U.S. CLS. 100 AND 101).

FIRST USE 11-23-2009; IN COMMERCE 11-23-2009.

**CLASS 44—(Continued).**

3,941,654. AMIDA CARE INC., NEW YORK, NY. SN 77-894,667. PUB. 5-25-2010, FILED 12-16-2009.

## AMIDA CARE

THE MARK CONSISTS OF STANDARD CHARACTERS WITHOUT CLAIM TO ANY PARTICULAR FONT, STYLE, SIZE, OR COLOR.

NO CLAIM IS MADE TO THE EXCLUSIVE RIGHT TO USE "CARE", APART FROM THE MARK AS SHOWN.

FOR MANAGED HEALTH CARE SERVICES FOR THOSE WITH SPECIAL NEEDS (U.S. CLS. 100 AND 101).  
FIRST USE 4-1-2010; IN COMMERCE 4-1-2010.

---

3,941,699. MEDITOUR EXPO LLC, NEW YORK, NY. SN 77-900,854. PUB. 7-13-2010, FILED 12-24-2009.

## INTERNATIONAL MEDITOUR ZONE

THE MARK CONSISTS OF STANDARD CHARACTERS WITHOUT CLAIM TO ANY PARTICULAR FONT, STYLE, SIZE, OR COLOR.

NO CLAIM IS MADE TO THE EXCLUSIVE RIGHT TO USE "INTERNATIONAL" AND "ZONE", APART FROM THE MARK AS SHOWN.

FOR HEALTHCARE AND MEDICAL TOURISM SERVICES, NAMELY, ESTABLISHING AND MAINTAINING A HEALTHCARE PROVIDER NETWORK IN OTHER COUNTRIES FOR THE PROVISION OF HEALTHCARE SERVICES (U.S. CLS. 100 AND 101).  
FIRST USE 0-0-2006; IN COMMERCE 0-0-2006.

---

3,941,710. UNIVITA HEALTH INC., SCOTTSDALE, AZ. SN 77-903,125. PUB. 5-18-2010, FILED 12-30-2009.

## UNIVITA LIVING

THE MARK CONSISTS OF STANDARD CHARACTERS WITHOUT CLAIM TO ANY PARTICULAR FONT, STYLE, SIZE, OR COLOR.

FOR TELEPHONIC AND WEB SUPPORT PROGRAM TO SUPPORT CONSUMERS IN FINDING AND ACCESSING HOME HEALTH CARE PRODUCTS AND SERVICES; HEALTHCARE SERVICES, NAMELY, INTEGRATED HEALTHCARE SERVICES WITH A NETWORK OF NATIONAL HEALTHCARE PROVIDERS (U.S. CLS. 100 AND 101).  
FIRST USE 3-2-2009; IN COMMERCE 6-15-2009.

**CLASS 44—(Continued).**

3,941,720. LAWN DOCTOR, INC., HOLMDEL, NJ. SN 77-904,621. PUB. 5-18-2010, FILED 1-4-2010.

## YOUR LAWN YOUR CHOICE

THE MARK CONSISTS OF STANDARD CHARACTERS WITHOUT CLAIM TO ANY PARTICULAR FONT, STYLE, SIZE, OR COLOR.

FOR LAWN MAINTENANCE SERVICES (U.S. CLS. 100 AND 101).  
FIRST USE 7-28-2009; IN COMMERCE 7-28-2009.

---

3,941,739. WOUND CARE ASSOCIATES, COVINGTON, LA. SN 77-908,770. PUB. 6-1-2010, FILED 1-11-2010.

## TeleWound

THE MARK CONSISTS OF STANDARD CHARACTERS WITHOUT CLAIM TO ANY PARTICULAR FONT, STYLE, SIZE, OR COLOR.

FOR TELEMEDICINE SERVICES (U.S. CLS. 100 AND 101).  
FIRST USE 2-1-2010; IN COMMERCE 2-1-2010.

---

3,941,864. U.S. DEPARTMENT OF HEALTH AND HUMAN SERVICES, BETHESDA, MD. SN 77-928,323. PUB. 6-15-2010, FILED 2-4-2010.

## QuitBoost

THE MARK CONSISTS OF STANDARD CHARACTERS WITHOUT CLAIM TO ANY PARTICULAR FONT, STYLE, SIZE, OR COLOR.

FOR PROVIDING SMOKING CESSATION TREATMENT SERVICES VIA A SOCIAL NETWORKING WEB SITE THAT FEATURES INFORMATION FOR WOMEN ABOUT SMOKING CESSATION (U.S. CLS. 100 AND 101).  
FIRST USE 2-12-2010; IN COMMERCE 2-12-2010.

**CLASS 44—(Continued).**

3,941,961. WEIGHT WATCHERS INTERNATIONAL, INC., NEW YORK, NY. SN 77-956,761. PUB. 7-27-2010, FILED 3-11-2010.



The logo for PointsPlus consists of the word "PointsPlus" in a bold, sans-serif font. The "Plus" is in a smaller font size than "Points". A registered trademark symbol (®) is located to the upper right of the "s" in "Plus".

OWNER OF U.S. REG. NOS. 2,139,767, 3,346,918, AND OTHERS.

THE MARK CONSISTS OF THE WORDING "POINTS-PLUS" AND A DESIGN OF A PLUS SIGN WITHIN A CIRCULAR BORDER DEPICTED IN SUPERSCRIP TO THE RIGHT OF THE WORDING.

FOR PROVIDING SERVICES FOR WEIGHT REDUCTION PLANNING, TREATMENT AND SUPERVISION; CONSULTATION SERVICES IN THE FIELDS OF WEIGHT REDUCTION, WEIGHT CONTROL, NUTRITION AND FITNESS; PROVISION OF INFORMATION IN THE FIELDS OF WEIGHT REDUCTION, WEIGHT CONTROL, NUTRITION AND FITNESS; PROVIDING A WEBSITE AND ONLINE DATABASE FEATURING INFORMATION CONCERNING WEIGHT REDUCTION, WEIGHT CONTROL, NUTRITION AND FITNESS (U.S. CLS. 100 AND 101).

FIRST USE 11-28-2010; IN COMMERCE 11-28-2010.

3,941,984. SOLTA MEDICAL, INC., HAYWARD, CA. SN 77-963,488. PUB. 8-10-2010, FILED 3-19-2010.



The logo for THERMAFRAX consists of the word "THERMAFRAX" in a bold, serif font.

THE MARK CONSISTS OF STANDARD CHARACTERS WITHOUT CLAIM TO ANY PARTICULAR FONT, STYLE, SIZE, OR COLOR.

OWNER OF U.S. REG. NOS. 2,534,746, 3,259,488, AND OTHERS.

FOR COSMETIC AND PLASTIC SURGERY AND DERMATOLOGICAL TREATMENT OF THE SKIN (U.S. CLS. 100 AND 101).

FIRST USE 6-2-2009; IN COMMERCE 6-2-2009.

**CLASS 44—(Continued).**

3,942,012. SIERRA HEALTHSTYLES LLC, TUCSON, AZ. SN 77-981,122. PUB. 3-4-2008, FILED 5-15-2007.



OWNER OF U.S. REG. NOS. 2,195,695 AND 3,300,221.

THE MARK CONSISTS OF THE LETTER "I" IN STYLIZED FORM.

FOR HEALTH, BEAUTY AND SPA SERVICES AND TREATMENTS, NAMELY, MASSAGES, BODY WRAPS, FACIALS, EXFOLIATION TREATMENTS, HAIR REMOVAL TREATMENTS, BODY AND FACE WAXING TREATMENTS, SAUNA AND HYDROTHERAPY TREATMENTS, HEAT TREATMENTS, AROMATHERAPY TREATMENTS, MANICURES, PEDICURES, AND SCALP TREATMENTS; HEALTH SPA SERVICES FOR HEALTH AND WELLNESS OF THE BODY, MIND AND SPIRIT OFFERED AT A HEALTH RESORT; HEALTHCARE SERVICES IN THE FIELD OF WELLNESS PROGRAMS; COUNSELING IN THE FIELD OF STRESS MANAGEMENT; STRESS REDUCTION THERAPY (U.S. CLS. 100 AND 101).

FIRST USE 3-31-2004; IN COMMERCE 3-31-2004.

3,942,021. BEHINDTHECHAIR.COM, LLC, ROSELLE, IL. SN 77-981,235. PUB. 4-29-2008, FILED 6-18-2007.



The logo for who does your hair.com consists of the text "who does your hair.com" in a lowercase, sans-serif font. The word "who" is in a smaller font size than "does your hair". The ".com" is in a smaller font size than "hair".

THE MARK CONSISTS OF THE NAME "WHODOES-YOURHAIR.COM" IN A STYLIZED FONT.

FOR PROVIDING INFORMATION ABOUT BEAUTY, NAMELY, AN ONLINE DATABASE IN THE FIELDS OF BEAUTY AND HAIR CARE (U.S. CLS. 100 AND 101).

FIRST USE 7-14-2007; IN COMMERCE 7-14-2007.

**CLASS 44—(Continued).**

3,942,083. TYRONE INJURY & WELLNESS CENTER, LLC., ST. PETERSBURG, FL. SN 85-003,338. PUB. 10-19-2010, FILED 3-31-2010.

# DR FIRST

THE MARK CONSISTS OF STANDARD CHARACTERS WITHOUT CLAIM TO ANY PARTICULAR FONT, STYLE, SIZE, OR COLOR.

THE NAME IN THE MARK DOES NOT IDENTIFY A PARTICULAR LIVING INDIVIDUAL.

FOR CHIROPRACTIC SERVICES (U.S. CLS. 100 AND 101).

FIRST USE 1-5-2011; IN COMMERCE 1-5-2011.

3,942,128. VASCULAR VIEW LLC, SALT LAKE CITY, UT. SN 85-024,195. PUB. 10-12-2010, FILED 4-27-2010.



NO CLAIM IS MADE TO THE EXCLUSIVE RIGHT TO USE "VASCULAR", APART FROM THE MARK AS SHOWN. THE COLOR(S) ORANGE, YELLOW, RED, AND BLACK IS/ARE CLAIMED AS A FEATURE OF THE MARK.

THE MARK CONSISTS OF A STYLIZED CIRCLE THAT IS RED, ORANGE AND YELLOW; TO THE RIGHT IN BLACK STYLIZED LETTERS IS "VASCULAR VIEW" WITH BLACK LINES ABOVE AND BENEATH THE WORDING.

FOR MEDICAL IMAGING SERVICES, NAMELY, CONSULTING SERVICES IN THE FIELD OF USING AND OPERATING MEDICAL IMAGING APPARATUS INCLUDING X-RAY, COMPUTED TOMOGRAPHY, MAGNETIC RESONANCE IMAGING, ULTRASOUND, AND POSITRON EMISSION TOMOGRAPHY APPARATUS (U.S. CLS. 100 AND 101).

FIRST USE 4-5-2010; IN COMMERCE 4-19-2010.

3,942,146. CANCEROPINIONS.COM, LLC, OMAHA, NE. SN 85-031,646. PUB. 11-2-2010, FILED 5-6-2010.

NO CLAIM IS MADE TO THE EXCLUSIVE RIGHT TO USE "CANCER OPINIONS.COM", APART FROM THE MARK AS SHOWN.

**CLASS 44—(Continued).**

THE MARK CONSISTS OF THE WORDS "CANCER" AND "OPINIONS" AS ONE WORD FOLLOWED BY ".COM". THERE IS A THIN ARCH ABOVE THE LETTERS "I" AND "N" OF THE WORD "OPINIONS" AND A LARGER ARCH ABOVE THE RIGHT END OF THE THIN ARCH AND OVER THE LETTERS "N" AND THE SECOND "I" OF THE WORD "OPINIONS".

FOR MEDICAL CONSULTATION SERVICES FOR SECOND OPINIONS (U.S. CLS. 100 AND 101).

FIRST USE 6-20-2010; IN COMMERCE 6-20-2010.

3,942,160. BLUE HERON NURSERIES, LLC., WINTER GARDEN, FL. SN 85-039,934. PUB. 11-2-2010, FILED 5-17-2010.



OWNER OF U.S. REG. NO. 3,777,952.

NO CLAIM IS MADE TO THE EXCLUSIVE RIGHT TO USE "NURSERIES", APART FROM THE MARK AS SHOWN.

THE MARK CONSISTS OF A HERON FLYING ACROSS A GROVE OF ORANGE TREES. THE WORDING "BLUE HERON NURSERIES" APPEARS AT THE BOTTOM OF THE MARK. A STYLIZED DESIGN OF FOUR ORANGES APPEARS ABOVE THE WORD "HERON".

FOR TREE NURSERIES; PLANT NURSERIES (U.S. CLS. 100 AND 101).

FIRST USE 8-1-2009; IN COMMERCE 8-1-2009.

**CLASS 45—PERSONAL AND LEGAL SERVICES**

3,941,346. ILL DIALECT, INC., ARDMORE, PA. SN 77-775,232. PUB. 5-25-2010, FILED 7-7-2009.

# ILL DIALECT

THE MARK CONSISTS OF STANDARD CHARACTERS WITHOUT CLAIM TO ANY PARTICULAR FONT, STYLE, SIZE, OR COLOR.

FOR PROVIDING A SOCIAL NETWORKING WEBSITE FOR ENTERTAINMENT PURPOSES; ONLINE SOCIAL NETWORKING SERVICES (U.S. CLS. 100 AND 101).

FIRST USE 12-1-2010; IN COMMERCE 12-1-2010.

**CLASS 45—(Continued).**

3,941,366. ACTIVE SINGLES, LLC, DBA ELITE MATCHMAKING, BEVERLY HILLS, CA. SN 77-783,103. PUB. 6-22-2010, FILED 7-16-2009.

ELITE MATCHMAKING

THE MARK CONSISTS OF STANDARD CHARACTERS WITHOUT CLAIM TO ANY PARTICULAR FONT, STYLE, SIZE, OR COLOR.

NO CLAIM IS MADE TO THE EXCLUSIVE RIGHT TO USE "MATCHMAKING", APART FROM THE MARK AS SHOWN.

FOR DATING SERVICES; MARRIAGE PARTNER INTRODUCTION OR DATING SERVICES; SOCIAL INTRODUCTION AGENCIES (U.S. CLS. 100 AND 101).  
FIRST USE 1-15-2011; IN COMMERCE 1-15-2011.



3,941,373. NEPTUNE MANAGEMENT CORP., PLANTATION, NY. SN 77-784,963. PUB. 6-15-2010, FILED 7-20-2009.

**CLASS 45—(Continued).**

3,941,374. NEPTUNE MANAGEMENT CORP., PLANTATION, FL. SN 77-784,969. PUB. 6-15-2010, FILED 7-20-2009.



MEMORIALIZED  
CREMATION

NO CLAIM IS MADE TO THE EXCLUSIVE RIGHT TO USE "MEMORIALIZED CREMATION", APART FROM THE MARK AS SHOWN.

THE MARK CONSISTS OF A GLOBE DESIGN ENCLOSED TOWERS, WITH A HUMAN AND A DOLPHIN SWIMMING.

FOR FUNERAL, BURIAL AND CREMATION SERVICES (U.S. CLS. 100 AND 101).  
FIRST USE 1-0-2010; IN COMMERCE 1-0-2010.



3,941,408. INTERNATIONAL PREMATURE OVARIAN FAILURE ASSOCIATION, INC, ALEXANDRIA, VA. SN 77-799,478. PUB. 7-13-2010, FILED 8-7-2009.



NO CLAIM IS MADE TO THE EXCLUSIVE RIGHT TO USE "INTERNATIONAL PREMATURE OVARIAN FAILURE ASSOCIATION", APART FROM THE MARK AS SHOWN.

THE MARK CONSISTS OF THE STYLIZED LETTERS AND WORDS "IPOFA INTERNATIONAL PREMATURE OVARIAN FAILURE ASSOCIATION". THE LETTER "I" IS IN THE FORM OF A STYLIZED WOMAN.

FOR ORGANIZING AND CONDUCTING SUPPORT GROUPS IN THE FIELD OF WOMEN WITH PREMATURE OVARIAN FAILURE (U.S. CLS. 100 AND 101).  
FIRST USE 10-25-2010; IN COMMERCE 10-25-2010.

THE MARK CONSISTS OF A GLOBE DESIGN ENCLOSED TOWERS, WITH A HUMAN AND A DOLPHIN SWIMMING.

FOR FUNERAL, BURIAL AND CREMATION SERVICES (U.S. CLS. 100 AND 101).  
FIRST USE 7-20-2009; IN COMMERCE 7-20-2009.

**CLASS 45—(Continued).**

3,941,490. JENKINS, MARK E., DBA MARRIAGE 911, ALISO VIEJO, CA. SN 77-843,536. PUB. 3-9-2010, FILED 10-7-2009.

# Marriage 911

THE MARK CONSISTS OF STANDARD CHARACTERS WITHOUT CLAIM TO ANY PARTICULAR FONT, STYLE, SIZE, OR COLOR.

NO CLAIM IS MADE TO THE EXCLUSIVE RIGHT TO USE "MARRIAGE", APART FROM THE MARK AS SHOWN. FOR MARRIAGE COUNSELING (U.S. CLS. 100 AND 101).

FIRST USE 8-1-2009; IN COMMERCE 8-1-2009.

3,941,571. DRIVECAM, INC., SAN DIEGO, CA. SN 77-876,512. PUB. 5-18-2010, FILED 11-19-2009.

# DRIVECAM ONLINE

THE MARK CONSISTS OF STANDARD CHARACTERS WITHOUT CLAIM TO ANY PARTICULAR FONT, STYLE, SIZE, OR COLOR.

OWNER OF U.S. REG. NOS. 3,279,966, 3,376,103, AND OTHERS.

NO CLAIM IS MADE TO THE EXCLUSIVE RIGHT TO USE "ONLINE", APART FROM THE MARK AS SHOWN.

FOR PROVIDING A WEBSITE FEATURING INFORMATION IN THE FIELD OF ACCIDENT INVESTIGATIONS, NAMELY, ACCIDENT RECONSTRUCTION ANALYSIS AND REPORTS; PROVIDING AN ON-LINE COMPUTER DATABASE IN THE FIELD OF ACCIDENT INVESTIGATIONS FEATURING ACCIDENT RECONSTRUCTION ANALYSIS AND REPORTS; PROVIDING A WEBSITE FEATURING INFORMATION RELATING TO ACCIDENT INVESTIGATIONS FOR IDENTIFICATION OF RISKY DRIVING BEHAVIOR (U.S. CLS. 100 AND 101).

FIRST USE 7-25-2008; IN COMMERCE 7-25-2008.

**CLASS 45—(Continued).**

3,941,622. HILARY LIDESTRI, PLANO, TX. SN 77-888,807. PUB. 5-25-2010, FILED 12-8-2009.

# so very clever

THE MARK CONSISTS OF STANDARD CHARACTERS WITHOUT CLAIM TO ANY PARTICULAR FONT, STYLE, SIZE, OR COLOR.

FOR PROVIDING A WEB SITE FEATURING INFORMATION FOR THE GENERAL PUBLIC IN THE FIELD OF PERSONAL RELATIONSHIPS (U.S. CLS. 100 AND 101).

FIRST USE 10-9-2009; IN COMMERCE 10-9-2009.

3,941,828. WAGGONER, WYNDI, OKLAHOMA CITY, OK. SN 77-921,292. PUB. 6-15-2010, FILED 1-27-2010.

# DINING SIMPLE

THE MARK CONSISTS OF STANDARD CHARACTERS WITHOUT CLAIM TO ANY PARTICULAR FONT, STYLE, SIZE, OR COLOR.

NO CLAIM IS MADE TO THE EXCLUSIVE RIGHT TO USE "DINING", APART FROM THE MARK AS SHOWN.

FOR PERSONAL CHEF SERVICES (U.S. CLS. 100 AND 101).

FIRST USE 8-20-2010; IN COMMERCE 8-20-2010.

3,941,832. SHAFFER, W. BENJAMIN, GALENA, OH. SN 77-922,490. PUB. 6-15-2010, FILED 1-28-2010.

# Vade Retro Satana

THE MARK CONSISTS OF STANDARD CHARACTERS WITHOUT CLAIM TO ANY PARTICULAR FONT, STYLE, SIZE, OR COLOR.

THE ENGLISH TRANSLATION OF "VADE RETRO SATANA" IN THE MARK IS "BE GONE, SATAN" OR "GO BACK, SATAN".

FOR CHRISTIAN MINISTRY SERVICES (U.S. CLS. 100 AND 101).

FIRST USE 1-28-2010; IN COMMERCE 7-1-2010.



**CLASS 45—(Continued).**

3,941,955. ELK & ELK CO., LTD., MAYFIELD, OH. SN 77-952,127. PUB. 8-3-2010, FILED 3-5-2010.

**DON'T RIDE WITHOUT US**

THE MARK CONSISTS OF STANDARD CHARACTERS WITHOUT CLAIM TO ANY PARTICULAR FONT, STYLE, SIZE, OR COLOR.  
FOR LEGAL SERVICES (U.S. CLS. 100 AND 101).  
FIRST USE 10-18-2010; IN COMMERCE 10-18-2010.

3,941,979. MY STYLE FILES, CHARLOTTE, NC. SN 77-961,060. PUB. 8-10-2010, FILED 3-17-2010.

**Real style for real women.**

THE MARK CONSISTS OF STANDARD CHARACTERS WITHOUT CLAIM TO ANY PARTICULAR FONT, STYLE, SIZE, OR COLOR.  
FOR FASHION CONSULTING SERVICES (U.S. CLS. 100 AND 101).  
FIRST USE 2-1-2010; IN COMMERCE 6-15-2010.

3,942,193. LBB ENTERPRISES, LLC, DBA IDIGYA, HENDERSON, NV. SN 85-049,224. PUB. 11-2-2010, FILED 5-27-2010.



THE COLOR(S) GOLD, YELLOW, AND GRAY-VIOLET IS/ARE CLAIMED AS A FEATURE OF THE MARK.

THE MARK CONSISTS OF A FIVE PETAL PARTIAL FLOWER AND DETACHED SIXTH PETAL WITH GOLD CENTER FADING TO YELLOW AT THE END OF THE PETALS. ALL PETALS ARE TRIMMED IN YELLOW, AND THE CENTER OF THE FLOWER HAS A GOLD BUD CENTER THAT IS TRIMMED IN A GRAY-VIOLET COLOR. THE GRAY-VIOLET STEM OF THE FLOWER FORMS A CURVED UNDERLINE OF THE STYLIZED GRAY-VIOLET PHRASE "I DIG YA" WHICH APPEARS TO THE LEFT OF THE PETALS.

FOR INTERNET BASED SOCIAL NETWORKING, INTRODUCTION, AND DATING SERVICES (U.S. CLS. 100 AND 101).

FIRST USE 5-26-2010; IN COMMERCE 6-1-2010.

**CLASS 45—(Continued).**

3,942,202. INN, MELINDA, SAN FRANCISCO, CA. SN 85-050,779. PUB. 11-2-2010, FILED 5-28-2010.

**THE INN METHOD**

THE MARK CONSISTS OF STANDARD CHARACTERS WITHOUT CLAIM TO ANY PARTICULAR FONT, STYLE, SIZE, OR COLOR.

NO CLAIM IS MADE TO THE EXCLUSIVE RIGHT TO USE "METHOD", APART FROM THE MARK AS SHOWN.  
FOR PERSONAL LIFESTYLE CONSULTING SERVICES; PROVIDING BOTH IN-PERSON AND ON-LINE HOLISTIC SPIRITUAL COUNSELING SERVICES; PROVIDING SPIRITUAL REHABILITATION SERVICES; SPIRITUAL COUNSELING (U.S. CLS. 100 AND 101).

FIRST USE 8-26-2010; IN COMMERCE 8-26-2010.

3,942,300. PALM, SHERRIE, DBA ASSOCIATION FOR PELVIC ORGAN PROLAPSE SUPPORT, INC., MUKWONAGO, WI. SN 85-082,255. PUB. 12-7-2010, FILED 7-12-2010.

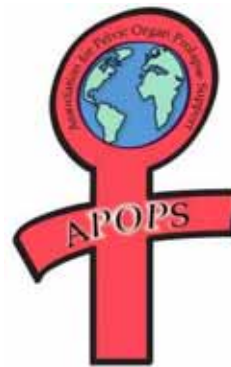

NO CLAIM IS MADE TO THE EXCLUSIVE RIGHT TO USE "ASSOCIATION FOR PELVIC ORGAN PROLAPSE SUPPORT", APART FROM THE MARK AS SHOWN.

THE COLOR(S) RED, GREEN, WHITE, BLUE, AND BLACK IS/ARE CLAIMED AS A FEATURE OF THE MARK.

**CLASS 45—(Continued).**

THE MARK CONSISTS OF THE INSIGNIA FOR WOMEN IN RED AND OUTLINED IN BLACK, A GLOBE OUTLINED IN BLACK WITH BLUE WATER AND GREEN CONTINENTS ALSO OUTLINED IN BLACK IN THE CENTER, THE STYLIZED WORDS "ASSOCIATION FOR PELVIC ORGAN PROLAPSE SUPPORT" IN THE TOP PART OF THE INSIGNIA IN BLACK AND THE STYLIZED WORDS "APOPS" IN THE BODY OF THE INSIGNIA IN BLACK, WHEREAS THE "POP" IN "APOPS" IS HIGHLIGHTED IN WHITE.

FOR ORGANIZING AND CONDUCTING SUPPORT GROUPS IN THE FIELD OF THE WOMEN'S HEALTH CONDITION PELVIC ORGAN PROLAPSE (U.S. CLS. 100 AND 101).

FIRST USE 6-13-2010; IN COMMERCE 9-1-2010.

\* \* \* \* \*

PRIOR UNITED STATES CLASSIFICATION

APPLICATION IN ONE CLASS

COLLECTIVE MEMBERSHIP MARKS

3,941,101. STEPHEN DEANE CROOK, MINNEAPOLIS, MN.  
SN 77-512,349. PUB. 5-25-2010, FILED 7-1-2008.

CLASS 200—COLLECTIVE MEMBERSHIP

3,941,303. AMERICAN FREESTYLE MOTOCROSS ASSOCIA-  
TION, IRVINE, CA. SN 77-759,455. PUB. 11-3-2009, FILED 6-  
15-2009.

AFMXA



THE MARK CONSISTS OF STANDARD CHARACTERS  
WITHOUT CLAIM TO ANY PARTICULAR FONT, STYLE,  
SIZE, OR COLOR.

FOR INDICATING MEMBERSHIP IN AN ASSOCIA-  
TION OF FREESTYLE MOTOCROSS RIDERS (U.S. CL.  
200).

FIRST USE 9-17-2009; IN COMMERCE 9-17-2009.

THE MARK CONSISTS OF THE LETTER "W" ABOVE  
AND TO THE LEFT OF THE LETTER "S", SURROUNDED  
BY A CIRCLE.

THE CERTIFICATION MARK, AS USED OR INTENDED  
TO BE USED BY PERSONS AUTHORIZED BY THE  
CERTIFIER, CERTIFIES THAT THE SERVICES PROVIDED  
HAVE BEEN RENDERED BY QUALIFIED INDIVIDUALS  
WITH TRAINING, PROCEDURES AND EXPERTISE IN  
PROPER WATER HANDLING, DISTRIBUTION TECHNI-  
QUES, AND QUALITY CONTROLS TO ENSURE WATER IS  
SAFE FOR DRINKING AND FREE OF HARMFUL IMPU-  
RITIES.

FOR TESTING, ANALYZING AND CERTIFYING  
WATER QUALITY (U.S. CL. B).

FIRST USE 3-16-2007; IN COMMERCE 1-22-2008.

3,941,931. AMERICAN INSTITUTE OF CERTIFIED PUBLIC  
ACCOUNTANTS, NEW YORK, NY. SN 77-944,833. PUB. 7-  
27-2010, FILED 2-25-2010.

American Institute of CPAs

THE MARK CONSISTS OF STANDARD CHARACTERS  
WITHOUT CLAIM TO ANY PARTICULAR FONT, STYLE,  
SIZE, OR COLOR.

OWNER OF U.S. REG. NOS. 726,823, 728,667, AND  
1,683,413.

SEC. 2(F).  
FOR INDICATING MEMBERSHIP IN AN ASSOCIA-  
TION OF ACCOUNTANTS (U.S. CL. 200).

FIRST USE 5-10-2010; IN COMMERCE 5-10-2010.

3,941,301. NATIONAL ASSOCIATION OF BOARDS OF  
PHARMACY, MOUNT PROSPECT, IL. SN 77-758,677.  
PUB. 7-6-2010, FILED 6-12-2009.

VET-VIPPS

CERTIFICATION MARKS

CLASS B—SERVICES

THE MARK CONSISTS OF STANDARD CHARACTERS  
WITHOUT CLAIM TO ANY PARTICULAR FONT, STYLE,  
SIZE, OR COLOR.

THE CERTIFICATION MARK, AS USED BY AUTHOR-

IZED PERSONS, CERTIFIES THAT THE USERS' WEB SITES THAT DISPENSE DRUGS FOR VETERINARY PURPOSES ADHERE TO CERTAIN MINIMUM STANDARDS AND QUALITY ASSURANCE PROCEDURES, NAMELY, MAINTAINING A STANDARD OF PROFESSIONAL CONDUCT, MAINTAINING APPROPRIATE FEDERAL AND STATE LICENSING, MONITORING POSTED INFORMATION, ALLOWING INSPECTIONS OF THE WEB SITES AND ADHERING TO SPECIFIC REQUIREMENTS FOR THE PROTECTION OF THE HEALTH OF ANIMALS.

FOR ONLINE RETAIL PHARMACY SERVICES (U.S. CL. B).  
FIRST USE 1-12-2011; IN COMMERCE 1-12-2011.

\* \* \* \* \*

# SUPPLEMENTAL REGISTER

These registrations are not subject to opposition.

## SECTION 1.— INTERNATIONAL CLASSIFICATION

The short titles associated below with the international class numbers are terms designed merely for quick identification and are not an official part of the international classification. The full names of international classes are given in section 6.1 of the trademark rules of practice.

The designation "U.S. Cl." appearing in this section refers to the U.S. class in effect prior to Sep. 1, 1973 rather than the international class which applies to applications filed on or after that date. For adoption of international classification see notice in the OFFICIAL GAZETTE of Jun. 26, 1973 (911 O.G. TM 210).

### Application in more than one class

3,942,329. BIRDQUEST, L.L.C., HOUSTON, TX. SN 76-704,568.  
FILED P.R. 9-21-2010; AM. S.R. 2-22-2011.

NO CLAIM IS MADE TO THE EXCLUSIVE RIGHT TO USE "EDUCATION CENTER" AS TO CLASS 41, APART FROM THE MARK AS SHOWN.

## WILD IMAGES

THE MARK CONSISTS OF STANDARD CHARACTERS WITHOUT CLAIM TO ANY PARTICULAR FONT, STYLE, SIZE, OR COLOR.

### CLASS 39—TRANSPORTATION AND STORAGE

FOR ORGANIZING, ARRANGING AND CONDUCTING EDUCATIONAL TOURS FOR THE PURPOSE OF PHOTOGRAPHING ANIMALS, PLANTS OR SCENERY (U.S. CLS. 100 AND 105).

FIRST USE 5-1-2009; IN COMMERCE 5-1-2009.

### CLASS 41—EDUCATION AND ENTERTAINMENT

FOR ORGANIZING, ARRANGING AND CONDUCTING EDUCATIONAL WORKSHOPS FOR THE PURPOSE OF PHOTOGRAPHING ANIMALS, PLANTS OR SCENERY (U.S. CLS. 100, 101 AND 107).

FIRST USE 5-1-2009; IN COMMERCE 5-1-2009.

---

3,942,336. VIETNAM VETERANS MEMORIAL FUND, WASHINGTON, DC. SN 77-685,682. FILED P.R. 3-6-2009; AM. S.R. 1-14-2011.

## THE EDUCATION CENTER AT THE WALL

THE MARK CONSISTS OF STANDARD CHARACTERS WITHOUT CLAIM TO ANY PARTICULAR FONT, STYLE, SIZE, OR COLOR.

### CLASS 16—PAPER GOODS AND PRINTED MATTER

FOR PRINTED MATERIALS AND PUBLICATIONS, NAMELY, BROCHURES, BOOKLETS, AND HANDOUTS ABOUT VIETNAM, THE VIETNAM WAR, THE VIETNAM VETERANS MEMORIAL, OTHER WARS AND MILITARY ENGAGEMENTS, MILITARY SERVICE, AND ISSUES THAT IMPACT VETERANS (U.S. CLS. 2, 5, 22, 23, 29, 37, 38 AND 50).

FIRST USE 9-8-2008; IN COMMERCE 9-8-2008.

### CLASS 35—ADVERTISING AND BUSINESS

FOR PROMOTING PUBLIC AWARENESS OF VIETNAM, THE VIETNAM WAR, THE VIETNAM VETERANS MEMORIAL, OTHER WARS AND MILITARY ENGAGEMENTS, MILITARY SERVICE, AND ISSUES THAT IMPACT VETERANS (U.S. CLS. 100, 101 AND 102).

FIRST USE 4-27-2009; IN COMMERCE 4-27-2009.

### CLASS 41—EDUCATION AND ENTERTAINMENT

FOR MUSEUM AND MUSEUM SERVICES; PREPARING, ORGANIZING, AND DISPLAYING EXHIBITIONS ON VIETNAM, THE VIETNAM WAR, OTHER WARS AND MILITARY ENGAGEMENTS, MILITARY SERVICE, AND ISSUES THAT IMPACT VETERANS FOR EDUCATIONAL AND ENTERTAINMENT PURPOSES; EDUCATIONAL SERVICES, NAMELY, CONDUCTING CLASSES, SEMINARS, EXHIBITIONS, PRESENTATIONS AND SEMINARS RELATED TO VIETNAM, THE VIETNAM WAR, OTHER WARS AND MILITARY ENGAGEMENTS, MILITARY SERVICE, AND ISSUES THAT IMPACT VETERANS; DEVELOPMENT AND DISSEMINATION OF EDUCATIONAL MATERIALS FOR OTHERS ABOUT VIETNAM, THE VIETNAM WAR, THE VIETNAM VETERANS MEMORIAL, OTHER WARS AND MILITARY ENGAGEMENTS, MILITARY SERVICE, AND ISSUES THAT IMPACT VETERANS; PROVIDING AN ONLINE WEBSITE CONTAINING HISTORICAL AND CULTURAL INFORMATION ABOUT VIETNAM, THE VIETNAM WAR, THE VIETNAM VETERANS MEMORIAL, OTHER WARS AND MILITARY ENGAGEMENTS, MILITARY SERVICE, AND THE HISTORY OF MILITARY SERVICE (U.S. CLS. 100, 101 AND 107).

FIRST USE 3-26-2009; IN COMMERCE 3-26-2009.

**CLASS 45—PERSONAL AND LEGAL SERVICES**

FOR PROVIDING AN ONLINE WEBSITE CONTAINING INFORMATION ABOUT THE PERSONAL AND FAMILY LIFESTYLE ISSUES THAT IMPACT VETERANS (U.S. CLS. 100 AND 101).

FIRST USE 9-8-2008; IN COMMERCE 9-8-2008.

---

3,942,341. HARRIS, AL, SALAMANCA, NY. SN 77-822,833. FILED P.R. 9-9-2009; AM. S.R. 2-2-2011.

**SMOKER'S BEST**

THE MARK CONSISTS OF STANDARD CHARACTERS WITHOUT CLAIM TO ANY PARTICULAR FONT, STYLE, SIZE, OR COLOR.

OWNER OF U.S. REG. NO. 3,036,954.

**CLASS 3—COSMETICS AND CLEANING PREPARATIONS**

FOR INCENSE (U.S. CLS. 1, 4, 6, 50, 51 AND 52).  
FIRST USE 12-31-2009; IN COMMERCE 12-31-2009.

**CLASS 4—LUBRICANTS AND FUELS**

FOR CANDLES (U.S. CLS. 1, 6 AND 15).  
FIRST USE 12-31-2009; IN COMMERCE 12-31-2009.

**CLASS 34—SMOKERS' ARTICLES**

FOR CIGARETTE TUBES (U.S. CLS. 2, 8, 9 AND 17).  
FIRST USE 12-31-2009; IN COMMERCE 12-31-2010.

---

3,942,343. NATIONAL PUBLISHING AND TECHNOLOGY, INC., BONITA SPRINGS, FL. SN 77-831,795. FILED P.R. 9-22-2009; AM. S.R. 2-10-2011.

**STRATEGIC INTEGRATED  
COMPUTER MANAGEMENT SYSTEM**

THE MARK CONSISTS OF STANDARD CHARACTERS WITHOUT CLAIM TO ANY PARTICULAR FONT, STYLE, SIZE, OR COLOR.

NO CLAIM IS MADE TO THE EXCLUSIVE RIGHT TO USE "MANAGEMENT SYSTEM", APART FROM THE MARK AS SHOWN.

**CLASS 9—ELECTRICAL AND SCIENTIFIC APPARATUS**

FOR COMPUTER SOFTWARE FOR COMPILING CUSTOMIZED BUSINESS OPERATING POLICIES AND PROCEDURES FROM A PROPRIETARY DATA BASE; DOWNLOADABLE ELECTRONIC PUBLICATIONS IN THE NATURE OF BOOKS, MANUALS, HANDBOOKS, CHECKSHEETS AND TESTS REGARDING BUSINESS OPERATING POLICIES AND PROCEDURES COMPILED FROM A PROPRIETARY DATA BASE; ELECTRONIC PUBLICATIONS IN THE NATURE OF BOOKS, MANUALS, HANDBOOKS, CHECKSHEETS AND TESTS REGARDING BUSINESS OPERATING POLICIES AND PROCEDURES COMPILED FROM A PROPRIETARY DATA BASE (U.S. CLS. 21, 23, 26, 36 AND 38).

FIRST USE 1-12-2011; IN COMMERCE 1-12-2011.

**CLASS 41—EDUCATION AND ENTERTAINMENT**

FOR PROVIDING ON-LINE NON-DOWNLOADABLE PUBLICATIONS IN THE NATURE OF BOOKS, MANUALS, HANDBOOKS, CHECKSHEETS AND TESTS REGARDING BUSINESS OPERATING POLICIES AND PROCEDURES COMPILED FROM A PROPRIETARY DATA BASE (U.S. CLS. 100, 101 AND 107).

FIRST USE 1-12-2011; IN COMMERCE 1-12-2011.

---

3,942,348. AMERITOX LTD, MIDLAND, TX. SN 77-853,008. FILED P.R. 10-20-2009; AM. S.R. 1-20-2011.

**PAIN MEDICATION MONITORING  
SOLUTIONS**

THE MARK CONSISTS OF STANDARD CHARACTERS WITHOUT CLAIM TO ANY PARTICULAR FONT, STYLE, SIZE, OR COLOR.

NO CLAIM IS MADE TO THE EXCLUSIVE RIGHT TO USE "PAIN MEDICATION MONITORING", APART FROM THE MARK AS SHOWN.

**CLASS 42—SCIENTIFIC AND COMPUTER SERVICES**

FOR MEDICAL LABORATORY SERVICES (U.S. CLS. 100 AND 101).

FIRST USE 9-15-2009; IN COMMERCE 9-15-2009.

**CLASS 44—MEDICAL, BEAUTY AND AGRICULTURAL SERVICES**

FOR HEALTH CARE SERVICES, NAMELY, PROVIDING A DATABASE IN THE FIELD OF PATIENT MEDICATION COMPLIANCE INFORMATION AND FEATURING INPUTTING AND COLLECTION OF DATA AND INFORMATION, ALL FOR TREATMENT AND DIAGNOSTIC PURPOSES (U.S. CLS. 100 AND 101).

FIRST USE 9-15-2009; IN COMMERCE 9-15-2009.

3,942,349. TOPANGA TECHNOLOGIES, INC., CANOGA, CA.  
SN 77-854,907. FILED P.R. 10-22-2009; AM. S.R. 2-4-2011.

3,942,356. SAVING AMERICA'S FOUNDATION, RANCHO  
SANTE FE, CA. SN 77-886,933. FILED P.R. 12-4-2009; AM.  
S.R. 2-24-2011.

# TOPANGA

THE MARK CONSISTS OF STANDARD CHARACTERS WITHOUT CLAIM TO ANY PARTICULAR FONT, STYLE, SIZE, OR COLOR.

## CLASS 9—ELECTRICAL AND SCIENTIFIC APPARATUS

FOR HID LIGHT DISPLAYS; HID LIGHT CONTROLS AND POWER SUPPLIES; HEAT SINKS FOR USE WITH ELECTRICAL COMPONENTS (U.S. CLS. 21, 23, 26, 36 AND 38).

FIRST USE 8-5-2010; IN COMMERCE 8-5-2010.

## CLASS 11—ENVIRONMENTAL CONTROL APPARATUS

FOR ELECTRIC LAMPS AND LIGHTING FIXTURES; ELECTRIC LUMINAIRES; ELECTRIC LIGHTING FIXTURES; DECORATIVE LIGHTING FIXTURES (U.S. CLS. 13, 21, 23, 31 AND 34).

FIRST USE 8-5-2010; IN COMMERCE 8-5-2010.

---

3,942,355. ESPADRILLES BANYOLES, S.L., BANYOLES, GIRONA, SPAIN. SN 77-878,448. FILED P.R. 11-23-2009; AM. S.R. 2-24-2011.



OWNER OF U.S. REG. NO. 2,828,277.  
THE COLOR(S) ORANGE IS/ARE CLAIMED AS A FEATURE OF THE MARK.  
THE MARK CONSISTS OF "CASTAÑER" IN ORANGE STYLIZED LETTERS.

## CLASS 18—LEATHER GOODS

FOR BAGS, NAMELY, HANDBAGS, TRAVELLING BAGS, VALISES AND PURSES (U.S. CLS. 1, 2, 3, 22 AND 41).

FIRST USE 6-3-2009; IN COMMERCE 6-3-2009.

## CLASS 25—CLOTHING

FOR FOOTWEAR (U.S. CLS. 22 AND 39).  
FIRST USE 6-3-2009; IN COMMERCE 6-3-2009.

## SAVING AMERICA'S MUSTANGS

THE MARK CONSISTS OF STANDARD CHARACTERS WITHOUT CLAIM TO ANY PARTICULAR FONT, STYLE, SIZE, OR COLOR.

## CLASS 35—ADVERTISING AND BUSINESS

FOR LOBBYING SERVICES, NAMELY, PROMOTING THE INTERESTS OF THE PUBLIC IN THE FIELDS OF POLITICS, LEGISLATION AND REGULATION REGARDING PRESERVATION OF AMERICAN WILD HORSES AND TO CREATE A PUBLIC SPACE FOR LONG TERM CARE, PROTECTION AND PRESERVATION OF AMERICAN WILD HORSES; PROMOTING PUBLIC AWARENESS OF AND INTEREST IN CREATING AN AMERICAN WILD HORSE SANCTUARY; PROMOTING THE PUBLIC AWARENESS OF THE NEED FOR AMERICAN WILD HORSE PRESERVATION, NAMELY, THE PROTECTION OF WILD HORSES AND BURROS THAT HAVE BEEN REMOVED FROM FEDERAL RANGE LANDS; ASSOCIATION SERVICES, NAMELY, PROMOTING INTEREST AND PUBLIC AWARENESS IN THE CREATION, USE AND CONSERVATION OF A DESIGNATED PUBLIC LAND SANCTUARY FOR THE LONG TERM CARE AND PROTECTION OF NON-ADOPTED WILD HORSES AND BURROS THAT HAVE BEEN REMOVED FROM FEDERAL RANGELANDS (U.S. CLS. 100, 101 AND 102).

FIRST USE 1-24-2010; IN COMMERCE 2-23-2011.

## CLASS 36—INSURANCE AND FINANCIAL

FOR CHARITABLE FUND-RAISING SERVICES DESIGNED TO CREATE A SANCTUARY FOR WILD AMERICAN HORSES AND BURROS WILDLIFE MANAGEMENT, HISTORIC PRESERVATION, VISITOR SERVICES AND EDUCATION, AND SCIENTIFIC RESEARCH (U.S. CLS. 100, 101 AND 102).

FIRST USE 1-24-2010; IN COMMERCE 2-23-2011.

## CLASS 41—EDUCATION AND ENTERTAINMENT

FOR PROVIDING INFORMATION RELATING TO AMERICAN WILD HORSES AND BURROS, NAMELY, CONDUCTING INFORMAL PROGRAMS IN THE FIELDS OF CONSERVATION, PRESERVATION AND HISTORY, USING ON-LINE ACTIVITIES AND INTERACTIVE EXHIBITS, AND PRINTABLE MATERIALS DISTRIBUTED THEREWITH (U.S. CLS. 100, 101 AND 107).

FIRST USE 1-24-2010; IN COMMERCE 2-23-2011.

3,942,358. HUMMERT INTERNATIONAL, EARTH CITY, MO. SN 77-895,020. FILED P.R. 12-16-2009; AM. S.R. 2-9-2011.

## Springfield Seed & Supply

THE MARK CONSISTS OF STANDARD CHARACTERS WITHOUT CLAIM TO ANY PARTICULAR FONT, STYLE, SIZE, OR COLOR.

NO CLAIM IS MADE TO THE EXCLUSIVE RIGHT TO USE "SEED AND SUPPLY", APART FROM THE MARK AS SHOWN.

### CLASS 31—NATURAL AGRICULTURAL PRODUCTS

FOR SEEDS FOR HORTICULTURAL PURPOSES (U.S. CLS. 1 AND 46).  
FIRST USE 2-1-2000; IN COMMERCE 2-1-2000.

### CLASS 35—ADVERTISING AND BUSINESS

FOR WHOLESALE DISTRIBUTORSHIPS FEATURING HORTICULTURAL, LAWN, GARDEN, HOUSEHOLD AND AGRICULTURAL PRODUCTS; RETAIL AND ON-LINE STORE SERVICES FEATURING HORTICULTURAL, LAWN, GARDEN, AGRICULTURAL AND HOUSEHOLD PRODUCTS (U.S. CLS. 100, 101 AND 102).  
FIRST USE 2-1-2000; IN COMMERCE 2-1-2000.

3,942,359. SENIOR STAR MANAGEMENT COMPANY, TULSA, OK. SN 77-904,198. FILED P.R. 1-4-2010; AM. S.R. 2-8-2011.

## DESTINATION PROGRAMMING

THE MARK CONSISTS OF STANDARD CHARACTERS WITHOUT CLAIM TO ANY PARTICULAR FONT, STYLE, SIZE, OR COLOR.

NO CLAIM IS MADE TO THE EXCLUSIVE RIGHT TO USE "PROGRAMMING", APART FROM THE MARK AS SHOWN.

### CLASS 35—ADVERTISING AND BUSINESS

FOR PROVIDING NON-MEDICAL SERVICES DESIGNED TO PROMOTE OVERALL WELLBEING FOR ALZHEIMER'S AND DEMENTIA RESIDENTS IN ASSISTED LIVING FACILITIES, MEMORY CARE FACILITIES, SKILLED NURSING FACILITIES AND CONTINUOUS CARE RETIREMENT FACILITIES, NAMELY, PROVISION OF RETAIL STORES FEATURING GENERAL CONSUMER MERCHANDISE IN THEMED DESIGNATION ROOMS AS DESTINATIONS FOR GENERAL STORE AND SUNDRIES ACTIVITIES (U.S. CLS. 100, 101 AND 102).  
FIRST USE 12-13-2009; IN COMMERCE 12-13-2009.

### CLASS 44—MEDICAL, BEAUTY AND AGRICULTURAL SERVICES

FOR PROVIDING NON-MEDICAL SERVICES DESIGNED TO PROMOTE OVERALL WELLBEING FOR ALZHEIMER'S AND DEMENTIA RESIDENTS IN ASSISTED LIVING FACILITIES, MEMORY CARE FACILITIES, SKILLED NURSING FACILITIES AND CONTINUOUS CARE RETIREMENT FACILITIES, NAMELY, PROVISION OF BARBER SHOP AND BEAUTY SALON SERVICES IN THEMED DESIGNATION ROOMS (U.S. CLS. 100 AND 101).  
FIRST USE 12-13-2009; IN COMMERCE 12-13-2009.

### CLASS 45—PERSONAL AND LEGAL SERVICES

FOR PROVIDING NON-MEDICAL SERVICES DESIGNED TO PROMOTE OVERALL WELLBEING FOR ALZHEIMER'S AND DEMENTIA RESIDENTS IN ASSISTED LIVING FACILITIES, MEMORY CARE FACILITIES, SKILLED NURSING FACILITIES AND CONTINUOUS CARE RETIREMENT FACILITIES, NAMELY, PROVISION OF RELIGIOUS PRAYER CHAPEL SERVICES IN THEMED DESIGNATION ROOMS (U.S. CLS. 100 AND 101).  
FIRST USE 12-13-2009; IN COMMERCE 12-13-2009.

3,942,363. JANINE WARNER, LOS ANGELES, CA. SN 77-933,037. FILED P.R. 2-10-2010; AM. S.R. 9-29-2010.

## DIGITAL FAMILY

THE MARK CONSISTS OF STANDARD CHARACTERS WITHOUT CLAIM TO ANY PARTICULAR FONT, STYLE, SIZE, OR COLOR.



**CLASS 35—ADVERTISING AND BUSINESS**

FOR ASSOCIATION SERVICES FOR OTHERS, NAMELY, PROMOTING THE INTERESTS OF BUSINESSES INVOLVED IN WEB DESIGN, WEB DEVELOPMENT, WEB TRAINING, MOBILE WEB DESIGN, WEB DESIGN BUSINESS, ONLINE BUSINESS, SMALL BUSINESS WEB SITES, ECOMMERCE; BUSINESS MONITORING AND CONSULTING SERVICES, NAMELY, TRACKING WEB SITES AND APPLICATIONS OF OTHERS TO PROVIDE STRATEGY, INSIGHT, MARKETING, SALES, OPERATION, PRODUCT DESIGN, PARTICULARLY SPECIALIZING IN THE USE OF ANALYTIC AND STATISTIC MODELS FOR THE UNDERSTANDING AND PREDICTING OF CONSUMERS, BUSINESSES, AND MARKET TRENDS AND ACTIONS; CLUB SERVICES FOR OTHERS, NAMELY, PROMOTING THE INTERESTS OF BUSINESSES INVOLVED IN WEB DESIGN, WEB DEVELOPMENT, WEB TRAINING, MOBILE WEB DESIGN, WEB DESIGN BUSINESS, ONLINE BUSINESS, SMALL BUSINESS WEB SITES, ECOMMERCE; CONSULTING SERVICES IN THE FIELD OF MARKETING OF EDUCATIONAL TRAINING; DISSEMINATION OF ADVERTISING, SCHEDULING AND MANAGING OF TRAINING COURSES AND PROGRAMS FOR OTHERS VIA A GLOBAL COMPUTER NETWORK; PROVIDING ADVERTISING, MARKETING AND PROMOTIONAL SERVICES FOR OTHERS, NAMELY, DEVELOPMENT OF ADVERTISING CAMPAIGNS FOR BUSINESSES INVOLVED IN WEB DESIGN, WEB DEVELOPMENT, WEB TRAINING, MOBILE WEB DESIGN, WEB DESIGN BUSINESSES, ONLINE BUSINESSES, SMALL BUSINESS WEB SITES, ECOMMERCE; PROVIDING MARKETING AND PROMOTION OF SPECIAL EVENTS (U.S. CLS. 100, 101 AND 102).  
FIRST USE 2-28-2006; IN COMMERCE 2-28-2006.

**CLASS 41—EDUCATION AND ENTERTAINMENT**

FOR ARRANGEMENT OF TRAINING COURSES IN TEACHING INSTITUTES; ARRANGING AND CONDUCTING SPECIAL EVENTS; ARRANGING FOR TICKET RESERVATIONS FOR SHOWS AND OTHER ENTERTAINMENT EVENTS; ARRANGING PROFESSIONAL WORKSHOP AND TRAINING COURSES; BUSINESS EDUCATION AND TRAINING SERVICES, NAMELY, DEVELOPING, AND FACILITATING CUSTOMIZED IN-COMPANY LEADERSHIP AND EXECUTIVE DEVELOPMENT PROGRAMS, PROVIDING EXECUTIVE COACHING SERVICES, AND PROVIDING PUBLIC AND IN-COMPANY KEYNOTE PRESENTATIONS TO BUSINESS LEADERS; BUSINESS TRAINING; BUSINESS TRAINING CONSULTANCY SERVICES; CHARITABLE SERVICES FOR OTHERS, NAMELY, PROVIDING TRAINING IN THE FIELDS OF WEB DESIGN, WEB DEVELOPMENT, WEB TRAINING, MOBILE WEB DESIGN, WEB DESIGN BUSINESS, ONLINE BUSINESS, SMALL BUSINESS WEB SITES, ECOMMERCE; COMPUTER EDUCATION TRAINING; COMPUTER EDUCATION TRAINING SERVICES; DEVELOPING TRAINING SYSTEMS AND LEARNING METHODOLOGIES FOR OTHERS; EDUCATION SERVICES, NAMELY, TRAINING EDUCATORS TO TEACH THROUGH SERVICE LEARNING AND CIVIC ENGAGEMENT AND PROVIDING CURRICULA IN CONNECTION THEREWITH; EDUCATIONAL SERVICES FOR OTHERS, NAMELY, CONDUCTING LIVE AND ONLINE TRAINING PROGRAMS IN THE FIELDS OF WEB DESIGN, WEB DEVELOPMENT, WEB TRAINING, MOBILE WEB DESIGN, WEB DESIGN BUSINESSES, ONLINE BUSINESSES, SMALL BUSINESS WEB SITES, ECOMMERCE AND DISTRIBUTION OF TRAINING MATERIAL IN CONNECTION THEREWITH; EDUCATIONAL SERVICES, NAMELY, DEVELOPING AND CONDUCTING TRAINING COURSES AND DISTRIBUTION OF TRAINING MATERIALS IN CONNECTION THEREWITH FOR SUBJECT MATTERS AS REQUESTED BY CUSTOMERS; INTERACTIVE ON-LINE TRAINING SERVICES FOR OTHERS IN THE FIELDS OF WEB DESIGN, WEB DEVELOPMENT, WEB TRAINING, MOBILE WEB DESIGN, WEB DESIGN BUSINESSES, ONLINE BUSINESSES, SMALL BUSINESS WEB SITES, ECOMMERCE; IT TRAINING SERVICES; PROVIDING A WEB SITE WHERE USERS CAN POST RATINGS, REVIEWS AND

RECOMMENDATIONS ON EVENTS AND ACTIVITIES IN THE FIELD OF ENTERTAINMENT AND EDUCATION; PROVIDING ADVICE AND INFORMATION IN THE FIELD OF EDUCATIONAL AND ENTERTAINMENT ACTIVITIES AND EVENTS FOR CHILDREN; PROVIDING CURRENT EVENT NEWS AND INFORMATION VIA A GLOBAL COMPUTER NETWORK; PROVIDING FACILITIES FOR MOVIES, SHOWS, PLAYS, MUSIC OR EDUCATIONAL TRAINING; PROVIDING ON-LINE TRAINING COURSES FOR OTHERS IN THE FIELDS OF WEB DESIGN, WEB DEVELOPMENT, WEB TRAINING, MOBILE WEB DESIGN, WEB DESIGN BUSINESSES, ONLINE BUSINESSES, SMALL BUSINESS WEB SITES, ECOMMERCE; PUBLIC SECTOR BUSINESS TRAINING; TEACHING AND TRAINING IN BUSINESS, INDUSTRY AND INFORMATION TECHNOLOGY; TRAINING SERVICES FOR OTHERS IN THE FIELD OF WEB DESIGN, WEB DEVELOPMENT, WEB TRAINING, MOBILE WEB DESIGN, WEB DESIGN BUSINESSES, ONLINE BUSINESSES, SMALL BUSINESS WEB SITES, ECOMMERCE (U.S. CLS. 100, 101 AND 107).  
FIRST USE 12-31-2005; IN COMMERCE 12-31-2005.

**CLASS 42—SCIENTIFIC AND COMPUTER SERVICES**

FOR CHARITABLE SERVICES, NAMELY, PROVIDING WEB SITE DESIGN FOR OTHERS; CREATION, DESIGN, DEVELOPMENT AND MAINTENANCE OF WEB SITES FOR THIRD PARTIES; DESIGN AND CREATING WEB SITES FOR OTHERS; DESIGN AND MAINTENANCE OF WEB SITES FOR OTHERS; DESIGN OF HOME PAGES AND WEB SITES; DESIGN OF HOME PAGES, COMPUTER SOFTWARE AND WEB SITES; HOSTING AN ONLINE COMMUNITY WEBSITE FEATURING SHARED COMMUNICATIONS BETWEEN COMMUNITY MEMBERS INTERESTED IN PERSONAL AND SMALL BUSINESS COMPUTER INFORMATION SECURITY; PROVIDING A WEBSITE THAT ENABLES USERS TO SUBSCRIBE TO COACHING, MENTORING, AND/OR EDUCATIONAL SERVICES AND TO ENABLE USERS TO AUTHOR AND PUBLISH INSTRUCTIONAL CONTENT FOR OTHERS; WEB SITE DESIGN (U.S. CLS. 100 AND 101).  
FIRST USE 2-28-2005; IN COMMERCE 2-28-2005.

3,942,364. HOUSE FOODS CORPORATION, OSAKA, JAPAN.  
SN 77-933,989. FILED P.R. 2-11-2010; AM. S.R. 1-6-2011.

**UKON ENERGY**

THE MARK CONSISTS OF STANDARD CHARACTERS WITHOUT CLAIM TO ANY PARTICULAR FONT, STYLE, SIZE, OR COLOR.

OWNER OF U.S. REG. NOS. 3,828,755 AND 3,832,181.  
NO CLAIM IS MADE TO THE EXCLUSIVE RIGHT TO USE "UKON", APART FROM THE MARK AS SHOWN.  
THE ENGLISH TRANSLATION OF "UKON" IN THE MARK IS "TURMERIC".

**CLASS 5—PHARMACEUTICALS**

FOR DIETARY SUPPLEMENTAL DRINKS; NUTRITIONAL SUPPLEMENTS (U.S. CLS. 6, 18, 44, 46, 51 AND 52).

FIRST USE 3-15-2010; IN COMMERCE 3-15-2010.

**CLASS 32—LIGHT BEVERAGES**

FOR SOFT DRINKS (U.S. CLS. 45, 46 AND 48).  
FIRST USE 3-15-2010; IN COMMERCE 3-15-2010.

3,942,371. JAMES C. HOWARD, FORT LAUDERDALE, FL. SN 77-955,053. FILED P.R. 3-10-2010; AM. S.R. 2-3-2011.

## COMMODITIES ONLINE

THE MARK CONSISTS OF STANDARD CHARACTERS WITHOUT CLAIM TO ANY PARTICULAR FONT, STYLE, SIZE, OR COLOR.

NO CLAIM IS MADE TO THE EXCLUSIVE RIGHT TO USE "ONLINE", APART FROM THE MARK AS SHOWN.

### CLASS 9—ELECTRICAL AND SCIENTIFIC APPARATUS

FOR DIGITAL MATERIALS, NAMELY, CDS AND DVDS FEATURING INFORMATION ON PHYSICAL COMMODITIES INVESTMENT STRATEGIES TARGETED TOWARDS INDIVIDUAL ACCREDITED INVESTORS (U.S. CLS. 21, 23, 26, 36 AND 38).

FIRST USE 1-29-2010; IN COMMERCE 1-29-2010.

### CLASS 35—ADVERTISING AND BUSINESS

FOR ON-LINE RETAIL STORE SERVICES FEATURING CDS AND DVDS THAT CONTAIN INFORMATION ON PHYSICAL COMMODITIES INVESTMENT STRATEGIES TARGETED TOWARDS INDIVIDUAL ACCREDITED INVESTORS; INFORMATION ON PHYSICAL COMMODITIES; SUBSCRIPTION TO AN ONLINE COMPUTER SERVICES FEATURING INFORMATION ON PHYSICAL COMMODITIES INVESTMENTS TARGETED TOWARDS INDIVIDUAL ACCREDITED INVESTORS (U.S. CLS. 100, 101 AND 102).

FIRST USE 1-29-2010; IN COMMERCE 1-29-2010.

### CLASS 36—INSURANCE AND FINANCIAL

FOR PROVIDING A WEBSITE FEATURING INFORMATION ON PHYSICAL COMMODITIES INVESTMENT STRATEGIES TARGETED TOWARDS INDIVIDUAL ACCREDITED INVESTORS (U.S. CLS. 100, 101 AND 102).

FIRST USE 1-29-2010; IN COMMERCE 1-29-2010.

3,942,388. JOURNAL SENTINEL INC., MILWAUKEE, WI. SN 85-016,810. FILED 4-19-2010.

## MILWAUKEEMOMS.COM

THE MARK CONSISTS OF STANDARD CHARACTERS WITHOUT CLAIM TO ANY PARTICULAR FONT, STYLE, SIZE, OR COLOR.

### CLASS 35—ADVERTISING AND BUSINESS

FOR PROVIDING AN ON-LINE SEARCHABLE DATABASE FEATURING CLASSIFIED AD LISTINGS AND EMPLOYMENT OPPORTUNITIES (U.S. CLS. 100, 101 AND 102).

FIRST USE 0-0-2001; IN COMMERCE 0-0-2001.

### CLASS 38—COMMUNICATION

FOR PROVIDING ON-LINE FORUMS FOR TRANSMISSION OF MESSAGES AMONG COMPUTER USERS CONCERNING PARENTING, CHILDREN AND FAMILIES, PARENTING TIPS AND ADVISE, MOTHERHOOD, CHILDCARE, HEALTH, DIET, EXERCISE, AND NUTRITION; PROVIDING ON-LINE CHAT ROOMS FOR SOCIAL NETWORKING (U.S. CLS. 100, 101 AND 104).

FIRST USE 0-0-2001; IN COMMERCE 0-0-2001.

### CLASS 41—EDUCATION AND ENTERTAINMENT

FOR PROVIDING INFORMATION IN THE FIELDS OF ENTERTAINMENT, RECREATION AND EDUCATION PERTAINING TO LOCAL EVENTS, VENDORS, SERVICES AND RESOURCES FOR PARENTS, CHILDREN, FAMILIES; PROVIDING A WEBSITE FEATURING ON-LINE ARTICLES IN THE FIELDS OF ENTERTAINMENT, RECREATION AND EDUCATION ON TOPICS PERTINENT TO PARENTS, CHILDREN AND FAMILIES; ON-LINE JOURNALS, NAMELY, BLOGS FEATURING STORIES OF MOTHERS, CHILDREN AND THEIR FAMILIES (U.S. CLS. 100, 101 AND 107).

FIRST USE 0-0-2001; IN COMMERCE 0-0-2001.

3,942,394. GENESEE VALLEY MOTORS, INC., AVON, NY. SN 85-018,444. FILED P.R. 4-20-2010; AM. S.R. 1-31-2011.

## "The car dealership for grown-ups!"

THE MARK CONSISTS OF STANDARD CHARACTERS WITHOUT CLAIM TO ANY PARTICULAR FONT, STYLE, SIZE, OR COLOR.

### CLASS 35—ADVERTISING AND BUSINESS

FOR AUTOMOBILE DEALERSHIPS (U.S. CLS. 100, 101 AND 102).

FIRST USE 3-30-2010; IN COMMERCE 3-30-2010.

### CLASS 37—CONSTRUCTION AND REPAIR

FOR VEHICLE REPAIR AND MAINTENANCE (U.S. CLS. 100, 103 AND 106).

FIRST USE 3-30-2010; IN COMMERCE 3-30-2010.

3,942,397. THOMAS A. BRADY SPORTS MEDICINE CENTER, P.C., INDIANAPOLIS, IN. SN 85-019,025. FILED P.R. 4-21-2010; AM. S.R. 1-31-2011.

## INDIANA SPORTS CONCUSSION NETWORK

THE MARK CONSISTS OF STANDARD CHARACTERS WITHOUT CLAIM TO ANY PARTICULAR FONT, STYLE, SIZE, OR COLOR.

NO CLAIM IS MADE TO THE EXCLUSIVE RIGHT TO USE "SPORTS CONCUSSION", APART FROM THE MARK AS SHOWN.

**CLASS 35—ADVERTISING AND BUSINESS**

FOR PROMOTING PUBLIC AWARENESS OF THE RISKS OF SPORTS RELATED CONCUSSIONS AND THE IMPORTANCE OF PROPER MANAGEMENT OF SPORTS RELATED CONCUSSIONS (U.S. CLS. 100, 101 AND 102).

FIRST USE 5-31-2008; IN COMMERCE 5-31-2008.

**CLASS 41—EDUCATION AND ENTERTAINMENT**

FOR EDUCATION SERVICES, NAMELY, PROVIDING CLASSES, SEMINARS AND WORKSHOPS IN THE FIELD OF MEDICAL CARE OF SPORTS RELATED HEAD INJURIES (U.S. CLS. 100, 101 AND 107).

FIRST USE 4-21-2009; IN COMMERCE 4-21-2009.

**CLASS 44—MEDICAL, BEAUTY AND AGRICULTURAL SERVICES**

FOR MEDICAL SERVICES, NAMELY, TREATMENT CARE OF PATIENTS WHO HAVE SUFFERED FROM SPORTS RELATED HEAD INJURIES, AND PRE-INJURY BASELINE TESTING FOR PARTICIPANTS IN SPORTING ACTIVITIES (U.S. CLS. 100 AND 101).

FIRST USE 5-31-2008; IN COMMERCE 5-31-2008.

**CLASS 36—INSURANCE AND FINANCIAL**

FOR FINANCIAL SERVICES, NAMELY, DEBT RESOLUTION SERVICES IN THE NATURE OF DEBT SETTLEMENT AND ELIMINATION (U.S. CLS. 100, 101 AND 102).

FIRST USE 3-0-2010; IN COMMERCE 4-0-2010.

**CLASS 45—PERSONAL AND LEGAL SERVICES**

FOR REPRESENTATION OF CLIENTS IN TAX MATTERS BEFORE TAX AUTHORITIES (U.S. CLS. 100 AND 101).

FIRST USE 3-0-2010; IN COMMERCE 4-0-2010.

3,942,443. LUBRICATION SPECIALTIES, MOUNT GILEAD, OH. SN 85-129,971. FILED 9-15-2010.

**Lubrication Specialties  
Inc.**

THE MARK CONSISTS OF STANDARD CHARACTERS WITHOUT CLAIM TO ANY PARTICULAR FONT, STYLE, SIZE, OR COLOR.

NO CLAIM IS MADE TO THE EXCLUSIVE RIGHT TO USE "INC.", APART FROM THE MARK AS SHOWN.

**CLASS 4—LUBRICANTS AND FUELS**

FOR ALL PURPOSE LUBRICANTS; INDUSTRIAL AND VEHICULAR LUBRICANTS (U.S. CLS. 1, 6 AND 15).

FIRST USE 10-1-1997; IN COMMERCE 10-1-1997.

**CLASS 35—ADVERTISING AND BUSINESS**

FOR RETAIL STORE AND ON-LINE RETAIL STORE SERVICES FEATURING HIGH PERFORMANCE LUBRICATION PRODUCTS (U.S. CLS. 100, 101 AND 102).

FIRST USE 10-1-1997; IN COMMERCE 10-1-1997.

3,942,440. COMMUNITY TAX RELIEF, LLC, CHICAGO, IL. SN 85-124,338. FILED P.R. 9-7-2010; AM. S.R. 1-21-2011.

**Community Tax Relief**

THE MARK CONSISTS OF STANDARD CHARACTERS WITHOUT CLAIM TO ANY PARTICULAR FONT, STYLE, SIZE, OR COLOR.

NO CLAIM IS MADE TO THE EXCLUSIVE RIGHT TO USE "TAX RELIEF", APART FROM THE MARK AS SHOWN.

\* \* \* \* \*

## SECTION 2.— INTERNATIONAL CLASSIFICATION

The short titles associated below with the international class numbers are terms designed merely for quick identification and are not an official part of the international classification. The full names of international classes are given in section 6.1 of the trademark rules of practice.

The designation "U.S. Cl." appearing in this section refers to the U.S. class in effect prior to Sep. 1, 1973 rather than the international class which applies to applications filed on or after that date. For adoption of international classification see notice in the OFFICIAL GAZETTE of Jun. 26, 1973 (911 O.G. TM 210).

### Application in one class

#### CLASS 1—CHEMICALS

3,942,332. ZAKOR LLC, TAMPA, FL. SN 77-562,651. FILED P.R. 9-4-2008; AM. S.R. 1-27-2011.

**PYUR**

THE MARK CONSISTS OF STANDARD CHARACTERS WITHOUT CLAIM TO ANY PARTICULAR FONT, STYLE, SIZE, OR COLOR.

FOR ANTIOXIDANTS AND PROTEINS USED IN THE MANUFACTURE OF COSMETICS, BEVERAGES, FOOD PRODUCTS AND FOOD SUPPLEMENTS; DISTILLED WATER; OXYGENATED DISTILLED WATER (U.S. CLS. 1, 5, 6, 10, 26 AND 46).

FIRST USE 4-6-2008; IN COMMERCE 2-4-2009.

#### CLASS 3—(Continued).

3,942,327. VBS ONLINE, INC., MILWAUKEE, WI. SN 76-695,904. FILED P.R. 2-23-2009; AM. S.R. 3-3-2011.

### BLACK HAIR SPRAY

NO CLAIM IS MADE TO THE EXCLUSIVE RIGHT TO USE "HAIR SPRAY", APART FROM THE MARK AS SHOWN.

FOR HAIR AND SKIN CARE PREPARATIONS, NAMELY, SHAMPOOS, COLOR SHAMPOO, SOAPS, CONDITIONERS, SKIN AND HAIR MOISTURIZERS, HAIR RINSES, BODY MISTS, THERMAL PROTECTIVE SPRAYS, SPRAY SKIN AND HAIR CONDITIONERS, HAIR GELS, HAIR GELS IN SPRAY FORM, SCULPTING FOAM FOR HAIR, LOTIONS FOR HAIR AND SKIN, HAIR STYLING SERUM, HAIR STYLING SPRAYS, STYLING GELS, STYLING LOTIONS, HAIR STRAIGHTENING CREAMS, HAIR SPRAYS, POMADES, HAIR STYLING PREPARATIONS, HAIR SHINE SPRAYS, HAIR SHINE DROPS, WAXES, HAIR COLOR, HAIR DYES, HAIR TINTS, HAIR LIGHTENERS, SEMI-PERMANENT AND PERMANENT HAIR COLOR, HAIR BLEACHES, HAIR STRENGTHENING PREPARATIONS, HAIR RELAXING PREPARATIONS, HAIR STRAIGHTENING PREPARATIONS, PERMANENT WAVING SOLUTIONS, SKIN CARE PRODUCTS, NAMELY, LIQUID SOAPS, BAR SOAPS, SHAVING GELS (U.S. CLS. 1, 4, 6, 50, 51 AND 52).

FIRST USE 7-20-2009; IN COMMERCE 7-20-2009.

3,942,362. JOHN PAUL MITCHELL SYSTEMS, SAUGUS, CA. SN 77-911,847. FILED P.R. 1-14-2010; AM. S.R. 8-2-2010.

### KERATIN INTENSIVE TREATMENT

THE MARK CONSISTS OF STANDARD CHARACTERS WITHOUT CLAIM TO ANY PARTICULAR FONT, STYLE, SIZE, OR COLOR.

NO CLAIM IS MADE TO THE EXCLUSIVE RIGHT TO USE "TREATMENT", APART FROM THE MARK AS SHOWN.

FOR HAIR CONDITIONER MADE IN WHOLE OR SUBSTANTIAL PART OF KERATIN (U.S. CLS. 1, 4, 6, 50, 51 AND 52).

FIRST USE 8-1-2010; IN COMMERCE 8-1-2010.

#### CLASS 3—COSMETICS AND CLEANING PREPARATIONS

**CLASS 5—PHARMACEUTICALS**

3,942,400. BONNIE'S BALMS INC., AKA BONNIE'S BALMS INC., WHEAT RIDGE, CO. AND RICHARD SQUIRE, WHEAT RIDGE, CO. SN 85-022,471. FILED P.R. 4-24-2010; AM. S.R. 1-12-2011.

# Pain Eraser

THE MARK CONSISTS OF STANDARD CHARACTERS WITHOUT CLAIM TO ANY PARTICULAR FONT, STYLE, SIZE, OR COLOR.

FOR PREPARATIONS FOR THE RELIEF OF PAIN, NAMELY, NATURAL TOPICAL PAIN RELIEVING BODY OIL (U.S. CLS. 6, 18, 44, 46, 51 AND 52).

FIRST USE 11-1-2008; IN COMMERCE 1-16-2009.

3,942,453. GENSO LLC, ROSELLE, NJ. SN 85-148,548. FILED P.R. 10-8-2010; AM. S.R. 2-1-2011.

# HEART JUICE

THE MARK CONSISTS OF STANDARD CHARACTERS WITHOUT CLAIM TO ANY PARTICULAR FONT, STYLE, SIZE, OR COLOR.

NO CLAIM IS MADE TO THE EXCLUSIVE RIGHT TO USE "JUICE", APART FROM THE MARK AS SHOWN.

FOR DIETARY SUPPLEMENT BEVERAGE FOR HEART AND GENERAL HEALTH; DIETARY SUPPLEMENTAL DRINKS; DIETARY SUPPLEMENTAL DRINKS IN THE NATURE OF VITAMIN AND MINERAL BEVERAGES; DIETARY SUPPLEMENTS FOR HUMAN CONSUMPTION; DIETARY SUPPLEMENTS FOR HEART AND GENERAL HEALTH; LIQUID NUTRITIONAL SUPPLEMENT; NATURAL HERBAL SUPPLEMENTS; NUTRACEUTICALS FOR USE AS A DIETARY SUPPLEMENT; NUTRITIONAL SUPPLEMENTS FOR PROMOTING HEART AND GENERAL HEALTH (U.S. CLS. 6, 18, 44, 46, 51 AND 52).

FIRST USE 4-0-2009; IN COMMERCE 4-0-2009.

**CLASS 6—METAL GOODS**

3,942,352. THE METRAFLEX COMPANY, CHICAGO, IL. SN 77-858,256. FILED P.R. 10-27-2009; AM. S.R. 12-22-2010.

# V-FLEX

THE MARK CONSISTS OF STANDARD CHARACTERS WITHOUT CLAIM TO ANY PARTICULAR FONT, STYLE, SIZE, OR COLOR.

**CLASS 6—(Continued).**

OWNER OF U.S. REG. NOS. 1,808,800, 2,604,439, AND 3,383,969.

FOR METAL EXPANSION JOINTS FOR PIPING AND DUCTING (U.S. CLS. 2, 12, 13, 14, 23, 25 AND 50).  
FIRST USE 12-15-2010; IN COMMERCE 12-15-2010.

3,942,353. THE METRAFLEX COMPANY, CHICAGO, IL. SN 77-858,281. FILED P.R. 10-27-2009; AM. S.R. 2-1-2011.

# LOOP60

THE MARK CONSISTS OF STANDARD CHARACTERS WITHOUT CLAIM TO ANY PARTICULAR FONT, STYLE, SIZE, OR COLOR.

FOR METAL EXPANSION JOINTS FOR PIPING AND DUCTING (U.S. CLS. 2, 12, 13, 14, 23, 25 AND 50).  
FIRST USE 2-16-2011; IN COMMERCE 2-16-2011.

3,942,386. AXXIOM MANUFACTURING, INC., FRESNO, TX. SN 85-012,115. FILED P.R. 4-12-2010; AM. S.R. 1-27-2011.

# MICROVALVE

THE MARK CONSISTS OF STANDARD CHARACTERS WITHOUT CLAIM TO ANY PARTICULAR FONT, STYLE, SIZE, OR COLOR.

FOR MANUALLY OPERATED, METAL CONTROL VALVES FOR REGULATING THE FLOW OF ABRASIVE MEDIA FOR USE IN THE ABRASIVE BLASTING FIELD (U.S. CLS. 2, 12, 13, 14, 23, 25 AND 50).

FIRST USE 9-30-2008; IN COMMERCE 9-30-2008.

**CLASS 7—MACHINERY**

3,942,338. SEARS BRANDS, LLC, HOFFMAN ESTATES, IL. SN 77-730,518. FILED P.R. 5-6-2009; AM. S.R. 2-7-2011.

# COLD CLEAN

THE MARK CONSISTS OF STANDARD CHARACTERS WITHOUT CLAIM TO ANY PARTICULAR FONT, STYLE, SIZE, OR COLOR.

FOR APPLIANCES, NAMELY, CLOTHES WASHING MACHINES (U.S. CLS. 13, 19, 21, 23, 31, 34 AND 35).  
FIRST USE 9-0-2010; IN COMMERCE 9-0-2010.

**CLASS 7—(Continued).**

3,942,458. BRADY, KEVIN DOUGLAS, JONESBORO, AR. SN 85-156,548. FILED P.R. 10-19-2010; AM. S.R. 2-2-2011.



NO CLAIM IS MADE TO THE EXCLUSIVE RIGHT TO USE "SCRUB", APART FROM THE MARK AS SHOWN.

THE MARK CONSISTS OF THE WORDING "SQUARE SCRUB" IN A STYLIZED FONT WHERE A LARGE "S" APPEARS ON THE LEFT AND THE LETTERS "QUARE" APPEAR ON TOP OF "CRUB".

FOR FLOOR SCRUBBING MACHINES (U.S. CLS. 13, 19, 21, 23, 31, 34 AND 35).

FIRST USE 1-1-2009; IN COMMERCE 10-1-2009.

**CLASS 8—HAND TOOLS**

3,942,351. SCUBA TOOLS, INC., GREENSBORO, NC. SN 77-855,355. FILED P.R. 10-22-2009; AM. S.R. 2-1-2011.



THE MARK CONSISTS OF STANDARD CHARACTERS WITHOUT CLAIM TO ANY PARTICULAR FONT, STYLE, SIZE, OR COLOR.

NO CLAIM IS MADE TO THE EXCLUSIVE RIGHT TO USE "TOOLS", APART FROM THE MARK AS SHOWN.

FOR HAND-OPERATED TOOLS FOR REPAIR OF SCUBA REGULATORS (U.S. CLS. 23, 28 AND 44).

FIRST USE 4-0-2008; IN COMMERCE 4-0-2008.

**CLASS 8—(Continued).**

3,942,365. BROWN INNOVATION GROUP, INC., SALT LAKE CITY, UT. SN 77-934,861. FILED P.R. 2-12-2010; AM. S.R. 6-23-2010.



THE MARK CONSISTS OF STANDARD CHARACTERS WITHOUT CLAIM TO ANY PARTICULAR FONT, STYLE, SIZE, OR COLOR.

FOR CUTLERY, NAMELY, FORKS HAVING CHOP-STICK HANDLES (U.S. CLS. 23, 28 AND 44).

FIRST USE 6-1-2010; IN COMMERCE 6-1-2010.

**CLASS 9—ELECTRICAL AND SCIENTIFIC APPARATUS**

3,942,350. SCUBA TOOLS, INC., GREENSBORO, NC. SN 77-855,335. FILED P.R. 10-22-2009; AM. S.R. 2-1-2011.



NO CLAIM IS MADE TO THE EXCLUSIVE RIGHT TO USE "TOOLS", APART FROM THE MARK AS SHOWN.

FOR HAND-OPERATED TOOLS FOR REPAIR OF SCUBA REGULATORS (U.S. CLS. 21, 23, 26, 36 AND 38).

FIRST USE 4-0-2008; IN COMMERCE 4-0-2008.

3,942,387. SCOTT JURK, GEORGETOWN, TX. SN 85-014,834. FILED P.R. 4-15-2010; AM. S.R. 1-19-2011.



THE MARK CONSISTS OF STANDARD CHARACTERS WITHOUT CLAIM TO ANY PARTICULAR FONT, STYLE, SIZE, OR COLOR.

FOR COMPUTER SOFTWARE FOR SCORING WILD GAME (U.S. CLS. 21, 23, 26, 36 AND 38).

FIRST USE 10-26-2005; IN COMMERCE 12-1-2005.

**CLASS 9—(Continued).**

3,942,401. SMART TECHNOLOGIES ULC, CALGARY, ALBERTA, CANADA. SN 85-025,576. FILED P.R. 4-28-2010; AM. S.R. 1-10-2011.

SMART RESPONSE

THE MARK CONSISTS OF STANDARD CHARACTERS WITHOUT CLAIM TO ANY PARTICULAR FONT, STYLE, SIZE, OR COLOR.

PRIORITY CLAIMED UNDER SEC. 44(D) ON CANADA APPLICATION NO. 1457113, FILED 10-28-2009.

OWNER OF U.S. REG. NO. 3,289,303.

FOR COMPUTER HARDWARE, NAMELY, A HANDHELD COMPUTER WITH INTEGRATED HARDWARE; SOFTWARE, NAMELY, INTERACTIVE ASSESSMENT SOFTWARE, COMPRISED OF SOFTWARE TO GENERATE AND TRANSMIT INFORMATION, NAMELY, QUESTIONS/ANSWERS (U.S. CLS. 21, 23, 26, 36 AND 38).  
FIRST USE 1-14-2009; IN COMMERCE 1-14-2009.

3,942,403. ABYSS GROUP INC, STAMFORD, CT. SN 85-029,269. FILED P.R. 5-3-2010; AM. S.R. 2-18-2011.

iAUDIT

THE MARK CONSISTS OF STANDARD CHARACTERS WITHOUT CLAIM TO ANY PARTICULAR FONT, STYLE, SIZE, OR COLOR.

FOR COMPUTER SOFTWARE FOR DATA AUDITING, VERIFICATION, INTEGRITY OF DATA BETWEEN MORE THAN ONE DATABASE OR SYSTEMS. DATA COLLECTION, PROMOTING DATA CONSISTENCY AND ASSISTING WITH INTERNAL AND EXTERNAL DATA QUALITY AUDITS (U.S. CLS. 21, 23, 26, 36 AND 38).

FIRST USE 4-28-2010; IN COMMERCE 4-28-2010.

**CLASS 9—(Continued).**

3,942,405. FLATIRONS SOLUTIONS CORPORATION, BOULDER, CO. SN 85-037,424. FILED P.R. 5-13-2010; AM. S.R. 2-2-2011.

iCMS

THE MARK CONSISTS OF STANDARD CHARACTERS WITHOUT CLAIM TO ANY PARTICULAR FONT, STYLE, SIZE, OR COLOR.

FOR COMPUTER APPLICATION SOFTWARE FOR MOBILE PHONES, NAMELY, SOFTWARE FOR ACCESSING CONTENT MANAGEMENT SYSTEMS (U.S. CLS. 21, 23, 26, 36 AND 38).

FIRST USE 4-15-2010; IN COMMERCE 4-26-2010.

3,942,424. NEOPOST USA INC., MILFORD, CT. SN 85-076,334. FILED P.R. 7-1-2010; AM. S.R. 2-16-2011.

iMeter

THE MARK CONSISTS OF STANDARD CHARACTERS WITHOUT CLAIM TO ANY PARTICULAR FONT, STYLE, SIZE, OR COLOR.

FOR APPARATUSES FOR MONITORING POSTAL FRANKING, NAMELY, MICROPROCESSOR-BASED POSTAGE METERS; BAR-CODE READERS; SOFTWARE FOR MAIL PROCESSING, NAMELY, FOR GENERATING AND MANAGING THE SENDING AND SHIPPING OF MAIL, THE FRANKING THEREOF, PROCESSING OF ALL THE CORRESPONDING DOCUMENTS, THE TRACKING AND TRACING OF MAIL, AND TO THE ACCOUNTING OF THE COSTS RELATED THERETO; APPARATUS, INSTRUMENTS, MEMBERS AND DEVICES FOR GENERATING, CALCULATING, MONITORING, INPUTTING, STORING, CONVERTING, PROCESSING, SAMPLING, TRANSMITTING, SWITCHING, AND RECEIVING DATA, INFORMATION, SIGNALS OR MESSAGES RELATING TO PROCESSING MAIL, SHIPPING, TRACKING AND TRACING OF MAIL, AND TO THE ACCOUNTING OF THE COSTS RELATED THERETO; POSTAGE METERS; WEIGHING PLATFORMS USED IN CONJUNCTION WITH POSTAGE METERS; COMPUTERS AND PERIPHERALS THEREFOR, AND IN PARTICULAR PRINTERS; AND PARTS THEREFOR (U.S. CLS. 21, 23, 26, 36 AND 38).

FIRST USE 2-15-2011; IN COMMERCE 2-15-2011.

**CLASS 9—(Continued).**

3,942,425. HANDI QUILTER, INC., NORTH SALT LAKE, UT.  
SN 85-078,748. FILED P.R. 7-6-2010; AM. S.R. 2-1-2011.

**HANDI QUILTER**

THE MARK CONSISTS OF STANDARD CHARACTERS WITHOUT CLAIM TO ANY PARTICULAR FONT, STYLE, SIZE, OR COLOR.

OWNER OF U.S. REG. NOS. 2,920,821, 3,559,066, AND OTHERS.

NO CLAIM IS MADE TO THE EXCLUSIVE RIGHT TO USE "QUILTER", APART FROM THE MARK AS SHOWN.

FOR PRERECORDED VIDEOS AND DVDS FEATURING QUILTING (U.S. CLS. 21, 23, 26, 36 AND 38).

FIRST USE 9-29-2008; IN COMMERCE 9-29-2008.

---

3,942,429. ARNAUTOVICH, ANDREY ASIMOVICH, SAINT-PETERSBURG, RUSSIAN FED.. SN 85-084,644. FILED P.R. 7-14-2010; AM. S.R. 1-31-2011.

**AnyFileBackup**

THE MARK CONSISTS OF STANDARD CHARACTERS WITHOUT CLAIM TO ANY PARTICULAR FONT, STYLE, SIZE, OR COLOR.

FOR COMPUTER SOFTWARE FOR DATA BACKUP, REPLICATION, SYNCHRONIZATION (U.S. CLS. 21, 23, 26, 36 AND 38).

FIRST USE 7-14-2010; IN COMMERCE 7-14-2010.

---

3,942,433. COALITION OF BONE HEALTH EDUCATORS, LLC, MONROE TOWNSHIP, NJ. SN 85-104,491. FILED P.R. 8-10-2010; AM. S.R. 1-3-2011.

**COALITION OF BONE HEALTH EDUCATORS**

THE MARK CONSISTS OF STANDARD CHARACTERS WITHOUT CLAIM TO ANY PARTICULAR FONT, STYLE, SIZE, OR COLOR.

NO CLAIM IS MADE TO THE EXCLUSIVE RIGHT TO USE "BONE", APART FROM THE MARK AS SHOWN.

FOR PROVIDING DOWNLOADABLE ELECTRONIC MAGAZINES, JOURNALS, NEWSLETTERS, FEATURE REPORTS, MONOGRAPHS AND SUPPLEMENTS IN THE FIELDS OF OSTEOPATHY, BONE DISEASE, OSTEOPOROSIS, BONE DENSITY, PHARMACY, NURSING AND MEDICINE (U.S. CLS. 21, 23, 26, 36 AND 38).

FIRST USE 8-1-2009; IN COMMERCE 2-11-2010.

**CLASS 9—(Continued).**

3,942,451. CLOUD SAFE BACKUP, LLC, CAMARILLO, CA.  
SN 85-148,307. FILED P.R. 10-8-2010; AM. S.R. 2-1-2011.

**CLOUD SAFE BACKUP**

THE MARK CONSISTS OF STANDARD CHARACTERS WITHOUT CLAIM TO ANY PARTICULAR FONT, STYLE, SIZE, OR COLOR.

FOR COMPUTER STORAGE DEVICES, NAMELY, HIGH-SPEED STORAGE SUBSYSTEMS FOR STORAGE AND BACKUP OF ELECTRONIC DATA EITHER LOCALLY OR VIA A TELECOMMUNICATIONS NETWORK (U.S. CLS. 21, 23, 26, 36 AND 38).

FIRST USE 4-27-2010; IN COMMERCE 4-27-2010.

**CLASS 10—MEDICAL APPARATUS**

3,942,431. PALOMAR MEDICAL TECHNOLOGIES, INC., BURLINGTON, MA. SN 85-103,104. FILED P.R. 8-9-2010; AM. S.R. 1-28-2011.

**SKIN RENEWING LASER**

THE MARK CONSISTS OF STANDARD CHARACTERS WITHOUT CLAIM TO ANY PARTICULAR FONT, STYLE, SIZE, OR COLOR.

NO CLAIM IS MADE TO THE EXCLUSIVE RIGHT TO USE "LASER", APART FROM THE MARK AS SHOWN.

FOR LIGHT-BASED DEVICES FOR MEDICAL, DERMATOLOGICAL, AND COSMETIC TREATMENT OF THE BODY (U.S. CLS. 26, 39 AND 44).

FIRST USE 12-27-2010; IN COMMERCE 12-27-2010.

**CLASS 11—ENVIRONMENTAL CONTROL APPARATUS**



**CLASS 11—(Continued).**

3,942,402. HOT-CAN SDN. BHD., KUALA LUMPUR, MALAYSIA. SN 85-025,956. FILED P.R. 4-29-2010; AM. S.R. 2-8-2011.

# HOT-CAN

THE MARK CONSISTS OF STANDARD CHARACTERS WITHOUT CLAIM TO ANY PARTICULAR FONT, STYLE, SIZE, OR COLOR.

FOR SELF HEATING CONTAINERS MADE PRIMARILY OF METAL FOR SINGLE SERVINGS OF BEVERAGES (U.S. CLS. 13, 21, 23, 31 AND 34).

FIRST USE 2-2-2011; IN COMMERCE 2-2-2011.

3,942,407. TRS QUALITY, INC., FT. WORTH, TX. SN 85-040,644. FILED P.R. 5-17-2010; AM. S.R. 2-12-2011.



THE COLOR(S) BLACK, GREEN AND SILVER IS/ARE CLAIMED AS A FEATURE OF THE MARK.

THE MARK CONSISTS OF A DESIGN APPEARING ON THE PACKAGING FOR THE GOODS AND IS DIVIDED INTO THREE SECTIONS. THE BOTTOM SECTION OF THE PACKAGING APPEARS IN THE COLOR BLACK. THE MIDDLE SECTION OF THE PACKAGING APPEARS IN THE COLOR GREEN AND HAS A STRAIGHT BOTTOM EDGE AND WAVY TOP EDGE. THE TOP SECTION OF THE PACKAGING APPEARS IN THE COLOR BLACK WITH SILVER SHADING AND HAS A STRAIGHT TOP EDGE AND WAVY BOTTOM EDGE. IN BETWEEN THE TOP AND MIDDLE SECTIONS OF THE PACKAGING IS A WAVY SILVER LINE. THE DOTTED OUTLINE IN THE MARK IS INTENDED TO SHOW THE POSITION OF THE MARK ON THE PACKAGING FOR THE GOODS AND IS NOT PART OF THE MARK.

FOR SPOTLIGHTS, FLASHLIGHTS (U.S. CLS. 13, 21, 23, 31 AND 34).

FIRST USE 10-0-2009; IN COMMERCE 10-0-2009.

**CLASS 14—JEWELRY****CLASS 14—(Continued).**

3,942,378. DAMIANI INTERNATIONAL B.V., AMSTERDAM, HOLLAND, NETHERLANDS. SN 78-875,414. FILED P.R. 5-3-2006; AM. S.R. 3-3-2008.

# SALVINI

THE MARK CONSISTS OF STANDARD CHARACTERS WITHOUT CLAIM TO ANY PARTICULAR FONT, STYLE, SIZE, OR COLOR.

PRIORITY CLAIMED UNDER SEC. 44(D) ON ERPNCMNTY TM OFC APPLICATION NO. 4980991, FILED 3-27-2006, REG. NO. 004980991, DATED 4-30-2010, EXPIRES 3-27-2016.

FOR JEWELRY; BELT BUCKLES OF PRECIOUS METALS; BRACELETS OF PRECIOUS METALS; BROOCHES; CUFF-LINKS; DIAMONDS; EARRINGS; NECKLACES; PEARLS; PRECIOUS METALS AND THEIR ALLOYS; RINGS; BRACELETS; CHARMS; EARRINGS IN PRECIOUS METAL OR COATED THEREWITH; AND PRECIOUS STONES (U.S. CLS. 2, 27, 28 AND 50).

FIRST USE 9-14-2005; IN COMMERCE 9-14-2005.

**CLASS 16—PAPER GOODS AND PRINTED MATTER**

3,942,367. CRAYOLA PROPERTIES, INC., EASTON, PA. SN 77-940,295. FILED P.R. 2-19-2010; AM. S.R. 2-24-2011.

# BITTERSWEET SHIMMER

THE MARK CONSISTS OF STANDARD CHARACTERS WITHOUT CLAIM TO ANY PARTICULAR FONT, STYLE, SIZE, OR COLOR.

OWNER OF U.S. REG. NO. 3,414,037. FOR CRAYONS (U.S. CLS. 2, 5, 22, 23, 29, 37, 38 AND 50).

FIRST USE 1-18-2001; IN COMMERCE 1-18-2001.

3,942,369. CRAYOLA PROPERTIES, INC., EASTON, PA. SN 77-941,482. FILED P.R. 2-22-2010; AM. S.R. 2-24-2011.

# METALLIC SUNBURST

THE MARK CONSISTS OF STANDARD CHARACTERS WITHOUT CLAIM TO ANY PARTICULAR FONT, STYLE, SIZE, OR COLOR.

**CLASS 16—(Continued).**

NO CLAIM IS MADE TO THE EXCLUSIVE RIGHT TO USE "METALLIC", APART FROM THE MARK AS SHOWN.  
FOR CRAYONS (U.S. CLS. 2, 5, 22, 23, 29, 37, 38 AND 50).  
FIRST USE 1-18-2001; IN COMMERCE 1-18-2001.

---

3,942,382. WORLDTAG HOLDINGS INC. AKA WORLDTAG.COM, PEEKSKILL, NY. SN 85-007,565. FILED P.R. 4-6-2010; AM. S.R. 1-21-2011.

print peel apply

THE MARK CONSISTS OF STANDARD CHARACTERS WITHOUT CLAIM TO ANY PARTICULAR FONT, STYLE, SIZE, OR COLOR.  
FOR ADHESIVE LABELS; BLANK OR PARTIALLY PRINTED PAPER LABELS; LABEL PAPER; PAPER LABELS; SHIPPING LABELS (U.S. CLS. 2, 5, 22, 23, 29, 37, 38 AND 50).  
FIRST USE 6-1-2009; IN COMMERCE 6-1-2009.

---

3,942,426. HANDI QUILTER, INC., NORTH SALT LAKE, UT. SN 85-078,769. FILED P.R. 7-6-2010; AM. S.R. 2-1-2011.

HANDI QUILTER

THE MARK CONSISTS OF STANDARD CHARACTERS WITHOUT CLAIM TO ANY PARTICULAR FONT, STYLE, SIZE, OR COLOR.  
OWNER OF U.S. REG. NOS. 2,920,821, 3,559,066, AND OTHERS.  
NO CLAIM IS MADE TO THE EXCLUSIVE RIGHT TO USE "QUILTER", APART FROM THE MARK AS SHOWN.  
FOR EDUCATIONAL BOOKS AND MANUALS ON QUILTING TECHNIQUES (U.S. CLS. 2, 5, 22, 23, 29, 37, 38 AND 50).  
FIRST USE 5-3-2007; IN COMMERCE 5-3-2007.

**CLASS 16—(Continued).**

3,942,432. COALITION OF BONE HEALTH EDUCATORS, LLC, MONROE TOWNSHIP, NJ. SN 85-104,444. FILED P.R. 8-10-2010; AM. S.R. 1-3-2011.

COALITION OF BONE HEALTH  
EDUCATORS

THE MARK CONSISTS OF STANDARD CHARACTERS WITHOUT CLAIM TO ANY PARTICULAR FONT, STYLE, SIZE, OR COLOR.

NO CLAIM IS MADE TO THE EXCLUSIVE RIGHT TO USE "BONE", APART FROM THE MARK AS SHOWN.  
FOR PRINTED PUBLICATIONS, NAMELY, PEER-REVIEWED MAGAZINES, JOURNALS, NEWSLETTERS, FEATURE REPORTS, MONOGRAPHS AND PRINTED SUPPLEMENTS IN THE FIELDS OF OSTEOPATHY, BONE DISEASE, OSTEOPOROSIS, BONE DENSITY, PHARMACY, NURSING AND MEDICINE (U.S. CLS. 2, 5, 22, 23, 29, 37, 38 AND 50).  
FIRST USE 8-1-2009; IN COMMERCE 2-11-2010.

**CLASS 18—LEATHER GOODS**

3,942,410. GALT, LLC, WARREN, PA. SN 85-046,936. FILED P.R. 5-25-2010; AM. S.R. 2-22-2011.

GALT

THE MARK CONSISTS OF STANDARD CHARACTERS WITHOUT CLAIM TO ANY PARTICULAR FONT, STYLE, SIZE, OR COLOR.

FOR LUGGAGE, TOTE-BAGS, WALLETS, AND SMALL LEATHER GOODS, NAMELY, KEY CHAINS AND LUGGAGE TAGS (U.S. CLS. 1, 2, 3, 22 AND 41).  
FIRST USE 11-26-2009; IN COMMERCE 12-1-2009.

**CLASS 19—NON-METALLIC BUILDING MATERIALS**

**CLASS 19—(Continued).**

3,942,366. RICHMOND PLYWOOD CORPORATION LIMITED, RICHMOND, CANADA. SN 77-940,063. FILED 2-19-2010.

**HIGH FLOW**

THE MARK CONSISTS OF STANDARD CHARACTERS WITHOUT CLAIM TO ANY PARTICULAR FONT, STYLE, SIZE, OR COLOR.  
FOR BUILDING MATERIAL, NAMELY, PLYWOOD (U.S. CLS. 1, 12, 33 AND 50).  
FIRST USE 9-0-2009; IN COMMERCE 9-0-2009.

**CLASS 20—FURNITURE AND ARTICLES NOT OTHERWISE CLASSIFIED**

3,942,337. MODERN OUTDOOR DESIGNS, LLC, DBA MODERN OUTDOOR, CULVER CITY, CA. SN 77-703,556. FILED 3-31-2009.

**MODERNOUTDOOR**

THE MARK CONSISTS OF STANDARD CHARACTERS WITHOUT CLAIM TO ANY PARTICULAR FONT, STYLE, SIZE, OR COLOR.  
FOR FURNITURE FOR HOUSE, OFFICE AND GARDEN (U.S. CLS. 2, 13, 22, 25, 32 AND 50).  
FIRST USE 3-1-2003; IN COMMERCE 5-1-2006.

3,942,398. PALMER SNYDER FURNITURE COMPANY, MILWAUKEE, WI. SN 85-019,835. FILED P.R. 4-21-2010; AM. S.R. 1-26-2011.

**Portable. Stackable.  
Storable.**

THE MARK CONSISTS OF STANDARD CHARACTERS WITHOUT CLAIM TO ANY PARTICULAR FONT, STYLE, SIZE, OR COLOR.  
FOR CHAIRS (U.S. CLS. 2, 13, 22, 25, 32 AND 50).  
FIRST USE 11-1-2008; IN COMMERCE 11-1-2008.

**CLASS 20—(Continued).**

3,942,427. KINGSDOWN, INC., MEBANE, NC. SN 85-080,217. FILED P.R. 7-8-2010; AM. S.R. 2-18-2011.

**THERMAL TRANSFER TECHNOLOGY**

THE MARK CONSISTS OF STANDARD CHARACTERS WITHOUT CLAIM TO ANY PARTICULAR FONT, STYLE, SIZE, OR COLOR.  
FOR MATTRESSES AND BOX SPRINGS (U.S. CLS. 2, 13, 22, 25, 32 AND 50).  
FIRST USE 6-9-2010; IN COMMERCE 2-16-2011.

**CLASS 21—HOUSEWARES AND GLASS**

3,942,331. HORTECH, INC., SPRING LAKE, MI. SN 77-498,717. FILED P.R. 6-13-2008; AM. S.R. 5-17-2010.

**LiveRoof**

THE MARK CONSISTS OF STANDARD CHARACTERS WITHOUT CLAIM TO ANY PARTICULAR FONT, STYLE, SIZE, OR COLOR.  
OWNER OF U.S. REG. NO. 3,099,383.  
FOR PLANTERS FOR PLANTS (U.S. CLS. 2, 13, 23, 29, 30, 33, 40 AND 50).  
FIRST USE 7-0-2005; IN COMMERCE 7-0-2005.

3,942,335. DISNEY ENTERPRISES, INC., BURBANK, CA. SN 77-654,449. FILED P.R. 1-22-2009; AM. S.R. 2-18-2011.

**GERONIMO JACKSON**

THE MARK CONSISTS OF STANDARD CHARACTERS WITHOUT CLAIM TO ANY PARTICULAR FONT, STYLE, SIZE, OR COLOR.  
THE NAME(S), PORTRAIT(S), AND/OR SIGNATURE(S) SHOWN IN THE MARK DOES NOT IDENTIFY A PARTICULAR LIVING INDIVIDUAL.  
FOR COASTERS NOT OF PAPER AND NOT BEING TABLE LINEN (U.S. CLS. 2, 13, 23, 29, 30, 33, 40 AND 50).  
FIRST USE 1-16-2006; IN COMMERCE 1-16-2006.

**CLASS 21—(Continued).**

3,942,460. METROPLEX SERVICES, INC., MASON, OH. SN 85-156,768. FILED P.R. 10-20-2010; AM. S.R. 1-31-2011.

**WINE BALLOON**

THE MARK CONSISTS OF STANDARD CHARACTERS WITHOUT CLAIM TO ANY PARTICULAR FONT, STYLE, SIZE, OR COLOR.

FOR APPARATUS FOR SEALING THE INTERIOR OF A WINE BOTTLE TO PROTECT WINE FROM OXIDATION (U.S. CLS. 2, 13, 23, 29, 30, 33, 40 AND 50).

FIRST USE 9-28-2010; IN COMMERCE 9-28-2010.

**CLASS 25—(Continued).**

3,942,330. PAYLESS SHOESOURCE WORLDWIDE, INC., TOPEKA, KS. SN 77-394,978. FILED P.R. 2-12-2008; AM. S.R. 1-20-2011.



THE MARK CONSISTS OF TWO PARALLEL STRIPES OF VARYING WIDTHS EXTENDING FROM THE LACING AREA TO THE OUTSOLE WITH THE STRIPES SEPARATED BY A REGION OF CONTRAST THAT IS WIDER THAN EACH OF THE STRIPES AND WITH THE LARGER OF THE STRIPES HAVING TWO ZIG-ZAGGED LINES PLACED ON OPPOSITE SIDES WITHIN THE STRIPE. THE SHOE OUTLINE SHOWN IN BROKEN LINES IS NOT A PART OF THE MARK AND IS INCLUDED MERELY TO SHOW THE LOCATION OF THE MARK IN USE.

FOR FOOTWEAR (U.S. CLS. 22 AND 39).  
FIRST USE 2-0-2007; IN COMMERCE 2-0-2007.

**CLASS 22—CORDAGE AND FIBERS**

3,942,441. LOOPROPE, LLC, MEDFORD, OR. SN 85-128,588. FILED P.R. 9-13-2010; AM. S.R. 1-3-2011.

**BUOYROPE**

THE MARK CONSISTS OF STANDARD CHARACTERS WITHOUT CLAIM TO ANY PARTICULAR FONT, STYLE, SIZE, OR COLOR.

FOR BOAT ACCESSORIES, NAMELY, ANCHORING ROPES, MOORING ROPES FOR BOATS AND ROPES FOR SECURING BOAT BUMPERS AND BOAT FENDERS (U.S. CLS. 1, 2, 7, 19, 22, 42 AND 50).

FIRST USE 4-23-2010; IN COMMERCE 4-23-2010.

3,942,340. THOMPSON, RODNEY B, DBA FOE COMPANY, PHILADELPHIA, PA. SN 77-820,721. FILED P.R. 9-4-2009; AM. S.R. 2-24-2011.



NO CLAIM IS MADE TO THE EXCLUSIVE RIGHT TO USE "COMPANY", APART FROM THE MARK AS SHOWN.

THE MARK CONSISTS OF THE WORDING "FOE FREEDOM OF EXPRESSION COMPANY". A WREATH AND TWO STARS APPEAR AROUND THE TERM "FOE".

FOR SHIRTS; SHIRTS AND SHORT-SLEEVED SHIRTS; SHORT-SLEEVED SHIRTS; T-SHIRTS; TEE SHIRTS (U.S. CLS. 22 AND 39).

FIRST USE 6-10-2005; IN COMMERCE 12-19-2008.

**CLASS 25—CLOTHING**

**CLASS 25—(Continued).**

3,942,372. ATCHLEY, KERI B., DBA THE DOGS OF 30A, LLC, DANIELSVILLE, GA. SN 77-958,999. FILED P.R. 3-15-2010; AM. S.R. 6-17-2010.



THE COLOR(S) BLUE AND WHITE IS/ARE CLAIMED AS A FEATURE OF THE MARK.  
THE MARK CONSISTS OF A BLUE CIRCLE WITH A WHITE SILHOUETTE OF A DOG, AND A WHITE SUN AND HORIZON IMAGE. THE WORDS "THE DOGS OF 30A THE DOGS OF 30A.COM" ARE IN WHITE.  
FOR ATHLETIC APPAREL, NAMELY, SHIRTS, PANTS, JACKETS, FOOTWEAR, HATS AND CAPS, ATHLETIC UNIFORMS (U.S. CLS. 22 AND 39).  
FIRST USE 1-1-2010; IN COMMERCE 1-29-2010.

**CLASS 25—(Continued).**

3,942,375. PUREPLAY LLC, GARDEN CITY, NY. SN 77-967,806. FILED P.R. 3-24-2010; AM. S.R. 2-3-2011.



THE COLOR(S) BLUE, YELLOW, RED, ORANGE, LIGHT GREEN, AND DARK GREEN IS/ARE CLAIMED AS A FEATURE OF THE MARK.  
THE MARK CONSISTS OF AN ARRAY OF THREE THREADS OF YARN, EACH THREAD COMPOSED OF BLUE, YELLOW, RED, ORANGE, LIGHT GREEN, AND DARK GREEN FIBERS; THE THREADS ARE POSITIONED ON THE EDGE OF THE POCKET OF THE CLOTHING; THE DOTTED OUTLINE OF THE CLOTHING IS NOT CLAIMED AS PART OF THE MARK AND IS INTENDED ONLY TO SHOW THE POSITION OF THE MARK.  
FOR SWEAT SHIRTS, TEE SHIRTS, TOPS (U.S. CLS. 22 AND 39).  
FIRST USE 5-0-2009; IN COMMERCE 5-0-2009.

3,942,373. MCCOY, MATTHEW, SIMI VALLEY, CA. AND INTESO, GARRETT, SIMI VALLEY, CA. SN 77-962,900. FILED P.R. 3-19-2010; AM. S.R. 1-29-2011.

**BATTLEWOUNDS**

THE MARK CONSISTS OF STANDARD CHARACTERS WITHOUT CLAIM TO ANY PARTICULAR FONT, STYLE, SIZE, OR COLOR.  
FOR CLOTHING, NAMELY, JEANS, PANTS, SHORTS, DRESSES, SKIRTS, SHIRTS, T-SHIRTS, LONG-SLEEVED SHIRTS, DRESS SHIRTS, SWEATSHIRTS, HOODED SWEATSHIRTS, JACKETS, COATS, BELTS, HATS, SOCKS, GLOVES, SHOES, SCARVES, WRISTBANDS, UNDERWEAR, BATHING SUITS, SUITS, TIGHTS, FOOTWEAR, AND HEADWEAR FOR CONSUMERS OF ALL AGES (U.S. CLS. 22 AND 39).  
FIRST USE 1-1-2008; IN COMMERCE 8-1-2009.

3,942,406. EXPRESS, LLC, COLUMBUS, OH. SN 85-040,507. FILED P.R. 5-17-2010; AM. S.R. 2-25-2011.



THE MARK CONSISTS OF A BACK POCKET STITCHING DESIGN, NAMELY, A STYLIZED HEART DESIGN INTERSECTED BY GEOMETRIC FIGURES. THE BACK POCKET APPEARS IN DOTTED LINES TO SHOW THE POSITION OF THE MARK ON THE GOODS AND IS NOT PART OF THE MARK.  
FOR DENIM JEANS (U.S. CLS. 22 AND 39).  
FIRST USE 5-0-2010; IN COMMERCE 5-0-2010.

**CLASS 25—(Continued).**

3,942,448. JERUSALEM SANDALS, SHERMAN OAKS, CA.  
SN 85-143,530. FILED P.R. 10-1-2010; AM. S.R. 2-1-2011.

## Jerusalem Sandals

THE MARK CONSISTS OF STANDARD CHARACTERS WITHOUT CLAIM TO ANY PARTICULAR FONT, STYLE, SIZE, OR COLOR.

NO CLAIM IS MADE TO THE EXCLUSIVE RIGHT TO USE "SANDALS", APART FROM THE MARK AS SHOWN. FOR SANDALS; SHOES (U.S. CLS. 22 AND 39). FIRST USE 1-9-2010; IN COMMERCE 2-18-2010.

3,942,457. BILLION INTERNATIONAL TRADING, INC.,  
SOUTH EL MONTE, CA. SN 85-156,205. FILED P.R. 10-19-  
2010; AM. S.R. 1-31-2011.

## SOHO KIDS

THE MARK CONSISTS OF STANDARD CHARACTERS WITHOUT CLAIM TO ANY PARTICULAR FONT, STYLE, SIZE, OR COLOR.

OWNER OF U.S. REG. NOS. 3,383,608 AND 3,578,179.  
FOR BABY BOTTOMS; BABY TOPS; BATHING COSTUMES; BELTS; CHILDREN'S AND INFANT'S APPAREL, NAMELY, JUMPERS, OVERALL SLEEPWEAR, PAJAMAS, ROMPERS AND ONE-PIECE GARMENTS; CHILDREN'S HEADWEAR; COATS; DRESSES; FOOTWEAR; GLOVES; HATS FOR INFANTS, BABIES, TODDLERS AND CHILDREN; HEADWEAR; JACKETS; JEANS; NECKWEAR; PAJAMAS; PANTIES; PANTS; SCARVES; SHIRTS; SHORTS; SKIRTS; SLEEPWEAR; SOCKS; SWEATERS; SWIMWEAR; TIES; TOPS; T-SHIRTS; AND UNDERWEAR (U.S. CLS. 22 AND 39). FIRST USE 10-12-2010; IN COMMERCE 10-12-2010.

3,942,463. ALEXANDER, KEAWE, HONOLULU, HI. SN 85-  
170,879. FILED P.R. 11-6-2010; AM. S.R. 2-17-2011.

## FANTASY FITNESS UNIVERSITY

THE MARK CONSISTS OF STANDARD CHARACTERS WITHOUT CLAIM TO ANY PARTICULAR FONT, STYLE, SIZE, OR COLOR.

OWNER OF U.S. REG. NOS. 3,160,175, 3,262,993, AND 3,263,227.

**CLASS 25—(Continued).**

NO CLAIM IS MADE TO THE EXCLUSIVE RIGHT TO USE "FITNESS", APART FROM THE MARK AS SHOWN.

FOR CLOTHING, FOOTWEAR AND HEADWEAR, NAMELY, T-SHIRTS, SWEAT SHIRTS, JERSEYS, SHORTS, SWEAT PANTS, JACKETS, HATS, CAPS, SCARVES, GLOVES, HOSIERY, NECKTIES, PAJAMAS, ROBES, NIGHT SHIRTS, NIGHT GOWNS, UNDERWEAR, HEADBANDS, WRIST BANDS, SWIM SUITS, SKIRTS, SHIRTS, TANK TOPS, PANTS, COATS, SWEATERS, LEOTARDS, LEG WARMERS, STOCKINGS, SOCKS, PANTYHOSE, TIGHTS, BELTS, SHOES, ATHLETIC SHOES, SLIPPERS, BOOTS, SANDALS AND RAINWEAR (U.S. CLS. 22 AND 39).

FIRST USE 10-10-2010, THE MARK WAS FIRST USED ANYWHERE IN A DIFFERENT FORM OTHER THAN THAT SOUGHT TO BE REGISTERED AT LEAST AS EARLY AS 05/05/2006. ; IN COMMERCE 10-10-2010, THE MARK WAS FIRST USED IN COMMERCE IN A DIFFERENT FORM OTHER THAN THAT SOUGHT TO BE REGISTERED AT LEAST AS EARLY AS 05/05/2006..

3,942,464. ALEXANDER, KEAWE, HONOLULU, HI. SN 85-  
170,887. FILED P.R. 11-6-2010; AM. S.R. 2-17-2011.

## FFU WHO HAS THE FITTEST STUDENT BODY?

THE MARK CONSISTS OF STANDARD CHARACTERS WITHOUT CLAIM TO ANY PARTICULAR FONT, STYLE, SIZE, OR COLOR.

FOR CLOTHING, FOOTWEAR AND HEADWEAR, NAMELY, T-SHIRTS, SWEAT SHIRTS, JERSEYS, SHORTS, SWEAT PANTS, JACKETS, HATS, CAPS, SCARVES, GLOVES, HOSIERY, NECKTIES, PAJAMAS, ROBES, NIGHT SHIRTS, NIGHT GOWNS, UNDERWEAR, HEAD BANDS, WRIST BANDS, SWIM SUITS, SKIRTS, SHIRTS, TANK TOPS, PANTS, COATS, SWEATERS, LEOTARDS, LEG WARMERS, STOCKINGS, SOCKS, PANTY HOSE, TIGHTS, BELTS, SHOES, ATHLETIC SHOES, SLIPPERS, BOOTS, SANDALS AND RAINWEAR (U.S. CLS. 22 AND 39).

FIRST USE 10-10-2010; IN COMMERCE 10-10-2010.

**CLASS 25—(Continued).**

3,942,465. ALEXANDER, KEAWE, HONOLULU, HI. SN 85-170,889. FILED P.R. 11-6-2010; AM. S.R. 2-17-2011.

# FFU

THE MARK CONSISTS OF STANDARD CHARACTERS WITHOUT CLAIM TO ANY PARTICULAR FONT, STYLE, SIZE, OR COLOR.

FOR CLOTHING, FOOTWEAR AND HEADWEAR, NAMELY, T-SHIRTS, SWEAT SHIRTS, JERSEYS, SHORTS, SWEAT PANTS, JACKETS, HATS, CAPS, SCARVES, GLOVES, HOSIERY, NECKTIES, PAJAMAS, ROBES, NIGHT SHIRTS, NIGHT GOWNS, UNDERWEAR, HEAD BANDS, WRIST BANDS, SWIM SUITS, SKIRTS, SHIRTS, TANK TOPS, PANTS, COATS, SWEATERS, LEOTARDS, LEG WARMERS, STOCKINGS, SOCKS, PANTY HOSE, TIGHTS, BELTS, SHOES, ATHLETIC SHOES, SLIPPERS, BOOTS, SANDALS AND RAINWEAR (U.S. CLS. 22 AND 39).

FIRST USE 10-10-2010; IN COMMERCE 10-10-2010.

3,942,469. JENNIFER J HARTMAN, DBA KENJENS LLC, PORT ST LUCIE, FL. SN 85-177,726. FILED P.R. 11-16-2010; AM. S.R. 2-25-2011.



THE COLOR(S) BLACK, WHITE, PURPLE, RED, GREEN, GRAY IS/ARE CLAIMED AS A FEATURE OF THE MARK.

THE MARK CONSISTS OF A FISH WITH A PURPLE MOHAWK OUTLINED BY BLACK, BLACK SUN GLASSES WITH A SPOT OF WHITE IN THE UPPER RIGHT LENS, RED LIPS OUTLINED BY BLACK, A GREEN AND WHITE BODY WITH A BLACK TRIBAL STRIPE DOWN HIS SIDE, GREEN FINS OUTLINED BY BLACK ON BOTH SIDES OF HIS BODY, AND A GREEN TAIL OUTLINED BY BLACK, A GREEN FIN ON HIS BACK OUTLINED BY BLACK, A WHITE UNDERBODY ACCENTED BY SMALL BLACK FINS AND A GRAY SHADOWING ALONG THE BOTTOM, ABOVE THE FISH IS THE WORD BADAZZBASS IN BLACK BOLD LETTERING, BELOW THE FISH ARE TWO WAVES, THE TOP ONE GREEN, THE BOTTOM PURPLE, BOTH OUTLINED COMPLETELY IN BLACK, THEY CURVE UP UNDER THE BODY OF THE FISH, AND TWO SPLASH MARKS ON EACH SIDE OF THE FISH, THE TWO CLOSEST TO THE BODY ARE GREEN WITH BLACK OUTLINING, AND THE TWO ON THE OUTSIDE OF THOSE ARE PURPLE WITH BLACK OUTLINING.

FOR HATS; SHIRTS AND SHORT-SLEEVED SHIRTS (U.S. CLS. 22 AND 39).

FIRST USE 0-0-2007; IN COMMERCE 0-0-2007.

**CLASS 27—FLOOR COVERINGS**

3,942,360. AMERICAN GARAGE, LLC, PISGAH FOREST, NC. SN 77-909,026. FILED P.R. 1-11-2010; AM. S.R. 2-8-2011.

# ADVANCED AMERICAN POLYMERS

THE MARK CONSISTS OF STANDARD CHARACTERS WITHOUT CLAIM TO ANY PARTICULAR FONT, STYLE, SIZE, OR COLOR.

NO CLAIM IS MADE TO THE EXCLUSIVE RIGHT TO USE "POLYMERS", APART FROM THE MARK AS SHOWN, FOR FLOOR COVERINGS (U.S. CLS. 19, 20, 37, 42 AND 50).

FIRST USE 2-8-2011; IN COMMERCE 2-8-2011.

**CLASS 29—MEATS AND PROCESSED FOODS**

3,942,385. SQUIRREL BRAND, L.P., MCKINNEY, TX. SN 85-010,498. FILED P.R. 4-9-2010; AM. S.R. 1-30-2011.

# HERBES DE PROVENCE PECANS

THE MARK CONSISTS OF STANDARD CHARACTERS WITHOUT CLAIM TO ANY PARTICULAR FONT, STYLE, SIZE, OR COLOR.

OWNER OF U.S. REG. NOS. 3,629,071 AND 3,720,377.

NO CLAIM IS MADE TO THE EXCLUSIVE RIGHT TO USE "PECANS", APART FROM THE MARK AS SHOWN.

FOR PREPARED PROCESSED NUTS, NAMELY, PECANS (U.S. CL. 46).

FIRST USE 5-1-2010; IN COMMERCE 6-20-2010.

**CLASS 30—STAPLE FOODS**

3,942,342. WHITEY'S ICE CREAM, INC., MOLINE, IL. SN 77-823,135. FILED P.R. 9-9-2009; AM. S.R. 12-3-2010.



THE COLOR(S) GREEN, TAN, AND BROWN IS/ARE CLAIMED AS A FEATURE OF THE MARK.

**CLASS 30—(Continued).**

THE MARK CONSISTS OF THE COLORS GREEN, TAN, AND BROWN AS APPLIED TO THE VISIBLE SURFACE OF THE GOODS SWIRLED TOGETHER TO CREATE A CAMOUFLAGE EFFECT. THE MATTER SHOWN IN THE THREE-DIMENSIONAL DRAWING BY DOTTED LINES IS NOT PART OF THE MARK AND NO CLAIM IS MADE TO IT; IT SERVES ONLY TO SHOW THE POSITION OF THE MARK.

FOR ICE CREAM (U.S. CL. 46).  
FIRST USE 8-3-2009; IN COMMERCE 8-3-2009.

**CLASS 31—NATURAL AGRICULTURAL PRODUCTS**

3,942,380. GREEN TILLAGE LLC, HOLTWOOD, PA. SN 85-004,474. FILED P.R. 4-1-2010; AM. S.R. 2-1-2011.

**Cover Crop Solutions**

THE MARK CONSISTS OF STANDARD CHARACTERS WITHOUT CLAIM TO ANY PARTICULAR FONT, STYLE, SIZE, OR COLOR.

FOR AGRICULTURAL SEEDS; CROP SEEDS; GRASS SEED; PLANT SEEDS; RYE SEED; SEEDS FOR AGRICULTURAL PURPOSES; SOWING SEEDS; UNPROCESSED SEEDS FOR AGRICULTURAL USE (U.S. CLS. 1 AND 46).

FIRST USE 3-16-2010; IN COMMERCE 3-25-2010.

**CLASS 33—WINES AND SPIRITS**

3,942,334. ES/EX CORPORATION, SOUTH SAN FRANCISCO, CA. SN 77-646,971. FILED P.R. 1-9-2009; AM. S.R. 3-1-2010.

**PREMIUM VINTAGE CELLARS**

THE MARK CONSISTS OF STANDARD CHARACTERS WITHOUT CLAIM TO ANY PARTICULAR FONT, STYLE, SIZE, OR COLOR.

FOR WINE (U.S. CLS. 47 AND 49).  
FIRST USE 2-23-2010; IN COMMERCE 2-23-2010.

**CLASS 33—(Continued).**

3,942,354. DENNIS MURPHY, WALLA WALLA, WA. SN 77-873,317. FILED P.R. 11-16-2009; AM. S.R. 1-26-2011.

**Caprio Cellars**

THE MARK CONSISTS OF STANDARD CHARACTERS WITHOUT CLAIM TO ANY PARTICULAR FONT, STYLE, SIZE, OR COLOR.

NO CLAIM IS MADE TO THE EXCLUSIVE RIGHT TO USE "CELLARS", APART FROM THE MARK AS SHOWN. FOR WINES (U.S. CLS. 47 AND 49).

FIRST USE 7-3-2009; IN COMMERCE 7-3-2009.

3,942,393. TEQUILERA MILAGRO, S.A. DE C.V., COL. DESARROLLO SANTAFAE, MEXICO. SN 85-017,923. FILED P.R. 4-20-2010; AM. S.R. 2-3-2011.

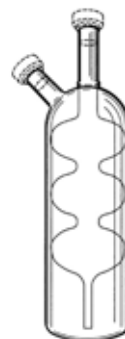

OWNER OF U.S. REG. NO. 3,593,910.

THE MARK CONSISTS OF A CONFIGURATION FOR THE CONTAINER FOR THE GOODS COMPRISING A BOTTLE FOR DISTILLED SPIRITS WITH A SIDE SPOUT CONNECTED TO THE INTERIOR CONTAINER OF THE BOTTLE AND A SEPARATE INNER BOTTLE CONSISTING OF A TUBE CONNECTED TO THE BOTTOM OF THE BOTTLE LINKED TO THREE OVAL SHAPED CONTAINERS FOLLOWED BY A LONG SPOUT TO THE TOP OF THE BOTTLE. THE TWO BOTTLE CAPS OR CORKS SHOWN IN DOTTED LINES ARE NOT CLAIMED AS A FEATURE OF THE MARK.

FOR DISTILLED SPIRITS (U.S. CLS. 47 AND 49).  
FIRST USE 10-30-1998; IN COMMERCE 10-30-1998.

**SERVICE MARKS****CLASS 35—ADVERTISING AND BUSINESS**



**CLASS 35—(Continued).**

3,942,345. GLOBAL PLASTICS, LP, SAN DIEGO, CA. SN 77-845,936. FILED P.R. 10-9-2009; AM. S.R. 2-14-2011.

**THE GREEN PLASTICS COMPANY**

THE MARK CONSISTS OF STANDARD CHARACTERS WITHOUT CLAIM TO ANY PARTICULAR FONT, STYLE, SIZE, OR COLOR.

NO CLAIM IS MADE TO THE EXCLUSIVE RIGHT TO USE "COMPANY", APART FROM THE MARK AS SHOWN.

FOR PROCUREMENT, NAMELY, PURCHASING ENVIRONMENTALLY FRIENDLY POLYETHYLENE RESINS, POLYPROPYLENE RESINS AND POLYSTYRENE RESINS FOR OTHERS; DISTRIBUTORSHIP SERVICES IN THE FIELD OF ENVIRONMENTALLY FRIENDLY POLYETHYLENE RESINS, POLYPROPYLENE RESINS AND POLYSTYRENE RESINS (U.S. CLS. 100, 101 AND 102).

FIRST USE 5-30-2007; IN COMMERCE 8-31-2008.

3,942,368. TIEGE HANLEY LLC, DBA PURCHASE POINT DESIGN, CHICAGO, IL. SN 77-940,638. FILED P.R. 2-20-2010; AM. S.R. 11-23-2010.

**Purchase Point Design**

THE MARK CONSISTS OF STANDARD CHARACTERS WITHOUT CLAIM TO ANY PARTICULAR FONT, STYLE, SIZE, OR COLOR.

NO CLAIM IS MADE TO THE EXCLUSIVE RIGHT TO USE "DESIGN", APART FROM THE MARK AS SHOWN.

FOR CREATIVE MARKETING DESIGN AND RESEARCH SERVICES FOR MANUFACTURERS, AGENTS, RETAILERS, AND END USERS IN THE POINT OF PURCHASE INDUSTRY (U.S. CLS. 100, 101 AND 102).

FIRST USE 8-27-2009; IN COMMERCE 11-5-2009.

3,942,381. THE PINE STRAW STORE LLC, AUGUSTA, GA. SN 85-005,096. FILED P.R. 4-2-2010; AM. S.R. 1-12-2011.

**1-800-PINESTRAW**

THE MARK CONSISTS OF STANDARD CHARACTERS WITHOUT CLAIM TO ANY PARTICULAR FONT, STYLE, SIZE, OR COLOR.

OWNER OF U.S. REG. NOS. 3,226,200, 3,574,324, AND OTHERS.

**CLASS 35—(Continued).**

NO CLAIM IS MADE TO THE EXCLUSIVE RIGHT TO USE "PINE STRAW", APART FROM THE MARK AS SHOWN.

FOR RETAIL PINE NEEDLE STORE SERVICES (U.S. CLS. 100, 101 AND 102).

FIRST USE 1-1-2009; IN COMMERCE 1-1-2009.

3,942,384. PROFESSIONAL BEAUTY ASSOCIATION, SCOTTSDALE, AZ. SN 85-009,799. FILED P.R. 4-8-2010; AM. S.R. 1-14-2011.

**MIDWEST  
international  
salon and spa  
expo**

NO CLAIM IS MADE TO THE EXCLUSIVE RIGHT TO USE "EXPO", APART FROM THE MARK AS SHOWN.

THE MARK CONSISTS OF A STYLIZED DEPICTION OF THE TERM "MIDWEST INTERNATIONAL SALON AND SPA EXPO".

FOR ORGANIZING, PROMOTING AND CONDUCTING TRADE SHOWS IN THE FIELD OF PROFESSIONAL BEAUTY CARE, SALON AND SPA INDUSTRIES (U.S. CLS. 100, 101 AND 102).

FIRST USE 3-30-2010; IN COMMERCE 3-30-2010.

3,942,404. ADVANCED PRESENTATION PRODUCTS INC., MISSISSAUGA, ONTARIO, CANADA. SN 85-036,906. FILED P.R. 5-12-2010; AM. S.R. 2-17-2011.

**DOCUMENT CAMERA EXPERTS**

THE MARK CONSISTS OF STANDARD CHARACTERS WITHOUT CLAIM TO ANY PARTICULAR FONT, STYLE, SIZE, OR COLOR.

PRIORITY CLAIMED UNDER SEC. 44(D) ON CANADA APPLICATION NO. 1459529, FILED 11-18-2009, REG. NO. TMA778,099, DATED 9-24-2010, EXPIRES 9-24-2025.

NO CLAIM IS MADE TO THE EXCLUSIVE RIGHT TO USE "DOCUMENT CAMERA", APART FROM THE MARK AS SHOWN.

FOR ONLINE RETAIL STORE SERVICES FEATURING DOCUMENT CAMERAS, DIGITAL PRESENTERS AND VISUALIZERS AND ACCESSORIES THEREFOR (U.S. CLS. 100, 101 AND 102).

FIRST USE 11-28-2008; IN COMMERCE 11-28-2008.

**CLASS 35—(Continued).**

3,942,408. COMMUNITYAMERICA CREDIT UNION, LEXINGTON, KS. SN 85-041,430. FILED 5-18-2010.

## WOMEN'S ASSOCIATION OF CREDIT UNION LEADERS

THE MARK CONSISTS OF STANDARD CHARACTERS WITHOUT CLAIM TO ANY PARTICULAR FONT, STYLE, SIZE, OR COLOR.

NO CLAIM IS MADE TO THE EXCLUSIVE RIGHT TO USE "ASSOCIATION", APART FROM THE MARK AS SHOWN.

FOR ASSOCIATION SERVICES, NAMELY, PROMOTING THE INTERESTS OF FEMALE CREDIT UNION LEADERS (U.S. CLS. 100, 101 AND 102).

FIRST USE 5-17-2010; IN COMMERCE 5-17-2010.

---

3,942,409. THE KNOT, INC., NEW YORK, NY. SN 85-046,458. FILED P.R. 5-24-2010; AM. S.R. 2-14-2011.

## LINK & SYNC

THE MARK CONSISTS OF STANDARD CHARACTERS WITHOUT CLAIM TO ANY PARTICULAR FONT, STYLE, SIZE, OR COLOR.

FOR PROVIDING AN ONLINE GIFT REGISTRY SERVICE (U.S. CLS. 100, 101 AND 102).

FIRST USE 4-30-2010; IN COMMERCE 4-30-2010.

---

3,942,413. THE GEM GROUP, INC., LAWRENCE, MA. SN 85-061,203. FILED P.R. 6-11-2010; AM. S.R. 3-1-2011.

## STYLISH & AFFORDABLE

THE MARK CONSISTS OF STANDARD CHARACTERS WITHOUT CLAIM TO ANY PARTICULAR FONT, STYLE, SIZE, OR COLOR.

FOR CATALOG ORDERING SERVICES FEATURING BAGS, CASES AND BUSINESS ACCESSORIES IMPORTED TO THE ORDER AND SPECIFICATION OF OTHERS (U.S. CLS. 100, 101 AND 102).

FIRST USE 7-1-2009; IN COMMERCE 7-1-2009.

**CLASS 35—(Continued).**

3,942,430. BRAND.NET, INC., SAN MATEO, CA. SN 85-095,241. FILED P.R. 7-28-2010; AM. S.R. 1-26-2011.

## MEDIA FUTURES PLATFORM

THE MARK CONSISTS OF STANDARD CHARACTERS WITHOUT CLAIM TO ANY PARTICULAR FONT, STYLE, SIZE, OR COLOR.

FOR ADVERTISING AND PROMOTION SERVICES AND RELATED CONSULTING; ADVERTISING SERVICES, NAMELY, PROMOTING AND MARKETING THE GOODS AND SERVICES OF OTHERS THROUGH ALL PUBLIC COMMUNICATION MEANS; ADVERTISING BY TRANSMISSION OF ON-LINE PUBLICITY FOR THIRD PARTIES THROUGH ELECTRONIC COMMUNICATIONS NETWORKS; PREPARATION AND REALIZATION OF MEDIA AND ADVERTISING PLANS AND CONCEPTS; RENTAL OF ADVERTISING SPACE ON WEB SITES; ADVERTISING CONSULTING SERVICES, NAMELY, PROVIDING ADVERTISING PRICING AND INVENTORY INFORMATION; ADVERTISING CONSULTING SERVICES, NAMELY, PLACING ONLINE ADVERTISEMENTS FOR OTHERS (U.S. CLS. 100, 101 AND 102).

FIRST USE 1-0-2010; IN COMMERCE 1-0-2010.

---

3,942,435. GEOGRAPHIC SOLUTIONS, INC., PALM HARBOR, FL. SN 85-113,153. FILED P.R. 8-23-2010; AM. S.R. 1-6-2011.

## VIRTUAL LMI

THE MARK CONSISTS OF STANDARD CHARACTERS WITHOUT CLAIM TO ANY PARTICULAR FONT, STYLE, SIZE, OR COLOR.

NO CLAIM IS MADE TO THE EXCLUSIVE RIGHT TO USE "LMI", APART FROM THE MARK AS SHOWN.

FOR PROVIDING ON-LINE LABOR MARKET AND EMPLOYMENT INFORMATION IN THE FIELDS OF LABOR EXCHANGE, DEMOGRAPHIC DATA, LABOR MARKET INFORMATION AND LABOR MARKET ANALYSIS (U.S. CLS. 100, 101 AND 102).

FIRST USE 12-31-2003; IN COMMERCE 12-31-2003.

**CLASS 35—(Continued).**

3,942,436. THAYER, CHERYL, CONCORD, CA. SN 85-114,308. FILED P.R. 8-24-2010; AM. S.R. 2-1-2011.

**CHAMPAGNE TUESDAY**

THE MARK CONSISTS OF STANDARD CHARACTERS WITHOUT CLAIM TO ANY PARTICULAR FONT, STYLE, SIZE, OR COLOR.

FOR BUSINESS NETWORKING, NAMELY, PLANNING, ARRANGING, AND CONDUCTING EVENTS FOR BUSINESS PURPOSES AND PROMOTION OF THE GOODS AND SERVICES OF OTHERS (U.S. CLS. 100, 101 AND 102).

FIRST USE 2-14-2006; IN COMMERCE 10-10-2008.

---

3,942,437. CAREER COLLEGE ASSOCIATION, WASHINGTON, DC. SN 85-116,849. FILED P.R. 8-26-2010; AM. S.R. 2-22-2011.

**ASSOCIATION OF PRIVATE  
SECTOR COLLEGES AND  
UNIVERSITIES**

THE MARK CONSISTS OF STANDARD CHARACTERS WITHOUT CLAIM TO ANY PARTICULAR FONT, STYLE, SIZE, OR COLOR.

NO CLAIM IS MADE TO THE EXCLUSIVE RIGHT TO USE "ASSOCIATION", APART FROM THE MARK AS SHOWN.

FOR ASSOCIATION SERVICES, NAMELY, PROMOTING THE INTERESTS OF PRIVATE SECTOR, POSTSECONDARY SCHOOLS, INSTITUTES, COLLEGES, AND UNIVERSITIES (U.S. CLS. 100, 101 AND 102).

FIRST USE 9-22-2010; IN COMMERCE 9-22-2010.

---

3,942,438. TRANSCONTINENTAL EVENTS, LLC, SEATTLE, WA. SN 85-118,913. FILED P.R. 8-30-2010; AM. S.R. 2-2-2011.

**ESPONSOR**

THE MARK CONSISTS OF STANDARD CHARACTERS WITHOUT CLAIM TO ANY PARTICULAR FONT, STYLE, SIZE, OR COLOR.

FOR BUSINESS STRATEGY DEVELOPMENT SERVICES; ONLINE AUCTIONS; MARKETING AND BRANDING SERVICES, NAMELY, PROVIDING CUSTOMIZED COMMUNICATION PROGRAMS TO OBTAIN CONSUMER INSIGHTS AND DEVELOP BRANDING STRATEGIES; ADVERTISING, MARKETING AND PROMOTION SERVICES (U.S. CLS. 100, 101 AND 102).

FIRST USE 2-0-2003; IN COMMERCE 2-0-2003.

**CLASS 35—(Continued).**

3,942,445. HOMEGOODS, INC., FRAMINGHAM, MA. SN 85-133,645. FILED P.R. 9-20-2010; AM. S.R. 2-1-2011.

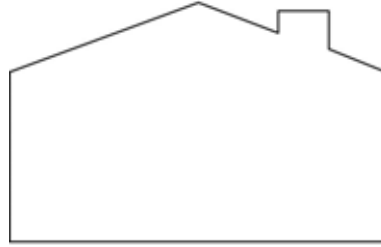

THE MARK CONSISTS OF THE SHAPE OF A HOUSE. FOR RETAIL DEPARTMENT STORE SERVICES (U.S. CLS. 100, 101 AND 102).

FIRST USE 8-15-2010; IN COMMERCE 8-15-2010.

---

3,942,447. TECHNOLOGY AND ENTREPRENEURSHIP CENTER OF HOUSTON, INC., DBA HOUSTON TECHNOLOGY CENTER, HOUSTON, TX. SN 85-140,861. FILED P.R. 9-29-2010; AM. S.R. 1-25-2011.

**Gulf Coast Innovation  
Conference and Showcase**

THE MARK CONSISTS OF STANDARD CHARACTERS WITHOUT CLAIM TO ANY PARTICULAR FONT, STYLE, SIZE, OR COLOR.

NO CLAIM IS MADE TO THE EXCLUSIVE RIGHT TO USE "CONFERENCE AND SHOWCASE", APART FROM THE MARK AS SHOWN.

FOR ORGANIZING AND CONDUCTING PERIODIC PROFESSIONAL BUSINESS MEETINGS FOR OTHERS TO DISPLAY TECHNOLOGIES AND FOR OTHERS TO DISCUSS TECHNOLOGY RESEARCH, INNOVATION AND COMMERCIALIZATION ISSUES AND FOR THE PURPOSES OF BUSINESS NETWORKING (U.S. CLS. 100, 101 AND 102).

FIRST USE 10-21-2009; IN COMMERCE 10-21-2009.

**CLASS 35—(Continued).**

3,942,452. AHOLD LICENSING SARL, GENEVA, SWITZERLAND. SN 85-148,539. FILED 10-8-2010.



THE COLOR(S) YELLOW, WHITE AND GREEN IS/ARE CLAIMED AS A FEATURE OF THE MARK.

THE MARK CONSISTS OF THE WORD "REAL" APPEARS IN GREEN ON A YELLOW RECTANGLE WITH ROUNDED CORNERS ABOVE THE WORD "deal!" IN WHITE, FOLLOWED BY A YELLOW EXCLAMATION POINT, ALL OUTLINED IN GREEN.

FOR RETAIL GROCERY STORES (U.S. CLS. 100, 101 AND 102).

FIRST USE 8-0-2009; IN COMMERCE 8-0-2009.

3,942,454. NORTHWESTERN CORPORATION, DBA NORTHWESTERN ENERGY, SIOUX FALLS, SD. SN 85-150,347. FILED P.R. 10-12-2010; AM. S.R. 2-1-2011.

**MONTANA RENEWABLE  
COLLECTOR SYSTEM**

THE MARK CONSISTS OF STANDARD CHARACTERS WITHOUT CLAIM TO ANY PARTICULAR FONT, STYLE, SIZE, OR COLOR.

FOR PROMOTING PUBLIC AWARENESS OF THE NEED FOR RENEWABLE ENERGY SOURCES AND THE COLLECTION AND TRANSMISSION INFRASTRUCTURE NEEDED TO CAPTURE ELECTRICITY GENERATION FROM WIND POWER; PROMOTING PUBLIC AWARENESS OF RENEWABLE ENERGY SOURCES AND THE COLLECTION AND TRANSMISSION INFRASTRUCTURE NEEDED TO CAPTURE ELECTRICITY GENERATION FROM WIND POWER (U.S. CLS. 100, 101 AND 102).

FIRST USE 3-1-2010; IN COMMERCE 3-1-2010.

**CLASS 35—(Continued).**

3,942,462. D. PAGLIA & SON, INC., MOUNTAINSIDE, NJ. SN 85-162,647. FILED P.R. 10-27-2010; AM. S.R. 2-24-2011.

**ULTIMATE EQUINE JEWELRY**

THE MARK CONSISTS OF STANDARD CHARACTERS WITHOUT CLAIM TO ANY PARTICULAR FONT, STYLE, SIZE, OR COLOR.

NO CLAIM IS MADE TO THE EXCLUSIVE RIGHT TO USE "EQUINE JEWELRY", APART FROM THE MARK AS SHOWN.

FOR ONLINE RETAIL STORE SERVICES FEATURING JEWELRY (U.S. CLS. 100, 101 AND 102).

FIRST USE 3-9-2009; IN COMMERCE 3-9-2009.

3,942,468. AMERICAN ASSOCIATION OF VASCULAR SURGERY AND PHLEBOLOGY, INC., GRAND JUNCTION, CO. SN 85-175,320. FILED 11-12-2010.

**American Association of  
Vascular Surgery &  
Phlebology**

THE MARK CONSISTS OF STANDARD CHARACTERS WITHOUT CLAIM TO ANY PARTICULAR FONT, STYLE, SIZE, OR COLOR.

FOR ASSOCIATION SERVICES, NAMELY, PROMOTING THE INTERESTS OF PHYSICIANS ENGAGED IN VASCULAR SURGERY AND PHLEBOLOGY (U.S. CLS. 100, 101 AND 102).

FIRST USE 7-1-2006; IN COMMERCE 7-1-2006.

**CLASS 36—INSURANCE AND FINANCIAL**

3,942,377. UMOVEFREE, FLOWER MOUND, TX. SN 78-227,853. FILED P.R. 3-20-2003; AM. S.R. 3-2-2004.

**UMOVEFREE**

FOR APARTMENT LOCATING SERVICES FOR OTHERS (U.S. CLS. 100, 101 AND 102).

FIRST USE 9-7-2002; IN COMMERCE 9-7-2002.

**CLASS 36—(Continued).**

3,942,379. BANK OF SOUTHERN CALIFORNIA, N.A., SAN DIEGO, CA. SN 85-001,752. FILED P.R. 3-30-2010; AM. S.R. 12-15-2010.

BANK OF SOUTHERN CALIFORNIA

THE MARK CONSISTS OF STANDARD CHARACTERS WITHOUT CLAIM TO ANY PARTICULAR FONT, STYLE, SIZE, OR COLOR.

NO CLAIM IS MADE TO THE EXCLUSIVE RIGHT TO USE "BANK", APART FROM THE MARK AS SHOWN.

FOR BANKING SERVICES (U.S. CLS. 100, 101 AND 102).

FIRST USE 6-28-2010; IN COMMERCE 6-28-2010.

3,942,383. REAL PROPERTY MANAGEMENT, INC., LAYTON, UT. SN 85-008,576. FILED P.R. 4-7-2010; AM. S.R. 2-24-2011.

The Nation's Local  
Property Manager

THE MARK CONSISTS OF STANDARD CHARACTERS WITHOUT CLAIM TO ANY PARTICULAR FONT, STYLE, SIZE, OR COLOR.

NO CLAIM IS MADE TO THE EXCLUSIVE RIGHT TO USE "PROPERTY MANAGER", APART FROM THE MARK AS SHOWN.

FOR REAL ESTATE MANAGEMENT SERVICES (U.S. CLS. 100, 101 AND 102).

FIRST USE 2-1-2010; IN COMMERCE 2-17-2010.

3,942,428. AUTOMOTIVE FINANCE CORPORATION, INDIANAPOLIS, IN. SN 85-082,830. FILED P.R. 7-12-2010; AM. S.R. 2-2-2011.

7-14-21

THE MARK CONSISTS OF STANDARD CHARACTERS WITHOUT CLAIM TO ANY PARTICULAR FONT, STYLE, SIZE, OR COLOR.

FOR FINANCIAL SERVICES, NAMELY, AUTOMOTIVE DEALER FLOORPLAN FINANCING (U.S. CLS. 100, 101 AND 102).

FIRST USE 10-9-2003; IN COMMERCE 10-9-2003.

**CLASS 36—(Continued).**

3,942,439. LAND4LESS.US, LLC, QUEEN CREEK, AZ. SN 85-123,573. FILED P.R. 9-6-2010; AM. S.R. 12-16-2010.

Land4Less

THE MARK CONSISTS OF STANDARD CHARACTERS WITHOUT CLAIM TO ANY PARTICULAR FONT, STYLE, SIZE, OR COLOR.

FOR LAND ACQUISITION SERVICES (U.S. CLS. 100, 101 AND 102).

FIRST USE 0-0-2007; IN COMMERCE 0-0-2008.

3,942,442. GMAC INSURANCE MANAGEMENT CORPORATION, WINSTON-SALEM, NC. SN 85-129,285. FILED P.R. 9-14-2010; AM. S.R. 1-6-2011.

10 Minute

THE MARK CONSISTS OF STANDARD CHARACTERS WITHOUT CLAIM TO ANY PARTICULAR FONT, STYLE, SIZE, OR COLOR.

FOR INSURANCE UNDERWRITING IN THE FIELD OF PROPERTY AND CASUALTY INSURANCE, NAMELY, AUTOMOBILE INSURANCE (U.S. CLS. 100, 101 AND 102).

FIRST USE 10-8-2010; IN COMMERCE 10-8-2010.

3,942,456. BARRETT, BRAD, AKA ATLANTIC COAST CASUALTY, ORLANDO, FL. SN 85-153,082. FILED P.R. 10-14-2010; AM. S.R. 1-31-2011.

ATLANTIC COAST CASUALTY

THE MARK CONSISTS OF STANDARD CHARACTERS WITHOUT CLAIM TO ANY PARTICULAR FONT, STYLE, SIZE, OR COLOR.

NO CLAIM IS MADE TO THE EXCLUSIVE RIGHT TO USE "CASUALTY", APART FROM THE MARK AS SHOWN.

FOR APPRAISALS FOR INSURANCE CLAIMS OF PERSONAL PROPERTY; APPRAISALS FOR INSURANCE CLAIMS OF REAL ESTATE; INSURANCE ADMINISTRATION SERVICES, NAMELY, ASSISTING OTHERS WITH ADJUSTING INSURANCE CLAIMS; INSURANCE CONSULTANCY SERVICES, NAMELY, PROVIDING ADVICE IN THE FIELD OF PROPERTY AND CASUALTY INSURANCE; INSURANCE CONSULTATION (U.S. CLS. 100, 101 AND 102).

FIRST USE 3-2-2007; IN COMMERCE 3-2-2007.

**CLASS 36—(Continued).**

3,942,470. RANSTAD GROUP INC, EUGENE, OR. SN 85-180,455. FILED P.R. 11-18-2010; AM. S.R. 2-28-2011.

## Hybrid Real Estate

THE MARK CONSISTS OF STANDARD CHARACTERS WITHOUT CLAIM TO ANY PARTICULAR FONT, STYLE, SIZE, OR COLOR.

NO CLAIM IS MADE TO THE EXCLUSIVE RIGHT TO USE "REAL ESTATE", APART FROM THE MARK AS SHOWN.

FOR REAL ESTATE AGENCIES (U.S. CLS. 100, 101 AND 102).

FIRST USE 11-30-2007; IN COMMERCE 11-30-2007.

**CLASS 37—CONSTRUCTION AND REPAIR**

3,942,333. ALL AMERICAN CORPORATION, KENNEWICK, WA. SN 77-618,684. FILED P.R. 11-20-2008; AM. S.R. 7-27-2009.

## American Home Centers

THE MARK CONSISTS OF STANDARD CHARACTERS WITHOUT CLAIM TO ANY PARTICULAR FONT, STYLE, SIZE, OR COLOR.

FOR REAL ESTATE DEVELOPMENT (U.S. CLS. 100, 103 AND 106).

FIRST USE 1-1-2009; IN COMMERCE 3-1-2009.

3,942,339. GUTIERREZ, MARTIN JR., SAN ANTONIO, TX. SN 77-731,559. FILED P.R. 5-7-2009; AM. S.R. 2-18-2011.

BRINGYOUROWNPARTS.COM

THE MARK CONSISTS OF STANDARD CHARACTERS WITHOUT CLAIM TO ANY PARTICULAR FONT, STYLE, SIZE, OR COLOR.

FOR ON-LINE COMPUTER SERVICES, NAMELY, PROVIDING AN ONLINE DATABASE IN THE FIELD OF AUTOMOTIVE REPAIR SERVICES (U.S. CLS. 100, 103 AND 106).

FIRST USE 1-14-2011; IN COMMERCE 1-14-2011.

**CLASS 37—(Continued).**

3,942,422. SOCKEYE CONSTRUCTION CORP., DBA SOCKEYE HOMES, AUBURN, WA. SN 85-061,976. FILED P.R. 6-14-2010; AM. S.R. 1-31-2011.

## AWARD WINNING QUALITY AT A LOWER PRICE

THE MARK CONSISTS OF STANDARD CHARACTERS WITHOUT CLAIM TO ANY PARTICULAR FONT, STYLE, SIZE, OR COLOR.

FOR CUSTOM CONSTRUCTION OF HOMES; REMODELING OF HOMES (U.S. CLS. 100, 103 AND 106).

FIRST USE 2-0-2009; IN COMMERCE 2-0-2009.

3,942,459. FORMAN, FRANK, FORT LAUDERDALE, FL. SN 85-156,590. FILED P.R. 10-19-2010; AM. S.R. 2-1-2011.

## Sol-R-Wash

THE MARK CONSISTS OF STANDARD CHARACTERS WITHOUT CLAIM TO ANY PARTICULAR FONT, STYLE, SIZE, OR COLOR.

FOR CLEANING AND MAINTENANCE OF SOLAR PANELS, SOLAR TUBES, SOLAR TROUGHS AND SOLAR MIRRORS (U.S. CLS. 100, 103 AND 106).

FIRST USE 9-1-2010; IN COMMERCE 9-1-2010.

**CLASS 40—MATERIAL TREATMENT**

3,942,399. E.ON CLIMATE & RENEWABLES NORTH AMERICA, LLC, AUSTIN, TX. SN 85-020,843. FILED P.R. 4-22-2010; AM. S.R. 1-31-2011.

## Panther Creek Wind Farm

THE MARK CONSISTS OF STANDARD CHARACTERS WITHOUT CLAIM TO ANY PARTICULAR FONT, STYLE, SIZE, OR COLOR.

NO CLAIM IS MADE TO THE EXCLUSIVE RIGHT TO USE "WIND FARM", APART FROM THE MARK AS SHOWN.

FOR PRODUCTION OF WIND ENERGY (U.S. CLS. 100, 103 AND 106).

FIRST USE 1-23-2007; IN COMMERCE 9-15-2008.

**CLASS 40—(Continued).**

3,942,414. E.ON CLIMATE & RENEWABLES NORTH AMERICA, LLC, AUSTIN, TX. SN 85-061,754. FILED P.R. 6-14-2010; AM. S.R. 1-31-2011.

**Papalote Creek Wind Farm**

THE MARK CONSISTS OF STANDARD CHARACTERS WITHOUT CLAIM TO ANY PARTICULAR FONT, STYLE, SIZE, OR COLOR.

NO CLAIM IS MADE TO THE EXCLUSIVE RIGHT TO USE "WIND FARM", APART FROM THE MARK AS SHOWN.

THE ENGLISH TRANSLATION OF THE WORD "PAPALOTE" IN THE MARK IS "KITE".

FOR PRODUCTION OF WIND ENERGY (U.S. CLS. 100, 103 AND 106).

FIRST USE 4-23-2008; IN COMMERCE 10-1-2009.

---

3,942,415. E.ON CLIMATE & RENEWABLES NORTH AMERICA, LLC, AUSTIN, TX. SN 85-061,803. FILED P.R. 6-14-2010; AM. S.R. 1-31-2011.

**Forest Creek Wind Farm**

THE MARK CONSISTS OF STANDARD CHARACTERS WITHOUT CLAIM TO ANY PARTICULAR FONT, STYLE, SIZE, OR COLOR.

NO CLAIM IS MADE TO THE EXCLUSIVE RIGHT TO USE "WIND FARM", APART FROM THE MARK AS SHOWN.

FOR PRODUCTION OF WIND ENERGY (U.S. CLS. 100, 103 AND 106).

FIRST USE 11-4-2005; IN COMMERCE 12-20-2006.

---

3,942,416. E.ON CLIMATE & RENEWABLES NORTH AMERICA, LLC, AUSTIN, TX. SN 85-061,814. FILED P.R. 6-14-2010; AM. S.R. 1-31-2011.

**Sand Bluff Wind Farm**

THE MARK CONSISTS OF STANDARD CHARACTERS WITHOUT CLAIM TO ANY PARTICULAR FONT, STYLE, SIZE, OR COLOR.

NO CLAIM IS MADE TO THE EXCLUSIVE RIGHT TO USE "WIND FARM", APART FROM THE MARK AS SHOWN.

FOR PRODUCTION OF WIND ENERGY (U.S. CLS. 100, 103 AND 106).

FIRST USE 1-19-2006; IN COMMERCE 1-28-2008.

**CLASS 40—(Continued).**

3,942,417. E.ON CLIMATE & RENEWABLES NORTH AMERICA, LLC, AUSTIN, TX. SN 85-061,832. FILED P.R. 6-14-2010; AM. S.R. 1-31-2011.

**Munnsville Wind Farm**

THE MARK CONSISTS OF STANDARD CHARACTERS WITHOUT CLAIM TO ANY PARTICULAR FONT, STYLE, SIZE, OR COLOR.

NO CLAIM IS MADE TO THE EXCLUSIVE RIGHT TO USE "WIND FARM", APART FROM THE MARK AS SHOWN.

FOR PRODUCTION OF WIND ENERGY (U.S. CLS. 100, 103 AND 106).

FIRST USE 12-15-2003; IN COMMERCE 9-27-2007.

---

3,942,418. E.ON CLIMATE & RENEWABLES NORTH AMERICA, LLC, AUSTIN, TX. SN 85-061,856. FILED P.R. 6-14-2010; AM. S.R. 1-31-2011.

**Roscoe Wind Farm**

THE MARK CONSISTS OF STANDARD CHARACTERS WITHOUT CLAIM TO ANY PARTICULAR FONT, STYLE, SIZE, OR COLOR.

NO CLAIM IS MADE TO THE EXCLUSIVE RIGHT TO USE "WIND FARM", APART FROM THE MARK AS SHOWN.

FOR PRODUCTION OF WIND ENERGY (U.S. CLS. 100, 103 AND 106).

FIRST USE 7-18-2006; IN COMMERCE 2-20-2008.

---

3,942,419. E.ON CLIMATE & RENEWABLES NORTH AMERICA, LLC, AUSTIN, TX. SN 85-061,891. FILED P.R. 6-14-2010; AM. S.R. 1-31-2011.

**Pyron Wind Farm**

THE MARK CONSISTS OF STANDARD CHARACTERS WITHOUT CLAIM TO ANY PARTICULAR FONT, STYLE, SIZE, OR COLOR.

NO CLAIM IS MADE TO THE EXCLUSIVE RIGHT TO USE "WIND FARM", APART FROM THE MARK AS SHOWN.

FOR PRODUCTION OF WIND ENERGY (U.S. CLS. 100, 103 AND 106).

FIRST USE 12-13-2006; IN COMMERCE 12-23-2008.

**CLASS 40—(Continued).**

3,942,420. E.ON CLIMATE & RENEWABLES NORTH AMERICA, LLC, AUSTIN, TX. SN 85-061,902. FILED P.R. 6-14-2010; AM. S.R. 1-31-2011.

## Inadale Wind Farm

THE MARK CONSISTS OF STANDARD CHARACTERS WITHOUT CLAIM TO ANY PARTICULAR FONT, STYLE, SIZE, OR COLOR.

NO CLAIM IS MADE TO THE EXCLUSIVE RIGHT TO USE "WIND FARM", APART FROM THE MARK AS SHOWN.

FOR PRODUCTION OF WIND ENERGY (U.S. CLS. 100, 103 AND 106).

FIRST USE 5-16-2007; IN COMMERCE 12-18-2008.

---

3,942,421. E.ON CLIMATE & RENEWABLES NORTH AMERICA, LLC, AUSTIN, TX. SN 85-061,911. FILED P.R. 6-14-2010; AM. S.R. 1-31-2011.

## Stony Creek Wind Farm

THE MARK CONSISTS OF STANDARD CHARACTERS WITHOUT CLAIM TO ANY PARTICULAR FONT, STYLE, SIZE, OR COLOR.

NO CLAIM IS MADE TO THE EXCLUSIVE RIGHT TO USE "WIND FARM", APART FROM THE MARK AS SHOWN.

FOR PRODUCTION OF WIND ENERGY (U.S. CLS. 100, 103 AND 106).

FIRST USE 5-16-2007; IN COMMERCE 10-23-2009.

---

### CLASS 41—EDUCATION AND ENTERTAINMENT

3,942,328. FORESMAN, GUY STUART, SANTA ANA, CA. SN 76-697,871. FILED P.R. 6-11-2009; AM. S.R. 1-14-2011.

## DIGITAL MANIPULATIVES

THE MARK CONSISTS OF STANDARD CHARACTERS WITHOUT CLAIM TO ANY PARTICULAR FONT, STYLE, SIZE, OR COLOR.

FOR EDUCATION SERVICES, NAMELY, PROVIDING ON-LINE LESSONS IN THE FIELDS OF ELEMENTARY AND SECONDARY EDUCATION (U.S. CLS. 100, 101 AND 107).

FIRST USE 4-1-2009; IN COMMERCE 4-1-2009.

**CLASS 41—(Continued).**

3,942,361. ENGAGE HEALTHCARE COMMUNICATIONS, LLC, MONROE TWP., NJ. SN 77-909,178. FILED P.R. 1-11-2010; AM. S.R. 2-2-2011.

## VALUE-BASED CANCER CARE

THE MARK CONSISTS OF STANDARD CHARACTERS WITHOUT CLAIM TO ANY PARTICULAR FONT, STYLE, SIZE, OR COLOR.

NO CLAIM IS MADE TO THE EXCLUSIVE RIGHT TO USE "CANCER CARE", APART FROM THE MARK AS SHOWN.

FOR ONLINE EDUCATIONAL SERVICES, NAMELY, PROVIDING CONTINUING PROFESSIONAL EDUCATION COURSES AND EXAMINATIONS IN THE FIELDS OF ONCOLOGY AND CANCER VIA A GLOBAL COMPUTER INFORMATION NETWORK; PROVIDING ONLINE INFORMATION ABOUT CONTINUING EDUCATION IN THE FIELDS OF ONCOLOGY AND CANCER (U.S. CLS. 100, 101 AND 107).

FIRST USE 1-2-2010; IN COMMERCE 10-1-2010.

---

3,942,370. BLUEJAY HANKINS, TONASKET, WA. SN 77-951,245. FILED P.R. 3-5-2010; AM. S.R. 2-28-2011.

## Okanogan Highlands Productions

THE MARK CONSISTS OF STANDARD CHARACTERS WITHOUT CLAIM TO ANY PARTICULAR FONT, STYLE, SIZE, OR COLOR.

NO CLAIM IS MADE TO THE EXCLUSIVE RIGHT TO USE "PRODUCTIONS", APART FROM THE MARK AS SHOWN.

FOR ENTERTAINMENT, NAMELY, LIVE MUSIC CONCERTS (U.S. CLS. 100, 101 AND 107).

FIRST USE 9-28-2009; IN COMMERCE 10-7-2009.



**CLASS 41—(Continued).**

3,942,374. ENDGAME ENTERPRISES, LLC, WESTMINSTER, CO. SN 77-964,691. FILED 3-22-2010.



OWNER OF U.S. REG. NOS. 3,605,724 AND 3,644,482. THE COLOR(S) PURPLE IS/ARE CLAIMED AS A FEATURE OF THE MARK.

THE MARK CONSISTS OF PURPLE-COLORED STAMP-LIKE SCALLOPED EDGES PLACED ALONG THE OUTER EDGE OF GRAPHIC ELEMENTS ASSOCIATED WITH APPLICANT'S SERVICES.

FOR EDUCATIONAL AND ENTERTAINMENT SERVICES, NAMELY, A CONTINUING PROGRAM ABOUT ANIMAL AWARENESS, RELATIONSHIPS, HISTORY, LIFE, LITERATURE, PHILOSOPHY, POLITICS, PSYCHOLOGY, SCIENCE AND TECHNOLOGY, HUMOR, AND POLITICAL AND SOCIAL SATIRE, ACCESSIBLE BY SATELLITE AND COMPUTER NETWORKS; EDUCATIONAL SERVICES, NAMELY, PROVIDING AN ON-LINE WEBSITE FEATURING INFORMAL ONLINE PROGRAMS IN THE FIELDS OF ANIMAL AWARENESS, RELATIONSHIPS, HISTORY, LIFE, LITERATURE, PHILOSOPHY, POLITICS, PSYCHOLOGY, SCIENCE AND TECHNOLOGY, HUMOR, AND POLITICAL AND SOCIAL SATIRE; PROVIDING ON-LINE PUBLICATIONS IN THE NATURE OF COMIC STRIPS AND BLOGS IN THE FIELDS OF ANIMAL AWARENESS, RELATIONSHIPS, HISTORY, LIFE, LITERATURE, PHILOSOPHY, POLITICS, PSYCHOLOGY, SCIENCE AND TECHNOLOGY, HUMOR, AND POLITICAL AND SOCIAL SATIRE (U.S. CLS. 100, 101 AND 107).

FIRST USE 5-1-2008; IN COMMERCE 8-19-2008.

3,942,376. SERVICE COMPANY SOLUTIONS, LLC, BEDFORD, NH. SN 77-980,779. FILED P.R. 9-14-2009; AM. S.R. 1-11-2011.

### The Original Blue Book Major Appliance Job Rate Guide

THE MARK CONSISTS OF STANDARD CHARACTERS WITHOUT CLAIM TO ANY PARTICULAR FONT, STYLE, SIZE, OR COLOR.

NO CLAIM IS MADE TO THE EXCLUSIVE RIGHT TO USE "GUIDE", APART FROM THE MARK AS SHOWN.

FOR PUBLICATION OF BOOKS AND PROVIDING ON-LINE PUBLICATIONS IN THE NATURE OF AN E-BOOK, NAMELY, IN THE FIELD OF APPLIANCE REPAIR (U.S. CLS. 100, 101 AND 107).

FIRST USE 1-1-2010; IN COMMERCE 1-1-2010.

**CLASS 41—(Continued).**

3,942,396. PORTER, ROBERT, A, DBA MOXIE MEDIA, OVIEDO, FL. SN 85-018,852. FILED P.R. 4-20-2010; AM. S.R. 1-26-2011.

### THE SEX OFFENDER REGISTER

THE MARK CONSISTS OF STANDARD CHARACTERS WITHOUT CLAIM TO ANY PARTICULAR FONT, STYLE, SIZE, OR COLOR.

NO CLAIM IS MADE TO THE EXCLUSIVE RIGHT TO USE "REGISTER", APART FROM THE MARK AS SHOWN. FOR MAGAZINE PUBLISHING (U.S. CLS. 100, 101 AND 107).

FIRST USE 4-20-2010; IN COMMERCE 4-20-2010.

3,942,411. THE SERVICE DOG INSTITUTE OF SOUTH CAROLINA, SIMPSONVILLE, SC. SN 85-051,022. FILED P.R. 5-30-2010; AM. S.R. 1-30-2011.

### THE SERVICE DOG INSTITUTE

THE MARK CONSISTS OF STANDARD CHARACTERS WITHOUT CLAIM TO ANY PARTICULAR FONT, STYLE, SIZE, OR COLOR.

NO CLAIM IS MADE TO THE EXCLUSIVE RIGHT TO USE "INSTITUTE", APART FROM THE MARK AS SHOWN.

FOR ANIMAL TRAINING SERVICES, NAMELY, TRAINING SERVICE ANIMALS FOR USE BY PERSONS WITH SPECIAL NEEDS AND DISABILITIES; EDUCATIONAL SERVICES, NAMELY, DEVELOPING AND CONDUCTING EDUCATIONAL CLASSES, SEMINARS AND WORKSHOPS IN THE FIELD OF ANIMAL TRAINING AND SERVICE ANIMALS FOR PERSONS WITH SPECIAL NEEDS AND DISABILITIES, AND DISTRIBUTION OF PRINTED MATERIALS IN CONNECTION THEREWITH; PROVIDING INFORMATION IN THE FIELD OF ANIMAL TRAINING SERVICES FOR PERSONS WITH SPECIAL NEEDS AND DISABILITIES (U.S. CLS. 100, 101 AND 107).

FIRST USE 7-0-2010; IN COMMERCE 7-0-2010.

**CLASS 41—(Continued).**

3,942,423. STAPLES, LEXI, TOLEDO, OH. SN 85-075,964. FILED P.R. 7-1-2010; AM. S.R. 1-24-2011.

## Toledo Pride

THE MARK CONSISTS OF STANDARD CHARACTERS WITHOUT CLAIM TO ANY PARTICULAR FONT, STYLE, SIZE, OR COLOR.

FOR ENTERTAINMENT IN THE NATURE OF ORGANIZING AND CONDUCTING COMMUNITY FESTIVALS FEATURING LIVE MUSICAL PERFORMANCES WHICH FOSTER PRIDE IN A WIDE VARIETY OF SEXUAL ORIENTATIONS, NAMELY, LESBIAN, GAY, BISEXUAL AND TRANSGENDER IDENTITIES; ORGANIZING COMMUNITY FESTIVALS FEATURING PRIMARILY LIVE MUSICAL PERFORMANCES AND ALSO PROVIDING AWARENESS AND EDUCATION TO FOSTER PRIDE IN A WIDE VARIETY OF SEXUAL ORIENTATIONS (U.S. CLS. 100, 101 AND 107).

FIRST USE 5-1-2010; IN COMMERCE 5-1-2010.

3,942,434. MICHELLI, RICHARD J., OCEAN, NJ. SN 85-110,518. FILED P.R. 8-18-2010; AM. S.R. 2-1-2011.

## ITALIA LIVING

THE MARK CONSISTS OF STANDARD CHARACTERS WITHOUT CLAIM TO ANY PARTICULAR FONT, STYLE, SIZE, OR COLOR.

THE ENGLISH TRANSLATION OF "ITALIA" IN THE MARK IS "ITALY".

FOR PROVIDING ON-LINE MAGAZINES IN THE FIELD OF LUXURY ITALIAN LIVING AND LIFESTYLE (U.S. CLS. 100, 101 AND 107).

FIRST USE 3-0-2007; IN COMMERCE 3-0-2007.

3,942,446. KUHLSPORT LTD., CINCINNATI, OH. SN 85-137,909. FILED P.R. 9-24-2010; AM. S.R. 1-12-2011.

## KUHLSPORT

THE MARK CONSISTS OF STANDARD CHARACTERS WITHOUT CLAIM TO ANY PARTICULAR FONT, STYLE, SIZE, OR COLOR.

FOR ENTERTAINMENT SERVICES IN THE NATURE OF PARTICIPATING IN AUTOMOBILE RACES AND RELATED EXHIBITIONS (U.S. CLS. 100, 101 AND 107).

FIRST USE 2-0-2009; IN COMMERCE 2-0-2009.

**CLASS 41—(Continued).**

3,942,461. RACHEL ARAM, SAN FRANCISCO, CA. SN 85-160,707. FILED P.R. 10-25-2010; AM. S.R. 2-2-2011.

## The San Francisco Method

THE MARK CONSISTS OF STANDARD CHARACTERS WITHOUT CLAIM TO ANY PARTICULAR FONT, STYLE, SIZE, OR COLOR.

NO CLAIM IS MADE TO THE EXCLUSIVE RIGHT TO USE "METHOD", APART FROM THE MARK AS SHOWN.

FOR PHYSICAL FITNESS INSTRUCTION (U.S. CLS. 100, 101 AND 107).

FIRST USE 10-1-2010; IN COMMERCE 10-1-2010.

3,942,466. ROYAL WINE CORPORATION DBA HERZOG WINE CELLARS, BAYONNE, NJ. SN 85-171,596. FILED P.R. 11-8-2010; AM. S.R. 2-17-2011.

## INTERNATIONAL FOOD & WINE FESTIVAL

THE MARK CONSISTS OF STANDARD CHARACTERS WITHOUT CLAIM TO ANY PARTICULAR FONT, STYLE, SIZE, OR COLOR.

NO CLAIM IS MADE TO THE EXCLUSIVE RIGHT TO USE "FOOD AND WINE FESTIVAL", APART FROM THE MARK AS SHOWN.

FOR ENTERTAINMENT SERVICES, NAMELY, WINE AND FOOD TASTINGS (U.S. CLS. 100, 101 AND 107).

FIRST USE 2-28-2008; IN COMMERCE 2-28-2008.

3,942,467. SYMMYS LLC, NEW YORK, NY. SN 85-174,991. FILED 11-11-2010.

## Advanced Risk and Portfolio Management

THE MARK CONSISTS OF STANDARD CHARACTERS WITHOUT CLAIM TO ANY PARTICULAR FONT, STYLE, SIZE, OR COLOR.

FOR EDUCATION SERVICES, NAMELY, PROVIDING CLASSES, SEMINARS, CONFERENCES AND WORKSHOPS IN THE FIELDS OF QUANTITATIVE RISK AND PORTFOLIO MANAGEMENT; EDUCATIONAL SERVICES, NAMELY, CONDUCTING CLASSES, SEMINARS, CONFERENCES AND WORKSHOPS IN THE FIELD OF QUANTITATIVE RISK AND PORTFOLIO MANAGEMENT AND DISTRIBUTION OF COURSE AND EDUCATIONAL MATERIALS IN CONNECTION THEREWITH (U.S. CLS. 100, 101 AND 107).

FIRST USE 2-1-2008; IN COMMERCE 2-1-2008.

**CLASS 42—SCIENTIFIC AND COMPUTER SERVICES**

3,942,344. CALIFORNIA ACADEMY OF SCIENCES, SAN FRANCISCO, CA. SN 77-832,206. FILED P.R. 9-22-2009; AM. S.R. 1-25-2011.

**BIODIVERSITY HEALTH INDEX**

THE MARK CONSISTS OF STANDARD CHARACTERS WITHOUT CLAIM TO ANY PARTICULAR FONT, STYLE, SIZE, OR COLOR.

NO CLAIM IS MADE TO THE EXCLUSIVE RIGHT TO USE "HEALTH INDEX", APART FROM THE MARK AS SHOWN.

FOR PROVIDING ONLINE INFORMATION ON THE HEALTH AND DIVERSITY OF THE EARTH'S SPECIES AND ECOSYSTEMS, NAMELY, INFORMATION PERTAINING TO GLOBAL WARMING AND ITS IMPACT ON NATURE AND THE ENVIRONMENT (U.S. CLS. 100 AND 101).

FIRST USE 6-24-2010; IN COMMERCE 6-24-2010.

3,942,347. LYCONIC, LLC, OMAHA, NE. SN 77-850,626. FILED P.R. 10-16-2009; AM. S.R. 1-7-2011.

**SALESGUIDE**

THE MARK CONSISTS OF STANDARD CHARACTERS WITHOUT CLAIM TO ANY PARTICULAR FONT, STYLE, SIZE, OR COLOR.

FOR PROVIDING TEMPORARY USE OF WEB BASED NON-DOWNLOADABLE ONLINE SOFTWARE AND COMPUTER APPLICATIONS FOR SALES CUSTOMER RELATIONSHIP MANAGEMENT IN THE FIELD OF BUILDING AND PREMISES SECURITY MANAGEMENT (U.S. CLS. 100 AND 101).

FIRST USE 10-16-2009; IN COMMERCE 4-1-2010.

3,942,357. MEDNAX SERVICES, INC., SUNRISE, FL. SN 77-893,400. FILED P.R. 12-15-2009; AM. S.R. 12-6-2010.

**QUALITY STEPS**

THE MARK CONSISTS OF STANDARD CHARACTERS WITHOUT CLAIM TO ANY PARTICULAR FONT, STYLE, SIZE, OR COLOR.

**CLASS 42—(Continued).**

OWNER OF U.S. REG. NO. 3,004,919.

FOR PROVIDING ONLINE, NON-DOWNLOADABLE COMPUTER SOFTWARE USED TO ORGANIZE AND TRACK CLINICAL QUALITY IMPROVEMENT PROJECTS AND RELATED DATA AND CLINICAL INFORMATION (U.S. CLS. 100 AND 101).

FIRST USE 2-0-2010; IN COMMERCE 2-0-2010.

3,942,444. GATHER, INC., BOSTON, MA. SN 85-133,322. FILED P.R. 9-20-2010; AM. S.R. 2-22-2011.

**SEARCH DRIVEN MEDIA**

THE MARK CONSISTS OF STANDARD CHARACTERS WITHOUT CLAIM TO ANY PARTICULAR FONT, STYLE, SIZE, OR COLOR.

FOR PROVIDING ONLINE NON-DOWNLOADABLE SOFTWARE WHICH ALLOWS USERS TO CREATE CONTENT IN THE FORM OF TEXT, IMAGES, VIDEOS, SOUND AND MULTIMEDIA IMAGES BASED ON CONSUMER DEMAND FOR SPECIFIC INFORMATION (U.S. CLS. 100 AND 101).

FIRST USE 12-15-2010; IN COMMERCE 12-15-2010.

3,942,449. REUNIONDB, INC., RANCHO SANTA FE, CA. SN 85-144,688. FILED P.R. 10-4-2010; AM. S.R. 1-31-2011.

**ReunionDB**

THE MARK CONSISTS OF STANDARD CHARACTERS WITHOUT CLAIM TO ANY PARTICULAR FONT, STYLE, SIZE, OR COLOR.

FOR PROVIDING A WEBSITE FEATURING NON-DOWNLOADABLE SOFTWARE FOR USE IN DATABASE MANAGEMENT FOR ORGANIZING A GATHERING OF CLASSMATES, FRIENDS, RELATIVES OR COLLEAGUES (U.S. CLS. 100 AND 101).

FIRST USE 10-30-2009; IN COMMERCE 10-30-2009.

**CLASS 42—(Continued).**

3,942,450. WEBER HOSTING & DESIGN, MAPLE GROVE, MN. SN 85-147,296. FILED P.R. 10-7-2010; AM. S.R. 1-28-2010.

weber hosting

THE MARK CONSISTS OF STANDARD CHARACTERS WITHOUT CLAIM TO ANY PARTICULAR FONT, STYLE, SIZE, OR COLOR.

NO CLAIM IS MADE TO THE EXCLUSIVE RIGHT TO USE "HOSTING", APART FROM THE MARK AS SHOWN.

FOR DESIGN, CREATION, HOSTING, MAINTENANCE OF WEBSITES FOR OTHERS (U.S. CLS. 100 AND 101).

FIRST USE 9-14-2010; IN COMMERCE 9-14-2010.

**CLASS 43—(Continued).**

3,942,391. GS ENTERPRISES LLC, SAN ANTONIO, TX. SN 85-017,450. FILED P.R. 4-19-2010; AM. S.R. 1-28-2011.

GREEN BAR

NO CLAIM IS MADE TO THE EXCLUSIVE RIGHT TO USE "BAR", APART FROM THE MARK AS SHOWN. THE COLOR(S) GREEN IS/ARE CLAIMED AS A FEATURE OF THE MARK.

THE MARK CONSISTS OF THE TERMS "GREEN BAR" IN GREEN STYLIZED FONT.

FOR RESTAURANT SERVICES (U.S. CLS. 100 AND 101).

FIRST USE 7-0-2009; IN COMMERCE 7-0-2009.

**CLASS 43—HOTEL AND RESTAURANT SERVICES**

3,942,389. GS ENTERPRISES LLC, SAN ANTONIO, TX. SN 85-017,416. FILED P.R. 4-19-2010; AM. S.R. 1-28-2011.

green bar - healthy food

NO CLAIM IS MADE TO THE EXCLUSIVE RIGHT TO USE "BAR", APART FROM THE MARK AS SHOWN.

THE COLOR(S) RED IS/ARE CLAIMED AS A FEATURE OF THE MARK.

THE MARK CONSISTS OF THE TERM "GREEN BAR - HEALTHY FOOD" IN RED STYLIZED FONT.

FOR RESTAURANT SERVICES (U.S. CLS. 100 AND 101).

FIRST USE 7-0-2009; IN COMMERCE 7-0-2009.

3,942,392. GS ENTERPRISES LLC, SAN ANTONIO, TX. SN 85-017,463. FILED P.R. 4-19-2010; AM. S.R. 1-28-2011.

GREEN BAR

THE MARK CONSISTS OF STANDARD CHARACTERS WITHOUT CLAIM TO ANY PARTICULAR FONT, STYLE, SIZE, OR COLOR.

NO CLAIM IS MADE TO THE EXCLUSIVE RIGHT TO USE "BAR", APART FROM THE MARK AS SHOWN.

FOR RESTAURANT SERVICES (U.S. CLS. 100 AND 101).

FIRST USE 7-0-2009; IN COMMERCE 7-0-2009.

**CLASS 44—MEDICAL, BEAUTY AND AGRICULTURAL SERVICES**

3,942,395. AZ LASER CLINIC, INC., GLENDALE, AZ. SN 85-018,589. FILED P.R. 4-20-2010; AM. S.R. 1-28-2011.

AZLASER SKIN REJUVENATION CENTER

THE MARK CONSISTS OF STANDARD CHARACTERS WITHOUT CLAIM TO ANY PARTICULAR FONT, STYLE, SIZE, OR COLOR.

NO CLAIM IS MADE TO THE EXCLUSIVE RIGHT TO USE "SKIN REJUVENATION CENTER", APART FROM THE MARK AS SHOWN.

FOR LASER HAIR REMOVAL SERVICES; LASER TREATMENTS FOR ACNE, SCARS AND SKIN REGENERATION (U.S. CLS. 100 AND 101).

FIRST USE 6-13-2008; IN COMMERCE 6-13-2008.

3,942,390. GS ENTERPRISES LLC, SAN ANTONIO, TX. SN 85-017,435. FILED P.R. 4-19-2010; AM. S.R. 1-28-2011.

GREEN BAR - HEALTHY FOOD

THE MARK CONSISTS OF STANDARD CHARACTERS WITHOUT CLAIM TO ANY PARTICULAR FONT, STYLE, SIZE, OR COLOR.

NO CLAIM IS MADE TO THE EXCLUSIVE RIGHT TO USE "BAR", APART FROM THE MARK AS SHOWN.

FOR RESTAURANT SERVICES (U.S. CLS. 100 AND 101).

FIRST USE 7-0-2009; IN COMMERCE 7-0-2009.

**CLASS 45—PERSONAL AND LEGAL SERVICES**

3,942,346. ROCTEST LTD., VANCOUVER, BRITISH COLUMBIA, CANADA. SN 77-847,840. FILED P.R. 10-13-2009; AM. S.R. 1-13-2011.

**SHMLIVE**

THE MARK CONSISTS OF STANDARD CHARACTERS WITHOUT CLAIM TO ANY PARTICULAR FONT, STYLE, SIZE, OR COLOR.

FOR INFRASTRUCTURE SURVEILLANCE SERVICE RELATED TO BUILDINGS, BRIDGES, TUNNELS, ROADS, RAILWAYS, HIGHWAYS, WHERE THE DATA IS MADE AVAILABLE ON A WEB SITE (U.S. CLS. 100 AND 101).

FIRST USE 7-22-2009; IN COMMERCE 7-22-2009.

3,942,412. FERNANDEZ, FERNANDO, CAROLINA, PUERTO RICO. SN 85-056,917. FILED P.R. 6-8-2010; AM. S.R. 2-17-2011.

**COVERT INTELLIGENCE**

THE MARK CONSISTS OF STANDARD CHARACTERS WITHOUT CLAIM TO ANY PARTICULAR FONT, STYLE, SIZE, OR COLOR.

**CLASS 45—(Continued).**

NO CLAIM IS MADE TO THE EXCLUSIVE RIGHT TO USE "INTELLIGENCE", APART FROM THE MARK AS SHOWN.

FOR LEGAL SERVICES; PROCESS SERVING; SECURITY AND INVESTIGATIVE SERVICES FOR THE PROTECTION OF PROPERTY AND INDIVIDUALS, NAMELY, SURVEILLANCE SERVICES, WORKERS COMPENSATION FRAUD INVESTIGATION SERVICES, STOLEN VEHICLE TRACKING SERVICES FEATURING GPS TECHNOLOGY, DETECTIVE INVESTIGATION SERVICES FEATURING ANALYSIS OF CRIME SCENES, TRACKS, TRACE EVIDENCE AND FINGERPRINTS, CONDUCTING PRE-EMPLOYMENT BACKGROUND SCREENING AND PERSONAL BACKGROUND INVESTIGATIONS, MISSING PERSONS INVESTIGATION SERVICES, PRIVATE INVESTIGATION SERVICES RELATING TO ONLINE CRIMES, INVESTIGATION SERVICES RELATED TO INSURANCE CLAIMS, FRAUD DETECTION TESTING SERVICES IN THE NATURE OF ADMINISTERING LIE DETECTOR TESTS, PRIVATE INVESTIGATION SERVICES IN THE FIELD OF INFIDELITY; PERSONAL AND SOCIAL SERVICES RENDERED BY OTHERS TO MEET THE NEEDS OF INDIVIDUALS, NAMELY, PRIVATE SECURITY GUARD SERVICES, EXECUTIVE PROTECTION SERVICES AND SECURITY CONSULTATION SERVICES (U.S. CLS. 100 AND 101).

FIRST USE 5-1-2010; IN COMMERCE 5-1-2010.

3,942,455. THE CHILDREN'S PROJECT FOUNDATION, DBA THE CHILDREN'S PROJECT ACADEMY, SANTA BARBARA, CA. SN 85-152,851. FILED P.R. 10-14-2010; AM. S.R. 1-28-2011.

**Foster For America**

THE MARK CONSISTS OF STANDARD CHARACTERS WITHOUT CLAIM TO ANY PARTICULAR FONT, STYLE, SIZE, OR COLOR.

NO CLAIM IS MADE TO THE EXCLUSIVE RIGHT TO USE "FOSTER", APART FROM THE MARK AS SHOWN.

FOR FOSTER CARE (U.S. CLS. 100 AND 101).

FIRST USE 8-20-2010; IN COMMERCE 10-12-2010.

\* \* \* \* \*

# TRADEMARK REGISTRATIONS RENEWED

The designation "U.S. Cl." appearing in this section refers to the U.S. class in effect prior to Sep. 1, 1973 rather than the international class which applies to applications filed on or after that date. For adoption of international classification see notice in the OFFICIAL GAZETTE of Jun. 26, 1973 (911 O.G. TM 210).

81,462.	CATAWBA (STYLIZED). U.S. CL. 7. (INT. CL. 22). REG. 4-11-1911.	727,342.	HI-T-LUBE. U.S. CL. 106. (INT. CL. 40). REG. 2-6-1962.
139,646.	TIFFANY (STYLIZED). U.S. CL. 28. (INT. CLS. 8 AND 14). REG. 2-8-1921.	727,523.	ASTROLITE. U.S. CL. 37. (INT. CL. 16). REG. 2-13-1962.
146,202.	COLONIAL. U.S. CL. 6. (INT. CL. 30). REG. 9-6-1921.	897,406.	BARCO. U.S. CL. 39. (INT. CL. 25). REG. 8-25-1970.
281,291.	MIXMASTER. U.S. CL. 21. (INT. CL. 7). REG. 3-17-1931.	897,507.	CARTIER. U.S. CLS. 100 AND 103. (INT. CLS. 37 AND 42). REG. 8-25-1970.
282,547.	OHMALOY (STYLIZED). U.S. CL. 14. (INT. CL. 6). REG. 4-21-1931.	898,238.	CENTAC. U.S. CL. 23. (INT. CL. 7). REG. 9-8-1970.
385,243.	ARLACEL. U.S. CL. 6. (INT. CL. 1). REG. 2-18-1941.	903,027.	N (STYLIZED). U.S. CL. 37. (INT. CLS. 16, 26 AND 27). REG. 11-24-1970.
386,223.	ROLLING ROCK AND DESIGN. U.S. CL. 48. (INT. CL. 32). REG. 4-1-1941.	904,186.	P AND DESIGN. U.S. CLS. 19 AND 23. (INT. CL. 12). REG. 12-15-1970.
529,452.	RAMON ALLONES FLOR-EXTRA-FINA AND DESIGN. U.S. CL. 17. (INT. CL. 34). REG. 8-22-1950.	905,141.	DORAL. U.S. CL. 35. (INT. CL. 12). REG. 12-29-1970.
538,081.	COLDSPOT (STYLIZED). U.S. CL. 31. (INT. CLS. 7, 11 AND 12). REG. 2-20-1951.	907,852.	DURA-CORE. U.S. CL. 14. (INT. CL. 6). REG. 2-16-1971.
538,938.	TIMSEN (STYLIZED). U.S. CL. 18. (INT. CL. 5). REG. 3-6-1951.	907,855.	PYROTOOL. U.S. CL. 14. (INT. CL. 6). REG. 2-16-1971.
539,056.	BLACK PEARLS. U.S. CL. 11. (INT. CL. 2). REG. 3-6-1951.	907,934.	HAYES AND DESIGN. U.S. CL. 23. (INT. CLS. 6, 7, 8, 9, 11, 12, 16, 21 AND 28). REG. 2-16-1971.
539,165.	KRISPY KREME (STYLIZED). U.S. CL. 46. (INT. CLS. 1, 5, 29, 30, 31 AND 32). REG. 3-13-1951.	907,990.	ARISTO. U.S. CL. 27. (INT. CL. 14). REG. 2-16-1971.
539,215.	LILT (STYLIZED). U.S. CL. 44. (INT. CLS. 5, 8, 10 AND 12). REG. 3-13-1951.	908,188.	LANSON. U.S. CL. 47. (INT. CL. 33). REG. 2-16-1971.
539,254.	ARCTIC (STYLIZED). U.S. CL. 39. (INT. CL. 25). REG. 3-13-1951.	908,283.	LEO AND DESIGN. U.S. CL. 200. REG. 2-16-1971.
544,328.	CANDY LAND AND DESIGN. U.S. CL. 22. (INT. CL. 28). REG. 6-26-1951.	908,555.	MISCELLANEOUS DESIGN. U.S. CL. 26. (INT. CL. 9). REG. 2-23-1971.
552,753.	VULCAN. U.S. CL. 32. (INT. CL. 20). REG. 1-1-1952.	908,600.	FLARE-LOK. U.S. CL. 35. (INT. CL. 17). REG. 2-23-1971.
704,637.	MISCELLANEOUS DESIGN. U.S. CL. 33. (INT. CL. 21). REG. 9-20-1960.	908,674.	MILLIKEN AND DESIGN. U.S. CL. 42. (INT. CLS. 24 AND 27). REG. 2-23-1971.
710,186.	MAGNETICS INC. AND DESIGN. U.S. CL. 21. (INT. CL. 9). REG. 1-24-1961.	908,750.	CARDHU. U.S. CL. 49. (INT. CL. 33). REG. 2-23-1971.
711,605.	SAUCY SUSAN. U.S. CL. 46. (INT. CL. 30). REG. 2-21-1961.	908,843.	IBERIA AIR LINES OF SPAIN. U.S. CL. 105. (INT. CL. 39). REG. 2-23-1971.
711,818.	DOLE. U.S. CL. 23. (INT. CL. 11). REG. 2-28-1961.	909,059.	MUCK. U.S. CL. 23. (INT. CL. 7). REG. 3-2-1971.
711,858.	FEL-COPRENE. U.S. CL. 35. (INT. CL. 17). REG. 2-28-1961.	909,138.	CUSIP. U.S. CL. 38. (INT. CL. 16). REG. 3-2-1971.
711,971.	MOPLEN.	909,332.	SOUTHERN CHRISTMAS SHOW. U.S. CL. 101. (INT. CL. 35). REG. 3-2-1971.
712,390.	SHEAR-SEAL. U.S. CL. 13. (INT. CL. 7). REG. 3-14-1961.	909,366.	THE KEG. U.S. CL. 107. (INT. CL. 41). REG. 3-2-1971.
712,448.	AMP-IN. U.S. CL. 21. (INT. CL. 9). REG. 3-14-1961.	909,538.	100 PLUS. U.S. CL. 23 ONLY. (INT. CL. 8). REG. 3-9-1971.
712,836.	ALLEN-BRADLEY. U.S. CL. 26. (INT. CL. 9). REG. 3-21-1961.	909,544.	ANSUL AUTOMAN. U.S. CL. 26. (INT. CL. 9). REG. 3-9-1971.
713,322.	AGA (STYLIZED). U.S. CL. 2. (INT. CLS. 6, 13, 14, 15, 16, 18, 20, 21, 22 AND 34). REG. 4-4-1961.	909,848.	NOVATEC. INT. CL. 1. (U.S. CL. 1). REG. 3-16-1971.
715,535.	ORIGINAL PABST BLUE RIBBON (STYLIZED). U.S. CL. 48. (INT. CL. 32). REG. 5-16-1961.	910,007.	BLOHM. U.S. CL. 23. (INT. CL. 7). REG. 3-16-1971.
715,541.	SALISBURY PINK. U.S. CL. 50. (INT. CL. 19). REG. 5-16-1961.	910,009.	BELTON (STYLIZED). U.S. CL. 23. (INT. CL. 7). REG. 3-16-1971.
716,085.	GAULIN. U.S. CL. 23. (INT. CL. 7). REG. 5-30-1961.	910,388.	PEARL AND DESIGN. U.S. CL. 23 ONLY. (INT. CL. 7). REG. 3-23-1971.
716,444.	VAC-U-MAX AND DESIGN. U.S. CL. 23. (INT. CL. 7). REG. 6-6-1961.	911,204.	SWIM TIME. U.S. CL. 23. (INT. CL. 7). REG. 4-13-1971.
717,427.	PHILLIES CHEROOT (STYLIZED). U.S. CL. 17. (INT. CL. 34). REG. 6-27-1961.	911,835.	BED-O-COBS (STYLIZED). U.S. CL. 1. (INT. CL. 31). REG. 6-1-1971.
717,603.	GUARDIAN. U.S. CL. 37. (INT. CL. 16). REG. 6-27-1961.	912,306.	SMG. U.S. CL. 14. (INT. CL. 6). REG. 6-8-1971.
717,820.	HEARPHONE. U.S. CL. 21. (INT. CL. 9). REG. 7-4-1961.	915,380.	FREKOTE. U.S. CL. 15. (INT. CL. 4). REG. 6-22-1971.
720,199.	AQUAGUARD. U.S. CL. 6. (INT. CL. 1). REG. 8-22-1961.	916,924.	DUO-FINISH. U.S. CL. 37. (INT. CL. 16). REG. 7-20-1971.
720,401.	OLE SMOKY. U.S. CL. 46. (INT. CLS. 1, 5, 29, 30, 31 AND 32). REG. 8-22-1961.	919,659.	SUCKER-PLUCKER. U.S. CL. 6. (INT. CL. 1). REG. 9-7-1971.
726,412.	CRC SEAL COAT. U.S. CL. 6. (INT. CL. 2). REG. 1-16-1962.	921,089.	DIRT ALARM. U.S. CL. 26. (INT. CL. 9). REG. 9-28-1971.
		921,229.	FROSTED MINI-WHEATS. U.S. CL. 46. (INT. CL. 30). REG. 9-28-1971.
		923,093.	TILE-CLAD. U.S. CL. 16. (INT. CL. 2). REG. 11-2-1971.

925,062. VIBROBLOCK (STYLIZED). U.S. CL. 23. (INT. CL. 7). REG. 12-7-1971.  
 925,200. PHILLIPSP AND DESIGN. U.S. CL. 46. (INT. CL. 29). REG. 12-7-1971.  
 929,014. EYE-STREAM. U.S. CL. 18. (INT. CL. 5). REG. 2-15-1972.  
 929,244. AIRWAY. U.S. CL. 44. (INT. CL. 10). REG. 2-15-1972.  
 930,109. MOONLIGHT. U.S. CL. 46. (INT. CL. 31). REG. 2-29-1972.  
 1,140,234. SLIPSTICK. INT. CL. 7. (U.S. CL. 23). REG. 10-7-1980.  
 1,142,882. MCBRIDE ELECTRIC. INT. CL. 37. (U.S. CL. 103). REG. 12-9-1980.  
 1,145,500. CROWN-ETTE (STYLIZED). INT. CL. 25. (U.S. CL. 39). REG. 1-6-1981.  
 1,146,999. U-LACTIN STANDARD CHARACTER MARK. INT. CL. 3. (U.S. CL. 51). REG. 2-17-1981.  
 1,147,071. PALADIN. INT. CL. 8. (U.S. CL. 23). REG. 2-17-1981.  
 1,147,271. MISCELLANEOUS DESIGN. INT. CL. 28. (U.S. CL. 22). REG. 2-17-1981.  
 1,147,518. MISCELLANEOUS DESIGN. INT. CL. 8. (U.S. CL. 23). REG. 2-24-1981.  
 1,147,591. ENGLANDER. INT. CL. 11. (U.S. CL. 34). REG. 2-24-1981.  
 1,147,662. HBR. INT. CL. 17. (U.S. CL. 50). REG. 2-24-1981.  
 1,147,737. ACTIVIZER. INT. CL. 25. (U.S. CL. 39). REG. 2-24-1981.  
 1,147,776. MISTER TWISTER AND DESIGN. INT. CL. 30. (U.S. CL. 46). REG. 2-24-1981.  
 1,147,929. SANI-AIR (STYLIZED). INT. CLS. 5 AND 11. (U.S. CLS. 6 AND 34). REG. 3-3-1981.  
 1,148,320. MISCELLANEOUS DESIGN. INT. CL. 36. (U.S. CL. 102). REG. 3-10-1981.  
 1,148,432. BIG D AND DESIGN. INT. CL. 18. (U.S. CLS. 3 AND 42). REG. 3-17-1981.  
 1,148,433. BIG D. INT. CL. 18. (U.S. CLS. 3, 23 AND 42). REG. 3-17-1981.  
 1,149,187. THE ORIGINAL KITCHEN SINK AND DESIGN. INT. CL. 42. (U.S. CL. 100). REG. 3-24-1981.  
 1,149,302. COLSON. INT. CL. 9. (U.S. CL. 21). REG. 3-24-1981.  
 1,149,594. STEPTOE. INT. CL. 6. (U.S. CL. 12). REG. 3-31-1981.  
 1,149,605. SIG AND DESIGN. INT. CL. 7 ONLY. (U.S. CLS. 13, 19, 21, 23, 31, 34 AND 35). REG. 3-31-1981.  
 1,149,616. SM-CYCLO. INT. CL. 7. (U.S. CL. 23). REG. 3-31-1981.  
 1,149,746. THE SHOT OF CHAMPIONS STANDARD CHARACTER MARK. INT. CL. 13. (U.S. CL. 9). REG. 3-31-1981.  
 1,149,967. VICTORIA AND DESIGN. INT. CLS. 29 AND 30. (U.S. CL. 46). REG. 3-31-1981.  
 1,150,590. SERRALLES. INT. CL. 33. (U.S. CL. 49). REG. 4-7-1981.  
 1,150,813. STARFLEX AND DESIGN. INT. CL. 7. (U.S. CL. 23). REG. 4-14-1981.  
 1,151,068. SPEEDY CORN. INT. CL. 21. (U.S. CL. 29). REG. 4-14-1981.  
 1,153,162. D AND DESIGN. INT. CL. 18. (U.S. CLS. 3 AND 42). REG. 5-5-1981.  
 1,153,324. COLE'S. INT. CL. 30. (U.S. CL. 46). REG. 5-5-1981.  
 1,153,490. MISCELLANEOUS DESIGN. INT. CL. 42. (U.S. CL. 100). REG. 5-5-1981.  
 1,154,045. MARMOLEUM. INT. CL. 27. (U.S. CL. 20). REG. 5-12-1981.  
 1,154,125. PURE-PRIDE. INT. CL. 31. (U.S. CL. 46). REG. 5-12-1981.  
 1,155,249. CARAFATE. INT. CL. 5. (U.S. CL. 18). REG. 5-26-1981.  
 1,155,334. CAM SPRAY. INT. CL. 7. (U.S. CL. 23). REG. 5-26-1981.  
 1,156,700. KIAWAH ISLAND (STYLIZED). INT. CL. 41. (U.S. CL. 107). REG. 6-2-1981.  
 1,156,993. TRUTZSCHLER AND DESIGN. INT. CLS. 7, 9 AND 11. (U.S. CLS. 23, 26 AND 31). REG. 6-9-1981.  
 1,157,500. GAMESA. INT. CL. 30. (U.S. CL. 46). REG. 6-9-1981.  
 1,158,077. HOT LINE. INT. CL. 16. (U.S. CL. 38). REG. 6-23-1981.  
 1,159,059. RIKEN AND DESIGN. INT. CL. 12. (U.S. CLS. 19, 21, 23, 31, 35 AND 44). REG. 6-30-1981.  
 1,159,098. CONDOMINIUM CONNECTION. INT. CLS. 16 AND 36. (U.S. CLS. 38, 101 AND 102). REG. 6-30-1981.  
 1,159,469. THE CAPTION CENTER. INT. CL. 41. (U.S. CL. 107). REG. 6-30-1981.  
 1,161,210. COUSIN WILLIE'S. INT. CL. 31. (U.S. CL. 46). REG. 7-14-1981.  
 1,162,689. PLAYFUL PALS. INT. CL. 16. (U.S. CL. 37). REG. 7-28-1981.  
 1,162,957. MARUKAWA (STYLIZED). INT. CL. 30. (U.S. CL. 46). REG. 7-28-1981.  
 1,163,531. HELM-PAK. INT. CL. 9. (U.S. CL. 26). REG. 8-4-1981.  
 1,164,772. M AND DESIGN. INT. CL. 28. (U.S. CL. 22). REG. 8-11-1981.  
 1,165,246. HURST. INT. CL. 7. (U.S. CL. 23). REG. 8-18-1981.  
 1,165,405. CHANNEL-CEIL. INT. CL. 11. (U.S. CL. 31). REG. 8-18-1981.  
 1,166,031. PRECISELY RIGHT. INT. CL. 3. (U.S. CL. 51). REG. 8-25-1981.  
 1,166,231. PULSONIC. INT. CL. 9. (U.S. CL. 21). REG. 8-25-1981.  
 1,166,342. JAGUAR. INT. CL. 9. (U.S. CL. 26). REG. 8-25-1981.  
 1,166,686. BIG BOY AND DESIGN. INT. CL. 29. (U.S. CL. 46). REG. 8-25-1981.  
 1,167,500. PRESSMAN AND DESIGN. INT. CL. 28. (U.S. CL. 22). REG. 9-1-1981.  
 1,172,010. MICONIC. INT. CLS. 7 AND 9. (U.S. CLS. 23 AND 26). REG. 10-6-1981.  
 1,172,971. E-Z FEED. INT. CL. 9. (U.S. CL. 34). REG. 10-13-1981.  
 1,175,332. WELCOME HOME BABY. INT. CL. 28. (U.S. CL. 22). REG. 10-27-1981.  
 1,177,827. TRUCKRAFT AND DESIGN. INT. CLS. 7 AND 12 ONLY. (U.S. CLS. 19, 21 AND 23). REG. 11-17-1981.  
 1,178,406. WILSON. INT. CL. 33. (U.S. CL. 49). REG. 11-17-1981.  
 1,178,644. OCEANEERING AND DESIGN. INT. CL. 42. (U.S. CL. 100). REG. 11-17-1981.  
 1,180,293. N (STYLIZED). INT. CL. 25. (U.S. CLS. 22 AND 39). REG. 12-1-1981.  
 1,182,040. LAWYERS DIARY AND MANUAL INCLUDING BAR DIRECTORY OF NEW JERSEY. INT. CL. 16. (U.S. CLS. 2, 5, 22, 23, 29, 37, 38 AND 50). REG. 12-15-1981.  
 1,183,143. LANGNESE (STYLIZED). INT. CL. 30. (U.S. CL. 46). REG. 12-22-1981.  
 1,183,781. MISCELLANEOUS DESIGN. INT. CL. 19. (U.S. CL. 12). REG. 12-29-1981.  
 1,185,339. SEAGUARD (STYLIZED). INT. CL. 2. (U.S. CL. 16). REG. 1-12-1982.  
 1,185,565. FLEXOLITE. INT. CL. 9. (U.S. CL. 26). REG. 1-12-1982.  
 1,186,445. OHIO AND DESIGN. INT. CL. 7. (U.S. CL. 23). REG. 1-19-1982.  
 1,188,237. URBEK. INT. CL. 42. (U.S. CL. 100). REG. 1-26-1982.  
 1,582,456. MAXI-STACK. INT. CL. 12. (U.S. CL. 19). REG. 2-13-1990.  
 1,610,370. GKN (STYLIZED). INT. CLS. 6, 7, 12 AND 17. (U.S. CLS. 1, 2, 5, 12, 13, 14, 19, 21, 23, 25, 31, 34, 35 AND 50). REG. 8-21-1990.  
 1,610,979. EYERENUE COMPLEX. INT. CL. 3. (U.S. CL. 51). REG. 8-28-1990.  
 1,611,246. MISCELLANEOUS DESIGN. INT. CL. 25 ONLY. (U.S. CLS. 22 AND 39). REG. 8-28-1990.  
 1,611,290. PARK B. SMITH LTD. (STYLIZED). INT. CLS. 24 AND 27. (U.S. CL. 42). REG. 8-28-1990.  
 1,611,327. RUBY'S AND DESIGN. INT. CL. 25. (U.S. CL. 39). REG. 8-28-1990.  
 1,611,556. MISCELLANEOUS DESIGN. INT. CLS. 37 AND 42. (U.S. CLS. 101 AND 103). REG. 8-28-1990.  
 1,611,594. READING RAINBOW AND DESIGN. INT. CL. 41. (U.S. CL. 107). REG. 8-28-1990.  
 1,612,001. JUST-JEWELS (STYLIZED). INT. CL. 14. (U.S. CL. 28). REG. 9-4-1990.  
 1,613,150. ALF-A'COBS. INT. CL. 31. (U.S. CL. 1). REG. 9-11-1990.  
 1,613,152. PEL-O'COBS. INT. CL. 31. (U.S. CL. 1). REG. 9-11-1990.  
 1,613,674. CONTROL. INT. CL. 9. (U.S. CL. 21). REG. 9-18-1990.  
 1,613,724. 205. INT. CL. 12. (U.S. CL. 19). REG. 9-18-1990.

- 1,617,781. MISCELLANEOUS DESIGN. INT. CL. 29. (U.S. CL. 46). REG. 10-16-1990.
- 1,617,967. DERCO. INT. CLS. 37 AND 42. (U.S. CLS. 100, 101, 103 AND 106). REG. 10-16-1990.
- 1,618,197. PREMIUM. INT. CL. 11. (U.S. CL. 34). REG. 10-16-1990.
- 1,625,653. A AND DESIGN. INT. CL. 7. (U.S. CL. 23). REG. 12-4-1990.
- 1,625,834. ISOCENTRIC (STYLIZED). INT. CL. 10. (U.S. CL. 44). REG. 12-4-1990.
- 1,626,353. KIRKWOOD AND DESIGN. INT. CLS. 41 AND 42. (U.S. CLS. 100 AND 107). REG. 12-4-1990.
- 1,626,504. R-M AND DESIGN. INT. CLS. 1, 2 AND 3. (U.S. CLS. 1, 4, 5, 6, 10, 16, 26, 46, 50, 51 AND 52). REG. 12-11-1990.
- 1,629,793. MISCELLANEOUS DESIGN. INT. CL. 5. (U.S. CL. 18). REG. 1-1-1991.
- 1,630,419. CRITICAL BEHAVIORS INVENTORY. INT. CL. 42. (U.S. CL. 100). REG. 1-1-1991.
- 1,630,455. MISCO (STYLIZED). INT. CL. 42. (U.S. CL. 101). REG. 1-1-1991.
- 1,630,671. BUDGE B (STYLIZED). INT. CL. 12 ONLY. (U.S. CLS. 19, 21, 23, 31, 35 AND 44). REG. 1-8-1991.
- 1,630,813. PERSONAL COMMISSION. INT. CL. 16. (U.S. CL. 38). REG. 1-8-1991.
- 1,631,659. NOTEWORTHY. INT. CL. 22. (U.S. CL. 2). REG. 1-15-1991.
- 1,631,936. RUBY'S. INT. CL. 42. (U.S. CL. 100). REG. 1-15-1991.
- 1,632,122. MISCELLANEOUS DESIGN. INT. CL. 5. (U.S. CL. 18). REG. 1-22-1991.
- 1,632,165. COLOR KING 2000. INT. CL. 7. (U.S. CL. 23). REG. 1-22-1991.
- 1,632,334. SIA. INT. CL. 16. (U.S. CLS. 2, 5, 22, 23, 29, 37, 38 AND 50). REG. 1-22-1991.
- 1,632,815. SYSTEM. INT. CL. 1. (U.S. CL. 6). REG. 1-29-1991.
- 1,634,131. MISCELLANEOUS DESIGN. INT. CLS. 24, 25 AND 41. (U.S. CLS. 22, 39, 42, 50 AND 107). REG. 2-5-1991.
- 1,634,188. ALPHA AND DESIGN. INT. CL. 25. (U.S. CL. 39). REG. 2-5-1991.
- 1,634,318. AUTOFACTS. INT. CLS. 35 AND 42. (U.S. CLS. 100 AND 101). REG. 2-5-1991.
- 1,634,368. WATER EQUIPMENT TECHNOLOGIES, INC.. INT. CLS. 37 AND 40. (U.S. CLS. 103 AND 106). REG. 2-5-1991.
- 1,634,676. CROWN. INT. CLS. 9 AND 12. (U.S. CLS. 19 AND 21). REG. 2-12-1991.
- 1,634,760. MISCELLANEOUS DESIGN. INT. CL. 12. (U.S. CL. 19). REG. 2-12-1991.
- 1,634,789. DRAW AND STORE. INT. CL. 16. (U.S. CL. 37). REG. 2-12-1991.
- 1,635,392. RUN/MASTER. INT. CL. 9. (U.S. CL. 38). REG. 2-19-1991.
- 1,635,425. DEL-NAT. INT. CLS. 12 AND 42. (U.S. CLS. 19, 35 AND 101). REG. 2-19-1991.
- 1,635,436. DELTAH. INT. CL. 14. (U.S. CLS. 2, 27, 28 AND 50). REG. 2-19-1991.
- 1,635,469. ELEGANT WRITER. INT. CL. 16. (U.S. CL. 37). REG. 2-19-1991.
- 1,635,495. AQUALINER. INT. CL. 19. (U.S. CL. 12). REG. 2-19-1991.
- 1,635,510. TECH-STEP. INT. CL. 20. (U.S. CL. 32). REG. 2-19-1991.
- 1,635,581. A AUSTRALIA AND DESIGN. INT. CL. 28. (U.S. CL. 22). REG. 2-19-1991.
- 1,635,584. JACK NICKLAUS (STYLIZED). INT. CL. 28. (U.S. CL. 22). REG. 2-19-1991.
- 1,635,598. MACFARMS. INT. CLS. 29 AND 30. (U.S. CL. 46). REG. 2-19-1991.
- 1,635,602. FATHER TIME, PRES. GEO. EXPERIENCE, SEC. DEATH & TAXES, TREAS.. INT. CL. 29. (U.S. CL. 46). REG. 2-19-1991.
- 1,635,618. DODGER DOG. INT. CL. 30. (U.S. CL. 46). REG. 2-19-1991.
- 1,635,682. TRANSAMERICA (STYLIZED). INT. CL. 36 ONLY. (U.S. CLS. 100, 101 AND 102). REG. 2-19-1991.
- 1,635,709. NATIONAL. INT. CLS. 37 AND 42 ONLY. (U.S. CLS. 100, 101, 103 AND 106). REG. 2-19-1991.
- 1,635,836. OPTION FIT. INT. CL. 42. (U.S. CLS. 100 AND 101). REG. 2-19-1991.
- 1,635,845. MCPRODUCT (STYLIZED). INT. CL. 42. (U.S. CLS. 101 AND 107). REG. 2-19-1991.
- 1,635,885. VANGUARD. INT. CL. 5 ONLY. (U.S. CL. 6 ONLY). REG. 2-26-1991.
- 1,635,900. ARID-X. INT. CL. 1. (U.S. CL. 6). REG. 2-26-1991.
- 1,635,911. THERAPPE (STYLIZED). INT. CL. 3. (U.S. CL. 52). REG. 2-26-1991.
- 1,635,928. PROSYSTEM. INT. CL. 5. (U.S. CL. 18). REG. 2-26-1991.
- 1,635,948. CLEAR IMAGE. INT. CL. 5. (U.S. CLS. 18 AND 44). REG. 2-26-1991.
- 1,636,008. OMEGAPHONE. INT. CL. 9. (U.S. CLS. 21 AND 26). REG. 2-26-1991.
- 1,636,009. OMEGASNAP. INT. CL. 9. (U.S. CL. 38). REG. 2-26-1991.
- 1,636,036. TRAILMASTER. INT. CL. 9. (U.S. CL. 26). REG. 2-26-1991.
- 1,636,057. ASTOTHERM. INT. CL. 10. (U.S. CL. 44). REG. 2-26-1991.
- 1,636,105. MICHEL HERBELIN AND DESIGN. INT. CL. 14. (U.S. CLS. 27 AND 28). REG. 2-26-1991.
- 1,636,109. COLE HAAN. INT. CL. 18 ONLY. (U.S. CLS. 3 AND 28). REG. 2-26-1991.
- 1,636,126. COPYLABEL. INT. CL. 16. (U.S. CL. 37). REG. 2-26-1991.
- 1,636,152. ZETPOL. INT. CL. 17. (U.S. CL. 35). REG. 2-26-1991.
- 1,636,162. CROSSVILLE CERAMICS AND DESIGN. INT. CL. 19. (U.S. CL. 12). REG. 2-26-1991.
- 1,636,173. BALL STATE. INT. CL. 21. (U.S. CLS. 2, 30 AND 33). REG. 2-26-1991.
- 1,636,200. C.M. & COMPANY. INT. CL. 25. (U.S. CL. 39). REG. 2-26-1991.
- 1,636,243. CARSON'S RIBS. INT. CL. 29. (U.S. CL. 46). REG. 2-26-1991.
- 1,636,261. OSO SWEET. INT. CL. 31. (U.S. CL. 46). REG. 2-26-1991.
- 1,636,284. NAMEPOWER AND DESIGN. INT. CL. 35. (U.S. CL. 101). REG. 2-26-1991.
- 1,636,358. WERNER ENTERPRISES AND DESIGN. INT. CL. 39. (U.S. CL. 105). REG. 2-26-1991.
- 1,636,381. ROPE-AEROBICS (STYLIZED). INT. CL. 41. (U.S. CL. 107). REG. 2-26-1991.
- 1,636,407. REVEL RED RIVER REVEL ARTS FESTIVAL (STYLIZED). INT. CL. 41. (U.S. CL. 107). REG. 2-26-1991.
- 1,636,589. IRONROOTS. INT. CL. 1. (U.S. CL. 10). REG. 3-5-1991.
- 1,636,595. BIO-LASTIC. INT. CL. 2. (U.S. CLS. 1, 6 AND 16). REG. 3-5-1991.
- 1,636,598. WINNING STREAK. INT. CL. 2. (U.S. CL. 16). REG. 3-5-1991.
- 1,636,620. ALLEN EDWARDS. INT. CL. 3. (U.S. CLS. 51 AND 52). REG. 3-5-1991.
- 1,636,812. MEDGRAPHICS. INT. CL. 10. (U.S. CLS. 26 AND 44). REG. 3-5-1991.
- 1,636,896. FABRIKRAFT. INT. CL. 16. (U.S. CL. 38). REG. 3-5-1991.
- 1,636,931. SPELMAN COLLEGE. INT. CL. 20. (U.S. CLS. 2, 32 AND 50). REG. 3-5-1991.
- 1,636,968. THE THISTLE & SHAMROCK. INT. CL. 25. (U.S. CL. 39). REG. 3-5-1991.
- 1,636,996. FOXEE. INT. CL. 28. (U.S. CL. 22). REG. 3-5-1991.
- 1,637,203. WOODWORKER'S SUPPLY. INT. CL. 42. (U.S. CL. 101). REG. 3-5-1991.
- 1,637,236. IRONMIND. INT. CL. 42. (U.S. CL. 101). REG. 3-5-1991.
- 1,637,355. NOVO NORDISK. INT. CLS. 5 AND 10. (U.S. CLS. 18 AND 44). REG. 3-12-1991.
- 1,637,531. HALOPIKA. INT. CL. 11. (U.S. CL. 21). REG. 3-12-1991.
- 1,637,824. BANCTRUST (STYLIZED). INT. CL. 36. (U.S. CLS. 101 AND 102). REG. 3-12-1991.
- 1,638,071. MISCELLANEOUS DESIGN. INT. CLS. 5 AND 30 ONLY. (U.S. CLS. 18 AND 46). REG. 3-19-1991.
- 1,638,191. APOLLO AND DESIGN. INT. CLS. 9, 11, 12, 18, 25 AND 28. (U.S. CLS. 3, 19, 21, 22, 26 AND 39). REG. 3-19-1991.
- 1,638,205. VAREX. INT. CL. 9. (U.S. CLS. 21, 23, 26, 36 AND 38). REG. 3-19-1991.
- 1,638,782. PHOTOSOL. INT. CL. 1. (U.S. CLS. 1, 5, 6, 10, 26 AND 46). REG. 3-26-1991.
- 1,638,835. ARMOR-PLATE. INT. CL. 4. (U.S. CL. 15). REG. 3-26-1991.
- 1,638,913. MISCELLANEOUS DESIGN. INT. CL. 9. (U.S. CLS. 21 AND 26). REG. 3-26-1991.



- 1,638,977. CODAN. INT. CL. 10. (U.S. CL. 44). REG. 3-26-1991.
- 1,639,009. KE (STYLIZED). INT. CL. 12. (U.S. CL. 19). REG. 3-26-1991.
- 1,639,165. SPELMAN COLLEGE. INT. CL. 25. (U.S. CL. 39). REG. 3-26-1991.
- 1,639,509. ACCUROD. INT. CL. 6. (U.S. CLS. 13 AND 14). REG. 4-2-1991.
- 1,640,229. SCOTT. INT. CL. 7. (U.S. CLS. 23 AND 38). REG. 4-9-1991.
- 1,640,256. ASHMONT. INT. CL. 8. (U.S. CLS. 23 AND 28). REG. 4-9-1991.
- 1,641,229. NEW YORK JURY VERDICT REVIEW AND ANALYSIS. INT. CL. 16. (U.S. CL. 38). REG. 4-16-1991.
- 1,641,257. TIGERSOFTWARE. INT. CL. 16. (U.S. CL. 38). REG. 4-16-1991.
- 1,641,434. MAUI MOUNTAIN. INT. CL. 30. (U.S. CL. 46). REG. 4-16-1991.
- 1,641,716. ENDO CLIP. INT. CL. 10. (U.S. CL. 44). REG. 4-16-1991.
- 1,641,842. DYNA-PRO. INT. CL. 2. (U.S. CLS. 6, 11 AND 16). REG. 4-23-1991.
- 1,642,267. HASEKO AND DESIGN. INT. CLS. 36 AND 37. (U.S. CLS. 100, 101, 102 AND 103). REG. 4-23-1991.
- 1,642,742. MISCELLANEOUS DESIGN. INT. CL. 14. (U.S. CL. 28). REG. 4-30-1991.
- 1,642,909. CICADA. INT. CL. 28. (U.S. CL. 22). REG. 4-30-1991.
- 1,642,929. DEL HOGAR. INT. CL. 29. (U.S. CL. 46). REG. 4-30-1991.
- 1,642,954. CLASSIC CARAMEL AND DESIGN. INT. CL. 30. (U.S. CL. 46). REG. 4-30-1991.
- 1,643,146. OUTSIDE VIEW. INT. CL. 9. (U.S. CL. 38). REG. 4-30-1991.
- 1,643,163. PAYRIGHT. INT. CL. 35. (U.S. CL. 101). REG. 4-30-1991.
- 1,643,762. LUCKY MAN AND DESIGN. INT. CL. 29. (U.S. CL. 46). REG. 5-7-1991.
- 1,645,177. NEW INTERNATIONAL VERSION. INT. CL. 16. (U.S. CL. 38). REG. 5-21-1991.
- 1,646,268. IF WE DON'T SELL YOUR HOUSE, ERA WILL BUY IT!. INT. CL. 36. (U.S. CLS. 101 AND 102). REG. 5-28-1991.
- 1,646,279. ESP. INT. CL. 37. (U.S. CL. 103). REG. 5-28-1991.
- 1,646,357. FRUGAL'S. INT. CL. 42. (U.S. CLS. 100 AND 101). REG. 5-28-1991.
- 1,646,411. MERRY TAILS AND DESIGN. INT. CL. 42. (U.S. CL. 101). REG. 5-28-1991.
- 1,646,493. BARACUTA. INT. CL. 25. (U.S. CL. 39). REG. 5-28-1991.
- 1,646,739. LIMITED EDITIONS. INT. CL. 9. (U.S. CL. 26). REG. 6-4-1991.
- 1,646,862. NOMIX. INT. CL. 19. (U.S. CL. 12). REG. 6-4-1991.
- 1,646,910. DKNY. INT. CL. 25. (U.S. CL. 39). REG. 6-4-1991.
- 1,647,425. FINE GARDENING. INT. CL. 16. (U.S. CL. 38). REG. 6-11-1991.
- 1,647,937. NAMCO. INT. CL. 9. (U.S. CLS. 21 AND 26). REG. 6-18-1991.
- 1,648,275. KID-TESTED MOTHER-APPROVED. INT. CL. 30. (U.S. CL. 46). REG. 6-18-1991.
- 1,648,481. SO SOFT. INT. CL. 2. (U.S. CL. 16). REG. 6-18-1991.
- 1,648,815. NOVATIONS. INT. CL. 16. (U.S. CLS. 37 AND 38). REG. 6-25-1991.
- 1,650,293. PURINA ONE STANDARD CHARACTER MARK. INT. CL. 31. (U.S. CL. 46). REG. 7-9-1991.
- 1,650,944. PEDRO'S PICK. INT. CL. 30. (U.S. CL. 46). REG. 7-16-1991.
- 1,651,397. LIGHTSTAT. INT. CL. 9. (U.S. CLS. 21 AND 26). REG. 7-23-1991.
- 1,651,838. MISCELLANEOUS DESIGN. INT. CL. 42. (U.S. CL. 100). REG. 7-23-1991.
- 1,652,698. MISCELLANEOUS DESIGN. INT. CL. 42. (U.S. CL. 100). REG. 7-30-1991.
- 1,652,997. VUE-GARD. INT. CL. 11. (U.S. CLS. 13 AND 34). REG. 8-6-1991.
- 1,653,014. AQUAMATIC. INT. CL. 14. (U.S. CLS. 27 AND 28). REG. 8-6-1991.
- 1,655,680. SAMPLER. INT. CL. 30. (U.S. CL. 46). REG. 9-3-1991.
- 1,656,408. SHARP'S. INT. CL. 32. (U.S. CLS. 45 AND 49). REG. 9-10-1991.
- 1,656,592. MISCELLANEOUS DESIGN. INT. CL. 6. (U.S. CL. 13). REG. 9-10-1991.
- 1,657,089. MOORLIFE. INT. CL. 2. (U.S. CL. 16). REG. 9-17-1991.
- 1,657,807. EUROMIST. INT. CL. 21. (U.S. CLS. 2, 13, 23, 29, 30, 33, 40 AND 50). REG. 9-17-1991.
- 1,658,250. DURATEX. INT. CL. 24. (U.S. CL. 42). REG. 9-24-1991.
- 1,659,185. RIGHT TURN. INT. CL. 42. (U.S. CL. 100). REG. 10-1-1991.
- 1,661,596. TOUGHWEAVE. INT. CL. 10. (U.S. CL. 44). REG. 10-22-1991.
- 1,662,209. SWIM-LIFT. INT. CL. 7. (U.S. CL. 23). REG. 10-29-1991.
- 1,662,739. FLEX/FIXED. INT. CL. 36. (U.S. CL. 102). REG. 10-29-1991.
- 1,663,162. LSI. INT. CL. 6. (U.S. CL. 13). REG. 11-5-1991.
- 1,663,533. MAGNIFICENT SEVEN. INT. CL. 29. (U.S. CL. 46). REG. 11-5-1991.
- 1,663,934. PLYMOUTH TUBE. INT. CL. 6. (U.S. CLS. 13 AND 14). REG. 11-12-1991.
- 1,664,472. VOICESTRA. INT. CL. 41. (U.S. CL. 107). REG. 11-12-1991.
- 1,665,789. THE BLACK CAMEO COREEN SIMPSON AND DESIGN. INT. CL. 14. (U.S. CL. 28). REG. 11-26-1991.
- 1,668,253. LEONORE DOSKOW. INT. CL. 14 ONLY. (U.S. CLS. 2, 27, 28 AND 50). REG. 12-17-1991.
- 1,668,397. SYSTEM H. CUNIER. INT. CL. 10. (U.S. CL. 44). REG. 12-17-1991.
- 1,669,374. JAY STRONGWATER. INT. CL. 14. (U.S. CL. 28). REG. 12-24-1991.
- 1,671,412. FAST-TRACK. INT. CL. 42. (U.S. CL. 100). REG. 1-7-1992.
- 1,671,572. THROAT COAT. INT. CL. 5. (U.S. CLS. 18 AND 46). REG. 1-14-1992.
- 1,672,180. GAVILAN'S. INT. CL. 42. (U.S. CL. 101). REG. 1-14-1992.
- 1,673,552. FLOMO. INT. CL. 28. (U.S. CL. 22). REG. 1-28-1992.
- 1,674,293. GEAR FOR SPORTS. INT. CL. 25. (U.S. CL. 39). REG. 2-4-1992.
- 1,675,725. HANDY-GRIP. INT. CL. 9. (U.S. CL. 26). REG. 2-18-1992.
- 1,676,160. WAH LUM KUNG-FU AND DESIGN. INT. CL. 41. (U.S. CL. 107). REG. 2-18-1992.
- 1,676,169. TRIBE (STYLIZED). INT. CL. 41. (U.S. CL. 107). REG. 2-18-1992.
- 1,676,769. THE JEWISH ADVOCATE. INT. CL. 16. (U.S. CL. 38). REG. 2-25-1992.
- 2,321,774. AVALANCHE. INT. CL. 11. (U.S. CLS. 13, 21, 23, 31 AND 34). REG. 2-22-2000.
- 2,324,023. MINI MAKE-UP PLANNER. INT. CLS. 3 AND 18. (U.S. CLS. 1, 2, 3, 4, 6, 22, 41, 50, 51 AND 52). REG. 2-29-2000.
- 2,359,669. BERINGER AND DESIGN. INT. CL. 12. (U.S. CLS. 19, 21, 23, 31, 35 AND 44). REG. 6-20-2000.
- 2,363,731. OPIN. INT. CL. 36. (U.S. CLS. 100, 101 AND 102). REG. 7-4-2000.
- 2,370,644. E.O. WOOD CO.. INT. CL. 17. (U.S. CLS. 1, 5, 12, 13, 35 AND 50). REG. 7-25-2000.
- 2,370,645. RIGID-WRAP. INT. CL. 17. (U.S. CLS. 1, 5, 12, 13, 35 AND 50). REG. 7-25-2000.
- 2,372,391. HOPE.PROGRESS.ANSWERS. INT. CLS. 16, 36 AND 41. (U.S. CLS. 2, 5, 22, 23, 29, 37, 38, 50, 100, 101, 102 AND 107). REG. 8-1-2000.
- 2,373,832. KEY-SNAP. INT. CL. 6. (U.S. CLS. 2, 12, 13, 14, 23, 25 AND 50). REG. 8-1-2000.
- 2,373,935. COLOR WORKSHOP. INT. CL. 16. (U.S. CLS. 2, 5, 22, 23, 29, 37, 38 AND 50). REG. 8-1-2000.
- 2,374,704. SLOT CITY. INT. CL. 9. (U.S. CLS. 21, 23, 26, 36 AND 38). REG. 8-8-2000.
- 2,374,943. G 2 R GAMES TO REMEMBER (STYLIZED). INT. CL. 28. (U.S. CLS. 22, 23, 38 AND 50). REG. 8-8-2000.
- 2,375,827. DREAMDOG. INT. CL. 16. (U.S. CLS. 2, 5, 22, 23, 29, 37, 38 AND 50). REG. 8-8-2000.
- 2,376,386. LIQUISYSTEMS. INT. CL. 20. (U.S. CLS. 2, 13, 22, 25, 32 AND 50). REG. 8-15-2000.
- 2,376,727. E (STYLIZED). INT. CLS. 9, 40 AND 42. (U.S. CLS. 21, 23, 26, 36, 38, 100, 101, 103 AND 106). REG. 8-15-2000.
- 2,377,000. PARTY WITH A PURPOSE. INT. CL. 36. (U.S. CLS. 100, 101 AND 102). REG. 8-15-2000.
- 2,377,615. DIAMOND LEGENDS. INT. CL. 41. (U.S. CLS. 100, 101 AND 107). REG. 8-15-2000.

- 2,377,795. ADDCO. INT. CL. 12. (U.S. CLS. 19, 21, 23, 31, 35 AND 44). REG. 8-15-2000.
- 2,378,264. FM CYBERSPACE. INT. CL. 9 ONLY. (U.S. CLS. 21, 23, 26, 36 AND 38). REG. 8-15-2000.
- 2,378,772. BEACHES BY MICHAEL VIE AND DESIGN. INT. CL. 3. (U.S. CLS. 1, 4, 6, 50, 51 AND 52). REG. 8-22-2000.
- 2,379,239. NEXT5 INTERACTIVE (STYLIZED). INT. CL. 42. (U.S. CLS. 100 AND 101). REG. 8-22-2000.
- 2,379,503. 10 MINUTE GUIDE TO. INT. CL. 16. (U.S. CLS. 2, 5, 22, 23, 29, 37, 38 AND 50). REG. 8-22-2000.
- 2,379,773. ALFANI. INT. CL. 25. (U.S. CLS. 22 AND 39). REG. 8-22-2000.
- 2,380,089. PRIVATE EXCHANGE. INT. CL. 36. (U.S. CLS. 100, 101 AND 102). REG. 8-22-2000.
- 2,380,090. INVESTMENT MONITOR. INT. CL. 36. (U.S. CLS. 100, 101 AND 102). REG. 8-22-2000.
- 2,380,526. REDBACK. INT. CL. 7. (U.S. CLS. 13, 19, 21, 23, 31, 34 AND 35). REG. 8-29-2000.
- 2,380,618. ALL WEATHER WINDOWS THE ENERGY SAVER AND DESIGN. INT. CL. 19. (U.S. CLS. 1, 12, 33 AND 50). REG. 8-29-2000.
- 2,380,824. GWALTNEY (STYLIZED). INT. CL. 29. (U.S. CL. 46). REG. 8-29-2000.
- 2,381,053. DEL MAR. INT. CL. 11. (U.S. CLS. 13, 21, 23, 31 AND 34). REG. 8-29-2000.
- 2,381,546. DURATECH. INT. CL. 6. (U.S. CLS. 2, 12, 13, 14, 23, 25 AND 50). REG. 8-29-2000.
- 2,381,680. WEBSEM. INT. CL. 9. (U.S. CLS. 21, 23, 26, 36 AND 38). REG. 8-29-2000.
- 2,381,810. CARNIVAL AND DESIGN. INT. CL. 18 ONLY. (U.S. CLS. 1, 2, 3, 22 AND 41). REG. 8-29-2000.
- 2,382,127. PAYFORMANCE. INT. CLS. 35 AND 36. (U.S. CLS. 100, 101 AND 102). REG. 9-5-2000.
- 2,382,147. LBI LAW & BUSINESS INSTITUTE. INT. CL. 16. (U.S. CLS. 2, 5, 22, 23, 29, 37, 38 AND 50). REG. 9-5-2000.
- 2,384,154. LA BY DESIGN. INT. CL. 35. (U.S. CLS. 100, 101 AND 102). REG. 9-5-2000.
- 2,384,246. AHEAD CASUALS. INT. CL. 25. (U.S. CLS. 22 AND 39). REG. 9-5-2000.
- 2,384,421. COUNTRY HOME CREATIONS. INT. CL. 30. (U.S. CL. 46). REG. 9-12-2000.
- 2,385,342. APARTMENT PRO'S. INT. CL. 39. (U.S. CLS. 100 AND 105). REG. 9-12-2000.
- 2,385,690. A.W.O.L.. INT. CL. 38. (U.S. CLS. 100, 101 AND 104). REG. 9-12-2000.
- 2,388,741. SANTA CLAUS. INT. CL. 35. (U.S. CLS. 100, 101 AND 102). REG. 9-19-2000.
- 2,389,800. CAFE RIO AND DESIGN. INT. CL. 42. (U.S. CLS. 100 AND 101). REG. 9-26-2000.
- 2,390,593. FM CYBRARIAN. INT. CL. 9 ONLY. (U.S. CLS. 21, 23, 26, 36 AND 38). REG. 9-26-2000.
- 2,391,796. NCR AND DESIGN. INT. CLS. 37 AND 42. (U.S. CLS. 100, 101, 103 AND 106). REG. 10-3-2000.
- 2,392,196. DOLE PREMIUM SELECT. INT. CL. 31. (U.S. CLS. 1 AND 46). REG. 10-3-2000.
- 2,393,193. KENNY ROGERS ROASTERS. INT. CLS. 29 AND 42. (U.S. CLS. 46, 100 AND 101). REG. 10-10-2000.
- 2,393,821. BOLERO. INT. CL. 10. (U.S. CLS. 26, 39 AND 44). REG. 10-10-2000.
- 2,394,140. SUPERGLIDE. INT. CL. 9. (U.S. CLS. 21, 23, 26, 36 AND 38). REG. 10-10-2000.
- 2,394,306. MAGNA BLOC + - - + AND DESIGN. INT. CL. 10. (U.S. CLS. 26, 39 AND 44). REG. 10-10-2000.
- 2,395,153. 24HOURFITNESS.COM. INT. CL. 42. (U.S. CLS. 100 AND 101). REG. 10-17-2000.
- 2,395,173. NDI. INT. CL. 9. (U.S. CLS. 21, 23, 26, 36 AND 38). REG. 10-17-2000.
- 2,396,146. CALYPSO. INT. CL. 10. (U.S. CLS. 26, 39 AND 44). REG. 10-17-2000.
- 2,400,184. AMPRO. INT. CL. 3. (U.S. CLS. 1, 4, 6, 50, 51 AND 52). REG. 10-31-2000.
- 2,402,380. OVERTONE. INT. CL. 17. (U.S. CLS. 1, 5, 12, 13, 35 AND 50). REG. 11-7-2000.
- 2,404,519. SYMPHONY. INT. CL. 17. (U.S. CLS. 1, 5, 12, 13, 35 AND 50). REG. 11-14-2000.
- 2,405,492. LET'S GET READY TO RUMBLE. INT. CLS. 35 AND 41. (U.S. CLS. 100, 101, 102 AND 107). REG. 11-21-2000.
- 2,407,132. CPG. INT. CLS. 35 AND 41. (U.S. CLS. 100, 101, 102 AND 107). REG. 11-21-2000.
- 2,407,870. WHO'S YOUR DADDY. INT. CL. 25. (U.S. CLS. 22 AND 39). REG. 11-28-2000.
- 2,408,028. RED BUD. INT. CL. 41. (U.S. CLS. 100, 101 AND 107). REG. 11-28-2000.
- 2,408,358. BERNINA. INT. CLS. 7 AND 9. (U.S. CLS. 13, 19, 21, 23, 26, 31, 34, 35, 36 AND 38). REG. 11-28-2000.
- 2,408,451. BACB. INT. CL. 42. (U.S. CLS. 100 AND 101). REG. 11-28-2000.
- 2,408,460. COLGATE TOTAL AND DESIGN. INT. CL. 3. (U.S. CLS. 1, 4, 6, 50, 51 AND 52). REG. 11-28-2000.
- 2,410,134. DELUSIONAL FILMS. INT. CL. 41. (U.S. CLS. 100, 101 AND 107). REG. 12-5-2000.
- 2,413,400. IM IMAGEMASTER TECHNOLOGY AND DESIGN. INT. CL. 9. (U.S. CLS. 21, 23, 26, 36 AND 38). REG. 12-19-2000.
- 2,414,309. DUREX AND DESIGN. INT. CLS. 5 AND 10. (U.S. CLS. 6, 18, 26, 39, 44, 46, 51 AND 52). REG. 12-19-2000.
- 2,415,349. DONARIUS. INT. CL. 9. (U.S. CLS. 21, 23, 26, 36 AND 38). REG. 12-26-2000.
- 2,416,672. CHIMBOTE. INT. CL. 29. (U.S. CL. 46). REG. 12-26-2000.
- 2,416,746. GLOBAL COMPUTER SUPPLIES. INT. CL. 35. (U.S. CLS. 100, 101 AND 102). REG. 1-2-2001.
- 2,417,336. THAI ORCHID RESTAURANT TO AND DESIGN. INT. CL. 42. (U.S. CLS. 100 AND 101). REG. 1-2-2001.
- 2,418,380. WHATAGUY. INT. CL. 42. (U.S. CLS. 100 AND 101). REG. 1-2-2001.
- 2,418,394. A AND DESIGN. INT. CL. 42. (U.S. CLS. 100 AND 101). REG. 1-2-2001.
- 2,418,489. GLOBAL AND DESIGN. INT. CL. 42. (U.S. CL. 101). REG. 1-9-2001.
- 2,418,631. FROM THE SOURCE TO THE PLATE. INT. CL. 29. (U.S. CL. 46). REG. 1-9-2001.
- 2,418,844. FROZEN ROTORS CRYOGENICALLY TREATED BRAKEDISCS AND DESIGN. INT. CL. 6. (U.S. CLS. 2, 12, 13, 14, 23, 25 AND 50). REG. 1-9-2001.
- 2,418,864. CD 2000. INT. CL. 6. (U.S. CLS. 2, 12, 13, 14, 23, 25 AND 50). REG. 1-9-2001.
- 2,419,067. APLUS EXPRESS AND DESIGN. INT. CL. 35. (U.S. CLS. 100, 101 AND 102). REG. 1-9-2001.
- 2,419,073. A PLUS EXPRESS AND DESIGN. INT. CL. 35. (U.S. CLS. 100, 101 AND 102). REG. 1-9-2001.
- 2,419,796. D8 (STYLIZED). INT. CL. 9. (U.S. CLS. 21, 23, 26, 36 AND 38). REG. 1-9-2001.
- 2,419,953. FINELINE. INT. CL. 10. (U.S. CLS. 26, 39 AND 44). REG. 1-9-2001.
- 2,420,623. CMI (STYLIZED). INT. CLS. 9 AND 17. (U.S. CLS. 1, 5, 12, 13, 21, 23, 26, 35, 36, 38 AND 50). REG. 1-16-2001.
- 2,420,672. NICOLE BY O-P-I. INT. CL. 3. (U.S. CLS. 1, 4, 6, 50, 51 AND 52). REG. 1-16-2001.
- 2,420,713. MANY HANDS MEDIA AND DESIGN. INT. CL. 16. (U.S. CLS. 2, 5, 22, 23, 29, 37, 38 AND 50). REG. 1-16-2001.
- 2,421,137. DINEL. INT. CL. 9. (U.S. CLS. 21, 23, 26, 36 AND 38). REG. 1-16-2001.
- 2,421,734. GOD AND DESIGN. INT. CLS. 16 AND 25. (U.S. CLS. 2, 5, 22, 23, 29, 37, 38, 39 AND 50). REG. 1-16-2001.
- 2,422,156. BUNK BUDDY. INT. CL. 21. (U.S. CLS. 2, 13, 23, 29, 30, 33, 40 AND 50). REG. 1-16-2001.
- 2,422,608. AD BLOCKS. INT. CL. 9. (U.S. CLS. 21, 23, 26, 36 AND 38). REG. 1-23-2001.
- 2,422,746. S AND DESIGN. INT. CLS. 8, 9, 20 AND 21. (U.S. CLS. 2, 13, 21, 22, 23, 25, 26, 28, 29, 30, 32, 33, 36, 38, 40, 44 AND 50). REG. 1-23-2001.
- 2,422,900. 24-7 AUTOPARTS.COM AND DESIGN. INT. CL. 35. (U.S. CLS. 100, 101 AND 102). REG. 1-23-2001.
- 2,423,485. NB&DC NATIONAL BUSINESS & DISABILITY COUNCIL COMMITTED TO DIVERSITY AND DESIGN. INT. CLS. 16 AND 35. (U.S. CLS. 2, 5, 22, 23, 29, 37, 38, 50, 100, 101 AND 102). REG. 1-23-2001.
- 2,423,664. VHDM. INT. CL. 9. (U.S. CLS. 21, 23, 26, 36 AND 38). REG. 1-23-2001.
- 2,423,906. TOP BANANA. INT. CL. 28. (U.S. CLS. 22, 23, 38 AND 50). REG. 1-23-2001.
- 2,424,108. FORGEMASTER. INT. CL. 11. (U.S. CLS. 13, 21, 23, 31 AND 34). REG. 1-23-2001.
- 2,424,560. SUPERS AND DESIGN. INT. CL. 3. (U.S. CLS. 1, 4, 6, 50, 51 AND 52). REG. 1-30-2001.

- 2,424,581. TRITON BOATS BY EARL BENTZ AND DESIGN. INT. CL. 12. (U.S. CLS. 19, 21, 23, 31, 35 AND 44). REG. 1-30-2001.
- 2,424,732. WOOLWICH DAIRY. INT. CL. 29. (U.S. CL. 46). REG. 1-30-2001.
- 2,425,060. SUN RINGLE. INT. CL. 12. (U.S. CLS. 19, 21, 23, 31, 35 AND 44). REG. 1-30-2001.
- 2,425,193. MISCELLANEOUS DESIGN. INT. CL. 41. (U.S. CLS. 100, 101 AND 107). REG. 1-30-2001.
- 2,425,337. FARREY'S. INT. CL. 35. (U.S. CLS. 100, 101 AND 102). REG. 1-30-2001.
- 2,425,339. FARREY'S LIGHTING & BATH. INT. CL. 35. (U.S. CLS. 100, 101 AND 102). REG. 1-30-2001.
- 2,425,635. READING PARTNERS THE BUDDY TUTORING PROGRAM FROM BOYS' LIFE. INT. CL. 41. (U.S. CLS. 100, 101 AND 107). REG. 1-30-2001.
- 2,426,163. RESPONSYS. INT. CL. 42. (U.S. CLS. 100 AND 101). REG. 2-6-2001.
- 2,426,286. BARNEBIRKIE. INT. CL. 41. (U.S. CLS. 100, 101 AND 107). REG. 2-6-2001.
- 2,426,378. SAS AND DESIGN. INT. CL. 25. (U.S. CLS. 22 AND 39). REG. 2-6-2001.
- 2,426,392. NATIONAL MUSIC PUBLISHERS' ASSOCIATION. INT. CL. 16. (U.S. CLS. 2, 5, 22, 23, 29, 37, 38 AND 50). REG. 2-6-2001.
- 2,426,526. DURACO. INT. CL. 17. (U.S. CLS. 1, 5, 12, 13, 35 AND 50). REG. 2-6-2001.
- 2,426,645. MISCELLANEOUS DESIGN. INT. CL. 38. (U.S. CLS. 100, 101 AND 104). REG. 2-6-2001.
- 2,426,649. ASK DR. MATH. INT. CLS. 41 AND 42. (U.S. CLS. 100, 101 AND 107). REG. 2-6-2001.
- 2,426,650. T2T. INT. CLS. 41 AND 42. (U.S. CLS. 100, 101 AND 107). REG. 2-6-2001.
- 2,426,712. MISCELLANEOUS DESIGN. INT. CL. 42. (U.S. CLS. 100 AND 101). REG. 2-6-2001.
- 2,426,716. ADMIRAL'S COVE AND DESIGN. INT. CL. 41. (U.S. CLS. 100, 101 AND 107). REG. 2-6-2001.
- 2,426,973. DAVID'S BRIDAL. INT. CL. 35. (U.S. CLS. 100, 101 AND 102). REG. 2-6-2001.
- 2,427,078. FIRST ALERT. INT. CL. 9. (U.S. CLS. 21, 23, 26, 36 AND 38). REG. 2-6-2001.
- 2,427,100. BADGER AND DESIGN. INT. CL. 9. (U.S. CLS. 21, 23, 26, 36 AND 38). REG. 2-6-2001.
- 2,427,338. XECTR. INT. CL. 5. (U.S. CLS. 6, 18, 44, 46, 51 AND 52). REG. 2-6-2001.
- 2,427,392. COMFORT RIDE. INT. CL. 12. (U.S. CLS. 19, 21, 23, 31, 35 AND 44). REG. 2-6-2001.
- 2,427,460. ADVIA CENTAUR. INT. CLS. 5 AND 10. (U.S. CLS. 6, 18, 26, 39, 44, 46, 51 AND 52). REG. 2-6-2001.
- 2,427,815. EIE AND DESIGN. INT. CLS. 9, 37 AND 42. (U.S. CLS. 21, 23, 26, 36, 38, 100, 101, 103 AND 106). REG. 2-13-2001.
- 2,427,989. BMC SOFTWARE. INT. CL. 9. (U.S. CLS. 21, 23, 26, 36 AND 38). REG. 2-13-2001.
- 2,428,135. TRUSTE KIDS PRIVACY STATEMENT AND DESIGN. U.S. CL. B. REG. 2-13-2001.
- 2,428,219. STAY COOL BE STRONG. INT. CL. 14. (U.S. CLS. 2, 27, 28 AND 50). REG. 2-13-2001.
- 2,428,334. LIGHTHAWK. INT. CL. 9. (U.S. CLS. 21, 23, 26, 36 AND 38). REG. 2-13-2001.
- 2,428,363. SMUT & EGGS. INT. CL. 42. (U.S. CLS. 100 AND 101). REG. 2-13-2001.
- 2,428,369. ANXIETY COACH. INT. CL. 42. (U.S. CLS. 100 AND 101). REG. 2-13-2001.
- 2,428,511. WORLD STAGE. INT. CL. 9. (U.S. CLS. 21, 23, 26, 36 AND 38). REG. 2-13-2001.
- 2,428,553. VISTABOOKS. INT. CL. 16. (U.S. CLS. 2, 5, 22, 23, 29, 37, 38 AND 50). REG. 2-13-2001.
- 2,428,589. SNAP3. INT. CL. 9. (U.S. CLS. 21, 23, 26, 36 AND 38). REG. 2-13-2001.
- 2,428,632. SV AND DESIGN. INT. CL. 33. (U.S. CLS. 47 AND 49). REG. 2-13-2001.
- 2,428,649. LITE TOUCH. INT. CL. 20. (U.S. CLS. 2, 13, 22, 25, 32 AND 50). REG. 2-13-2001.
- 2,428,710. YELIYA AND DESIGN. INT. CL. 25. (U.S. CLS. 22 AND 39). REG. 2-13-2001.
- 2,428,846. BURGER KING AND DESIGN. INT. CL. 42. (U.S. CLS. 100 AND 101). REG. 2-13-2001.
- 2,428,851. DAD'S GOURMET BLEND. INT. CL. 31. (U.S. CLS. 1 AND 46). REG. 2-13-2001.
- 2,428,899. PIT DROIDS. INT. CL. 9. (U.S. CLS. 21, 23, 26, 36 AND 38). REG. 2-13-2001.
- 2,428,905. MISCELLANEOUS DESIGN. INT. CL. 25. (U.S. CLS. 22 AND 39). REG. 2-13-2001.
- 2,428,946. M.T.B MEANT TO BE AND DESIGN. INT. CL. 25. (U.S. CLS. 22 AND 39). REG. 2-13-2001.
- 2,428,994. BONSER. INT. CL. 25. (U.S. CLS. 22 AND 39). REG. 2-13-2001.
- 2,429,033. PRODUCTION PARTNERS INC.. INT. CL. 41. (U.S. CLS. 100, 101 AND 107). REG. 2-20-2001.
- 2,429,047. SYSTRANET. INT. CLS. 9 AND 38. (U.S. CLS. 21, 23, 26, 36, 38, 100, 101 AND 104). REG. 2-20-2001.
- 2,429,066. SPINK. INT. CL. 14. (U.S. CLS. 2, 27, 28 AND 50). REG. 2-20-2001.
- 2,429,079. CLASSICALF. INT. CL. 31. (U.S. CLS. 1 AND 46). REG. 2-20-2001.
- 2,429,102. MARTHA'S SCRAPBOOK. INT. CL. 42. (U.S. CLS. 100 AND 101). REG. 2-20-2001.
- 2,429,197. NATIONAL MUSEUM OF WOMEN IN THE ARTS. U.S. CL. 200. REG. 2-20-2001.
- 2,429,211. ENVIRONMENTAL QUALITY MANAGEMENT, INC.. INT. CLS. 37 AND 42. (U.S. CLS. 100, 101, 103 AND 106). REG. 2-20-2001.
- 2,429,242. DYNAMIC HEART RATE CONTROL AND DESIGN. INT. CL. 28. (U.S. CLS. 22, 23, 38 AND 50). REG. 2-20-2001.
- 2,429,271. GOTTA HAVE IT!. INT. CL. 35. (U.S. CLS. 100, 101 AND 102). REG. 2-20-2001.
- 2,429,293. MOISTURE PLUS. INT. CL. 11. (U.S. CLS. 13, 21, 23, 31 AND 34). REG. 2-20-2001.
- 2,429,343. VERIFY-1. INT. CL. 35. (U.S. CLS. 100, 101 AND 102). REG. 2-20-2001.
- 2,429,384. ROCKIN' RASPBERRY. INT. CL. 29. (U.S. CL. 46). REG. 2-20-2001.
- 2,429,386. COLORGENE. INT. CLS. 1 AND 5. (U.S. CLS. 1, 5, 6, 10, 18, 26, 44, 46, 51 AND 52). REG. 2-20-2001.
- 2,429,400. CHRISTIES' MAPLE FARM. INT. CL. 30. (U.S. CL. 46). REG. 2-20-2001.
- 2,429,420. FEEDER MANAGEMENT RELAY. INT. CL. 9. (U.S. CLS. 21, 23, 26, 36 AND 38). REG. 2-20-2001.
- 2,429,468. SCR. INT. CL. 36. (U.S. CLS. 100, 101 AND 102). REG. 2-20-2001.
- 2,429,475. THE SPIRIT OF LEARNING. INT. CLS. 16 AND 41. (U.S. CLS. 2, 5, 22, 23, 29, 37, 38, 50, 100, 101 AND 107). REG. 2-20-2001.
- 2,429,476. THE WAY OF EASE. INT. CLS. 16 AND 41. (U.S. CLS. 2, 5, 22, 23, 29, 37, 38, 50, 100, 101 AND 107). REG. 2-20-2001.
- 2,429,487. VETMEDIN. INT. CL. 5. (U.S. CLS. 6, 18, 44, 46, 51 AND 52). REG. 2-20-2001.
- 2,429,524. AIRDD (STYLIZED). INT. CL. 20. (U.S. CLS. 2, 13, 22, 25, 32 AND 50). REG. 2-20-2001.
- 2,429,568. GOLF MAGAZINE. INT. CL. 41. (U.S. CLS. 100, 101 AND 107). REG. 2-20-2001.
- 2,429,579. CRACKER GIRL. INT. CL. 30. (U.S. CL. 46). REG. 2-20-2001.
- 2,429,580. CRACKER GIRL AND DESIGN. INT. CL. 30. (U.S. CL. 46). REG. 2-20-2001.
- 2,429,582. CRACKER BOY. INT. CL. 30. (U.S. CL. 46). REG. 2-20-2001.
- 2,429,599. Q T AND DESIGN. INT. CL. 3. (U.S. CLS. 1, 4, 6, 50, 51 AND 52). REG. 2-20-2001.
- 2,429,619. AUTODEBLUR. INT. CL. 9. (U.S. CLS. 21, 23, 26, 36 AND 38). REG. 2-20-2001.
- 2,429,654. GATEPASS. INT. CL. 9. (U.S. CLS. 21, 23, 26, 36 AND 38). REG. 2-20-2001.
- 2,429,655. GATEPASS AND DESIGN. INT. CL. 9. (U.S. CLS. 21, 23, 26, 36 AND 38). REG. 2-20-2001.
- 2,429,701. REFERENCE BILLS. INT. CL. 36. (U.S. CLS. 100, 101 AND 102). REG. 2-20-2001.
- 2,429,746. ROCKBROOK VILLAGE. INT. CL. 36. (U.S. CLS. 100, 101 AND 102). REG. 2-20-2001.
- 2,429,777. LEARN TO LEAD (STYLIZED). INT. CL. 16. (U.S. CLS. 2, 5, 22, 23, 29, 37, 38 AND 50). REG. 2-20-2001.
- 2,429,806. Z-RACK. INT. CL. 6. (U.S. CLS. 2, 12, 13, 14, 23, 25 AND 50). REG. 2-20-2001.
- 2,429,882. EURO CAFE (STYLIZED). INT. CL. 42. (U.S. CLS. 100 AND 101). REG. 2-20-2001.
- 2,429,898. THERMOCAL. INT. CL. 5. (U.S. CLS. 6, 18, 44, 46, 51 AND 52). REG. 2-20-2001.
- 2,429,988. NEWSKIES. INT. CL. 38. (U.S. CLS. 100, 101 AND 104). REG. 2-20-2001.
- 2,429,998. TOGO'S GREAT SANDWICHES AND DESIGN. INT. CL. 42 ONLY. (U.S. CLS. 100 AND 101). REG. 2-20-2001.
- 2,429,999. TOGO'S GREAT SANDWICHES AND DESIGN. INT. CL. 42 ONLY. (U.S. CLS. 100 AND 101). REG. 2-20-2001.

- 2,430,006. WRESTLE THE WORLD. INT. CL. 41. (U.S. CLS. 100, 101 AND 107). REG. 2-20-2001.
- 2,430,019. SUGARLOAFCRAFTS.COM. INT. CL. 41. (U.S. CLS. 100, 101 AND 107). REG. 2-20-2001.
- 2,430,066. EURO STAR. INT. CL. 20. (U.S. CLS. 2, 13, 22, 25, 32 AND 50). REG. 2-20-2001.
- 2,430,067. STARLIGHT DUVET INSERT. INT. CL. 24. (U.S. CLS. 42 AND 50). REG. 2-20-2001.
- 2,430,068. TROPICAL STAR. INT. CL. 24. (U.S. CLS. 42 AND 50). REG. 2-20-2001.
- 2,430,075. YOUR FUTURE PAYCHECK. INT. CL. 41. (U.S. CLS. 100, 101 AND 107). REG. 2-20-2001.
- 2,430,161. NETTOUCH. INT. CL. 9. (U.S. CLS. 21, 23, 26, 36 AND 38). REG. 2-20-2001.
- 2,430,171. SUCK. INT. CL. 38. (U.S. CLS. 100, 101 AND 104). REG. 2-20-2001.
- 2,430,213. DIRECT REWARDS. INT. CL. 36. (U.S. CLS. 100, 101 AND 102). REG. 2-20-2001.
- 2,430,280. DYNA-DRIVE. INT. CL. 8. (U.S. CLS. 23, 28 AND 44). REG. 2-20-2001.
- 2,430,282. MISCELLANEOUS DESIGN. INT. CL. 41. (U.S. CLS. 100, 101 AND 107). REG. 2-20-2001.
- 2,430,301. DRUTHERS ORANGE COW. INT. CL. 32. (U.S. CLS. 45, 46 AND 48). REG. 2-20-2001.
- 2,430,328. HUMMER JET JR.. INT. CL. 7. (U.S. CLS. 13, 19, 21, 23, 31, 34 AND 35). REG. 2-20-2001.
- 2,430,334. HUMMER JET JR. AND DESIGN. INT. CL. 7. (U.S. CLS. 13, 19, 21, 23, 31, 34 AND 35). REG. 2-20-2001.
- 2,430,349. THE POWER TO COMBINE. INT. CLS. 35 AND 42. (U.S. CLS. 100, 101 AND 102). REG. 2-20-2001.
- 2,430,383. THE WESTERN GROUP. INT. CLS. 6, 17 AND 35. (U.S. CLS. 1, 2, 5, 12, 13, 14, 23, 25, 35, 50, 100, 101 AND 102). REG. 2-20-2001.
- 2,430,398. L CONNECTION. INT. CL. 9. (U.S. CLS. 21, 23, 26, 36 AND 38). REG. 2-20-2001.
- 2,430,403. GRAVISAND. INT. CL. 11. (U.S. CLS. 13, 21, 23, 31 AND 34). REG. 2-20-2001.
- 2,430,458. I-ODOGY. INT. CL. 42. (U.S. CLS. 100 AND 101). REG. 2-20-2001.
- 2,430,500. DATATREASURY. INT. CLS. 9 AND 42. (U.S. CLS. 21, 23, 26, 36, 38, 100 AND 101). REG. 2-20-2001.
- 2,430,553. NUMBER ONE PUTTER IN GOLF. INT. CL. 28. (U.S. CLS. 22, 23, 38 AND 50). REG. 2-20-2001.
- 2,430,590. SERIOUS ACTION. INT. CL. 5. (U.S. CLS. 6, 18, 44, 46, 51 AND 52). REG. 2-27-2001.
- 2,430,605. MISCELLANEOUS DESIGN. INT. CL. 36. (U.S. CLS. 100, 101 AND 102). REG. 2-27-2001.
- 2,430,659. DERMA GENESIS. INT. CL. 3. (U.S. CLS. 1, 4, 6, 50, 51 AND 52). REG. 2-27-2001.
- 2,430,662. MISCELLANEOUS DESIGN. INT. CL. 28. (U.S. CLS. 22, 23, 38 AND 50). REG. 2-27-2001.
- 2,430,663. MISCELLANEOUS DESIGN. INT. CL. 28. (U.S. CLS. 22, 23, 38 AND 50). REG. 2-27-2001.
- 2,430,682. DATUM AND DESIGN. INT. CLS. 16 AND 20. (U.S. CLS. 2, 5, 13, 22, 23, 25, 29, 32, 37, 38 AND 50). REG. 2-27-2001.
- 2,430,702. DURO-MED. INT. CLS. 5, 8, 10, 12, 20 AND 21. (U.S. CLS. 2, 6, 13, 18, 19, 21, 22, 23, 25, 26, 28, 29, 30, 31, 32, 33, 35, 39, 40, 44, 46, 50, 51 AND 52). REG. 2-27-2001.
- 2,430,722. PROFESSIONAL TRAFFIC OPERATIONS ENGINEER TRANSPORTATION PROFESSIONAL CERTIFICATION BOARD, INC. AND DESIGN. U.S. CL. B. REG. 2-27-2001.
- 2,430,729. KALEIDA HEALTH AND DESIGN. INT. CL. 42. (U.S. CLS. 100 AND 101). REG. 2-27-2001.
- 2,430,756. TS (STYLIZED). INT. CL. 14 ONLY. (U.S. CLS. 2, 27, 28 AND 50). REG. 2-27-2001.
- 2,430,765. MYSTIC AQUARIUM AND DESIGN. INT. CL. 41. (U.S. CLS. 100, 101 AND 107). REG. 2-27-2001.
- 2,430,783. ALT-N TECHNOLOGIES. INT. CL. 9. (U.S. CLS. 21, 23, 26, 36 AND 38). REG. 2-27-2001.
- 2,430,787. BULAGGI. INT. CL. 18. (U.S. CLS. 1, 2, 3, 22 AND 41). REG. 2-27-2001.
- 2,430,856. MISCELLANEOUS DESIGN. INT. CLS. 18 AND 25. (U.S. CLS. 1, 2, 3, 22, 39 AND 41). REG. 2-27-2001.
- 2,430,878. MISCELLANEOUS DESIGN. INT. CLS. 3 AND 5. (U.S. CLS. 1, 4, 6, 18, 44, 46, 50, 51 AND 52). REG. 2-27-2001.
- 2,430,881. CHAMBERLIN'S. INT. CLS. 35 AND 42. (U.S. CLS. 100, 101 AND 102). REG. 2-27-2001.
- 2,430,890. DYNOLAB. INT. CL. 9. (U.S. CLS. 21, 23, 26, 36 AND 38). REG. 2-27-2001.
- 2,430,893. INFRALIGHT (STYLIZED). INT. CL. 11. (U.S. CLS. 13, 21, 23, 31 AND 34). REG. 2-27-2001.
- 2,430,922. NKN AND DESIGN. INT. CL. 12. (U.S. CLS. 19, 21, 23, 31, 35 AND 44). REG. 2-27-2001.
- 2,430,940. RB AND DESIGN. INT. CLS. 6, 9, 12 AND 20. (U.S. CLS. 2, 12, 13, 14, 19, 21, 22, 23, 25, 26, 31, 32, 35, 36, 38, 44 AND 50). REG. 2-27-2001.
- 2,430,960. ELANCO. INT. CL. 42. (U.S. CLS. 100 AND 101). REG. 2-27-2001.
- 2,430,963. WOOD IRON WOOD FINISHES THE SOLUTIONS FOR WOOD!. INT. CLS. 2 AND 3. (U.S. CLS. 1, 4, 6, 11, 16, 50, 51 AND 52). REG. 2-27-2001.
- 2,431,010. WEBMAGIC. INT. CLS. 35, 37, 38, 41 AND 42. (U.S. CLS. 100, 101, 102, 103, 104, 106 AND 107). REG. 2-27-2001.
- 2,431,012. CROSSTOWN SHOOTOUT. INT. CL. 41. (U.S. CLS. 100, 101 AND 107). REG. 2-27-2001.
- 2,431,013. ALPHA PROFESSIONAL TOOLS AND DESIGN. INT. CL. 7. (U.S. CLS. 13, 19, 21, 23, 31, 34 AND 35). REG. 2-27-2001.
- 2,431,029. BREAKAWAYS. INT. CL. 36. (U.S. CLS. 100, 101 AND 102). REG. 2-27-2001.
- 2,431,031. CULEX. INT. CL. 9. (U.S. CLS. 21, 23, 26, 36 AND 38). REG. 2-27-2001.
- 2,431,047. THRASHER. INT. CL. 14. (U.S. CLS. 2, 27, 28 AND 50). REG. 2-27-2001.
- 2,431,081. K-LAK CORPORATION CREDIT REPORTING COLLECTIONS CONSULTING (STYLIZED). INT. CL. 35. (U.S. CLS. 100, 101 AND 102). REG. 2-27-2001.
- 2,431,087. INCOME BUILDERS INTERNATIONAL. INT. CL. 41. (U.S. CLS. 100, 101 AND 107). REG. 2-27-2001.
- 2,431,133. MISCELLANEOUS DESIGN. INT. CLS. 41 AND 42. (U.S. CLS. 100, 101 AND 107). REG. 2-27-2001.
- 2,431,156. DURA GRADE. INT. CL. 7. (U.S. CLS. 13, 19, 21, 23, 31, 34 AND 35). REG. 2-27-2001.
- 2,431,169. STOP SURFING. GO CRUISING. (STYLIZED). INT. CLS. 39 AND 42. (U.S. CLS. 100, 101 AND 105). REG. 2-27-2001.
- 2,431,243. MISCELLANEOUS DESIGN. INT. CLS. 16, 24, 25 AND 42. (U.S. CLS. 2, 5, 22, 23, 29, 37, 38, 39, 42, 50, 100 AND 101). REG. 2-27-2001.
- 2,431,278. THE ART OF WHERE. INT. CL. 42. (U.S. CLS. 100 AND 101). REG. 2-27-2001.
- 2,431,314. NAVSEA NAVAL SEA SYSTEMS COMMAND AND DESIGN. INT. CLS. 16 AND 42. (U.S. CLS. 2, 5, 22, 23, 29, 37, 38, 50, 100 AND 101). REG. 2-27-2001.
- 2,431,362. DYNAMETRIC. INT. CL. 9. (U.S. CLS. 21, 23, 26, 36 AND 38). REG. 2-27-2001.
- 2,431,411. HERTZ. INT. CL. 35. (U.S. CLS. 100, 101 AND 102). REG. 2-27-2001.
- 2,431,420. CASUAL GOURMET AND DESIGN. INT. CL. 29. (U.S. CL. 46). REG. 2-27-2001.
- 2,431,448. GEORGE'S. INT. CL. 5. (U.S. CLS. 6, 18, 44, 46, 51 AND 52). REG. 2-27-2001.
- 2,431,459. DYMEDIX. INT. CL. 10. (U.S. CLS. 26, 39 AND 44). REG. 2-27-2001.
- 2,431,505. XYTEX. INT. CL. 42. (U.S. CLS. 100 AND 101). REG. 2-27-2001.
- 2,431,525. MISCELLANEOUS DESIGN. INT. CL. 29. (U.S. CL. 46). REG. 2-27-2001.
- 2,431,526. PIXAMI. INT. CL. 9. (U.S. CLS. 21, 23, 26, 36 AND 38). REG. 2-27-2001.
- 2,431,537. GENEROUS GIVING. INT. CL. 41. (U.S. CLS. 100, 101 AND 107). REG. 2-27-2001.
- 2,431,564. ENZO. INT. CL. 12. (U.S. CLS. 19, 21, 23, 31, 35 AND 44). REG. 2-27-2001.
- 2,431,581. IT GOVERNANCE INSTITUTE AND DESIGN. INT. CL. 16. (U.S. CLS. 2, 5, 22, 23, 29, 37, 38 AND 50). REG. 2-27-2001.
- 2,431,583. GETTING THINGS DONE. INT. CL. 41. (U.S. CLS. 100, 101 AND 107). REG. 2-27-2001.
- 2,431,587. HOMESTEADERS LIFE. INT. CL. 36. (U.S. CLS. 100, 101 AND 102). REG. 2-27-2001.
- 2,431,619. TRIUMPH. INT. CL. 16. (U.S. CLS. 2, 5, 22, 23, 29, 37, 38 AND 50). REG. 2-27-2001.
- 2,431,621. SAMBUCA DI ANGELA. INT. CL. 33. (U.S. CLS. 47 AND 49). REG. 2-27-2001.
- 2,431,662. BISOU BISOU. INT. CL. 25. (U.S. CLS. 22 AND 39). REG. 2-27-2001.

- 2,431,669. TALENTMATCH. INT. CL. 35. (U.S. CLS. 100, 101 AND 102). REG. 2-27-2001.
- 2,431,685. RICATONI'S. INT. CL. 42. (U.S. CLS. 100 AND 101). REG. 2-27-2001.
- 2,431,723. EXPANDER. INT. CL. 9. (U.S. CLS. 21, 23, 26, 36 AND 38). REG. 2-27-2001.
- 2,431,836. K.BOXING AND DESIGN. INT. CL. 25. (U.S. CLS. 22 AND 39). REG. 2-27-2001.
- 2,431,871. THE FLEXIBLE SOLUTIONS COMPANY. INT. CL. 35. (U.S. CLS. 100, 101 AND 102). REG. 2-27-2001.
- 2,431,889. GN NETCOM (STYLIZED). INT. CL. 9. (U.S. CLS. 21, 23, 26, 36 AND 38). REG. 2-27-2001.
- 2,431,901. ELORAE. INT. CL. 9. (U.S. CLS. 21, 23, 26, 36 AND 38). REG. 2-27-2001.
- 2,431,908. OMD. INT. CL. 35. (U.S. CLS. 100, 101 AND 102). REG. 2-27-2001.
- 2,431,928. LANC. INT. CL. 9. (U.S. CLS. 21, 23, 26, 36 AND 38). REG. 2-27-2001.
- 2,431,952. AIR LIQUIDE. INT. CL. 42. (U.S. CLS. 100 AND 101). REG. 2-27-2001.
- 2,431,953. HEALTHCARE MANAGEMENT UNIVERSITY. INT. CL. 41. (U.S. CLS. 100, 101 AND 107). REG. 2-27-2001.
- 2,431,969. FES. INT. CL. 36. (U.S. CLS. 100, 101 AND 102). REG. 2-27-2001.
- 2,431,992. BLINKERSTOP. INT. CL. 9. (U.S. CLS. 21, 23, 26, 36 AND 38). REG. 2-27-2001.
- 2,432,036. EZ-CHOICE. INT. CL. 11. (U.S. CLS. 13, 21, 23, 31 AND 34). REG. 2-27-2001.
- 2,432,112. MEMES. INT. CL. 35. (U.S. CLS. 100, 101 AND 102). REG. 2-27-2001.
- 2,432,118. BCPC (STYLIZED). INT. CL. 9. (U.S. CLS. 21, 23, 26, 36 AND 38). REG. 2-27-2001.
- 2,432,154. RENAISSANCE REFLECTION. INT. CL. 31. (U.S. CLS. 1 AND 46). REG. 2-27-2001.
- 2,432,179. MICROPLANAR. INT. CL. 1. (U.S. CLS. 1, 5, 6, 10, 26 AND 46). REG. 2-27-2001.
- 2,432,192. VEUVE CLICQUOT AND DESIGN. INT. CL. 33. (U.S. CLS. 47 AND 49). REG. 2-27-2001.
- 2,432,198. SIMONTON IMPRESSIONS. INT. CL. 19. (U.S. CLS. 1, 12, 33 AND 50). REG. 2-27-2001.
- 2,432,214. SEAT MATE. INT. CL. 20. (U.S. CLS. 2, 13, 22, 25, 32 AND 50). REG. 2-27-2001.
- 2,432,226. DAISY CHRISOM. INT. CL. 19. (U.S. CLS. 1, 12, 33 AND 50). REG. 2-27-2001.
- 2,432,273. TRACER METRO. INT. CL. 10. (U.S. CLS. 26, 39 AND 44). REG. 2-27-2001.
- 2,432,274. CAESAR. INT. CL. 10. (U.S. CLS. 26, 39 AND 44). REG. 2-27-2001.
- 2,432,325. MISCELLANEOUS DESIGN. INT. CL. 28. (U.S. CLS. 22, 23, 38 AND 50). REG. 2-27-2001.
- 2,432,377. HENDRICK'S. INT. CL. 33. (U.S. CLS. 47 AND 49). REG. 2-27-2001.
- 2,432,458. CAPTAIN FEATHERSWORD. INT. CL. 41. (U.S. CLS. 100, 101 AND 107). REG. 3-6-2001.
- 2,432,494. SPITFIRE. INT. CL. 28. (U.S. CLS. 22, 23, 38 AND 50). REG. 3-6-2001.
- 2,432,496. CAN-DO. INT. CLS. 9 AND 10. (U.S. CLS. 21, 23, 26, 36, 38, 39 AND 44). REG. 3-6-2001.
- 2,432,519. ECI. INT. CL. 9. (U.S. CLS. 21, 23, 26, 36 AND 38). REG. 3-6-2001.
- 2,432,528. UNIFIX. INT. CL. 19. (U.S. CLS. 1, 12, 33 AND 50). REG. 3-6-2001.
- 2,432,756. STACKERS. INT. CL. 29. (U.S. CL. 46). REG. 3-6-2001.
- 2,432,816. REFRIGERATED & FROZEN FOODS. INT. CLS. 16 AND 35. (U.S. CLS. 2, 5, 22, 23, 29, 37, 38, 50, 100, 101 AND 102). REG. 3-6-2001.
- 2,432,819. BOUNDARY WATERS. INT. CL. 9. (U.S. CLS. 21, 23, 26, 36 AND 38). REG. 3-6-2001.
- 2,432,835. APYMAG. INT. CL. 1. (U.S. CLS. 1, 5, 6, 10, 26 AND 46). REG. 3-6-2001.
- 2,432,845. PERMACORE. INT. CL. 19. (U.S. CLS. 1, 12, 33 AND 50). REG. 3-6-2001.
- 2,432,893. SHORTHORN. INT. CL. 15. (U.S. CLS. 2, 21 AND 36). REG. 3-6-2001.
- 2,432,904. FIRST DEFENSE. INT. CL. 5. (U.S. CLS. 6, 18, 44, 46, 51 AND 52). REG. 3-6-2001.
- 2,432,933. PRO COOL. INT. CL. 9. (U.S. CLS. 21, 23, 26, 36 AND 38). REG. 3-6-2001.
- 2,432,934. TWO COOL. INT. CL. 9. (U.S. CLS. 21, 23, 26, 36 AND 38). REG. 3-6-2001.
- 2,433,005. ROUND ROCK EXPRESS AND DESIGN. INT. CLS. 14, 16, 25 AND 28. (U.S. CLS. 2, 5, 22, 23, 27, 28, 29, 37, 38, 39 AND 50). REG. 3-6-2001.
- 2,433,035. EPE. INT. CL. 39. (U.S. CLS. 100 AND 105). REG. 3-6-2001.
- 2,433,065. BACK COUNTRY. INT. CL. 16. (U.S. CLS. 2, 5, 22, 23, 29, 37, 38 AND 50). REG. 3-6-2001.
- 2,433,066. GUITAR.COM. INT. CL. 25. (U.S. CLS. 22 AND 39). REG. 3-6-2001.
- 2,433,090. HSI BANKING. INT. CL. 36. (U.S. CLS. 100, 101 AND 102). REG. 3-6-2001.
- 2,433,091. SCR PROGRAM. INT. CL. 36. (U.S. CLS. 100, 101 AND 102). REG. 3-6-2001.
- 2,433,137. MISCELLANEOUS DESIGN. INT. CLS. 35 AND 42. (U.S. CLS. 100, 101 AND 102). REG. 3-6-2001.
- 2,433,164. PAINT QUALITY INSTITUTE. INT. CLS. 16 AND 41. (U.S. CLS. 2, 5, 22, 23, 29, 37, 38, 50, 100, 101 AND 107). REG. 3-6-2001.
- 2,433,264. X10. INT. CL. 9. (U.S. CLS. 21, 23, 26, 36 AND 38). REG. 3-6-2001.
- 2,433,273. 5.1 SURROUND AND DESIGN. INT. CL. 9. (U.S. CLS. 21, 23, 26, 36 AND 38). REG. 3-6-2001.
- 2,433,313. ITALIAN STREET PAINTING FESTIVAL AND DESIGN. INT. CL. 41. (U.S. CLS. 100, 101 AND 107). REG. 3-6-2001.
- 2,433,361. DELUSIONAL FILMS AND DESIGN. INT. CL. 41. (U.S. CLS. 100, 101 AND 107). REG. 3-6-2001.
- 2,433,538. COOLSTOCK. INT. CL. 42. (U.S. CLS. 100 AND 101). REG. 3-6-2001.
- 2,433,740. SHINY SHEET. INT. CL. 42. (U.S. CLS. 100 AND 101). REG. 3-6-2001.
- 2,433,764. COMFORT ZONE. INT. CL. 1. (U.S. CLS. 1, 5, 6, 10, 26 AND 46). REG. 3-6-2001.
- 2,433,990. TWIST. INT. CL. 25. (U.S. CLS. 22 AND 39). REG. 3-6-2001.
- 2,433,996. MUDVILLE NINE. INT. CLS. 25, 28 AND 41. (U.S. CLS. 22, 23, 38, 39, 50, 100, 101 AND 107). REG. 3-6-2001.
- 2,434,020. KEVLAR. INT. CL. 9. (U.S. CLS. 21, 23, 26, 36 AND 38). REG. 3-6-2001.
- 2,434,023. ATLANTIC PREFERRED. INT. CL. 18. (U.S. CLS. 1, 2, 3, 22 AND 41). REG. 3-6-2001.
- 2,434,060. STRATUS. INT. CL. 14. (U.S. CLS. 2, 27, 28 AND 50). REG. 3-6-2001.
- 2,434,079. SILVER JONES. INT. CL. 15. (U.S. CLS. 2, 21 AND 36). REG. 3-6-2001.
- 2,434,100. KERASTASE NUTRITIVE. INT. CL. 3. (U.S. CLS. 1, 4, 6, 50, 51 AND 52). REG. 3-6-2001.
- 2,434,101. PRO-BALANCE. INT. CL. 11. (U.S. CLS. 13, 21, 23, 31 AND 34). REG. 3-6-2001.
- 2,434,124. ROCAWEAR. INT. CL. 25. (U.S. CLS. 22 AND 39). REG. 3-6-2001.
- 2,434,153. ASTHMAMENTOR. INT. CL. 10. (U.S. CLS. 26, 39 AND 44). REG. 3-6-2001.
- 2,434,179. HEARTBREAK HOTEL. INT. CL. 21. (U.S. CLS. 2, 13, 23, 29, 30, 33, 40 AND 50). REG. 3-6-2001.
- 2,434,206. TRIDENT. INT. CL. 13. (U.S. CLS. 2 AND 9). REG. 3-6-2001.
- 2,434,344. HEALTH TELEVISION SYSTEM INC.. INT. CL. 9. (U.S. CLS. 21, 23, 26, 36 AND 38). REG. 3-6-2001.
- 2,434,357. BABY SITAR. INT. CL. 15. (U.S. CLS. 2, 21 AND 36). REG. 3-6-2001.
- 2,434,376. THE WORLD'S TOUGHEST BOATS. INT. CL. 12. (U.S. CLS. 19, 21, 23, 31, 35 AND 44). REG. 3-6-2001.
- 2,434,457. A AMERICATEL AND DESIGN. INT. CL. 38. (U.S. CLS. 100, 101 AND 104). REG. 3-13-2001.
- 2,434,556. 360. INT. CL. 21. (U.S. CLS. 2, 13, 23, 29, 30, 33, 40 AND 50). REG. 3-13-2001.
- 2,434,620. TIDE-AIR. INT. CLS. 37 AND 40. (U.S. CLS. 100, 103 AND 106). REG. 3-13-2001.
- 2,434,623. GOLDEN HAWK. INT. CLS. 7 AND 12. (U.S. CLS. 13, 19, 21, 23, 31, 34, 35 AND 44). REG. 3-13-2001.
- 2,434,670. COUNTRY SUN. INT. CL. 29. (U.S. CL. 46). REG. 3-13-2001.
- 2,434,710. BEWARE! AND DESIGN. INT. CL. 25. (U.S. CLS. 22 AND 39). REG. 3-13-2001.
- 2,434,766. MIDLAND ROCKHOUNDS AND DESIGN. INT. CL. 25. (U.S. CLS. 22 AND 39). REG. 3-13-2001.
- 2,434,837. JIM PETERIK AND WORLD STAGE. INT. CL. 9. (U.S. CLS. 21, 23, 26, 36 AND 38). REG. 3-13-2001.
- 2,434,844. COOKING LIGHT. INT. CL. 42. (U.S. CLS. 100 AND 101). REG. 3-13-2001.
- 2,434,951. LEADERSHIP EXCELLENCE AND DESIGN. U.S. CL. 200. REG. 3-13-2001.

- 2,435,077. HERTZ REAL ESTATE SERVICES. INT. CL. 36. (U.S. CLS. 100, 101 AND 102). REG. 3-13-2001.
- 2,435,147. H. UPMANN. INT. CL. 34. (U.S. CLS. 2, 8, 9 AND 17). REG. 3-13-2001.
- 2,435,233. ECCO HEAVY CONSTRUCTION EQUIPMENT RENTALS AND DESIGN. INT. CL. 37. (U.S. CLS. 100, 103 AND 106). REG. 3-13-2001.
- 2,435,251. LOGICBAY. INT. CL. 42. (U.S. CLS. 100 AND 101). REG. 3-13-2001.
- 2,435,280. ECCO A NAME WORTH REPEATING (STYLIZED). INT. CL. 37. (U.S. CLS. 100, 103 AND 106). REG. 3-13-2001.
- 2,435,344. CUREL. INT. CL. 3. (U.S. CLS. 1, 4, 6, 50, 51 AND 52). REG. 3-13-2001.
- 2,435,456. ABSOLUTVODKA. INT. CL. 41. (U.S. CLS. 100, 101 AND 107). REG. 3-13-2001.
- 2,435,633. TOTAL ACCESS. INT. CL. 9. (U.S. CLS. 21, 23, 26, 36 AND 38). REG. 3-13-2001.
- 2,435,708. MEGTEC SPLICE-SET. INT. CL. 16. (U.S. CLS. 2, 5, 22, 23, 29, 37, 38 AND 50). REG. 3-13-2001.
- 2,435,727. TOLKO. INT. CL. 36. (U.S. CLS. 100, 101 AND 102). REG. 3-13-2001.
- 2,435,753. RIU CLASS. INT. CL. 42. (U.S. CLS. 100 AND 101). REG. 3-13-2001.
- 2,435,768. POLY-PERF. INT. CL. 11. (U.S. CLS. 13, 21, 23, 31 AND 34). REG. 3-13-2001.
- 2,435,842. URIKA. INT. CL. 13. (U.S. CLS. 2 AND 9). REG. 3-13-2001.
- 2,435,884. 21ST CENTURY RETIREMENT. INT. CL. 16. (U.S. CLS. 2, 5, 22, 23, 29, 37, 38 AND 50). REG. 3-13-2001.
- 2,435,893. ULTRA-PIG. INT. CL. 7. (U.S. CLS. 13, 19, 21, 23, 31, 34 AND 35). REG. 3-13-2001.
- 2,435,902. LENOX WOODMASTER. INT. CL. 7. (U.S. CLS. 13, 19, 21, 23, 31, 34 AND 35). REG. 3-13-2001.
- 2,435,957. MICRO. INT. CL. 28. (U.S. CLS. 22, 23, 38 AND 50). REG. 3-13-2001.
- 2,436,010. NATIONAL ALL STAR CHEERLEADING CHAMPIONSHIP. INT. CL. 41. (U.S. CLS. 100, 101 AND 107). REG. 3-13-2001.
- 2,436,018. NOTIFYMD. INT. CL. 38. (U.S. CLS. 100, 101 AND 104). REG. 3-13-2001.
- 2,436,038. SELECTION EXCELLENCE. INT. CL. 35. (U.S. CLS. 100, 101 AND 102). REG. 3-13-2001.
- 2,436,055. MISCELLANEOUS DESIGN. INT. CL. 10. (U.S. CLS. 26, 39 AND 44). REG. 3-20-2001.
- 2,436,074. CARDINAL CAPITAL MANAGEMENT, INC.. INT. CL. 36. (U.S. CLS. 100, 101 AND 102). REG. 3-20-2001.
- 2,436,118. WOODSTOCK TEMPLE BELLS. INT. CL. 21. (U.S. CLS. 2, 13, 23, 29, 30, 33, 40 AND 50). REG. 3-20-2001.
- 2,436,167. SIMPLE SOLUTION. INT. CLS. 3 AND 5. (U.S. CLS. 1, 4, 6, 18, 44, 46, 50, 51 AND 52). REG. 3-20-2001.
- 2,436,267. PAPSURE. INT. CL. 10 ONLY. (U.S. CLS. 26, 39 AND 44). REG. 3-20-2001.
- 2,436,268. GXL. INT. CL. 7. (U.S. CLS. 13, 19, 21, 23, 31, 34 AND 35). REG. 3-20-2001.
- 2,436,305. EL WINGADOR. INT. CL. 41. (U.S. CLS. 100, 101 AND 107). REG. 3-20-2001.
- 2,436,424. SHELTER PAGES. INT. CL. 16. (U.S. CLS. 2, 5, 22, 23, 29, 37, 38 AND 50). REG. 3-20-2001.
- 2,436,469. ALLIGATOR CAPITAL OF THE WORLD. INT. CL. 41. (U.S. CLS. 100, 101 AND 107). REG. 3-20-2001.
- 2,436,641. DIGIMON (STYLIZED). INT. CL. 9. (U.S. CLS. 21, 23, 26, 36 AND 38). REG. 3-20-2001.
- 2,436,706. S AND DESIGN. INT. CL. 9. (U.S. CLS. 21, 23, 26, 36 AND 38). REG. 3-20-2001.
- 2,436,740. AUTOART. INT. CL. 28. (U.S. CLS. 22, 23, 38 AND 50). REG. 3-20-2001.
- 2,436,924. HRD. INT. CL. 33. (U.S. CLS. 47 AND 49). REG. 3-20-2001.
- 2,436,993. PILLSBURY BAKE-OFF AND DESIGN. INT. CL. 41. (U.S. CLS. 100, 101 AND 107). REG. 3-20-2001.
- 2,437,041. MISS BEHAVIN. INT. CL. 12. (U.S. CLS. 19, 21, 23, 31, 35 AND 44). REG. 3-20-2001.
- 2,437,219. MONARCH. INT. CL. 15. (U.S. CLS. 2, 21 AND 36). REG. 3-20-2001.
- 2,437,230. ESSEX BRASS. INT. CL. 14. (U.S. CLS. 2, 27, 28 AND 50). REG. 3-20-2001.
- 2,437,238. SLIM BODY. INT. CL. 3. (U.S. CLS. 1, 4, 6, 50, 51 AND 52). REG. 3-20-2001.
- 2,437,241. SUNDAY RIVER. INT. CL. 24. (U.S. CLS. 42 AND 50). REG. 3-20-2001.
- 2,437,335. CARE RX AND DESIGN. INT. CL. 42. (U.S. CLS. 100 AND 101). REG. 3-20-2001.
- 2,437,483. BRITE SMILE AND DESIGN. INT. CL. 42. (U.S. CLS. 100 AND 101). REG. 3-20-2001.
- 2,437,486. TWICE THE FUN. INT. CL. 28. (U.S. CLS. 22, 23, 38 AND 50). REG. 3-20-2001.
- 2,437,899. CFC. INT. CL. 36. (U.S. CLS. 100, 101 AND 102). REG. 3-27-2001.
- 2,437,921. NOVOFLEX. INT. CL. 7. (U.S. CLS. 13, 19, 21, 23, 31, 34 AND 35). REG. 3-27-2001.
- 2,437,998. SIMATIC MULTI PANEL (STYLIZED). INT. CL. 9. (U.S. CLS. 21, 23, 26, 36 AND 38). REG. 3-27-2001.
- 2,438,010. SYNPHAN. INT. CLS. 9 AND 10. (U.S. CLS. 21, 23, 26, 36, 38, 39 AND 44). REG. 3-27-2001.
- 2,438,234. MISCELLANEOUS DESIGN. INT. CLS. 14, 35 AND 37. (U.S. CLS. 2, 27, 28, 50, 100, 101, 102, 103 AND 106). REG. 3-27-2001.
- 2,438,251. OSTER DIRECT. INT. CL. 37. (U.S. CLS. 100, 103 AND 106). REG. 3-27-2001.
- 2,438,256. GUIDED FLIGHT DISCOVERY. INT. CL. 16. (U.S. CLS. 2, 5, 22, 23, 29, 37, 38 AND 50). REG. 3-27-2001.
- 2,438,312. SHIELDS UP!. INT. CL. 42. (U.S. CLS. 100 AND 101). REG. 3-27-2001.
- 2,438,329. MISCELLANEOUS DESIGN. INT. CL. 30. (U.S. CL. 46). REG. 3-27-2001.
- 2,438,587. MISCELLANEOUS DESIGN. INT. CL. 16. (U.S. CLS. 2, 5, 22, 23, 29, 37, 38 AND 50). REG. 3-27-2001.
- 2,438,588. MISCELLANEOUS DESIGN. INT. CL. 3. (U.S. CLS. 1, 4, 6, 50, 51 AND 52). REG. 3-27-2001.
- 2,438,599. GMRT. INT. CL. 16. (U.S. CLS. 2, 5, 22, 23, 29, 37, 38 AND 50). REG. 3-27-2001.
- 2,438,712. GRIZZLY. INT. CL. 34. (U.S. CLS. 2, 8, 9 AND 17). REG. 3-27-2001.
- 2,439,079. INDESIGN. INT. CL. 9. (U.S. CLS. 21, 23, 26, 36 AND 38). REG. 3-27-2001.
- 2,439,128. BRASWELL FOODS AND DESIGN. INT. CL. 31. (U.S. CLS. 1 AND 46). REG. 3-27-2001.
- 2,439,431. HARDCORE. INT. CL. 28. (U.S. CLS. 22, 23, 38 AND 50). REG. 3-27-2001.
- 2,439,493. GEOSYNC. INT. CL. 9. (U.S. CLS. 21, 23, 26, 36 AND 38). REG. 3-27-2001.
- 2,439,552. CANINE CABLES. INT. CL. 16. (U.S. CLS. 2, 5, 22, 23, 29, 37, 38 AND 50). REG. 3-27-2001.
- 2,439,796. EUROCOPTER. INT. CLS. 12, 28 AND 37 ONLY. (U.S. CLS. 19, 21, 22, 23, 31, 35, 38, 44, 50, 100, 103 AND 106). REG. 4-3-2001.
- 2,440,011. TURNER BUILDING COST INDEX. INT. CL. 37. (U.S. CLS. 100, 103 AND 106). REG. 4-3-2001.
- 2,440,123. EXIT INFORMATION GUIDE LLC AND DESIGN. INT. CL. 16. (U.S. CLS. 2, 5, 22, 23, 29, 37, 38 AND 50). REG. 4-3-2001.
- 2,440,192. JIWANI MADE TO MEASURE. INT. CL. 40. (U.S. CLS. 100, 103 AND 106). REG. 4-3-2001.
- 2,440,291. SOUTHERN LIVING. INT. CL. 42. (U.S. CLS. 100 AND 101). REG. 4-3-2001.
- 2,440,491. MISCELLANEOUS DESIGN. INT. CL. 29. (U.S. CL. 46). REG. 4-3-2001.
- 2,440,579. SIMON SAYS. INT. CL. 36. (U.S. CLS. 100, 101 AND 102). REG. 4-3-2001.
- 2,440,582. SIMON SAYS. INT. CL. 16. (U.S. CLS. 2, 5, 22, 23, 29, 37, 38 AND 50). REG. 4-3-2001.
- 2,440,684. HERTZ FARM MANAGEMENT. INT. CLS. 35 AND 36. (U.S. CLS. 100, 101 AND 102). REG. 4-3-2001.
- 2,440,786. MAPLE CUSTOM. INT. CL. 15. (U.S. CLS. 2, 21 AND 36). REG. 4-3-2001.
- 2,441,039. WHERE WE PUT ALL OF OUR ENERGY. INT. CL. 39. (U.S. CLS. 100 AND 105). REG. 4-3-2001.
- 2,441,048. MISCELLANEOUS DESIGN. INT. CL. 39. (U.S. CLS. 100 AND 105). REG. 4-3-2001.
- 2,441,241. GENGRAF. INT. CL. 5. (U.S. CLS. 6, 18, 44, 46, 51 AND 52). REG. 4-3-2001.
- 2,441,656. MISCELLANEOUS DESIGN. INT. CL. 10. (U.S. CLS. 26, 39 AND 44). REG. 4-3-2001.
- 2,441,687. BEST WEB HOST. INT. CL. 42. (U.S. CLS. 100 AND 101). REG. 4-3-2001.
- 2,441,688. BEST WEB HOSTING. INT. CL. 42. (U.S. CLS. 100 AND 101). REG. 4-3-2001.
- 2,441,730. GRAYBEAR. INT. CL. 25. (U.S. CLS. 22 AND 39). REG. 4-10-2001.

- 2,442,235. HEARTHSONG.COM STANDARD CHARACTER MARK. INT. CL. 35. (U.S. CLS. 100, 101 AND 102). REG. 4-10-2001.
- 2,442,286. MISCELLANEOUS DESIGN. INT. CL. 37. (U.S. CLS. 100, 103 AND 106). REG. 4-10-2001.
- 2,442,345. ES (STYLIZED). INT. CL. 6. (U.S. CLS. 2, 12, 13, 14, 23, 25 AND 50). REG. 4-10-2001.
- 2,442,825. MISCELLANEOUS DESIGN. INT. CL. 41. (U.S. CLS. 100, 101 AND 107). REG. 4-10-2001.
- 2,443,030. PTS2000. INT. CL. 10. (U.S. CLS. 26, 39 AND 44). REG. 4-10-2001.
- 2,443,078. PRIVACYTALK. INT. CL. 9. (U.S. CLS. 21, 23, 26, 36 AND 38). REG. 4-10-2001.
- 2,443,079. PROTALK. INT. CL. 9. (U.S. CLS. 21, 23, 26, 36 AND 38). REG. 4-10-2001.
- 2,443,488. TAHOE. INT. CL. 34. (U.S. CLS. 2, 8, 9 AND 17). REG. 4-10-2001.
- 2,443,750. VOE AND DESIGN. INT. CL. 10. (U.S. CLS. 26, 39 AND 44). REG. 4-17-2001.
- 2,443,811. FERNMASTER. INT. CL. 7. (U.S. CLS. 13, 19, 21, 23, 31, 34 AND 35). REG. 4-17-2001.
- 2,443,874. CHOHUNG. INT. CL. 36. (U.S. CLS. 100, 101 AND 102). REG. 4-17-2001.
- 2,444,288. CAR CASH. INT. CL. 35. (U.S. CLS. 100, 101 AND 102). REG. 4-17-2001.
- 2,444,355. JEWELS & DIAMONDS RX AND DESIGN. INT. CL. 35. (U.S. CLS. 100, 101 AND 102). REG. 4-17-2001.
- 2,444,444. GATES-MACGINITIE READING TESTS. INT. CL. 16. (U.S. CLS. 2, 5, 22, 23, 29, 37, 38 AND 50). REG. 4-17-2001.
- 2,444,569. GMO. INT. CL. 36. (U.S. CLS. 100, 101 AND 102). REG. 4-17-2001.
- 2,444,664. NOVA. INT. CL. 15. (U.S. CLS. 2, 21 AND 36). REG. 4-17-2001.
- 2,444,670. OWNZONE. INT. CLS. 10 AND 14. (U.S. CLS. 2, 26, 27, 28, 39, 44 AND 50). REG. 4-17-2001.
- 2,444,671. OWNCAL. INT. CLS. 10 AND 14. (U.S. CLS. 2, 26, 27, 28, 39, 44 AND 50). REG. 4-17-2001.
- 2,444,848. POWER PAYROLL. INT. CL. 35. (U.S. CLS. 100, 101 AND 102). REG. 4-17-2001.
- 2,444,879. DICK CLARK. INT. CL. 41. (U.S. CLS. 100, 101 AND 107). REG. 4-17-2001.
- 2,445,226. NEXEN. INT. CL. 12. (U.S. CLS. 19, 21, 23, 31, 35 AND 44). REG. 4-17-2001.
- 2,445,383. GLYCEMIC BALANCE. INT. CL. 5. (U.S. CLS. 6, 18, 44, 46, 51 AND 52). REG. 4-24-2001.
- 2,445,403. TASCO AND DESIGN. INT. CL. 35. (U.S. CLS. 100, 101 AND 102). REG. 4-24-2001.
- 2,445,623. CASH BACK NO FLAK!. INT. CL. 35. (U.S. CLS. 100, 101 AND 102). REG. 4-24-2001.
- 2,445,625. HOFFMANN. INT. CL. 9. (U.S. CLS. 21, 23, 26, 36 AND 38). REG. 4-24-2001.
- 2,445,909. POLAR CARE. INT. CL. 10. (U.S. CLS. 26, 39 AND 44). REG. 4-24-2001.
- 2,446,618. TETRA TEBEL BLOCKFORMER. INT. CL. 7. (U.S. CLS. 13, 19, 21, 23, 31, 34 AND 35). REG. 4-24-2001.
- 2,446,742. SONIC INNOVATIONS. INT. CLS. 9 AND 10. (U.S. CLS. 21, 23, 26, 36, 38, 39 AND 44). REG. 4-24-2001.
- 2,446,751. TRUBASS. INT. CL. 9. (U.S. CLS. 21, 23, 26, 36 AND 38). REG. 4-24-2001.
- 2,446,782. DRB-4Z. INT. CL. 11. (U.S. CLS. 13, 21, 23, 31 AND 34). REG. 4-24-2001.
- 2,446,897. COAXREADY. INT. CL. 8. (U.S. CLS. 23, 28 AND 44). REG. 4-24-2001.
- 2,447,108. NATURAL SCENTS. INT. CL. 3. (U.S. CLS. 1, 4, 6, 50, 51 AND 52). REG. 4-24-2001.
- 2,447,220. MULTI-SPOTS. INT. CL. 11. (U.S. CLS. 13, 21, 23, 31 AND 34). REG. 4-24-2001.
- 2,447,566. OLOGY. INT. CL. 41. (U.S. CLS. 100, 101 AND 107). REG. 5-1-2001.
- 2,447,787. STRATAVISOR. INT. CL. 9. (U.S. CLS. 21, 23, 26, 36 AND 38). REG. 5-1-2001.
- 2,447,842. TRIGEL. INT. CL. 4. (U.S. CLS. 1, 6 AND 15). REG. 5-1-2001.
- 2,448,156. VISCOSENSE (STYLIZED). INT. CL. 9. (U.S. CLS. 21, 23, 26, 36 AND 38). REG. 5-1-2001.
- 2,448,285. SPRINT. INT. CL. 10. (U.S. CLS. 26, 39 AND 44). REG. 5-1-2001.
- 2,448,440. SECONDNATURE (STYLIZED). INT. CL. 21. (U.S. CLS. 2, 13, 23, 29, 30, 33, 40 AND 50). REG. 5-1-2001.
- 2,448,445. KITTY KABLES. INT. CL. 16. (U.S. CLS. 2, 5, 22, 23, 29, 37, 38 AND 50). REG. 5-1-2001.
- 2,448,573. ZONEGRAN. INT. CL. 5. (U.S. CLS. 6, 18, 44, 46, 51 AND 52). REG. 5-8-2001.
- 2,448,699. LK AND DESIGN. INT. CL. 7. (U.S. CLS. 13, 19, 21, 23, 31, 34 AND 35). REG. 5-8-2001.
- 2,449,036. CTSLINK. INT. CL. 36. (U.S. CLS. 100, 101 AND 102). REG. 5-8-2001.
- 2,449,300. C-GROOVE. INT. CL. 28. (U.S. CLS. 22, 23, 38 AND 50). REG. 5-8-2001.
- 2,449,410. HOTEL ALLEGRO CHICAGO. INT. CL. 42. (U.S. CLS. 100 AND 101). REG. 5-8-2001.
- 2,449,822. ASTHMA ACTION AMERICA. INT. CL. 16. (U.S. CLS. 2, 5, 22, 23, 29, 37, 38 AND 50). REG. 5-8-2001.
- 2,449,837. BURGER KING AND DESIGN. INT. CL. 28. (U.S. CLS. 22, 23, 38 AND 50). REG. 5-8-2001.
- 2,449,846. YELLOW NEONS. INT. CL. 9. (U.S. CLS. 21, 23, 26, 36 AND 38). REG. 5-8-2001.
- 2,450,107. CREST. INT. CL. 21. (U.S. CLS. 2, 13, 23, 29, 30, 33, 40 AND 50). REG. 5-8-2001.
- 2,450,128. BRAGGI. INT. CL. 25. (U.S. CLS. 22 AND 39). REG. 5-8-2001.
- 2,450,223. AWA. INT. CL. 42. (U.S. CLS. 100 AND 101). REG. 5-8-2001.
- 2,450,265. NEUTROGENA SKINCLEARING. INT. CL. 3. (U.S. CLS. 1, 4, 6, 50, 51 AND 52). REG. 5-8-2001.
- 2,450,355. PARIS88. INT. CL. 35. (U.S. CLS. 100, 101 AND 102). REG. 5-8-2001.
- 2,450,381. PETRO. INT. CL. 42. (U.S. CLS. 100 AND 101). REG. 5-15-2001.
- 2,450,483. ZENAR. INT. CL. 7. (U.S. CLS. 13, 19, 21, 23, 31, 34 AND 35). REG. 5-15-2001.
- 2,451,435. R & M ENERGY SYSTEMS AND DESIGN. INT. CLS. 7 AND 17. (U.S. CLS. 1, 5, 12, 13, 19, 21, 23, 31, 34, 35 AND 50). REG. 5-15-2001.
- 2,451,600. ROYSTON AND DESIGN. INT. CLS. 20 AND 21. (U.S. CLS. 2, 13, 22, 23, 25, 29, 30, 32, 33, 40 AND 50). REG. 5-15-2001.
- 2,451,756. VERSAFIT. INT. CL. 10. (U.S. CLS. 26, 39 AND 44). REG. 5-15-2001.
- 2,451,842. TURRET. INT. CL. 5. (U.S. CLS. 6, 18, 44, 46, 51 AND 52). REG. 5-15-2001.
- 2,452,601. CONTRACTOR SERIES. INT. CL. 8. (U.S. CLS. 23, 28 AND 44). REG. 5-22-2001.
- 2,453,856. CONVERSE.COM. INT. CL. 42. (U.S. CLS. 100 AND 101). REG. 5-22-2001.
- 2,454,058. ROSELAND. INT. CL. 29. (U.S. CL. 46). REG. 5-22-2001.
- 2,454,201. GREEN TEA (STYLIZED). INT. CL. 3. (U.S. CLS. 1, 4, 6, 50, 51 AND 52). REG. 5-22-2001.
- 2,454,209. HEALTHCARE COMMUNICATIONS GROUP. INT. CL. 35. (U.S. CLS. 100, 101 AND 102). REG. 5-22-2001.
- 2,454,228. VET/SENSOR (STYLIZED). INT. CL. 10. (U.S. CLS. 26, 39 AND 44). REG. 5-22-2001.
- 2,454,958. ORVIS. INT. CLS. 35, 39, 40, 41 AND 42. (U.S. CLS. 100, 101, 102, 103, 105, 106 AND 107). REG. 5-29-2001.
- 2,455,120. DR. GEM. INT. CL. 35. (U.S. CLS. 100, 101 AND 102). REG. 5-29-2001.
- 2,455,132. H.O.W AND DESIGN. INT. CL. 39. (U.S. CLS. 100 AND 105). REG. 5-29-2001.
- 2,455,946. CHEMONIC. INT. CL. 1. (U.S. CLS. 1, 5, 6, 10, 26 AND 46). REG. 5-29-2001.
- 2,456,178. LAS VEGAS PAIUTE GOLF RESORT AND DESIGN. INT. CL. 28. (U.S. CLS. 22, 23, 38 AND 50). REG. 5-29-2001.
- 2,456,179. LAS VEGAS PAIUTE GOLF RESORT AND DESIGN. INT. CL. 25. (U.S. CLS. 22 AND 39). REG. 5-29-2001.
- 2,456,478. METALGEAR SOLID. INT. CL. 28. (U.S. CLS. 22, 23, 38 AND 50). REG. 5-29-2001.
- 2,456,574. COLORS AND DESIGN. INT. CL. 3. (U.S. CLS. 1, 4, 6, 50, 51 AND 52). REG. 6-5-2001.
- 2,456,616. WONDERLINE. INT. CL. 28. (U.S. CLS. 22, 23, 38 AND 50). REG. 6-5-2001.
- 2,456,675. THINKMATE. INT. CL. 9. (U.S. CLS. 21, 23, 26, 36 AND 38). REG. 6-5-2001.
- 2,457,084. EXTENDED STAY AMERICA. INT. CL. 42. (U.S. CLS. 100 AND 101). REG. 6-5-2001.
- 2,457,102. AEZ. INT. CL. 12. (U.S. CLS. 19, 21, 23, 31, 35 AND 44). REG. 6-5-2001.
- 2,457,143. QUIKTURN. INT. CL. 3. (U.S. CLS. 1, 4, 6, 50, 51 AND 52). REG. 6-5-2001.

- 2,457,243. THE LATE LATE SHOW. INT. CL. 41. (U.S. CLS. 100, 101 AND 107). REG. 6-5-2001.
- 2,457,349. JILL OF ALL TRADES. INT. CL. 37. (U.S. CLS. 100, 103 AND 106). REG. 6-5-2001.
- 2,457,526. UNION PLUS. INT. CL. 36. (U.S. CLS. 100, 101 AND 102). REG. 6-5-2001.
- 2,458,279. TALON. INT. CL. 9. (U.S. CLS. 21, 23, 26, 36 AND 38). REG. 6-5-2001.
- 2,458,567. THE RELUCTANT GOURMET. INT. CL. 42. (U.S. CLS. 100 AND 101). REG. 6-5-2001.
- 2,458,815. CRYSTAL SAND. INT. CL. 11. (U.S. CLS. 13, 21, 23, 31 AND 34). REG. 6-5-2001.
- 2,458,905. PROGRESSIVE BLACK JACK AND DESIGN. INT. CL. 28. (U.S. CLS. 22, 23, 38 AND 50). REG. 6-12-2001.
- 2,459,122. MISCELLANEOUS DESIGN. INT. CL. 36. (U.S. CLS. 100, 101 AND 102). REG. 6-12-2001.
- 2,459,239. THE RECORD (STYLIZED). INT. CL. 16. (U.S. CLS. 2, 5, 22, 23, 29, 37, 38 AND 50). REG. 6-12-2001.
- 2,459,572. RELIC-TRONICS. INT. CL. 37. (U.S. CLS. 100, 103 AND 106). REG. 6-12-2001.
- 2,459,903. DAMAGE CONTROL. INT. CL. 3. (U.S. CLS. 1, 4, 6, 50, 51 AND 52). REG. 6-12-2001.
- 2,459,977. BLUE RIBBON BRAND TEXAS TRADITIONS CO.. INT. CL. 29. (U.S. CL. 46). REG. 6-12-2001.
- 2,460,236. AH-64D APACHE LONGBOW. INT. CL. 28. (U.S. CLS. 22, 23, 38 AND 50). REG. 6-12-2001.
- 2,460,249. GARLIGUARD (STYLIZED). INT. CL. 5. (U.S. CLS. 6, 18, 44, 46, 51 AND 52). REG. 6-12-2001.
- 2,460,385. NEVADA COMPANY ONE, INC. AND DESIGN. INT. CL. 37. (U.S. CLS. 100, 103 AND 106). REG. 6-12-2001.
- 2,460,456. SOLUTION STATION. INT. CLS. 3, 5 AND 21. (U.S. CLS. 1, 2, 4, 6, 13, 18, 23, 29, 30, 33, 40, 44, 46, 50, 51 AND 52). REG. 6-12-2001.
- 2,460,857. GIVE UP BAD COFFEE, FOR GOOD. INT. CL. 21 ONLY. (U.S. CLS. 2, 13, 23, 29, 30, 33, 40 AND 50). REG. 6-19-2001.
- 2,460,913. IBIS AND DESIGN. INT. CL. 30. (U.S. CL. 46). REG. 6-19-2001.
- 2,461,003. MAKE IT WORK. INT. CL. 37. (U.S. CLS. 100, 103 AND 106). REG. 6-19-2001.
- 2,461,035. K AND DESIGN. INT. CLS. 7 AND 12. (U.S. CLS. 13, 19, 21, 23, 31, 34, 35 AND 44). REG. 6-19-2001.
- 2,461,160. MISCELLANEOUS DESIGN. INT. CL. 42. (U.S. CLS. 100 AND 101). REG. 6-19-2001.
- 2,461,489. 2 SMART 2 SMOKE. INT. CL. 41. (U.S. CLS. 100, 101 AND 107). REG. 6-19-2001.
- 2,461,490. POWERCLAMP. INT. CL. 7. (U.S. CLS. 13, 19, 21, 23, 31, 34 AND 35). REG. 6-19-2001.
- 2,462,035. RED AND WHITE. INT. CL. 39. (U.S. CLS. 100 AND 105). REG. 6-19-2001.
- 2,462,238. ADJUST-A-NET. INT. CL. 9. (U.S. CLS. 21, 23, 26, 36 AND 38). REG. 6-19-2001.
- 2,462,550. LAS VEGAS PAIUTE GOLF RESORT AND DESIGN. INT. CL. 16. (U.S. CLS. 2, 5, 22, 23, 29, 37, 38 AND 50). REG. 6-19-2001.
- 2,463,082. ULTRACAS. INT. CL. 1. (U.S. CLS. 1, 5, 6, 10, 26 AND 46). REG. 6-26-2001.
- 2,463,128. LIQUILINK. INT. CL. 1. (U.S. CLS. 1, 5, 6, 10, 26 AND 46). REG. 6-26-2001.
- 2,463,406. E AND DESIGN. INT. CL. 16 ONLY. (U.S. CLS. 2, 5, 22, 23, 29, 37, 38 AND 50). REG. 6-26-2001.
- 2,464,187. WE WILL SELL YOUR HOUSE OR ERA WILL BUY IT. INT. CL. 36. (U.S. CLS. 100, 101 AND 102). REG. 6-26-2001.
- 2,464,490. INSTYLE MAKEOVER. INT. CL. 16. (U.S. CLS. 2, 5, 22, 23, 29, 37, 38 AND 50). REG. 6-26-2001.
- 2,464,947. MCFUTURE AND DESIGN. INT. CLS. 35 AND 41. (U.S. CLS. 100, 101, 102 AND 107). REG. 7-3-2001.
- 2,464,987. BEAUTY BLACKBOOK. INT. CL. 16. (U.S. CLS. 2, 5, 22, 23, 29, 37, 38 AND 50). REG. 7-3-2001.
- 2,465,135. MISCELLANEOUS DESIGN. INT. CL. 35. (U.S. CLS. 100, 101 AND 102). REG. 7-3-2001.
- 2,465,153. ORLANDO MAGICARD. INT. CLS. 16 AND 35. (U.S. CLS. 2, 5, 22, 23, 29, 37, 38, 50, 100, 101 AND 102). REG. 7-3-2001.
- 2,465,412. STRESS FREE. INT. CL. 7. (U.S. CLS. 13, 19, 21, 23, 31, 34 AND 35). REG. 7-3-2001.
- 2,465,508. CLAUSEN MILLER. INT. CL. 42. (U.S. CLS. 100 AND 101). REG. 7-3-2001.
- 2,465,741. BUILDING BETTER COMPANIES. BUILDING BETTER CAREERS.. INT. CL. 35. (U.S. CLS. 100, 101 AND 102). REG. 7-3-2001.
- 2,465,902. THE WORLD OF RESIDENSEA. INT. CL. 36. (U.S. CLS. 100, 101 AND 102). REG. 7-3-2001.
- 2,466,089. STRESS LESS. INT. CL. 5. (U.S. CLS. 6, 18, 44, 46, 51 AND 52). REG. 7-3-2001.
- 2,466,116. DIAMOND ACE. INT. CLS. 7 AND 12. (U.S. CLS. 13, 19, 21, 23, 31, 34, 35 AND 44). REG. 7-3-2001.
- 2,466,259. THE COMPRESSOR PROFESSOR. INT. CL. 41. (U.S. CLS. 100, 101 AND 107). REG. 7-3-2001.
- 2,466,627. LEANLOGISTICS. INT. CL. 39. (U.S. CLS. 100 AND 105). REG. 7-3-2001.
- 2,466,655. QUACKER JACK. INT. CL. 41. (U.S. CLS. 100, 101 AND 107). REG. 7-3-2001.
- 2,466,805. DREAM A LITTLE... SWEAT A LOT.... INT. CL. 25. (U.S. CLS. 22 AND 39). REG. 7-3-2001.
- 2,466,838. WINNERS CIRCLE. INT. CL. 42. (U.S. CLS. 100 AND 101). REG. 7-10-2001.
- 2,466,902. EPOS. INT. CL. 10. (U.S. CLS. 26, 39 AND 44). REG. 7-10-2001.
- 2,466,961. HACIENDA. INT. CL. 30. (U.S. CL. 46). REG. 7-10-2001.
- 2,467,512. COMPLIANCE IN A CAN. INT. CL. 9. (U.S. CLS. 21, 23, 26, 36 AND 38). REG. 7-10-2001.
- 2,468,030. KYMA. INT. CL. 9. (U.S. CLS. 21, 23, 26, 36 AND 38). REG. 7-10-2001.
- 2,468,374. TEAM LA. INT. CL. 35. (U.S. CLS. 100, 101 AND 102). REG. 7-10-2001.
- 2,468,396. XHALE. INT. CLS. 16 AND 42. (U.S. CLS. 2, 5, 22, 23, 29, 37, 38, 50, 100 AND 101). REG. 7-10-2001.
- 2,469,331. CONTINUUM. INT. CL. 33. (U.S. CLS. 47 AND 49). REG. 7-17-2001.
- 2,469,450. YA YA PRO-TECT AND DESIGN. INT. CL. 17. (U.S. CLS. 1, 5, 12, 13, 35 AND 50). REG. 7-17-2001.
- 2,469,575. I-BEHAVIOR AND DESIGN. INT. CL. 35. (U.S. CLS. 100, 101 AND 102). REG. 7-17-2001.
- 2,470,095. S SKILCRAFT AND DESIGN. INT. CL. 35. (U.S. CLS. 100, 101 AND 102). REG. 7-17-2001.
- 2,470,110. DKNY. INT. CL. 25. (U.S. CLS. 22 AND 39). REG. 7-17-2001.
- 2,470,247. STK/ASTROGATOR. INT. CL. 9. (U.S. CLS. 21, 23, 26, 36 AND 38). REG. 7-17-2001.
- 2,470,318. CLEVERCAT. INT. CL. 21. (U.S. CLS. 2, 13, 23, 29, 30, 33, 40 AND 50). REG. 7-17-2001.
- 2,470,878. INTERNATIONAL CARWASH ASSOCIATION AND DESIGN. INT. CL. 35. (U.S. CLS. 100, 101 AND 102). REG. 7-24-2001.
- 2,471,083. ITTY BITTY BONES. INT. CL. 31. (U.S. CLS. 1 AND 46). REG. 7-24-2001.
- 2,471,331. THERMAL ANGEL. INT. CL. 10. (U.S. CLS. 26, 39 AND 44). REG. 7-24-2001.
- 2,471,649. EDUSPEAK. INT. CL. 9. (U.S. CLS. 21, 23, 26, 36 AND 38). REG. 7-24-2001.
- 2,471,685. BLUE BAHAMA. INT. CL. 16. (U.S. CLS. 2, 5, 22, 23, 29, 37, 38 AND 50). REG. 7-24-2001.
- 2,471,746. EDUSPEAK AND DESIGN. INT. CL. 9. (U.S. CLS. 21, 23, 26, 36 AND 38). REG. 7-24-2001.
- 2,471,805. THE ULTIMATE ADDRESS: THE WORLD. INT. CL. 36. (U.S. CLS. 100, 101 AND 102). REG. 7-24-2001.
- 2,472,193. NEXTGEN AND DESIGN. INT. CL. 36. (U.S. CLS. 100, 101 AND 102). REG. 7-24-2001.
- 2,473,232. ULTRA GARLITE. INT. CL. 5. (U.S. CLS. 6, 18, 44, 46, 51 AND 52). REG. 7-31-2001.
- 2,473,394. SUNDOWN AND DESIGN. INT. CL. 5. (U.S. CLS. 6, 18, 44, 46, 51 AND 52). REG. 7-31-2001.
- 2,473,658. LINKO. INT. CL. 7. (U.S. CLS. 13, 19, 21, 23, 31, 34 AND 35). REG. 7-31-2001.
- 2,473,723. GRIPRITE. INT. CL. 20. (U.S. CLS. 2, 13, 22, 25, 32 AND 50). REG. 7-31-2001.
- 2,473,876. U AND DESIGN. INT. CL. 9. (U.S. CLS. 21, 23, 26, 36 AND 38). REG. 7-31-2001.
- 2,474,432. MOLE MOVER. INT. CL. 9. (U.S. CLS. 21, 23, 26, 36 AND 38). REG. 7-31-2001.
- 2,474,738. SHATTERGARD (STYLIZED). INT. CL. 17. (U.S. CLS. 1, 5, 12, 13, 35 AND 50). REG. 8-7-2001.
- 2,474,853. EPATENT. INT. CL. 35. (U.S. CLS. 100, 101 AND 102). REG. 8-7-2001.
- 2,475,025. AAR. INT. CLS. 6, 7, 12, 19, 20, 35, 37, 39 AND 42. (U.S. CLS. 1, 2, 12, 13, 14, 19, 21, 22, 23, 25, 31, 32, 33, 34, 35, 44, 50, 100, 101, 102, 103, 105 AND 106). REG. 8-7-2001.
- 2,475,028. ROYAL SHELL VACATIONS. INT. CLS. 35 AND 42 ONLY. (U.S. CLS. 100, 101 AND 102). REG. 8-7-2001.



- 2,475,585. TT. INT. CL. 9. (U.S. CLS. 21, 23, 26, 36 AND 38). REG. 8-7-2001.
- 2,475,589. OSSIDIANA. INT. CL. 33. (U.S. CLS. 47 AND 49). REG. 8-7-2001.
- 2,475,693. MINITWIST. INT. CL. 11. (U.S. CLS. 13, 21, 23, 31 AND 34). REG. 8-7-2001.
- 2,475,909. BUILD-A-TRUCK. INT. CL. 40. (U.S. CLS. 100, 103 AND 106). REG. 8-7-2001.
- 2,476,212. DRYTEX. INT. CL. 22. (U.S. CLS. 1, 2, 7, 19, 22, 42 AND 50). REG. 8-7-2001.
- 2,476,288. COLOR WORKS. INT. CL. 16. (U.S. CLS. 2, 5, 22, 23, 29, 37, 38 AND 50). REG. 8-7-2001.
- 2,476,425. NEXTGEN COLLEGE INVESTING PLAN. INT. CL. 36. (U.S. CLS. 100, 101 AND 102). REG. 8-7-2001.
- 2,476,434. THE COLLEGE INVESTING PLAN FOR THE NEXT GENERATION. INT. CL. 36. (U.S. CLS. 100, 101 AND 102). REG. 8-7-2001.
- 2,476,769. SHAPE. INT. CL. 30. (U.S. CL. 46). REG. 8-7-2001.
- 2,477,005. BS BRILLIANT AND DESIGN. INT. CL. 33. (U.S. CLS. 47 AND 49). REG. 8-14-2001.
- 2,477,197. ALWAYS THERE FOR YOU. INT. CL. 36. (U.S. CLS. 100, 101 AND 102). REG. 8-14-2001.
- 2,477,495. CHAMPION. INT. CL. 7. (U.S. CLS. 13, 19, 21, 23, 31, 34 AND 35). REG. 8-14-2001.
- 2,478,063. COLTEX AND DESIGN. INT. CL. 16. (U.S. CLS. 2, 5, 22, 23, 29, 37, 38 AND 50). REG. 8-14-2001.
- 2,478,091. ETRUSCA. INT. CL. 42. (U.S. CLS. 100 AND 101). REG. 8-14-2001.
- 2,478,190. HILTON. INT. CL. 42. (U.S. CLS. 100 AND 101). REG. 8-14-2001.
- 2,478,347. MITE-E-OIL. INT. CL. 5. (U.S. CLS. 6, 18, 44, 46, 51 AND 52). REG. 8-14-2001.
- 2,478,818. DENTSPLY. INT. CLS. 5 AND 10. (U.S. CLS. 6, 18, 26, 39, 44, 46, 51 AND 52). REG. 8-21-2001.
- 2,478,891. CARSDIRECT.COM. INT. CLS. 35 AND 39. (U.S. CLS. 100, 101, 102 AND 105). REG. 8-21-2001.
- 2,479,195. CALIFORNIA WALNUTS AND DESIGN. INT. CL. 35. (U.S. CLS. 100, 101 AND 102). REG. 8-21-2001.
- 2,479,328. SPORT COURT. INT. CL. 19. (U.S. CLS. 1, 12, 33 AND 50). REG. 8-21-2001.
- 2,479,341. HARRY POTTER. INT. CL. 20. (U.S. CLS. 2, 13, 22, 25, 32 AND 50). REG. 8-21-2001.
- 2,479,455. IT'S THE RIDE. INT. CL. 35. (U.S. CLS. 100, 101 AND 102). REG. 8-21-2001.
- 2,479,547. JEWELS & DIAMONDS RX AND DESIGN. INT. CL. 14. (U.S. CLS. 2, 27, 28 AND 50). REG. 8-21-2001.
- 2,479,647. THERMALTAKE. INT. CL. 9. (U.S. CLS. 21, 23, 26, 36 AND 38). REG. 8-21-2001.
- 2,480,023. WE'RE WITH YOU ALL THE WAY.. INT. CL. 42. (U.S. CLS. 100 AND 101). REG. 8-21-2001.
- 2,480,064. HAMPTON AND DESIGN. INT. CL. 42. (U.S. CLS. 100 AND 101). REG. 8-21-2001.
- 2,480,300. JOBSERVE (STYLIZED). INT. CL. 35. (U.S. CLS. 100, 101 AND 102). REG. 8-21-2001.
- 2,480,453. METHOD. INT. CLS. 40 AND 42. (U.S. CLS. 100, 101, 103 AND 106). REG. 8-21-2001.
- 2,480,506. GOLEAN. INT. CL. 30. (U.S. CL. 46). REG. 8-21-2001.
- 2,480,546. SERVASSURE DEALERS. INT. CL. 37. (U.S. CLS. 100, 103 AND 106). REG. 8-21-2001.
- 2,480,772. COMPUGUARD. INT. CL. 9. (U.S. CLS. 21, 23, 26, 36 AND 38). REG. 8-21-2001.
- 2,481,132. CAVION. INT. CLS. 38 AND 42. (U.S. CLS. 100, 101 AND 104). REG. 8-28-2001.
- 2,481,225. FORMCRETE. INT. CL. 19. (U.S. CLS. 1, 12, 33 AND 50). REG. 8-28-2001.
- 2,481,491. GRADELOK. INT. CL. 11. (U.S. CLS. 13, 21, 23, 31 AND 34). REG. 8-28-2001.
- 2,481,873. ROSECORE. INT. CL. 27 ONLY. (U.S. CLS. 19, 20, 37, 42 AND 50). REG. 8-28-2001.
- 2,482,018. TRU-FLATE. INT. CLS. 7 AND 9. (U.S. CLS. 13, 19, 21, 23, 26, 31, 34, 35, 36 AND 38). REG. 8-28-2001.
- 2,482,431. HAMPTON. INT. CL. 42. (U.S. CLS. 100 AND 101). REG. 8-28-2001.
- 2,482,665. MT. EVEREST. INT. CL. 25. (U.S. CLS. 22 AND 39). REG. 8-28-2001.
- 2,482,797. EDISOFT. INT. CL. 9. (U.S. CLS. 21, 23, 26, 36 AND 38). REG. 8-28-2001.
- 2,482,917. EXTREME. INT. CL. 9. (U.S. CLS. 21, 23, 26, 36 AND 38). REG. 8-28-2001.
- 2,483,615. MCGUIREWOODS. INT. CL. 42. (U.S. CLS. 100 AND 101). REG. 8-28-2001.
- 2,483,876. MIRAGE. INT. CL. 2. (U.S. CLS. 6, 11 AND 16). REG. 8-28-2001.
- 2,484,346. THE HARBOR PLANNING GROUP, INC.. INT. CLS. 36 AND 37. (U.S. CLS. 100, 101, 102, 103 AND 106). REG. 9-4-2001.
- 2,484,355. PROFITMAKER. INT. CL. 9. (U.S. CLS. 21, 23, 26, 36 AND 38). REG. 9-4-2001.
- 2,486,012. AMBERGEN. INT. CL. 1. (U.S. CLS. 1, 5, 6, 10, 26 AND 46). REG. 9-4-2001.
- 2,486,984. MISCELLANEOUS DESIGN. INT. CLS. 9 AND 16. (U.S. CLS. 2, 5, 21, 22, 23, 26, 29, 36, 37, 38 AND 50). REG. 9-11-2001.
- 2,487,654. RILEY AND DESIGN. INT. CL. 29. (U.S. CL. 46). REG. 9-11-2001.
- 2,488,822. INTO THE OUTDOORS. INT. CLS. 38 AND 41. (U.S. CLS. 100, 101, 104 AND 107). REG. 9-11-2001.
- 2,489,135. MUSICPRO INSURANCE. INT. CL. 36. (U.S. CLS. 100, 101 AND 102). REG. 9-11-2001.
- 2,489,623. DIFFUSION/FX. INT. CL. 9. (U.S. CLS. 21, 23, 26, 36 AND 38). REG. 9-11-2001.
- 2,489,694. CLEANINGEXPO. INT. CL. 35. (U.S. CLS. 100, 101 AND 102). REG. 9-11-2001.
- 2,489,945. SPENCER STUART BOARD INDEX. INT. CL. 16. (U.S. CLS. 2, 5, 22, 23, 29, 37, 38 AND 50). REG. 9-18-2001.
- 2,490,225. MEDECISION (STYLIZED). INT. CLS. 9 AND 36. (U.S. CLS. 21, 23, 26, 36, 38, 100, 101 AND 102). REG. 9-18-2001.
- 2,490,366. PERKINS RESTAURANT & BAKERY. INT. CLS. 30 AND 42. (U.S. CLS. 46, 100 AND 101). REG. 9-18-2001.
- 2,490,386. CUTDATA. INT. CL. 42. (U.S. CLS. 100 AND 101). REG. 9-18-2001.
- 2,490,527. SCHULZ (STYLIZED). INT. CL. 41. (U.S. CLS. 100, 101 AND 107). REG. 9-18-2001.
- 2,490,789. EXTRAORDINARY SMILES. INT. CL. 42. (U.S. CLS. 100 AND 101). REG. 9-18-2001.
- 2,491,400. DRAGONFISH ASIAN CAFE. INT. CL. 42. (U.S. CLS. 100 AND 101). REG. 9-18-2001.
- 2,491,403. HIGH ROAD. INT. CL. 12 ONLY. (U.S. CLS. 19, 21, 23, 31, 35 AND 44). REG. 9-18-2001.
- 2,491,465. THE JEWISH MONITOR. INT. CL. 16. (U.S. CLS. 2, 5, 22, 23, 29, 37, 38 AND 50). REG. 9-18-2001.
- 2,491,723. FRANK'S AND DESIGN. INT. CLS. 6, 17, 35 AND 37 ONLY. (U.S. CLS. 1, 2, 5, 12, 13, 14, 23, 25, 35, 50, 100, 101, 102, 103 AND 106). REG. 9-25-2001.
- 2,491,960. MINNESOTA GOLFER. INT. CL. 16. (U.S. CLS. 2, 5, 22, 23, 29, 37, 38 AND 50). REG. 9-25-2001.
- 2,492,063. CONCORD MUSEUM. INT. CLS. 35 AND 41. (U.S. CLS. 100, 101, 102 AND 107). REG. 9-25-2001.
- 2,492,247. PERKINS RESTAURANT & BAKERY AND DESIGN. INT. CLS. 30 AND 42. (U.S. CLS. 46, 100 AND 101). REG. 9-25-2001.
- 2,493,190. THOMAS STEELE. INT. CLS. 20 AND 21 ONLY. (U.S. CLS. 2, 13, 22, 23, 25, 29, 30, 32, 33, 40 AND 50). REG. 9-25-2001.
- 2,493,325. OPTIMIZE. INT. CL. 5. (U.S. CLS. 6, 18, 44, 46, 51 AND 52). REG. 9-25-2001.
- 2,493,445. RX-STRENGTH. INT. CL. 5. (U.S. CLS. 6, 18, 44, 46, 51 AND 52). REG. 9-25-2001.
- 2,494,112. THE HOLY LAND EXPERIENCE. INT. CLS. 16, 25 AND 41. (U.S. CLS. 2, 5, 22, 23, 29, 37, 38, 39, 50, 100, 101 AND 107). REG. 10-2-2001.
- 2,494,140. EMILIO'S TERRACE. INT. CL. 33. (U.S. CLS. 47 AND 49). REG. 10-2-2001.
- 2,494,405. THE KNOT. INT. CL. 16. (U.S. CLS. 2, 5, 22, 23, 29, 37, 38 AND 50). REG. 10-2-2001.
- 2,494,483. NAVIGATOR. INT. CL. 12. (U.S. CLS. 19, 21, 23, 31, 35 AND 44). REG. 10-2-2001.
- 2,494,527. HESKA. INT. CL. 5. (U.S. CLS. 6, 18, 44, 46, 51 AND 52). REG. 10-2-2001.
- 2,494,703. ALGAE MAX. INT. CL. 5. (U.S. CLS. 6, 18, 44, 46, 51 AND 52). REG. 10-2-2001.
- 2,494,979. KOBI. INT. CL. 14. (U.S. CLS. 2, 27, 28 AND 50). REG. 10-2-2001.
- 2,495,671. FLEXI-HINGE. INT. CL. 9. (U.S. CLS. 21, 23, 26, 36 AND 38). REG. 10-9-2001.
- 2,495,901. CUTDATA. INT. CL. 9. (U.S. CLS. 21, 23, 26, 36 AND 38). REG. 10-9-2001.
- 2,495,905. LAKE CAROLINA AND DESIGN. INT. CLS. 36 AND 37. (U.S. CLS. 100, 101, 102, 103 AND 106). REG. 10-9-2001.
- 2,495,912. WONDER KIDS (STYLIZED). INT. CL. 9. (U.S. CLS. 21, 23, 26, 36 AND 38). REG. 10-9-2001.

- 2,495,982. FEED YOUR SPIRIT. INT. CL. 42. (U.S. CLS. 100 AND 101). REG. 10-9-2001.
- 2,496,179. T'AI CHI CHIH. INT. CL. 41. (U.S. CLS. 100, 101 AND 107). REG. 10-9-2001.
- 2,496,383. INSPECT USA AND DESIGN. INT. CL. 42. (U.S. CLS. 100 AND 101). REG. 10-9-2001.
- 2,496,526. IMPACT PRODUCTIONS. INT. CLS. 35 AND 41. (U.S. CLS. 100, 101, 102 AND 107). REG. 10-9-2001.
- 2,496,994. INFINI-T. INT. CL. 6. (U.S. CLS. 2, 12, 13, 14, 23, 25 AND 50). REG. 10-9-2001.
- 2,497,542. DATATAKER. INT. CL. 9. (U.S. CLS. 21, 23, 26, 36 AND 38). REG. 10-16-2001.
- 2,498,198. RODEY, DICKASON, SLOAN, AKIN & ROBB. INT. CL. 42. (U.S. CLS. 100 AND 101). REG. 10-16-2001.
- 2,498,661. CURIOUS GEORGE. INT. CL. 41. (U.S. CLS. 100, 101 AND 107). REG. 10-16-2001.
- 2,499,003. FITKID. INT. CL. 28. (U.S. CLS. 22, 23, 38 AND 50). REG. 10-16-2001.
- 2,499,178. MANNING'S COOKIE SHOP. INT. CL. 30. (U.S. CL. 46). REG. 10-16-2001.
- 2,499,467. PEOPLE LINK. INT. CLS. 41 AND 42. (U.S. CLS. 100, 101 AND 107). REG. 10-23-2001.
- 2,500,394. THE BROWN DAILY HERALD. INT. CL. 16. (U.S. CLS. 2, 5, 22, 23, 29, 37, 38 AND 50). REG. 10-23-2001.
- 2,500,618. VIPROBE. INT. CL. 9. (U.S. CLS. 21, 23, 26, 36 AND 38). REG. 10-23-2001.
- 2,500,669. METHODOLOGIE. INT. CL. 35. (U.S. CLS. 100, 101 AND 102). REG. 10-23-2001.
- 2,501,590. ENDUIT. INT. CL. 17. (U.S. CLS. 1, 5, 12, 13, 35 AND 50). REG. 10-30-2001.
- 2,501,751. NU-WHIP. INT. CL. 29. (U.S. CL. 46). REG. 10-30-2001.
- 2,502,179. HIGHLINE. INT. CL. 36. (U.S. CLS. 100, 101 AND 102). REG. 10-30-2001.
- 2,502,593. COMMUNITY BANK AND DESIGN. INT. CL. 36. (U.S. CLS. 100, 101 AND 102). REG. 10-30-2001.
- 2,502,691. DIMENSIONS. INT. CL. 2. (U.S. CLS. 6, 11 AND 16). REG. 10-30-2001.
- 2,502,695. TEMPSAFE. INT. CL. 9. (U.S. CLS. 21, 23, 26, 36 AND 38). REG. 10-30-2001.
- 2,502,969. OCEAN CROWN. INT. CL. 29. (U.S. CL. 46). REG. 10-30-2001.
- 2,503,073. VALLEY SELECT. INT. CL. 31. (U.S. CLS. 1 AND 46). REG. 10-30-2001.
- 2,503,619. THE CHICAGO JEWISH NEWS. INT. CLS. 16, 41 AND 42. (U.S. CLS. 2, 5, 22, 23, 29, 37, 38, 50, 100, 101 AND 107). REG. 11-6-2001.
- 2,503,658. CIPE. INT. CL. 42. (U.S. CLS. 100 AND 101). REG. 11-6-2001.
- 2,503,865. SERVICEMASTER CLEAN AND DESIGN. INT. CL. 37. (U.S. CLS. 100, 103 AND 106). REG. 11-6-2001.
- 2,504,138. SIREN INTERACTIVE. INT. CL. 42. (U.S. CLS. 100 AND 101). REG. 11-6-2001.
- 2,504,140. MISCELLANEOUS DESIGN. INT. CL. 42. (U.S. CLS. 100 AND 101). REG. 11-6-2001.
- 2,504,479. STAPLES CENTER. INT. CLS. 21, 25, 35 AND 41. (U.S. CLS. 2, 13, 22, 23, 29, 30, 33, 39, 40, 50, 100, 101, 102 AND 107). REG. 11-6-2001.
- 2,504,972. TOUCHTUNE. INT. CL. 10. (U.S. CLS. 26, 39 AND 44). REG. 11-6-2001.
- 2,505,036. ORIGINAL DUBBLE BUBBLE AND DESIGN. INT. CL. 30. (U.S. CL. 46). REG. 11-6-2001.
- 2,505,955. LYOSTAR. INT. CL. 11. (U.S. CLS. 13, 21, 23, 31 AND 34). REG. 11-13-2001.
- 2,505,976. ALFA-RACK. INT. CL. 31. (U.S. CLS. 1 AND 46). REG. 11-13-2001.
- 2,506,090. HOT JAVA COOL BLUES BEANS WITH A BEAT AND DESIGN. INT. CL. 42. (U.S. CLS. 100 AND 101). REG. 11-13-2001.
- 2,506,293. PARKINOL. INT. CL. 5. (U.S. CLS. 6, 18, 44, 46, 51 AND 52). REG. 11-13-2001.
- 2,506,698. SPECTRE. INT. CL. 12. (U.S. CLS. 19, 21, 23, 31, 35 AND 44). REG. 11-13-2001.
- 2,506,699. VENGEANCE. INT. CL. 12. (U.S. CLS. 19, 21, 23, 31, 35 AND 44). REG. 11-13-2001.
- 2,506,700. VELOCITY. INT. CL. 12. (U.S. CLS. 19, 21, 23, 31, 35 AND 44). REG. 11-13-2001.
- 2,507,155. CAT. INT. CL. 6. (U.S. CLS. 2, 12, 13, 14, 23, 25 AND 50). REG. 11-13-2001.
- 2,507,353. ROCKET. INT. CL. 28. (U.S. CLS. 22, 23, 38 AND 50). REG. 11-13-2001.
- 2,507,915. MORE STYLES. MORE CHOICES. MORE AFFORDABLE. INT. CL. 35. (U.S. CLS. 100, 101 AND 102). REG. 11-13-2001.
- 2,508,074. GIZMO BEACH. INT. CL. 42. (U.S. CLS. 100 AND 101). REG. 11-13-2001.
- 2,509,394. MAX YUMM. INT. CL. 30. (U.S. CL. 46). REG. 11-20-2001.
- 2,509,632. UA UNDER ARMOUR AND DESIGN. INT. CL. 25. (U.S. CLS. 22 AND 39). REG. 11-20-2001.
- 2,509,741. SOLO STEP. INT. CL. 10. (U.S. CLS. 26, 39 AND 44). REG. 11-20-2001.
- 2,510,891. HARD DATA FOR HARD DECISIONS. INT. CL. 35. (U.S. CLS. 100, 101 AND 102). REG. 11-20-2001.
- 2,511,545. IOMED. INT. CL. 5. (U.S. CLS. 6, 18, 44, 46, 51 AND 52). REG. 11-27-2001.
- 2,511,632. HARVEL AND DESIGN. INT. CL. 17. (U.S. CLS. 1, 5, 12, 13, 35 AND 50). REG. 11-27-2001.
- 2,511,844. WHITETAIL INSTITUTE OF NORTH AMERICA. INT. CLS. 5, 31 AND 35. (U.S. CLS. 1, 6, 18, 44, 46, 51, 52, 100, 101 AND 102). REG. 11-27-2001.
- 2,512,038. APPLIQUE ACADEMY (STYLIZED). INT. CL. 41. (U.S. CLS. 100, 101 AND 107). REG. 11-27-2001.
- 2,512,201. INVICTA LAW GROUP. INT. CL. 42. (U.S. CLS. 100 AND 101). REG. 11-27-2001.
- 2,512,267. OWLINK. INT. CL. 41. (U.S. CLS. 100, 101 AND 107). REG. 11-27-2001.
- 2,512,272. OWLNET. INT. CL. 41. (U.S. CLS. 100, 101 AND 107). REG. 11-27-2001.
- 2,512,749. MISCELLANEOUS DESIGN. INT. CL. 9. (U.S. CLS. 21, 23, 26, 36 AND 38). REG. 11-27-2001.
- 2,512,889. GAP. INT. CL. 35. (U.S. CLS. 100, 101 AND 102). REG. 11-27-2001.
- 2,513,306. CHEESE DOUBLE CHEESE. INT. CL. 30. (U.S. CL. 46). REG. 11-27-2001.
- 2,513,810. EXPRESSED WISHES. INT. CL. 42 ONLY. (U.S. CLS. 100 AND 101). REG. 12-4-2001.
- 2,515,190. HTB. INT. CL. 4. (U.S. CLS. 1, 6 AND 15). REG. 12-4-2001.
- 2,516,019. WONDERWORD. INT. CL. 16. (U.S. CLS. 2, 5, 22, 23, 29, 37, 38 AND 50). REG. 12-11-2001.
- 2,517,149. THE UNIVERSITY OF TEXAS-PAN AMERICAN STANDARD CHARACTER MARK. INT. CL. 25. (U.S. CLS. 22 AND 39). REG. 12-11-2001.
- 2,517,439. BLACK KNIGHT. INT. CL. 9. (U.S. CLS. 21, 23, 26, 36 AND 38). REG. 12-11-2001.
- 2,517,440. SKINNY DIP. INT. CL. 9. (U.S. CLS. 21, 23, 26, 36 AND 38). REG. 12-11-2001.
- 2,517,485. DIAZTECA AND DESIGN. INT. CL. 31. (U.S. CLS. 1 AND 46). REG. 12-11-2001.
- 2,518,017. FIT. INT. CL. 41. (U.S. CLS. 100, 101 AND 107). REG. 12-11-2001.
- 2,518,097. PHARMASSURE. INT. CL. 5. (U.S. CLS. 6, 18, 44, 46, 51 AND 52). REG. 12-11-2001.
- 2,519,184. THERMASHIELD. INT. CL. 17. (U.S. CLS. 1, 5, 12, 13, 35 AND 50). REG. 12-18-2001.
- 2,519,902. CITY WOK. INT. CL. 42. (U.S. CLS. 100 AND 101). REG. 12-18-2001.
- 2,520,300. BINARY PRAIRIE. INT. CL. 42. (U.S. CLS. 100 AND 101). REG. 12-18-2001.
- 2,521,541. KEA LANI HOTEL AND DESIGN. INT. CL. 42. (U.S. CLS. 100 AND 101). REG. 12-25-2001.
- 2,521,621. BLUE RIBBON PET PRODUCTS AND DESIGN. INT. CL. 35. (U.S. CLS. 100, 101 AND 102). REG. 12-25-2001.
- 2,522,124. CITY OF MIAMISBURG OHIO'S STAR CITY AND DESIGN. INT. CL. 42. (U.S. CLS. 100 AND 101). REG. 12-25-2001.
- 2,522,184. ONCE OVER. INT. CL. 3. (U.S. CLS. 1, 4, 6, 50, 51 AND 52). REG. 12-25-2001.
- 2,522,212. MISCELLANEOUS DESIGN. INT. CL. 35. (U.S. CLS. 100, 101 AND 102). REG. 12-25-2001.
- 2,522,465. WORRYLESS. INT. CL. 42. (U.S. CLS. 100 AND 101). REG. 12-25-2001.
- 2,522,550. JAMESTOWN. INT. CLS. 36 AND 37. (U.S. CLS. 100, 101, 102, 103 AND 106). REG. 12-25-2001.
- 2,522,552. JAMESTOWN AND DESIGN. INT. CLS. 36 AND 37. (U.S. CLS. 100, 101, 102, 103 AND 106). REG. 12-25-2001.
- 2,522,640. KPG. INT. CL. 9. (U.S. CLS. 21, 23, 26, 36 AND 38). REG. 12-25-2001.
- 2,524,203. THE UNBOUND BIBLE. INT. CL. 42. (U.S. CLS. 100 AND 101). REG. 1-1-2002.
- 2,524,653. I.D.NA. INT. CL. 1. (U.S. CLS. 1, 5, 6, 10, 26 AND 46). REG. 1-1-2002.

- 2,524,654. GTG. INT. CL. 1. (U.S. CLS. 1, 5, 6, 10, 26 AND 46). REG. 1-1-2002.
- 2,525,030. SPEEDLINEONLINE. INT. CL. 35. (U.S. CLS. 100, 101 AND 102). REG. 1-1-2002.
- 2,525,224. SV. INT. CL. 33. (U.S. CLS. 47 AND 49). REG. 1-1-2002.
- 2,525,294. ULTIMATE BEACH SUNTANNING. INT. CL. 42. (U.S. CLS. 100 AND 101). REG. 1-1-2002.
- 2,527,005. BE FIRE SAFETY SMART, STOP FIRES BEFORE THEY START!. INT. CL. 42. (U.S. CLS. 100 AND 101). REG. 1-8-2002.
- 2,527,042. FIORENTINO. INT. CL. 22. (U.S. CLS. 1, 2, 7, 19, 22, 42 AND 50). REG. 1-8-2002.
- 2,527,216. NCATE. INT. CLS. 16 AND 41. (U.S. CLS. 2, 5, 22, 23, 29, 37, 38, 50, 100, 101 AND 107). REG. 1-8-2002.
- 2,527,368. MISCELLANEOUS DESIGN. INT. CL. 42. (U.S. CLS. 100 AND 101). REG. 1-8-2002.
- 2,527,839. ARISA. INT. CL. 30. (U.S. CL. 46). REG. 1-8-2002.
- 2,528,153. CROWN CHEF. INT. CL. 11 ONLY. (U.S. CLS. 13, 21, 23, 31 AND 34). REG. 1-8-2002.
- 2,529,592. RUBEN'S EMPANADAS. INT. CL. 30. (U.S. CL. 46). REG. 1-15-2002.
- 2,529,730. FTI FLOW TECHNOLOGY. INT. CL. 9. (U.S. CLS. 21, 23, 26, 36 AND 38). REG. 1-15-2002.
- 2,529,972. MINIPLAN. INT. CL. 35. (U.S. CLS. 100, 101 AND 102). REG. 1-15-2002.
- 2,530,124. LEROY HILL COFFEE. INT. CL. 30. (U.S. CL. 46). REG. 1-15-2002.
- 2,530,179. TOM'S #1. INT. CL. 42. (U.S. CLS. 100 AND 101). REG. 1-15-2002.
- 2,530,216. ASTRO INN. INT. CL. 42. (U.S. CLS. 100 AND 101). REG. 1-15-2002.
- 2,530,459. SWISSTEK. INT. CL. 14. (U.S. CLS. 2, 27, 28 AND 50). REG. 1-15-2002.
- 2,530,589. SHARKHEADS. INT. CL. 35. (U.S. CLS. 100, 101 AND 102). REG. 1-15-2002.
- 2,530,851. FASTFRAME. INT. CL. 9. (U.S. CLS. 21, 23, 26, 36 AND 38). REG. 1-15-2002.
- 2,532,515. CELTICS AND DESIGN. INT. CL. 41. (U.S. CLS. 100, 101 AND 107). REG. 1-22-2002.
- 2,532,833. ZERORISK HIRING SYSTEM. INT. CL. 35. (U.S. CLS. 100, 101 AND 102). REG. 1-22-2002.
- 2,533,250. DRAXIS PHARMA. INT. CLS. 35, 39, 40 AND 42. (U.S. CLS. 100, 101, 102, 103, 105 AND 106). REG. 1-29-2002.
- 2,533,308. LIQUID CORE. INT. CL. 11. (U.S. CLS. 13, 21, 23, 31 AND 34). REG. 1-29-2002.
- 2,533,319. FUTURE OF HEALTH TECHNOLOGY SUMMIT. INT. CL. 41. (U.S. CLS. 100, 101 AND 107). REG. 1-29-2002.
- 2,534,290. SDI. INT. CL. 42. (U.S. CLS. 100 AND 101). REG. 1-29-2002.
- 2,534,613. RINGOR. INT. CLS. 18, 21, 25 AND 28. (U.S. CLS. 1, 2, 3, 13, 22, 23, 29, 30, 33, 38, 39, 40, 41 AND 50). REG. 1-29-2002.
- 2,535,694. OPTICHEM (STYLIZED). INT. CL. 9. (U.S. CLS. 21, 23, 26, 36 AND 38). REG. 2-5-2002.
- 2,536,353. DOWNTOWNER. INT. CL. 30. (U.S. CL. 46). REG. 2-5-2002.
- 2,536,401. GALAXY. INT. CL. 9. (U.S. CLS. 21, 23, 26, 36 AND 38). REG. 2-5-2002.
- 2,536,604. MENU ESSENTIALS. INT. CL. 42. (U.S. CLS. 100 AND 101). REG. 2-5-2002.
- 2,536,618. W AND DESIGN. INT. CL. 35. (U.S. CLS. 100, 101 AND 102). REG. 2-5-2002.
- 2,536,696. NATRATASTE. INT. CL. 30. (U.S. CL. 46). REG. 2-5-2002.
- 2,537,000. NI STEEL. INT. CLS. 35 AND 40. (U.S. CLS. 100, 101, 102, 103 AND 106). REG. 2-5-2002.
- 2,537,533. COVENANT TRUST COMPANY. INT. CL. 35. (U.S. CLS. 100, 101 AND 102). REG. 2-12-2002.
- 2,537,539. CHEMSDS+. INT. CL. 9. (U.S. CLS. 21, 23, 26, 36 AND 38). REG. 2-12-2002.
- 2,537,955. PORTLAND STATE UNIVERSITY. INT. CL. 41. (U.S. CLS. 100, 101 AND 107). REG. 2-12-2002.
- 2,538,026. INAVISIS. INT. CLS. 36 AND 42. (U.S. CLS. 100, 101 AND 102). REG. 2-12-2002.
- 2,538,027. INAVISIS AND DESIGN. INT. CLS. 36 AND 42. (U.S. CLS. 100, 101 AND 102). REG. 2-12-2002.
- 2,538,250. PROTENTIAL. INT. CL. 35. (U.S. CLS. 100, 101 AND 102). REG. 2-12-2002.
- 2,538,351. HOW COOL IS HOCKEY. INT. CL. 41. (U.S. CLS. 100, 101 AND 107). REG. 2-12-2002.
- 2,538,518. TRIANGLE TOWN CENTER. INT. CL. 37. (U.S. CLS. 100, 103 AND 106). REG. 2-12-2002.
- 2,538,624. O' LAD. INT. CLS. 35 AND 42. (U.S. CLS. 100, 101 AND 102). REG. 2-12-2002.
- 2,539,036. KIDSTUFF PUBLIC RELATIONS. INT. CL. 35. (U.S. CLS. 100, 101 AND 102). REG. 2-19-2002.
- 2,539,051. ENERGYNET.COM. INT. CL. 35. (U.S. CLS. 100, 101 AND 102). REG. 2-19-2002.
- 2,539,154. Q CLEAN. INT. CL. 5. (U.S. CLS. 6, 18, 44, 46, 51 AND 52). REG. 2-19-2002.
- 2,539,214. SHORE PAC. INT. CL. 1. (U.S. CLS. 1, 5, 6, 10, 26 AND 46). REG. 2-19-2002.
- 2,539,497. WHITE MOUNTAIN LAND COMPANY. INT. CL. 36. (U.S. CLS. 100, 101 AND 102). REG. 2-19-2002.
- 2,539,504. COOL CITRUS BASIL. INT. CL. 3 ONLY. (U.S. CLS. 1, 4, 6, 50, 51 AND 52). REG. 2-19-2002.
- 2,539,816. CPAP PRO. INT. CL. 10. (U.S. CLS. 26, 39 AND 44). REG. 2-19-2002.
- 2,539,845. REDVECTOR. INT. CL. 41. (U.S. CLS. 100, 101 AND 107). REG. 2-19-2002.
- 2,539,899. FOX 1 FINANCIAL. INT. CL. 36. (U.S. CLS. 100, 101 AND 102). REG. 2-19-2002.
- 2,540,174. MISSION STAY FRESH PACK AND DESIGN. INT. CL. 30. (U.S. CL. 46). REG. 2-19-2002.
- 2,540,313. FIELD TRIAL AND DESIGN. INT. CL. 31. (U.S. CLS. 1 AND 46). REG. 2-19-2002.
- 2,540,388. MISCELLANEOUS DESIGN. INT. CL. 42. (U.S. CLS. 100 AND 101). REG. 2-19-2002.
- 2,540,632. BANATROL. INT. CL. 5. (U.S. CLS. 6, 18, 44, 46, 51 AND 52). REG. 2-19-2002.
- 2,540,723. LAUGHING SKULL AND DESIGN. INT. CL. 32. (U.S. CLS. 45, 46 AND 48). REG. 2-19-2002.
- 2,540,815. AKHTAMAR. INT. CL. 33. (U.S. CLS. 47 AND 49). REG. 2-19-2002.
- 2,540,934. ROTISSERIE EXPRESS. INT. CL. 11. (U.S. CLS. 13, 21, 23, 31 AND 34). REG. 2-19-2002.
- 2,540,938. UNIWEAR. INT. CLS. 9 AND 25. (U.S. CLS. 21, 22, 23, 26, 36, 38 AND 39). REG. 2-19-2002.
- 2,541,273. FIREHAWK PVS. INT. CL. 12. (U.S. CLS. 19, 21, 23, 31, 35 AND 44). REG. 2-19-2002.
- 2,541,350. SECURE COMFORT AND DESIGN. INT. CL. 35. (U.S. CLS. 100, 101 AND 102). REG. 2-19-2002.
- 2,541,578. MULTIKRAFT. INT. CL. 16. (U.S. CLS. 2, 5, 22, 23, 29, 37, 38 AND 50). REG. 2-19-2002.
- 2,541,762. THE HOME AUTHORITY. INT. CL. 42. (U.S. CLS. 100 AND 101). REG. 2-19-2002.
- 2,541,893. INDEPENDENT HEALTHCARE PROPERTIES. INT. CLS. 36 AND 37. (U.S. CLS. 100, 101, 102, 103 AND 106). REG. 2-19-2002.
- 2,542,020. NAVIGATOR. INT. CL. 7. (U.S. CLS. 13, 19, 21, 23, 31, 34 AND 35). REG. 2-26-2002.
- 2,542,130. AMERICANGAS AND DESIGN. INT. CL. 16. (U.S. CLS. 2, 5, 22, 23, 29, 37, 38 AND 50). REG. 2-26-2002.
- 2,542,742. POSTALMATE. INT. CL. 9. (U.S. CLS. 21, 23, 26, 36 AND 38). REG. 2-26-2002.
- 2,543,006. EXPERIENCE LIFE THE SIESTA WAY. INT. CL. 36. (U.S. CLS. 100, 101 AND 102). REG. 2-26-2002.

\* \* \* \* \*

# TRADEMARK REGISTRATIONS CANCELED

The designation "U.S. Cl." appearing in this section refers to the U.S. class in effect prior to Sep. 1, 1973 rather than the international class which applies to applications filed on or after that date. For adoption of international classification see notice in the OFFICIAL GAZETTE of Jun. 26, 1973 (911 O.G. TM 210).

## SECTION 7(D)

- 691,063. MAVERICK. U.S. CL. 107. REG. 1-5-1960.  
803,183. SUNDAE TWIST (STYLIZED). U.S. CL. 46. REG. 2-1-1966.  
1,140,870. MARSHMALLOWS. INT. CL. 25. REG. 10-28-1980.  
1,578,621. VOYAGER AND DESIGN. INT. CL. 7. REG. 1-23-1990.  
1,630,385. CAPPELLI & COMPANY. INT. CL. 41. REG. 1-1-1991.  
1,759,846. RODALE'S SCUBA DIVING. INT. CL. 16. REG. 3-23-1993.  
2,389,336. IFILM. INT. CL. 41. REG. 9-26-2000.  
2,526,930. BEJA. INT. CL. 3. REG. 1-8-2002.  
2,893,732. LIDIA'S REGIONAL ITALIAN FLAVORS. INT. CL. 30. REG. 10-12-2004.  
2,904,564. SAM STANDARD CHARACTER MARK. INT. CL. 9. REG. 11-23-2004.  
2,906,892. TENSION. INT. CL. 25. REG. 11-30-2004.  
2,911,321. IFILM. INT. CLS. 9 AND 16. REG. 12-14-2004.  
2,918,027. FINESSE. INT. CL. 33. REG. 1-11-2005.  
2,932,277. LIL-LETS. INT. CL. 5. REG. 3-15-2005.  
3,034,485. RHINO BOND STANDARD CHARACTER MARK. INT. CL. 1. REG. 12-27-2005.  
3,042,607. WHAT HAPPENS IN NEW ORLEANS STAYS IN NEW ORLEANS STANDARD CHARACTER MARK. INT. CL. 25. REG. 1-10-2006.  
3,105,175. BRASH AND DESIGN. INT. CL. 25. REG. 6-13-2006.  
3,136,649. BRIGHT NOW STANDARD CHARACTER MARK. INT. CL. 3. REG. 8-29-2006.  
3,142,994. WIZARD STANDARD CHARACTER MARK. INT. CL. 16. REG. 9-12-2006.  
3,151,646. SPELLBINDERS STANDARD CHARACTER MARK. INT. CL. 8. REG. 10-3-2006.  
3,188,033. PATIENT'S PAL STANDARD CHARACTER MARK. INT. CL. 10. REG. 12-19-2006.  
3,210,406. HRRO (STYLIZED). INT. CL. 36. REG. 2-20-2007.  
3,276,409. LE BON VIN DE LA NAPA VALLEY STANDARD CHARACTER MARK. INT. CL. 33. REG. 8-7-2007.  
3,281,409. CITI-MOBILE STANDARD CHARACTER MARK. INT. CL. 35. REG. 8-21-2007.  
3,291,144. GRILLARDIN STANDARD CHARACTER MARK. INT. CLS. 16, 41 AND 43. REG. 9-11-2007.  
3,291,145. DAME DE LA CHAÎNE STANDARD CHARACTER MARK. INT. CLS. 16, 41 AND 43. REG. 9-11-2007.  
3,291,146. MISCELLANEOUS DESIGN. INT. CLS. 16, 41 AND 43. REG. 9-11-2007.  
3,291,147. BAILLIAGE STANDARD CHARACTER MARK. INT. CLS. 16, 41 AND 43. REG. 9-11-2007.  
3,291,148. BAILLI STANDARD CHARACTER MARK. INT. CLS. 16, 41 AND 43. REG. 9-11-2007.  
3,291,859. MAXIM STANDARD CHARACTER MARK. INT. CL. 9. REG. 9-11-2007.  
3,293,438. ROLLOS STANDARD CHARACTER MARK. INT. CL. 31. REG. 9-18-2007.  
3,294,218. ECHANSON STANDARD CHARACTER MARK. INT. CLS. 16, 41 AND 43. REG. 9-18-2007.  
3,295,448. MAXIM (STYLIZED). INT. CL. 9. REG. 9-18-2007.  
3,298,236. SENECHAL STANDARD CHARACTER MARK. INT. CLS. 16, 41 AND 43. REG. 9-25-2007.  
3,311,930. FORT DATA STANDARD CHARACTER MARK. INT. CL. 35. REG. 10-16-2007.  
3,314,892. JULEP STANDARD CHARACTER MARK. INT. CL. 16. REG. 10-16-2007.  
3,332,188. NUTRACUT STANDARD CHARACTER MARK. INT. CL. 5. REG. 11-6-2007.  
3,356,083. GILDAN ACTIVEWEAR ULTRA BLEND AND DESIGN. INT. CL. 25. REG. 12-18-2007.  
3,374,752. VALLEY EYEDOL (STYLIZED). INT. CL. 41. REG. 1-29-2008.  
3,409,321. ARGENTIER STANDARD CHARACTER MARK. INT. CLS. 16, 41 AND 43. REG. 4-8-2008.  
3,450,911. S AND DESIGN. INT. CLS. 25, 38 AND 41. REG. 6-17-2008.  
3,458,542. VINTAGE MODERN STANDARD CHARACTER MARK. INT. CLS. 8, 16, 26 AND 28. REG. 7-1-2008.  
3,462,430. CHAMBELLAN STANDARD CHARACTER MARK. INT. CLS. 16, 41 AND 43. REG. 7-8-2008.  
3,464,016. SPEED BRIGADE STANDARD CHARACTER MARK. INT. CLS. 25, 38 AND 41. REG. 7-8-2008.  
3,500,325. SIMPLE DELIGHTS STANDARD CHARACTER MARK. INT. CL. 29. REG. 9-9-2008.  
3,532,880. SCRIPTS AND DESIGN. INT. CL. 43. REG. 11-18-2008.  
3,535,112. CU-AVANA INTENSO STANDARD CHARACTER MARK. INT. CL. 34. REG. 11-18-2008.  
3,598,015. TTS (STYLIZED). INT. CL. 39. REG. 3-31-2009.  
3,628,947. AFTER 911, CALL 411 STANDARD CHARACTER MARK. INT. CL. 42. REG. 5-26-2009.  
3,642,048. IFILM STANDARD CHARACTER MARK. INT. CL. 41. REG. 6-23-2009.  
3,649,780. LAUREL SPRINGS SCHOOL STANDARD CHARACTER MARK. INT. CL. 41. REG. 7-7-2009.  
3,672,322. TRUCK SPEAK P&L STANDARD CHARACTER MARK. INT. CLS. 35 AND 36. REG. 8-25-2009.  
3,724,676. NUMBER (N)INE TAKAHIRO MIYASHITA AND DESIGN. INT. CL. 25. REG. 12-15-2009.  
3,727,175. JAGUAR KING THE KING OF SOUNDS AND DESIGN. INT. CL. 9. REG. 12-22-2009.  
3,749,250. CAFE VEEPRESS STANDARD CHARACTER MARK. INT. CL. 30. REG. 2-16-2010.  
3,751,124. THE LEARNING SPRINGS STANDARD CHARACTER MARK. INT. CL. 41. REG. 2-23-2010.  
3,764,071. CHASE CREEK STANDARD CHARACTER MARK. INT. CL. 33. REG. 3-23-2010.  
3,770,283. AGELESS FANTASY STANDARD CHARACTER MARK. INT. CL. 3. REG. 4-6-2010.  
3,788,729. 1800 STANDARD CHARACTER MARK. INT. CL. 32. REG. 5-11-2010.  
3,805,797. AG AUDITGUARD AND DESIGN. INT. CL. 35. REG. 6-22-2010.  
3,808,242. FAMILY FINANCIAL CONFIDANT STANDARD CHARACTER MARK. INT. CLS. 35 AND 36. REG. 6-22-2010.  
3,821,941. ZAKUMI AND DESIGN. INT. CL. 30. REG. 7-20-2010.  
3,837,418. RELIEF RX STANDARD CHARACTER MARK. INT. CL. 3. REG. 8-24-2010.  
3,860,707. STOP STARVING YOUR BRAIN STANDARD CHARACTER MARK. INT. CL. 5. REG. 10-12-2010.

- 3,860,708. HAPPY . CALM . FOCUSED STANDARD CHARACTER MARK. INT. CL. 5. REG. 10-12-2010.
- 3,861,250. LUMETA STANDARD CHARACTER MARK. INT. CL. 19. REG. 10-12-2010.
- 3,906,293. COLORBOOST STANDARD CHARACTER MARK. INT. CL. 3. REG. 1-18-2011.
- 
- SECTION 8**
- 512,523. ANODEX AND DESIGN. U.S. CL. 4. REG. 7-19-1949.
- 678,718. MACRO (STYLIZED). U.S. CL. 6. REG. 5-19-1959.
- 696,323. EXCEDRIN. U.S. CL. 18. REG. 4-19-1960.
- 861,678. TRACTION TORQUE (STYLIZED). U.S. CL. 35. REG. 12-10-1968.
- 893,563. EXCEDRIN P.M.. U.S. CL. 18. REG. 6-30-1970.
- 1,149,605. SIG AND DESIGN. INT. CL. 12 ONLY. REG. 3-31-1981.
- 1,426,480. PULSE PLUS. INT. CL. 11. REG. 1-27-1987.
- 1,468,193. PUREFLOW. INT. CL. 11. REG. 12-8-1987.
- 1,528,518. US ALFALFA THE PREMIUM QUALITY HAY FOR HORSES AND DESIGN. INT. CL. 31. REG. 3-7-1989.
- 1,549,581. DESIGN STREAM. INT. CL. 42. REG. 7-25-1989.
- 1,558,931. THUNDER. INT. CL. 12. REG. 10-3-1989.
- 1,577,416. QMED (STYLIZED). INT. CLS. 9 AND 10. REG. 1-16-1990.
- 1,605,434. COMPOMOTIVE. INT. CL. 12. REG. 7-10-1990.
- 1,607,062. ENZO TREVI VERONA. INT. CLS. 3 AND 42. REG. 7-24-1990.
- 1,607,475. PRIME USA. INT. CLS. 18, 20 AND 25. REG. 7-24-1990.
- 1,635,682. TRANSAMERICA (STYLIZED). INT. CLS. 35, 37, 39 AND 41 ONLY. REG. 2-19-1991.
- 1,636,109. COLE HAAN. INT. CL. 14 ONLY. REG. 2-26-1991.
- 1,668,253. LEONORE DOSKOW. INT. CL. 8 ONLY. REG. 12-17-1991.
- 1,902,345. FIT AMERICA. INT. CL. 5. REG. 7-4-1995.
- 1,906,361. OBJECTBENCH. INT. CL. 9. REG. 7-18-1995.
- 1,915,553. CORPORATE SCENES. INT. CL. 41. REG. 8-29-1995.
- 2,000,386. COLOR REVERSE. INT. CL. 1. REG. 9-10-1996.
- 2,024,206. T.R.E.A.T.S. AND DESIGN. INT. CL. 25. REG. 12-17-1996.
- 2,027,606. TOMBSTONE FOR ONE DEEP DISH. INT. CL. 30. REG. 12-31-1996.
- 2,028,350. TYPE '80. INT. CL. 9. REG. 1-7-1997.
- 2,063,419. RECRUIT AMERICA. INT. CL. 16. REG. 5-20-1997.
- 2,072,301. FISHTOWN. INT. CL. 1. REG. 6-17-1997.
- 2,100,038. FRIENDSHIP CLUB AND DESIGN. INT. CLS. 14 AND 28. REG. 9-23-1997.
- 2,146,341. ROOM TO GROW. INT. CL. 25. REG. 3-24-1998.
- 2,169,908. DAL TILE AND DESIGN. INT. CL. 19. REG. 6-30-1998.
- 2,177,852. THE FAMILY VAN. INT. CL. 42. REG. 8-4-1998.
- 2,205,256. ECONO-FILL. INT. CL. 19. REG. 11-24-1998.
- 2,209,096. ZAP MAN. INT. CL. 36. REG. 12-8-1998.
- 2,236,060. BJ BLITZ BLACKJACK AND DESIGN. INT. CL. 41. REG. 3-30-1999.
- 2,255,546. JURISPHERE. INT. CL. 35. REG. 6-22-1999.
- 2,263,713. IMMORTAL COSMETICS BY GLEN BADESSA AND DESIGN. INT. CL. 3. REG. 7-20-1999.
- 2,283,633. MISCELLANEOUS DESIGN. INT. CL. 14. REG. 10-5-1999.
- 2,299,845. FIELDS MATTERS. INT. CL. 16 ONLY. REG. 12-14-1999.
- 2,310,835. BE A PHANTOM WARRIOR OR BECOME A TARGET!. INT. CL. 11. REG. 1-25-2000.
- 2,318,938. JYE'S. INT. CL. 14. REG. 2-15-2000.
- 2,319,616. PANMEDIA. INT. CL. 35. REG. 2-15-2000.
- 2,332,763. MOVE IT. INT. CL. 9. REG. 3-21-2000.
- 2,334,300. VIRTUAL MUSIC. INT. CL. 9. REG. 3-28-2000.
- 2,338,981. CONDOR. INT. CL. 12. REG. 4-4-2000.
- 2,347,192. @ SPINFISH WEB AND DESIGN. INT. CLS. 35 AND 42. REG. 5-2-2000.
- 2,354,705. MISCELLANEOUS DESIGN. INT. CLS. 9 AND 42. REG. 6-6-2000.
- 2,367,314. SUCCESSWARE. INT. CL. 9. REG. 7-18-2000.
- 2,367,317. BIB. INT. CL. 16. REG. 7-18-2000.
- 2,367,324. STANDARD MORTGAGE. INT. CL. 36. REG. 7-18-2000.
- 2,367,336. NIELSEN MEDIA RESEARCH. INT. CL. 16. REG. 7-18-2000.
- 2,367,353. REALITY (STYLIZED). INT. CL. 15. REG. 7-18-2000.
- 2,367,358. WILD CALIFORNIA. INT. CL. 41. REG. 7-18-2000.
- 2,367,367. SURESOURCE. INT. CL. 35. REG. 7-18-2000.
- 2,367,369. MISCELLANEOUS DESIGN. INT. CL. 20. REG. 7-18-2000.
- 2,367,392. 1-800-GATEWAY. INT. CL. 35. REG. 7-18-2000.
- 2,367,399. CITY CASUALS. INT. CL. 25. REG. 7-18-2000.
- 2,367,411. GITA. INT. CLS. 41 AND 42. REG. 7-18-2000.
- 2,367,419. IMEX INTERNATIONAL MAIL EXPRESS, INC. AND DESIGN. INT. CLS. 35 AND 39. REG. 7-18-2000.
- 2,367,433. WHERE THE BIG BOYS BUY THEIR BIG TOYS TOOLS AND DESIGN. INT. CL. 37. REG. 7-18-2000.
- 2,367,435. AMERICA'S CARPET GALLERY. INT. CLS. 20, 25 AND 27. REG. 7-18-2000.
- 2,367,442. GENERATIONS AND DESIGN. INT. CL. 20. REG. 7-18-2000.
- 2,367,444. HOMEOCOCCINUM. INT. CL. 5. REG. 7-18-2000.
- 2,367,469. AFFILIATED NETWORK SERVICES. INT. CLS. 35 AND 36. REG. 7-18-2000.
- 2,367,499. PLB AND DESIGN. INT. CL. 16. REG. 7-18-2000.
- 2,367,513. HFV. INT. CL. 7. REG. 7-18-2000.
- 2,367,518. A. HAYS TOWN. INT. CL. 42. REG. 7-18-2000.
- 2,367,520. BUTCH HARMON'S GOLF MANAGER. INT. CL. 9. REG. 7-18-2000.
- 2,367,526. TOM TOM TAILOR (STYLIZED). INT. CL. 25. REG. 7-18-2000.
- 2,367,527. THE DREAM BY CLAYTON AND DESIGN. INT. CL. 35. REG. 7-18-2000.
- 2,367,533. MISCELLANEOUS DESIGN. INT. CL. 12. REG. 7-18-2000.
- 2,367,535. ENERESSENCE. INT. CL. 5. REG. 7-18-2000.
- 2,367,538. NATIONSRENT AND DESIGN. INT. CLS. 35 AND 37. REG. 7-18-2000.
- 2,367,540. RESTAURANT TOUGH. INT. CL. 9. REG. 7-18-2000.
- 2,367,562. INDEPENDENCE SERIES AND DESIGN. INT. CL. 36. REG. 7-18-2000.
- 2,367,575. VIRTUO. INT. CL. 9. REG. 7-18-2000.
- 2,367,580. ALDANAL. INT. CL. 42. REG. 7-18-2000.
- 2,367,586. MISCELLANEOUS DESIGN. INT. CL. 25. REG. 7-18-2000.
- 2,367,595. HYPERTOUCHE. INT. CL. 42. REG. 7-18-2000.
- 2,367,599. CENTURION. INT. CL. 7. REG. 7-18-2000.
- 2,367,600. COLORTAC. INT. CL. 16. REG. 7-18-2000.
- 2,367,605. MW AND DESIGN. INT. CL. 19. REG. 7-18-2000.
- 2,367,606. COMMUNITY UNITED AGAINST VIOLENCE. INT. CL. 42. REG. 7-18-2000.
- 2,367,621. SUNCOM. INT. CL. 38. REG. 7-18-2000.
- 2,367,636. SERVING THE SEA SERVICES AND DESIGN. INT. CL. 42. REG. 7-18-2000.
- 2,367,638. PIECES OF EIGHT CONTINUUM. INT. CL. 42. REG. 7-18-2000.
- 2,367,640. OPTITURN. INT. CL. 9. REG. 7-18-2000.
- 2,367,643. TI.HEAT. INT. CL. 28. REG. 7-18-2000.
- 2,367,644. SLIPP-NOTT. INT. CL. 27. REG. 7-18-2000.
- 2,367,649. GUIDANT. INT. CL. 42. REG. 7-18-2000.
- 2,367,650. WEAR IN THE WATER. INT. CL. 25. REG. 7-18-2000.
- 2,367,651. ASSAULT. INT. CL. 12. REG. 7-18-2000.
- 2,367,652. RAZOR SAVER. INT. CL. 8. REG. 7-18-2000.
- 2,367,658. ERT. INT. CL. 35. REG. 7-18-2000.
- 2,367,665. LIVE WHERE YOU PLAY. INT. CL. 36. REG. 7-18-2000.
- 2,367,671. PROSTASOY. INT. CL. 5. REG. 7-18-2000.

- 2,367,684. LION. INT. CL. 3. REG. 7-18-2000.  
 2,367,689. NATURESOFT. INT. CL. 3. REG. 7-18-2000.  
 2,367,698. CONTROL VENT. INT. CL. 6. REG. 7-18-2000.  
 2,367,709. MISCELLANEOUS DESIGN. INT. CL. 7. REG. 7-18-2000.  
 2,367,719. WHERE EVERY BITE IS JUST RIPE. INT. CL. 42. REG. 7-18-2000.  
 2,367,720. TAKE WEIGHT GUIDE. INT. CL. 16. REG. 7-18-2000.  
 2,367,728. MENT-A-TECH. INT. CLS. 41 AND 42. REG. 7-18-2000.  
 2,367,750. P.I.C.TOONS AND DESIGN. INT. CL. 16. REG. 7-18-2000.  
 2,367,752. SALLIEMAE LAUREATE AND DESIGN. INT. CL. 36. REG. 7-18-2000.  
 2,367,757. KFXO. INT. CL. 38. REG. 7-18-2000.  
 2,367,767. DARLEY. INT. CL. 7. REG. 7-18-2000.  
 2,367,787. AUDIOWEB. INT. CLS. 35, 38 AND 42. REG. 7-18-2000.  
 2,367,798. SCORETRAC. INT. CL. 9. REG. 7-18-2000.  
 2,367,806. FREEDOM. INT. CL. 9. REG. 7-18-2000.  
 2,367,814. BASIS TECHLIB. INT. CL. 9. REG. 7-18-2000.  
 2,367,826. CAREERDESIGNS UNLIMITED. INT. CL. 42. REG. 7-18-2000.  
 2,367,830. VISIONLS. INT. CL. 9. REG. 7-18-2000.  
 2,367,840. ECO CLEAN AND DESIGN. INT. CL. 39. REG. 7-18-2000.  
 2,367,841. ECO CLEAN AND DESIGN. INT. CL. 39. REG. 7-18-2000.  
 2,367,842. SYSTRONIX. INT. CL. 9. REG. 7-18-2000.  
 2,367,849. VIRTUAL AVENUE FREE VIRTUAL DOMAIN HOSTNG AND DESIGN. INT. CL. 42. REG. 7-18-2000.  
 2,367,852. SPIDER CLIP. INT. CL. 26. REG. 7-18-2000.  
 2,367,856. MISCELLANEOUS DESIGN. INT. CLS. 9 AND 16. REG. 7-18-2000.  
 2,367,868. T3 SYSTEM. INT. CL. 19. REG. 7-18-2000.  
 2,367,881. THE SHADE BUTLER. INT. CL. 20. REG. 7-18-2000.  
 2,367,885. NATIONAL SPEAKERS ASSOCIATION NSA CERTIFIED SPEAKING PROFESSIONAL CSP AND DESIGN. U.S. CL. 200. REG. 7-18-2000.  
 2,367,892. MUSCATO AND DESIGN. INT. CLS. 9 AND 42. REG. 7-18-2000.  
 2,367,893. MUSCATO. INT. CLS. 9 AND 42. REG. 7-18-2000.  
 2,367,897. CELEBRATE VIRGINIA AMERICA'S DESTINATION. INT. CL. 35. REG. 7-18-2000.  
 2,367,904. MISS MONEYPENNY'S. INT. CLS. 9, 25, 35, 41 AND 42. REG. 7-18-2000.  
 2,367,913. CUSTOM FRAME THE BEAUTY OF YOUR HOME. INT. CL. 20. REG. 7-18-2000.  
 2,367,919. INSIDER. INT. CL. 16. REG. 7-18-2000.  
 2,367,921. BVG BAUER VEHICLE GEAR AND DESIGN. INT. CL. 12. REG. 7-18-2000.  
 2,367,922. F AND DESIGN. INT. CL. 42. REG. 7-18-2000.  
 2,367,925. GROUNDHOG JOB SHADOW DAY! AND DESIGN. INT. CL. 41. REG. 7-18-2000.  
 2,367,935. CAPETOWN-RIO. INT. CL. 41. REG. 7-18-2000.  
 2,367,966. NETRO CITY. INT. CL. 42. REG. 7-18-2000.  
 2,367,979. BORDOFINO (STYLIZED). INT. CL. 19. REG. 7-18-2000.  
 2,367,982. CRAZY HORSE. INT. CL. 18. REG. 7-18-2000.  
 2,367,991. MISCELLANEOUS DESIGN. INT. CL. 6. REG. 7-18-2000.  
 2,367,992. AFTERBURNER. INT. CL. 5. REG. 7-18-2000.  
 2,368,006. DESIGN FACTORY INTERNATIONAL. INT. CL. 42. REG. 7-18-2000.  
 2,368,019. BANKTEAM AND DESIGN. INT. CLS. 9 AND 16. REG. 7-18-2000.  
 2,368,021. AGRICORE, INC.. INT. CL. 35. REG. 7-18-2000.  
 2,368,027. ACCU-PRODUCTS. INT. CL. 9. REG. 7-18-2000.  
 2,368,033. GRAVITY. INT. CL. 9. REG. 7-18-2000.  
 2,368,034. AMPHION (STYLIZED). INT. CL. 16. REG. 7-18-2000.  
 2,368,043. BIG BROTHERS BIG SISTERS INTERNATIONAL AND DESIGN. INT. CL. 42. REG. 7-18-2000.  
 2,368,048. WOW SELECT-EDUCATION IN EXCELLENCE. INT. CLS. 16 AND 41. REG. 7-18-2000.  
 2,368,049. WOW. INT. CL. 41. REG. 7-18-2000.  
 2,368,050. WOW SELECT. INT. CL. 41. REG. 7-18-2000.  
 2,368,053. FIREPAGE. INT. CL. 38. REG. 7-18-2000.  
 2,368,061. LIFE IS A BALL. INT. CL. 16. REG. 7-18-2000.  
 2,368,069. DRKOOOP.COM. INT. CLS. 35, 36 AND 42. REG. 7-18-2000.  
 2,368,080. SINBAD AND DESIGN. INT. CL. 11. REG. 7-18-2000.  
 2,368,081. SINBAD AND DESIGN. INT. CL. 9. REG. 7-18-2000.  
 2,368,082. SINBAD. INT. CL. 9. REG. 7-18-2000.  
 2,368,083. SINBAD. INT. CL. 11. REG. 7-18-2000.  
 2,368,088. S AND DESIGN. INT. CL. 37. REG. 7-18-2000.  
 2,368,090. MISCELLANEOUS DESIGN. INT. CL. 39. REG. 7-18-2000.  
 2,368,093. AFTER THE "INC." DRIES. INT. CLS. 9 AND 16. REG. 7-18-2000.  
 2,368,102. LEARNTOUSA AND DESIGN. INT. CL. 9. REG. 7-18-2000.  
 2,368,112. COLOR KINETICS AND DESIGN. INT. CLS. 9 AND 11. REG. 7-18-2000.  
 2,368,120. HOW TOWN. INT. CL. 16. REG. 7-18-2000.  
 2,368,127. TXO2 (STYLIZED). INT. CL. 10. REG. 7-18-2000.  
 2,368,128. TX O2 AND DESIGN. INT. CL. 10. REG. 7-18-2000.  
 2,368,130. INOTEC. INT. CL. 35. REG. 7-18-2000.  
 2,368,143. URGENT MONEY SERVICE. INT. CL. 36. REG. 7-18-2000.  
 2,368,144. VERMONT GOLF. INT. CL. 16. REG. 7-18-2000.  
 2,368,153. NATIONAL ASSOCIATION OF RECORDING MERCHANTISERS. U.S. CL. 200. REG. 7-18-2000.  
 2,368,154. NARM. U.S. CL. 200. REG. 7-18-2000.  
 2,368,155. SAVING THE WORLD'S WATER. ONE TAP AT A TIME. INT. CLS. 37, 39 AND 42. REG. 7-18-2000.  
 2,368,157. THE BENEFITS GROUP AND DESIGN. INT. CL. 35. REG. 7-18-2000.  
 2,368,166. AMERITOR FINANCIAL CORPORATION. INT. CL. 36. REG. 7-18-2000.  
 2,368,171. NEW JERSEY OPTOMETRIC ASSOCIATION. INT. CL. 42. REG. 7-18-2000.  
 2,368,175. BAMP. INT. CLS. 9, 35 AND 42. REG. 7-18-2000.  
 2,368,176. AESTHETIC REJUVENATION CENTER AND DESIGN. INT. CL. 42. REG. 7-18-2000.  
 2,368,184. MATCH UP. INT. CLS. 3 AND 5. REG. 7-18-2000.  
 2,368,186. SURADO. INT. CLS. 9 AND 42. REG. 7-18-2000.  
 2,368,194. THINK IDEAS. INT. CL. 35. REG. 7-18-2000.  
 2,368,204. MISCELLANEOUS DESIGN. INT. CL. 42. REG. 7-18-2000.  
 2,368,205. ELOQUENT PHYSICIAN. INT. CL. 9. REG. 7-18-2000.  
 2,368,215. SMOKEY BRAT-DOG. INT. CL. 35. REG. 7-18-2000.  
 2,368,225. MAKE IT SNAPPY. INT. CL. 7. REG. 7-18-2000.  
 2,368,228. PRICE KING. INT. CL. 35. REG. 7-18-2000.  
 2,368,230. DON'T PANIC. INT. CL. 25. REG. 7-18-2000.  
 2,368,231. DOT'Z BAKERY AND DESIGN. INT. CL. 35. REG. 7-18-2000.  
 2,368,237. THE ORIGINAL CASCADE. INT. CL. 25. REG. 7-18-2000.  
 2,368,242. PLAYKIDS U.S.A.. INT. CL. 28. REG. 7-18-2000.  
 2,368,256. BARLEAN'S PURE NATURAL OILS OLD FASHIONED CARE AND DESIGN. INT. CL. 29. REG. 7-18-2000.  
 2,368,267. ITP WORLDWIDE. INT. CL. 35. REG. 7-18-2000.  
 2,368,272. CASSIFFIX. INT. CLS. 1 AND 3. REG. 7-18-2000.  
 2,368,274. THE REALISTICS (STYLIZED). INT. CL. 41. REG. 7-18-2000.  
 2,368,276. FACTORY STRESS. INT. CL. 28. REG. 7-18-2000.  
 2,368,277. BIG CASH BINGO. INT. CLS. 9, 28 AND 41. REG. 7-18-2000.  
 2,368,291. MISCELLANEOUS DESIGN. INT. CL. 36. REG. 7-18-2000.  
 2,368,293. WE CLOBBER BIG CITY PRICES. INT. CLS. 35 AND 37. REG. 7-18-2000.  
 2,368,299. PROGRESSIVE GLASS TECHNOLOGY. INT. CLS. 6 AND 19. REG. 7-18-2000.  
 2,368,305. MAMA'S. INT. CL. 42. REG. 7-18-2000.  
 2,368,310. HANDS HIGH. INT. CL. 9. REG. 7-18-2000.

- 2,368,313. WEB TIDES. INT. CL. 42. REG. 7-18-2000.  
 2,368,315. PHYSIOTOP. INT. CLS. 3 AND 5. REG. 7-18-2000.  
 2,368,326. WORK @ EMPLOYMENTGROUP AND DESIGN. INT. CL. 36. REG. 7-18-2000.  
 2,368,339. ELZA. INT. CL. 41. REG. 7-18-2000.  
 2,368,341. UPRIGHT (STYLIZED). INT. CLS. 6 AND 7. REG. 7-18-2000.  
 2,368,344. MINI-DELITES ESTABLISHED IN 1972 AND DESIGN. INT. CL. 30. REG. 7-18-2000.  
 2,368,345. TRACE OF TIME. INT. CL. 35. REG. 7-18-2000.  
 2,368,349. MER METER. INT. CL. 9. REG. 7-18-2000.  
 2,368,350. STREET & SMITH'S SPORTS BUSINESS INSTITUTE AND DESIGN. INT. CL. 41. REG. 7-18-2000.  
 2,368,360. CALIFORNIA HOME CARE AND DESIGN. INT. CL. 42. REG. 7-18-2000.  
 2,368,366. MISCELLANEOUS DESIGN. INT. CL. 36. REG. 7-18-2000.  
 2,368,374. VERSA-CABINET. INT. CL. 20. REG. 7-18-2000.  
 2,368,376. READY BOX. INT. CL. 9. REG. 7-18-2000.  
 2,368,378. SIMCHARTS BY JEPPESEN. INT. CL. 9. REG. 7-18-2000.  
 2,368,381. OPEN CHANNEL SOLUTIONS AND DESIGN. INT. CL. 35. REG. 7-18-2000.  
 2,368,398. CHARACTER LINKS. INT. CL. 16. REG. 7-18-2000.  
 2,368,399. MISCELLANEOUS DESIGN. INT. CL. 16. REG. 7-18-2000.  
 2,368,404. CITYWIDE PLUMBING\*HEATING\*AIR\*ELECTRICAL AND DESIGN. INT. CL. 37. REG. 7-18-2000.  
 2,368,409. THE KIDS' SIDE. INT. CL. 42. REG. 7-18-2000.  
 2,368,410. MUG PRO. INT. CL. 9. REG. 7-18-2000.  
 2,368,412. KNOX AND DESIGN. INT. CL. 9. REG. 7-18-2000.  
 2,368,415. THE RISK FACTOR AND DESIGN. INT. CL. 16. REG. 7-18-2000.  
 2,368,429. FANSCAN AND DESIGN. INT. CLS. 9 AND 41. REG. 7-18-2000.  
 2,368,438. DAMDIFINO. INT. CL. 16. REG. 7-18-2000.  
 2,368,439. FI THE FOOD INSTITUTE AND DESIGN. INT. CL. 16. REG. 7-18-2000.  
 2,368,440. STEELTREE. INT. CL. 19. REG. 7-18-2000.  
 2,368,450. SAFE-T-BELT. INT. CL. 8. REG. 7-18-2000.  
 2,368,452. EAST PARK AND DESIGN. INT. CL. 5. REG. 7-18-2000.  
 2,368,455. POWER MODULATOR. INT. CL. 12. REG. 7-18-2000.  
 2,368,461. PHO 75. INT. CL. 42. REG. 7-18-2000.  
 2,368,479. LOVING REMINDERS. INT. CL. 16. REG. 7-18-2000.  
 2,368,483. FUTURE TECH AND DESIGN. INT. CLS. 35 AND 41. REG. 7-18-2000.  
 2,368,491. SKYCLIENT. INT. CL. 35. REG. 7-18-2000.  
 2,368,497. RIO NEGRO LODGE. INT. CL. 42. REG. 7-18-2000.  
 2,368,498. ICR INSECT CONTROL & RESEARCH, INC. AND DESIGN. INT. CL. 42. REG. 7-18-2000.  
 2,368,505. CONIX. INT. CL. 9. REG. 7-18-2000.  
 2,368,509. ART BEHIND BARS AND DESIGN. INT. CL. 41. REG. 7-18-2000.  
 2,368,520. FREEDOMWEAR FX PLATE. INT. CL. 6. REG. 7-18-2000.  
 2,368,521. PALENQUE. INT. CL. 31. REG. 7-18-2000.  
 2,368,526. SPEED & JUSTICE FOR ALL. INT. CL. 42. REG. 7-18-2000.  
 2,368,528. TODAY'S WINDOW FASHIONS "AT YESTERDAY'S PRICES" BLINDS VERTICALS SHADES SHUTTERS AND DESIGN. INT. CL. 35. REG. 7-18-2000.  
 2,368,538. BRILLIG PRODUCTIONS AND DESIGN. INT. CL. 41. REG. 7-18-2000.  
 2,368,540. VANN'S AND DESIGN. INT. CL. 35. REG. 7-18-2000.  
 2,368,542. BRENTWOOD. INT. CL. 12. REG. 7-18-2000.  
 2,368,546. QUOTABLES AND DESIGN. INT. CL. 16. REG. 7-18-2000.  
 2,368,547. FLEXIPAC. INT. CL. 10. REG. 7-18-2000.  
 2,368,552. IMPARTS. INT. CL. 35. REG. 7-18-2000.  
 2,368,557. GUARDIAN PLUS. INT. CL. 35. REG. 7-18-2000.  
 2,368,560. TARA VANESSA. INT. CL. 3. REG. 7-18-2000.  
 2,368,564. ITISLAW. INT. CL. 42. REG. 7-18-2000.  
 2,368,613. VINCENT JAMES. INT. CLS. 9 AND 41. REG. 7-18-2000.  
 2,368,618. ASTRA LOGISTICS SERVICES. INT. CL. 39. REG. 7-18-2000.  
 2,368,625. SQUEEZE PLUS. INT. CL. 1. REG. 7-18-2000.  
 2,368,633. TIGERTUNES.COM. INT. CL. 9. REG. 7-18-2000.  
 2,368,636. THE DOMINION SERIES AND DESIGN. INT. CL. 36. REG. 7-18-2000.  
 2,368,637. TRIPLE TRAINER 3. INT. CL. 28. REG. 7-18-2000.  
 2,368,641. CREATIVE SOLUTIONS FOR BUILDING YOUR CHIROPRACTIC PRACTICE. INT. CL. 35. REG. 7-18-2000.  
 2,368,650. KNOWLEDGE THAT HELPS PAY FOR COLLEGE. INT. CL. 36. REG. 7-18-2000.  
 2,368,659. LIQUISIZE. INT. CL. 1. REG. 7-18-2000.  
 2,368,673. GRIDIRON GRUMBLINGS. INT. CL. 42. REG. 7-18-2000.  
 2,368,681. KEEP-IT SAFE. INT. CL. 20. REG. 7-18-2000.  
 2,368,691. WINTEC. INT. CL. 42. REG. 7-18-2000.  
 2,368,708. SIDE BY SIDE FAMILIES. INT. CL. 16. REG. 7-18-2000.  
 2,368,710. SIDE BY SIDE MANAGEMENT. INT. CL. 16. REG. 7-18-2000.  
 2,368,714. SPAR PRO. INT. CL. 28. REG. 7-18-2000.  
 2,368,716. TENDERSKIN. INT. CL. 24. REG. 7-18-2000.  
 2,368,720. SMALL BUSINESS TIMES AND DESIGN. INT. CL. 16. REG. 7-18-2000.  
 2,368,723. OVERWRAPPING SOLUTIONS. INT. CL. 16. REG. 7-18-2000.  
 2,368,724. SELFWELDING SHRINKITFILM. INT. CL. 16. REG. 7-18-2000.  
 2,368,725. ROBOCOM SYSTEMS INTERNATIONAL. INT. CL. 35. REG. 7-18-2000.  
 2,368,730. N10Z (INTENSE) (STYLIZED). INT. CL. 3. REG. 7-18-2000.  
 2,368,740. QUOTOGRAPHS AND DESIGN. INT. CL. 16. REG. 7-18-2000.  
 2,368,741. QUOTIVATIONALS AND DESIGN. INT. CL. 16. REG. 7-18-2000.  
 2,368,742. QUOTIVATIONS AND DESIGN. INT. CL. 16. REG. 7-18-2000.  
 2,368,752. SUPER CAGE UNITED STATES CRANE, INC. AND DESIGN. INT. CL. 42. REG. 7-18-2000.  
 2,368,755. BALANCE. INT. CL. 14. REG. 7-18-2000.  
 2,368,756. GROOME CAPITAL. INT. CL. 36. REG. 7-18-2000.  
 2,368,760. POST IMPRESSIONS. INT. CL. 41. REG. 7-18-2000.  
 2,368,779. BENCHMARK. INT. CL. 35. REG. 7-18-2000.  
 2,368,780. BEHOME. INT. CL. 35. REG. 7-18-2000.  
 2,368,788. PALISADE. INT. CL. 15. REG. 7-18-2000.  
 2,368,798. DOCUBROKER. INT. CL. 9. REG. 7-18-2000.  
 2,368,799. SECRET SERVICES AND DESIGN. INT. CL. 42. REG. 7-18-2000.  
 2,368,813. BUCK SNORT LODGE PRODUCTS. INT. CL. 6. REG. 7-18-2000.  
 2,368,817. WWW.OUTWATER.COM TOLL FREE 1-888-OUTWATER AND DESIGN. INT. CL. 6. REG. 7-18-2000.  
 2,368,824. COMMUNITY TOOLBOX BRINGING SOLUTIONS TO LIGHT AND DESIGN. INT. CL. 42. REG. 7-18-2000.  
 2,368,827. OUTREACH. INT. CL. 7. REG. 7-18-2000.  
 2,368,828. ANGLERS OUTPOST. INT. CL. 35. REG. 7-18-2000.  
 2,368,836. CLIENTCONNECT. INT. CL. 36. REG. 7-18-2000.  
 2,368,840. WADDLESNOUT. INT. CL. 35. REG. 7-18-2000.  
 2,368,856. SEA BYTE. INT. CL. 42. REG. 7-18-2000.  
 2,368,860. LOVE A CHILD AND DESIGN. INT. CL. 42. REG. 7-18-2000.  
 2,368,864. WEATHER STOPPER (STYLIZED). INT. CL. 19. REG. 7-18-2000.  
 2,368,866. FIREHAWK AND DESIGN. INT. CL. 12. REG. 7-18-2000.  
 2,368,868. IBI. INT. CL. 41. REG. 7-18-2000.  
 2,368,871. WINTITLE. INT. CL. 9. REG. 7-18-2000.  
 2,368,879. STURDI-GLIDE. INT. CL. 11. REG. 7-18-2000.  
 2,368,881. H AND DESIGN. INT. CL. 7. REG. 7-18-2000.

- 2,368,889. ISR THIS MOTOR WOUND WITH INVERTER SPIKE RESISTANT MAGNET WIRE BALDOR MOTORS AND DRIVES AND DESIGN. INT. CL. 7. REG. 7-18-2000.
- 2,368,900. ASI. INT. CLS. 6, 9, 19, 20 AND 21. REG. 7-18-2000.
- 2,368,903. SILENT PLAYER. INT. CLS. 25 AND 28. REG. 7-18-2000.
- 2,368,908. FOCUS ONE PROMOTIONS. INT. CL. 35. REG. 7-18-2000.
- 2,368,909. SPEED MITT. INT. CL. 21. REG. 7-18-2000.
- 2,368,913. THE NATIONAL FORUM OF THE \$20 BILLION GOVERNMENT TRAVEL MARKET. INT. CL. 42. REG. 7-18-2000.
- 2,368,916. INTELLIBLEND. INT. CL. 9. REG. 7-18-2000.
- 2,368,917. COMING TO. INT. CL. 41. REG. 7-18-2000.
- 2,368,923. ELEGANT EXTRAS. INT. CL. 14. REG. 7-18-2000.
- 2,368,924. YOGA PEOPLE. INT. CL. 41. REG. 7-18-2000.
- 2,368,926. APARTMENTWORLD.COM. INT. CL. 36. REG. 7-18-2000.
- 2,368,931. FURBY. INT. CL. 28. REG. 7-18-2000.
- 2,368,943. EYE VALU. INT. CL. 9. REG. 7-18-2000.
- 2,368,950. AUTOEDGE. U.S. CL. 200. REG. 7-18-2000.
- 2,368,952. LEGENDS FIELD SPRING HOME OF THE NEW YORK YANKEES NY AND DESIGN. INT. CLS. 16 AND 25. REG. 7-18-2000.
- 2,368,953. NCR AND DESIGN. INT. CLS. 9 AND 42. REG. 7-18-2000.
- 2,368,955. THE RIGHT START. INT. CL. 25. REG. 7-18-2000.
- 2,368,965. E Z ZIP RESEALABLE PACKAGING AND DESIGN. INT. CL. 16. REG. 7-18-2000.
- 2,368,970. VFAX. INT. CL. 9. REG. 7-18-2000.
- 2,368,971. PASTAROTTI ITALIAN PASTA & RISOTTI AND DESIGN. INT. CLS. 29 AND 30. REG. 7-18-2000.
- 2,368,989. QUAKEBRAKE. INT. CL. 6. REG. 7-18-2000.
- 2,369,007. GRANSASSO. INT. CLS. 19 AND 27. REG. 7-18-2000.
- 2,369,016. SEUSS WEAR. INT. CL. 25. REG. 7-18-2000.
- 2,369,023. MISCELLANEOUS DESIGN. INT. CL. 3. REG. 7-18-2000.
- 2,369,026. UNITED STATES SUBMARINE VETERANS AND DESIGN. U.S. CL. 200. REG. 7-18-2000.
- 2,369,030. SAFETY MATTERS. INT. CLS. 35 AND 42. REG. 7-18-2000.
- 2,369,036. ADELPHIA. INT. CL. 38. REG. 7-18-2000.
- 2,369,046. GO CAROLINAS.COM. INT. CL. 42. REG. 7-18-2000.
- 2,369,059. POWERED BY AMIGA AND DESIGN. INT. CL. 9. REG. 7-18-2000.
- 2,369,062. ARM. INT. CL. 7. REG. 7-18-2000.
- 2,369,065. ALTA. INT. CL. 14. REG. 7-18-2000.
- 2,369,071. FESTIVALE. INT. CL. 41. REG. 7-18-2000.
- 2,369,072. DILBERT. INT. CL. 21. REG. 7-18-2000.
- 2,369,073. THW DESIGN AND DESIGN. INT. CL. 42. REG. 7-18-2000.
- 2,369,080. BLACK LEGENDS PROFESSIONAL BASKETBALL AND DESIGN. INT. CLS. 25 AND 41. REG. 7-18-2000.
- 2,369,086. PLATINUM LINGERIE (STYLIZED). INT. CL. 25. REG. 7-18-2000.
- 2,369,093. EXTRA. INT. CLS. 6 AND 20. REG. 7-18-2000.
- 2,369,101. LIGHTLID. INT. CL. 9. REG. 7-18-2000.
- 2,369,113. TMX AND DESIGN. INT. CLS. 35 AND 40. REG. 7-18-2000.
- 2,369,123. TURBO TEC AND DESIGN. INT. CL. 28. REG. 7-18-2000.
- 2,369,126. ATAN AND DESIGN. INT. CL. 9. REG. 7-18-2000.
- 2,369,133. MAGNE-PRO. INT. CL. 11. REG. 7-18-2000.
- 2,369,151. DO-GREE. INT. CL. 25. REG. 7-18-2000.
- 2,369,158. SPEERINGS. INT. CL. 42. REG. 7-18-2000.
- 2,369,161. MISCELLANEOUS DESIGN. INT. CL. 11. REG. 7-18-2000.
- 2,369,187. NFL EUROPE LEAGUE AND DESIGN. INT. CL. 41. REG. 7-18-2000.
- 2,369,204. SEAL OF APPROVAL BT AND DESIGN. INT. CL. 25. REG. 7-18-2000.
- 2,369,216. TIMBERLINE PEAK PERFORMANCE AND DESIGN. INT. CL. 12. REG. 7-18-2000.
- 2,369,224. X. INT. CL. 6. REG. 7-18-2000.
- 2,369,232. VIA NEUTRALS. INT. CL. 16. REG. 7-18-2000.
- 2,369,233. SPS (STYLIZED). INT. CL. 6. REG. 7-18-2000.
- 2,369,235. LEADSEEKER. INT. CLS. 1, 9 AND 42. REG. 7-18-2000.
- 2,369,240. BIAST. INT. CL. 9. REG. 7-18-2000.
- 2,369,262. BUST A GROOVE. INT. CL. 9. REG. 7-18-2000.
- 2,369,264. FIAMME (STYLIZED). INT. CL. 3. REG. 7-18-2000.
- 2,369,268. PC AND DESIGN. INT. CL. 35. REG. 7-18-2000.
- 2,369,274. IT-S (STYLIZED). INT. CL. 12. REG. 7-18-2000.
- 2,369,277. TWISTED JOE'S. INT. CL. 35. REG. 7-18-2000.
- 2,369,278. VALUE FAMILIES. INT. CL. 42. REG. 7-18-2000.
- 2,369,283. FIRSTWAVE TECHNOLOGIES. INT. CL. 9. REG. 7-18-2000.
- 2,369,290. J3. INT. CL. 6. REG. 7-18-2000.
- 2,369,291. E-TRENDS. INT. CL. 9. REG. 7-18-2000.
- 2,369,309. ACCESSPAK. INT. CL. 5. REG. 7-18-2000.
- 2,369,314. FOREFIELD. INT. CL. 9. REG. 7-18-2000.
- 2,369,318. NIGHT HAWK. INT. CL. 9. REG. 7-18-2000.
- 2,369,323. CAD ZOOTS. INT. CL. 25. REG. 7-18-2000.
- 2,369,327. SMOOTH OPERATOR. INT. CL. 19. REG. 7-18-2000.
- 2,369,334. SPEEDSTOP. INT. CL. 35. REG. 7-18-2000.
- 2,369,336. RHOFFLEX. INT. CL. 19. REG. 7-18-2000.
- 2,369,338. THE HAWORTH HERBAL PRESS. INT. CL. 16. REG. 7-18-2000.
- 2,369,354. PLANET METAL. INT. CL. 16. REG. 7-18-2000.
- 2,369,359. D'STROYERS. INT. CL. 16. REG. 7-18-2000.
- 2,369,367. SUNBURST. INT. CL. 11. REG. 7-18-2000.
- 2,369,369. RONALD SHORE'S ICING ON THE CAKE. INT. CL. 9. REG. 7-18-2000.
- 2,369,387. NO TORQUE RIGHT. INT. CL. 10. REG. 7-18-2000.
- 2,369,408. SIGNATURE SELECTION. INT. CL. 9. REG. 7-18-2000.
- 2,369,426. PCT. INT. CL. 41. REG. 7-18-2000.
- 2,369,431. WILD ARUBA STUD. INT. CL. 41. REG. 7-18-2000.
- 2,369,432. BAFFLED. INT. CL. 41. REG. 7-18-2000.
- 2,369,442. PENN MATERNITY CARE. INT. CLS. 16, 41 AND 42. REG. 7-18-2000.
- 2,369,443. SQUEEZED OUT. INT. CL. 28. REG. 7-18-2000.
- 2,369,454. BUBBLEGUM. INT. CLS. 16 AND 28. REG. 7-18-2000.
- 2,369,459. ULTRA CHOICE. INT. CL. 5. REG. 7-18-2000.
- 2,369,475. THE PERENNIAL FARM. INT. CL. 39. REG. 7-18-2000.
- 2,369,479. JUNGLE ADVENTURES. INT. CL. 30. REG. 7-18-2000.
- 2,369,481. ONE-UPS. INT. CL. 3. REG. 7-18-2000.
- 2,369,487. FISHER'S ISLAND FERRIES. INT. CL. 25. REG. 7-18-2000.
- 2,369,494. CUTTYHUNK CRABCAKES. INT. CL. 25. REG. 7-18-2000.
- 2,369,497. NANTUCKET NIGHT CRAWLERS. INT. CL. 25. REG. 7-18-2000.
- 2,369,498. FIRE ISLAND FIREFLIES. INT. CL. 25. REG. 7-18-2000.
- 2,369,499. SUNTERRA AND DESIGN. INT. CLS. 35, 36, 39 AND 42. REG. 7-18-2000.
- 2,369,502. SHOWER SHINE. INT. CL. 3. REG. 7-18-2000.
- 2,369,537. FIRST AID PROFILE. INT. CL. 14. REG. 7-18-2000.
- 2,369,540. U.S. BRICK & BLOCK SYSTEMS, INC.. INT. CL. 37. REG. 7-18-2000.
- 2,369,544. THE TABLE YOU CAN TOTE. INT. CL. 16. REG. 7-18-2000.
- 2,369,545. COASTAL PAGES. INT. CL. 16. REG. 7-18-2000.
- 2,369,547. EZFIT. INT. CL. 14. REG. 7-18-2000.
- 2,369,551. PHOTO KEEPSAKE. INT. CL. 16. REG. 7-18-2000.
- 2,369,571. 2% 4% 6%. INT. CL. 36. REG. 7-18-2000.
- 2,369,574. OUTFITTERS ASSOCIATION OF AMERICA. INT. CL. 42. REG. 7-18-2000.
- 2,369,589. NATIONAL DIABETES ALLIANCE. INT. CL. 42. REG. 7-18-2000.
- 2,369,592. REPORT IT HOTLINE. INT. CL. 38. REG. 7-18-2000.
- 2,369,593. KALANI. INT. CL. 33. REG. 7-18-2000.
- 2,369,598. HEALTHCARE RISK MANAGEMENT. INT. CL. 16. REG. 7-18-2000.
- 2,369,607. CLICK & LISTEN. INT. CL. 38. REG. 7-18-2000.



- 2,369,608. WEALTH OPTIMIZATION MODEL. INT. CL. 41. REG. 7-18-2000.
- 2,370,118. LORENZO COLLEZIONE DONNA. INT. CL. 25. REG. 7-25-2000.
- 2,375,605. CHEF HARRY. INT. CL. 30. REG. 8-8-2000.
- 2,377,494. HYLIFE. INT. CL. 9. REG. 8-15-2000.
- 2,381,737. PIVOT ENABLED. INT. CL. 9. REG. 8-29-2000.
- 2,381,810. CARNIVAL AND DESIGN. INT. CL. 21 ONLY. REG. 8-29-2000.
- 2,381,990. ALLBOOKS4LESS.COM. INT. CL. 35. REG. 8-29-2000.
- 2,386,876. AIMSYSYSTEM. INT. CL. 9. REG. 9-19-2000.
- 2,387,748. AW ABBEY WALKER EXECUTIVE CARS & LIMOUSINES AND DESIGN. INT. CL. 39. REG. 9-19-2000.
- 2,390,593. FM CYBRARIAN. INT. CL. 42 ONLY. REG. 9-26-2000.
- 2,390,610. GASTROENTEROLOGY UPDATE. INT. CL. 16. REG. 9-26-2000.
- 2,390,649. UPDATE ON PERIODONTICS. INT. CL. 16. REG. 9-26-2000.
- 2,393,425. THE NET IMPERATIVE. INT. CL. 35. REG. 10-10-2000.
- 2,404,570. MARCUS. INT. CL. 25. REG. 11-14-2000.
- 2,407,463. PLAY.ANYTIME.ANYWHERE. INT. CLS. 9, 25, 28, 35, 36 AND 41. REG. 11-21-2000.
- 2,416,371. MAX GLO AND DESIGN. INT. CL. 28. REG. 12-26-2000.
- 2,416,667. SPORTSBETTING.COM. INT. CL. 41. REG. 12-26-2000.
- 2,416,678. SPORTSBETTING. INT. CL. 41. REG. 12-26-2000.
- 2,418,221. HIP HOP COMBINED WITH KOFI IS KOFRICA. INT. CL. 41. REG. 1-2-2001.
- 2,421,617. CYRTODIO. INT. CL. 9. REG. 1-16-2001.
- 2,421,992. MUD DOG AND DESIGN. INT. CL. 25. REG. 1-16-2001.
- 2,424,596. LW LITERACY WORKS AND DESIGN. INT. CL. 41. REG. 1-30-2001.
- 2,425,950. INTERCHANGE CAPITAL COMPANY. INT. CL. 36. REG. 1-30-2001.
- 2,428,573. KONAMI AND DESIGN. INT. CL. 16. REG. 2-13-2001.
- 2,429,998. TOGO'S GREAT SANDWICHES AND DESIGN. INT. CLS. 29 AND 30 ONLY. REG. 2-20-2001.
- 2,429,999. TOGO'S GREAT SANDWICHES AND DESIGN. INT. CLS. 29 AND 30 ONLY. REG. 2-20-2001.
- 2,432,884. THE DANCE OF LIFE. INT. CL. 16. REG. 3-6-2001.
- 2,440,815. BIORENEW. INT. CL. 5. REG. 4-3-2001.
- 2,447,278. HERMES AND DESIGN. INT. CLS. 8, 9, 20, 24, 28 AND 34 ONLY. REG. 5-1-2001.
- 2,448,918. VARIO (STYLIZED). INT. CLS. 7 AND 8. REG. 5-8-2001.
- 2,453,168. MUDCRAWLER. INT. CL. 42. REG. 5-22-2001.
- 2,455,383. PM FACTORS. INT. CL. 36. REG. 5-29-2001.
- 2,463,393. CZECHOSLOVAKIAN ORIGINAL LAGER BEER AND DESIGN. INT. CL. 32. REG. 6-26-2001.
- 2,468,037. SIMPLY SKIN. INT. CL. 42. REG. 7-10-2001.
- 2,469,345. LEADING LADIES. INT. CL. 41. REG. 7-17-2001.
- 2,470,281. VERSAPORT. INT. CL. 9. REG. 7-17-2001.
- 2,471,299. KENMORE CAMERA. INT. CL. 35. REG. 7-24-2001.
- 2,472,844. AL HIRT. INT. CL. 41. REG. 7-31-2001.
- 2,472,972. PYRIDIAM BLOCK & TILE AND DESIGN. INT. CL. 19. REG. 7-31-2001.
- 2,473,741. UP THE CREEK CAMP FIRED GRILL. INT. CL. 42. REG. 7-31-2001.
- 2,476,238. BILLY BLITZ. INT. CL. 25. REG. 8-7-2001.
- 2,481,263. THE MOD SQUAD. INT. CL. 41. REG. 8-28-2001.
- 2,487,681. MEDEA AND DESIGN. INT. CL. 9. REG. 9-11-2001.
- 2,488,300. REALINK. INT. CL. 9. REG. 9-11-2001.
- 2,489,666. RELIABLE AND DESIGN. INT. CL. 35. REG. 9-11-2001.
- 2,490,134. LOGOS COMMUNICATIONS, INCORPORATED. INT. CL. 35. REG. 9-18-2001.
- 2,490,469. ENGRAPH. INT. CL. 42. REG. 9-18-2001.
- 2,490,983. LOANTAMER. INT. CL. 36. REG. 9-18-2001.
- 2,491,403. HIGH ROAD. INT. CL. 11 ONLY. REG. 9-18-2001.
- 2,492,885. MAGNAWATCH. INT. CL. 14. REG. 9-25-2001.
- 2,496,797. BLADE-LOC. INT. CL. 8. REG. 10-9-2001.
- 2,498,926. VITA SOIL. INT. CLS. 1 AND 5. REG. 10-16-2001.
- 2,504,966. PANIC BUTTON. INT. CL. 30. REG. 11-6-2001.
- 2,510,300. ARNEX. INT. CL. 14. REG. 11-20-2001.
- 2,511,748. PVR WIZARD. INT. CL. 9. REG. 11-27-2001.
- 2,513,810. EXPRESSED WISHES. INT. CL. 36 ONLY. REG. 12-4-2001.
- 2,516,126. LUBE CITY. INT. CL. 37. REG. 12-11-2001.
- 2,517,945. CARE FOR WORK ENVIRONMENTS. INT. CL. 7. REG. 12-11-2001.
- 2,518,985. JOYCE MEDIA, INC.. INT. CLS. 9, 14, 26, 28 AND 41. REG. 12-18-2001.
- 2,524,332. CNW CUVÉE. INT. CL. 33. REG. 1-1-2002.
- 2,524,394. MULTITAK. INT. CL. 16. REG. 1-1-2002.
- 2,524,961. MUTTONHEAD AND DESIGN. INT. CL. 16. REG. 1-1-2002.
- 2,526,730. POWERTRACK (STYLIZED). INT. CL. 7. REG. 1-8-2002.
- 2,526,731. SUPERTRACK (STYLIZED). INT. CL. 7. REG. 1-8-2002.
- 2,527,598. R SYSTEMS. INT. CL. 42. REG. 1-8-2002.
- 2,528,495. AIM FOR MAINTENANCE MINDED DIETING MMD AND DESIGN. INT. CL. 42. REG. 1-8-2002.
- 2,528,577. XTERRA. INT. CL. 32. REG. 1-8-2002.
- 2,531,711. TIANDU AND DESIGN. INT. CL. 29. REG. 1-22-2002.
- 2,535,771. EBASE. INT. CL. 9. REG. 2-5-2002.
- 2,538,816. TOSCANO ANTICA RISERVA MONOPOLI DI STATO ITALIA AND DESIGN. INT. CL. 34. REG. 2-19-2002.
- 2,539,674. ONEIGHTYWORLD. INT. CLS. 9, 16, 25, 41 AND 42. REG. 2-19-2002.
- 2,539,675. 180WORLD AND DESIGN. INT. CLS. 9, 16, 25, 41 AND 42. REG. 2-19-2002.
- 2,539,741. AUTOMOBILE CLUB SOUTHERN CALIFORNIA AND DESIGN. INT. CL. 36. REG. 2-19-2002.
- 2,539,761. PVR. INT. CL. 9. REG. 2-19-2002.
- 2,540,504. MISCELLANEOUS DESIGN. INT. CL. 25. REG. 2-19-2002.
- 2,544,629. KITCHEN MAGICIAN. INT. CL. 42. REG. 3-5-2002.
- 2,547,201. 11Q AND DESIGN. INT. CL. 38. REG. 3-12-2002.
- 2,548,580. BIG TRUCK BUYS & EQUIPMENT. INT. CL. 16. REG. 3-12-2002.
- 2,550,979. TRUCKXCHANGE (STYLIZED). INT. CL. 35. REG. 3-19-2002.
- 2,551,903. WOOF-A-RONI LOVERS. INT. CL. 31. REG. 3-26-2002.
- 2,552,817. LIMSOURCE. INT. CL. 42. REG. 3-26-2002.
- 2,553,116. MIRACLE MILLENNIUM JUICER. INT. CL. 7. REG. 3-26-2002.
- 2,553,193. HEALTH SHOPPE AND DESIGN. INT. CL. 35 ONLY. REG. 3-26-2002.
- 2,553,841. COLOR ENDURANCE. INT. CL. 3. REG. 3-26-2002.
- 2,558,453. AMERICAN ASSOCIATION OF NUTRITIONAL MEDICINE AANM AND DESIGN. INT. CL. 42. REG. 4-9-2002.
- 2,559,945. MOVIEPRO. INT. CLS. 35 AND 41. REG. 4-9-2002.
- 2,561,113. PILKINGTON. INT. CL. 9. REG. 4-16-2002.
- 2,565,339. CHRISTIAN WARRIORS AND DESIGN. INT. CL. 16. REG. 4-30-2002.
- 2,569,665. AMERICAN SILK. INT. CL. 24. REG. 5-14-2002.
- 2,571,272. POLY-STRIP. INT. CL. 17. REG. 5-21-2002.
- 2,571,828. REDLINE STUDIOS A POST AND VISUAL EFFECTS COMPANY AND DESIGN. INT. CL. 41. REG. 5-21-2002.
- 2,572,918. PETRO-SORB. INT. CL. 3. REG. 5-28-2002.
- 2,573,415. POLY-JOINT. INT. CL. 17. REG. 5-28-2002.
- 2,575,681. CONTEMPOREL. INT. CL. 3. REG. 6-4-2002.
- 2,576,226. REZERVE ZIN (STYLIZED). INT. CL. 33. REG. 6-4-2002.
- 2,578,744. REAL MEN, REAL PUNCHES, REAL TOUGH. INT. CL. 41. REG. 6-11-2002.
- 2,581,020. VALEX. INT. CL. 39. REG. 6-18-2002.

- 2,588,355. EXPERIENCE THE ULTIMATE. INT. CL. 35. REG. 7-2-2002.
- 2,593,119. INLAND EMPIRE JOBS. INT. CL. 16. REG. 7-9-2002.
- 2,594,109. THE BRAVE CHICKEN. INT. CL. 25 ONLY. REG. 7-16-2002.
- 2,601,653. PROTRACKER. INT. CL. 9. REG. 7-30-2002.
- 2,605,406. THANKS FOR HAVING ME. INT. CL. 16. REG. 8-6-2002.
- 2,606,394. HEFEWEIZEN CLASSIC SUMMER BEER AND DESIGN. INT. CL. 42. REG. 8-13-2002.
- 2,611,479. BLEEDING EDGE MUSIC. INT. CL. 35. REG. 8-27-2002.
- 2,613,080. BABYCENTER AND DESIGN. INT. CLS. 16, 35 AND 42. REG. 8-27-2002.
- 2,613,333. VASOTRAX. INT. CL. 10. REG. 8-27-2002.
- 2,613,831. MISCELLANEOUS DESIGN. INT. CL. 5. REG. 9-3-2002.
- 2,621,093. GET YOUR GRIP ON HISTORY. INT. CL. 41. REG. 9-17-2002.
- 2,621,612. KEEPING SCORE. INT. CL. 25. REG. 9-17-2002.
- 2,623,760. BIZDEGREE. INT. CL. 35. REG. 9-24-2002.
- 2,626,982. SONIC EXCELLENCE. INT. CL. 41. REG. 9-24-2002.
- 2,629,372. LATINOISE.COM RUIDOLATINO.COM (STYLIZED). INT. CLS. 35 AND 41. REG. 10-1-2002.
- 2,633,053. REALPOINT. INT. CL. 36. REG. 10-8-2002.
- 2,633,626. METAL BUILDINGS INSTITUTE. INT. CL. 41. REG. 10-8-2002.
- 2,634,341. CHENEY VELVETS. INT. CL. 24. REG. 10-15-2002.
- 2,639,169. SSSS AND DESIGN. INT. CL. 9. REG. 10-22-2002.
- 2,648,149. NORSEMEN PRODUCTIONS, INC. AND DESIGN. INT. CL. 41. REG. 11-12-2002.
- 2,653,567. \*WEB AND DESIGN. INT. CLS. 9 AND 42. REG. 11-26-2002.
- 2,659,625. CENTRIX SOLUTIONS, INC. AND DESIGN. INT. CL. 42. REG. 12-10-2002.
- 2,663,358. ZX-1. INT. CL. 28. REG. 12-17-2002.
- 2,664,171. APRON STRINGS. INT. CL. 41. REG. 12-17-2002.
- 2,666,044. DISKOID. INT. CL. 9. REG. 12-24-2002.
- 2,673,256. BRONCHOSOFT. INT. CL. 9. REG. 1-7-2003.
- 2,676,433. THE PHOENIX SCHOOL. INT. CL. 41. REG. 1-21-2003.
- 2,684,230. C F O R W A R D INFORMATION TECHNOLOGIES AND DESIGN. INT. CL. 42. REG. 2-4-2003.
- 2,685,730. SENTRY. INT. CL. 12. REG. 2-11-2003.
- 2,685,946. TEAM FEVER. INT. CL. 25. REG. 2-11-2003.
- 2,686,549. JUDGMENT DAY. INT. CL. 9 ONLY. REG. 2-11-2003.
- 2,688,537. MAMAS OF INVENTION. INT. CL. 42. REG. 2-18-2003.
- 2,688,538. MAMAS OF INVENTION. INT. CL. 35. REG. 2-18-2003.
- 2,691,888. MRS. WINNER'S CHICKEN AND BISCUITS AND DESIGN. INT. CL. 42. REG. 3-4-2003.
- 2,696,996. GNOMON COPY INC. AND DESIGN. INT. CL. 35. REG. 3-18-2003.
- 2,702,246. HOMEOWNERSHIP IS STOCK IN AMERICA. INT. CL. 35. REG. 4-1-2003.
- 2,702,334. VISION CAPITAL & MANAGEMENT. INT. CL. 36. REG. 4-1-2003.
- 2,711,403. PROMOASSIST AND DESIGN. INT. CL. 42. REG. 4-29-2003.
- 2,713,605. PEX CONNECTION. INT. CL. 6 ONLY. REG. 5-6-2003.
- 2,713,642. BURNERMATE. INT. CL. 9. REG. 5-6-2003.
- 2,715,665. TARGET ROCK OYSTER. INT. CL. 31. REG. 5-13-2003.
- 2,717,645. RAVEN. INT. CL. 9. REG. 5-20-2003.
- 2,718,463. COMPAMERICA.COM. INT. CL. 35. REG. 5-27-2003.
- 2,719,729. OVER-SAND VEHICLE PERMIT CAPE POGUE WILDLIFE REFUGE AND WASQUE RESERVATION CHAPPAQUIDDICK ISLAND THE TRUSTEES OF RESERVATIONS THE TRUSTEES OF RESERVATIONS MASSACHUSETTS 1891 EXPIRES MARCH 31 AND DESIGN. INT. CL. 25. REG. 5-27-2003.
- 2,723,239. SYSTEM SILVALURE AND DESIGN. INT. CLS. 5, 9 AND 21. REG. 6-10-2003.
- 2,723,832. CHALLENGE & FUN. INT. CL. 35. REG. 6-10-2003.
- 2,725,766. GODDESSES. INT. CL. 16. REG. 6-10-2003.
- 2,726,765. TCS. INT. CL. 35. REG. 6-17-2003.
- 2,729,633. MASTERCARD M/CHIP. INT. CL. 9. REG. 6-24-2003.
- 2,731,720. BUG DOCTOR. INT. CL. 37. REG. 7-1-2003.
- 2,731,721. BIRD DOCTOR. INT. CL. 37. REG. 7-1-2003.
- 2,736,009. CORION. INT. CL. 9. REG. 7-15-2003.
- 2,736,990. TURBO WRENCH. INT. CL. 8. REG. 7-15-2003.
- 2,742,969. COOKED PERFECT. INT. CL. 29. REG. 7-29-2003.
- 2,744,275. MISCELLANEOUS DESIGN. INT. CL. 34. REG. 7-29-2003.
- 2,745,172. ALPHAGENOME. INT. CL. 36. REG. 7-29-2003.
- 2,747,488. SOCCERLANDIA. INT. CL. 9. REG. 8-5-2003.
- 2,750,371. TOBISHI. INT. CL. 10 ONLY. REG. 8-12-2003.
- 2,751,603. OUR PRODUCT IS STEEL. OUR STRENGTH IS PEOPLE.. INT. CLS. 1, 4, 6 AND 19. REG. 8-19-2003.
- 2,751,912. VICTORY. INT. CLS. 32 AND 43. REG. 8-19-2003.
- 2,754,777. WEBSITE2GO. INT. CLS. 38 AND 42. REG. 8-26-2003.
- 2,755,703. INVESTMENT PROFESSIONALS, INC. AND DESIGN. INT. CL. 36. REG. 8-26-2003.
- 2,766,025. ADOPTTECH. INT. CL. 42. REG. 9-23-2003.
- 2,766,672. SUNKIST SMILES. INT. CL. 31. REG. 9-23-2003.
- 2,766,731. STUYVESANT TOWN. INT. CL. 36. REG. 9-23-2003.
- 2,767,745. SNOW ANGEL. INT. CL. 28. REG. 9-23-2003.
- 2,775,330. CARIBBEAN TODAY AND DESIGN. INT. CL. 16. REG. 10-21-2003.
- 2,785,747. THE SWAMPERS. INT. CL. 9. REG. 11-25-2003.
- 2,792,572. PHIST. INT. CL. 41. REG. 12-9-2003.
- 2,792,858. TRANSSEAVISION. INT. CL. 9. REG. 12-9-2003.
- 2,809,721. CUT THE LEASH. INT. CL. 40. REG. 2-3-2004.
- 2,831,977. VISION PHOTOGRAPHY. INT. CL. 41. REG. 4-13-2004.
- 2,839,487. P-LASER. INT. CLS. 7, 9 AND 17. REG. 5-11-2004.
- 2,846,143. MISCELLANEOUS DESIGN. INT. CL. 36. REG. 5-25-2004.
- 2,861,465. PRESERVE IT!. INT. CL. 1. REG. 7-6-2004.
- 2,863,886. MANGO MANGO. INT. CL. 25. REG. 7-20-2004.
- 2,863,887. HERITAGE ARTISTS. INT. CL. 20. REG. 7-20-2004.
- 2,863,888. SNAPPY. INT. CL. 41. REG. 7-20-2004.
- 2,863,889. TRAFFIC EYE. INT. CL. 9. REG. 7-20-2004.
- 2,863,890. INFECTIOUS GROOVES. INT. CL. 9. REG. 7-20-2004.
- 2,863,891. ABACOR. INT. CL. 5. REG. 7-20-2004.
- 2,863,892. FIGHTO-NUTRIENTS. INT. CL. 5. REG. 7-20-2004.
- 2,863,898. HOMES FOR AMERICA A NONPROFIT HOUSING DEVELOPMENT CORP AND DESIGN. INT. CL. 37. REG. 7-20-2004.
- 2,863,900. LA GUADALUPANA AND DESIGN. INT. CL. 30. REG. 7-20-2004.
- 2,863,901. LA GUADALUPANA. INT. CLS. 30 AND 31. REG. 7-20-2004.
- 2,863,903. CSHELL (STYLIZED). INT. CL. 21. REG. 7-20-2004.
- 2,863,905. TLC TRI-LINE COVERAGE AND DESIGN. INT. CL. 36. REG. 7-20-2004.
- 2,863,907. EYE CANDY. INT. CL. 35. REG. 7-20-2004.
- 2,863,908. 24SEVEN. INT. CL. 16. REG. 7-20-2004.
- 2,863,914. REALUSER. INT. CLS. 9 AND 42. REG. 7-20-2004.
- 2,863,915. PINNACLE SYSTEMS GROUP INC. AND DESIGN. INT. CLS. 35 AND 42. REG. 7-20-2004.
- 2,863,916. VIDEO RATING AND DESIGN. INT. CL. 9. REG. 7-20-2004.
- 2,863,917. GAME ONE AND DESIGN. INT. CLS. 38 AND 42. REG. 7-20-2004.
- 2,863,919. MUJI. INT. CL. 35. REG. 7-20-2004.
- 2,863,923. PS3 (STYLIZED). INT. CL. 9. REG. 7-20-2004.
- 2,863,924. QUILLLOW. INT. CL. 24. REG. 7-20-2004.
- 2,863,926. TEEN REACH. INT. CLS. 41 AND 42. REG. 7-20-2004.

- 2,863,927. ECONOCSP. INT. CLS. 40 AND 42. REG. 7-20-2004.  
 2,863,929. ALLRYTE. INT. CLS. 5, 30 AND 42. REG. 7-20-2004.  
 2,863,930. OVEON. INT. CL. 12. REG. 7-20-2004.  
 2,863,931. ALYUM. INT. CL. 12. REG. 7-20-2004.  
 2,863,932. STEREK. INT. CL. 5. REG. 7-20-2004.  
 2,863,933. BEER.COM AND DESIGN. INT. CLS. 14 AND 25. REG. 7-20-2004.  
 2,863,934. IQBOT. INT. CL. 38. REG. 7-20-2004.  
 2,863,935. FLORIS VAN BOMMEL. INT. CLS. 14 AND 18. REG. 7-20-2004.  
 2,863,937. MIKE BURTON AND DESIGN. INT. CLS. 16, 35, 39, 41 AND 42. REG. 7-20-2004.  
 2,863,938. AKROS AND DESIGN. INT. CL. 36. REG. 7-20-2004.  
 2,863,940. @ AND DESIGN. INT. CLS. 9, 16, 35, 38 AND 41. REG. 7-20-2004.  
 2,863,942. INVOKE PROVOKE EVOKE. INT. CLS. 21 AND 25. REG. 7-20-2004.  
 2,863,943. OXXON PHARMACCINES. INT. CLS. 5, 9, 16 AND 42. REG. 7-20-2004.  
 2,863,944. SMART PARK. INT. CLS. 7, 9, 11, 37 AND 42. REG. 7-20-2004.  
 2,863,945. BUZ. INT. CL. 33. REG. 7-20-2004.  
 2,863,951. THE BENEVOLENT MUSHROOMS. INT. CL. 41. REG. 7-20-2004.  
 2,863,953. MICROLASER DISCECTOMY. INT. CL. 42. REG. 7-20-2004.  
 2,863,954. ENGENIUS. INT. CL. 9. REG. 7-20-2004.  
 2,863,955. LEARNNDIV. INT. CLS. 9, 16 AND 41. REG. 7-20-2004.  
 2,863,956. CHINASTAR COM WWW.CHINASTAR.COM AND DESIGN. INT. CLS. 9, 16, 38, 41 AND 42. REG. 7-20-2004.  
 2,863,959. CASHTECK. INT. CLS. 9, 16 AND 42. REG. 7-20-2004.  
 2,863,961. ALLIANCE. INT. CL. 33. REG. 7-20-2004.  
 2,863,964. SONOGRIP. INT. CL. 1. REG. 7-20-2004.  
 2,863,965. A J ANAND JON AND DESIGN. INT. CL. 25. REG. 7-20-2004.  
 2,863,967. REAL LIFE UV PROTECTION WITH ATTITUDE LYNN ROBERTS INTERNATIONAL AND DESIGN. INT. CL. 9. REG. 7-20-2004.  
 2,863,969. EASYJET EASYJET.COM AND DESIGN. INT. CLS. 3, 9, 14, 16, 18, 28, 29, 30, 32, 33, 34, 35, 38, 39, 41 AND 42. REG. 7-20-2004.  
 2,863,971. AMS-CC. INT. CL. 35. REG. 7-20-2004.  
 2,863,973. ADPROTECH. INT. CLS. 5, 10 AND 42. REG. 7-20-2004.  
 2,863,976. EFS. INT. CLS. 9, 35, 38 AND 42. REG. 7-20-2004.  
 2,863,977. COPERNIC.COM AND DESIGN. INT. CLS. 9 AND 42. REG. 7-20-2004.  
 2,863,979. ARABICA D'EXCEPTION GRAND ARABICA LEGAL LE GOUT AND DESIGN. INT. CL. 30. REG. 7-20-2004.  
 2,863,981. EKL. INT. CLS. 6, 9, 11, 40 AND 42. REG. 7-20-2004.  
 2,863,982. RY AND DESIGN. INT. CL. 43. REG. 7-20-2004.  
 2,863,984. CASHANOVA. INT. CL. 9. REG. 7-20-2004.  
 2,863,985. QUICKSHOP. INT. CL. 35. REG. 7-20-2004.  
 2,863,987. NISSEN AND DESIGN. INT. CLS. 8, 21 AND 24. REG. 7-20-2004.  
 2,863,989. HOT FLASH! A WOMAN'S CONNECTION. INT. CL. 16. REG. 7-20-2004.  
 2,863,990. MISCELLANEOUS DESIGN. INT. CLS. 9, 35 AND 42. REG. 7-20-2004.  
 2,863,991. HITASTEAS. INT. CLS. 1, 3 AND 30. REG. 7-20-2004.  
 2,863,992. CORPORATE MEMORY. INT. CL. 35. REG. 7-20-2004.  
 2,863,993. MEMORIA CORPORATIVA. INT. CL. 35. REG. 7-20-2004.  
 2,863,995. ASPIRAIR. INT. CLS. 10 AND 42. REG. 7-20-2004.  
 2,863,996. ONE STEP. INT. CLS. 9 AND 42. REG. 7-20-2004.  
 2,863,997. SQUARE 1 AND DESIGN. INT. CL. 35. REG. 7-20-2004.  
 2,863,999. ONZA. INT. CL. 9. REG. 7-20-2004.  
 2,864,000. VOCALIS. INT. CLS. 38 AND 42. REG. 7-20-2004.  
 2,864,001. 360 FLIP. INT. CL. 25. REG. 7-20-2004.  
 2,864,002. NOOKI AND DESIGN. INT. CL. 30. REG. 7-20-2004.  
 2,864,003. GARAGE DOCTORS AND DESIGN. INT. CLS. 2, 19, 37 AND 42. REG. 7-20-2004.  
 2,864,010. PRAIRIE MILL CAFE & BAKERY. INT. CL. 43. REG. 7-20-2004.  
 2,864,014. SHEERDECK. INT. CLS. 17 AND 19. REG. 7-20-2004.  
 2,864,016. MINAPOE AND DESIGN. INT. CLS. 3, 14, 18 AND 25. REG. 7-20-2004.  
 2,864,020. QIX. INT. CL. 7. REG. 7-20-2004.  
 2,864,021. MURFIE. INT. CL. 25. REG. 7-20-2004.  
 2,864,025. ONE WAY RECORDS. INT. CL. 9. REG. 7-20-2004.  
 2,864,030. VANTAGEMED. INT. CL. 9. REG. 7-20-2004.  
 2,864,032. MISCELLANEOUS DESIGN. INT. CLS. 29, 30, 31 AND 32. REG. 7-20-2004.  
 2,864,033. THE FOREVERLAST-GOLD COLLECTION. INT. CL. 14. REG. 7-20-2004.  
 2,864,035. PTM (STYLIZED). INT. CL. 20. REG. 7-20-2004.  
 2,864,036. SDS - SMART DATA SERVER. INT. CLS. 9, 16, 35, 38 AND 42. REG. 7-20-2004.  
 2,864,037. SOVSPERSE. INT. CL. 1. REG. 7-20-2004.  
 2,864,039. CHAINFORMATION STICK TO YOUR CONCEPT AND DESIGN. INT. CLS. 9, 35 AND 42. REG. 7-20-2004.  
 2,864,040. MOVA. INT. CL. 10. REG. 7-20-2004.  
 2,864,042. D.I.Y. DO IT YOURSELF AND DESIGN. INT. CL. 17. REG. 7-20-2004.  
 2,864,043. BUCK A DAY. INT. CL. 36. REG. 7-20-2004.  
 2,864,044. PRO EUROPE AND DESIGN. INT. CLS. 16, 35, 36, 37, 39, 40, 41 AND 42. REG. 7-20-2004.  
 2,864,049. FANDC. INT. CLS. 9, 16, 35, 36 AND 38. REG. 7-20-2004.  
 2,864,052. ROBOENHANCER. INT. CL. 9. REG. 7-20-2004.  
 2,864,055. P=U=R=E COMPOSITES AND DESIGN. INT. CLS. 1 AND 17. REG. 7-20-2004.  
 2,864,056. TIDY BUTT. INT. CLS. 10 AND 28. REG. 7-20-2004.  
 2,864,057. ALMIRALL AND DESIGN. INT. CL. 35. REG. 7-20-2004.  
 2,864,059. SPOT INC. AND DESIGN. INT. CL. 8. REG. 7-20-2004.  
 2,864,064. LIVEDEVICES AND DESIGN. INT. CLS. 9, 16, 38 AND 42. REG. 7-20-2004.  
 2,864,066. CHUBBLINK (STYLIZED). INT. CLS. 9, 16 AND 45. REG. 7-20-2004.  
 2,864,070. CO.RE1920. INT. CLS. 25 AND 35. REG. 7-20-2004.  
 2,864,074. ONE-OK OK AND DESIGN. INT. CL. 5. REG. 7-20-2004.  
 2,864,077. MISCELLANEOUS DESIGN. INT. CLS. 9 AND 25. REG. 7-20-2004.  
 2,864,079. AMOREPACIFIC HIGH LIFT (STYLIZED). INT. CL. 3. REG. 7-20-2004.  
 2,864,082. ALVIK (STYLIZED). INT. CLS. 16, 35, 38, 41 AND 42. REG. 7-20-2004.  
 2,864,083. BITHELABS. INT. CL. 5. REG. 7-20-2004.  
 2,864,084. GIGALITE AND DESIGN. INT. CL. 11. REG. 7-20-2004.  
 2,864,085. HOME HEALTHCARE LABORATORY OF AMERICA AND DESIGN. INT. CLS. 42 AND 44. REG. 7-20-2004.  
 2,864,086. BEARTIQUES. INT. CL. 28. REG. 7-20-2004.  
 2,864,089. AARO SYSTEMS. INT. CLS. 9, 35, 41 AND 42. REG. 7-20-2004.  
 2,864,090. SOPH. INT. CL. 3. REG. 7-20-2004.  
 2,864,095. SOFTLOOK. INT. CL. 20. REG. 7-20-2004.  
 2,864,100. SCHWARZKOPF PROFESSIONAL HAIRCARE FOR YOU. AND DESIGN. INT. CL. 3. REG. 7-20-2004.  
 2,864,101. FX9. INT. CL. 7. REG. 7-20-2004.  
 2,864,103. A (STYLIZED). INT. CL. 35. REG. 7-20-2004.  
 2,864,105. VOTETECH AND DESIGN. INT. CL. 9. REG. 7-20-2004.  
 2,864,107. LIFE SHOULD SOUND GOOD. INT. CL. 10. REG. 7-20-2004.  
 2,864,110. GEOX SPORT AND DESIGN. INT. CL. 25. REG. 7-20-2004.

- 2,864,111. RANCHO NATURA. INT. CLS. 29 AND 32. REG. 7-20-2004.
- 2,864,112. COOL SKIN. INT. CL. 3. REG. 7-20-2004.
- 2,864,114. HKS TECHNOLOGY AND DESIGN. INT. CLS. 7 AND 42. REG. 7-20-2004.
- 2,864,117. LAIKUS. INT. CLS. 18 AND 25. REG. 7-20-2004.
- 2,864,118. MISCELLANEOUS DESIGN. INT. CL. 41. REG. 7-20-2004.
- 2,864,123. SPIER (STYLIZED). INT. CL. 33. REG. 7-20-2004.
- 2,864,124. FILM WORKS COACHING. INT. CL. 41. REG. 7-20-2004.
- 2,864,125. MRS. BEASLEY. INT. CL. 28. REG. 7-20-2004.
- 2,864,126. PARADIGM. INT. CLS. 24, 25 AND 27. REG. 7-20-2004.
- 2,864,127. WHEELLOCK COLLEGE INSTITUTE FOR LEADERSHIP AND CAREER INITIATIVES. INT. CLS. 41 AND 42. REG. 7-20-2004.
- 2,864,128. THREE SQUARE GRILL. INT. CL. 43. REG. 7-20-2004.
- 2,864,129. TUFF MOVE. INT. CL. 25. REG. 7-20-2004.
- 2,864,131. ABUC. INT. CLS. 9 AND 16. REG. 7-20-2004.
- 2,864,132. POINT CLASSICS AND DESIGN. INT. CL. 9. REG. 7-20-2004.
- 2,864,134. THE HOLIDAY SAMPLER AND DESIGN. INT. CL. 9. REG. 7-20-2004.
- 2,864,136. HERSELF. INT. CL. 3. REG. 7-20-2004.
- 2,864,139. TOOLS4EVER AND DESIGN. INT. CL. 9. REG. 7-20-2004.
- 2,864,140. DYNASTREAM. INT. CLS. 3, 7 AND 40. REG. 7-20-2004.
- 2,864,141. METRO NETWORKS YOU CAN BUILD ON. INT. CL. 38. REG. 7-20-2004.
- 2,864,142. DGI INTEROPERABILITY COMPLIANCE PROCESS. INT. CL. 42. REG. 7-20-2004.
- 2,864,143. IM INTERMARKETING EXPRESS AND DESIGN. INT. CL. 35. REG. 7-20-2004.
- 2,864,148. VICTORIA & ALBERT. INT. CL. 11. REG. 7-20-2004.
- 2,864,149. CARPET CONDOM. INT. CL. 17. REG. 7-20-2004.
- 2,864,151. DOCTOR OF MOTORS AND DESIGN. INT. CL. 7. REG. 7-20-2004.
- 2,864,152. VISIONATIC. INT. CLS. 9, 37 AND 42. REG. 7-20-2004.
- 2,864,160. NANOPATE AND DESIGN. INT. CLS. 2, 6, 37 AND 40. REG. 7-20-2004.
- 2,864,161. MIRAMEL. INT. CL. 10. REG. 7-20-2004.
- 2,864,164. CTEX. INT. CLS. 9, 11 AND 12. REG. 7-20-2004.
- 2,864,168. HOW HAWAII CONNECTS. INT. CL. 38. REG. 7-20-2004.
- 2,864,169. PACIFIC LIGHT NET. INT. CL. 38. REG. 7-20-2004.
- 2,864,170. JANITORIAL 911. INT. CL. 3. REG. 7-20-2004.
- 2,864,173. SUPERMOTO USA. INT. CL. 41. REG. 7-20-2004.
- 2,864,176. NICHU HINOJOSA. INT. CL. 35. REG. 7-20-2004.
- 2,864,178. OLD TBILISI AND DESIGN. INT. CL. 33. REG. 7-20-2004.
- 2,864,180. MARY-KATE AND DASHLEY. INT. CLS. 3, 6, 9, 11, 14, 16, 18, 24, 25, 26, 28, 35 AND 41. REG. 7-20-2004.
- 2,864,182. PRISAVON. INT. CL. 1. REG. 7-20-2004.
- 2,864,185. ENERGY CAP. INT. CL. 9. REG. 7-20-2004.
- 2,864,187. TRIANGLE OF TRUTH. INT. CL. 35. REG. 7-20-2004.
- 2,864,188. ENDOANCHOR. INT. CL. 10. REG. 7-20-2004.
- 2,864,190. LOLLIPOPROCK! (STYLIZED). INT. CL. 9. REG. 7-20-2004.
- 2,864,196. FUSSY GIRL. INT. CL. 5. REG. 7-20-2004.
- 2,864,198. LONGWAVE. INT. CL. 9. REG. 7-20-2004.
- 2,864,199. HANDCRAFTED SOAPMAKERS GUILD. INT. CLS. 35 AND 41. REG. 7-20-2004.
- 2,864,202. MISCELLANEOUS DESIGN. INT. CL. 21. REG. 7-20-2004.
- 2,864,206. BLUE IS MY FAVORITE! M AND DESIGN. INT. CL. 25. REG. 7-20-2004.
- 2,864,208. PYRAMID SPACE AND DESIGN. INT. CL. 42. REG. 7-20-2004.
- 2,864,209. NUGENIX. INT. CL. 44. REG. 7-20-2004.
- 2,864,210. AGI SCHUTZ MERCHANDISING. INT. CLS. 40 AND 42. REG. 7-20-2004.
- 2,864,211. TCO 99 ECOLOGY ENERGY EMISSIONS ERGONOMICS AND DESIGN. U.S. CL. A. REG. 7-20-2004.
- 2,864,215. HOME LIBER. INT. CLS. 7, 9, 11 AND 38. REG. 7-20-2004.
- 2,864,216. NANO ELECTRONICS PLANET. INT. CLS. 35 AND 41. REG. 7-20-2004.
- 2,864,217. CLUB SANTOS LAGUNA AND DESIGN. INT. CL. 16. REG. 7-20-2004.
- 2,864,218. AVOIDING ARMAGEDDON. INT. CL. 41 ONLY. REG. 7-20-2004.
- 2,864,220. NANO ELECTRONICS PLANET.COM. INT. CL. 41. REG. 7-20-2004.
- 2,864,226. IBPA INTERNATIONAL BEVERAGE PACKAGING ASSOCIATION AND DESIGN. U.S. CL. 200. REG. 7-20-2004.
- 2,864,228. BL AND DESIGN. INT. CLS. 18, 25 AND 34. REG. 7-20-2004.
- 2,864,229. WEBDOCS. INT. CL. 36. REG. 7-20-2004.
- 2,864,233. SPLASHPAD. INT. CL. 37. REG. 7-20-2004.
- 2,864,234. 2 "BUBBLE" A FRIEND. INT. CL. 37. REG. 7-20-2004.
- 2,864,235. JUPITERDIRECT. INT. CL. 35. REG. 7-20-2004.
- 2,864,238. THE CHAMPION OF INDEPENDENT DISTRIBUTORS. INT. CL. 35. REG. 7-20-2004.
- 2,864,245. COOLED-SCOPE. INT. CL. 9. REG. 7-20-2004.
- 2,864,246. CERACASA CERAMICA CABRERA, S.A. AND DESIGN. INT. CL. 19. REG. 7-20-2004.
- 2,864,247. CLEOPATRA LEATHERLEAF. INT. CL. 31. REG. 7-20-2004.
- 2,864,248. ELECTROROOF AND DESIGN. INT. CL. 17. REG. 7-20-2004.
- 2,864,250. EUROX. INT. CL. 35. REG. 7-20-2004.
- 2,864,251. PRATO PRINCIPAL. INT. CL. 41. REG. 7-20-2004.
- 2,864,252. COLOR YOUR BUSINESS. INT. CL. 40. REG. 7-20-2004.
- 2,864,253. THE ORIGINAL TREE TRUNK (STYLIZED). INT. CL. 20. REG. 7-20-2004.
- 2,864,257. MISCELLANEOUS DESIGN. INT. CLS. 35, 36, 37, 38, 41, 42, 43, 44 AND 45. REG. 7-20-2004.
- 2,864,259. MISCELLANEOUS DESIGN. INT. CL. 9. REG. 7-20-2004.
- 2,864,261. POWERLINE. INT. CL. 35. REG. 7-20-2004.
- 2,864,262. RIGHTPATHING YOUR FUTURE PASSION GOALS VALUES PURPOSE BEHAVIOR SKILLS AND DESIGN. INT. CL. 35. REG. 7-20-2004.
- 2,864,264. SAFE T BACK INTEGRATED ANTI-SLIP UNDERLAY AND DESIGN. INT. CL. 27. REG. 7-20-2004.
- 2,864,265. DELTA MOON. INT. CL. 41. REG. 7-20-2004.
- 2,864,267. EM AND DESIGN. U.S. CL. 200. REG. 7-20-2004.
- 2,864,269. GTICES. INT. CL. 9. REG. 7-20-2004.
- 2,864,270. PTI POST-TENSIONING INSTITUTE MEMBER AND DESIGN. U.S. CL. 200. REG. 7-20-2004.
- 2,864,271. RIVER ROCK. INT. CL. 25. REG. 7-20-2004.
- 2,864,272. MISCELLANEOUS DESIGN. INT. CL. 25. REG. 7-20-2004.
- 2,864,273. TALON MID CAP FUND. INT. CL. 36. REG. 7-20-2004.
- 2,864,274. LION TARGET ENGINE (STYLIZED). INT. CLS. 9 AND 42. REG. 7-20-2004.
- 2,864,276. YOUR PARTNER IN HEALTH. INT. CL. 36. REG. 7-20-2004.
- 2,864,277. SMC (STYLIZED). INT. CL. 20. REG. 7-20-2004.
- 2,864,280. BEAUTY & FASHION AND DESIGN. INT. CL. 41. REG. 7-20-2004.
- 2,864,281. BUILDING POSITIVE ATTITUDES TO ACHIEVE HIGHER ALTITUDES IN LIFE. INT. CL. 41. REG. 7-20-2004.
- 2,864,283. QUICK CORNER. INT. CL. 9. REG. 7-20-2004.
- 2,864,294. VALSIR (STYLIZED). INT. CLS. 6, 11 AND 17. REG. 7-20-2004.
- 2,864,297. FIRSTTRACK. INT. CL. 42. REG. 7-20-2004.
- 2,864,301. GRANDSTAND. INT. CLS. 38 AND 41. REG. 7-20-2004.

- 2,864,303. GELMATIC. INT. CL. 11. REG. 7-20-2004.  
 2,864,304. LAUNDRYMONEY (STYLIZED). INT. CL. 36. REG. 7-20-2004.  
 2,864,305. SOFIA. INT. CL. 9. REG. 7-20-2004.  
 2,864,314. RIDGEFLOW. INT. CL. 11. REG. 7-20-2004.  
 2,864,323. BIG APPLE ANIME FEST. INT. CL. 41. REG. 7-20-2004.  
 2,864,325. OLD BEAR. INT. CLS. 30 AND 35. REG. 7-20-2004.  
 2,864,326. VSP VALUE SMART PRODUCTS AND DESIGN. INT. CLS. 3 AND 5. REG. 7-20-2004.  
 2,864,328. SHOWER OF LOVE AND DESIGN. INT. CL. 36. REG. 7-20-2004.  
 2,864,329. MISCELLANEOUS DESIGN. INT. CL. 31. REG. 7-20-2004.  
 2,864,331. KOLBE & KOLBE. INT. CLS. 19, 35 AND 37. REG. 7-20-2004.  
 2,864,333. CHICO. INT. CLS. 12, 28, 35 AND 37. REG. 7-20-2004.  
 2,864,336. RLISYS. INT. CL. 9. REG. 7-20-2004.  
 2,864,337. SPECWRITER. INT. CL. 9. REG. 7-20-2004.  
 2,864,344. PLANTELIER. INT. CL. 21. REG. 7-20-2004.  
 2,864,345. CAMPUS LODGE. INT. CL. 36. REG. 7-20-2004.  
 2,864,346. GREEN POWER SWITCH GENERATION PARTNERS. INT. CL. 35. REG. 7-20-2004.  
 2,864,347. ANTONIO MIRO. INT. CLS. 3, 14 AND 18. REG. 7-20-2004.  
 2,864,348. AMERICA AT HOME. INT. CL. 36. REG. 7-20-2004.  
 2,864,349. CARMINE'S RESTAURANT AND DESIGN. INT. CL. 43. REG. 7-20-2004.  
 2,864,351. LA MARCA. INT. CL. 25. REG. 7-20-2004.  
 2,864,353. FELONEX. INT. CL. 5. REG. 7-20-2004.  
 2,864,354. PALLADIO. INT. CL. 37. REG. 7-20-2004.  
 2,864,358. UDET ULTRA DEEP ENGINEERING + TECHNOLOGY AND DESIGN. INT. CL. 35. REG. 7-20-2004.  
 2,864,359. PH GREENZONE. INT. CL. 5. REG. 7-20-2004.  
 2,864,362. DORNOVEL. INT. CL. 5. REG. 7-20-2004.  
 2,864,363. DORIVIA. INT. CL. 5. REG. 7-20-2004.  
 2,864,365. PALLADIO HOMES. INT. CL. 37. REG. 7-20-2004.  
 2,864,366. IMAGINE IMAGING. INT. CL. 40. REG. 7-20-2004.  
 2,864,367. WEB CME UNIVERSITY AND DESIGN. INT. CL. 41. REG. 7-20-2004.  
 2,864,368. WEB CE UNIVERSITY AND DESIGN. INT. CL. 41. REG. 7-20-2004.  
 2,864,372. THE POWER BEHIND EBUSINESS. INT. CL. 42. REG. 7-20-2004.  
 2,864,373. UNI CASH AND DESIGN. INT. CL. 36. REG. 7-20-2004.  
 2,864,378. TURTLE HOMES. INT. CL. 42. REG. 7-20-2004.  
 2,864,379. MISCELLANEOUS DESIGN. INT. CL. 25. REG. 7-20-2004.  
 2,864,380. L&G MORTGAGEBANC. INT. CLS. 36 AND 41. REG. 7-20-2004.  
 2,864,381. TOGETHER FOR OUR MAJORITY. INT. CL. 35. REG. 7-20-2004.  
 2,864,382. IONOPLEX. INT. CLS. 17 AND 19. REG. 7-20-2004.  
 2,864,383. KEMIN AND DESIGN. INT. CLS. 30 AND 31. REG. 7-20-2004.  
 2,864,384. HOLOGRAPHIC. INT. CL. 3. REG. 7-20-2004.  
 2,864,387. MOLECULAR IMAGING OUTLOOK. INT. CLS. 16 AND 41. REG. 7-20-2004.  
 2,864,388. SOLUTIONS TO POLLUTION. INT. CLS. 35 AND 37. REG. 7-20-2004.  
 2,864,389. METRORETRO. INT. CL. 35. REG. 7-20-2004.  
 2,864,394. ANTISEPTIC BIO-HAND CLEANER. INT. CL. 5. REG. 7-20-2004.  
 2,864,395. THE OQUIRRH INSTITUTE AND DESIGN. INT. CLS. 41 AND 42. REG. 7-20-2004.  
 2,864,398. QUARTZ ELECTRONICS. INT. CL. 9. REG. 7-20-2004.  
 2,864,401. LIVE AND WEAR...SKIN TO SKIN.. INT. CL. 25. REG. 7-20-2004.  
 2,864,407. EVENTFX. INT. CL. 9. REG. 7-20-2004.  
 2,864,408. BERTOZZI PARMA PARMA STICKS AND DESIGN. INT. CL. 29. REG. 7-20-2004.  
 2,864,409. DUB - T AND DESIGN. INT. CL. 25. REG. 7-20-2004.  
 2,864,410. GREEN ROOFS FOR HEALTHY CITIES AND DESIGN. INT. CLS. 9, 16, 35, 41 AND 42. REG. 7-20-2004.  
 2,864,411. OMINOUS HORIZONS (STYLIZED). INT. CL. 9. REG. 7-20-2004.  
 2,864,412. CONNECTOR SPECIFIER. INT. CL. 16. REG. 7-20-2004.  
 2,864,413. STONECAM. INT. CLS. 7 AND 9. REG. 7-20-2004.  
 2,864,414. ACHIEVE! MINNEAPOLIS (STYLIZED). INT. CL. 41. REG. 7-20-2004.  
 2,864,418. CAROLIN. INT. CL. 19. REG. 7-20-2004.  
 2,864,420. SIA CARGO. INT. CL. 39. REG. 7-20-2004.  
 2,864,421. SURVEY SPREE. INT. CL. 35. REG. 7-20-2004.  
 2,864,422. MPI MULTICULTURAL INITIATIVE - IT'S ALL ABOUT BUSINESS AND DESIGN. INT. CL. 35. REG. 7-20-2004.  
 2,864,423. S SOCCER EXPRESS AND DESIGN. INT. CL. 35. REG. 7-20-2004.  
 2,864,424. MINIQ (STYLIZED). INT. CL. 9. REG. 7-20-2004.  
 2,864,425. THE CENTER FOR TRADITIONAL CHINESE MEDICINE INC. AND DESIGN. INT. CL. 5. REG. 7-20-2004.  
 2,864,426. SAN ANTONIO FARMS. INT. CL. 30. REG. 7-20-2004.  
 2,864,429. J.B. PRATA, LTD.. INT. CLS. 16 AND 17. REG. 7-20-2004.  
 2,864,431. H HACKER AND DESIGN. INT. CL. 20. REG. 7-20-2004.  
 2,864,432. JAG RN. INT. CL. 42. REG. 7-20-2004.  
 2,864,434. THE CHIPMUNKS. INT. CL. 41. REG. 7-20-2004.  
 2,864,441. SMA OUTFITTER. INT. CL. 42. REG. 7-20-2004.  
 2,864,442. LONGHORN DENTAL AND DESIGN. INT. CL. 44. REG. 7-20-2004.  
 2,864,447. THIS IS MURRAY'S CHEESE FARMSTEAD SELECTION ESTABLISHED 1940 AND DESIGN. INT. CLS. 29 AND 43. REG. 7-20-2004.  
 2,864,448. KOA KONNECT AND DESIGN. INT. CL. 38. REG. 7-20-2004.  
 2,864,449. MT MEMBERTRADE ADVISORY SERVICES, LLC AND DESIGN. INT. CL. 35. REG. 7-20-2004.  
 2,864,451. WINDSOR. INT. CLS. 16 AND 21. REG. 7-20-2004.  
 2,864,452. NUCH. INT. CL. 25. REG. 7-20-2004.  
 2,864,456. PRECURSOR INVESTMENT PERSPECTIVE. INT. CL. 16. REG. 7-20-2004.  
 2,864,457. GATEWAY TO GO. INT. CLS. 6 AND 19. REG. 7-20-2004.  
 2,864,458. LCL LEASEHOLD CONSULTANTS LLC AND ASSOCIATES AND DESIGN. INT. CL. 36. REG. 7-20-2004.  
 2,864,460. HECTRA HEALTH CARE AND TRAUMA AT REMOTE LOCATIONS AND DESIGN. INT. CL. 35. REG. 7-20-2004.  
 2,864,462. POST NEWS AND DESIGN. INT. CLS. 16 AND 35. REG. 7-20-2004.  
 2,864,464. MISCELLANEOUS DESIGN. INT. CL. 9. REG. 7-20-2004.  
 2,864,466. SEAWEED. INT. CLS. 9 AND 42. REG. 7-20-2004.  
 2,864,468. LONGHORN DENTAL. INT. CL. 44. REG. 7-20-2004.  
 2,864,472. CC COLLIN CHARLES CCUFFLETS (STYLIZED). INT. CL. 14. REG. 7-20-2004.  
 2,864,476. GRT. INT. CLS. 35 AND 42. REG. 7-20-2004.  
 2,864,479. TAMPA BAY INTERCONNECT. INT. CL. 35. REG. 7-20-2004.  
 2,864,480. WHEN IT COMES TO BANDING ... WEXLER HAS IT ALL WRAPPED UP!. INT. CL. 35. REG. 7-20-2004.  
 2,864,481. LIDIA'S. INT. CL. 21. REG. 7-20-2004.  
 2,864,485. TURF 'N AG AND DESIGN. INT. CL. 1. REG. 7-20-2004.  
 2,864,488. NEO DIO AND DESIGN. INT. CL. 9. REG. 7-20-2004.  
 2,864,489. PENINSULAR PREMIUM. INT. CL. 29. REG. 7-20-2004.  
 2,864,490. MISCELLANEOUS DESIGN. INT. CL. 30. REG. 7-20-2004.

- 2,864,492. PIPELINE REHABILITATION & MAINTENANCE AND DESIGN. INT. CL. 35. REG. 7-20-2004.
- 2,864,493. MICROFIELD. INT. CLS. 9 AND 10. REG. 7-20-2004.
- 2,864,494. CLICKIT. INT. CL. 35. REG. 7-20-2004.
- 2,864,495. THE BLOOD GROUP. INT. CL. 9. REG. 7-20-2004.
- 2,864,496. DTP DIETETIC TECHNICIANS IN PRACTICE A PRACTICE GROUP OF THE AMERICAN DIETETIC ASSOC. AND DESIGN. INT. CLS. 36 AND 41. REG. 7-20-2004.
- 2,864,499. CATS PAW. INT. CL. 10. REG. 7-20-2004.
- 2,864,500. BDSA. INT. CL. 42. REG. 7-20-2004.
- 2,864,503. PRAYER GARDEN. INT. CL. 9. REG. 7-20-2004.
- 2,864,504. SECOND CHILD. INT. CL. 41. REG. 7-20-2004.
- 2,864,505. STERLING DESIGN AND DESIGN. INT. CL. 37. REG. 7-20-2004.
- 2,864,508. ERIC THE ENTERPRISE RISK INTEGRATION CONSOLE AND DESIGN. INT. CL. 9. REG. 7-20-2004.
- 2,864,509. SWISHER SPRINGS. INT. CL. 40. REG. 7-20-2004.
- 2,864,510. IMAGIWARE. INT. CLS. 9 AND 42. REG. 7-20-2004.
- 2,864,512. MICHIGAN 99. INT. CL. 7. REG. 7-20-2004.
- 2,864,513. SFT COAT. INT. CL. 9. REG. 7-20-2004.
- 2,864,521. MISCELLANEOUS DESIGN. INT. CL. 9. REG. 7-20-2004.
- 2,864,523. LIFECHOICE MOBILITY (STYLIZED). INT. CL. 35. REG. 7-20-2004.
- 2,864,524. BONMARE BEACHWEAR AND DESIGN. INT. CLS. 16 AND 25. REG. 7-20-2004.
- 2,864,527. DURT A NATURAL LOOKING. ARTIFICIAL POTTING MATERIAL AND DESIGN. INT. CL. 26. REG. 7-20-2004.
- 2,864,528. TOTAL TEEN TV. INT. CL. 38. REG. 7-20-2004.
- 2,864,529. CLEVELAND FORCE (STYLIZED). INT. CL. 41. REG. 7-20-2004.
- 2,864,530. JAX SPLATS. INT. CL. 30. REG. 7-20-2004.
- 2,864,535. CODE MANAGEMENT. INT. CL. 35. REG. 7-20-2004.
- 2,864,537. AMERICYCLE. INT. CLS. 35 AND 37. REG. 7-20-2004.
- 2,864,539. MESSAGE IN A BOTTLE. INT. CL. 41. REG. 7-20-2004.
- 2,864,540. FLEET PAIN-RELIEF. INT. CL. 5. REG. 7-20-2004.
- 2,864,542. SPATIAL TECHNOLOGIES INDUSTRY ASSOCIATION. INT. CLS. 35 AND 41. REG. 7-20-2004.
- 2,864,544. THE PETTING ZOO AND DESIGN. INT. CL. 28. REG. 7-20-2004.
- 2,864,551. MODERN BODY. INT. CL. 41. REG. 7-20-2004.
- 2,864,553. MISCELLANEOUS DESIGN. INT. CL. 44. REG. 7-20-2004.
- 2,864,557. WSTY GROUP. INT. CL. 35. REG. 7-20-2004.
- 2,864,559. CURIIOUSCHAMELEON (STYLIZED). INT. CL. 25. REG. 7-20-2004.
- 2,864,560. MISCELLANEOUS DESIGN. INT. CL. 25. REG. 7-20-2004.
- 2,864,562. FLAVOR FEELINGS. INT. CL. 16. REG. 7-20-2004.
- 2,864,563. SOMEONE YOU KNOW NEEDS A HUG TODAY...IT MAY EVEN BE YOU!. INT. CL. 16. REG. 7-20-2004.
- 2,864,566. LADYEASE. INT. CL. 10. REG. 7-20-2004.
- 2,864,570. IFF XPRESS AND DESIGN. INT. CL. 35. REG. 7-20-2004.
- 2,864,572. PROLOZONE THERAPY. INT. CL. 44. REG. 7-20-2004.
- 2,864,573. SLEEP SMART GOLD. INT. CLS. 35 AND 44. REG. 7-20-2004.
- 2,864,575. DUPE IT. INT. CL. 43. REG. 7-20-2004.
- 2,864,579. SC/CHIPS. INT. CL. 35. REG. 7-20-2004.
- 2,864,580. NEW LINE MORTGAGE. INT. CL. 36. REG. 7-20-2004.
- 2,864,581. ESTEEM REALTY. INT. CL. 36. REG. 7-20-2004.
- 2,864,582. THE GOOD DOG FOUNDATION. INT. CL. 35. REG. 7-20-2004.
- 2,864,583. SPIDERS NO MORE AND DESIGN. INT. CL. 37. REG. 7-20-2004.
- 2,864,584. CHURCH OF THE CIRCLE AND DESIGN. INT. CL. 25. REG. 7-20-2004.
- 2,864,585. IBEX AND DESIGN. INT. CLS. 9 AND 42. REG. 7-20-2004.
- 2,864,586. AAA AMERICAN ALL ACCESSORIES AND DESIGN. INT. CL. 20. REG. 7-20-2004.
- 2,864,588. SOUNDS OF SISTERS. INT. CL. 16. REG. 7-20-2004.
- 2,864,589. HUGH JORGAN'S THE DUELING PIANO BAR. INT. CL. 41. REG. 7-20-2004.
- 2,864,590. MUSHROOMS LITES AND DESIGN. INT. CL. 25. REG. 7-20-2004.
- 2,864,597. VANITY FAIR IN CONCERT. INT. CL. 41. REG. 7-20-2004.
- 2,864,598. COOKER INSPIRED AMERICAN DINING AND DESIGN. INT. CL. 43. REG. 7-20-2004.
- 2,864,599. DBD. INT. CL. 25. REG. 7-20-2004.
- 2,864,600. DEFINITE BODIES (STYLIZED). INT. CL. 41. REG. 7-20-2004.
- 2,864,601. RED BARN GRILL. INT. CL. 43. REG. 7-20-2004.
- 2,864,603. INSIDE MOVES. INT. CL. 42. REG. 7-20-2004.
- 2,864,605. THE DAY (STYLIZED). INT. CL. 25. REG. 7-20-2004.
- 2,864,607. PIECING IT TOGETHER STANDARD CHARACTER MARK. INT. CL. 42. REG. 7-20-2004.
- 2,864,608. MISCELLANEOUS DESIGN. INT. CL. 25. REG. 7-20-2004.
- 2,864,609. CAPRIUM. INT. CL. 36. REG. 7-20-2004.
- 2,864,610. CLEARVIEW. INT. CL. 16. REG. 7-20-2004.
- 2,864,612. GET 3!. INT. CL. 41. REG. 7-20-2004.
- 2,864,615. WE'VE GOT YOU COVERED. INT. CL. 37. REG. 7-20-2004.
- 2,864,616. FACE OF AUSTRALIA. INT. CL. 3. REG. 7-20-2004.
- 2,864,617. SIMPLE, RELIABLE, LOW COST SINCE 1958.. INT. CL. 36. REG. 7-20-2004.
- 2,864,618. HS THAI INTERNATIONAL AND DESIGN. INT. CL. 30. REG. 7-20-2004.
- 2,864,619. NOT FAST FOOD...OVEN BAKED AND WORTH THE WAIT. INT. CL. 43. REG. 7-20-2004.
- 2,864,620. T2C3. INT. CL. 9. REG. 7-20-2004.
- 2,864,623. B BROWNREALTY ADVISORS AND DESIGN. INT. CL. 36. REG. 7-20-2004.
- 2,864,627. POWERNET. INT. CL. 9. REG. 7-20-2004.
- 2,864,628. ADVOCATES WITH PERSPECTIVE. INT. CL. 42. REG. 7-20-2004.
- 2,864,632. FITNESS CHOICE WELLNESS CENTER. INT. CL. 44. REG. 7-20-2004.
- 2,864,637. COLOR BOND. INT. CL. 2. REG. 7-20-2004.
- 2,864,639. SMART-PLUG. INT. CL. 1. REG. 7-20-2004.
- 2,864,642. SAND STACKERS AND DESIGN. INT. CL. 28. REG. 7-20-2004.
- 2,864,645. NCC (STYLIZED). INT. CL. 37. REG. 7-20-2004.
- 2,864,646. ENERGY WISE HEALTH HOME AND DESIGN. INT. CL. 37. REG. 7-20-2004.
- 2,864,647. TAQPLUS MAXX. INT. CL. 1. REG. 7-20-2004.
- 2,864,651. CURVES MATTER...PERFORMANCE TOO. INT. CL. 11. REG. 7-20-2004.
- 2,864,658. SAMSONIC. INT. CL. 9. REG. 7-20-2004.
- 2,864,661. VERSIGLIDE. INT. CL. 20. REG. 7-20-2004.
- 2,864,662. OPIA PROPERTIES (STYLIZED). INT. CL. 36. REG. 7-20-2004.
- 2,864,663. FITNESS CHOICE. INT. CL. 29. REG. 7-20-2004.
- 2,864,664. MIND/BODY EXPRESSIONS. INT. CL. 41. REG. 7-20-2004.
- 2,864,668. BODYBLENDS. INT. CL. 41. REG. 7-20-2004.
- 2,864,672. MISCELLANEOUS DESIGN. INT. CL. 35. REG. 7-20-2004.
- 2,864,674. RISE 'N SHINE. INT. CL. 3. REG. 7-20-2004.
- 2,864,675. WHERE BRIGHT IDEAS COME TO LIGHT (STYLIZED). INT. CL. 35. REG. 7-20-2004.
- 2,864,676. MISCELLANEOUS DESIGN. INT. CL. 35. REG. 7-20-2004.
- 2,864,677. NEED ICE?. INT. CL. 35. REG. 7-20-2004.
- 2,864,678. ROLLING THUNDER. INT. CL. 41. REG. 7-20-2004.
- 2,864,682. TECHNOLOGY IMPRESSIONS. INT. CL. 28. REG. 7-20-2004.

- 2,864,683. AUTHENTIC FUN. INT. CL. 28. REG. 7-20-2004.  
 2,864,684. RETRO-STOP. INT. CL. 6. REG. 7-20-2004.  
 2,864,688. GRANDWATER AND DESIGN. INT. CL. 37. REG. 7-20-2004.  
 2,864,690. FREE SYSTEM AND DESIGN. INT. CL. 20. REG. 7-20-2004.  
 2,864,698. YUM DROPS KISSING POTION. INT. CL. 28. REG. 7-20-2004.  
 2,864,702. KINU. INT. CL. 9. REG. 7-20-2004.  
 2,864,703. IRIS. INT. CL. 6. REG. 7-20-2004.  
 2,864,704. THE LEADERBOARD. INT. CL. 35. REG. 7-20-2004.  
 2,864,706. ATARAXIA. INT. CL. 40. REG. 7-20-2004.  
 2,864,707. ANALEX. INT. CL. 42. REG. 7-20-2004.  
 2,864,708. ANALEX AND DESIGN. INT. CL. 42. REG. 7-20-2004.  
 2,864,711. CORONA THE ORIGINAL PARTY BEER OF CINCO DE MAYO. INT. CL. 32. REG. 7-20-2004.  
 2,864,712. PIAFFE AND DESIGN. INT. CL. 5. REG. 7-20-2004.  
 2,864,720. AH BY AFTER HOURS (STYLIZED). INT. CLS. 14, 16 AND 25. REG. 7-20-2004.  
 2,864,721. TEAM LIZARD. INT. CL. 35. REG. 7-20-2004.  
 2,864,723. OPEN YOUR EARS. INT. CL. 35. REG. 7-20-2004.  
 2,864,724. BSI BACKFLOW SOLUTIONS, INC. AND DESIGN. INT. CL. 35. REG. 7-20-2004.  
 2,864,725. FIELD & STREAM. INT. CL. 33. REG. 7-20-2004.  
 2,864,726. MAGNETWARE. INT. CL. 9. REG. 7-20-2004.  
 2,864,727. ZENTARIS. INT. CLS. 1, 5, 10 AND 42. REG. 7-20-2004.  
 2,864,730. AN HONEST AUTO SHOP. INT. CL. 37. REG. 7-20-2004.  
 2,864,732. EFTYX. INT. CL. 5. REG. 7-20-2004.  
 2,864,733. XIMAGE. INT. CLS. 16 AND 40. REG. 7-20-2004.  
 2,864,734. IN PRINT-ONLINE-ANYTIME. INT. CL. 35. REG. 7-20-2004.  
 2,864,735. MLC. INT. CLS. 6, 9, 17, 40 AND 42. REG. 7-20-2004.  
 2,864,736. PAPERSPACE. INT. CL. 16. REG. 7-20-2004.  
 2,864,737. ANISANA. INT. CL. 5. REG. 7-20-2004.  
 2,864,739. EXTREME PERFORMANCE. INT. CL. 28. REG. 7-20-2004.  
 2,864,740. TRUSTED MEDIA NETWORKS, INC. AND DESIGN. INT. CL. 9. REG. 7-20-2004.  
 2,864,741. ENVIRO 300 AND DESIGN. INT. CL. 12. REG. 7-20-2004.  
 2,864,742. UF ULTIMATE FITNESS (STYLIZED). INT. CL. 41. REG. 7-20-2004.  
 2,864,743. ALDEAVISION. INT. CLS. 35 AND 38. REG. 7-20-2004.  
 2,864,744. JUST ONE MAP. INT. CL. 35. REG. 7-20-2004.  
 2,864,745. XC PERF-I SYSTEM. INT. CL. 35. REG. 7-20-2004.  
 2,864,746. ACCORSHOP. INT. CLS. 35 AND 38. REG. 7-20-2004.  
 2,864,747. DISEASE BENCHMARKS. INT. CL. 35. REG. 7-20-2004.  
 2,864,750. MISCELLANEOUS DESIGN. INT. CL. 16. REG. 7-20-2004.  
 2,864,751. INN FLIGHT HOTELS AND DESIGN. INT. CL. 43. REG. 7-20-2004.  
 2,864,753. IF (STYLIZED). INT. CL. 34. REG. 7-20-2004.  
 2,864,755. MONTEO. INT. CL. 10. REG. 7-20-2004.  
 2,864,756. MISCELLANEOUS DESIGN. INT. CLS. 25 AND 28. REG. 7-20-2004.  
 2,864,757. MAGIC BRIDGE. INT. CL. 16. REG. 7-20-2004.  
 2,864,758. MISCELLANEOUS DESIGN. INT. CL. 9. REG. 7-20-2004.  
 2,864,760. F N AND DESIGN. INT. CL. 25. REG. 7-20-2004.  
 2,864,761. WAVE PAVE. INT. CL. 19. REG. 7-20-2004.  
 2,864,766. PRINZING ENTERPRISES HELPING TO MAKE THE WORKPLACE SAFER (STYLIZED). INT. CLS. 16 AND 20. REG. 7-20-2004.  
 2,864,768. SERONO SYMPOSIA INTERNATIONAL AND DESIGN. INT. CLS. 16, 41 AND 44. REG. 7-20-2004.  
 2,864,769. ATLANTIS. INT. CL. 9. REG. 7-20-2004.  
 2,864,772. SLEDDING ON GRASS. INT. CL. 28. REG. 7-20-2004.  
 2,864,775. GLOBALEYE. INT. CL. 42. REG. 7-20-2004.  
 2,864,777. EXTREME AND DESIGN. INT. CL. 26. REG. 7-20-2004.  
 2,864,778. MG SPORT BY MERRYGARDEN AND DESIGN. INT. CL. 25. REG. 7-20-2004.  
 2,864,787. REN-X. INT. CL. 2. REG. 7-20-2004.  
 2,864,788. THE ORIGINAL CAST SOX. INT. CL. 10. REG. 7-20-2004.  
 2,864,789. B AND DESIGN. INT. CL. 25. REG. 7-20-2004.  
 2,864,790. SAND'OR, SOLID NATURE. INT. CLS. 1 AND 17. REG. 7-20-2004.  
 2,864,792. MR. MCGREGOR'S FENCE AND DESIGN. INT. CL. 9. REG. 7-20-2004.  
 2,864,793. DOCON. INT. CL. 9. REG. 7-20-2004.  
 2,864,795. SANIRINSE. INT. CLS. 1, 7 AND 41. REG. 7-20-2004.  
 2,864,796. OPIRUS. INT. CL. 12. REG. 7-20-2004.  
 2,864,798. ONE OF A KIND. INT. CLS. 16, 41 AND 45. REG. 7-20-2004.  
 2,864,799. CRANK YANKERS (STYLIZED). INT. CL. 41. REG. 7-20-2004.  
 2,864,801. AVINDY. INT. CL. 14. REG. 7-20-2004.  
 2,864,804. RICHFOOD AND DESIGN. INT. CLS. 29, 30 AND 32. REG. 7-20-2004.  
 2,864,805. NOVALGIN. INT. CL. 5. REG. 7-20-2004.  
 2,864,806. REPROZAN. INT. CL. 5. REG. 7-20-2004.  
 2,864,810. CMA CGM ABSOLUTE TRUST. INT. CL. 39. REG. 7-20-2004.  
 2,864,812. COFFEE CELEBRATION. INT. CL. 11. REG. 7-20-2004.  
 2,864,815. SOHO (STYLIZED). INT. CL. 20. REG. 7-20-2004.  
 2,864,816. UCI MEDICAL CENTER MOBILE MEDICINE SENIOR MOBILE HEALTH SERVICES AND DESIGN. INT. CL. 44. REG. 7-20-2004.  
 2,864,817. DENTBRYTE AND DESIGN. INT. CL. 35. REG. 7-20-2004.  
 2,864,818. SEA&STREAM AND DESIGN. INT. CL. 21. REG. 7-20-2004.  
 2,864,821. PENTA SPLITTER. INT. CLS. 9, 37 AND 42. REG. 7-20-2004.  
 2,864,822. SNOWPAC. INT. CL. 16. REG. 7-20-2004.  
 2,864,824. BALANCE A FITNESS STUDIO AND DESIGN. INT. CL. 41. REG. 7-20-2004.  
 2,864,825. CAMPANITA. INT. CL. 16. REG. 7-20-2004.  
 2,864,826. GIMME SUM. INT. CL. 25. REG. 7-20-2004.  
 2,864,829. MASALAA FINE INDIAN VEGETARIAN CUISINE AND DESIGN. INT. CL. 43. REG. 7-20-2004.  
 2,864,831. BUN & THIGH ROLLER. INT. CL. 28. REG. 7-20-2004.  
 2,864,833. RR. INT. CL. 16. REG. 7-20-2004.  
 2,864,834. SYN-FAB DC-1. INT. CL. 1. REG. 7-20-2004.  
 2,864,835. BORDER STICK-UPS. INT. CL. 16. REG. 7-20-2004.  
 2,864,836. TEXTILES 2 (STYLIZED). INT. CL. 35. REG. 7-20-2004.  
 2,864,840. MAP-MI AND DESIGN. INT. CL. 12. REG. 7-20-2004.  
 2,864,843. MICHAL NEGRIN AND DESIGN. INT. CLS. 18 AND 35. REG. 7-20-2004.  
 2,864,844. CARBOSPIN. INT. CLS. 1, 5, 9, 10, 41, 42 AND 44. REG. 7-20-2004.  
 2,864,846. ROUND TOWEL ROTATE YOUR BODY NOT YOUR TOWEL! AND DESIGN. INT. CL. 24. REG. 7-20-2004.  
 2,864,848. XENTIA. INT. CLS. 1, 3 AND 40. REG. 7-20-2004.  
 2,864,850. YACARANDA. INT. CLS. 3, 24 AND 25. REG. 7-20-2004.  
 2,864,851. GAME ADVANTAGE. INT. CL. 35. REG. 7-20-2004.  
 2,864,852. SEPPELT ST PETERS. INT. CL. 33. REG. 7-20-2004.  
 2,864,854. SANYLEG AND DESIGN. INT. CLS. 10 AND 25. REG. 7-20-2004.  
 2,864,857. THE LITERARY SPA. INT. CL. 41. REG. 7-20-2004.  
 2,864,859. COLLOSS. INT. CL. 5. REG. 7-20-2004.  
 2,864,860. VARITOP (STYLIZED). INT. CL. 7. REG. 7-20-2004.  
 2,864,862. EMPOVIA. INT. CL. 5. REG. 7-20-2004.

- 2,864,863. SEASTAR ALLIANCE AND DESIGN. INT. CLS. 1 AND 2. REG. 7-20-2004.
- 2,864,868. HOMESKILLS AND DESIGN. INT. CLS. 16 AND 41. REG. 7-20-2004.
- 2,864,870. LOUIS M. KFOURY FUNERAL SERVICE. INT. CL. 45. REG. 7-20-2004.
- 2,864,873. C SECURE AND DESIGN. INT. CL. 35. REG. 7-20-2004.
- 2,864,874. WASHINGTON ALLIANCE STANDARD CHARACTER MARK. INT. CL. 36. REG. 7-20-2004.
- 2,864,877. 10X AND DESIGN. INT. CL. 36. REG. 7-20-2004.
- 2,864,878. INDIANA INSURANCE MEMBER OF LIBERTY MUTUAL GROUP AND DESIGN. INT. CL. 36. REG. 7-20-2004.
- 2,864,879. STORM BUSTER AND DESIGN. INT. CL. 18. REG. 7-20-2004.
- 2,864,880. CHEF G'S SEAFOOD & STEAKHOUSE AND DESIGN. INT. CL. 43. REG. 7-20-2004.
- 2,864,881. SKWOOSH (STYLIZED). INT. CL. 28. REG. 7-20-2004.
- 2,864,882. SAMPLEEDGE. INT. CL. 35. REG. 7-20-2004.
- 2,864,883. PRIME LINK PLUS AND DESIGN. INT. CLS. 36 AND 40. REG. 7-20-2004.
- 2,864,890. PGI THE EVENT AND COMMUNICATIONS AGENCY. INT. CLS. 35, 39, 41 AND 42. REG. 7-20-2004.
- 2,864,892. ADI PET INC.. INT. CL. 35. REG. 7-20-2004.
- 2,864,893. ELIXIR PHARMACEUTICALS. INT. CL. 42. REG. 7-20-2004.
- 2,864,894. HARRIS BANK JOLIET N.A.. INT. CL. 36. REG. 7-20-2004.
- 2,864,897. LIQUORICE AND DESIGN. INT. CL. 33. REG. 7-20-2004.
- 2,864,898. MISCELLANEOUS DESIGN. INT. CL. 4. REG. 7-20-2004.
- 2,864,902. SAM SECURITY ACCESS MANAGER AND DESIGN. INT. CL. 9. REG. 7-20-2004.
- 2,864,903. BOMART AND DESIGN. INT. CL. 35. REG. 7-20-2004.
- 2,864,904. XENOC'S. INT. CL. 7. REG. 7-20-2004.
- 2,864,908. XTREME PHUNN (STYLIZED). INT. CL. 25. REG. 7-20-2004.
- 2,864,909. KANGOL AND DESIGN. INT. CL. 14. REG. 7-20-2004.
- 2,864,913. AUTOMOTIVE INGENUITY FROM FRANCE. INT. CL. 12. REG. 7-20-2004.
- 2,864,924. HIP SOLUTIONS. INT. CL. 21. REG. 7-20-2004.
- 2,864,925. AUCTIONHAWK. INT. CLS. 9, 35 AND 42. REG. 7-20-2004.
- 2,864,929. REMCO AND DESIGN. INT. CL. 28. REG. 7-20-2004.
- 2,864,932. LIVE LIFE ON THE RUN. INT. CL. 35. REG. 7-20-2004.
- 2,864,934. RAFFI AND DESIGN. INT. CLS. 3, 16, 33 AND 34. REG. 7-20-2004.
- 2,864,938. THE CHILDREN'S ART STUDIO AND DESIGN. INT. CL. 41. REG. 7-20-2004.
- 2,864,941. DRIVE-IN DEALS!. INT. CL. 43. REG. 7-20-2004.
- 2,864,945. EUROPE ASAP AND DESIGN. INT. CL. 39. REG. 7-20-2004.
- 2,864,950. THE TRANSPLANTS. INT. CL. 41. REG. 7-20-2004.
- 2,864,952. WHERE'S THAT RECIPE? AND DESIGN. INT. CL. 16. REG. 7-20-2004.
- 2,864,953. PERFECT DRIVE. INT. CL. 35. REG. 7-20-2004.
- 2,864,957. CHEF LAURENT. INT. CL. 29. REG. 7-20-2004.
- 2,864,958. SCENARIST STUDIO. INT. CL. 9. REG. 7-20-2004.
- 2,864,959. VYDRAIN. INT. CL. 10. REG. 7-20-2004.
- 2,864,962. D' BEST ONE 1 AND DESIGN. INT. CL. 34. REG. 7-20-2004.
- 2,864,963. BALINESE ROOM. INT. CLS. 25, 35 AND 41. REG. 7-20-2004.
- 2,864,964. LONGKEYBONE GOLD. INT. CL. 5. REG. 7-20-2004.
- 2,864,965. SECURIMETRICS. INT. CL. 9. REG. 7-20-2004.
- 2,864,967. NURELM. INT. CL. 9. REG. 7-20-2004.
- 2,864,968. EPISPEC. INT. CL. 5. REG. 7-20-2004.
- 2,864,971. MATRIX PACKAGING INC. AND DESIGN. INT. CLS. 20, 21 AND 40. REG. 7-20-2004.
- 2,864,973. PURSONIC MISTER. INT. CL. 11. REG. 7-20-2004.
- 2,864,974. COMBILOCK. INT. CL. 10. REG. 7-20-2004.
- 2,864,975. PLANTS WE ADORE A SUPERB NEW PICK EVERY MONTH AND DESIGN. INT. CL. 35. REG. 7-20-2004.
- 2,864,977. CULTURE. INT. CL. 3. REG. 7-20-2004.
- 2,864,981. SHE'S SO HOT AND DESIGN. INT. CL. 41. REG. 7-20-2004.
- 2,864,982. INTERNATIONAL GOOSE CALLING INVITATIONAL. INT. CL. 41. REG. 7-20-2004.
- 2,864,983. BEVERAGEONE. INT. CLS. 9 AND 42. REG. 7-20-2004.
- 2,864,986. THE GOOD SLICE (STYLIZED). INT. CL. 29. REG. 7-20-2004.
- 2,864,987. BABYINSIGHT AND DESIGN. INT. CLS. 40, 41 AND 44. REG. 7-20-2004.
- 2,864,988. BREEZE. INT. CLS. 9 AND 42. REG. 7-20-2004.
- 2,864,990. YAZZY BAG AND DESIGN. INT. CL. 18. REG. 7-20-2004.
- 2,864,991. PIBARA. INT. CL. 5. REG. 7-20-2004.
- 2,864,995. EAU PARESEUSE. INT. CL. 3. REG. 7-20-2004.
- 2,864,996. CENTER FOR SPIRITUALITY AND HEALING ACADEMICHEALTHCENTER UNIVERSITY OF MINNESOTA AND DESIGN. INT. CL. 42. REG. 7-20-2004.
- 2,864,997. G-SQUARED. INT. CL. 44. REG. 7-20-2004.
- 2,865,006. ALBIS. INT. CL. 33. REG. 7-20-2004.
- 2,865,007. GILBERT STORSCAN. INT. CLS. 38 AND 39. REG. 7-20-2004.
- 2,865,008. COSMENCE EX-TENSE. INT. CL. 3. REG. 7-20-2004.
- 2,865,010. MISCELLANEOUS DESIGN. INT. CL. 38. REG. 7-20-2004.
- 2,865,011. ACTIVE CLIENT. INT. CL. 9. REG. 7-20-2004.
- 2,865,013. VOLUM MAKER. INT. CL. 3. REG. 7-20-2004.
- 2,865,014. W WEBSTER WE FIND A WAY AND DESIGN. INT. CL. 36. REG. 7-20-2004.
- 2,865,015. TODD WELSH. INT. CL. 25. REG. 7-20-2004.
- 2,865,017. METRIKA AND DESIGN. INT. CL. 10. REG. 7-20-2004.
- 2,865,019. CYDNI PROFESSIONAL HAIRCARE. INT. CL. 3. REG. 7-20-2004.
- 2,865,022. SALESOUTLOOK. INT. CL. 9. REG. 7-20-2004.
- 2,865,023. GUARANACO. INT. CL. 30. REG. 7-20-2004.
- 2,865,026. MEMBER COMMUNITY BANGROUP AND DESIGN. INT. CL. 36. REG. 7-20-2004.
- 2,865,027. HAURI AND DESIGN. INT. CL. 42. REG. 7-20-2004.
- 2,865,028. NIGHTFALL. INT. CL. 20. REG. 7-20-2004.
- 2,865,029. ROVIDECOR. INT. CL. 24. REG. 7-20-2004.
- 2,865,030. Q PRESENTER AND DESIGN. INT. CL. 9. REG. 7-20-2004.
- 2,865,032. DB DOMBA AND DESIGN. INT. CL. 25. REG. 7-20-2004.
- 2,865,042. PREMIUM LITE AND DESIGN. INT. CL. 29. REG. 7-20-2004.
- 2,865,043. TOMPAC. INT. CL. 18. REG. 7-20-2004.
- 2,865,045. DEEPNINE. INT. CL. 9. REG. 7-20-2004.
- 2,865,052. FRONTLINE LENDING CORPORATION HOME MORTGAGES ACROSS THE COUNTRY... AND IN YOUR NEIGHBORHOOD! AND DESIGN. INT. CL. 36. REG. 7-20-2004.
- 2,865,053. DEN MAR AND DESIGN. INT. CL. 9. REG. 7-20-2004.
- 2,865,054. CASABLANCA SMART EDIT. INT. CL. 9. REG. 7-20-2004.
- 2,865,057. DEFINITIVE MEASURES. INT. CL. 41. REG. 7-20-2004.
- 2,865,059. DRAMATEYES AND DESIGN. INT. CL. 3. REG. 7-20-2004.
- 2,865,061. ALTIMA. INT. CL. 24. REG. 7-20-2004.
- 2,865,062. TRIPLE CHESS. INT. CL. 28. REG. 7-20-2004.
- 2,865,063. DESCORAPID. INT. CL. 5. REG. 7-20-2004.
- 2,865,064. DESCOGEN. INT. CL. 5. REG. 7-20-2004.
- 2,865,065. SUPERFICID. INT. CL. 5. REG. 7-20-2004.
- 2,865,066. NEWTECH AND DESIGN. INT. CL. 10. REG. 7-20-2004.



- 2,865,067. VISSAN AND DESIGN. INT. CL. 29. REG. 7-20-2004.
- 2,865,068. DELIGHTER. INT. CL. 21. REG. 7-20-2004.
- 2,865,071. EAGLE AND DESIGN. INT. CL. 16. REG. 7-20-2004.
- 2,865,075. SF INFANT-FROSTING. INT. CL. 5. REG. 7-20-2004.
- 2,865,078. EHOBBIES. INT. CL. 35. REG. 7-20-2004.
- 2,865,080. RAC + MEDICAL AND DESIGN. INT. CL. 5. REG. 7-20-2004.
- 2,865,088. INSULGLASS. INT. CL. 17. REG. 7-20-2004.
- 2,865,090. MARINACTION. INT. CL. 3. REG. 7-20-2004.
- 2,865,091. POWER TECH AND DESIGN. INT. CL. 28. REG. 7-20-2004.
- 2,865,092. PREPAID WIRELESS WHERE YOU CONTROL YOUR COSTS. INT. CLS. 9, 35 AND 38. REG. 7-20-2004.
- 2,865,094. TRADEMARK UNIVERSE. INT. CL. 42. REG. 7-20-2004.
- 2,865,095. NEOELAST. INT. CL. 20. REG. 7-20-2004.
- 2,865,096. AQUA EDGE. INT. CL. 32. REG. 7-20-2004.
- 2,865,098. DISCOVER THE POWER OF NEEM AND DESIGN. INT. CL. 3. REG. 7-20-2004.
- 2,865,099. VIDEO VR ROOM AND DESIGN. INT. CLS. 35 AND 41. REG. 7-20-2004.
- 2,865,103. THE KNIFE AUTHORITY. INT. CL. 35. REG. 7-20-2004.
- 2,865,104. PERMISSION TO SUCCEED. INT. CL. 9. REG. 7-20-2004.
- 2,865,105. ROYALTY. INT. CL. 29. REG. 7-20-2004.
- 2,865,106. K KLIM AGGRESSIVE SLED WEAR AND DESIGN. INT. CL. 25. REG. 7-20-2004.
- 2,865,107. UNI AND DESIGN. INT. CL. 36. REG. 7-20-2004.
- 2,865,108. BLUEKEY. INT. CL. 9. REG. 7-20-2004.
- 2,865,109. WEEKEND WARRIOR EXPO. INT. CL. 35. REG. 7-20-2004.
- 2,865,113. MY PET'S ANIMAL HOSPITAL AND DESIGN. INT. CL. 44. REG. 7-20-2004.
- 2,865,117. IHC AND DESIGN. INT. CL. 41. REG. 7-20-2004.
- 2,865,119. IBT AND DESIGN. INT. CL. 36. REG. 7-20-2004.
- 2,865,124. WE MAKE APPLE INTERESTING. INT. CL. 32. REG. 7-20-2004.
- 2,865,130. SCREAM BODY JEWELRY. INT. CL. 35. REG. 7-20-2004.
- 2,865,131. FA SYSTEM. INT. CL. 28. REG. 7-20-2004.
- 2,865,132. TALKING BABY! AND DESIGN. INT. CL. 41. REG. 7-20-2004.
- 2,865,133. MASTER MASSAGE TABLES CHICAGO AND DESIGN. INT. CL. 10. REG. 7-20-2004.
- 2,865,134. WRAP 'N' SNAP (STYLIZED). INT. CL. 16. REG. 7-20-2004.
- 2,865,135. BRAZIE'S. INT. CL. 43. REG. 7-20-2004.
- 2,865,137. GENTLEMEN START YOUR ENGINES. INT. CL. 5. REG. 7-20-2004.
- 2,865,138. ADA RACING AND DESIGN. INT. CL. 12. REG. 7-20-2004.
- 2,865,141. AWAKENING HEARTLIGHT. INT. CL. 16. REG. 7-20-2004.
- 2,865,142. LIVING JOYFULLY. INT. CL. 16. REG. 7-20-2004.
- 2,865,143. MW MANAGER WAREHOUSE (STYLIZED). INT. CL. 9. REG. 7-20-2004.
- 2,865,144. FOR WHAT YOU'RE NOT EXPECTING.. INT. CL. 44. REG. 7-20-2004.
- 2,865,145. TUTORPAD. INT. CL. 9. REG. 7-20-2004.
- 2,865,148. THE PROFESSIONAL DIABETIC. INT. CLS. 16, 25 AND 28. REG. 7-20-2004.
- 2,865,151. CAREERPHILLY. INT. CL. 35. REG. 7-20-2004.
- 2,865,155. BODY BY DESIGN. INT. CL. 3. REG. 7-20-2004.
- 2,865,156. EXTREME SPECIES (STYLIZED). INT. CL. 25. REG. 7-20-2004.
- 2,865,160. TES, TRIPI ENGINEERING SERVICES, LLC AND DESIGN. INT. CL. 42. REG. 7-20-2004.
- 2,865,161. MYCXTEC. INT. CL. 42. REG. 7-20-2004.
- 2,865,164. GROOVE ROOMS. INT. CL. 43. REG. 7-20-2004.
- 2,865,168. DIGNITY HEALTH AND HOME CARE. INT. CL. 44. REG. 7-20-2004.
- 2,865,169. WARCRAFT. INT. CL. 28. REG. 7-20-2004.
- 2,865,171. AMERICAN SPORT SHOOTING ASSOCIATION. INT. CLS. 35 AND 41. REG. 7-20-2004.
- 2,865,172. DIGNITY BY DESIGN. INT. CL. 25. REG. 7-20-2004.
- 2,865,173. LANSOMNIA. INT. CL. 41. REG. 7-20-2004.
- 2,865,178. ENSTAR AND DESIGN. INT. CL. 17. REG. 7-20-2004.
- 2,865,179. THE US BUZZ-COUPLE. INT. CL. 16. REG. 7-20-2004.
- 2,865,180. TEA TRAVEL EXHIBITION OF THE AMERICAS AND DESIGN. INT. CL. 35. REG. 7-20-2004.
- 2,865,181. MAINSTREET MESSENGER. INT. CL. 9. REG. 7-20-2004.
- 2,865,182. RILNIGA. INT. CL. 25. REG. 7-20-2004.
- 2,865,188. FERTI-CAST. INT. CL. 1. REG. 7-20-2004.
- 2,865,195. SEA WASH. INT. CL. 25. REG. 7-20-2004.
- 2,865,203. PEAKVIEW. INT. CL. 9. REG. 7-20-2004.
- 2,865,206. RIVER VALLEY FLOWERS. INT. CL. 31. REG. 7-20-2004.
- 2,865,207. SOL SOCKS. INT. CL. 25. REG. 7-20-2004.
- 2,865,208. FINANCIALBLVD.COM. INT. CL. 35. REG. 7-20-2004.
- 2,865,209. TRITON. INT. CL. 15. REG. 7-20-2004.
- 2,865,211. DB DENIM DANA BUCHMAN (STYLIZED). INT. CL. 25. REG. 7-20-2004.
- 2,865,212. KIOMETER. INT. CL. 35. REG. 7-20-2004.
- 2,865,214. VERTIMEND. INT. CL. 1. REG. 7-20-2004.
- 2,865,215. HOMES AND AGENTS, INC.. INT. CL. 42. REG. 7-20-2004.
- 2,865,216. MYREPLAYTV. INT. CL. 41. REG. 7-20-2004.
- 2,865,219. STONEAGE. INT. CL. 3. REG. 7-20-2004.
- 2,865,220. BLACKOUT. INT. CL. 3. REG. 7-20-2004.
- 2,865,221. BLUE ROCK. INT. CL. 25. REG. 7-20-2004.
- 2,865,228. DONEWITHONE. INT. CL. 16. REG. 7-20-2004.
- 2,865,232. ALMARRO. INT. CL. 9. REG. 7-20-2004.
- 2,865,233. CYOC. INT. CL. 41. REG. 7-20-2004.
- 2,865,237. WE WORK HARD TO SAY YES. INT. CL. 36. REG. 7-20-2004.
- 2,865,238. FIREMAX. INT. CL. 9. REG. 7-20-2004.
- 2,865,239. RYCAN. INT. CL. 42. REG. 7-20-2004.
- 2,865,240. NATURALIZER IMPRESSION. INT. CL. 20. REG. 7-20-2004.
- 2,865,242. BAKER'S ELITE. INT. CL. 30. REG. 7-20-2004.
- 2,865,243. WAN-BERNADEL. INT. CL. 15. REG. 7-20-2004.
- 2,865,244. IDETIX. INT. CL. 9. REG. 7-20-2004.
- 2,865,247. CLOSETS AND MORE CLOSETS. INT. CL. 37. REG. 7-20-2004.
- 2,865,248. SOILSAFE. INT. CL. 40. REG. 7-20-2004.
- 2,865,250. PESTPATROL. INT. CL. 9. REG. 7-20-2004.
- 2,865,252. SNAPPLE PIE. INT. CL. 32. REG. 7-20-2004.
- 2,865,253. THE ULTIMATE SUMMER YOUTH CAMP. INT. CL. 41. REG. 7-20-2004.
- 2,865,258. AGENT AND DESIGN. INT. CL. 25. REG. 7-20-2004.
- 2,865,261. BLACK TIE PUBLICATIONS. INT. CL. 35. REG. 7-20-2004.
- 2,865,262. TRUCKSHARE. INT. CL. 39. REG. 7-20-2004.
- 2,865,263. NETFINDER. INT. CL. 28. REG. 7-20-2004.
- 2,865,264. HOTSHOT. INT. CL. 28. REG. 7-20-2004.
- 2,865,265. KALEXSYN. INT. CL. 42. REG. 7-20-2004.
- 2,865,268. KITTY KITTY BANG BANG. INT. CL. 41. REG. 7-20-2004.
- 2,865,270. HANDWRITER. INT. CL. 9. REG. 7-20-2004.
- 2,865,271. FRONTIER. INT. CL. 28. REG. 7-20-2004.
- 2,865,273. STORELAW. INT. CL. 9. REG. 7-20-2004.
- 2,865,276. SCAM-CO.'S SNEEZING POWDER. GIVE A WHOLE ROOMFUL OF PEOPLE THE SNEEZES! 162-LARGE SUPPLY- \$1.25 AND DESIGN. INT. CL. 25. REG. 7-20-2004.
- 2,865,279. MOONSTRUCK JEWELS AND DESIGN. INT. CLS. 14 AND 35. REG. 7-20-2004.
- 2,865,280. MAYYA GROUP INTERNATIONAL, LLC "ALL ABOUT WATER AND THE ENVIRONMENT" AND DESIGN. INT. CL. 42. REG. 7-20-2004.
- 2,865,284. THE BIG DIPPER. INT. CL. 35. REG. 7-20-2004.
- 2,865,285. BUILT UPON A FIRM FOUNDATION. INT. CLS. 37 AND 42. REG. 7-20-2004.
- 2,865,286. COURSESTUDIO. INT. CL. 9. REG. 7-20-2004.

- 2,865,287. FLIP DOG. INT. CL. 41. REG. 7-20-2004.  
 2,865,289. LIBERTY BELLES. INT. CL. 41. REG. 7-20-2004.  
 2,865,295. LENDERLAB.COM AND DESIGN. INT. CL. 36. REG. 7-20-2004.  
 2,865,302. PRESERVING THE NATIVE SPIRIT OF THE DESERT. INT. CL. 41. REG. 7-20-2004.  
 2,865,303. ALPHAECLIPSE. INT. CL. 9. REG. 7-20-2004.  
 2,865,304. AS LEGAL AND DESIGN. INT. CL. 9. REG. 7-20-2004.  
 2,865,307. DANDY-LION. INT. CL. 30. REG. 7-20-2004.  
 2,865,309. A AND DESIGN. INT. CLS. 3 AND 5. REG. 7-20-2004.  
 2,865,310. STK/OD. INT. CL. 9. REG. 7-20-2004.  
 2,865,311. AGOGO STAR. INT. CL. 35. REG. 7-20-2004.  
 2,865,314. WAVE MAVERICK. INT. CL. 25. REG. 7-20-2004.  
 2,865,315. THE OTHER PAGES AND DESIGN. INT. CL. 16. REG. 7-20-2004.  
 2,865,316. THE FREEDOM PAGES AND DESIGN. INT. CL. 16. REG. 7-20-2004.  
 2,865,317. ECOACTIVA. INT. CL. 1. REG. 7-20-2004.  
 2,865,322. CHER XTREME. INT. CL. 41. REG. 7-20-2004.  
 2,865,323. SMOOTHINGCONDITIONER. INT. CL. 3. REG. 7-20-2004.  
 2,865,325. FORCE FIELD STANDARD CHARACTER MARK. INT. CL. 1. REG. 7-20-2004.  
 2,865,328. TIC TAC CRYSTAL GEMS. INT. CL. 30. REG. 7-20-2004.  
 2,865,329. ALAMEDA RESEARCH GROUP. INT. CL. 42. REG. 7-20-2004.  
 2,865,330. SWISS BUSINESS TOOL YOUR POCKET OFFICE AND DESIGN. INT. CL. 8. REG. 7-20-2004.  
 2,865,332. JET-O-MATIC. INT. CL. 11. REG. 7-20-2004.  
 2,865,334. YOU'LL NEVER EAT ICE CREAM AGAIN. INT. CL. 35. REG. 7-20-2004.  
 2,865,336. FOODGROUP. INT. CL. 5. REG. 7-20-2004.  
 2,865,337. JUICE CREATIVE. INT. CLS. 41 AND 42. REG. 7-20-2004.  
 2,865,338. EFRAMES.COM. INT. CLS. 20 AND 40. REG. 7-20-2004.  
 2,865,342. INNOVEG. INT. CL. 31. REG. 7-20-2004.  
 2,865,343. THINSTATION. INT. CL. 9. REG. 7-20-2004.  
 2,865,344. THE INTELLIGENT SOLUTION. INT. CL. 9. REG. 7-20-2004.  
 2,865,346. DR. HANUKAH. INT. CL. 28. REG. 7-20-2004.  
 2,865,350. CHARTER SELECT. INT. CL. 36. REG. 7-20-2004.  
 2,865,352. ROSENBLUTH.COM. INT. CLS. 39 AND 42. REG. 7-20-2004.  
 2,865,356. MYMARKETPLACE. INT. CL. 35. REG. 7-20-2004.  
 2,865,358. GOLDEN OCCASIONS. INT. CL. 14. REG. 7-20-2004.  
 2,865,362. IMPACGUARD. INT. CL. 9. REG. 7-20-2004.  
 2,865,363. SYMPONY. INT. CL. 28. REG. 7-20-2004.  
 2,865,364. TCHICKOVSKY. INT. CL. 28. REG. 7-20-2004.  
 2,865,366. RENE PAIGE DESIGNS AND DESIGN. INT. CL. 42. REG. 7-20-2004.  
 2,865,367. GO OUTSIDE AND PLAY. INT. CLS. 16 AND 41. REG. 7-20-2004.  
 2,865,368. BIKE-TIME. INT. CL. 41. REG. 7-20-2004.  
 2,865,371. LTUNED (STYLIZED). INT. CLS. 7 AND 12. REG. 7-20-2004.  
 2,865,373. JEWELRYISIT. INT. CL. 35. REG. 7-20-2004.  
 2,865,374. VBG AND DESIGN. INT. CL. 16. REG. 7-20-2004.  
 2,865,375. HOMEOWNER'S ACCESS. INT. CL. 36. REG. 7-20-2004.  
 2,865,376. RELAXER ESSENTIALS. INT. CL. 3. REG. 7-20-2004.  
 2,865,377. MANAJIT (STYLIZED). INT. CL. 35. REG. 7-20-2004.  
 2,865,379. ELUCIDA. INT. CL. 42. REG. 7-20-2004.  
 2,865,382. DASH DOCK. INT. CL. 9. REG. 7-20-2004.  
 2,865,383. BMM AND DESIGN. INT. CL. 42. REG. 7-20-2004.  
 2,865,384. SWYPERS. INT. CL. 3. REG. 7-20-2004.  
 2,865,385. TRICAL. INT. CLS. 19 AND 22. REG. 7-20-2004.  
 2,865,387. E-TECH PRODUCTIVITY SOLUTION. INT. CLS. 35 AND 42. REG. 7-20-2004.  
 2,865,391. AIM AND DESIGN. INT. CLS. 6, 11, 12 AND 17. REG. 7-20-2004.  
 2,865,393. AGILITY WORKGROUP. INT. CL. 9. REG. 7-20-2004.  
 2,865,394. AIM. INT. CLS. 6, 11, 12 AND 17. REG. 7-20-2004.  
 2,865,395. HAPPY FAT MAN. INT. CL. 25. REG. 7-20-2004.  
 2,865,400. RUCKUS. INT. CL. 41. REG. 7-20-2004.  
 2,865,401. ACTIVIA CONSTELLATION. INT. CL. 38. REG. 7-20-2004.  
 2,865,405. FARMER'S VALLEY AND DESIGN. INT. CLS. 29 AND 31. REG. 7-20-2004.  
 2,865,409. OCEANA. INT. CL. 11. REG. 7-20-2004.  
 2,865,416. MUD-SSAGE. INT. CL. 42. REG. 7-20-2004.  
 2,865,417. LYMPHORAD. INT. CL. 5. REG. 7-20-2004.  
 2,865,418. DIVIDEND MILES ONLINE REWARDS. INT. CL. 35. REG. 7-20-2004.  
 2,865,419. VISIBLE RADIANCE. INT. CL. 3. REG. 7-20-2004.  
 2,865,420. SINGLE WAFER, SINGLE PLATFORM. INT. CL. 7. REG. 7-20-2004.  
 2,865,421. GLOBAL CONCERN ~ FOR ~ ALL SKIN PROBLEMS WORLD HEADQUARTERS ~ FOR ~ TREE RESIN NATR INC. AND DESIGN. INT. CL. 5. REG. 7-20-2004.  
 2,865,424. INFORMATION NERVOUS SYSTEM. INT. CL. 9. REG. 7-20-2004.  
 2,865,426. SKAM INDUSTRIES. INT. CL. 25. REG. 7-20-2004.  
 2,865,427. PEACE OF MIND DIAMOND. INT. CL. 35. REG. 7-20-2004.  
 2,865,428. NCOMMAND. INT. CL. 5. REG. 7-20-2004.  
 2,865,429. TINGUIS. INT. CL. 5. REG. 7-20-2004.  
 2,865,430. FASHION MODEL DIET. INT. CL. 5. REG. 7-20-2004.  
 2,865,431. SHEILA'S CHARDONNAY. INT. CL. 33. REG. 7-20-2004.  
 2,865,434. BAKERMAKS. INT. CLS. 9, 38 AND 42. REG. 7-20-2004.  
 2,865,435. OPTI'MALO. INT. CLS. 1, 5 AND 30. REG. 7-20-2004.  
 2,865,436. WORLDWIDE RESTAURANT CONCEPTS AND DESIGN. INT. CLS. 6, 21 AND 25. REG. 7-20-2004.  
 2,865,437. YOUR HOUSE IN A BAG. INT. CL. 16. REG. 7-20-2004.  
 2,865,440. CHECKFREE FRONTIER. INT. CL. 9. REG. 7-20-2004.  
 2,865,441. ASPEN CLEAN INDOOR AIR COMPANY AND DESIGN. INT. CL. 37. REG. 7-20-2004.  
 2,865,442. LIMONCELLO. INT. CL. 25. REG. 7-20-2004.  
 2,865,443. LUMETIQUE. INT. CL. 4. REG. 7-20-2004.  
 2,865,444. S3 SPECTRUM SECURITY SERVICES INTERNATIONAL A SPECTRUM MANAGEMENT COMPANY AND DESIGN. INT. CL. 37. REG. 7-20-2004.  
 2,865,450. SUN VALLEY AT SNOWBASIN. INT. CL. 25. REG. 7-20-2004.  
 2,865,452. EAGLE UNIVERSITY AND DESIGN. INT. CL. 41. REG. 7-20-2004.  
 2,865,453. REFRESCO APAGASED (STYLIZED). INT. CL. 32. REG. 7-20-2004.  
 2,865,454. HAPPY CAMPER. INT. CLS. 10 AND 42. REG. 7-20-2004.  
 2,865,455. MISCELLANEOUS DESIGN. INT. CLS. 7 AND 9. REG. 7-20-2004.  
 2,865,457. MISCELLANEOUS DESIGN. INT. CLS. 9, 16, 25 AND 28. REG. 7-20-2004.  
 2,865,459. S AND DESIGN. INT. CLS. 9, 16, 25 AND 28. REG. 7-20-2004.  
 2,865,460. NUMESA. INT. CL. 9. REG. 7-20-2004.  
 2,865,461. THE GRADUATE. INT. CL. 6. REG. 7-20-2004.  
 2,865,462. THE GRADUATE. INT. CL. 9. REG. 7-20-2004.  
 2,865,463. THE GRADUATE. INT. CL. 14. REG. 7-20-2004.  
 2,865,464. THE GRADUATE. INT. CL. 16. REG. 7-20-2004.  
 2,865,465. RICH ID RECORDS. INT. CL. 41. REG. 7-20-2004.  
 2,865,468. FAVID. INT. CL. 5. REG. 7-20-2004.  
 2,865,471. FIRSTPOINT. INT. CLS. 35 AND 38. REG. 7-20-2004.  
 2,865,478. AUGUSTA. INT. CL. 13. REG. 7-20-2004.  
 2,865,479. PORTAL-SPHERE. INT. CL. 40. REG. 7-20-2004.  
 2,865,482. BUDDY'S ALUMINUM DEPOT. INT. CL. 6. REG. 7-20-2004.

- 2,865,483. BOSOM BUDDY. INT. CL. 10. REG. 7-20-2004.  
 2,865,484. LONGBOROUGH. INT. CLS. 36, 37 AND 42. REG. 7-20-2004.  
 2,865,487. CHAR-BROIL CHARCOAL/GAS. INT. CL. 11. REG. 7-20-2004.  
 2,865,488. EVERYWHEREABLE. INT. CL. 9. REG. 7-20-2004.  
 2,865,489. MOLLY & MAX. INT. CL. 18. REG. 7-20-2004.  
 2,865,490. M.O.M. MOTHER'S OWN MILK. INT. CL. 41. REG. 7-20-2004.  
 2,865,492. SILKYTEXTURE. INT. CL. 3. REG. 7-20-2004.  
 2,865,493. QVANTAGE. INT. CL. 44. REG. 7-20-2004.  
 2,865,496. LCFE. INT. CL. 41. REG. 7-20-2004.  
 2,865,497. LCFE LIFETIME CARE FOR EVERYONE AND DESIGN. INT. CL. 41. REG. 7-20-2004.  
 2,865,499. CERTICOOOL AND DESIGN. INT. CLS. 7 AND 11. REG. 7-20-2004.  
 2,865,501. TAYLITE. INT. CL. 28. REG. 7-20-2004.  
 2,865,502. MAD JACK. INT. CL. 28. REG. 7-20-2004.  
 2,865,504. BRAZILIAN CHAMELEON AND DESIGN. INT. CLS. 25 AND 35. REG. 7-20-2004.  
 2,865,505. CAIRN AND DESIGN. INT. CLS. 16 AND 35. REG. 7-20-2004.  
 2,865,508. BUYYELLOW.. INT. CL. 35. REG. 7-20-2004.  
 2,865,510. ELLO CREATION SYSTEM AND DESIGN. INT. CL. 28. REG. 7-20-2004.  
 2,865,514. INDUSTRIAL STRENGTH INVESTMENT TOOLS. INT. CL. 36. REG. 7-20-2004.  
 2,865,518. MISCELLANEOUS DESIGN. INT. CL. 9. REG. 7-20-2004.  
 2,865,521. MANY MINUTES. INT. CLS. 16, 36 AND 38. REG. 7-20-2004.  
 2,865,522. MAJOR POWERS. INT. CL. 28. REG. 7-20-2004.  
 2,865,523. VIDEOBAHN (STYLIZED). INT. CL. 9. REG. 7-20-2004.  
 2,865,525. OLEODERMIS. INT. CL. 3. REG. 7-20-2004.  
 2,865,530. MOISTURE-MIX. INT. CL. 1. REG. 7-20-2004.  
 2,865,532. THE I.D.EAL WAY TO CHECK! AND DESIGN. INT. CL. 36. REG. 7-20-2004.  
 2,865,537. CEL-COOL AND DESIGN. INT. CL. 1. REG. 7-20-2004.  
 2,865,538. CEL-COOL. INT. CL. 1. REG. 7-20-2004.  
 2,865,540. COMPMIST. INT. CL. 10. REG. 7-20-2004.  
 2,865,541. CAPTIVA. INT. CL. 34. REG. 7-20-2004.  
 2,865,545. INGENOTYPING. INT. CLS. 42 AND 44. REG. 7-20-2004.  
 2,865,546. 401KELITE. INT. CL. 36. REG. 7-20-2004.  
 2,865,549. AU1100. INT. CL. 9. REG. 7-20-2004.  
 2,865,551. BURNHAM HYDRONICS. INT. CL. 11. REG. 7-20-2004.  
 2,865,552. AHMA HARDWARE SHOW. INT. CL. 35. REG. 7-20-2004.  
 2,865,553. FIRSTBEAT MARKETING. INT. CL. 35. REG. 7-20-2004.  
 2,865,556. LEARN2RIDE (STYLIZED). INT. CL. 12. REG. 7-20-2004.  
 2,865,557. AQUA CROCK. INT. CL. 11. REG. 7-20-2004.  
 2,865,563. HUG ME WHEN IT HURTS. INT. CL. 20. REG. 7-20-2004.  
 2,865,564. HIPICE. INT. CL. 14. REG. 7-20-2004.  
 2,865,569. IT'S YOUR VACATION, NOT OURS AND WE NEVER FORGET IT.. INT. CL. 43. REG. 7-20-2004.  
 2,865,570. DOLCEBABY. INT. CL. 31. REG. 7-20-2004.  
 2,865,573. MISCELLANEOUS DESIGN. INT. CL. 3. REG. 7-20-2004.  
 2,865,574. THERMOVISION SECURITY. INT. CL. 9. REG. 7-20-2004.  
 2,865,576. LA SABROSA 93.5 FM AND DESIGN. INT. CLS. 35, 38 AND 41. REG. 7-20-2004.  
 2,865,577. MISCELLANEOUS DESIGN. INT. CLS. 16, 25 AND 41. REG. 7-20-2004.  
 2,865,578. OASIS CAMPING...GEAR UP AND DESIGN. INT. CL. 22. REG. 7-20-2004.  
 2,865,579. I AM AN ASBURIAN. INT. CL. 41. REG. 7-20-2004.  
 2,865,581. COLORMERGE. INT. CL. 11. REG. 7-20-2004.  
 2,865,582. GRIND SPINE. INT. CL. 28. REG. 7-20-2004.  
 2,865,583. TRIUMPH. INT. CL. 9. REG. 7-20-2004.  
 2,865,584. SAG BAG (STYLIZED). INT. CL. 25. REG. 7-20-2004.  
 2,865,585. LIVE WELL. INT. CL. 36. REG. 7-20-2004.  
 2,865,588. PURELIFT. INT. CL. 3. REG. 7-20-2004.  
 2,865,594. NATIONAL COMMERCE FINANCIAL AND DESIGN. INT. CL. 36. REG. 7-20-2004.  
 2,865,596. MADISON SQ GARDEN BOXING HISTORY IS IN OUR CORNER AND DESIGN. INT. CL. 41. REG. 7-20-2004.  
 2,865,597. BOMBER BEARINGS. INT. CL. 28. REG. 7-20-2004.  
 2,865,598. WELL HEELED FOOT PRODUCTS. INT. CL. 3. REG. 7-20-2004.  
 2,865,600. MEDITASK AND DESIGN. INT. CL. 9. REG. 7-20-2004.  
 2,865,604. ORPHAN LINK. INT. CLS. 36 AND 42. REG. 7-20-2004.  
 2,865,606. FERTILE GROUND. INT. CL. 44. REG. 7-20-2004.  
 2,865,607. SAFEBASE (STYLIZED). INT. CL. 42. REG. 7-20-2004.  
 2,865,608. OFFICE XP. INT. CL. 16. REG. 7-20-2004.  
 2,865,609. SUNDAYS UNLIMITED. INT. CL. 25. REG. 7-20-2004.  
 2,865,613. JEWEL SPARKLE. INT. CL. 28. REG. 7-20-2004.  
 2,865,614. DOTTY PAWS (STYLIZED). INT. CL. 16. REG. 7-20-2004.  
 2,865,617. SYNERGEN. INT. CL. 1. REG. 7-20-2004.  
 2,865,619. AIRPHORIA (STYLIZED). INT. CL. 38. REG. 7-20-2004.  
 2,865,625. ZENTIME. INT. CL. 9. REG. 7-20-2004.  
 2,865,630. DENSELIGHT SEMICONDUCTORS AND DESIGN. INT. CL. 9. REG. 7-20-2004.  
 2,865,631. EMPLIFY. INT. CL. 9. REG. 7-20-2004.  
 2,865,634. Z ZOO WIRELESS AND DESIGN. INT. CL. 42. REG. 7-20-2004.  
 2,865,638. BROADCAST. INT. CL. 9. REG. 7-20-2004.  
 2,865,640. CAST-A-SPELL. INT. CL. 28. REG. 7-20-2004.  
 2,865,641. CHESTERWHITE. INT. CL. 41. REG. 7-20-2004.  
 2,865,643. THE INNOVATORS OF FILING TECHNOLOGY. INT. CLS. 37 AND 42. REG. 7-20-2004.  
 2,865,645. LIEN THAO TRA (STYLIZED). INT. CL. 30. REG. 7-20-2004.  
 2,865,647. DANCE NIGHT. INT. CL. 28. REG. 7-20-2004.  
 2,865,648. BEINMONTANA.COM AND DESIGN. INT. CL. 35. REG. 7-20-2004.  
 2,865,649. ADVANCED PROTECTIVE TRAINING & INTELLIGENCE, LLC AND DESIGN. INT. CL. 41. REG. 7-20-2004.  
 2,865,650. HW-1. INT. CL. 28. REG. 7-20-2004.  
 2,865,651. MONTICELLO DELANEY RIFLES M D AND DESIGN. INT. CL. 25. REG. 7-20-2004.  
 2,865,655. BIOACTIVE MODULATORS. INT. CL. 3. REG. 7-20-2004.  
 2,865,656. VIA 3 VIACK AND DESIGN. INT. CL. 9. REG. 7-20-2004.  
 2,865,658. WHAT YOU'VE HEARD IS TRUE. INT. CL. 36. REG. 7-20-2004.  
 2,865,659. ETADEL. INT. CL. 9. REG. 7-20-2004.  
 2,865,660. BUSINESSID. INT. CL. 35. REG. 7-20-2004.  
 2,865,663. PRO-SHIELD AUTO GLASS AND DESIGN. INT. CL. 37. REG. 7-20-2004.  
 2,865,664. T MULTITHEREX AND DESIGN. INT. CL. 10. REG. 7-20-2004.  
 2,865,671. DRAGON WAGONS. INT. CL. 28. REG. 7-20-2004.  
 2,865,672. B-DAY. INT. CL. 28. REG. 7-20-2004.  
 2,865,673. ARM-ATTACK. INT. CL. 28. REG. 7-20-2004.  
 2,865,674. SURROUNDED BY MORONS. INT. CL. 25. REG. 7-20-2004.  
 2,865,675. SURROUNDED BY MORONS. INT. CL. 21. REG. 7-20-2004.  
 2,865,676. BE MY VALENTINE AND DESIGN. INT. CL. 25. REG. 7-20-2004.  
 2,865,677. DESTINATION SEMINARS. INT. CL. 41. REG. 7-20-2004.  
 2,865,679. SPEND IT FAST. INT. CL. 41. REG. 7-20-2004.  
 2,865,681. ACTION OFFROAD (STYLIZED). INT. CL. 35. REG. 7-20-2004.  
 2,865,686. IBI ONLINE. INT. CL. 35. REG. 7-20-2004.

- 2,865,689. OXYBITE. INT. CL. 5. REG. 7-20-2004.  
 2,865,690. PINK PIRANHA AND DESIGN. INT. CL. 25. REG. 7-20-2004.  
 2,865,692. CLEO B'S. INT. CL. 30. REG. 7-20-2004.  
 2,865,693. NIDB. INT. CL. 36. REG. 7-20-2004.  
 2,865,695. I CAN'T DO IT ALL. INT. CL. 25. REG. 7-20-2004.  
 2,865,698. DEZI. INT. CL. 28. REG. 7-20-2004.  
 2,865,699. ANNIE BIOTIC. INT. CL. 28. REG. 7-20-2004.  
 2,865,701. OWNERK. INT. CL. 36. REG. 7-20-2004.  
 2,865,702. WILLIAM E. POOLE. INT. CL. 27. REG. 7-20-2004.  
 2,865,704. COOL COMFORT. INT. CL. 25. REG. 7-20-2004.  
 2,865,705. ASHLEY DEARBORN. INT. CL. 25. REG. 7-20-2004.  
 2,865,706. SP 245. INT. CL. 12. REG. 7-20-2004.  
 2,865,707. COLLEGEOLGY. INT. CL. 41. REG. 7-20-2004.  
 2,865,708. CLEANER CITIES CLEANER OCEANS. INT. CL. 36. REG. 7-20-2004.  
 2,865,709. CLEANER CITIES CLEANER STREAMS. INT. CL. 36. REG. 7-20-2004.  
 2,865,710. THE SEASONED GRILL. INT. CLS. 8 AND 21. REG. 7-20-2004.  
 2,865,711. SIENNA HARVEST. INT. CL. 21. REG. 7-20-2004.  
 2,865,712. DISNEY HAND. INT. CL. 36. REG. 7-20-2004.  
 2,865,717. TURN IT UP. INT. CL. 9. REG. 7-20-2004.  
 2,865,718. FIVE FOOT THICK. INT. CL. 41. REG. 7-20-2004.  
 2,865,722. SOUTH CROSS CATTLE. INT. CL. 31. REG. 7-20-2004.  
 2,865,723. I COLOR I AND DESIGN. INT. CL. 9. REG. 7-20-2004.  
 2,865,724. BREEZE. INT. CL. 20. REG. 7-20-2004.  
 2,865,725. MANDUCA TRADING. INT. CL. 36. REG. 7-20-2004.  
 2,865,726. SPINEJET. INT. CL. 10. REG. 7-20-2004.  
 2,865,727. ATHLETICUTS. INT. CL. 44. REG. 7-20-2004.  
 2,865,728. WONDERBAG. INT. CLS. 28 AND 30. REG. 7-20-2004.  
 2,865,733. EFFETTI. INT. CLS. 35 AND 42. REG. 7-20-2004.  
 2,865,735. RANDOM ACCESS. INT. CL. 25. REG. 7-20-2004.  
 2,865,739. USA COLLEGECONNECT THE 529 PLAN LINKING YOU TO THE FUTURE (STYLIZED). INT. CL. 36. REG. 7-20-2004.  
 2,865,742. GO BEYOND DIAL TONE. INT. CL. 9. REG. 7-20-2004.  
 2,865,743. THE ART OF BELLY DANCE. INT. CL. 9. REG. 7-20-2004.  
 2,865,744. HYDROSERVANT. INT. CL. 9. REG. 7-20-2004.  
 2,865,745. LOADBLAZER. INT. CL. 12. REG. 7-20-2004.  
 2,865,748. OM. INT. CL. 34. REG. 7-20-2004.  
 2,865,750. FASTPRIN. INT. CL. 5. REG. 7-20-2004.  
 2,865,751. BEAMIT. INT. CL. 9. REG. 7-20-2004.  
 2,865,757. MIAMOR. INT. CL. 3. REG. 7-20-2004.  
 2,865,760. STUMP THE EXPERTS. INT. CL. 41. REG. 7-20-2004.  
 2,865,764. HEART, AWAKENED. INT. CL. 3. REG. 7-20-2004.  
 2,865,766. JEFF. INT. CL. 16. REG. 7-20-2004.  
 2,865,767. SJC. INT. CL. 14. REG. 7-20-2004.  
 2,865,770. CERTIFIED LIFE PLANNER. INT. CLS. 16 AND 41. REG. 7-20-2004.  
 2,865,771. KS. INT. CL. 25. REG. 7-20-2004.  
 2,865,781. J. FARGO'S. INT. CL. 43. REG. 7-20-2004.  
 2,865,782. SUPER TRANSFORMING GROWTH FACTOR. INT. CL. 5. REG. 7-20-2004.  
 2,865,783. NRI TOURS. INT. CLS. 39 AND 43. REG. 7-20-2004.  
 2,865,784. CASA MEXICANA. INT. CLS. 37 AND 42. REG. 7-20-2004.  
 2,865,786. PEERSTORAGE. INT. CL. 9. REG. 7-20-2004.  
 2,865,787. STOP GARBAGE ODOR AND DESIGN. INT. CL. 5. REG. 7-20-2004.  
 2,865,788. NETWORK BUSINESS PROCESS ARCHITECTURE. INT. CL. 42. REG. 7-20-2004.  
 2,865,789. HEAT/COOL. INT. CL. 9. REG. 7-20-2004.  
 2,865,790. MISCELLANEOUS DESIGN. INT. CL. 25. REG. 7-20-2004.  
 2,865,792. OTTICA VENETA. INT. CL. 9. REG. 7-20-2004.  
 2,865,793. SANTIAGO CELEBRA. INT. CL. 30. REG. 7-20-2004.  
 2,865,795. WORLD ALCOHOL RACERS. INT. CL. 41. REG. 7-20-2004.  
 2,865,797. WRAP & PACK. INT. CL. 16. REG. 7-20-2004.  
 2,865,798. WORLD JEWISH DIGEST. INT. CL. 16. REG. 7-20-2004.  
 2,865,801. POT STICKER STIR FRY FEAST. INT. CL. 29. REG. 7-20-2004.  
 2,865,803. BARRAS'. INT. CL. 29. REG. 7-20-2004.  
 2,865,805. MEMBERS' AUTO CENTER. INT. CL. 36. REG. 7-20-2004.  
 2,865,806. PERMANENT PLACEMENT SOLUTIONS. INT. CL. 35. REG. 7-20-2004.  
 2,865,807. CHIROPRACTIC PLANS OF AMERICA. INT. CL. 35. REG. 7-20-2004.  
 2,865,809. COOPERATIVE OF AMERICAN PHYSICIANS INSURANCE COMPANY. INT. CL. 36. REG. 7-20-2004.  
 2,865,810. P NUT FARM. INT. CL. 25. REG. 7-20-2004.  
 2,865,812. ASIAN CAR SEX. INT. CL. 9. REG. 7-20-2004.  
 2,865,814. SATURATION BRANDING. INT. CL. 35. REG. 7-20-2004.  
 2,865,815. MISCELLANEOUS DESIGN. INT. CL. 12. REG. 7-20-2004.  
 2,865,816. REALITY MINING. INT. CL. 35. REG. 7-20-2004.  
 2,865,817. SUPERIOR SERVICE. INT. CL. 37. REG. 7-20-2004.  
 2,865,818. AMERICA'S OLDEST HOMEBUILDER. INT. CL. 37. REG. 7-20-2004.  
 2,865,819. LOCH LLOYD TRAVEL CONSULTANTS. INT. CL. 35. REG. 7-20-2004.  
 2,865,820. KIDS KLASSIC KOSTUMES. INT. CL. 25. REG. 7-20-2004.  
 2,865,821. FULL VALUE THROUGH JESUS. INT. CL. 20. REG. 7-20-2004.  
 2,865,822. WAKE-UP CALL. INT. CL. 42. REG. 7-20-2004.  
 2,865,823. ULTRA PURE WATER MANAGEMENT SYSTEM. INT. CL. 11. REG. 7-20-2004.  
 2,865,824. BOOT SERVICES. INT. CL. 9. REG. 7-20-2004.  
 2,865,825. FOGARTY. INT. CLS. 20 AND 24. REG. 7-20-2004.  
 2,865,826. BROADBAND WIRELESS ALLIANCE. INT. CL. 42. REG. 7-20-2004.  
 2,865,827. YOUR HOUSTON BUSINESS. INT. CLS. 16 AND 41. REG. 7-20-2004.  
 2,865,828. BOXSTRETCHER. INT. CL. 12. REG. 7-20-2004.  
 2,865,829. SALESINCENTIVEMANAGER. INT. CL. 35. REG. 7-20-2004.  
 2,865,830. DC-HIPAA. INT. CLS. 41 AND 42. REG. 7-20-2004.  
 2,865,832. ASSISTING CLIENTS IN THE ACCUMULATION AND PRESERVATION OF WEALTH. INT. CLS. 36 AND 42. REG. 7-20-2004.  
 2,865,834. TORREALBA. INT. CL. 33. REG. 7-20-2004.  
 2,865,837. PROJECT CHILDSAFE. INT. CL. 35. REG. 7-20-2004.  
 2,865,839. AMERICAN VINAIGRETTE. INT. CL. 30. REG. 7-20-2004.  
 2,865,840. SIMULATED DECISION MODELING. INT. CL. 35. REG. 7-20-2004.  
 2,865,848. STRIP 'N STIC. INT. CL. 16. REG. 7-20-2004.  
 2,865,852. NONPRIME PLUS. INT. CL. 36. REG. 7-20-2004.  
 2,865,853. CALIFORNIA SUPERCROSS. INT. CL. 41. REG. 7-20-2004.  
 2,865,854. MAINE MUNCHIES (STYLIZED). INT. CL. 29. REG. 7-20-2004.  
 2,865,856. MINNESOTACARS.COM. INT. CL. 35. REG. 7-20-2004.  
 2,865,857. AYLES. INT. CL. 33. REG. 7-20-2004.  
 2,868,318. EUTELSAT. INT. CLS. 9, 35, 37, 39 AND 41 ONLY. REG. 8-3-2004.  
 2,868,319. MISCELLANEOUS DESIGN. INT. CLS. 9, 35, 37, 39 AND 41 ONLY. REG. 8-3-2004.  
 2,871,281. HAYDEN HOMES AND DESIGN. INT. CL. 37. REG. 8-10-2004.  
 2,873,142. MOLMIND. INT. CLS. 7 AND 9 ONLY. REG. 8-17-2004.  
 2,879,960. MOLLERTECH. INT. CL. 18 ONLY. REG. 8-31-2004.  
 2,882,304. MOLLERGROUP M AND DESIGN. INT. CL. 18 ONLY. REG. 9-7-2004.  
 2,894,018. OH! BEANS. INT. CL. 25 ONLY. REG. 10-19-2004.

- |  |   |
|--|---|
| 2,918,420. SALMON NATION. INT. CLS. 35 AND 41 ONLY. REG. 1-18-2005.                  | 3,019,864. INTEGRITY'S IWORSHIP AND DESIGN. INT. CL. 16 ONLY. REG. 11-29-2005.        |
| 2,919,392. HAIRDREAMS. INT. CL. 7 ONLY. REG. 1-18-2005.                              | 3,047,163. OGGETTI. INT. CLS. 14, 16 AND 28 ONLY. REG. 1-24-2006.                     |
| 2,919,499. GARDEN TREASURES. INT. CLS. 8 AND 25 ONLY. REG. 1-18-2005.                | 3,052,246. NATIONAL DATACARE CORPORATION AND DESIGN. INT. CL. 9 ONLY. REG. 1-31-2006. |
| 2,920,129. VIRTUAL VANTAGE. INT. CLS. 9 AND 16 ONLY. REG. 1-18-2005.                 |   |
| 2,925,005. CANOPY FACTORY. INT. CL. 19 ONLY. REG. 2-8-2005.                          |   |
| 2,925,160. MISCELLANEOUS DESIGN. INT. CLS. 35 AND 42 ONLY. REG. 2-8-2005.            |   |
| 2,925,577. HEAVENLY BATH. INT. CLS. 3 AND 11 ONLY. REG. 2-8-2005.                    |   |
| 2,926,604. DICK IDOL. INT. CLS. 6, 16, 24 AND 31 ONLY. REG. 2-15-2005.               |   |
| 2,926,860. RALLIART. INT. CLS. 35, 37 AND 41 ONLY. REG. 2-15-2005.                   |   |
| 2,927,074. WOOLRICH. INT. CL. 24 ONLY. REG. 2-15-2005.                               |   |
| 2,927,773. MERGE-MAXX. INT. CLS. 8 AND 12 ONLY. REG. 2-22-2005.                      |   |
| 2,929,280. MISCELLANEOUS DESIGN. INT. CLS. 16, 24 AND 31 ONLY. REG. 3-1-2005.        |   |
| 2,930,247. AROSHIFT. INT. CL. 1 ONLY. REG. 3-8-2005.                                 |   |
| 2,937,218. PATENT LETTER NEWS. INT. CL. 42 ONLY. REG. 4-5-2005.                      |   |
| 2,944,455. ART HOME AND DESIGN. INT. CL. 5 ONLY. REG. 4-26-2005.                     |   |
| 2,947,126. GLOBAL DECOR. INT. CLS. 3 AND 11 ONLY. REG. 5-10-2005.                    |   |
| 2,973,887. THE JOY OF GARDENING. INT. CLS. 6, 9, 11, 14 AND 19 ONLY. REG. 7-19-2005. |   |
|  | 3,177,601. THE ORIGINAL PIZZA PUCKS. INT. CL. 43. REG. 11-28-2006.                    |

---

**SECTION 18**

---

**INADVERTENTLY ISSUED REGISTRATION NUMBERS**

\* \* \* \* \*

# TRADEMARK REGISTRATIONS AMENDED, CORRECTED, ETC.

The designation "U.S. Cl." appearing in this section refers to the U.S. class in effect prior to Sep. 1, 1973 rather than the international class which applies to applications filed on or after that date. For adoption of international classification see notice in the OFFICIAL GAZETTE of Jun. 26, 1973 (911 O.G. TM 210).

Any change to the registration will be indicated at the bottom of each entry under ELEMENTS AMENDED, CORRECTED OR RESTRICTED. With the exception of changes to the goods and services, additions to the registration will appear in asterisks and deletions of the registration will appear in brackets. Elements which are only changed will be listed with no punctuation. As to the goods/services statement, amendments to the goods/services will appear in asterisks and deletions will appear in brackets. In addition if any change to the goods/services occurs, the element "Goods/Services" will be listed under ELEMENTS AMENDED, CORRECTED OR RESTRICTED.

1,146,999. REG. 2-17-1981. ALLERDERM LABORATORIES, INC. (CALIFORNIA CORPORATION) 3400 EAST MCDOWELL, PHOENIX, AZ. 85008, SN 73-221,569. FILED 6-28-1979. PRINCIPAL REGISTER.

FOR VIDEO [ CASSETTE ] \* DISC \* DISTRIBUTION SERVICES ON A REVENUE-SHARING OR USE-FEE BASIS.  
FIRST USE 5-12-1988; IN COMMERCE 5-12-1988.

## U-LACTIN

ELEMENTS AMENDED  
GOODS/SERVICES

THE MARK CONSISTS OF STANDARD CHARACTERS WITHOUT CLAIM TO ANY PARTICULAR FONT, STYLE, SIZE, OR COLOR.  
INT. CL. 3/U.S. CL. 51  
FOR SKIN MOISTURIZING LOTION.  
FIRST USE 1-11-1979; IN COMMERCE 1-11-1979.

1,705,595. REG. 8-4-1992. COUSINS SUBMARINES, INC. (WISCONSIN CORPORATION) N83 W 13400 LEON ROAD, MENOMONEE FALLS, WI, 53051, SN 74-154,128. FILED 4-4-1991. PRINCIPAL REGISTER.

ELEMENTS AMENDED  
\*ASSIGNMENT/NAME CHANGE\*  
OWNER NAME  
OWNER ADDRESS  
MARK



The logo for Cousins SUBS features the word "Cousins" in a large, bold, sans-serif font, with "SUBS" in a smaller, bold, sans-serif font directly below it.

1,423,614. REG. 1-6-1987. CUSTOM FIREPLACE LTD., INC. (MISSOURI CORPORATION) P.O. BOX 188, #1 WAGNER INDUSTRIAL PARK, ST. CLAIR, MO. 63077, SN 73-602,480. FILED 6-5-1986. PRINCIPAL REGISTER.

OWNER OF U.S. REG. NO. 1,165,909.  
NO CLAIM IS MADE TO THE EXCLUSIVE RIGHT TO USE "SUBS", APART FROM THE MARK AS SHOWN.  
INT. CL. 42/U.S. CL. 100  
FOR RESTAURANT SERVICES.  
FIRST USE 11-7-1990, FIRST USED IN ANOTHER FORM ON JUNE 19, 1972; IN COMMERCE 12-7-1990.

## E-Z-LOCK

ELEMENTS AMENDED  
MARK

INT. CL. 6/U.S. CL. 13  
FOR GUTTER SCREENING.  
FIRST USE 4-25-1986; IN COMMERCE 5-8-1986.

ELEMENTS CORRECTED  
OWNER NAME  
OWNER ADDRESS

2,215,990. REG. 1-5-1999. 11040 HOLDINGS, INC. (PENNSYLVANIA CORPORATION) 11040 PARKER DRIVE, IRWIN, PA, 15642, SN 75-325,269. FILED 7-16-1997. PRINCIPAL REGISTER.

1,594,594. REG. 5-1-1990. RENTRAK CORPORATION (OREGON CORPORATION) ONE AIRPORT CENTER, 7700 N.E. AMBASSADOR PLACE, PORTLAND, OR. 97220, SN 73-731,549. FILED 5-31-1988. PRINCIPAL REGISTER.



The logo for Innovative Carbide LLC features a stylized graphic of a carbide bit on the left, followed by the words "Innovative Carbide LLC" in a bold, sans-serif font.

## RENTRAK

NO CLAIM IS MADE TO THE EXCLUSIVE RIGHT TO USE "CARBIDE LLC", APART FROM THE MARK AS SHOWN.

INT. CL. 41/U.S. CLS. 100, 101 AND 107

TM 1438

THE MARK CONSISTS OF THE WORDING "INNOVATIVE" OVER "CARBIDE LLC" TO THE LEFT OF WHICH IS A STYLIZED DESIGN OF A CYLINDER AND PARTIAL CYLINDER EVOCATIVE OF THE LETTERS "I" AND "C".  
INT. CL. 6/U.S. CLS. 2, 12, 13, 14, 23, 25 AND 50  
FOR METAL MOLDS, NAMELY, TUNGSTEN CARBIDE PREFORMS FOR DIES AND WEARS.  
FIRST USE 4-2-1992; IN COMMERCE 4-2-1992.

ELEMENTS AMENDED  
MARK  
DISCLAIMER

FOR ENTERTAINMENT SERVICES IN THE NATURE OF LIVE BASEBALL EXHIBITIONS AND BASEBALL EXHIBITIONS RENDERED THROUGH [RADIO,] TELEVISION, AND VIA GLOBAL COMPUTER NETWORK; LIVE PERFORMANCES BY COSTUMED CHARACTERS AND PERFORMANCES FEATURING COSTUMED OR CARTOON CHARACTERS EXHIBITED OVER TELEVISION, SATELLITE AND VIDEO MEDIA.  
FIRST USE 4-5-1991; IN COMMERCE 4-5-1991.

ELEMENTS CORRECTED  
OWNER NAME

2,382,993. REG. 9-5-2000. NINTENDO OF AMERICA INC. (WASHINGTON CORPORATION) 4600 150TH AVENUE NE, REDMOND, WA, 98052, SN 75-767,404. FILED 8-4-1999. PRINCIPAL REGISTER.

2,386,358. REG. 9-12-2000. MANNATECH, INCORPORATED (TEXAS CORPORATION) 600 SOUTH ROYAL LANE, SUITE 200, COPPELL, TX, 75019, SN 75-569,627. FILED 10-14-1998. PRINCIPAL REGISTER.

# POKÉMON

## AMBROSTART

THE MARK CONSISTS OF STANDARD CHARACTERS WITHOUT CLAIM TO ANY PARTICULAR FONT, STYLE, SIZE, OR COLOR.  
OWNER OF U.S. REG. NO. 2,297,050.  
INT. CL. 41/U.S. CLS. 100, 101 AND 107  
FOR PROVIDING A WEB SITE FEATURING ENTERTAINMENT INFORMATION IN THE FIELDS OF ELECTRONIC GAME PROGRAMS, ELECTRONIC GAME PRODUCTS, AND OTHER ENTERTAINMENT TOPICS RELATED TO ELECTRONIC GAME PROGRAMS AND PRODUCTS.  
FIRST USE 5-0-1998; IN COMMERCE 5-0-1998.

INT. CL. 5/U.S. CLS. 6, 18, 44, 46, 51 AND 52  
FOR DIETARY AND NUTRITIONAL SUPPLEMENTS.  
FIRST USE 10-0-1998; IN COMMERCE 10-0-1998.

ELEMENTS CORRECTED  
OWNER NAME

ELEMENTS AMENDED  
MARK

2,411,357. REG. 12-5-2000. HOME PRODUCTS INTERNATIONAL - NORTH AMERICA, INC. (DELAWARE CORPORATION) 4501 WEST 47TH STREET, CHICAGO, IL, 60632, SN 75-669,184. FILED 3-26-1999. PRINCIPAL REGISTER.

## HOMZ

2,384,821. REG. 9-12-2000. MILWAUKEE BREWERS BASEBALL CLUB, LIMITED PARTNERSHIP (WISCONSIN LIMITED PARTNERSHIP) MILLER PARK, ONE BREWERS WAY, MILWAUKEE, WI, 53214, SN 75-603,916. FILED 12-11-1998. PRINCIPAL REGISTER.

INT. CL. 21/U.S. CLS. 2, 13, 23, 29, 30, 33, 40 AND 50  
FOR KITCHEN AND BATHROOM ACCESSORIES, NAMELY, TOWEL BARS, SOAP DISHES, TOOTHBRUSH HOLDERS, TUMBLERS, ICE TRAYS, BUCKETS, UTILITY BASKETS, HOLDERS FOR USE IN SHOWERS AND BATHTUBS, TUMBLER HOLDERS, TOWEL RINGS, TISSUE HOLDERS, SHOWER CADDIES, PORTABLE HOUSEHOLD CONTAINERS, HOLDERS FOR PLATES AND CUPS, AND SPICE RACKS.  
FIRST USE 8-1-1999; IN COMMERCE 8-1-1999.

ELEMENTS CORRECTED  
OWNER NAME



2,420,497. REG. 1-16-2001. RIDGID, INC. (DELAWARE CORPORATION) 1209 ORANGE STREET, CORPORATE TRUST CENTER, WILMINGTON, DE, 19801, SN 75-572,110. FILED 10-16-1998. PRINCIPAL REGISTER.

# RIDGID



THE MARK CONSISTS OF A TWO-DIMENSIONAL DEPICTION OF A THREE-DIMENSIONAL COSTUMED CHARACTER.  
INT. CL. 41/U.S. CLS. 100, 101 AND 107

OWNER OF U.S. REG. NOS. 419,190, 1,717,537 AND OTHERS.

THE BAR UNDERNEATH THE WORD MARK "RIDGID" IS LINED FOR THE COLOR RED, AND COLOR IS CLAIMED AS A FEATURE OF THE MARK.

INT. CL. 7/U.S. CLS. 13, 19, 21, 23, 31, 34 AND 35  
 FOR POWER TOOLS [ AND ELECTRIC MOTORS THEREFOR ], NAMELY, SAWS, COMPRESSORS, DRILL PRESSES, DRILLS, ELECTRIC GENERATORS, JOINERS, PLANERS, LATHES, GRINDERS, SANDERS, ROUTERS, AND REPLACEMENT PARTS THEREFOR; \* ELECTRIC MOTORS BEING COMPONENT PARTS OF POWER TOOLS; \* VACUUM CLEANERS AND REPLACEMENT PARTS THEREFOR.

FIRST USE 7-16-1998; IN COMMERCE 7-16-1998.  
 INT. CL. 11/U.S. CLS. 13, 21, 23, 31 AND 34  
 FOR SEPARATORS FOR THE CLEANING AND PURIFICATION OF AIR.  
 FIRST USE 3-14-1998; IN COMMERCE 3-14-1998.

ELEMENTS AMENDED  
 GOODS/SERVICES



2,420,623. REG. 1-16-2001. CUSTOM MATERIALS, INC. (OHIO CORPORATION) 16865 PARK CIRCLE DRIVE, CHAGRIN FALLS, OH, 440239904, SN 75-659,079. FILED 3-12-1999. PRINCIPAL REGISTER.



INT. CL. 9/U.S. CLS. 21, 23, 26, 36 AND 38  
 FOR STRUCTURAL PARTS OF ELECTRICAL TRANSFORMERS, NAMELY, PRESSURE RINGS, AND TANK WALL SHIELDING; ELECTRIC FUSE HOLDERS ELECTRICAL TRANSFORMERS; ELECTRICAL APERTURE BUSHINGS.

FIRST USE 6-0-1993; IN COMMERCE 6-0-1993.  
 INT. CL. 17/U.S. CLS. 1, 5, 12, 13, 35 AND 50  
 FOR ELECTRICAL INSULATION CONSISTING OF SHEETS MADE OF THERMOPLASTIC, PAPER AND PAPERBOARD AND SHEETING MADE OF RESIN BASED LIQUIDS; RUBBER GASKETS.  
 FIRST USE 6-0-1993; IN COMMERCE 6-0-1993.

ELEMENTS AMENDED  
 MARK

2,431,581. REG. 2-27-2001. INFORMATION SYSTEMS AUDIT AND CONTROL ASSOCIATION (CALIFORNIA NOT-FOR-PROFIT CORPORATION) 3701 ALGONQUIN ROAD, SUITE 1010, ROLLING MEADOWS, IL, 60008, SN 75-942,505. FILED 3-13-2000. PRINCIPAL REGISTER.



NO CLAIM IS MADE TO THE EXCLUSIVE RIGHT TO USE "IT GOVERNANCE INSTITUTE", APART FROM THE MARK AS SHOWN.

INT. CL. 16/U.S. CLS. 2, 5, 22, 23, 29, 37, 38 AND 50  
 FOR PRINTED INSTRUCTIONAL, EDUCATIONAL AND TEACHING MATERIAL IN THE AREA OF INFORMATION TECHNOLOGY FOR BUSINESS MANAGEMENT, CONSULTATION AND AUDITING OF INFORMATION SYSTEMS.  
 FIRST USE 7-20-1999; IN COMMERCE 7-20-1999.

ELEMENTS AMENDED  
 MARK



2,431,771. REG. 2-27-2001. ZIRKELBACH CONSTRUCTION, INC. (FLORIDA CORPORATION) 1415 10TH STREET WEST, PALMETTO, FL, 34221, SN 76-026,356. FILED 4-14-2000. PRINCIPAL REGISTER.



INT. CL. 37/U.S. CLS. 100, 103 AND 106  
 FOR RESIDENTIAL AND COMMERCIAL BUILDING CONSTRUCTION SERVICES; AND REAL ESTATE DEVELOPMENT SERVICES.  
 FIRST USE 8-26-1999; IN COMMERCE 8-26-1999.

ELEMENTS CORRECTED  
 OWNER NAME  
 OWNER ADDRESS  
 MARK



2,448,513. REG. 5-1-2001. D. W. SIMPSON & CO. (ILLINOIS CORPORATION) 1800 WEST LARCHMONT AVE. SUITE 3E, CHICAGO, IL, 60613, SN 75-790,875. FILED P.R. 9-2-1999; AM. S.R. 8-21-2000. SUPPLEMENTAL REGISTER.

## 4INSURANCEJOBS.COM

INT. CL. 35/U.S. CLS. 100, 101 AND 102  
FOR RECRUITING SERVICES FOR THE INSURANCE INDUSTRY PRIMARILY VIA A GLOBAL COMPUTER INFORMATION NETWORK.  
FIRST USE 7-14-1999; IN COMMERCE 7-14-1999.

ELEMENTS CORRECTED  
OWNER NAME

---

2,488,778. REG. 9-11-2001. HORSEWARE PRODUCTS LTD. (IRELAND LIMITED COMPANY) FINNABAIR INDUSTRIAL ESTATE, DUNDALK, COUNTY LOUTH, IRELAND., SN 75-778,724. FILED 8-18-1999. PRINCIPAL REGISTER.

## HORSEWARE

INT. CL. 25/U.S. CLS. 22 AND 39  
FOR BREECHES (FOR WEAR), GAITERS, LEGGINGS, PANTS, OVERALLS, SMOCKS, PULLOVERS, COATS, OVERCOATS, TOPCOATS, JACKETS; HALF-BOOTS, OVERSHOES, SHOES, SPORTS SHOES; CAPS, HATS, AND HOODS.  
FIRST USE 0-0-1996; IN COMMERCE 0-0-2000.

ELEMENTS CORRECTED  
GOODS/SERVICES

---

2,500,758. REG. 10-23-2001. TOYOTA JIDOSHA KABUSHIKI KAISHA (JAPAN CORPORATION), TA TOYOTA MOTOR CORPORATION, 1, TOYOTA-CHO, TOYOTA-SHI, AICHI 471, JAPAN., SN 75-684,736. FILED 4-19-1999. PRINCIPAL REGISTER.

## IS 300

NO CLAIM IS MADE TO THE EXCLUSIVE RIGHT TO USE "300", APART FROM THE MARK AS SHOWN.

INT. CL. 12/U.S. CLS. 19, 21, 23, 31, 35 AND 44  
FOR [ MOTOR CARS AND STRUCTURAL PARTS THEREOF ] \* PRE-OWNED AUTOMOBILES TESTED, RECONDITIONED AND APPROVED BY THE REGISTRANT'S AUTHORIZED FRANCHISED DEALERS AND SOLD BY THE AUTHORIZED FRANCHISED DEALERS \*.

FIRST USE 6-1-2000; IN COMMERCE 6-1-2000.

ELEMENTS AMENDED  
GOODS/SERVICES

2,507,353. REG. 11-13-2001. KLUTZ (CALIFORNIA CORPORATION) 450 LAMBERT AVENUE, PALO ALTO, CA, 94306, SN 75-414,646. FILED 1-7-1998. PRINCIPAL REGISTER.

## ROCKET

INT. CL. 28/U.S. CLS. 22, 23, 38 AND 50  
FOR YO-YOS.  
FIRST USE 5-1-1998; IN COMMERCE 5-1-1998.

ELEMENTS CORRECTED  
OWNER NAME

---

2,512,272. REG. 11-27-2001. TEMPLE UNIVERSITY - OF THE COMMONWEALTH SYSTEM OF HIGHER EDUCATION (PENNSYLVANIA NON-PROFIT CORPORATION) 1330 POLETT WALK, SUITE 300, PHILADELPHIA, PA, 19122, SN 76-124,059. FILED 9-6-2000. PRINCIPAL REGISTER.

## OWLNET

INT. CL. 41/U.S. CLS. 100, 101 AND 107  
FOR INTERNET WEBSITE FEATURING ONLINE COURSE REGISTRATION, OFFICIAL STUDENT RECORDS, AND INFORMATION ON COURSES OF INSTRUCTION AT THE UNIVERSITY LEVEL.  
FIRST USE 1-6-2000; IN COMMERCE 1-6-2000.

ELEMENTS CORRECTED  
ENTITY

---

2,547,741. REG. 3-12-2002. ZURICH AMERICAN INSURANCE COMPANY (NEW YORK CORPORATION) 1400 AMERICAN LANE, SCHAUMBURG, IL, 60196, SN 75-604,691. FILED 12-14-1998. PRINCIPAL REGISTER.



NO CLAIM IS MADE TO THE EXCLUSIVE RIGHT TO USE "DIVERSIFIED SPECIALTY RISKS, INC.", APART FROM THE MARK AS SHOWN.

INT. CL. 36/U.S. CLS. 100, 101 AND 102

FOR INSURANCE SERVICES, NAMELY, INSURANCE ADMINISTRATION, INSURANCE BROKERAGE, INSURANCE AGENCY, INSURANCE CLAIMS ADMINISTRATION AND INSURANCE UNDERWRITING IN THE FIELD OF ACCIDENT, FIRE, LIFE, MARINE, MEDICAL, WORKMEN'S COMPENSATION, PROPERTY AND CASUALTY.

FIRST USE 1-1-1999; IN COMMERCE 1-1-1999.

ELEMENTS CORRECTED  
\*ASSIGNMENT/NAME CHANGE\*

CITIZENSHIP

2,904,037. REG. 11-23-2004. GOVERNMENT OF THE NORTH-WEST TERRITORIES, THE (CANADA CORPORATION) 5102-50TH AVENUE, 6TH FLOOR SCOTIA CENTER, YELLOWKNIFE, CANADA, X1A 2L9, SN 75-980,418. FILED 9-30-1999. PRINCIPAL REGISTER.

2,827,360. REG. 3-30-2004. SUSHI SIGLO XXI, S.L. (SPAIN CORPORATION) MIGUEL DE CERVANTES, 46, 07730 ALAIOR (MENORCA) ISLAS BALEARES, SPAIN., SN 76-488,238. FILED 2-4-2003. PRINCIPAL REGISTER.

## DOROTEA

OWNER OF SPAIN REG. NO. 1.999.605, DATED 2-20-1997. THE TERM "DOROTEA" IS A COMMON NAME FOR WOMEN, EQUIVALENT TO "DOROTHY".  
INT. CL. 25/U.S. CLS. 22 AND 39

FOR [ ALL TYPES OF CLOTHING FOR MEN, WOMEN AND CHILDREN, NAMELY, SHIRTS, T-SHIRTS, TROUSERS, SHORTS, SKIRTS, PULLOVERS, SWEATERS, CARDIGANS, JACKETS, SWIMWEAR, COATS, ANORAKS, BELTS, TIES, WRISTBANDS, SOCKS; HEADGEAR, NAMELY, HATS, CAPS, HEADBANDS; ] FOOTWEAR, NAMELY, SHOES, BOOTS, SLIPPERS, SANDALS AND SPORT SHOES.

FIRST USE ; IN COMMERCE .

ELEMENTS AMENDED  
GOODS/SERVICES

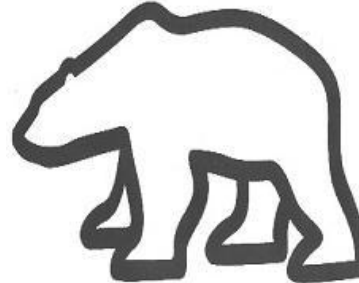

PRIORITY CLAIMED UNDER SEC. 44(D) ON CANADA APPLICATION NO. 1010635, FILED 3-31-1999.  
INT. CL. 14/U.S. CLS. 2, 27, 28 AND 50  
FOR LOOSE AND SET DIAMONDS.  
FIRST USE 5-0-1999; IN COMMERCE 5-0-1999.

ELEMENTS AMENDED  
MARK

2,918,420. REG. 1-18-2005. ECOTRUST (OREGON NON-PROFIT PUBLIC BENEFIT CORPORATION) 721 NW 9TH AVENUE, SUITE 200, PORTLAND, OR. 97209, SN 76-483,586. FILED 1-21-2003. PRINCIPAL REGISTER.

## SALMON NATION

2,875,003. REG. 8-17-2004. GLOBAL ASSOCIATION OF RISK PROFESSIONALS, INC. (NEW JERSEY NON-PROFIT CORPORATION) 111 TOWN SQUARE PLACE, SUITE 1215, JERSEY CITY, NJ, 07310, SN 78-297,530. FILED 9-8-2003. PRINCIPAL REGISTER.



OWNER OF U.S. REG. NOS. 2,212,446 AND 2,470,980. NO CLAIM IS MADE TO THE EXCLUSIVE RIGHT TO USE "GLOBAL ASSOCIATION OF RISK PROFESSIONALS", APART FROM THE MARK AS SHOWN.  
INT. CL. 35/U.S. CLS. 100, 101 AND 102

FOR ASSOCIATION SERVICES, NAMELY, PROMOTING THE INTERESTS OF RISK MANAGEMENT PROFESSIONALS.

FIRST USE 8-0-2002; IN COMMERCE 8-0-2002.

ELEMENTS CORRECTED  
OWNER NAME  
OWNER ADDRESS  
CITIZENSHIP

NO CLAIM IS MADE TO THE EXCLUSIVE RIGHT TO USE SALMON, APART FROM THE MARK AS SHOWN.  
INT. CL. 16/U.S. CLS. 2, 5, 22, 23, 29, 37, 38 AND 50

FOR STICKERS, POSTERS, MAGAZINES [ PAMPHLETS ] AND BOOKS CONCERNING ENVIRONMENTALLY SUSTAINABLE LIFESTYLES, ACTIVITIES, EVENTS, BUSINESS PRACTICES AND ATTRACTIONS.

FIRST USE 12-31-1999; IN COMMERCE 12-31-1999.

INT. CL. 25/U.S. CLS. 22 AND 39

FOR HATS AND CLOTHING, NAMELY SHIRTS PROMOTING ENVIRONMENTALLY SUSTAINABLE LIFESTYLES, ACTIVITIES, EVENTS, BUSINESS PRACTICES AND ATTRACTIONS.

FIRST USE 6-13-2002; IN COMMERCE 9-9-2002.

INT. CL. 26/U.S. CLS. 37, 39, 40, 42 AND 50

FOR ORNAMENTAL NOVELTY PINS [ AND ORNAMENTAL NOVELTY BUTTONS ] PROMOTING ENVIRONMENTALLY SUSTAINABLE LIFESTYLES, ACTIVITIES, EVENTS, BUSINESS PRACTICES AND ATTRACTIONS.

FIRST USE 5-31-2002; IN COMMERCE 10-7-2002.

INT. CL. 35/U.S. CLS. 100, 101 AND 102

FOR [ ON-LINE RETAIL STORE SERVICES FEATURING PINS, POSTERS, MAGAZINES, BOOKS AND CLOTHING PROMOTING ENVIRONMENTALLY SUSTAINABLE LIFESTYLES, ACTIVITIES, EVENTS, BUSINESS PRACTICES AND ATTRACTIONS; CONSULTING SERVICES AND PROVIDING ON-LINE COMPUTER DATABASES IN THE FIELD OF ENVIRONMENTALLY SUSTAINABLE BUSINESS PRACTICES ].

FIRST USE 9-15-2002; IN COMMERCE 9-16-2002.

INT. CL. 41/U.S. CLS. 100, 101 AND 107

FOR [ EDUCATIONAL SERVICES, NAMELY, CONDUCTING CLASSES, SEMINARS, CONFERENCES AND WORKSHOPS IN THE FIELD OF ENVIRONMENTALLY SUSTAINABLE LIFESTYLES, ACTIVITIES, EVENTS, BUSINESS PRACTICES AND ATTRACTIONS ].

FIRST USE 5-31-2002; IN COMMERCE 5-31-2002.

INT. CL. 45/U.S. CLS. 100 AND 101

FOR [ CONSULTING SERVICES AND ] PROVIDING ON-LINE COMPUTER DATABASES IN THE FIELD OF ENVIRONMENTALLY SUSTAINABLE LIFESTYLES.  
FIRST USE 11-30-2002; IN COMMERCE 11-30-2002.

ELEMENTS CORRECTED  
OWNER NAME

---

2,920,943. REG. 1-25-2005. KANGRA GROUP (PROPRIETARY) LIMITED (SOUTH AFRICA CORPORATION) 1 ALBANY ROAD, PARKTOWN, JOHANNESBURG, SOUTH AFRICA., SN 78-366,965. FILED 2-12-2004. PRINCIPAL REGISTER.

## RAILROAD RED

THE MARK CONSISTS OF STANDARD CHARACTERS WITHOUT CLAIM TO ANY PARTICULAR FONT, STYLE, SIZE, OR COLOR.

OWNER OF SOUTH AFRICA REG. NO. 933971, DATED 5-17-1993, EXPIRES 5-17-2013.

NO CLAIM IS MADE TO THE EXCLUSIVE RIGHT TO USE "RED", APART FROM THE MARK AS SHOWN.

INT. CL. 33/U.S. CLS. 47 AND 49  
FOR WINES.

ELEMENTS CORRECTED  
OWNER NAME

---

2,948,289. REG. 5-10-2005. ENOVA SYSTEMS, INC. (CALIFORNIA CORPORATION) 1560 WEST 190TH ST., TORRANCE, CA, 90501, SN 75-983,531. FILED 1-28-2000. PRINCIPAL REGISTER.

## ENOVA

THE MARK CONSISTS OF STANDARD CHARACTERS WITHOUT CLAIM TO ANY PARTICULAR FONT, STYLE, SIZE, OR COLOR.

INT. CL. 9/U.S. CLS. 21, 23, 26, 36 AND 38

FOR ELECTRONIC SYSTEMS FOR USE IN LAND VEHICLES, NAMELY ELECTRIC AND HYBRID VEHICLE DRIVE TRAIN SYSTEMS COMPOSED OF INTERNAL COMBUSTION ENGINES, GENERATORS, ELECTRIC MOTORS, POWER CONTROLLERS, INVERTERS, COMPUTER SOFTWARE AND COMPUTER FIRMWARE; ELECTRONIC SYSTEMS FOR USE IN LAND VEHICLES, NAMELY ENERGY MANAGEMENT SYSTEMS COMPOSED OF AN ELECTRIC CONTROLLER, BATTERIES, CHARGERS, COMPUTER SOFTWARE AND COMPUTER FIRMWARE; ELECTRICAL CONTROLLERS, ELECTRIC CONVERTERS, BATTERY CHARGERS, INVERTERS, AND ACCOMPANYING COMPUTER SOFTWARE FOR USE IN THE OPERATION AND CONTROL OF ELECTRIC AND HYBRID VEHICLE DRIVE TRAIN SYSTEMS, ENERGY MANAGEMENT SYSTEMS, ENERGY STORAGE SYSTEMS, AND THE COMPONENTS OF THE SYSTEMS.

FIRST USE 11-17-1999; IN COMMERCE 6-15-2000.  
INT. CL. 12/U.S. CLS. 19, 21, 23, 31, 35 AND 44

FOR ELECTRIC MOTORS FOR LAND VEHICLES; ELECTRO-HYDRAULIC ASSIST POWER STEERING SYSTEMS COMPOSED OF AN ELECTRIC MOTOR, PUMP AND CONTROLLER FOR LAND VEHICLES; TRANSMISSION GEARS AND GEAR REDUCTION UNITS FOR LAND VEHICLES.

FIRST USE 11-17-1999; IN COMMERCE 6-15-2000.  
INT. CL. 40/U.S. CLS. 100, 103 AND 106

FOR MANUFACTURE TO THE ORDER AND/OR TO THE SPECIFICATIONS OF OTHERS OF ELECTRIC AND HYBRID DRIVE TRAIN AND ENERGY MANAGEMENT AND STORAGE SYSTEMS AND COMPONENTS FOR USE IN LAND VEHICLES.

FIRST USE 11-17-1999; IN COMMERCE 1-25-2000.  
INT. CL. 42/U.S. CLS. 100 AND 101

FOR RESEARCH AND DEVELOPMENT OF NEW PRODUCTS FOR OTHERS, DESIGN AND TESTING OF NEW PRODUCTS FOR OTHERS, AND COMPUTER SOFTWARE CONSULTATION SERVICES AND COMPUTER SOFTWARE DESIGN FOR OTHERS, ALL IN THE FIELD OF ELECTRIC AND HYBRID DRIVE SYSTEMS FOR VEHICULAR APPLICATIONS, AND BATTERY AND FUEL CELL TECHNOLOGIES.

FIRST USE 11-17-1999; IN COMMERCE 1-25-2000.

ELEMENTS AMENDED  
OWNER ADDRESS  
MARK  
[DISCLAIMER]

---

2,948,945. REG. 5-10-2005. YOUTHFRONT, INC. (KANSAS CORPORATION) 4715 RAINBOW BOULEVARD, SHAWNEE MISSION, KS, 66205, SN 76-447,727. FILED 9-9-2002. PRINCIPAL REGISTER.

## YOUTHFRONT

THE MARK CONSISTS OF STANDARD CHARACTERS WITHOUT CLAIM TO ANY PARTICULAR FONT, STYLE, SIZE, OR COLOR.

OWNER OF U.S. REG. NOS. 2,327,341 AND 2,499,106.

NO CLAIM IS MADE TO THE EXCLUSIVE RIGHT TO USE "YOUTH", APART FROM THE MARK AS SHOWN.

INT. CL. 35/U.S. CLS. 100, 101 AND 102

FOR BUSINESS MANAGEMENT CONSULTATION IN THE FIELD OF FUND RAISING FOR YOUTH MINISTRY PROGRAMS.

FIRST USE 2-12-2001; IN COMMERCE 2-12-2001.

INT. CL. 41/U.S. CLS. 100, 101 AND 107

FOR TRAINING SERVICES IN THE FIELD OF YOUTH MINISTRIES.

FIRST USE 10-10-2002; IN COMMERCE 10-10-2002.

ELEMENTS AMENDED  
MARK

---

2,950,028. REG. 5-10-2005. ROLEX WATCH U.S.A., INC. (NEW YORK CORPORATION) 665 FIFTH AVENUE, NEW YORK, NY, 10022, SN 78-252,196. FILED 5-20-2003. PRINCIPAL REGISTER.

## TURN-O-GRAPH

INT. CL. 14/U.S. CLS. 2, 27, 28 AND 50  
FOR WATCHES AND PARTS THEREOF.  
FIRST USE 9-15-2004; IN COMMERCE 9-15-2004.

ELEMENTS CORRECTED  
CITIZENSHIP

2,953,542. REG. 5-17-2005. ROLEX WATCH U.S.A., INC. (NEW YORK CORPORATION) 665 FIFTH AVENUE, NEW YORK, NY, 10022, SN 78-281,940. FILED 8-1-2003. PRINCIPAL REGISTER.

3,044,659. REG. 1-17-2006. AMBERSON HOLDINGS LLC (DELAWARE LIMITED LIABILITY COMPANY) SUITE 1104, 121 WEST 27TH ST, NEW YORK, NY, 10001, SN 78-397,402. FILED 4-6-2004. PRINCIPAL REGISTER.

## AIR-KING

INT. CL. 14/U.S. CLS. 2, 27, 28 AND 50  
FOR WATCHES AND PARTS THEREOF.  
FIRST USE 12-31-1962; IN COMMERCE 12-31-1962.

ELEMENTS CORRECTED  
CITIZENSHIP

2,958,172. REG. 5-31-2005. SUN DENSHI KABUSHIKI KAISHA (JAPAN CORPORATION), TA SUNCORPORATION, 250 ASAHI, KOCHINO-CHO, KONAN, AICHI 483-8555, JAPAN., SN 78-264,013. FILED 6-18-2003. PRINCIPAL REGISTER.

## ALBERT ODYSSEY

THE NAME SHOWN IN THE MARK DOES NOT IDENTIFY A PARTICULAR LIVING INDIVIDUAL.

INT. CL. 9/U.S. CLS. 21, 23, 26, 36 AND 38  
FOR VIDEO GAME DISCS, COMPUTER GAME PROGRAMS, AND COMPUTER GAME DISCS ON CD-ROM.  
FIRST USE 3-5-1993; IN COMMERCE 3-5-1993.

ELEMENTS CORRECTED  
DBA/AKA

3,029,369. REG. 12-13-2005. SANOFI-AVENTIS (FRANCE CORPORATION) 174, AVENUE DE FRANCE, F-75013 PARIS, FRANCE., SN 79-004,363. FILED 6-4-2004. PRINCIPAL REGISTER.

# SYVITAL

THE MARK CONSISTS OF STANDARD CHARACTERS WITHOUT CLAIM TO ANY PARTICULAR FONT, STYLE, SIZE, OR COLOR.

PRIORITY DATE OF 12-30-2003 IS CLAIMED.  
OWNER OF INTERNATIONAL REGISTRATION 0830543 DATED 6-4-2004, EXPIRES 6-4-2014.

INT. CL. 5/U.S. CLS. 6, 18, 44, 46, 51 AND 52  
FOR PHARMACEUTICAL PREPARATIONS FOR SMOKING CESSATION, FOR THE PREVENTION OF CARDIOVASCULAR DISEASES AND FOR THE TREATMENT OF OBESITY: \* EXCLUDING HOMEOPATHIC PREPARATIONS AND PREPARATIONS FOR THE TREATMENT OF PSYCHOSOMATIC DISORDERS \*.  
FIRST USE ; IN COMMERCE .

ELEMENTS CORRECTED  
GOODS/SERVICES

## LEONARD BERNSTEIN

THE MARK CONSISTS OF STANDARD CHARACTERS WITHOUT CLAIM TO ANY PARTICULAR FONT, STYLE, SIZE, OR COLOR.

OWNER OF U.S. REG. NOS. 1,244,832, 1,714,285 AND OTHERS.  
SEC. 2(F).

INT. CL. 35/U.S. CLS. 100, 101 AND 102  
FOR ONLINE RETAIL STORE SERVICES FEATURING CLOTHING, PRINTED MATTER, AUDIO AND VIDEO CASSETTES, COMPACT DISCS, DIGITAL VIDEO DISCS, GLASSWARE, PAPER GOODS, ART WORK, TOTE BAGS [ ; LICENSING OF MUSICAL AND THEATRICAL PERFORMANCES ].

FIRST USE 11-0-2000; IN COMMERCE 11-0-2000.  
INT. CL. 38/U.S. CLS. 100, 101 AND 104

FOR PROVIDING ONLINE ELECTRONIC BULLETIN BOARDS FOR TRANSMISSION OF MESSAGES AMONG COMPUTER USERS CONCERNING MUSICAL PERFORMANCES, MUSICAL COMPOSITIONS, SOFTWARE OF INTEREST TO MUSICIANS, AND ARTICLES AND EDITORIALS ON THE SUBJECT OF MUSIC.

FIRST USE 11-0-1996; IN COMMERCE 11-0-1996.  
INT. CL. 41/U.S. CLS. 100, 101 AND 107

FOR ON-LINE LIBRARY SERVICES, NAMELY, PROVIDING ELECTRONIC LIBRARY SERVICES WHICH FEATURE DISCOGRAPHIES AND COMPOSER WRITING LIBRARIES VIA AN ON-LINE COMPUTER NETWORK.

FIRST USE 11-0-2000; IN COMMERCE 11-0-2000.  
INT. CL. 45/U.S. CLS. 100 AND 101

FOR LICENSING OF TRADEMARKS; LICENSING OF MUSICAL AND THEATRICAL PERFORMANCES.  
FIRST USE 11-0-2000; IN COMMERCE 11-0-2000.

ELEMENTS AMENDED  
GOODS/SERVICES  
INTERNATIONAL CLASS(ES)  
DATE OF FIRST USE  
DATE OF FIRST USE IN COMMERCE

3,123,869. REG. 8-1-2006. JUNGPFANZEN GRÜNEWALD GMBH (FED REP GERMANY LIMITED LIABILITY COMPANY) KOCHSTR. 6, 59379 SELM, FED REP GERMANY., SN 79-014,751. FILED 7-4-2005. PRINCIPAL REGISTER.

# Colour Bells

THE MARK CONSISTS OF STANDARD CHARACTERS WITHOUT CLAIM TO ANY PARTICULAR FONT, STYLE, SIZE, OR COLOR.

PRIORITY DATE OF 1-5-2005 IS CLAIMED.  
OWNER OF INTERNATIONAL REGISTRATION 0859658 DATED 7-4-2005, EXPIRES 7-4-2015.  
INT. CL. 31/U.S. CLS. 1 AND 46

FOR [ AGRICULTURAL, HORTICULTURAL AND FORESTRY PRODUCTS NOT INCLUDED IN OTHER CLASSES, NAMELY, SEEDS AND BULBS FOR AGRICULTURAL PURPOSES, AGRICULTURAL SEEDS, SPORES AND SPAWN FOR AGRICULTURAL PURPOSES, AGRICULTURAL GRAINS FOR PLANTING, SEEDS AND BULBS FOR HORTICULTURAL PURPOSES, LIVING TREES, NON-DEBARKED TIMBER, UNSAWN TIMBER, RAW TIMBER, UNPROCESSED TIMBER; GRAINS, NAMELY, UNPROCESSED GRAINS, AGRICULTURAL AND HORTICULTURAL GRAINS FOR PLANTING; ] NATURAL PLANTS AND FLOWERS, NAMELY, LIVE FLOWERING PLANTS, LIVING PLANTS, [ LIVING FRUIT PLANTS, ] LIVE FLOWERS.  
FIRST USE ; IN COMMERCE .

ELEMENTS CORRECTED  
GOODS/SERVICES

3,127,092. REG. 8-8-2006. JUNGPFANZEN GRÜNEWALD GMBH (FED REP GERMANY GMBH) KOCHSTR. 6, 59379 SELM, FED REP GERMANY., SN 79-009,920. FILED 2-14-2005. PRINCIPAL REGISTER.

# €uro Innovate

PRIORITY DATE OF 8-16-2004 IS CLAIMED.  
OWNER OF INTERNATIONAL REGISTRATION 0846426  
DATED 2-14-2005, EXPIRES 2-14-2015.  
INT. CL. 31/U.S. CLS. 1 AND 46

FOR [ AGRICULTURAL, HORTICULTURAL AND FORESTRY PRODUCTS NOT INCLUDED IN OTHER CLASSES, NAMELY, SEEDS AND BULBS FOR AGRICULTURAL PURPOSES, AGRICULTURAL SEEDS, SPORES AND SPAWN FOR AGRICULTURAL PURPOSES, AGRICULTURAL GRAINS FOR PLANTING, SEEDS AND BULBS FOR HORTICULTURAL PURPOSES, LIVING TREES, NON-DEBARKED TIMBER, UNSAWN TIMBER, RAW TIMBER, UNPROCESSED TIMBER; GRAINS, NAMELY, UNPROCESSED GRAINS, AGRICULTURAL AND HORTICULTURAL GRAINS FOR PLANTING; FRESH FRUITS AND VEGETABLES; AGRICULTURAL AND HORTICULTURAL SEEDS, NAMELY, CROP SEEDS, GRASS SEEDS, PLANT SEEDS; ] NATURAL PLANTS AND FLOWERS, NAMELY, LIVE FLOWERING PLANTS, LIVING PLANTS, [ LIVING FRUIT PLANTS, ] LIVE FLOWERS.  
FIRST USE ; IN COMMERCE .

ELEMENTS CORRECTED  
GOODS/SERVICES

3,133,242. REG. 8-22-2006. JUNGPFANZEN GRÜNEWALD GMBH (FED REP GERMANY GMBH) KOCHSTR. 6, 59379 SELM, FED REP GERMANY., SN 79-009,532. FILED 2-14-2005. PRINCIPAL REGISTER.



PRIORITY DATE OF 8-16-2004 IS CLAIMED.  
OWNER OF INTERNATIONAL REGISTRATION 0845326  
DATED 2-14-2005, EXPIRES 2-14-2015.

THE COLOR(S) BLACK, WHITE, GRAY, RED, PALE PINK, DARK PINK, AND BLUE ARE CLAIMED AS A FEATURE OF THE MARK.

THE COLOR RED APPEARS IN MOST OF NORTH AMERICA, CENTRAL AMERICA, NEW ZEALAND, AUSTRALIA, AND INDONESIA IN THE MARK. THE COLOR BLACK APPEARS SCATTERED THROUGHOUT THE MARK AS WELL AS IN THE OUTLINE OF THE MARK. THE COLOR GRAY ALSO APPEARS SCATTERED THROUGHOUT THE MARK. THE COLOR PALE PINK APPEARS IN THE MAJORITY OF SOUTH AMERICA IN THE MARK. THE COLOR YELLOW APPEARS AS TWO SMALL SPOTS IN SOUTH AMERICA AND IN THE MAJORITY OF AFRICA IN THE MARK. THE COLOR BLUE APPEARS IN MOST OF EUROPE AND THE MIDDLE EAST IN THE MARK. THE COLOR WHITE IS IN THE BACKGROUND OF THE MARK. THE COLOR DARK PINK APPEARS IN ASIA IN THE MARK AND IN THE SMALL CIRCULAR SHAPE IN THE PERSIAN GULF.  
INT. CL. 31/U.S. CLS. 1 AND 46

FOR [ AGRICULTURAL, HORTICULTURAL AND FORESTRY PRODUCTS NOT INCLUDED IN OTHER CLASSES, NAMELY, SEEDS AND BULBS FOR AGRICULTURAL PURPOSES, AGRICULTURAL SEEDS, SPORES AND SPAWN FOR AGRICULTURAL PURPOSES, AGRICULTURAL GRAINS FOR PLANTING, SEEDS AND BULBS FOR HORTICULTURAL PURPOSES, LIVING TREES, NON-DEBARKED TIMBER, UNSAWN TIMBER, RAW TIMBER, UNPROCESSED TIMBER; GRAINS, NAMELY, UNPROCESSED GRAINS, AGRICULTURAL AND HORTICULTURAL GRAINS FOR PLANTING; FRESH FRUITS AND VEGETABLES; AGRICULTURAL AND HORTICULTURAL SEEDS, NAMELY, CROP SEEDS, GRASS SEEDS, PLANT SEEDS; ] NATURAL PLANTS AND FLOWERS, NAMELY, LIVE FLOWERING PLANTS, LIVING PLANTS, [ LIVING FRUIT PLANTS, ] LIVE FLOWERS.  
FIRST USE ; IN COMMERCE .

ELEMENTS CORRECTED  
GOODS/SERVICES

3,142,413. REG. 9-12-2006. JUNGPFANZEN GRÜNEWALD GMBH (FED REP GERMANY LIMITED COMPANY) KOCHSTRABE 6, 59379 SELM, FED REP GERMANY., SN 79-016,472. FILED 7-12-2005. PRINCIPAL REGISTER.

# Tiny Pleasure

THE MARK CONSISTS OF STANDARD CHARACTERS WITHOUT CLAIM TO ANY PARTICULAR FONT, STYLE, SIZE, OR COLOR.

PRIORITY DATE OF 1-13-2005 IS CLAIMED.  
OWNER OF INTERNATIONAL REGISTRATION 0865535  
DATED 7-12-2005, EXPIRES 7-12-2015.  
INT. CL. 31/U.S. CLS. 1 AND 46

FOR [ AGRICULTURAL, HORTICULTURAL AND FORESTRY PRODUCTS NOT INCLUDED IN OTHER CLASSES, NAMELY, SEEDS AND BULBS FOR AGRICULTURAL PURPOSES, AGRICULTURAL SEEDS, SPORES AND SPAWN FOR AGRICULTURAL PURPOSES, AGRICULTURAL GRAINS FOR PLANTING, SEEDS AND BULBS FOR HORTICULTURAL PURPOSES, LIVING TREES, NON-DEBARKED TIMBER, UNSAWN TIMBER, RAW TIMBER, UNPROCESSED TIMBER; GRAINS, NAMELY, UNPROCESSED GRAINS, AGRICULTURAL AND HORTICULTURAL GRAINS FOR PLANTING; ] NATURAL PLANTS AND FLOWERS, NAMELY, LIVE FLOWERING PLANTS, LIVING PLANTS, [ LIVING FRUIT PLANTS, ] LIVE FLOWERS [; MALT FOR BREWING AND DISTILLING ].  
FIRST USE ; IN COMMERCE .

ELEMENTS CORRECTED  
GOODS/SERVICES

3,194,719. REG. 1-2-2007. JUNGPFANZEN GRÜNEWALD GMBH (FED REP GERMANY LIMITED COMPANY (GERMAN GMBH)) KOCHSTRABE 6, 59379 SELM, FED REP GERMANY., SN 79-025,001. FILED 3-7-2006. PRINCIPAL REGISTER.

3,204,226. REG. 1-30-2007. JUNGPFANZEN GRÜNEWALD GMBH (FED REP GERMANY LIMITED COMPANY (GERMAN GMBH)) KOCHSTRABE 6, 59379 SELM, FED REP GERMANY., SN 79-024,636. FILED 3-7-2006. PRINCIPAL REGISTER.

# Dazzling Lips



THE MARK CONSISTS OF STANDARD CHARACTERS WITHOUT CLAIM TO ANY PARTICULAR FONT, STYLE, SIZE, OR COLOR.

PRIORITY DATE OF 9-12-2005 IS CLAIMED.  
OWNER OF INTERNATIONAL REGISTRATION 0887934 DATED 3-7-2006, EXPIRES 3-7-2016.  
INT. CL. 31/U.S. CLS. 1 AND 46

FOR [ AGRICULTURAL, HORTICULTURAL AND FORESTRY PRODUCTS NOT INCLUDED IN OTHER CLASSES, NAMELY, SEEDS AND BULBS FOR AGRICULTURAL PURPOSES, AGRICULTURAL SEEDS, SPORES AND SPAWN FOR AGRICULTURAL PURPOSES, AGRICULTURAL GRAINS FOR PLANTING, SEEDS AND BULBS FOR HORTICULTURAL PURPOSES, LIVING TREES, NON-DEBARKED TIMBER, UNSAWN TIMBER, RAW TIMBER, UNPROCESSED TIMBER; GRAINS, NAMELY, UNPROCESSED GRAINS, AGRICULTURAL AND HORTICULTURAL GRAINS FOR PLANTING; ] NATURAL PLANTS AND FLOWERS, NAMELY, LIVE FLOWERING PLANTS, LIVING PLANTS, [ LIVING FRUIT PLANTS, ] LIVE FLOWERS.  
FIRST USE ; IN COMMERCE .

ELEMENTS CORRECTED  
GOODS/SERVICES

PRIORITY DATE OF 9-12-2005 IS CLAIMED.  
OWNER OF INTERNATIONAL REGISTRATION 0886943 DATED 3-7-2006, EXPIRES 3-7-2016.

NO CLAIM IS MADE TO THE EXCLUSIVE RIGHT TO USE "MAGNIFICO", APART FROM THE MARK AS SHOWN.

THE COLOR(S) GREEN, PINK, DARK RED, WHITE IS/ ARE CLAIMED AS A FEATURE OF THE MARK.

THE MARK CONSISTS OF THE WORDING MAGNIFICO, WITH THE LETTERS M A G N F I C O IN GREEN. THE FIRST I IN THE WORDING APPEARS IN WHITE. IN THE MIDDLE OF A DARK RED CRESCENT SHAPE FORMING AN INCOMPLETE CIRCLE. A SMALLER, OPPOSITE FACING CRESCENT SHAPE APPEARS IN PINK WITHIN THE LARGER CRESCENT, AND BEHIND THE LETTER A.

THE FOREIGN WORDING IN THE MARK TRANSLATES INTO ENGLISH AS MAGNIFICENT.  
INT. CL. 31/U.S. CLS. 1 AND 46

FOR [ AGRICULTURAL, HORTICULTURAL AND FORESTRY PRODUCTS NOT INCLUDED IN OTHER CLASSES, NAMELY, SEEDS AND BULBS FOR AGRICULTURAL PURPOSES, AGRICULTURAL SEEDS, SPORES AND SPAWN FOR AGRICULTURAL PURPOSES, AGRICULTURAL GRAINS FOR PLANTING, SEEDS AND BULBS FOR HORTICULTURAL PURPOSES, LIVING TREES, NON-DEBARKED TIMBER, UNSAWN TIMBER, RAW TIMBER, UNPROCESSED TIMBER; GRAINS, NAMELY, UNPROCESSED GRAINS, AGRICULTURAL AND HORTICULTURAL GRAINS FOR PLANTING; ] NATURAL PLANTS AND FLOWERS, NAMELY, LIVE FLOWERING PLANTS, LIVING PLANTS, [ LIVING FRUIT PLANTS, ] LIVE FLOWERS.  
FIRST USE ; IN COMMERCE .

ELEMENTS CORRECTED  
GOODS/SERVICES

3,194,720. REG. 1-2-2007. JUNGPFANZEN GRÜNEWALD GMBH (FED REP GERMANY LIMITED COMPANY (GERMAN GMBH)) KOCHSTRABE 6, 59379 SELM, FED REP GERMANY., SN 79-025,003. FILED 3-7-2006. PRINCIPAL REGISTER.

# croftway

THE MARK CONSISTS OF STANDARD CHARACTERS WITHOUT CLAIM TO ANY PARTICULAR FONT, STYLE, SIZE, OR COLOR.

PRIORITY DATE OF 9-12-2005 IS CLAIMED.  
OWNER OF INTERNATIONAL REGISTRATION 0887936 DATED 3-7-2006, EXPIRES 3-7-2016.  
INT. CL. 31/U.S. CLS. 1 AND 46

FOR [ AGRICULTURAL, HORTICULTURAL AND FORESTRY PRODUCTS NOT INCLUDED IN OTHER CLASSES, NAMELY, SEEDS AND BULBS FOR AGRICULTURAL PURPOSES, AGRICULTURAL SEEDS, SPORES AND SPAWN FOR AGRICULTURAL PURPOSES, AGRICULTURAL GRAINS FOR PLANTING, SEEDS AND BULBS FOR HORTICULTURAL PURPOSES, LIVING TREES, NON-DEBARKED TIMBER, UNSAWN TIMBER, RAW TIMBER, UNPROCESSED TIMBER; GRAINS, NAMELY, UNPROCESSED GRAINS, AGRICULTURAL AND HORTICULTURAL GRAINS FOR PLANTING; ] NATURAL PLANTS AND FLOWERS, NAMELY, LIVE FLOWERING PLANTS, LIVING PLANTS, [ LIVING FRUIT PLANTS, ] LIVE FLOWERS.  
FIRST USE ; IN COMMERCE .

ELEMENTS CORRECTED  
GOODS/SERVICES

3,211,682. REG. 2-20-2007. JUNGPFANZEN GRÜNEWALD GMBH (FED REP GERMANY LIMITED COMPANY (GERMAN GMBH)) KOCHSTRABE 6, 59379 SELM, FED REP GERMANY., SN 79-024,635. FILED 3-7-2006. PRINCIPAL REGISTER.



PRIORITY DATE OF 9-12-2005 IS CLAIMED.

OWNER OF INTERNATIONAL REGISTRATION 0886942 DATED 3-7-2006, EXPIRES 3-7-2016.

THE COLOR(S) GREEN, PURPLE, WHITE, BLACK, YELLOW, RED, ORANGE, BROWN, GREY, AND FLESH TONE IS/ARE CLAIMED AS A FEATURE OF THE MARK.

THE MARK CONSISTS OF A MAN WITH A FLESH TONE FACE AND HANDS, BLACK HAIR, AND BLACK OUTLINING HIM AND HIS FACIAL FEATURES, WEARING A WHITE CHEF'S COAT AND WHITE CHEF'S HAT, GREY PANTS AND GREY SHOES WITH BLACK LACES, STANDING IN A KITCHEN, HOLDING PURPLE FLOWERS WITH GREEN STEMS AND LEAVES. THE KITCHEN HAS A WHITE TILE FLOOR WITH THE TILES OUTLINED IN BLACK, ORANGE CUPBOARDS WITH BLACK DETAILING, AND WHITE COUNTERTOPS. IN THE MIDDLE OF THE CUPBOARDS THERE IS A BLACK HOTPLATE IN FRONT OF A GRAY EXTRACTOR HOOD, AND ABOVE A SET OF WHITE DRAWERS WITH BLACK DETAILING. ON THE HOT PLATE IS A GRAY POT WITH GREEN CONTENTS. THREE BOTTLES OF WINE SIT ON THE KITCHEN COUNTERTOP; ONE IS BROWN WITH A GREEN LABEL, ONE GREEN WITH A RED LABEL, AND ONE BROWN WITH A RED LABEL. TWO ORANGE FLOWERPOTS WITH GREEN LEAVES AND PURPLE FLOWERS SIT ON THE KITCHEN FLOOR IN FRONT OF THE CHEF. A WHITE LIGHT OUTLINED IN BLACK HANGS FROM THE CEILING. THE LEFT HAND SIDE HAS A YELLOW BACKGROUND WALL; THE REST OF THE BACKGROUND IS A SET OF WINDOWS WITH A WHITE BACKGROUND, OUTLINED IN BLACK, WITH A GRAY COLUMN SEPARATING THEM. A GREEN TREE CAN BE SEEN THROUGH THE WINDOW ON THE RIGHT HAND SIDE. ALL FEATURES AND FORMS IN THE DRAWING ARE OUTLINED IN BLACK.

INT. CL. 31/U.S. CLS. 1 AND 46

FOR [ AGRICULTURAL, HORTICULTURAL AND FORESTRY PRODUCTS NOT INCLUDED IN OTHER CLASSES, NAMELY, SEEDS AND BULBS FOR AGRICULTURAL PURPOSES, AGRICULTURAL SEEDS, SPORES AND SPAWN FOR AGRICULTURAL PURPOSES, AGRICULTURAL GRAINS FOR PLANTING, SEEDS AND BULBS FOR HORTICULTURAL PURPOSES, LIVING TREES, NON-DEBARKED TIMBER, UNSAWN TIMBER, RAW TIMBER, UNPROCESSED TIMBER; GRAINS, NAMELY, UNPROCESSED GRAINS, AGRICULTURAL AND HORTICULTURAL GRAINS FOR PLANTING; ] NATURAL PLANTS AND FLOWERS, NAMELY, LIVE FLOWERING PLANTS, LIVING PLANTS, [ LIVING FRUIT PLANTS, ] LIVE FLOWERS.

FIRST USE ; IN COMMERCE .

ELEMENTS CORRECTED  
GOODS/SERVICES

3,211,690. REG. 2-20-2007. JUNGPFANZEN GRÜNEWALD GMBH (FED REP GERMANY LIMITED COMPANY (GERMAN GMBH)) KOCHSTRABE 6, 59379 SELM, FED REP GERMANY., SN 79-027,149. FILED 3-7-2006. PRINCIPAL REGISTER.



PRIORITY DATE OF 9-12-2005 IS CLAIMED.  
OWNER OF INTERNATIONAL REGISTRATION 0894011 DATED 3-7-2006, EXPIRES 3-7-2016.

THE COLOR(S) RED, BLUE, LIGHT GREEN, DARK GREEN, BLACK AND WHITE IS/ARE CLAIMED AS A FEATURE OF THE MARK.

BLACK AS COLOR OF THE LETTERS "SUMMER ISLAND". RED AS THE UPPER PART OF THE FEATHER SHAPED GRAPHIC. BLUE AS THE LOWER PART OF THE FEATHER SHAPED GRAPHIC. WHITE AS THE PIN-FEATHER OF THE FEATHER SHAPED GRAPHIC. LIGHT AND DARK GREEN, RED AND WHITE AS PART OF THE GRAPHIC UNDERNEATH THE WORD "SUMMER ISLAND".

INT. CL. 31/U.S. CLS. 1 AND 46

FOR [ AGRICULTURAL, HORTICULTURAL AND FORESTRY PRODUCTS NOT INCLUDED IN OTHER CLASSES, NAMELY, SEEDS AND BULBS FOR AGRICULTURAL PURPOSES, AGRICULTURAL SEEDS, SPORES AND SPAWN FOR AGRICULTURAL PURPOSES, AGRICULTURAL GRAINS FOR PLANTING, SEEDS AND BULBS FOR HORTICULTURAL PURPOSES, LIVING TREES, NON-DEBARKED TIMBER, UNSAWN TIMBER, RAW TIMBER, UNPROCESSED TIMBER; GRAINS, NAMELY, UNPROCESSED GRAINS, AGRICULTURAL AND HORTICULTURAL GRAINS FOR PLANTING; ] NATURAL PLANTS AND FLOWERS, NAMELY, LIVE FLOWERING PLANTS, LIVING PLANTS, [ LIVING FRUIT PLANTS, ] LIVE FLOWERS.

FIRST USE ; IN COMMERCE .

ELEMENTS CORRECTED  
GOODS/SERVICES

3,213,610. REG. 2-27-2007. ATOS WORLDLINE, SOCIÉTÉ ANONYME (BELGIUM SOCIÉTÉ ANONYME (JOINT STOCK COMPANY)) CHAUSSEE DE HAECHE 1442, B-1130 BRUXELLES, BELGIUM., SN 79-015,941. FILED 9-12-2005. PRINCIPAL REGISTER.

# XENTEO

THE MARK CONSISTS OF STANDARD CHARACTERS WITHOUT CLAIM TO ANY PARTICULAR FONT, STYLE, SIZE, OR COLOR.

PRIORITY DATE OF 6-2-2005 IS CLAIMED.

OWNER OF INTERNATIONAL REGISTRATION 0863851 DATED 9-12-2005, EXPIRES 9-12-2015.

OWNER OF U.S. REG. NOS. 3,035,915 AND 3,071,180.

INT. CL. 9/U.S. CLS. 21, 23, 26, 36 AND 38

FOR COMPUTERS, COMPUTER PERIPHERAL UNITS, COMPONENTS, PARTS AND EQUIPMENT FOR DATA PROCESSING AND FOR ELECTRONIC TRANSFER OF FUNDS, NAMELY, PAYMENT TERMINALS AND FULL-RANGE OF TERMINAL BASED APPLICATIONS FROM CARD-READING TO CHIP PROGRAMMING ALLOWING THE USE OF ELECTRONIC PURSE, LOYALTY PROGRAMS, SMART VOUCHERS, ACCESS CONTROL AND CUSTOM APPLICATIONS; [ COMPUTER SOFTWARE FOR USE IN ELECTRONIC TRANSFER OF FUNDS AND DATABASE MANAGEMENT IN THE FIELD OF FINANCE AND BUSINESS MANAGEMENT; ] MAGNETIC STRIP AND CHIP CARDS; \* ALL THESE GOODS IN CONNECTION WITH ELECTRONIC TRANSFER BY DIRECT TRANSFER AND PAYMENT TERMINALS \*.

FIRST USE ; IN COMMERCE .

INT. CL. 36/U.S. CLS. 100, 101 AND 102

FOR FINANCIAL MANAGEMENT SERVICES AND ELECTRONIC TRANSFER OF FUNDS.

INT. CL. 37/U.S. CLS. 100, 103 AND 106

FOR INSTALLATION, MAINTENANCE AND REPAIR SERVICES FOR DATA PROCESSING EQUIPMENT, COMPUTERS AND THEIR PERIPHERAL DEVICES AND FOR EQUIPMENT FOR ELECTRONIC FUNDS TRANSFER.

INT. CL. 38/U.S. CLS. 100, 101 AND 104

FOR TELECOMMUNICATIONS, NAMELY, PROVIDING COMMUNICATION INTERFACES, NAMELY, ISDN SERVICES, PROVIDING FIBER OPTIC NETWORK SERVICES, PROVIDING ACCESS TO A NETWORK OPERATIONS CENTER, COMMUNICATION BY COMPUTER TERMINALS.

INT. CL. 42/U.S. CLS. 100 AND 101

FOR RENTAL OF COMPUTERS AND OTHER SIMILAR COMPUTER EQUIPMENT FOR ELECTRONIC TRANSFER OF FUNDS; COMPUTER PROGRAMMING FOR OTHERS; DESIGN AND UPDATING OF SOFTWARE FOR OTHERS; TECHNICAL CONSULTING CONCERNING COMPUTING; LEASING OF TERMINALS FOR ELECTRONIC TRANSFER OF FUNDS; \* ALL THESE SERVICES IN CONNECTION WITH ELECTRONIC TRANSFER BY DIRECT TRANSFER AND PAYMENT TERMINALS \*.  
FIRST USE ; IN COMMERCE .

ELEMENTS CORRECTED  
\*CITIZENSHIP\*  
\*ENTITY\*  
GOODS/SERVICES

3,218,331. REG. 3-13-2007. JUNGPFANZEN GRÜNEWALD GMBH (FED REP GERMANY LIMITED COMPANY (GERMAN GMBH)) KOCHSTRASSE 6, 59379 SELM, FED REP GERMANY., SN 79-027,148. FILED 3-7-2006. PRINCIPAL REGISTER.



PRIORITY DATE OF 9-12-2005 IS CLAIMED.  
OWNER OF INTERNATIONAL REGISTRATION 0894010 DATED 3-7-2006, EXPIRES 3-7-2016.  
THE COLOR(S) RED, YELLOW, ORANGE, GREEN, BLUE, LILAC, BLACK AND WHITE IS/ARE CLAIMED AS A FEATURE OF THE MARK.

THE MARK CONSISTS OF THE WORD "APADANA" PRINTED IN FRONT OF A RAINBOW IN WHICH A DRAWING OF MEDIAEVAL TOWERS CAN BE SEEN. THE COLORS RED, YELLOW, ORANGE, GREEN, BLUE AND LILAC APPEAR IN THE RAINBOW; BLACK APPEARS IN THE WORDING "APADANA" AND IN THE OUTLINE OF THE TOWERS, AND THE COLOR WHITE APPEARS IN THE BACKGROUND.

INT. CL. 31/U.S. CLS. 1 AND 46

FOR [ AGRICULTURAL, HORTICULTURAL AND FORESTRY PRODUCTS, NAMELY, SEEDS AND BULBS FOR AGRICULTURAL PURPOSES, AGRICULTURAL SEEDS, SPORES AND SPAWN FOR AGRICULTURAL PURPOSES, AGRICULTURAL GRAINS FOR PLANTING, SEEDS AND BULBS FOR HORTICULTURAL PURPOSES, LIVING TREES, NON-DEBARKED TIMBER, UNSAWN TIMBER, RAW TIMBER, UNPROCESSED TIMBER; GRAINS, NAMELY, UNPROCESSED GRAINS, AGRICULTURAL AND HORTICULTURAL GRAINS FOR PLANTING; ] NATURAL PLANTS AND FLOWERS, NAMELY, LIVE FLOWERING PLANTS, LIVING PLANTS, [ LIVING FRUIT PLANTS, ] LIVE FLOWERS.  
FIRST USE ; IN COMMERCE .

ELEMENTS CORRECTED  
GOODS/SERVICES

3,247,809. REG. 5-29-2007. JUNGPFANZEN GRÜNEWALD GMBH (FED REP GERMANY LIMITED COMPANY (GERMAN GMBH)) KOCHSTRASSE 6, 59379 SELM, FED REP GERMANY., SN 79-024,614. FILED 3-22-2006. PRINCIPAL REGISTER.



PRIORITY DATE OF 10-18-2005 IS CLAIMED.  
OWNER OF INTERNATIONAL REGISTRATION 0886899 DATED 3-22-2006, EXPIRES 3-22-2016.

THE COLOR(S) WHITE, BLACK, YELLOW, ORANGE, BROWN AND YELLOW-BROWN IS/ARE CLAIMED AS A FEATURE OF THE MARK.

THE MARK CONSISTS OF THE COLOR WHITE AS THE BACKGROUND, BLACK AND BROWN AS THE CENTERPIECE OF THE FLOWERS UNDERNEATH THE LETTERS "SUNNY SUSY", YELLOW, YELLOW-BROWN AND ORANGE AS THE PETALS OF THE FLOWERS UNDERNEATH THE LETTERS "SUNNY SUSY", YELLOW-BROWN AS THE LETTERS "SUNNY SUSY", ORANGE AS THE OUTLINE OF THE FLOWER ON THE LEFT SIDE OF THE DRAWING.

INT. CL. 31/U.S. CLS. 1 AND 46

FOR [ AGRICULTURAL, HORTICULTURAL AND FORESTRY PRODUCTS AS FAR AS INCLUDED IN THIS CLASS, NAMELY, SEEDS AND BULBS FOR AGRICULTURAL PURPOSES, AGRICULTURAL SEEDS, SPORES AND SPAWN FOR AGRICULTURAL PURPOSES, AGRICULTURAL GRAINS FOR PLANTING, SEEDS AND BULBS FOR HORTICULTURAL PURPOSES, LIVING TREES, NON-DEBARKED TIMBER, UNSAWN TIMBER, RAW TIMBER, UNPROCESSED TIMBER; GRAINS, NAMELY, UNPROCESSED GRAINS, AGRICULTURAL AND HORTICULTURAL GRAINS FOR PLANTING; ] NATURAL PLANTS AND FLOWERS, NAMELY, LIVE FLOWERING PLANTS, LIVING PLANTS, [ LIVING FRUIT PLANTS, ] LIVE FLOWERS [ FOODSTUFFS FOR ANIMALS, MALT FOR BREWING AND DISTILLING ].

FIRST USE ; IN COMMERCE .

ELEMENTS CORRECTED  
GOODS/SERVICES

3,324,826. REG. 10-30-2007. ROUTIN (FRANCE SOCIÉTÉ ANONYME) 907, RUE EMILE ROMANET, ZI DE BISSY; F-73000 CHAMBERY, FRANCE., SN 79-026,488. FILED 5-26-2006. PRINCIPAL REGISTER.

# MONTANIA

THE MARK CONSISTS OF STANDARD CHARACTERS WITHOUT CLAIM TO ANY PARTICULAR FONT, STYLE, SIZE, OR COLOR.

PRIORITY DATE OF 12-6-2005 IS CLAIMED.  
OWNER OF INTERNATIONAL REGISTRATION 0892165 DATED 5-26-2006, EXPIRES 5-26-2016.

INT. CL. 32/U.S. CLS. 45, 46 AND 48

FOR BEERS; FRUIT DRINKS AND FRUIT JUICES; SYRUPS AND OTHER PREPARATIONS FOR MAKING BOTH CARBONATED AND NON-CARBONATED NON-ALCOHOLIC FRUIT BEVERAGES; LEMONADES, FRUIT NECTARS, SOFT DRINKS, NON-ALCOHOLIC APERITIFS.

ELEMENTS CORRECTED  
OWNER ADDRESS  
[GOODS/SERVICES]  
[INTERNATIONAL CLASS(ES)]



3,362,637. REG. 1-1-2008. SENZ TECHNOLOGIES B.V. (NETHERLANDS CORPORATION) MIJNBOWWSTRAAT 120, NL-2628 RX DELFT, NETHERLANDS., SN 79-026,430. FILED 7-7-2006. PRINCIPAL REGISTER.

# SENZ

THE MARK CONSISTS OF STANDARD CHARACTERS WITHOUT CLAIM TO ANY PARTICULAR FONT, STYLE, SIZE, OR COLOR.

PRIORITY DATE OF 1-30-2006 IS CLAIMED.  
OWNER OF INTERNATIONAL REGISTRATION 0891967 DATED 7-7-2006, EXPIRES 7-7-2016.

INT. CL. 18/U.S. CLS. 1, 2, 3, 22 AND 41

FOR LEATHER AND IMITATIONS OF LEATHER, AND GOODS MADE OF THESE MATERIALS AND NOT INCLUDED IN OTHER CLASSES, NAMELY, LEATHER BRIEFCASES, LEATHER BAGS, LEATHER HANDBAGS, LEATHER BAGS FOR MERCHANDISE PACKAGING, LEATHER CASES, LEATHER SUITCASES, TRAVELLING CASES OF LEATHER, LEATHER PURSES, LEATHER SHOPPING BAGS, POUCHES OF LEATHER, LEATHER WALLETS, LEATHER BOXES FOR STORING GREETING CARDS, LEATHER KEYCASES, LEATHER CASES FOR KEYS, LEATHER KEY CHAINS, LEATHER FOR FURNITURE, LEATHER FOR HARNESSSES, LEATHER FOR SHOES, LEATHER SOLD IN BULK, LEATHER STRAPS, LEATHER THREAD, LEATHER POUCHES FOR HOLDING DISPOSABLE BAGS TO PLACE PET WASTE IN, TANNED LEATHER, LEATHER THONGS; ANIMAL SKINS, HIDES; TRUNKS AND TRAVELLING BAGS \* USED OUTSIDE \*; UMBRELLAS, PARASOLS AND WALKING STICKS; WHIPS, HARNESS AND SADDLERY.

FIRST USE ; IN COMMERCE .  
INT. CL. 22/U.S. CLS. 1, 2, 7, 19, 22, 42 AND 50

FOR ROPES, STRING, BUTTERFLY NETS, FISHING NETS, TENTS, AWNINGS, TARPULINS, SAILS, SACKS AND BAGS FOR THE TRANSPORTATION OR STORAGE OF MATERIALS IN BULK; PADDING AND STUFFING MATERIALS NOT OF RUBBER, PAPER OR PLASTICS; RAW FIBROUS TEXTILE MATERIALS.

FIRST USE ; IN COMMERCE .

ELEMENTS CORRECTED  
\*CITIZENSHIP\*  
GOODS/SERVICES  
ENTITY

3,390,654. REG. 3-4-2008. EVONIK INDUSTRIES AG (FED REP GERMANY CORPORATION) RELLINGHAUSER STRABE 1-11, ESSEN, FED REP GERMANY, 45128, SN 77-013,645. FILED 10-4-2006. PRINCIPAL REGISTER.

# EVONIK

THE MARK CONSISTS OF STANDARD CHARACTERS WITHOUT CLAIM TO ANY PARTICULAR FONT, STYLE, SIZE, OR COLOR.

OWNER OF FED REP GERMANY REG. NO. 30623280.4, DATED 9-7-2006, EXPIRES 4-7-2016.  
INT. CL. 35/U.S. CLS. 100, 101 AND 102

FOR ADVERTISING; BUSINESS ADMINISTRATION AND ORGANIZATIONAL PROJECT DEVELOPMENT FOR OTHERS; BUSINESS CONSULTANCY FOR POWER PLANTS AND INCINERATION PLANTS IN THE AREAS OF RESIDUE AND WASTE DISPOSAL; SECRETARIAL SERVICES; COMPILATION OF STATISTICS FOR BUSINESS PURPOSES; ACCOUNTING SERVICES; ACCOUNTING, NAMELY, BOOKKEEPING; AUCTIONEERING; BUSINESS INVESTIGATIONS; BUSINESS MARKETING; MARKET RESEARCH AND MARKET ANALYSIS; BUSINESS ADMINISTRATION CONSULTANCY, BUSINESS MANAGEMENT CONSULTANCY, AND BUSINESS ORGANIZATION CONSULTANCY; BUSINESS CONSULTING SERVICES RELATING TO PRODUCT DISTRIBUTION, MARKETING, OPERATIONS, MANAGEMENT, LOGISTICS, REVERSE LOGISTICS, SUPPLY CHAINS, STRATEGY, PRODUCTION, PERSONNEL, AND RETAIL SALE MATTERS; BUSINESS ADMINISTRATIVE CONSULTANCY, PROFESSIONAL BUSINESS CONSULTANCY, PERSONNEL MANAGEMENT CONSULTANCY; RENTAL OF OFFICE MACHINERY AND EQUIPMENT; ARRANGING AND CONCLUDING BUSINESS NEGOTIATIONS FOR OTHERS IN THE FIELD OF COMMERCIAL TRANSACTIONS; MEDIATION OF CONTRACTS FOR THE BUYING AND SELLING OF GOODS FOR OTHERS; REPRODUCTION OF DOCUMENTS; ORGANIZATION OF FAIRS AND EXHIBITIONS FOR COMMERCIAL OR ADVERTISING PURPOSES; MEDIATING CONTRACTS WITH ELECTRIC POWER SUPPLIERS FOR THE PURCHASE AND SALE OF ELECTRICAL SERVICES FOR OTHERS; RENTAL OF DATA PROCESSING EQUIPMENT.

FIRST USE ; IN COMMERCE .

ELEMENTS CORRECTED  
OWNER NAME

3,411,318. REG. 4-15-2008. EVONIK INDUSTRIES AG (FED REP GERMANY CORPORATION) RELLINGHAUSER STRABE 1-11, ESSEN, FED REP GERMANY, 45128, SN 77-013,628. FILED 10-4-2006. PRINCIPAL REGISTER.

# EVONIK

THE MARK CONSISTS OF STANDARD CHARACTERS WITHOUT CLAIM TO ANY PARTICULAR FONT, STYLE, SIZE, OR COLOR.

OWNER OF FED REP GERMANY REG. NO. 30623280.4, DATED 9-7-2006, EXPIRES 4-7-2016.  
INT. CL. 17/U.S. CLS. 1, 5, 12, 13, 35 AND 50

FOR SYNTHETIC RUBBER; SYNTHETIC RUBBER FOR USE IN THE MANUFACTURE OF TIRES; UNCURED SYNTHETIC RUBBER FOR USE IN THE MANUFACTURE OF A WIDE VARIETY OF GOODS; CHLORINATED RUBBER; CRUDE RUBBER; CUSHIONING OF RUBBER IN THE NATURE OF STUFFING; ELECTRICAL INSULATING RUBBER PRODUCTS; FIGURINES MADE OF RUBBER; FLUORO RUBBER; FOAM RUBBER; GENERAL PURPOSE SILICONE RUBBER SEALANT; HYDROCHLORINATED RUBBER; INDUSTRIAL PACKAGING CONTAINERS OF RUBBER; ISOBUTYLENE-ISOPRENE RUBBER; LIQUID RUBBER; NATURAL RUBBER; PACKING AND PADDING OF RUBBER FOR SHIPPING CONTAINERS; PADDING OF RUBBER FOR SHIPPING CONTAINERS; POLYSULFIDE RUBBER; RECLAIMED RUBBER; RAW RUBBER; SEMIWORKED RUBBER; RUBBER BANDS FOR COMMERCIAL AND INDUSTRIAL USES; RUBBER BARS AND RODS; RUBBER BOTTLE STOPPERS; RUBBER BUMPERS FOR LOADING DOCKS; RUBBER DERIVATIVES; RUBBER PACKING FOR SHIPPING CONTAINERS; RUBBER SHEETS; RUBBER SHOCK ABSORBERS FOR INDUSTRIAL MACHINERY; RUBBER SLEEVES FOR PROTECTING PARTS OF MACHINERY; RUBBER SOLUTIONS; RUBBER STOPPERS FOR INDUSTRIAL

PACKAGING CONTAINERS; RUBBER THREAD NOT FOR TEXTILE USE; RUBBER TUBES AND PIPES; RUBBER WHEEL CHOCKS; SEALING PLUGS MADE PRIMARILY FROM RUBBER; SHOCK ABSORBING RUBBER BUFFERS FOR INDUSTRIAL MACHINERY; SHOCK BUFFERS OF RUBBER FOR INDUSTRIAL MACHINERY; SILICONE RUBBER; SLEEVES OF RUBBER FOR PROTECTING PARTS OF MACHINERY; STUFFING OF RUBBER; STYRENE-BUTADIENE RUBBER; VALVES OF RUBBER OR VULCANIZED FIBER; GUM AND GUTTA-PERCHA, IN PELLET AND GRANULE FORM, FOR USE IN THE MANUFACTURE OF INDUSTRIAL PRODUCTS, PADDING MATERIAL AND CUSHIONING, AND TIRES; ASBESTOS BOARDS, CORDS, STRINGS AND FELT; ASBESTOS FABRIC FOR USE AS CABLE INSULATION; ASBESTOS FIRE CURTAINS; ASBESTOS FOR USE IN THE MANUFACTURE OF BRAKE LININGS; ASBESTOS NETS; ASBESTOS PACKING FOR VALVES AND PISTONS; ASBESTOS PAPER, POWDER AND YARN; PACKING, STOPPING AND INSULATING MATERIALS, NAMELY, GRAPHITE PACKING FOR GASKETS; GRAPHITE PACKING FOR PUMPS, GASKETS, AND VALVES; MOLDABLE COMPOUNDS FOR USE IN PACKING; MOLDED FOAM INSULATED CONTAINER PACKING FOR COMMERCIAL TRANSPORTATION; PACKING FOAM IN SHEET FORM; PACKING MATERIAL FOR FORMING SEALS; PACKING PADDING OF PLASTIC FOR SHIPPING CONTAINERS; PACKING PADDING OF RUBBER FOR SHIPPING CONTAINERS; PLASTIC PACKING FOR SHIPPING CONTAINERS; RUBBER PACKING FOR SHIPPING CONTAINERS; ELECTRICAL INSULATING TAPE; ELECTRICAL INSULATING MICA PRODUCTS; ELECTRICAL INSULATING RUBBER PRODUCTS; INSULATING AND PROTECTIVE INTERLAYER DIELECTRIC MATERIALS AND COATINGS FOR USE IN INTEGRATED CIRCUITS, SEMICONDUCTOR DEVICES, COMPUTER DISK DRIVES AND OTHER COMPUTER HARDWARE; INSULATING BLANKETS FOR HOT WATER HEATERS; INSULATING BLANKETS MADE OF SILICA FIBERS, INSULATING FILM FOR USE IN THE MANUFACTURE OF SEMICONDUCTORS; INSULATING GLOVES; POLYURETHANE FOAM AND POLYETHYLENE FOAM; INSULATING OIL FOR TRANSFORMERS; INSULATING PAINT; INSULATING PLASTER; INSULATING REFRACTORY MATERIALS; INSULATING SLEEVES FOR POWER LINES; INSULATING SLEEVES FOR WATER HEATERS; INSULATING SPLICE COVER FOR ELECTRICAL CABLE; INSULATING STRUCTURAL PANELS FOR PLACEMENT ON EDIFICES; INSULATING TILES; INSULATING WATER PROOFING MEMBRANES; INSULATING WATER PROOFING TILES; AND POLYURETHANE FILM FOR USE IN SEALING AND INSULATING BUILDINGS; MICA; RAW MICA; PARTLY PROCESSED MICA; PLASTICS IN EXTRUDED FORM FOR USE IN MANUFACTURING; FLEXIBLE PIPES, NOT OF METAL; NON-METAL TUBING AND TUBING COUPLINGS FOR JOINING AND TERMINATING PIPES.

FIRST USE : IN COMMERCE .

ELEMENTS CORRECTED  
OWNER NAME

3,411,321. REG. 4-15-2008. EVONIK INDUSTRIES AG (FED REP GERMANY CORPORATION) RELLINGHAUSER STRABE 1-11, ESSEN, FED REP GERMANY, 45128. SN 77-013,665. FILED 10-4-2006. PRINCIPAL REGISTER.

**EVONIK**

THE MARK CONSISTS OF STANDARD CHARACTERS WITHOUT CLAIM TO ANY PARTICULAR FONT, STYLE, SIZE, OR COLOR.

OWNER OF FED REP GERMANY REG. NO. 30623280.4, DATED 9-7-2006, EXPIRES 4-7-2016. INT. CL. 39/U.S. CLS. 100 AND 105

FOR TRANSPORT OF CHEMICALS; TRANSPORT OF GOODS; STORAGE OF CHEMICALS; SUPPLYING AND DISTRIBUTION OF ENERGY, ELECTRICITY, GAS, HEAT AND DISTRICT HEAT, COMPRESSED AIR AND/OR WATER; TRANSPORT OF GASES, LIQUIDS AND SOLIDS BY PIPE-LINE; VEHICLE TOWING, TRANSPORT OF PERSONS AND GOODS BY CAR, RAIL, SHIP AND AIRPLANE; CRANE RENTAL AND LEASING FOR CARGO HANDLING, CARGO SHIP TRANSPORT, AND CARGO UNLOADING; STORAGE OF FURNITURE; GUARDED TRANSPORT OF MONEY AND VALUABLES BY TRUCK, BOAT, AIRPLANE, CAR AND RAIL; AMBULANCE TRANSPORT; TRAVEL ARRANGEMENT; ARRANGEMENT OF TRAFFIC CAPACITY, NAMELY, TRAFFIC INFORMATION; TRAFFIC MANAGEMENT SERVICES, NAMELY, CREATING SPECIAL EVENT TRAFFIC PLANS FOR OTHERS; GARAGE AND PARKING SPACE RENTAL, CAR RENTAL, AND PACKAGING OF ARTICLES FOR TRANSPORTATION.

ELEMENTS CORRECTED  
OWNER NAME

3,432,840. REG. 5-20-2008. PAKSENSE, INC. (DELAWARE CORPORATION) 9939 WEST EMERALD, BOISE, ID, 83704. SN 78-718,347. FILED 9-22-2005. PRINCIPAL REGISTER.



**PAKSENSE**

THE COLOR(S) RED, BLUE, BLACK AND WHITE IS/ARE CLAIMED AS A FEATURE OF THE MARK.

THE MARK CONSISTS OF THE COLOR RED APPEARS IN THE DESIGN OF THE TOP PANEL OF THE CUBE AND IN THE UNDERScore BENEATH THE WORDING. THE COLOR BLUE APPEARS IN THE DESIGN OF THE TWO SIDE PANELS OF THE CUBE. THE COLOR BLACK APPEARS IN THE WORDING "PAKSENSE." AND THE COLOR WHITE APPEARS IN THE WAVEFORM IN THE TOP PANEL OF THE CUBE AND AS THE BORDER BETWEEN THE TOP PANEL AND THE SIDE PANELS AND IN BETWEEN THE SIDE PATTERNS.

INT. CL. 9/U.S. CLS. 21, 23, 26, 36 AND 38  
FOR ELECTRIC AND ELECTRONIC SENSORS AND SENSOR CARDS ATTACHED TO OR EMBEDDED IN LABELS AND PACKAGING TO MONITOR, AND REPORT THE ENVIRONMENTAL STATUS AND FRESHNESS OF PRODUCTS.

FIRST USE 12-5-2004; IN COMMERCE 4-6-2006.

ELEMENTS CORRECTED  
OWNER NAME  
OWNER ADDRESS  
DATE OF FIRST USE  
DATE OF FIRST USE IN COMMERCE

3,433,828. REG. 5-27-2008. EVONIK INDUSTRIES AG (FED REP GERMANY CORPORATION) RELLINGHAUSER STRABE 1-11, ESSEN, FED REP GERMANY, 45128, SN 77-013,601. FILED 10-4-2006. PRINCIPAL REGISTER.

# EVONIK

THE MARK CONSISTS OF STANDARD CHARACTERS WITHOUT CLAIM TO ANY PARTICULAR FONT, STYLE, SIZE, OR COLOR.

OWNER OF FED REP GERMANY REG. NO. 30623280.4, DATED 9-7-2006, EXPIRES 4-7-2016.

INT. CL. 11/U.S. CLS. 13, 21, 23, 31 AND 34

FOR APPARATUSES FOR LIGHTING, NAMELY, ELECTRIC LIGHTING FIXTURES AND SCONCES; ELECTRIC TORCHES; ELECTRIC TRACK LIGHTING UNITS; FIBER OPTIC LIGHTING FIXTURES USED IN CONJUNCTION WITH ELECTRICAL ILLUMINATORS; FLUORESCENT LIGHTING TUBES; INFRARED LIGHTING FIXTURES; LANDSCAPE LIGHTING INSTALLATIONS; LIGHTING DEVICES FOR SHOWCASES; LIGHTING FIXTURES FOR USE IN PARKING DECKS AND GARAGES; LIGHTING FIXTURES FOR USE IN PARKING LOTS AND WALKWAYS; LIGHTING FIXTURES THAT INTEGRATE NATURAL DAYLIGHT AND FLUORESCENT LIGHTING; LIGHTING TRACKS; LIGHTING TUBES; PAVER LIGHTS; INDOOR AND OUTDOOR SOLAR-POWERED LIGHTING UNITS AND FIXTURES; APPARATUSES FOR HEATING, NAMELY, CHEMICALLY ACTIVATED HEATING PACKS FOR PROVIDING WARMTH TO THE BODY NOT FOR MEDICAL PURPOSES; ELECTRIC HEATING FANS; ELECTRIC RADIATORS FOR HEATING BUILDINGS; ELECTRICAL HEATING CABLES; ELECTRICAL HEATING TAPES, ELECTRICAL INDUCTION HEATING APPARATUS FOR HEATING METAL WORKPIECES; HEAT SINKS FOR USE IN HEATING AND VENTILATING APPARATUS; HEATING AND COOLING PACKS FILLED WITH CHEMICAL SUBSTANCES THAT REACT WHEN REQUIRED TO WARM OR COOL THE BODY NOT FOR MEDICAL PURPOSES; ELECTRIC AND CHEMICALLY ACTIVATED HEATING CUSHIONS NOT FOR MEDICAL PURPOSES; HEATING FURNACES FOR INDUSTRIAL PURPOSES; ELECTRIC AND CHEMICALLY ACTIVATED HEATING PADS NOT FOR MEDICAL PURPOSES; HEATING SYSTEMS COMPOSED PRIMARILY OF TUBES, PIPES AND PRE-ASSEMBLED MANIFOLDS THROUGH WHICH COLD OR LOW TEMPERATURE WATER CIRCULATES; HOT-AIR SPACE HEATING APPARATUS FOR INDUSTRIAL PURPOSES; HOT WATER SPACE HEATING APPARATUS FOR INDUSTRIAL PURPOSES; INDUCTION HEATERS FOR HEATING THERMAL INSULATED DELIVERY BAGS DESIGNED TO KEEP FOOD WARM DURING TRANSPORT; INDUSTRIAL DRYERS FOR HEATING AND DEHUMIDIFYING; CHEMICALLY ACTIVATED HEATING PACKETS FOR WARMING HANDS NOT FOR MEDICAL USE; PAVEMENT HEATING APPARATUS; PELTIER HEATING APPARATUS; PIPES FOR HEATING BOILERS; PORTABLE THERMAL SELF-HEATING POUCH FOR THE PURPOSES OF HEATING FOOD; PORTABLE THERMOELECTRIC COOLING AND HEATING UNIT FOR FOOD AND BEVERAGES; STEAM HEATING APPARATUS FOR INDUSTRIAL PURPOSES; STEAM RADIATORS FOR HEATING BUILDINGS; AND THERMOSTATIC VALVES FOR HEATING INSTALLATIONS; APPARATUSES FOR COOKING, NAMELY, ELECTRIC COOKING OVENS; GAS COOKING OVENS; COMMERCIAL COOKING OVENS; DOMESTIC COOKING OVENS; INDUSTRIAL COOKING OVENS; LINERS FOR CONVENTIONAL OVENS IN THE NATURE OF HEAT TRANSMITTING CONTAINERS FOR PROVIDING UNIFORM HEAT AND HUMIDITY DURING COOKING; COOKING RANGES; ELECTRIC COOKING POTS; GAS STOVES; ELECTRIC STOVES; JAPANESE CHARCOAL COOKING STOVES FOR HOUSEHOLD PURPOSES; MICROWAVE OVENS; AND OIL COOKING STOVES FOR HOUSEHOLD PURPOSES; WATER SUPPLY APPARATUSES, NAMELY, ELECTRONIC GENERATORS FOR USE IN CONTROLLING THE AMOUNT OF HUMIDITY IN THE AIR BY CREATING, REMOV-

ING OR CIRCULATING SMALL WATER PARTICLES OR WATER VAPOR IN THE AIR; REVERSE OSMOSIS WATER FILTRATION UNITS; FLOW RESTRICTORS FOR REVERSE OSMOSIS WATER PURIFICATION UNITS; GAS WATER HEATERS; HOT WATER HEATERS; HOT WATER TANKS; INDUSTRIAL WATER PURIFYING APPARATUS; MACHINES THAT GENERATES PURIFIED WATER FROM THE ATMOSPHERE AND SIMULTANEOUSLY PURIFY THE AIR; OXYGEN GENERATOR FOR PROCESSING WATER BY INCREASING OXYGEN CONTENT IN THE WATER; OZONE SANITIZERS FOR WATER; SOLAR WATER HEATERS; TAP WATER FAUCETS; TAP WATER PURIFYING DEVICES; THICKENING AND DEWATERING MACHINES FOR USE IN THE TREATMENT OF LIQUIDS INCLUDING WATER; INDUSTRIAL EFFLUENT AND SEWAGE, WASTE WATER PURIFICATION UNITS; WATER BED HEATERS; WATER COOLING TOWERS; WATER DESALINATION PLANTS; WATER DISTILLATION UNITS; WATER FAUCET SPOUTS; WATER PURIFICATION INSTALLATIONS FOR WASTE WATER AND SEWAGE CONSISTING OF CURTAINS AND TEXTILE FABRICS; WATER FILTERING UNITS FOR DOMESTIC, COMMERCIAL AND INDUSTRIAL USE; WATER FOUNTAINS; WATER IONIZERS FOR HOUSEHOLD PURPOSES; WATER PURIFICATION TANKS AND UNITS FOR DOMESTIC, COMMERCIAL AND INDUSTRIAL USE; WATER SOFTENING UNITS; CARTRIDGE FILTRATION UNITS; AND CHEMICAL AND ULTRAVIOLET WATER STERILIZATION UNITS; DRYING APPARATUSES, NAMELY, CLOTHES DRYERS; DRYERS FOR THE REMOVAL OF WATER VAPOR FROM COMPRESSED AIR AND GASES; DRYERS USED FOR THE REMOVAL OF SOLID, LIQUID AND VAPOR CONTAMINANTS FROM COMPRESSED AIR AND GASES; ELECTRIC HOT AIR HAND DRYERS; HAIR DRYERS FOR HOUSEHOLD PURPOSES; HAND HELD ELECTRIC HAIR DRYERS; INDUSTRIAL DRYERS FOR HEATING AND DEHUMIDIFYING; AND STATIONARY HAIR DRYERS FOR COMMERCIAL AND DOMESTIC USE; VENTILATING APPARATUSES, NAMELY, EXHAUST FANS; VENTILATING FANS FOR COMMERCIAL AND INDUSTRIAL USE; AND VENTILATING LOUVERS; STEAM GENERATORS; REFRIGERATING MACHINES; SANITARY PIPES FOR SANITARY PURPOSES; PURIFICATION INSTALLATIONS FOR SEWAGE, NAMELY, SEWAGE TREATMENT PLANTS; AND REACTORS FOR THE CHEMICAL INDUSTRY, NAMELY, NUCLEAR REACTORS; MACHINES FOR AIR CONDITIONING.

FIRST USE ; IN COMMERCE .

ELEMENTS CORRECTED  
OWNER NAME

3,433,829. REG. 5-27-2008. EVONIK INDUSTRIES AG (FED REP GERMANY CORPORATION) RELLINGHAUSER STRABE 1-11, ESSEN, FED REP GERMANY, 45128, SN 77-013,611. FILED 10-4-2006. PRINCIPAL REGISTER.

# EVONIK

THE MARK CONSISTS OF STANDARD CHARACTERS WITHOUT CLAIM TO ANY PARTICULAR FONT, STYLE, SIZE, OR COLOR.

OWNER OF FED REP GERMANY REG. NO. 30623280.4, DATED 9-7-2006, EXPIRES 4-7-2016.

INT. CL. 16/U.S. CLS. 2, 5, 22, 23, 29, 37, 38 AND 50

FOR PAPER GOODS, NAMELY, TRANSPARENT, OPAQUE AND TRANSLUCENT FILMS FOR USE WITH INK JET COPIES AND LASER PRINTERS; ADVERTISING BOARDS OF PAPER OR CARDBOARD; ADVERTISING SIGNS OF PAPER OR CARDBOARD; ALUMINUM FOIL LAMINATED PAPER FOR PRINTING PURPOSES; ART PAPER; BABIES' DIAPERS OF PAPER; BOOK-COVER PAPER; COMPUTER PAPER; CONSTRUCTION PAPER; COPY PAPER; DIGITAL PRINTING PAPER; DIRECTORY PAPER; DRAWING PAPER; ENVELOPE PAPER; FACSIMILE TRANSMISSION PAPER; LASER PRINT PAPER; TYPEWRITER PAPER; LETTER PAPER BEING FINISHED PRODUCTS; OFFSET PAPER; PAPER FOR PHOTOCOPIERS; PAPER FOR RECORDING MACHINES; PAPER FOR USE IN THE GRAPHIC ARTS INDUSTRY; PUBLICATION PAPER; REEL PAPER FOR PRINTERS; SEMI-PROCESSED PAPER; SYNTHETIC PAPER; PAPER BOXES; PAPER BAGS; AND PAPER FOR WRAPPING AND PACKAGING; CARDBOARD GOODS, NAMELY, ADVERTISING BOARDS; BOXES, CARTONS, AND CONTAINERS; BACKING FOR BINDING BOOKS; CARRIERS FOR FOODS AND BEVERAGES; FLOOR DISPLAYS FOR MERCHANDISING PRODUCTS; HANG TAGS; MAILING TUBES; PACKAGING; CONTAINERS FOR ICE; LINERBOARD; PICTURE MOUNTS; AND PLACARDS; BOOKBINDING MATERIAL, NAMELY, BOOKBINDINGS; BOOKBINDING TAPE; BOOKBINDING WIRE; AND CLOTH FOR BOOKBINDING; PHOTOGRAPHS; STATIONERY; ADHESIVES FOR STATIONERY FOR HOUSEHOLD PURPOSES; ARTISTS' MATERIALS, NAMELY, BRUSHES; PASTELS; PENCILS; PENS; CANVAS; AND MOLDS FOR MODELING CLAY; ELECTRONIC TYPEWRITERS; TYPEWRITER RIBBONS; PRINTBALLS AND TYPEBALLS; PRINTED INSTRUCTIONAL AND TEACHING MATERIAL IN THE FIELDS OF TELECOMMUNICATIONS AND EDUCATION; OFFICE REQUISITES, NAMELY, STAPLERS; RUBBER BANDS; ENVELOPE SEALING MACHINES; ADHESIVE TAPE DISPENSERS; ADHESIVE APPLYING MACHINES FOR HOME AND OFFICE USE; AUTOMATIC ADHESIVE DISPENSERS FOR OFFICE USE; AUTOMATIC PAPER CLIP DISPENSING MACHINES FOR OFFICE OR STATIONERY USE; BINDERS; CD SHREDDERS; COLLECTORS; CORRECTING FLUID FOR TYPE; DOCUMENT BINDING MACHINES FOR OFFICE USE; DOCUMENT LAMINATORS FOR OFFICE USE; ELECTRIC STAPLERS FOR OFFICES; FINGER STALLS; FRANKING MACHINES; GLUE; IMPRINTERS; INK ROLLERS FOR OFFICE MACHINES; LAMINATING MACHINES FOR HOME AND OFFICE USE; LETTER INSERTER MACHINES FOR OFFICE USE; OFFICE CHECK WRITING AND ENGRAVING MACHINES; DECOLLATING MACHINES; HOLE PUNCHERS; LABELING MACHINES; LETTERING MACHINES; OFFICE MACHINE RIBBONS; PAPER DRILL MACHINES; TYPE COMPOSING MACHINES; EMBOSSERS; PAPER FOLDING MACHINES; PAPER SHREDDERS; PAPER FEEDING MACHINES; PROTRACTORS; PUNCHES; RUBBER BANDS; SEALS; AND SPIRAL BINDING MACHINES; PLASTIC MATERIALS FOR PACKAGING, NAMELY, PLASTIC BAGS AND PLASTIC BUBBLE PACKS; OTHER PACKAGING MATERIAL, NAMELY, ABSORBENT PADS OF PAPER AND CELLULOSE FOR USE IN FOOD PACKAGING; INDUSTRIAL PACKAGING CONTAINERS OF PAPER; PACKAGING AND CONTAINERS COMPRISED OF STARCH-BASED MATERIALS IN THE NATURE OF A PAPER SUBSTITUTE FOR FOOD, BEVERAGES AND CONSUMER PRODUCTS; PAPER CONTAINERS FOR FOOD AND BEVERAGES COMPRISED OF MATERIALS DESIGNED TO LESSEN ADVERSE EFFECTS ON THE ENVIRONMENT; PAPER POUCHES FOR PACKAGING; PAPER ENVELOPES; AND VEGETABLE PARCHMENT FOR USE IN FOOD WRAPPING, PREPARATION, PROCESSING AND PACKAGING.

FIRST USE ; IN COMMERCE .

ELEMENTS CORRECTED  
OWNER NAME

3,447,431. REG. 6-17-2008. OSMENT, DAVID L. (UNITED STATES INDIVIDUAL) 1350 NOBLE HERON WAY, NAPLES, FL, 34105, SN 77-029,030. FILED 10-25-2006. PRINCIPAL REGISTER.

## SCENEARAMA

THE MARK CONSISTS OF STANDARD CHARACTERS WITHOUT CLAIM TO ANY PARTICULAR FONT, STYLE, SIZE, OR COLOR.

INT. CL. 28/U.S. CLS. 22, 23, 38 AND 50

FOR HOBBY CRAFT KITS FOR USE IN CONSTRUCTING DISPLAYS AND DIORAMAS, CONSISTING PRIMARILY OF MINIATURE REPRESENTATIONS OF NATURAL AND MAN-MADE OBJECTS.

FIRST USE 10-19-2006; IN COMMERCE 10-19-2006.

ELEMENTS AMENDED  
OWNER ADDRESS  
MARK

3,475,156. REG. 7-29-2008. RODOLFO SEALTIEL RIVA PALACIO ALATRISTE (MEXICO INDIVIDUAL) COLONIA DEL VALLE, LUZ SAVINON 513, PISO 2, MEXICO, D.F., MEXICO, 03100, AND GABRIEL ENRIQUE RIVA PALACIO ALATRISTE (MEXICO INDIVIDUAL) COLONIA DEL VALLE, LUZ SAVINON 513, PISO 2, MEXICO, D.F., MEXICO, 03100, SN 77-255,079. FILED 8-14-2007. PRINCIPAL REGISTER.

## THE BONES FAMILY

THE MARK CONSISTS OF STANDARD CHARACTERS WITHOUT CLAIM TO ANY PARTICULAR FONT, STYLE, SIZE, OR COLOR.

PRIORITY CLAIMED UNDER SEC. 44(D) ON MEXICO APPLICATION NO. 874697, FILED 8-10-2007, REG. NO. 1003838, DATED 9-25-2007, EXPIRES 8-10-2017.

PRIORITY CLAIMED UNDER SEC. 44(D) ON MEXICO APPLICATION NO. 874698, FILED 8-10-2007, REG. NO. 1003839, DATED 9-25-2007, EXPIRES 8-10-2017.

INT. CL. 38/U.S. CLS. 100, 101 AND 104

FOR DATA TRANSMISSION AND RECEPTION SERVICES VIA TELECOMMUNICATION MEANS; PROVIDING ON-LINE COMMUNICATIONS LINKS WHICH TRANSFER THE WEBSITE USER TO OTHER LOCAL AND GLOBAL WEB PAGES; TRANSMISSION OF INFORMATION ON OPTICAL TELECOMMUNICATION NETWORKS; TRANSMISSION OF DATABASE INFORMATION VIA TELECOMMUNICATIONS NETWORKS; ELECTRONIC EXCHANGE OF DATA STORED IN DATABASES ACCESSIBLE VIA TELECOMMUNICATION NETWORKS; BROADCAST OF CABLE TELEVISION PROGRAMMES.

INT. CL. 41/U.S. CLS. 100, 101 AND 107

FOR (BASED ON 44(D) PRIORITY APPLICATION) ENTERTAINMENT IN THE NATURE OF ON-GOING TELEVISION PROGRAMS IN THE FIELD OF CARTOON SHOWS; ENTERTAINMENT NAMELY, PRODUCTION OF TELEVISION CARTOON SHOWS; ENTERTAINMENT, NAMELY A CONTINUING CARTOON SHOW BROADCAST OVER TELEVISION, SATELLITE, AUDIO, AND VIDEO MEDIA; TELEVISION PRODUCTION; ANIMATION PRODUCTION SERVICES; DIRECTION OF MAKING RADIO OR TELEVISION PROGRAMS; PRODUCTION OF CABLE TELEVISION PROGRAMS; PRODUCTION OF CLOSED CAPTION TELEVISION PROGRAMS; PROVISION OF NON-DOWNLOADABLE FILMS AND TV PROGRAMMES VIA A VIDEO-ON-DEMAND SERVICE; PRODUCTION AND DISTRIBUTION OF MOTION PICTURES; ENTERTAINMENT IN THE NATURE OF TELEVISION PROGRAMS FEATURING CARTOON SHOWS.

ELEMENTS CORRECTED  
\*PRIORITY CLAIMED STATEMENT\*

3,533,051. REG. 11-18-2008. EVONIK INDUSTRIES AG (FED REP GERMANY CORPORATION) RELLINGHAUSER STRABE 1-11, ESSEN, FED REP GERMANY, 45128, SN 77-195,576. FILED 6-1-2007. PRINCIPAL REGISTER.



PRIORITY CLAIMED UNDER SEC. 44(D) ON FED REP GERMANY APPLICATION NO. 30674165.2/3, FILED 12-2-2006, REG. NO. 30674165, DATED 12-2-2006, EXPIRES 12-31-2016.

THE COLOR(S) PURPLE AND GRAY IS/ARE CLAIMED AS A FEATURE OF THE MARK.

THE MARK CONSISTS OF THE COLOR DARK PURPLE OUTLINED WITH LIGHT PURPLE AND DARK GREY APPEARS IN THE INTERIOR "E" SHAPED DESIGN; THE COLOR LIGHT GRAY OUTLINED WITH DARK GREY AND WHITE APPEARS IN THE EXTERIOR CIRCULAR DESIGN.

INT. CL. 1/U.S. CLS. 1

FOR CHEMICALS USED IN INDUSTRY, SCIENCE AND PHOTOGRAPHY; CHEMICALS FOR USE IN THE BIOCHEMICAL AND CHEMICAL INDUSTRY; CHEMICALS USED IN AGRICULTURE, HORTICULTURE AND FORESTRY, NAMELY, AS FERTILIZER AND FOR THE TREATMENT OF SEEDS; CHEMICALS USED IN WINE MAKING, NAMELY, ETHANOL, AND CHEMICALS FOR FERMENTING WINE; CHEMICALS USED IN THE TEXTILE AND PAPER INDUSTRIES, NAMELY, PRECIPITATED AND FUMED SILICA, HYDROGEN PEROXIDES, STARCH, SIZING COMPOUNDS, INDUSTRIAL CARBON BLACK, HARDENER FOR PHENOLIC RESINS, SODIUM ALUMINIUM SILICATES, AUXILIARIES AND FILLING AND COATING AGENTS, COLLOIDS OBTAINED FROM RAW MATERIALS, USED AS THICKENER, STABILIZER AND JELLING AGENTS; CHEMICALS USED IN THE CONSTRUCTION INDUSTRY, NAMELY, FUMED AND PRECIPITATED SILICA, SILANES, POLYMER FOUNDATIONS, ADHESIVES, SOIL STABILIZERS, QUALITY IMPROVING ADDITIVES FOR CEMENT, LIME, GYPSUM, ANHYDRITE, REFRACTORY MASSES AND CERAMICS, ACRYLIC REACTIVE RESIN SYSTEMS FOR CONSTRUCTION USES, HAVING POWDER AND LIQUID COMPONENTS FOR USE IN PROTECTION, EMBEDDING, FORMING, BONDING RESTORATION AND REPAIR OF CONCRETE, WOOD, METAL OR PLASTIC MATERIALS, AND FORMING AND PRECASTING OBJECTS IN THE NATURE OF PRECAST POLYMER CONCRETE PARTS; UNPROCESSED ARTIFICIAL RESINS FOR GENERAL INDUSTRIAL USE; UNPROCESSED PLASTICS; FERTILIZERS, NAMELY, CALCIUM CYANAMIDE-SPECIALTIES, NITROGEN BASED FERTILIZERS ON A UREA BASIS IN COMBINATION WITH AMMONIUM NITRATE AND SULPHATE SALTS AND NITROGEN STABILIZED FERTILIZERS, AND MANURES; PLANT GROWTH REGULATORS FOR AGRICULTURAL USE; FLAME PROTECTION PREPARATIONS, NAMELY, FLAME RETARDANT COMPOSITIONS AND FIRE EXTINGUISHING COMPOSITIONS; METAL TEMPERING AND SOLDERING CHEMICALS; ENZYMES FOR INDUSTRIAL PURPOSES, NAMELY FOR SCIENTIFIC OR RESEARCH PURPOSES; ENZYME PREPARATIONS FOR USE IN THE ALCOHOL AND DETERGENT IN-

DUSTRIES; ODOR INHIBITORS FOR ORGANIC WASTE, NAMELY, ODOR ELIMINATING TABLETS COMPRISED OF MICRO-ORGANISMS AND ENZYMES TO BE DISSOLVED IN WATER AND USED TO DIGEST WASTE; SPECIALIZED HYDROGEN PEROXIDES FOR USE IN ODOR CONTROL IN THE RUBBER AND PLASTICS INDUSTRIES; TANNING SUBSTANCES, NAMELY, FOR USE IN THE MANUFACTURE OF LEATHER, CHEMICAL INGREDIENT FOR USE IN THE MANUFACTURE OF SELF-TANNING PREPARATIONS; INDUSTRIAL ADHESIVES; TECHNICAL GASES, NAMELY, NOBLE GASES AND GASES BEING RAW MATERIALS FOR INDUSTRIAL PURPOSES, CHEMICAL PURPOSES, CATALYTIC PURPOSES, FOR INSERTING, FOR DRYING AND GASES FOR FREEZING AGENTS, NAMELY, HELIUM, HYDROGEN, NITROGEN, OXYGEN, ARGON, NEON, KRYPTON, METHANE, ETHANE, CARBON MONOXIDE, CARBON DIOXIDE, PROPANE AND BUTANE.

ELEMENTS CORRECTED  
OWNER NAME

3,559,170. REG. 1-6-2009. ENCRYPTANET, INC. (CALIFORNIA CORPORATION) 1222 W. MALBORO AVENUE, ANAHEIM, CA, 92801, SN 78-959,091. FILED 8-23-2006. PRINCIPAL REGISTER.

# PAYCLOUD

THE MARK CONSISTS OF STANDARD CHARACTERS WITHOUT CLAIM TO ANY PARTICULAR FONT, STYLE, SIZE, OR COLOR.

INT. CL. 9/U.S. CLS. 21, 23, 26, 36 AND 38

FOR COMPUTER SOFTWARE, NAMELY, COMPUTER SOFTWARE FOR ACCESSING DIGITAL CONTENT SUCH AS ONLINE CONTENT; COMPUTER SOFTWARE FOR PROVIDING DIGITAL TECHNOLOGIES VIA TELECOMMUNICATIONS SYSTEMS, TELEPHONE, PDA, HAND-HELD COMPUTERS, CELLULAR PHONES, E-MAIL, THE INTERNET, COMPUTER NETWORK, OTHER COMMUNICATION DEVICES, ELECTRONIC COMMUNICATIONS NETWORKS, OR THE INTERNET; COMPUTER SOFTWARE FOR PROVIDING AN INTERACTIVE WEB SITE; COMPUTER SOFTWARE FOR PROVIDING ACCESS SOLUTIONS FOR DIGITAL CONTENT; COMPUTER SOFTWARE FOR MANAGING BANDWIDTH ALLOCATIONS IN TELECOMMUNICATIONS SERVICES AND FOR SENDING TELEGRAPHIC, CABLE AND SATELLITE TRANSMISSIONS; COMPUTER SOFTWARE FOR SENDING COMMUNICATIONS BY COMPUTER TERMINALS; COMPUTER SOFTWARE FOR FINANCIAL SERVICES, NAMELY, FOR MANAGING ELECTRONIC PAYMENT SERVICES; COMPUTER SOFTWARE FOR AUTHORIZING PAYMENT TRANSACTION SERVICES; COMPUTER SOFTWARE FOR TRANSMISSION OF TRANSACTION DATA, FINANCIAL DATA AND PAYMENT INFORMATION VIA TELECOMMUNICATION SYSTEMS, TELEPHONE, PDA, HAND-HELD COMPUTERS, CELLULAR PHONES, E-MAIL, THE INTERNET, COMPUTER NETWORK AND OTHER COMMUNICATION DEVICES; COMPUTER SOFTWARE FOR PROVIDING DIGITAL CERTIFICATES; COMPUTER HARDWARE; COMPUTER SOFTWARE AND COMPUTER HARDWARE FOR OBTAINING AND STORING INFORMATION FOR SECURE PROCESSING AND TRANSFERRING DATA OVER NETWORKS, FOR AUTHORIZATION AND AUTHENTICATION OF NETWORK USERS AND DATA AND FOR PAYMENT AND PREPAYMENT.

FIRST USE 3-1-2006; IN COMMERCE 3-1-2006.  
INT. CL. 36/U.S. CLS. 100, 101 AND 102

FOR PROVIDING AN INTERACTIVE WEB SITE FEATURING FINANCIAL INFORMATION; ELECTRONIC PAYMENT, NAMELY, ELECTRONIC PROCESSING AND TRANSMISSION OF BILL PAYMENT DATA; ELECTRONIC FUNDS TRANSFER BY TELECOMMUNICATIONS; FINANCIAL INFORMATION PROVIDED BY ELECTRONIC MEANS; PROVIDING ELECTRONIC PROCESSING OF CREDIT CARD TRANSACTIONS AND ELECTRONIC PAYMENTS VIA A GLOBAL COMPUTER NETWORK AND MOBILE PHONES; ELECTRONIC TRANSFERS OF MONEY; ELECTRONIC CREDIT CARD TRANSACTIONS; ELECTRONIC DEBIT TRANSACTIONS; ELECTRONIC COMMERCE PAYMENT SERVICES, NAMELY, ESTABLISHING FUNDED ACCOUNTS USED TO PURCHASE GOODS AND SERVICES ON THE INTERNET.

FIRST USE 3-1-2006; IN COMMERCE 3-1-2006.

INT. CL. 38/U.S. CLS. 100, 101 AND 104

FOR PROVIDING DIGITAL TECHNOLOGIES, NAMELY, ELECTRONIC TRANSMISSION OF DIGITAL TECHNOLOGY PACKETS VIA TELECOMMUNICATIONS SYSTEMS, TELEPHONE, PERSONAL DIGITAL ASSISTANTS, HAND-HELD COMPUTERS, CELLULAR PHONES, E-MAIL, THE INTERNET, COMPUTER NETWORKS, OTHER COMMUNICATION DEVICES, ELECTRONIC COMMUNICATIONS NETWORKS OR THE INTERNET; COMMUNICATION AND TRANSMISSION OF FINANCIAL DATA AND PAYMENT INFORMATION BY MEANS OF TELECOMMUNICATION SYSTEMS, TELEPHONE, PERSONAL DIGITAL ASSISTANTS, HAND-HELD COMPUTERS, CELLULAR PHONES, E-MAIL, THE INTERNET, COMPUTER NETWORKS AND OTHER COMMUNICATION DEVICES, TELECOMMUNICATIONS SERVICES IN THE NATURE OF ELECTRONIC MESSAGE TRANSMISSION, TELEGRAPHIC, CABLE RADIO AND SATELLITE TRANSMISSIONS, COMMUNICATIONS BY COMPUTER TERMINAL, PROVIDING ACCESS TO FINANCIAL DATABASES; ELECTRONIC TRANSMISSION OF TRANSACTION DATA VIA TELECOMMUNICATION SYSTEMS, TELEPHONE, PERSONAL DIGITAL ASSISTANTS, HAND-HELD COMPUTERS, CELLULAR PHONES, E-MAIL, THE INTERNET, COMPUTER NETWORKS AND OTHER COMMUNICATION DEVICES; COMMUNICATIONS BY MOBILE PHONE, COMMUNICATIONS VIA MULTINATIONAL TELECOMMUNICATION NETWORKS, COMMUNICATIONS VIA FIBER-OPTIC NETWORKS, DATA COMMUNICATION BY ELECTRONIC MAIL; INFORMATION TRANSMISSION VIA ELECTRONIC COMMUNICATIONS NETWORKS; AND TRANSMISSION OF INFORMATION BY ELECTRONIC COMMUNICATIONS NETWORKS.

FIRST USE 3-1-2006; IN COMMERCE 3-1-2006.

INT. CL. 45/U.S. CLS. 100 AND 101

FOR AUTHENTICATION, ISSUANCE AND VALIDATION OF DIGITAL CERTIFICATES; PROVIDING USER AUTHENTICATION SERVICES IN E-COMMERCE TRANSACTIONS; IDENTIFICATION VERIFICATION SERVICES, NAMELY, PROVIDING AUTHENTICATION OF PERSONAL IDENTIFICATION INFORMATION.

FIRST USE 3-1-2006; IN COMMERCE 3-1-2006.

ELEMENTS CORRECTED  
OWNER NAME  
OWNER ADDRESS

3,618,511. REG. 5-12-2009. MAGICJACK LP (DELAWARE LIMITED PARTNERSHIP) 5700 GEORGIA AVE., WEST PALM BEACH, FL, 33405, SN 77-469,374. FILED 5-8-2008. PRINCIPAL REGISTER.



The logo for magicJack features the word "magicJack" in a bold, lowercase, sans-serif font. A thick, black, curved arrow starts under the "i" in "magic" and points to the right, ending under the "k" in "Jack".

OWNER OF U.S. REG. NO. 3,446,818.  
INT. CL. 9/U.S. CLS. 21, 23, 26, 36 AND 38

FOR DOWNLOADABLE SOFTWARE USED TO ENABLE VOICE OVER INTERNET PROTOCOL (VOIP) COMMUNICATIONS; COMPUTER SOFTWARE FOR USE IN OPERATING DEVICES THAT ENABLE VOICE OVER INTERNET PROTOCOL (VOIP) COMMUNICATIONS; TELECOMMUNICATIONS EQUIPMENT, NAMELY ELECTRICAL CONNECTORS USED TO ENABLE VOICE COMMUNICATIONS OVER INTERNET PROTOCOL (IP) AND IP NETWORKS.

FIRST USE 3-7-2007; IN COMMERCE 5-31-2007.

INT. CL. 38/U.S. CLS. 100, 101 AND 104

FOR PROVIDING VOICE OVER INTERNET PROTOCOL (VOIP) COMMUNICATIONS SERVICES.

FIRST USE 3-7-2007; IN COMMERCE 5-31-2007.

ELEMENTS CORRECTED  
CITIZENSHIP

3,669,459. REG. 8-18-2009. LAUDA DR. R. WOBSEY GMBH & CO. KG (FED REP GERMANY GMBH & CO. KG) PFARRSTR. 41-43, 97922 LAUDA-KÖNIGSHOFEN, FED REP GERMANY., SN 79-013,297. FILED 10-28-2004. PRINCIPAL REGISTER.

# LAUDA

PRIORITY DATE OF 5-11-2004 IS CLAIMED.  
OWNER OF INTERNATIONAL REGISTRATION 0856574 DATED 10-28-2004, EXPIRES 10-28-2014.

OWNER OF U.S. REG. NO. 1,684,311.

LAUDA IS THE FIRST WORD OF "LAUDA-KÖNIGSHOFEN", THE NAME OF A TOWN IN GERMANY.  
SEC. 2(F).

INT. CL. 9/U.S. CLS. 21, 23, 26, 36 AND 38

FOR THERMOSTATS, NAMELY, HEATING THERMOSTATS, COOLING THERMOSTATS AND WATER BATHS, FOR USE IN LABORATORIES; PROCESS THERMOSTATS; AND MEASURING INSTRUMENTS FOR PHYSICAL VALUES, NAMELY, THERMOMETERS, DIGITAL THERMOMETERS, VISCOSITY MEASURING INSTRUMENTS AND TENSIMETERS.

FIRST USE ; IN COMMERCE .

ELEMENTS CORRECTED  
OWNER ADDRESS

3,681,443. REG. 9-8-2009. MSTATION AUDIO, LLC (MICHIGAN LIMITED LIABILITY COMPANY) 9040 TELSTAR AVENUE, #123, EL MONTE, CA, 91731, SN 77-977,640. FILED 12-10-2007. PRINCIPAL REGISTER.



THE MARK CONSISTS OF THE LETTER "M" IN A CIRCLE.

INT. CL. 9/U.S. CLS. 21, 23, 26, 36 AND 38

FOR AUDIO SPEAKERS; LOUD SPEAKERS; LOUD SPEAKERS AND STEREO SYSTEMS COMPRISED OF SPEAKERS, SPEAKERS USED ON DOCKING STATIONS FOR PORTABLE AUDIO DEVICES, NAMELY, MP3 PLAYERS, AND DOCKING STATIONS FOR USE WITH AUDIO SPEAKERS; ELECTRONIC AND OPTICAL COMMUNICATIONS INSTRUMENTS AND COMPONENTS, NAMELY, AUDIO SPEAKERS, CARRYING AND PROTECTIVE CASES FOR AUDIO DEVICES, BATTERY PACKS, NAMELY, BATTERIES WITH INTEGRATED DOCKING FOR MOBILE ELECTRONIC DEVICES; BATTERIES AND BATTERY CHARGERS FOR USE AS EXTERNAL POWER SOURCES WITH MOBILE CONSUMER ELECTRONIC PRODUCTS; ELECTRICAL CELLS AND BATTERIES, NAMELY, EXTERNAL POWER SOURCES WITH INTEGRATED HOUSING AND ELECTRICAL CONNECTOR; CELL PHONE BATTERY CHARGERS, NAMELY, EXTERNAL POWER SOURCES WITH INTEGRATED HOUSING AND ELECTRICAL CONNECTOR FOR MOBILE PHONES; AND MOBILE TELEPHONE BATTERIES, NAMELY, EXTERNAL BATTERY PACKS WITH INTEGRATED DOCKING FOR MOBILE TELEPHONES.

FIRST USE 11-30-2007; IN COMMERCE 11-30-2007.

ELEMENTS CORRECTED

OWNER NAME  
OWNER ADDRESS  
CITIZENSHIP  
ENTITY

3,681,444. REG. 9-8-2009. MSTATION AUDIO, LLC (MICHIGAN LIMITED LIABILITY COMPANY) 9040 TELSTAR AVENUE, #123, EL MONTE, CA, 91731, SN 77-977,641. FILED 12-10-2007. PRINCIPAL REGISTER.



THE MARK CONSISTS OF THE LETTER "M."  
INT. CL. 9/U.S. CLS. 21, 23, 26, 36 AND 38

FOR AUDIO SPEAKERS; LOUD SPEAKERS; LOUD SPEAKERS AND STEREO SYSTEMS COMPRISED OF SPEAKERS, SPEAKERS USED ON DOCKING STATIONS FOR PORTABLE AUDIO DEVICES, NAMELY, MP3 PLAYERS, AND DOCKING STATIONS FOR USE WITH AUDIO SPEAKERS; ELECTRONIC AND OPTICAL COMMUNICATIONS INSTRUMENTS AND COMPONENTS, NAMELY, AUDIO SPEAKERS, CARRYING AND PROTECTIVE CASES FOR AUDIO DEVICES, BATTERY PACKS, NAMELY, BATTERIES WITH INTEGRATED DOCKING FOR MOBILE ELECTRONIC DEVICES; BATTERIES AND BATTERY CHARGERS FOR USE AS EXTERNAL POWER SOURCES WITH MOBILE CONSUMER ELECTRONIC PRODUCTS; ELECTRICAL CELLS AND BATTERIES, NAMELY, EXTERNAL POWER SOURCES WITH INTEGRATED HOUSING AND ELECTRICAL CONNECTOR; CELL PHONE BATTERY CHARGERS, NAMELY, EXTERNAL POWER SOURCES WITH INTEGRATED HOUSING AND ELECTRICAL CONNECTOR FOR MOBILE PHONES; AND MOBILE TELEPHONE BATTERIES, NAMELY, EXTERNAL BATTERY PACKS WITH INTEGRATED DOCKING FOR MOBILE TELEPHONES.

FIRST USE 11-30-2007; IN COMMERCE 11-30-2007.

ELEMENTS CORRECTED

OWNER NAME  
OWNER ADDRESS  
CITIZENSHIP  
ENTITY

3,699,130. REG. 10-20-2009. PIAGGIO & C. S.P.A. (ITALY JOINT STOCK COMPANY) VIALE RINALDO PIAGGIO, 25, I-56025 PONTEDERA (PISA), ITALY., SN 79-060,886. FILED 6-18-2008. PRINCIPAL REGISTER.



PRIORITY DATE OF 3-25-2008 IS CLAIMED.  
OWNER OF INTERNATIONAL REGISTRATION 0982111 DATED 6-18-2008, EXPIRES 6-18-2018.

THE MARK CONSISTS OF THE WORDS "SPORTCITY ONE" IN SPECIAL SCRIPT.

INT. CL. 12/U.S. CLS. 19, 21, 23, 31, 35 AND 44

FOR VEHICLES FOR LOCOMOTION BY LAND, NAMELY, CYCLES, MOTORCYCLES, MOPEDS, SCOOTERS, MOTOR BICYCLES, BICYCLES, THREE AND FOUR WHEELED MOTOR VEHICLES WITH FLAT OR VAN BODIES, AUTOMOBILES, SMALL TRUCKS, VANS; MOTOR CAR BODIES, TRUCK BODIES, FRAMES AND CHASSIS FOR MOTOR CARS, TRUCKS, MOTORCYCLES AND BICYCLES, SUSPENSION SYSTEMS FOR SCOOTERS, MOTORCYCLES, MOPEDS, MOTOR BICYCLES, BICYCLES, THREE AND FOUR WHEELED MOTOR VEHICLES WITH FLAT OR VAN BODIES, AUTOMOBILES, SMALL TRUCKS, VANS; VEHICLE PARTS, NAMELY, SHOCK ABSORBERS, BRAKES, STEERING MECHANISMS; SEATS FOR MOTOR CARS AND TRUCKS, DIRECTIONAL SIGNALS FOR VEHICLES, SADDLES FOR BICYCLES AND MOTORCYCLES, ANTI-THEFT ALARMS FOR VEHICLES.

FIRST USE ; IN COMMERCE .

ELEMENTS CORRECTED  
\*DESCRIPTION OF MARK\*

3,724,705. REG. 12-15-2009. PRIORITY PUBLICATIONS INC. (MINNESOTA CORPORATION), DBA PRIORITY PUBLISHING MARKETING INTERACTIVE, 6700 FRANCE AVENUE SOUTH #300, MINNEAPOLIS, MN, 55435, SN 77-651,728. FILED 1-17-2009. PRINCIPAL REGISTER.



NO CLAIM IS MADE TO THE EXCLUSIVE RIGHT TO USE "PUBLISHING", "MARKETING", "INTERACTIVE", APART FROM THE MARK AS SHOWN.

THE COLOR(S) RED, BLACK, AND WHITE IS/ARE CLAIMED AS A FEATURE OF THE MARK.

THE MARK CONSISTS OF RED DIAMOND SHAPED SQUARE WITH WHITE ARROW THROUGH SHAPE SAME SIZE AS RED "PRIORITY" WORD; UNDERNEATH "PRIORITY" WORD ARE WORDS IN BLACK PUBLISHING MARKETING INTERACTIVE IN SMALLER CAPITAL LETTERS THAT FIT UNDERNEATH "PRIORITY".

INT. CL. 35/U.S. CLS. 100, 101 AND 102

FOR PUBLISHING OF ADVERTISING TEXTS; MARKETING CONSULTATION; AND MARKETING PLAN DEVELOPMENT.

FIRST USE 1-1-2008; IN COMMERCE 1-1-2008.

ELEMENTS CORRECTED  
OWNER NAME  
DBA/AKA

3,754,886. REG. 3-2-2010. HUSQVARNA AKTIEBOLAG (SWEDEN LIMITED LIABILITY COMPANY) DROTTNINGGATAN 2, SE-561 82 HUSKVARNA, SWEDEN., SN 79-066,070. FILED 9-1-2008. PRINCIPAL REGISTER.

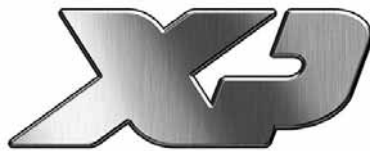

PRIORITY DATE OF 3-17-2008 IS CLAIMED.

OWNER OF INTERNATIONAL REGISTRATION 0995492 DATED 9-1-2008. EXPIRES 9-1-2018.

INT. CL. 4/U.S. CLS. 1, 6 AND 15

FOR OIL FOR TWO-STROKE AND FOUR-CYCLE ENGINES.

INT. CL. 7/U.S. CLS. 13, 19, 21, 23, 31, 34 AND 35

FOR MACHINE AND MACHINE TOOLS, NAMELY, CUTTING MACHINES; HANDHELD SAWS AS INTEGRAL COMPONENT PARTS OF CUTTING MACHINES; POWER OPERATED SAWS; CHAIN SAWS, POWER OPERATED SAWS, NAMELY, POLE SAWS AND CLEARING SAWS; HEDGE AND TREE TRIMMING MACHINES, POWER OPERATED HEDGE TRIMMERS, POWER CUTTERS, POWER OPERATED BRUSH CUTTERS; SAW BLADES AS INTEGRAL COMPONENT PARTS OF CUTTING MACHINES; LAWN MOWING MACHINES, RIDE-ON LAWN MOWERS, GARDEN TRACTORS, AERATORS, POWER OPERATED DETHATCHERS, POWER OPERATED CULTIVATORS, POWER OPERATED BLOWING AND SUCKING DEVICES, NAMELY, LEAF AND SNOW BLOWERS, AND GARDEN VACUUMS MACHINES; ACCESSORIES FOR THE AFOREMENTIONED GOODS, NAMELY, MACHINE TOOL HOLDERS, CASES SPECIALLY ADAPTED FOR THE AFOREMENTIONED GOODS; HARNESSSES; REPLACEMENT PARTS FOR THE AFOREMENTIONED GOODS.

ELEMENTS CORRECTED  
[GOODS/SERVICES]  
[INTERNATIONAL CLASS(ES)]

3,776,945. REG. 4-20-2010. BIOCARE LABS, INC. (ILLINOIS CORPORATION) 5202 W 70TH PL, BEDFORD PARK, IL, 60638, SN 77-694,834. FILED 3-19-2009. PRINCIPAL REGISTER.

# BIOCARE

THE MARK CONSISTS OF STANDARD CHARACTERS WITHOUT CLAIM TO ANY PARTICULAR FONT, STYLE, SIZE, OR COLOR.

INT. CL. 3/U.S. CLS. 1, 4, 6, 50, 51 AND 52

FOR HAIR CARE PREPARATIONS; NON-MEDICATED SKIN CARE PREPARATIONS.

FIRST USE 4-30-1991; IN COMMERCE 12-31-1991.

ELEMENTS CORRECTED  
DATE OF FIRST USE  
DATE OF FIRST USE IN COMMERCE

3,797,186. REG. 6-1-2010. UNISOURCE WORLDWIDE, INC. (DELAWARE CORPORATION) 6600 GOVERNORS LAKE PARKWAY, NORCROSS, GA, 30371, SN 77-704,563. FILED 4-1-2009. PRINCIPAL REGISTER.



OWNER OF U.S. REG. NOS. 3,325,554, 3,443,464 AND OTHERS.

NO CLAIM IS MADE TO THE EXCLUSIVE RIGHT TO USE ".COM", APART FROM THE MARK AS SHOWN.

THE COLOR(S) RED, BLACK, GRAY, AND WHITE IS/ARE CLAIMED AS A FEATURE OF THE MARK.

THE MARK CONSISTS OF RED UPPERCASE "U" WITH RED STRIPED SHADOW AND WHITE STRIPES; THE LITERAL ELEMENT "UNISOURCE" IN SOLID BLACK; THE LITERAL ELEMENT "DIRECT" IN BLACK, GRAY AND WHITE STRIPES, AND THE LITERAL ELEMENT ".COM" IN GRAY.

INT. CL. 35/U.S. CLS. 100, 101 AND 102

FOR ONLINE WHOLESALE DISTRIBUTORSHIP SERVICES IN THE FIELD OF PAPER AND INDUSTRIAL SUPPLIES, NAMELY, OFFICE AND STATIONERY PRODUCTS, MAINTENANCE AND CLEANING PREPARATIONS, FOOD SERVICE DISPOSABLES, SANITARY AND HEALTH CARE PRODUCTS, AND PACKAGING MATERIALS AND PACKAGING EQUIPMENT.

FIRST USE 4-2-2009; IN COMMERCE 4-2-2009.

ELEMENTS CORRECTED  
CITIZENSHIP

3,843,557. REG. 9-7-2010. PEEPOOPLE AB (SWEDEN CORPORATION) ALSNOGATAN 3, 116 41 STOCKHOLM, SWEDEN., SN 77-623,814. FILED 12-1-2008. PRINCIPAL REGISTER.

# PEEPOOPLE

THE MARK CONSISTS OF STANDARD CHARACTERS WITHOUT CLAIM TO ANY PARTICULAR FONT, STYLE, SIZE, OR COLOR.



PRIORITY CLAIMED UNDER SEC. 44(D) ON ERPN CMNTY TM OFC APPLICATION NO. 006952261, FILED 5-30-2008, REG. NO. 006952261, DATED 3-26-2009, EXPIRES 5-30-2018.

INT. CL. 5/U.S. CLS. 6, 18, 44, 46, 51 AND 52

FOR SANITARY PREPARATIONS FOR MEDICAL PURPOSES; SANITARY DISINFECTANTS FOR HYGIENE PURPOSES; MATERIALS FOR DRESSINGS, NAMELY, GAUZE, BANDAGES, MEDICAL ADHESIVE TAPES, MEDICAL PLASTERS; SANITARY TOWELS.

FIRST USE ; IN COMMERCE .

INT. CL. 16/U.S. CLS. 2, 5, 22, 23, 29, 37, 38 AND 50

FOR EDUCATIONAL PRINTED MATERIALS, NAMELY, BOOKS, FLASH CARDS, TRAINING MANUALS, INSTRUCTIONAL BOOKS, FOLDERS, BROCHURES, NEWSLETTERS AND MAGAZINES REGARDING HYGIENIC AND SANITARY PRODUCTS, SANITATION FACILITIES AND SINGLE-USE TOILETS.

FIRST USE ; IN COMMERCE .

INT. CL. 35/U.S. CLS. 100, 101 AND 102

FOR RETAIL STORE SERVICES FEATURING SANITARY PREPARATIONS FOR MEDICAL PURPOSES, SANITARY FLANNEL, SANITARY DISINFECTANTS FOR HYGIENE PURPOSES, MATERIALS FOR DRESSINGS, SANITARY TOWELS, PORTABLE TOILETS, SINGLE-USE TOILETS, TOILET SEATS, STERILE DISPOSABLE BAGS, TOILET [ GLOWS ], \* GLOVES \* COVERS FOR TOILET SEATS, TOILETRIES, EDUCATIONAL MATERIALS; PROVIDING CONSUMER PRODUCT INFORMATION IN CONNECTION WITH RETAIL STORE SERVICES IN THE FIELD OF SANITARY PREPARATIONS FOR MEDICAL PURPOSES, SANITARY FLANNEL, SANITARY DISINFECTANTS FOR HYGIENE PURPOSES, MATERIALS FOR DRESSINGS, SANITARY TOWELS, SANITARY NAPKINS, SANITARY WET WIPES, PORTABLE TOILETS, SINGLE-USE TOILETS, TOILET SEATS, STERILE DISPOSABLE BAGS, TOILET [ GLOWS ] \* GLOVES \*, COVERS FOR TOILET SEATS, TOILETRIES.

FIRST USE ; IN COMMERCE .

INT. CL. 41/U.S. CLS. 100, 101 AND 107

FOR EDUCATIONAL SERVICES, NAMELY, PROVIDING CLASSES, SEMINARS AND WORKSHOPS IN THE FIELD OF HYGIENIC AND SANITARY PRODUCTS, PERSONAL HYGIENE, HEALTH CARE, SANITATION FACILITIES AND SINGLE-USE TOILETS, AND DISTRIBUTION OF COURSE MATERIAL IN CONNECTION THEREWITH; PROVIDING ONLINE NON-DOWNLOADABLE EDUCATIONAL MATERIALS, NAMELY, INSTRUCTIONAL BOOKS, FOLDERS, BROCHURES, TRAINING MANUALS, VIDEOS, TEXT BOOKS, NEWSLETTERS AND MAGAZINES REGARDING HYGIENIC AND SANITARY PRODUCTS, SANITATION FACILITIES AND SINGLE-USE TOILETS.

FIRST USE ; IN COMMERCE .

INT. CL. 44/U.S. CLS. 100 AND 101

FOR HEALTH CARE SERVICES, NAMELY, HYGIENE CARE; RENTAL OF SANITATION FACILITIES AND SINGLE-USE TOILETS.

FIRST USE ; IN COMMERCE .

ELEMENTS CORRECTED  
GOODS/SERVICES

3,845,651. REG. 9-7-2010. BSW BERLEBURGER SCHAUM-STOFFWERK GMBH (FED REP GERMANY LIMITED LIABILITY COMPANY) AM HILGENACKER 24, BAD BERLEBURG, FED REP GERMANY, 57310, SN 77-399,615. FILED 2-18-2008. PRINCIPAL REGISTER.

# RECOFLEX

THE MARK CONSISTS OF STANDARD CHARACTERS WITHOUT CLAIM TO ANY PARTICULAR FONT, STYLE, SIZE, OR COLOR.

OWNER OF ERPN CMNTY TM OFC REG. NO. 003753035, DATED 9-10-2007, EXPIRES 4-13-2014.

INT. CL. 19/U.S. CLS. 1, 12, 33 AND 50

FOR BUILDING MATERIALS OF WOOD, CORK, GRANULES AND ELASTOMERS, NAMELY, ELASTIC CHIPBOARD; NON-METAL FLOORS AND WALL CLADDINGS; AND FLEXIBLE CHIPBOARDS.

FIRST USE 7-28-2009; IN COMMERCE 7-28-2009.

ELEMENTS CORRECTED  
GOODS/SERVICES

3,854,617. REG. 9-28-2010. IVIVI HEALTH SCIENCES, LLC (DELAWARE LIMITED LIABILITY COMPANY) 588 SUTTER STREET, #231, SAN FRANCISCO, CA, 94102, SN 77-750,250. FILED 6-2-2009. PRINCIPAL REGISTER.

# Assisi

THE MARK CONSISTS OF STANDARD CHARACTERS WITHOUT CLAIM TO ANY PARTICULAR FONT, STYLE, SIZE, OR COLOR.

INT. CL. 10/U.S. CLS. 26, 39 AND 44

FOR HIGH FREQUENCY ELECTROMAGNETIC THERAPY APPARATUS.

FIRST USE 6-4-2009; IN COMMERCE 6-4-2009.

ELEMENTS CORRECTED  
\*OWNER NAME\*  
\*OWNER ADDRESS\*  
\*CITIZENSHIP\*  
\*ENTITY\*

3,855,685. REG. 10-5-2010. ROBERT ROTHSCHILD FARM, LLC (DELAWARE LIMITED LIABILITY COMPANY) P.O. BOX 767, URBANA, OH, 43078, SN 77-816,435. FILED 8-31-2009. PRINCIPAL REGISTER.

## ROBERT ROTHSCHILD FARM

THE MARK CONSISTS OF STANDARD CHARACTERS WITHOUT CLAIM TO ANY PARTICULAR FONT, STYLE, SIZE, OR COLOR.

OWNER OF U.S. REG. NO. 3,634,280.

NO CLAIM IS MADE TO THE EXCLUSIVE RIGHT TO USE "FARM", APART FROM THE MARK AS SHOWN.

THE NAME(S), PORTRAIT(S), AND/OR SIGNATURE(S) SHOWN IN THE MARK IDENTIFIES "ROBERT ROTHSCHILD", WHOSE CONSENT(S) TO REGISTER IS MADE OF RECORD.

INT. CL. 29/U.S. CL. 46

FOR DIPS, FRUIT-BASED SPREADS, VEGETABLE-BASED SPREADS, CHEESE SPREADS, SOUPS, CURD, JELLIES AND JAMS, FRUIT PRESERVES, GIFT BASKETS PRIMARILY FEATURING COMBINATIONS OF DIPS, FRUIT-BASED SPREADS, VEGETABLE-BASED SPREADS, CHEESE SPREADS, SOUPS, CURD, JELLIES AND JAMS AND FRUIT PRESERVES.

FIRST USE 0-0-1984; IN COMMERCE 0-0-1984.

INT. CL. 30/U.S. CL. 46

FOR GRAIN-BASED SNACK FOODS, PRETZELS, TORTILLA CHIPS, CRACKERS, SPICE RUBS, SALSA, MUSTARD, SAUCES, MARINADES, PASTA SAUCE, SALAD DRESSING, TOPPING SYRUP, CHUTNEY, MIXES FOR BAKERY GOODS, GIFT BASKETS PRIMARILY FEATURING COMBINATIONS OF GRAIN-BASED SNACK FOODS, PRETZELS, TORTILLA CHIPS, CRACKERS, SPICE RUBS, SALSA, MUSTARD, SAUCES, MARINADES, PASTA SAUCE, SALAD DRESSING, TOPPING SYRUP, CHUTNEY OR MIXES FOR BAKERY GOODS.

FIRST USE 0-0-1984; IN COMMERCE 0-0-1984.

ELEMENTS CORRECTED  
OWNER NAME



3,861,379. REG. 10-12-2010. MARS, INCORPORATED (DELAWARE CORPORATION) 6885 ELM STREET, MCLEAN, VA, 22101, SN 77-510,126. FILED 6-27-2008. PRINCIPAL REGISTER.

## DOGS RULE

THE MARK CONSISTS OF STANDARD CHARACTERS WITHOUT CLAIM TO ANY PARTICULAR FONT, STYLE, SIZE, OR COLOR.

OWNER OF U.S. REG. NOS. 2,565,746, 2,969,041 AND 3,291,605.

INT. CL. 31/U.S. CLS. 1 AND 46

FOR PET FOOD.

FIRST USE 9-0-2006; IN COMMERCE 9-0-2006.

ELEMENTS CORRECTED  
DATE OF FIRST USE



3,862,683. REG. 10-19-2010. BOARD & BATTEN INTERNATIONAL INC. (CAYMAN ISLANDS COMPANY) C/O INT'L MANAGEMENT SERVICES LIMITED, HARBOUR CENTRE, 4TH FLOOR, NORTH CHURCH, GEORGETOWN, CAYMAN ISLANDS., SN 77-804,563. FILED 8-14-2009. PRINCIPAL REGISTER.

## FLEXRSTEP

THE MARK CONSISTS OF STANDARD CHARACTERS WITHOUT CLAIM TO ANY PARTICULAR FONT, STYLE, SIZE, OR COLOR.

PRIORITY CLAIMED UNDER SEC. 44(D) ON NEW ZEALAND APPLICATION NO. 808870, FILED 7-2-2009, REG. NO. 808870, DATED 7-2-2009, EXPIRES 7-2-2019.

INT. CL. 20/U.S. CLS. 2, 13, 22, 25, 32 AND 50

FOR LADDERS OF WOOD OR PLASTIC, PARTS AND FITTINGS FOR THE AFORESAID GOODS.

FIRST USE ; IN COMMERCE .

ELEMENTS CORRECTED  
OWNER NAME

3,862,987. REG. 10-19-2010. BEACH COVE RESORT, INC. (SOUTH CAROLINA CORPORATION) 4800 S. OCEAN BLVD., NORTH MYRTLE BEACH, SC, 29582, SN 77-863,552. FILED 11-3-2009. PRINCIPAL REGISTER.

## BEACH COVE

THE MARK CONSISTS OF STANDARD CHARACTERS WITHOUT CLAIM TO ANY PARTICULAR FONT, STYLE, SIZE, OR COLOR.

NO CLAIM IS MADE TO THE EXCLUSIVE RIGHT TO USE "BEACH", APART FROM THE MARK AS SHOWN.

INT. CL. 43/U.S. CLS. 100 AND 101

FOR HOTEL, BAR AND RESTAURANT SERVICE.

FIRST USE 9-3-1985; IN COMMERCE 9-3-1985.

ELEMENTS CORRECTED  
OWNER ADDRESS



3,874,505. REG. 11-9-2010. ADVANCE AUTO INNOVATIONS, LLC (VIRGINIA LIMITED LIABILITY COMPANY) 5008 AIRPORT ROAD, ROANOKE, VA, 24012, SN 77-787,035. FILED 7-22-2009. PRINCIPAL REGISTER.

## AUTOCRAFT

THE MARK CONSISTS OF STANDARD CHARACTERS WITHOUT CLAIM TO ANY PARTICULAR FONT, STYLE, SIZE, OR COLOR.

OWNER OF U.S. REG. NOS. 1,622,118, 2,640,809 AND 3,144,780.

INT. CL. 6/U.S. CLS. 2, 12, 13, 14, 23, 25 AND 50

FOR LOAD CONTROL MATERIALS, NAMELY, UNIVERSAL ANCHOR POINTS OF METAL, RATCHET TIEDOWNS OF METAL, CAMBUCKLE TIEDOWNS OF METAL.

FIRST USE 6-0-2010; IN COMMERCE 6-0-2010.

INT. CL. 22/U.S. CLS. 1, 2, 7, 19, 22, 42 AND 50

FOR LOAD CONTROL MATERIALS, NAMELY, VEHICLE TOWING ROPE, TOWING STRAPS, BUNGEE CORDS, TARPULINS, TARPULIN STRAPS AND NON-METAL LASHING STRAPS WITH BUCKLES.

FIRST USE 6-0-2010; IN COMMERCE 6-0-2010.

ELEMENTS CORRECTED  
GOODS/SERVICES



3,875,198. REG. 11-16-2010. BAKERS FOOTWEAR GROUP INC. (MISSOURI CORPORATION) 2815 SCOTT AVENUE, ST. LOUIS, MO, 63103, SN 75-449,163. FILED 3-12-1998. PRINCIPAL REGISTER.

## BAKERS

REGISTRATION LIMITED TO THE AREA COMPRISING THE ENTIRE UNITED STATES EXCEPT PUERTO RICO AND THE UNITED STATES VIRGIN ISLANDS PURSUANT TO CONCURRENT USE PROCEEDING NOS. 94002018 AND 94002253. CONCURRENT REGISTRATION APPLICATION SERIAL NOS. 76385015, 76385016, 76385017, 76385018, 76385019, 76641405 AND 76641406, OWNED BY NOVUS, INC. OWNER OF U.S. REG. NO. 719,778.

INT. CL. 25/U.S. CLS. 22 AND 39

FOR CLOTHING, NAMELY, HATS, BELTS, SOCKS, SHOES, SCARVES, TIGHTS, SHOE INSERTS, NAMELY, CUSHIONED HEEL INSERTS, AND NON-SLIP PADS FOR APPLICATION TO THE SOLES OF SHOES.

FIRST USE 12-31-1997; IN COMMERCE 12-31-1997.

ELEMENTS CORRECTED

OWNER NAME  
OWNER ADDRESS  
[CITIZENSHIP]

3,877,780. REG. 11-16-2010. ADVANCE AUTO INNOVATIONS, LLC (VIRGINIA LIMITED LIABILITY COMPANY) 5008 AIRPORT ROAD, ROANOKE, VA, 24012, SN 77-786,658. FILED 7-22-2009. PRINCIPAL REGISTER.

## AUTOCRAFT

THE MARK CONSISTS OF STANDARD CHARACTERS WITHOUT CLAIM TO ANY PARTICULAR FONT, STYLE, SIZE, OR COLOR.

OWNER OF U.S. REG. NOS. 1,622,118, 2,640,809 AND 3,144,780.

INT. CL. 12/U.S. CLS. 19, 21, 23, 31, 35 AND 44

FOR SEMI-FITTED COVERS FOR VEHICLES AND BOATS; AUTOMOBILE SEAT CUSHIONS; STEERING WHEEL COVERS.

FIRST USE 8-0-2010; IN COMMERCE 8-0-2010.

ELEMENTS CORRECTED

GOODS/SERVICES

3,879,392. REG. 11-23-2010. CHINA JILIN FOREST INDUSTRY GROUP CO., LTD. (CHINA CORPORATION) NO. 4036, RENMIN STREET, CHANGCHUN; JILIN PROVINCE, CHINA., SN 79-082,725. FILED 3-30-2010. PRINCIPAL REGISTER.



**Chambitionsure**

森工

PRIORITY DATE OF 2-22-2010 IS CLAIMED.  
OWNER OF INTERNATIONAL REGISTRATION 1039187  
DATED 3-30-2010, EXPIRES 3-30-2020.

THE MARK CONSISTS OF A DEVICE, AN INVENTED WORD "CHAMPTIONSURE" AND TWO CHINESE CHARACTERS; THE TRANSLITERATION OF THE CHINESE CHARACTERS IS "SEN GONG"; "SEN" MEANS "FOREST", "GONG" MEANS "LABOR"; THE TWO CHINESE CHARACTERS AS A WHOLE HAVE NO MEANING.

THE ENGLISH TRANSLATION OF THE FOREIGN WORD(S) IN THE MARK IS: THE TWO CHINESE CHARACTERS ARE TRANSLITERATED AS "SEN GONG". "SEN" MEANS "FOREST", "GONG" MEANS "LABOR"; THE TWO CHINESE CHARACTERS AS A WHOLE HAVE NO MEANING.

THE TRANSLITERATION OF THE NON-LATIN CHARACTERS IN THE MARK IS: THE FIRST CHINESE CHARACTER CONTAINED IN THE MARK IS TRANSLITERATED AS "SEN", THE SECOND CHINESE CHARACTER IS TRANSLITERATED AS "GONG".

INT. CL. 32/U.S. CLS. 45, 46 AND 48

FOR MINERAL WATER; AERATED WATER; VEGETABLE JUICES, BEING BEVERAGES; SODA WATER [; BEER ].

FIRST USE ; IN COMMERCE .

ELEMENTS CORRECTED

GOODS/SERVICES  
ENTITY

3,880,173. REG. 11-23-2010. GEOGREEN BIOFUELS, INC. (DELAWARE CORPORATION) 6011 MALBURG WAY, VERNON, CA, 90058, SN 77-079,905. FILED 1-10-2007. PRINCIPAL REGISTER.

## SAVING THE PLANET, ONE FRENCH FRY AT A TIME!

THE MARK CONSISTS OF STANDARD CHARACTERS WITHOUT CLAIM TO ANY PARTICULAR FONT, STYLE, SIZE, OR COLOR.

INT. CL. 40/U.S. CLS. 100, 103 AND 106

FOR CONVERTING WASTE VEGETABLE OIL INTO BIODIESEL FUEL.

FIRST USE 3-6-2009; IN COMMERCE 3-6-2009.

ELEMENTS CORRECTED

OWNER NAME

3,882,159. REG. 11-30-2010. MCCABE, SUSAN (UNITED STATES INDIVIDUAL) 2867 RANCHO CORTES, CARLSBAD, CA, 92009, SN 77-765,901. FILED 6-23-2009. PRINCIPAL REGISTER.

## JOY OF LIVING

THE MARK CONSISTS OF STANDARD CHARACTERS WITHOUT CLAIM TO ANY PARTICULAR FONT, STYLE, SIZE, OR COLOR.

INT. CL. 16/U.S. CLS. 2, 5, 22, 23, 29, 37, 38 AND 50

FOR A SERIES OF BOOKS IN THE FIELD OF INSPIRATION, SELF ESTEEM AND LIFESTYLE \*, SPECIFICALLY EXCLUDING COOKBOOKS AND RECIPE BOOKS \*.

FIRST USE 4-25-2009; IN COMMERCE 5-20-2009.

ELEMENTS AMENDED  
GOODS/SERVICES

3,882,662. REG. 11-30-2010. STRÖCK-BROT GMBH (AUSTRIA GESELLSCHAFT MIT BESCHRÄNKTER HAF-TUNG (GMBH)) JOHANN-STRÖCK-GASSE 1, INDUSTRIESTRASSE 68, A-1220 WIEN, AUSTRIA., SN 79-075,641. FILED 9-11-2009. PRINCIPAL REGISTER.



PRIORITY DATE OF 9-11-2009 IS CLAIMED.  
OWNER OF INTERNATIONAL REGISTRATION 1020279 DATED 9-11-2009, EXPIRES 9-11-2019.

NO CLAIM IS MADE TO THE EXCLUSIVE RIGHT TO USE "ORGANIC", APART FROM THE MARK AS SHOWN. THE COLOR(S) YELLOW, BROWN, GREEN, AND WHITE IS/ARE CLAIMED AS A FEATURE OF THE MARK.

THE MARK CONSISTS OF A GREEN OUTLINE OF A SEMICIRCLE WITH A WHITE INTERIOR. ON THE WHITE INTERIOR IS A YELLOW SEMICIRCLE WITH THE WORD "STROCK" IN A BROWN AND YELLOW STYLIZED FONT WITH A DESIGN OF WHEAT IN BROWN AND YELLOW ABOVE THE LETTER "O" IN "STROCK". BENEATH THE WORD IS A GREEN OBLONG SHAPE CONTAINING THE WORD "ORGANIC" IN WHITE.

THE WORDING "STROCK" HAS NO MEANING IN A FOREIGN LANGUAGE.

INT. CL. 16/U.S. CLS. 2, 5, 22, 23, 29, 37, 38 AND 50  
FOR [ PHOTOGRAPHS; PRINTERS' TYPE; ] PRINTING BLOCKS.

FIRST USE ; IN COMMERCE .

INT. CL. 30/U.S. CL. 46

FOR [ COFFEE, TEA, COCOA, ] FLOUR AND PREPARATIONS MADE FROM CEREALS, [ NAMELY, BREAKFAST CEREALS, PROCESSED CEREALS, AND CEREAL BASED SNACK FOODS; ] BREAD, PASTRY AND CONFECTIONERY, [ NAMELY, FROZEN CONFECTIONERY, FRUIT JELLIES, AND PASTILLES; ] YEAST, BAKING-POWDER [; ALL OF THE FOREGOING MADE WHOLLY OR SUBSTANTIALLY OF ORGANIC INGREDIENTS ] .

FIRST USE ; IN COMMERCE .  
INT. CL. 35/U.S. CLS. 100, 101 AND 102

FOR ADVERTISING SERVICES.

FIRST USE ; IN COMMERCE .

INT. CL. 39/U.S. CLS. 100 AND 105

FOR PACKAGING OF GOODS FOR TRANSPORTATION; STORAGE OF GOODS.

FIRST USE ; IN COMMERCE .

ELEMENTS CORRECTED  
GOODS/SERVICES

3,885,598. REG. 12-7-2010. CHARMANTE S.R.L. (ITALY LIMITED LIABILITY COMPANY) VIA BASSA DI CASALMORO, 3, ASOLA (MANTOVA), ITALY., SN 79-077,406. FILED 7-13-2009. PRINCIPAL REGISTER.

PRIORITY DATE OF 6-5-2009 IS CLAIMED.  
OWNER OF INTERNATIONAL REGISTRATION 1025137 DATED 7-13-2009, EXPIRES 7-13-2019.

THE TRADEMARK CONSISTS OF THE WORD "PERLITTA" WRITTEN IN PARTICULAR LOWERCASE LETTERS EXCEPT FOR THE LETTER "P", WHICH IS A CAPITAL; THE WORD "PERLITTA" IS CHARACTERIZED WITH GRAPHIC ELEMENTS, SUCH AS A RIBBON ON THE LEFT SIDE OF "P", AND TWO STYLIZED CROWNS, ONE ON THE "P" AND THE OTHER ON THE "I".

INT. CL. 9/U.S. CLS. 21, 23, 26, 36 AND 38

FOR EYE GLASSES, SUNGLASSES.

INT. CL. 25/U.S. CLS. 22 AND 39

FOR CLOTHING, UNDERCLOTHING, FOOTWEAR AND HEADWEAR, NAMELY, KNITWEAR IN THE NATURE OF KNITTED SHIRTS, KNITTED UNDERWEAR, TROUSERS, SHORTS, SUITS, SKIRTS, PULL-OVERS, SHIRTS, SWEATERS, JACKETS, T-SHIRTS, SPORTSWEAR, NAMELY, JERSEYS, SHORTS, SWEAT PANTS, SWIMSUITS, BEACH WRAPS, GLOVES, BELTS, MONEY BELTS, SCARVES, FOULARDS, TIES, STOCKINGS, PAJAMAS, PANTIES, BODIES, NAMELY, BODY SHIRTS, BODY SUITS, BODY SHAPERS, BODY STOCKINGS, BRASSIERES, SHOES, SPORTIVE SHOES, BEACH SHOES, SANDALS, HATS, ALL THE AFOREMENTIONED GOODS FOR MEN, WOMEN AND CHILDREN.  
FIRST USE ; IN COMMERCE .

ELEMENTS CORRECTED  
[GOODS/SERVICES]  
[INTERNATIONAL CLASS(ES)]

3,889,246. REG. 12-14-2010. YAMAHA MOTOR CO., LTD. (JAPAN CORPORATION) 2500 SHINGAI, IWATA-SHI; SHIZUOKA-KEN 438-8501, JAPAN., SN 79-068,526. FILED 12-24-2008. PRINCIPAL REGISTER.

OWNER OF INTERNATIONAL REGISTRATION 1001956 DATED 12-24-2008, EXPIRES 12-24-2018.

OWNER OF U.S. REG. NOS. 688,208, 3,555,631 AND OTHERS.

THE MARK CONSISTS OF THE WORDING "YAMAHA" IN STYLIZED FONT.

INT. CL. 4/U.S. CLS. 1, 6 AND 15

FOR LUBRICATING OILS; MINERAL OILS AND GREASES FOR INDUSTRIAL PURPOSES NOT FOR FUEL; NON-MINERAL OILS AND GREASES FOR INDUSTRIAL PURPOSES NOT FOR FUEL; SOLID FUELS; LIQUID FUELS; GASEOUS FUELS; FUELS; WAXES; GREASE FOR SHOES AND BOOTS; SOLID LUBRICANTS USED FOR ENGINES, GEARS, TRANSMISSIONS, AND BEARING; LEATHER PRESERVING OIL AND GREASE; LAMP WICKS; CANDLES.

FIRST USE ; IN COMMERCE .  
INT. CL. 7/U.S. CLS. 13, 19, 21, 23, 31, 34 AND 35

FOR OUTBOARD MOTORS FOR BOATS AND SHIPS AND THEIR STRUCTURAL PARTS; DRIVING MOTORS FOR BOATS AND SHIPS AND THEIR STRUCTURAL PARTS; MARINE ENGINES FOR BOATS AND SHIPS AND THEIR STRUCTURAL PARTS; MULTI-PURPOSE ENGINES AND THEIR STRUCTURAL PARTS NOT FOR LAND VEHICLES; STRUCTURAL PARTS FOR ENGINES NOT FOR LAND VEHICLES; ELECTRICITY GENERATORS AND THEIR STRUCTURAL PARTS; WATER PUMPS AND THEIR STRUCTURAL PARTS FOR ENGINES NOT FOR LAND VEHICLES; SNOWPLOWS AND THEIR STRUCTURAL PARTS; INDUSTRIAL ROBOTS AND THEIR STRUCTURAL PARTS; SURFACE MOUNTERS AND THEIR STRUCTURAL PARTS, NAMELY, MACHINES USED FOR MANUFACTURING ELECTRONIC CIRCUITS AND THEIR STRUCTURAL PARTS; METALWORKING MACHINES AND TOOLS, NAMELY, INDUSTRIAL ROBOTS; PUNCHING PRESSES, SHAPING MACHINES; METAL SAWING MACHINES; GRINDING MACHINES; PERFORATING MACHINES; CUTTING MACHINES; LATHES; SLOTTING MACHINES; BORING MACHINES; THREADING MACHINES; NUT-TAPPING MACHINES; GEAR CUTTING

AND FINISHING MACHINES; MILLING MACHINES; BROACHING MACHINES; PLANING MACHINES; HONING MACHINES; DRILLING MACHINES; LAPING MACHINES; ROLLING MILLS; TUBING MILLS; WIRE EXTRUDING MACHINES; WIRE DRAWING MACHINES; MECHANICAL PRESSES; HYDRAULIC PRESSES; SHEARING MACHINES; FORGING MACHINES; BENDING MACHINES; OIL HYDRAULIC PRESSES; WIRE FORMING MACHINES; GAS WELDING MACHINES; OXY-ACETYLENE WELDING AND CUTTING MACHINES; ELECTRIC WELDING MACHINES; PNEUMATIC DRILLS; PNEUMATIC HAMMERS; GRINDERS; ELECTRIC SANDERS; ELECTRIC DRILLS; ELECTRIC HAMMERS; ELECTRIC SCREWDRIVERS; ELECTRIC NUT RUNNERS; POWER-OPERATED BUFFERS; POWER-OPERATED POLISHERS; POWER-DRIVEN WRENCHES; POWER-OPERATED MACHINES USED FOR CUTTING METALS; GEAR CUTTERS; TAPS; CHASERS; POWER DRILL BITS; THREAD MILLING CUTTERS; TURNING POINT TOOLS, NAMELY, METALWORKING MACHINE TOOLS; BROACHES; MILLING CUTTERS; POWER TOOLS, NAMELY, REAMERS; CEMENTED CARBIDE TIPS; CEMENTED CARBIDE CUTTING TOOLS; ANTI-CORROSIVE CEMENTED CARBIDE CUTTING TOOLS; ANTI-ABRASIVE CEMENTED CARBIDE CUTTING TOOLS; DIAMOND TOOLS, NAMELY, MILLING CUTTERS, DIAMOND-POINTED METAL-CUTTING TOOLS, WEAR-RESISTANT DIAMOND-POINTED METAL-CUTTING TOOLS; FORGING MOULDS AND DIES FOR METAL-FORMING FOR USE WITH MACHINE TOOLS, FORGING MOULDS; PRESS DIES FOR METAL FORMING; MINING MACHINES AND THEIR STRUCTURAL PARTS, NAMELY, FRONT END LOADERS, FRONT LOADERS, BUCKET LOADERS, PAYLOADERS, SCOOP LOADERS, SHOVEL LOADERS, SKIP LOADERS, WHEEL LOADERS; COAL CUTTING MACHINES; OIL WELL PUMP MACHINES; ROCK DRILLS; WELL DRILLING MACHINES; MINING DRILL SHARPENERS; MINE BORERS; COAL MOVING MACHINES, NAMELY, LOADERS; TRUCK MILLS; COAL PLOUGHS; CONSTRUCTION MACHINES AND THEIR STRUCTURAL PARTS, NAMELY, EXCAVATING MACHINES, SLACK CONVEYOR LINES, TRUCK CRANES, POWER SHOVELS; ROOTERS, NAMELY, MACHINES USED FOR REMOVING TREE ROOTS; FOUNDATION WORK MACHINES, EARTH AUGERS, PILE-DRIVERS, PILE-EXTRACTORS, HYDRAULIC GROUT PUMPS, GROUND SURFACE FINISHING AND COMPACTING MACHINES, EARTH MOVING MACHINES, NAMELY, GRADERS; EARTH MOVING MACHINES, NAMELY, SCRAPERS; TAMPING MACHINES; BULLDOZERS, RAMMERS, NAMELY, GASOLINE POWERED MACHINES FOR COMPACTING SOIL; ROAD ROLLERS, NAMELY, GROUND SURFACE FINISHING AND COMPACTING MACHINES; CONCRETE CONSTRUCTION MACHINES, CONCRETE PLACING MACHINES, CONCRETE VIBRATORS, CONCRETE PAVING MACHINES, CONCRETE MIXERS, BATCHER PLANTS, NAMELY, MACHINES USED FOR MIXING CONCRETE; ASPHALT PAVING MACHINES, ASPHALT DISTRIBUTORS, NAMELY, MACHINES USED FOR SPREADING ASPHALT; ASPHALT FINISHERS, NAMELY, GROUND SURFACE FINISHING AND COMPACTING MACHINES; ASPHALT PLANTS, NAMELY, MACHINES USED FOR MIXING ASPHALT; ASPHALT MIXERS, DREDGING MACHINES, MUD DREDGING MACHINES, LOADING-UNLOADING MACHINES; CHEMICAL PROCESSING MACHINES; TEXTILE MACHINES AND THEIR STRUCTURAL PARTS, NAMELY, SILK YARN REELING MACHINES, COCOON DRYING MACHINES, SILK YARN TESTING MACHINES, SILK YARN BUNDLING MACHINES, SILK YARN REELING MACHINES, COCOON BOILING MACHINES, COCOON-WASTE TREATING MACHINES, CHEMICAL FIBER DRYING MACHINES, STAPLE FIBER CUTTING MACHINES, CHEMICAL FIBER PURIFYING MACHINES, CHEMICAL FIBER SPINNING MACHINES, YARN SINGEING MACHINES, YARN WINDING MACHINES, YARN CARDING MACHINES, YARN REELING MACHINES, FIBER BLOWING AND SCUTCHING MACHINES, YARN SLIVERING AND COMBING MACHINES, SPINNING FRAMES, NAMELY, MACHINES USED FOR MANUFACTURING YARN; ROVING MACHINES, CARDING MACHINES, YARN TWISTING MACHINES, YARN DRAWING FRAMES, NAMELY, MACHINES USED FOR DRAWING OUT YARN; AUTOMATIC LOOMS, POWER WEAVING LOOMS, POWER LOOMS, FISH-NET HAULING MACHINES, EMBROIDERY MA-

CHINES, ROPE MAKING MACHINES, BRAIDING MACHINES, NAMELY, MACHINES USED FOR BRAIDING YARN; HOSIERY LOOMS, LACE MAKING MACHINES AND THEIR STRUCTURAL PARTS, FELT MILLING MACHINES, FELT CARDING MACHINES, TEXTILE CALENDERING MACHINES, RAISING MACHINES, NAMELY, MACHINES USED FOR ALTERING THE TEXTURE OF FABRIC; SPRAY DAMPING MACHINES, YARN SINGEING MACHINES, WET DECATIZING MACHINES; DIP-DYEING MACHINES, TEXTILE SCUTCHING MACHINES, TEXTILE MAKING MACHINES, NAMELY, TEXTILE MANUFACTURING MACHINES; TEXTILE WASHING MACHINES, PRINTING MACHINES; TEXTILE TENTERING MACHINES, PALMER FELT CALENDERING MACHINES; CONTINUOUS SCOURING AND BLEACHING MACHINES, ROTARY PRESSES; FOOD OR BEVERAGE PROCESSING MACHINES AND THEIR STRUCTURAL PARTS, NAMELY, CEREAL PROCESSING MACHINES AND THEIR STRUCTURAL PARTS, BARLEY SPLITTING MACHINES, CONFECTIONERY MAKING MACHINES, BAKERY MACHINES, NAMELY, MACHINES USED FOR MANUFACTURING BAKED GOODS; FLOUR MILLING MACHINES, RICE OR BARLEY POLISHING MACHINES, NOODLE MAKING MACHINES, BARLEY SPLITTING MACHINES, BREWING OR FERMENTING MACHINES AND THEIR STRUCTURAL PARTS, NAMELY, MACHINES USED FOR BREWING AND FERMENTING ALCOHOLIC BEVERAGES AND THEIR STRUCTURAL PARTS; BREWING MACHINES AND THEIR STRUCTURAL PARTS, NAMELY, MACHINES USED FOR BREWING ALCOHOLIC BEVERAGES AND THEIR STRUCTURAL PARTS; SOY SAUCE MAKING MACHINES AND THEIR STRUCTURAL PARTS, MISO MAKING MACHINES AND THEIR STRUCTURAL PARTS, ICE CREAM MAKING MACHINES, MILK HOMOGENIZING MACHINES, CHEESE MAKING MACHINES, BUTTER MACHINES, POWDERED MILK MAKING MACHINES, CONDENSED MILK MAKING MACHINES, MEAT PROCESSING MACHINES AND THEIR STRUCTURAL PARTS, NAMELY, ELECTRIC MEAT GRINDERS AND THEIR STRUCTURAL PARTS; SAUSAGE MACHINES, ELECTRIC MEAT MINCERS, FISHERY PRODUCT PROCESSING MACHINES AND THEIR STRUCTURAL PARTS, NAMELY, FISH PASTE MAKING MACHINES AND THEIR STRUCTURAL PARTS; MACHINES FOR FLAKING DRIED FISH MEAT; EDIBLE KELP PROCESSING MACHINES, FISH PASTE MAKING MACHINES, CANNING MACHINES, ROOT SLICING MACHINES, SODA-POP MAKING MACHINES, TEA MAKING MACHINES, OIL PROCESSING MACHINES, NAMELY, MACHINES USED FOR MANUFACTURING COOKING OIL; BOTTLING MACHINES, MINERAL WATER MAKING MACHINES, VEGETABLE GRATING MACHINES; LUMBERING, WOODWORKING, OR VENEER OR PLYWOOD MAKING MACHINES AND THEIR STRUCTURAL PARTS, NAMELY, LUMBERING MACHINES AND THEIR STRUCTURAL PARTS IN THE NATURE OF WOOD MILLING MACHINES, LUMBERING BAND SAWS, CHAIN SAWS, SAWING MACHINES, SAW-TOOTH SETTING MACHINES, CIRCULAR SAWS, WOODWORKING MACHINES AND THEIR STRUCTURAL PARTS, NAMELY, SANDING MACHINES AND THEIR STRUCTURAL PARTS; WOODEN-CLOG SHAPING MACHINES AND THEIR STRUCTURAL PARTS, SANDING MACHINES, WOOD PLANING MACHINES, WOOD LATHES, WOOD MILLING MACHINES, WOOD SAWING MACHINES, WOODWORKING SAW-TOOTH SETTING MACHINES, WOOD VENEER MANUFACTURING MACHINES AND THEIR STRUCTURAL PARTS; PLYWOOD FINISHING MACHINES, PLYWOOD DRYING MACHINES, PLYWOOD PRESSES, PLYWOOD CLIPPING MACHINES, PLYWOOD JOINTING MACHINES, PLYWOOD GLUING MACHINES; PULP MAKING, PAPER MAKING OR PAPER-WORKING MACHINES AND THEIR STRUCTURAL PARTS, NAMELY, MACHINES FOR MAKING PULP, WOOD GRINDING MACHINES, WOOD CHIPPING MACHINES, BARKING MACHINES, PULPING MACHINES, WOOD BEATING MACHINES, PULP REFINING MACHINES, PAPER MAKING MACHINES AND THEIR STRUCTURAL PARTS, PAPER CALENDERING MACHINES, PAPER COATING MACHINES, PAPER CUTTING MACHINES, MACHINES FOR MAKING COMPONENT PARTS FOR PAPER DRIERS, MACHINES FOR MAKING COMPONENT PARTS FOR PRINTING PRESSES, PAPER REELING MACHINES, MACHINES FOR MAKING COMPONENT PARTS OF WIRE ROPE; MACHINES FOR MANUFACTURING PAPER AND

THEIR STRUCTURAL PARTS, CORRUGATED PAPERBOARD MAKING MACHINES, PAPER BOX MAKING MACHINES, PAPER BAG MAKING MACHINES; PRINTING AND BOOKBINDING MACHINES FOR COMMERCIAL OR INDUSTRIAL USE; PACKAGING AND WRAPPING MACHINES; PLASTIC PROCESSING MACHINES AND THEIR STRUCTURAL PARTS, NAMELY, COMPRESSION MOULDING MACHINES, EXTRUSION MOULDING MACHINES, INJECTION MOULDING MACHINES; SEMICONDUCTOR MANUFACTURING MACHINES; RUBBER-GOODS MANUFACTURING MACHINES AND THEIR STRUCTURAL PARTS, NAMELY, RUBBER VULCANIZING MACHINES, RUBBER MIXING MACHINES, MACHINES FOR CUTTING AND POLISHING STONE; NON-ELECTRIC PRIME MOVERS, NOT FOR LAND VEHICLES, NAMELY, INTERNAL COMBUSTION ENGINES NOT FOR LAND VEHICLES, GASOLINE ENGINES NOT FOR LAND VEHICLES, DIESEL ENGINES NOT FOR LAND VEHICLES, KEROSENE ENGINES NOT FOR LAND VEHICLES, STEAM ENGINES NOT FOR LAND VEHICLES; STEAM MARINE ENGINES; STEAM ENGINES NOT FOR LAND VEHICLES; MOTORS NOT FOR LAND VEHICLES, TURBINES NOT FOR LAND VEHICLES, JET ENGINES NOT FOR LAND VEHICLES, TURBOJET ENGINES NOT FOR LAND VEHICLES, TURBOPROP ENGINES NOT FOR LAND VEHICLES, RAMJET ENGINES NOT FOR LAND VEHICLES, ROCKET ENGINES NOT FOR LAND VEHICLES, COMPRESSED AIR ENGINES NOT FOR LAND VEHICLES, GAS TURBINES NOT FOR LAND VEHICLES, AIR TURBINES NOT FOR LAND VEHICLES, STEAM TURBINES NOT FOR LAND VEHICLES, HYDRAULIC TURBINES NOT FOR LAND VEHICLES, COMPRESSED AIR ENGINES NOT FOR LAND VEHICLES; PARTS FOR NON-ELECTRIC PRIME MOVERS FOR LAND VEHICLES, NAMELY, VEHICLE ENGINE PARTS IN THE NATURE OF PISTONS, DISTRIBUTOR CAPS, OIL TANKS, PUSH RODS, ROCKER ARMS, INTERCOOLERS, CYLINDER CASES, CYLINDERS, CYLINDER HEADS, CRANKSHAFTS, CRANKS, CONNECTING RODS, GEARS, CAM SHAFTS, INTAKE VALVES, EXHAUST VALVES, VALVE SPRINGS, PISTON RINGS; CYLINDERS FOR ENGINES FOR LAND VEHICLES; CRANKSHAFTS FOR ENGINES FOR LAND VEHICLES; WIND MILLS; PNEUMATIC OR HYDRAULIC MACHINES AND INSTRUMENTS, NAMELY, WATER MILLS, WIND MILLS, HYDRAULIC TURBINES; CULTIVATING MACHINES AND IMPLEMENTS, NAMELY, POWER OPERATED CULTIVATORS; HARVESTING MACHINES AND IMPLEMENTS IN THE NATURE OF AGRICULTURAL MACHINES, NAMELY, HARVESTERS; FODDER PRESSES; FODDER CUTTING MACHINES; FODDER MIXING MACHINES; CAKE-FODDER CRUSHING MACHINES; FILTERS FOR MACHINES FOR MANUFACTURING MILK; MILKING MACHINES; CHICK BROODERS INCUBATORS FOR EGGS; SERICULTURAL MACHINES AND IMPLEMENTS, NAMELY, MULBERRY LEAF CHOPPING MACHINES, MACHINES USED FOR SELECTING THE HIGHEST QUALITY SILKWORM EGGS, SILKWORM EGG WASHING MACHINES, MACHINES USED FOR DISCRIMINATING THE SEX OF SILKWORMS; FISHING MACHINES AND INSTRUMENTS, NAMELY, NET HAULING MACHINES, TRAWL WINCHES, LINE HAULERS; SEWING MACHINES; SHOE MAKING MACHINES; LEATHER TANNING MACHINES; TOBACCO PROCESSING MACHINES; ADHESIVE TAPE DISPENSING MACHINES; AUTOMATIC STAMPING MACHINES; STARTERS FOR MOTORS AND ENGINES; AC MOTORS AND DC MOTORS, NAMELY, ELECTRIC MOTORS FOR MACHINES AND THEIR STRUCTURAL PARTS; AC GENERATORS; DC GENERATORS; MECHANICAL PARKING SYSTEMS, NAMELY, POWER-OPERATED LIFTS FOR MOVING, PARKING, AND STORING LAND VEHICLES; LAWNMOWERS; REPAIRING AND FIXING MACHINES FOR LAND VEHICLES, NAMELY, POWERED TIRE CHANGER MACHINES FOR LAND VEHICLES, POWER JACKS, CAR LIFTS; ELECTRIC WASHING MACHINES FOR INDUSTRIAL PURPOSES; DISH WASHING MACHINES FOR INDUSTRIAL PURPOSES; ELECTRIC WAX-POLISHING MACHINES FOR INDUSTRIAL PURPOSES; VACUUM CLEANERS FOR INDUSTRIAL PURPOSES; DISH WASHING MACHINES FOR HOUSEHOLD PURPOSES; ELECTRIC WAX-POLISHING MACHINES FOR HOUSEHOLD PURPOSES; WASHING MACHINES FOR HOUSEHOLD PURPOSES; VACUUM CLEANERS FOR HOUSEHOLD PURPOSES; ELECTRIC FOOD BLENDERS FOR HOUSEHOLD PURPOSES; DYNAMO BRUSHES; ELEC-

TRICALLY OPERATED CURTAIN DRAWERS; POWER-OPERATED POTTERS' WHEELS; PAINTING MACHINES; VEHICLE WASHING INSTALLATIONS; WASTE COMPACTING MACHINES; WASTE CRUSHING MACHINES; MACHINE PARTS, NAMELY, SHAFTS, AXLES AND SPINDLES NOT FOR LAND VEHICLES; MACHINE PARTS, NAMELY, SHAFT COUPLINGS NOT FOR LAND VEHICLES; MACHINE PARTS, NAMELY, BEARINGS NOT FOR LAND VEHICLES; POWER TRANSMISSIONS AND GEARING FOR MACHINES; SHOCK ABSORBERS FOR MACHINES; SPIRAL SPRINGS NOT FOR LAND VEHICLES BEING PARTS OF MACHINES, LAMINATED LEAF-SPRINGS BEING PARTS OF MACHINES; BRAKES FOR MACHINES; VALVES FOR MACHINES; INTEGRATED CIRCUITS MANUFACTURING MACHINES AND THEIR STRUCTURAL PARTS; CLOTHES DRYING MACHINES FOR INDUSTRIAL PURPOSES; POWER-OPERATED SPRAYERS FOR DISINFECTANTS; INSECTICIDES AND DEODORANTS NOT FOR AGRICULTURAL PURPOSES.

FIRST USE ; IN COMMERCE .

INT. CL. 12/U.S. CLS. 19, 21, 23, 31, 35 AND 44

FOR MOTORCYCLES; SCOOTERS; ELECTRIC SCOOTERS; BICYCLES; ELECTRIC BICYCLES; ELECTRIC ASSISTING BICYCLES; ALL TERRAIN VEHICLES; SNOWMOBILES; MOTORIZED GOLF CARTS; RACING GO CARTS; WHEELCHAIRS; ELECTRIC ASSISTING WHEELCHAIRS; SHIPS AND BOATS; PERSONAL WATERCRAFTS, NAMELY, SINGLE AND MULTIPLE PASSENGER RECREATIONAL JET BOATS AND STRUCTURAL PARTS THEREFOR; UNMANNED HELICOPTERS FOR INDUSTRIAL USE; STRUCTURAL PARTS FOR ALL OF THE PRECEDING GOODS; ENGINES FOR LAND VEHICLES; VESSELS AND THEIR STRUCTURAL PARTS; AIR-CUSHION VEHICLES; AIRCRAFT AND THEIR STRUCTURAL PARTS; RAILWAY ROLLING STOCK AND THEIR STRUCTURAL PARTS; AUTOMOBILES AND THEIR STRUCTURAL PARTS; TWO-WHEELED MOTOR VEHICLES; BICYCLES AND THEIR STRUCTURAL PARTS; BABY CARRIAGES; RICKSHAWS; SLEDS FOR TRANSPORTING INDUSTRIAL EQUIPMENT; WHEELBARROWS; CARTS; HORSE DRAWN CARRIAGES; BICYCLE TRAILERS (RIYAKAH); WHEELCHAIRS; MINE-CAR PUSHERS; MINE-CAR PULLERS; TRACTORS; NON-ELECTRIC PRIME MOVERS FOR LAND VEHICLES, NAMELY, INTERNAL COMBUSTION ENGINES FOR LAND VEHICLES, GASOLINE ENGINES FOR LAND VEHICLES, DIESEL ENGINES FOR LAND VEHICLES, KEROSENE ENGINES FOR LAND VEHICLES, STEAM ENGINES FOR LAND VEHICLES, STEAM MARINE ENGINES FOR LAND VEHICLES, STEAM LAND ENGINES FOR LAND VEHICLES, MOTORS FOR LAND VEHICLES, TURBINES FOR LAND VEHICLES, JET ENGINES FOR LAND VEHICLES, TURBOJET ENGINES FOR LAND VEHICLES, TURBOPROP ENGINES FOR LAND VEHICLES, RAMJET ENGINES FOR LAND VEHICLES, ROCKET ENGINES FOR LAND VEHICLES, COMPRESSED AIR ENGINES FOR LAND VEHICLES, GAS TURBINES FOR LAND VEHICLES, AIR TURBINES FOR LAND VEHICLES, STEAM TURBINES FOR LAND VEHICLES, HYDRAULIC TURBINES FOR LAND VEHICLES; MACHINE PARTS, NAMELY, SHAFTS, AXLES AND SPINDLES FOR LAND VEHICLES; BEARINGS FOR LAND VEHICLES; STRUCTURAL COMPONENTS OF LAND VEHICLES USED FOR CONNECTING PARTS OF VEHICLE FRAMES; POWER TRANSMISSIONS AND GEARINGS FOR LAND VEHICLES; SHOCK ABSORBERS FOR LAND VEHICLES; SHOCK ABSORBING SPIRAL SPRINGS FOR LAND VEHICLES; BRAKES FOR LAND VEHICLES; AC MOTORS AND DC MOTORS FOR LAND VEHICLES; ADHESIVE RUBBER PATCHES FOR REPAIRING TUBES OR TIRES; ANTI-THEFT ALARMS FOR VEHICLES; PARACHUTES.

FIRST USE ; IN COMMERCE .

ELEMENTS CORRECTED  
[GOODS/SERVICES]  
[INTERNATIONAL CLASS(ES)]

3,891,744. REG. 12-21-2010. NINTENDO OF AMERICA INC. (WASHINGTON CORPORATION) 4600 150TH AVENUE NE, REDMOND, WA, 98052, SN 77-583,798. FILED 10-2-2008. PRINCIPAL REGISTER.

3,903,069. REG. 1-11-2011. CAMP BOW WOW DISTRIBUTION LLC (COLORADO LIMITED LIABILITY COMPANY) 1877 BROADWAY, SUITE 101, 1877 BROADWAY, BOULDER, CO, 80302, SN 77-980,428. FILED 11-19-2009. PRINCIPAL REGISTER.

## CLUB NINTENDO

THE MARK CONSISTS OF STANDARD CHARACTERS WITHOUT CLAIM TO ANY PARTICULAR FONT, STYLE, SIZE, OR COLOR.

PRIORITY CLAIMED UNDER SEC. 44(D) ON JAPAN APPLICATION NO. 2008-080082, FILED 10-1-2008, REG. NO. 5229090, DATED 5-1-2009, EXPIRES 5-1-2019.

OWNER OF U.S. REG. NOS. 1,213,822, 1,628,966 AND OTHERS.

INT. CL. 18/U.S. CLS. 1, 2, 3, 22 AND 41

FOR ALL PURPOSE SPORTS BAGS AND LUGGAGE; METAL HARDWARE FOR CARRYING CASES; NAMELY, HANDBAG FRAMES AND PURSE FRAMES; CARRYING CASES, UMBRELLAS AND THEIR PARTS; LEATHER, NAMELY, LEATHER BAGS; FUR, NAMELY, FUR BAGS; BABY BACKPACKS; ATHLETIC BAGS, BACKPACKS, BEACH BAGS, BOOK BAGS, BOSTON BAGS, CARRY-ON BAGS, COSMETIC BAGS SOLD EMPTY, DIAPER BAGS, DUFFEL BAGS, FANNY PACKS, GARMENT BAGS FOR TRAVEL, GYM BAGS, HANDBAGS, LEATHER BAGS FOR MERCHANDISE PACKAGING, LUGGAGE, MESH SHOPPING BAGS, OVERNIGHT BAGS, PURSES, SATCHELS, SCHOOL BAGS, SHAVING BAGS SOLD EMPTY, SHOE BAGS FOR TRAVEL, SHOULDER BAGS, SOUVENIR BAGS, SUITCASES, TOTE BAGS, TRAVEL BAGS AND WAIST PACKS; CLOTHING FOR ANIMALS; CHAMOIS LEATHER, NAMELY, CHAMOIS LEATHER BAGS; POUCHES, NAMELY, DRAWSTRING POUCHES, UMBRELLAS AND THEIR PARTS; WALKING STICKS; NOT FITTED VANITY CASES.

FIRST USE ; IN COMMERCE .

ELEMENTS CORRECTED  
GOODS/SERVICES  
OWNER ADDRESS

3,894,472. REG. 12-21-2010. JERRY HICKS (UNITED STATES INDIVIDUAL) 28800 OLD FREDERICKSBURG ROAD, BOERNE, TX, 78015, AND ESTHER HICKS (UNITED STATES INDIVIDUAL) 28800 OLD FREDERICKSBURG ROAD, BOERNE, TX, 78015, SN 77-630,315. FILED 12-10-2008. PRINCIPAL REGISTER.

## ABRAHAM-HICKS LAW OF ATTRACTION

THE MARK CONSISTS OF STANDARD CHARACTERS WITHOUT CLAIM TO ANY PARTICULAR FONT, STYLE, SIZE, OR COLOR.

OWNER OF U.S. REG. NO. 3,211,215.

INT. CL. 9/U.S. CLS. 21, 23, 26, 36 AND 38

FOR PRERECORDED CDS, CASSETTES, VIDEOS AND DVDS IN THE FIELD OF INSPIRATION AND SELF ESTEEM.

FIRST USE 7-31-2010; IN COMMERCE 7-31-2010.

ELEMENTS CORRECTED  
CITIZENSHIP

## WOOF 'N WASH

THE MARK CONSISTS OF STANDARD CHARACTERS WITHOUT CLAIM TO ANY PARTICULAR FONT, STYLE, SIZE, OR COLOR.

NO CLAIM IS MADE TO THE EXCLUSIVE RIGHT TO USE "WASH", APART FROM THE MARK AS SHOWN.

INT. CL. 36/U.S. CLS. 100, 101 AND 102

FOR CHARITABLE FUND RAISING .

FIRST USE 9-18-2009; IN COMMERCE 9-18-2009.

ELEMENTS CORRECTED  
OWNER NAME

3,904,150. REG. 1-11-2011. JONESHEIRS, INC. (GEORGIA CORPORATION) 1201 W. PEACHTREE STREET, ATLANTA, GA, 303093424, SN 85-050,165. FILED 5-28-2010. PRINCIPAL REGISTER.

*Bobby Jones*

OWNER OF U.S. REG. NOS. 1,643,722, 3,420,002 AND OTHERS.

THE NAME "BOBBY JONES" DOES NOT IDENTIFY A LIVING INDIVIDUAL.

THE MARK CONSISTS OF THE WORDS "BOBBY JONES" WRITTEN IN STYLIZED FORM.

INT. CL. 25/U.S. CLS. 22 AND 39

FOR SHIRTS, SWEATERS, SHORTS, PANTS, SKIRTS, JACKETS, PULLOVERS, SWEATSHIRTS, VESTS, AND CLOTHING BELTS.

FIRST USE 10-27-1988; IN COMMERCE 10-27-1988.

ELEMENTS AMENDED  
MARK

3,915,755. REG. 2-8-2011. WI, INC. (COLORADO CORPORATION) STE N, 96 INVERNESS DRIVE E, ENGLEWOOD, CO, 80112, SN 77-891,670. FILED 12-11-2009. PRINCIPAL REGISTER.

*Wi*

THE MARK CONSISTS OF STANDARD CHARACTERS WITHOUT CLAIM TO ANY PARTICULAR FONT, STYLE, SIZE, OR COLOR.

INT. CL. 42/U.S. CLS. 100 AND 101

FOR DESIGN, ENGINEERING, RESEARCH, DEVELOPMENT, AND TESTING OF NEW PRODUCTS FOR OTHERS IN THE MEDICAL FIELD.  
FIRST USE 8-31-2001; IN COMMERCE 8-31-2001.

ELEMENTS CORRECTED  
CITIZENSHIP  
MARK

3,916,132. REG. 2-8-2011. SMOVEY GMBH (AUSTRIA PRIVATE LIMITED COMPANY) IM STADTGUT A1, A-4400 STEYR, AUSTRIA., SN 79-071,527. FILED 3-2-2009. PRINCIPAL REGISTER.



PRIORITY DATE OF 2-12-2009 IS CLAIMED.  
OWNER OF INTERNATIONAL REGISTRATION 1009333 DATED 3-2-2009, EXPIRES 3-2-2019.

THE COLOR(S) LIGHT GREEN AND BLACK IS/ARE CLAIMED AS A FEATURE OF THE MARK.

THE MARK CONSISTS OF THE WORD "SMOVEY" IN LIGHT GREEN STYLIZED FONT. THERE ARE THREE LIGHT GREEN CURVED LINES ABOVE THE TOP LEFT SIDE OF THE LETTER "S" AND THREE LIGHT GREEN CURVED LINES BELOW THE BOTTOM RIGHT SIDE OF THE LETTER "Y". THE LETTER "O" IS COMPRISED OF TWO INTERLOCKING, OVERLAPPING CIRCLES. THERE IS A BLACK RECTANGLE POSITIONED ON THE TOP OF THE BOTTOM CIRCLE AND A BLACK RECTANGLE POSITIONED ON THE BOTTOM PORTION OF THE TOP CIRCLE.

THE WORDING "SMOVEY" HAS NO MEANING IN A FOREIGN LANGUAGE.

INT. CL. 16/U.S. CLS. 2, 5, 22, 23, 29, 37, 38 AND 50

FOR PAPER, CARDBOARD AND GOODS MADE FROM THESE MATERIALS, NOT INCLUDED IN OTHER CLASSES, NAMELY, SCHOOL SUPPLIES IN THE NATURE OF NOTEBOOK PAPER, WRAPPING PAPER, PAPER NOTEBOOKS, FOLDERS, PENS, BALL-POINT PENS, DRAWING RULERS, DRAFTING RULERS, BOOK BINDINGS, FILE FOLDERS; GIFT BAGS, PAPER BAGS, PAPER GARBAGE BAGS, GROCERY BAGS, BAGS OF PAPER AND PLASTICS FOR PACKAGING, STICKERS, BOOKS IN THE NATURE OF ADDRESS BOOKS, AUTOGRAPH BOOKS, COMIC BOOKS, CHILDREN'S BOOKS, BOOKS IN THE FIELD OF SPORTS, GYMNASICS, HEALTH AND NUTRITION; GREETING CARDS; INSTRUCTIONAL MANUALS FOR SPORTING EQUIPMENT; INSTRUCTIONAL MANUALS TO ACCOMPANY VIDEO RECORDINGS ON THE USE OF SPORTING EQUIPMENT; CALENDARS, MAGAZINES FEATURING SPORTS EQUIPMENT, GYMNASICS, STAYS AT HEALTH RESORTS AND REHABILITATION CENTERS AND MEDICAL PRACTICES; POSTERS, POSTCARDS, PAMPHLETS, BROCHURES, NEWSLETTERS, JOURNALS AND MAGAZINES IN THE FIELD OF SPORTS, SPORTS EQUIPMENT AND GYMNASICS, STAYS AT HEALTH RESORTS AND REHABILITATION CENTERS AND MEDICAL PRACTICES; NEWSPAPERS .

INT. CL. 17/U.S. CLS. 1, 5, 12, 13, 35 AND 50

FOR FLEXIBLE TUBES, NOT OF METAL, NAMELY, FLEXIBLE PLASTIC TUBES, FLEXIBLE RUBBER TUBES; PLASTICS IN EXTRUDED FORM FOR USE IN MANUFACTURE; FLEXIBLE PIPES, NOT OF METAL.

FIRST USE ; IN COMMERCE .  
INT. CL. 25/U.S. CLS. 22 AND 39

FOR CLOTHING, NAMELY, SUITS, BATHING CAPS, BATH SANDALS, BATH SLIPPERS, SHOWER CAPS, MONEY BELTS, CLOTHING FOR GYMNASICS IN THE NATURE OF GYM SUITS, GYM SHORTS, GYM PANTS, LEOTARDS, GYM TROUSERS, GYM T-SHIRTS, GYMNASICS SHOES, SLIPPERS, JUMPERS, SHIRT YOKES, SHIRTS, SLIPS, JACKETS, JERSEYS, STUFF JACKETS, HEADGEAR FOR WEAR IN THE NATURE OF HATS, CAPS AND BERETS, UNDERWEAR, SWEAT-ABSORBENT UNDERWEAR CLOTHING, PULLOVERS, WATERPROOF CLOTHING IN THE NATURE OF WATERPROOF FOOTWEAR, WETSUITS, WATER-PROOF JACKETS AND PANTS FOR SKIING AND SNOWBOARDING, JACKETS AND PANTS FOR OUTDOOR GYMNASICS AND SPORTS, SOCKS, SPORTS SHOES, HEADBANDS, TIGHTS, SWEATERS, T-SHIRTS, PANTS.  
FIRST USE ; IN COMMERCE .

INT. CL. 28/U.S. CLS. 22, 23, 38 AND 50

FOR GAMES AND PLAYTHINGS, NAMELY, TOYS IN THE NATURE OF DOLLS, ACTION FIGURES, DOG TOYS, SPORT EQUIPMENT, NAMELY, BALLS FOR GAMES, BALLS FOR GYMNASICS, DUMB-BELLS AND GYMNASIC RINGS; SPORTING ARTICLES NOT INCLUDED IN OTHER CLASSES, NAMELY, BODY-BUILDING APPARATUS, APPLIANCES FOR GYMNASICS IN THE NATURE OF GYMNASIC APPARATUS, GYMNASICS HORIZONTAL BARS, GYMNASICS TRAINING STOOLS, IN-LINE ROLLER SKATES, ROLLER SKATES.

INT. CL. 32/U.S. CLS. 45, 46 AND 48

FOR MINERAL AND AERATED WATERS AND OTHER NON-ALCOHOLIC DRINKS, NAMELY, VEGETABLE JUICES, ISOTONIC BEVERAGES; FRUIT DRINKS AND FRUIT JUICES.

INT. CL. 35/U.S. CLS. 100, 101 AND 102

FOR ADVERTISING; BUSINESS MANAGEMENT; BUSINESS ADMINISTRATION.

INT. CL. 39/U.S. CLS. 100 AND 105

FOR TRAVEL ARRANGEMENT, NAMELY, ESCORTING OF TRAVELERS AND ARRANGING OF TOURS.  
FIRST USE ; IN COMMERCE .

INT. CL. 41/U.S. CLS. 100, 101 AND 107

FOR EDUCATION INFORMATION; PUBLICATION OF BOOKS; PUBLICATION OF ELECTRONIC BOOKS AND JOURNALS ONLINE IN THE FIELD OF SPORTS, SPORTS EQUIPMENT, GYMNASICS AND STAYS AT HEALTH RESORTS, REHABILITATION CENTERS AND MEDICAL PRACTICES; PROVIDING OF TRAINING, NAMELY, TEACHING, CORRESPONDENCE COURSES, ARRANGING AND CONDUCTING OF EDUCATIONAL CONFERENCES, ARRANGING AND CONDUCTING OF EDUCATIONAL CONGRESSES, EDUCATIONAL EXAMINATION, DEMONSTRATION OF PRACTICAL TRAINING AND ARRANGING AND CONDUCTING OF SEMINARS IN THE FIELD OF GYMNASICS, SPORTS, HEALTH AND NUTRITION; ENTERTAINMENT, NAMELY, ARRANGING AND CONDUCTING OF ENTERTAINMENT WORKSHOPS IN THE FIELD OF GYMNASIC, SPORTS, HEALTH AND NUTRITION; VIDEO FILM PRODUCTION; SPORTING AND CULTURAL ACTIVITIES, NAMELY, ORGANIZATION OF EXHIBITIONS FOR CULTURAL OR EDUCATIONAL PURPOSES, PROVIDING SPORTS FACILITIES, HOLIDAY CAMP SERVICES, PROVIDING RECREATION FACILITIES, HEALTH CLUB SERVICES IN THE NATURE OF PROVIDING INSTRUCTION AND EQUIPMENT IN THE FIELD OF PHYSICAL EXERCISE; GYMNASICS INSTRUCTION; RENTAL OF SPORTS EQUIPMENT, EXCEPT VEHICLES; SPORTS CAMP SERVICES.

INT. CL. 45/U.S. CLS. 100 AND 101

FOR PERSONAL AND SOCIAL SERVICES RENDERED BY OTHERS TO MEET THE NEEDS OF INDIVIDUALS, NAMELY, LEGAL SERVICES FOR LICENSING OF COMPUTER SOFTWARE AND LICENSING OF INTELLECTUAL PROPERTY.  
FIRST USE ; IN COMMERCE .

ELEMENTS CORRECTED  
[GOODS/SERVICES]  
[INTERNATIONAL CLASS(ES)]



3,916,311. REG. 2-8-2011. SOVMESTNOE PREDPRIYATIE ZAKRYTOE AKTIONERNOE OBCHTCHESTVO "MILAVITSA" (BELARUS CORPORATION) OUL. NOVIVILENSKAYA 28, BY-220053 MINSK, BELARUS., SN 79-081,935. FILED 3-4-2010. PRINCIPAL REGISTER.



OWNER OF INTERNATIONAL REGISTRATION 0815898 DATED 9-15-2003, EXPIRES 9-15-2013.

THE COLOR(S) CRIMSON, WHITE IS/ARE CLAIMED AS A FEATURE OF THE MARK.

THE MARK CONSISTS OF THE WORD "MILAVITSA " IN WHITE WITH A CRIMSON BACKGROUND. THE LETTER "V" IN "VITSA" IS CAPITALIZED AND A STAR APPEARS ABOVE THE LETTER "I".

INT. CL. 10/U.S. CLS. 26, 39 AND 44

FOR MATERNITY SUPPORT BELTS FOR MEDICAL PURPOSES, ABDOMINAL CORSETS FOR MEDICAL PURPOSES.

INT. CL. 25/U.S. CLS. 22 AND 39

FOR CLOTHING, NAMELY, LINGERIE, BODY SHIRTS FOR WOMEN, BODICES, BLOUSES FOR WOMEN, BRA TOPS BEING SHIRTS FOR WOMEN HAVING BUILT-IN BRAS, BUSTIERS, CORSELETS, CORSELET PANTIES BEING PANTIES INCORPORATING A HALF-HEIGHT GIRDLE, CORSETS, HALF-HEIGHT CORSETS, NIGHTGOWNS, CAMISOLES, SWIMSUITS FOR WOMEN, BIKINIS, FITTED SWIMMING COSTUMES WITH BRA CUPS, UNDERSHIRTS FOR WOMEN, BOXER BRIEFS FOR WOMEN, BOXER SHORTS FOR WOMEN, PAREOS, PEIGNOIRS, GARTERS, SUSPENDER BELTS, GIRDLES, SHIRTS, BLOUSES, T-SHIRTS, PANTIES FOR WOMEN, SHAPEWEAR, NAMELY, PANTY-STYLE GIRDLES, LOW-WAISTLINE PANTIES, SWIMWEAR BEING PANTY-STYLE SWIM TRUNKS FOR WOMEN, TUNICS FOR WOMEN, BEACH COVERUPS, SKIRTS; BRASSIERES, INCLUDING BREAST-FEEDING BRASSIERES; CORSETRY ARTICLES, NAMELY, PANTY GIRDLES; PANTIES FOR PREGNANT WOMEN; BEACH AND SWIMWEAR; UNDERWEAR; BRASSIERES AND SWIMMING COSTUMES FOR WOMEN WITH EXTERNAL BREAST PROSTHESES IN THE NATURE OF REMOVABLE ENHANCER PADS USED THEREIN.

INT. CL. 35/U.S. CLS. 100, 101 AND 102

FOR ADVERTISING SERVICES; PUBLISHING OF ADVERTISING TEXTS; INTERACTIVE ADVERTISING ON A COMPUTER NETWORK; ADVERTISING AGENCIES; IMPORT-EXPORT AGENCIES; DEMONSTRATION OF GOODS FOR ADVERTISING PURPOSES AND FOR HOME SHOPPING PURPOSES; ORGANIZATION OF FAIRS AND EXHIBITIONS FOR COMMERCIAL OR ADVERTISING PURPOSES; SHOP-WINDOW DISPLAY ARRANGEMENT SERVICES; RETAIL STORE SERVICES FEATURING UNDERWEAR, SHOES, PERFUMERY, JEWELRY, LEATHER ARTICLES AND HABERDASHERY ARTICLES, FOODSTUFFS, ALCOHOLIC OR NON-ALCOHOLIC BEVERAGES, HOUSEHOLD ARTICLES, HOUSEHOLD UTENSILS; SALES PROMOTION FOR THIRD PARTIES; SUPPLY CHAIN MANAGEMENT SERVICES FOR THIRD PARTIES; WHOLESALE STORE SERVICES FEATURING CLOTHING, UNDERWEAR, SHOES, PERFUMERY, COSMETICS, JEWELRY, LEATHER ARTICLES AND HABERDASHERY ARTICLES, FOODSTUFFS, ALCOHOLIC OR NONALCOHOLIC BEVERAGES, HOUSEHOLD ARTICLES AND HOUSEHOLD UTENSILS.

ELEMENTS CORRECTED  
OWNER NAME

3,917,336. REG. 2-8-2011. DISNEY ENTERPRISES, INC. (DELAWARE CORPORATION) 500 SOUTH BUENA VISTA STREET, BURBANK, CA, 91521, SN 77-130,194. FILED 3-13-2007. PRINCIPAL REGISTER.

## WALT DISNEY

THE MARK CONSISTS OF STANDARD CHARACTERS WITHOUT CLAIM TO ANY PARTICULAR FONT, STYLE, SIZE, OR COLOR.

OWNER OF U.S. REG. NOS. 1,141,312, 3,235,413 AND OTHERS.

INT. CL. 9/U.S. CLS. 21, 23, 26, 36 AND 38

FOR AUDIO AND VISUAL RECORDINGS, INCLUDING RECORDINGS OF MOTION PICTURE FILMS AND TELEVISION SHOWS, FEATURING LIVE ACTION AND ANIMATED ENTERTAINMENT FOR CHILDREN; VIDEO GAME CARTRIDGES, DISCS AND SOFTWARE FEATURING MUSIC, STORIES, GAMES, AND ACTIVITIES FOR CHILDREN; COMPUTER GAME DISCS AND SOFTWARE FEATURING MUSIC, STORIES, GAMES, AND ACTIVITIES FOR CHILDREN; CONSUMER ELECTRONICS, NAMELY, CAMCORDERS, CAMERAS, COMPUTERS, DIGITAL CAMERAS, MP3 PLAYERS, AND VIDEO CAMERAS.

FIRST USE 10-22-2009; IN COMMERCE 10-22-2009.

INT. CL. 16/U.S. CLS. 2, 5, 22, 23, 29, 37, 38 AND 50

FOR PAPER AND CARDBOARD ARTICLES, NAMELY, POSTERS, STICKERS, TRADING CARDS; BOOKS, NAMELY, AUTOGRAPH BOOKS, A SERIES OF FICTION BOOKS, BOOKS FEATURING STORIES, GAMES AND ACTIVITIES FOR CHILDREN, CHILDREN'S ACTIVITY BOOKS, COMIC BOOKS, DIARIES, PHOTOGRAPH ALBUMS, PICTURE BOOKS, RECIPE BOOKS; STATIONERY; OFFICE SUPPLIES, NAMELY, BALL POINT PENS, AND STAPLERS; SCHOOL SUPPLIES, NAMELY, COLOR PENCILS, ERASERS, FELT PENS, MEMO PADS, PENCILS, PENCIL SHARPENERS, PEN AND PENCIL CASES, PENS, RUBBER STAMPS, AND WRITING IMPLEMENTS.

FIRST USE 10-23-2009; IN COMMERCE 10-23-2009.

ELEMENTS CORRECTED  
GOODS/SERVICES

# TRADEMARK REGISTRATIONS—NEW CERTIFICATES

New Certificates issued under section 7(d) of the Trademark Act of 1946 for the unexpired term of the original registrations.

3,443,469. EVONIK STANDARD CHARACTER MARK. 7(D) TO REGISTRANT.  
INT. CL. 2. LG VERWALTUNGS, GMBH, DORTMUND,  
FED REP GERMANY. REG. 6-10-2008. NEW CERT. SEC.

\* \* \* \* \*

# INDEX OF REGISTRANTS

APRIL 5, 2011

(Registered; Renewed; Canceled; Amended, Corrected, etc.; New Certificates; 12c Publications.)

The designation "U.S. Cl." appearing in this section refers to the U.S. class in effect prior to Sep. 1, 1973 rather than the international class which applies to applications filed on or after that date. For adoption of international classification see notice in the OFFICIAL GAZETTE of Jun. 26, 1973 (911 O.G. TM 210).

(PYRAMID SPACE, INC.)(PYRAMID SPACE) (PYRAMID SPACE ROCKET CAR), SAN DIEGO, CA:  
2,864,208, CANC. INT. CL. 42.

-M- ENTERTAINMENT & CONSULTANT SERVICE, INC., DECATUR, GA:  
3,940,609, PUB. 1-18-2011. INT. CL. 41.

"DELIC-POL" SPÓLKA AKCYJNA, POLAND:  
3,939,974, PUB. 1-18-2011. INT. CL. 30.

"DR. MARTENS" INTERNATIONAL TRADING GMBH, FED REP GERMANY AND "DR. MAERTENS" MARKETING GMBH, FED REP GERMANY:  
3,940,039, PUB. 1-18-2011. INT. CL. 25.

"GEORGIAN WINES & SPIRITS COMPANY" LTD., TELAVI, REP OF GEORGIA:  
2,864,178, CANC. INT. CL. 33.

A & A RESEARCH AND DEVELOPMENT W.L.L. (HOLDING), MANAMA, BAHRAIN:  
3,939,400, PUB. 11-30-2010. MULTIPLE CLASS, INT. CLS. 5 AND 25.  
3,939,401, PUB. 11-16-2010. INT. CL. 5.  
3,939,402, PUB. 1-11-2011. INT. CL. 5.  
3,939,403, PUB. 1-11-2011. INT. CL. 5.  
3,939,404, PUB. 1-4-2011. INT. CL. 5.

A BIRTH CONSULTANT CO., TULSA, OK:  
3,940,741, PUB. 1-18-2011. INT. CL. 41.

A F AND G, LLC, ANCHORAGE, AK:  
3,940,906, PUB. 1-18-2011. MULTIPLE CLASS, INT. CLS. 32 AND 43.

A SANI-CAN SERVICE, INC., DENVER, NC:  
2,426,712, REN. 2-25-11. INT. CL. 42.

A. C. GRACE COMPANY, INC., BIG SANDY, TX:  
3,941,617, INT. CL. 5.

A.I.J.J. ENTERPRISES, INC., BROOKLYN, NY:  
2,434,710, REN. 2-26-11. INT. CL. 25.

A.P. INDUSTRIES INC., QUEBEC, CANADA:  
2,367,442, CANC. INT. CL. 20.

A&E TELEVISION NETWORKS, LLC, NEW YORK, NY:  
3,939,526, PUB. 7-6-2010. MULTIPLE CLASS, INT. CLS. 9 AND 41.

AAC ASSOCIATES, INC., VIENNA, VA:  
2,865,742, CANC. INT. CL. 9.

AAR CORP., WOOD DALE, IL:  
2,475,025, REN. 2-26-11. MULTIPLE CLASS, INT. CLS. 6, 7, 12, 19, 20, 35, 37, 39 AND 42.

AARBAKKE MEDICAL & SCIENTIFIC AS, NORWAY:  
3,939,963, PUB. 1-18-2011. MULTIPLE CLASS, INT. CLS. 5, 10 AND 44.

AARO SYSTEMS AB, 100 28 STOCKHOLM, SWEDEN:  
2,864,089, CANC. MULTIPLE CLASS, INT. CLS. 9, 35, 41 AND 42.

AARON PIPES AND DANA LENNEMANN PARTNERSHIP, THE, MADERA, CA, DBA CALIFORNIA MOTORCYCLE ASSOCIATION:  
2,865,853, CANC. INT. CL. 41.

ABB SEATEC INC., HOUSTON, TX TO DRILLING CONTROLS, INC., HOUSTON, TX:  
2,028,350, CANC. INT. CL. 9.

ABBOTT LABORATORIES, ABBOTT PARK, IL:  
2,441,241, REN. 2-27-11. INT. CL. 5.  
3,941,878, INT. CL. 5.  
3,941,879, INT. CL. 5.

ABC-MART, INC., TOKYO, JAPAN:  
3,939,578, PUB. 1-18-2011. INT. CL. 25.

ABDALLAH INCORPORATED, BURNSVILLE, MN:  
2,536,353, REN. 2-26-11. INT. CL. 30.

ABELE BERTOZZI S.P.A., 43100 PARMA, ITALY:  
2,864,408, CANC. INT. CL. 29.

ABERCROMBIE & FITCH TRADING CO., NEW ALBANY, OH:  
3,942,325, INT. CL. 3.

ABILENE CHAMBER OF COMMERCE, ABILENE, TX, DBA ABILENE CONVENTION AND VISTOR'S BUREAU:  
3,941,753, INT. CL. 35.

ABLETON AG, 10119 BERLIN, FED REP GERMANY:  
3,939,890, PUB. 1-18-2011. MULTIPLE CLASS, INT. CLS. 9, 15, 16, 18, 25, 35, 38, 39, 40, 41, 42 AND 45.

ABOCA S.P.A. SOCIETA' AGRICOLA, ITALY:  
3,939,894, PUB. 1-18-2011. MULTIPLE CLASS, INT. CLS. 35 AND 42.

ABORIGINAL PRODUCTS, INC., SPRINGFIELD, IL:  
2,865,502, CANC. INT. CL. 28.

ABOULIAN, RAFIK, GENEVA, SWITZERLAND:  
2,864,934, CANC. MULTIPLE CLASS, INT. CLS. 3, 16, 33 AND 34.

ABRERA, S.A., ALFAJARIN, ZARAGOZA, SPAIN:  
2,865,857, CANC. INT. CL. 33.

ABREU ENTERTAINMENT LLC, TUCSON, AZ:  
3,940,411, PUB. 1-18-2011. INT. CL. 35.

ABYSS GROUP INC, STAMFORD, CT:  
3,942,403, INT. CL. 9.

ACCANTIA PERSONAL HYGIENE LIMITED, BIRMINGHAM B8 3DZ, UNITED KINGDOM:  
2,932,277, CANC. INT. CL. 5.

ACCELERA CORPORATION, BALTIMORE, MD:  
2,865,760, CANC. INT. CL. 41.

ACCENT PACKAGING INC., TOMBALL, TX, DBA ACCENT WIRE PRODUCTS:  
3,940,688, PUB. 1-18-2011. INT. CL. 7.

ACCESS COMMUNITY HEALTH NETWORK, CHICAGO, IL:  
3,941,212, INT. CL. 35.

ACCESS INNOVATIONS, INC., ALBUQUERQUE, NM:  
3,941,305, INT. CL. 9.

ACCOR, EVRY, FRANCE:  
2,864,746, CANC. MULTIPLE CLASS, INT. CLS. 35 AND 38.

ACD SYSTEMS LTD., VICTORIA, BRITISH COLUMBIA:  
2,864,052, CANC. INT. CL. 9.

ACDAT SYSTEM SERVICES LTD., CALGARY, ALBERTA T2P 4Z2, CANADA:  
2,511,748, CANC. INT. CL. 9.

ACDAT SYSTEM SERVICES LTD., CALGARY, ALBERTA, CANADA:  
2,539,761, CANC. INT. CL. 9.

ACHIEVE !MINNEAPOLIS, MINNEAPOLIS, MN:  
2,864,414, CANC. INT. CL. 41.

ACI, INC., NEW YORK, NY:  
3,941,626, INT. CL. 3.

ACORN INTERNATIONAL GROUP, INC, SUWANEE, GA:  
3,942,207, INT. CL. 35.

ACOSTA, FRANCISCO MARTIN, QUITO, ECUADOR:  
3,942,219, INT. CL. 30.

- ACOUSTIC HOME LOANS, LLC, ORANGE, CA:  
2,865,852, CANC. INT. CL. 36.
- ACRON POWER TRANSMISSION (ZHEJIANG) CO., LTD., CHINA:  
3,940,055, PUB. 1-18-2011. MULTIPLE CLASS, INT. CLS. 7 AND 12.
- ACROSS WORLD EDUCATION, LLC, BOSTON, MA:  
3,940,410, PUB. 1-18-2011. MULTIPLE CLASS, INT. CLS. 41 AND 42.
- ACS MARKETING, L.P., DALLAS, TX:  
2,429,654, REN. 2-26-11. INT. CL. 9.  
2,429,655, REN. 2-26-11. INT. CL. 9.
- ACTION FENCE CONTRACTORS, INC., MUNDELEIN, IL, DBA ACTION FENCE:  
3,941,135, MULTIPLE CLASS, INT. CLS. 6, 19 AND 37.
- ACTIONCOACH LIMITED, LUXEMBOURG VILLE, LUXEMBOURG:  
3,939,741, PUB. 1-18-2011. INT. CL. 35.
- ACTIONCOACH LIMITED, LUXEMBOURG VILLE L-201, LUXEMBOURG:  
3,939,742, PUB. 1-18-2011. INT. CL. 41.
- ACTIVA SNS, INC., CERRITOS, CA:  
2,865,317, CANC. INT. CL. 1.
- ACTIVE SINGLES, LLC, BEVERLY HILLS, CA, DBA ELITE MATCHMAKING:  
3,941,366, INT. CL. 45.
- ACTODAY FOUNDATION, INC., ATLANTA, GA:  
3,939,721, PUB. 1-18-2011. INT. CL. 36.
- AD BLOCKS, BIDDEFORD, ME:  
2,422,608, REN. 3-1-11. INT. CL. 9.
- ADA INC., GILBERT, AZ:  
2,865,138, CANC. INT. CL. 12.
- ADAMS GOLF, LTD., PLANO, TX:  
2,449,300, REN. 3-3-11. INT. CL. 28.
- ADAPTIVE MICRO SYSTEMS, INC., MILWAUKEE, WI:  
2,865,303, CANC. INT. CL. 9.
- ADCO ADVERTISING AGENCY, INC., PEORIA, IL:  
3,940,125, PUB. 1-18-2011. MULTIPLE CLASS, INT. CLS. 35 AND 42.
- ADDICO MANUFACTURING COMPANY, LINVILLE, NC:  
2,377,795, REN. 2-26-11. INT. CL. 12.
- ADERANS HAIR GOODS, INC., BEVERLY HILLS, CA:  
3,941,206, INT. CL. 3.
- ADOBE SPRINGS WATER CO., PATTERSON, CA:  
3,939,776, PUB. 1-18-2011. INT. CL. 41.
- ADOBE SYSTEMS INCORPORATED, SAN JOSE, CA:  
2,439,079, REN. 2-25-11. INT. CL. 9.  
2,864,988, CANC. MULTIPLE CLASS, INT. CLS. 9 AND 42.  
3,940,171, PUB. 1-18-2011. INT. CL. 36.  
3,940,172, PUB. 1-18-2011. INT. CL. 36.  
3,942,255, INT. CL. 42.
- ADOREABLE PROMOTIONS INC., BAY CITY, MI:  
2,578,744, CANC. INT. CL. 41.
- ADP, INC., ROSLAND, NJ:  
3,210,406, CANC. INT. CL. 36.
- ADPROTECH LIMITED, CB10 1XL, UNITED KINGDOM:  
2,863,973, CANC. MULTIPLE CLASS, INT. CLS. 5, 10 AND 42.
- ADTRAN, INC., HUNTSVILLE, AL:  
2,435,633, REN. 2-26-11. INT. CL. 9.
- ADVANCE AUTO INNOVATIONS, LLC, ROANOKE, VA:  
3,874,505, COR. MULTIPLE CLASS, INT. CLS. 6 AND 22.  
3,877,780, COR. INT. CL. 12.
- ADVANCE MAGAZINE PUBLISHERS INC., NEW YORK, NY:  
2,864,597, CANC. INT. CL. 41.
- ADVANCED AESTHETICS, INC., SPANISH FORK, UT:  
2,430,590, REN. 3-3-11. INT. CL. 5.
- ADVANCED DESIGN AND OPTIMIZATION TECHNOLOGIES, INC., BLACKSBURG, VA:  
2,766,025, CANC. INT. CL. 42.
- ADVANCED FIRE SYSTEMS, INC., HOPKINTON, MA:  
3,941,040, INT. CL. 37.
- ADVANCED FOOD SYSTEMS, INC., SOMERSET, NJ:  
3,940,444, PUB. 1-18-2011. MULTIPLE CLASS, INT. CLS. 40 AND 42.
- ADVANCED MATERIALS AND MANUFACTURING TECHNOLOGIES, LLC, GRANITE BAY, CA:  
3,940,822, PUB. 1-18-2011. MULTIPLE CLASS, INT. CLS. 35, 40 AND 42.
- ADVANCED MEDIA SERVICES, INC., CULVER CITY, CA:  
2,863,971, CANC. INT. CL. 35.
- ADVANCED NUTRIENTS LTD., ABBOTSFORD, BC, CANADA:  
3,941,688, INT. CL. 11.  
3,941,689, INT. CL. 11.  
3,941,691, INT. CL. 20.
- ADVANCED POLYMER, INC., CARLSTADT, NJ:  
3,942,298, INT. CL. 1.
- ADVANCED PREMISE TECHNOLOGIES, L.L.C., CHARLOTTE, NC:  
2,865,479, CANC. INT. CL. 40.
- ADVANCED PRESENTATION PRODUCTS INC., MISSISSAUGA, ONTARIO, CANADA:  
3,942,404, INT. CL. 35.
- ADVANTAGE DIRECT INTERNATIONAL, INC., RYE, NY:  
3,941,232, INT. CL. 3.
- ADVOCARE INTERNATIONAL, L.P., CARROLLTON, TX:  
2,865,309, CANC. MULTIPLE CLASS, INT. CLS. 3 AND 5.
- AERIS THERAPEUTICS, LLC, WOBURN, MA:  
3,942,227, MULTIPLE CLASS, INT. CLS. 5 AND 10.
- AERUS CONCEPTS, LP, DALLAS, TX:  
3,940,727, PUB. 1-18-2011. INT. CL. 11.
- AESTHETIC REJUVENATION CENTER, LLC, CRANSTON, RI:  
2,368,176, CANC. INT. CL. 42.
- AEZ LEICHTMETALLRADER GMBH, SIEGBURG, FED REP GERMANY:  
2,431,564, REN. 2-25-11. INT. CL. 12.  
2,457,102, REN. 2-26-11. INT. CL. 12.
- AFFILIAT LICENSE COMPANY, LLC, ARLINGTON, VA:  
2,367,621, CANC. INT. CL. 38.
- AFFILIATED FOODS, INC., AMARILLO, TX:  
3,939,583, PUB. 1-18-2011. INT. CL. 35.
- AFFILIATED NETWORK SERVICES, L.L.C., CHICAGO, IL:  
2,367,469, CANC. MULTIPLE CLASS, INT. CLS. 35 AND 36.
- AFFILIATED RESOURCES, INC., PORTLAND, OR:  
3,941,309, INT. CL. 19.
- AFFY TAPPLE, L.L.C., NILES, IL:  
3,940,208, PUB. 1-18-2011. INT. CL. 30.
- AFS TECHNOLOGIES, INC., PHOENIX, AZ:  
2,711,403, CANC. INT. CL. 42.
- AGA AKTIEBOLAG, 81 LIDINGO, SWEDEN:  
713,322, REN. 3-2-11. U.S. CL. 2 (INT. CLS. 6, 13, 14, 15, 16, 18, 20, 21, 22 AND 34).
- AGAPE CONDIMENTS & BEVERAGE, INC., VANCOUVER, WA, DBA THE GARLIC LADY:  
3,940,474, PUB. 1-18-2011. INT. CL. 32.
- AGAVEIRA CAMICHINES, S.A. DE C.V., JALISCO, C.P. 45601, MEXICO, MEXICO:  
3,788,729, CANC. INT. CL. 32.
- AGC, LLC, CLEVELAND, OH:  
2,369,454, CANC. MULTIPLE CLASS, INT. CLS. 16 AND 28.
- AGENCY.COM LLC, NEW YORK, NY:  
3,942,166, MULTIPLE CLASS, INT. CLS. 35 AND 42.
- AGENCY.COM, LTD., NEW YORK, NY:  
3,942,049, INT. CL. 42.
- AGOGO THREADS INC., GOLDEN, CO:  
2,865,311, CANC. INT. CL. 35.
- AGRICORE, INC., LEBANON, PA:  
2,368,021, CANC. INT. CL. 35.
- AGRÍCOLA CASTELLANA.; SDAD. COOP. LTDA., SPAIN:  
3,940,018, PUB. 1-18-2011. INT. CL. 33.
- AGUA CALIENTE CULTURAL MUSEUM, PALM SPRINGS, CA:  
2,865,302, CANC. INT. CL. 41.
- AHA AMERICAN HOMEOWNERS ASSOCIATION, INC., STAMFORD, CT:  
2,864,276, CANC. INT. CL. 36.
- AHC MEDIA LLC, WASHINGTON, DC:  
2,369,598, CANC. INT. CL. 16.

AHEAD, INC., NEW BEDFORD, MA:  
2,384,246. REN. 3-1-11. INT. CL. 25.

AHOLD LICENSING SARL, GENEVA, SWITZERLAND:  
3,942,452. INT. CL. 35.

AIDS HEALTHCARE FOUNDATION, LOS ANGELES, CA:  
3,939,608. PUB. 1-18-2011. INT. CL. 10.

AILERON, DAYTON, OH:  
3,941,437. MULTIPLE CLASS, INT. CLS. 35 AND 41.

AIM GROUP, PLC, SOUTHAMPTON HAMPSHIRE, ENGLAND:  
2,865,391. CANC. MULTIPLE CLASS, INT. CLS. 6, 11, 12 AND 17.  
2,865,394. CANC. MULTIPLE CLASS, INT. CLS. 6, 11, 12 AND 17.

AINSWORTH GAME TECHNOLOGY LIMITED, NEWINGTON, AUSTRALIA:  
3,941,959. INT. CL. 9.

AINSWORTH PET NUTRITION, INC., MEADVILLE, PA:  
2,428,851. REN. 2-25-11. INT. CL. 31.

AIR DIMENSIONAL DESIGN, INC., NORTH HOLLYWOOD, CA:  
2,429,524. REN. 3-3-11. INT. CL. 20.

AIRPHORIA, LLC, CHICAGO, IL:  
2,865,619. CANC. INT. CL. 38.

AISIN SEIKI KABUSHIKI KAISHA, AICHI-KEN, JAPAN, DBA AISIN SEIKI CO., LTD.:  
3,941,480. MULTIPLE CLASS, INT. CLS. 5, 9, 10 AND 11.

AIT, INC., GLASTONBURY, CT:  
2,369,487. CANC. INT. CL. 25.  
2,369,494. CANC. INT. CL. 25.  
2,369,497. CANC. INT. CL. 25.  
2,369,498. CANC. INT. CL. 25.

AIXA QUINONES, ORLANDO, FL:  
3,940,597. PUB. 1-18-2011. INT. CL. 18.

AKASHA, ANN ARBOR, MI:  
3,939,772. PUB. 1-18-2011. MULTIPLE CLASS, INT. CLS. 19, 20 AND 21.

AKITA, INC., WILMINGTON, DE:  
3,939,635. PUB. 1-18-2011. INT. CL. 21.

AKZO NOBEL PAINTS LLC, STRONGSVILLE, OH:  
3,034,485. CANC. INT. CL. 1.

ALABAMA TELCO CREDIT UNION, BIRMINGHAM, AL:  
2,865,452. CANC. INT. CL. 41.

ALACRON, INC., NASHUA, NH, ALACRON, INC., NASHUA, NH:  
2,530,851. REN. 3-2-11. INT. CL. 9.

ALBANESE, ISIDORO, MT. KISCO, NY:  
2,368,409. CANC. INT. CL. 42.

ALBECCA, INC., NORCROSS, GA TO COLUMBIA INSURANCE COMPANY, OMAHA, NE:  
2,367,913. CANC. INT. CL. 20.

ALBERT G. NICKERSON JR., JERSEY CITY, NJ AND STEPHEN PROVENZANO, JERSEY CITY, NJ:  
2,367,750. CANC. INT. CL. 16.

ALBERT, MELANIE ANNE, PHOENIX, AZ:  
3,940,499. PUB. 1-18-2011. INT. CL. 41.

ALBERTO-CULVER USA, INC., MELROSE PARK, IL:  
1,635,911. REN. 2-25-11. INT. CL. 3.

ALBRECHT, KATE, LOS ANGELES, CA, DBA MR. KATE:  
3,940,616. PUB. 1-18-2011. INT. CL. 14.

ALCOA HOME EXTERIORS, INC, PITTSBURGH, PA:  
2,367,868. CANC. INT. CL. 19.

ALCON RESEARCH, LTD., FORT WORTH, TX, ALCON LABORATORIES, INC., FORT WORTH, TX:  
929,014. REN. 3-3-11. U.S. CL. 18 (INT. CL. 5).

ALCORE INC, EDGEWOOD, MD, AMERICAN CYANAMID COMPANY, WAYNE, NJ:  
907,852. REN. 2-25-11. U.S. CL. 14 (INT. CL. 6).

ALDASORO RANCH HOMEOWNERS COMPANY, TELLURIDE, CO, AKA ALDASORO RANCH:  
3,940,636. PUB. 1-18-2011. INT. CL. 36.

ALDERFER, INC., HARLEYSVILLE, PA:  
2,865,042. CANC. INT. CL. 29.

ALDERSON, NEVA, SAN PEDRO, CA:  
3,941,846. INT. CL. 25.

ALDI INC., BATAVIA, IL:  
2,454,058. REN. 3-2-11. INT. CL. 29.

ALE ASYLUM, LLC, MADISON, WI:  
3,940,639. PUB. 1-18-2011. INT. CL. 32.  
3,940,643. PUB. 1-18-2011. INT. CL. 32.  
3,940,654. PUB. 1-18-2011. INT. CL. 32.

ALEXANDER JULIAN, INC., RIDGEBFIELD, CT:  
3,942,230. INT. CL. 24.

ALEXANDER, ANAND JON, NYC, NY:  
2,863,965. CANC. INT. CL. 25.

ALEXANDER, KEAWE, HONOLULU, HI:  
3,942,463. INT. CL. 25.  
3,942,464. INT. CL. 25.  
3,942,465. INT. CL. 25.

ALEXANDER, RIC R, CASTRO VALLEY, CA:  
3,940,371. PUB. 1-18-2011. INT. CL. 9.

ALEXANDER'S DIGITAL PRINTING, LINDON, UT:  
2,865,387. CANC. MULTIPLE CLASS, INT. CLS. 35 AND 42.

ALEXIS TEXAS ENTERTAINMENT, LOS ANGELES, CA:  
3,939,480. PUB. 1-18-2011. INT. CL. 41.

ALFALFA NAIL SUPPLY, INC., BATON ROUGE, LA:  
2,429,599. REN. 3-2-11. INT. CL. 3.

ALGER ASSOCIATES, INC., NEW YORK, NY:  
3,941,291. INT. CL. 36.

ALGORYX SIMULATION AB, UMEÅ, SWEDEN:  
3,939,975. PUB. 1-18-2011. MULTIPLE CLASS, INT. CLS. 9 AND 41.

ALISON & ASSOCIATES, INC., AUGUSTA, GA:  
2,864,103. CANC. INT. CL. 35.

ALKEMISTS PHARMACEUTICALS, COSTA MESA, CA:  
3,941,260. INT. CL. 1.

ALL AMERICAN CORPORATION, KENNEWICK, WA:  
3,942,333. INT. CL. 37.

ALL AMERICAN STORE, LLC, BROOKVILLE, OH:  
3,939,370. PUB. 1-18-2011. INT. CL. 35.

ALL WEATHER WINDOWS LTD., EDMONTON, ALBERTA T5S 2K7, CANADA:  
2,380,618. REN. 3-3-11. INT. CL. 19.

ALL-GLOBAL BUSINESS LLC, RENO, NV:  
3,941,499. INT. CL. 35.

ALL-STATE INTERNATIONAL, INC., CRANFORD, NJ:  
2,865,304. CANC. INT. CL. 9.

ALLAN KNIGHT & ASSOCIATES, INC, DALLAS, TX:  
3,939,363. PUB. 1-18-2011. INT. CL. 11.

ALLBOOKS4LESS.COM, INC., HAUPPAUGE, NY:  
2,381,990. CANC. INT. CL. 35.

ALLEGANTMD, INC., TAMPA, FL:  
3,940,606. PUB. 1-18-2011. INT. CL. 35.

ALLEGRO MFG. INC., COMMERCE, CO:  
3,941,313. MULTIPLE CLASS, INT. CLS. 24, 25 AND 28.

ALLERDERM LABORATORIES, INC., PHOENIX, AZ, TI-PHARMACEUTICALS, MOUNTAIN VIEW, CA:  
1,146,999. REN. 3-1-11. INT. CL. 3.

ALLEY CAT ALLIES, BETHESDA, MD:  
3,940,263. PUB. 1-18-2011. INT. CL. 35.

ALLFAST FASTENING SYSTEMS, INC., CITY OF INDUSTRY, CA:  
3,941,009. INT. CL. 6.

ALLIANCE ENTERTAINMENT, LLC, CORAL SPRINGS, FL:  
2,864,025. CANC. INT. CL. 9.

ALLIANCE GLOBAL GROUP II INC., WESTON, FL:  
3,941,900. MULTIPLE CLASS, INT. CLS. 9, 13, 18 AND 35.

ALLIANCE OF VISUAL ARTISTS, ATLANTA, GA, DBA STOCK ARTISTS ALLIANCE:  
3,940,715. PUB. 1-18-2011. INT. CL. 16.

ALLIANCE SHIPPERS, INC, ENGLEWOOD CLIFFS, NJ:  
3,940,375. PUB. 1-18-2011. INT. CL. 39.

ALLIANCE TRAVEL, LLC, SAN FRANCISCO, CA:  
2,864,945. CANC. INT. CL. 39.

ALLIANT TECHSYSTEMS INC., MINNEAPOLIS, MN:  
3,941,404. INT. CL. 13.

ALLIED OLD ENGLISH, INC., PORT READING, NJ, SAUCY SUE PRODUCTS, INC., BRIARCLIFF MANOR, NY:  
711,605. REN. 2-25-11. U.S. CL. 46 (INT. CL. 30).

ALLIED ADVERTISING LIMITED PARTNERSHIP, BOSTON, MA:  
3,941,693. MULTIPLE CLASS, INT. CLS. 35, 41 AND 42.

ALLING, JOHN PAUL, FOLSOM, CA:  
3,941,203. INT. CL. 35.

- ALLOY ENTERTAINMENT, NEW YORK, NY:  
2,725,766, CANC. INT. CL. 16.
- ALLSCRIPTS, LLC, CHICAGO, IL:  
3,940,924, PUB. 1-18-2011. MULTIPLE CLASS, INT. CLS.  
35 AND 42.
- ALLSOP, INC., BELLINGHAM, WA:  
3,941,163, INT. CL. 9.
- ALLSTATE INSURANCE COMPANY, NORTHBROOK, IL:  
3,941,956, INT. CL. 36.
- ALLURE BRIDALS, INC., BARTLETT, TN:  
3,939,702, PUB. 1-18-2011. INT. CL. 25.
- ALMIRALL, S.A., 08022 BARCELONA, SPAIN:  
2,864,057, CANC. INT. CL. 35.
- ALMOND JEWELERS, INC., GREAT NECK, NY:  
2,368,923, CANC. INT. CL. 14.
- ALOE VERA OF AMERICA, INC., DALLAS, TX:  
3,942,319, INT. CL. 5.
- ALOHA SURFBOARDS PTY LTD, NORTH SYDNEY, NSW  
2100, AUSTRALIA:  
1,635,581, REN. 3-2-11. INT. CL. 28.
- ALOTTA GROUP INC, ELK GROVE VILLAGE, IL:  
3,940,495, PUB. 1-18-2011. INT. CL. 35.
- ALPHA INDUSTRIES, INC., CHANTILLY, VA:  
1,634,188, REN. 2-26-11. INT. CL. 25.
- ALPHAGENOME, INC., NEW YORK, NY:  
2,745,172, CANC. INT. CL. 36.
- ALPHATEC SPINE, INC., CARLSBAD, CA:  
3,940,197, PUB. 1-18-2011. MULTIPLE CLASS, INT. CLS.  
10, 35, 40 AND 42.
- ALPINA SPORTS GMBH, FED REP GERMANY:  
3,940,052, PUB. 1-18-2011. INT. CL. 9.
- ALPINE INVESTMENT MANAGEMENT, LLC, ST. LOUIS,  
MO:  
3,942,165, INT. CL. 36.
- ALSENIH, LORI, ALLEN, TX, DBA EVER GIVING BOX:  
3,940,497, PUB. 1-18-2011. INT. CL. 16.
- ALT-N TECHNOLOGIES, LTD., GRAPEVINE, TX:  
2,430,783, REN. 2-26-11. INT. CL. 9.
- ALTEA FINANCIAL SERVICES GMBH, FED REP GER-  
MANY:  
3,940,020, PUB. 1-18-2011. INT. CL. 36.
- ALTERNATIVE SOLUTIONS, LLC, HUNTINGTON BEACH,  
CA:  
3,941,202, INT. CL. 34.
- ALTICOR INC., ADA, MI:  
1,468,193, CANC. INT. CL. 11.
- ALTRONIX CORPORATION, BROOKLYN, NY:  
3,291,859, CANC. INT. CL. 9.  
3,295,448, CANC. INT. CL. 9.
- ALTRUEON LLC, DALY CITY, CA:  
3,940,853, PUB. 1-18-2011. INT. CL. 10.
- ALTUNKAYA INSAAT NAKLIYAT GIDA TICARET ANO-  
NIM SIRKETI, GAZIANTEP, TURKEY:  
3,940,900, PUB. 1-18-2011. INT. CL. 32.
- ALVORD, BAKER & ASSOCIATES, LLC, ROCKVILLE, MD:  
3,939,369, PUB. 1-18-2011. INT. CL. 44.
- ALWAYS BUYING SCRAP, INC., DURHAM, NC:  
3,941,812, INT. CL. 35.
- AMAZON TOURS INC., COPPELL, TX:  
2,368,497, CANC. INT. CL. 42.
- AMBERGEN, INC., WATERTOWN, MA:  
2,486,012, REN. 2-26-11. INT. CL. 1.
- AMBERSON HOLDINGS LLC, NEW YORK, NY:  
3,044,659, AM. MULTIPLE CLASS, INT. CLS. 35, 38, 41  
AND 45.
- AMCOL INTERNATIONAL CORPORATION, HOFFMAN  
ESTATES, IL:  
2,539,214, REN. 2-26-11. INT. CL. 1.
- AMEE UK LIMITED, WHARF PLACE, LONDON, UNITED  
KINGDOM:  
3,939,910, PUB. 1-18-2011. MULTIPLE CLASS, INT. CLS.  
9, 35, 42 AND 45.
- AMEGY BANK NATIONAL ASSOCIATION, HOUSTON, TX:  
2,865,658, CANC. INT. CL. 36.
- AMERICA AT HOME, INC., DEERFIELD BEACH, FL:  
2,864,348, CANC. INT. CL. 36.
- AMERICA'S DRIVE-IN CORP., WICHITA, KS:  
2,864,941, CANC. INT. CL. 43.
- AMERICA'S PROMISE - THE ALLIANCE FOR YOUTH,  
WASHINGTON, DC:  
2,367,925, CANC. INT. CL. 41.
- AMERICAN ALL ACCESSORIES, EL MONTE, CA:  
2,864,586, CANC. INT. CL. 20.
- AMERICAN ASSOCIATION OF DIABETES EDUCATORS,  
INC., CHICAGO, IL:  
3,939,748, PUB. 1-18-2011. INT. CL. 41.
- AMERICAN ASSOCIATION OF VASCULAR SURGERY  
AND PHLEBOLOGY, INC., GRAND JUNCTION, CO:  
3,942,468, INT. CL. 35.
- AMERICAN ASSOCIATION OF VETERINARY STATE  
BOARDS, KANSAS CITY, MO:  
3,940,241, PUB. 1-18-2011. INT. CL. 35.
- AMERICAN BABY PRODUCTS, OAKLAND, CA:  
1,607,475, CANC. MULTIPLE CLASS, INT. CLS. 18, 20  
AND 25.
- AMERICAN BANKERS ASSOCIATION, WASHINGTON,  
DC:  
909,138, REN. 3-2-11. U.S. CL. 38 (INT. CL. 16).
- AMERICAN BIRKEBEINER SKI FOUNDATION, INC.,  
HAYWARD, WI:  
2,426,286, REN. 3-2-11. INT. CL. 41.
- AMERICAN CANCER SOCIETY, INC., ATLANTA, GA:  
2,372,391, REN. 2-25-11. MULTIPLE CLASS, INT. CLS. 16,  
36 AND 41.
- AMERICAN CITY BUSINESS JOURNALS INC., CHAR-  
LOTTE, NC:  
2,368,350, CANC. INT. CL. 41.
- AMERICAN COVERS, INC., BLUFFDALE, UT:  
3,941,926, INT. CL. 5.
- AMERICAN DEFENSE LAWYERS, PC, CLOVIS, CA:  
3,940,878, PUB. 1-18-2011. INT. CL. 45.
- AMERICAN DIETETIC ASSOCIATION, CHICAGO, IL:  
2,864,496, CANC. MULTIPLE CLASS, INT. CLS. 36 AND  
41.
- AMERICAN ENERGY RESTAURANT EQUIPMENT, INC.,  
SPRINGFIELD, VA:  
2,367,684, CANC. INT. CL. 3.
- AMERICAN EXPRESS MARKETING & DEVELOPMENT  
CORP., NEW YORK, NY:  
3,941,115, INT. CL. 35.
- AMERICAN FREESTYLE MOTOCROSS ASSOCIATION,  
IRVINE, CA:  
3,941,303, U.S. CL. 200.
- AMERICAN GARAGE, LLC, PISGAH FOREST, NC:  
3,942,360, INT. CL. 27.
- AMERICAN GAS ASSOCIATION, WASHINGTON, DC:  
2,542,130, REN. 3-2-11. INT. CL. 16.
- AMERICAN GOURMET IMPORTS, INC., SAN CARLOS, CA,  
FORMERLY AMERICAN ROYAL INTERNATIONAL,  
INC.:  
3,939,757, PUB. 1-18-2011. INT. CL. 29.
- AMERICAN GRAMAPHONE, OMAHA, NE:  
2,433,273, REN. 2-25-11. INT. CL. 9.
- AMERICAN HARDWARE MANUFACTURERS ASSOCIA-  
TION, SCHAUMBURG, IL:  
2,865,552, CANC. INT. CL. 35.
- AMERICAN HEALTH INFORMATION MANAGEMENT  
ASSOCIATION, CHICAGO, IL:  
3,939,699, PUB. 1-18-2011. U.S. CL. B.
- AMERICAN INSTITUTE FOR CHARTERED PROPERTY  
CASUALTY UNDERWRITERS, MALVERN, PA:  
3,939,838, PUB. 1-18-2011. MULTIPLE CLASS, INT. CLS.  
16, 35 AND 41.
- AMERICAN INSTITUTE OF CERTIFIED PUBLIC ACCOUN-  
TANTS, NEW YORK, NY:  
3,941,931, U.S. CL. 200.
- AMERICAN INSTITUTE OF FOOD DISTRIBUTION, INC.,  
FAIR LAWN, NJ:  
2,368,439, CANC. INT. CL. 16.
- AMERICAN INSURANCE ADMINISTRATORS, INC, ME-  
CHANICSBURG, PA:  
3,941,550, INT. CL. 35.
- AMERICAN INSURANCE MARKETING SERVICES, INC.,  
MONTGOMERY, AL:  
2,367,562, CANC. INT. CL. 36.

AMERICAN JEWELRY MFG, INC., NEW YORK, NY:  
3,941,181, INT. CL. 14.

AMERICAN LABELMARK COMPANY, CHICAGO, IL:  
3,940,221, PUB. 1-18-2011. MULTIPLE CLASS, INT. CLS. 9  
AND 35.

AMERICAN MEDICAL INFORMATICS ASSOCIATION,  
INC., BETHESDA, MD:  
3,939,656, PUB. 1-18-2011. MULTIPLE CLASS, INT. CLS.  
35 AND 41.

AMERICAN MUSEUM OF NATURAL HISTORY, NEW  
YORK, NY:  
2,447,566, REN. 2-26-11. INT. CL. 41.

AMERICAN NATIONAL PROPERTY AND CASUALTY  
COMPANY, SPRINGFIELD, MO:  
2,863,905, CANC. INT. CL. 36.

AMERICAN PARTNERS LLC, OAK BROOK, IL:  
3,939,819, PUB. 1-18-2011. MULTIPLE CLASS, INT. CLS.  
29 AND 30.

AMERICAN SEATING COMPANY, GRAND RAPIDS, MI:  
2,864,704, CANC. INT. CL. 35.  
3,942,085, INT. CL. 20.

AMERICAN SECURITY COUNCIL FOUNDATION, SEBAS-  
TIAN, FL:  
3,942,239, INT. CL. 41.

AMERICAN SILK MILLS CORPORATION, PLAINS, PA:  
2,569,665, CANC. INT. CL. 24.

AMERICAN SNOWSPORTS EDUCATION ASSOCIATION,  
INC. - EDUCATION FOUNDATION, LAKEWOOD, CO:  
3,939,418, PUB. 1-18-2011. INT. CL. 16.

AMERICAN SOCIETY OF COMPOSERS, AUTHORS AND  
PUBLISHERS, NEW YORK, NY:  
2,489,135, REN. 3-2-11. INT. CL. 36.

AMERICAN SOCIETY OF OPHTHALMIC PLASTIC & RE-  
CONSTRUCTIVE SURGERY, INC., MINNEAPOLIS, MN:  
3,940,081, PUB. 1-18-2011. INT. CL. 41.  
3,940,082, PUB. 1-18-2011. INT. CL. 44.

AMERICAN SPORTS DESIGN, CO., CENTERVILLE, OH:  
2,437,041, REN. 2-28-11. INT. CL. 12.

AMERICAN WATERCRAFT ASSOCIATION, INC., ASH-  
BURN, VA:  
2,450,223, REN. 2-25-11. INT. CL. 42.

AMERICAN WHEELCHAIR FOUNDATION, CAMARILLO,  
CA:  
3,941,515, INT. CL. 36.

AMERICATEL CORPORATION, IRVING, TX:  
2,434,457, REN. 2-26-11. INT. CL. 38.

AMERINET, INC., ST. LOUIS, MO:  
3,940,989, MULTIPLE CLASS, INT. CLS. 35 AND 44.

AMERIPLAN CORPORATION, PLANO, TX:  
2,865,807, CANC. INT. CL. 35.

AMERISTAR CASINOS, INC., LAS VEGAS, NV:  
2,864,010, CANC. INT. CL. 43.

AMERITOR FINANCIAL CORPORATION, WASHINGTON,  
DC:  
2,368,166, CANC. INT. CL. 36.

AMERITOX LTD, MIDLAND, TX:  
3,942,348, MULTIPLE CLASS, INT. CLS. 42 AND 44.

AMGEN INC., THOUSAND OAKS, CA:  
3,942,123, INT. CL. 36.

AMIDA CARE INC., NEW YORK, NY:  
3,941,654, INT. CL. 44.

AMIGA, INC., NEW YORK, WA:  
2,369,059, CANC. INT. CL. 9.

AMISH ORIGINS, LLC, WORLAND, WY:  
3,940,157, PUB. 1-18-2011. INT. CL. 5.

AMMEEN PROPERTIES, LLC, NEW YORK, NY:  
3,942,046, INT. CL. 25.

AMMINISTRAZIONE PATRIMONIO SEDE APOSTOLICA,  
CITTA' DEL VATICANO, VATICAN CITY:  
3,939,922, PUB. 1-18-2011. MULTIPLE CLASS, INT. CLS.  
14, 16, 18, 25, 28, 35, 41 AND 43.

AMOREPACIFIC CORPORATION, SEOUL, REPUBLIC OF  
KOREA:  
2,864,079, CANC. INT. CL. 3.

AMOROLOGY, INC., OSSINING, NY:  
2,368,204, CANC. INT. CL. 42.

AMPHENOL CORPORATION, WALLINGFORD, CT:  
2,423,664, REN. 2-26-11. INT. CL. 9.

AMPHIONS INNOVATIONS PLC, NEW YORK, NY:  
2,368,034, CANC. INT. CL. 16.

AMPRO INDUSTRIES, INC., MEMPHIS, TN:  
2,400,184, REN. 3-3-11. INT. CL. 3.  
2,526,930, CANC. INT. CL. 3.

AMROAD TECHNOLOGY INC., TAIPEI COUNTY, TAI-  
WAN:  
3,941,186, MULTIPLE CLASS, INT. CLS. 9, 35 AND 42.

AMULET MANUFACTURING COMPANY, INC., ARCATA,  
CA:  
2,461,490, REN. 2-26-11. INT. CL. 7.

AMY CUBBISON, CARLSBAD, CA, DBA LEAVE ME BE:  
3,941,537, INT. CL. 25.

AMY WITTE, CHICAGO, IL, DBA AMOEBIA CLOTHING:  
3,940,135, PUB. 10-12-2010. INT. CL. 25.

AN HONEST AUTO SHOP, PALMDALE, CA:  
2,864,730, CANC. INT. CL. 37.

ANA - AEROPORTOS DE PORTUGAL, S.A., PORTUGAL:  
3,939,899, PUB. 1-18-2011. MULTIPLE CLASS, INT. CLS.  
9, 36, 38 AND 39.

ANALEX CORPORATION, ALEXANDRIA, VA:  
2,864,707, CANC. INT. CL. 42.  
2,864,708, CANC. INT. CL. 42.

ANALYTICAL GRAPHICS, INC., EXTON, PA:  
2,470,247, REN. 3-2-11. INT. CL. 9.

ANALYTICAL GRAPHICS, INC., MALVERN, PA:  
2,865,310, CANC. INT. CL. 9.

ANALYTIX ON DEMAND, INC., IRVINE, CA:  
3,939,724, PUB. 1-18-2011. INT. CL. 35.

ANANIA, JENNIFER M, PEMBROKE, MA:  
3,940,804, PUB. 1-18-2011. INT. CL. 41.

ANASYOR, 75011 PARIS, FRANCE:  
2,367,444, CANC. INT. CL. 5.

ANCHORAGE CAPITAL MANAGEMENT, L.L.C., NEW  
YORK, NY:  
3,940,659, PUB. 1-18-2011. INT. CL. 36.

ANDERSEN ALUMNI ASSOCIATION, LLC, ATLANTA, GA:  
3,939,428, PUB. 1-18-2011. INT. CL. 41.  
3,939,429, PUB. 1-18-2011. INT. CL. 41.

ANDERSEN CORPORATION, BAYPORT, MN:  
2,368,864, CANC. INT. CL. 19.  
3,939,469, PUB. 1-18-2011. INT. CL. 19.

ANDERSEN, RICHARD L., TORRANCE, CA:  
2,865,523, CANC. INT. CL. 9.

ANDERSON, DAVE, AGOURA HILLS, CA:  
2,429,777, REN. 2-25-11. INT. CL. 16.

ANDERSONS, INC., THE, MAUMEE, OH:  
911,835, REN. 2-26-11. U.S. CL. 1 (INT. CL. 31).

ANDERSONS, INC., THE, MAUMEE, OH, ANDERSONS,  
THE, MAUMEE, OH:  
1,613,150, REN. 2-28-11. INT. CL. 31.  
1,613,152, REN. 2-28-11. INT. CL. 31.

ANDIS WINES, LLC, SUTTER CREEK, CA:  
3,941,500, INT. CL. 35.

ANDRITZ AUTOMATION INC., ROSWELL, GA:  
3,941,102, INT. CL. 9.

ANGELINAVAGABONDA GROUP, LLC, ROCHESTER, NY:  
3,941,529, MULTIPLE CLASS, INT. CLS. 18 AND 29.

ANGLERS OUTPOST, LLC, NICHOLASVILLE, KY:  
2,368,828, CANC. INT. CL. 35.

ANGOSTURA CANADA INC., WINNIPEG, CANADA:  
2,863,945, CANC. INT. CL. 33.

ANGRY ROBOT LIMITED, OXFORD, UNITED KINGDOM:  
3,941,132, INT. CL. 9.

ANHEUSER-BUSCH, INCORPORATED, ST. LOUIS, MO,  
LATROBE BREWING COMPANY, LATROBE, PA:  
386,223, REN. 2-28-11. U.S. CL. 48 (INT. CL. 32).

ANHUNG CORPORATION, LOS ANGELES, CA, DBA  
LUCKY TRADING CO.:  
1,643,762, REN. 3-2-11. INT. CL. 29.

ANNA SUI CORP., NEW YORK, NY:  
3,940,950, PUB. 1-18-2011. MULTIPLE CLASS, INT. CLS.  
18 AND 25.

ANNETTE GEORGE AND HAMPTON GEORGE, BOTH U.S.  
CITIZENS, AS TRUSTEES OF THE GEORGE FAMILY  
TRUST, CARPINTERIA, CA, DBA FIESTA HAT COM-  
PANY:  
2,863,886, CANC. INT. CL. 25.

- ANOTHER ATTIC, LTD., AMARILLO, TX:  
3,941,543, INT. CL. 39.
- ANTAAR&S S.P.A., CAVA MANARA (PAVIA), ITALY:  
2,368,971, CANC. MULTIPLE CLASS, INT. CLS. 29 AND 30.
- ANTHESIS ORGANIC SKINCARE INC., ASTORIA, NY:  
3,940,179, PUB. 1-18-2011. INT. CL. 3.
- ANTHONY ENTERPRISE, INC., OAK LAWN, IL:  
2,367,881, CANC. INT. CL. 20.
- ANTHONY LIFTGATES, INC., PONTIAC, IL:  
2,865,745, CANC. INT. CL. 12.
- ANTISEPTICA CHEMISCH-PHARMAZEUTISCHE PRODUKTE GMBH, PULHEIM-BRAUWEILER, FED REP GERMANY:  
2,865,063, CANC. INT. CL. 5.  
2,865,064, CANC. INT. CL. 5.  
2,865,065, CANC. INT. CL. 5.
- ANTONAKOS FLORIDAN, LLC, TAMPA, FL:  
3,942,070, INT. CL. 36.
- ANTONIO MIRO, S.L., 08017 BARCELONA, SPAIN:  
2,864,347, CANC. MULTIPLE CLASS, INT. CLS. 3, 14 AND 18.
- ANXIETY TREATMENT CENTER, LTD., SCHAUMBURG, IL:  
2,428,369, REN. 2-28-11. INT. CL. 42.
- AOL INC., DULLES, VA:  
3,941,242, INT. CL. 41.
- AOL LLC, DULLES, VA:  
2,864,301, CANC. MULTIPLE CLASS, INT. CLS. 38 AND 41.
- AON BENFIELD GLOBAL, INC., CHICAGO, IL:  
3,940,689, PUB. 1-18-2011. INT. CL. 36.
- AOXLAN GROUP LTD, LONDON, UNITED KINGDOM:  
2,717,645, CANC. INT. CL. 9.
- APARTMENT PRO'S, MOORHEAD, MN, APARTMENT PRO'S, MOORHEAD, MN:  
2,385,342, REN. 2-26-11. INT. CL. 39.
- APEX MICROELECTRONICS COMPANY; LIMITED, CHINA:  
3,939,942, PUB. 1-18-2011. MULTIPLE CLASS, INT. CLS. 2 AND 9.
- APODACA, GINNY, SEATTLE, WA:  
3,942,186, INT. CL. 31.
- APOLLO INDUSTRIES LIMITED, HANGZHOU, HONG KONG:  
3,941,807, INT. CL. 24.
- APOLLO SPORTS CO., LTD., KANAGAWA, JAPAN:  
1,638,191, REN. 3-2-11. MULTIPLE CLASS, INT. CLS. 9, 11, 12, 18, 25 AND 28.
- APP-UNIPATH, LLC, DENVER, CO, AKA UNIPATH:  
3,940,743, PUB. 1-18-2011. INT. CL. 10.
- APPAREL WORKS, INC., ENCINITAS, CA:  
2,601,653, CANC. INT. CL. 9.
- APPLETON, TAMMY, MURRELLS INLET, SC:  
3,940,818, PUB. 1-18-2011. INT. CL. 41.
- APPLIED INFORMATION TECHNOLOGY, LLC, HOPEWELL, NJ:  
2,623,760, CANC. INT. CL. 35.
- APPLIED MATERIALS GMBH & CO. KG, ALZENAU, FED REP GERMANY:  
3,939,781, PUB. 1-18-2011. INT. CL. 7.
- APPLIED MEDICAL RESEARCH, INC., AUSTIN, TX:  
2,865,750, CANC. INT. CL. 5.
- APPLIED SEISMIC RESEARCH CORPORATION, PLANO, TX:  
3,939,594, PUB. 1-18-2011. INT. CL. 7.
- APPRIVER, LLC, GULF BREEZE, FL:  
3,939,734, PUB. 1-18-2011. INT. CL. 42.
- APTARGROUP, INC, CRYSTAL LAKE, IL, PITTSWAY CORPORATION, CARY, IL:  
1,657,807, REN. 3-1-11. INT. CL. 21.
- APT3 PHOTOGRAPHY LLC, ALEXANDRIA, VA:  
3,939,802, PUB. 1-18-2011. MULTIPLE CLASS, INT. CLS. 35, 40 AND 41.
- APV NORTH AMERICA, INC., ROSEMONT, IL:  
716,085, REN. 2-28-11. U.S. CL. 23 (INT. CL. 7).
- AQUA TECHNOLOGY SYSTEMS, LLC, WESTON, WI:  
3,941,568, INT. CL. 32.
- AQUACONSULT ANLAGENBAU GES.M.B.H, AUSTRIA:  
3,940,054, PUB. 1-18-2011. MULTIPLE CLASS, INT. CLS. 11, 37 AND 42.
- AQUAFOLD INC., SUNNYVALE, CA:  
3,942,274, INT. CL. 9.
- AQUILON SOFTWARE INC., WEST VANCOUVER, BC, CANADA:  
3,939,650, PUB. 1-18-2011. INT. CL. 9.
- ARABICA FUNDING, INC., MELVILLE, NY:  
3,941,677, INT. CL. 35.  
3,941,678, INT. CL. 35.
- ARAG INSURANCE COMPANY, DES MOINES, IA, MIDWEST MUTUAL INSURANCE COMPANY, WEST DES MOINES, IA:  
1,148,320, REN. 3-2-11. INT. CL. 36.
- ARARAT COGNAC FACTORY 'A.K.Z.' LTD, ARMENIA:  
3,940,058, PUB. 1-18-2011. INT. CL. 33.
- ARCADE PICTURES, LLC, SANTA MONICA, CA:  
3,941,079, INT. CL. 9.
- ARCADIA DAIRY FARMS, INC., ARDEN, NC:  
3,942,007, INT. CL. 32.
- ARCANANETWORKS, INC., NEWARK, CA:  
3,941,476, INT. CL. 9.
- ARCHER, CAROL M., HOUSTON, TX:  
3,940,852, PUB. 1-18-2011. INT. CL. 45.
- ARCHIBUS, INC., BOSTON, MA:  
2,378,264, REN. 2-25-11. INT. CL. 9.  
2,390,593, REN. 3-1-11. INT. CL. 9.  
2,390,593, CANC. INT. CL. 42.
- ARCHOS, FRANCE:  
3,939,973, PUB. 1-18-2011. MULTIPLE CLASS, INT. CLS. 35, 38 AND 42.
- ARCHSTONE COMMUNITIES LLC, ENGLEWOOD, CO:  
2,865,585, CANC. INT. CL. 36.
- ARCHWAY INC., BARRIGADA, GUAM:  
3,941,805, INT. CL. 18.
- ARCOS, ARMANDO L., ALEXANDRIA, VA:  
2,747,488, CANC. INT. CL. 9.
- ARDWIN PRODUCTS LLC, ROYAL OAK, MI:  
3,940,901, PUB. 1-18-2011. INT. CL. 28.
- ARENA FOOTBALL LEAGUE LLC, CHICAGO, IL:  
2,865,577, CANC. MULTIPLE CLASS, INT. CLS. 16, 25 AND 41.
- ARES TRADING S.A., CH-1170 AUBONNE, SWITZERLAND:  
3,940,001, PUB. 1-18-2011. INT. CL. 5.
- ARETI II LIMITED, JACKSONVILLE, FL:  
3,941,258, INT. CL. 35.
- ARGANESE INTERNATIONAL, LLC, WESTERLY, RI:  
3,940,893, PUB. 1-18-2011. INT. CL. 34.
- ARGON TECHNOLOGY CORPORATION, MISSISSAUGA, ONTARIO, CANADA:  
2,865,824, CANC. INT. CL. 9.
- ARISTO IMPORT CO., INC., ORANGEBURG, NY:  
907,990, REN. 3-1-11. U.S. CL. 27 (INT. CL. 14).
- ARISTOCRAT TECHNOLOGIES AUSTRALIA PTY LTD., NORTH RYDE, NSW, AUSTRALIA:  
3,939,723, PUB. 1-18-2011. INT. CL. 9.  
3,939,725, PUB. 1-18-2011. INT. CL. 9.
- ARISTOCRAT TECHNOLOGIES AUSTRALIA PTY LTD., LAS VEGAS, AUSTRALIA:  
3,939,726, PUB. 1-18-2011. INT. CL. 9.
- ARISTOCRAT TECHNOLOGIES AUSTRALIA PTY LTD., NORTH RYDE, NSW, AUSTRALIA:  
3,939,778, PUB. 1-18-2011. INT. CL. 9.  
3,939,828, PUB. 1-18-2011. INT. CL. 9.  
3,940,168, PUB. 1-18-2011. INT. CL. 9.  
3,940,169, PUB. 1-18-2011. INT. CL. 9.
- ARIZONA FEDERAL CREDIT UNION, PHOENIX, AZ:  
2,865,805, CANC. INT. CL. 36.
- ARJO HOSPITAL EQUIPMENT AB, ORG. NO. 556247-0145, ESLOV, SWEDEN:  
2,393,821, REN. 2-25-11. INT. CL. 10.  
2,396,146, REN. 2-26-11. INT. CL. 10.
- ARK 14, CALABASAS, CA:  
2,865,638, CANC. INT. CL. 9.
- ARKEMA INC., PHILADELPHIA, PA:  
3,940,962, PUB. 1-18-2011. INT. CL. 1.



ARLENE TAVEROFF, DOLLARD DES ORMEAUX, CANADA, DBA WISDOM A LA CARTE:  
3,941,986, INT. CL. 41.

ARMS REACH CONCEPTS, INC., MALIBU, CA:  
2,367,369, CANC. INT. CL. 20.

ARNAUTOVICH, ANDREY ASIMOVICH, SAINT-PETERSBURG, RUSSIAN FED.:  
3,942,429, INT. CL. 9.

ARNOLD, SCOTT, HOUSTON, TX:  
2,864,963, CANC. MULTIPLE CLASS, INT. CLS. 25, 35 AND 41.

ARQUATI S.R.L., SALA BAGANZA (PARMA), ITALY:  
3,939,732, PUB. 1-18-2011. INT. CL. 20.  
3,939,733, PUB. 1-18-2011. INT. CL. 22.

ARRIE WALLIE BEHEER B.V., SOEST, NETHERLANDS:  
2,430,787, REN. 2-26-11. INT. CL. 18.

ART & SCIENCE GROUP, INC., BALTIMORE, MD:  
2,865,840, CANC. INT. CL. 35.

ART BEHIND BARS, INC., KEY WEST, FL:  
2,368,509, CANC. INT. CL. 41.

ARTE AMERICAS, INC., MIAMI, FL:  
3,940,210, PUB. 1-18-2011. INT. CL. 41.

ARTELIS, SOCIÉTÉ ANONYME, BELGIUM:  
3,939,881, PUB. 1-18-2011. MULTIPLE CLASS, INT. CLS. 1, 5, 7, 9, 10 AND 42.

ARTHUR G. RUSSELL COMPANY, INCORPORATED, THE, BRISTOL, CT:  
925,062, REN. 2-26-11. U.S. CL. 23 (INT. CL. 7).

ARTVIC, LLC, NEW YORK, NY:  
3,941,231, INT. CL. 41.

ARUTT, CHERYL A, BEVERLY HILLS, CA, DBA CHERYL ARUTT, PSY.D.:  
3,940,824, PUB. 1-18-2011. INT. CL. 44.

AS IP HOLDINGS, INC., BOSTON, MA:  
3,939,361, PUB. 1-18-2011. INT. CL. 25.

ASBURY COLLEGE, WILMORE, KY:  
2,865,579, CANC. INT. CL. 41.

ASHER HEMP GELATO INC., WASHINGTON, DC:  
3,941,817, INT. CL. 30.

ASHLAND LICENSING AND INTELLECTUAL PROPERTY LLC, DUBLIN, OH:  
2,367,580, CANC. INT. CL. 42.  
3,941,508, INT. CL. 36.

ASHLAR MEDICAL, L.L.C., NATCHITOCHE, LA:  
3,941,261, INT. CL. 42.

ASHLEY, PEPE DAVID, CLIFTON PARK, NY, DBA EMPIRE SIGNS & GRAPHICS:  
3,940,256, PUB. 1-18-2011. INT. CL. 16.

ASHOKA: INNOVATORS FOR THE PUBLIC, ARLINGTON, VA:  
3,939,664, PUB. 1-18-2011. INT. CL. 45.  
3,939,665, PUB. 1-18-2011. MULTIPLE CLASS, INT. CLS. 35 AND 41.

ASI COMPUTER SYSTEMS, INC., CEDAR FALLS, IA:  
2,484,355, REN. 2-25-11. INT. CL. 9.

ASI SIGN SYSTEMS, INC., DALLAS, TX:  
2,368,900, CANC. MULTIPLE CLASS, INT. CLS. 6, 9, 19, 20 AND 21.

ASKO, INC., HOMESTEAD, PA:  
1,625,653, REN. 2-26-11. INT. CL. 7.

ASPECT SOFTWARE, INC., WESTFORD, MA:  
2,865,471, CANC. MULTIPLE CLASS, INT. CLS. 35 AND 38.

ASSEMBLED PRODUCTS CORPORATION, ROGERS, AR, DBA SPRAY MASTER TECHNOLOGIES:  
2,430,328, REN. 2-26-11. INT. CL. 7.  
2,430,334, REN. 2-26-11. INT. CL. 7.

ASSOCIATED HYGIENIC PRODUCTS LLC, DULUTH, GA:  
3,940,940, PUB. 1-18-2011. INT. CL. 16.

ASSURED FLOW SALES, INC, SARASOTA, FL:  
2,481,491, REN. 3-3-11. INT. CL. 11.

ASTELLAS PHARMA INC., JAPAN:  
3,939,879, PUB. 6-2-2009. INT. CL. 5.

ASTOR HOME LTD., ELMWOOD PARK, NJ:  
3,940,868, PUB. 1-18-2011. INT. CL. 33.

ASTRA INC., FORT LAUDERDALE, FL:  
2,368,618, CANC. INT. CL. 39.

ASTRAZENECA UK LIMITED, LONDON W1Y 6LN, UNITED KINGDOM:  
2,864,862, CANC. INT. CL. 5.

ASTRAZENECA UK LIMITED, LONDON, UNITED KINGDOM:  
3,941,225, INT. CL. 5.

ASTRO INN, LTD., HOUSTON, TX:  
2,530,216, REN. 2-25-11. INT. CL. 42.

AT&T INTELLECTUAL PROPERTY II, L.P., RENO, NV:  
3,941,517, INT. CL. 9.

ATAN PLASTIC CO., LTD., TAINAN HSIEN, TAIWAN:  
2,369,126, CANC. INT. CL. 9.

ATARAXIA, INC., BENSLEM, PA:  
2,864,706, CANC. INT. CL. 40.

ATCHLEY, KERI B., DANIELSVILLE, GA, DBA THE DOGS OF 30A, LLC:  
3,942,372, INT. CL. 25.

ATHLETA, INC., PETALUMA, CA:  
3,940,986, INT. CL. 18.

ATHLETICUTS, VISTA, CA:  
2,865,727, CANC. INT. CL. 44.

ATI PROPERTIES, INC., ALBANY, OR:  
282,547, REN. 3-3-11. U.S. CL. 14 (INT. CL. 6).  
3,939,511, PUB. 1-18-2011. INT. CL. 6.

ATLANTA HISTORICAL SOCIETY, INC., ATLANTA, GA, DBA ATLANTA HISTORY CENTER:  
3,940,603, PUB. 1-18-2011. INT. CL. 36.

ATLANTA TOYOTA, INC., DULUTH, GA:  
1,558,931, CANC. INT. CL. 12.

ATLANTIC DIVING SUPPLY, INC., VIRGINIA BEACH, VA:  
3,941,492, INT. CL. 9.

ATLANTIC OPTICAL COMPANY, INCORPORATED, CHATSWORTH, CA:  
1,646,739, REN. 3-3-11. INT. CL. 9.

ATLANTIC REFINING & MARKETING CORP., PHILADELPHIA, PA:  
2,419,067, REN. 3-3-11. INT. CL. 35.  
2,419,073, REN. 3-3-11. INT. CL. 35.

ATLANTIC RICHFIELD COMPANY, WARRENVILLE, IL:  
3,941,764, INT. CL. 32.

ATLAS COPCO AIRPOWER, NAAMLOZE VENNOOTSCHAP, B-2610 WILRIJK, BELGIUM:  
2,864,020, CANC. INT. CL. 7.

ATLAS COPCO COMPRESSORS LLC, WESTFIELD, MA:  
2,434,620, REN. 3-1-11. MULTIPLE CLASS, INT. CLS. 37 AND 40.

ATLAS SOUND LP, ENNIS, TX:  
3,941,345, INT. CL. 9.

ATM METABOLICS LLLP, WINTER HAVEN, FL:  
3,941,075, INT. CL. 5.

ATRONIC INTERNATIONAL GMBH, LUBBECKE, FED REP GERMANY:  
2,863,984, CANC. INT. CL. 9.

AUDIOWEB, LLC, PALATINE, IL:  
2,367,787, CANC. MULTIPLE CLASS, INT. CLS. 35, 38 AND 42.

AUSTIN, TRACY, BRONX, NY:  
3,941,872, INT. CL. 25.

AUSTRALIAN GOLD, INC., INDIANAPOLIS, IN:  
2,865,588, CANC. INT. CL. 3.

AUTO CRUISE AMERICA LLC, BEDMINSTER, PA:  
3,941,321, INT. CL. 42.

AUTO EUROPE, LLC, PORTLAND, ME:  
3,940,973, PUB. 1-18-2011. INT. CL. 39.

AUTODESK USER GROUP INTERNATIONAL, INC., TAMPA, FL:  
2,864,736, CANC. INT. CL. 16.

AUTOMATIC FILTERS, INC., LOS ANGELES, CA:  
2,475,693, REN. 3-3-11. INT. CL. 11.

AUTOMATTIC INC., SAN FRANCISCO, CA:  
3,941,584, INT. CL. 42.

AUTOMOBILE CLUB OF SOUTHERN CALIFORNIA, COSTA MESA, CA:  
2,539,741, CANC. INT. CL. 36.

AUTOMOTIVE FINANCE CORPORATION, INDIANAPOLIS, IN:  
3,942,428, INT. CL. 36.

- AUTOONLINE GMBH INFORMATIONSSYSTEME, NEUSS, FED REP GERMANY:  
3,939,506, PUB. 1-18-2011. MULTIPLE CLASS, INT. CLS. 9, 35, 38, 39 AND 42.
- AUTOTEC, LLC, BIRMINGHAM, AL:  
3,940,650, PUB. 1-18-2011. INT. CL. 35.
- AVA DESIGN LLC, NEW YORK, NY:  
3,942,101, INT. CL. 25.  
3,942,102, INT. CL. 25.
- AVANTEE RSI LLC, MASSAPRQUA, NY:  
2,368,725, CANC. INT. CL. 35.
- AVEDA CORPORATION, MINNEAPOLIS, MN, AVEDA CORPORATION, MINNEAPOLIS, MN:  
2,459,903, REN. 3-1-11. INT. CL. 3.
- AVENIR LIFESTYLES CORP., SCOTTSDALE, AZ:  
3,941,395, INT. CL. 43.  
3,941,396, INT. CL. 44.  
3,941,397, INT. CL. 43.  
3,941,398, INT. CL. 44.  
3,941,399, INT. CL. 43.
- AVENTIS PHARMA S.A., 92160 ANTONY, FRANCE:  
2,863,932, CANC. INT. CL. 5.
- AVIANCE MARKETING, INC., WASHINGTON, DC:  
2,865,315, CANC. INT. CL. 16.  
2,865,316, CANC. INT. CL. 16.
- AVILES, MIRANDA L., KATY, TX:  
3,941,851, INT. CL. 38.
- AVINDY DESIGNS, ATLANTA, GA:  
2,864,801, CANC. INT. CL. 14.
- AWI ACQUISITION COMPANY, SYLMAR, CA, DBA ALLIED INTERNATIONAL:  
2,430,280, REN. 2-26-11. INT. CL. 8.
- AXCAN PHARMA INC., MONT-SAINT-HILAIRE, QUEBEC, CANADA, MARION LABORATORIES, INC., KANSAS CITY, MO:  
1,155,249, REN. 3-2-11. INT. CL. 5.
- AXEL KAISER, ITALY:  
3,939,886, PUB. 12-29-2009. MULTIPLE CLASS, INT. CLS. 18 AND 25.
- AXXIOM MANUFACTURING, INC., FRESNO, TX:  
3,942,386, INT. CL. 6.
- AYDELOTTE, KEVIN, DENVER, CO:  
2,558,453, CANC. INT. CL. 42.
- AZ LASER CLINIC, INC., GLENDALE, AZ:  
3,942,395, INT. CL. 44.
- AZTEC FINANCE CORPORATION, PORT LOUIS, MAURITIUS:  
2,864,136, CANC. INT. CL. 3.
- AZUR LIMITED, LONDON, UNITED KINGDOM:  
3,942,028, INT. CL. 43.
- A10 NETWORKS, INC., SAN JOSE, CA:  
3,941,089, INT. CL. 9.
- B & J ENTERPRISES, LTD, ROCKVILLE, MD:  
3,939,877, PUB. 12-25-2007. INT. CL. 35.
- B. LANE INCORPORATED, NEW YORK, NY:  
3,940,340, PUB. 1-18-2011. INT. CL. 35.
- BABCOCK & WILCOX POWER GENERATION GROUP, INC., BARBERTON, OH:  
2,446,782, REN. 3-2-11. INT. CL. 11.
- BABOLAT VS, 69007 LYON, FRANCE:  
2,430,662, REN. 2-26-11. INT. CL. 28.  
2,430,663, REN. 2-26-11. INT. CL. 28.
- BABY INSIGHT LLC, POTOMAC, MD:  
2,864,987, CANC. MULTIPLE CLASS, INT. CLS. 40, 41 AND 44.
- BABY TOGS, INC., NEW YORK, NY:  
2,369,204, CANC. INT. CL. 25.
- BABYCENTER, INC., SAN FRANCISCO, CA TO BABYCENTER, LLC, SAN FRANCISCO, CA:  
2,613,080, CANC. MULTIPLE CLASS, INT. CLS. 16, 35 AND 42.
- BABYHEAD PRODUCTIONS, INC., WEST HOLLYWOOD, CA:  
2,369,369, CANC. INT. CL. 9.
- BACK PORCH PRODUCTIONS LLC, NASHVILLE, TN:  
3,940,691, PUB. 1-18-2011. INT. CL. 35.
- BACKFLOW SOLUTIONS, INC., JACKSON, MS:  
2,864,724, CANC. INT. CL. 35.
- BACON, MONICA RENEE', LOS ANGELES, CA:  
3,942,147, MULTIPLE CLASS, INT. CLS. 35 AND 41.
- BADESSA, GLEN, CRANSTON, RI:  
2,263,713, CANC. INT. CL. 3.
- BADGER METER, INC., MILWAUKEE, WI:  
3,940,582, PUB. 1-18-2011. INT. CL. 9.
- BAGDASRIAN PRODUCTIONS, LLC, MONTECITO, CA:  
2,864,434, CANC. INT. CL. 41.
- BAIER & KÖPPEL GMBH & CO., PEGNITZ, FED REP GERMANY:  
3,940,262, PUB. 1-18-2011. MULTIPLE CLASS, INT. CLS. 7 AND 12.
- BAKER & MCKENZIE LLP, CHICAGO, IL:  
2,865,434, CANC. MULTIPLE CLASS, INT. CLS. 9, 38 AND 42.
- BAKER, KNAPP & TUBBS, INC., RALEIGH, NC:  
3,940,771, PUB. 1-18-2011. MULTIPLE CLASS, INT. CLS. 11, 21 AND 42.
- BAKERS FOOTWEAR GROUP INC., ST. LOUIS, MO:  
3,875,198, COR. INT. CL. 25.
- BALANCE FITNESS STUDIO, MINNEAPOLIS, MN:  
2,864,824, CANC. INT. CL. 41.
- BALDOR ELECTRIC COMPANY, FORT SMITH, AR:  
2,368,889, CANC. INT. CL. 7.
- BALDWIN-LINDSEY, JANICE, PENSACOLA, FL AND BALDWIN, HERBERT A., PENSACOLA, FL AND BALDWIN-TALTON, CAROLYN, PENSACOLA, FL AND BALDWIN, LUTHER J., PENSACOLA, FL AND BALDWIN-HARVEY, PATRICIA, PENSACOLA, FL AND BALDWIN, MARK B., PENSACOLA, FL AND BALDWIN, STEVE G., PENSACOLA, FL AND BALDWIN-WILLIAMS, PERRILEE A., PENSACOLA, FL:  
3,941,247, INT. CL. 43.
- BALL HORTICULTURAL COMPANY, WEST CHICAGO, IL:  
3,940,937, PUB. 1-18-2011. MULTIPLE CLASS, INT. CLS. 9 AND 16.
- BALL SCREWS & ACTUATORS CO., INC., SAN JOSE, CA:  
2,447,842, REN. 3-3-11. INT. CL. 4.
- BALL STATE UNIVERSITY, MUNCIE, IN:  
1,636,173, REN. 2-26-11. INT. CL. 21.
- BAMA FEVER, INC., PELHAM, AL:  
2,685,946, CANC. INT. CL. 25.
- BAMBOO BARE, INC., CORONA, CA:  
3,940,478, PUB. 1-18-2011. INT. CL. 24.
- BANC OF AMERICA COMMUNITY DEVELOPMENT CORPORATION, CHARLOTTE, NC:  
3,941,315, MULTIPLE CLASS, INT. CLS. 35, 36 AND 37.
- BANCA AKROS S.P.A., MILANO, ITALY:  
2,863,938, CANC. INT. CL. 36.
- BANCFIRST CORPORATION, OKLAHOMA CITY, OK:  
1,637,824, REN. 3-3-11. INT. CL. 36.
- BANCVUE, LTD., AUSTIN, TX:  
3,941,147, MULTIPLE CLASS, INT. CLS. 35 AND 36.
- BAND KITTY, LLC, BRECKENRIDGE, CO:  
3,941,056, INT. CL. 35.
- BANFI PRODUCTS CORPORATION, OLD BROOKVILLE, NY:  
3,941,924, INT. CL. 33.
- BANK OF SOUTHERN CALIFORNIA, N.A., SAN DIEGO, CA:  
3,942,379, INT. CL. 36.
- BANKSYS, SOCIÉTÉ ANONYME, BELGIUM:  
3,213,610, COR. MULTIPLE CLASS, INT. CLS. 9, 36, 37, 38 AND 42.
- BANNER SEVENTEEN, LLC, BOSTON, MA:  
2,532,515, REN. 3-1-11. INT. CL. 41.
- BAPTISTE, JASON, LAS VEGAS, NV AND BAPTISTE, ISRAEL, NASHVILLE, TN:  
2,865,695, CANC. INT. CL. 25.
- BAR GAME PROMOTIONS, INC., DULUTH, GA:  
3,940,137, PUB. 1-18-2011. MULTIPLE CLASS, INT. CLS. 35 AND 41.  
3,940,139, PUB. 1-18-2011. MULTIPLE CLASS, INT. CLS. 35 AND 41.
- BAR, CLAUDIO ALEJANDRO, PCIA DE BUENOS AIRES, ARGENTINA:  
2,864,325, CANC. MULTIPLE CLASS, INT. CLS. 30 AND 35.

BAR'S PRODUCTS, INC., HOLLY, MI:  
3,942,048, MULTIPLE CLASS, INT. CLS. 1 AND 35.

BARBIC, IVO, ATLANTA, GA:  
2,368,061, CANC. INT. CL. 16.

BARCHARTS, INC., BOCA RATON, FL:  
2,865,062, CANC. INT. CL. 28.

BARCO UNIFORMS, INC., GARDENA, CA, BARCO OF CALIFORNIA, GARDENA, CA:  
897,406. REN. 3-1-11. U.S. CL. 39 (INT. CL. 25).

BARIL COATINGS B.V., NL-5234 GL 'S-HERTOGENBOSCH, NETHERLANDS:  
3,940,032, PUB. 1-18-2011. MULTIPLE CLASS, INT. CLS. 1, 2 AND 3.

BARISTA ENTERTAINMENT, LLC, SAN FRANCISCO, CA, DBA BARISTA ENTERTAINMENT:  
3,939,543, PUB. 1-18-2011. MULTIPLE CLASS, INT. CLS. 9, 38 AND 41.

BARKSDALE, INC., LOS ANGELES, CA, BARKSDALE VALVES, LOS ANGELES, CA:  
712,390. REN. 3-3-11. U.S. CL. 13 (INT. CL. 7).

BARLEAN'S ORGANIC OILS, FERNDALE, WA:  
2,368,256, CANC. INT. CL. 29.

BARNESGOULD, SANDY, APPLE VALLEY, CA AND GOULD, WILLIAM, APPLE VALLEY, CA AND POLLOCK, ROBERT, APPLE VALLEY, CA:  
3,941,513, INT. CL. 43.

BARNETT OUTDOORS, LLC, TARPON SPRINGS, FL:  
3,941,457, INT. CL. 28.

BARNETT, VALERIE D., NEW ROCHELLE, NY:  
3,941,574, INT. CL. 21.

BARNSTORMERS INC, CARSON CITY, NV:  
3,940,810, PUB. 1-18-2011. INT. CL. 35.

BAROMETRIX SOFTWARE CORPORATION, FRAMINGHAM, MA:  
2,865,057, CANC. INT. CL. 41.

BARON, WENDY, WOODINVILLE, WA:  
3,940,736, PUB. 1-18-2011. MULTIPLE CLASS, INT. CLS. 16 AND 18.

BARRAS' CAJUN CREOLE HOT LINKS, LLC, ST. MARTINVILLE, LA:  
2,865,803, CANC. INT. CL. 29.

BARRATT ALAN RICHARD, SOLIHULL, UNITED KINGDOM:  
3,941,453, INT. CL. 5.

BARRETT, BRAD, ORLANDO, FL, AKA ATLANTIC COAST CASUALTY:  
3,942,456, INT. CL. 36.

BARRY CALLEBAUT FRANCE, SOCIÉTÉ PAR ACTIONS SIMPLIFIÉE, F-78250 MEULAN, FRANCE:  
3,940,046, PUB. 1-18-2011. MULTIPLE CLASS, INT. CLS. 29, 30 AND 31.

BARTH & MCCALLIG, LLC, JUPITER, FL:  
3,942,086, INT. CL. 18.

BASEBALL ACQUISITION CORPORATION, WILSONVILLE, OR, BASEBALL ACQUISITION CORPORATION, WILSONVILLE, OR:  
2,534,613. REN. 3-2-11. MULTIPLE CLASS, INT. CLS. 18, 21, 25 AND 28.

BASELL TECHNOLOGY COMPANY BV, HOOFDDORP 2132, NETHERLANDS:  
711,971. REN. 2-26-11. MULTIPLE CLASS, U.S. CLS. 1 (INT. CL. 1) AND 6 (INT. CL. 1).

BASF CORPORATION, FLORHAM PARK, NJ:  
1,626,504. REN. 3-1-11. MULTIPLE CLASS, INT. CLS. 1, 2 AND 3.

BASF CORPORATION, MOUNT OLIVE, NJ:  
2,864,055, CANC. MULTIPLE CLASS, INT. CLS. 1 AND 17.

BASF SE, FED REP GERMANY:  
3,940,069, PUB. 1-18-2011. MULTIPLE CLASS, INT. CLS. 1 AND 5.

BASIC CONCEPTS INTERNATIONAL LIMITED, TSIM SHA TSUI EAST, HONG KONG:  
3,941,160, INT. CL. 28.

BATAVUS B.V., NETHERLANDS:  
3,939,954, PUB. 1-18-2011. MULTIPLE CLASS, INT. CLS. 12, 14, 18 AND 25.  
3,940,002, PUB. 1-18-2011. MULTIPLE CLASS, INT. CLS. 12, 14, 18 AND 25.

BATH & BODY WORK BRAND MANAGEMENT, INC., REYNOLDSBURG, OH:  
2,539,504. REN. 3-2-11. INT. CL. 3.

BATH & BODY WORKS BRAND MANAGEMENT, INC., REYNOLDSBURG, OH:  
3,941,401, INT. CL. 3.

BATINAU DESIGN GROUP, INC., KANSAS CITY, MO:  
3,940,117, PUB. 1-18-2011. INT. CL. 35.

BATIZ GREENHOUSES INC., SAN DIEGO, CA:  
2,865,570, CANC. INT. CL. 31.

BATTELLE FOR KIDS, COLUMBUS, OH:  
3,942,001, INT. CL. 42.

BAVARIAN CATERING CO., INC., CHARLOTTE, NC:  
2,368,215, CANC. INT. CL. 35.

BAY AREA COMPLIANCE LABORATORIES CORP., SUNNYVALE, CA:  
3,939,375, PUB. 1-18-2011. U.S. CL. A.

BAY AREA REAL ESTATE INFORMATION SERVICES, INC., SANTA ROSA, CA:  
3,939,441, PUB. 1-18-2011. MULTIPLE CLASS, INT. CLS. 41 AND 42.

BAYER HEALTHCARE LLC, PITTSBURGH, PA:  
2,865,017, CANC. INT. CL. 10.

BAYERISCHE MOTOREN WERKE AKTIENGESELLSCHAFT, FED REP GERMANY:  
3,940,066, PUB. 1-18-2011. INT. CL. 12.

BC INTERNATIONAL COSMETIC & IMAGE SERVICES, INC., ORLANDO, FL:  
3,940,765, PUB. 1-18-2011. INT. CL. 35.

BCD HOLDINGS N.V., WILLEMSTAD - CURAÇAO, NETHERLANDS ANTILLES:  
3,939,923, PUB. 1-18-2011. MULTIPLE CLASS, INT. CLS. 36, 39 AND 43.

BDI PHARMA, INC., COLUMBIA, SC:  
3,941,387, MULTIPLE CLASS, INT. CLS. 35 AND 41.  
3,941,388, MULTIPLE CLASS, INT. CLS. 35 AND 41.  
3,941,389, MULTIPLE CLASS, INT. CLS. 35 AND 41.

BEACH COMPANY, THE, CHARLESTON, SC:  
2,865,484, CANC. MULTIPLE CLASS, INT. CLS. 36, 37 AND 42.

BEACH COVE RESORT, INC., NORTH MYRTLE BEACH, SC:  
3,862,987, COR. INT. CL. 43.

BEACON LOOMS, INC., TEANECK, NJ:  
3,941,789, INT. CL. 24.

BEAMPINES, INC., NEW YORK, NY:  
3,940,515, PUB. 1-18-2011. INT. CL. 35.

BEARDSWORTH CONSULTING GROUP, INC., FLEMINGTON, NJ:  
3,942,181, INT. CL. 42.

BEAUTE CREATEURS (SOCIETE ANONYME), PARIS, FRANCE:  
2,864,995, CANC. INT. CL. 3.  
2,865,008, CANC. INT. CL. 3.  
2,865,013, CANC. INT. CL. 3.

BEAUTY ELEMENTS CORP., MIAMI GARDENS, FL:  
3,940,714, PUB. 1-18-2011. INT. CL. 26.  
3,940,716, PUB. 1-18-2011. INT. CL. 26.  
3,940,719, PUB. 1-18-2011. INT. CL. 26.

BEAUTYBANK INC., NEW YORK, NY:  
3,136,649, CANC. INT. CL. 3.

BECKER'S JEWELRY CORP., WEST HARTFORD, CT:  
2,865,427, CANC. INT. CL. 35.

BEEHIVE BOTANICALS, INC., HAYWARD, WI:  
3,939,762, PUB. 1-18-2011. INT. CL. 5.

BEHAVIOR ANALYST CERTIFICATION BOARD, INC., TALLAHASSEE, FL:  
2,408,451. REN. 3-3-11. INT. CL. 42.

BEHAVIORAL SCIENCE TECHNOLOGY, INC., OJAI, CA:  
1,630,419. REN. 3-1-11. INT. CL. 42.

BEHINDTHECHAIR.COM, LLC, ROSELLE, IL:  
3,942,021, INT. CL. 44.

BELL SPORTS, INC., SCOTTS VALLEY, CA:  
2,369,065, CANC. INT. CL. 14.

BELLA SOL FOODS, INC., GLENDALE, CA:  
3,941,602, INT. CL. 30.

- BELLACINO'S, INC., PORTAGE, MI:  
2,864,619, CANC. INT. CL. 43.
- BELLOTI, RAUL J, MAR DEI PLATA, ARGENTINA:  
2,416,672, REN. 3-3-11. INT. CL. 29.
- BELOVED BEASTS, LLC, THORNTON, CO:  
3,942,150, INT. CL. 5.
- BELTONE NETHERLANDS B.V., 5652 AL EINDHOVEN,  
NETHERLANDS:  
2,864,107, CANC. INT. CL. 10.
- BEN-BASSAT, JACKY, ATLANTA, GA:  
3,939,547, PUB. 1-18-2011. INT. CL. 28.
- BENCH DOG TOOLS, INC., 55340, MN:  
2,496,797, CANC. INT. CL. 8.
- BENCHMARK INDUSTRIES, INC., OLATHE, KS:  
2,368,779, CANC. INT. CL. 35.
- BENEFITS GROUP, INC., THE, LOS ANGELES, CA:  
2,368,157, CANC. INT. CL. 35.
- BENEQ OY, FINLAND:  
3,939,916, PUB. 1-18-2011. MULTIPLE CLASS, INT. CLS. 7  
AND 9.
- BENNETT, JASON A., YUCAIPA, CA:  
2,865,663, CANC. INT. CL. 37.
- BENNIGAN'S IP, LLC, DALLAS, TX:  
3,940,502, PUB. 1-18-2011. INT. CL. 30.  
3,940,504, PUB. 1-18-2011. INT. CL. 30.  
3,940,720, PUB. 1-18-2011. INT. CL. 29.  
3,941,741, INT. CL. 43.
- BENSON, TERRENCE, MT. HOLLY, NJ:  
2,865,810, CANC. INT. CL. 25.
- BENUSIS, LARA, LIC, NY:  
3,940,699, PUB. 1-18-2011. INT. CL. 41.
- BERG, JON, LA QUINTA, CA, DBA HELIX DISC GOLF:  
3,940,460, PUB. 1-18-2011. INT. CL. 35.
- BERG, JULIE, FRANKLIN, TN:  
2,369,432, CANC. INT. CL. 41.
- BERG, SEAN R., BALTIMORE, MD:  
2,865,207, CANC. INT. CL. 25.
- BERKSHIRE SERVICES LLC, MELBOURNE, FL:  
3,940,610, PUB. 1-18-2011. INT. CL. 35.
- BERNHAUT, JUSTIN M, LOS ANGELES, CA, TA JACK-  
ANDJILLKIDS.COM:  
3,940,604, PUB. 1-18-2011. INT. CL. 3.
- BERNINA INTERNATIONAL AG, STECKBORN, SWITZER-  
LAND:  
2,408,358, REN. 3-1-11. MULTIPLE CLASS, INT. CLS. 7  
AND 9.
- BERRY PLASTICS CORPORATION, EVANSVILLE, IN:  
2,428,649, REN. 3-2-11. INT. CL. 20.
- BERT ALFALFA CORPORATION, LARNED, KS TO BERT  
AND WETTA LARNED, INC., LARNED, KS:  
1,528,518, CANC. INT. CL. 31.
- BERTONI, ITALO, WINDSOR, CANADA:  
3,941,073, MULTIPLE CLASS, INT. CLS. 6, 7 AND 20.
- BEST WEB HOST, INCORPORATED, PHOENIX, AZ:  
2,441,687, REN. 2-25-11. INT. CL. 42.  
2,441,688, REN. 2-25-11. INT. CL. 42.
- BEST, STEVEN JAMES, VACAVILLE, CA:  
3,941,836, INT. CL. 25.
- BETHESDA SOFTWARES LLC, ROCKVILLE, MD:  
3,941,896, INT. CL. 9.
- BETTER SOILS, INC., GRAFTON, WI:  
2,498,926, CANC. MULTIPLE CLASS, INT. CLS. 1 AND 5.
- BETTS, KELLY, KINGS PARK, NY:  
2,865,363, CANC. INT. CL. 28.  
2,865,364, CANC. INT. CL. 28.
- BEZOOM USA, LLC, ARLINGTON, VA:  
3,941,296, INT. CL. 35.
- BFS BRANDS, LLC, NASHVILLE, TN:  
2,369,216, CANC. INT. CL. 12.
- BG MEDICINE, INC., WALTHAM, MA:  
3,939,842, PUB. 1-18-2011. INT. CL. 5.  
3,939,859, PUB. 1-18-2011. INT. CL. 5.
- BHI ADVANCED INTERNET, EDEN PRAIRIE, MN:  
3,940,378, PUB. 1-18-2011. INT. CL. 42.
- BIAS, WILLIAM H., BOSTON, MA:  
2,476,238, CANC. INT. CL. 25.
- BIBLICA, INC., COLORADO SPRINGS, CO:  
1,645,177, REN. 2-28-11. INT. CL. 16.
- BID MOTORS LLC, CLARKSTON, MI:  
3,940,419, PUB. 1-18-2011. INT. CL. 35.
- BIDDING BUZZ GLOBAL LIMITED, BURLEIGH HEADS,  
AUSTRALIA:  
3,939,925, PUB. 1-18-2011. MULTIPLE CLASS, INT. CLS.  
9, 16, 35 AND 41.
- BIENES RAICES METROPOLITANOS, S.A. DE C.V., MEX-  
ICO CITY D.F., MEXICO:  
2,865,453, CANC. INT. CL. 32.
- BIERMANN PRODUCTIONS LLC, WICHITA, KS:  
3,942,053, INT. CL. 41.
- BIG APPLE ANIME FEST CORPORATION, NEW YORK,  
NY:  
2,864,323, CANC. INT. CL. 41.
- BIG BALLS GOLF, LLC, OLYMPIA, WA:  
3,941,521, INT. CL. 28.
- BIG BANG PRODUCTIONS LLC, BOULDER, CO:  
3,941,477, MULTIPLE CLASS, INT. CLS. 9, 16 AND 41.
- BIG BOY RESTAURANTS INTERNATIONAL LLC, WAR-  
REN, MI, DBA ELIAS BROTHERS RESTAURANTS,  
MARRIOTT CORPORATION, WASHINGTON, DC:  
1,166,686, REN. 2-25-11. INT. CL. 29.
- BIG BROTHERS-BIG SISTERS OF AMERICA, PHILADEL-  
PHIA, PA:  
2,368,043, CANC. INT. CL. 42.
- BIG IDEA ENTERTAINMENT, LLC, NEW YORK, NY:  
3,941,248, INT. CL. 16.
- BIG PAPER AMERICA INC, TORONTO, ONTARIO, CANA-  
DA:  
2,865,134, CANC. INT. CL. 16.
- BIG TIME HOLDINGS, INC., ROME, GA:  
3,941,819, INT. CL. 21.  
3,941,820, INT. CL. 21.
- BIG TIME MARKETING, INC., ATLANTA, GA:  
2,540,723, REN. 2-26-11. INT. CL. 32.
- BIGELOW AEROSPACE, LLC, LAS VEGAS, NV:  
3,939,354, PUB. 1-18-2011. INT. CL. 42.
- BIGELOW MANAGEMENT, INC., LAS VEGAS, NV:  
3,939,353, PUB. 1-18-2011. INT. CL. 43.  
3,939,357, PUB. 1-18-2011. INT. CL. 43.
- BILKO ILAC KOZMETİK VE KIMYA SANAYİ VE TİCARET  
ANONİM ŞİRKETİ, KUCUKCEKMECE-ISTANBUL, TUR-  
KEY:  
2,864,090, CANC. INT. CL. 3.
- BILLION INTERNATIONAL TRADING, INC., SOUTH EL  
MONTE, CA:  
3,942,457, INT. CL. 25.
- BIO-DERM LABORATORIES, INC., LONGVIEW, TX:  
2,447,108, REN. 2-26-11. INT. CL. 3.
- BIOANALYTICAL SYSTEMS, INC., WEST LAFAYETTE, IN:  
2,431,031, REN. 2-26-11. INT. CL. 9.
- BIOCARE LABS, INC., BEDFORD PARK, IL:  
2,865,376, CANC. INT. CL. 3.  
2,865,492, CANC. INT. CL. 3.  
3,776,945, COR. INT. CL. 3.
- BIOGAS ENERGY SYSTEMS AND TECHNOLOGY LLC,  
TUSCALOOSA, AL:  
3,939,795, PUB. 1-18-2011. INT. CL. 42.
- BIOLA UNIVERSITY, INC., LA MIRADA, CA:  
2,524,203, REN. 2-26-11. INT. CL. 42.
- BIOLAB (AUST) PTY LTD, SYDNEY NSW 2000, AUSTRA-  
LIA, DATATAKER, INC., LAGUNA HILLS, CA:  
2,497,542, REN. 3-2-11. INT. CL. 9.
- BIOMAREX LIMITED, DUNEDIN, NEW ZEALAND:  
3,939,766, PUB. 1-18-2011. MULTIPLE CLASS, INT. CLS. 5  
AND 29.
- BIOPELLE, INC., FERNDALE, MI:  
3,939,829, PUB. 1-18-2011. INT. CL. 3.
- BIOPRODUCTS, INC., WARRENTON, OR TO MOORE-  
CLARK U.S.A., INC., VANCOUVER, BRITISH COLUM-  
BIA, CANADA:  
2,072,301, CANC. INT. CL. 1.
- BIOSAFE MEDICAL TECHNOLOGIES, INC., LAKE FOR-  
EST, IL:  
2,865,454, CANC. MULTIPLE CLASS, INT. CLS. 10 AND  
42.
- BIP GMBH, AUSTRIA:  
3,939,977, PUB. 1-18-2011. MULTIPLE CLASS, INT. CLS.

- 1, 17 AND 19.  
**BIRD & CRONIN, INC.**, EAGAN, MN:  
 2,448,285. REN. 2-26-11. INT. CL. 10.  
**BIRDQUEST, L.L.C.**, HOUSTON, TX:  
 3,942,329, MULTIPLE CLASS, INT. CLS. 39 AND 41.  
**BIRDS EYE FOODS, INC.**, ROCHESTER, NY:  
 2,865,801, CANC. INT. CL. 29.  
**BISON BREWING COMPANY, LLC**, BERKELEY, CA:  
 3,939,347, PUB. 1-18-2011. MULTIPLE CLASS, INT. CLS.  
 32 AND 33.  
**BISSELL HOMECARE, INC.**, GRAND RAPIDS, MI:  
 3,941,204, INT. CL. 5.  
**BITAR, PETE, ANDERSON, IN:**  
 3,939,689, PUB. 1-18-2011. INT. CL. 42.  
**BITZ & PIXELZ BV**, AMSTERDAM, NETHERLANDS:  
 3,940,360, PUB. 1-18-2011. INT. CL. 9.  
**BIZILLA.COM, LLC**, MIDLOTHIAN, VA:  
 3,942,291, INT. CL. 42.  
**BLACK BERETS DEFENSE & FITNESS ACADEMY, L.L.C.**,  
 MILFORD, MI:  
 3,940,280, PUB. 1-18-2011. MULTIPLE CLASS, INT. CLS.  
 25 AND 41.  
**BLACK FIVES, INC.**, GREENWICH, CT:  
 2,865,651, CANC. INT. CL. 25.  
**BLACK LEGENDS OF PROFESSIONAL BASKETBALL**  
**FOUNDATION, DETROIT, MI:**  
 2,369,080, CANC. MULTIPLE CLASS, INT. CLS. 25 AND  
 41.  
**BLACK MOR, LLC**, MERIDIAN, ID:  
 3,941,169, INT. CL. 41.  
**BLACK, ANDREW, SAN JOSE, CA:**  
 3,939,777, PUB. 1-18-2011. MULTIPLE CLASS, INT. CLS.  
 9, 35 AND 41.  
**BLACKFIN FRANCHISING, LLC**, LITTLETON, CO:  
 3,941,467, MULTIPLE CLASS, INT. CLS. 35 AND 45.  
 3,941,470, MULTIPLE CLASS, INT. CLS. 35 AND 45.  
**BLACKROCK INSTITUTIONAL TRUST COMPANY, NA-**  
**TIONAL ASSOCIATION, SAN FRANCISCO, CA:**  
 2,368,836, CANC. INT. CL. 36.  
 2,865,514, CANC. INT. CL. 36.  
**BLACKSMITH BRANDS, INC.**, IRVINGTON, NY:  
 3,941,171, INT. CL. 5.  
**BLAIN SUPPLY, INC.**, JANESVILLE, WI:  
 3,939,604, PUB. 5-18-2010. INT. CL. 35.  
**BLASCH PRECISION CERAMICS, INC.**, ALBANY, NY:  
 3,940,438, PUB. 1-18-2011. INT. CL. 1.  
**BLEEDING EDGE MUSIC INC.**, KINGWOOD, TX:  
 2,611,479, CANC. INT. CL. 35.  
**BLESSING, DOUGLAS P.**, GILROY, CA:  
 3,450,911, CANC. MULTIPLE CLASS, INT. CLS. 25, 38  
 AND 41.  
 3,464,016, CANC. MULTIPLE CLASS, INT. CLS. 25, 38  
 AND 41.  
**BLIND HORSE KNIVES PARTNERSHIP, STEUBENVILLE,**  
**OH:**  
 3,940,794, PUB. 1-18-2011. INT. CL. 8.  
**BLINK MUSIC, INC.**, CAMBRIDGE, MA:  
 2,588,355, CANC. INT. CL. 35.  
 2,626,982, CANC. INT. CL. 41.  
**BLISS WORLD LLC**, NEW YORK, NY:  
 2,865,416, CANC. INT. CL. 42.  
**BLIZZARD ENTERTAINMENT, INC.**, IRVINE, CA:  
 2,865,169, CANC. INT. CL. 28.  
**BLOCK DRUG COMPANY, INC.**, WEST TRENTON, NJ:  
 3,941,318, INT. CL. 5.  
**BLOCKER, ADAM P.**, CHAPEL HILL, NC:  
 3,940,343, PUB. 1-18-2011. INT. CL. 35.  
**BLOGINSONG LLC**, LAKEWOOD, CO:  
 3,939,631, PUB. 1-18-2011. INT. CL. 9.  
**BLOHM JUNG GMBH**, HAMBURG, FED REP GERMANY,  
**BLOHM, ROBERT**, HAMBURG-BERGENDORF, FED REP  
 GERMANY:  
 910,007. REN. 3-2-11. U.S. CL. 23 (INT. CL. 7).  
**BLUE AVOCADO, INC.**, AUSTIN, TX:  
 3,940,426, PUB. 1-18-2011. INT. CL. 18.  
**BLUE CARE CO.,LTD**, REPUBLIC OF KOREA:  
 3,940,057, PUB. 1-18-2011. INT. CL. 11.  
**BLUE GULF INDUSTRIAL SUPPLY COMPANY, NEWARK,**  
**DE:**  
 2,865,419, CANC. INT. CL. 3.  
**BLUE HERON NURSERIES, LLC.**, WINTER GARDEN, FL:  
 3,942,160, INT. CL. 44.  
**BLUE MARBLE NETWORK, LLC**, SEATTLE, WA:  
 3,942,023, MULTIPLE CLASS, INT. CLS. 38 AND 42.  
 3,942,031, MULTIPLE CLASS, INT. CLS. 38 AND 42.  
**BLUE RIBBON PET PRODUCTS, INC.**, COMMACK, NY:  
 2,521,621. REN. 2-26-11. INT. CL. 35.  
**BLUE SKY ENTERPRISES, INC.**, LACONIA, NH:  
 2,539,497. REN. 2-26-11. INT. CL. 36.  
**BLUEJAY HANKINS, TONASKET, WA:**  
 3,942,370, INT. CL. 41.  
**BLUFIN S.P.A.**, CARPI, ITALY:  
 3,940,982, MULTIPLE CLASS, INT. CLS. 18 AND 25.  
**BLX GROUP LLC**, LOS ANGELES, CA:  
 3,942,199, INT. CL. 42.  
**BMB CLOTHING LIMITED**, LEEDS, UNITED KINGDOM,  
**JOSEPH AND FEISS COMPANY, THE**, CLEVELAND, OH:  
 1,646,493. REN. 2-25-11. INT. CL. 25.  
**BMC SOFTWARE, INC.**, HOUSTON, TX:  
 2,427,989. REN. 2-26-11. INT. CL. 9.  
**BMD LEADERSHIP INSTITUTE, INC.**, AUBURN, NY:  
 3,940,526, PUB. 1-18-2011. INT. CL. 41.  
**BMM INTERNATIONAL PTY LTD.**, BOX HILL, VICTORIA,  
 AUSTRALIA:  
 2,865,383, CANC. INT. CL. 42.  
**BNG ENTERPRISES, INC.**, PHOENIX, AZ:  
 2,539,154. REN. 3-2-11. INT. CL. 5.  
**BNG ENTERPRISES, INC.**, TEMPE, AZ:  
 2,865,430, CANC. INT. CL. 5.  
**BNP MEDIA II, LLC**, TROY, MI:  
 2,432,816. REN. 3-3-11. MULTIPLE CLASS, INT. CLS. 16  
 AND 35.  
**BOARD & BATTEN INTERNATIONAL INC.**, GEORGE-  
 TOWN, CAYMAN ISLANDS:  
 3,862,683, COR. INT. CL. 20.  
**BOARD OF REGENTS OF THE UNIVERSITY SYSTEM OF**  
**GEORGIA**, ATLANTA, GA:  
 3,941,425, MULTIPLE CLASS, INT. CLS. 16, 36 AND 41.  
**BOARD OF REGENTS, THE UNIVERSITY OF TEXAS**  
**SYSTEM**, AUSTIN, TX:  
 2,517,149. REN. 2-26-11. INT. CL. 25.  
**BOARD OF TRUSTEES OF THE UNIVERSITY OF ARKAN-**  
**SAS**, LITTLE ROCK, AR:  
 3,940,278, PUB. 1-18-2011. INT. CL. 41.  
**BOAZ AND RUTH, INC.**, RICHMOND, VA:  
 3,940,586, PUB. 1-18-2011. INT. CL. 41.  
**BOB'S BETTER BEEF, INC**, SOUTH ELGIN, IL:  
 3,939,365, PUB. 1-18-2011. INT. CL. 25.  
**BOB'S STORES CORP.**, MERIDEN, CT:  
 3,940,506, PUB. 1-18-2011. INT. CL. 35.  
**BOCCALONE, LLC**, OAKLAND, CA, DBA BOCCALONE:  
 3,940,112, PUB. 1-18-2011. INT. CL. 29.  
**BODELL, SHERI**, LOS ANGELES, CA:  
 3,941,656, INT. CL. 25.  
**BODYONICS, LTD.**, HICKSVILLE, NY:  
 2,865,137, CANC. INT. CL. 5.  
**BOEHRINGER INGELHEIM INTERNATIONAL GMBH, IN-**  
**GELHEIM, FED REP GERMANY:**  
 3,940,708, PUB. 1-18-2011. INT. CL. 5.  
 3,940,711, PUB. 1-18-2011. INT. CL. 5.  
 3,940,713, PUB. 1-18-2011. INT. CL. 5.  
 3,940,718, PUB. 1-18-2011. INT. CL. 5.  
**BOEHRINGER INGELHEIM VETMEDICA GMBH**, 55216  
 INGELHEIM AM RHEIN, FED REP GERMANY:  
 2,429,487. REN. 3-2-11. INT. CL. 5.  
**BOEING MANAGEMENT COMPANY**, SEAL BEACH, CA,  
**BOEING MANAGEMENT COMPANY**, SEAL BEACH, CA:  
 2,460,236. REN. 2-26-11. INT. CL. 28.  
**BOEWE TEXTILE CLEANING USA INC.**, DALLAS, TX:  
 2,368,552, CANC. INT. CL. 35.  
**BOHBOT, MARC**, LOS ANGELES, CA AND BOHBOT,  
 MICHELE, LOS ANGELES, CA:  
 2,864,789, CANC. INT. CL. 25.  
**BOHEMIA NURSERY LLC**, WEST OLIVE, MI:  
 3,941,534, INT. CL. 31.

- BOHNING COMPANY, LTD., THE, LAKE CITY, MI:  
3,942,115, INT. CL. 35.
- BOI PROMOTIONS INC., NEW YORK, NY:  
3,940,550, PUB. 1-18-2011. INT. CL. 41.
- BOISE CASCADE, L.L.C., BOISE, ID:  
1,183,781. REN. 2-26-11. INT. CL. 19.
- BOMART BY OWNER, INC., PORT RICHEY, FL:  
2,864,903, CANC. INT. CL. 35.
- BOMBARDIER RECREATIONAL PRODUCTS INC., VAL-COURT, QUEBEC, CANADA:  
3,939,465, PUB. 1-18-2011. INT. CL. 12.
- BON PRIX HANDELSGESELLSCHAFT MBH, 22179, HAMBURG, FED REP GERMANY:  
2,864,524, CANC. MULTIPLE CLASS, INT. CLS. 16 AND 25.
- BON TON LICENSING BV, CURACAO, NETHERLANDS ANTILLES:  
3,940,041, PUB. 1-18-2011. INT. CL. 30.
- BOND LABORATORIES, INC., OMAHA, NE:  
3,940,778, PUB. 1-18-2011. INT. CL. 5.
- BOND, ROBERT J. JR., PEWEE VALLEY, KY:  
2,864,646, CANC. INT. CL. 37.
- BONNEVILLE ENVIRONMENTAL FOUNDATION, PORTLAND, OR:  
3,941,236, INT. CL. 36.
- BONNIE'S BALMS INC., WHEAT RIDGE, CO, AKA BONNIE'S BALMS INC. AND RICHARD SQUIRE, WHEAT RIDGE, CO:  
3,942,400, INT. CL. 5.
- BOOKS AND COOKIES, VENICE, CA:  
3,940,302, PUB. 1-18-2011. INT. CL. 35.
- BOOKSOURCE, INC., THE, ST. LOUIS, MO:  
3,942,305, INT. CL. 28.
- BOOMERDOLLS, LLC, PHOENIX, AZ:  
3,941,286, MULTIPLE CLASS, INT. CLS. 5 AND 35.  
3,941,287, MULTIPLE CLASS, INT. CLS. 5 AND 35.
- BOOT BARN, INC., ORANGE, CA:  
3,941,630, MULTIPLE CLASS, INT. CLS. 25 AND 35.
- BOOTH, WILLIAM YORK, SANTA MONICA, CA, DBA ROPE-AEROBICS INTERNATIONAL:  
1,636,381. REN. 3-2-11. INT. CL. 41.
- BORDIGIONI FAMILY WINERY, LLC, SANTA ROSA, CA:  
3,940,383, PUB. 1-18-2011. INT. CL. 33.
- BORELLY'S, INC., MOBILE, AL:  
3,939,598, PUB. 1-18-2011. INT. CL. 14.  
3,939,599, PUB. 1-18-2011. INT. CL. 14.
- BORISKIE, HELEN ANN, ALPHARETTA, GA, DBA BRAIN INJURY PEER VISITOR ASSOCIATION:  
3,940,078, PUB. 1-18-2011. INT. CL. 35.
- BOSE CORPORATION, FRAMINGHAM, MA:  
2,863,985, CANC. INT. CL. 35.  
3,940,522, PUB. 1-18-2011. INT. CL. 12.
- BOSTON CENTERLESS, INC., WOBURN, MA:  
1,639,509. REN. 3-3-11. INT. CL. 6.
- BOSTON CLUB CO., LTD., SABAE-SHI, FUKUI-KEN, JAPAN:  
2,432,118. REN. 2-26-11. INT. CL. 9.
- BOTKIN, STEVE, ANAHEIM, CA:  
2,864,751, CANC. INT. CL. 43.
- BOTTOMLEY, STEPHEN, CAMBS, ENGLAND:  
2,388,741. REN. 3-3-11. INT. CL. 35.
- BOUJU DERAMBURE BUGNION, PARIS, FRANCE:  
2,864,500, CANC. INT. CL. 42.
- BOUTINOT LIMITED, GATLEY, CHESHIRE, UNITED KINGDOM:  
2,865,431, CANC. INT. CL. 33.
- BOWMAN, ERIK, REDONDO BEACH, CA:  
3,941,885, INT. CL. 35.
- BOWMAN, THERESA CLARE, MYAREE B/C MYAREE 6960, AUSTRALIA:  
3,940,385, PUB. 1-18-2011. INT. CL. 41.
- BOY SCOUTS OF AMERICA, THE, IRVING, TX:  
2,425,635. REN. 3-1-11. INT. CL. 41.
- BOYD BYERLY, INC., SAN ANTONIO, TX, DBA ACCREDITED MORTGAGE SERVICES:  
2,865,237, CANC. INT. CL. 36.
- BOYLE, BRENDAN, MONTE RIO, CA:  
3,941,845, INT. CL. 9.
- BP MEDIA CONCEPTS, LLC, WOODBRIDGE, CT:  
3,941,239, INT. CL. 35.
- BRABBINS, STEPHEN WRAY, BINGLEY, UNITED KINGDOM:  
2,865,030, CANC. INT. CL. 9.
- BRADEN, MICHAEL T., CHANDLER, AZ:  
3,940,988, INT. CL. 32.
- BRADFORD COMPANY, HOLLAND, MI:  
1,636,896. REN. 3-2-11. INT. CL. 16.
- BRADY TRADEMARK, LLC, WILMINGTON, DE:  
2,865,352, CANC. MULTIPLE CLASS, INT. CLS. 39 AND 42.
- BRADY WORLDWIDE, INC., MILWAUKEE, WI:  
2,864,766, CANC. MULTIPLE CLASS, INT. CLS. 16 AND 20.
- BRADY, KEVIN DOUGLAS, JONESBORO, AR:  
3,942,458, INT. CL. 7.
- BRAEBURN SYSTEMS LLC, MONTGOMERY, IL:  
3,940,268, PUB. 1-18-2011. MULTIPLE CLASS, INT. CLS. 9 AND 11.
- BRAINDISTRICT GMBH, FED REP GERMANY:  
3,939,990, PUB. 1-18-2011. MULTIPLE CLASS, INT. CLS. 9 AND 42.
- BRAMTON COMPANY, THE, IRVING, TX:  
2,436,167. REN. 2-26-11. MULTIPLE CLASS, INT. CLS. 3 AND 5.
- BRANCH PROPERTIES, LLC, ATLANTA, GA:  
3,940,561, PUB. 1-18-2011. MULTIPLE CLASS, INT. CLS. 36 AND 37.
- BRAND.NET, INC., SAN MATEO, CA:  
3,942,430, INT. CL. 35.
- BRANDS, THOMAS N., IOWA CITY, IA:  
2,430,006. REN. 2-26-11. INT. CL. 41.
- BRASWELL MILLING COMPANY, NASHVILLE, NC:  
2,439,128. REN. 3-3-11. INT. CL. 31.
- BRAV-WURLD, LLC, RENO, NV:  
3,941,191, MULTIPLE CLASS, INT. CLS. 11 AND 42.
- BRAZILIAN CHAMELEON, INC., OKLAHOMA CITY, OK:  
2,865,504, CANC. MULTIPLE CLASS, INT. CLS. 25 AND 35.
- BREAKALL, STACEY L., AUSTIN, TX:  
2,865,268, CANC. INT. CL. 41.
- BREAKTHROUGH ENTERPRISES, INC., RAPID CITY, SD:  
2,865,822, CANC. INT. CL. 42.
- BREG, INC., VISTA, CA:  
2,445,909. REN. 3-3-11. INT. CL. 10.
- BREMENN IP HOLDINGS, LLC, CARSON CITY, NV:  
3,941,240, INT. CL. 3.
- BRENDLEN, JAYLYN, SANTA CRUZ, CA:  
3,941,459, INT. CL. 25.
- BRENNTAG HOLDING GMBH, FED REP GERMANY:  
3,939,981, PUB. 1-18-2011. MULTIPLE CLASS, INT. CLS. 1, 2, 3, 4, 37, 39, 40 AND 42.
- BRENTON, INC., HENDERSON, GA, BRENTON, INC., HENDERSON, GA:  
2,429,579. REN. 2-25-11. INT. CL. 30.
- BRENTON, INC., HENDERSON, KY, BRENTON, INC., HENDERSON, KY:  
2,429,580. REN. 2-25-11. INT. CL. 30.
- BRENTON, INC., STOCKBRIDGE, GA, BRENTON, INC., STOCKBRIDGE, GA:  
2,429,582. REN. 3-3-11. INT. CL. 30.
- BRENTWOOD INDUSTRIES, INC., READING, PA:  
2,368,542, CANC. INT. CL. 12.
- BRENVA INSTITUTE, INC., COLORADO SPRINGS, CO:  
2,865,505, CANC. MULTIPLE CLASS, INT. CLS. 16 AND 35.
- BRETT BAUGHMAN, ENCINITAS, CA:  
3,940,183, PUB. 1-18-2011. INT. CL. 41.
- BREYNER, VIENNE, FRANCE:  
3,940,238, PUB. 1-18-2011. MULTIPLE CLASS, INT. CLS. 1 AND 40.
- 3,940,240, PUB. 1-18-2011. MULTIPLE CLASS, INT. CLS. 1 AND 40.
- BRIAN GROOVER, GARDEN GROVE, CA, DBA GROOVER CLOTHING:  
3,941,424, INT. CL. 25.

BRIAN OWENS, LONDON, GREAT BRITAIN AND KARIN MUCCI, LONDON, GREAT BRITAIN:  
3,939,455, PUB. 1-18-2011. INT. CL. 32.

BRIDGEPOINT SYSTEMS, INC., OAKLAND, CA:  
2,864,304, CANC. INT. CL. 36.

BRIDGESTONE BRANDS, LLC, NASHVILLE, TN:  
2,368,866, CANC. INT. CL. 12.  
2,541,273, REN. 3-3-11. INT. CL. 12.

BRIDGEWATER SYSTEMS CORPORATION, OTTAWA, ONTARIO, CANADA:  
3,941,044, MULTIPLE CLASS, INT. CLS. 9, 37 AND 42.

BRIDGEWATER SYSTEMS CORPORATION, OTTAWA, CANADA:  
3,941,045, MULTIPLE CLASS, INT. CLS. 9, 37 AND 42.

BRIGADOON VINEYARD, LLC, EUGENE, OR:  
3,941,276, INT. CL. 33.

BRIGGS AND STRATTON CORPORATION, WAUWATOSA, WI:  
3,941,080, INT. CL. 7.

BRIGHT HOUSE NETWORKS LLC, EAST SYRACUSE, NY:  
2,864,479, CANC. INT. CL. 35.

BRIGHTON CROMWELL LLC, RANDOLPH, NJ:  
3,941,557, MULTIPLE CLASS, INT. CLS. 35 AND 39.  
3,941,558, MULTIPLE CLASS, INT. CLS. 35 AND 39.

BRIK, INC., BUTLER, PA:  
2,368,799, CANC. INT. CL. 42.

BRILLIANT SPIRIT LIMITED, DUBLIN, IRELAND:  
2,477,005, REN. 2-26-11. INT. CL. 33.

BRISTOL-MYERS SQUIBB COMPANY, NEW YORK, NY:  
2,430,282, REN. 2-26-11. INT. CL. 41.

BRITA LP, NEUCHÂTEL, SWITZERLAND:  
3,941,468, INT. CL. 21.

BRITE-LINE TECHNOLOGIES, LLC, CANTON, MA:  
3,939,458, PUB. 1-18-2011. INT. CL. 17.

BROADCASTING OF PUERTO RICO, INC., GUAYNABO, PUERTO RICO:  
2,547,201, CANC. INT. CL. 38.

BROCKSCHMIDT, WILLIAM R. JR., WASHINGTON, DC, AKA BRENT ROBERTS:  
2,865,045, CANC. INT. CL. 9.

BROOKE KALANICK, NEW YORK, NY:  
3,941,428, MULTIPLE CLASS, INT. CLS. 41 AND 44.

BROOKER, ERIC, LAS VEGAS, NV:  
3,940,633, PUB. 1-18-2011. INT. CL. 9.

BROSS, RICHARD A., HOLLIS, NH, DBA SILVERSPORE-COM:  
3,941,768, INT. CL. 42.

BROTHER, THEODORE B., NORTH ANDOVER, MA:  
2,864,881, CANC. INT. CL. 28.

BROWN & BROWN OF CALIFORNIA, INC., TAMPA, FL:  
3,940,272, PUB. 1-18-2011. INT. CL. 36.

BROWN & BROWN OF WASHINGTON, INC., TAMPA, FL:  
3,940,307, PUB. 1-18-2011. INT. CL. 36.

BROWN DAILY HERALD, INC., THE, PROVIDENCE, RI:  
2,500,394, REN. 3-1-11. INT. CL. 16.

BROWN INNOVATION GROUP, INC., SALT LAKE CITY, UT:  
3,942,365, INT. CL. 8.

BROWN LITTLE, DANIEL C., BIRMINGHAM, AL:  
2,865,261, CANC. INT. CL. 35.

BROWN REALTY ADVISORS, INC., ATLANTA, GA:  
2,864,623, CANC. INT. CL. 36.

BROWN SHOE COMPANY, INC., ST. LOUIS, MO:  
2,024,206, CANC. INT. CL. 25.

BROWN, HOWARD J. GUILFORD, CT:  
3,941,894, INT. CL. 42.

BROWN, JACOB P., NASHVILLE, TN:  
3,939,684, PUB. 1-18-2011. INT. CL. 16.

BRS CONNECT MEDIEN- UND; SYSTEMTECHNIK GMBH, FED REP GERMANY:  
3,940,013, PUB. 1-18-2011. INT. CL. 9.

BRUCKMAN, DAVID B., RYE BROOK, NY:  
3,808,242, CANC. MULTIPLE CLASS, INT. CLS. 35 AND 36.

BRUCKNER, DONNA, FREMONT, CA AND BRUCKNER, ALFRED, FREMONT, CA:  
2,865,563, CANC. INT. CL. 20.

BRUNER, ERWIN SANTOS, ROYAL PALM BEACH, FL:  
3,942,206, INT. CL. 26.

BRUNSWICK COMMERCIAL & GOVERNMENT PRODUCTS, INC., EDGEWATER, FL:  
2,685,730, CANC. INT. CL. 12.

BRUNTON INTERNATIONAL, INC., DALLAS, TX:  
2,863,924, CANC. INT. CL. 24.

BRYAN, MICHAEL V., LAFYETTE, IN:  
2,378,772, REN. 2-25-11. INT. CL. 3.

BRYANT UNIVERSITY, EXECUTIVE DEVELOPMENT CENTER, SMITHFIELD, RI:  
3,939,751, PUB. 1-18-2011. INT. CL. 41.

BRYNDANA INTERNATIONAL LTD, HAVERTOWN, PA:  
2,864,637, CANC. INT. CL. 2.

BSW BERLEBURGER SCHAUMSTOFFWERK GMBH, BAD BERLEBURG, FED REP GERMANY:  
3,845,651, COR. INT. CL. 19.

BTG INTERNATIONAL LIMITED, LONDON, UNITED KINGDOM:  
3,941,354, MULTIPLE CLASS, INT. CLS. 1 AND 5.

BTG TEST PREP, LLC, SAN MATEO, CA:  
3,940,101, PUB. 1-18-2011. INT. CL. 41.

BUBBA FOODS, LLC, JACKSONVILLE, FL:  
3,941,200, INT. CL. 43.

BUCK A DAY COMPANY, THE, NEW MARKET, ONTARIO, L3Y 2P1, CANADA:  
2,864,043, CANC. INT. CL. 36.

BUCK AND FILLY LIMITED, LONDON, UNITED KINGDOM:  
3,939,629, PUB. 1-18-2011. MULTIPLE CLASS, INT. CLS. 3, 9, 18, 21, 25 AND 35.

BUCK SNORT LODGE PRODUCTS, INC., MUSKEGON, MI:  
2,368,813, CANC. INT. CL. 6.

BUCK, ANTHONY A. COATESVILLE, PA:  
3,941,166, INT. CL. 9.

BUCKINGHAM ENTERPRIZES, INC., MOAB, UT:  
2,495,982, REN. 2-27-11. INT. CL. 42.

BUCKLEY, CHARISE M., FRISCO, CO:  
3,941,454, INT. CL. 20.

BUCKNER & COMPANY, INC., DALLAS, TX:  
3,939,383, PUB. 1-18-2011. INT. CL. 35.  
3,939,384, PUB. 1-18-2011. INT. CL. 35.

BUDDY'S ALUMINUM DEPOT, INC., LECANTO, FL:  
2,865,482, CANC. INT. CL. 6.

BUDERIM MACADAMIAS OF HAWAII, LLC, QUEENSLAND, AUSTRALIA:  
1,635,598, REN. 2-26-11. MULTIPLE CLASS, INT. CLS. 29 AND 30.

BUDGE INDUSTRIES LLC, LANSDALE, PA:  
1,630,671, REN. 2-25-11. INT. CL. 12.

BUDGET RENT A CAR SYSTEM, INC., PARSIPPANY, NJ:  
2,864,953, CANC. INT. CL. 35.

BUFLOVAK, LLC, BUFFALO, NY:  
2,368,881, CANC. INT. CL. 7.

BUG DOCTOR, INC., PARAMUS, NJ:  
2,731,720, CANC. INT. CL. 37.  
2,731,721, CANC. INT. CL. 37.

BUILDERLINK, LLC, SPRINGFIELD, OR:  
3,940,884, PUB. 1-18-2011. INT. CL. 35.  
3,940,888, PUB. 1-18-2011. INT. CL. 35.

BUILDING PRODUCTS OF CANADA CORP./ LA CIE MATERIAUX DE CONSTRUCTION BP CANADA, LALSALLE, QUEBEC, CANADA:  
3,939,563, PUB. 1-18-2011. INT. CL. 19.

BULLET LINE, LLC, MIAMI, FL:  
3,941,174, INT. CL. 35.

BULLSEYE S.D. LOCKS LLC, LEXINGTON, KY:  
3,939,378, PUB. 1-18-2011. INT. CL. 6.  
3,939,379, PUB. 1-18-2011. INT. CL. 6.

BUMBLE BEE FOODS, LLC, SAN DIEGO, CA:  
3,940,359, PUB. 1-18-2011. INT. CL. 41.

BUNN-O-MATIC CORPORATION, SPRINGFIELD, IL:  
3,941,533, INT. CL. 11.

BUOY, ROGER, SOMERSET, UNITED KINGDOM:  
3,941,098, INT. CL. 3.

BURGER KING CORPORATION, MIAMI, FL:  
2,428,846, REN. 2-25-11. INT. CL. 42.  
2,449,837, REN. 3-2-11. INT. CL. 28.

- BURKHART, ALAN KEITH, VAN BUREN, AR:  
3,941,084, INT. CL. 14.
- BURKHOLDER, BRITT LANG, CRESCENT MILLS, CA:  
2,487,654, REN. 2-26-11, INT. CL. 29.
- BURNHAM SERVICES, INC., WILMINGTON, DE:  
2,865,551, CANC. INT. CL. 11.
- BURRES, KENNETH P., MONTCLAIR, CA:  
2,863,953, CANC. INT. CL. 42.
- BURROUGHS, DAVID, EL PASO, IL:  
3,940,553, PUB. 1-18-2011, INT. CL. 41.
- BUSHKO, RENATA, HOPKINTON, MA:  
2,533,319, REN. 2-26-11, INT. CL. 41.
- BUSINESS OWNERS LIABILITY TEAM LLC, FARMINGTON, CT:  
3,941,837, INT. CL. 36.
- BUSINESS TRAVEL HOUNDS, LLC, OVIEDO, FL:  
3,940,564, PUB. 1-18-2011, INT. CL. 39.
- BUSY AND BLESSED, MARIETTA, GA:  
3,939,668, PUB. 1-18-2011, INT. CL. 40.
- BUTLER, INC., GARDENA, CA:  
2,369,290, CANC. INT. CL. 6.
- BUZZ MONKEY SOFTWARE, LLC, EUGENE, OR:  
3,942,279, MULTIPLE CLASS, INT. CLS. 9 AND 41.
- BW EQUINE PERFORMANCE, LLC, SHELBYVILLE, KY:  
3,940,573, PUB. 1-18-2011, INT. CL. 5.
- BYBEE, CLYDE, PROSSER, WA:  
3,939,380, PUB. 1-18-2011, INT. CL. 31.
- C. & J. CLARK INTERNATIONAL LIMITED, STREET, SOMERSET, UNITED KINGDOM:  
3,941,282, INT. CL. 25.
- C. R. BARD, INC., MURRAY HILL, NJ:  
2,451,756, REN. 3-2-11, INT. CL. 10.
- C.A.M.P.U.S. DEVELOPMENT GROUP, INCORPORATED, GAINESVILLE, FL:  
2,864,345, CANC. INT. CL. 36.
- C.B. FLEET COMPANY, INCORPORATED, LYNCHBURG, VA:  
2,864,540, CANC. INT. CL. 5.
- C.P. GAUGER CO., INC., WEST ALLIS, WI:  
2,407,132, REN. 3-1-11, MULTIPLE CLASS, INT. CLS. 35 AND 41.
- C.S.B. COMMODITIES, INC., WESTBURY, NY:  
3,940,656, PUB. 1-18-2011, INT. CL. 16.
- C-FORWARD, INC., FORT THOMAS, KY:  
2,684,230, CANC. INT. CL. 42.
- C-MEDIA ELECTRONICS INC., TAIPEI, TAIWAN:  
3,941,350, MULTIPLE CLASS, INT. CLS. 9 AND 42.
- CABEAU, INC., CANOGA PARK, CA:  
3,940,923, PUB. 1-18-2011, MULTIPLE CLASS, INT. CLS. 18, 20 AND 24.
- CABINTIGER STUDIO, INC., DADEVILLE, AL:  
3,941,503, INT. CL. 16.
- CABLEXPRESS CORPORATION, SYRACUSE, NY:  
2,865,161, CANC. INT. CL. 42.
- CABOT CORPORATION, BOSTON, MA, GODFREY L. CABOT, INC., BOSTON, MA:  
539,056, REN. 2-26-11, U.S. CL. 11 (INT. CL. 2).
- CACHAVE S.A., (C1425AED) BUENOS AIRES, ARGENTINA:  
2,863,992, CANC. INT. CL. 35.  
2,863,993, CANC. INT. CL. 35.
- CADENA STAR JEWELLERY LTD., CONCORD, ONTARIO, CANADA:  
2,864,033, CANC. INT. CL. 14.
- CADENT LTD, OR YEHUDA, ISRAEL:  
3,939,621, PUB. 1-18-2011, INT. CL. 9.  
3,939,622, PUB. 1-18-2011, INT. CL. 9.
- CADENT MEDICAL COMMUNICATIONS, LLC, IRVING, TX:  
2,864,367, CANC. INT. CL. 41.
- CADIE PRODUCTS CORPORATION, PATERSON, NJ:  
2,000,386, CANC. INT. CL. 1.
- CADILLAC JACK, INC., DULUTH, GA:  
3,942,315, INT. CL. 9.
- CAFE RIO, INC., SALT LAKE CITY, UT:  
2,389,800, REN. 2-26-11, INT. CL. 42.
- CALCADOS MYRABEL LTDA., SAPIRANGA, BRAZIL:  
3,940,200, PUB. 1-18-2011, INT. CL. 25.
- CALGIN, INC., ALBANY, NY:  
2,864,349, CANC. INT. CL. 43.
- CALIBER LEASING, LLC, LAKEWOOD, CO:  
3,939,705, PUB. 1-18-2011, INT. CL. 17.
- CALICUT SOFTWARE, INC., MIDLAND, TX:  
3,940,761, PUB. 1-18-2011, INT. CL. 9.
- CALIFORNIA ACADEMY OF SCIENCES, SAN FRANCISCO, CA:  
3,942,344, INT. CL. 42.
- CALIFORNIA BAPTIST UNIVERSITY, RIVERSIDE, CA:  
3,940,321, PUB. 1-18-2011, INT. CL. 41.
- CALIFORNIA HOME CARE, INC., SAN DIEGO, CA:  
2,368,360, CANC. INT. CL. 42.
- CALIFORNIA SCENTS, IRVINE, CA:  
1,147,929, REN. 2-28-11, MULTIPLE CLASS, INT. CLS. 5 AND 11.
- CALIFORNIA TRUSS COMPANY, PERRIS, CA:  
3,940,427, PUB. 1-18-2011, INT. CL. 19.
- CALIFORNIA WALNUT BOARD, FOLSOM, CA:  
2,479,195, REN. 2-26-11, INT. CL. 35.
- CALIFORNIA ACADEMY OF SCIENCES, SAN FRANCISCO, CA:  
2,367,358, CANC. INT. CL. 41.
- CALLAWAY GOLF COMPANY, CARLSBAD, CA:  
2,430,553, REN. 2-26-11, INT. CL. 28.
- CALLCENTRIC WHOLESALE, INC., NEW YORK, NY, FORMERLY ACCATEL, INC.:  
3,941,133, INT. CL. 35.
- CAME GROUP S.P.A., ITALY:  
3,939,999, PUB. 1-18-2011, MULTIPLE CLASS, INT. CLS. 6, 7, 9, 19, 35, 37, 41, 42 AND 45.
- CAMEO DESIGNS, LTD., NEW YORK, NY:  
1,665,789, REN. 3-2-11, INT. CL. 14.
- CAMERICAN INTERNATIONAL, INC., PARAMUS, NJ:  
2,865,105, CANC. INT. CL. 29.
- CAMP BOW WOW DISTRIBUTION LLC, BOULDER, CO:  
3,903,069, COR. INT. CL. 36.
- CAMP NORTH STAR FOR BOYS, INC., HAYWARD, WI:  
3,939,435, PUB. 11-2-2010, INT. CL. 41.  
3,939,436, PUB. 11-2-2010, INT. CL. 41.
- CAMPBELL SUPPLY CO., IOWA FALLS, IA:  
1,155,334, REN. 3-1-11, INT. CL. 7.
- CAMPUS LIVING VILLAGES; PTY LIMITED, SYDNEY NSW 2000, AUSTRALIA:  
3,939,967, PUB. 1-18-2011, MULTIPLE CLASS, INT. CLS. 25, 35, 36, 37 AND 43.
- CANAL + D.A., BOULOGNE BILLANCOURT, FRANCE:  
2,865,462, CANC. INT. CL. 9.
- CANCEROPINIONS.COM, LLC, OMAHA, NE:  
3,942,146, INT. CL. 44.
- CANDID CAREER, LLC, BETHESDA, MD:  
3,941,155, INT. CL. 35.
- CANEM WORLD, INC., BEAUMONT, CA:  
3,940,295, PUB. 1-18-2011, INT. CL. 45.
- CANNON & ASSOCIATES FINANCIAL AND BUSINESS SOLUTIONS, LLC, FEDERAL WAY, WA, DBA CANNON WEALTH MANAGEMENT:  
3,940,316, PUB. 1-18-2011, INT. CL. 36.
- CANTINA SOCIALE BEATO BARTOLOMEO DA BREGANZE SOCIETA' COOPERATIVA AGRICOLA A RESPONSABILITA' LIMITATA, BREGANZE (VI), ITALY:  
3,940,230, PUB. 12-21-2010, INT. CL. 33.
- CANTINA SOCIALE COOPERATIVA DI SOAVE - SOCIETA' AGRICOLA COOPERATIVA, SOAVE (VR), ITALY:  
3,942,152, INT. CL. 33.
- CAPELLA COLLECTION LLC, ROCKVILLE, MD, DBA CAPELLA COLLECTION:  
3,939,793, PUB. 1-18-2011, INT. CL. 21.
- CAPETOWN-RIO, INC., REDMOND, WA:  
2,367,935, CANC. INT. CL. 41.
- CAPITAL ADVISORS GROUP, INC., NEWTON, MA:  
3,942,144, INT. CL. 36.
- CAPITUS PTE LTD, SINGAPORE, SINGAPORE:  
3,942,145, INT. CL. 9.
- CAPRI OPTICS, BROOKLYN, NY:  
3,942,118, INT. CL. 9.



CAPSCANADA CORPORATION, TECUMSEH, CANADA:  
3,940,935, PUB. 1-18-2011. INT. CL. 5.  
3,940,938, PUB. 1-18-2011. INT. CL. 5.

CAPSUGEL BELGIUM BVBA, BORNEM, BELGIUM:  
3,941,816, INT. CL. 9.

CAPTURE WINE BRANDS LLC, HEALDSBURG, CA:  
3,942,221, INT. CL. 33.

CAR CASH OF NEW YORK, INC., NEW YORK, NY:  
2,444,288, REN. 2-26-11. INT. CL. 35.

CAR DONATION FOUNDATION, ST. PAUL, MN:  
3,940,258, PUB. 1-18-2011. INT. CL. 36.

CARBODEON LTD OY, FINLAND:  
3,939,887, PUB. 1-18-2011. MULTIPLE CLASS, INT. CLS. 1 AND 4.

CARBODIAM SA, BELGIUM:  
3,939,930, PUB. 1-18-2011. INT. CL. 7.

CARDIAC PACEMAKERS, INC., ST. PAUL, MN:  
2,419,953, REN. 3-1-11. INT. CL. 10.

CARDINAL CAPITAL MANAGEMENT, INC., RALEIGH, NC:  
2,436,074, REN. 2-26-11. INT. CL. 36.

CARDINAL HEALTH 107, LLC, DUBLIN, OH:  
2,369,309, CANC. INT. CL. 5.

CARE CONNECTIONS, INC., FOXBORO, MA:  
3,939,849, PUB. 1-18-2011. INT. CL. 45.

CARE GROUP, INC., BOSTON, MA:  
2,177,852, CANC. INT. CL. 42.

CAREER COLLEGE ASSOCIATION, WASHINGTON, DC:  
3,942,437, INT. CL. 35.

CAREERBUILDER, LLC, CHICAGO, IL:  
3,940,560, PUB. 1-18-2011. INT. CL. 35.

CARGILL, INCORPORATED, WAYZATA, MN:  
146,202, REN. 2-25-11. U.S. CL. 6 (INT. CL. 30).  
3,941,347, INT. CL. 29.

CARGO IN ACTION!, CORP., DORAL, FL, DBA FRESHNET:  
3,940,829, PUB. 1-18-2011. INT. CL. 39.

CARIBBEAN PUBLISHING & SERVICES, INC., MIAMI, FL:  
2,775,330, CANC. INT. CL. 16.

CARL ZEISS AG, OBERKOCHEM, FED REP GERMANY:  
3,940,330, PUB. 1-18-2011. INT. CL. 9.

CARLEY, ADAM L., WINDHAM, NH AND SYTEK, JOHN, SALEM, NH:  
2,696,996, CANC. INT. CL. 35.

CARLSON CRAFT, INC., NORTH MANKATO, MN:  
2,536,604, REN. 3-2-11. INT. CL. 42.

CARLSON PARTNERS GROUP, LLC, ST. CROIX FALLS, WI:  
2,864,505, CANC. INT. CL. 37.

CARNAHAN, KEVIN J., ARLINGTON, VA:  
2,865,367, CANC. MULTIPLE CLASS, INT. CLS. 16 AND 41.

CARNIVAL CORPORATION, MIAMI, FL:  
2,369,071, CANC. INT. CL. 41.  
2,381,810, REN. 2-26-11. INT. CL. 18.  
2,381,810, CANC. INT. CL. 21.

CAROLINA ONE, INC., GREENSBORO, NC:  
3,939,427, PUB. 1-18-2011. INT. CL. 33.

CARPENTER, DALE F., TRAVERSE CITY, MI:  
2,864,742, CANC. INT. CL. 41.

CARR, CLINTON, BROOKLYN, NY:  
3,941,334, INT. CL. 25.

CARRIAGE SERVICES, INC, HOUSTON, TX:  
2,513,810, REN. 3-2-11. INT. CL. 42.  
2,513,810, CANC. INT. CL. 36.

CARRINI, INC., EDISON, NJ:  
2,864,351, CANC. INT. CL. 25.

CARROLL, CRYSTAL, PASCO, WA:  
3,942,000, INT. CL. 43.

CARRS PAPER LIMITED, SOLIHULL, WEST MIDLANDS, UNITED KINGDOM:  
2,864,733, CANC. MULTIPLE CLASS, INT. CLS. 16 AND 40.

CARTER HOLT HARVEY LIMITED, MANUKAU CITY, AUCKLAND, NEW ZEALAND:  
2,367,499, CANC. INT. CL. 16.

CARTIER INTERNATIONAL A.G., 6312 STEINHAUSEN, SWITZERLAND, CARTIER, INCORPORATED, NEW YORK, NY:  
897,507, REN. 3-3-11. MULTIPLE CLASS, U.S. CLS. 100 (INT. CL. 42) AND 103 (INT. CL. 37).

CARVIN POOL EQUIPMENT INC., ST. HYACINTHE, QUEBEC, CANADA:  
2,321,774, REN. 3-2-11. INT. CL. 11.

CASA MEXICANA, LLC, DALLAS, TX:  
2,865,784, CANC. MULTIPLE CLASS, INT. CLS. 37 AND 42.

CASA TEQUILERA DE ARANDAS, S.A. DE C.V., ARANDAS, JALISCO, MEXICO:  
3,940,539, PUB. 1-18-2011. INT. CL. 33.

CASAL THAUERO SRL, ITALY:  
3,939,917, PUB. 1-18-2011. INT. CL. 33.

CASCADE CENTERS, INCORPORATED, PORTLAND, OR, DBA CASCADE EAP:  
3,939,768, PUB. 1-18-2011. INT. CL. 35.

CASEMARK, INC., WILMINGTON, DE:  
3,942,242, INT. CL. 8.

CASEY PRODUCTS, INC., LISLE, IL:  
2,369,224, CANC. INT. CL. 6.

CASSEL, DONALD D., PACIFIC PALISADES, CA:  
2,865,597, CANC. INT. CL. 28.

CASSIDY & PINKARD INC., WASHINGTON, DC:  
2,864,609, CANC. INT. CL. 36.

CATIMINI, FRANCE:  
3,940,025, PUB. 1-18-2011. INT. CL. 25.

CAVE DE LABASTIDE DE LEVIS, FRANCE:  
3,940,006, PUB. 1-18-2011. INT. CL. 33.

CAVENDER INVESTMENT PROPERTIES, LTD., TYLER, TX:  
3,940,439, PUB. 1-18-2011. INT. CL. 35.

CAWLEY, GARY, ROSWELL, GA:  
2,865,022, CANC. INT. CL. 9.

CCINTEGRATION INC., SAN JOSE, CA:  
3,940,132, PUB. 1-18-2011. INT. CL. 35.

CCTV CAMERA PROS, BOYNTON BEACH, FL:  
3,940,215, PUB. 1-18-2011. INT. CL. 35.

CDC APPAREL, INC., LOS ANGELES, CA:  
3,941,953, INT. CL. 25.

CELCOLE, INC., HOUSTON, TX:  
2,865,537, CANC. INT. CL. 1.  
2,865,538, CANC. INT. CL. 1.

CELESTIAL SEASONINGS, INC., BOULDER, CO:  
3,941,065, INT. CL. 32.

CELGENE CORPORATION, SUMMIT, NJ:  
3,940,196, PUB. 1-18-2011. INT. CL. 42.

CELL CITY CO., MIRAMAR, FL:  
3,940,775, PUB. 1-18-2011. INT. CL. 9.

CELLCO PARTNERSHIP, BASKING RIDGE, NJ, DBA VERIZON WIRELESS:  
3,941,473, INT. CL. 35.

CELLECTIS, FRANCE:  
3,939,980, PUB. 1-18-2011. MULTIPLE CLASS, INT. CLS. 1, 5, 9, 42 AND 45.

CELULOSA CAMPANA S.A., BUENOS AIRES, ARGENTINA:  
2,864,825, CANC. INT. CL. 16.

CENCES INC., LOS ANGELES, CA:  
2,448,699, REN. 2-25-11. INT. CL. 7.  
2,473,658, REN. 2-25-11. INT. CL. 7.

CENTER FOR INTERNATIONAL PRIVATE ENTERPRISE, WASHINGTON, DC:  
2,503,658, REN. 2-28-11. INT. CL. 42.

CENTER FOR TRADITIONAL CHINESE MEDICINE, INC., THE, SARASOTA, FL:  
2,864,425, CANC. INT. CL. 5.

CENTERLINE MEDIA, LLC, AMBLER, PA:  
3,940,456, PUB. 1-18-2011. INT. CL. 41.

CENTRAL BEAN CO., INC., QUINCY, WA:  
2,894,018, CANC. INT. CL. 25.

CENTRAL COATING COMPANY, INC., MADERA, CA:  
2,864,248, CANC. INT. CL. 17.

CENTRIS CONSULTING, INC., SCRANTON, PA:  
3,941,482, INT. CL. 35.  
3,941,484, INT. CL. 35.

- CENTRIX SOLUTIONS, INC., LINCOLN, NE:  
2,659,625, CANC. INT. CL. 42.
- CENTRO INTERNACIONAL DE EDUCACION Y DESARROLLO (CIED), LOS TEQUES, EST. MIRANDA, VENEZUELA:  
2,864,131, CANC. MULTIPLE CLASS, INT. CLS. 9 AND 16.
- CERACASA, S.A., 12110 L'ALCORA (CASTELLON), SPAIN:  
2,864,246, CANC. INT. CL. 19.
- CERAMICA ALBERDI SA, SANTA FE, ARGENTINA:  
3,941,208, INT. CL. 19.
- CERATECH, INC., RICHMOND, VA:  
2,865,214, CANC. INT. CL. 1.
- CEREALUS HOLDINGS LLC, WATERVILLE, ME:  
3,939,671, PUB. 1-18-2011. INT. CL. 1.  
3,940,085, PUB. 1-18-2011. INT. CL. 1.
- CERTAINTED CEILINGS CORPORATION, VALLEY FORGE, PA:  
2,402,380, REN. 3-2-11. INT. CL. 17.  
2,404,519, REN. 3-2-11. INT. CL. 17.
- CERVECERIA MODELO, S.A. DE C.V., 11320 MEXICO, D.F., MEXICO:  
2,864,711, CANC. INT. CL. 32.
- CESARE FIORUCCI S.P.A., ITALY:  
3,940,051, PUB. 1-18-2011. INT. CL. 29.
- CESSNA FINANCE CORPORATION, WICHITA, KS:  
2,437,899, REN. 2-26-11. INT. CL. 36.
- CEWE COLOR AG & CO. OHG, FED REP GERMANY:  
3,940,035, PUB. 1-18-2011. MULTIPLE CLASS, INT. CLS. 16 AND 40.
- CHAINFORMATION MANAGEMENT SYSTEMS AB, SE-21140 MALMO, SWEDEN:  
2,864,039, CANC. MULTIPLE CLASS, INT. CLS. 9, 35 AND 42.
- CHAIRWORKS HOLDINGS INVESTMENT LIMITED, ROAD TOWN, TORTOLA, BR. VIRGIN ISLANDS:  
3,939,613, PUB. 1-18-2011. INT. CL. 20.
- CHALLENGE & FUN INC., ASHLAND, MA:  
2,723,832, CANC. INT. CL. 35.
- CHAMBERS, STEPHEN E., FREDERICK, MD AND VAN DER VEER, LYNN C., FREDERICK, MD:  
2,754,777, CANC. MULTIPLE CLASS, INT. CLS. 38 AND 42.
- CHAMPAGNE LANSON, 51100 REIMS, FRANCE, LANSON PERE & FILS, SOCIETE ANONYME, REIMS (MARNE), FRANCE:  
908,188, REN. 2-26-11. U.S. CL. 47 (INT. CL. 33).
- CHAMPION WIRELESS, CORP., BROOKLYN, NY:  
2,864,932, CANC. INT. CL. 35.
- CHAMPIONSHIP COMMUNICATIONS, FRIENDSWOOD, TX:  
3,940,356, PUB. 1-18-2011. INT. CL. 38.
- CHANNEL MECHANICS LIMITED, HASLEMERE, SURREY, UNITED KINGDOM:  
3,939,504, PUB. 1-18-2011. MULTIPLE CLASS, INT. CLS. 35 AND 42.  
3,939,505, PUB. 1-18-2011. MULTIPLE CLASS, INT. CLS. 35 AND 42.
- CHARMANTE S.R.L., ITALY:  
3,885,598, COR. MULTIPLE CLASS, INT. CLS. 9 AND 25.
- CHARTERING YOUR OWN COURSE FOUNDATION, GAITHERSBURG, MD:  
2,865,233, CANC. INT. CL. 41.
- CHARTPAK, INC., MELVILLE, NY:  
3,941,093, INT. CL. 2.
- CHATEAU MORRISSETTE, INC., FLOYD, VA:  
3,940,457, PUB. 1-18-2011. INT. CL. 25.  
3,940,459, PUB. 1-18-2011. MULTIPLE CLASS, INT. CLS. 21 AND 33.
- CHE-WEN LIN, TAIPEI COUNTY, TAIWAN:  
3,941,643, INT. CL. 18.  
3,941,644, INT. CL. 25.
- CHECKERS DRIVE-IN RESTAURANTS, INC., CLEARWATER, FL:  
2,513,306, REN. 3-1-11. INT. CL. 30.
- CHECKERS DRIVE-IN RESTAURANTS, INC., TAMPA, FL:  
3,941,514, INT. CL. 43.  
3,941,868, INT. CL. 30.
- CHECKFREE SERVICES CORPORATION, NORCROSS, GA:  
2,865,440, CANC. INT. CL. 9.
- CHEF LOCKER, LLC, SAINT PETERS, MO:  
3,941,452, INT. CL. 8.
- CHEFSMART, INC., GARDENA, CA:  
3,940,795, PUB. 1-18-2011. INT. CL. 21.
- CHEFWEAR, INC., ADDISON, IL:  
3,942,068, INT. CL. 35.
- CHEIL INDUSTRIES INC., KYUNGSANGBUK-DO, REPUBLIC OF KOREA:  
3,939,449, PUB. 1-18-2011. MULTIPLE CLASS, INT. CLS. 18, 25 AND 35.
- CHEMADVISOR, INC., PITTSBURGH, PA:  
2,537,539, REN. 2-26-11. INT. CL. 9.
- CHEMGLASS INC., VINELAND, NJ:  
2,535,694, REN. 3-3-11. INT. CL. 9.
- CHENG, JAMES TEE, PICO RIVERA, CA, DBA JC TRADING:  
3,941,566, INT. CL. 30.
- CHEVYS RESTAURANTS, LLC, CYPRESS, CA:  
3,941,569, INT. CL. 29.
- CHF INDUSTRIES INC., NEW YORK, NY:  
3,940,939, PUB. 1-18-2011. MULTIPLE CLASS, INT. CLS. 20, 21, 24 AND 27.
- CHICAGO JEWISH NEWS FRONT PAGE COUNCIL IN MEMORY OF CHAIM ZVI, SKOKIE, IL:  
2,503,619, REN. 3-2-11. MULTIPLE CLASS, INT. CLS. 16, 41 AND 42.
- CHICAGO PROVINCE OF THE SOCIETY OF JESUS, CHICAGO, IL:  
3,940,143, PUB. 1-18-2011. INT. CL. 16.
- CHICKERING, DONN A. JR., GOLETA, CA:  
2,864,678, CANC. INT. CL. 41.
- CHILDPROOFERS, INC., DEERFIELD, IL:  
2,369,030, CANC. MULTIPLE CLASS, INT. CLS. 35 AND 42.
- CHILDREN OF PROMISE INTERNATIONAL, CENTERVILLE, OH:  
2,865,604, CANC. MULTIPLE CLASS, INT. CLS. 36 AND 42.
- CHILEI, LLC, ELLSWORTH, WI:  
3,941,552, INT. CL. 42.
- CHINA CONNECTION, INC., PHOENIX, MD:  
3,940,141, PUB. 10-12-2010. INT. CL. 44.
- CHINA JILIN FOREST INDUSTRY GROUP CO., LTD., CHINA:  
3,879,392, COR. INT. CL. 32.
- CHINA STAR TRADEMARK LIMITED, TORTOLA, BR. VIRGIN ISLANDS:  
2,863,956, CANC. MULTIPLE CLASS, INT. CLS. 9, 16, 38, 41 AND 42.
- CHINESE CARPETS & RUGS, INC., ONTARIO, CA:  
2,865,797, CANC. INT. CL. 16.
- CHOICE HOTELS INTERNATIONAL, INC., SILVER SPRING, MD:  
3,942,288, INT. CL. 43.
- CHOMARAT COMPOSITES, 75002 PARIS, FRANCE:  
2,865,029, CANC. INT. CL. 24.
- CHOOSE HOPE INC., SUN PRAIRIE, WI:  
3,940,435, PUB. 1-18-2011. INT. CL. 25.  
3,940,437, PUB. 1-18-2011. INT. CL. 14.
- CHOW, KELLEN, BROOKLYN, NY:  
3,940,698, PUB. 1-18-2011. MULTIPLE CLASS, INT. CLS. 30, 35 AND 43.
- CHR. HANSEN A/S, HORSHOLM, DENMARK:  
3,939,600, PUB. 1-18-2011. INT. CL. 1.
- CHRISTAL, DEAN V., SANTA BARBARA, CA:  
3,942,231, INT. CL. 3.
- CHRISTENSON, DALE CARL, ATLANTIC BEACH, FL:  
2,865,164, CANC. INT. CL. 43.
- CHRISTIAN BROTHERS SERVICES, ROMEOVILLE, IL:  
2,368,415, CANC. INT. CL. 16.
- CHRISTIANO JOSEPH A, DELAND, FL:  
3,940,784, PUB. 1-18-2011. INT. CL. 5.
- CHRYSLER GROUP LLC, AUBURN HILLS, MI:  
3,941,344, INT. CL. 12.

CHS INC., INVER GROVE HEIGHTS, MN:  
2,515,190. REN. 3-2-11. INT. CL. 4.  
2,541,350. REN. 3-1-11. INT. CL. 35.

CHU, DARRYL, FOREST HILLS, NY:  
3,942,112, INT. CL. 9.

CHUBB INTERNATIONAL HOLDINGS LIMITED, DERBY,  
UNITED KINGDOM:  
2,864,066, CANC. MULTIPLE CLASS, INT. CLS. 9, 16  
AND 45.

CHUN, AARON, HERCULES, CA:  
2,456,574. REN. 2-26-11. INT. CL. 3.

CHURCH & DWIGHT CO., INC., PRINCETON, NJ:  
2,865,787, CANC. INT. CL. 5.  
3,941,983, INT. CL. 21.  
3,942,263, INT. CL. 3.

CHURCHILL DOWNS INCORPORATED, LOUISVILLE, KY:  
3,941,581, INT. CL. 41.

CIANCI, DEBRA L, PALM HARBOR, FL, DBA HAIR  
DETAILERS:  
3,942,100, INT. CL. 3.

CIESPACE CORPORATION, PITTSBURGH, PA:  
3,939,424, PUB. 1-18-2011. INT. CL. 9.

CIGARS INTERNATIONAL, INC., BETHLEHEM, PA:  
3,535,112, CANC. INT. CL. 34.

CINDY-ANN CREATIONS INC., MONTREAL, QUEBEC,  
CANADA:  
2,369,086, CANC. INT. CL. 25.

CINNAMONSTER FRANCHISE GROUP, INC., ENGLE-  
WOOD, CO:  
2,509,394. REN. 2-28-11. INT. CL. 30.

CIRILLO, MAUREEN ELIZABETH, WINTHROP, MA, DBA  
EVELYN JANICE DESIGNS:  
3,941,954, INT. CL. 26.

CIRQUE POLYNESIA MAUI, LLC, HONOLULU, HI:  
3,940,914, PUB. 1-18-2011. MULTIPLE CLASS, INT. CLS.  
25 AND 41.

CISCO TECHNOLOGY, INC., SAN JOSE, CA:  
3,940,188, PUB. 1-18-2011. INT. CL. 9.

CITI-ADVERTISING, INC., GLENDALE, CA:  
3,281,409, CANC. INT. CL. 35.

CITIZENS FINANCIAL GROUP, INC., BOSTON, MA, DBA  
CITIZENS BANK:  
3,940,194, PUB. 1-18-2011. INT. CL. 35.

CITRIX ONLINE LLC, GOLETA, CA:  
3,940,455, PUB. 1-18-2011. INT. CL. 42.  
3,940,686, PUB. 1-18-2011. INT. CL. 42.

CITY OF BROOKINGS, SOUTH DAKOTA, BROOKINGS,  
SD:  
3,940,218, PUB. 1-18-2011. INT. CL. 35.

CITY OF MIAMISBURG, MIAMISBURG, OH:  
2,522,124. REN. 2-26-11. INT. CL. 42.

CITY OF MISSOULA, MISSOULA, MT, DBA CURRENTS:  
3,940,328, PUB. 1-18-2011. INT. CL. 41.

CITY OF RAMSEY, RAMSEY, MN:  
3,940,363, PUB. 1-18-2011. INT. CL. 37.

CJ CHEILJEDANG CORPORATION, SEOUL, REPUBLIC OF  
KOREA:  
3,939,437, PUB. 1-18-2011. INT. CL. 30.

CJM PRODUCTS, INC., FRANKLIN, NJ:  
2,367,652, CANC. INT. CL. 8.

CLABBER GIRL CORPORATION, TERRE HAUTE, IN:  
3,941,194, INT. CL. 1.

CLAD HOLDINGS CORP., CANONSBURG, PA:  
2,422,746. REN. 3-2-11. MULTIPLE CLASS, INT. CLS. 8, 9,  
20 AND 21.

CLARENDON CAPITAL CORPORATION, ATLANTA, GA:  
3,941,869, INT. CL. 35.

CLARIANT AG, MUTTENZ, SWITZERLAND:  
2,865,617, CANC. INT. CL. 1.

CLARK, BARBARA, RUMSON, NJ:  
3,940,655, PUB. 1-18-2011. INT. CL. 41.

CLARK, BARBARA A., RUMSON, NJ:  
3,940,880, PUB. 1-18-2011. INT. CL. 41.

CLARK, GLORIA D., LOS ANGELES, CA:  
2,864,588, CANC. INT. CL. 16.

CLARK, HARVEY P., BOYLSTON, MA:  
2,865,839, CANC. INT. CL. 30.

CLARK, MICHAEL W., BREA, CA:  
2,865,307, CANC. INT. CL. 30.

CLARY INVESTMENTS INC, MILFORD, IA:  
2,431,156. REN. 2-26-11. INT. CL. 7.

CLAUSEN MILLER, P.C., CHICAGO, IL:  
2,465,508. REN. 2-26-11. INT. CL. 42.

CLEANCANDY SWEDEN AKTIEBOLAG, ARVIKA, SWE-  
DEN:  
3,940,283, PUB. 1-18-2011. MULTIPLE CLASS, INT. CLS.  
9, 21 AND 30.

CLEAR CHANNEL BROADCASTING, INC., SAN ANTO-  
NIO, TX:  
2,865,010, CANC. INT. CL. 38.

CLEAR CHANNEL OUTDOOR, INC., SAN ANTONIO, TX:  
3,942,142, INT. CL. 9.

CLEAR CUSTOM LLC, STERLING HEIGHTS, MI:  
3,940,580, PUB. 1-18-2011. INT. CL. 16.

CLEAR-CUT COMPUTING CORP., FARMINGDALE, NY:  
2,865,145, CANC. INT. CL. 9.

CLEVELAND LIVE INC., CLEVELAND, OH:  
2,863,888, CANC. INT. CL. 41.

CLEVELAND, WILLIAM, JR., DUBLIN, CA, DBA ALAME-  
DA RESEARCH GROUP:  
2,865,329, CANC. INT. CL. 42.

CLICK IT, LLC, WOODSTOCK, GA:  
2,864,494, CANC. INT. CL. 35.

CLIMACHECK SWEDEN AB, SWEDEN:  
3,940,077, PUB. 1-18-2011. MULTIPLE CLASS, INT. CLS. 9  
AND 38.

CLINE, CAMILLE N., DALLAS, TX:  
2,864,857, CANC. INT. CL. 41.

CLINTON REALTY COMPANIES, INC., GRANDVILLE, MI:  
2,864,688, CANC. INT. CL. 37.

CLOCKWORK IP, LLC, SARASOTA, FL:  
2,865,441, CANC. INT. CL. 37.  
3,941,269, INT. CL. 37.

CLOTHESTIME STORES, INC., DALLAS, TX:  
2,863,907, CANC. INT. CL. 35.

CLOUD RIDERS LTD., PAPHOS, CYPRUS:  
3,942,194, MULTIPLE CLASS, INT. CLS. 9 AND 41.

CLOUD SAFE BACKUP, LLC, CAMARILLO, CA:  
3,942,451, INT. CL. 9.

CLUBSCENECRITICS.COM LLC, LAS VEGAS, NV:  
3,940,739, PUB. 1-18-2011. INT. CL. 35.

CMA CGM, MARSEILLE, FRANCE:  
2,864,810, CANC. INT. CL. 39.

CMH SERVICES, INC., MARYVILLE, TN:  
2,367,527, CANC. INT. CL. 35.

CNA FINANCIAL CORPORATION, CHICAGO, IL:  
3,941,304, INT. CL. 36.

CNL INCOME MOUNTAIN HIGH TRS CORP., WILMING-  
TON, DE:  
3,941,380, INT. CL. 41.

CO, EMILY, SAN FRANCISCO, CA:  
3,940,840, PUB. 1-18-2011. INT. CL. 41.

COALISION INC., LONGUEUIL, QUEBEC:  
2,864,117, CANC. MULTIPLE CLASS, INT. CLS. 18 AND  
25.

COALITION OF BONE HEALTH EDUCATORS, LLC, MON-  
ROE TOWNSHIP, NJ:  
3,942,432, INT. CL. 16.  
3,942,433, INT. CL. 9.

COAST TO COAST HEALTHCARE SERVICES INCORPO-  
RATED, NEW ALBANY, OH:  
3,939,553, PUB. 1-18-2011. INT. CL. 35.

COBOS, LUCY, CAMBRIDGE, MA, DBA PEE HAPPY:  
3,940,758, PUB. 1-18-2011. INT. CL. 25.

COCKY JOCKS, LLC, DENT, MN:  
3,941,153, INT. CL. 25.  
3,941,154, INT. CL. 25.

CODAN HOLDING GMBH, 23738 LENSahn, FED REP  
GERMANY:  
1,638,977. REN. 2-28-11. INT. CL. 10.

CODE MANAGEMENT, LLC, NEW YORK, NY:  
2,864,535, CANC. INT. CL. 35.

CODE SYSTEMS, INC., TROY, MI:  
2,369,274, CANC. INT. CL. 12.

- COGNITIVE SCIENCE LLC, ITHACA, NY:  
3,941,268, INT. CL. 21.
- COHEN ASSET MANAGEMENT, INC., BEVERLY HILLS, CA:  
3,940,217, PUB. 1-18-2011, INT. CL. 36.
- COLD STAR SALES & LEASING, INC., MOUNT EPHRAIM, NJ, AKA COLD STAR:  
3,941,957, INT. CL. 29.
- COLE HAAN, YARMOUTH, ME:  
1,636,109, REN. 3-2-11, INT. CL. 18.  
1,636,109, CANC. INT. CL. 14.
- COLE'S QUALITY FOODS, INC., GRAND RAPIDS, MI,  
COLE BAKERIES, INC., MUSKEGON, MI:  
1,153,324, REN. 2-26-11, INT. CL. 30.
- COLGATE-PALMOLIVE COMPANY, NEW YORK, NY:  
2,408,460, REN. 2-26-11, INT. CL. 3.
- COLLE DI BOASI S.A., MENDOZA, ARGENTINA:  
3,941,361, INT. CL. 33.
- COLLEGE OF WILLIAM AND MARY IN VIRGINIA, THE,  
WILLIAMSBURG, VA:  
1,676,169, REN. 2-27-11, INT. CL. 41.
- COLOMER, S.A. DE C.V., EDO. DE MEXICO, MEXICO:  
3,939,609, PUB. 1-18-2011, INT. CL. 23.
- COLORADO SEMINARY, DENVER, CO:  
2,865,400, CANC. INT. CL. 41.
- COLORE ACCESORIOS S. DE R. L DE C.V., GUADALAJARA, MEXICO:  
3,941,252, INT. CL. 14.
- COLUMBIA INSURANCE COMPANY, OMAHA, NE:  
1,657,089, REN. 3-2-11, INT. CL. 2.
- COLUMBUS INDUSTRIES, INC., ASHVILLE, OH:  
3,942,266, INT. CL. 11.
- COMEDY PARTNERS, NEW YORK, NY:  
2,864,799, CANC. INT. CL. 41.
- COMMERCIAL BAKERIES CORP., TORONTO, ONTARIO,  
CANADA:  
2,499,178, REN. 3-2-11, INT. CL. 30.
- COMMERCIAL CARPETS OF AMERICA, ALEXANDRIA,  
VA:  
2,864,615, CANC. INT. CL. 37.
- COMMONWEALTH GENERAL CORPORATION, LOUISVILLE, KY:  
3,941,684, INT. CL. 36.
- COMMUNICATION INTELLIGENCE CORPORATION,  
REDWOOD SHORES, CA:  
2,865,270, CANC. INT. CL. 9.
- COMMUNITEACH LLC, CHICAGO, IL:  
3,940,756, PUB. 1-18-2011, INT. CL. 42.
- COMMUNITY & SOUTHERN BANK, CARROLLTON, GA:  
3,941,874, INT. CL. 36.  
3,941,880, INT. CL. 36.
- COMMUNITY AGENCY NETWORK LLC, SOUTH WINDSOR, CT, DBA COMMUNITY INSURANCE CENTERS:  
3,942,244, INT. CL. 35.
- COMMUNITY STATE BANCSHARES, INC., WICHITA, KS:  
2,502,593, REN. 2-25-11, INT. CL. 36.
- COMMUNITY TAX RELIEF, LLC, CHICAGO, IL:  
3,942,440, MULTIPLE CLASS, INT. CLS. 36 AND 45.
- COMMUNITY UNITED AGAINST VIOLENCE, SAN FRANCISCO, CA:  
2,367,606, CANC. INT. CL. 42.
- COMMUNITYAMERICA CREDIT UNION, LENEXA, KS:  
3,942,408, INT. CL. 35.
- COMPAGNIE FINANCIERE ET DE PARTICIPATIONS ROULLIER, F-35400 SAINT-MALO, FRANCE:  
3,940,016, PUB. 1-18-2011, MULTIPLE CLASS, INT. CLS. 1 AND 5.
- COMPANY ONE, INC., LAS VEGAS, NV:  
2,460,385, REN. 3-3-11, INT. CL. 37.
- COMPASS BANCSHARES, INC., BIRMINGHAM, AL:  
3,940,535, PUB. 1-18-2011, INT. CL. 36.  
3,940,941, PUB. 1-18-2011, INT. CL. 41.  
3,940,943, PUB. 1-18-2011, INT. CL. 41.
- COMPLEMENTARY TECHNOLOGIES LIMITED, LANCASHIRE BL5 3QJ, UNITED KINGDOM:  
2,653,567, CANC. MULTIPLE CLASS, INT. CLS. 9 AND 42.
- COMPLIANCE 360, INC., ALPHARETTA, GA:  
3,939,852, PUB. 1-18-2011, INT. CL. 42.
- COMPOZ-A-PUZZLE, INC., PORT WASHINGTON, NY:  
2,367,638, CANC. INT. CL. 42.
- COMPUPAY, INC., MIRAMAR, FL:  
1,643,163, REN. 3-3-11, INT. CL. 35.  
2,444,848, REN. 2-26-11, INT. CL. 35.
- COMPUTER ASSOCIATES THINK, INC., ISLANDIA, NY:  
2,865,250, CANC. INT. CL. 9.
- COMPUTER CHROME, INC., MINNEAPOLIS, MN, DBA SIGHT MARKETING:  
3,941,619, MULTIPLE CLASS, INT. CLS. 35 AND 42.
- COMPUTER MENTORS GROUP, INC., TAMPA, FL:  
3,939,450, PUB. 1-18-2011, MULTIPLE CLASS, INT. CLS. 41 AND 42.
- COMPUTERIZED SECURITY SYSTEMS, INC., COSTA MESA, CA:  
2,864,902, CANC. INT. CL. 9.
- COMSCORE, INC., RESTON, VA:  
2,369,291, CANC. INT. CL. 9.
- CON-WAL, INC., ROGERS, AR, DBA SOUTHWESTERN SALES COMPANY:  
2,865,178, CANC. INT. CL. 17.
- CONAIR CORPORATION, STAMFORD, CT:  
2,367,852, CANC. INT. CL. 26.  
3,940,949, PUB. 1-18-2011, MULTIPLE CLASS, INT. CLS. 9, 11 AND 21.
- CONANT CONTROLS, INC., MEDFORD, MA:  
2,367,698, CANC. INT. CL. 6.
- CONCEPTUAL CALCULATIONS LLC, PETALUMA, CA:  
3,941,823, INT. CL. 9.  
3,941,824, INT. CL. 42.
- CONCORD ANTIQUARIAN SOCIETY, INC., THE, CONCORD, MA:  
2,492,063, REN. 3-3-11, MULTIPLE CLASS, INT. CLS. 35 AND 41.
- CONCORD BRANDS ULC, EDMONTON, ALBERTA, CANADA:  
2,505,036, REN. 2-28-11, INT. CL. 30.
- CONCURRENT COMPUTER CORPORATION, DULUTH, GA:  
2,369,318, CANC. INT. CL. 9.
- CONDITIONED AIR CORPORATION OF NAPLES, INC., NAPLES, FL:  
3,939,564, PUB. 1-18-2011, MULTIPLE CLASS, INT. CLS. 11 AND 37.  
3,939,577, PUB. 1-18-2011, INT. CL. 37.
- CONDOMINIUM CONNECTION, WESTLAKES VILLAGE, CA:  
1,159,098, REN. 2-27-11, MULTIPLE CLASS, INT. CLS. 16 AND 36.
- CONFEDERATE MOTOR COMPANY, MANDEVILLE, LA:  
3,940,494, PUB. 1-18-2011, INT. CL. 12.
- CONFRÉRIE DE LA CHAÎNE DES RÔTISSEURS, F-75009 PARIS, FRANCE:  
3,291,144, CANC. MULTIPLE CLASS, INT. CLS. 16, 41 AND 43.  
3,291,145, CANC. MULTIPLE CLASS, INT. CLS. 16, 41 AND 43.  
3,291,146, CANC. MULTIPLE CLASS, INT. CLS. 16, 41 AND 43.  
3,291,147, CANC. MULTIPLE CLASS, INT. CLS. 16, 41 AND 43.  
3,291,148, CANC. MULTIPLE CLASS, INT. CLS. 16, 41 AND 43.  
3,294,218, CANC. MULTIPLE CLASS, INT. CLS. 16, 41 AND 43.
- CONFRÉRIE DE LA CHAÎNE DES RÔTISSEURS, FRANCE:  
3,298,236, CANC. MULTIPLE CLASS, INT. CLS. 16, 41 AND 43.
- CONFRÉRIE DE LA CHAÎNE DES RÔTISSEURS, F-75009 PARIS, FRANCE:  
3,409,321, CANC. MULTIPLE CLASS, INT. CLS. 16, 41 AND 43.
- CONFRÉRIE DE LA CHAÎNE DES RÔTISSEURS, FRANCE:  
3,462,430, CANC. MULTIPLE CLASS, INT. CLS. 16, 41 AND 43.

CONIL-REICHARD, FERNANDO, MIAMI, FL:  
2,865,180, CANC. INT. CL. 35.

CONIX SYSTEMS, INC., MANCHESTER CENTER, VT:  
2,368,505, CANC. INT. CL. 9.

CONNECTIVA SYSTEMS, INC., NEW YORK, NY:  
3,941,338, MULTIPLE CLASS, INT. CLS. 9, 35 AND 42.

CONNELL, OVID, BROOKLYN, NY, AKA FATHER ONE-  
KO:  
3,940,348, PUB. 1-18-2011. INT. CL. 41.

CONNOR SPORT COURT INTERNATIONAL, INC., SALT  
LAKE CITY, UT:  
2,479,328, REN. 3-3-11. INT. CL. 19.

CONSORZIO CHIANTI COLLI FIORENTINI, ITALY:  
3,939,918, PUB. 1-18-2011. INT. CL. 33.

CONSORZIO CON ATTIVITA' ESTERNA: FRA IMPRENDI-  
TORI COLTELLINAI E FORBICIAI E FABBRICANTI; DI  
UTENSILERIA E SIMILI PER; LO SVILUPPO ECONOM-  
ICO DI PREMANA; E DELLA VALSASSINA (IN SHORT;  
CONSORZIO PREMAX), ITALY:  
3,939,950, PUB. 1-18-2011. INT. CL. 8.

CONSTANTIN DARZENTA, SANDWICH, MA:  
3,942,205, INT. CL. 25.

CONSTRUCTION RESEARCH & TECHNOLOGY GMBH,  
TROSTBERG, FED REP GERMANY:  
3,939,566, PUB. 1-18-2011. INT. CL. 42.

CONSUMER ELECTRONICS CORP., ELM GROVE, WI:  
2,444,664, REN. 3-3-11. INT. CL. 15.

CONTINENTAL PASTRY INC., MASPETH, NY:  
2,368,344, CANC. INT. CL. 30.

CONVERSE INC., NORTH ANDOVER, MA:  
2,453,856, REN. 3-2-11. INT. CL. 42.

CONVERTEAM GROUP, FRANCE:  
3,939,900, PUB. 1-18-2011. MULTIPLE CLASS, INT. CLS.  
7, 9 AND 40.

CONXIS, INC., SAN DIMAS, CA:  
3,941,649, INT. CL. 43.  
3,941,651, INT. CL. 43.  
3,941,652, INT. CL. 43.  
3,941,653, INT. CL. 43.

COOK INCORPORATED, BLOOMINGTON, IN:  
2,369,387, CANC. INT. CL. 10.

COOK MEDICAL TECHNOLOGIES LLC, BLOOMINGTON,  
IN:  
2,432,273, REN. 3-2-11. INT. CL. 10.  
2,432,274, REN. 3-2-11. INT. CL. 10.

COOKER RESTAURANT CORPORATION, NASHVILLE,  
TN:  
2,864,598, CANC. INT. CL. 43.

COOL CYCLES ICE CREAM CO. LLC, TACOMA, WA:  
3,941,013, MULTIPLE CLASS, INT. CLS. 16, 25, 35, 36  
AND 39.

COOL ENERGY, INC., BOULDER, CO:  
3,941,172, INT. CL. 9.

COOL-RAY OPTICS, INC., WOODSIDE, NY:  
908,555, REN. 3-3-11. U.S. CL. 26 (INT. CL. 9).

COOLIRIS, INC., PALO ALTO, CA:  
3,940,791, PUB. 1-18-2011. INT. CL. 38.

COOPER TECHNOLOGIES COMPANY, HOUSTON, TX, B-  
LINE SYSTEMS, INC., HIGHLAND, IL:  
1,656,592, REN. 3-2-11. INT. CL. 6.

COOPERATIVE OF AMERICAN PHYSICIANS, INC., LOS  
ANGELES, CA:  
2,865,809, CANC. INT. CL. 36.

COPART, INC., FAIRFIELD, CA:  
3,941,221, INT. CL. 35.

COPERNIC INC., QUEBEC CITY, QUEBEC, CANADA:  
2,863,977, CANC. MULTIPLE CLASS, INT. CLS. 9 AND  
42.

COR-A-VENT, INC., MISHAWAKA, IN:  
3,939,701, PUB. 1-18-2011. INT. CL. 19.

CORBIN RUSSWIN, INC., BERLIN, CT:  
2,496,994, REN. 2-26-11. INT. CL. 6.

CORCELL, INC., PHILADELPHIA, PA:  
2,865,144, CANC. INT. CL. 44.

CORE BOTANICA, L.L.C., LOUISVILLE, CO:  
3,940,595, PUB. 1-18-2011. INT. CL. 30.

CORE3 SOLUTIONS LLC, BIRMINGHAM, MI:  
3,941,664, MULTIPLE CLASS, INT. CLS. 37 AND 42.

CORNELIA STREET GROUP, INC., NEW YORK, NY:  
2,864,447, CANC. MULTIPLE CLASS, INT. CLS. 29 AND  
43.

CORNERSTONE MANAGEMENT SOLUTIONS, INC., RUM-  
SON, NJ:  
2,368,871, CANC. INT. CL. 9.

CORNERSTONE SEARCH GROUP, LLC, PARSIPPANY, NJ:  
2,465,741, REN. 3-2-11. INT. CL. 35.

CORPORATE BROKERS, LLC, ANNAPOLIS, MD:  
3,942,265, INT. CL. 35.

CORPORATE INK, NEWTON, MA:  
3,941,502, INT. CL. 35.

CORPORATE SCENES, INC., BERKELEY, CA:  
1,915,553, CANC. INT. CL. 41.

CORRECTIONAL HEALTH PARTNERS, DENVER, CO:  
3,940,367, PUB. 1-18-2011. INT. CL. 44.

CORRIGAN, STACY, WOONSOCKET, RI:  
3,940,454, PUB. 1-18-2011. INT. CL. 41.

COSCO MANAGEMENT, INC, WILMINGTON, DE, COSCO,  
INC., COLUMBUS, IN:  
1,635,510, REN. 2-28-11. INT. CL. 20.

COSCO MANAGEMENT, INC., WILMINGTON, DE:  
2,427,392, REN. 2-25-11. INT. CL. 12.

COSMO PRECISION MACHINE INC., JAPAN:  
3,940,047, PUB. 1-18-2011. INT. CL. 28.

COST EFFECTIVE HEALTHCARE INC., KINGSTON, CA-  
NADA:  
3,939,397, PUB. 10-12-2010. INT. CL. 38.

COST PLUS MANAGEMENT SERVICES, INC., OAKLAND,  
CA:  
3,941,787, INT. CL. 3.

COSTQUEST ASSOCIATES, INC., CINCINNATI, OH:  
3,939,801, PUB. 1-18-2011. MULTIPLE CLASS, INT. CLS.  
38 AND 42.

COTTON COUNCIL INTERNATIONAL, WASHINGTON,  
DC:  
3,940,851, PUB. 1-18-2011. INT. CL. 38.

COTY GERMANY GMBH, FED REP GERMANY:  
3,940,063, PUB. 1-18-2011. INT. CL. 3.

COUG & COMPANY INC., BURLINGTON, CANADA:  
3,941,323, INT. CL. 25.

COULBOURN INSTRUMENTS, LLC, HOLLISTON, MA:  
2,925,160, CANC. MULTIPLE CLASS, INT. CLS. 35 AND  
42.

COUNTRY CLUB SUPPLY, INC., ARLINGTON HEIGHTS,  
IL:  
3,939,540, PUB. 1-18-2011. INT. CL. 35.

COUNTRY HOME CREATIONS, INC., GODDRICH, MI:  
2,384,421, REN. 2-26-11. INT. CL. 30.

COUNTRYWIDE VENDING, INC., CANOGA PARK, CA:  
3,939,675, PUB. 1-18-2011. INT. CL. 36.

COUSINS SUBMARINES, INC., MENOMONEE FALLS, WI:  
1,705,595, AM. INT. CL. 42.

COVENANT TRUST COMPANY, CHICAGO, IL:  
2,537,533, REN. 2-26-11. INT. CL. 35.

COVERHOUND, INC., SAN FRANCISCO, CA:  
3,940,823, PUB. 1-18-2011. INT. CL. 35.

COX HOLDINGS, INC., ATLANTA, GA:  
2,369,046, CANC. INT. CL. 42.  
2,433,740, REN. 2-26-11. INT. CL. 42.

CRACIUNESCU, MARIN, SEVEN HILLS, OH:  
2,865,664, CANC. INT. CL. 10.

CRANE CARRIER COMPANY, TULSA, OK:  
1,177,827, REN. 3-3-11. MULTIPLE CLASS, INT. CLS. 7  
AND 12.

CRAYOLA PROPERTIES, INC., EASTON, PA:  
3,942,367, INT. CL. 16.  
3,942,369, INT. CL. 16.

CRAZY TAILS LLC, BUFFALO GROVE, IL:  
3,940,990, INT. CL. 35.

CRC INDUSTRIES, INC., WARMINSTER, PA:  
726,412, REN. 2-25-11. U.S. CL. 6 (INT. CL. 2).

CREANOVATIVE INC., SEOUL, REPUBLIC OF KOREA:  
3,940,124, PUB. 1-18-2011. INT. CL. 9.

CREATIONS MEANDRES INC., MONTREAL, QUEBEC H1Z  
4M6, CANADA:  
2,863,942, CANC. MULTIPLE CLASS, INT. CLS. 21 AND  
25.

- CREATIVE BRAND WORKS, DEXTER, MI:  
3,941,933, INT. CL. 9.
- CREATIVE COMPANY, THE, MANKATO, MN:  
3,941,612, INT. CL. 16.
- CREATIVE OUTDOOR PRODUCTS, INC., CRAWFORDSVILLE, IN:  
3,941,993, INT. CL. 28.
- CREATIVE TRADE WORLD, INC., BEVERLY HILLS, CA:  
3,940,203, PUB. 8-17-2010. MULTIPLE CLASS, INT. CLS. 30 AND 32.
- CREDIT SUISSE SECURITIES (USA) LLC, NEW YORK, NY:  
3,940,912, PUB. 1-18-2011. INT. CL. 36.
- CREEKSIDE MUSHROOMS, LTD, WORTHINGTON, PA, BUTLER COUNTY MUSHROOM FARM, INC., WEST WINFIELD, PA:  
930,109, REN. 3-3-11. U.S. CL. 46 (INT. CL. 31).
- CREGO METAL SYSTEMS, INC., ALBUQUERQUE, NM:  
3,941,585, INT. CL. 6.  
3,941,586, INT. CL. 6.
- CREPE360, LLC, ATLANTA, GA:  
3,941,019, INT. CL. 43.
- CRESTRON ELECTRONICS INC., ROCKLEIGH, NJ:  
3,941,791, INT. CL. 9.
- CRI INTERNATIONAL CORPORATION, BEAVERTON, OR, DBA COMPONENT RESOURCES:  
2,386,876, CANC. INT. CL. 9.
- CRIMAPI HOTELS S.R.L., BARDOLINO (VERONA), ITALY:  
3,942,069, INT. CL. 43.
- CRISA LIBBEY MEXICO, S. DE R.L. DE C.V., 64580 MONTERREY, N.L., MEXICO:  
3,942,032, INT. CL. 21.
- CRISPIN OF LYNN, LLC, NEW YORK, NY:  
3,940,481, PUB. 1-18-2011. INT. CL. 18.
- CRITICAL HEALTH, S.A., P-3045-504 TAVEIRO, COIMBRA, PORTUGAL:  
3,939,926, PUB. 1-18-2011. INT. CL. 9.  
3,939,927, PUB. 1-18-2011. INT. CL. 9.
- CROCKTAIL LLC, WORCESTER, MA:  
3,940,569, PUB. 1-18-2011. INT. CL. 25.
- CROCS, INC., NIWOT, CO:  
3,942,313, INT. CL. 25.
- CROSS, STEVEN MICHAEL, REDLANDS, CA, DBA HEAD-CHANGE INTERNATIONAL:  
3,939,676, PUB. 1-18-2011. INT. CL. 35.
- CROSSVILLE, INC., CROSSVILLE, TN:  
1,636,162, REN. 2-26-11. INT. CL. 19.
- CROTON WATCH COMPANY, INC., MOONACHIE, NJ:  
1,653,014, REN. 2-18-2011. INT. CL. 14.
- CROWLEY CHEMICAL COMPANY, INC., NEW YORK, NY:  
2,864,834, CANC. INT. CL. 1.
- CROWN CHEF, LLC, NEW YORK, NY:  
2,528,153, REN. 2-26-11. INT. CL. 11.  
2,540,934, REN. 2-26-11. INT. CL. 11.
- CROWN CREATIVE CO., LTD., ADACHI-KU; TOKYO 120-0006, JAPAN:  
3,939,895, PUB. 1-18-2011. MULTIPLE CLASS, INT. CLS. 9, 14, 16, 18, 24, 25 AND 28.
- CROWN FOUNDATIONS, INC., BRIDGEPORT, CT:  
1,145,500, REN. 3-3-11. INT. CL. 25.
- CROWN JAPAN CORPORATION, APARTADO 4213 ZONA LIBRE DE COLON, PANAMA:  
1,634,676, REN. 2-26-11. MULTIPLE CLASS, INT. CLS. 9 AND 12.
- CROWNBEAV, LLC, EUGENE, OR:  
3,942,006, MULTIPLE CLASS, INT. CLS. 5 AND 10.
- CRS HOLDINGS, INC., WILMINGTON, DE, CARPENTER TECHNOLOGY CORPORATION, READING, PA:  
907,855, REN. 3-1-11. U.S. CL. 14 (INT. CL. 6).
- CRUSADOR ENTERPRISES, INC., BLACK MOUNTAIN, FL:  
3,940,576, PUB. 1-18-2011. INT. CL. 5.  
3,940,577, PUB. 1-18-2011. INT. CL. 5.
- CRUSHPROOF TUBING COMPANY, MCCOMB, OH:  
908,600, REN. 3-2-11. U.S. CL. 35 (INT. CL. 17).
- CRYPTOZOIC ENTERTAINMENT, LLC, IRVINE, CA:  
3,942,018, MULTIPLE CLASS, INT. CLS. 16 AND 28.
- CRYSTAL CLEAR SPA AND LEISURE PRODUCTS INC., DRAYTON VALLEY, CANADA:  
3,939,412, PUB. 1-18-2011. INT. CL. 16.
- CRYSTAL POINT, INC., SCOTTSDALE, AZ:  
1,643,146, REN. 2-26-11. INT. CL. 9.
- CRYSTAL ROCK LLC, WATERTOWN, CT:  
3,941,673, INT. CL. 35.
- CRYSTALGRIDTOOLS.COM LLC, AUSTIN, TX:  
3,940,113, PUB. 1-18-2011. INT. CL. 19.  
3,940,114, PUB. 1-18-2011. INT. CL. 19.
- CTA RESPONSE GROUP, LLC, BRADFORD, MA:  
3,942,113, INT. CL. 5.
- CTECH AG, CH-7001 CHUR, SWITZERLAND:  
2,865,330, CANC. INT. CL. 8.
- CTEX SEAT COMFORT LIMITED, STAFFORDSHIRE DE13 0BQ, ENGLAND:  
2,864,164, CANC. MULTIPLE CLASS, INT. CLS. 9, 11 AND 12.
- CUBAN CIGAR BRANDS, N.V., FORT LAUDERDALE, FL:  
2,435,147, REN. 2-28-11. INT. CL. 34.
- CUBILLOS, LUIS VICTOR TORREALBA, CURICO, CHILE:  
2,865,834, CANC. INT. CL. 33.
- CULP GROUP, INC., NASHVILLE, TN, DBA PEARL EQUIPMENT COMPANY:  
910,388, REN. 3-3-11. U.S. CL. 23 (INT. CL. 7).
- CULPEPER FARMERS' COOPERATIVE INC., CULPEPER, VA:  
3,941,006, INT. CL. 31.
- CUMMINGS, BRUCE D., EDEN PRAIRIE, MN:  
2,470,318, REN. 2-26-11. INT. CL. 21.
- CURIOSCHAMELEON, LLC, WILLIAMSVILLE, NY:  
2,864,559, CANC. INT. CL. 25.  
2,864,560, CANC. INT. CL. 25.
- CUSTOM FIREPLACE LTD., INC., ST. CLAIR, MO:  
1,423,614, COR. INT. CL. 6.
- CUSTOM MATERIALS, INC., CHAGRIN FALLS, OH:  
2,420,623, REN. 2-28-11. MULTIPLE CLASS, INT. CLS. 9 AND 17.  
2,420,623, AM. MULTIPLE CLASS, INT. CLS. 9 AND 17.
- CUSTOM SELECT REALTY, LLC, LOUISVILLE, KY:  
3,940,615, PUB. 1-18-2011. INT. CL. 36.
- CWE ENTERPRISES, SAN DIEGO, CA, DBA CITYWIDE ELECTRIC DBA CITYWIDE PLUMBING HEATING AIR & ELECTRICAL:  
2,368,404, CANC. INT. CL. 37.
- CYBER-TECH, INC., TIGARD, OR:  
1,675,725, REN. 3-2-11. INT. CL. 9.
- CYBERDEFENDER CORPORATION, LOS ANGELES, CA:  
3,939,546, PUB. 1-18-2011. INT. CL. 9.
- CYBERMARK INTERNATIONAL, INC., PHOENIX, AZ:  
3,942,214, INT. CL. 42.
- CYBEROPTIX, LLC, DETROIT, MI:  
3,940,346, PUB. 1-18-2011. MULTIPLE CLASS, INT. CLS. 25 AND 41.
- CYBOZU, INC., JAPAN:  
3,940,034, PUB. 1-18-2011. MULTIPLE CLASS, INT. CLS. 9 AND 42.
- CYCLE GEAR, INC., BENICIA, CA:  
2,479,455, REN. 2-26-11. INT. CL. 35.
- CYSTIC FIBROSIS FOUNDATION, BETHESDA, MD:  
3,942,116, INT. CL. 36.
- D & P CUSTOM LIGHTS & WIRING SYSTEMS, INC., NASHVILLE, TN:  
3,941,070, MULTIPLE CLASS, INT. CLS. 9 AND 11.
- D B INDUSTRIES, INC., RED WING, MN, DBA CAPITAL SAFETY USA:  
2,458,279, REN. 2-26-11. INT. CL. 9.
- D B INDUSTRIES, INC., RED WING, MN:  
2,462,238, REN. 2-26-11. INT. CL. 9.
- D B INDUSTRIES, INC., RED WING, MN, DBA CAPITAL SAFETY USA:  
2,467,512, REN. 2-25-11. INT. CL. 9.
- D. PAGLIA & SON, INC., MOUNTAINSIDE, NJ:  
3,942,462, INT. CL. 35.
- D. W. SIMPSON & CO., CHICAGO, IL:  
2,448,513, COR. INT. CL. 35.
- D-LITE LLC, LEMONT, IL:  
3,941,606, INT. CL. 20.
- D-M-S HOLDINGS, INC., WAUKEGAN, IL:  
2,430,702, REN. 3-3-11. MULTIPLE CLASS, INT. CLS. 5, 8, 10, 12, 20 AND 21.

DAC GROUP (HOLDINGS) LIMITED, TORONTO, ONTARIO, CANADA:  
3,939,789, PUB. 1-18-2011. INT. CL. 35.

DADCO, INC., CINCINNATI, OH:  
3,940,907, PUB. 1-18-2011. INT. CL. 20.

DAIMLER AG, STUTTGART, FED REP GERMANY:  
3,940,153, PUB. 1-18-2011. MULTIPLE CLASS, INT. CLS. 12, 25, 28, 39 AND 41.

DAINIPPON SUMITOMO PHARMA CO., LTD., OSAKA-SHI, OSAKA, JAPAN:  
2,448,573. REN. 2-26-11. INT. CL. 5.

DAIRY MANAGEMENT, INC., ROSEMONT, IL:  
2,864,612, CANC. INT. CL. 41.

DAKINI MOVEMENT LLC, BERKELEY HEIGHTS, NJ:  
3,940,472, PUB. 1-18-2011. INT. CL. 41.

DAKTRONICS, INC., BROOKINGS, SD:  
2,536,401. REN. 2-26-11. INT. CL. 9.

DAL-TILE CORPORATION, DALLAS, TX TO DAL-ELIT, L.P., DALLAS, TX:  
2,169,908, CANC. INT. CL. 19.

DALY, LOUANN, MARBLEHEAD, MA:  
2,538,624. REN. 3-2-11. MULTIPLE CLASS, INT. CLS. 35 AND 42.

DAMIANI INTERNATIONAL B.V., AMSTERDAM, HOLLAND, NETHERLANDS:  
3,942,378, INT. CL. 14.

DANCE OF LIFE, INC., THE, MIAMI, FL:  
2,432,884, CANC. INT. CL. 16.

DANIEL CABRERA JR, FORT WORTH, TX, DBA REALITY PRODUCTS LLC:  
3,941,998, INT. CL. 5.

DANIEL J. ZEHNDER, NEW BERLIN, WI:  
3,941,659, INT. CL. 9.

DANISCO A/S, DK-1001 COPENHAGEN K, DENMARK:  
3,941,266, INT. CL. 30.

DANNENHOLD, ROBERT, E., SEATTLE, WA:  
2,865,707, CANC. INT. CL. 41.

DANNON COMPANY, INC., THE, WHITE PLAINS, NY:  
2,429,384. REN. 2-26-11. INT. CL. 29.

DANNY HESTER'S PORTABLE GYM, LLC, VENTURA, CA:  
3,941,730, INT. CL. 28.

DANSTAR FERMENT AG, 6301 ZUG, SWITZERLAND:  
2,865,435, CANC. MULTIPLE CLASS, INT. CLS. 1, 5 AND 30.

DAP BRANDS COMPANY, MEDINA, OH:  
3,941,839, INT. CL. 2.

DARING DONUTS LLC, WOODINVILLE, WA:  
3,940,527, PUB. 1-18-2011. INT. CL. 30.

DARLEY B.V., 6245 HZ EIJSDEN, NETHERLANDS:  
2,367,767, CANC. INT. CL. 7.

DARLINGTON COOKIE COMPANY, NOBLESVILLE, IN:  
3,942,014, INT. CL. 30.

DARREL EDWARDS INC., SAN DIEGO, CA:  
3,939,602, PUB. 1-18-2011. INT. CL. 35.

DART CHART SYSTEMS, L.L.C., CEDARBURG, WI:  
2,367,720, CANC. INT. CL. 16.

DATA + IMAGINATION, INC., STUDIO CITY, CA:  
2,864,105, CANC. INT. CL. 9.

DATATREASURY CORPORATION, PLANO, TX:  
2,430,500. REN. 2-26-11. MULTIPLE CLASS, INT. CLS. 9 AND 42.

DATUM FILING SYSTEMS, INC., EMIGSVILLE, PA:  
2,430,682. REN. 2-26-11. MULTIPLE CLASS, INT. CLS. 16 AND 20.

DAVID ALLEN & CO., OJAI, CA:  
2,431,583. REN. 3-3-11. INT. CL. 41.

DAVID BAKER, BEND, OR:  
3,941,294, INT. CL. 36.

DAVID C COOK, COLORADO SPRINGS, CO:  
3,942,037, INT. CL. 9.  
3,942,042, INT. CL. 16.

DAVID J. GEIGER, HAXTUN, CO:  
3,940,080, PUB. 11-30-2010. INT. CL. 14.

DAVID L. OSMENT, LINN CREEK, MO:  
3,939,623, PUB. 1-18-2011. INT. CL. 28.

DAVID MALLETT GROUP SARL, FRANCE:  
3,940,042, PUB. 1-18-2011. MULTIPLE CLASS, INT. CLS. 3, 4, 21 AND 44.

DAVID SUTTIE, NAPA, CA AND ROSANNE SUTTIE, NAPA, CA:  
3,940,772, PUB. 1-18-2011. INT. CL. 44.

DAVIDAN CORPORATION, PHOENIX, AZ:  
3,941,510, INT. CL. 36.

DAVIDS BRIDAL INC, CONSHOHOCKEN, PA:  
2,426,973. REN. 3-2-11. INT. CL. 35.

DAVINCI SELECTWORK LLC, NEW YORK, NY:  
3,939,415, PUB. 1-18-2011. INT. CL. 35.

DAVIS-HOLLANDER, MARGO, ASHLEY FALLS, MA:  
3,939,708, PUB. 1-18-2011. INT. CL. 41.

DAVIS, DEBI, POMPANO BEACH, FL:  
1,902,345, CANC. INT. CL. 5.

DAVIS, LOIS, CROSSVILLE, TN:  
3,940,665, PUB. 1-18-2011. INT. CL. 31.

DAWN FOODS, INC., JACKSON, MI:  
2,865,242, CANC. INT. CL. 30.

DAWSON, JOSEPH H., HOMOSASSA, FL:  
2,455,120. REN. 2-26-11. INT. CL. 35.

DAYLIGHT DONUT FLOUR CO., L.L.C., TULSA, OK:  
3,940,424, PUB. 1-18-2011. INT. CL. 30.

DAYS OF WONDER, INC., LOS ALTOS, CA:  
3,941,788, INT. CL. 28.

DB ORTHODONTICS LTD, SILSDEN, W. YORKSHIRE, UNITED KINGDOM:  
3,942,124, INT. CL. 10.

DB RESEARCH LLP, HARLINGEN, TX:  
3,941,996, INT. CL. 9.

DBA DIRECT, INC., FLORENCE, KY:  
2,522,465. REN. 2-26-11. INT. CL. 42.

DBG GROUP INVESTMENTS, LLC, DALLAS, TX:  
2,864,973, CANC. INT. CL. 11.

DDB WORLDWIDE COMMUNICATIONS GROUP INC., NEW YORK, NY:  
3,941,448, INT. CL. 35.

DE GRENIER, KAREN, PHOENIX, AZ:  
3,940,095, PUB. 1-18-2011. INT. CL. 45.

DEACONS OF DOO-WOP, NORTHVILLE, MI, DBA THE REFLECTIONS:  
3,939,619, PUB. 1-18-2011. MULTIPLE CLASS, INT. CLS. 9 AND 41.

DEARBORN, ASHLEY, NEW YORK, NY:  
2,865,705, CANC. INT. CL. 25.

DECCA MUSIC GROUP LIMITED, LONDON, UNITED KINGDOM:  
3,940,094, PUB. 1-18-2011. INT. CL. 9.

DECOART, INC., STANFORD, KY, CERAMICHROME, INC., STANFORD, KY:  
1,648,481. REN. 3-3-11. INT. CL. 2.

DEERY AMERICAN CORPORATION, GRAND JUNCTION, CO:  
3,940,542, PUB. 1-18-2011. INT. CL. 17.  
3,940,843, PUB. 1-18-2011. INT. CL. 17.  
3,940,846, PUB. 1-18-2011. INT. CL. 17.  
3,940,848, PUB. 1-18-2011. INT. CL. 17.  
3,940,850, PUB. 1-18-2011. INT. CL. 17.  
3,940,856, PUB. 1-18-2011. MULTIPLE CLASS, INT. CLS. 17 AND 19.

DEFINITE BODIES, INC., STATEN ISLAND, NY:  
2,864,600, CANC. INT. CL. 41.

DEGREMONT, FRANCE:  
3,939,937, PUB. 1-18-2011. MULTIPLE CLASS, INT. CLS. 11, 40 AND 42.  
3,939,938, PUB. 1-18-2011. MULTIPLE CLASS, INT. CLS. 11, 40 AND 42.  
3,939,944, PUB. 1-18-2011. MULTIPLE CLASS, INT. CLS. 11, 40 AND 42.  
3,939,945, PUB. 1-18-2011. MULTIPLE CLASS, INT. CLS. 11, 40 AND 42.

DEGREMONT, F-92500 RUEIL MALMAISON, FRANCE:  
3,939,946, PUB. 1-18-2011. MULTIPLE CLASS, INT. CLS. 11, 40 AND 42.

DEL MONTE CORPORATION, SAN FRANCISCO, CA:  
2,431,525. REN. 3-3-11. INT. CL. 29.

DEL-NAT TIRE CORPORATION, MEMPHIS, TN:  
1,635,425. REN. 2-26-11. MULTIPLE CLASS, INT. CLS. 12 AND 42.

- DELAWARE CAPITAL FORMATION, INC., WILMINGTON, DE:  
3,940,958, PUB. 1-18-2011. INT. CL. 35.
- DELFIN DESIGN AND MANUFACTURING, INC., RANCHO SANTA MARGARITA, CA:  
3,939,529, PUB. 1-18-2011. MULTIPLE CLASS, INT. CLS. 20, 21 AND 40.  
3,939,531, PUB. 1-18-2011. MULTIPLE CLASS, INT. CLS. 20, 21 AND 40.
- DELTA EPSILON MU FRATERNITY, BINGHAMTON, NY:  
2,864,267, CANC. U.S. CL. 200.
- DELTA MOON, ATLANTA, GA:  
2,864,265, CANC. INT. CL. 41.
- DELTA TEC B.V., LANDGRAAF, NETHERLANDS:  
2,864,790, CANC. MULTIPLE CLASS, INT. CLS. 1 AND 17.
- DELTATRAK, INC., PLEASANTON, CA:  
2,865,789, CANC. INT. CL. 9.
- DELUSIONAL FILMS, LOS ANGELES, CA:  
2,410,134, REN. 2-25-11. INT. CL. 41.  
2,433,361, REN. 2-25-11. INT. CL. 41.
- DELUXE ENTERPRISE OPERATIONS, INC., SHOREVIEW, MN:  
3,939,769, PUB. 1-18-2011. INT. CL. 16.
- DELUXE MEDIA GROUP LLC, HOLLYWOOD, CA:  
2,480,453, REN. 2-26-11. MULTIPLE CLASS, INT. CLS. 40 AND 42.
- DEMALDERIS, JOSEPH, MILFORD, PA, DBA CROSS CURRENT GUIDE SERVICE:  
3,941,746, INT. CL. 35.
- DEMESA, ARMAN L., CHULA VISTA, CA:  
3,939,409, PUB. 1-18-2011. INT. CL. 41.
- DEMOS, ALEXANDER P., CORONA, CA, DBA GOLF MANAGER ENTERPRISES:  
2,367,520, CANC. INT. CL. 9.
- DEN MAR TRANSIT ENGINEERING, INC., MIAMI, FL, DBA DEN MAR FUSES:  
2,865,053, CANC. INT. CL. 9.
- DENKI KAGAKU KOGYO KABUSHIKI KAISHA, CHUOKU; TOKYO, JAPAN:  
3,939,961, PUB. 1-18-2011. INT. CL. 17.
- DENNIS MURPHY, WALLA WALLA, WA:  
3,942,354, INT. CL. 33.
- DENSELIGHT SEMICONDUCTORS PTE. LTD., SINGAPORE, SINGAPORE:  
2,865,630, CANC. INT. CL. 9.
- DENTAL DECKS, INC, PRINCETON JUNCTION, NJ:  
3,939,364, PUB. 1-18-2011. INT. CL. 16.
- DENTAL LOGIC, LLC, TOLEDO, OH:  
3,940,637, PUB. 1-18-2011. INT. CL. 44.
- DENTBRYTE, LLC, CAMILLA, GA:  
2,864,817, CANC. INT. CL. 35.
- DENTON ENTERPRISES, INC., KNOXVILLE, TN:  
3,940,312, PUB. 1-18-2011. INT. CL. 43.
- DENTSPLY INTERNATIONAL INC., YORK, PA, J. M. NEY COMPANY, THE, BLOOMFIELD, CT:  
912,306, REN. 2-26-11. U.S. CL. 14 (INT. CL. 6).
- DENTSPLY INTERNATIONAL INC., YORK, PA:  
2,478,818, REN. 3-3-11. MULTIPLE CLASS, INT. CLS. 5 AND 10.
- DEPARTMENT OF AGRICULTURE, HONOLULU, HI:  
3,939,639, PUB. 1-18-2011. INT. CL. 35.
- DEPARTMENT OF THE ARMY, WASHINGTON, DC:  
2,434,951, REN. 2-26-11. U.S. CL. 200.
- DEPPEN, DAN, WOODLAND HILLS, CA:  
3,939,457, PUB. 1-18-2011. INT. CL. 9.
- DER GRUNE PUNKT - DUALES SYSTEM DEUTSCHLAND AKTIENGESELLSCHAFT, 51145 KOLN, COLOGNE, FED REP GERMANY:  
2,864,044, CANC. MULTIPLE CLASS, INT. CLS. 16, 35, 36, 37, 39, 40, 41 AND 42.
- DERCO, INC., SAN FRANCISCO, CA:  
1,617,967, REN. 3-2-11. MULTIPLE CLASS, INT. CLS. 37 AND 42.
- DERING CORPORATION, THE, LANCASTER, PA:  
2,863,903, CANC. INT. CL. 21.
- DERMACARE NEUROSCIENCE INSTITUTE, BEVERLY HILLS, CA:  
3,941,053, INT. CL. 3.
- DESBOUILLONS, ROBERTA, SAN FRANCISCO, CA:  
2,664,171, CANC. INT. CL. 41.
- DESERT GLORY, LTD, SAN ANTONIO, TX:  
3,939,430, PUB. 7-20-2010. INT. CL. 31.
- DESERT JET, LLC, THERMAL, CA, DBA DESERT JET:  
3,940,381, PUB. 1-18-2011. INT. CL. 39.
- DESIGN DESIGN, INC., GRAND RAPIDS, MI:  
2,865,698, CANC. INT. CL. 28.
- DESIGNS FOR HEALTH, INC., SUFFIELD, CT:  
3,940,969, PUB. 1-18-2011. INT. CL. 5.
- DESMAISONS, KATHLEEN B., ALBUQUERQUE, NM, DBA RADIANT RECOVERY:  
2,431,448, REN. 2-26-11. INT. CL. 5.
- DESMARAIS, BRENDA, SOUTH WINDSOR, CT:  
3,940,972, PUB. 1-18-2011. INT. CL. 25.
- DESTILERIA SERRALLES, INC., MERCEDITA, PUERTO RICO:  
1,150,590, REN. 3-2-11. INT. CL. 33.
- DESTINATION SEMINARS, LLC, FALLON, NV:  
2,865,677, CANC. INT. CL. 41.
- DETROIT MEDICAL CENTER, DETROIT, MI, AKA DMC:  
3,939,729, PUB. 1-18-2011. INT. CL. 44.
- DEUTSCHE BANK SECURITIES INC., BALTIMORE, MD:  
2,865,350, CANC. INT. CL. 36.
- DEUTSCHE GESELLSCHAFT FÜR NACHHALTIGES BAUEN E.V., STUTTGART, FED REP GERMANY:  
3,939,902, PUB. 1-18-2011. MULTIPLE CLASS, INT. CLS. 35, 37, 41 AND 42.
- DEVICEFIDELITY, INC., RICHARDSON, TX:  
3,941,604, INT. CL. 9.
- DEVIL MOUNTAIN WHOLESALE NURSERY, INC., SAN RAMON, CA:  
3,940,402, PUB. 1-18-2011. INT. CL. 44.
- DEVINE, JAMES D., MURRELLS INLET, SC, DBA U-WINDIT:  
3,940,520, PUB. 1-18-2011. INT. CL. 10.
- DEWI COLLECTION LLC, PALM BEACH, FL, DBA PICKLED PINK:  
3,941,964, MULTIPLE CLASS, INT. CLS. 29 AND 30.
- DFR GROUP, INC., MEDINA, OH:  
2,369,592, CANC. INT. CL. 38.
- DHEVNEY, TRYSHE, TUCSON, AZ:  
2,368,917, CANC. INT. CL. 41.
- DIABCELL PTY LIMITED, SYDNEY, NSW 2000, AUSTRALIA:  
3,939,658, PUB. 1-18-2011. INT. CL. 5.
- DIAGEO IRELAND, DUBLIN 8, IRELAND FROM DIAGEO PLC, LONDON WIM 9AG, UNITED KINGDOM:  
3,940,977, MULTIPLE CLASS, INT. CLS. 6, 20, 41 AND 42.
- DIAGEO NORTH AMERICA, INC., NORWALK, CT:  
3,940,930, PUB. 1-18-2011. INT. CL. 33.
- DIAGEO SCOTLAND LIMITED, EDINBURGH, UNITED KINGDOM, JOHN WALKER & SONS LIMITED, LONDON SW, ENGLAND:  
908,750, REN. 2-26-11. U.S. CL. 49 (INT. CL. 33).
- DIAMOND CHAIN COMPANY INC, INDIANAPOLIS, IN:  
2,466,116, REN. 2-26-11. MULTIPLE CLASS, INT. CLS. 7 AND 12.
- DIAMOND HONG, INC., BROOKLYN, NY:  
3,941,598, INT. CL. 33.
- DIANE UHLENKAMP, AURORA, CO:  
3,941,185, INT. CL. 25.
- DIAZTECA, CO., RIO RICO, AZ:  
2,517,485, REN. 2-26-11. INT. CL. 31.
- DICK CLARK COMPANY, INC., MALIBU, CA:  
2,444,879, REN. 2-26-11. INT. CL. 41.
- DIESTE, ROBERT ANTHONY, DALLAS, TX:  
3,939,653, PUB. 1-18-2011. INT. CL. 41.
- DIGICHART, INC., NASHVILLE, TN:  
2,865,600, CANC. INT. CL. 9.
- DIGITAL MAGNET INC., CHAPEL HILL, NC:  
2,864,726, CANC. INT. CL. 9.
- DIGITAL MARKETING SERVICES, INC., DALLAS, TX:  
2,864,421, CANC. INT. CL. 35.



DIGITALMUNCH LLC, BURBANK, CA:  
3,940,133, PUB. 1-18-2011. INT. CL. 9.

DIGNITY BY DESIGN, LLC, SPRING LAKE PARK, MN:  
2,864,599, CANC. INT. CL. 25.  
2,865,172, CANC. INT. CL. 25.

DIMC, INC., NEWARK, DE:  
2,861,465, CANC. INT. CL. 1.

DIMENSION ONE SPAS, INC., VISTA, CA:  
2,865,823, CANC. INT. CL. 11.

DIMITROV, VLADIMIRE, SEATTLE, WA:  
3,939,718, PUB. 1-18-2011. INT. CL. 43.

DINACELL ELECTRONICA SL, SPAIN:  
3,939,898, PUB. 1-18-2011. MULTIPLE CLASS, INT. CLS. 9, 35 AND 42.

DINEL, 76220 GOURNAY -EN-BRAY, FRANCE:  
2,421,137, REN. 2-28-11. INT. CL. 9.

DINUNZIO, TRACY, SANTA MONICA, CA:  
3,939,651, PUB. 1-18-2011. INT. CL. 35.

DIRANSA SAN LUIS, S.A., BUENOS AIRES, ARGENTINA:  
3,939,760, PUB. 1-18-2011. MULTIPLE CLASS, INT. CLS. 1 AND 2.

DIRECT ENERGY MARKETING LIMITED, TORONTO, ONTARIO, CANADA:  
3,942,052, INT. CL. 37.

DISCOVER MEDIAWORKS, INC., EAGLE RIVER, WI:  
2,488,822, REN. 3-3-11. MULTIPLE CLASS, INT. CLS. 38 AND 41.

DISCUS DENTAL, LLC, CULVER CITY, CA:  
2,437,483, REN. 2-26-11. INT. CL. 42.

DISH NETWORK, L.L.C., ENGLEWOOD, CO:  
3,941,555, INT. CL. 38.  
3,941,556, INT. CL. 41.

DISHMAN, VALLORIE, TEMPLE HILLS, MD, DBA HOSHANNA CREATIONS, INC.:  
3,941,442, INT. CL. 44.

DISNEY ENTERPRISES, INC., BURBANK, CA:  
2,865,712, CANC. INT. CL. 36.  
3,917,336, COR. MULTIPLE CLASS, INT. CLS. 9 AND 16.  
3,941,980, INT. CL. 41.  
3,942,033, INT. CL. 41.  
3,942,335, INT. CL. 21.

DISRUPTIVE LIMITED, BUCKINGHAMSHIRE, UNITED KINGDOM:  
3,940,170, PUB. 1-18-2011. INT. CL. 9.

DISS, INC., NORTH BERGEN, NJ:  
2,540,504, CANC. INT. CL. 25.

DISTEK INTEGRATION, INC., CARTHAGE, IL:  
3,940,798, PUB. 1-18-2011. MULTIPLE CLASS, INT. CLS. 9 AND 42.

DISTILLERIA F.LLI CAFFO S.R.L., LIMBADI (VV), ITALY:  
2,864,897, CANC. INT. CL. 33.

DITECH APPAREL GROUP INC., VANCOUVER, BC, CANADA:  
2,433,990, REN. 3-3-11. INT. CL. 25.

DIVA PROPERTIES, INC., MILLS RIVER, NC, DBA BARKWELLS:  
3,940,842, PUB. 1-18-2011. INT. CL. 43.

DIVERSIFIED ACQUIRING SOLUTIONS, INC, HAUPPAUGE, NY:  
2,865,356, CANC. INT. CL. 35.

DIVERSIFIED CRYOGENICS, INC., BURNSVILLE, MN:  
2,418,844, REN. 3-3-11. INT. CL. 6.

DIVERSIFIED TAPE & GRAPHICS, INC., ITASCA, IL:  
2,524,394, CANC. INT. CL. 16.

DIVOT COMMUNICATION CORPORATION, WAITSFIELD, VT:  
2,368,144, CANC. INT. CL. 16.

DIZY ENTERPRISES, LLC, BENICIA, CA:  
3,939,775, PUB. 1-18-2011. MULTIPLE CLASS, INT. CLS. 41 AND 43.

DM ENTERPRISES & DISTRIBUTORS, INC., MIAMI, FL:  
3,940,389, PUB. 1-18-2011. INT. CL. 32.

DMS HOLDINGS, INC., LAKE FOREST, IL:  
2,865,540, CANC. INT. CL. 10.

DMWS 662 LIMITED, EDINBURGH, UNITED KINGDOM:  
2,864,741, CANC. INT. CL. 12.

DO-GREE FASHIONS LTD., MONTREAL, QUEBEC, CANADA:  
2,369,151, CANC. INT. CL. 25.

DOFASCO INC., HAMILTON, ONTARIO, CANADA:  
2,751,603, CANC. MULTIPLE CLASS, INT. CLS. 1, 4, 6 AND 19.

DOLCE VITA INTIMATES, LLC, HARRISON, NJ:  
2,428,946, REN. 3-2-11. INT. CL. 25.

DOLE FOOD COMPANY, INC., WESTLAKE VILLAGE, CA:  
2,392,196, REN. 3-2-11. INT. CL. 31.

DOLIUM S.A., MENDOZA, ARGENTINA:  
3,941,223, INT. CL. 33.

DOLLAR TREE STORES, INC., CHESAPEAKE, VA:  
3,941,901, INT. CL. 35.

DOMINANT BRANDS LLC, BAYSIDE, NY:  
3,942,301, MULTIPLE CLASS, INT. CLS. 35 AND 36.

DOMINION ENTERPRISES, NORFOLK, VA:  
2,440,123, REN. 3-3-11. INT. CL. 16.  
3,940,776, PUB. 1-18-2011. INT. CL. 35.

DOMOTEC EUROPE LIMITED, TELFORD, SHROPSHIRE, UNITED KINGDOM:  
2,864,148, CANC. INT. CL. 11.

DON SEBASTIANI & SONS INTERNATIONAL WINE NEGOCIANTS, SONOMA, CA:  
3,276,409, CANC. INT. CL. 33.

DON'T PANIC DESIGNS, INC., WEST HOLLYWOOD, CA:  
2,368,230, CANC. INT. CL. 25.

DONATION MATCH, INC., SAN DIEGO, CA:  
3,942,323, INT. CL. 35.

DONG, YONG HUI, NEW YORK, NY:  
3,940,566, PUB. 1-18-2011. MULTIPLE CLASS, INT. CLS. 39 AND 43.

DONNA DECUNZO TADDEO, LIGHTHOUSE POINT, FL:  
3,941,704, INT. CL. 30.

DORIC PRODUCTS, INC., MARSHALL, IL:  
2,432,226, REN. 2-26-11. INT. CL. 19.

DORNIER MEDTECH AMERICA, INC., KENNESAW, GA:  
2,466,902, REN. 2-25-11. INT. CL. 10.

DOS SANTOS, MICHAEL A, STATEN ISLAND, NY:  
2,368,274, CANC. INT. CL. 41.

DOT VEGAS, INC., LAS VEGAS, NV:  
3,939,694, PUB. 1-18-2011. INT. CL. 45.

DOUBLE CRANE ENTERPRISE CO., LTD., TAIPEI, TAIWAN:  
1,638,071, REN. 3-3-11. MULTIPLE CLASS, INT. CLS. 5 AND 30.

DOUG ANDREWS HEATING & VENTILATION LIMITED, WHANGAREI, NEW ZEALAND:  
3,941,320, INT. CL. 11.

DOUGLAS WILLIAMS, LOS ANGELES, CA:  
3,940,510, PUB. 1-18-2011. INT. CL. 35.

DOVER DOWNS GAMING & ENTERTAINMENT, INC., WILMINGTON, DE:  
2,466,838, REN. 3-1-11. INT. CL. 42.

DOW AGROSCIENCES LLC, INDIANAPOLIS, IN:  
3,941,071, INT. CL. 5.

DOYLE'S VALVES, INC., HOUSTON, TX, DBA DOYLES:  
3,941,130, MULTIPLE CLASS, INT. CLS. 7, 9, 35, 37 AND 42.

DR. FRESH, INC., BUENA PARK, CA:  
3,939,587, PUB. 1-18-2011. INT. CL. 3.

DR. ING. H.C.F. PORSCHE AKTIENGESELLSCHAFT, 70435 STUTTGART-ZUFFENHAUSEN, FED REP GERMANY, FIRMA DR. ING. H.C.F. PORSCHE KG, STUTTGART-ZUFFENHAUSEN, FED REP GERMANY:  
904,186, REN. 3-2-11. MULTIPLE CLASS, U.S. CLS. 19 (INT. CL. 12) AND 23 (INT. CL. 12).

DR. PEZO, LLC, BOCA RATON, FL:  
3,940,724, PUB. 1-18-2011. INT. CL. 28.

DR. SEUSS ENTERPRISES, L.P., LA JOLLA, CA:  
2,369,016, CANC. INT. CL. 25.

DR. WOODS PRODUCTS, LLC, ALBANY, NY:  
3,940,296, PUB. 1-18-2011. INT. CL. 3.

DRAEGER MEDICAL GMBH, LUBECK, FED REP GERMANY:  
2,864,040, CANC. INT. CL. 10.

- DRAKE ENTERPRISES INCORPORATED, FAIRFIELD, CA, AKA BIG D PRODUCTS:  
1,148,432. REN. 3-3-11. INT. CL. 18.  
1,153,162. REN. 3-3-11. INT. CL. 18.
- DRAKE ENTERPRISES, INCORPORATED, FAIRFIELD, CA, AKA BIG D PRODUCTS:  
1,148,433. REN. 3-3-11. INT. CL. 18.
- DRAXIS PHARMA GENERAL PARTNERSHIP, KIRKLAND, CANADA:  
2,533,250. REN. 3-2-11. MULTIPLE CLASS, INT. CLS. 35, 39, 40 AND 42.
- DREAM STREET GRAPHIC, INC., INDIANAPOLIS, IN:  
3,939,570, PUB. 1-18-2011. MULTIPLE CLASS, INT. CLS. 37 AND 42.  
3,939,571, PUB. 1-18-2011. MULTIPLE CLASS, INT. CLS. 37 AND 42.
- DREAMWORKS ANIMATION L.L.C., GLENDALE, CA:  
2,865,457. CANC. MULTIPLE CLASS, INT. CLS. 9, 16, 25 AND 28.  
2,865,459. CANC. MULTIPLE CLASS, INT. CLS. 9, 16, 25 AND 28.
- DREAMWORKS L.L.C., GLENDALE, CA:  
2,369,408. CANC. INT. CL. 9.
- DREXEL CHEMICAL COMPANY, MEMPHIS, TN, ANSUL COMPANY, THE, MARINETTE, WI:  
919,659. REN. 3-2-11. U.S. CL. 6 (INT. CL. 1).
- DREXEL UNIVERSITY, PHILADELPHIA, PA:  
2,426,649. REN. 2-25-11. MULTIPLE CLASS, INT. CLS. 41 AND 42.  
2,426,650. REN. 2-25-11. MULTIPLE CLASS, INT. CLS. 41 AND 42.
- DRG INTERNATIONAL, INC., MOUNTAINSIDE, NJ:  
3,941,624, MULTIPLE CLASS, INT. CLS. 9 AND 10.  
3,941,625, MULTIPLE CLASS, INT. CLS. 9 AND 10.
- DRI-AIR INDUSTRIES, INC., EAST WINDSOR, CT:  
1,635,900. REN. 3-3-11. INT. CL. 1.
- DRISSEQ, NADINE, RENTON, WA:  
3,941,614. INT. CL. 3.
- DRIVECAM, INC., SAN DIEGO, CA:  
3,941,571. INT. CL. 45.
- DRKOO.COM, INC., AUSTIN, TX TO VITACOST HOLDINGS, INC., ARLINGTON, VA:  
2,368,069. CANC. MULTIPLE CLASS, INT. CLS. 35, 36 AND 42.
- DRUMMOND GROUP INC., FORTH WORTH, TX:  
2,864,142. CANC. INT. CL. 42.
- DRY-LAM, LLC, KANSAS CITY, MO:  
2,367,600. CANC. INT. CL. 16.
- DSHEALTHCARE INC., YORK, PA:  
3,940,436. PUB. 1-18-2011. INT. CL. 3.
- DTM LTD., WOODLAND, WA:  
3,941,150. INT. CL. 28.
- DUALSTAR ENTERTAINMENT GROUP, LLC, CULVER CITY, CA:  
2,864,180. CANC. MULTIPLE CLASS, INT. CLS. 3, 6, 9, 11, 14, 16, 18, 24, 25, 26, 28, 35 AND 41.
- DUBAI INTERNATIONAL CAPITAL LLC, DUBAI, UNITED ARAB EMIR.:  
3,939,891, PUB. 1-18-2011. MULTIPLE CLASS, INT. CLS. 35 AND 36.
- DUBOC, CAROL, LOS ANGELES, CA:  
3,940,110, PUB. 1-18-2011. MULTIPLE CLASS, INT. CLS. 38 AND 41.
- DUEL CO., INC., FUKUOKA, JAPAN:  
2,439,431. REN. 3-2-11. INT. CL. 28.
- DUGGAN'S DISTILLERS PRODUCTS CORPORATION, BLAUVELT, NY:  
2,431,621. REN. 2-26-11. INT. CL. 33.
- DUKE IMPORTS, INC., ANGOLA, IN:  
3,940,140, PUB. 1-18-2011. INT. CL. 24.
- DUNLOP SLAZENGER GROUP LIMITED, BUCKINGHAMSHIRE, UNITED KINGDOM:  
2,416,371. CANC. INT. CL. 28.
- DUNN, DANIEL A, HOUSTON, TX:  
3,940,762, PUB. 1-18-2011. INT. CL. 41.
- DUPITON, DARNLEY, RICHMOND HILL, NY:  
3,941,859, INT. CL. 41.
- DURACO, INC., FOREST PARK, IL:  
2,426,526. REN. 2-25-11. INT. CL. 17.
- DURGATRONICS MANUFACTURING COMPANY, HONG KONG, HONG KONG:  
3,727,175. CANC. INT. CL. 9.
- DURR MARKETING MANAGEMENT INC., PEORIA, IL:  
3,939,554, PUB. 1-18-2011. INT. CL. 28.
- DURRELL, CHRISTOPHER, BALTIMORE, MD:  
3,940,781, PUB. 1-18-2011. INT. CL. 14.
- DYKOWSKY, DONNY, H., SUFFERN, NY:  
2,865,641. CANC. INT. CL. 41.
- DYMEDIX, CORP., MINNEAPOLIS, MN:  
2,431,459. REN. 2-26-11. INT. CL. 10.
- DYNAMETRIC, INC., ARCADIA, CA:  
2,431,362. REN. 2-26-11. INT. CL. 9.
- DYNAMIC SOLUTIONS INTERNATIONAL CORP., ENGLEWOOD, CO:  
2,367,798. CANC. INT. CL. 9.
- DYNAPAR CORPORATION, GURNEE, IL, ACME-CLEVELAND CORPORATION, THE, MENTOR, OH:  
1,647,937. REN. 2-25-11. INT. CL. 9.
- DYNAWAVE INCORPORATED, HAVERHILL, MA:  
3,941,928. INT. CL. 9.
- DYSLEXIC LAB LLC, NORWALK, CA, DBA DYSLEXIC LAB LLC:  
3,940,205, PUB. 1-18-2011. INT. CL. 25.
- D41E, LLC, JEFFERSONVILLE, IN:  
3,941,414. INT. CL. 5.
- E & H DISTRIBUTING, LLC, ROSEMONT, IL:  
3,941,922. INT. CL. 29.
- E CRAFTSMEN CORPORATION, WATERLOO, ONTARIO, CANADA. SAYERS & ASSOCIATES LIMITED, MISSISSAUGA, ONTARIO L5N 2X6, CANADA:  
2,376,727. REN. 2-26-11. MULTIPLE CLASS, INT. CLS. 9, 40 AND 42.
- E. I. DU PONT DE NEMOURS AND COMPANY, WILMINGTON, DE:  
2,434,020. REN. 3-2-11. INT. CL. 9.
- E. MISHAN & SONS, INC., NEW YORK, NY:  
3,942,252. INT. CL. 7.
- E.B. "HUTT" BUSH, JR., BEVERLY HILLS, CA:  
3,942,015. MULTIPLE CLASS, INT. CLS. 16 AND 35.
- E.O. WOOD CO., INC., FORT WORTH, TX:  
2,370,644. REN. 2-28-11. INT. CL. 17.  
2,370,645. REN. 2-28-11. INT. CL. 17.
- E.ON CLIMATE & RENEWABLES NORTH AMERICA, LLC, AUSTIN, TX:  
3,942,399. INT. CL. 40.  
3,942,414. INT. CL. 40.  
3,942,415. INT. CL. 40.  
3,942,416. INT. CL. 40.  
3,942,417. INT. CL. 40.  
3,942,418. INT. CL. 40.  
3,942,419. INT. CL. 40.  
3,942,420. INT. CL. 40.  
3,942,421. INT. CL. 40.
- E.T.I. ENTE TABACCHI ITALIANI, ROMA, ITALY TO MANIFATTURE SIGARO TOSCANO S.P.A., ROME, ITALY:  
2,538,816. CANC. INT. CL. 34.
- E.V.I. COSMETICS GMBH, 82061 NEURIED, FED REP GERMANY:  
3,940,000, PUB. 1-18-2011. MULTIPLE CLASS, INT. CLS. 3, 5 AND 21.
- E-SELEX.COM, SAN DIEGO, CA:  
2,436,038. REN. 2-26-11. INT. CL. 35.
- EAGLE EYEWEAR, INC., WHITEHOUSE, NJ:  
3,939,716, PUB. 1-18-2011. INT. CL. 9.
- EARL DIDIER DAGUENEAU, ST-ANDELAIN, FRANCE:  
3,939,773, PUB. 1-18-2011. INT. CL. 33.  
3,939,774, PUB. 1-18-2011. INT. CL. 33.
- EASEL, MARLBOROUGH, MA:  
3,940,173, PUB. 10-19-2010. INT. CL. 36.
- EAST COAST GIRLS LTD., SARATOGA SPRINGS, NY:  
3,942,270, MULTIPLE CLASS, INT. CLS. 16 AND 35.
- EAST PARK RESEARCH, INC., HENDERSON, NV:  
2,368,452. CANC. INT. CL. 5.

EAST WEST MANUFACTURING LLC, ATLANTA, GA:  
3,940,271, PUB. 1-18-2011. MULTIPLE CLASS, INT. CLS.  
40 AND 42.

EASTMAN-TODD WELSH, INC., NEW YORK, NY:  
2,865,015, CANC. INT. CL. 25.

EASY PEASY, LLC, SANTA MONICA, CA:  
3,941,772, INT. CL. 16.

EASYGROUP IP LICENSING LIMITED, CAMDEN, LON-  
DON, NW1 7DL, UNITED KINGDOM:  
2,863,969, CANC. MULTIPLE CLASS, INT. CLS. 3, 9, 14,  
16, 18, 28, 29, 30, 32, 33, 34, 35, 38, 39, 41 AND 42.

EBSCO INDUSTRIES, INC., BIRMINGHAM, AL, MILITARY  
SERVICE COMPANY, THE, BIRMINGHAM, AL:  
552,753, REN. 3-2-11. U.S. CL. 32 (INT. CL. 20).

ECCA ENTERPRISES, INC., SAN ANTONIO, TX:  
3,939,474, PUB. 1-18-2011. INT. CL. 9.  
3,939,539, PUB. 1-18-2011. INT. CL. 9.

ECCO EQUIPMENT CORPORATION, SANTA ANA, CA:  
2,435,233, REN. 3-3-11. INT. CL. 37.  
2,435,280, REN. 3-3-11. INT. CL. 37.

ECHO LAKE INDUSTRIES, LTD., PLAINVIEW, NY:  
2,370,118, CANC. INT. CL. 25.

ECI TELECOM LTD., PETACH TIVKA, ISRAEL:  
2,432,519, REN. 3-2-11. INT. CL. 9.

ECO WINDOW SYSTEMS, LLC, MEDLEY, FL:  
3,940,159, PUB. 1-18-2011. INT. CL. 6.

ECO-CLEAN INCORPORATED, SPRINGFIELD, IL:  
2,367,840, CANC. INT. CL. 39.  
2,367,841, CANC. INT. CL. 39.

ECOLAB INC., ST. PAUL, MN:  
2,864,795, CANC. MULTIPLE CLASS, INT. CLS. 1, 7 AND  
41.

ECONOMIC DEVELOPMENT CORPORATION OF LOS  
ANGELES, LOS ANGELES, CA:  
2,384,154, REN. 3-2-11. INT. CL. 35.

ECONOMY NOVELTY & PRINTING ENTERPRISES, INC.,  
NEW YORK, NY:  
2,368,194, CANC. INT. CL. 35.

ECOSERVICES GROUP, DURHAM, NH:  
3,939,848, PUB. 1-18-2011. INT. CL. 2.

ECOTRUST, PORTLAND, OR:  
2,918,420, CANC. MULTIPLE CLASS, INT. CLS. 35 AND  
41.  
2,918,420, COR. MULTIPLE CLASS, INT. CLS. 16, 25, 26  
AND 45.

ECOWATER SYSTEMS LLC, WOODBURY, MN:  
2,368,155, CANC. MULTIPLE CLASS, INT. CLS. 37, 39  
AND 42.

ECS DO BRASIL METALURGIA E PARTICIPAÇÕES LTDA.,  
CACHOEIRINHA, BRAZIL:  
3,940,503, PUB. 1-18-2011. INT. CL. 7.

EDELMAN, INC., CHICAGO, IL:  
3,940,329, PUB. 1-18-2011. INT. CL. 35.

EDGEWATER ASSOCIATES, INC., ATLANTA, GA:  
2,431,901, REN. 2-26-11. INT. CL. 9.

EDISOFT INC., SCARBOROUGH, ONTARIO MIX 1C3,  
CANADA:  
2,482,797, REN. 2-26-11. INT. CL. 9.

EDITIONS ALVIK, 75005 PARIS, FRANCE:  
2,864,082, CANC. MULTIPLE CLASS, INT. CLS. 16, 35, 38,  
41 AND 42.

EDWARD D. JONES & CO. LP, ST. LOUIS, MO:  
2,865,701, CANC. INT. CL. 36.

EDWARDS, ALLEN, WOODLAND HILLS, CA:  
1,636,620, REN. 2-25-11. INT. CL. 3.

EILEEN FISHER, INC., NEW YORK, NY:  
3,941,655, INT. CL. 35.

EKC TECHNOLOGY, INC., HAYWARD, CA:  
2,432,179, REN. 3-2-11. INT. CL. 1.

EKL AG, 88299 LEUTKIRCH, FED REP GERMANY:  
2,863,981, CANC. MULTIPLE CLASS, INT. CLS. 6, 9, 11,  
40 AND 42.

EL INTERNATIONAL CO. LTD., SEOUL, REPUBLIC OF  
KOREA:  
2,864,605, CANC. INT. CL. 25.

EL PASO ELECTRIC COMPANY, EL PASO, TX:  
2,433,035, REN. 3-2-11. INT. CL. 39.

ELECTROLUX HOME PRODUCTS, INC., CLEVELAND,  
OH:  
3,941,143, MULTIPLE CLASS, INT. CLS. 7 AND 11.  
3,941,144, MULTIPLE CLASS, INT. CLS. 7 AND 11.

ELECTRONIC ARTS INC., REDWOOD CITY, CA:  
2,864,851, CANC. INT. CL. 35.

ELENCO ELECTRONICS, INC., WHEELING, IL:  
3,940,898, PUB. 1-18-2011. INT. CL. 28.

ELEVATE REAL ESTATE, INC., SALT LAKE CITY, UT:  
3,940,897, PUB. 1-18-2011. MULTIPLE CLASS, INT. CLS.  
36 AND 37.

ELI LILLY AND COMPANY, INDIANAPOLIS, IN:  
2,430,960, REN. 2-26-11. INT. CL. 42.

ELIXIR PHARMACEUTICALS, INC., CAMBRIDGE, MA:  
2,864,893, CANC. INT. CL. 42.

ELIZABETH ARDEN, INC., MIAMI LAKES, FL:  
2,865,155, CANC. INT. CL. 3.

ELK & ELK CO., LTD., MAYFIELD, OH:  
3,941,955, INT. CL. 45.

ELLIOTT, RICK, FLORENCE, AL:  
2,431,685, REN. 2-26-11. INT. CL. 42.

ELMASSIAN, RICHARD, MONROVIA, CA:  
2,283,633, CANC. INT. CL. 14.

ELMER'S PRODUCTS, INC., COLUMBUS, OH:  
3,942,280, INT. CL. 16.

ELMORE SPORTS GROUP, INC., WEST VALLEY CITY, UT:  
2,538,351, REN. 3-2-11. INT. CL. 41.

ELUCIDA RESEARCH LLC, BEVERLY, MA:  
2,865,379, CANC. INT. CL. 42.

ELVIS PRESLEY ENTERPRISES, INC., MEMPHIS, TN:  
2,434,179, REN. 2-25-11. INT. CL. 21.  
3,941,227, INT. CL. 25.  
3,941,229, INT. CL. 25.

ELYSE CARDON PHOTOGRAPHY LLC, VIRGINIA BEACH,  
VA:  
3,940,608, PUB. 1-18-2011. INT. CL. 41.

ELZA MUELLER-ROEMER, SUMMERVILLE, SC:  
2,368,339, CANC. INT. CL. 41.

EMC CORPORATION, HOPKINTON, MA:  
3,941,237, INT. CL. 9.  
3,941,238, INT. CL. 42.  
3,941,542, INT. CL. 42.

EMERALD METALS LLC, HOUSTON, TX:  
3,941,458, INT. CL. 6.

EMERGING MARKETS INTERNATIONAL GROUP LLC,  
PORT CHESTER, NY, DBA EMERINT:  
3,940,820, PUB. 1-18-2011. INT. CL. 36.

EMERSON ELECTRIC CO., ST. LOUIS, MO:  
1,618,197, REN. 2-28-11. INT. CL. 11.

EMILIO'S TERRACE VINEYARDS, MENLO PARK, CA:  
2,494,140, REN. 3-2-11. INT. CL. 33.

EMPHASYS COMPUTER SOLUTIONS, INC., PETOSKEY,  
MI:  
3,940,399, PUB. 1-18-2011. MULTIPLE CLASS, INT. CLS.  
36 AND 42.

EMPIONEER CORPORATION, LA PUENTE, CA:  
3,941,004, INT. CL. 9.

EMPIRE FOAM, LLC, WINTER GARDEN, FL:  
3,941,620, INT. CL. 19.

EMPLIFY, INC., MENDENHALL, MS:  
2,865,631, CANC. INT. CL. 9.

EMPLOYMENTGROUP, BATTLE CREEK, MI:  
2,368,326, CANC. INT. CL. 36.

EMPSON & CO. S.P.A., ITALY AND CASA VINICOLA  
CANELLA S.P.A., ITALY:  
3,940,014, PUB. 1-18-2011. MULTIPLE CLASS, INT. CLS.  
32, 33 AND 35.

EMSLAND-STÄRKE GMBH, FED REP GERMANY:  
3,787,678, CANC. IIRN. RESTORED TO S.N. 79-074,644.

EMUGE-WERK RICHARD GLIMPEL; GMBH & CO. KG;  
FABRIK FÜR PRÄZISIONSWERKZEUGE, 91207 LAUF,  
FED REP GERMANY:  
3,939,978, PUB. 1-18-2011. INT. CL. 7.

EMUSIC.COM INC., NEW YORK, NY:  
3,940,156, PUB. 1-18-2011. INT. CL. 41.

ENCORE HEALTH RESOURCES, HOUSTON, TX:  
3,940,674, PUB. 1-18-2011. INT. CL. 42.

- ENCORE MEDICAL ASSET CORPORATION, HENDERSON, NV:  
2,368,547, CANC. INT. CL. 10.
- ENCORE MEDICAL ASSET CORPORATION, VISTA, CA:  
2,511,545, REN. 3-3-11. INT. CL. 5.
- ENCORE SOFTWARE, INC., EL SEGUNDO, CA:  
2,374,704, REN. 3-2-11. INT. CL. 9.
- ENCRYPTANET, INC., ANAHEIM, CA:  
3,559,170, COR. MULTIPLE CLASS, INT. CLS. 9, 36, 38 AND 45.
- ENDGAME ENTERPRISES, LLC, WESTMINSTER, CO:  
3,942,374, INT. CL. 41.
- ENER US TRADEMARK LTD., OAKVILLE, ONTARIO, CANADA, DBA NANO TECHNOLOGIES:  
3,939,419, PUB. 1-18-2011. INT. CL. 5.
- ENERCON GMBH, 26605 AURICH, FED REP GERMANY:  
2,863,944, CANC. MULTIPLE CLASS, INT. CLS. 7, 9, 11, 37 AND 42.
- ENERGYNET.COM, INC., AMARILLO, TX:  
2,539,051, REN. 2-26-11. INT. CL. 35.
- ENERTEC ENTERPRISES, LTD., KOWLOON, HONG KONG:  
3,941,862, INT. CL. 28.
- ENERTECH MANUFACTURING, LLC, GREENVILLE, IL:  
3,940,966, PUB. 1-18-2011. INT. CL. 11.
- ENGAGE HEALTHCARE COMMUNICATIONS, LLC, MONROE TWP., NJ:  
3,942,361, INT. CL. 41.
- ENGAGE TECHNOLOGIES, INC, BROOKLYN PARK, MN:  
2,413,400, REN. 2-26-11. INT. CL. 9.
- ENGENIUS, INC., LIVONIA, MI:  
2,863,954, CANC. INT. CL. 9.
- ENGINE, LLC, GLEN ELLYN, IL:  
3,940,372, PUB. 1-18-2011. MULTIPLE CLASS, INT. CLS. 35 AND 45.  
3,940,373, PUB. 1-18-2011. MULTIPLE CLASS, INT. CLS. 35, 36 AND 45.  
3,940,374, PUB. 1-18-2011. MULTIPLE CLASS, INT. CLS. 35, 36 AND 45.
- ENGINEERED DATA PRODUCTS HOLDINGS, INC., BROOMFIELD, CO:  
2,865,643, CANC. MULTIPLE CLASS, INT. CLS. 37 AND 42.
- ENGLAND'S STOVE WORKS, INC., MONROE, VA, ENGLAND; ROBERT S., MADISON HEIGHTS, VA, DBA ENGLAND'S WELDING SERVICE:  
1,147,591, REN. 2-25-11. INT. CL. 11.
- ENGLISH COLLECTABLES, LLC, MURFREESBORO, TN:  
2,864,202, CANC. INT. CL. 21.
- ENGRAPH, L.L.C., LAWRENCE, KS TO ENGRAPH, L.L.C., LAWRENCE, KS:  
2,490,469, CANC. INT. CL. 42.
- ENIX CORPORATION, TOKYO, JAPAN TO KABUSHIKI KAISHA SQUARE ENIX HOLDINGS (ALSO TRADING AS SQUARE ENIX HOLDINGS CO., LTD.), TOKYO, JAPAN:  
2,369,262, CANC. INT. CL. 9.
- ENOTRIA ITALIA DI FRANCESCO CHIERICATI, VICENZA (VD), ITALY:  
3,939,993, PUB. 1-18-2011. INT. CL. 29.
- ENOVA SYSTEMS, INC., TORRANCE, CA:  
2,948,289, AM. MULTIPLE CLASS, INT. CLS. 9, 12, 40 AND 42.
- ENTERTAINMENT BEVERAGES DISTILLERS, LLC, NORWOOD, MA:  
3,941,264, INT. CL. 40.
- ENTITY, INC., MERCER ISLAND, WA, VIVIANE WOODARD INDUSTRIES LTD., VAN NUYS, CA:  
1,610,979, REN. 3-1-11. INT. CL. 3.
- ENTRUST FEDERAL CREDIT UNION, RICHMOND, VA:  
3,939,537, PUB. 1-18-2011. INT. CL. 36.
- ENVASADORA AGUIDA, S.A. DE C.V., SAN LUIS DE LA PAZ, GUANAJUATO, MEXICO:  
2,864,111, CANC. MULTIPLE CLASS, INT. CLS. 29 AND 32.
- ENVIROHOLD, INC, NAPLES, FL:  
3,940,925, PUB. 1-18-2011. INT. CL. 1.
- ENVIRONMENTAL & TURF SERVICES, INC., WHEATON, MD:  
3,940,231, PUB. 1-18-2011. INT. CL. 35.
- ENVIRONMENTAL INDUSTRY ASSOCIATIONS, WASHINGTON, DC:  
3,941,196, MULTIPLE CLASS, INT. CLS. 9, 16, 35, 37, 40 AND 41.
- ENVIRONMENTAL PRODUCTS OF MN, INC., EDINA, MN:  
3,940,885, PUB. 1-18-2011. INT. CL. 11.
- ENVIRONMENTAL QUALITY MANAGEMENT, INC., CINCINNATI, OH:  
2,429,211, REN. 2-26-11. MULTIPLE CLASS, INT. CLS. 37 AND 42.
- ENVIRONMENTAL SOLUTIONS GROUP, LLC, GREENSBORO, NC:  
3,940,288, PUB. 1-18-2011. INT. CL. 42.
- ENVIRONMENTALLY SAFE SYSTEMS, INC., SANTA BARBARA, CA:  
2,613,831, CANC. INT. CL. 5.
- ENVIVA, LP, RICHMOND, VA:  
3,939,783, PUB. 1-18-2011. INT. CL. 40.
- ENZO BIOCHEM, INC., FARMINGDALE, NY:  
2,429,386, REN. 2-26-11. MULTIPLE CLASS, INT. CLS. 1 AND 5.
- EPICORE BIONETWORKS INC., EASTHAMPTON, NJ:  
3,941,766, INT. CL. 1.
- EPISENCIAL, LLC, LOS ANGELES, CA:  
3,941,381, INT. CL. 44.
- EQUALLOGIC, INC., NASHUA, NH:  
2,865,786, CANC. INT. CL. 9.
- EQUIOM, INC., BELLEVUE, WA:  
3,939,791, PUB. 1-18-2011. INT. CL. 42.
- ER ASSETS, LP, FT. LAUDERDALE, FL:  
2,864,537, CANC. MULTIPLE CLASS, INT. CLS. 35 AND 37.
- ERA FRANCHISE SYSTEMS LLC, PARSIPPANY, NJ:  
1,646,268, REN. 3-3-11. INT. CL. 36.  
2,464,187, REN. 2-25-11. INT. CL. 36.  
2,477,197, REN. 3-1-11. INT. CL. 36.
- ERIC HENNING, BRONSON, IA, DBA COLLEGE PRODUCTS INC.:  
3,940,313, PUB. 1-18-2011. INT. CL. 20.
- ERIK M KOZIEJA, HAZELWOOD, MO:  
3,940,819, PUB. 1-18-2011. INT. CL. 41.
- ERNIE PARKER PRODUCTS, INC., CORDOVA, TN:  
3,940,423, PUB. 1-18-2011. INT. CL. 28.
- ERNST MUHLBAUER GMBH & CO, KG, D-25870 NORDER-FRIEDRICHSKOOG, FED REP GERMANY:  
2,864,161, CANC. INT. CL. 10.
- ES/EX CORPORATION, SOUTH SAN FRANCISCO, CA:  
3,942,334, INT. CL. 33.
- ESARESS INTERNATIONAL S.A.R.L., LUXEMBOURG, LUXEMBOURG:  
2,489,945, REN. 3-2-11. INT. CL. 16.
- ESCUELA DE AGRICULTURA DE LA REGION TROPICAL HUMEDA, SAN JOSE, COSTA RICA:  
3,940,721, PUB. 1-18-2011. INT. CL. 41.
- ESH STRATEGIES BRANDING LLC, SPARTANBURG, SC:  
2,457,084, REN. 2-26-11. INT. CL. 42.
- ESPADRILLES BANYOLES, S.L., BANYOLES, GIRONA, SPAIN:  
3,942,355, MULTIPLE CLASS, INT. CLS. 18 AND 25.
- ESQUIRE INNOVATIONS, INC., TEMECULA, CA:  
3,941,876, INT. CL. 9.
- ESTILL MEDICAL TECHNOLOGIES, INC., DALLAS, TX:  
2,471,331, REN. 2-26-11. INT. CL. 10.
- ETI GIDA; SANAYI VE TICARET ANONIM SIRKETI, ESKISEHIR, TURKEY:  
3,939,959, PUB. 1-18-2011. INT. CL. 30.
- ETI SOUND SYSTEMS, INC., HUNTINGTON PARK, CA:  
3,941,648, INT. CL. 9.
- EURO CAFE CORPORATION, STERLING, VA:  
2,429,882, REN. 2-28-11. INT. CL. 42.
- EUROCOPTER, 13725 MARIIGNANE CEDEX, FRANCE:  
2,439,796, REN. 2-26-11. MULTIPLE CLASS, INT. CLS. 12, 28 AND 37.
- EUTELSAT S.A., 75015 PARIS, FRANCE:  
2,868,318, CANC. MULTIPLE CLASS, INT. CLS. 9, 35, 37,

39 AND 41.  
2,868,319, CANC. MULTIPLE CLASS, INT. CLS. 9, 35, 37,  
39 AND 41.

EVANGELOS KARPOUZIS, MINDEN, NV:  
2,530,179, REN. 2-26-11, INT. CL. 42.

EVANS, COLLIN CHARLES, COLUMBUS, OH:  
2,864,472, CANC. INT. CL. 14.

EVANS, KATHLEEN, SUSAN, VAN NUYS, CA:  
2,865,743, CANC. INT. CL. 9.

EVELYN'S KITCHEN, INC., NEW YORK, NY:  
3,940,729, PUB. 1-18-2011, INT. CL. 43.

EVERBANK, JACKSONVILLE, FL:  
3,940,874, PUB. 1-18-2011, INT. CL. 36.  
3,940,918, PUB. 1-18-2011, INT. CL. 36.

EVERBLUE ENERGY, INC., HUNTERSVILLE, NC:  
3,940,448, PUB. 1-18-2011, MULTIPLE CLASS, INT. CLS.  
41 AND 42.

EVERGREEN NURSERY COMPANY, INC., STURGEON  
BAY, WI:  
2,432,154, REN. 2-26-11, INT. CL. 31.

EVERLAST CLIMBING INDUSTRIES, INC., CHATTANOOGA,  
GA, TN:  
1,662,209, REN. 2-25-11, INT. CL. 7.

EVERLY, LLC, BATTLE GROUND, WA:  
3,941,195, INT. CL. 41.

EVONIK INDUSTRIES AG, ESSEN, FED REP GERMANY:  
3,443,469 NEW CERT. 4-5-2011, INT. CL. 2.  
3,533,051, COR. INT. CL. 1.

EVP INTERNATIONAL, LLC, LOVELAND, OH:  
3,942,173, INT. CL. 2.

EVRIHOLDER PRODUCTS LLC, ANAHEIM, CA:  
3,941,969, INT. CL. 8.  
3,942,197, INT. CL. 21.

EWING, LYNN A., SAN DIEGO, CA, DBA GIBNOW.COM:  
3,940,332, PUB. 1-18-2011, INT. CL. 45.

EXCELL MARBLE AND GRANITE, INC., ST. PETERS-  
BURG, FL:  
3,941,898, INT. CL. 11.

EXHALE INC., LENEXA, KS:  
3,940,955, PUB. 1-18-2011, INT. CL. 44.

EXHART ENVIRONMENTAL SYSTEMS, INC., CANOGA  
PARK, CA:  
2,474,432, REN. 2-26-11, INT. CL. 9.

EXHIBITOR PUBLICATIONS, INC., ROCHESTER, MN:  
3,940,787, PUB. 1-18-2011, INT. CL. 41.

EXIT, LTD., LINDEN, NJ:  
3,940,992, INT. CL. 3.

EXPERION, INC., MAPLE, ONATRIO, CANADA, DBA  
SOCIAL GRAPH STUDIOS:  
3,940,786, PUB. 1-18-2011, INT. CL. 42.  
3,940,863, PUB. 1-18-2011, INT. CL. 42.

EXPLORE INFORMATION SERVICES, LLC, EAGAN, MN:  
2,865,693, CANC. INT. CL. 36.

EXPORTADORA PRIZE LIMITADA, REQUINOA, RANCA-  
GUA, CHILE:  
3,941,603, MULTIPLE CLASS, INT. CLS. 31 AND 35.

EXPORTALIZAS MEXICANAS S.A DE C.V., CULIACAN,  
SINALOA, MEXICO:  
3,941,650, INT. CL. 31.

EXPRESS LLC, COLUMBUS, OH:  
2,865,258, CANC. INT. CL. 25.

EXPRESS SOURCE, INC., LOS ANGELES, CA:  
3,940,465, PUB. 1-18-2011, INT. CL. 25.

EXPRESS, LLC, COLUMBUS, OH:  
3,940,740, PUB. 1-18-2011, INT. CL. 25.  
3,940,767, PUB. 1-18-2011, INT. CL. 25.  
3,942,406, INT. CL. 25.

EXTERIOR DESIGN, INC., GLEN ARM, MD:  
2,369,475, CANC. INT. CL. 39.

EXTERIOR DESIGN, INC., GLEN ARM, MD, TA THE  
PERENNIAL FARM:  
3,940,866, PUB. 1-18-2011, INT. CL. 31.  
3,940,867, PUB. 1-18-2011, INT. CL. 31.

EXTRA HANDS SURGICAL SERVICES, LLC, NORMAL, IL,  
DBA YOUR EXTRA HANDS SURGICAL SERVICES:  
3,940,528, PUB. 1-18-2011, INT. CL. 35.

EXTREME NETWORKS, INC., SANTA CLARA, CA:  
2,865,583, CANC. INT. CL. 9.

EXTREME PERFORMANCE, LLC, LOS ALAMITOS, CA,  
AKA EXTREME PERFORMANCE, INC.:  
2,864,739, CANC. INT. CL. 28.

EXTRUDE HONE CORPORATION, IRWIN, PA:  
2,864,140, CANC. MULTIPLE CLASS, INT. CLS. 3, 7 AND  
40.

EXUBERANCE INTERNATIONAL INC., OTTAWA, CANA-  
DA:  
3,939,878, PUB. 1-18-2011, INT. CL. 3.

EZ CPAP, SCOTTSDALE, AZ:  
3,940,759, PUB. 1-18-2011, INT. CL. 35.

EZ PRINTS, INC., ST. CLOUD, FL:  
2,865,338, CANC. MULTIPLE CLASS, INT. CLS. 20 AND  
40.

EZDESK, INC., MURFREESBORO, TN:  
2,490,983, CANC. INT. CL. 36.

E3 ROOFING, LLC, OLATHE, KS:  
3,940,626, PUB. 1-18-2011, INT. CL. 37.

F & C MANAGEMENT LIMITED, LONDON EC2A 2NY,  
ENGLAND:  
2,864,049, CANC. MULTIPLE CLASS, INT. CLS. 9, 16, 35,  
36 AND 38.

F. L. NAVARRO LTD, BROOKLYN, NY, DBA THE ARTI-  
SAN COLLECTION:  
3,941,504, INT. CL. 33.

F.L.NAVARRO LTD, BROOKLYN, NY, DBA THE ARTISAN  
COLLECTION:  
3,941,440, INT. CL. 33.

F.P. WINNER LTD., BALTIMORE, MD:  
3,940,406, PUB. 1-18-2011, INT. CL. 35.  
3,940,407, PUB. 1-18-2011, INT. CL. 35.

FA MANAGEMENT ENTERPRISES, INC., EARTH CITY,  
MO:  
2,367,435, CANC. MULTIPLE CLASS, INT. CLS. 20, 25  
AND 27.

FAB FARM, LLC, HOLLAND, MI, DBA FABRICATION  
FARMERS OF AMERICA:  
3,939,569, PUB. 1-18-2011, MULTIPLE CLASS, INT. CLS.  
6, 16, 20, 21 AND 25.

FABBRICA D'ARMI P. BERETTA, S.P.A., PROVINCE OF  
BRESCIA, ITALY:  
2,434,206, REN. 3-3-11, INT. CL. 13.  
2,435,842, REN. 3-1-11, INT. CL. 13.

FABRICA DE JABON LA CORONA, S.A. DE C.V., XALOS-  
TOC, MEXICO CITY, MEXICO:  
3,940,163, PUB. 1-18-2011, INT. CL. 3.

FAHRENKOPF, PAUL E., WASHINGTON, DC:  
2,865,094, CANC. INT. CL. 42.

FAIRLANE TOOL COMPANY, INC. D/B/A FAIRLANE  
PRODUCTS, INC., FRASER, MI:  
3,940,624, PUB. 1-18-2011, INT. CL. 7.

FAIRMONT HOTELS & RESORTS (U.S.) INC., TORONTO  
ONTARIO M5V0C3, CANADA:  
2,521,541, REN. 3-2-11, INT. CL. 42.

FAIRWINDS PARTNERS, LLC, WASHINGTON, DC:  
3,940,869, PUB. 1-18-2011, MULTIPLE CLASS, INT. CLS.  
35 AND 42.

FALL OUT BOY, INC., WILMETTE, IL:  
3,939,393, PUB. 1-18-2011, INT. CL. 25.

FAMILY AFFAIR COMPANY, GLENDALE, CA:  
2,864,125, CANC. INT. CL. 28.

FAMILY TIME SPORTING APPAREL, LLC, AUSTIN, TX:  
3,941,722, INT. CL. 25.

FAN FI INTERNATIONAL, INC., SPARKS, NV:  
3,941,005, INT. CL. 11.

FANSLER, JENNI, FORSYTH, MO:  
3,940,142, PUB. 1-18-2011, INT. CL. 16.

FANSPEAK, LLC, ARLINGTON, VA:  
3,940,392, PUB. 1-18-2011, INT. CL. 41.

FANTASY SPORTS NOW, INC., BOERNE, TX:  
3,941,940, INT. CL. 41.  
3,941,941, INT. CL. 41.

FANTONI SANDRINE, FRANCE:  
3,939,934, PUB. 1-18-2011, MULTIPLE CLASS, INT. CLS.  
18 AND 25.

FAR EAST IMPORTING AND EXPORTING COMPANY,  
PORTLAND, OR:  
3,941,096, INT. CL. 5.

- FARAH, SHEILA, SAO PAULO, BRAZIL AND PORTO BELLO COM. EXP. PRODUTOS DE HIGIENE LTDA., SAO PAULO, BRAZIL:  
3,942,192, INT. CL. 3.
- FARM COUNTRY TRADER, INC, INWOOD, IA:  
2,865,856, CANC. INT. CL. 35.
- FARMERS FEED MILL, INC., LEXINGTON, KY:  
3,942,253, INT. CL. 31.
- FARREY'S WHOLESALE HARDWARE CO., INC., MIAMI, FL:  
2,425,337, REN. 3-2-11. INT. CL. 35.  
2,425,339, REN. 3-2-11. INT. CL. 35.
- FARRIER PRODUCT DISTRIBUTION, INC, SHELBYVILLE, KY:  
3,939,797, PUB. 1-18-2011. INT. CL. 6.
- FASHION BRANDS HOLDING CORPORATION, CARSON CITY, NV:  
2,431,662, REN. 3-3-11. INT. CL. 25.
- FASHION SHOE LICENSING LLC, NEW HYDE PARK, NY:  
2,864,590, CANC. INT. CL. 25.
- FASTENAL IP COMPANY, WINONA, MN:  
3,940,265, PUB. 1-18-2011. MULTIPLE CLASS, INT. CLS. 9, 21, 25 AND 26.
- FATHERREE, BENJAMIN THOMAS, NEWPORT, KY:  
3,942,228, MULTIPLE CLASS, INT. CLS. 28 AND 35.
- FAVRILLE, INC., SAN DIEGO, CA:  
2,865,468, CANC. INT. CL. 5.
- FAZ RESTAURANT, INC., PLEASANTON, CA:  
3,940,244, PUB. 1-18-2011. INT. CL. 43.
- FBC WORLDWIDE, LLC, HOUSTON, TX:  
3,939,740, PUB. 1-18-2011. INT. CL. 30.
- FC BACKGROUND, LLC, DALLAS, TX, DBA FCB ID:  
3,940,568, PUB. 1-18-2011. INT. CL. 35.
- FCA, LLC, MOLINE, IL:  
3,940,234, PUB. 1-18-2011. MULTIPLE CLASS, INT. CLS. 35, 37, 40 AND 42.
- FEDERAL ALLIANCE OF SAFE HOMES, INC., TALLAHASSEE, FL, AKA FLASH:  
3,940,255, PUB. 1-18-2011. INT. CL. 35.
- FEDERAL HOME LOAN MORTGAGE CORPORATION, MCLEAN, VA:  
2,429,701, REN. 2-26-11. INT. CL. 36.
- FEDERAL-MOGUL WORLD WIDE, INC., SOUTHFIELD, MA:  
711,858, REN. 3-3-11. U.S. CL. 35 (INT. CL. 17).
- FEDERATED AUTO PARTS DISTRIBUTORS, INC., STAUNTON, VA:  
3,939,377, PUB. 1-18-2011. INT. CL. 12.
- FEDERATION OF DEFENSE & CORPORATE COUNSEL, INC., TAMPA, FL:  
3,940,960, PUB. 1-18-2011. INT. CL. 41.
- FEDERATION OF MIGROS COOPERATIVES, ZURICH, SWITZERLAND:  
3,940,314, PUB. 1-18-2011. INT. CL. 3.
- FEDTECHSERVICES, LLC, TAMPA, FL, AKA FTS:  
3,941,749, INT. CL. 38.
- FEEDBREWER INC., BROOMFIELD, CO:  
3,942,258, INT. CL. 42.
- FEINMETALL GESELLSCHAFT MIT BESCHRANKTER HAFTUNG, 71083 HERRENBERG, FED REP GERMANY:  
2,500,618, REN. 2-26-11. INT. CL. 9.
- FEIYUE HOLDING PTE LTD, SINGAPORE:  
3,940,029, PUB. 1-18-2011. MULTIPLE CLASS, INT. CLS. 3, 9, 14, 16, 18, 24, 25, 26, 28 AND 35.
- FELIDIA, INC., NEW YORK, NY:  
2,893,732, CANC. INT. CL. 30.
- FEMININE ENERGETICS INC., GIBSONS, BC, CANADA:  
3,939,647, PUB. 1-18-2011. INT. CL. 21.
- FENDI ADELE S.R.L., ITALY:  
3,940,027, PUB. 1-18-2011. MULTIPLE CLASS, INT. CLS. 18 AND 25.
- FERGUSON ENTERPRISES, INC., NEWPORT NEWS, VA:  
3,941,024, INT. CL. 8.
- FERNANDES GUITARS INTERNATIONAL, INC., NORTH HOLLYWOOD, CA:  
2,368,788, CANC. INT. CL. 15.
- FERNANDEZ, FERNANDO, CAROLINA, PUERTO RICO:  
3,942,412, INT. CL. 45.
- FERNANDEZ, JOSEPH S., SUGAR LAND, TX:  
3,940,728, PUB. 1-18-2011. INT. CL. 11.
- FERRARA PAN CANDY CO., INC., FOREST PARK, IL:  
3,939,824, PUB. 1-18-2011. INT. CL. 33.
- FERREIRA, MAURO R, PALO ALTO, CA, DBA DOUCE FRANCE:  
3,939,615, PUB. 1-18-2011. INT. CL. 30.
- FERRY, DAVID K., NEWINGTON, CT:  
3,940,679, PUB. 1-18-2011. INT. CL. 16.
- FESTFARE, INC, LOS ANGELES, CA:  
3,940,817, PUB. 1-18-2011. INT. CL. 45.
- FGM WORLDWIDE MOVERS & LOGISTICS, INC., MIAMI, FL:  
3,940,354, PUB. 1-18-2011. INT. CL. 39.
- FIBER BOND CORPORATION, MICHIGAN CITY, IN:  
2,435,768, REN. 2-26-11. INT. CL. 11.
- FIBERMARK NORTH AMERICA, INC., BRATTLEBORO, VT:  
3,941,332, INT. CL. 16.
- FIBERTECH NETWORKS, LLC, ROCHESTER, NY:  
2,864,141, CANC. INT. CL. 38.
- FIDELITY SPORTSWEAR COMPANY, EVERETT, MA:  
3,941,638, INT. CL. 25.
- FIDESSA GROUP, PLC, WOKING, SURREY, UNITED KINGDOM:  
3,942,294, MULTIPLE CLASS, INT. CLS. 9 AND 42.
- FIELD & STREAM LICENSES COMPANY, LLC, WESTPORT, CT:  
2,864,725, CANC. INT. CL. 33.
- FIESTA MEXICANA RESTAURANTS, CHICAGO, IL:  
3,939,434, PUB. 1-18-2011. INT. CL. 43.
- FIFTH THIRD PROCESSING SOLUTIONS, LLC, CINCINNATI, OH:  
3,939,459, PUB. 1-18-2011. INT. CL. 36.
- FIFTY EGGS INC., WELLESLEY HILLS, MA AND FIFTY EGGS LLC, WELLESLEY HILLS, MA:  
2,466,805, REN. 2-26-11. INT. CL. 25.
- FIGARO'S ITALIAN PIZZA, INC., SALEM, OR:  
2,865,284, CANC. INT. CL. 35.
- FIGUEROA MOUNTAIN BREWING, LLC, VENTURA, CA:  
3,941,000, INT. CL. 32.
- FILTHY BRANDS, LLC, BOCA RATON, FL:  
3,940,529, PUB. 1-18-2011. MULTIPLE CLASS, INT. CLS. 29 AND 35.  
3,940,770, PUB. 1-18-2011. INT. CL. 29.
- FINANCE AUTHORITY OF MAINE, AUGUSTA, ME:  
2,472,193, REN. 2-28-11. INT. CL. 36.  
2,476,425, REN. 2-28-11. INT. CL. 36.  
2,476,434, REN. 2-28-11. INT. CL. 36.
- FINE PAINTS OF EUROPE, INC., WOODSTOCK, VT:  
2,501,590, REN. 3-3-11. INT. CL. 17.
- FINESTONE PARTNERS, BEVERLY HILLS, CA:  
3,939,657, PUB. 1-18-2011. INT. CL. 36.
- FINMECCANICA SOCIETA' PER AZIONI, ROMA, ITALY:  
3,939,888, PUB. 1-18-2011. MULTIPLE CLASS, INT. CLS. 7, 9, 11 AND 12.
- FIREBOY-XINTEX, INC., GRAND RAPIDS, MI:  
3,939,761, PUB. 1-18-2011. INT. CL. 9.
- FIRESTONE BUILDING PRODUCTS COMPANY, LLC, INDIANAPOLIS, IN:  
2,369,336, CANC. INT. CL. 19.
- FIRST AID PROFILE, INC., BRISTOL, RI:  
2,369,537, CANC. INT. CL. 14.
- FIRST ALERT TRUST, THE, ST. PAUL, MN:  
2,427,078, REN. 2-25-11. INT. CL. 9.
- FIRST EIE SA, 1227 LES ACACIAS, SWITZERLAND:  
2,427,815, REN. 2-25-11. MULTIPLE CLASS, INT. CLS. 9, 37 AND 42.
- FIRST INTERNATIONAL DIGITAL, INC., SCHAUMBURG, IL:  
2,865,751, CANC. INT. CL. 9.
- FIRST MAGNUS FINANCIAL CORPORATION, TUCSON, AZ:  
2,864,229, CANC. INT. CL. 36.
- FIRST PRINCIPLES, INC., ALBANY, NY:  
3,942,064, INT. CL. 41.
- FIRSTMERIT CORPORATION, AKRON, OH:  
3,941,700, INT. CL. 36.

FISCHER DESIGN GROUP, LLC, PEORIA, AZ:  
3,940,737, PUB. 1-18-2011. INT. CL. 42.

FISCHER, LAURIE KAY, JACKSONVILLE, FL:  
2,865,578, CANC. INT. CL. 22.

FISERV, INC., BROOKFIELD, WI:  
3,940,627, PUB. 1-18-2011. INT. CL. 45.  
3,940,628, PUB. 1-18-2011. INT. CL. 45.

FISKARS CORPORATION, HELSINKI, FINLAND:  
3,941,189, INT. CL. 8.

FISOC, INC., AUSTIN, TX:  
3,941,944, MULTIPLE CLASS, INT. CLS. 35 AND 42.

FIT LIFE, PLANO, TX:  
2,864,328, CANC. INT. CL. 36.

FITNESS CHOICE, L.L.C., BATON ROUGE, LA:  
2,864,632, CANC. INT. CL. 44.  
2,864,663, CANC. INT. CL. 29.

FITNESS INNOVATIONS INCORPORATED, PITTSBURGH, PA:  
2,431,133, REN. 2-26-11. MULTIPLE CLASS, INT. CLS. 41 AND 42.

FITNESS QUEST, INC., CANTON, OH:  
3,942,051, INT. CL. 35.

FIVE FOOT THICK, LLP, SPOKANE, WA:  
2,865,718, CANC. INT. CL. 41.

FIVE STAR HOLIDAY DECOR INC., SPRINGVILLE, UT:  
3,940,891, PUB. 1-18-2011. INT. CL. 37.

FÉDÉRATION INTERNATIONALE DE FOOTBALL ASSOCIATION (FIFA), CH-8044 ZÜRICH, SWITZERLAND:  
3,821,941, CANC. INT. CL. 30.

FL FOOD LION, INC., SALISBURY, NC:  
3,941,835, INT. CL. 5.

FLAHERTY, THOMAS J, BORDENTOWN, NJ:  
2,865,368, CANC. INT. CL. 41.

FLANDERS CORPORATION, WASHINGTON, NC:  
1,165,405, REN. 3-3-11. INT. CL. 11.

FLASHEALTH, LLC, NASHUA, NH:  
3,940,370, PUB. 1-18-2011. INT. CL. 9.

FLATIRONS SOLUTIONS CORPORATION, BOULDER, CO:  
3,942,405, INT. CL. 9.

FLEER/SKYBOX INTERNATIONAL LP, MT. LAUREL, NJ TO FSB ACQUISITION COMPANY, LLC, NORTH LAS VEGAS, NV:  
2,369,354, CANC. INT. CL. 16.

FLEER/SKYBOX INTERNATIONAL LP, MT LAUREL, NJ TO FSB ACQUISITION COMPANY, LLC, NORTH LAS VEGAS, NV:  
2,369,359, CANC. INT. CL. 16.

FLEET WHOLESAL SUPPLY CO., INC., APPLETON, WI:  
3,940,388, PUB. 1-18-2011. INT. CL. 28.

FLEX-HINGE VALVE COMPANY, ERIE, PA, FLEX-HINGE VALVE COMPANY, ERIE, PA:  
2,495,671, REN. 3-2-11. INT. CL. 9.

FLEXERA SOFTWARE, INC., SCHAUMBURG, IL:  
3,939,561, PUB. 1-18-2011. MULTIPLE CLASS, INT. CLS. 9 AND 42.

FLICKERING SCENTS, LLC, MELBA, ID:  
3,940,892, PUB. 1-18-2011. INT. CL. 4.

FLIP DOG POWER YOGA AND PILATES, LLC, LAHASKA, PA:  
2,865,287, CANC. INT. CL. 41.

FLIR SYSTEMS, INC., WILSONVILLE, OR:  
2,865,574, CANC. INT. CL. 9.

FLOMO PLASTICS INDUSTRIAL CO., LTD., TAINAN, TAIWAN:  
1,673,552, REN. 2-26-11. INT. CL. 28.

FLORIDA PANTHERS HOCKEY CLUB, LTD., SUNRISE, FL:  
3,941,773, INT. CL. 25.  
3,941,774, INT. CL. 41.

FLORIDA SILICA SAND COMPANY, FT. LAUDERDALE, FL:  
2,458,815, REN. 3-1-11. INT. CL. 11.

FLORIDA UNITED METHODIST CHILDREN'S HOME, INC., ENTERPRISE, FL:  
3,940,861, PUB. 1-18-2011. MULTIPLE CLASS, INT. CLS. 41 AND 45.

FLOWDECOR INC., TORONTO, ON, CANADA:  
3,939,830, PUB. 1-18-2011. MULTIPLE CLASS, INT. CLS. 11 AND 20.

FLOWER POT PRODUCTIONS, LLC, PASADENA, CA:  
3,942,056, MULTIPLE CLASS, INT. CLS. 35 AND 41.

FLYERWHIZ, LLC, ROCKLIN, CA:  
3,941,637, INT. CL. 16.

FLYING DOG BREWERY L.L.C., DENVER, CO:  
2,809,721, CANC. INT. CL. 40.

FOAMEX INNOVATIONS OPERATING COMPANY, MEDIA, PA:  
3,940,952, PUB. 1-18-2011. INT. CL. 17.

FOCUS ONE PROMOTIONS, INC., ASTON, PA:  
2,368,908, CANC. INT. CL. 35.

FOCUSED HEALTH SOLUTIONS, INC., NORTHBROOK, IL:  
2,864,553, CANC. INT. CL. 44.

FOGARTY HOLDINGS LIMITED, LINCOLNSHIRE, UNITED KINGDOM:  
2,865,825, CANC. MULTIPLE CLASS, INT. CLS. 20 AND 24.

FOLLOWILL MUSIC, INC., NASHVILLE, TN:  
3,940,594, PUB. 1-18-2011. INT. CL. 41.  
3,940,596, PUB. 1-18-2011. INT. CL. 25.

FONT BUREAU, INC., THE, BOSTON, MA:  
2,445,625, REN. 2-26-11. INT. CL. 9.

FORBO FINANCIAL SERVICES AG, BAAR, SWITZERLAND:  
1,154,045, REN. 2-28-11. INT. CL. 27.

FOREFIELD, INC., MALBORO, MA:  
2,369,314, CANC. INT. CL. 9.

FOREMAN JR. HERBERT M., RAYMOND, MS, DBA ADVANTAGE SEED COMPANY:  
3,941,887, INT. CL. 31.

FOREMOST CORPORATION OF AMERICA, CALEDONIA, MI:  
2,864,539, CANC. INT. CL. 41.

FORESMAN, GUY STUART, SANTA ANA, CA:  
3,942,328, INT. CL. 41.

FORISK CONSULTING, LLC, ATHENS, GA:  
3,940,161, PUB. 1-18-2011. MULTIPLE CLASS, INT. CLS. 35, 36 AND 42.

FORMAN, FRANK, FORT LAUDERDALE, FL:  
3,942,459, INT. CL. 37.

FORMAT TRESORBAN GMBH & CO. KG, HESSISCH LICHTENAU, FED REP GERMANY:  
3,939,515, PUB. 1-18-2011. MULTIPLE CLASS, INT. CLS. 6 AND 9.

FORMCRETE FIBERGLASS PRODUCTS, INC., SEMINOLE, OK:  
2,481,225, REN. 3-2-11. INT. CL. 19.

FORMWAY FURNITURE LIMITED, SEAVIEW, WELLINGTON, NEW ZEALAND:  
2,864,690, CANC. INT. CL. 20.

FORRESTER LABORATORIES, CHICAGO, IL:  
2,430,659, REN. 2-26-11. INT. CL. 3.

FORRESTER MANUFACTURING COMPANY, INC., BUFORD, GA:  
3,939,803, PUB. 1-18-2011. INT. CL. 8.

FORSYTHE COSMETIC GROUP, LTD., LAWRENCE, NY:  
3,939,799, PUB. 1-18-2011. INT. CL. 3.  
3,940,102, PUB. 1-18-2011. INT. CL. 3.

FORTUNE DYNAMIC INC., CITY OF INDUSTRY, CA:  
3,940,464, PUB. 1-18-2011. INT. CL. 25.

FOSHAN GONSIN; DIGITAL CONFERENCE EQUIPMENT CO., LTD., CHINA:  
3,939,948, PUB. 1-18-2011. INT. CL. 9.

FOSTER, SCOTT, VANCOUVER, BC, CANADA:  
3,940,668, PUB. 1-18-2011. INT. CL. 41.

FOUNDATION FOR EXCELLENCE IN HEALTHCARE, INC., NORTHAMPTON, MA:  
2,431,953, REN. 2-26-11. INT. CL. 41.

FOUNDATION TECHNOLOGIES, INC., GREENVILLE, SC:  
2,865,285, CANC. MULTIPLE CLASS, INT. CLS. 37 AND 42.

FOUNTAIN ANTI-AGING LLC, WESTLAKE, OH:  
3,940,333, PUB. 1-18-2011. INT. CL. 44.

FOUR S GROUP, INC., CORAL GABLES, FL:  
2,639,169, CANC. INT. CL. 9.

- FOUR STAR DRIVE-IN RESTAURANTS, L.P., EDMOND, OK:  
3,939,456, PUB. 1-18-2011. INT. CL. 43.
- FOUR TINES LLC, EAST QUOGUE, NY, FORMERLY RED TRACTOR FOODS LLC:  
3,941,640, INT. CL. 29.  
3,941,641, INT. CL. 29.  
3,941,642, INT. CL. 29.
- FOURSIGHT GAME SYSTEMS, LLC, STAMFORD, CT:  
3,942,141, INT. CL. 9.
- FOWLER, VANESSA N., HONOLULU, HI AND FOWLER, MAX R., HONOLULU, HI:  
3,942,097, INT. CL. 25.
- FOX FACTORY, INC., WATSONVILLE, CA:  
3,940,275, PUB. 10-12-2010. INT. CL. 12.
- FOX 40 INTERNATIONAL INC, STONEY CREEK, CANADA:  
3,941,932, INT. CL. 28.
- FOX, MARA, TOLUCA LAKE, CA:  
2,864,698, CANC. INT. CL. 28.
- FRAKES, R ERIC, VACAVILLE, CA:  
3,177,601, CANC. INT. CL. 43.
- FRANCE PUBLICATIONS, INC., ATLANTA, GA:  
3,940,311, PUB. 1-18-2011. INT. CL. 16.
- FRANCHISE SPORTS MARKETING, LLC, DALLAS, TX:  
3,939,581, PUB. 1-18-2011. INT. CL. 16.
- FRANK BRUNCKHORST CO., L.L.C., BROOKLYN, NY:  
3,940,919, PUB. 1-18-2011. INT. CL. 29.
- FRANK J. SEPE, INC., VALLEY STREAM, NY:  
3,942,011, MULTIPLE CLASS, INT. CLS. 9, 16 AND 28.
- FRANK, LARRY D., OVIEDO, FL:  
3,939,348, PUB. 10-12-2010. INT. CL. 16.
- FRANK'S CASING CREW & RENTAL TOOLS, INC., LA-FAYETTE, LA:  
2,491,723. REN. 3-2-11. MULTIPLE CLASS, INT. CLS. 6, 17, 35 AND 37.
- FRANKEL DESIGN INC., WOODLAND HILLS, CA:  
3,942,022, INT. CL. 25.
- FRANKEL, HEYWOOD, NEW YORK, NY:  
2,864,401, CANC. INT. CL. 25.
- FRANKEL, JORDAN D., ATLANTA, GA:  
2,474,738. REN. 2-26-11. INT. CL. 17.
- FRANKFORD FOODS, INC., PHILADELPHIA, PA:  
3,500,325, CANC. INT. CL. 29.
- FRANKLIN COUNTY HISTORICAL SOCIETY, COLUMBUS, OH:  
3,941,025, INT. CL. 25.
- FRANKLIN COVEY PRODUCTS, LLC., SALT LAKE CITY, UT:  
2,368,479, CANC. INT. CL. 16.
- FRANKLIN PAINT COMPANY, INC., FRANKLIN, MA:  
1,636,598. REN. 2-26-11. INT. CL. 2.
- FRASER MACHINERY LTD., SURREY, BRITISH COLUMBIA, CANADA:  
2,367,433, CANC. INT. CL. 37.
- FRED BERGMAN HEALTHCARE PTY LTD, MELBOURNE VIC 3004, AUSTRALIA:  
3,939,907, PUB. 1-18-2011. MULTIPLE CLASS, INT. CLS. 5, 9 AND 10.
- FRED J. KIM DDS, INC., REDONDO BEACH, CA:  
3,940,722, PUB. 1-18-2011. INT. CL. 44.
- FRED MARTIN MOTOR COMPANY, BARBERTON, OH:  
3,939,392, PUB. 1-18-2011. INT. CL. 36.
- FRED MEYER STORES, INC, PORTLAND, OR:  
3,940,344, PUB. 1-18-2011. INT. CL. 30.
- FRED MEYER STORES, INC., PORTLAND, OR:  
2,973,887, CANC. MULTIPLE CLASS, INT. CLS. 6, 9, 11, 14 AND 19.
- FREE RADT, DENVER, CO:  
3,941,038, INT. CL. 41.
- FREEDOM GROUP, INC., RENO, NV:  
3,941,158, INT. CL. 35.
- FREEDOM SERVICES, INC., BALTIMORE, MD:  
3,940,365, PUB. 1-18-2011. INT. CL. 39.
- FREEDOM STONES INTERNATIONAL, FRISCO, TX:  
3,939,367, PUB. 1-18-2011. INT. CL. 14.
- FREELIFE INTERNATIONAL HOLDINGS, LLC, PHOENIX, AZ:  
2,367,671, CANC. INT. CL. 5.
- FREHLING ENTERPRISES, INC., MIAMI, FL, DBA OGGETTI:  
3,047,163, CANC. MULTIPLE CLASS, INT. CLS. 14, 16 AND 28.
- FREUDENBERG NONWOVENS LIMITED PARTNERSHIP, LOWELL, MA:  
2,864,101, CANC. INT. CL. 7.
- FRIEDA & NELLIE INC., GARDEN CITY, NY:  
3,940,335, PUB. 1-18-2011. INT. CL. 14.
- FRIEDLANDER, GARY, S, BUFFALO GROVE, IL:  
2,520,300. REN. 3-3-11. INT. CL. 42.
- FRIEDMAN, LORRAINE, ALEXANDRIA, VA:  
2,375,827. REN. 3-1-11. INT. CL. 16.
- FRIENDS OF MAINE'S SEABIRD ISLANDS, ROCKPORT, ME:  
3,940,136, PUB. 1-18-2011. INT. CL. 35.  
3,940,138, PUB. 1-18-2011. INT. CL. 35.
- FRITO-LAY NORTH AMERICA, INC., PLANO, TX:  
3,941,217, INT. CL. 29.  
3,942,132, INT. CL. 30.
- FROG 623 LLC, MERCHANTVILLE, NJ:  
3,942,036, INT. CL. 30.
- FROGMAN CHARTERS INC., LAHAINA, HI:  
3,939,406, PUB. 4-29-2008. MULTIPLE CLASS, INT. CLS. 9, 28 AND 41.
- FROM SOCIETÀ AGRICOLA COOPERATIVA, ITALY:  
3,939,957, PUB. 1-18-2011. MULTIPLE CLASS, INT. CLS. 29, 30, 31, 32 AND 33.
- FRONT PORCH CLASSICS, INC., SEATTLE, WA:  
2,864,683, CANC. INT. CL. 28.
- FRONT RANGE SNACKS, INC., CENTENNIAL, CO:  
3,940,833, PUB. 1-18-2011. INT. CL. 30.
- FRONTLINE LENDING CORPORATION, HUNTINGTON BEACH, CA:  
2,865,052, CANC. INT. CL. 36.
- FROZEN GURU LLC, ROSLYN, NY:  
3,939,366, PUB. 1-18-2011. INT. CL. 30.
- FRYMASTER LLC, SHREVEPORT, LA:  
2,368,080, CANC. INT. CL. 11.  
2,368,081, CANC. INT. CL. 9.  
2,368,082, CANC. INT. CL. 9.  
2,368,083, CANC. INT. CL. 11.
- FRYSHMAN, BERNARD, BROOKLYN, NY:  
2,491,465. REN. 3-1-11. INT. CL. 16.
- FSM FASHION SPORT MARKETING INC., VANCOUVER, BRITISH COLUMBIA, CANADA:  
1,607,062, CANC. MULTIPLE CLASS, INT. CLS. 3 AND 42.
- FS4USA, MIDLAND, MI:  
3,940,807, PUB. 1-18-2011. INT. CL. 42.
- FTEN, INC., NEW YORK, NY:  
3,941,444, INT. CL. 9.
- FTI CONSULTING, INC., ANNAPOLIS, MD:  
3,941,049, MULTIPLE CLASS, INT. CLS. 35, 36, 42 AND 45.
- FTI FLOW TECHNOLOGY, INC., TEMPE, AZ:  
2,529,730. REN. 3-2-11. INT. CL. 9.
- FU, CHRISTOPHER, MONTEREY PARK, CA AND ALMO, STEVEN, ROWLAND HEIGHTS, CA:  
2,865,131, CANC. INT. CL. 28.
- FUDGE, JAMES C, COLQUITT, GA:  
2,865,722, CANC. INT. CL. 31.
- FUEL TECH, INC., WARRENVILLE, IL:  
2,920,129, CANC. MULTIPLE CLASS, INT. CLS. 9 AND 16.
- FUELLE, RANDY, EL CAJON, CA:  
2,666,044, CANC. INT. CL. 9.
- FUJIAN VEGSALON CATERING CO., LTD., ZHANGZHOU, FUJIAN, CHINA:  
3,941,353, INT. CL. 43.
- FUJIREBIO INC., TOKYO, JAPAN:  
3,940,286, PUB. 1-18-2011. MULTIPLE CLASS, INT. CLS. 5 AND 10.
- FUN PRODUCTS LLC, WOODS CROSS, UT:  
3,940,789, PUB. 1-18-2011. INT. CL. 28.



FUNDEX GAMES, LTD., INDIANAPOLIS, IN:  
2,369,443, CANC. INT. CL. 28.

FUNKE WÄRMEAUSTAUSCHER; APPARATEBAU GMBH,  
FED REP GERMANY:  
3,939,949, PUB. 1-18-2011. MULTIPLE CLASS, INT. CLS. 7  
AND 11.

FURUKAWA DENKI KOGYO KABUSHIKI KAISHA, TO-  
KYO, JAPAN, DBA THE FURUKAWA ELECTRIC CO.,  
LTD.:  
3,939,390, PUB. 1-18-2011. MULTIPLE CLASS, INT. CLS.  
6, 9, 12 AND 17.

FUSELIER, DONALD, LAFAYETTE, LA:  
2,865,815, CANC. INT. CL. 12.

FUTURE SALES CORPORATION, MARKHAM, ONTARIO,  
CANADA:  
2,367,991, CANC. INT. CL. 6.

FUTURETECH CONSULTING, INC., WEST CONSHO-  
HOCKEN, PA:  
2,368,483, CANC. MULTIPLE CLASS, INT. CLS. 35 AND  
41.

FUZHOU BOLING PHOTOGRAPHIC; EQUIPMENT CO.,  
LTD., CHINA:  
3,940,004, PUB. 1-18-2011. INT. CL. 9.

FUZION FOOD GROUP USA, INC., SIOUX FALLS, SD:  
2,506,090, REN. 3-1-11. INT. CL. 42.

G.S. BLODGETT COMPANY, INC., BURLINGTON, VT TO  
G.S. BLODGETT CORPORATION, BURLINGTON, VT:  
1,426,480, CANC. INT. CL. 11.

GABRIELLE STUDIO, INC, NEW YORK, NY, KARAN,  
DONNA, NEW YORK, NY:  
1,646,910, REN. 3-2-11. INT. CL. 25.

GABRIELLE STUDIO, INC., NEW YORK, NY:  
2,470,110, REN. 2-26-11. INT. CL. 25.

GAINES GROUP LLC, HOUSTON, TX:  
3,939,562, PUB. 3-30-2010. MULTIPLE CLASS, INT. CLS.  
4, 11 AND 21.

GALATI, DANIEL, CHESTERFIELD, MO:  
3,941,310, INT. CL. 12.

GALE GROUP, INC., THE, FARMINGTON HILLS, MI:  
2,368,175, CANC. MULTIPLE CLASS, INT. CLS. 9, 35  
AND 42.

GALEN HOOVER, MT. HOPE, OH:  
3,940,766, PUB. 1-18-2011. INT. CL. 35.

GALLAGHER, RICHARD N., PHOENIX, AZ:  
2,864,228, CANC. MULTIPLE CLASS, INT. CLS. 18, 25  
AND 34.

GALT, LLC, WARREN, PA:  
3,942,410, INT. CL. 18.

GALUMBECK PLASTIC SURGERY, VIRGINIA BEACH, VA:  
2,865,655, CANC. INT. CL. 3.

GAMBALE, CHRISTINA, NEW YORK, NY, DBA GREEN-  
WICH JEWELERS AND GANDIA, JENNIFER, NEW  
YORK, NY, DBA GREENWICH JEWELERS:  
3,940,111, PUB. 1-18-2011. INT. CL. 14.

GAME ONE, PARIS, FRANCE:  
2,863,917, CANC. MULTIPLE CLASS, INT. CLS. 38 AND  
42.

GAMEZEBO, INC., SAN FRANCISCO, CA:  
3,941,881, INT. CL. 41.

GAONA, DANIEL, PADILLA, GUADALAJARA, MEXICO:  
2,865,032, CANC. INT. CL. 25.

GAP (APPAREL), LLC, SAN FRANCISCO, CA:  
2,512,889, REN. 3-2-11. INT. CL. 35.  
3,942,137, INT. CL. 35.

GARAGE DOCTORS, INC., LUTZ, FL:  
2,864,003, CANC. MULTIPLE CLASS, INT. CLS. 2, 19, 37  
AND 42.

GARDNER LANDRY COMMUNICATIONS LP, HOUSTON,  
TX:  
3,942,174, INT. CL. 25.  
3,942,175, INT. CL. 25.

GARLAND COMMERCIAL INDUSTRIES LLC, FREE-  
LAND, PA:  
2,429,293, REN. 2-26-11. INT. CL. 11.

GARMIN SWITZERLAND GMBH, SCHAFFHAUSEN, SWIT-  
ZERLAND:  
3,941,771, MULTIPLE CLASS, INT. CLS. 9, 38, 39 AND 42.

GARY SHURLEY, SACRAMENTO, CA:  
3,941,827, INT. CL. 41.

GASPARI NUTRITION, INC., LAKEWOOD, NJ:  
3,942,208, INT. CL. 5.  
3,942,209, INT. CL. 5.

GATEWAY GLOBAL LTD., KOWLOON, HONG KONG:  
2,436,740, REN. 2-26-11. INT. CL. 28.

GATEWAY, INC., IRVINE, CA:  
2,367,392, CANC. INT. CL. 35.

GATHER, INC., BOSTON, MA:  
3,942,444, INT. CL. 42.

GAYLA INDUSTRIES, INC., HOUSTON, TX:  
1,147,271, REN. 3-2-11. INT. CL. 28.

GB ACQUISTION, INC., CHATTANOOGA, TN:  
2,461,160, REN. 2-26-11. INT. CL. 42.

GB ACQUISTION, INC., CHATTANOOGA, TN TO GB  
ACQUISTION, INC., CHATTANOOGA, TN:  
2,606,394, CANC. INT. CL. 42.

GE HEALTHCARE LIMITED, BUCKINGHAMSHIRE, UNI-  
TED KINGDOM:  
2,864,844, CANC. MULTIPLE CLASS, INT. CLS. 1, 5, 9, 10,  
41, 42 AND 44.

GE HEALTHCARE LIMITED UK, BUCKINGHAMSHIRE,  
UNITED KINGDOM:  
2,369,235, CANC. MULTIPLE CLASS, INT. CLS. 1, 9 AND  
42.

GEARHART UNITED PTY LTD., SOUTH AUSTRALIA,  
5013, AUSTRALIA:  
2,380,526, REN. 2-26-11. INT. CL. 7.

GEARY, SUSAN, SALEM, VA:  
3,939,823, PUB. 1-18-2011. INT. CL. 35.

GEBBIA, JIM, MATTITUCK, NY:  
3,941,615, INT. CL. 35.

GENERAL CIGAR CO., INC., GLEN ALLEN, VA, CI-  
FUENTES Y COMPANIA, HABANA, CUBA:  
529,452, REN. 2-28-11. U.S. CL. 17 (INT. CL. 34).

GENERAL ELECTRIC COMPANY, SCHENECTADY, NY:  
2,369,367, CANC. INT. CL. 11.  
2,429,420, REN. 3-3-11. INT. CL. 9.  
3,942,135, INT. CL. 7.

GENERAL MAGNAPLATE CORPORATION, LINDEN, NJ:  
727,342, REN. 3-3-11. U.S. CL. 106 (INT. CL. 40).

GENERAL MEDIA COMMUNICATIONS, INC., BOCA RA-  
TON, FL:  
2,744,275, CANC. INT. CL. 34.

GENERAL MILLS IP HOLDINGS II, LLC, MINNEAPOLIS,  
MN:  
1,648,275, REN. 3-1-11. INT. CL. 30.

GENERAL NUTRITION INVESTMENT COMPANY, PHOE-  
NIX, AZ AND RITE AID CORPORATION, CAMP HILL,  
PA:  
2,518,097, REN. 3-2-11. INT. CL. 5.

GENERAL NUTRITION INVESTMENT COMPANY, PHOE-  
NIX, AZ:  
3,941,916, INT. CL. 5.

GENERAL PHYSIOTHERAPY, INC., EARTH CITY, MO:  
1,668,397, REN. 3-2-11. INT. CL. 10.

GENEROUS GIVING, INC., CHATTANOOGA, TN:  
2,431,537, REN. 3-1-11. INT. CL. 41.

GENESEE VALLEY MOTORS, INC., AVON, NY:  
3,942,394, MULTIPLE CLASS, INT. CLS. 35 AND 37.

GENIUS KIDS DEVELOPMENT, INC., FREMONT, CA:  
3,940,304, PUB. 1-18-2011. INT. CL. 35.

GENSO LLC, ROSELLE, NJ:  
3,942,453, INT. CL. 5.

GENUINE HEALTH INC., TORONTO, CANADA:  
3,940,106, PUB. 1-18-2011. INT. CL. 5.

GEOCOMFORT, INC, GREENVILLE, IL:  
3,940,536, PUB. 1-18-2011. INT. CL. 11.

GEOGRAPHIC SOLUTIONS, INC., PALM HARBOR, FL:  
3,942,435, INT. CL. 35.

GEOGREEN BIOFUELS, INC., VERNON, CA:  
3,880,173, COR. INT. CL. 40.

GEOMETRICS, INC., SAN JOSE, CA:  
2,447,787, REN. 3-3-11. INT. CL. 9.

GEONOVA HOLDINGS, LTD. LLC, NEW YORK, NY:  
3,940,585, PUB. 1-18-2011. INT. CL. 40.  
3,940,587, PUB. 1-18-2011. INT. CL. 36.

- GEORGE P. JOHNSON COMPANY, INC., AUBURN HILLS, MI:  
2,865,337, CANC. MULTIPLE CLASS, INT. CLS. 41 AND 42.
- GEORGE, MANSOUR J., LOSANGELES, CA:  
3,942,232, INT. CL. 10.
- GEORGE, SARAH B., PITTSBURGH, PA:  
2,864,504, CANC. INT. CL. 41.
- GEORGIA BOOT LLC, FRANKLIN, TN TO ROCKY BRANDS WHOLESALE LLC, NELSONVILLE, OH:  
2,421,992, CANC. INT. CL. 25.
- GEORGIA ENVIRONMENTAL TECHNOLOGIES, LLC, ALPHARETTA, GA:  
3,940,401, PUB. 1-18-2011. INT. CL. 17.
- GEORGIA TECH RESEARCH CORPORATION, GEORGIA TECH, ATLANTA, GA:  
2,864,269, CANC. INT. CL. 9.
- GEORGIA-PACIFIC CONSUMER PRODUCTS LP, ATLANTA, GA:  
2,541,578, REN. 2-26-11. INT. CL. 16.
- GEORGIE BEAUTY, LLC, THOMASVILLE, GA:  
3,939,674, PUB. 1-18-2011. INT. CL. 3.
- GEORGOPOULOS, JOHN T., GLEN OAKS, NY:  
2,368,673, CANC. INT. CL. 42.
- GEOSERVICES EQUIPEMENTS, ROISSY EN FRANCE, FRANCE:  
3,940,425, PUB. 1-18-2011. MULTIPLE CLASS, INT. CLS. 9 AND 37.
- GEOSPATIAL INFORMATION & TECHNOLOGY ASSOCIATION, AURORA, CO TO GEOSPATIAL INFORMATION & TECHNOLOGY ASSOCIATION, AURORA, CO:  
2,367,411, CANC. MULTIPLE CLASS, INT. CLS. 41 AND 42.
- GEOX S.P.A., MONTEBELLUNA FRAZIONE BIADENE (TREVISO), ITALY:  
2,864,110, CANC. INT. CL. 25.
- GERLI & CO., INC., PLAINS, PA:  
2,634,341, CANC. INT. CL. 24.
- GETAUTOBIDS, INC., NEW YORK, NY:  
3,942,119, MULTIPLE CLASS, INT. CLS. 35 AND 38.
- GFSI, INC., LENEXA, KS:  
1,674,293, REN. 3-1-11. INT. CL. 25.
- GHENT MANUFACTURING, INC., LEBANON, OH:  
2,431,619, REN. 2-26-11. INT. CL. 16.
- GIANT SCREEN CINEMA ASSOCIATION, INC., BUMPASS, VA:  
3,939,738, PUB. 1-18-2011. U.S. CL. B.
- GIBNEY, JOEL, SANTA BARBARA, CA:  
2,864,499, CANC. INT. CL. 10.
- GIBSON RESEARCH CORPORATION, IRVINE, CA:  
2,438,312, REN. 2-26-11. INT. CL. 42.
- GIL MANUFACTURING, INC., MONTGOMERY, AL:  
3,939,381, PUB. 1-18-2011. INT. CL. 5.
- GILBERT, JANELLE, CHICAGO, IL:  
3,941,199, MULTIPLE CLASS, INT. CLS. 9 AND 41.
- GILDAN ACTIVEWEAR INC. / LES VETEMENTS DE SPORT GILDAN INC., ST - LAURENT, CANADA:  
3,356,083, CANC. INT. CL. 25.
- GILLESPIE, HELEN D., SANTA ROSA, CA:  
2,552,817, CANC. INT. CL. 42.
- GILMORE, KENNETH L., CHATSWORTH, CA AND GILMORE, JOHN A., CHATSWORTH, CA:  
2,864,095, CANC. INT. CL. 20.
- GIMME SUM GEAR, LLC, HENDERSON, NV:  
2,864,826, CANC. INT. CL. 25.
- GIORGIO COSANI, INC., COMMERCE, CA:  
3,940,694, PUB. 1-18-2011. INT. CL. 25.
- GIRLFRIEND U, LLC, SCOTTSDALE, AZ:  
3,941,756, INT. CL. 41.  
3,941,757, INT. CL. 41.
- GIRLS WRITE NOW, INC., NEW YORK, NY:  
3,941,116, MULTIPLE CLASS, INT. CLS. 16 AND 41.  
3,941,117, MULTIPLE CLASS, INT. CLS. 16 AND 41.
- GIVELOCALLY LLC, LOS ALTOS, CA:  
3,940,468, PUB. 1-18-2011. INT. CL. 36.  
3,940,470, PUB. 1-18-2011. INT. CL. 36.
- GIVENS, RUSSELLY, DALLAS, TX:  
3,939,698, PUB. 1-18-2011. MULTIPLE CLASS, INT. CLS. 9 AND 41.
- GKN HOLDINGS PLC, REDDITCH, WORCESTERSHIRE, UNITED KINGDOM:  
1,610,370, REN. 2-25-11. MULTIPLE CLASS, INT. CLS. 6, 7, 12 AND 17.
- GL INTERNATIONAL, LLC, YOUNGSTOWN, OH, CANTAR INC., REXDALE, ONTARIO, CANADA:  
1,635,495, REN. 2-28-11. INT. CL. 19.
- GL SUITE, INC., BEND, OR:  
3,941,547, INT. CL. 42.  
3,941,548, INT. CL. 9.
- GLADNEY, LESLIE HAYS, BATON ROUGE, LA AND BUCKINGHAM, BEVERLY GLADNEY, BATON ROUGE, LA:  
2,367,518, CANC. INT. CL. 42.
- GLADSTONE'S UNDER THE SUN, BAR HARBOR, ME:  
2,865,854, CANC. INT. CL. 29.
- GLAXO GROUP LIMITED, GREENFORD, MIDDLESEX, UNITED KINGDOM:  
2,864,991, CANC. INT. CL. 5.
- GLAXOSMITHKLINE LLC, WILMINGTON, DE:  
2,449,822, REN. 3-3-11. INT. CL. 16.  
2,468,396, REN. 2-26-11. MULTIPLE CLASS, INT. CLS. 16 AND 42.
- GLAZIER, STEPHEN C., WASHINGTON, DC:  
2,382,147, REN. 3-2-11. INT. CL. 16.
- GLC LIMITED, GIBRALTAR:  
2,407,463, CANC. MULTIPLE CLASS, INT. CLS. 9, 25, 28, 35, 36 AND 41.
- GLENN, EDWARD C., GREENVILLE, NC:  
2,864,527, CANC. INT. CL. 26.
- GLENWOOD SPRINGS CHAMBER RESORT ASSOCIATION, INC., GLENWOOD SPRINGS, CO:  
3,940,446, PUB. 1-18-2011. INT. CL. 35.
- GLOBAL ASSOCIATION OF RISK PROFESSIONAL S, INC., JERSEY CITY, NJ:  
2,875,003, COR. INT. CL. 35.
- GLOBAL BEVERAGE MARKETING CORPORATION, HAMILTON, BERMUDA:  
2,863,933, CANC. MULTIPLE CLASS, INT. CLS. 14 AND 25.
- GLOBAL COMPUTER SUPPLIES INC., PORT WASHINGTON, NY:  
2,416,746, REN. 3-3-11. INT. CL. 35.  
2,418,489, REN. 2-26-11. INT. CL. 42.
- GLOBAL DECOR, INC., ELK GROVE VILLAGE, IL:  
2,947,126, CANC. MULTIPLE CLASS, INT. CLS. 3 AND 11.
- GLOBAL FOOD TRADING CORP., BUTLER, NJ:  
3,940,134, PUB. 1-18-2011. INT. CL. 29.
- GLOBAL FORCE ENTERPRISES LLC, MIRAMAR, FL:  
3,940,738, PUB. 1-18-2011. INT. CL. 10.
- GLOBAL INDEMNITY GROUP, INC., BALA CYNWYD, SD:  
3,940,693, PUB. 1-18-2011. INT. CL. 36.
- GLOBAL MOVE MEDIA, LLC, BISHOP, GA:  
3,940,209, PUB. 1-18-2011. INT. CL. 35.
- GLOBAL NETWORK OF LAW FIRMS LLC, THE, BOULDER, CO:  
2,255,546, CANC. INT. CL. 35.
- GLOBAL NOVATIONS, LLC, BRIGHTON, MA:  
1,648,815, REN. 2-25-11. INT. CL. 16.
- GLOBAL PLASTICS, LP, SAN DIEGO, CA:  
3,942,345, INT. CL. 35.
- GLOBAL SPECTRUM, L.P., PHILADELPHIA, PA:  
3,942,167, INT. CL. 41.  
3,942,168, INT. CL. 41.
- GLOBAL SPECTRUM, LP, PINELLAS PARK, FL:  
2,865,109, CANC. INT. CL. 35.
- GLOBALEYE NETWORK INTELLIGENCE, LTD., LONDON, UNITED KINGDOM:  
2,864,775, CANC. INT. CL. 42.
- GLOBEOP FINANCIAL SERVICES, LLC, NEW YORK, NY:  
3,939,816, PUB. 1-18-2011. MULTIPLE CLASS, INT. CLS. 36 AND 42.
- GMAC INSURANCE MANAGEMENT CORPORATION, WINSTON-SALEM, NC:  
3,942,442, INT. CL. 36.

GN NETCOM, INC., NASHUA, NH:  
2,431,889. REN. 3-3-11. INT. CL. 9.

GOBIN, RUTH, SUNNYVALE, CA:  
2,865,279, CANC. MULTIPLE CLASS, INT. CLS. 14 AND 35.

GOCH, MARKUS, 30167 HANNOVER, FED REP GERMANY:  
3,940,984, MULTIPLE CLASS, INT. CLS. 6 AND 20.

GOD'S HEART DESIGNS, INC., PLANTATION, FL, GOD'S HEART DESIGNS, INC., PLANTATION, FL:  
2,421,734. REN. 3-1-11. MULTIPLE CLASS, INT. CLS. 16 AND 25.

GODWIN'S GATORLAND, INC., ORLANDO, FL:  
2,436,469. REN. 3-3-11. INT. CL. 41.

GOLD, ROCHELLE ANIXT, BIRMINGHAM, MI:  
2,865,606, CANC. INT. CL. 44.

GOLDEN HAWK INDUSTRIES S.A.S., RIONEGRO, ANTI-OQUIA, COLOMBIA:  
2,434,623. REN. 2-25-11. MULTIPLE CLASS, INT. CLS. 7 AND 12.

GOLDEN NEST, INC., ARCADIA, CA:  
2,440,491. REN. 2-25-11. INT. CL. 29.

GOLDEN PRIDE, INC., WEST PALM BEACH, FL:  
2,460,249. REN. 3-3-11. INT. CL. 5.

GOLF CART WORLD, INC., EASTMAN, GA:  
3,939,565, PUB. 3-30-2010. INT. CL. 12.

GOOD BIRD, INC., AUSTIN, TX:  
3,940,204, PUB. 1-18-2011. INT. CL. 41.

GOOD DOG FOUNDATION, THE, BROOKLYN, NY:  
2,864,582, CANC. INT. CL. 35.

GOOD FRIEND INC., WAUKESHA, WI:  
3,940,264, PUB. 1-18-2011. INT. CL. 41.

GOOD KARMA PUBLISHING, INC., ALBUQUERQUE, NM:  
2,496,179. REN. 3-1-11. INT. CL. 41.

GOOD PEOPLE, INC., BLOOMINGTON, MN:  
3,939,686, PUB. 1-18-2011. INT. CL. 35.

GOOD STEWARD SOFTWARE, LLC, COLORADO SPRINGS, CO:  
2,864,185, CANC. INT. CL. 9.

GOOD WAY INTERNATIONAL LIMITED, QUARRY BAY, HONG KONG:  
3,941,378, INT. CL. 9.

GOOD WISHES, LTD., NEW ALBANY, OH:  
2,865,489, CANC. INT. CL. 18.

GOODE SKIN LLC, NEW YORK, NY:  
2,468,037, CANC. INT. CL. 42.

GOODSON & ASSOCIATES, INC., LENEXA, KS:  
1,636,036. REN. 2-28-11. INT. CL. 9.

GOODWYN JR., LEE L., ALEXANDRIA, VA:  
3,941,022, INT. CL. 25.

GOODYEAR TIRE & RUBBER COMPANY, THE, AKRON, OH:  
861,678, CANC. U.S. CL. 35.

GOOFY PRODUCTS, INC., HAPPY VALLEY, OR:  
3,941,138, INT. CL. 9.

GORDON BRUSH MFG. CO., INC., COMMERCE, CA:  
1,151,068. REN. 2-28-11. INT. CL. 21.

GORDON, JULLIEN NEWTON, OAKLAND, CA:  
3,941,406, INT. CL. 16.

GOTTA HAVE IT COLLECTIBLES, INC., NEW YORK, NY:  
2,429,271. REN. 2-26-11. INT. CL. 35.

GOVERNMENT OF THE NORTHWEST TERRITORIES, THE, YELLOWKNIFE, CANADA:  
2,904,037, AM. INT. CL. 14.

GRAB NETWORKS HOLDINGS, INC., DULLES, VA:  
2,865,393, CANC. INT. CL. 9.

GRACE MCNAMARA, INC., ST. PAUL, MN:  
3,939,372, PUB. 1-18-2011. INT. CL. 35.

GRADIENT TECHNOLOGIES LLC, MEMPHIS, TN:  
2,394,306. REN. 3-2-11. INT. CL. 10.

GRADUATE MANAGEMENT ADMISSION COUNCIL, MCLEAN, VA:  
3,939,519, PUB. 1-18-2011. INT. CL. 9.

GRAFFITI JUNKTION LLC, ORLANDO, FL:  
3,940,537, PUB. 1-18-2011. INT. CL. 43.

GRAHAM ENGINEERING CORPORATION, YORK, PA:  
711,818. REN. 3-3-11. U.S. CL. 23 (INT. CL. 11).

GRAND TOURING VODKA, LLC, WINTER PARK, FL:  
3,940,299, PUB. 1-18-2011. INT. CL. 33.  
3,940,300, PUB. 1-18-2011. INT. CL. 33.

GRAND VISION GAMING, LLC, BILLINGS, MT:  
3,942,245, INT. CL. 9.  
3,942,307, INT. CL. 9.  
3,942,308, INT. CL. 9.  
3,942,309, INT. CL. 9.  
3,942,317, INT. CL. 9.  
3,942,318, INT. CL. 9.

GRANDMA LU'S SPICE CABINET, LLC, PLANO, TX:  
3,942,129, INT. CL. 30.

GRANDOE CORPORATION, THE, GLOVERSVILLE, NY:  
1,147,737. REN. 2-26-11. INT. CL. 25.

GRANIER, BRADY, TOLUCA LAKE, CA AND DECSEPEL, DAVID, TOLUCA LAKE, CA AND MARKEL, DANIEL, TOLUCA LAKE, CA AND NEWLAND, MICHELLE, TOLUCA LAKE, CA AND WELCH, THOMAS, TOLUCA LAKE, CA:  
3,940,671, PUB. 1-18-2011. INT. CL. 35.

GRANTHAM, MAYO, VAN OTTERLOO & CO. LLC., BOSTON, MA:  
2,444,569. REN. 2-25-11. INT. CL. 36.

GRAPE TECHNOLOGY GROUP, INC, BETHLEHEM, PA:  
2,559,945, CANC. MULTIPLE CLASS, INT. CLS. 35 AND 41.

GRATEFUL GRAFFITI, BEVERLY HILLS, CA:  
3,941,123, INT. CL. 25.

GRAY SPIRIT, INC., OKOBOJI, IA:  
2,864,757, CANC. INT. CL. 16.

GREAT WHITE SHARK ENTERPRISES, INC., WEST PALM BEACH, FL:  
3,940,417, PUB. 1-18-2011. INT. CL. 33.  
3,940,418, PUB. 1-18-2011. INT. CL. 33.

GREATER COLUMBUS CONVENTION & VISITOR BUREAU, CORP, COLUMBUS, OH:  
3,940,664, PUB. 1-18-2011. INT. CL. 35.

GREEN AG FARMING PRODUCTS, LLC, WINSTON-SALEM, NC:  
3,941,999, INT. CL. 1.

GREEN HOME PRINCIPLES LLC, PHILADELPHIA, PA, AKA GREENSTEPS LLC:  
3,941,178, MULTIPLE CLASS, INT. CLS. 41 AND 42.

GREEN MANUFACTURING INTERNATIONAL LIMITED, KWUN TONG, KOWLOON,, HONG KONG:  
3,940,415, PUB. 1-18-2011. INT. CL. 26.

GREEN MOUNTAIN COMMUNICATIONS, INC., PEMBROKE, NH:  
3,939,743, PUB. 1-18-2011. MULTIPLE CLASS, INT. CLS. 36, 37 AND 42.

GREEN REWARDS & AFFINITY LLC, GREENWICH, CT, DBA ENABLE TABLE:  
3,942,260, INT. CL. 9.

GREEN ROCK FASHION, INC, NEW YORK, NY:  
3,940,284, PUB. 1-18-2011. INT. CL. 25.

GREEN TILLAGE LLC, HOLTWOOD, PA:  
3,942,380, INT. CL. 31.

GREEN, STEPHEN, HAWTHORNE, CA AND JUNNE, EUNICE, HAWTHORNE, CA AND RY, PHALLY, HAWTHORNE, CA AND SOTO, AMALIA, HAWTHORNE, CA:  
3,939,831, PUB. 1-18-2011. MULTIPLE CLASS, INT. CLS. 38 AND 41.

GREENFEET LLC, CHICO, CA:  
3,941,527, INT. CL. 35.

GREENLEE TEXTRON INC., ROCKFORD, IL:  
1,147,071. REN. 2-26-11. INT. CL. 8.  
2,446,897. REN. 3-3-11. INT. CL. 8.

GREENWICH WORKSHOP, INC., THE, SEYMOUR, CT:  
1,630,813. REN. 3-2-11. INT. CL. 16.

GREG MATHIS, HOUSTON, TX:  
3,939,492, PUB. 1-18-2011. INT. CL. 41.

GREGORY A. MAHLOCH, OMAHA, NE:  
3,940,617, PUB. 1-18-2011. INT. CL. 9.

GREGORY GOLDSAND, SCOTTSDALE, AZ AND JOSH BRADLEY, ALBUQUERQUE, NM:  
3,940,703, PUB. 1-18-2011. INT. CL. 45.

- GRETAG-MACBETH HOLDING, AG, 8150 REGENSDORF, SWITZERLAND:  
2,865,723, CANC. INT. CL. 9.
- GRILLED CHEESE TO GO LLC, MILFORD, CT:  
3,942,302, INT. CL. 43.
- GRIMCO, INC., FENTON, MO:  
3,941,706, INT. CL. 2.  
3,941,707, INT. CL. 2.  
3,941,877, INT. CL. 20.
- GRINDERS AND SUCH, INC., MINERVA, OH, GRINDERS DELUXE, INC., CANTON, OH:  
1,650,944, REN. 2-26-11. INT. CL. 30.
- GROHE AG, FED REP GERMANY:  
3,939,983, PUB. 1-18-2011. MULTIPLE CLASS, INT. CLS. 11, 20 AND 21.  
3,939,986, PUB. 1-18-2011. MULTIPLE CLASS, INT. CLS. 11, 20 AND 21.  
3,939,987, PUB. 1-18-2011. MULTIPLE CLASS, INT. CLS. 11, 20 AND 21.
- GROMAX ENTERPRISES CORPORATION, IRVINE, CA:  
3,940,451, PUB. 1-18-2011. INT. CL. 7.
- GROOMECAPITAL.COM INC., MONTREAL, QUEBEC H3B 2B6, CANADA:  
2,368,756, CANC. INT. CL. 36.
- GROUP PUBLISHING, INC., LOVELAND, CO:  
3,941,001, MULTIPLE CLASS, INT. CLS. 9 AND 16.
- GROUPE HENRI HEULIEZ, 79140 CERIZAY, FRANCE:  
2,864,913, CANC. INT. CL. 12.
- GROUPE JAJ, FRANCE:  
3,939,995, PUB. 1-18-2011. MULTIPLE CLASS, INT. CLS. 18, 24 AND 25.
- GROUP360, INC., ST. LOUIS, MO:  
3,941,592, MULTIPLE CLASS, INT. CLS. 35, 39, 40, 41 AND 42.
- GROZ-BECKERT KG, D-72458 ALBSTADT, FED REP GERMANY:  
2,443,811, REN. 2-26-11. INT. CL. 7.
- GRT CORPORATION, STAMFORD, CT:  
2,864,476, CANC. MULTIPLE CLASS, INT. CLS. 35 AND 42.
- GRUMA CORPORATION, IRVING, TX:  
2,540,174, REN. 2-26-11. INT. CL. 30.
- GRUMPYFACE STUDIOS LLC, GILBERT, AZ:  
3,942,204, INT. CL. 42.
- GRUPO AGROINDUSTRIAL SAN MIGUEL, 5300 MEXICO CITY D.F, MEXICO:  
2,865,405, CANC. MULTIPLE CLASS, INT. CLS. 29 AND 31.
- GRUPO AGROINDUSTRIAL Y ALCOHOLERO DE MEXICO, S.A. DE C.V., MERIDA YUCATAN, MEXICO:  
2,369,593, CANC. INT. CL. 33.
- GRUPO BIMBO, S.A.B. DE C.V., MEXICO CITY, MEXICO:  
3,940,129, PUB. 1-18-2011. INT. CL. 30.  
3,940,281, PUB. 1-18-2011. INT. CL. 30.
- GRUPO GAMESA, S DE R.L DE C.V., NUEVO LEON, MEXICO, GAMESA, S.A., NUEVO LEON, MEXICO:  
1,157,500, REN. 3-2-11. INT. CL. 30.
- GRUPO INTERCOOP INTERCOOPERACION,; AGROALIMENTARIA, S.L., SPAIN:  
3,939,952, PUB. 1-18-2011. INT. CL. 29.
- GRUPO INTERNACIONAL DE EXPORTACION, S.A. DE C.V., ZAPOPAN, JALISCO, MEXICO:  
3,940,779, PUB. 1-18-2011. INT. CL. 33.  
3,940,788, PUB. 1-18-2011. INT. CL. 33.
- GS BATTERY (U.S.A.) INC., ROSWELL, GA:  
3,941,512, INT. CL. 9.
- GS ENTERPRISES LLC, SAN ANTONIO, TX:  
3,942,389, INT. CL. 43.  
3,942,390, INT. CL. 43.  
3,942,391, INT. CL. 43.  
3,942,392, INT. CL. 43.
- GSLE SUBCO L.L.C., CHARLOTTE, NC:  
2,865,455, CANC. MULTIPLE CLASS, INT. CLS. 7 AND 9.
- GSM A LTD., ATLANTA, GA:  
3,941,317, MULTIPLE CLASS, INT. CLS. 35, 38 AND 41.
- GUARDIAN FIBERGLASS, INC., ALBION, MI:  
2,368,557, CANC. INT. CL. 35.
- GUIDANT CORPORATION, INDIANAPOLIS, IN:  
2,367,649, CANC. INT. CL. 42.
- GUILHERME CARDOSO DE CARDOSO, CARLSBAD, CA, AKA BILL CARDOSO:  
3,940,485, PUB. 1-18-2011. INT. CL. 9.  
3,940,487, PUB. 1-18-2011. INT. CL. 9.  
3,940,491, PUB. 1-18-2011. INT. CL. 9.
- GUITAR.COM, LLC, FARMINGDALE, NY:  
2,433,066, REN. 3-3-11. INT. CL. 25.
- GULF PACIFIC, INC., HOUSTON, TX:  
3,941,039, INT. CL. 30.
- GULLIVER INTERNATIONAL CO., LTD., JAPAN:  
3,939,985, PUB. 1-18-2011. INT. CL. 35.
- GUNDERSON LLC, PORTLAND, OR:  
1,582,456, REN. 3-2-11. INT. CL. 12.
- GURUKRIPA FOODS INC., RICHMOND HILL, NY:  
3,941,105, INT. CL. 30.
- GUTIERREZ, MARTIN JR., SAN ANTONIO, TX:  
3,942,339, INT. CL. 37.
- GUTZEIT, JOACHIM, NORCROSS, GA:  
2,864,084, CANC. INT. CL. 11.
- GYEONGSANGBUK-DO, BUK-GU, DEAGU, REPUBLIC OF KOREA:  
3,939,982, PUB. 1-18-2011. INT. CL. 31.
- G3 DISTRIBUTORS, LLC, ATLANTA, GA:  
3,940,352, PUB. 1-18-2011. INT. CL. 30.
- H.O.WOLDING, INC., AMHERST, WI:  
2,455,132, REN. 3-3-11. INT. CL. 39.
- H.S. THAI INTERNATIONAL, INC., SAN FRANCISCO, CA:  
2,864,618, CANC. INT. CL. 30.
- HACKER KUCHEN GMBH & CO. KG, D-32289 RODINGHAUSEN, FED REP GERMANY:  
2,864,431, CANC. INT. CL. 20.
- HADASH, KIMBERLY A., NEWPORT BEACH, CA:  
2,527,042, REN. 3-3-11. INT. CL. 22.
- HAGGAR CLOTHING CO., DALLAS, TX:  
2,367,399, CANC. INT. CL. 25.
- HAIMOVICI, ALEK, MONTECITO, CA:  
3,940,225, PUB. 1-18-2011. INT. CL. 41.
- HAIN-CELESTIAL CANADA, ULC, DELTA CANADA, BRITISH COLUMBIA:  
2,864,986, CANC. INT. CL. 29.
- HAIRDREAMS HAARHANDELS GMBH, GRAZ, AUSTRIA:  
2,919,392, CANC. INT. CL. 7.
- HALCYON DESIGN LLC, FULLERTON, CA, DBA HALCYON DESIGN:  
3,939,407, PUB. 1-18-2011. INT. CL. 35.
- HALDOR TOPSOE A/S, DK-2800 KGS. LYNGBY, DENMARK:  
2,930,247, CANC. INT. CL. 1.
- HALDOR TOPSØE A/S, DENMARK:  
3,940,059, PUB. 1-18-2011. MULTIPLE CLASS, INT. CLS. 4, 40 AND 42.
- HALE PRODUCTS, INC., CONSHOHOCKEN, PA, HURST PERFORMANCE, INC., WARMINSTER, PA:  
1,165,246, REN. 2-26-11. INT. CL. 7.
- HALE, NATHAN S., MT. PLEASANT, SC:  
3,941,362, MULTIPLE CLASS, INT. CLS. 41 AND 43.
- HALL, LAWRENCE D., MENDOTA HEIGHTS, MN:  
3,598,015, CANC. INT. CL. 39.
- HALLMARK BUSINESS CONNECTIONS, INC., MINNEAPOLIS, MN:  
2,369,268, CANC. INT. CL. 35.
- HAM, IRA, SANTA ANA, CA:  
3,942,310, INT. CL. 41.
- HAMEL, CHAD MICHAEL, MIDWEST CITY, OK:  
2,864,756, CANC. MULTIPLE CLASS, INT. CLS. 25 AND 28.
- HAMEL, GREGORY A, SODA SPRINGS, CA AND SHIVERS, ERSY C, SODA SPRINGS, CA:  
2,864,997, CANC. INT. CL. 44.
- HAMEL, SCOTT W, ESTERO, FL:  
3,939,832, PUB. 1-18-2011. INT. CL. 36.
- HAMMOND, CRAIG M., SAN FRANCISCO, CA:  
2,864,744, CANC. INT. CL. 35.

HAMPTON ROADS EDUCATIONAL TELECOMMUNICATIONS ASSOCIATION, INC., NORFOLK, VA, DBA WHRO:  
3,939,524, PUB. 11-16-2010. INT. CL. 38.

HANDI QUILTER, INC., NORTH SALT LAKE, UT:  
3,942,425, INT. CL. 9.  
3,942,426, INT. CL. 16.

HANDS HIGH SOFTWARE, INC., EAST PALO ALTO, CA:  
2,368,310, CANC. INT. CL. 9.

HANGER PROSTHETICS & ORTHOTICS, INC., AUSTIN, TX:  
3,941,943, INT. CL. 10.

HANKOOK TIRE CO., LTD., SEOUL, REPUBLIC OF KOREA:  
3,939,495, PUB. 1-18-2011. INT. CL. 12.

HANNAH, SCOTT WILLIAM, SAN CLEMENTE, CA, DBA REDLINE STUDIOS:  
2,571,828, CANC. INT. CL. 41.

HANNAN, JEFFREY, SAN FRANCISCO, CA:  
2,393,425, CANC. INT. CL. 35.

HANSBERRY, ETHEL LOVATA, UNION CITY, GA:  
3,940,297, PUB. 1-18-2011. INT. CL. 35.

HANSEATIC LLOYD AG, SWITZERLAND:  
3,939,915, PUB. 1-18-2011. MULTIPLE CLASS, INT. CLS. 35, 36, 39 AND 42.

HANSEN BEVERAGE COMPANY, CORONA, CA:  
3,939,395, PUB. 1-18-2011. MULTIPLE CLASS, INT. CLS. 5 AND 32.

HANSEN, JAMES R. JR., CHICAGO, IL:  
2,865,382, CANC. INT. CL. 9.

HAPA HALE INTERNATIONAL, LLC, HONOLULU, HI:  
3,941,628, INT. CL. 35.

HAPPY ENDINGS MASSAGE OIL, LLC, SOLON, OH:  
3,940,700, PUB. 1-18-2011. INT. CL. 3.

HAPPY HOUSE, NORTHRIDGE, CA:  
3,942,038, INT. CL. 16.

HAPPY JUNK LLC, LAS VEGAS, NV:  
3,939,616, PUB. 10-12-2010. INT. CL. 3.

HARBOR FINANCIAL GROUP, INC, GREEN BAY, WI:  
3,940,908, PUB. 1-18-2011. INT. CL. 36.

HARBOR FREIGHT TOOLS USA, INC., CALABASAS, CA:  
2,437,230, REN. 2-26-11. INT. CL. 14.

HARBOR PLANNING GROUP, INC., THE, CAMBRIDGE, MA:  
2,484,346, REN. 2-28-11. MULTIPLE CLASS, INT. CLS. 36 AND 37.

HARDING, CHARLES E., SCHNECKSVILLE, PA:  
2,490,789, REN. 3-3-11. INT. CL. 42.

HARDWARE RESOURCES, INC., BOSSIER CITY, LA:  
3,940,338, PUB. 1-18-2011. INT. CL. 6.

HARLAND CLARKE CORP., SAN ANTONIO, TX, BANCO CORPORATION, LTD., SAN FRANCISCO, CA:  
717,603, REN. 3-3-11. U.S. CL. 37 (INT. CL. 16).

HARLAND CLARKE CORP., SAN ANTONIO, TX:  
1,162,689, REN. 3-3-11. INT. CL. 16.

HARLAND FINANCIAL SOLUTIONS, INC., PORTLAND, OR:  
2,481,132, REN. 3-1-11. MULTIPLE CLASS, INT. CLS. 38 AND 42.

HARMAN INTERNATIONAL INDUSTRIES, INCORPORATED, NORTHRIDGE, CA:  
1,613,674, REN. 2-26-11. INT. CL. 42.  
3,940,158, PUB. 1-18-2011. INT. CL. 9.

HARMON, NICK L., ALBUQUERQUE, NM:  
3,941,131, MULTIPLE CLASS, INT. CLS. 17 AND 19.

HAROLD G. MIDDLETON, NORMANDY PARK, WA:  
2,430,890, REN. 2-26-11. INT. CL. 9.

HARPERCOLLINS PUBLISHERS LIMITED, GLASGOW, UNITED KINGDOM:  
3,939,413, PUB. 4-14-2009. MULTIPLE CLASS, INT. CLS. 9 AND 41.  
3,939,414, PUB. 4-14-2009. MULTIPLE CLASS, INT. CLS. 9 AND 41.

HARPS, LAQUINTA, SAINT JOHNS, FL:  
3,941,609, INT. CL. 14.

HARRIS TRUST AND SAVINGS BANK, CHICAGO, IL:  
2,864,894, CANC. INT. CL. 36.

HARRIS, AL, SALAMANCA, NY:  
3,942,341, MULTIPLE CLASS, INT. CLS. 3, 4 AND 34.

HARRIS, CHRISTINE, BALTIMORE, MD, DBA GREEN AFRO DIVA - NATURAL LIVING WITH FLAVA:  
3,940,404, PUB. 1-18-2011. INT. CL. 3.

HARRY LUM, PLAYA DEL REY, CA:  
3,939,605, PUB. 1-18-2011. INT. CL. 25.  
3,939,673, PUB. 1-18-2011. INT. CL. 25.

HARTFORD FIRE INSURANCE COMPANY, HARTFORD, CT:  
3,941,285, INT. CL. 42.

HARTL CRUSHTEK, ATLANTA, GA:  
2,526,731, CANC. INT. CL. 7.

HARTL CRUSHTEK, L.L.C., ATLANTA, GA:  
2,526,730, CANC. INT. CL. 7.

HARTWELL INDUSTRIES, INC., HARTWELL, GA:  
2,864,778, CANC. INT. CL. 25.

HARVEL PLASTICS, INC., EASTON, PA:  
2,511,632, REN. 2-25-11. INT. CL. 17.

HARVEY EARL JACOBS, MIDLOTHIAN, VA:  
3,941,485, INT. CL. 41.

HARVEY PRINCE LLP, PRINCETON JUNCTION, NJ:  
3,770,283, CANC. INT. CL. 3.

HASBRO, INC., PAWTUCKET, RI, MILTON BRADLEY COMPANY, SPRINGFIELD, MA:  
544,328, REN. 3-2-11. U.S. CL. 22 (INT. CL. 28).

HASBRO, INC., PAWTUCKET, RI:  
2,368,931, CANC. INT. CL. 28.  
2,865,522, CANC. INT. CL. 28.  
3,940,219, PUB. 10-12-2010. INT. CL. 25.

HASEKO (HAWAII), INC., EWA BEACH, HI, HASEKO (NEW YORK), INC., NEW YORK, NY:  
1,642,267, REN. 2-25-11. MULTIPLE CLASS, INT. CLS. 36 AND 37.

HASIE CORPORATION, SAN MARCOS, CA:  
3,941,299, MULTIPLE CLASS, INT. CLS. 25 AND 29.

HATZ SPAIN, S.A., NULES, CASTELLON, SPAIN:  
3,939,596, PUB. 1-18-2011. INT. CL. 19.

HAURI INC., SEOUL, REPUBLIC OF KOREA:  
2,865,027, CANC. INT. CL. 42.

HAWKER BEECHCRAFT CORPORATION, WICHITA, KS:  
3,940,827, PUB. 1-18-2011. INT. CL. 12.

HAYASHI WORLDWIDE LLC, HIGHLANDS RANCH, CO:  
3,939,876, PUB. 1-18-2011. INT. CL. 3.

HAYDEN ENTERPRISES, INC, REDMOND, OR, DBA HAYDEN HOMES:  
2,871,281, CANC. INT. CL. 37.

HAYES BICYCLE GROUP, INC., MEQUON, WI:  
2,425,060, REN. 2-28-11. INT. CL. 12.

HAYNEEDLE, INC., OMAHA, NE:  
3,940,847, PUB. 1-18-2011. INT. CL. 35.

HBI BRANDED APPAREL ENTERPRISES, LLC, WINSTON-SALEM, NC:  
2,865,704, CANC. INT. CL. 25.  
3,941,937, INT. CL. 25.

HCR HEALTHCARE, LLC, TOLEDO, OH:  
3,939,580, PUB. 10-12-2010. MULTIPLE CLASS, INT. CLS. 41 AND 44.

HDN DEVELOPMENT CORPORATION, WINSTON-SALEM, NC, KRISPY KREME DOUGHNUT COMPANY, WINSTON-SALEM, NC:  
539,165, REN. 3-3-11. U.S. CL. 46 (INT. CLS. 1, 5, 29, 30, 31 AND 32).

HDS IP HOLDING, LLC, LAS VEGAS, NV:  
720,199, REN. 3-3-11. U.S. CL. 6 (INT. CL. 1).

HEAD SPORT GMBH, KENNELBACH, AUSTRIA:  
2,367,643, CANC. INT. CL. 28.

HEADHUNTER SYSTEMS, LTD., LONDON, UNITED KINGDOM:  
3,941,903, INT. CL. 35.  
3,941,907, INT. CL. 42.

HEADSPIN SOFTWARE, LLC, BURLINGTON, MA:  
3,940,773, PUB. 1-18-2011. INT. CL. 42.

HEAFNER TIRE GROUP, INC., CHARLOTTE, NC TO AMERICAN TIRE DISTRIBUTORS, INC., HUNTERS-VILLE, NC:  
2,368,950, CANC. U.S. CL. 200.

- HEALTH CARE ACCESS NOW, CINCINNATI, OH:  
3,941,183, INT. CL. 35.
- HEALTH MANAGEMENT RESOURCES, INC., SALISBURY, NC:  
3,805,797, CANC. INT. CL. 35.
- HEALTH SHOPPE VITAMINS AND NATURAL FOODS, INC., JACKSONVILLE, FL:  
2,553,193, CANC. INT. CL. 35.
- HEALTH TELEVISION SYSTEM INC., THE, TORONTO, ONTARIO, CANADA:  
2,434,344, REN. 2-25-11. INT. CL. 9.
- HEALTHALND INC., GLENWOOD, MN:  
3,941,104, MULTIPLE CLASS, INT. CLS. 9, 35, 37, 40, 41 AND 42.
- HEALTHCARE COMMUNICATIONS GROUP, EL SEGUNDO, CA:  
2,454,209, REN. 3-2-11. INT. CL. 35.
- HEALTHFUSION, INC., SOLANA BEACH, CA:  
3,942,326, INT. CL. 42.
- HEALTHTRAN, LLC, GREENWOOD VILLAGE, CO:  
3,942,071, INT. CL. 35.
- HEALTHY CHILDREN PROJECT, INC., EAST SANDWICH, MA, DBA ACADEMY OF LACTATION POLICY AND PRACTICE, INC.:  
3,939,681, PUB. 1-18-2011. U.S. CL. B.
- HEALTHY INTERACTIONS, INC, SYLVANIA, OH:  
3,941,507, INT. CL. 44.
- HEARST TELEVISION, INC., NEW YORK, NY:  
1,630,385, CANC. INT. CL. 41.
- HEARTLAND COMMUNICATIONS GROUP, INC., FORT DODGE, IA, HOT LINE, INC., FT. DODGE, IA:  
1,158,077, REN. 3-2-11. INT. CL. 16.
- HEARTLAND GROUP LIMITED, NELSON, NEW ZEALAND:  
3,939,544, PUB. 1-18-2011. INT. CL. 29.
- HEARTLAND PAYMENT SYSTEMS, INC., PRINCETON, NJ:  
3,941,413, INT. CL. 42.
- HEARTWARE, INC., MIAMI LAKES, FL:  
3,940,614, PUB. 1-18-2011. INT. CL. 18.
- HEATH & SHERWOOD (1964) LIMITED, KIRKLAND LAKE, ONTARIO P2N 3J2, CANADA:  
2,369,062, CANC. INT. CL. 7.
- HEATHER J. BAILEY, TIPP CITY, OH:  
3,940,206, PUB. 1-18-2011. INT. CL. 28.
- HEAVEN HILL DISTILLERS, INC, BARDSTOWN, KY, JOSEPH E. SEAGRAM & SONS, INC., NEW YORK, NY, AKA WILSON DISTILLING COMPANY:  
1,178,406, REN. 3-3-11. INT. CL. 33.
- HEB GROCERY COMPANY, LP, SAN ANTONIO, TX:  
3,939,486, PUB. 1-18-2011. INT. CL. 35.
- HEBEI XMF TOOLS GROUP CO., LTD, CHINA:  
3,939,932, PUB. 1-18-2011. INT. CL. 7.
- HEDSTROM CORPORATION, ARLINGTON HEIGHTS, IL:  
2,864,835, CANC. INT. CL. 16.
- HEDSTROM CORPORATION, BEDFORD, PA:  
2,865,582, CANC. INT. CL. 28.
- HEIGHT OF LAND PUBLICATIONS, JEFFERSONVILLE, VT, DBA BACKCOUNTRY MAGAZINE:  
2,433,065, REN. 2-26-11. INT. CL. 16.
- HEIMANN, JURGEN STEFFEN, SHERMAN OAKS, CA:  
2,368,538, CANC. INT. CL. 41.
- HEINEKEN BROUWERIJEN B.V., NETHERLANDS:  
3,940,024, PUB. 1-18-2011. MULTIPLE CLASS, INT. CLS. 18, 25 AND 32.
- HELEN OF TROY LIMITED, ST. MICHAEL, BARBADOS:  
1,166,031, REN. 3-3-11. INT. CL. 3.
- HELENA HOLDING COMPANY, WILMINGTON, DE:  
2,478,347, REN. 3-3-11. INT. CL. 5.  
3,941,057, INT. CL. 42.
- HELLASMED LLC, HOUSTON, TX:  
3,941,205, INT. CL. 44.
- HELM INSTRUMENT COMPANY, INC., MAUMEE, OH:  
1,163,531, REN. 2-26-11. INT. CL. 9.
- HELP ME SPEAK CARDS, INC., EL CAJON, CA:  
3,941,977, INT. CL. 16.
- HENDERSON, TIM, CHICO, CA:  
3,941,192, INT. CL. 25.
- HENDRICKSON, L AMY, SPRING LAKE, MI:  
3,940,145, PUB. 1-18-2011. INT. CL. 16.
- HENKEL AG & CO. KGAA, DUESSELDORF, FED REP GERMANY:  
2,864,100, CANC. INT. CL. 3.
- HENKEL CONSUMER GOODS INC., SCOTTSDALE, AZ:  
3,941,589, INT. CL. 3.
- HENKEL CORPORATION, ROCKY HILL, CT:  
915,380, REN. 2-26-11. U.S. CL. 15 (INT. CL. 4).
- HERAEUS NOBLELIGHT GMBH, 63450 HANAU, FED REP GERMANY:  
2,430,893, REN. 3-1-11. INT. CL. 11.
- HERALD OF TRUTH MINISTRIES, INC., ABILENE, TX:  
3,940,377, PUB. 1-18-2011. MULTIPLE CLASS, INT. CLS. 16 AND 41.
- HERBALS USA, LLC, SEWICKLEY, PA:  
3,942,044, INT. CL. 5.
- HERBERT L. JAMISON & CO., LLC, WEST ORANGE, NJ:  
3,939,654, PUB. 1-18-2011. MULTIPLE CLASS, INT. CLS. 35 AND 36.
- HERCULES INCORPORATED, WILMINGTON, DE:  
3,941,911, INT. CL. 1.
- HERMAN MILLER, INC., ZEELAND, MI:  
3,942,281, INT. CL. 20.
- HERMES INTERNATIONAL, 75008 PARIS, FRANCE:  
2,447,278, CANC. MULTIPLE CLASS, INT. CLS. 8, 9, 20, 24, 28 AND 34.
- HERMES INTERNATIONAL, F-75008 PARIS, FRANCE:  
3,939,358, PUB. 1-18-2011. INT. CL. 18.
- HERON VENTURES, LTD., LA CONNER, WA, DBA NATURAL BEAUTY GROUP:  
3,941,447, INT. CL. 3.
- HEROTAINMENT, LLC, SADDLE RIVER, NJ:  
3,942,041, INT. CL. 41.
- HERTZ FARM MANAGEMENT, INC., NEVADA, IA:  
2,431,411, REN. 2-25-11. INT. CL. 35.  
2,435,077, REN. 2-25-11. INT. CL. 36.  
2,440,684, REN. 2-25-11. MULTIPLE CLASS, INT. CLS. 35 AND 36.
- HESKA CORPORATION, LOVELAND, CO:  
2,454,228, REN. 2-25-11. INT. CL. 10.
- HESKA CORPORATION, LOVELAND, CO, HESKA CORPORATION, LOVELAND, CO:  
2,494,527, REN. 2-28-11. INT. CL. 5.
- HESKA CORPORATION, LOVELAND, CO:  
2,509,741, REN. 3-2-11. INT. CL. 10.
- HESS CORPORATION, NEW YORK, NY:  
3,941,403, INT. CL. 35.
- HFP PRODUCTS LLC, BIG PRAIRIE, OH:  
3,942,178, INT. CL. 5.
- HI-SPEED MEDIA, INC., SHERMAN OAKS, CA:  
2,865,208, CANC. INT. CL. 35.
- HI-TECH SMART SYSTEMS, INC., KANEOHE, HI, FORMERLY HI-TECH LEASING, INC.:  
3,940,678, PUB. 1-18-2011. INT. CL. 9.
- HI-TECH WELDING AND FORMING, INC., EL CAJON, CA:  
3,941,011, INT. CL. 40.  
3,941,012, INT. CL. 40.
- HIERARCHY, LLC, WAYNE, MI, DBA HIERARCHY, LLC:  
3,942,039, INT. CL. 41.
- HIGH END SYSTEMS, INC., AUSTIN, TX:  
2,865,581, CANC. INT. CL. 11.
- HIGH SPEED PRODUCTIONS, INC., SAN FRANCISCO, CA:  
2,431,047, REN. 2-25-11. INT. CL. 14.
- HIGH TECH DESIGN SAFETY, LLC, AUSTIN, TX:  
3,941,357, INT. CL. 11.
- HIGHBANK ADVISORS LLC, PHOENIX, MD:  
3,942,120, MULTIPLE CLASS, INT. CLS. 35 AND 36.
- HIGHLIGHTS FOR CHILDREN, INC., COLUMBUS, OH:  
3,939,646, PUB. 1-18-2011. INT. CL. 16.
- HIGHLINE CAPITAL MANAGEMENT, LLC, NEW YORK, NY:  
2,502,179, REN. 2-26-11. INT. CL. 36.
- HILARY LIDESTRI, PLANO, TX:  
3,941,622, INT. CL. 45.
- HILL, ANNE A., SEBASTOPOL, CA:  
2,864,723, CANC. INT. CL. 35.

HILTON, PARIS, BEVERLY HILLS, CA:  
3,940,706, PUB. 1-18-2011. INT. CL. 18.

HINKLER BOOKS PTY LTD, AUSTRALIA:  
3,940,056, PUB. 1-18-2011. MULTIPLE CLASS, INT. CLS. 9, 16, 28, 35 AND 41.

HINTON, SR, ANTHONY, FREDERICKSBURG, VA:  
3,941,002, INT. CL. 37.

HIP SOLUTIONS, L.L.P., AUSTIN, TX:  
2,864,924, CANC. INT. CL. 21.

HISPANIC FOOD DISTRIBUTORS, INC., MCALLEN, TX:  
2,368,521, CANC. INT. CL. 31.

HITCHINER MANUFACTURING CO., INC., MILFORD, NH:  
3,940,261, PUB. 1-18-2011. INT. CL. 40.

HKS TECHNOLOGY GMBH, 78224 SINGEN, FED REP GERMANY:  
2,864,114, CANC. MULTIPLE CLASS, INT. CLS. 7 AND 42.

HLT DOMESTIC IP LLC, MCLEAN, VA:  
2,478,091. REN. 2-26-11. INT. CL. 42.  
2,478,190. REN. 2-26-11. INT. CL. 42.  
2,480,023. REN. 3-2-11. INT. CL. 42.  
2,480,064. REN. 2-25-11. INT. CL. 42.

HLT DOMESTIC IP LLC, MEMPHIS, TN:  
2,482,431. REN. 2-25-11. INT. CL. 42.

HME, INCORPORATED, WYOMING, MI:  
2,475,909. REN. 3-3-11. INT. CL. 40.

HMR ACQUISITION COMPANY, INC., SOUTH BEND, IN, DBA HACIENDA MEXICAN RESTAURANTS:  
2,466,961. REN. 2-26-11. INT. CL. 30.

HNI TECHNOLOGIES INC., MUSCATINE, IA:  
3,942,103, INT. CL. 20.

HOBART BROTHERS COMPANY, TROY, OH:  
2,477,495. REN. 2-26-11. INT. CL. 7.

HOERLE, DAWNA M., SEATTLE, WA:  
3,940,748, PUB. 1-18-2011. INT. CL. 44.

HOFFMAN HOUSE CIGAR & TOBACCO LLC, CHICAGO, IL:  
3,942,054, INT. CL. 34.

HOFFMASTER GROUP, INC., OSHKOSH, WI:  
2,864,451, CANC. MULTIPLE CLASS, INT. CLS. 16 AND 21.  
3,941,271, MULTIPLE CLASS, INT. CLS. 16, 20, 21, 24 AND 28.

HOLIDAY SYSTEMS INTERNATIONAL OF NEVADA, LAS VEGAS, NV:  
2,429,468. REN. 3-2-11. INT. CL. 36.  
2,431,029. REN. 2-26-11. INT. CL. 36.  
2,433,090. REN. 2-26-11. INT. CL. 36.  
2,433,091. REN. 2-26-11. INT. CL. 36.

HOLMES, LAUREN L., TORONTO, ONTARIO, CANADA:  
3,941,535, MULTIPLE CLASS, INT. CLS. 9, 35, 41 AND 45.

HOM FURNITURE, INC., COON RAPIDS, MN:  
3,940,556, PUB. 1-18-2011. INT. CL. 35.

HOME CINEMA DESIGNS, INC., NEW YORK, NY:  
2,368,780, CANC. INT. CL. 35.

HOME HEALTH CARE MANAGEMENT, INC., WYOMISSING, PA:  
2,540,388. REN. 3-3-11. INT. CL. 42.

HOME HEALTHCARE LABORATORY OF AMERICA, INC., FRANKLIN, TN:  
2,864,085, CANC. MULTIPLE CLASS, INT. CLS. 42 AND 44.

HOME MARKET FOODS, INC., NORWOOD, MA:  
2,742,969, CANC. INT. CL. 29.

HOME PRODUCTS INTERNATIONAL - NORTH AMERICA, INC., CHICAGO, IL:  
2,411,357, COR. INT. CL. 21.

HEMOCARE CONSULTANTS UNLIMITED, INC., TRACY, CA:  
3,939,685, PUB. 1-18-2011. INT. CL. 45.

HOMEGOODS, INC., FRAMINGHAM, MA:  
3,942,445, INT. CL. 35.

HOMES AND AGENTS, INC., WESTON, FL:  
2,865,215, CANC. INT. CL. 42.

HOMES FOR AMERICA, INC., ANNAPOLIS, MD:  
2,863,898, CANC. INT. CL. 37.

HOMESKILLS, LLC, CHESTERFIELD, MO:  
2,864,868, CANC. MULTIPLE CLASS, INT. CLS. 16 AND 41.

HOMESTEAD PUBLISHING COMPANY, BEL AIR, MD:  
2,459,239. REN. 3-3-11. INT. CL. 16.

HOMESTEADERS LIFE COMPANY, WEST DES MOINES, IA:  
2,431,587. REN. 2-28-11. INT. CL. 36.

HOMIESHOP PROPERTIES, L.L.C., HERCULES, CA:  
3,942,060, INT. CL. 41.

HONG, WAN KI, SEOUL, REPUBLIC OF KOREA:  
3,941,478, INT. CL. 9.  
3,941,479, INT. CL. 25.

HOOCHI COOCHI WAX STUDIO, INC., LANTANA, FL:  
3,940,735, PUB. 1-18-2011. INT. CL. 44.

HOOD RIVER DISTILLERS, INC., HOOD RIVER, OR:  
2,436,924. REN. 2-26-11. INT. CL. 33.

HOOD, YUSEF, CHICAGO, IL, DBA HOODFILMS:  
3,941,216, INT. CL. 41.

HOOK-ON EARRINGS LLC, REHOBOTH, MA, DBA MERIDYTH MAX, HOOK-ON EARRINGS:  
3,939,582, PUB. 1-18-2011. INT. CL. 14.

HOOVER & STRONG, INC., RICHMOND, VA:  
2,369,547, CANC. INT. CL. 14.

HOOVER GROUP, INC., HOUSTON, TX:  
2,376,386. REN. 2-26-11. INT. CL. 20.

HOPE LOANPORT, INC., WASHINGTON, DC:  
3,941,743, INT. CL. 36.

HORAN, DALE, ARNOLD, MD AND CORRIELL, KEITH, ARNOLD, MD AND DUNCAN, MELISSA, NEW HOPE, PA AND DUNCAN, ADAM, NEW HOPE, PA:  
2,864,938, CANC. INT. CL. 41.

HORIAN, RICHARD, CORONA, CA, DBA BRUXCURE:  
3,941,493, INT. CL. 10.

HORIBA JOBIN YVON INC., EDISON, NJ:  
2,864,245, CANC. INT. CL. 9.

HORIPRO ENTERTAINMENT GROUP, INC., LOS ANGELES, CA:  
3,940,175, PUB. 1-18-2011. INT. CL. 41.  
3,940,279, PUB. 1-18-2011. INT. CL. 41.

HORNELL BREWING COMPANY, INC., LAKE SUCCESS, NY:  
2,463,393, CANC. INT. CL. 32.

HOROSCOPE.COM, INC., SAN FRANCISCO, CA:  
3,940,150, PUB. 1-18-2011. INT. CL. 45.

HORSEWARE PRODUCTS LTD., DUNDALK, COUNTY LOUTH, IRELAND:  
2,488,778, COR. INT. CL. 25.

HORTECH, INC., SPRING LAKE, MI:  
3,942,331, INT. CL. 21.

HORVATH, FRANK JERRY, ROCKVALE, TN:  
3,940,488, PUB. 1-18-2011. INT. CL. 21.

HOSANNA, ALBUQUERQUE, NM, DBA FAITH COMES BY HEARING:  
3,940,366, PUB. 1-18-2011. INT. CL. 9.

HOSMER DORRANCE CORPORATION, CAMPBELL, CA:  
1,625,834. REN. 2-26-11. INT. CL. 10.

HOSPITALITY USA HOLDINGS, LLC, HOUSTON, TX:  
3,939,439, PUB. 1-18-2011. INT. CL. 43.

HOT-CAN SDN. BHD., KUALA LUMPUR, MALAYSIA:  
3,942,402, INT. CL. 11.

HOUGARDY, MARK D, SUNNYVALE, CA, DBA GLYPH-GUY LLC:  
3,939,808, PUB. 1-18-2011. INT. CL. 35.

HOUGHTON MIFFLIN COMPANY, BOSTON, MA:  
2,498,661. REN. 3-2-11. INT. CL. 41.

HOUGHTON MIFFLIN HARCOURT PUBLISHING COMPANY, BOSTON, MA:  
2,438,599. REN. 3-3-11. INT. CL. 16.  
2,444,444. REN. 3-3-11. INT. CL. 16.

HOURLY MEDIA, L.L.C., ROYAL OAK, MI:  
3,941,825, INT. CL. 35.

HOUSE FOODS CORPORATION, OSAKA, JAPAN:  
3,942,364, MULTIPLE CLASS, INT. CLS. 5 AND 32.

HOUSING 1 SOURCE, LLC, SAN ANTONIO, TX:  
3,942,195, INT. CL. 35.

HOW TOWN, INC., NEW YORK, NY:  
2,368,120, CANC. INT. CL. 16.

- HOYA CORPORATION, TOKYO, JAPAN:  
2,864,513, CANC. INT. CL. 9.
- HP HOOD LLC, LYNNFIELD, MA:  
1,635,602, REN. 2-25-11. INT. CL. 29.
- HROMADKA, MARK, PINEVILLE, LA AND HROMADKA, TAMMY, PINEVILLE, LA:  
3,940,809, PUB. 1-18-2011. INT. CL. 25.
- HSBC FINANCE CORPORATION, METTAWA, IL:  
2,430,213, REN. 2-26-11. INT. CL. 36.
- HSI IP, INC., GEORGE TOWN, GRAND CAYMAN, CAYMAN ISLANDS:  
2,865,028, CANC. INT. CL. 20.
- HTC CORP., AUGUSTA, GA, AKA HEALING THRU CARING, INC.:  
3,940,687, PUB. 1-18-2011. INT. CL. 5.
- HTCERAMIX S.A., SWITZERLAND:  
3,940,062, PUB. 1-18-2011. MULTIPLE CLASS, INT. CLS. 7 AND 9.
- HU-FRIEDY MFG. CO., LLC, CHICAGO, IL:  
3,941,259, INT. CL. 10.
- HU-YU, INC., PALM DESERT, CA, DBA CITY WOK:  
2,519,902, REN. 2-28-11. INT. CL. 42.
- HUBBARD FEEDS INC., MANKATO, MN:  
2,429,079, REN. 3-2-11. INT. CL. 31.
- HUBBELL INCORPORATED, ORANGE, CT:  
2,864,337, CANC. INT. CL. 9.
- HUECK RHEINISCHE GMBH, 41747 VIERSSEN, FED REP GERMANY:  
3,940,011, PUB. 1-18-2011. MULTIPLE CLASS, INT. CLS. 7, 37, 40 AND 42.
- HUFFY CORPORATION, CENTERVILLE, OH:  
2,435,957, REN. 2-28-11. INT. CL. 28.
- HUISONG PHARMACEUTICALS, HANGZHOU, CHINA:  
3,940,144, PUB. 1-18-2011. INT. CL. 5.
- HUMAN GENOME SCIENCE, INC., ROCKVILLE, MD:  
2,865,417, CANC. INT. CL. 5.
- HUMANE SOCIETY OF THE UNITED STATES, THE, WASHINGTON, DC:  
2,436,424, REN. 2-26-11. INT. CL. 16.
- HUMANTECH, INC., ANN ARBOR, MI:  
3,941,587, MULTIPLE CLASS, INT. CLS. 9, 41 AND 42.
- HUMBERTO RUBIO & ASSOCIATES, L.L.C, MIAMI, FL:  
3,940,285, PUB. 1-18-2011. INT. CL. 25.
- HUMMERT INTERNATIONAL, EARTH CITY, MO:  
3,942,358, MULTIPLE CLASS, INT. CLS. 31 AND 35.
- HUMMINGBIRD HIGHWAY LLC, SYRACUSE, NY:  
3,942,017, MULTIPLE CLASS, INT. CLS. 9 AND 41.
- HUNGER RELATED EVENTS, EDINA, MN:  
2,377,000, REN. 2-26-11. INT. CL. 36.
- HUNT, RUSSELL B., UPPER BLACK EDDY, PA, DBA RELIC-TRONICS:  
2,459,572, REN. 3-3-11. INT. CL. 37.
- HUNTER'S SPECIALTIES, INC., CEDAR RAPIDS, IA:  
3,941,976, INT. CL. 5.
- HUPP, DANIELLE, SAN FRANCISCO, CA:  
2,457,349, REN. 2-26-11. INT. CL. 37.
- HURST, ROBIN W, RICHMOND, VA:  
3,941,715, INT. CL. 41.
- HUSQVARNA AKTIEBOLAG, SWEDEN:  
3,754,886, COR. MULTIPLE CLASS, INT. CLS. 4 AND 7.
- HUTCH MEDIA, LLC, SANTA MONICA, CA:  
3,941,748, MULTIPLE CLASS, INT. CLS. 35 AND 41.
- HWA NAN FOOD INDUSTRIAL CO., LTD., NAN-TOU HSIEN, TAIWAN, LIAO, SHU-HSUN, TSAO TUN TOWN, NANTOU HSIEN, TAIWAN:  
1,617,781, REN. 2-26-11. INT. CL. 29.
- HWA RYUN JUGA CO., LTD., GYEONGGI-DO, REPUBLIC OF KOREA:  
3,941,197, INT. CL. 33.
- HY-KO PRODUCTS COMPANY, NORTHFIELD, OH:  
3,941,226, INT. CL. 9.
- HYBRID PROMOTIONS LLC, CYPRESS, CA:  
3,941,618, INT. CL. 25.
- HYDRO ONE LLC, AUGUSTA, GA:  
3,941,963, INT. CL. 5.
- HYDROCISION, INC., ANDOVER, MA:  
2,865,726, CANC. INT. CL. 10.
- HYI, COVINA, CA:  
2,482,665, REN. 2-25-11. INT. CL. 25.
- HYPERBRANCH MEDICAL TECHNOLOGY, INC., DURHAM, NC:  
3,941,950, INT. CL. 5.
- HYPERTHERM, INC., HANOVER, NH:  
2,377,494, CANC. INT. CL. 9.
- H2O FRONT LLC, WESTERLY, RI:  
2,865,437, CANC. INT. CL. 16.
- I AM PRODUCTS, LLC, WASHINGTON CROSSING, PA:  
3,942,246, INT. CL. 5.
- I SQUARE ENTERTAINMENT, LLC, PHILADELPHIA, PA:  
3,939,764, PUB. 1-18-2011. INT. CL. 41.
- I.M. STEIN, INC., MCHENRY, IL:  
3,941,564, INT. CL. 30.
- I-BEHAVIOR, INC., LOUISVILLE, CO:  
2,469,575, REN. 2-27-11. INT. CL. 35.
- I-DEV INTERNATIONAL, NEW YORK, NY:  
3,940,889, PUB. 1-18-2011. INT. CL. 44.
- I-ODOLOGY, INC., SCOTTSDALE, AZ:  
2,430,458, REN. 2-26-11. INT. CL. 42.
- I'M JDA LLC, BROOKLYN, NY:  
3,940,562, PUB. 1-18-2011. INT. CL. 35.
- IB INDUSTRIES, INC., PRIOR LAKE, MN:  
2,865,686, CANC. INT. CL. 35.
- IBEAM GROUP, LLC, CARMEL, CA:  
2,492,885, CANC. INT. CL. 14.
- IBERIA LINEAS AEREAS DE ESPANA SOCIEDAD ANONIMA OPERADORA, MADRID, SPAIN:  
908,843, REN. 2-25-11. U.S. CL. 105 (INT. CL. 39).
- IBEX HEALTHDATA SYSTEMS, INC., ROSEMONT, IL:  
2,864,585, CANC. MULTIPLE CLASS, INT. CLS. 9 AND 42.
- IBT CONSULTANTS INC., TINLEY PARK, IL:  
3,940,749, PUB. 1-18-2011. INT. CL. 11.
- IC&S, NIEUWEGEIN, NETHERLANDS:  
3,940,118, PUB. 1-18-2011. INT. CL. 42.
- ICARE INDUSTRIES, INC., ST. PETERSBURG, FL:  
2,792,858, CANC. INT. CL. 9.
- ICHIBANYA CO., LTD., JAPAN:  
3,939,901, PUB. 1-18-2011. MULTIPLE CLASS, INT. CLS. 35, 36 AND 43.
- ICQ HOLDING S.R.L., ITALY:  
3,939,883, PUB. 1-18-2011. MULTIPLE CLASS, INT. CLS. 28 AND 42.
- ID SOFTWARE LLC, MESQUITE, TX:  
3,941,007, INT. CL. 9.
- IDEAMAX CORPORATION, ALHAMBRA, CA:  
2,864,250, CANC. INT. CL. 35.
- IDENTITY MARKETING & PUBLIC RELATIONS, LLC, BINGHAM FARMS, MI:  
3,940,166, PUB. 1-18-2011. INT. CL. 35.
- IDETIX, INC., AUBURN HILLS, MI:  
2,865,244, CANC. INT. CL. 9.
- IDREES, GOWER, HOUSTON, TX:  
2,864,880, CANC. INT. CL. 43.
- IDT NETHERLANDS, B.V. (PUERTO RICO BRANCH), SAN JUAN, PUERTO RICO:  
2,864,874, CANC. INT. CL. 36.
- IFILM CORP., NEW YORK, NY:  
2,389,336, CANC. INT. CL. 41.
- IFILM CORP., HOLLYWOOD, CA:  
2,911,321, CANC. MULTIPLE CLASS, INT. CLS. 9 AND 16.
- IFILM CORP., NEW YORK, NY:  
3,642,048, CANC. INT. CL. 41.
- IFMI SARL, 75016 PARIS, FRANCE:  
2,864,016, CANC. MULTIPLE CLASS, INT. CLS. 3, 14, 18 AND 25.
- IFORMATA LLC, DAYTON, OH:  
3,941,293, MULTIPLE CLASS, INT. CLS. 38 AND 42.
- IFS FINANCIAL SERVICES, INC., CINCINNATI, OH:  
3,942,292, INT. CL. 36.
- IGAP SPA, COGOZZO DI VIADANA (MN), ITALY:  
3,940,012, PUB. 1-18-2011. INT. CL. 20.
- IGLOBE, INC., FRANKLIN, NH:  
3,941,061, INT. CL. 9.



IGNACIO DE LA PARRA Y DE LA PARRA, MARIO, PUEBLA, MEXICO:  
3,939,836, PUB. 1-18-2011. INT. CL. 29.

IGT, RENO, NV:  
3,940,951, PUB. 1-18-2011. INT. CL. 9.  
3,941,030, INT. CL. 9.  
3,941,043, INT. CL. 9.  
3,941,157, INT. CL. 9.

ILL DIALECT, INC., ARDMORE, PA:  
3,941,346, INT. CL. 45.

ILLINOIS AUTO ELECTRIC, AURORA, IL:  
3,941,441, MULTIPLE CLASS, INT. CLS. 12, 25 AND 37.

ILLINOIS TOOL WORKS INC, GLENVIEW, IL, DOVER CORPORATION, NEW YORK, NY:  
1,172,971. REN. 2-25-11. INT. CL. 9.

ILLINOIS TOOL WORKS INC., GLENVIEW, IL:  
1,635,948. REN. 2-28-11. INT. CL. 5.  
2,522,184. REN. 3-3-11. INT. CL. 3.  
2,525,030. REN. 2-26-11. INT. CL. 35.

IM READY-MADE LLC, NEW YORK, NY:  
3,942,020, INT. CL. 35.

IMAGINE IMAGING, L.L.C., CHICAGO, IL:  
2,864,366, CANC. INT. CL. 40.

IMAGING SOLUTIONS GROUP OF NY, INC., FAIRPORT, NY:  
3,939,695, PUB. 1-18-2011. INT. CL. 9.

IMAGIWARE, INC., MADISON, WI:  
2,864,510, CANC. MULTIPLE CLASS, INT. CLS. 9 AND 42.

IMAGYN IP, LLC, MADISON, WI:  
3,940,232, PUB. 1-18-2011. INT. CL. 44.

IMASTAR CORPORATION, WEST HOLLYWOOD, CA:  
3,941,369, INT. CL. 3.

IMBRIUM SYSTEMS CORPORATION, TORONTO, ONTARIO, CANADA:  
3,939,411, PUB. 1-18-2011. INT. CL. 11.

IMERGENT, INC., OREM, UT:  
3,940,570, PUB. 1-18-2011. MULTIPLE CLASS, INT. CLS. 38 AND 42.  
3,940,879, PUB. 1-18-2011. MULTIPLE CLASS, INT. CLS. 38 AND 42.

IMMEDIATEFX, LLC, MONROE, CT:  
2,864,407, CANC. INT. CL. 9.

IMMUCELL CORPORATION, PORTLAND, ME:  
2,432,904. REN. 3-3-11. INT. CL. 5.

IMPACT PERSONAL SAFETY, INC., LOS ANGELES, CA:  
3,940,126, PUB. 1-18-2011. INT. CL. 41.

IMPACT PRODUCTIONS, INC., DENVER, CO:  
2,496,526. REN. 2-26-11. MULTIPLE CLASS, INT. CLS. 35 AND 41.

IMPACT TECHNOLOGIES, LLC, ROCHESTER, NY:  
3,941,929, INT. CL. 9.

IMPACT WEAPONS COMPONENTS, LLC, TIMNATH, CO:  
3,940,087, PUB. 1-18-2011. INT. CL. 13.

IMPAX HEALTHPRIME, INC., EL DORADO HILLS, CA:  
2,367,535, CANC. INT. CL. 5.

IMPLUS FOOTCARE, LLC, MORRISVILLE, NC:  
3,939,787, PUB. 7-27-2010. INT. CL. 28.

IMS TRADING CORPORATION, WOOD-RIDGE, NJ:  
3,940,910, PUB. 1-18-2011. INT. CL. 31.

IN TOUCH MINISTRIES, INC., ATLANTA, GA:  
3,939,549, PUB. 1-18-2011. INT. CL. 45.  
3,939,550, PUB. 1-18-2011. INT. CL. 45.

IN YA FACE RECORDS, INC., SAN JOSE, CA:  
3,942,076, MULTIPLE CLASS, INT. CLS. 9 AND 41.

INAVISIS, INC., SAN DIEGO, CA:  
2,538,026. REN. 3-2-11. MULTIPLE CLASS, INT. CLS. 36 AND 42.  
2,538,027. REN. 3-2-11. MULTIPLE CLASS, INT. CLS. 36 AND 42.

INCA DIGITAL PRINTERS LIMITED, CAMBRIDGE, UNITED KINGDOM:  
3,940,361, PUB. 1-18-2011. INT. CL. 9.

INCOGNITO INCORPORATED, MARYSVILLE, WA:  
3,940,681, PUB. 1-18-2011. INT. CL. 25.

INDEPENDENT HEALTHCARE PROPERTIES, LLC, GEORGETOWN, TN:  
2,541,893. REN. 2-25-11. MULTIPLE CLASS, INT. CLS. 36 AND 37.

INDEPENDENT LIVING SYSTEMS, LLC, MIAMI, FL:  
3,939,692, PUB. 1-18-2011. INT. CL. 39.

INDIAN VALLEY LACROSSE CO., HARLEYSVILLE, PA:  
3,940,601, PUB. 1-18-2011. INT. CL. 28.

INDIGO OLIVE SOFTWARE, INC., LOUISVILLE, KY:  
2,864,983, CANC. MULTIPLE CLASS, INT. CLS. 9 AND 42.

INDULGENT FOODS, LLC, CLEARFIELD, UT:  
3,939,590, PUB. 1-18-2011. INT. CL. 30.

INDUSTRIA ADRIATICA CONFEZIONI S.P.A., CHIETI, ITALY:  
2,428,994. REN. 2-26-11. INT. CL. 25.

INEOS FLUOR HOLDINGS LIMITED, CHESHIRE WA7 4QF, UNITED KINGDOM:  
2,864,848, CANC. MULTIPLE CLASS, INT. CLS. 1, 3 AND 40.

INETCO SYSTEMS LIMITED, BURNABY, B.C., CANADA:  
3,939,421, PUB. 1-18-2011. MULTIPLE CLASS, INT. CLS. 9 AND 42.  
3,939,422, PUB. 1-18-2011. MULTIPLE CLASS, INT. CLS. 9 AND 42.

INFANTINO, LLC, SAN DIEGO, CA:  
3,941,729, INT. CL. 18.

INFINICYTE, LLC, LOS ANGELES, CA:  
3,941,554, MULTIPLE CLASS, INT. CLS. 9 AND 42.

INFINITY WINERY CORPORATION, NEWPORT BEACH, CA, DBA CALIFORNIA INFINITY WINERY:  
3,942,177, INT. CL. 33.  
3,942,268, INT. CL. 33.

INFLECTION LLC, PALO ALTO, CA:  
3,940,666, PUB. 1-18-2011. INT. CL. 42.

INFO MARKETING INC., MIAMI BEACH, FL:  
3,942,275, INT. CL. 41.

INFOGROUP INC., OMAHA, NE:  
3,940,151, PUB. 1-18-2011. INT. CL. 38.  
3,940,152, PUB. 1-18-2011. INT. CL. 38.

INFOMEDICS, INC., WOBURN, MA:  
2,864,882, CANC. INT. CL. 35.

INFOR GLOBAL SOLUTIONS (MASSACHUSETTS), INC., ATLANTA, GA:  
2,865,011, CANC. INT. CL. 9.

INFORMATION DECISION TECHNOLOGIES LLC, BEDFORD, NH:  
2,865,488, CANC. INT. CL. 9.

INFORMATION EXPRESS, INC., MENLO PARK, CA:  
2,426,645. REN. 2-25-11. INT. CL. 38.

INFORMATION SYSTEMS AUDIT AND CONTROL ASSOCIATION, ROLLING MEADOWS, IL:  
2,431,581. REN. 3-2-11. INT. CL. 16.  
2,431,581, AM. INT. CL. 16.

INFORMATIVE DESIGN GROUP, INC., CHANTILLY, VA, DBA THE HISTORY FACTORY:  
3,941,324, MULTIPLE CLASS, INT. CLS. 9 AND 42.  
3,941,325, MULTIPLE CLASS, INT. CLS. 9 AND 42.  
3,941,326, MULTIPLE CLASS, INT. CLS. 9 AND 42.

INFORMATIVE DESIGN GROUP, INC., DBA THE HISTORY FACTORY, CHANTILLY, VA:  
3,941,284, INT. CL. 35.

INFUSE ATHLETICS LLC, PORT SAINT LUCIE, FL, DBA INFUSE ATHLETICS LLC:  
3,941,857, INT. CL. 25.

INGEAR FASHIONS, INC., MIAMI, FL:  
3,940,832, PUB. 1-18-2011. INT. CL. 25.

INGENIUM PHARMACEUTICALS AG, 82152 MARTINSRIED, FED REP GERMANY:  
2,865,545, CANC. MULTIPLE CLASS, INT. CLS. 42 AND 44.

INGERSOLL-RAND COMPANY, WOODCLIFF LAKE, NJ:  
898,238. REN. 3-2-11. U.S. CL. 23 (INT. CL. 7).

INGRAM ENTERPRISES, INC., SPRINGFIELD, MO:  
3,941,607, INT. CL. 13.

INGRAM, JR., JOE WILLIAM, CHARLOTTE, NC:  
2,864,441, CANC. INT. CL. 42.

INN, MELINDA, SAN FRANCISCO, CA:  
3,942,202, INT. CL. 45.

INNERLINK, INC., LANCASTER, PA:  
3,939,722, PUB. 1-18-2011. INT. CL. 41.

- INNOVATION PHILADELPHIA INC., PHILADELPHIA, PA:  
2,865,151, CANC. INT. CL. 35.
- INNOVATION VENTURES, LLC, FARMINGTON HILLS, MI:  
3,940,928, PUB. 1-18-2011. MULTIPLE CLASS, INT. CLS. 5 AND 32.  
3,940,929, PUB. 1-18-2011. MULTIPLE CLASS, INT. CLS. 5 AND 32.  
3,940,946, PUB. 1-18-2011. MULTIPLE CLASS, INT. CLS. 5 AND 32.
- INNOVATIVE GAMING CORPORATION OF AMERICA, RENO, NV:  
2,236,060, CANC. INT. CL. 41.
- INNOVATIVE TECHNOLOGIES, BRISTOL, VA:  
2,506,293, REN. 3-2-11. INT. CL. 5.
- INOTEC INNOVATIVE BUSINESS TECHNOLOGIES, INC., LOUISVILLE, CO:  
2,368,130, CANC. INT. CL. 35.
- INOUT SOFTWARE, LLC, ALDIE, VA:  
3,940,541, PUB. 1-18-2011. MULTIPLE CLASS, INT. CLS. 41 AND 42.
- INOVOBIOLOGIC INC., CALGARY, AB, CANADA:  
3,939,800, PUB. 1-18-2011. INT. CL. 5.
- INSECT CONTROL & RESEARCH, INC., BALTIMORE, MD:  
2,368,498, CANC. INT. CL. 42.
- INSIDE MOVES LLC, ORLANDO, FL:  
2,864,603, CANC. INT. CL. 42.
- INSIGHT LIGHTING, INC., RIO RANCHO, NM:  
3,941,390, MULTIPLE CLASS, INT. CLS. 9 AND 11.
- INSPECT USA, INC., CHEYENNE, WY:  
2,496,383, REN. 3-3-11. INT. CL. 42.
- INSTITUT DE SELECTION ANIMALE - ISA, 22000 SAINT-BRIEUC, FRANCE:  
3,939,501, PUB. 1-18-2011. INT. CL. 31.
- INSTITUT FUR TELEMATIK E.V., TRIER, FED REP GERMANY:  
2,864,036, CANC. MULTIPLE CLASS, INT. CLS. 9, 16, 35, 38 AND 42.
- INSULGLASS, INC., MIAMI, FL:  
2,865,088, CANC. INT. CL. 17.
- INTEGRAN TECHNOLOGIES INC., TORONTO, ONTARIO, CANADA:  
2,864,160, CANC. MULTIPLE CLASS, INT. CLS. 2, 6, 37 AND 40.
- INTEGRATED TECHNOLOGY SYSTEMS, INC., WINDER, GA:  
3,940,834, PUB. 1-18-2011. INT. CL. 9.  
3,940,835, PUB. 1-18-2011. INT. CL. 9.
- INTEGRITY MEDIA, INC., MOBILE, AL:  
3,019,864, CANC. INT. CL. 16.
- INTERACTIVE INTELLIGENCE, INC., INDIANAPOLIS, IN:  
3,939,603, PUB. 1-18-2011. INT. CL. 9.
- INTERCO INCORPORATED, ST. LOUIS, MO TO MOVITZ, MILTON, ST. LOUIS, MO:  
1,140,870, CANC. INT. CL. 25.
- INTERGRATED IT SOLUTIONS, INC., WALTHAM, MA:  
2,456,675, REN. 2-26-11. INT. CL. 9.
- INTERJACENT TECHNOLOGY SYSTEMS, INC., CORRALITOS, CA:  
3,941,795, INT. CL. 9.  
3,941,796, INT. CL. 42.
- INTERMARKETING EXPRESS L.L.C., MIAMI, FL:  
2,864,143, CANC. INT. CL. 35.
- INTERMOUNTAIN HEALTH CARE, INC., SALT LAKE CITY, UT:  
2,865,117, CANC. INT. CL. 41.
- INTERNATIONAL ASSOCIATION OF LIONS CLUBS, THE, OAK BROOK, IL:  
908,283, REN. 2-25-11. U.S. CL. 200.
- INTERNATIONAL BAY CLUBS, INCORPORATION, NEWPORT BEACH, CA:  
2,431,243, REN. 3-1-11. MULTIPLE CLASS, INT. CLS. 16, 24, 25 AND 42.
- INTERNATIONAL BEVERAGE PACKAGING ASSOCIATION, HENDERSON, NV:  
2,864,226, CANC. U.S. CL. 200.
- INTERNATIONAL BULLION & METAL BROKERS (USA) INC., SUNRISE, FL:  
3,941,948, INT. CL. 14.
- INTERNATIONAL BUSINESS MACHINES CORPORATION, ARMONK, NY, AKA IBM CORPORATION:  
2,863,996, CANC. MULTIPLE CLASS, INT. CLS. 9 AND 42.
- INTERNATIONAL BUSINESS MACHINES CORPORATION, UNITED STATES:  
3,940,003, PUB. 1-18-2011. MULTIPLE CLASS, INT. CLS. 9, 16 AND 42.
- INTERNATIONAL BUSINESS MACHINES CORPORATION, ARMONK, NY:  
3,942,030, INT. CL. 42.
- INTERNATIONAL CARWASH ASSOCIATION, INC, CHICAGO, IL:  
2,470,878, REN. 3-1-11. INT. CL. 35.
- INTERNATIONAL CONSTRUCTION PRODUCTS RESEARCH, INC., FAIRFIELD, CT, NOMIX CORPORATION, FAIRFIELD, CT:  
1,646,862, REN. 3-2-11. INT. CL. 19.
- INTERNATIONAL CRUISE LIQUOR & TOBACCO, LLC, MIAMI, FL:  
2,865,541, CANC. INT. CL. 34.
- INTERNATIONAL EROSION CONTROL ASSOCIATION, DENVER, CO:  
3,941,127, INT. CL. 42.
- INTERNATIONAL FLAVORS & FRAGRANCES INC., NEW YORK, NY:  
2,368,272, CANC. MULTIPLE CLASS, INT. CLS. 1 AND 3.  
2,864,562, CANC. INT. CL. 16.  
2,864,570, CANC. INT. CL. 35.
- INTERNATIONAL IMAGING, INC., WINSTON SALEM, NC, DBA DESIGN FACTORY INTERNATIONAL:  
2,368,006, CANC. INT. CL. 42.
- INTERNATIONAL LEARNING TRUST, HUNTSVILLE, AL:  
2,368,868, CANC. INT. CL. 41.
- INTERNATIONAL LEARNING TRUST, NEW PORT RICHEY, FL:  
2,431,087, REN. 3-3-11. INT. CL. 41.
- INTERNATIONAL LEGAL AND BUSINESS SERVICES GROUP, SCHAUMBURG, IL:  
3,940,320, PUB. 1-18-2011. INT. CL. 45.
- INTERNATIONAL MARKET BRANDS, INC., ERIE, PA:  
2,434,670, REN. 3-3-11. INT. CL. 29.
- INTERNATIONAL PAYMENTS FRAMEWORK, LLC, HERNDON, VA:  
3,942,027, MULTIPLE CLASS, INT. CLS. 16 AND 35.
- INTERNATIONAL PREMATURE OVARIAN FAILURE ASSOCIATION, INC, ALEXANDRIA, VA:  
3,941,408, INT. CL. 45.
- INTERNET BRANDS, INC., EL SEGUNDO, CA:  
2,478,891, REN. 2-25-11. MULTIPLE CLASS, INT. CLS. 35 AND 39.
- INTERTREND, LTD., CAUSEWAY BAY, HONG KONG:  
1,634,760, REN. 2-28-11. INT. CL. 12.
- INTERVET INC., ROSELAND, NJ:  
3,941,822, INT. CL. 5.
- INTERVET INTERNATIONAL B.V., BOXMEER, NETHERLANDS:  
2,864,806, CANC. INT. CL. 5.
- INTERVET, INC., SUMMIT, NJ, AMBICO, INC., DALLAS CENTER, IA:  
1,635,928, REN. 2-26-11. INT. CL. 5.
- INTUNE CORPORATION, VENTURA, CA:  
2,865,717, CANC. INT. CL. 9.
- INVENTIO AG, HERGISWIL, SWITZERLAND, AUFGUGE-UND ELEKTROMOTORENFABRIK SCHINDLER AG, 6030 EBIKON, SWITZERLAND:  
1,172,010, REN. 3-3-11. MULTIPLE CLASS, INT. CLS. 7 AND 9.
- INVERSORA LUMIRT S.A., MONTEVIDEO, URUGUAY:  
3,941,415, INT. CL. 3.
- INVESTMENT PROFESSIONALS, INC., SAN ANTONIO, TX:  
2,755,703, CANC. INT. CL. 36.
- INVICTA LAW GROUP PLLC, SEATTLE, WA:  
2,512,201, REN. 2-26-11. INT. CL. 42.

INVICTA WATCH COMPANY OF AMERICA, INC., HOLLYWOOD, FL:  
3,941,014, INT. CL. 14.

IPG INTERNATIONAL PRODUCTS GROUP INC, DORAL, FL:  
3,941,616, MULTIPLE CLASS, INT. CLS. 9, 18 AND 25.

IPOWERWEB.COM, INC., SANTA MONICA, CA:  
2,864,372, CANC. INT. CL. 42.

IPSEN BIOPHARM LIMITED, WREXHAM, UNITED KINGDOM:  
3,941,865, INT. CL. 5.

IQBOT INFORMATION SYSTEMS GMBH, A-4600 WELS, AUSTRIA:  
2,863,934, CANC. INT. CL. 38.

IRONMIND ENTERPRISES, INC., NEVADA CITY,, CA:  
1,637,236, REN. 3-2-11, INT. CL. 42.

IRWIN BANK & TRUST COMPANY, IRWIN, PA:  
2,865,119, CANC. INT. CL. 36.

IRWIN INDUSTRIAL TOOL COMPANY, ATLANTA, GA:  
2,435,902, REN. 2-28-11, INT. CL. 7.

IS THAT ODD, INC., KIRKLAND, WA:  
3,941,990, MULTIPLE CLASS, INT. CLS. 35 AND 38.  
3,941,991, MULTIPLE CLASS, INT. CLS. 35 AND 38.

ISA CORPORATION, SALEM, OR:  
3,942,293, INT. CL. 17.

ISAACS, DAVID, BROOKLYN, NY:  
3,941,076, MULTIPLE CLASS, INT. CLS. 16 AND 25.

ISATORI TECHNOLOGIES, LLC, GOLDEN, CO:  
3,941,041, INT. CL. 5.

ISCHOLAR, INC., LINDENHURST, NY:  
3,940,563, PUB. 1-18-2011, INT. CL. 16.  
3,940,567, PUB. 1-18-2011, INT. CL. 16.

ISENCO, HUNTINGTON BEACH, CA:  
2,864,981, CANC. INT. CL. 41.

ISKCON GOVERNING BODY COMMISSION, PITTSBURGH, PA:  
3,939,659, PUB. 1-18-2011, MULTIPLE CLASS, U.S. CL. 200 INT. CLS. 41 AND 45.

ISUN VISIONS, LLC, RIDGWAY, CO:  
3,940,549, PUB. 1-18-2011, INT. CL. 3.

ITA PARTNERS, INC., PHILADELPHIA, PA:  
3,941,494, MULTIPLE CLASS, INT. CLS. 35, 42, 44 AND 45.

ITALGEL INCORPORATED, NORTH HOLLYWOOD, CA:  
2,864,303, CANC. INT. CL. 11.

ITALGELATINE S.P.A., SANTA VITTORIA D'ALBA (CN), ITALY:  
3,939,996, PUB. 1-18-2011, INT. CL. 33.

ITON CORPORATION,, MISSISSAUGA, ONTARIO, CANADA:  
3,941,705, INT. CL. 42.

ITT CORPORATION, WHITE PLAINS, NY, WATER EQUIPMENT TECHNOLOGIES, INC., WEST PALM BEACH, FL:  
1,634,368, REN. 2-26-11, MULTIPLE CLASS, INT. CLS. 37 AND 40.

ITT CORPORATION, WHITE PLAINS, NY:  
2,865,744, CANC. INT. CL. 9.

IVIVI TECHNOLOGIES, INC., SAN FRANCISCO, CA:  
3,854,617, COR. INT. CL. 10.

IVOCLAR VIVADENT, INC., AMHERST, NY:  
3,940,084, PUB. 1-18-2011, INT. CL. 5.

IVY PURCHASE, LLC, ATLANTA, GA:  
2,369,283, CANC. INT. CL. 9.

IWANICKI, TIMOTHY B., PERU, IL, DBA DRUTHERS BEVERAGE COMPANY:  
2,430,301, REN. 2-25-11, INT. CL. 32.

J & L LOBMEYR GESELLSCHAFT MBH, VIENNA, AUSTRIA, RATH, HANS HARALD, VIENNA, AUSTRIA, DBA J. & L. LOBMEYR, DBA J. & L. LOBMEYR:  
704,637, REN. 3-3-11, U.S. CL. 33 (INT. CL. 21).

J CONSORTIUM, INC., CUPERTINO, CA:  
2,865,766, CANC. INT. CL. 16.

J G INNOVATIONS, INC., JANESVILLE, WI:  
3,939,628, PUB. 1-18-2011, INT. CL. 6.

J M OIL COMPANY, ST. CLOUD, MN:  
2,369,334, CANC. INT. CL. 35.

J VINEYARDS & WINERY, L.P., HEALDSBURG, CA:  
3,942,089, INT. CL. 33.

J. & P. COATS, LIMITED, GLASGOW, UNITED KINGDOM:  
81,462, REN. 2-28-11, U.S. CL. 7 (INT. CL. 22).

J. & P. COATS, LIMITED, GLASGOW G2 5PA, SCOTLAND:  
3,941,048, INT. CL. 26.

J. ROY PARCELS ASSOCIATES, LLC, COLUMBUS, UNITED STATES:  
1,636,284, REN. 3-3-11, INT. CL. 35.

J. S. VIG CONSTRUCTION CO., TAYLOR, MI:  
3,939,477, PUB. 1-18-2011, INT. CL. 37.  
3,939,478, PUB. 1-18-2011, INT. CL. 37.  
3,939,479, PUB. 1-18-2011, INT. CL. 37.

J. WAGNER GMBH, FED REP GERMANY:  
3,939,943, PUB. 1-18-2011, MULTIPLE CLASS, INT. CLS. 1, 2 AND 7.

J.G. WENTWORTH S.S.C. LIMITED PARTNERSHIP, BRYN MAWR, PA:  
3,940,887, PUB. 1-18-2011, INT. CL. 36.

J&J SNACK FOODS CORP., PENNSAUKEN, NJ, TROTTER SOFT PRETZELS, INC., HATFIELD, PA:  
1,147,776, REN. 3-2-11, INT. CL. 30.

JACK ROGERS HOLDING COMPANY LLC, NEW YORK, NY:  
3,942,045, INT. CL. 35.

JACKSON STATE UNIVERSITY, JACKSON, MS:  
3,939,355, PUB. 1-18-2011, MULTIPLE CLASS, INT. CLS. 24, 27 AND 32.

JACKSONVILLE BANCORP, INC., JACKSONVILLE, FL:  
2,459,122, REN. 2-26-11, INT. CL. 36.

JAFFA, DAVID, LONDON WC2B 5HA, UNITED KINGDOM:  
3,941,418, MULTIPLE CLASS, INT. CLS. 41 AND 42.

JAGLOWSKI, THOMAS J., DERRY, NH:  
2,864,432, CANC. INT. CL. 42.

JAGUAR CARS LIMITED, COVENTRY, UNITED KINGDOM, ZOLKIND & SONS, INC., OCEANSIDE, NY:  
1,166,342, REN. 3-3-11, INT. CL. 9.

JAGUAR CARS LIMITED, COVENTRY, UNITED KINGDOM:  
3,940,956, PUB. 1-18-2011, INT. CL. 12.

JAKKS PACIFIC, INC., MALIBU, CA:  
2,373,935, REN. 2-25-11, INT. CL. 16.  
2,864,929, CANC. INT. CL. 28.

JAMALL ADAMS, QUEENS, NY:  
3,942,138, INT. CL. 25.

JAMES C. HOWARD, FORT LAUDERDALE, FL:  
3,942,371, MULTIPLE CLASS, INT. CLS. 9, 35 AND 36.

JAMES CHEN, ROWLAND HEIGHTS, CA:  
3,941,392, INT. CL. 21.

JAMES DE GIVENCHY, INC., NEW YORK, NY:  
3,941,029, MULTIPLE CLASS, INT. CLS. 16 AND 18.

JAMES H. BATTLE AND JOSEPH S. EDWARDS, NEWPORT NEWS, VA, DBA B&E APPAREL:  
2,865,584, CANC. INT. CL. 25.

JAMES H. JONES,, LOS ANGELES, CA:  
3,939,386, PUB. 1-18-2011, INT. CL. 42.

JAMES V NOVAK, UNITED KINGDOM:  
3,939,884, PUB. 1-18-2011, INT. CL. 12.

JAMESTOWN, L.P., ATLANTA, GA:  
2,522,550, REN. 3-2-11, MULTIPLE CLASS, INT. CLS. 36 AND 37.  
2,522,552, REN. 3-2-11, MULTIPLE CLASS, INT. CLS. 36 AND 37.

JANINE WARNER, LOS ANGELES, CA:  
3,942,363, MULTIPLE CLASS, INT. CLS. 35, 41 AND 42.

JAPAN POLYPROPYLENE CORPORATION, TOKYO, JAPAN, MITSUBISHI CHEMICAL INDUSTRIES LIMITED, CHIYODA-KU, TOKYO, JAPAN:  
909,848, REN. 3-3-11, U.S. CL. 1 (INT. CL. 1).

JAPAN X LLC, CHATSWORTH, CA:  
2,865,812, CANC. INT. CL. 9.

JARROW FORMULAS, INC., LOS ANGELES, CA:  
2,445,383, REN. 2-28-11, INT. CL. 5.

JASON & JEAN PRODUCTS INC., CORONA, NY:  
3,941,003, INT. CL. 3.

JASPER, JOSEPHINE, CLIFTON, NJ:  
2,528,495, CANC. INT. CL. 42.

JAST PARTNERS, LLC, DALLAS, TX:  
3,940,259, PUB. 1-18-2011, INT. CL. 43.

- JAVA CITY, INC., SACRAMENTO, CA:  
3,939,648, PUB. 1-18-2011. MULTIPLE CLASS, INT. CLS.  
21 AND 43.
- JAX INC., MENOMONEE FALLS, WI, FORMERLY  
BHENKE LUBRICANTS, INC.:  
3,940,920, PUB. 1-18-2011. INT. CL. 4.
- JAX INC., MENOMONEE FALLS, WI, FORMERLY  
BHENKE LUBRICANTS, INC.:  
3,940,922, PUB. 1-18-2011. INT. CL. 4.
- JAY STRONGWATER, INC., NEW YORK, NY:  
1,669,374. REN. 3-2-11. INT. CL. 14.
- JB INTELLECTUAL PROPERTY, LLC, PALM BEACH, FL:  
3,939,868, PUB. 1-18-2011. INT. CL. 25.  
3,939,869, PUB. 1-18-2011. INT. CL. 9.
- JBR ENVIRONMENTAL CONSULTANTS, INC., SANDY,  
UT:  
3,939,806, PUB. 1-18-2011. MULTIPLE CLASS, INT. CLS.  
37 AND 40.  
3,939,807, PUB. 1-18-2011. INT. CL. 45.
- JDC TRUST DATED NOVEMBER 16, 2009, SCOTTSDALE,  
AZ:  
2,367,533, CANC. INT. CL. 12.
- JEAN MICHELLE KEEP IT OFF - WEIGHT LOSS, PORT  
ORCHARD, WA:  
3,939,846, PUB. 1-18-2011. INT. CL. 5.
- JEANA FLEITZ, LOUISVILLE, KY, DBA X-RAY LADY:  
3,940,592, PUB. 1-18-2011. INT. CL. 41.
- JEANINE HAYS, SAN FRANCISCO, CA:  
3,941,456, INT. CL. 20.
- JEFF SMITH, ALPHARETTA, GA:  
3,942,134, INT. CL. 19.
- JEFFREY COURT, INC., ANAHEIM HILLS, CA:  
3,942,316, INT. CL. 19.
- JELLY BELLY CANDY COMPANY, FAIRFIELD, CA:  
3,942,114, INT. CL. 21.
- JENKINS, MARK E., ALISO VIEJO, CA, DBA MARRIAGE  
911:  
3,941,490, INT. CL. 45.
- JENNIFER J HARTMAN, PORT ST LUCIE, FL, DBA  
KENJENS LLC:  
3,942,469, INT. CL. 25.
- JEPPESEN SANDERSON, INC., ENGLEWOOD, CO:  
2,368,378, CANC. INT. CL. 9.  
2,438,256. REN. 3-2-11. INT. CL. 16.
- JERANKO, KAREN D., WESTMINSTER, CO:  
3,941,042, INT. CL. 14.
- JEREMY COWAN, SAN FRANCISCO, CA:  
3,941,407, INT. CL. 40.
- JERRY HICKS, BOERNE, TX AND ESTHER HICKS,  
BOERNE, TX:  
3,894,472, COR. INT. CL. 9.
- JERRY JONES GUITARS, NASHVILLE, TN:  
2,432,893. REN. 2-26-11. INT. CL. 15.
- JERRY LANIER, LOS ANGELES, CA:  
3,941,092, INT. CL. 41.
- JERUSALEM SANDALS, SHERMAN OAKS, CA:  
3,942,448, INT. CL. 25.
- JET WAY INFORMATION CO., LTD., CHUNG HO CITY,  
TAIWAN:  
2,864,424, CANC. INT. CL. 9.
- JEWELS AND DIAMONDS ENTERPRISES, ST. PETE  
BEACH, FL:  
2,444,355. REN. 2-26-11. INT. CL. 35.
- JEWELS AND DIAMONDS ENTERPRISES, HOMOSASSA,  
FL:  
2,479,547. REN. 2-26-11. INT. CL. 14.
- JEWISH ADVOCATE PUBLISHING CORP., BOSTON, MA:  
1,676,769. REN. 3-3-11. INT. CL. 16.
- JEWISH BROADCASTING NETWORK CORPORATION,  
CHICAGO, IL:  
2,865,798, CANC. INT. CL. 16.
- JEWISH RENAISSANCE MEDIA, LLC, SOUTHFIELD, MI:  
3,314,892, CANC. INT. CL. 16.
- JIANGSU EVERSOLAR NEW ENERGY CO., LTD., SUZ-  
HOU, JIANGSU, CHINA:  
3,940,290, PUB. 1-18-2011. INT. CL. 4.  
3,940,291, PUB. 1-18-2011. INT. CL. 9.
- JIFFY LUBE INTERNATIONAL, INC, HOUSTON, TX:  
3,941,103, INT. CL. 41.
- JIGZAW, INC., CHICAGO, IL:  
2,864,607, CANC. INT. CL. 42.
- JINAN DIOR GLASS PRODUCT CO., LTD., SHANDONG  
PROVINCE, CHINA:  
3,940,683, PUB. 1-18-2011. INT. CL. 21.
- JIWANI MADE TO MEASURE, INC., ATLANTA, GA:  
2,440,192. REN. 2-25-11. INT. CL. 40.
- JJ COMMUNICATIONS, INC., ENGLEWOOD, NJ:  
2,864,769, CANC. INT. CL. 9.
- JL POWELL LLC, THREE OAKS, MI:  
3,940,149, PUB. 1-18-2011. INT. CL. 25.
- JOBERVE LIMITED, TIPTREE, ESSEX, UNITED KING-  
DOM:  
2,480,300. REN. 2-26-11. INT. CL. 35.
- JOHANNES F. COY, 64853 OTZBERG, FED REP GERMANY:  
3,939,947, PUB. 1-18-2011. MULTIPLE CLASS, INT. CLS.  
5, 29, 30 AND 32.
- JOHN J. ZELENKA, CHESTNUT RIDGE, NY, DBA STEREO  
REALIST:  
3,940,298, PUB. 1-18-2011. INT. CL. 9.
- JOHN PAUL MITCHELL SYSTEMS, SAUGUS, CA:  
3,942,362, INT. CL. 3.
- JOHN RICH & SONS INVESTMENT HOLDING COMPANY,  
WILMINGTON, DE:  
2,927,074, CANC. INT. CL. 24.
- JOHN WILEY & SONS, INC., HOBOKEN, NJ:  
2,863,908, CANC. INT. CL. 16.
- JOHNSON & JOHNSON, NEW BRUNSWICK, NJ:  
2,864,188, CANC. INT. CL. 10.  
3,939,493, PUB. 11-24-2009. INT. CL. 3.  
3,939,508, PUB. 1-18-2011. INT. CL. 44.  
3,940,980, INT. CL. 41.
- JOHNSON HEALTH TECH NORTH AMERICA, INC., COT-  
TAGE GROVE, WI:  
3,939,696, PUB. 1-18-2011. INT. CL. 10.
- JOHNSON OUTDOORS MARINE ELECTRONICS, INC.,  
EUFAULA, AL:  
3,941,443, INT. CL. 9.
- JOHNSON PUBLISHING COMPANY, INC., CHICAGO, IL:  
3,941,008, INT. CL. 41.
- JOHNSON, CHRISTINE JOAN, RIMINI, ITALY:  
3,939,591, PUB. 1-18-2011. MULTIPLE CLASS, INT. CLS.  
9, 25 AND 41.
- JOHNSON, JIMMY, SHEFFIELD, AL:  
2,785,747, CANC. INT. CL. 9.
- JOHNSON, LINDA LEE, NEW YORK, NY:  
1,642,742. REN. 2-28-11. INT. CL. 14.
- JOHNSON, ODYSSEUS, WILMETTE, IL:  
3,941,579, MULTIPLE CLASS, INT. CLS. 25 AND 41.
- JOHNSON, STANLEY A., STURGEON BAY, WI:  
3,941,702, INT. CL. 21.
- JOICO LABORATORIES, INC., CITY OF INDUSTRY, CA:  
2,553,841, CANC. INT. CL. 3.
- JOINGO, INCLINE VILLAGE, NV:  
3,940,469, PUB. 1-18-2011. INT. CL. 42.
- JOINT COMMISSION ON ALLIED HEALTH PERSONNEL  
IN OPHTHALMOLOGY, WOODBURY, MN, DBA JCAH-  
PO:  
3,940,489, PUB. 1-18-2011. INT. CL. 41.
- JOINT RESTORATION FOUNDATION, INC., CENTEN-  
NIAL, CO:  
3,941,562, INT. CL. 5.
- JOMOWAG LLC, SNOQUALMIE, WA:  
3,941,811, INT. CL. 25.
- JONES-BLAIR COMPANY, DALLAS, TX:  
3,941,546, INT. CL. 2.
- JONES-HAMILTON CO., WALBRIDGE, OH:  
2,433,764. REN. 3-1-11. INT. CL. 1.
- JONES, GARY S., VILLANOVA, PA:  
2,458,567. REN. 3-3-11. INT. CL. 42.
- JONES, JERRY, NASHVILLE, TN:  
2,434,079. REN. 2-26-11. INT. CL. 15.  
2,434,357. REN. 2-26-11. INT. CL. 15.
- JONES, TYRONE D., BALTIMORE, MD:  
3,941,792, INT. CL. 30.

JONESHEIRS, INC., ATLANTA, GA:  
3,904,150, AM. INT. CL. 25.

JOODAYOH, INC., NEW YORK, NY:  
3,939,475, PUB. 4-6-2010. INT. CL. 35.

JOSE MARIA DA FONSECA, SUCESSORES VINHOS, S.A.,  
2925-901 AZEITAO, SETUBAL, PORTUGAL:  
2,865,006, CANC. INT. CL. 33.

JOSH SUHRE DESIGN, LLC, CINCINNATI, OH:  
3,941,727, MULTIPLE CLASS, INT. CLS. 18 AND 25.

JOTUN A/S, 3209 SANDEFJORD, NORWAY:  
2,864,863, CANC. MULTIPLE CLASS, INT. CLS. 1 AND 2.

JOURNAL SENTINEL INC., MILWAUKEE, WI:  
3,942,388, MULTIPLE CLASS, INT. CLS. 35, 38 AND 41.

JOURNEY, INC., WINDSOR, CO:  
2,422,156, REN. 2-28-11. INT. CL. 21.

JOYCE MEDIA, INC., ROSAMOND, CA:  
2,518,985, CANC. MULTIPLE CLASS, INT. CLS. 9, 14, 26,  
28 AND 41.

JOYOUNG COMPANY LIMITED, SHANDONG PROVINCE,  
CHINA:  
3,941,069, INT. CL. 32.

JPI LIMITED, HUNGHOM, KOWLOON, HONG KONG:  
1,612,001, REN. 3-3-11. INT. CL. 14.

JR., YOUNGLOVE JOHN F., OXFORD, WI:  
2,368,374, CANC. INT. CL. 20.

JT INTERNATIONAL DISTRIBUTORS, INC., INDIANAPOLIS,  
IN:  
2,864,879, CANC. INT. CL. 18.

JTECH COMMUNICATIONS, INC., BOCA RATON, FL:  
2,367,540, CANC. INT. CL. 9.

JUICY COUTURE, INC., PACOIMA, CA:  
3,941,099, INT. CL. 24.

JUMINGY, INC., LOS ANGELES, CA:  
2,865,598, CANC. INT. CL. 3.

JUNGPFLANZEN GRÜNEWALD GMBH, FED REP GERMANY:  
3,123,869, COR. INT. CL. 31.

JUNGPFLANZEN GRÜNEWALD GMBH, 59379 SELM, FED  
REP GERMANY:  
3,127,092, COR. INT. CL. 31.

JUNGPFLANZEN GRÜNEWALD GMBH, FED REP GERMANY:  
3,133,242, COR. INT. CL. 31.  
3,142,413, COR. INT. CL. 31.  
3,194,719, COR. INT. CL. 31.  
3,194,720, COR. INT. CL. 31.  
3,204,226, COR. INT. CL. 31.  
3,211,682, COR. INT. CL. 31.  
3,211,690, COR. INT. CL. 31.  
3,218,331, COR. INT. CL. 31.  
3,247,809, COR. INT. CL. 31.

JUNIOR LEARNING INCORPORATED, HUNTINGTON  
BEACH, CA, DBA JUNIOR LEARNING INCORPORATED:  
3,942,093, INT. CL. 28.  
3,942,094, INT. CL. 28.  
3,942,095, INT. CL. 28.

JUNO LIGHTING, INC., DES PLAINES, IL:  
2,447,220, REN. 3-3-11. INT. CL. 11.

JUPITERMEDIA CORPORATION, DARIEN, CT:  
2,864,216, CANC. MULTIPLE CLASS, INT. CLS. 35 AND  
41.  
2,864,220, CANC. INT. CL. 41.  
2,864,235, CANC. INT. CL. 35.

JURISEARCH HOLDINGS LLC, LOS ANGELES, CA:  
2,368,564, CANC. INT. CL. 42.

JURLNNOV HOLDING LIMITED PARTNERSHIP, CLEVELAND,  
OH:  
3,941,263, MULTIPLE CLASS, INT. CLS. 41 AND 42.

JURY VERDICT REVIEW PUBLICATIONS, INC., SPRINGFIELD,  
NJ:  
1,641,229, REN. 3-3-11. INT. CL. 16.

JUST ONE BREAK, INC., NEW YORK, NY:  
2,423,485, REN. 2-28-11. MULTIPLE CLASS, INT. CLS. 16  
AND 35.

JUSTIN Z. TRUESDELL, HOUSTON, TX, DBA REBELS  
HONKY TONK:  
3,940,282, PUB. 1-18-2011. INT. CL. 41.

JYE'S INTERNATIONAL INC., SAN FRANCISCO, CA:  
2,318,938, CANC. INT. CL. 14.

K & B SEAFOOD, INC., EAST NORTHPORT, NY:  
2,715,665, CANC. INT. CL. 31.

K & G IMPORTS LLC, EL PRADO, NM:  
3,942,264, INT. CL. 33.

K-BOXING MEN'S WEAR CO., LTD., JINJIANG, FUJIAN  
PROVINCE, CHINA:  
2,431,836, REN. 3-1-11. INT. CL. 25.

K-LAK TECHNICAL ENTERPRISES, INC., WILMINGTON,  
DE:  
2,431,081, REN. 3-2-11. INT. CL. 35.

K-TEL INTERNATIONAL LTD., WINNIPEG, MANITOBA  
R3J 3W3, CANADA:  
3,939,349, PUB. 3-10-2009. MULTIPLE CLASS, INT. CLS.  
3, 9, 16, 28 AND 41.

K-9 ENTERPRISES, LLC, OTIS, CO:  
3,940,317, PUB. 1-18-2011. INT. CL. 21.

KAASI ASSOCIATE LLC, HOLBROOK, NY:  
3,941,891, INT. CL. 35.

KABUSHIKI KAISHA BANDAI, TOKYO, JAPAN:  
2,436,641, REN. 3-3-11. INT. CL. 9.

KABUSHIKI KAISHA BANDAI, TOKYO 111-8081, JAPAN,  
AKA BANDAI CO., LTD.:  
3,941,767, INT. CL. 28.  
3,941,856, INT. CL. 28.

KABUSHIKI KAISHA KENWOOD, TOKYO, JAPAN, TA  
KENWOOD CORPORATION:  
2,443,078, REN. 2-26-11. INT. CL. 9.

KABUSHIKI KAISHA KENWOOD, TOKYO, JAPAN:  
2,443,079, REN. 2-26-11. INT. CL. 9.

KABUSHIKI KAISHA NETWORK SUPPLY, NAGANO, JAPAN:  
2,865,232, CANC. INT. CL. 9.

KABUSHIKI KAISHA RALLIART, TOKYO, JAPAN:  
2,926,860, CANC. MULTIPLE CLASS, INT. CLS. 35, 37  
AND 41.

KABUSHIKI KAISHA RIKEN, CHIYODA-KU, TOKYO,  
JAPAN, RIKEN PISTON RING KOGYO KABUSHIKI  
KAISHA, CHIYODA-KU, TOKYO, JAPAN:  
1,159,059, REN. 2-26-11. INT. CL. 12.

KABUSHIKI KAISHA SONY COMPUTER ENTERTAINMENT,  
TOKYO, JAPAN, TA SONY COMPUTER ENTERTAINMENT  
INC.:  
2,863,923, CANC. INT. CL. 9.

KABUSHIKI KAISHA SQUARE ENIX, TOKYO, JAPAN, TA  
SQUARE ENIX CO. LTD.:  
3,939,405, PUB. 1-18-2011. MULTIPLE CLASS, INT. CLS.  
9, 16, 25 AND 28.

KABUSHIKI KAISHA SQUARE ENIX, TOKYO, JAPAN, TA  
SQUARE ENIX CO., LTD.:  
3,941,930, MULTIPLE CLASS, INT. CLS. 9 AND 41.

KABUSHIKI KAISHA TAITO, TOKYO 151-0053, JAPAN:  
3,942,091, INT. CL. 9.  
3,942,158, INT. CL. 9.

KADISON, DAVID, DOWNEY, CA:  
2,369,323, CANC. INT. CL. 25.

KAID INDUSTRIES INC./LES INDUSTRIES KAID INC.,  
MONTREAL, QUEBEC, CANADA:  
2,864,001, CANC. INT. CL. 25.  
2,864,129, CANC. INT. CL. 25.

KAIPARASOFT LIMITED, KUMEU, AUCKLAND, NEW  
ZEALAND:  
3,941,256, INT. CL. 9.

KALEIDA HEALTH, BUFFALO, NY:  
2,430,729, REN. 3-1-11. INT. CL. 42.

KALEXSYN, INC., KALAMAZOO, MI:  
2,865,265, CANC. INT. CL. 42.

KALLAMNI, MINA, NEW YORK, NY AND KALLAMNI,  
FOUAD, NEW YORK, NY:  
3,941,629, INT. CL. 30.

KAMPGROUNDS OF AMERICA, BILLINGS, MT:  
2,864,448, CANC. INT. CL. 38.

KANGOL LIMITED, SHIREBROOK NG 20 8RY, UNITED  
KINGDOM:  
2,864,909, CANC. INT. CL. 14.

- KANGRA GROUP (PROPRIETARY) LIMITED, JOHANNESBURG, SOUTH AFRICA:  
2,920,943, COR. INT. CL. 33.
- KAO KABUSHIKI KAISHA, TOKYO 103-8210, JAPAN, TA KAO CORPORATION:  
2,435,344, REN. 2-26-11. INT. CL. 3.
- KAP'S WHOLESALE FOOD SERVICES, INC., DETROIT, MI:  
3,941,804, INT. CL. 29.
- KAPAK COMPANY LLC, ST. LOUIS PARK, MN:  
2,368,965, CANC. INT. CL. 16.
- KAPLANIDIS, WILLIAM, BAYSIDE, NY AND SARMIENTO, REINE, BAYSIDE, NY:  
3,941,037, INT. CL. 16.
- KARAN R. MOSELEY, ARLINGTON, TX, DBA PREFERRED TEA:  
3,940,476, PUB. 1-18-2011. INT. CL. 30.
- KARCHER NORTH AMERICA, INC., ENGLEWOOD, CO:  
3,940,849, PUB. 1-18-2011. INT. CL. 3.
- KAREL, STEVEN, NEW YORK, NY:  
3,939,860, PUB. 10-5-2010. INT. CL. 41.
- KARL STORZ GMBH & CO. KG, TUTTLINGEN, FED REP GERMANY:  
3,939,440, PUB. 6-9-2009. MULTIPLE CLASS, INT. CLS. 10 AND 16.
- KARSTEN MANUFACTURING CORPORATION, PHOENIX, AZ:  
2,865,271, CANC. INT. CL. 28.
- KASHI COMPANY, LA JOLLA, CA:  
2,480,506, REN. 3-3-11. INT. CL. 30.
- KATE SOMERVILLE SKIN CARE LLC, LOS ANGELES, CA:  
3,941,184, INT. CL. 3.
- KATE SPADE, LLC, NEW YORK, NY:  
2,865,771, CANC. INT. CL. 25.
- KATRINA NICOLE GRIFFIS, CALLAWAY, MD, DBA PINK KOALA DESIGN:  
3,940,857, PUB. 1-18-2011. INT. CL. 18.
- KATUSHA MANAGEMENT SA, CH-1204 GENÈVE, SWITZERLAND:  
3,939,931, PUB. 1-18-2011. MULTIPLE CLASS, INT. CLS. 14, 18, 24, 25, 28, 35, 36, 39, 41 AND 45.
- KAVIARI SAS, FRANCE:  
3,939,966, PUB. 1-18-2011. INT. CL. 29.
- KAY CHEMICAL COMPANY, GREENSBORO, NC:  
2,368,184, CANC. MULTIPLE CLASS, INT. CLS. 3 AND 5.
- KAYTEE PRODUCTS INCORPORATED, CHILTON, WI:  
3,942,324, INT. CL. 31.
- KC PREFERRED, LLC, RAYMORE, MO:  
3,939,749, PUB. 1-18-2011. INT. CL. 35.
- KD DID, INC., CALABASAS, CA, DBA ENERGY ESSENTIALS:  
3,939,481, PUB. 1-18-2011. MULTIPLE CLASS, INT. CLS. 5, 16, 30, 41 AND 44.
- KEANE, INC., BOSTON, MA:  
3,941,594, INT. CL. 35.
- KEELING&ASSOCIATES, LLC, NEW YORK, NY:  
3,941,530, MULTIPLE CLASS, INT. CLS. 35 AND 41.
- KEGFLY LLC, UNIVERSITY HEIGHTS, OH:  
3,940,838, PUB. 1-18-2011. INT. CL. 35.  
3,940,916, PUB. 1-18-2011. INT. CL. 35.
- KELEMATA S.R.L., TORINO, ITALY:  
2,454,201, REN. 3-2-11. INT. CL. 3.
- KELLER, LINDA, COLORADO SPRINGS, CO:  
3,940,663, PUB. 1-18-2011. INT. CL. 35.
- KELLER, WILLIAM R., SR., EPHRATA, PA:  
3,941,509, INT. CL. 6.
- KELLNER, SAVILLE, ONTARIO, CA:  
3,940,534, PUB. 1-18-2011. INT. CL. 21.
- KELLOGG COMPANY, BATTLE CREEK, MI:  
921,229, REN. 3-3-11. U.S. CL. 46 (INT. CL. 30).
- KELLY-MOORE PAINT COMPANY, INC., SAN CARLOS, CA:  
3,939,855, PUB. 1-18-2011. INT. CL. 2.
- KEMCO SYSTEMS, INC., CLEARWATER, FL:  
3,940,991, INT. CL. 11.
- KEMIN INDUSTRIES, INC., DES MOINES, IA:  
2,864,383, CANC. MULTIPLE CLASS, INT. CLS. 30 AND 31.
- KEMIRA CHEMICALS, INC., KENNESAW, GA:  
3,939,678, PUB. 1-18-2011. INT. CL. 1.
- KENG, SHANE, ROSWELL, GA:  
3,941,853, INT. CL. 8.
- KENMORE CAMERA, INC., KENMORE, WA:  
2,471,299, CANC. INT. CL. 35.
- KENNEL-AIRE, LLC, NEENAH, WI:  
3,939,387, PUB. 1-18-2011. INT. CL. 20.
- KENNETH KHAI GAN CHUAH, AUSTIN, TX:  
2,865,659, CANC. INT. CL. 9.
- KENTINENTAL ENGINEERING LIMITED, SEVENOAKS, KENT, ENGLAND:  
1,639,009, REN. 3-3-11. INT. CL. 12.
- KEURIG, INCORPORATED, READING, MA:  
3,941,762, INT. CL. 11.  
3,941,763, INT. CL. 30.
- KEVIN BOULTON, DOUGLASVILLE, GA:  
3,941,314, MULTIPLE CLASS, INT. CLS. 4 AND 5.
- KEYSTONE RETAINING WALL SYSTEMS, INC., MINNEAPOLIS, MN:  
3,940,899, PUB. 1-18-2011. INT. CL. 19.
- KHADI NATURPRODUKTE GMBH, RINTELN, FED REP GERMANY:  
3,941,302, INT. CL. 3.
- KIA MOTORS CORPORATION, SEOUL, FED REP GERMANY:  
2,864,796, CANC. INT. CL. 12.
- KIAICO INC., MAHWAH, NJ:  
3,942,058, MULTIPLE CLASS, INT. CLS. 16, 21, 25 AND 28.
- KIAWAH RESORT ASSOCIATES LP, CHARLSTON, SC, KIAWAH ISLAND COMPANY LIMITED, CHARLESTON, SC:  
1,156,700, REN. 3-2-11. INT. CL. 41.
- KICKDISK, LLC, MERION STATION, PA:  
3,940,310, PUB. 1-18-2011. INT. CL. 15.
- KIDCO, INC., MUNDELEIN, IL:  
2,864,457, CANC. MULTIPLE CLASS, INT. CLS. 6 AND 19.
- KIDDIE CRUSOE, LLC, FOREST HILL, MD:  
3,941,676, INT. CL. 41.
- KIDS CARE, INC., VIENNA, VA:  
2,864,977, CANC. INT. CL. 3.
- KIKUCHI, INC., SEATTLE, WA:  
2,491,400, REN. 3-2-11. INT. CL. 42.
- KILBANE, MARGARET M., DETROIT LAKES, MN:  
3,941,890, INT. CL. 20.
- KILDA GROUP LLC, ANNAPOLIS, MD:  
3,940,764, PUB. 1-18-2011. INT. CL. 35.
- KIM SUN KYUNG, REPUBLIC OF KOREA:  
3,939,956, PUB. 10-12-2010. INT. CL. 25.
- KIM, IN JAE, SEOUL, REPUBLIC OF KOREA:  
2,864,753, CANC. INT. CL. 34.
- KIM, JAE, TOTOWA, NJ:  
3,941,886, INT. CL. 25.
- KIMBALL UNION ACADEMY, MERIDEN, NH:  
3,940,490, PUB. 1-18-2011. INT. CL. 41.
- KIMBALL, MEGHAN K., MT. CLEMENS, MI:  
3,940,864, PUB. 1-18-2011. INT. CL. 41.
- KIMBER IP, LLC, PHILADELPHIA, PA:  
2,865,478, CANC. INT. CL. 13.
- KIMPTON HOTEL & RESTAURANT GROUP, LLC, SAN FRANCISCO, CA:  
2,449,410, REN. 2-26-11. INT. CL. 42.
- KIN YAT INDUSTRIAL CO., LTD., KOWLOON, HONG KONG:  
2,369,123, CANC. INT. CL. 28.
- KING OF KNIVES PTY LIMITED, ROSEBERY NSW 2018, AUSTRALIA:  
3,939,905, PUB. 1-18-2011. MULTIPLE CLASS, INT. CLS. 8 AND 21.
- KINGSDOWN, INC., MEBANE, NC:  
3,942,427, INT. CL. 20.
- KINZINGER ENTERPRISES, INC., ST. LOUIS, MO:  
2,864,675, CANC. INT. CL. 35.  
2,864,676, CANC. INT. CL. 35.

KIRBY, WILLIAM B., SMYRNA, GA AND KIRBY, FRANKIE S., SMYRNA, GA:  
3,941,578, INT. CL. 25.

KIRKHOUSE PRODUCTIONS, LLC, AUSTIN, TX:  
3,941,250, INT. CL. 9.

KIRKWOOD MOUNTAIN RESORT, LLC, KIRKWOOD, CA:  
1,626,353, REN. 3-3-11. MULTIPLE CLASS, INT. CLS. 41 AND 42.

KISS NAIL PRODUCTS, INC., PORT WASHINGTON, NY:  
3,941,136, INT. CL. 3.  
3,941,137, INT. CL. 3.

KIT KAN PRODUCTIONS, INC., ROYAL PALM BEACH, FL:  
2,367,728, CANC. MULTIPLE CLASS, INT. CLS. 41 AND 42.

KITTRICH CORPORATION, LA MIRADA, CA:  
2,473,723, REN. 3-2-11. INT. CL. 20.

KIZAN INTERNATIONAL, INC., BRISBANE, CA:  
2,450,128, REN. 2-25-11. INT. CL. 25.

KLEENRITE, INC., ALBUQUERQUE, NM:  
2,865,219, CANC. INT. CL. 3.  
2,865,220, CANC. INT. CL. 3.

KLEIN FOODS, INC., HEALDSBURG, CA, DBA RODNEY STRONG VINEYARDS:  
3,942,171, INT. CL. 33.

KLEIN FOODS, INC. DBA RODNEY STRONG VINEYARDS, HEALDSBURG, CA:  
3,942,311, INT. CL. 33.

KLICKNATION CORPORATION, SACRAMENTO, CA:  
3,940,473, PUB. 1-18-2011. MULTIPLE CLASS, INT. CLS. 9 AND 41.

KLIMAIRE PRODUCTS INC., MIAMI, FL:  
3,940,226, PUB. 1-18-2011. INT. CL. 11.

KLINGHOFFER, STEVEN H., SPRINGFIELD, NJ:  
2,390,610, CANC. INT. CL. 16.  
2,390,649, CANC. INT. CL. 16.

KLIPPERT, JOEL, PUYALLUP, CA:  
3,941,843, INT. CL. 19.

KLOCKNER PENTAPLAST GMBH & CO. KG, HELIGENROTH, FED REP GERMANY:  
3,941,588, INT. CL. 17.

KLUTZ, PALO ALTO, CA:  
2,507,353, REN. 2-26-11. INT. CL. 28.  
2,507,353, COR. INT. CL. 28.

KMIEC LAW OFFICES, S.C., MILWAUKEE, WI:  
3,940,712, PUB. 1-18-2011. INT. CL. 45.

KMX, SOUTHSEA HANTS, UNITED KINGDOM:  
3,940,555, PUB. 1-18-2011. MULTIPLE CLASS, INT. CLS. 12 AND 28.

KNAPHEIDE MFG. CO., THE, QUINCY, IL:  
1,635,836, REN. 2-26-11. INT. CL. 42.

KNITTEL ENGRAVING CO. INC., MIAMITOWN, OH:  
2,864,610, CANC. INT. CL. 16.

KNOLWEDGE RETRIEVER, LLC, ERIE, CO:  
3,939,625, PUB. 1-18-2011. INT. CL. 16.

KNOT, INC., THE, NEW YORK, NY:  
2,494,405, REN. 3-2-11. INT. CL. 16.

KOA SPEER ELECTRONICS, INC., BRADFORD, PA:  
3,939,362, PUB. 1-18-2011. INT. CL. 9.

KOBI KATZ, INC., LOS ANGELES, CA, DBA BAGUETTE WORLD:  
2,494,979, REN. 2-26-11. INT. CL. 14.

KOBRAND CORPORATION, PURCHASE, NY:  
3,941,921, INT. CL. 33.

KOC, THOMAS, NORTH ARLINGTON, NJ:  
3,941,904, INT. CL. 6.

KOCH DEVELOPMENT CORPORATION, SANTA CLAUS, IN:  
3,939,875, PUB. 1-18-2011. INT. CL. 41.

KOFRICA ENTERTAINMENT INC., MALIBU, CA:  
2,418,221, CANC. INT. CL. 41.

KOKI ENTERPRISES, LLC, KIHEI, HI:  
3,941,726, INT. CL. 39.

KOLBE & KOLBE MILLWORK CO., INC., WAUSAU, WI:  
2,864,331, CANC. MULTIPLE CLASS, INT. CLS. 19, 35 AND 37.

KOMAR ALLIANCE, LLC, ELK GROVE VILLAGE, IL:  
3,940,532, PUB. 1-18-2011. INT. CL. 23.

KONA CLOUD COFFEE ESTATES INC, JONESBORO, AR:  
3,940,670, PUB. 1-18-2011. INT. CL. 30.

KONAMI CORPORATION, TOKYO, JAPAN:  
2,428,573, CANC. INT. CL. 16.

KONAMI DIGITAL ENTERTAINMENT CO., LTD., TOKYO, JAPAN:  
2,456,478, REN. 2-26-11. INT. CL. 28.

KONINKLIJKE AHREND N.V., 1101 EA AMSTERDAM, NETHERLANDS:  
3,939,661, PUB. 1-18-2011. MULTIPLE CLASS, INT. CLS. 20, 37 AND 42.

KONINKLIJKE PHILIPS ELECTRONICS N.V., EINDHOVEN, NETHERLANDS:  
2,865,181, CANC. INT. CL. 9.

KONVAX CORPORATION, CAMBRIDGE, MA:  
3,939,374, PUB. 1-18-2011. MULTIPLE CLASS, INT. CLS. 9 AND 42.

KOOKS CO., LTD., TOKYO, JAPAN:  
3,724,676, CANC. INT. CL. 25.

KORG INC., TOKYO, JAPAN:  
2,865,209, CANC. INT. CL. 15.

KORN SNACKS DEL PERU S.A.C., LIMA, PERU:  
3,942,153, INT. CL. 30.  
3,942,162, INT. CL. 30.

KOSCICA, STEPHEN, CHANDLER, AZ:  
2,865,243, CANC. INT. CL. 15.

KOSHER FOODS UNLIMITED, INC., LOS ANGELES, CA, DBA GOT KOSHER?:  
3,940,882, PUB. 1-18-2011. INT. CL. 30.

KOSSOR, STEVEN, COATESVILLE, PA:  
3,940,292, PUB. 1-18-2011. INT. CL. 44.

KOSTERS, EDWARD A., LOS ANGELES, CA, DBA ALEX KOSTERS:  
3,941,833, INT. CL. 25.

KOVACH, MATTHEW J, SYRACUSE, NY:  
3,941,219, INT. CL. 29.  
3,941,220, INT. CL. 29.

KRAFT FOODS GLOBAL BRANDS LLC, NORTHFIELD, IL:  
3,941,708, INT. CL. 32.  
3,941,755, INT. CL. 30.

KRAFT PIZZA COMPANY, NORTHFIELD, IL TO KRAFT PIZZA COMPANY, NORTHFIELD, IL:  
2,027,606, CANC. INT. CL. 30.

KRAVITZ, THOMAS J., LOS ANGELES, CA:  
2,368,053, CANC. INT. CL. 38.

KREMBS, INC., SIMI VALLEY, CA:  
2,864,702, CANC. INT. CL. 9.

KRIS LOGAN, CLEARWATER, FL:  
3,941,958, INT. CL. 18.

KROSLAK, JENNIFER, SCOTTSDALE, AZ:  
3,105,175, CANC. INT. CL. 25.

KRR INTERNATIONAL CORP., DOVER, DE:  
2,393,193, REN. 2-25-11. MULTIPLE CLASS, INT. CLS. 29 AND 42.

KUANG, GORDON, LITTLE NECK, NY:  
3,940,364, PUB. 1-18-2011. INT. CL. 44.

KUBOTA CORPORATION, OSAKA, JAPAN:  
2,461,035, REN. 2-26-11. MULTIPLE CLASS, INT. CLS. 7 AND 12.

KUHLSPORT LTD., CINCINNATI, OH:  
3,942,446, INT. CL. 41.

KUHN S.A., SAVERNE, FRANCE:  
2,927,773, CANC. MULTIPLE CLASS, INT. CLS. 8 AND 12.

KULI MELA ASSOCIATION, SHERMAN OAKS, CA:  
3,939,574, PUB. 1-18-2011. INT. CL. 35.

KURTZ, AIMEE, LA HASKA, PA:  
3,939,737, PUB. 1-18-2011. INT. CL. 41.

KW INTELLECTUAL PROPERTIES, INC., POLK CITY, FL:  
3,939,750, PUB. 1-18-2011. MULTIPLE CLASS, INT. CLS. 25 AND 41.

KWH MIRKA LTD., FINLAND:  
3,940,075, PUB. 1-18-2011. INT. CL. 3.

KWIATKOWSKI, JOSEPH M., JR., ALEXANDRIA, VA:  
2,474,853, REN. 2-26-11. INT. CL. 35.

KWIK TEK INC., GOLDEN, CO:  
2,663,358, CANC. INT. CL. 28.

- KWOK'S INTERNATIONAL HOLDINGS LIMITED, KOW-  
LOON, HONG KONG:  
2,865,091, CANC. INT. CL. 28.
- KYMA TECHNOLOGIES, INC., RALEIGH, NC:  
2,468,030, REN. 2-26-11, INT. CL. 9.
- K2 ADVISORS L.L.C., STAMFORD, CT:  
3,940,917, PUB. 1-18-2011, INT. CL. 36.
- L & J GENERAL INTERNATIONAL CORPORATION, INC.,  
MIAMI, FL:  
1,642,929, REN. 3-2-11, INT. CL. 29.
- L. BRENT AVERETT, CHANDLER, AZ, DBA MR. KNIFE-  
GUY, LLC:  
3,940,345, PUB. 1-18-2011, INT. CL. 35.
- L. PERRIGO COMPANY, ALLEGAN, MI:  
3,941,327, INT. CL. 5.
- L.A. ARENA COMPANY, LLC, LOS ANGELES, CA:  
2,468,374, REN. 2-25-11, INT. CL. 35.
- L.A. LOUVER GALLERY, INC., VENICE, CA:  
3,941,359, MULTIPLE CLASS, INT. CLS. 35 AND 41.  
3,941,360, MULTIPLE CLASS, INT. CLS. 35 AND 41.
- L.B. PLASTICS LIMITED, BELPER, DERBYSHIRE, ENG-  
LAND:  
2,864,014, CANC. MULTIPLE CLASS, INT. CLS. 17 AND  
19.
- L.C. LICENSING, INC., NEW YORK, NY:  
2,367,982, CANC. INT. CL. 18.
- L.D. BAILEY & ASSOCIATES LLC, WILSONVILLE, OR:  
2,865,212, CANC. INT. CL. 35.
- L&D DEVELOPMENT, INC., CORTEZ, CO:  
2,865,781, CANC. INT. CL. 43.
- L&G MORTGAGEBANC, SCOTTSDALE, AZ:  
2,864,380, CANC. MULTIPLE CLASS, INT. CLS. 36 AND  
41.
- L-1 IDENTITY SOLUTIONS, INC., STAMFORD, CT:  
2,864,965, CANC. INT. CL. 9.
- L'AIR LIQUIDE, SOCIETE ANONYME POUR L'ETUDE ET  
L'EXPLOITATION DES PROCEDES GEORGES CLAUDE,  
75321 PARIS CEDEX 07, FRANCE:  
2,431,952, REN. 3-3-11, INT. CL. 42.
- L'OREAL, 75008 PARIS, FRANCE:  
2,434,100, REN. 2-26-11, INT. CL. 3.
- L'OREAL, PARIS, FRANCE:  
2,864,384, CANC. INT. CL. 3.  
3,939,809, PUB. 1-18-2011, MULTIPLE CLASS, INT. CLS. 3  
AND 5.  
3,941,341, INT. CL. 3.
- L'OREAL USA CREATIVE, INC., NEW YORK, NY:  
2,865,323, CANC. INT. CL. 3.  
3,941,495, INT. CL. 3.  
3,941,519, INT. CL. 3.  
3,941,892, INT. CL. 3.
- L'ORMARINS (PTY) LIMITED, CAPE TOWN,, SOUTH  
AFRICA:  
3,939,398, PUB. 1-18-2011, INT. CL. 33.
- LA GUADALUPANA WHOLESALE CO., INC., CHICAGO,  
IL:  
2,863,900, CANC. INT. CL. 30.  
2,863,901, CANC. MULTIPLE CLASS, INT. CLS. 30 AND  
31.
- LA PETITE ACADEMY, INC., NOVI, MI:  
3,940,574, PUB. 1-18-2011, INT. CL. 41.
- LA TABACALERA, C. POR A., ENSANCHE LA PAZ,  
DOMINICAN REP:  
3,939,487, PUB. 1-18-2011, INT. CL. 34.
- LABORATOIRES DARPIN, PARIS, FRANCE:  
3,939,962, PUB. 1-18-2011, INT. CL. 3.
- LABORATOIRES FORTE PHARMA S.A.M, MONACO,  
MONACO:  
3,941,595, INT. CL. 5.
- LABRADA BODYBUILDING NUTRITION, INC., HOUS-  
TON, TX:  
2,864,118, CANC. INT. CL. 41.
- LACOFF, BRANDON, GREENWICH, CT:  
3,939,837, PUB. 1-18-2011, INT. CL. 45.
- LADIES WHO BRAND, INC., PHOENIX, AZ:  
3,940,544, PUB. 1-18-2011, INT. CL. 35.
- LAKE AREA CHAMBER OF COMMERCE, INC., LAKE  
OZARK, MO:  
3,940,400, PUB. 1-18-2011, INT. CL. 35.
- LAKE CAROLINA DEVELOPMENT, INC., COLUMBIA, SC:  
2,495,905, REN. 3-2-11, MULTIPLE CLASS, INT. CLS. 36  
AND 37.
- LAKE RIDGE VINEYARDS, LLC, SAINT HELENA, CA:  
3,941,829, INT. CL. 33.
- LAKELAND VETERINARY SERVICES, INC., KNOXVILLE,  
TN, DBA MY PET'S ANIMAL HOSPITAL:  
2,865,113, CANC. INT. CL. 44.
- LAMBDA THETA NU SORORITY, INC., SAN DIEGO, CA:  
3,940,195, PUB. 1-18-2011, MULTIPLE CLASS, INT. CLS.  
16, 18 AND 25.
- LAMOTTE CHEMICAL PRODUCTS COMPANY, CHESTER-  
TOWN, MD:  
3,939,805, PUB. 1-18-2011, INT. CL. 9.
- LANCE ARMSTRONG FOUNDATION, AUSTIN, TX:  
3,939,727, PUB. 1-18-2011, INT. CL. 16.
- LAND AND SKY, INC., LINCOLN, NE:  
2,865,240, CANC. INT. CL. 20.
- LAND O'LAKES PURINA FEED LLC, SHOREVEIW, MN:  
3,941,770, INT. CL. 31.
- LAND O'LAKES PURINA FEED LLC., SHOREVIEW, MN:  
1,154,125, REN. 3-3-11, INT. CL. 31.
- LAND TEJAS COMPANIES, L.L.C., HOUSTON, TX:  
2,864,233, CANC. INT. CL. 37.
- LANDAU UNIFORMS, INCORPORATED, OLIVE BRANCH,  
MS:  
3,940,160, PUB. 10-12-2010, INT. CL. 25.
- LANDS' END DIRECT MERCHANTS, INC., RICHFIELD,  
MN:  
2,865,195, CANC. INT. CL. 25.
- LAND4LESS.US, LLC, QUEEN CREEK, AZ:  
3,942,439, INT. CL. 36.
- LANGER BIOMECHANICS, INC., DEER PARK, NY:  
3,941,182, MULTIPLE CLASS, INT. CLS. 10 AND 44.
- LANGER RESEARCH ASSOCIATES LLC, NEW YORK, NY:  
3,940,428, PUB. 1-18-2011, INT. CL. 35.
- LANGNESE HONIG GMBH & CO. KG, 22941 BARGTE-  
HEIDE, FED REP GERMANY, V. E. H. LANGNESE,  
BARGTEHEIDE, FED REP GERMANY:  
1,183,143, REN. 2-25-11, INT. CL. 30.
- LANGSFELD & ASSOCIATES, LTD., INCLINE VILLAGE,  
NV:  
3,941,409, INT. CL. 35.  
3,941,410, INT. CL. 35.  
3,941,411, INT. CL. 36.
- LANKOVA, KATERINA, NEW YORK, NY:  
3,941,920, INT. CL. 25.
- LAPPERT'S, INC., HANAPEPE, HI:  
3,939,410, PUB. 6-2-2009, INT. CL. 30.
- LAS VEGAS PAIUTE TRIBE, LAS VEGAS, NV:  
2,456,178, REN. 3-3-11, INT. CL. 28.  
2,456,179, REN. 3-3-11, INT. CL. 25.  
2,462,550, REN. 3-3-11, INT. CL. 16.
- LATIN INTELLECTUAL PROPERTIES, INC., LOS AN-  
GELES, CA:  
3,941,149, INT. CL. 43.
- LATINOISE.COM, CHULA VISTA, CA:  
2,629,372, CANC. MULTIPLE CLASS, INT. CLS. 35 AND  
41.
- LAUDA DR. R. WOBSEY GMBH & CO. KG, 97922 LAUDA-  
KÖNIGSHOFEN, FED REP GERMANY:  
3,669,459, COR. INT. CL. 9.
- LAURA GELLER MAKE-UP STUDIOS, LTD, NEW YORK,  
NY:  
3,942,225, INT. CL. 3.
- LAURA HAGAN, FLORAL PARK, NY, DBA MY BOBOLI-  
NO:  
3,941,446, INT. CL. 24.
- LAUREATE EDUCATION, INC., BALTIMORE, MD:  
3,941,173, INT. CL. 42.
- LAUREL SPRINGS SCHOOL, OJAI, CA:  
3,649,780, CANC. INT. CL. 41.
- LAVA MARKETING INC., TUSTIN, CA, DBA THE MOD-  
CHIK:  
3,940,452, PUB. 1-18-2011, INT. CL. 41.



LAWLER, THOMAS J, STONE MOUNTAIN, GA:  
2,440,815, CANC. INT. CL. 5.

LAWN DOCTOR, INC., HOLMDEL, NJ:  
3,941,720, INT. CL. 44.

LAWSON, ERIC J., PLAINWELL, MI:  
2,565,339, CANC. INT. CL. 16.

LAW29 A PROFESSIONAL CORPORATION, NORTH HOLLYWOOD, CA:  
3,939,356, PUB. 1-18-2011. INT. CL. 45.

LBB ENTERPRISES, LLC, HENDERSON, NV, DBA IDIGYA:  
3,942,193, INT. CL. 45.

LCFE, LLC, MARIETTA, GA:  
2,865,496, CANC. INT. CL. 41.  
2,865,497, CANC. INT. CL. 41.

LE GROUPE FRUITS & PASSION INC./THE FRUITS & PASSION GROUP INC., CANDIAC QUEBEC, CANADA:  
2,944,455, CANC. INT. CL. 5.

LE SAINT COMPANIES, APPLE VALLEY, MN, DBA ACTIVE-DUTY:  
3,939,864, PUB. 1-18-2011. INT. CL. 42.

LEANLOGISTICS.COM, HOLLAND, MI:  
2,466,627, REN. 2-25-11. INT. CL. 39.

LEAPFROG ENTERPRISES, INC., EMERYVILLE, CA:  
3,941,694, INT. CL. 28.

LEARNING DIVIDENDS INC., CALGARY, ALBERTA, CANADA:  
2,863,955, CANC. MULTIPLE CLASS, INT. CLS. 9, 16 AND 41.

LEARNING SPRINGS, INC., OJAI, CA:  
3,751,124, CANC. INT. CL. 41.

LEASEHOLD CONSULTANTS, LLC, SCOTTSDALE, AZ:  
2,864,458, CANC. INT. CL. 36.

LEATHEN S. STEARN, FT. LAUDERDALE, FL:  
3,941,875, INT. CL. 18.

LEAVE ME B, CARLSBAD, CA:  
3,941,538, INT. CL. 25.

LEAVITT MEDICAL ASSOCIATES OF FLORIDA, INC., MAITLAND, FL:  
2,354,705, CANC. MULTIPLE CLASS, INT. CLS. 9 AND 42.

LEBANON SEABOARD CORPORATION, LEBANON, PA, SOILIZER CORPORATION, NEW HAVEN, CT:  
1,636,589, REN. 3-2-11. INT. CL. 1.

LEBELLOT, LEONARDO S., NORTH MIAMI BEACH, FL:  
2,864,251, CANC. INT. CL. 41.

LEE, DAVID G, DECATUR, GA:  
3,940,380, PUB. 1-18-2011. INT. CL. 39.

LEGACY COMPANIES, LLC, THE, HINGHAM, MA:  
2,369,608, CANC. INT. CL. 41.

LEGAL SA, 76620 LE HAVRE, FRANCE:  
2,863,979, CANC. INT. CL. 30.

LEGRAND FRANCE, LIMOGES, FRANCE:  
1,149,302, REN. 2-26-11. INT. CL. 9.

LEIGH, JENNIFER, BASALT, CO, DBA FILM WORKS COACHING:  
2,864,124, CANC. INT. CL. 41.

LENCO MARINE, INC., STUART, FL:  
3,941,449, INT. CL. 9.

LENNOX INDUSTRIES INC., RICHARDSON, TX:  
2,430,398, REN. 2-26-11. INT. CL. 9.

LENOX CORPORATION, BRISTOL, PA:  
3,940,128, PUB. 1-18-2011. INT. CL. 14.

LEO WILSON, RED LODGE, MT:  
3,939,634, PUB. 1-18-2011. INT. CL. 41.

LEO-ANDRIEU, GRACE, 75008 PARIS, FRANCE:  
2,575,681, CANC. INT. CL. 3.

LEONARD, CHARLOTTE, STARKVILLE, MS:  
3,942,087, INT. CL. 24.

LEONARD, JONATHAN A., SANDWICH, MA:  
2,864,792, CANC. INT. CL. 9.

LEONORE DOSKOW, INC., MONTROSE, NY:  
1,668,253, REN. 3-3-11. INT. CL. 14.  
1,668,253, CANC. INT. CL. 8.

LEROY HILL COFFEE COMPANY, INC., MOBILE, AL, LEROY HILL COFFEE COMPANY, INC., MOBILE, AL:  
2,530,124, REN. 2-26-11. INT. CL. 30.

LES AGENCES CAOPLAST, INC., GRANBY, CANADA:  
3,941,095, INT. CL. 11.

LESAFFRE ET COMPAGNIE, 75001 PARIS, FRANCE:  
2,460,913, REN. 3-2-11. INT. CL. 30.

LESLI S. OTT, NEW HAVEN, CT:  
3,941,187, INT. CL. 21.

LESSONPOP, INC, DELRAY BEACH, FL, AKA LESSON-POP.COM:  
3,940,123, PUB. 1-18-2011. INT. CL. 9.

LESTER LAMPERT, INC., CHICAGO, IL:  
2,438,234, REN. 2-26-11. MULTIPLE CLASS, INT. CLS. 14, 35 AND 37.

LEVENGER COMPANY, DELRAY BEACH, FL:  
2,471,685, REN. 2-25-11. INT. CL. 16.

LEVI, GENO R., BETHEL PARK, PA AND LEVI, CYNTHIA N., BETHEL PARK, PA:  
3,941,905, INT. CL. 3.

LEVITON MANUFACTURING CO., INC., MELVILLE, NY:  
2,482,917, REN. 2-26-11. INT. CL. 9.

LEVITT AND SONS, LLC, BOCA RATON, FL:  
2,865,818, CANC. INT. CL. 37.

LEWIS SEED CO., SHEDD, OR:  
2,503,073, REN. 3-1-11. INT. CL. 31.

LEWIS, MICHAEL A., LA PLATA, MD:  
3,940,289, PUB. 1-18-2011. INT. CL. 37.

LEXINGTON HOME BRANDS, LEXINGTON, NC:  
2,865,724, CANC. INT. CL. 20.

LEYLEGAL, LLC, CHAGRIN FALLS, OH:  
3,940,253, PUB. 1-18-2011. INT. CL. 45.

LF, LLC, MOUNT MOURNE, NC:  
2,433,137, REN. 2-25-11. MULTIPLE CLASS, INT. CLS. 35 AND 42.  
2,919,499, CANC. MULTIPLE CLASS, INT. CLS. 8 AND 25.  
3,939,555, PUB. 1-18-2011. INT. CL. 35.  
3,939,556, PUB. 1-18-2011. INT. CL. 35.  
3,941,343, INT. CL. 35.

LG ELECTRONICS INC., SEOUL, REPUBLIC OF KOREA:  
2,864,215, CANC. MULTIPLE CLASS, INT. CLS. 7, 9, 11 AND 38.

LG LICENSING, LLC, MIAMI, FL:  
3,942,026, MULTIPLE CLASS, INT. CLS. 8, 20, 21, 24 AND 27.

LG VERWALTUNGS, GMBH, DORTMUND, FED REP GERMANY:  
3,390,654, COR. INT. CL. 35.  
3,411,318, COR. INT. CL. 17.  
3,411,321, COR. INT. CL. 39.  
3,433,828, COR. INT. CL. 11.  
3,433,829, COR. INT. CL. 16.

LIBERTA FAMILY OFFICES SERVICES COMPANY, CHICAGO, IL:  
3,941,277, INT. CL. 36.  
3,941,279, INT. CL. 36.

LIBERTY MUTUAL INSURANCE COMPANY, BOSTON, MA:  
2,864,878, CANC. INT. CL. 36.

LIBERTY PUBLISHING, INC., BEVERLY, MA:  
2,435,884, REN. 2-25-11. INT. CL. 16.

LIBERTY UNIVERSITY, INC., LYNCHBURG, VA:  
3,939,451, PUB. 1-18-2011. INT. CL. 41.

LIDIAS KITCHEN LLC, NEW YORK, NY:  
2,864,481, CANC. INT. CL. 21.

LIDL STIFTUNG & CO. KG, D-74167 NECKARSULM, FED REP GERMANY:  
2,863,961, CANC. INT. CL. 33.

LIESKOVAN, EDWARD M., ANAHEIM, CA:  
2,427,338, REN. 2-26-11. INT. CL. 5.

LIEVANO, CORTES RONNEY, PEMBROKE PINES, FL:  
2,369,264, CANC. INT. CL. 3.

LIFE STUDIO INC., LARCHMONT, NY:  
3,940,769, PUB. 1-18-2011. INT. CL. 30.

LIFELINK CORPORATION, BENSONVILLE, IL:  
3,940,648, PUB. 1-18-2011. INT. CL. 45.

LIFESOUTH COMMUNITY BLOOD CENTERS, GAINESVILLE, FL:  
3,940,642, PUB. 1-18-2011. INT. CL. 44.

LIFESTYLE FITNESS, INC., MOORHEAD, MN:  
3,940,645, PUB. 1-18-2011. INT. CL. 28.

- LIFESYNC MEDIA GROUP INC., FAIRFAX, VA:  
3,939,713, PUB. 1-18-2011. INT. CL. 9.
- LIFTED RESEARCH GROUP INC., IRVINE, CA:  
3,942,057, MULTIPLE CLASS, INT. CLS. 16 AND 28.
- LIGAMED MEDICAL PRODUKTE GMBH, 90556 CADOLZBURG, FED REP GERMANY:  
3,940,053, PUB. 1-18-2011. INT. CL. 5.
- LIGHTSTAT, INC., BARKHAMSTED, CT:  
1,651,397, REN. 2-25-11. INT. CL. 9.
- LILE, THOMAS A., HOUSTON, TX:  
2,864,112, CANC. INT. CL. 3.
- LILLY'S CLEANING SERVICE, INC, GAITHERSBURG, MD, DBA LCS COMMERCIAL:  
3,939,788, PUB. 1-18-2011. INT. CL. 37.
- LILYBETH GOLF LLC, LAKE BLUFF, IL:  
3,940,445, PUB. 1-18-2011. INT. CL. 28.
- LIN, JIMMY, BUENA PARK, CA:  
3,941,810, INT. CL. 25.
- LINCO INC., SANTA FE SPRINGS, CA:  
3,941,549, MULTIPLE CLASS, INT. CLS. 9 AND 11.
- LINCOLN GLOBAL, INC., CLEVELAND, OH, LINCOLN GLOBAL, INC., CLEVELAND, OH:  
2,394,140, REN. 2-25-11. INT. CL. 9.
- LION BIOSCIENCE LTD., CAMBRIDGE, CB4 1 DL, UNITED KINGDOM:  
2,864,274, CANC. MULTIPLE CLASS, INT. CLS. 9 AND 42.
- LIS, PAUL, FARMINGTON, CT:  
3,941,082, INT. CL. 41.
- LISA FRANK, INC., TUCSON, AZ:  
2,865,614, CANC. INT. CL. 16.
- LISK, STANTON E., III, GLENFIELD, NY:  
2,865,828, CANC. INT. CL. 12.
- LITIGATION GRAPHIC TECHNOLOGY, LOS ANGELES, CA:  
3,939,360, PUB. 1-18-2011. INT. CL. 42.
- LITT/COLE CORP., NEW YORK, NY, DBA 100% GUM-DROP:  
3,940,349, PUB. 1-18-2011. INT. CL. 14.
- LITTLE NY ENTERPRISES, INC., ALBANY, NY, DBA CAPITAL KIDZWEAR:  
3,941,486, INT. CL. 25.
- LIVE IT EVERYDAY, LLC, LEXINGTON, KY:  
3,941,300, MULTIPLE CLASS, INT. CLS. 25 AND 35.
- LIVEDEVICES LIMITED, YORK, YO10 5DG, UNITED KINGDOM:  
2,864,064, CANC. MULTIPLE CLASS, INT. CLS. 9, 16, 38 AND 42.
- LIVING HISTORY FARMS FOUNDATION, INC., URBAN-DALE, IA:  
2,621,093, CANC. INT. CL. 41.
- LIZ CLAIBORNE, INC., NEW YORK, NY:  
2,865,211, CANC. INT. CL. 25.
- LLJ USA, LLC, DORR, MI, DBA WWW.LLJUSA.COM:  
3,941,797, INT. CL. 35.
- LM GLASFIBER A/S, DENMARK:  
3,940,005, PUB. 1-18-2011. MULTIPLE CLASS, INT. CLS. 7 AND 17.
- LMGH, LLC, TAMPA, FL:  
3,941,597, INT. CL. 36.
- LOBATO, LOLA, SUNNY ISLES, FL:  
3,940,854, PUB. 1-18-2011. INT. CL. 41.
- LOBAUGH, BRANDON, FAYETTEVILLE, AR:  
3,939,680, PUB. 1-18-2011. INT. CL. 29.
- LOBDELL, VINCENT G., PULASKI, NY:  
2,865,557, CANC. INT. CL. 11.
- LOCAL MUZ, LLC, SOUTH LYME, CT:  
3,942,169, INT. CL. 36.  
3,942,170, INT. CL. 41.
- LOCAL PRIDE LLC, WEST ORANGE, NJ:  
3,941,934, INT. CL. 29.
- LOCH LLOYD TRAVEL CONSULTANTS, BELTON, MO:  
2,865,819, CANC. INT. CL. 35.
- LOERZEL, CHRISTOPHER, BROOKLYN, NY:  
3,942,201, INT. CL. 29.
- LOGAN, G. MICHAEL, KINGSPORT, TN:  
2,368,345, CANC. INT. CL. 35.
- LOGICBAY CORPORATION, PROVIDENCE, RI:  
2,435,251, REN. 2-28-11. INT. CL. 42.
- LOGON DATA CORPORATION, ORANGE, CA:  
2,453,168, CANC. INT. CL. 42.
- LOGOS COMMUNICATIONS INCORPORATED, BROOKLYN, NY:  
2,490,134, CANC. INT. CL. 35.
- LOLLIPOP ROCK, LLC, ATLANTA, GA:  
2,864,190, CANC. INT. CL. 9.
- LOMINGER LIMITED, INC., MINNEAPOLIS, MN, DBA LOMINGER INTERNATIONAL, A KORN/FERRY COMPANY:  
3,941,126, MULTIPLE CLASS, INT. CLS. 16 AND 42.
- LONG ISLAND DUCKS PROFESSIONAL BASEBALL CLUB, LLC, CENTRAL ISLIP, PA:  
2,466,655, REN. 2-26-11. INT. CL. 41.
- LONG ISLAND NETWORKING ELITE, GARDEN CITY, NY:  
3,939,633, PUB. 1-18-2011. INT. CL. 35.
- LONG, DEREK, SAN MARCOS, CA:  
3,940,466, PUB. 1-18-2011. INT. CL. 44.
- LONG, ROBERT EMERSON, NEWAYGO, MI:  
3,940,987, INT. CL. 25.
- LONGHORN DENTAL ASSOCIATES, P.C., AUSTIN, TX:  
2,864,442, CANC. INT. CL. 44.  
2,864,468, CANC. INT. CL. 44.
- LONGHORN VACCINES AND DIAGNOSTICS, LLC, SAN ANTONIO, TX:  
3,939,755, PUB. 1-18-2011. MULTIPLE CLASS, INT. CLS. 1 AND 5.
- LONGWAVE, LOS ANGELES, CA:  
2,864,198, CANC. INT. CL. 9.
- LONIGRO, CRAIG SCOTT, BLUE POINT, NY:  
3,940,904, PUB. 1-18-2011. INT. CL. 10.
- LONZA SALES AG, BASEL, SWITZERLAND:  
2,524,653, REN. 2-26-11. INT. CL. 1.  
2,524,654, REN. 2-26-11. INT. CL. 1.
- LOOPROPE, LLC, MEDFORD, OR:  
3,942,441, INT. CL. 22.
- LORD & BERRY INTERNATIONAL S.A., LUXEMBOURG, LUXEMBOURG:  
2,865,059, CANC. INT. CL. 3.
- LORENTZ SOLUTION, INC., FREMONT, CA:  
2,865,203, CANC. INT. CL. 9.
- LORI ALSENIH, ALLEN, TX, DBA EVER GIVING BOX:  
3,940,496, PUB. 1-18-2011. INT. CL. 16.
- LORI GOLDSTEIN, NEW YORK, NY:  
3,941,883, INT. CL. 25.
- LORI L. SILVERMAN, MESA, AZ AND KAREN DIETZ, SAN DIEGO, AZ:  
3,941,244, INT. CL. 35.
- LOS ANGELES DODGERS LLC, LOS ANGELES, CA:  
1,635,618, REN. 3-3-11. INT. CL. 30.
- LOTTA LUV, LLC, NEW YORK, NY:  
3,940,554, PUB. 1-18-2011. INT. CL. 35.
- LOUIS FONG, SAN JOSE, CA, DBA JCLU FOREVER AND KIMBERLY FONG, SAN JOSE, CA, DBA JCLU FOREVER:  
3,940,090, PUB. 1-18-2011. INT. CL. 25.  
3,940,098, PUB. 1-18-2011. INT. CL. 25.
- LOUIS M. KFOURY FUNERAL SERVICE, WEST ROXBURY, MA:  
2,864,870, CANC. INT. CL. 45.
- LOUISIANA AMMUNITION COMPANY, L.L.C., LAFAYETTE, LA:  
3,941,308, INT. CL. 13.  
3,941,311, INT. CL. 13.  
3,941,312, INT. CL. 13.
- LOUISIANA DIABETES FOUNDATION, INC., BATON ROUGE, LA:  
2,369,589, CANC. INT. CL. 42.
- LOUISVILLE LADDER INC., LOUISVILLE, KY:  
3,941,113, INT. CL. 20.
- LOVE A CHILD, INC., NAPLES, FL:  
2,368,860, CANC. INT. CL. 42.
- LOVE IT LLC, EAST AMHERST, NY:  
3,940,978, INT. CL. 35.
- LOXOGON, INC., OAKBROOK TERRACE, IL:  
3,939,710, PUB. 1-18-2011. INT. CL. 9.

LOZANO, CARLOS, HIALEAH GARDENS, FL:  
 3,940,750, PUB. 1-18-2011. INT. CL. 30.  
 3,940,751, PUB. 1-18-2011. INT. CL. 30.  
 3,940,752, PUB. 1-18-2011. INT. CL. 30.  
 LP CAPITAL ADVISORS, LLC, SACRAMENTO, CA:  
 3,940,233, PUB. 1-18-2011. MULTIPLE CLASS, INT. CLS. 9  
 AND 36.  
 LP CREATIVE, TWINSBURG, OH:  
 3,941,445, INT. CL. 16.  
 LP WATCH GROUP, INC., HOLLYWOOD, FL:  
 2,510,300, CANC. INT. CL. 14.  
 LRC PRODUCTS LIMITED, LONDON EC4V 6BW, GREAT  
 BRITAIN:  
 2,414,309. REN. 2-28-11. MULTIPLE CLASS, INT. CLS. 5  
 AND 10.  
 LSI INDUSTRIES INC., CINCINNATI, OH:  
 1,663,162. REN. 3-3-11. INT. CL. 6.  
 LUBRICATION SPECIALTIES, MOUNT GILEAD, OH:  
 3,942,443, MULTIPLE CLASS, INT. CLS. 4 AND 35.  
 LUBRIZOL ADVANCED MATERIALS, INC., CLEVELAND,  
 OH:  
 2,463,082. REN. 2-28-11. INT. CL. 1.  
 LUBRIZOL CORPORATION, THE, WICKLIFFE, OH:  
 2,455,946. REN. 2-25-11. INT. CL. 1.  
 LUCASFILM ENTERTAINMENT COMPANY LTD., SAN  
 FRANCISCO, CA:  
 2,428,899. REN. 2-26-11. INT. CL. 9.  
 3,939,491, PUB. 1-18-2011. MULTIPLE CLASS, INT. CLS.  
 25 AND 28.  
 LUCIC ENTERPRISES, INC., MENTOR, OH:  
 3,532,880, CANC. INT. CL. 43.  
 LUFKIN INDUSTRIES, INC., LUFKIN, TX:  
 2,904,564, CANC. INT. CL. 9.  
 LUIS CARLOS MORO GONZALEZ, E-28035 MADRID,  
 SPAIN:  
 3,940,045, PUB. 1-18-2011. INT. CL. 33.  
 LUMAT INC., SAN FRANCISCO, CA:  
 3,939,703, PUB. 1-18-2011. INT. CL. 32.  
 LUMETA, INC., IRVINE, CA:  
 3,861,250, CANC. INT. CL. 19.  
 LUMETIQUE, INC., LOS ANGELES, CA:  
 2,865,443, CANC. INT. CL. 4.  
 LUMINIAH DESIGNS CORPORATION, CANYON COUN-  
 TRY, CA:  
 3,941,368, INT. CL. 14.  
 LUSSIER, DENIS, VERNON, NJ:  
 3,940,422, PUB. 1-18-2011. INT. CL. 42.  
 LUTHER EDWIN MILLER, WATERLOO, CANADA:  
 3,941,461, INT. CL. 28.  
 LUTRON ELECTRONICS CO., INC., COOPERSBURG, PA:  
 1,638,913. REN. 2-26-11. INT. CL. 9.  
 LUTZ ENTERPRISES, INC., PLEASANT HILL, CA, DBA  
 NOVA CHROME:  
 2,368,410, CANC. INT. CL. 9.  
 LUX DE VILLE INC, SIGNAL HILL, CA:  
 3,939,612, PUB. 1-18-2011. INT. CL. 18.  
 LV3, LLC, BELLEFONTAINE, OH:  
 3,941,709, MULTIPLE CLASS, INT. CLS. 9, 25 AND 41.  
 LYCONIC, LLC, OMAHA, NE:  
 3,942,347, INT. CL. 42.  
 LYCOS, INC., WALTHAM, MA:  
 2,430,171. REN. 2-26-11. INT. CL. 38.  
 LYNN ROBERTS INTERNATIONAL, INC., OMAHA, NE:  
 2,863,967, CANC. INT. CL. 9.  
 LYONS, LEON, SCOTTSDALE, AZ:  
 3,941,179, INT. CL. 7.  
 LYRASIS, ATLANTA, GA:  
 3,941,349, MULTIPLE CLASS, INT. CLS. 35, 39, 40, 41  
 AND 42.  
 M & E MANUFACTURING CO., INC., KINGSTON, NY:  
 2,429,806. REN. 3-2-11. INT. CL. 6.  
 M & M ELECTRIC SERVICE, INC., GASTONIA, NC:  
 2,368,916, CANC. INT. CL. 9.  
 M S PARR ENTERPRISES INC., CHICAGO, IL:  
 3,941,605, INT. CL. 3.  
 M. CHAPOUTIER, FRANCE:  
 3,939,965, PUB. 1-18-2011. INT. CL. 33.  
 M. KELLIE GUTHRIE, OPELIKA, AL:  
 3,940,471, PUB. 1-18-2011. INT. CL. 20.  
 M. SCHAEERER AG, MOOSSEEDORF, SWITZERLAND:  
 2,864,812, CANC. INT. CL. 11.  
 M.E. FIELDS, INC., GLENCOE, IL:  
 2,299,845, CANC. INT. CL. 16.  
 M.G. STONE TRADE, INC., MIAMI BEACH, FL:  
 3,941,331, INT. CL. 19.  
 M.Z.BERGER & CO., INC., LONG ISLAND CITY, NY:  
 3,942,099, INT. CL. 14.  
 M&C LIGHTING CO., LTD., DONGGUAN, GUANGDONG,  
 CHINA:  
 3,940,176, PUB. 1-18-2011. INT. CL. 11.  
 M&G DURAVENT, INC., VACAVILLE, CA:  
 2,381,546. REN. 3-2-11. INT. CL. 6.  
 MABE, LLC, CINCINNATI, OH:  
 3,941,972, INT. CL. 36.  
 MACDERMID ACUMEN, INC., MIDDLETOWN, DE:  
 512,523, CANC. U.S. CL. 4.  
 MACDERMID INCORPORATED, WATERBURY, CT TO  
 MACDERMID ACUMEN, INC., MIDDLETOWN, DE:  
 678,718, CANC. U.S. CL. 6.  
 MACK GRETCHEN, DUBOIS, WY:  
 3,939,552, PUB. 1-18-2011. INT. CL. 35.  
 MACMILLAN USA, INC., INDIANAPOLIS, IN:  
 2,379,503. REN. 2-26-11. INT. CL. 16.  
 MACNEIL IP LLC, BOLINGBROOK, IL:  
 3,940,301, PUB. 1-18-2011. MULTIPLE CLASS, INT. CLS.  
 12, 22 AND 27.  
 MACROSYSTEM US INC., BOULDER, CO:  
 2,865,054, CANC. INT. CL. 9.  
 MACY'S MERCHANDISING GROUP, INC., NEW YORK,  
 NY:  
 2,379,773. REN. 2-28-11. INT. CL. 25.  
 MACY'S, INC., CINCINNATI, OH:  
 2,865,710, CANC. MULTIPLE CLASS, INT. CLS. 8 AND  
 21.  
 2,865,711, CANC. INT. CL. 21.  
 MADE IN VENETO LLC, DALLAS, TX:  
 2,865,792, CANC. INT. CL. 9.  
 MADELAINE CHOCOLATE NOVELTIES, INC., ROCK-  
 AWAY BEACH, NY, DBA THE MADELAINE CHOCO-  
 LATE COMPANY:  
 3,941,803, INT. CL. 30.  
 MADICO, INC., WOBURN, MA:  
 3,942,161, INT. CL. 17.  
 MADISON SQUARE GARDEN, L.P., NEW YORK, NY:  
 2,865,596, CANC. INT. CL. 41.  
 MADIZAC ENTERPRISE COMPANY LIMITED, KOW-  
 LOON, HONG KONG:  
 3,941,703, INT. CL. 25.  
 MAES JONKER, NAAMLOZE VENNOOTSCHAP, BEL-  
 GIUM:  
 3,939,896, PUB. 1-18-2011. MULTIPLE CLASS, INT. CLS.  
 6, 7 AND 8.  
 MAGIC HAT IP, LLC, BURLINGTON, VT:  
 3,942,133, INT. CL. 32.  
 MAGICJACK LP, WEST PALM BEACH, FL:  
 3,618,511, COR. MULTIPLE CLASS, INT. CLS. 9 AND 38.  
 MAGMA PRODUCTS, INC., LAKEWOOD, CA:  
 2,381,053. REN. 3-2-11. INT. CL. 11.  
 MAGNETI MARELLI S.P.A., ITALY:  
 3,939,906, PUB. 1-18-2011. MULTIPLE CLASS, INT. CLS.  
 7, 9 AND 12.  
 MAHLE ENGINE COMPONENTS USA, MUSKEGON, MI:  
 2,864,151, CANC. INT. CL. 7.  
 MAHOU, S.A., SPAIN:  
 3,940,049, PUB. 1-18-2011. MULTIPLE CLASS, INT. CLS.  
 32 AND 39.  
 MAIN STREET ACQUISITION CORP., LAS VEGAS, NV:  
 3,941,118, INT. CL. 36.  
 MAINE COAST SEA VEGETABLES, INC., FRANKLIN, ME:  
 3,939,641, PUB. 1-18-2011. INT. CL. 30.  
 3,939,642, PUB. 1-18-2011. INT. CL. 29.  
 MAINE ORNAMENTAL WOODWORKERS, INC., BAIN-  
 BRIDGE ISLAND, WA:  
 2,864,703, CANC. INT. CL. 6.

- MAJOR, WILLIS G., SCOTTSVILLE, NY:  
3,939,779, PUB. 1-18-2011. INT. CL. 16.
- MAKE IT WORK, INC., SANTA BARBARA, CA:  
2,461,003. REN. 2-26-11. INT. CL. 37.
- MAKO SECURITY, INC., FOREST HILLS, NY:  
3,939,373, PUB. 1-18-2011. INT. CL. 13.
- MALAWI'S PIZZA, LLC, PROVO, UT:  
3,942,176, INT. CL. 43.
- MALDONADO, ALEX, CHINO HILLS, CA:  
3,940,865, PUB. 1-18-2011. INT. CL. 35.
- MALECKI, JEFFREY, SYRACUSE, NY:  
2,865,395, CANC. INT. CL. 25.
- MAMA PRODUCTIONS, INC., AGOURA HILLS, CA:  
3,941,233, INT. CL. 41.
- MAMAS & PAPAS (HOLDINGS) LIMITED, UNITED KING-  
DOM:  
3,940,044, PUB. 1-18-2011. INT. CL. 20.
- MAMAS OF INVENTION, INC., LOS ANGELES, CA:  
2,688,537, CANC. INT. CL. 42.  
2,688,538, CANC. INT. CL. 35.
- MAMIYE BROTHERS, INC., NEW YORK, NY:  
3,942,235, INT. CL. 25.
- MANA PRODUCTS, INC., LONG ISLAND CITY, NY:  
3,941,088, INT. CL. 3.
- MANAGED CARE MEASURES, LLC, MARLTON, NJ:  
2,864,747, CANC. INT. CL. 35.
- MANCO PRODUCTS, INC., FORT WAYNE, IN:  
2,338,981, CANC. INT. CL. 12.
- MANDELL, ANDREW P., MADIERA BEACH, FL:  
2,865,148, CANC. MULTIPLE CLASS, INT. CLS. 16, 25  
AND 28.
- MANDUCA TRADING LLC, BARRINGTON, IL:  
2,865,725, CANC. INT. CL. 36.
- MANDUJAN, SALLY ANN, WEST SACRAMENTO, CA, DBA  
CHURCH OF THE CIRCLE:  
2,864,584, CANC. INT. CL. 25.
- MANLLO KURI, RICARDO JOSE, SAN PEDRO GARZA  
GARCIA, NUEVO LEON, MEXICO:  
2,864,176, CANC. INT. CL. 35.
- MANNATECH, INCORPORATED, COPPELL, TX:  
2,386,358, COR. INT. CL. 5.
- MANTISSA CORPORATION, BIRMINGHAM, AL:  
1,635,392. REN. 2-25-11. INT. CL. 9.
- MANTLE I.P. HOLDINGS, LTD, PLANO, TX:  
3,941,995, MULTIPLE CLASS, INT. CLS. 41 AND 43.
- MANUFACTURING RESOURCES INTERNATIONAL, INC.,  
ALPHARETTA, GA:  
3,941,960, INT. CL. 9.
- MANY HANDS MEDIA, INC., NEW YORK, NY:  
2,420,713. REN. 2-26-11. INT. CL. 16.
- MAPSYNC, CO., LEXINGTON, KY:  
2,439,493. REN. 2-26-11. INT. CL. 9.
- MAP18 GMBH, SWITZERLAND:  
3,939,924, PUB. 1-18-2011. INT. CL. 16.
- MARATHON EQUIPMENT COMPANY (DELAWARE), VER-  
NON, AL:  
3,941,156, INT. CL. 7.
- MARCAL PAPER MILLS, LLC, ELMWOOD PARK, NJ:  
1,634,789. REN. 3-2-11. INT. CL. 16.
- MARCA TEL COM, S.A. DE C.V., MONTERREY, MEXICO:  
2,864,743, CANC. MULTIPLE CLASS, INT. CLS. 35 AND  
38.
- MARCHIONE, DAMIAN, PLANTATION, FL:  
3,941,234, INT. CL. 42.
- MARCIA'S MUNCHIES LLC, WEST BLOOMFIELD, MI:  
3,940,353, PUB. 1-18-2011. INT. CL. 30.
- MARCON, INC., MERIDIAN, ID:  
3,941,257, INT. CL. 19.
- MARFOOD USA, INC., TAYLOR, MI:  
3,941,540, INT. CL. 29.
- MARGARET A. DAVIS, BERNARDSVILLE, NJ:  
3,940,994, INT. CL. 24.
- MARGARET M. KILBANE,, DETROIT LAKES, MN:  
3,941,889, INT. CL. 24.
- MARIE CLAIRE ALBUM, ISSY LES MOULINEAUX,  
FRANCE:  
3,939,624, PUB. 1-18-2011. INT. CL. 38.
- MARIE-LAURENCE LLC, SYOSSET, NY:  
2,864,712, CANC. INT. CL. 5.
- MARINE POLYMER TECHNOLOGIES, INC., DANVERS,  
MA:  
3,941,469, INT. CL. 10.
- MARINEPARENTS.COM, INC., COLUMBIA, MO:  
3,939,730, PUB. 1-18-2011. MULTIPLE CLASS, INT. CLS.  
16, 35, 36, 38, 41 AND 45.
- MARINER SEAFOOD MARKETING, NEW BEDFORD, MA:  
3,941,965, INT. CL. 29.
- MARITZ HOLDINGS INC., FENTON, MO:  
2,865,829, CANC. INT. CL. 35.
- MARK HEYWARD, ORLANDO, FL:  
3,939,854, PUB. 1-18-2011. INT. CL. 31.
- MARK THOMAS OLIVER, MIAMI BEACH, FL, DBA BODY  
BY YOGA:  
3,940,944, PUB. 1-18-2011. INT. CL. 25.
- MARK WINTER, MARINA DEL REY, CA:  
2,865,286, CANC. INT. CL. 9.
- MARK, STEPHANIE ELLEN, STAMFORD, CT:  
2,472,972, CANC. INT. CL. 19.
- MARKKO GMBH, BERGISCH GLADBACH, FED REP  
GERMANY:  
2,864,850, CANC. MULTIPLE CLASS, INT. CLS. 3, 24  
AND 25.
- MARLYN NUTRACEUTICALS, INC., PHOENIX, AZ, DBA  
NATURALLY VITAMINS:  
3,941,583, INT. CL. 5.
- MARQUEZ BROTHERS INTERNATIONAL, INC., SAN  
JOSE, CA:  
3,941,899, INT. CL. 30.
- MARRIOTT INTERNATIONAL, INC., BETHESDA, MD:  
3,941,970, INT. CL. 41.  
3,941,971, INT. CL. 43.
- MARS, INCORPORATED, MCLEAN, VA:  
2,864,206, CANC. INT. CL. 25.  
3,861,379, COR. INT. CL. 31.  
3,941,918, INT. CL. 30.  
3,941,919, INT. CL. 30.
- MARSHALL AMPLIFICIATION PLC, BUCKINGHAM-  
SHIRE, UNITED KINGDOM:  
3,940,239, PUB. 1-18-2011. INT. CL. 25.
- MARTHA CLARA VINEYARDS, LLC, RIVERHEAD, NY:  
3,940,634, PUB. 1-18-2011. INT. CL. 33.
- MARTHA STEWART LIVING OMNIMEDIA, INC., NEW  
YORK, NY:  
2,429,102. REN. 3-1-11. INT. CL. 42.
- MARUKAWA CONF. CO., LTD., NISHI-KU, NAGOYA,  
JAPAN:  
1,162,957. REN. 3-3-11. INT. CL. 30.
- MARY B. PALAZZO, MONMOUTH BEACH, NJ AND  
ELIZABETH B. PALAZZO, MONMOUTH BEACH, NJ  
AND KOREN K. PALAZZO-SPADAVECCHIA, MON-  
MOUTH BEACH, NJ:  
3,941,532, INT. CL. 24.
- MARYLAND STATE DEPARTMENT OF EDUCATION,  
BALTIMORE, MD:  
2,424,596, CANC. INT. CL. 41.
- MASCHINENFABRIK REINHAUSEN GMBH, FED REP  
GERMANY:  
3,939,940, PUB. 1-18-2011. MULTIPLE CLASS, INT. CLS.  
9, 37 AND 42.
- MASCO BATH CORPORATION, MOORESTOWN, NJ:  
3,941,487, INT. CL. 11.
- MASON PROPANE SERVICE LLC, EAST BERLIN, PA:  
3,942,157, INT. CL. 39.
- MAST JÄGERMEISTER AG, 38296 WOLFENBÜTTEL, FED  
REP GERMANY:  
3,940,228, PUB. 1-18-2011. MULTIPLE CLASS, INT. CLS.  
6, 9, 16, 24 AND 33.
- MAST-JÄGERMEISTER AG, 38296 WOLFENBÜTTEL, FED  
REP GERMANY:  
3,940,336, PUB. 1-18-2011. MULTIPLE CLASS, INT. CLS.  
16, 24, 25, 33 AND 41.
- MASTER HOME PRODUCTS LTD. INC., LINCOLNWOOD,  
IL, DBA MHP INTERNATIONAL LTD.:  
2,865,133, CANC. INT. CL. 10.

MASTERCARD INTERNATIONAL INCORPORATED, PURCHASE, NY:  
 2,729,633, CANC. INT. CL. 9.  
 MASTEY DE PARIS, INC., VALENCIA, CA:  
 2,437,238, REN. 3-2-11, INT. CL. 3.  
 MATCH POINT CAREERS, INC., NEW YORK, NY:  
 3,940,993, INT. CL. 42.  
 MATH 1 ON 1, LLC, STONE MOUNTAIN, GA:  
 3,940,182, PUB. 1-18-2011, INT. CL. 41.  
 MATSUO SANGYO CO., LTD., OSAKA 550-0011, JAPAN:  
 3,939,972, PUB. 1-18-2011, INT. CL. 35.  
 MATSUSHITA ELECTRIC INDUSTRIAL CO., LTD., OSAKA-FU, JAPAN:  
 2,864,464, CANC. INT. CL. 9.  
 MATT LAMB STUDIOS, CHICAGO, IL:  
 3,939,820, PUB. 1-18-2011, INT. CL. 41.  
 MATTEL, INC., EL SEGUNDO, CA:  
 2,865,510, CANC. INT. CL. 28.  
 2,865,613, CANC. INT. CL. 28.  
 2,865,640, CANC. INT. CL. 28.  
 2,865,647, CANC. INT. CL. 28.  
 2,865,650, CANC. INT. CL. 28.  
 2,865,671, CANC. INT. CL. 28.  
 2,865,672, CANC. INT. CL. 28.  
 2,865,673, CANC. INT. CL. 28.  
 3,939,785, PUB. 1-18-2011, INT. CL. 28.  
 3,941,466, INT. CL. 28.  
 MATTHEW R. KYLE, MINNEAPOLIS, MN:  
 3,941,151, MULTIPLE CLASS, INT. CLS. 9 AND 10.  
 3,941,152, MULTIPLE CLASS, INT. CLS. 9 AND 10.  
 MATTRESS FIRM, INC., HOUSTON, TX:  
 3,941,031, MULTIPLE CLASS, INT. CLS. 16, 35 AND 44.  
 MATTSON, BRIAN M., CHICAGO, IL:  
 3,942,025, INT. CL. 35.  
 MATTY, GARY A., WESTLAKE, OH, DBA SIESTA KEY CONDOS:  
 2,543,006, REN. 3-2-11, INT. CL. 36.  
 MAX TRENDS, INC., MARYSVILLE, OH:  
 2,864,056, CANC. MULTIPLE CLASS, INT. CLS. 10 AND 28.  
 MAXILL INC., ST. THOMAS, ONTARIO, CANADA, DBA MAXILL:  
 3,941,377, INT. CL. 5.  
 MAY, CECILIA W., NAPLES, FL:  
 2,863,989, CANC. INT. CL. 16.  
 MAYYA GROUP INTERNATIOANL, LLC, PROVO, UT:  
 2,865,280, CANC. INT. CL. 42.  
 MAZOOMA TECHNICAL SERVICES, INC, TORONTO, ONTARIO, CANADA:  
 3,941,742, INT. CL. 36.  
 MAZOR, ROBERT, SARASOTA, FL:  
 3,941,809, INT. CL. 28.  
 MC ENTERPRISE, L.L.C., MIAMI, FL:  
 2,864,962, CANC. INT. CL. 34.  
 MCCABE, SUSAN, CARLSBAD, CA:  
 3,882,159, AM. INT. CL. 16.  
 MCCLISH, MARK A, WINTERVILLE, NC:  
 3,939,827, PUB. 1-18-2011, INT. CL. 41.  
 MCCOMBER, KEVIN ANDREW, CAMBRIDGE, MA AND PENG, EILEEN XIAOFEI, CAMBRIDGE, MA:  
 3,940,710, PUB. 1-18-2011, INT. CL. 41.  
 MCCOY, MATTHEW, SIMI VALLEY, CA AND INTESO, GARRETT, SIMI VALLEY, CA:  
 3,942,373, INT. CL. 25.  
 MCDERMOTT CUE MFG., LLC, MENOMONEE FALLS, WI:  
 1,164,772, REN. 3-2-11, INT. CL. 28.  
 MCDERMOTT, KEVIN, HAMPSTEAD, MD:  
 2,310,835, CANC. INT. CL. 11.  
 MCDONALD, DAR-RELL, GRAND PRAIRIE, TX:  
 2,368,903, CANC. MULTIPLE CLASS, INT. CLS. 25 AND 28.  
 MCDONALD'S CORPORATION, OAK BROOK, IL:  
 1,635,845, REN. 3-2-11, INT. CL. 42.  
 1,651,838, REN. 2-26-11, INT. CL. 42.  
 1,652,698, REN. 2-26-11, INT. CL. 42.  
 MCDONALDS SANITATION SERVICES LLC, THIBODAUX, LA:  
 3,940,754, PUB. 1-18-2011, INT. CL. 44.  
 MCFERRIN, BOBBY, NEW YORK, NY:  
 1,664,472, REN. 2-25-11, INT. CL. 41.  
 MCFUTURE, INC., SEBASTIAN, FL:  
 2,464,947, REN. 2-26-11, MULTIPLE CLASS, INT. CLS. 35 AND 41.  
 MCGUIREWOODS LLP, RICHMOND, VA:  
 2,483,615, REN. 2-25-11, INT. CL. 42.  
 MCKENNA, SIOBHAN, SAN DIEGO, CA:  
 3,941,695, INT. CL. 41.  
 MCKENNEY'S, INC., ATLANTA, GA:  
 3,940,318, PUB. 1-18-2011, MULTIPLE CLASS, INT. CLS. 9, 11, 37 AND 42.  
 MCMONIGLE, JOHN, NEWPORT BEACH, CA:  
 3,940,222, PUB. 1-18-2011, INT. CL. 16.  
 MCNALLY, BRENDA, WAKEFIELD, RI:  
 3,942,088, INT. CL. 26.  
 MCNALLY, PATRICK JAMES, STOUGHTON, WI:  
 3,940,581, PUB. 1-18-2011, INT. CL. 41.  
 MCS FINANCIAL ADVISORS LLC, EUGENE, OR, DBA MCS FINANCIAL ADVISORS:  
 3,942,312, INT. CL. 36.  
 MCWILLIAMS, BRUCE, ADDISON, TX:  
 3,941,265, INT. CL. 41.  
 MDC MARKETING INC., MOORPARK, CA:  
 2,865,748, CANC. INT. CL. 34.  
 MDS HEALTH PRODUCTS LLC, ROGERS, AR:  
 3,188,033, CANC. INT. CL. 10.  
 MEANS, STEPHEN PHILIP, NORTHRIDGE, CA, DBA WISDOMGAME VIDEOS:  
 3,941,826, MULTIPLE CLASS, INT. CLS. 9, 41 AND 42.  
 MECYRUS INC, ARCADIA, CA:  
 3,941,243, INT. CL. 24.  
 MED ONE MEDICAL, L.L.C., MIDVALE, UT:  
 2,864,573, CANC. MULTIPLE CLASS, INT. CLS. 35 AND 44.  
 MEDEA RECORDS, INC., TROY, MI:  
 2,487,681, CANC. INT. CL. 9.  
 MEDECISION INC., WAYNE, PA:  
 2,490,225, REN. 3-3-11, MULTIPLE CLASS, INT. CLS. 9 AND 36.  
 MEDIA CYBERNETICS, INC., BETHESDA, MD:  
 2,429,619, REN. 3-2-11, INT. CL. 9.  
 MEDIAPLANET INTERNATIONAL AB, 100 41 STOCKHOLM, SWEDEN:  
 3,939,394, PUB. 1-18-2011, MULTIPLE CLASS, INT. CLS. 16, 35, 36, 38, 41, 42 AND 44.  
 MEDICAL ARTS PRESS, INC., BROOKLYN PARK, MN:  
 2,368,641, CANC. INT. CL. 35.  
 MEDICAL ENTERPRISES, INC., CANTON, OH, DBA LIFE CHOICE MOBILITY:  
 2,864,523, CANC. INT. CL. 35.  
 MEDICAL GRAPHICS CORPORATION, ST. PAUL, MN:  
 1,636,812, REN. 3-2-11, INT. CL. 10.  
 MEDICAL PLASTICS LABORATORY, INC., GATESVILLE, TX:  
 2,368,714, CANC. INT. CL. 28.  
 MEDIENCE CORP., SEOUL, REPUBLIC OF KOREA:  
 2,864,964, CANC. INT. CL. 5.  
 MEDISOLUTION LTD., MONTREAL, QUEBEC, CANADA:  
 2,367,575, CANC. INT. CL. 9.  
 MEDITCO, INC., HOUSTON, TX, DBA PHOENICIA SPECIALTY FOODS:  
 3,941,063, INT. CL. 29.  
 3,941,064, INT. CL. 30.  
 MEDITOUR EXPO LLC, NEW YORK, NY:  
 3,941,699, INT. CL. 44.  
 MEDIYAK, LLC, RIDGEWOOD, NJ:  
 3,941,455, MULTIPLE CLASS, INT. CLS. 35 AND 44.  
 MEDNAX SERVICES, INC., SUNRISE, FL:  
 3,942,357, INT. CL. 42.  
 MEDPEDS ASSOCIATES OF SARASOTA, SARASOTA, FL:  
 3,940,079, PUB. 1-18-2011, MULTIPLE CLASS, INT. CLS. 35 AND 44.  
 MEDTRONIC XOMED, INC., JACKSONVILLE, FL:  
 2,441,656, REN. 3-2-11, INT. CL. 10.  
 3,942,261, INT. CL. 10.  
 MEDTRONIC, INC., MINNEAPOLIS, MN:  
 3,941,364, INT. CL. 10.

- MEDWAVE, INC., ARDEN HILLS, MN:  
2,613,333, CANC. INT. CL. 10.
- MEETING PROFESSIONALS INTERNATIONAL FOUNDATION, DALLAS, TX:  
2,864,422, CANC. INT. CL. 35.
- MEGA BRANDS INTERNATIONAL, LUXEMBOURG, ZUG BRANCH, ZUG, SWITZERLAND:  
3,939,731, PUB. 1-18-2011. INT. CL. 28.
- MEGTEC SYSTEMS, INC., DE PERE, WI:  
2,435,708, REN. 2-26-11. INT. CL. 16.
- MEHDI AMINIAN, SWITZERLAND:  
3,939,976, PUB. 1-18-2011. MULTIPLE CLASS, INT. CLS. 9 AND 42.
- MEJIA, OSCAR, MIAMI, FL AND MEJIA, FABIO, MIAMI, FL:  
2,865,247, CANC. INT. CL. 37.
- MELATE, INC., LA JOLLA, CA:  
2,864,490, CANC. INT. CL. 30.
- MELLON BANK, N.A., PITTSBURGH, PA:  
2,380,090, REN. 2-26-11. INT. CL. 36.
- MEMBERTRADE FINANCIAL GROUP, LLC, ALBANY, NY:  
2,864,449, CANC. INT. CL. 35.
- MEMBRANA GMBH, D-42289 WUPPERTAL, FED REP GERMANY:  
2,438,010, REN. 2-26-11. MULTIPLE CLASS, INT. CLS. 9 AND 10.
- MEMORY SOLUTIONS, INC., MARIETTA, GA:  
2,470,281, CANC. INT. CL. 9.
- MEMPHIS BIOWORKS FOUNDATION, MEMPHIS, TN:  
3,941,997, MULTIPLE CLASS, INT. CLS. 35 AND 41.
- MENDEL ZILBERBERG AND ASSOCIATES PC, BROOKLYN, NY:  
2,865,832, CANC. MULTIPLE CLASS, INT. CLS. 36 AND 42.
- MENDLOWITZ, BENJAMIN, BROOKLIN, ME, DBA NOAH PUBLICATIONS:  
3,940,632, PUB. 1-18-2011. MULTIPLE CLASS, INT. CLS. 9 AND 16.
- MENGSHIDA SHOES CO., LTD. SHISHI CITY, FUJIAN, CHINA:  
3,939,704, PUB. 1-18-2011. INT. CL. 25.
- MENNONITE BROADCASTS, INC., HARRISONBURG, VA, DBA THIRD WAY MEDIA:  
3,940,625, PUB. 1-18-2011. INT. CL. 41.
- MENTAL ENGINEERING, INC., ST. LOUIS, MO:  
2,864,772, CANC. INT. CL. 28.
- MENZI MUCK AG, WIDNAU, SWITZERLAND, ERNST MENZI AG., CH-9443, WIDNAU, SWITZERLAND:  
909,059, REN. 2-27-11. U.S. CL. 23 (INT. CL. 7).
- MEPAL B.V., NL-7241 MB LOCHEM, NETHERLANDS:  
3,939,882, PUB. 1-18-2011. MULTIPLE CLASS, INT. CLS. 8 AND 21.
- MERCHANTS & MANUFACTURERS BANCORP, BROOKFIELD, WI:  
2,865,026, CANC. INT. CL. 36.
- MERCK SHARP & DOHME CORP., WHITEHOUSE STATION, NJ:  
3,940,965, PUB. 1-18-2011. INT. CL. 41.
- MERCKLE GMBH, D-89079 ULM, FED REP GERMANY:  
2,864,353, CANC. INT. CL. 5.
- MERHAR, RICHARD D., ROCKY RIVER, OH:  
2,368,027, CANC. INT. CL. 9.
- MERRICK PET CARE, INC., AMARILLO, TX:  
3,941,754, INT. CL. 31.
- MERRICK PET CARE, LTD., AMARILLO, TX:  
3,293,438, CANC. INT. CL. 31.
- MERRY TAILS, INC., SEATTLE, WA:  
1,646,411, REN. 3-1-11. INT. CL. 42.
- MESSER, MARGARET, NEWMAN, CA:  
3,940,746, PUB. 1-18-2011. INT. CL. 25.
- META WAREHOUSE INC., MIAMI, FL:  
2,865,143, CANC. INT. CL. 9.
- METALICO-GRANITE CITY, INC., GRANITE CITY, IL:  
1,149,746, REN. 2-26-11. INT. CL. 13.
- METHODOLOGIE, INC., SEATTLE, WA:  
2,500,669, REN. 3-3-11. INT. CL. 35.
- METRO MARKETING GROUP, INC., TENAFLY, NJ:  
3,941,818, MULTIPLE CLASS, INT. CLS. 16 AND 20.
- METROMOBILE MARKETING, INC., SAN DIEGO, CA:  
3,940,755, PUB. 1-18-2011. INT. CL. 35.
- METROPLEX SERVICES, INC., MASON, OH:  
3,942,460, INT. CL. 21.
- METROPOLITAN CHICAGO HEALTHCARE COUNCIL, CHICAGO, IL:  
3,940,097, PUB. 1-18-2011. INT. CL. 42.
- METROPOLITAN FAMILY SERVICES, CHICAGO, IL:  
2,369,278, CANC. INT. CL. 42.
- MHCS, 51200 EPERNAY, FRANCE:  
2,432,192, REN. 3-1-11. INT. CL. 33.
- MICELI, ANDREW, NEW YORK, NY:  
3,939,595, PUB. 1-18-2011. MULTIPLE CLASS, INT. CLS. 41 AND 44.
- MICHAEL A. ADAMS, TUSCON, AZ:  
3,940,477, PUB. 1-18-2011. INT. CL. 16.
- MICHAEL ANTHONY JEWELERS, INC., MOUNT VERNON, NY:  
2,865,358, CANC. INT. CL. 14.
- MICHAEL DIMARTINO, SANTA CRUZ, CA:  
3,941,371, INT. CL. 41.
- MICHAEL K. LONG, LOVELAND, CO:  
3,940,704, PUB. 1-18-2011. INT. CL. 43.
- MICHAEL MARCUS, DALLAS, TX, DBA MICHAEL MARCUS COSMETICS:  
3,940,777, PUB. 1-18-2011. INT. CL. 3.
- MICHAEL SHAUN GOODE, KENNESAW, GA:  
3,749,250, CANC. INT. CL. 30.
- MICHAEL WAINWRIGHT, INC, SAN DIEGO, CA:  
3,940,811, PUB. 1-18-2011. INT. CL. 8.  
3,940,812, PUB. 1-18-2011. INT. CL. 21.  
3,940,813, PUB. 1-18-2011. INT. CL. 20.  
3,940,814, PUB. 1-18-2011. INT. CL. 21.  
3,940,860, PUB. 1-18-2011. INT. CL. 21.
- MICHAL NEGRIN DESIGNS LTD., BAT YAM 59648, ISRAEL:  
2,864,843, CANC. MULTIPLE CLASS, INT. CLS. 18 AND 35.
- MICHELLI, RICHARD J., OCEAN, NJ:  
3,942,434, INT. CL. 41.
- MICHIGAN GAS UTILITIES CORPORATION, MONROE, MI:  
3,939,448, PUB. 1-18-2011. MULTIPLE CLASS, INT. CLS. 35, 36, 37, 39 AND 42.
- MICHIGAN INSTITUTE OF AERONAUTICS, INC., BELLEVILLE, MI:  
3,940,701, PUB. 1-18-2011. INT. CL. 41.  
3,940,702, PUB. 1-18-2011. INT. CL. 41.
- MICHIGAN XTREME CHEER, L.L.C., YPSILANTI, MI:  
2,865,322, CANC. INT. CL. 41.
- MICHIGAN 99, JACKSON, MI:  
2,864,512, CANC. INT. CL. 7.
- MICRODYN-NADIR GMBH, 65203 WIESBADEN, FED REP GERMANY:  
3,940,071, PUB. 1-18-2011. INT. CL. 11.
- MICROSEMI CORPORATION, IRVINE, CA:  
3,940,357, PUB. 1-18-2011. INT. CL. 9.
- MICROSOFT CORPORATION, REDMOND, WA:  
2,864,758, CANC. INT. CL. 9.  
2,865,608, CANC. INT. CL. 16.
- MICROTEK INTERNATIONAL INC., HSINCHU, TAIWAN 300, TAIWAN:  
2,369,101, CANC. INT. CL. 9.
- MIDTAINMENT, INC., BUENA PARK, CA:  
3,940,862, PUB. 1-18-2011. INT. CL. 35.
- MIDKIFF, DANIEL, L, WINSTON-SALEM, NC:  
3,940,190, PUB. 1-18-2011. INT. CL. 41.
- MIDLAND SPORTS, INC., MIDLAND, TX:  
2,434,766, REN. 2-26-11. INT. CL. 25.
- MIKE BURTON GROUP LIMITED, GLOUCESTER, UNITED KINGDOM:  
2,863,937, CANC. MULTIPLE CLASS, INT. CLS. 16, 35, 39, 41 AND 42.
- MIKITA COMMUNICATIONS, LLC, STATE COLLEGE, PA, DBA NEXT5 INTERACTIVE:  
2,379,239, REN. 2-26-11. INT. CL. 42.
- MIKOHN GAMING CORPORATION, LAS VEGAS, NV:  
2,369,431, CANC. INT. CL. 41.

MIKRO SYSTEMS, INC., CHARLOTTESVILLE, VA:  
3,942,082, MULTIPLE CLASS, INT. CLS. 40, 42 AND 45.

MILK MONEY CLOTHING, INC., CARSON, CA:  
3,940,695, PUB. 1-18-2011. INT. CL. 25.

MILK PRODUCTS, LLC, CHILTON, WI:  
3,942,122, INT. CL. 5.

MILLER, PETER W., AIKEN, SC:  
3,940,995, INT. CL. 36.

MILLER, RUTH ANN, COLUMBUS, OH:  
2,594,109, CANC. INT. CL. 25.

MILLER, WILLIAM B., KOANOKE, VA, DBA LEARN TO U.S.A.:  
2,368,102, CANC. INT. CL. 9.

MILLERCOORS LLC, CHICAGO, IL:  
1,656,408, REN. 3-2-11. INT. CL. 32.  
3,942,080, INT. CL. 32.  
3,942,127, INT. CL. 32.

MILLHISER-SMITH AGENCY, INC., CEDAR RAPIDS, IA:  
3,941,491, INT. CL. 36.

MILLIKEN & COMPANY, SPARTANBURG, SC, DEERING MILLIKEN, INC., NEW YORK, NY:  
908,674, REN. 2-25-11. U.S. CL. 42 (INT. CLS. 24 AND 27).

MILLIKEN & COMPANY, SPARTANBURG, SC:  
2,367,665, CANC. INT. CL. 36.

MILWAUKEE BREWERS BASEBALL CLUB, LIMITED PARTNERSHIP, MILWAUKEE, WI:  
2,384,821, COR. INT. CL. 41.  
3,941,376, INT. CL. 25.

MIMOSA S.R.L., ASOLA (MANTOVA), ITALY:  
2,864,854, CANC. MULTIPLE CLASS, INT. CLS. 10 AND 25.

MIND BODY FX WEIGHT MANAGEMENT COMPANY INC., KELOWNA, CANADA:  
3,940,246, PUB. 1-18-2011. INT. CL. 41.

MINDVOX CORPORATION, BEARVILLE, NY:  
3,939,792, PUB. 1-18-2011. INT. CL. 38.

MINEKEY, INC., SUNNYVALE, CA:  
3,941,275, INT. CL. 42.

MINNESOTA GOLF ASSOCIATION, INC., EDINA, MN:  
2,491,960, REN. 2-28-11. INT. CL. 16.

MIRACLE PRODUCTS, LLC, ROSLYN HEIGHTS, NY:  
2,553,116, CANC. INT. CL. 7.

MIRUS BIO LLC, MADISON, WI:  
3,942,196, INT. CL. 1.

MISS MONEYPENNYS BRAND LIMITED, BIRMINGHAM, WEST MIDLANDS, UNITED KINGDOM:  
2,367,904, CANC. MULTIPLE CLASS, INT. CLS. 9, 25, 35, 41 AND 42.

MISSION OF JOY, TACOMA, WA:  
2,368,291, CANC. INT. CL. 36.

MISSION PHARMACAL COMPANY, SAN ANTONIO, TX:  
3,941,201, INT. CL. 42.

MISSISSIPPI CHILDREN'S MUSEUM, JACKSON, MS:  
3,941,246, INT. CL. 41.

MITEK HOLDINGS, INC., WILMINGTON, DE:  
2,571,272, CANC. INT. CL. 17.  
2,573,415, CANC. INT. CL. 17.

MITSUBISHI ELECTRIC CORPORATION, CHIYODA-KU, TOKYO, JAPAN:  
3,939,467, PUB. 1-18-2011. INT. CL. 9.  
3,939,468, PUB. 1-18-2011. INT. CL. 9.

MITSUBISHI KAGAKU IMAGING CORPORATION, CHE-  
SAPEAKE, VA:  
3,941,994, INT. CL. 2.

MITY-LITE, INC., OREM, UT:  
2,864,661, CANC. INT. CL. 20.

MIZ LOLA'S SPIRITS & GAMING, LLC, HENDERSON, NV:  
3,941,475, MULTIPLE CLASS, INT. CLS. 41 AND 43.

MIZKAN AMERICAS, INC., MT. PROSPECT, IL, C.V. FINER FOODS, INC., WEST GARDINER, ME:  
1,641,434, REN. 3-1-11. INT. CL. 30.

MIZUNO CORPORATION, OSAKA, 541-8538, JAPAN:  
3,941,936, INT. CL. 25.

MIZUNO USA, INC., NORCROSS, GA:  
2,865,314, CANC. INT. CL. 25.

MJ SALES, INC., PEARCE, AZ:  
3,940,647, PUB. 1-18-2011. INT. CL. 9.

MJSI, INC., SHOREWOOD, IL:  
3,941,635, INT. CL. 11.

MMJ LABS, LLC, ATLANTA, GA:  
3,940,260, PUB. 1-18-2011. INT. CL. 10.

MOAC MALL HOLDINGS LLC, BLOOMINGTON, MN, DBA MALL OF AMERICA:  
3,940,177, PUB. 1-18-2011. INT. CL. 35.

MOBILE ACCORD, INC., DENVER, CO:  
3,939,618, PUB. 1-18-2011. INT. CL. 36.

MOBILE AWARENESS, SOLON, OH:  
3,939,534, PUB. 1-18-2011. INT. CL. 9.  
3,939,535, PUB. 1-18-2011. INT. CL. 9.

MOBILE STREAMS LIMITED, NEWBURY, BERKSHIRE, ENGLAND:  
2,863,940, CANC. MULTIPLE CLASS, INT. CLS. 9, 16, 35, 38 AND 41.

MOBILIZING AMERICA'S YOUTH, WASHINGTON, DC:  
3,940,189, PUB. 1-18-2011. INT. CL. 41.

MOCORE, LLC, SEATTLE, WA:  
3,939,399, PUB. 1-18-2011. INT. CL. 43.

MODELLEISENBAHN HOLDING GMBH, AUSTRIA:  
3,939,979, PUB. 1-18-2011. MULTIPLE CLASS, INT. CLS. 9, 11 AND 28.

MODERN OUTDOOR DESIGNS, LLC, CULVER CITY, CA, DBA MODERN OUTDOOR:  
3,942,337, INT. CL. 20.

MODERNICA, INC., LOS ANGELES, CA:  
3,939,483, PUB. 1-18-2011. INT. CL. 11.  
3,939,484, PUB. 1-18-2011. INT. CL. 11.

MODESAT COMMUNICATIONS OÜ, TALLINN, ESTONIA:  
3,939,909, PUB. 1-18-2011. MULTIPLE CLASS, INT. CLS. 9, 38 AND 42.

MOEN INCORPORATED, NORTH OLMSTED, OH:  
3,941,923, INT. CL. 11.

MOHAMED MAWJI, LAKE MARY, FL:  
3,940,434, PUB. 1-18-2011. INT. CL. 35.

MOHAWK CARPET DISTRIBUTION, INC., CALHOUN, GA:  
3,941,559, INT. CL. 19.  
3,941,561, INT. CL. 27.  
3,941,575, INT. CL. 27.

MOHAWK FINE PAPERS INC., COHOES, NY:  
2,369,232, CANC. INT. CL. 16.

MOHR-FRY RANCHES, LODI, CA:  
3,940,780, PUB. 1-18-2011. INT. CL. 33.  
3,940,783, PUB. 1-18-2011. INT. CL. 33.  
3,940,790, PUB. 1-18-2011. INT. CL. 31.

MOJO ASSOCIATES, LLC, SCOTTSDALE, AZ:  
3,940,859, PUB. 1-18-2011. INT. CL. 41.

MOLLERGROUP GMBH & CO. KG, BIELEFELD, FED REP GERMANY:  
2,879,960, CANC. INT. CL. 18.  
2,882,304, CANC. INT. CL. 18.

MOLONEY FAMILY FUNERAL HOMES, INC., LAKE RONKONKOMA, NY:  
3,940,733, PUB. 1-18-2011. INT. CL. 45.

MONADNOCK PAPER MILLS, INC., BENNINGTON, NH:  
727,523, REN. 3-3-11. U.S. CL. 37 (INT. CL. 16).

MONCLER S.R.L., ITALY:  
3,940,076, PUB. 1-18-2011. INT. CL. 25.

MONEY GROUP, INC., POMONA, CA:  
3,941,036, INT. CL. 36.

MONEYGRAM INTERNATIONAL, INC., MINNEAPOLIS, MN:  
2,864,883, CANC. MULTIPLE CLASS, INT. CLS. 36 AND 40.

MONSTER CABLE PRODUCTS, INC., BRISBANE, CA:  
3,941,633, INT. CL. 9.

MONSTER FISH USA, LLC, MIRAMAR, FL:  
3,941,207, INT. CL. 28.

MONSTEROPS LLC, COLORADO SPRINGS, CO:  
2,865,782, CANC. INT. CL. 5.

MONTAGE HOTELS & RESORTS, LLC, LAGUNA BEACH, CA:  
3,942,059, MULTIPLE CLASS, INT. CLS. 35, 36 AND 37.

MONTANA BOTANICAL ANALYSIS LLC, BOZEMAN, MT:  
3,940,409, PUB. 1-18-2011. INT. CL. 42.

MONTEREY GOURMET FOODS, INC., SALINAS, CA:  
2,431,420, REN. 2-26-11. INT. CL. 29.

- MONTRES MICHEL HERBELIN SA, CHARQUEMONT, FRANCE:  
1,636,105. REN. 2-28-11. INT. CL. 14.
- MOORE SR, JAMES C., OAKLAND, CA:  
3,941,141. INT. CL. 41.
- MOORES, GEOFF A., LOVELAND, OH:  
2,368,909. CANC. INT. CL. 21.
- MORAVIAN HALL SQUARE OF NAZARETH, PA, INC., NAZARETH, PA, DBA MORAVIAN HALL SQUARE:  
3,940,516. PUB. 1-18-2011. INT. CL. 44.
- MOREALIM, CHIRENS, FRANCE:  
3,939,845. PUB. 1-18-2011. MULTIPLE CLASS, INT. CLS. 29, 30 AND 31.
- MORGAN ADHESIVES COMPANY, STOW, OH:  
1,636,126. REN. 2-26-11. INT. CL. 16.
- MORGAN MADISON, LLC, ORANGE, CA:  
3,941,328. INT. CL. 5.
- MORGAN MILLER, INC., DANIA BEACH, FL:  
3,942,210. INT. CL. 25.
- MORGAN STANLEY SENIOR FUNDING, INC., AS THE ADMINISTRATIVE AGENT, NEW YORK, NY:  
2,864,485. CANC. INT. CL. 1.
- MORRIS NATIONAL, INC., AZUSA, CA:  
3,941,747. INT. CL. 30.
- MOTBN, INC., FAYETTEVILLE, GA:  
3,940,180. PUB. 1-18-2011. INT. CL. 41.
- MOTIONLX, LLC, NEWARK, DE:  
3,940,403. PUB. 1-18-2011. INT. CL. 41.  
3,940,408. PUB. 1-18-2011. INT. CL. 35.
- MOTLEY CRUE, INC., SANTA MONICA, CA:  
3,941,074. INT. CL. 9.
- MOTOR CITY RIDERS, WOLVERINE LAKE, MI:  
3,939,488. PUB. 1-18-2011. INT. CL. 41.
- MOTOROLA TRADEMARK HOLDINGS, LLC, LIBERTYVILLE, IL:  
3,941,121. MULTIPLE CLASS, INT. CLS. 9 AND 40.
- MOTORSPORT SPECIALTIES, INC., QUARRYVILLE, PA:  
1,605,434. CANC. INT. CL. 12.
- MOUNTAIN CREST SRL, MAXWELL, CHRIST CHURCH, BARBADOS:  
3,942,003. INT. CL. 32.
- MOVADO CORPORATION, WILMINGTON, DE:  
2,434,060. REN. 2-26-11. INT. CL. 14.
- MOVADO LLC, WILMINGTON, DE:  
3,940,644. PUB. 1-18-2011. INT. CL. 14.  
3,940,653. PUB. 1-18-2011. INT. CL. 14.
- MOVEX INNOVATION INC., GRAND-MÈRE, CANADA:  
3,939,425. PUB. 1-18-2011. INT. CL. 12.
- MOXYMAÜS INC., OTTAWA, ON, CANADA:  
3,941,608. INT. CL. 25.
- MPC COVE ROAD RESTAURANT, INC., STAMFORD, CT:  
3,940,926. PUB. 1-18-2011. INT. CL. 43.
- MR. GATTI'S, L.P., AUSTIN, TX, FORMERLY MR. GATTI'S, INC.:  
1,655,680. REN. 3-2-11. INT. CL. 30.
- MRB ACQUISITION CORP., PORT ORANGE, FL, DBA U-SCOOT:  
3,940,164. PUB. 1-18-2011. INT. CL. 36.
- MRB ACQUISITION CORP., PORT ORANGE, FL, DBA OPEN-AIRE:  
3,940,165. PUB. 1-18-2011. INT. CL. 36.
- MSTATION AUDIO, LLC, EL MONTE, CA:  
3,681,443. COR. INT. CL. 9.  
3,681,444. COR. INT. CL. 9.
- MT RACING INCORPORATED, TAICHUNG, TAIWAN:  
2,865,556. CANC. INT. CL. 12.
- MUDGE, ALFRED GEORGE, WASSAIC, NY:  
3,941,209. INT. CL. 41.  
3,941,210. INT. CL. 41.  
3,941,211. INT. CL. 16.  
3,941,213. INT. CL. 16.
- MUIR, MICHAEL, SAN FRANCISCO, CA:  
2,863,890. CANC. INT. CL. 9.
- MULHOLLAND, ADAM, AUGUSTA, GA:  
3,940,382. PUB. 1-18-2011. INT. CL. 14.
- MULLER FILM AND TELEVISION EDUCATION FOUNDATION, IRVING, TX:  
3,940,440. PUB. 1-18-2011. INT. CL. 41.
- MULTI MEDIA ELECTRONICS INC., FARMINGDALE, NY:  
2,865,409. CANC. INT. CL. 11.
- MULTI-CHEM GROUP, LLC, SAN ANGELO, TX:  
3,941,560. INT. CL. 1.
- MULTICORP, LLC, LAND O LAKES, FL:  
3,940,431. PUB. 1-18-2011. INT. CL. 35.
- MULTICRAFT IMPORTS INC., OTTAWA, CANADA:  
3,939,666. PUB. 1-18-2011. MULTIPLE CLASS, INT. CLS. 14 AND 16.
- MULTIMEDIA GAMES, INC., AUSTIN, TX:  
2,368,277. CANC. MULTIPLE CLASS, INT. CLS. 9, 28 AND 41.
- MURF WEAR, INC., TUSTIN, CA:  
2,864,021. CANC. INT. CL. 25.
- MUSASHI AUTO PARTS-MICHIGAN, INC., BATTLE CREEK, MI:  
2,864,840. CANC. INT. CL. 12.
- MUSCATO CORPORATION, ALTAMONTE SPRINGS, FL:  
2,367,892. CANC. MULTIPLE CLASS, INT. CLS. 9 AND 42.  
2,367,893. CANC. MULTIPLE CLASS, INT. CLS. 9 AND 42.
- MUTUAL CAPITAL ALLIANCE, INC., DALLAS, TX:  
3,942,224. INT. CL. 41.  
3,942,321. INT. CL. 41.  
3,942,322. INT. CL. 41.
- MW MANUFACTURERS, INC., ROCKY MOUNT, VA:  
2,367,605. CANC. INT. CL. 19.
- MXI CORP., RENO, NV:  
3,940,088. PUB. 1-18-2011. MULTIPLE CLASS, INT. CLS. 5, 30 AND 35.  
3,940,089. PUB. 1-18-2011. MULTIPLE CLASS, INT. CLS. 5, 32 AND 35.
- MY STYLE FILES, CHARLOTTE, NC:  
3,941,979. INT. CL. 45.
- MYMENU CANADA INC., KITCHENER, ONTARIO, CANADA:  
3,941,870. INT. CL. 29.
- MYRTLE BEACH PELICANS LP, MYRTLE BEACH, SC:  
3,940,376. PUB. 1-18-2011. INT. CL. 25.
- MYUPDATE DA, NORWAY:  
3,939,964. PUB. 1-18-2011. MULTIPLE CLASS, INT. CLS. 35, 38 AND 39.
- MÖLLER FEINMECHANIK GMBH & CO. KG, FULDA, FED REP GERMANY:  
2,864,793. CANC. INT. CL. 9.
- M2H INVESTMENTS, INC., SUMNER, WA, DBA DILLANOS COFFEE ROASTERS:  
3,940,658. PUB. 1-18-2011. INT. CL. 30.  
3,940,662. PUB. 1-18-2011. INT. CL. 30.
- M3 COSMETIC LABS LLC, HOLLY HILL, FL:  
3,941,982. INT. CL. 3.
- N.V. SUMATRA TOBACCO TRADING COMPANY, SUMATERA UTARA, INDONESIA:  
3,940,115. PUB. 1-18-2011. INT. CL. 34.
- N'LIGHTNING SOFTWARE DEVELOPMENT INC., MEDFORD, OR:  
2,864,411. CANC. INT. CL. 9.
- NABALTEC AG, 92421 SCHWANDORF, FED REP GERMANY:  
2,432,835. REN. 2-26-11. INT. CL. 1.
- NAJIT TECHNOLOGIES, INC., PORTLAND, OR:  
3,941,783. INT. CL. 5.
- NALCO COMPANY, NAPERVILLE, IL:  
2,368,625. CANC. INT. CL. 1.  
3,940,109. PUB. 1-18-2011. MULTIPLE CLASS, INT. CLS. 9 AND 35.
- NAMCO BANDAI GAMES AMERICA INC., SANTA CLARA, CA:  
3,941,680. INT. CL. 9.
- NAMCO HOLDING CORPORATION, SAN JOSE, CA:  
2,334,300. CANC. INT. CL. 9.
- NAME RITE, L.L.C., TEMECULA, CA:  
3,941,168. MULTIPLE CLASS, INT. CLS. 9, 35, 38 AND 44.
- NANOSOLUTIONS GMBH, HAMBURG, FED REP GERMANY:  
2,864,787. CANC. INT. CL. 2.



NAO ENTERPRISE, INC., OAKLAND, NJ, DBA ALPHA PROFESSIONAL TOOLS:  
2,431,013. REN. 2-25-11. INT. CL. 7.

NAPOLEON, ANDRA, LANOKA HARBOR, NJ:  
3,941,713, MULTIPLE CLASS, INT. CLS. 14, 25 AND 45.

NARDINI, KRISTY, SOLANA BEACH, CA, DBA EARTH FRIENDLY DESIGN GROUP:  
3,941,496, MULTIPLE CLASS, INT. CLS. 20 AND 21.

NATASHA MOSTERT, LONDON WIJ Q5T, UNITED KINGDOM:  
3,940,248, PUB. 1-18-2011. MULTIPLE CLASS, INT. CLS. 9, 16 AND 41.  
3,940,249, PUB. 1-18-2011. MULTIPLE CLASS, INT. CLS. 9, 16 AND 41.

NATASHA MOSTERT, LONDON WIJ Q5T, ENGLAND:  
3,940,250, PUB. 1-18-2011. MULTIPLE CLASS, INT. CLS. 9, 16 AND 41.  
3,940,251, PUB. 1-18-2011. MULTIPLE CLASS, INT. CLS. 9, 16 AND 41.  
3,940,252, PUB. 1-18-2011. MULTIPLE CLASS, INT. CLS. 9, 16 AND 41.

NATHAN AMAR, LOS ANGELES, CA:  
3,939,706, PUB. 1-18-2011. INT. CL. 25.

NATIONAL ARBITRATION AND MEDIATION, INC., GARDEN CITY, NY:  
2,368,526, CANC. INT. CL. 42.

NATIONAL ASSOCIATION FOR STOCK CAR AUTO RACING, INC., DAYTONA BEACH, FL:  
3,940,121, PUB. 1-18-2011. INT. CL. 41.

NATIONAL ASSOCIATION OF BOARDS OF PHARMACY, MOUNT PROSPECT, IL:  
3,941,301, U.S. CL. B.

NATIONAL ASSOCIATION OF MUSIC MERCHANTS, INC., CARLSBAD, CA:  
3,941,427, INT. CL. 35.

NATIONAL ASSOCIATION OF RECORDING MERCHANTS, INC., MARLTON, NJ:  
2,368,153, CANC. U.S. CL. 200.  
2,368,154, CANC. U.S. CL. 200.

NATIONAL CENTER FOR PREVENTION AND RESEARCH SOLUTIONS, INC., DAYTONA BEACH, FL:  
3,942,299, MULTIPLE CLASS, INT. CLS. 35 AND 41.

NATIONAL CITY BANK, CLEVELAND, OH:  
2,864,210, CANC. MULTIPLE CLASS, INT. CLS. 40 AND 42.

NATIONAL COAL CORPORATION, KNOXVILLE, TN:  
2,864,645, CANC. INT. CL. 37.

NATIONAL COUNCIL FOR ACCREDITATION OF TEACHER EDUCATION, WASHINGTON, DC:  
2,527,216. REN. 2-26-11. MULTIPLE CLASS, INT. CLS. 16 AND 41.

NATIONAL DATACARE CORPORATION, CHANTILLY, VA:  
3,052,246, CANC. INT. CL. 9.

NATIONAL DISTRIBUTION WAREHOUSE, INC., BROOKLYN, NY:  
3,941,776, INT. CL. 9.

NATIONAL FIRE SAFETY COUNCIL, MICHIGAN CENTER, MI:  
2,527,005. REN. 2-26-11. INT. CL. 42.

NATIONAL FLEET SERVICES, LLC, CUMMING, GA:  
3,940,092, PUB. 1-18-2011. INT. CL. 35.

NATIONAL FOOTBALL LEAGUE, NEW YORK, NY:  
2,369,187, CANC. INT. CL. 41.

NATIONAL GYPSUM PROPERTIES, LLC, CHARLOTTE, NC, 9070-3752 QUEBEC INC., MONTREAL, CANADA:  
2,432,528. REN. 3-2-11. INT. CL. 19.

NATIONAL HEALTH INFORMATION NETWORK, INC., FORT WORTH, TX:  
2,437,335. REN. 2-25-11. INT. CL. 42.

NATIONAL HOUSEWARES MANUFACTURERS ASSOCIATION, ROSEMONT, IL:  
2,541,762. REN. 2-26-11. INT. CL. 42.

NATIONAL ICE EXCHANGE, LLC, DALLAS, TX:  
2,864,677, CANC. INT. CL. 35.

NATIONAL INDUSTRIES FOR THE BLIND, ALEXANDRIA, VA:  
2,470,095. REN. 3-2-11. INT. CL. 35.

NATIONAL LOGISTICS MANAGEMENT CO., DETROIT, MI:  
3,941,050, MULTIPLE CLASS, INT. CLS. 35 AND 42.

NATIONAL MARROW DONOR PROGRAM, MINNEAPOLIS, MN:  
3,942,211, INT. CL. 41.

NATIONAL MUSEUM OF WOMEN IN THE ARTS, THE, WASHINGTON, DC:  
2,429,197. REN. 2-25-11. U.S. CL. 200.

NATIONAL MUSIC PUBLISHERS' ASSOCIATION, INC., WASHINGTON, DC:  
2,426,392. REN. 2-25-11. INT. CL. 16.

NATIONAL NUTRITION, INC., LANCASTER, PA:  
2,540,632. REN. 3-3-11. INT. CL. 5.

NATIONAL ORGANIZATION OF PATRIOTIC AMERICAN BUSINESSES INC., PALM HARBOR, FL:  
3,940,108, PUB. 1-18-2011. INT. CL. 35.

NATIONAL OVARIAN CANCER COALITION, INC., DALLAS, TX:  
3,939,443, PUB. 1-18-2011. MULTIPLE CLASS, INT. CLS. 35, 44 AND 45.  
3,939,444, PUB. 1-18-2011. MULTIPLE CLASS, INT. CLS. 35, 44 AND 45.  
3,939,445, PUB. 1-18-2011. MULTIPLE CLASS, INT. CLS. 35, 44 AND 45.

NATIONAL POLYTECHNIC COLLEGE, INC., COMMERCE, CA:  
3,940,546, PUB. 1-18-2011. INT. CL. 41.

NATIONAL PSORIASIS FOUNDATION, PORTLAND, OR:  
3,941,021, INT. CL. 39.

NATIONAL PUBLISHING AND TECHNOLOGY, INC., BONITA SPRINGS, FL:  
3,942,343, MULTIPLE CLASS, INT. CLS. 9 AND 41.

NATIONAL RIFLE ASSOCIATION OF AMERICA, FAIRFAX, VA:  
3,940,902, PUB. 1-18-2011. INT. CL. 35.

NATIONAL SHOOTING SPORTS FOUNDATION, INC., NEWTOWN, CT:  
2,865,837, CANC. INT. CL. 35.

NATIONAL SKEET SHOOTING ASSOCIATION, SAN ANTONIO, TX:  
2,865,171, CANC. MULTIPLE CLASS, INT. CLS. 35 AND 41.

NATIONAL SPEAKERS ASSOCIATION, TEMPE, AZ:  
2,367,885, CANC. U.S. CL. 200.

NATIONAL STAFF DEVELOPMENT COUNCIL, OXFORD, OH:  
3,941,525, MULTIPLE CLASS, INT. CLS. 9, 16 AND 41.

NATIONAL STEELCRAFTERS OF TEXAS, LLC, ARLINGTON, TX:  
3,940,303, PUB. 1-18-2011. INT. CL. 11.

NATIONAL WHOLESALE COMPANY, INC., LEXINGTON, NC:  
3,939,636, PUB. 1-18-2011. INT. CL. 25.

NATIONSRENT WEST, INC., SACRAMENTO, CA TO SUNBELT RENTALS, INC., FORT MILL, SC:  
2,367,538, CANC. MULTIPLE CLASS, INT. CLS. 35 AND 37.

NATIONWIDE MUTUAL INSURANCE COMPANY, COLUMBUS, OH:  
3,941,218, INT. CL. 36.

NATIONWIDE STUDIOS, GALLATIN, TN:  
3,940,099, PUB. 1-18-2011. INT. CL. 41.

NATR, INC., EUREKA, CA:  
2,865,421, CANC. INT. CL. 5.

NATURAL AWAKENINGS PUBLISHING CORPORATION, NAPLES, FL, AKA NATURAL AWAKENINGS:  
3,939,545, PUB. 1-18-2011. INT. CL. 16.

NATURAL BODY INC., OZONE PARK, NY:  
3,940,551, PUB. 1-18-2011. INT. CL. 35.

NATURAL HIGH AUSTRALIA PTY. LIMITED, NEW SOUTH WALES 2250, AUSTRALIA:  
2,864,002, CANC. INT. CL. 30.

NATURAL ORGANICS INC., MELVILLE, NY:  
2,473,232. REN. 2-25-11. INT. CL. 5.  
2,493,445. REN. 2-25-11. INT. CL. 5.  
2,494,703. REN. 2-25-11. INT. CL. 5.

- NATURE'S PATH LLC, BROOKLYN, NY:  
2,865,689, CANC. INT. CL. 5.
- NATURE'S SUNSHINE PRODUCTS, INC., PROVO, UT:  
2,864,359, CANC. INT. CL. 5.
- NATURIFE BRANDS, LLC, SALINAS, CA:  
3,942,005, MULTIPLE CLASS, INT. CLS. 29 AND 31.
- NAUTIC GLOBAL GROUP, INC., ELKHART, IN:  
2,367,651, CANC. INT. CL. 12.
- NAVY MUTUAL AID ASSOCIATION, ARLINGTON, VA:  
2,367,636, CANC. INT. CL. 42.
- NC-02, INC., NEW YORK, NY:  
3,941,847, INT. CL. 25.
- NCMIC GROUP, INC., WEST DES MOINES, IA:  
2,865,830, CANC. MULTIPLE CLASS, INT. CLS. 41 AND 42.
- NCN INTERSTATE DISTRIBUTORS INC., MAHWAH, NJ:  
2,865,848, CANC. INT. CL. 16.
- NCR CORPORATION, DAYTON, OH:  
2,368,953, CANC. MULTIPLE CLASS, INT. CLS. 9 AND 42.
- NCR CORPORATION, DULUTH, GA:  
2,391,796, REN. 2-28-11, MULTIPLE CLASS, INT. CLS. 37 AND 42.
- NE FOODS INC., NORTH EAST, PA:  
2,209,096, CANC. INT. CL. 36.
- NEAL AND ASSOCIATES BUSINESS CONSULTANTS, INC., PHOENIX, AZ:  
3,940,384, PUB. 1-18-2011, INT. CL. 41.
- NEETAN MANDALIA, ALAMOGORDO, NM:  
3,941,462, INT. CL. 26.
- NEILMED PRODUCTS, INC., SANTA ROSA, CA:  
3,942,295, INT. CL. 5.
- NELARUSKY LLC, CHICAGO, IL, FORMERLY MCFEST LLC:  
3,940,672, PUB. 1-18-2011, INT. CL. 41.
- NELLCOR PURITAN BENNETT LLC, BOULDER, CO:  
2,436,055, REN. 3-2-11, INT. CL. 10.  
2,443,030, REN. 2-26-11, INT. CL. 10.
- NEMECO, PARIS, FRANCE:  
3,939,968, PUB. 1-18-2011, INT. CL. 32.
- NEMOTO KYORINDO CO., LTD., TOKYO, JAPAN:  
2,864,755, CANC. INT. CL. 10.
- NEODIO TECHNOLOGIES CORPORATION, CHUNG-HO, TAIPEI HSIEN, TAIWAN:  
2,864,488, CANC. INT. CL. 9.
- NEOPOST USA INC., MILFORD, CT:  
3,942,424, INT. CL. 9.
- NEPTUNE MANAGEMENT CORP., PLANTATION, NY:  
3,941,373, INT. CL. 45.
- NEPTUNE MANAGEMENT CORP., PLANTATION, FL:  
3,941,374, INT. CL. 45.
- NERVANA, INC., BELLEVUE, WA, DBA NERVANA, INC.:  
2,865,424, CANC. INT. CL. 9.
- NESCHEN AMERICAS CORPORATION, ELKRIDGE, MD:  
2,519,184, REN. 2-25-11, INT. CL. 17.
- NESTOR DANIEL HOYER, DOWNEY, CA, DBA LOS TERRICOLAS:  
3,940,184, PUB. 1-18-2011, INT. CL. 41.
- NET WORTH MEDIA, LLC, JUPITER, FL:  
3,942,190, INT. CL. 28.
- NETGAIN CORPORATION, KNOXVILLE, TN:  
3,939,585, PUB. 1-18-2011, INT. CL. 9.
- NETLOGIC MICROSYSTEMS, INC., MOUNTAIN VIEW, CA:  
2,865,549, CANC. INT. CL. 9.
- NETRO CITY DESIGN AND INFORMATION SYSTEMS, INC., MANCHESTER, NH:  
2,367,966, CANC. INT. CL. 42.
- NETWORK LEARNING INSTITUTE, INC., MOUNT LAUREL, NJ, DBA GEEX COMPUTER SERVICES:  
3,940,154, PUB. 10-12-2010, MULTIPLE CLASS, INT. CLS. 37 AND 42.
- NETWORK OF INDIAN PROFESSIONALS OF NORTH AMERICA, INC., SOUTH PLAINFIELD, NJ:  
3,939,614, PUB. 1-18-2011, INT. CL. 41.
- NETWORK OPTIONS, INC., FORT COLLINS, CO:  
3,311,930, CANC. INT. CL. 35.
- NEUDESIC, LLC, IRVINE, CA:  
3,940,589, PUB. 1-18-2011, INT. CL. 42.  
3,940,590, PUB. 1-18-2011, INT. CL. 35.  
3,940,970, PUB. 1-18-2011, INT. CL. 35.
- NEUEDGE, LLC, MAGEE, MS:  
3,941,913, INT. CL. 16.
- NEUSCHELER, MICHAEL, HARRISON, NY:  
3,940,660, PUB. 1-18-2011, INT. CL. 44.  
3,940,692, PUB. 1-18-2011, INT. CL. 44.
- NEUTROGENA CORPORATION, LOS ANGELES, CA:  
2,450,265, REN. 3-3-11, INT. CL. 3.
- NEW DESIGNS FOR COMFORT, INC., NEEDHAM, MA:  
3,942,163, INT. CL. 20.  
3,942,164, INT. CL. 20.
- NEW HORIZONS MARKETING GROUP, LLC, PRIOR LAKE, MN, DBA NEW HORIZON COMMUNICATIONS:  
2,865,826, CANC. INT. CL. 42.
- NEW JERSEY SOCIETY OF OPTOMETRIC PHYSICIANS, LAWRENCEVILLE, NJ:  
2,368,171, CANC. INT. CL. 42.
- NEW PENDULUM CORP., WILMINGTON, DE:  
3,942,229, INT. CL. 16.
- NEW SKIES SATELLITES B.V., THE HAGUE, NETHERLANDS:  
2,429,988, REN. 2-26-11, INT. CL. 38.
- NEW SYMRNA WORKSHOP, INC., VALLEY, AL:  
3,940,805, PUB. 1-18-2011, INT. CL. 37.
- NEW YORK MEDIA, LLC, NEW YORK, NY:  
3,939,753, PUB. 1-18-2011, INT. CL. 16.  
3,939,754, PUB. 1-18-2011, INT. CL. 16.  
3,939,758, PUB. 1-18-2011, INT. CL. 16.
- NEW YORK SOUND ROOM, INC., NEW YORK, NY:  
2,865,099, CANC. MULTIPLE CLASS, INT. CLS. 35 AND 41.
- NEW YORK YACHT CLUB, NEW YORK, NY:  
3,939,567, PUB. 1-18-2011, MULTIPLE CLASS, INT. CLS. 24, 41 AND 43.
- NEW YORK YANKEES PARTNERSHIP, BRONX, NY:  
2,368,952, CANC. MULTIPLE CLASS, INT. CLS. 16 AND 25.
- NEW ZANGO, HEWITT, TX:  
3,940,413, PUB. 1-18-2011, INT. CL. 43.
- NEWTECH INDUSTRIAL CORPORATION, EDEN PRAIRIE, MN:  
2,865,066, CANC. INT. CL. 10.
- NEWVIEW TECHNOLOGIES INC., NEW YORK, NY:  
2,865,788, CANC. INT. CL. 42.
- NEXEN TIRE CORPORATION, KYONGSANGNAM-DO, REPUBLIC OF KOREA:  
2,445,226, REN. 3-3-11, INT. CL. 12.
- NEXTERA ENERGY, INC., JUNO BEACH, FL:  
3,942,016, INT. CL. 35.
- NEXTLABS, INC., SAN MATEO, CA:  
3,942,107, INT. CL. 9.
- NEXTOY, LLC, CHAPPAQUA, NY:  
3,941,027, MULTIPLE CLASS, INT. CLS. 9, 16 AND 41.
- NEXTWAVE, INC., TROY, MI:  
3,940,591, PUB. 1-18-2011, MULTIPLE CLASS, INT. CLS. 35 AND 36.
- NICE HOUSE PRODUCTIONS, INC., LOS ANGELES, CA:  
2,864,952, CANC. INT. CL. 16.
- NICENE BRANDS I, LLC, ST. LOUIS, MO, PROCTER & GAMBLE COMPANY, THE, CINCINNATI, OH:  
539,215, REN. 3-3-11, U.S. CL. 44 (INT. CLS. 5, 8, 10 AND 12).
- NICHOLAS BROWN, UNITED KINGDOM:  
3,940,009, PUB. 1-18-2011, MULTIPLE CLASS, INT. CLS. 1, 3, 24 AND 25.
- NICKLAS ASSOCIATES, INC., BETHESDA, MD:  
3,940,198, PUB. 1-18-2011, MULTIPLE CLASS, INT. CLS. 35 AND 41.
- NICKLAUS COMPANIES, LLC, NORTH PALM BEACH, FL:  
1,635,584, REN. 2-25-11, INT. CL. 28.  
3,941,621, INT. CL. 33.
- NICOLE LAUREN LLC, HUNTINGTON, NY:  
3,940,618, PUB. 1-18-2011, INT. CL. 35.

NICOLETTE INDUSTRIES, INC., INDIANAPOLIS, IN, DBA MODERN WA SOAP COMPANY:  
2,367,689, CANC. INT. CL. 3.

NIELSEN MEDIA RESEARCH, INC., NEW YORK, NY:  
2,367,336, CANC. INT. CL. 16.

NII NORTHERN INTERNATIONAL INC., COQUITLAM, BC, CANADA:  
3,941,067, INT. CL. 11.

NINGBO SHINN YIH STATIONERY CO., LTD., NINGBO, CHINA:  
2,478,063, REN. 2-25-11. INT. CL. 16.

NINTENDO OF AMERICA INC., REDMOND, WA:  
2,382,993, AM. INT. CL. 41.  
3,891,744, COR. INT. CL. 18.

NIP GROUP, INC., WOODBRIDGE, NJ:  
3,942,189, INT. CL. 36.

NISCAYAH, INC., DULUTH, GA:  
2,368,989, CANC. INT. CL. 6.

NISIM, RODICA, BEVERLY HILLS, CA:  
2,864,580, CANC. INT. CL. 36.  
2,864,581, CANC. INT. CL. 36.

NISUS CORPORATION, ROCKFORD, TN:  
3,941,841, INT. CL. 5.

NITTANY CORPORATION, WILMINGTON, DE, COASTAL FOODS CO., INC., CAMBRIDGE, MD:  
925,200, REN. 3-1-11. U.S. CL. 46 (INT. CL. 29).

NITTO KOHKI COMPANY, LIMITED, OHTA-KU, TOKYO, JAPAN:  
910,009, REN. 3-2-11. U.S. CL. 23 (INT. CL. 7).

NKN LTD., 577-0007, JAPAN:  
2,430,922, REN. 3-2-11. INT. CL. 12.

NM NEVADA TRUST, LAS VEGAS, NV:  
2,404,570, CANC. INT. CL. 25.

NMTC, INC., STOW, OH, DBA MATCO TOOLS:  
1,147,518, REN. 2-25-11. INT. CL. 8.

NOBELCOM, LLC, CARLSBAD, CA:  
3,940,443, PUB. 1-18-2011. INT. CL. 16.

NOBLE APPAREL, INC., LOS ANGELES, CA:  
2,865,735, CANC. INT. CL. 25.

NOEMDOE, GERALD, SAN FRANCISCO, CA:  
3,940,518, PUB. 1-18-2011. INT. CL. 35.

NOLL, MARK, COCONUT CREEK, FL:  
3,941,692, INT. CL. 35.

NOMACO, INC., ZEBULON, NC:  
1,147,662, REN. 2-27-11. INT. CL. 17.

NORDIC ENTRY NETWORK AB, SWEDEN:  
3,939,911, PUB. 1-18-2011. MULTIPLE CLASS, INT. CLS. 6, 17 AND 19.

NORFORD, DAVID, KING GEORGE, VA:  
2,489,694, REN. 3-1-11. INT. CL. 35.

NORMARK CORPORATION, MINNETONKA, MN, NORMARK CORPORATION, MINNEAPOLIS, MN:  
1,636,996, REN. 2-26-11. INT. CL. 28.

NORSE DAIRY SYSTEMS, LLC, RICHMOND, VA:  
803,183, CANC. U.S. CL. 46.

NORSEMEN PRODUCTIONS, INC., SHERMAN OAKS, CA:  
2,648,149, CANC. INT. CL. 41.

NORTH AMERICAN PUBLISHING COMPANY, PHILADELPHIA, PA:  
2,367,317, CANC. INT. CL. 16.

NORTH COAST PROFESSIONAL SPORTS, LTD., WARRENSVILLE HEIGHTS, OH:  
2,864,529, CANC. INT. CL. 41.

NORTHERN ILLINOIS STEEL SUPPLY CO., CHANNAHON, IL:  
2,537,000, REN. 2-26-11. MULTIPLE CLASS, INT. CLS. 35 AND 40.

NORTHERN SAFETY CO., INC., FRANKFORT, NY:  
3,942,243, INT. CL. 9.  
3,942,257, INT. CL. 16.

NORTHLICH, INC., CINCINNATI, OH:  
2,865,814, CANC. INT. CL. 35.

NORTHSHORE GLOBAL HOLDINGS, LLC, BROOKLYN, NY:  
3,939,770, PUB. 1-18-2011. INT. CL. 41.

NORTHWESTERN CORPORATION, SIOUX FALLS, SD, DBA NORTHWESTERN ENERGY:  
3,942,454, INT. CL. 35.

NORTHWESTERN UNIVERSITY, EVANSTON, IL:  
3,939,790, PUB. 1-18-2011. INT. CL. 41.

NORTON, WILLARD S., KANSAS CITY, MO:  
2,864,684, CANC. INT. CL. 6.

NOTEWORTHY CO., THE, AMSTERDAM, NY:  
1,631,659, REN. 2-26-11. INT. CL. 22.

NOTIFYMD, INC., FRANKLIN, TN, NOTIFYMD, INC., FRANKLIN, TN:  
2,436,018, REN. 2-26-11. INT. CL. 38.

NOUVEAU EYEWEAR, INC., CARROLLTON, TX:  
3,941,330, INT. CL. 9.

NOUVEL AG, TRIENGEN, CH-6234 TRIENGEN, SWITZERLAND:  
3,939,903, PUB. 1-18-2011. MULTIPLE CLASS, INT. CLS. 8, 11 AND 21.

NOVA CHEESE INC., ORANGEVILLE, ONTARIO, CANADA:  
2,424,732, REN. 2-25-11. INT. CL. 29.

NOVARTIS AG, BASEL, SWITZERLAND:  
696,323, CANC. U.S. CL. 18.  
893,563, CANC. U.S. CL. 18.  
2,864,732, CANC. INT. CL. 5.  
2,864,737, CANC. INT. CL. 5.  
2,864,968, CANC. INT. CL. 5.

NOVELS, KEITH, CARY, NC:  
2,864,589, CANC. INT. CL. 41.

NOVO NORDISK A/S, 2880 BAGSVAERD, DENMARK, NOVO-NORDISK A/S, BAGSVAERD, DENMARK:  
1,637,355, REN. 3-2-11. MULTIPLE CLASS, INT. CLS. 5 AND 10.

NOVO NORDISK A/S, DENMARK:  
3,939,885, PUB. 1-18-2011. INT. CL. 41.

NOVO NORDISK A/S, DK-2880 BAGSVAERD, DENMARK:  
3,940,070, PUB. 1-18-2011. INT. CL. 10.

NOVODYNAMICS, INC., ANN ARBOR, MI:  
2,395,173, REN. 2-26-11. INT. CL. 9.

NOVOZYMES A/S, BAGSVAERD, DENMARK:  
3,939,670, PUB. 1-18-2011. INT. CL. 1.

NOWICKI, FRANK, BRAINERD, MN:  
3,939,744, PUB. 1-18-2011. INT. CL. 30.

NOXELL CORPORATION, HUNT VALLEY, MD:  
3,941,267, INT. CL. 3.

NPG OF OREGON, INC., ST. JOSEPH, MO:  
2,367,757, CANC. INT. CL. 38.

NRG ENERGY, INC., PRINCETON, NJ:  
3,940,229, PUB. 1-18-2011. MULTIPLE CLASS, INT. CLS. 37 AND 40.  
3,940,500, PUB. 1-18-2011. INT. CL. 36.

NSC PARTNERS LLC, LAHAINA, HI:  
3,942,250, INT. CL. 41.

NUCH INCORPORATION, PLANT CITY, FL:  
2,864,452, CANC. INT. CL. 25.

NUFARM AMERICAS INC., BURR RIDGE, IL:  
2,451,842, REN. 2-25-11. INT. CL. 5.  
3,941,850, INT. CL. 5.

NUGEN TECHNOLOGIES, INC., SAN CARLOS, CA:  
3,941,139, INT. CL. 5.  
3,941,663, INT. CL. 5.  
3,941,744, INT. CL. 5.

NUGENIX LLC, BERWYN, PA:  
2,864,209, CANC. INT. CL. 44.

NULAIID FOODS, INC., RIPON, CA:  
2,501,751, REN. 3-2-11. INT. CL. 29.

NUMESA, INC., ADDISON, TX:  
2,865,460, CANC. INT. CL. 9.

NURELM, INC., UNIONTOWN, PA:  
2,864,967, CANC. INT. CL. 9.

NURTURED PETS, LLC, NEW PHILADELPHIA, OH:  
3,941,124, INT. CL. 5.

NUTECH FIRE & SECURITY, MAITLAND, FL:  
3,940,174, PUB. 1-18-2011. MULTIPLE CLASS, INT. CLS. 37, 42 AND 45.

NUTEK CUSTOM HOSIERY, INCORPORATED, HICKORY, NC:  
2,621,612, CANC. INT. CL. 25.

NUTRACUT LLC, MIAMI, FL:  
3,332,188, CANC. INT. CL. 5.

- NUTRAMARKS, INC., PARK CITY, UT:  
2,865,098, CANC. INT. CL. 3.
- NUTRI PHARMA ASA, N-0160 OSLO, NORWAY:  
2,863,891, CANC. INT. CL. 5.
- NUTRI-HEALTH SUPPLEMENTS, LLC, COTTONWOOD, AZ:  
3,940,623, PUB. 1-18-2011. INT. CL. 35.  
3,941,840, INT. CL. 5.
- NUVASIVE, INC., SAN DIEGO, CA:  
3,941,134, INT. CL. 10.
- NUVERB SYSTEMS INC., NORTH YORK, ONTARIO, CANADA:  
2,415,349, REN. 2-25-11. INT. CL. 9.
- NZN INTERNATIONAL LICENSING PTY LIMITED, NORTH SYDNEY, AUSTRALIA:  
3,939,870, PUB. 1-18-2011. MULTIPLE CLASS, INT. CLS. 29, 30 AND 35.
- O'BIOLLA CORPORATION, KIRKLAND, WA:  
3,940,334, PUB. 1-18-2011. INT. CL. 32.
- O'HARE RECORDS RETENTION CENTER INCORPORATED, CHICAGO, IL:  
2,368,090, CANC. INT. CL. 39.
- OAKLEY, INC., FOOTHILL RANCH, CA:  
3,941,018, INT. CL. 9.
- OBEROI HOTELS PVT. LIMITED, KOLKATA, INDIA:  
3,940,661, PUB. 1-18-2011. MULTIPLE CLASS, INT. CLS. 41, 43 AND 44.
- OBSHCHESTVO S OGRANICHENNOI; OTVETSTVENNOSTIU "EKSITOM", RUSSIAN FED.:  
3,939,908, PUB. 1-18-2011. MULTIPLE CLASS, INT. CLS. 25 AND 35.
- OBSHCHESTVO S OGRANICHENNOY; OTVETSTVENNOST'YU; "BABKINY SEMECHKI", RUSSIAN FED.:  
3,939,928, PUB. 6-15-2010. MULTIPLE CLASS, INT. CLS. 16, 29, 30 AND 35.
- OBSHCHESTVO S OGRANICHENNOY; OTVETSTVENNOSTYU; "MEBELNAYA FABRIKA MARIYA"; (MARIYA FURNITURE FACTORY LTD), RUSSIAN FED.:  
3,940,015, PUB. 1-18-2011. MULTIPLE CLASS, INT. CLS. 20 AND 35.
- OCC, INC., MOUNTLAKE TERRACE, WA:  
2,864,173, CANC. INT. CL. 41.
- OCEAN DUKE CORPORATION, TORRANCE, CA:  
2,502,969, REN. 2-26-11. INT. CL. 29.
- OCEANEERING INTERNATIONAL, INC., HOUSTON, TX:  
1,178,644, REN. 2-27-11. INT. CL. 42.
- OCTALEAN, LLC, VERMILION, OH:  
3,942,183, INT. CL. 5.
- OESCH, JACKIE, SANTA ANA, CA:  
2,865,821, CANC. INT. CL. 20.
- OHIO BROACH & MACHINE COMPANY, THE, WILLOUGHBY, OH:  
1,186,445, REN. 2-25-11. INT. CL. 7.
- OIL-DRI CORPORATION OF AMERICA, CHICAGO, IL:  
2,572,918, CANC. INT. CL. 3.
- OKIYA GROUP CO., LTD, CHINA:  
3,939,970, PUB. 1-18-2011. INT. CL. 7.
- OKWAVE, TOKYO, JAPAN:  
3,940,685, PUB. 1-18-2011. MULTIPLE CLASS, INT. CLS. 38 AND 42.
- OLD ORCHARD EQUITY CORP., SPARTA, MI AND OLD ORCHARD BRANDS LLC, SPARTA, MI:  
2,865,124, CANC. INT. CL. 32.
- OLD STATS LLC, MORTON GROVE, IL:  
2,377,615, REN. 2-26-11. INT. CL. 41.
- OLDCASTLE BUILDINGENVELOPE, INC., PLANO, TX:  
3,942,110, INT. CL. 42.
- OLDMAN, MARK, NEW YORK, NY, DBA WETAKEM, LLC:  
3,940,270, PUB. 1-18-2011. INT. CL. 41.
- OLE SMOKY CANDY KITCHEN, INC., GATLINBURG, TN:  
720,401, REN. 3-2-11. U.S. CL. 46 (INT. CLS. 1, 5, 29, 30, 31 AND 32).
- OLEOQUIVIR, S.A., UTRERA, SEVILLE, SPAIN:  
2,865,525, CANC. INT. CL. 3.
- OLIMP LABORATORIES SP. Z O.O., POLAND:  
3,939,935, PUB. 1-18-2011. MULTIPLE CLASS, INT. CLS. 29 AND 30.
- OLIVEIRA, LUIS FERREIRA, NORTON, MA:  
3,941,032, INT. CL. 33.
- OLYMPIA GROUP, INC., CITY OF INDUSTRY, CA:  
2,736,990, CANC. INT. CL. 8.
- OMAT LTD., JERUSALEM 91341, ISRAEL:  
2,367,640, CANC. INT. CL. 9.
- OMD USA LLC, NEW YORK, NY:  
2,431,908, REN. 2-26-11. INT. CL. 35.
- OMEGA ENGINEERING, INC., STAMFORD, CT:  
1,636,008, REN. 3-3-11. INT. CL. 9.  
1,636,009, REN. 3-3-11. INT. CL. 9.
- OMNI ACQUISITION CORP., MOORESTOWN, NJ, DBA OMNIMED, INC.:  
3,939,482, PUB. 1-18-2011. INT. CL. 10.
- OMNI CONTAINMENT SYSTEMS, LLC., CARY, IL:  
3,939,847, PUB. 1-18-2011. INT. CL. 6.
- OMNICOM MEDIA GROUP HOLDINGS INC., NEW YORK, NY:  
3,942,296, INT. CL. 35.
- OMNIPHARM LIMITED, NOTTINGHAM, UNITED KINGDOM:  
3,939,626, PUB. 1-18-2011. INT. CL. 5.
- ON THE GO WELLNESS, HICKMAN, NE:  
3,941,146, INT. CL. 44.
- ON THE ROCKS PRODUCTIONS LLC, RYE, NH:  
3,939,638, PUB. 1-18-2011. INT. CL. 16.
- ON TOP RESULTS INC., WAXHAW, NC:  
3,939,765, PUB. 1-18-2011. INT. CL. 35.
- ONBEST TECHNOLOGY HOLDINGS LIMITED, HONG KONG, HONG KONG:  
3,941,430, INT. CL. 36.
- ONCE OPENED, LLC, COXSACKIE, NY:  
3,941,215, INT. CL. 16.
- ONE SQUARE, INC., DALLAS, TX, DBA SQUARE ONE:  
2,863,997, CANC. INT. CL. 35.
- ONE WORLD ACCESS, MALIBU, CA:  
3,941,806, INT. CL. 25.
- ONE-EYED DOLL, AUSTIN, TX:  
3,940,696, PUB. 1-18-2011. INT. CL. 41.
- ONESHARE INVESTMENTS, LLC, SAN FRANCISCO, CA, DBA COLLEGE ROCKET:  
3,940,886, PUB. 1-18-2011. INT. CL. 36.
- ONESTOP INC., TERRYVILLE, CT:  
3,941,861, INT. CL. 8.
- ONSTREAM MEDIA CORPORATION, POMPAÑO BEACH, FL:  
3,939,798, PUB. 1-18-2011. INT. CL. 42.
- OPEN CHANNEL SOLUTIONS, INC., NORWOOD, MA:  
2,368,381, CANC. INT. CL. 35.
- OPEN JOINT STOCK COMPANY; "RUSSIAN TRADING SYSTEM"; STOCK EXCHANGE, RUSSIAN FED.:  
3,939,904, PUB. 1-18-2011. MULTIPLE CLASS, INT. CLS. 9, 16, 35 AND 36.
- OPEN MENU, ELGIN, SC:  
3,940,498, PUB. 1-18-2011. INT. CL. 42.
- OPEN TEXT, INC., LINCOLNSHIRE, IL:  
2,367,814, CANC. INT. CL. 9.
- OPENSTREET USA INCORPORATED, NIAGARA FALLS, NY AND OPENSTREET CANADA INCORPORATED, WELLAND, ONTARIO, CANADA:  
3,939,714, PUB. 1-18-2011. INT. CL. 36.
- OPHTHALMIC IMAGING SYSTEMS, SACRAMENTO, CA:  
3,939,697, PUB. 1-18-2011. INT. CL. 10.
- OPI PRODUCTS, INC., NORTH HOLLYWOOD, CA:  
2,420,672, REN. 2-28-11. INT. CL. 3.
- OPIA PROPERTIES, LLC, PROSPECT, KY:  
2,864,662, CANC. INT. CL. 36.
- OPINIONSEA, LLC, HEBER CITY, UT:  
3,940,369, PUB. 1-18-2011. INT. CL. 38.
- OPTEX CO., LTD., OTSU-SHI, SHIGA, JAPAN:  
3,941,623, INT. CL. 9.
- OPTIMAL HEARING SYSTEMS, INC, SAVANNAH, GA:  
3,940,669, PUB. 1-18-2011. INT. CL. 44.
- OPUS EVENTS INTERNATIONAL, INC., TIBURON, CA:  
3,941,066, INT. CL. 36.
- OQUIRRH INSTITUTE, SALT LAKE CITY, UT:  
2,864,395, CANC. MULTIPLE CLASS, INT. CLS. 41 AND 42.

ORCHARD YARN AND THREAD COMPANY, INC., NEW YORK, NY, DBA LION BRAND YARN COMPANY: 3,939,510, PUB. 1-18-2011. INT. CL. 23.

ORGANIC MATERIALS REVIEW INSTITUTE, EUGENE, OR: 3,939,382, PUB. 1-18-2011. U.S. CL. A.

ORGANIC PRODUCTS TRADING COMPANY, VANCOUVER, WA: 2,865,793, CANC. INT. CL. 30.

ORIBE HAIR CARE, LLC, NEW YORK, NY: 3,939,632, PUB. 1-18-2011. MULTIPLE CLASS, INT. CLS. 3 AND 35.

ORIENTAL TRADING COMPANY, INC., OMAHA, NE: 2,100,038, CANC. MULTIPLE CLASS, INT. CLS. 14 AND 28.

ORIGENIS GMBH, MARTINSRIED, FED REP GERMANY: 2,873,142, CANC. MULTIPLE CLASS, INT. CLS. 7 AND 9.

ORIGINAL CASCADE CLOTHING CO., INC., LOS ANGELES, CA: 2,368,237, CANC. INT. CL. 25.

ORIGINAL CAST LIGHTING, INC., THE, ST. LOUIS, MO: 2,522,212, REN. 2-25-11. INT. CL. 35.

ORIGINAL MOXIE, LLC, YPSILANTI, MI: 3,940,579, PUB. 1-18-2011. INT. CL. 3.

ORKAT, LLC, WESTWOOD, MA, EMPIRE OF MAINE, TOPSFIELD, MA: 1,646,357, REN. 3-2-11. INT. CL. 42.

ORKAT, LLC, WESTWOOD, MA: 2,445,623, REN. 2-26-11. INT. CL. 35.

ORKIN EXPANSION, INC., WILMINGTON, DE: 3,941,416, INT. CL. 37.  
3,941,417, INT. CL. 37.

ORLANDO REGIONAL REALTOR ASSOCIATION, INC., ORLANDO, FL: 2,702,246, CANC. INT. CL. 35.

ORLANDO/ORANGE COUNTY CONVENTION & VISITORS BUREAU, INC., THE, ORLANDO, FL: 2,465,153, REN. 2-26-11. MULTIPLE CLASS, INT. CLS. 16 AND 35.

ORMAN CONSULTING INC., BLACK EARTH, WI: 2,539,036, REN. 2-26-11. INT. CL. 35.

ORNER, GUY, CULVER CITY, CA: 2,865,346, CANC. INT. CL. 28.

ORPHAN LIFELINE, CASTLE ROCK, CO: 3,940,242, PUB. 1-18-2011. INT. CL. 36.

ORTHOBANC, LLC, CHATTANOOGA, TN: 3,939,528, PUB. 1-18-2011. INT. CL. 36.

ORVIS COMPANY, INC., THE, SUNDERLAND, VT: 2,454,958, REN. 2-28-11. MULTIPLE CLASS, INT. CLS. 35, 39, 40, 41 AND 42.  
2,456,616, REN. 3-1-11. INT. CL. 28.

OSCAR MESANZA MATIA, E-48009 BILBAO (VIZCAYA), SPAIN: 3,940,017, PUB. 1-18-2011. INT. CL. 5.

OSMENT, DAVID L., NAPLES, FL: 3,447,431, AM. INT. CL. 28.

OSSACUR AG, OBERSTENFELD, FED REP GERMANY: 2,864,859, CANC. INT. CL. 5.

OSTROWSKI, LAURA LEE, NOVATO, CA: 2,864,503, CANC. INT. CL. 9.

OTC, INC., AIKEN, SC: 3,940,612, PUB. 1-18-2011. INT. CL. 5.

OTICON, INC., SOMERSET, NJ: 3,941,570, MULTIPLE CLASS, INT. CLS. 10 AND 44.

OUELLET, DAVID, WOODBRIDGE, ONTARIO, CANADA: 2,516,019, REN. 3-1-11. INT. CL. 16.

OUSLEY N EARLY JR., SAINT PAUL, MN: 3,942,109, INT. CL. 16.

OUT OF THE BLUE ENTERPRISES LLC, NEW YORK, NY: 3,941,016, INT. CL. 25.  
3,941,249, INT. CL. 21.

OUT OF THE BOX PUBLISHING, INC., WINDSOR, WI: 3,941,386, INT. CL. 28.

OUTREACH LIMITED, FALKIRK, SCOTLAND, UNITED KINGDOM: 2,368,827, CANC. INT. CL. 7.

OUTWATER PLASTICS INDUSTRIES, INC., BOGOTA, NJ: 2,368,817, CANC. INT. CL. 6.

OVER THE SUN, LLC, LOVELAND, CO: 3,941,524, MULTIPLE CLASS, INT. CLS. 9 AND 42.

OWDM, LLC, NORTHBROOK, IL: 2,422,900, REN. 3-3-11. INT. CL. 35.

OWEN CRAIG POLLARD, SAN MARCOS, CA: 3,941,844, INT. CL. 28.

OXFORD FINANCIAL SERVICES, ALEXANDRIA, VA: 3,942,287, INT. CL. 36.

OXFORD LIFE INSURANCE COMPANY, PHOENIX, AZ: 2,368,636, CANC. INT. CL. 36.

OXON THERAPEUTICS LIMITED, OXFORD, UNITED KINGDOM: 2,863,943, CANC. MULTIPLE CLASS, INT. CLS. 5, 9, 16 AND 42.

P T C, SEINE SAINT-DENIS, FRANCE: 2,367,513, CANC. INT. CL. 7.

P.D. OF MIAMI, INC, DELAND, FL: 2,506,698, REN. 2-26-11. INT. CL. 12.

P.D. OF MIAMI, INC., DELAND, FL: 2,494,483, REN. 3-2-11. INT. CL. 12.  
2,506,699, REN. 2-26-11. INT. CL. 12.  
2,506,700, REN. 2-26-11. INT. CL. 12.

P&O NEDLLOYD LOGISTICS LLC, EAST RUTHERFORD, NJ: 2,865,007, CANC. MULTIPLE CLASS, INT. CLS. 38 AND 39.

PABISAN, S.A. DE C.V., PUEBLA, MEXICO: 3,940,216, PUB. 1-18-2011. MULTIPLE CLASS, INT. CLS. 5 AND 30.

PABST BREWING COMPANY, WOODRIDGE, IL: 715,535, REN. 3-2-11. U.S. CL. 48 (INT. CL. 32).

PAC PAPER, INC., VANCOUVER, WA: 2,864,822, CANC. INT. CL. 16.

PACIFIC COAST FEATHER COMPANY, SEATTLE, WA: 3,941,758, MULTIPLE CLASS, INT. CLS. 20 AND 24.

PACIFIC LIGHTNET, HONOLULU, HI: 2,864,168, CANC. INT. CL. 38.

PACIFIC LIGHTNET, INC., HONOLULU, HI: 2,864,169, CANC. INT. CL. 38.

PACIFIC SPECIALTY OILS, INC., MOUNTAIN VIEW, CA: 3,941,497, INT. CL. 3.

PACIFIC SYSTEMS DESIGN TECHNOLOGIES, PORT ANGELES, WA: 3,940,667, PUB. 1-18-2011. INT. CL. 41.

PACIFICPHARMA CORPORATION, SEOUL, REPUBLIC OF KOREA: 3,939,423, PUB. 1-18-2011. INT. CL. 3.

PACKET SOLUTIONS, INC., CLEARWATER, FL: 3,940,393, PUB. 1-18-2011. INT. CL. 3.

PACON CORPORATION, APPLETON, WI: 916,924, REN. 2-25-11. U.S. CL. 37 (INT. CL. 16).

PAIGE LIMITED CORP., PANAMA, PANAMA: 3,941,245, INT. CL. 32.

PAIGE, RENE, BOCA RATON, FL: 2,865,366, CANC. INT. CL. 42.

PAKSENSE, INC., BOISE, ID: 3,432,840, COR. INT. CL. 9.

PALFINGER AG, 5101 BERGHEIM, AUSTRIA: 3,941,110, INT. CL. 7.

PALLADIO HOMES, INC., MT. PLEASANT, SC: 2,864,354, CANC. INT. CL. 37.  
2,864,365, CANC. INT. CL. 37.

PALLETIZED TRUCKING INC., HOUSTON, TX: 3,939,438, PUB. 1-18-2011. INT. CL. 39.

PALM, SHERRIE, MUKWONAGO, WI, DBA ASSOCIATION FOR PELVIC ORGAN PROLAPSE SUPPORT, INC.: 3,942,300, INT. CL. 45.

PALMER & CAY, LLC, ATLANTA, GA: 3,941,849, INT. CL. 36.

PALMER SNYDER FURNITURE COMPANY, MILWAUKEE, WI: 3,942,398, INT. CL. 20.

PALO ALTO SOFTWARE, INC., EUGENE, OR: 2,529,972, REN. 3-2-11. INT. CL. 35.

PALOMAR MEDICAL TECHNOLOGIES, INC., BURLINGTON, MA: 3,942,431, INT. CL. 10.

- PAN AMERICAN HEALTH AND EDUCATION FOUNDATION, WASHINGTON, DC, AKA PAHEF:  
3,939,811, PUB. 1-18-2011. MULTIPLE CLASS, INT. CLS. 41, 42 AND 44.
- PANAMEDIA GROUP, LLC, ST. LOUIS, MO:  
3,941,731, INT. CL. 38.  
3,941,732, INT. CL. 9.
- PANASONIC CORPORATION OF NORTH AMERICA, SECAUCUS, NJ:  
3,941,422, INT. CL. 9.
- PANCOSKI, STEVE, CAMP HILL, PA:  
2,865,096, CANC. INT. CL. 32.
- PANDA RHAND LLC, SCARSDALE, NY:  
3,939,500, PUB. 1-18-2011. INT. CL. 25.
- PANMEDIA INFORMATION CORPORATION, SAUSALITO, CA:  
2,319,616, CANC. INT. CL. 35.
- PANOPTIS IP, LLC, DALLAS, TX:  
3,940,909, PUB. 1-18-2011. MULTIPLE CLASS, INT. CLS. 35 AND 36.
- PANPROD S.A., KALAMATA, MESSINIA, GREECE:  
3,941,180, INT. CL. 29.
- PANTEL VENTURES LIMITED, PROVIDENCIALES, TURKS/CAICOS IS.:  
3,941,175, INT. CL. 38.  
3,941,176, INT. CL. 38.  
3,941,177, INT. CL. 38.
- PAPILLON S.P.A., VANCIMUGLIO DI GRUMOLO DELLE ABBADDESSE, ITALY:  
2,430,856, REN. 2-26-11. MULTIPLE CLASS, INT. CLS. 18 AND 25.
- PAPPAS, MICHAEL ALEXANDER, TEMPE, AZ:  
3,941,254, INT. CL. 33.
- PAR TECHNOLOGY CORPORATION, NEW HARTFORD, NY:  
3,941,798, MULTIPLE CLASS, INT. CLS. 9, 42 AND 43.  
3,941,799, MULTIPLE CLASS, INT. CLS. 9, 42 AND 43.  
3,941,800, INT. CL. 42.  
3,941,801, INT. CL. 43.
- PARADIGM SCIENCES LTD., GEORGE TOWN, CAYMAN ISLANDS:  
3,939,446, PUB. 1-18-2011. MULTIPLE CLASS, INT. CLS. 9, 41 AND 42.  
3,939,447, PUB. 1-18-2011. MULTIPLE CLASS, INT. CLS. 9, 41 AND 42.
- PARFUMS CHRISTIAN DIOR DIRECTION JURIDIQUE, FRANCE:  
3,940,050, PUB. 1-18-2011. INT. CL. 3.
- PARIS ACCESSORIES, INC., NEW YORK, NY:  
1,636,200, REN. 3-1-11. INT. CL. 25.
- PARK B. SMITH, INC., NEW YORK, NY, DBA PARK B. SMITH LTD.:  
1,611,290, REN. 2-28-11. MULTIPLE CLASS, INT. CLS. 24 AND 27.
- PARK INDUSTRIES, INC., ST. CLOUD, MN:  
2,864,413, CANC. MULTIPLE CLASS, INT. CLS. 7 AND 9.
- PARK NICOLLET HEALTH SERVICES, ST. LOUIS PARK, MN:  
2,527,368, REN. 3-2-11. INT. CL. 42.
- PARK, JUNG AE, LOS ANGELES, CA:  
2,865,790, CANC. INT. CL. 25.
- PARKE BANCORP, INC., SEWELL, NJ:  
3,942,234, INT. CL. 36.
- PARKMOBILE USA, INC., ATLANTA, GA:  
3,941,988, MULTIPLE CLASS, INT. CLS. 36 AND 42.  
3,941,989, MULTIPLE CLASS, INT. CLS. 36 AND 42.
- PARRIS MANUFACTURING CO., INC., SAVANNAH, TN:  
2,865,820, CANC. INT. CL. 25.
- PARTNERS IN LEADERSHIP IP, LLC, TEMECULA, CA:  
3,939,850, PUB. 1-18-2011. MULTIPLE CLASS, INT. CLS. 35 AND 41.
- PASS & SEYMOUR, INC., SYRACUSE, NY:  
2,368,376, CANC. INT. CL. 9.
- PASTFUTURE, INC., NEW YORK, NY:  
3,941,280, MULTIPLE CLASS, INT. CLS. 35 AND 41.
- PASTURELAND, GOODHUE, MN:  
3,942,130, INT. CL. 29.
- PATENTS+TMS, P.C., CHICAGO, IL:  
2,937,218, CANC. INT. CL. 42.
- PATERNITY PAINS LLC, NEW YORK, NY:  
3,941,925, INT. CL. 35.
- PATIENT SAFETY ORGANIZATION ONE, INC., BATTLE CREEK, MI, DBA PSO ONE, INC.:  
3,941,639, MULTIPLE CLASS, INT. CLS. 35 AND 41.
- PATRICK CHEMOUL, LOS ANGELES, CA:  
3,939,610, PUB. 1-18-2011. INT. CL. 25.
- PATRIOT ENVIRONMENTAL SERVICES, LONG BEACH, CA:  
3,940,511, PUB. 1-18-2011. INT. CL. 37.
- PATRON SPIRITS INTERNATIONAL AG, SCHAFFHAUSEN, SWITZERLAND:  
3,942,047, INT. CL. 33.
- PATTERSON, LYNDON, HONOLULU, HI:  
3,941,968, INT. CL. 15.
- PAUL DUVAL PTY LTD, TULLAMARINE, VICTORIA 3043, AUSTRALIA:  
2,864,616, CANC. INT. CL. 3.
- PAUTIN, REYNALDO, REDWOOD CITY, CA AND VAILLEAU, PHILIPPE, REDWOOD CITY, CA AND VAILLEAU, MARIA CLARA PAUTIN GANTAN, REDWOOD CITY, CA:  
3,940,613, PUB. 1-18-2011. INT. CL. 25.
- PAW IMPRESSIONS, MENLO PARK, CA:  
2,368,398, CANC. INT. CL. 16.  
2,368,399, CANC. INT. CL. 16.
- PAWSENCLAWS & CO., LLC, NEW VERNON, NJ:  
2,864,086, CANC. INT. CL. 28.
- PAX INTELLECTUAL PROPERTY HOLDINGS, INC., NEW YORK, NY:  
3,939,388, PUB. 1-18-2011. INT. CL. 43.
- PAYLESS SHOESOURCE WORLDWIDE, INC., TOPEKA, KS:  
3,941,159, MULTIPLE CLASS, INT. CLS. 35 AND 45.  
3,942,330, INT. CL. 25.
- PBC INTERNATIONAL, INC., OXNARD, CA:  
2,767,745, CANC. INT. CL. 28.
- PBM PRODUCTS, LLC, GORDONSVILLE, VA:  
3,941,593, INT. CL. 30.  
3,941,631, INT. CL. 30.  
3,941,750, INT. CL. 5.
- PC SYNERGY, INC., SAN MARCOS, CA:  
2,542,742, REN. 3-3-11. INT. CL. 9.
- PC TREASURES, INC., OXFORD, MI:  
3,942,191, INT. CL. 9.
- PEAK PORTFOLIO, INC., GIG HARBOR, WA:  
3,940,493, PUB. 1-18-2011. INT. CL. 35.
- PEARL MEYER & PARTNERS, LLC, NEW YORK, NY:  
2,864,579, CANC. INT. CL. 35.
- PEARSON, ADRIAN, SANTA CRUZ, CA, DBA PEARSON RESEARCH:  
2,510,891, REN. 2-25-11. INT. CL. 35.
- PEDERSEN, KAARE, EFFINGHAM, IL:  
3,941,696, INT. CL. 41.
- PEDERSON'S NATURAL FARMS, INC., HAMILTON, TX:  
3,939,728, PUB. 1-18-2011. INT. CL. 29.
- PEEPOOPLE AB, 116 41 STOCKHOLM, SWEDEN:  
3,843,557, COR. MULTIPLE CLASS, INT. CLS. 5, 16, 35, 41 AND 44.
- PEIRCE-PHELPS, INC., PHILADELPHIA, PA:  
2,466,259, REN. 2-25-11. INT. CL. 41.  
2,480,546, REN. 2-25-11. INT. CL. 37.
- PENFORD PRODUCTS CO., CEDAR RAPIDS, IA:  
2,368,659, CANC. INT. CL. 1.
- PENNSYLVANIA VETERINARY FOUNDATION, HERSHEY, PA:  
3,940,191, PUB. 1-18-2011. INT. CL. 41.
- PENNWELL CORPORATION, TULSA, OK:  
2,864,358, CANC. INT. CL. 35.  
2,864,412, CANC. INT. CL. 16.  
2,864,460, CANC. INT. CL. 35.  
2,864,492, CANC. INT. CL. 35.
- PENNZOIL-QUAKER STATE COMPANY, HOUSTON, TX:  
2,864,898, CANC. INT. CL. 4.
- PENTON BUSINESS MEDIA, INC., NEW YORK, NY:  
3,940,096, PUB. 1-18-2011. INT. CL. 41.

PENZEYS, LTD., BROOKFIELD, WI:  
3,942,187, INT. CL. 30.

PEOPLE INK CORPORATION, ALBUQUERQUE, NM:  
3,940,839, PUB. 1-18-2011. INT. CL. 35.

PEOPLE LINK, INC., HOUSTON, TX:  
2,499,467, REN. 3-3-11. MULTIPLE CLASS, INT. CLS. 41 AND 42.

PEPPER JAY PRODUCTIONS, LLC., LOS ANGELES, CA:  
3,941,895, INT. CL. 41.

PERDUE HOLDINGS, INC., WILMINGTON, DE:  
3,942,055, INT. CL. 29.

PERFECT PRODUCTS, TULSA, OK:  
3,940,517, PUB. 1-18-2011. INT. CL. 6.

PERFECTION UNIFORMS, LLC, BRENTWOOD, TN:  
3,939,645, PUB. 1-18-2011. INT. CL. 25.

PERFETTI SALES & MARKETING, INC., COUNTRYSIDE, IL:  
3,941,935, INT. CL. 30.

PERFORMANCE FABRICS, INC., GRAND RAPIDS, MI, DBA HEXARMOR:  
3,941,981, INT. CL. 9.

PERKINS & MARIE CALLENDER'S INC., MEMPHIS, TN, PERKINS RESTAURANTS OPERATING COMPANY, L.P., MEMPHIS, TN:  
1,663,533, REN. 2-26-11. INT. CL. 29.

PERKINS & MARIE CALLENDER'S INC., MEMPHIS, TN:  
2,490,366, REN. 2-26-11. MULTIPLE CLASS, INT. CLS. 30 AND 42.  
2,492,247, REN. 2-26-11. MULTIPLE CLASS, INT. CLS. 30 AND 42.

PERKY'S FOODSERVICE CONCEPTS, INC., OLDSMAR, FL:  
3,939,812, PUB. 1-18-2011. INT. CL. 35.

PERPETUAL MOTION FITNESS CORPORATION, CHICAGO, IL:  
3,941,567, INT. CL. 41.

PERTHOU PETER, MINNEAPOLIS, MN:  
2,373,832, REN. 3-1-11. INT. CL. 6.

PESCE VITA, LYNN, YONKERS, NY:  
3,942,185, INT. CL. 41.

PEST LABORATORIES, LLC, HEWITT, NJ, DBA PEST LABORATORIES:  
3,940,257, PUB. 1-18-2011. INT. CL. 37.

PETER GEORGE GUNN, ESCALDES ENGORDANY, ANDORRA:  
3,939,782, PUB. 1-18-2011. MULTIPLE CLASS, INT. CLS. 6, 37 AND 42.

PETER HUBER KÄLTEMASCHINENBAU GMBH, FED REP GERMANY:  
3,939,988, PUB. 1-18-2011. MULTIPLE CLASS, INT. CLS. 7, 9 AND 11.

PETER PAN RESTAURANT MANAGEMENT AND CONSULTANTS, INC., CHICAGO, IL, PETER PAN RESTAURANTS, INC., CHICAGO, IL:  
1,636,243, REN. 3-2-11. INT. CL. 29.

PETERIK, JIM, BURR RIDGE, IL:  
2,428,511, REN. 2-26-11. INT. CL. 9.  
2,434,837, REN. 2-26-11. INT. CL. 9.

PETERSON, ROBERT NEAL, HARPERS FERRY, WV:  
3,941,736, INT. CL. 31.  
3,941,737, INT. CL. 31.  
3,941,738, INT. CL. 31.

PETR LITOMISKY AND ALES LIOMISKY, HOLLYWOOD, CA, DBA ECOGATE:  
2,367,709, CANC. INT. CL. 7.

PETRA PET, INC., NORTH BERGEN, NJ, DBA PETRAPORT:  
3,941,463, INT. CL. 31.  
3,941,464, INT. CL. 31.

PEX CONNECTION INC., OKLAHOMA CITY, OK:  
2,713,605, CANC. INT. CL. 6.

PFANNENBERG GMBH, D-21035 HAMBURG, FED REP GERMANY:  
3,939,351, PUB. 1-18-2011. MULTIPLE CLASS, INT. CLS. 11 AND 16.

PFIZER INC., NEW YORK, NY:  
2,865,428, CANC. INT. CL. 5.  
2,865,429, CANC. INT. CL. 5.

PFOODMAN HOLDINGS, L.L.C. BALLWIN, MO:  
3,939,376, PUB. 1-18-2011. INT. CL. 43.

PGI, INC., ALEXANDRIA, VA:  
2,864,890, CANC. MULTIPLE CLASS, INT. CLS. 35, 39, 41 AND 42.

PGT INDUSTRIES, INC., NOKOMIS, FL:  
2,368,299, CANC. MULTIPLE CLASS, INT. CLS. 6 AND 19.

PH INTERNATIONAL, LLC, MADISON, VA:  
2,442,235, REN. 2-26-11. INT. CL. 35.

PHADIA AB, SE-751 37 UPPSALA, SWEDEN:  
3,939,893, PUB. 1-18-2011. MULTIPLE CLASS, INT. CLS. 5 AND 10.

PHARMACIST'S ULTIMATE HEALTH CORP., ST. PAUL, MN:  
2,863,892, CANC. INT. CL. 5.

PHASE 3 CONSULTING, LLC., BROOKEVILLE, MD:  
3,940,214, PUB. 1-18-2011. MULTIPLE CLASS, INT. CLS. 35 AND 36.

PHASERX, INC., SEATTLE, WA:  
3,941,026, INT. CL. 42.

PHIL WALDREP EVANGELISTIC ASSOCIATION, TRINITY, AL:  
2,865,253, CANC. INT. CL. 41.

PHILADELPHIA RIVERBOAT LLC, NORFOLK, VA:  
3,942,143, MULTIPLE CLASS, INT. CLS. 39, 41 AND 43.

PHILIPS SOLID-STATE LIGHTING SOLUTIONS, INC., BURLINGTON, MA:  
2,368,112, CANC. MULTIPLE CLASS, INT. CLS. 9 AND 11.

PHILLIP S. MARTIN, MARION, VA, DBA BLUE RIDGE KNIVES:  
3,940,326, PUB. 1-18-2011. INT. CL. 8.  
3,940,327, PUB. 1-18-2011. INT. CL. 8.

PHILLIPS, CURTIS, CHATTANOOGA, TN:  
3,941,863, INT. CL. 11.

PHILOSOPHY, INC., PHOENIX, AZ:  
3,941,142, INT. CL. 3.

PHN, LLC, DANVILLE, CA:  
3,941,719, INT. CL. 41.

PHO 75, INC., HERNDON, VA:  
2,368,461, CANC. INT. CL. 42.

PHOENIX ELECTRIC CO., LTD., HYOGO 679-2122, JAPAN, DBA P.E.C. JAPAN:  
1,637,531, REN. 2-28-11. INT. CL. 11.

PHOENIX SCHOOL, INC., THE, SALEM, MA:  
2,676,433, CANC. INT. CL. 41.

PHOENIX WIRELESS, INC., HATFIELD, PA:  
3,941,255, INT. CL. 9.

PHONIC EAR A/S, SMORUM, DENMARK:  
3,940,122, PUB. 1-18-2011. INT. CL. 9.

PHOTOMISSION, INC., WEST CHESTER, PA:  
3,941,740, MULTIPLE CLASS, INT. CLS. 35 AND 41.

PHYSICIANS MUTUAL INSURANCE COMPANY, OMAHA, NE:  
3,940,531, PUB. 1-18-2011. MULTIPLE CLASS, INT. CLS. 36 AND 41.

PI-DESIGN AG, CH-6234 TRIENGEN, SWITZERLAND:  
2,460,857, REN. 2-25-11. INT. CL. 21.  
2,863,987, CANC. MULTIPLE CLASS, INT. CLS. 8, 21 AND 24.

PIAGGIO & C. S.P.A., ITALY:  
3,699,130, COR. INT. CL. 12.

PICKETT, ADRIENE, LOS ANGELES, CA:  
3,941,939, INT. CL. 3.

PICKY RICKY, INC., SAN MATEO, CA:  
3,940,676, PUB. 1-18-2011. INT. CL. 35.

PIEPERS ENTERPRISES, INC., BLOOMFIELD HILLS, MI:  
3,940,768, PUB. 1-18-2011. INT. CL. 43.

PIERDOMENICO, VINCENT JAMES, BROOKHAVEN, PA:  
2,368,613, CANC. MULTIPLE CLASS, INT. CLS. 9 AND 41.

PIERRE FABRE S.A., PARIS, FRANCE:  
3,939,794, PUB. 1-18-2011. MULTIPLE CLASS, INT. CLS. 3 AND 5.

PIERRE FABRE SANTE, 92100 BOULOGNE, FRANCE:  
2,368,315, CANC. MULTIPLE CLASS, INT. CLS. 3 AND 5.

- PILKINGTON PLC, MERSEYSIDE WA10 3TT, ENGLAND:  
2,561,113, CANC. INT. CL. 9.
- PILLSBURY COMPANY, THE, MINNEAPOLIS, MN:  
2,436,993, REN. 2-26-11. INT. CL. 41.
- PIMENTEL, MICHAEL A, FREMONT, CA:  
3,940,103, PUB. 1-18-2011. INT. CL. 35.
- PINHO, NATHAN, ROSELLE, NJ:  
3,941,161, INT. CL. 16.
- PINK AVENUE LIMITED, LONDON N4 1TD, UNITED KINGDOM:  
2,865,690, CANC. INT. CL. 25.
- PINK SWIRL FROZEN YOGURT LLC, FREMONT, CA:  
3,939,464, PUB. 9-22-2009. INT. CL. 30.
- PINNACLE FOODS GROUP, INC., MOUNTAIN LAKES, NJ:  
2,432,756, REN. 2-26-11. INT. CL. 29.
- PINNACLE SYSTEMS GROUP INC., DOWNINGTOWN, PA:  
2,863,915, CANC. MULTIPLE CLASS, INT. CLS. 35 AND 42.
- PIONEER HI-BRED INTERNATIONAL, INC., JOHNSTON, IA:  
3,941,111, MULTIPLE CLASS, INT. CLS. 16, 31 AND 44.
- PIPEALIGN, LLC, SCOTTSDALE, AZ:  
2,864,187, CANC. INT. CL. 35.
- PITNEY BOWES INC., STAMFORD, CT:  
2,367,419, CANC. MULTIPLE CLASS, INT. CLS. 35 AND 39.
- PITTORE, NICOLE, DERRY, NH, DBA NECKSPAWINGS:  
3,940,828, PUB. 1-18-2011. INT. CL. 20.
- PIXAMI, INC., PLEASANTON, CA:  
2,431,526, REN. 2-26-11. INT. CL. 9.
- PIZZA PATRON, INC., DALLAS, TX:  
3,940,578, PUB. 1-18-2011. INT. CL. 43.
- PLACE FOR TILE, INC., THE, MIAMI, FL:  
2,367,979, CANC. INT. CL. 19.
- PLANET KNOX LIMITED, CUMBRIA, UNITED KINGDOM:  
2,368,412, CANC. INT. CL. 9.
- PLANT DEVAS, INC., ENCINITAS, CA:  
3,939,709, PUB. 1-18-2011. INT. CL. 3.
- PLASTIBEC INC., BOISBRIAND, QUEBEC, CANADA:  
3,939,655, PUB. 1-18-2011. MULTIPLE CLASS, INT. CLS. 19 AND 20.
- PLASTICOS TECNICOS MEXICANOS, S.A. DE C.V., 64410 MONTERREY, N.L., MEXICO:  
2,864,035, CANC. INT. CL. 20.
- PLASTIVAL INC, ELGIN, IL:  
2,864,418, CANC. INT. CL. 19.
- PLASTO, FRANCE:  
3,940,023, PUB. 1-18-2011. MULTIPLE CLASS, INT. CLS. 1, 5 AND 17.
- PLAYBOY ENTERPRISES INTERNATIONAL, INC., CHICAGO, IL:  
3,941,190, INT. CL. 25.
- PLAYBRAINS, INC., OTTAWA, ONTARIO, CANADA:  
3,939,536, PUB. 1-18-2011. MULTIPLE CLASS, INT. CLS. 9 AND 41.
- PLAYCORE IP SUB, INC., CHATTANOOGA, TN:  
2,499,003, REN. 2-26-11. INT. CL. 28.
- PLAYKIDS U.S.A., INC., BROOKLYN, NY:  
2,368,242, CANC. INT. CL. 28.
- PLAYMATES IP LIMITED, TSIMSHATSUI, KOWLOON, HONG KONG, LESNEY PRODUCTS CORPORATION, MOONACHIE, NJ:  
1,175,332, REN. 3-2-11. INT. CL. 28.
- PLAYTEX PRODUCTS, INC., WESTPORT, CT:  
2,865,490, CANC. INT. CL. 41.
- PLEIN, EDWARD, KASSON, MN:  
3,939,476, PUB. 1-18-2011. INT. CL. 35.
- PLENUS, SOCIEDAD ANONIMA DE CAPITAL VARIABLE, SAN PEDRO GARZA GARCIA, MEXICO:  
3,942,061, INT. CL. 35.
- PLEWS, INC., DIXON, IL:  
2,482,018, REN. 2-25-11. MULTIPLE CLASS, INT. CLS. 7 AND 9.
- PLUMB RIGHT SERVICES, GARLAND, TX:  
3,940,273, PUB. 1-18-2011. INT. CL. 37.
- PLUMLEE, GREG, FOOTHILL RANCH, CA AND PLUMLEE, RENEE, FOOTHILL RANCH, CA:  
3,941,987, INT. CL. 6.
- PLYMOUTH TRADING COMPANY, LLC, PLYMOUTH, MN:  
3,942,247, INT. CL. 16.
- PLYMOUTH TUBE COMPANY, WARRENVILLE, IL:  
1,663,934, REN. 3-3-11. INT. CL. 6.
- PM FACTORS, INC., LOS ANGELES, CA:  
2,455,383, CANC. INT. CL. 36.
- PMC GAGE, INC., WILLOUGHBY, OH:  
3,942,081, INT. CL. 9.
- POINT CLASSICS, LLC, NASHVILLE, TN:  
2,864,132, CANC. INT. CL. 9.
- POLA CHEMICAL INDUSTRIES INC., SHIZUOKA-KEN, JAPAN:  
3,941,915, INT. CL. 3.  
3,941,917, INT. CL. 3.
- POLAR ELECTRO OY, 90440 KEMPELE, FINLAND:  
2,444,670, REN. 3-2-11. MULTIPLE CLASS, INT. CLS. 10 AND 14.
- POLAR ELECTRO OY, 90440 KEMPLE, FINLAND:  
2,444,671, REN. 3-2-11. MULTIPLE CLASS, INT. CLS. 10 AND 14.
- POLLY PIG BY KNAPP, INC., HOUSTON, TX:  
2,435,893, REN. 3-2-11. INT. CL. 7.
- POLY-TECH INDUSTRIES, INC., ROGERS, MN:  
2,368,225, CANC. INT. CL. 7.
- POLYFAB MEDICAL, LLC, WOODBRIDGE, VA:  
3,941,838, INT. CL. 20.
- POLYGIENE AB, MALMO, SWEDEN:  
3,941,728, INT. CL. 5.
- POLYMATECH CO. LTD., CHUO-KU, TOKYO, JAPAN:  
2,864,259, CANC. INT. CL. 9.
- POLYTEX SPORTBELÄGE PODUKTIONS-GMBH, FED REP GERMANY:  
3,939,897, PUB. 1-18-2011. MULTIPLE CLASS, INT. CLS. 27 AND 37.
- PONTE NYC LLC, NEW YORK CITY, NY, DBA ECOSTASY:  
3,939,667, PUB. 1-18-2011. INT. CL. 35.
- POOCH ENTERPRISES, LLC, MIAMI, FL:  
3,942,216, INT. CL. 3.
- POOLE, WILLIAM E., WILMINGTON, NC:  
2,865,702, CANC. INT. CL. 27.
- POOR, BROKE, & HANDSOM INC., SAN PEDRO, CA:  
3,939,711, PUB. 1-18-2011. INT. CL. 25.
- PORTER, ROBERT, A, OVIEDO, FL, DBA MOXIE MEDIA:  
3,942,396, INT. CL. 41.
- PORTLAND DESIGN WORKS, LLC, PORTLAND, OR:  
3,939,352, PUB. 1-18-2011. INT. CL. 12.
- PORTLAND STATE UNIVERSITY, PORTLAND, OR:  
2,537,955, REN. 2-26-11. INT. CL. 41.
- PORTMAN-LAUX, CATHERINE, GARRISON, NY:  
2,439,552, REN. 3-2-11. INT. CL. 16.  
2,448,445, REN. 3-2-11. INT. CL. 16.
- PORTRAIT DISPLAYS, INC., PLEASANTON, CA:  
2,381,737, CANC. INT. CL. 9.
- POSITIVE OUTCOMES, INC., WILDWOOD, MO:  
3,941,779, INT. CL. 21.
- POST-TENSIONING INSTITUTE, PHOENIX, AZ:  
2,864,270, CANC. U.S. CL. 200.
- POSTELL PUBLISHING LLC, BOWIE, MD:  
3,941,528, MULTIPLE CLASS, INT. CLS. 35 AND 41.
- POWER BOX AG, ZUG, SWITZERLAND:  
3,939,408, PUB. 1-18-2011. INT. CL. 7.
- POWERS, JOHN GORDON, CAMBRIDGE, ON, CANADA:  
2,864,788, CANC. INT. CL. 10.
- PPC MARKETING, LTD., GREELEY, CO:  
3,942,272, INT. CL. 29.
- PPG INDUSTRIES OHIO, INC., CLEVELAND, OH, PPG INDUSTRIES, INC., PITTSBURGH, PA:  
1,638,782, REN. 3-3-11. INT. CL. 1.
- PRAETZEL, PAUL, MATTHEW, TELFORD, PA:  
3,939,368, PUB. 1-18-2011. INT. CL. 42.
- PRASCO, LLC, MASON, OH:  
3,940,347, PUB. 1-18-2011. INT. CL. 35.
- PRATT & WHITNEY CANADA CORP., LONGUEUIL, QUEBEC, CANADA:  
1,646,279, REN. 2-26-11. INT. CL. 37.
- PRECISE, INC., PITTSBURGH, PA:  
3,940,559, PUB. 1-18-2011. INT. CL. 9.



PRECISIONEERING LIMITED, SCARBOROUGH, ONTARIO, CANADA:  
3,939,507, PUB. 1-18-2011. MULTIPLE CLASS, INT. CLS. 7 AND 40.

PRECURSOR GROUP, THE, WASHINGTON, DC:  
2,864,456, CANC. INT. CL. 16.

PREDICTIVE BIOSCIENCES, INC., LEXINGTON, MA:  
3,941,426, INT. CL. 5.

PREFCO CORP., HOUSTON, TX:  
2,459,977, REN. 2-26-11. INT. CL. 29.

PREFERRED HOSPITALITY, INC., RIVERSIDE, CA, FORMERLY MARKET BROILER MANAGEMENT, INC.:  
3,940,803, PUB. 1-18-2011. INT. CL. 43.

PREFERRED TEA, LLC, ARLINGTON, TX:  
3,940,475, PUB. 1-18-2011. INT. CL. 30.

PREFERRED UTILITIES MFG. CORP., DANBURY, CT:  
2,713,642, CANC. INT. CL. 9.

PREKINDLE, LLC, DALLAS, TX:  
3,940,254, PUB. 1-18-2011. MULTIPLE CLASS, INT. CLS. 35 AND 41.

PRELIGHT DAY PRODUCTIONS, INC., LONG ISLAND CITY, NY:  
3,940,545, PUB. 1-18-2011. INT. CL. 42.

PRESSMAN TOY CORPORATION, NEW YORK, NY:  
1,167,500, REN. 2-26-11. INT. CL. 28.

PRESTAT LIMITED, LONDON, UNITED KINGDOM:  
3,941,672, INT. CL. 30.

PRESTIGE PRODUCTS, INC., OMAHA, NE:  
2,369,544, CANC. INT. CL. 16.

PRICE KING, INC., LONG ISLAND CITY, NY:  
2,368,228, CANC. INT. CL. 35.

PRICE PUMP MANUFACTURING COMPANY, SONOMA, CA:  
3,939,518, PUB. 1-18-2011. INT. CL. 7.

PRICEWATERHOUSECOOPERS LLP, NEW YORK, NY:  
1,634,318, REN. 2-26-11. MULTIPLE CLASS, INT. CLS. 35 AND 42.  
3,940,947, PUB. 1-18-2011. INT. CL. 35.  
3,942,182, INT. CL. 9.

PRIDE PUBLICATIONS INC., ARLINGTON HEIGHTS, IL:  
3,940,243, PUB. 1-18-2011. INT. CL. 16.

PRIMAL NUTRITION, INC., MALIBU, CA:  
3,942,256, INT. CL. 5.

PRIME IMAGE DELAWARE, INC. D/B/A PRIME IMAGE, CHALFONT, PA:  
3,939,442, PUB. 1-18-2011. INT. CL. 9.

PRIMET PRECISION MATERIALS, INC., ITHACA, NY:  
3,942,024, MULTIPLE CLASS, INT. CLS. 1, 40 AND 42.

PRIMORIS ENERGY SOLUTIONS INC., NIWOT, CO:  
3,941,489, INT. CL. 37.

PRINTABLE TECHNOLOGIES INC., SOLANA BEACH, CA:  
3,939,560, PUB. 1-18-2011. INT. CL. 42.

PRIORITY PUBLICATIONS INC., MINNEAPOLIS, MN, DBA PRIORITY PUBLISHING MARKETING INTERACTIVE:  
3,724,705, COR. INT. CL. 35.

PRO FOOD INC., NORTHRIDGE, CA:  
2,864,957, CANC. INT. CL. 29.

PROCON FLEET SERVICES, LLC, KNOXVILLE, TN:  
3,941,658, INT. CL. 9.

PROCTER & GAMBLE COMPANY, CINCINNATI, OH:  
3,941,985, INT. CL. 3.

PROCTER & GAMBLE COMPANY, THE, CINCINNATI, OH:  
2,369,481, CANC. INT. CL. 3.  
2,450,107, REN. 2-25-11. INT. CL. 21.  
3,941,539, INT. CL. 16.  
3,941,545, INT. CL. 16.

PRODUBAN SERVICIOS INFORMATICOS GENERALES, S.L., MADRID, SPAIN:  
3,940,148, PUB. 1-18-2011. MULTIPLE CLASS, INT. CLS. 9, 35, 36, 38 AND 42.

PRODUCT INNOVATIONS RESEARCH LLC, DALLAS, TX:  
3,941,436, INT. CL. 3.

PRODUCT SAFETY CONSULTING, INC., BENSENVILLE, IL:  
3,940,638, PUB. 1-18-2011. INT. CL. 42.  
3,940,649, PUB. 1-18-2011. INT. CL. 42.

PRODUCTION PARTNERS, INC., BURBANK, CA:  
2,429,033, REN. 2-26-11. INT. CL. 41.

PRODUCTION RESOURCE GROUP, L.L.C., NEW WINDSOR, NY:  
3,939,490, PUB. 1-18-2011. MULTIPLE CLASS, INT. CLS. 6, 7, 11, 19, 20, 37, 41 AND 42.

PRODUTTORI LATTE ASSOCIATI CREMONA -; SOC. COOP. AGRICOLA (P.L.A.C.), ITALY:  
3,940,008, PUB. 1-18-2011. INT. CL. 29.

PROENZA SCHOULER, LLC, NEW YORK, NY:  
3,940,792, PUB. 1-18-2011. MULTIPLE CLASS, INT. CLS. 14 AND 18.

PROEX PHYSICAL THERAPY, LLC., KITTEERY, ME:  
3,941,119, MULTIPLE CLASS, INT. CLS. 16, 41 AND 44.

PROFESSIONAL BEAUTY ASSOCIATION, SCOTTSDALE, AZ:  
3,942,384, INT. CL. 35.

PROFESSIONAL DENTAL TECHNOLOGIES, INC., BATESVILLE, AR:  
2,369,426, CANC. INT. CL. 41.

PROGRESSIVE CHANGE CAMPAIGN COMMITTEE, WASHINGTON, DC:  
3,940,430, PUB. 1-18-2011. INT. CL. 35.

PROGRESSIVE GROUP ALLIANCE, LLC, RICHMOND, VA:  
2,864,238, CANC. INT. CL. 35.

PROGRESSIVE MEDICAL APPLICATIONS CORPORATION, ALLENTOWN, PA:  
2,368,127, CANC. INT. CL. 10.  
2,368,128, CANC. INT. CL. 10.

PROHERANT HEALTH, INC., OVERLAND PARK, KS:  
3,941,228, MULTIPLE CLASS, INT. CLS. 35, 41 AND 42.

PROMARK BRANDS INC., MERIDIAN, ID:  
3,939,679, PUB. 1-18-2011. INT. CL. 30.

PROMETHEAN LIMITED, BLACKBURN, LANCASHIRE, UNITED KINGDOM:  
3,939,452, PUB. 1-18-2011. INT. CL. 9.

PROPARK, INC., HARTFORD, CT:  
3,941,681, MULTIPLE CLASS, INT. CLS. 9 AND 37.  
3,941,682, MULTIPLE CLASS, INT. CLS. 9 AND 37.

PROPICK RACING, LLC, HENDERSON, NV:  
3,939,712, PUB. 1-18-2011. INT. CL. 41.

PROTENTIAL LLC, WOODBRIDGE, IL:  
2,538,250, REN. 2-26-11. INT. CL. 35.

PROTOCOL & DIPLOMACY INTERNATIONAL - PROTOCOL OFFICERS ASSOCIATION (PDI-POA), PLAYA DEL REY, CA:  
3,939,617, PUB. 1-18-2011. INT. CL. 41.

PROVELL, INC., MINNEAPOLIS, MN:  
3,941,866, INT. CL. 35.

PROVIDENCE PUBLICATIONS, LLC, GRANITE BAY, CA:  
3,939,497, PUB. 1-18-2011. MULTIPLE CLASS, INT. CLS. 36, 41, 44 AND 45.  
3,939,498, PUB. 1-18-2011. MULTIPLE CLASS, INT. CLS. 36, 38, 41, 44 AND 45.

PROVO CRAFT AND NOVELTY, INC., SOUTH JORDAN, UT:  
3,941,090, INT. CL. 16.

PRUDENT MAN ANALYSIS, INC., NAPERVILLE, IL:  
3,939,513, PUB. 1-18-2011. INT. CL. 36.

PRYSMIAN CAVI E SISTEMI ENERGIA SRL, MILAN, ITALY:  
2,839,487, CANC. MULTIPLE CLASS, INT. CLS. 7, 9 AND 17.

PUBCOMPANY S.R.L., ALBIGNASEGO (PD), ITALY:  
3,941,241, INT. CL. 9.

PUJOL, JAIME, MIAMI, FL:  
3,941,290, MULTIPLE CLASS, INT. CLS. 24 AND 41.

PULLMAN-HOLT CORPORATION, TAMPA, FL:  
3,940,394, PUB. 1-18-2011. INT. CL. 7.

PULP STUDIO, INC., LOS ANGELES, CA:  
3,941,165, INT. CL. 37.

PURAFLOW, INC., TEMECULA, CA:  
3,942,136, INT. CL. 11.

PURE AND SECURE LLC, LINCOLN, NE:  
3,939,509, PUB. 1-18-2011. MULTIPLE CLASS, INT. CLS. 7 AND 11.

PURE INVENTIONS, LLC, LITTLE SILVER, NJ:  
3,940,362, PUB. 1-18-2011. INT. CL. 32.

PUREPLAY LLC, GARDEN CITY, NY:  
3,942,375, INT. CL. 25.

- PURITY PRODUCTS, INC., PLAINVIEW, NY:  
3,941,329, INT. CL. 5.
- PUROLATOR EFP, LLC, HOUSTON, TX:  
3,941,848, INT. CL. 6.
- PUSHKIN, KENNETH, SANTA FE, NM:  
3,940,981, INT. CL. 38.
- PUSSEY'S (2001) LTD., TORTOLA, BR. VIRGIN ISLANDS:  
3,940,146, PUB. 1-18-2011. MULTIPLE CLASS, INT. CLS. 18, 21, 24, 29 AND 30.  
3,940,458, PUB. 1-18-2011. MULTIPLE CLASS, INT. CLS. 3 AND 14.
- PWP PRODUCTIONS LLC, TENAFLY, NJ:  
3,941,942, MULTIPLE CLASS, INT. CLS. 41 AND 45.
- Q MED, INC., LAURENCE HARBOR, NJ:  
1,577,416, CANC. MULTIPLE CLASS, INT. CLS. 9 AND 10.
- Q PHARMACY, INC., SAN ANTONIO, TX:  
3,942,062, INT. CL. 35.
- QEF DESIGN CORP., YONGHE CITY, TAIPEI CO, TAIWAN:  
3,942,200, INT. CL. 9.
- QEP - TENNESSEE, INC., BOCA RATON, FL:  
3,939,682, PUB. 1-18-2011. INT. CL. 19.
- QFC ASSOCIATES, LLC, JAMAICA, NY:  
3,940,646, PUB. 1-18-2011. MULTIPLE CLASS, INT. CLS. 36, 37 AND 45.  
3,940,652, PUB. 1-18-2011. MULTIPLE CLASS, INT. CLS. 36, 37 AND 45.
- QMED, INC., LAURENCE HARBOR, NJ:  
2,865,493, CANC. INT. CL. 44.
- QNOMY INC, NEW YORK, NY:  
3,941,716, INT. CL. 9.
- QT2 SYSTEMS, WEST ROXBURY, MA:  
3,939,835, PUB. 1-18-2011. INT. CL. 44.
- QUAIL HOLLOW COUNTRY CLUB, CHARLOTTE, NC:  
3,939,527, PUB. 1-18-2011. MULTIPLE CLASS, INT. CLS. 35 AND 41.
- QUALCOMM INCORPORATED, SAN DIEGO, CA:  
3,941,952, INT. CL. 41.  
3,942,034, INT. CL. 9.  
3,942,035, INT. CL. 9.
- QUALIMAE CORP., MIAMI, FL:  
3,940,178, PUB. 1-18-2011. INT. CL. 35.
- QUALITY BICYCLE PRODUCTS, INC., BLOOMINGTON, MN:  
3,942,254, INT. CL. 35.
- QUALITY CERTIFICATION, LLC, WOODINVILLE, WA:  
3,939,541, PUB. 1-18-2011. INT. CL. 42.
- QUANT HOUSE SAS, FRANCE:  
3,940,043, PUB. 1-18-2011. MULTIPLE CLASS, INT. CLS. 38 AND 42.
- QUARTZ ELECTRONICS LTD., READING, UNITED KINGDOM:  
2,864,398, CANC. INT. CL. 9.
- QUEEN VIC, LLC, WASHINGTON, DC, DBA THE QUEEN VIC:  
3,940,763, PUB. 1-18-2011. INT. CL. 43.
- QUEST CHEMICAL CORPORATION, HOUSTON, TX:  
2,865,384, CANC. INT. CL. 3.
- QUEST INTERNATIONAL BV, 1411 GP NAARDEN, NETHERLANDS:  
2,863,991, CANC. MULTIPLE CLASS, INT. CLS. 1, 3 AND 30.
- QUICK TEL, INC, ELIZABETH, NJ:  
2,865,521, CANC. MULTIPLE CLASS, INT. CLS. 16, 36 AND 38.
- QUIKSILVER AMERICAS, INC., HUNTINGTON BEACH, CA:  
2,432,325, REN. 3-2-11. INT. CL. 28.
- QUILVEST, L-1660 LUXEMBOURG, LUXEMBOURG:  
2,430,605, REN. 3-1-11. INT. CL. 36.
- QUIN, SUSAN M, WOODBURY HEIGHTS, NJ:  
3,941,087, INT. CL. 25.
- QUITE A LADY, INC., FT PIERCE, FL:  
2,864,601, CANC. INT. CL. 43.
- QUOTABLE CARDS, INC., NEW YORK, NY:  
2,368,546, CANC. INT. CL. 16.
- QUOTABLES UNLIMITED, TROY, OH:  
2,368,438, CANC. INT. CL. 16.
- QUOTABLES UNLIMITED, INC, TROY, OH:  
2,368,740, CANC. INT. CL. 16.  
2,368,741, CANC. INT. CL. 16.  
2,368,742, CANC. INT. CL. 16.
- QUOTEWIZARD.COM, LLC, SEATTLE, WA:  
3,940,801, PUB. 1-18-2011. INT. CL. 35.
- QVC, INC., WEST CHESTER, PA:  
2,437,241, REN. 2-25-11. INT. CL. 24.
- R & B WIRE PRODUCTS, INC., SANTA ANA, CA:  
2,430,940, REN. 3-3-11. MULTIPLE CLASS, INT. CLS. 6, 9, 12 AND 20.
- R SYSTEMS INCORPORATED, EL DORADO HILLS, CA:  
2,527,598, CANC. INT. CL. 42.
- R.A.C. MEDICAL GROUP, INC., BOCA RATON, FL:  
2,865,080, CANC. INT. CL. 5.
- R&J NUTRACEUTICALS INC., WOODBRIDGE, ONTARIO, CANADA:  
3,939,589, PUB. 1-18-2011. INT. CL. 44.
- RABENS ATELIER A/S, DENMARK:  
3,940,037, PUB. 1-18-2011. MULTIPLE CLASS, INT. CLS. 20, 23 AND 35.
- RACHEL ARAM, SAN FRANCISCO, CA:  
3,942,461, INT. CL. 41.
- RACING RADIOS, INC., FOREST PARK, GA:  
2,368,429, CANC. MULTIPLE CLASS, INT. CLS. 9 AND 41.
- RADIALPOINT SAFECARE INC., MONTREAL, CANADA:  
2,367,806, CANC. INT. CL. 9.
- RADIANT COMMUNICATIONS CORPORATION, SOUTH PLAINFIELD, NJ:  
3,939,453, PUB. 1-18-2011. INT. CL. 9.
- RAISED FIST INC., MALVERNE, NY:  
3,940,894, PUB. 1-18-2011. INT. CL. 25.
- RAKA CREATIVE, LLC, PORTSMOUTH, NH:  
3,940,339, PUB. 1-18-2011. INT. CL. 35.
- RALSTON-PAYNE ENTERPRISES, LLC, RICHMOND, VA:  
3,940,116, PUB. 1-18-2011. MULTIPLE CLASS, INT. CLS. 35 AND 41.
- RAMCO MANUFACTURING COMPANY, INC., KENILWORTH, NJ:  
1,652,997, REN. 2-26-11. INT. CL. 11.
- RAMOS, MANUEL, NORWALK, CT:  
3,940,837, PUB. 1-18-2011. INT. CL. 25.
- RAMSEY POPCORN CO., INC., RAMSEY, IN:  
1,161,210, REN. 2-25-11. INT. CL. 31.
- RANDOM HOUSE, INC., NEW YORK, NY:  
3,941,523, INT. CL. 16.
- RANGEL, RANDY, HOUSTON, TX:  
3,940,753, PUB. 1-18-2011. INT. CL. 25.
- RANPAK CORP., CONCORD TOWNSHIP, OH:  
2,367,919, CANC. INT. CL. 16.
- RANSTAD GROUP INC, EUGENE, OR:  
3,942,470, INT. CL. 36.
- RAPP COLLINS WORLDWIDE INC., NEW YORK, NY:  
3,941,128, MULTIPLE CLASS, INT. CLS. 35, 39, 41 AND 42.
- RAQUEL CONTRERAS, OAKLAND, CA, DBA TAMÁLAGO CAFÉ:  
3,940,267, PUB. 1-18-2011. INT. CL. 30.
- RATH, DR. MATTHIAS, CAPE TOWN, SOUTH AFRICA:  
3,939,433, PUB. 1-18-2011. MULTIPLE CLASS, INT. CLS. 9, 16, 41 AND 44.
- RAVE LLC, DELRAY BEACH, FL:  
3,940,192, PUB. 1-18-2011. INT. CL. 9.
- RAY CHILDRESS AUTO GROUP, INC., THE, HOUSTON, TX:  
2,368,293, CANC. MULTIPLE CLASS, INT. CLS. 35 AND 37.
- RAY GRIFFITHS, INC., NEW YORK, NY:  
3,939,359, PUB. 1-18-2011. INT. CL. 14.
- RAYNOR CANADA CORP., MISSISSAUGA, CANADA:  
3,941,020, MULTIPLE CLASS, INT. CLS. 6 AND 19.
- RAYTHEON COMPANY, WALTHAM, MA:  
3,942,043, INT. CL. 9.
- RAYTHEON SARCOS, LLC, WALTHAM, MA:  
2,369,240, CANC. INT. CL. 9.
- READY TO RUMBLE, LLC, LOS ANGELES, CA:  
2,405,492, REN. 3-3-11. MULTIPLE CLASS, INT. CLS. 35

AND 41.  
REAL MEDICINE INC., STUDIO CITY, CA:  
3,939,503, PUB. 1-18-2011. MULTIPLE CLASS, INT. CLS.  
41 AND 44.  
REAL PROPERTY MANAGEMENT, INC., LAYTON, UT:  
3,942,383, INT. CL. 36.  
REAL WEALTH RADIO, LLC, KEWASKUM, WI:  
3,942,249, MULTIPLE CLASS, INT. CLS. 9 AND 36.  
REALCME, INC., NEW YORK, NY:  
3,941,356, INT. CL. 35.  
REALITY MANAGEMENT GROUP, INC., PHOENIX, AZ:  
2,368,019, CANC. MULTIPLE CLASS, INT. CLS. 9 AND  
16.  
REALM, LLC, VAN NUYS, CA:  
3,940,953, PUB. 1-18-2011. INT. CL. 41.  
REALPOINT LLC, A PENNSYLVANIA LIMITED LIABILITY  
COMPANY, HORSHAM, PA:  
2,633,053, CANC. INT. CL. 36.  
REALTYINFUSION.COM, INC., SEMINOLE, FL:  
3,941,765, MULTIPLE CLASS, INT. CLS. 36 AND 42.  
RECKITT & COLMAN (OVERSEAS) LIMITED, HULL,  
UNITED KINGDOM:  
3,940,269, PUB. 1-18-2011. MULTIPLE CLASS, INT. CLS. 3  
AND 5.  
RECKITT BENCKISER LLC, PARSIPPANY, NJ:  
3,906,293, CANC. INT. CL. 3.  
RED & WHITE FLEET EXCURSIONS, INC., SAN FRANCIS-  
CO, CA:  
2,462,035, REN. 3-1-11. INT. CL. 39.  
RED BUD RECREATION, INC., BUCHANAN, MI, AKA  
REDBUD MX:  
2,408,028, REN. 3-2-11. INT. CL. 41.  
RED BULL GMBH, 5330 FUSCHL AM SEE, AUSTRIA:  
3,939,863, PUB. 9-4-2007. INT. CL. 32.  
RED DEVIL, INC., TULSA, OK:  
2,864,042, CANC. INT. CL. 17.  
RED RIVER REVEL, SHREVEPORT, LA:  
1,636,407, REN. 2-25-11. INT. CL. 41.  
REDEEMER CITYNET, NEW YORK, NY:  
3,941,460, INT. CL. 41.  
REDENBACHER, GARY FISH, SCOTTS VALLEY, CA:  
3,941,973, INT. CL. 41.  
REDLINE PRODUCTS PTY LTD, CAPE TOWN, SOUTH  
AFRICA:  
3,940,684, PUB. 1-18-2011. INT. CL. 10.  
REDVECTOR.COM, INC., TAMPA, FL:  
2,539,845, REN. 2-26-11. INT. CL. 41.  
REED AND BARTON CORPORATION, TAUNTON, MA:  
1,640,256, REN. 3-3-11. INT. CL. 8.  
REED ELSEVIER INC., NEWTON, MA:  
3,941,472, INT. CL. 35.  
REEDER, FREDRICK ARLEN, WINCHESTER, MA:  
1,549,581, CANC. INT. CL. 42.  
REFINED TECHNOLOGIES, INC., SPRING, TX:  
2,457,143, REN. 2-26-11. INT. CL. 3.  
REFLEX SYSTEMS LLC, ATLANTA, GA:  
3,941,855, INT. CL. 9.  
REGAL WARE, INC., KEWASKUM, WI:  
2,533,308, REN. 2-26-11. INT. CL. 11.  
REGENTS OF THE UNIVERSITY OF MINNESOTA, MIN-  
NEAPOLIS, MN:  
2,864,996, CANC. INT. CL. 42.  
REGIS INSURANCE COMPANY, BERWYN, PA:  
2,368,366, CANC. INT. CL. 36.  
REHAU INCORPORATED, LEESBURG, VA:  
2,434,101, REN. 2-26-11. INT. CL. 11.  
RELCO CORP., EXETER, PA:  
2,489,666, CANC. INT. CL. 35.  
RELIANCE ENTERPRISE CORP., TAIPIN, TAIWAN, CHI-  
NA:  
2,369,093, CANC. MULTIPLE CLASS, INT. CLS. 6 AND  
20.  
RELIANT ENERGY RETAIL HOLDINGS, LLC, HOUSTON,  
TX:  
3,942,290, INT. CL. 39.  
RELIANT ENERGY, INC., HOUSTON, TX:  
2,865,827, CANC. MULTIPLE CLASS, INT. CLS. 16 AND  
41.  
RELUME TECHNOLOGIES, INC., OXFORD, MI:  
3,941,802, INT. CL. 9.  
REMEDY ROOFING, INC., KATY, TX:  
3,940,871, PUB. 1-18-2011. INT. CL. 37.  
REMEMBER2REMEMBER, INC., MARIETTA, GA:  
3,941,666, INT. CL. 21.  
3,941,667, INT. CL. 21.  
3,941,668, INT. CL. 21.  
3,941,669, INT. CL. 21.  
3,941,670, INT. CL. 21.  
3,941,671, INT. CL. 21.  
3,941,679, INT. CL. 21.  
3,941,687, INT. CL. 21.  
REMEY ROZIN, CHICAGO, IL:  
3,939,834, PUB. 1-18-2011. INT. CL. 25.  
REMINGTON HEALTH PRODUCTS, LLC, FORT WORTH,  
TX:  
2,865,336, CANC. INT. CL. 5.  
REMPREX, LLC, CHARLOTTE, NC:  
3,940,514, PUB. 1-18-2011. INT. CL. 45.  
RENAULT S.A.S., 92100 BOULOGNE-BILLANCOURT,  
FRANCE:  
2,863,930, CANC. INT. CL. 12.  
2,863,931, CANC. INT. CL. 12.  
RENERGY CAPITAL LLC, BARRINGTON HILLS, IL:  
3,942,276, INT. CL. 36.  
3,942,277, INT. CL. 36.  
RENKARA MEDIA GROUP, INVERNESS, IL:  
3,939,763, PUB. 1-18-2011. INT. CL. 9.  
RENNSTEIG WERKZEUGE GMBH, VIERNAU, FED REP  
GERMANY:  
3,939,525, PUB. 1-18-2011. MULTIPLE CLASS, INT. CLS.  
7, 8, 9 AND 20.  
RENTRAK CORPORATION, PORTLAND, OR:  
1,594,594, AM. INT. CL. 41.  
REPAIRSTADT, INC., SWAMPSCOTT, MA:  
3,941,576, INT. CL. 42.  
RESA WILSON BAZILE, NEW ORLEANS, LA:  
3,939,865, PUB. 1-18-2011. INT. CL. 41.  
RESMED LIMITED, BELLA VISTA NSW, AUSTRALIA:  
3,939,489, PUB. 1-18-2011. INT. CL. 10.  
RESONATE, INC., CINCINNATI, OH:  
2,865,770, CANC. MULTIPLE CLASS, INT. CLS. 16 AND  
41.  
RESPONSE DESIGN CORPORATION, OCEAN CITY, NJ:  
2,368,048, CANC. MULTIPLE CLASS, INT. CLS. 16 AND  
41.  
2,368,049, CANC. INT. CL. 41.  
2,368,050, CANC. INT. CL. 41.  
RESPONSYS, INC., SAN BRUNO, CA:  
2,426,163, REN. 3-2-11. INT. CL. 42.  
RESTORATION HARDWARE, INC., CORTE MADERA, CA:  
2,864,126, CANC. MULTIPLE CLASS, INT. CLS. 24, 25  
AND 27.  
RESTORE COMMUNITY CHURCH, KANSAS CITY, MO:  
3,940,513, PUB. 1-18-2011. INT. CL. 45.  
REUNIONDB, INC., RANCHO SANTA FE, CA:  
3,942,449, INT. CL. 42.  
REVENUE FRONTIER, LLC, SANTA MONICA, CA:  
3,941,714, INT. CL. 9.  
REXALL SUNDOWN, INC., RONKONKOMA, NY:  
2,473,394, REN. 2-26-11. INT. CL. 5.  
REYNOLDS POLYMER TECHNOLOGY, INC., GRAND  
JUNCTION, CO, DBA R-CAST:  
3,939,857, PUB. 1-18-2011. INT. CL. 17.  
REZNICK GROUP P.C., BETHESDA, MD:  
3,672,322, CANC. MULTIPLE CLASS, INT. CLS. 35 AND  
36.  
REZNIK CORPORATION, MINNETONKA, MN, DBA  
BOOMERANG PAYS:  
3,939,627, PUB. 1-18-2011. INT. CL. 35.  
RHEON JIDOKI KABUSHIKI KAISHA, UTSUNOMIYA  
CITY, TOCHIGI PREFECTURE, JAPAN, DBA RHEON  
AUTOMATIC MACHINERY CO., LTD.:  
2,465,412, REN. 2-26-11. INT. CL. 7.  
RHO, INC., CHAPEL HILL, NC:  
3,939,521, PUB. 1-18-2011. MULTIPLE CLASS, INT. CLS.

- 35, 41 AND 42.  
3,939,522, PUB. 1-18-2011. MULTIPLE CLASS, INT. CLS. 35, 41 AND 42.
- RHYTHM HOLDING LIMITED, HONG KONG, HONG KONG:  
3,942,010, MULTIPLE CLASS, INT. CLS. 18 AND 25.
- RIAENJOLIE, INC., PLAINSBORO, NJ:  
3,942,117, INT. CL. 9.
- RIC INVESTMENTS, LLC, WILMINGTON, DE:  
2,434,153, REN. 3-2-11. INT. CL. 10.
- RICE, ALISON J., RICHWOOD, TX:  
2,368,313, CANC. INT. CL. 42.
- RICE, CURTIS D., JR, NORTH LITTLE ROCK, AR:  
3,941,735, INT. CL. 25.
- RICE, MARK, ALPHARETTA, GA:  
2,374,943, REN. 2-26-11. INT. CL. 28.  
2,423,906, REN. 2-25-11. INT. CL. 28.  
2,437,486, REN. 2-25-11. INT. CL. 28.
- RICHARD J. CARON FOUNDATION, WERNERSVILLE, PA:  
3,939,677, PUB. 1-18-2011. INT. CL. 44.
- RICHARDS, JENIECE M., LAS VEGAS, NV:  
2,865,609, CANC. INT. CL. 25.
- RICHFOOD, INC., RICHMOND, VA:  
2,864,804, CANC. MULTIPLE CLASS, INT. CLS. 29, 30 AND 32.
- RICHOOM CORP., NEW YORK, NY:  
3,941,938, INT. CL. 24.
- RICHMOND PLYWOOD CORPORATION LIMITED, RICHMOND, CANADA:  
3,942,366, INT. CL. 19.
- RICKER OIL COMPANY, INC., ANDERSON, IN:  
3,940,588, PUB. 1-18-2011. INT. CL. 35.
- RIFF, JONATHAN, LAGUNA BEACH, CA:  
3,940,797, PUB. 1-18-2011. INT. CL. 25.
- RIGHT START ACQUISITION COMPANY, SANTA BARBARA, CA:  
2,368,955, CANC. INT. CL. 25.
- RIGHTPATH RESOURCES, INC., ATLANTA, GA:  
2,864,262, CANC. INT. CL. 35.
- RIGID, INC., WILMINGTON, DE TO RIGID, INC., WILMINGTON, DE:  
2,420,497, AM. MULTIPLE CLASS, INT. CLS. 7 AND 11.
- RIO PERLA PROPERTIES, L.P., SAN ANTONIO, TX:  
3,941,365, INT. CL. 37.  
3,941,367, INT. CL. 37.
- RIPALTA S.N.C. DI MARCUZZI CLAUDIA E SUTOR ARMANDO, TREVISO, ITALY:  
2,369,007, CANC. MULTIPLE CLASS, INT. CLS. 19 AND 27.
- RIRI GROUP SA, 6850 MENDRISIO, SWITZERLAND:  
2,864,777, CANC. INT. CL. 26.
- RITA RESTAURANT CORP., MADISON, GA:  
3,941,077, INT. CL. 35.
- RITA'S PROPERTIES, INC., TREVISO, PA:  
2,865,334, CANC. INT. CL. 35.
- RITA'S WATER ICE FRANCHISE COMPANY, LLC, TREVISO, PA:  
3,941,912, INT. CL. 30.
- RITCHIE, FIONA, MATTHEWS, NC, UNIVERSITY OF NORTH CAROLINA AT CHARLOTTE, THE, CHARLOTTE, NC:  
1,636,968, REN. 2-26-11. INT. CL. 25.
- RITENOUR, JASON S, AUSTIN, TX:  
2,864,925, CANC. MULTIPLE CLASS, INT. CLS. 9, 35 AND 42.
- RIU HOTELS, S.A., BALEARIC ISLANDS, SPAIN:  
2,435,753, REN. 2-26-11. INT. CL. 42.
- RIVALROO, INC., IRVING, TX:  
3,940,552, PUB. 1-18-2011. INT. CL. 38.
- RIVENBARK, DARREN NEIL, BELLFLOWER, CA:  
2,368,276, CANC. INT. CL. 28.
- RIVER CITY DIESEL, LLC, EAST PEORIA, IL:  
3,939,688, PUB. 1-18-2011. INT. CL. 7.
- RIVER ROCK TEXTILES & APPARELS INC., ONTARIO L5W 1K8, CANADA:  
2,864,271, CANC. INT. CL. 25.  
2,864,272, CANC. INT. CL. 25.
- RIVER VALLEY FLOWERS, LLC, MIAMI, FL:  
2,865,206, CANC. INT. CL. 31.
- RJ LEE GROUP, INC., MONROEVILLE, PA:  
2,381,680, REN. 2-26-11. INT. CL. 9.
- RJ MILANO, NAPERVILLE, IL:  
3,941,450, INT. CL. 43.
- RLISYS SOFTWARE SOLUTIONS, INC., MELVILLE, NY:  
2,864,336, CANC. INT. CL. 9.
- RMAX, LLC, WAIALUA, HI:  
2,865,108, CANC. INT. CL. 9.
- RME, LLC, TAMPA, FL:  
3,941,723, INT. CL. 35.
- ROARING BROOK ART COMPANY, INC., HARTSDALE, NY:  
3,940,501, PUB. 1-18-2011. INT. CL. 35.
- ROBBIE MANUFACTURING, INC., LENEXA, KS:  
3,941,966, INT. CL. 35.
- ROBBINS & MYERS, INC., DAYTON, OH:  
2,451,435, REN. 3-2-11. MULTIPLE CLASS, INT. CLS. 7 AND 17.
- ROBBINS, JOHN P., LITTLE FALLS, MN:  
2,864,149, CANC. INT. CL. 17.
- ROBERT CISHECKI, TORONTO, CANADA, DBA MILK & COOKIES CLOTHING COMPANY:  
3,940,342, PUB. 1-18-2011. INT. CL. 25.
- ROBERT HALF INTERNATIONAL INC., MENLO PARK, CA:  
2,431,669, REN. 2-26-11. INT. CL. 35.
- ROBERT J. THOMPSON, BOWIE, MD, DBA RETRO DELUXE:  
3,941,394, INT. CL. 9.
- ROBERT KIENZTY, TROY, MO, DBA KIENZTY MACHINE COMPANY:  
2,424,108, REN. 3-3-11. INT. CL. 11.
- ROBERT ROTHSCHILD FARM, LLC, URBANA, OH:  
3,855,685, COR. MULTIPLE CLASS, INT. CLS. 29 AND 30.
- ROBERTSON PRESS MACHINERY COMPANY, INC, WEBB CITY, MO:  
1,632,165, REN. 3-2-11. INT. CL. 7.
- ROBICRAN INNOVATIONS, L.L.C., INMAN, SC:  
2,864,134, CANC. INT. CL. 9.
- ROBIN STÄDLER, SWITZERLAND:  
3,940,060, PUB. 1-18-2011. MULTIPLE CLASS, INT. CLS. 28 AND 41.
- ROCK BOTTOM RESTAURANTS, INC., LOUISVILLE, CO:  
3,939,593, PUB. 1-18-2011. INT. CL. 41.
- ROCK OF AGES CORPORATION, GRANITEVILLE, VT:  
715,541, REN. 2-26-11. U.S. CL. 50 (INT. CL. 19).
- ROCKBROOK VILLAGE SHOPPING CENTER, INC., OMAHA, NE:  
2,429,746, REN. 3-3-11. INT. CL. 36.
- ROCKET ENTERPRISE, INC., WARREN, MI:  
2,442,286, REN. 2-26-11. INT. CL. 37.
- ROCKWELL AUTOMATION, INC., MILWAUKEE, WI, ALLEN-BRAD;EU COMPANY, MILWAUKEE, WI:  
712,836, REN. 2-25-11. U.S. CL. 26 (INT. CL. 9).
- ROCKY BRANDS, INC., NELSONVILLE, OH:  
3,941,400, INT. CL. 25.
- ROCKY MOUNTAIN TENNIS CLUBS, LLC, BOULDER, CO:  
3,941,054, INT. CL. 41.
- ROCKY MOUNTAIN VETERINARY NEUROLOGY, LLC, ENGLEWOOD, CO:  
3,941,577, INT. CL. 31.
- ROCTEST LTD., VANCOUVER, BRITISH COLUMBIA, CANADA:  
3,942,346, INT. CL. 45.
- RODALE PRESS, INC., EMMAUS, PA TO WORLD PUBLICATIONS, LLC, WINTER PARK, FL:  
1,759,846, CANC. INT. CL. 16.
- RODEY, DICKASON, SLOAN, AKIN & ROBB, P.A., ALBUQUERQUE, NM:  
2,498,198, REN. 3-2-11. INT. CL. 42.
- RODOLFO SEALTIEL RIVA PALACIO ALATRISTE, MEXICO, D.F., MEXICO AND GABRIEL ENRIQUE RIVA PALACIO ALATRISTE, MEXICO, D.F., MEXICO:  
3,475,156, COR. MULTIPLE CLASS, INT. CLS. 38 AND 41.

ROESCH, DEBRA, PENDLETON, OR:  
3,941,685, INT. CL. 32.

ROG, INC., CAMBRIDGE, MA:  
2,347,192, CANC. MULTIPLE CLASS, INT. CLS. 35 AND 42.

ROGERS ATHLETIC COMPANY, INC., CLARE, MI:  
3,939,460, PUB. 1-18-2011. INT. CL. 28.

ROHM AND HAAS COMPANY, PHILADELPIA, PA, SHIPLEY COMPANY INC., NEWTON, MA:  
1,632,815. REN. 2-25-11. INT. CL. 1.

ROHM AND HAAS COMPANY, PHILADELPHIA, PA:  
2,433,164. REN. 2-26-11. MULTIPLE CLASS, INT. CLS. 16 AND 41.

ROLEX WATCH U.S.A., INC., NEW YORK, NY:  
2,950,028, COR. INT. CL. 14.  
2,953,542, COR. INT. CL. 14.

RONVIL II, INC., RIVIERA BEACH, FL, DBA COSTELLO'S PIZZERIA & TRATTORIA:  
2,864,575, CANC. INT. CL. 43.

ROOMATIONS LLC, CINCINNATI, OH:  
3,942,002, INT. CL. 42.

ROOTSTOCK WINE & BEER BAR LLC, CHICAGO, IL:  
3,939,821, PUB. 1-18-2011. INT. CL. 43.

ROQUETTE & CAZES, LDA, PORTUGAL:  
3,940,064, PUB. 1-18-2011. INT. CL. 33.

ROSE, JOHN EDWARD, BERKSHIRE, UNITED KINGDOM:  
2,432,496. REN. 2-28-11. MULTIPLE CLASS, INT. CLS. 9 AND 10.

ROSENBAUM, SUE, OCEANSIDE, NY:  
3,940,821, PUB. 1-18-2011. INT. CL. 45.

ROSENBERG, GERALD, BOCA RATON, FL AND ROSENBERG, KENNETH, NEW YORK, NY:  
3,941,599, INT. CL. 32.

ROSETREE, ROSE, STERLING, VA:  
3,941,125, MULTIPLE CLASS, INT. CLS. 41 AND 45.

ROSS OUTDOOR SPORTS SPECIALTIES, LLC, MONTROSE, CO:  
3,940,731, PUB. 1-18-2011. INT. CL. 28.  
3,940,734, PUB. 1-18-2011. INT. CL. 28.

ROSS, GREG, FORT LAUDERDALE, FL:  
3,628,947, CANC. INT. CL. 42.

ROSSWIL, LLC, MEMPHIS, TN:  
2,438,712. REN. 2-26-11. INT. CL. 34.

ROTELLI PIZZA & PASTA, INC., BOCA RATON, FL:  
3,942,050, INT. CL. 43.

ROTH & RAU AG, FED REP GERMANY:  
3,940,061, PUB. 1-18-2011. MULTIPLE CLASS, INT. CLS. 7, 9 AND 40.

ROUND ROCK BASEBALL, INC., ROUND ROCK, TX:  
2,433,005. REN. 3-2-11. MULTIPLE CLASS, INT. CLS. 14, 16, 25 AND 28.

ROUSSO APPAREL GROUP, INC., NEW YORK, NY:  
2,428,905. REN. 2-28-11. INT. CL. 25.

ROUTE ONE INVESTMENT COMPANY, L.P., SAN FRANCISCO, CA:  
3,940,961, PUB. 1-18-2011. INT. CL. 36.

ROUTIN, FRANCE:  
3,324,826, COR. INT. CL. 32.

ROXANNE EMMERICH, EDEN PRAIRIE, MN:  
3,941,062, INT. CL. 35.

ROYAL BLUE STAR INTERNATIONAL, INC., BAYSIDE, NY:  
3,940,325, PUB. 1-18-2011. INT. CL. 30.

ROYAL OPERA HOUSE COVENT GARDEN; LIMITED, LONDON WC2E 9DD, UNITED KINGDOM:  
3,939,913, PUB. 1-18-2011. MULTIPLE CLASS, INT. CLS. 3, 9, 16, 18, 21, 25, 30, 38 AND 41.

ROYAL SHELL VACATIONS, INC., SANIBEL ISLAND, FL:  
2,475,028. REN. 3-2-11. MULTIPLE CLASS, INT. CLS. 35 AND 42.

ROYAL WINE CORPORATION DBA HERZOG WINE CELLARS, BAYONNE, NJ:  
3,942,466, INT. CL. 41.

ROYAL WULFF PRODUCTS, INC., LIVINGSTON MANOR, NY:  
3,939,385, PUB. 1-18-2011. INT. CL. 28.

ROYAL YORK HOTEL LP, MISSISSAUGA, ONTARIO, CANADA:  
2,863,982, CANC. INT. CL. 43.

ROYCE TOO LLC, NEW YORK, NY:  
3,940,974, PUB. 1-18-2011. INT. CL. 25.

ROYSTON LLC, JASPER, GA:  
2,451,600. REN. 2-26-11. MULTIPLE CLASS, INT. CLS. 20 AND 21.

RSIGNIA, INC., COLUMBIA, MD:  
3,941,733, INT. CL. 9.

RT7K, LLC, SHERMAN OAKS, CA:  
3,940,442, PUB. 1-18-2011. MULTIPLE CLASS, INT. CLS. 9 AND 42.

RU OUTSIDE THE BOX?, LLC, RICHMOND, RI:  
3,941,333, INT. CL. 25.

RUBANOWITZ, INC, WEST HILLS, CA:  
3,939,533, PUB. 1-18-2011. INT. CL. 43.

RUBEN'S INC., NEW YORK, NY:  
2,529,592. REN. 2-26-11. INT. CL. 30.

RUBIN, REBECCA, BIRMINGHAM, MI:  
2,864,833, CANC. INT. CL. 16.

RUBY'S DINER, INC., IRVINE, CA:  
1,611,327. REN. 2-26-11. INT. CL. 25.  
1,631,936. REN. 3-1-11. INT. CL. 42.

RUBYSNAP, LLC, SALT LAKE CITY, UT:  
3,942,286, MULTIPLE CLASS, INT. CLS. 30 AND 35.

RUSSELL STOVER CANDIES, INC., KANSAS CITY, MO:  
3,942,149, INT. CL. 30.

RUSSELL, JEFFREY L., WARREN, MI:  
3,941,106, INT. CL. 41.

RUSSOUND/FMP, INC., NEWMARKET, NH:  
3,940,276, PUB. 1-18-2011. INT. CL. 9.

RUSSTEL S.A., LTD., FLUSHING, NY:  
3,940,635, PUB. 1-18-2011. INT. CL. 38.

RUTGERS, THE STATE UNIVERSITY, NEW BRUNSWICK, NJ:  
3,939,559, PUB. 1-18-2011. INT. CL. 31.

RWG LICENSING, LLC, WINSTON-SALEM, NC:  
2,926,604, CANC. MULTIPLE CLASS, INT. CLS. 6, 16, 24 AND 31.  
2,929,280, CANC. MULTIPLE CLASS, INT. CLS. 16, 24 AND 31.

RYCAN TECHNOLOGIES, INC., MARSHALL, MN:  
2,865,239, CANC. INT. CL. 42.

RYOHIN KEIKAKU CO., LTD., TOSHIMA-KU, TOKYO, JAPAN:  
2,863,919, CANC. INT. CL. 35.

RYTEC CORPORATION, JACKSON, WI:  
3,939,719, PUB. 1-18-2011. INT. CL. 6.  
3,939,720, PUB. 1-18-2011. INT. CL. 6.

RZN NUTRACEUTICALS, INC., ORANGE PARK, FL:  
3,941,451, INT. CL. 5.

R3 DESIGN LLC, NAHANT, MA:  
3,941,580, INT. CL. 3.

S INDUSTRIES, LLC, COMMERCE, TX:  
2,864,583, CANC. INT. CL. 37.

S. C. JOHNSON & SON, INC., RACINE, WI:  
3,942,019, MULTIPLE CLASS, INT. CLS. 7, 16 AND 21.

S. G. MADISON, IRVING, TX:  
2,864,368, CANC. INT. CL. 41.

S.C. JOHNSON & SON, INC., RACINE, WI:  
2,369,502, CANC. INT. CL. 3.

S.F. DELUXE PRODUCTIONS, INC., SAN FRANCISCO, CA:  
2,432,494. REN. 2-25-11. INT. CL. 28.

S.H. MEDICAL CORPORATION, MIAMI, FL:  
3,940,870, PUB. 1-18-2011. INT. CL. 10.

S.I.C. SOCIETA' INDUSTRIA CHIMICA S.P.A., 20020 RO-BECCHETTO CON INDUNO (MILAN), ITALY:  
2,864,070, CANC. MULTIPLE CLASS, INT. CLS. 25 AND 35.

S&M BRANDS, INC., KEYSVILLE, VA:  
2,443,488. REN. 2-26-11. INT. CL. 34.

SA BERINGER, CHATELNEUF, FRANCE:  
2,359,669. REN. 3-2-11. INT. CL. 12.

SACCA, FRANK, DIAMOND BAR, CA:  
2,368,970, CANC. INT. CL. 9.

SAFARILAND, LLC, JACKSONVILLE, FL:  
2,864,627, CANC. INT. CL. 9.

- SAFE RISK MANAGEMENT SYSTEMS, LLC, BALTIMORE, MD:  
2,864,508, CANC. INT. CL. 9.
- SAFE-T-SHADE, INC., BURLINGTON, NC:  
3,942,303, INT. CL. 20.
- SAFEGUARD PROPERTIES, LLC, VALLEY VIEW, OH:  
3,940,306, PUB. 1-18-2011. INT. CL. 36.
- SAFETEC OF AMERICA, INC., BUFFALO, NY:  
2,864,394, CANC. INT. CL. 5.
- SAFILO USA, INC., PARSIPPANY, NJ:  
1,185,565, REN. 2-25-11. INT. CL. 9.
- SAGA COMMUNICATIONS OF IOWA, LLC, DES MOINES, IA:  
2,385,690, REN. 2-25-11. INT. CL. 38.
- SAGACITY, INC., BELLINGHAM, WA, DBA ABRIGE:  
2,864,873, CANC. INT. CL. 35.
- SAGE HOLDINGS GROUP, LTD., ROCHESTER HILLS, MI:  
3,942,105, MULTIPLE CLASS, INT. CLS. 44 AND 45.
- SAINT ROBERT BELLARMINI TRUST, SAGINAW, MI:  
3,939,756, PUB. 1-18-2011. INT. CL. 16.
- SAKAR INTERNATIONAL, INC., EDISON, NJ:  
2,864,682, CANC. INT. CL. 28.
- SALESIAN MISSIONS, NEW ROCHELLE, NY:  
3,939,606, PUB. 1-18-2011. MULTIPLE CLASS, INT. CLS. 36, 41, 43 AND 45.
- SALLEN, STEVEN D., SOUTHFIELD, MI:  
3,939,592, PUB. 1-18-2011. INT. CL. 36.
- SALLIE MAE, INC., RESTON, VA:  
2,367,752, CANC. INT. CL. 36.
- SALMON LLC, GARDEN CITY SOUTH, NY:  
2,864,305, CANC. INT. CL. 9.
- SALTED SOUL COMPANY, LLC, BOCA RATON, FL:  
3,941,391, INT. CL. 25.
- SALTWORKS, INC., WOODINVILLE, WA:  
3,837,418, CANC. INT. CL. 3.
- SAMEPAGE, LLC, WOOSTER, OH:  
2,368,491, CANC. INT. CL. 35.
- SAMSON, DARA, LONG BEACH, CA:  
3,940,245, PUB. 1-18-2011. INT. CL. 18.
- SAMSUNG ELECTRONICS CO., LTD., SUWON-CITY, KYUNGKI-DO, REPUBLIC OF KOREA:  
2,863,999, CANC. INT. CL. 9.
- SAMSUNG INFORMATION SYSTEMS AMERICA, INC., SAN JOSE, CA:  
2,865,362, CANC. INT. CL. 9.
- SAN ANTONIO SHOE, INC., SAN ANTONIO, TX:  
2,426,378, REN. 2-26-11. INT. CL. 25.
- SANAFIR NEW MEDIA & ONLINE AG, 82061 NEURIED BEI MUNCHEN, FED REP GERMANY:  
2,863,990, CANC. MULTIPLE CLASS, INT. CLS. 9, 35 AND 42.
- SANDBERG & SIKORSKI CORPORATION, NEW YORK, NY:  
3,941,298, INT. CL. 14.
- SANDBERG, CHERYL, ROSEVILLE, CA AND SANDBERG, BRUCE, ROSEVILLE, CA:  
3,940,449, PUB. 1-18-2011. INT. CL. 35.
- SANDISK CORPORATION, MILPITAS, CA:  
3,941,114, INT. CL. 9.
- SANDLER, RIC, VENTNOR CITY, NJ:  
2,865,465, CANC. INT. CL. 41.
- SANDRA JORDAN COLLECTION, LLC, THE, HEALDSBURG, CA:  
2,865,767, CANC. INT. CL. 14.
- SANDSTACKERS, INC., STATEN ISLAND, NY:  
2,864,642, CANC. INT. CL. 28.
- SANOFI-AVENTIS, FRANCE:  
3,029,369, COR. INT. CL. 5.
- SANOFI-AVENTIS DEUTSCHLAND GMBH, 65926 FRANKFURT AM MAIN, FED REP GERMANY:  
2,864,805, CANC. INT. CL. 5.
- SANTOS LAGUNA, S.A. DE C.V., TORREON, COAHUILA, C.P. 27000, MEXICO:  
2,864,217, CANC. INT. CL. 16.
- SAPO...X SAS DI CHIARA RONDONI & C., ITALY:  
3,939,953, PUB. 1-18-2011. INT. CL. 25.
- SARDI'S ENTERPRISES LTD., NEW YORK, NY, SARDI'S RESTAURANT SERVICES, INC., NEW YORK, NY:  
1,153,490, REN. 3-1-11. INT. CL. 42.
- SAS LABORATORIES, INC., CHESTNUT HILL, MA:  
2,864,196, CANC. INT. CL. 5.
- SAS MARINATION, 06370 MOUANS SARTOUX, FRANCE:  
2,865,090, CANC. INT. CL. 3.
- SATELLITE LOGISTICS GROUP, INC., HOUSTON, TX:  
3,941,431, MULTIPLE CLASS, INT. CLS. 35, 39 AND 40.  
3,941,432, INT. CL. 35.  
3,941,433, INT. CL. 42.  
3,941,434, INT. CL. 35.
- SAUL SALAMANCA, WINSTON SALEM, NC, DBA PROMESA DISTRIBUTORS:  
3,941,808, INT. CL. 5.
- SAVE-A-LOT FOOD STORES, LTD., EARTH CITY, MO:  
2,865,692, CANC. INT. CL. 30.  
3,941,974, MULTIPLE CLASS, INT. CLS. 29 AND 30.
- SAVEN CORPORATION, CHARLESTON, WV, HUSTON PRODUCE, INC., EAST LANSING, MI:  
1,636,261, REN. 2-25-11. INT. CL. 31.
- SAVING AMERICA'S FOUNDATION, RANCHO SANTE FE, CA:  
3,942,356, MULTIPLE CLASS, INT. CLS. 35, 36 AND 41.
- SAVING PROMISE INC., WASHINGTON, DC:  
3,941,506, INT. CL. 35.
- SAVOX COMMUNICATIONS OY AB (LTD), FINLAND:  
3,939,971, PUB. 1-18-2011. MULTIPLE CLASS, INT. CLS. 9, 35, 36, 37, 38 AND 42.
- SAYEGH, JOSEPH, CORONA DEL MAR, CA:  
3,939,856, PUB. 1-18-2011. INT. CL. 35.
- SBA INTERNATIONAL LLC, AURORA, CO:  
2,864,829, CANC. INT. CL. 43.
- SBIM CONSULTING LLC, COLUMBIA, MD:  
3,941,393, INT. CL. 35.
- SC FM MEDIDENT SRL, BUCURESTI, ROMANIA:  
3,940,036, PUB. 1-18-2011. INT. CL. 44.
- SCAM-CO., LLC, SANTA BARBARA, CA:  
2,865,276, CANC. INT. CL. 25.
- SCAP, FRANCE:  
3,939,997, PUB. 1-18-2011. MULTIPLE CLASS, INT. CLS. 16, 35 AND 41.
- SCAPHELD PRODUCTION, INC., CINCINNATI, OH:  
2,865,182, CANC. INT. CL. 25.
- SCHAEFFER, DON, WAKE FOREST, NC:  
3,940,521, PUB. 1-18-2011. INT. CL. 21.
- SCHAFFNER MANUFACTURING COMPANY, INC., PITTSBURGH, PA:  
2,436,268, REN. 2-26-11. INT. CL. 7.
- SCHERING-PLOUGH HEALTHCARE PRODUCTS, INC., MEMPHIS, TN:  
2,865,573, CANC. INT. CL. 3.
- SCHILLINGER DEVELOPMENT, INC., SCOTTSDALE, AZ:  
2,539,899, REN. 2-26-11. INT. CL. 36.
- SCHOEPP MOTORS, INC., MIDDLETON, WI:  
3,939,575, PUB. 1-18-2011. INT. CL. 35.  
3,939,576, PUB. 1-18-2011. INT. CL. 37.
- SCHOOL APPAREL, INC., BURLINGAME, CA:  
3,941,335, MULTIPLE CLASS, INT. CLS. 25 AND 40.  
3,941,351, MULTIPLE CLASS, INT. CLS. 35 AND 36.  
3,941,352, MULTIPLE CLASS, INT. CLS. 35 AND 36.
- SCHOOLHOUSE CAPITAL, LLC, BOSTON, MA:  
2,865,739, CANC. INT. CL. 36.
- SCHOTT GEMTRON CORPORATION, SWEETWATER, TN:  
3,940,584, PUB. 1-18-2011. INT. CL. 11.
- SCHRADER-BRIDGEPORT INTERNATIONAL, INC., ALTAVISTA, VA:  
3,941,109, MULTIPLE CLASS, INT. CLS. 6, 7, 8, 9 AND 12.
- SCHROEDER INDUSTRIES LLC, BETHLEHEM, PA, SCHROEDER BROTHERS CORPORATION, MCKEES ROCKS, PA:  
921,089, REN. 2-26-11. U.S. CL. 26 (INT. CL. 9).
- SCHULZ FAMILY INTELLECTUALPROPERTY TRUST DTD., SANTA ROSA, CA:  
2,490,527, REN. 3-1-11. INT. CL. 41.
- SCHWAN'S IP, LLC, MARSHALL, MN:  
2,864,798, CANC. MULTIPLE CLASS, INT. CLS. 16, 41 AND 45.

SCHWANK GMBH, FED REP GERMANY:  
3,939,914, PUB. 1-18-2011. MULTIPLE CLASS, INT. CLS. 9 AND 11.

SCHWARTZ, HARRY W., YARMOUTH, ME:  
2,375,605, CANC. INT. CL. 30.

SCIENCEFRIDAY, INC., STAMFORD, CT:  
3,939,858, PUB. 1-18-2011. INT. CL. 41.

SCIENTIFIC AND ENGINEERING SOFTWARE, INC., AUSTIN, TX TO HYPERFORMIX, INC., AUSTIN, TX:  
1,906,361, CANC. INT. CL. 9.

SCM MICROSYSTEMS GMBH, FED REP GERMANY:  
3,939,958, PUB. 1-18-2011. MULTIPLE CLASS, INT. CLS. 9 AND 42.

SCONZA CANDY COMPANY, OAKLAND, CA:  
2,504,966, CANC. INT. CL. 30.

SCOTT ADAMS, INC., DANVILLE, CA:  
2,369,072, CANC. INT. CL. 21.

SCOTT JURK, GEORGETOWN, TX:  
3,942,387, INT. CL. 9.

SCOTT MACHINE DEVELOPMENT CORPORATION, WALTON, NY:  
1,640,229, REN. 2-28-11. INT. CL. 7.

SCOTT PET PRODUCTS, INC., ROCKVILLE, IN:  
3,940,845, PUB. 1-18-2011. INT. CL. 31.

SCOTT STREAM, INC., RENO, NV:  
2,865,130, CANC. INT. CL. 35.

SCOTT, GINI GRAHAM, OAKLAND, CA, DBA CREATIVE COMMUNICATIONS & RESEARCH:  
3,941,081, INT. CL. 41.

SCOTTRADE, INC., ST. LOUIS, MO:  
3,941,794, INT. CL. 36.

SCOVILL CREEK FARM LLC, DALTON CITY, IL:  
3,941,078, INT. CL. 29.

SCRAPBOOK SALLY INC., CALGARY, ALBERTA, CANADA:  
2,864,750, CANC. INT. CL. 16.

SCREENWORKS USA INC., ORLANDO, FL:  
2,865,221, CANC. INT. CL. 25.

SCS COLLECTIBLES, INC., STRATFORD, CT:  
3,940,167, PUB. 1-18-2011. INT. CL. 35.

SCUBA TOOLS, INC., GREENSBORO, NC:  
3,942,350, INT. CL. 9.  
3,942,351, INT. CL. 8.

SDI HEALTH LLC, PLYMOUTH MEETING, PA:  
2,534,290, REN. 2-26-11. INT. CL. 42.

SEA BOX, INC., RIVERTON, NJ:  
3,942,106, INT. CL. 11.

SEA BYTE, INC., BRADENTON, FL:  
2,368,856, CANC. INT. CL. 42.

SEA RESEARCH FOUNDATION, INC., MYSTIC, CT:  
2,430,765, REN. 2-26-11. INT. CL. 41.

SEACOI INVESTMENTS, INC., MIAMI, FL:  
3,940,785, PUB. 1-18-2011. INT. CL. 34.

SEARS BRANDS, LLC, HOFFMAN ESTATES, IL:  
538,081, REN. 2-26-11. U.S. CL. 31 (INT. CLS. 7, 11 AND 12).  
2,368,879, CANC. INT. CL. 11.  
3,942,338, INT. CL. 7.

SEAWEED SYSTEMS, INC., WOODINVILLE, WA:  
2,864,466, CANC. MULTIPLE CLASS, INT. CLS. 9 AND 42.

SECTION EIGHT INC., TORONTO, ONTARIO, CANADA, DBA PANIC & BOB EDITING:  
2,425,193, REN. 2-25-11. INT. CL. 41.

SECURE DOCUMENT SYSTEMS, INC., JACKSONVILLE, FL:  
2,382,127, REN. 2-26-11. MULTIPLE CLASS, INT. CLS. 35 AND 36.

SECURITY SOURCING INTERNATIONAL, INC., LOS ANGELES, CA:  
3,942,306, INT. CL. 25.

SEDO.COM, LLC, CAMBRIDGE, MA:  
3,939,579, PUB. 10-12-2010. INT. CL. 36.

SEER SYSTEMS, INC., PORTOLA VALLEY, CA:  
2,367,353, CANC. INT. CL. 15.

SEFTE LIVING, LLC, SAN FRANCISCO, NJ:  
3,941,307, INT. CL. 24.

SEGO HOMES, LC, LINDON, UT:  
3,942,184, INT. CL. 37.

SEIKO EPSON KABUSHIKI KAISHA, SHINJUKU-KU, TOKYO, JAPAN, DBA SEIKO EPSON CORPORATION:  
2,864,283, CANC. INT. CL. 9.

SELLSTROM MANUFACTURING COMPANY, PALATINE, IL:  
2,431,723, REN. 2-26-11. INT. CL. 9.

SEMICONDUCTOR INDUSTRY ASSOCIATION, WASHINGTON, DC:  
1,632,334, REN. 3-1-11. INT. CL. 16.

SEMTECH CORPORATION, CAMARILLO, CA:  
2,436,706, REN. 2-26-11. INT. CL. 9.

SENIOR STAR MANAGEMENT COMPANY, TULSA, OK:  
3,942,359, MULTIPLE CLASS, INT. CLS. 35, 44 AND 45.

SENSABLE TECHNOLOGIES, INC., WILMINGTON, MA:  
2,430,161, REN. 2-26-11. INT. CL. 9.

SENZ TECHNOLOGIES B.V., NETHERLANDS:  
3,362,637, COR. MULTIPLE CLASS, INT. CLS. 18 AND 22.

SEQUEL NATURALS INC., PORT COQUITLAM, CANADA:  
3,940,705, PUB. 1-18-2011. MULTIPLE CLASS, INT. CLS. 41 AND 44.

SEQUEL NATURALS, INC., BLAINE, WA:  
3,939,840, PUB. 1-18-2011. INT. CL. 29.  
3,939,841, PUB. 1-18-2011. INT. CL. 29.  
3,939,844, PUB. 1-18-2011. MULTIPLE CLASS, INT. CLS. 5 AND 32.

SER-JOBS FOR PROGRESS NATIONAL, INC., IRVING, TX:  
2,063,419, CANC. INT. CL. 16.

SERENIGY GLOBAL, INC., MIAMI, FL:  
3,942,008, MULTIPLE CLASS, INT. CLS. 5 AND 30.

SERONO SYMPOSIA INTERNATIONAL FOUNDATION, ROME, ITALY:  
2,864,768, CANC. MULTIPLE CLASS, INT. CLS. 16, 41 AND 44.

SEROYAL U.S.A., INC., WOOD DALE, IL:  
2,430,878, REN. 2-26-11. MULTIPLE CLASS, INT. CLS. 3 AND 5.

SERVANTHOOD, INC., LAURELTON, NY:  
3,941,289, MULTIPLE CLASS, INT. CLS. 18, 28 AND 32.

SERVICE COMPANY SOLUTIONS, LLC, BEDFORD, NH:  
3,940,690, PUB. 1-18-2011. INT. CL. 9.  
3,942,376, INT. CL. 41.

SERVICEMASTER BRANDS L.L.C., BURLINGTON, VT:  
2,503,865, REN. 3-3-11. INT. CL. 37.

SESAME WORKSHOP, NEW YORK, NY:  
3,942,072, MULTIPLE CLASS, INT. CLS. 16, 25, 28 AND 41.

SEVERSTAL WHEELING, INC., WHEELING, WV:  
2,418,864, REN. 2-25-11. INT. CL. 6.

SF INVESTMENTS, INC., WILMINGTON, DE:  
2,380,824, REN. 2-26-11. INT. CL. 29.  
3,940,186, PUB. 1-18-2011. INT. CL. 43.  
3,940,187, PUB. 1-18-2011. INT. CL. 43.

SF-KOOPERATION GMBH BETON-KONZEPTE, BREMEN, FED REP GERMANY:  
2,864,761, CANC. INT. CL. 19.

SFN PROFESSIONAL SERVICES LLC, FORT LAUDERDALE, FL:  
2,865,806, CANC. INT. CL. 35.

SGS SPORTS INC., MONTREAL, QUEBEC, CANADA:  
3,939,786, PUB. 1-18-2011. INT. CL. 25.

SHAFFER, W. BENJAMIN, GALENA, OH:  
3,941,832, INT. CL. 45.

SHALLENBERGER, FRANK, CARSON CITY, NV:  
2,864,572, CANC. INT. CL. 44.

SHAMROCK FOODS COMPANY, PHOENIX, AZ:  
3,941,596, INT. CL. 29.

SHANDONG JIANGCHEN GARMENT CO.,LTD., ZIBO CITY, SHANDONG, CHINA:  
3,940,605, PUB. 1-18-2011. INT. CL. 25.

SHANTOU VERBINI COSTUME CO., LTD., GUANGDONG PROVINCE, CHINA:  
3,939,919, PUB. 1-18-2011. MULTIPLE CLASS, INT. CLS. 18, 25 AND 26.

SHARKHEADS, INC., BILOXI, MS:  
2,530,589, REN. 2-26-11. INT. CL. 35.

- SHARON LYNN CAMPBELL, LLC, ROCHELLE, VA:  
3,940,747, PUB. 1-18-2011. INT. CL. 25.  
3,940,802, PUB. 1-18-2011. INT. CL. 16.
- SHEETZ OF DELAWARE, INC., WILMINGTON, DE:  
2,368,231, CANC. INT. CL. 35.  
3,941,148, MULTIPLE CLASS, INT. CLS. 29 AND 30.
- SHELL TRADEMARK MANAGEMENT BV, THE HAGUE, NETHERLANDS:  
3,941,292, INT. CL. 35.  
3,941,295, INT. CL. 35.
- SHELTERLOGIC LLC, WATERTOWN, CT:  
2,925,005, CANC. INT. CL. 19.
- SHENANDOAH VINEYARDS, PLYMOUTH, CA:  
2,576,226, CANC. INT. CL. 33.
- SHEREE BREKKE, SAN LUIS OBISPO, CA AND TOBIAS S. BREKKE, SAN LUIS OBISPO, CA:  
3,942,240, INT. CL. 30.  
3,942,241, INT. CL. 30.
- SHI SYMBOL INTERNATIONAL PTY LTD, EAST PERTH, AUSTRALIA:  
3,939,417, PUB. 1-18-2011. MULTIPLE CLASS, INT. CLS. 14 AND 45.
- SHIELD INDUSTRIES, INC., WOODSTOCK, GA:  
2,865,325, CANC. INT. CL. 1.
- SHIELDS, ARMAN, ADELPHI, MD:  
3,941,526, INT. CL. 25.
- SHIH, JARED J, NEW YORK, NY:  
3,940,815, PUB. 1-18-2011. INT. CL. 25.
- SHIMADZU CORPORATION, KYOTO, JAPAN:  
3,940,086, PUB. 1-18-2011. INT. CL. 9.
- SHIMANO INC., SAKAI OSAKA 590-8577, JAPAN:  
2,368,455, CANC. INT. CL. 12.
- SHIN, DONG CHEOL, VERNON, CA:  
2,865,095, CANC. INT. CL. 20.
- SHINE INTERNATIONAL CORP., HOMOSASSA, FL:  
2,864,566, CANC. INT. CL. 10.
- SHINHAN BANK CORPORATION, SEOUL, REPUBLIC OF KOREA:  
2,443,874, REN. 2-26-11. INT. CL. 36.
- SHIPP, KEVIN MICHAEL, WARRENTON, VA:  
2,865,649, CANC. INT. CL. 41.
- SHMIRSHKY UNIVERSAL, LLC, CORONADO, CA:  
3,941,363, INT. CL. 16.
- SHOEI CO., LTD., TOKYO, JAPAN:  
3,941,785, INT. CL. 9.
- SHOP COLETTE LTD., CHICAGO, IL:  
3,940,675, PUB. 1-18-2011. INT. CL. 3.
- SHOPFORBAGS, INC., DALLAS, TX:  
3,939,514, PUB. 1-18-2011. MULTIPLE CLASS, INT. CLS. 18, 25 AND 35.  
3,939,548, PUB. 1-18-2011. MULTIPLE CLASS, INT. CLS. 18 AND 25.
- SHOULDERS, KATHERINE, FAYETTEVILLE, AR:  
2,864,664, CANC. INT. CL. 41.
- SHOW FEEDS, INC., SHELBY, OH:  
2,865,075, CANC. INT. CL. 5.
- SHOWA GLOVE CO., HIMEJI HYOGO, JAPAN:  
2,517,439, REN. 2-26-11. INT. CL. 9.  
2,517,440, REN. 2-26-11. INT. CL. 9.  
2,522,640, REN. 2-26-11. INT. CL. 9.
- SHOWTIME NETWORKS INC, NEW YORK, NY:  
3,941,751, INT. CL. 25.
- SHOWTIME NETWORKS INC., NEW YORK, NY:  
3,941,867, INT. CL. 41.
- SHRINKIT INC., LINDEN, NJ:  
2,368,723, CANC. INT. CL. 16.  
2,368,724, CANC. INT. CL. 16.
- SHUBERT, ERIC, PALO ALTO, CA, DBA ZOO WIRELESS:  
2,865,634, CANC. INT. CL. 42.
- SHUFFLE MASTER, INC., LAS VEGAS, NV:  
2,458,905, REN. 2-26-11. INT. CL. 28.  
3,940,931, PUB. 1-18-2011. INT. CL. 41.  
3,941,563, INT. CL. 9.
- SHULMAN, JACK A., WESTFIELD, NJ:  
2,718,463, CANC. INT. CL. 35.
- SICARI, VINCENZO A., UPPER SADDLE RIVER, NJ:  
2,865,674, CANC. INT. CL. 25.  
2,865,675, CANC. INT. CL. 21.
- SICURANZA, JOSEPH, EASTCHESTER, NY:  
3,941,858, INT. CL. 37.
- SIDE BY SIDE, INC., AUSTIN, TX:  
2,368,708, CANC. INT. CL. 16.  
2,368,710, CANC. INT. CL. 16.
- SIEGFRIED RITTER, FED REP GERMANY:  
3,939,880, PUB. 1-19-2010. INT. CL. 9.
- SIEMENS AKTIENGESELLSCHAFT, MUNICH, FED REP GERMANY:  
2,437,998, REN. 3-1-11. INT. CL. 9.  
2,863,889, CANC. INT. CL. 9.
- SIEMENS HEALTHCARE DIAGNOSTICS INC., DEERFIELD, IL:  
2,427,460, REN. 2-26-11. MULTIPLE CLASS, INT. CLS. 5 AND 10.
- SIEMENS WATER TECHNOLOGIES HOLDING CORP., WARRENDALE, PA:  
2,430,403, REN. 2-26-11. INT. CL. 11.
- SIENKIEWICZ, ELEANOR (ELLY), WASHINGTON, DC:  
2,442,825, REN. 3-3-11. INT. CL. 41.
- SIENKIEWICZ, ELEANOR PATTON HAMILTON, WASHINGTON, DC:  
2,512,038, REN. 3-2-11. INT. CL. 41.
- SIERRA HEALTHSTYLES LLC, TUCSON, AZ:  
3,942,012, INT. CL. 44.
- SIERRAPINE, ROSEVILLE, CA:  
2,432,845, REN. 2-26-11. INT. CL. 19.
- SIF PRODUCTS GROUP INC., NIWOT, CO:  
2,432,214, REN. 2-26-11. INT. CL. 20.
- SIG FINANZ AG (SIG FINANCE LTD.), RHEINFALL, SWITZERLAND:  
1,149,605, REN. 3-3-11. INT. CL. 7.  
1,149,605, CANC. INT. CL. 12.
- SIGHT'S MY LINE, INC., MCALLEN, TX, DBA EYEAR OPTICAL:  
3,374,752, CANC. INT. CL. 41.
- SIGNALSET, INC., SALT LAKE CITY, UT:  
3,939,861, PUB. 1-18-2011. INT. CL. 35.
- SIGNATURE REAL ESTATE, LLC, MOBILE, AL:  
3,939,690, PUB. 1-18-2011. INT. CL. 36.
- SIKA AG, SWITZERLAND:  
3,940,038, PUB. 1-18-2011. MULTIPLE CLASS, INT. CLS. 1, 2, 17, 19 AND 27.
- SILICON FIRE AG, SWITZERLAND:  
3,939,933, PUB. 1-18-2011. MULTIPLE CLASS, INT. CLS. 1, 4, 7, 9 AND 12.
- SILICON IMAGE, INC., SUNNYVALE, CA:  
3,942,066, MULTIPLE CLASS, INT. CLS. 9 AND 42.
- SILVANDERSSON SWEDEN AKTIEBOLAG, S-310 20 KNARED, SWEDEN:  
2,723,239, CANC. MULTIPLE CLASS, INT. CLS. 5, 9 AND 21.
- SILVER DOLLAR OPTICAL CORPORATION, ONEONTA, NY:  
3,940,921, PUB. 1-18-2011. INT. CL. 35.
- SILVER GOOSE, INC., NEW YORK, NY:  
2,367,586, CANC. INT. CL. 25.
- SILVERADO VINEYARDS, THE, NAPA, CA:  
2,428,632, REN. 3-2-11. INT. CL. 33.  
2,525,224, REN. 3-2-11. INT. CL. 33.
- SIMMONS, WILLIAM T., WOODBURY HEIGHTS, NJ:  
2,436,305, REN. 2-25-11. INT. CL. 41.
- SIMON & SCHUSTER, INC., NEW YORK, NY:  
2,864,563, CANC. INT. CL. 16.
- SIMON PAUL SCOTT, INC., LOS ANGELES, CA, DBA JARDINS EN FLEUR:  
3,940,287, PUB. 1-18-2011. INT. CL. 27.
- SIMON, SAUL M., EDISON, NJ:  
2,440,579, REN. 2-28-11. INT. CL. 36.  
2,440,582, REN. 2-28-11. INT. CL. 16.
- SIMONTON BUILDING PRODUCTS, INC., PARKERSBURG, WV:  
2,432,198, REN. 3-3-11. INT. CL. 19.
- SIMPLE ABUNDANCE, INC., BALTIMORE, MD:  
2,367,856, CANC. MULTIPLE CLASS, INT. CLS. 9 AND 16.
- SIMR, INC., SAN DIEGO, CA:  
3,940,858, PUB. 1-18-2011. INT. CL. 28.



SINCLAIR FINANCE COMPANY, SALT LAKE CITY, UT:  
2,865,450, CANC. INT. CL. 25.

SINDELAR, JAMES C., HOPKINTON, NH:  
3,941,712, INT. CL. 8.

SINGAPORE AIRLINES CARGO PTE LTD, SINGAPORE:  
2,864,420, CANC. INT. CL. 39.

SINGLETON FISHERIES, INC., VERNON, CA:  
2,864,489, CANC. INT. CL. 29.

SIOS TECHNOLOGY, INC., MINATO-KU, TOKYO, JAPAN:  
3,939,391, PUB. 11-27-2007. INT. CL. 9.  
3,940,975, PUB. 11-9-2010. INT. CL. 42.

SIP RIGHTS LLC, BECA RATON, FL:  
2,367,897, CANC. INT. CL. 35.

SIREN INTERACTIVE CORPORATION, OAK PARK, IL:  
2,504,138, REN. 3-2-11. INT. CL. 42.  
2,504,140, REN. 3-2-11. INT. CL. 42.

SISCO TEXTILES N.V., CURAÇAO, NETHERLANDS:  
3,939,936, PUB. 1-18-2011. MULTIPLE CLASS, INT. CLS.  
3, 9, 14, 16, 18, 25, 28 AND 35.

SISTER SCHUBERT'S HOMEMADE ROLLS, INC., LU-  
VERNE, AL:  
2,438,329, REN. 3-3-11. INT. CL. 30.

SITETEL SWEDEN AB, SWEDEN:  
3,939,912, PUB. 1-18-2011. MULTIPLE CLASS, INT. CLS.  
7, 9, 11, 38, 39 AND 40.

SJOSTROM, ROLF, VIKTOR, N-5143 FYLLINGSDALEN,  
NORWAY:  
2,865,068, CANC. INT. CL. 21.

SK TREE CORPORATION, SANTA MONICA, CA:  
3,941,553, INT. CL. 30.

SKA! DESIGN, INC., DALLAS, TX:  
2,146,341, CANC. INT. CL. 25.

SKINDER-STRAUSS ASSOCIATES, NEWARK, NJ, SKIN-  
DER-STRAUSS CORP., NEWARK, NJ, AKA NEW JERSEY  
LAW JOURNAL PUBLISHING CO.:  
1,182,040, REN. 3-3-11. INT. CL. 16.

SKINIT, INC., SAN DIEGO, CA:  
3,941,686, MULTIPLE CLASS, INT. CLS. 9 AND 40.

SKINN COSMETICS, LLC, TORRANCE, CA:  
3,941,834, INT. CL. 3.

SKINVESTMENT, LLC, WASHINGTON, DC:  
2,865,483, CANC. INT. CL. 10.

SKIPOLINI'S INC., WALNUT CREEK, CA:  
3,940,620, PUB. 1-18-2011. MULTIPLE CLASS, INT. CLS.  
25, 39 AND 43.  
3,940,621, PUB. 1-18-2011. MULTIPLE CLASS, INT. CLS.  
25, 39 AND 43.

SKONBERG, CAROLYN H., HOUSTON, TX:  
2,865,564, CANC. INT. CL. 14.

SKYLINE EQUITIES REALTY, LLC, MIAMI, FL:  
3,940,533, PUB. 1-18-2011. INT. CL. 37.

SKYLINE TENT COMPANY, CHARLOTTESVILLE, VA:  
3,940,391, PUB. 1-18-2011. INT. CL. 43.

SKYLOTEC GMBH, FED REP GERMANY:  
3,940,033, PUB. 1-18-2011. MULTIPLE CLASS, INT. CLS.  
5, 9, 10, 18, 22, 25, 28 AND 37.

SLIC TRADING COMPANY LIMITED, BELIZE CITY, BE-  
LIZE:  
3,940,387, PUB. 1-18-2011. INT. CL. 7.

SLIPP-NOTT CORPORATION, LAS CRUCES, NM:  
2,367,644, CANC. INT. CL. 27.

SLO VENTURES INC., SAN LUIS OBISPO, CA:  
2,368,755, CANC. INT. CL. 14.

SMALL BOX CONSULTING, INC., INDIANAPOLIS, IN:  
3,940,390, PUB. 1-18-2011. MULTIPLE CLASS, INT. CLS.  
35 AND 42.

SMALL BUSINESS TIMES, LLC, MILWAUKEE, WI:  
2,368,720, CANC. INT. CL. 16.

SMALLS & SMALLS MOVERS LLC, ROCKVILLE, MD:  
3,940,760, PUB. 1-18-2011. INT. CL. 39.

SMALLS, WAYNE PRESTON, WASHINGTON, DC:  
2,367,314, CANC. INT. CL. 9.

SMART CITY HOLDINGS, L.L.C., LAKE BUENA VISTA, FL:  
3,939,350, PUB. 1-18-2011. MULTIPLE CLASS, INT. CLS.  
37, 38 AND 42.

SMART CRUISER. COM LLC, BOCA RATON, FL:  
2,431,169, REN. 2-26-11. MULTIPLE CLASS, INT. CLS. 39  
AND 42.

SMART PARTS, INC., LOYALHANNA, PA:  
2,864,608, CANC. INT. CL. 25.

SMART TECHNOLOGIES ULC, CALGARY, ALBERTA,  
CANADA:  
3,942,401, INT. CL. 9.

SMARTERGO, INC., MORRIS PLAINS, NJ:  
3,941,112, INT. CL. 9.

SMARTHEALTH, INC., PHOENIX, AZ:  
3,941,611, INT. CL. 16.

SMARTWAVE CONSULTING, LLC, MILWAUKEE, WI,  
AKA SMARTWAVE:  
3,940,322, PUB. 1-18-2011. INT. CL. 35.

SMEAD MANUFACTURING COMPANY, THE, HASTINGS,  
MN:  
3,941,465, INT. CL. 16.

SMITH & DUGGAN LLP, BOSTON, MA:  
2,864,628, CANC. INT. CL. 42.

SMITH CUSTOM BUILDERS, INC., HOUSTON, TX:  
2,368,088, CANC. INT. CL. 37.

SMITH INTERNATIONAL, INC., HOUSTON, TX:  
3,941,734, INT. CL. 7.

SMITH MOUNTAIN INDUSTRIES, INC., FOREST, VA:  
3,941,721, INT. CL. 4.

SMITH, CHERYL, PEORIA, AZ:  
2,369,571, CANC. INT. CL. 36.

SMITH, DAVID MICHAEL, APOPKA FL, 32704, FL, DBA  
WORLD GOSPEL INC.:  
3,939,611, PUB. 1-18-2011. INT. CL. 42.

SMITH, LAURIE D., CEDAR CITY, UT, DBA ACTION  
OFFROAD:  
2,865,681, CANC. INT. CL. 35.

SMITH, PATRICIA, VIENNA, VA:  
2,865,518, CANC. INT. CL. 9.

SMITH, R. LELAND B., JR., CITY OF COMMERCE, CA AND  
MURPHY, ERIN L., CITY OF INDUSTRY, CA:  
3,939,784, PUB. 1-18-2011. INT. CL. 25.

SMITHS MEDICAL ASD, INC., KEENE, NH:  
3,941,015, INT. CL. 10.

SMITTY'S SUPPLY, INC., ROSELAND, LA:  
2,424,560, REN. 2-28-11. INT. CL. 3.

SMOOKZZ LICENCE B.V., NETHERLANDS:  
3,939,969, PUB. 1-18-2011. MULTIPLE CLASS, INT. CLS. 9  
AND 34.

SMOOT BROTHERS IP HOLDING COMPANY, PROVO, UT:  
3,940,796, PUB. 1-18-2011. INT. CL. 20.

SMOVEY GMBH, AUSTRIA:  
3,916,132, COR. MULTIPLE CLASS, INT. CLS. 16, 17, 25,  
28, 32, 35, 39, 41 AND 45.

SMW-AUTOBLOK SPANNSYSTEME GMBH, FED REP  
GERMANY:  
3,939,929, PUB. 1-18-2011. INT. CL. 7.

SNAG, INC., TALLEQUAH, OK:  
3,939,700, PUB. 1-18-2011. INT. CL. 28.

SNAPPLE BEVERAGE CORP., RYE BROOK, NY:  
2,865,252, CANC. INT. CL. 32.

SOAKED UP, INC., NEW YORK, NY:  
3,942,220, INT. CL. 5.

SOARING SOFTWARE SOLUTIONS, INC., SWANTON, OH:  
2,865,238, CANC. INT. CL. 9.

SOCCER EXPRESS USA, INC., ST. PAUL, MN:  
2,864,423, CANC. INT. CL. 35.

SOCIAL GAMING NETWORK, INC., PALO ALTO, CA:  
3,941,660, MULTIPLE CLASS, INT. CLS. 9 AND 41.

SOCIAL SMOKE, INC., ARLINGTON, TX:  
3,939,660, PUB. 1-18-2011. INT. CL. 34.

SOCIEDADE DOS VINHOS BORGES, S.A., RIO TINTO,  
PORTUGAL:  
3,940,127, PUB. 1-18-2011. INT. CL. 33.

SOCIEDADE NACIONAL DE COMBUSTIVEIS DE ANGOLA  
SONANGOL EP, LUANDA, ANGOLA:  
3,940,942, PUB. 1-18-2011. INT. CL. 39.

SOCIETE BIC, CLICHY, FRANCE:  
3,941,438, INT. CL. 16.

SOCIETE DES PRODUITS NESTLE S.A., VEVEY, SWITZER-  
LAND:  
1,650,293, REN. 2-26-11. INT. CL. 31.  
2,864,892, CANC. INT. CL. 35.

- SOCIETE DES PRODUITS NESTLE S.A., 1800 VEVEY, SWITZERLAND:  
3,939,426, PUB. 1-18-2011. MULTIPLE CLASS, INT. CLS. 32, 39, 41, 43 AND 44.
- SOCIETES DES PRODUITS NESTLE S.A., VEVEY 1800, SWITZERLAND:  
2,448,440. REN. 2-26-11. INT. CL. 21.
- SOCIETY OF AMERICAN GASTROINTESTINAL AND ENDOSCOPIC SURGEONS (SAGES), LOS ANGELES, CA:  
3,939,739, PUB. 1-18-2011. INT. CL. 41.
- SOCIETY OF CRITICAL CARE MEDICINE, MOUNT PROSPECT, IL:  
2,486,984. REN. 3-1-11. MULTIPLE CLASS, INT. CLS. 9 AND 16.
- SOCIETY OF GOVERNMENT TRAVEL PROFESSIONALS, INC., BETHESDA, MD:  
2,368,913, CANC. INT. CL. 42.
- SOCIO X INC., NEW YORK, NY:  
3,941,884, INT. CL. 31.
- SOCKEYE CONSTRUCTION CORP., AUBURN, WA, DBA SOCKEYE HOMES:  
3,942,422, INT. CL. 37.
- SOFA MART, LLC, DENVER, CO:  
2,507,915. REN. 2-25-11. INT. CL. 35.
- SOFGEN HOLDINGS LIMITED, CYPRUS:  
3,939,951, PUB. 1-18-2011. INT. CL. 42.
- SOFT COMPUTER CONSULTANTS, INC., CLEARWATER, FL:  
3,939,389, PUB. 1-18-2011. INT. CL. 9.
- SOIL SAFE, INC., BALTIMORE, MD:  
2,865,248, CANC. INT. CL. 40.
- SOL ROSA LLC, BENZONIA, MI:  
3,942,226, INT. CL. 3.
- SOLAZYME, INC., SOUTH SAN FRANCISCO, CA:  
3,942,029, MULTIPLE CLASS, INT. CLS. 1, 5 AND 42.
- SOLOMON, RENE P., NEW YORK, NY:  
3,939,496, PUB. 1-18-2011. INT. CL. 41.
- SOLTA MEDICAL, INC., HAYWARD, CA:  
3,941,984, INT. CL. 44.
- SONAFI S.A., VIROFLAY, FRANCE:  
2,865,023, CANC. INT. CL. 30.
- SONIC INNOVATIONS, INC., SALT LAKE CITY, UT:  
2,446,742. REN. 2-25-11. MULTIPLE CLASS, INT. CLS. 9 AND 10.
- SONIC SOLUTIONS, NOVATO, CA:  
2,864,958, CANC. INT. CL. 9.
- SONOGRIP CANADA (2000) INC., SAINTE-FOY (QUEBEC), CANADA:  
2,863,964, CANC. INT. CL. 1.
- SONOVA HOLDING AG, STAEFA, SWITZERLAND:  
2,864,493, CANC. MULTIPLE CLASS, INT. CLS. 9 AND 10.
- SONY COMPUTER ENTERTAINMENT AMERICA LLC, FOSTER CITY, CA:  
3,941,339, MULTIPLE CLASS, INT. CLS. 9 AND 41.
- SONY CORPORATION, TOKYO, JAPAN:  
2,419,796. REN. 2-26-11. INT. CL. 9.  
2,431,928. REN. 2-26-11. INT. CL. 9.  
3,941,188, INT. CL. 9.
- SOVOX INC., SAN DIEGO, CA:  
3,941,852, INT. CL. 35.
- SOREMARTEC S.A., 6700 SCHOPPACH-ARLON, BELGIUM:  
2,865,328, CANC. INT. CL. 30.
- SOREMARTEC SA, BELGIUM:  
3,940,010, PUB. 1-18-2011. MULTIPLE CLASS, INT. CLS. 29 AND 30.
- SORIN GROUP ITALIA S.R.L., ITALY:  
3,940,007, PUB. 1-18-2011. INT. CL. 10.
- SOS NOVELTIES, INC., PASADENA, CA:  
3,941,481, INT. CL. 10.
- SOUL OF AFRICA, DURBIN, SOUTH AFRICA:  
3,939,872, PUB. 1-18-2011. INT. CL. 16.  
3,939,873, PUB. 1-18-2011. INT. CL. 25.
- SOUNDEARTH STRATEGIES, INC., SEATTLE, WA:  
3,939,810, PUB. 1-18-2011. MULTIPLE CLASS, INT. CLS. 37, 40, 42 AND 45.
- SOURCE INTERLINK MAGAZINES, LLC, EL SEGUNDO, CA:  
3,941,340, INT. CL. 16.
- SOUTH BEACH BEVERAGE COMPANY, INC., NORWALK, CT:  
2,864,721, CANC. INT. CL. 35.
- SOUTH DAKOTA STATE UNIVERSITY, BROOKINGS, SD:  
3,939,804, PUB. 1-18-2011. INT. CL. 41.
- SOUTH JERSEY INDUSTRIES, FOLSOM, NJ:  
2,441,039. REN. 2-26-11. INT. CL. 39.  
2,441,048. REN. 3-3-11. INT. CL. 39.
- SOUTH WIND, INC., SILER CITY, NC:  
2,429,475. REN. 2-28-11. MULTIPLE CLASS, INT. CLS. 16 AND 41.  
2,429,476. REN. 2-28-11. MULTIPLE CLASS, INT. CLS. 16 AND 41.
- SOUTHCORP BRANDS PTY LIMITED, SOUTHBANK, VICTORIA, AUSTRALIA:  
2,864,852, CANC. INT. CL. 33.
- SOUTHERN BELLE ORIGINALS, INC., CALHOUN CITY, MS:  
3,939,843, PUB. 1-18-2011. INT. CL. 25.
- SOUTHERN SHOWS, INC., CHARLOTTE, NC:  
909,332. REN. 2-26-11. U.S. CL. 101 (INT. CL. 35).
- SOUTHWORTH, BRUCE, SAN BERNARDINO, CA AND GIBSON, DANNY, SAN BERNARDINO, CA:  
2,865,426, CANC. INT. CL. 25.
- SOVEREIGN CHEMICAL COMPANY, INC., AKRON, OH:  
2,864,037, CANC. INT. CL. 1.
- SOVMESTNOE PREDPRIYATIE ZAKRYTOE AKTSIONERNOE OBCHTCHESTVO "MILAVITSA", BY-220053 MINSK, BELARUS:  
3,916,311, COR. MULTIPLE CLASS, INT. CLS. 10, 25 AND 35.
- SP INDUSTRIES, INC., WARMINSTER, PA:  
2,505,955. REN. 2-25-11. INT. CL. 11.
- SPA LOGIC INC., THORSBY, ALBERTA, CANADA:  
3,940,315, PUB. 1-18-2011. INT. CL. 10.
- SPA PACE LLC, JACKSONVILLE, NC:  
3,940,505, PUB. 1-18-2011. INT. CL. 44.
- SPACE CITY FILMS, HOUSTON, TX:  
3,940,237, PUB. 1-18-2011. INT. CL. 41.
- SPANATIX, INC., SAN FRANCISCO, CA:  
3,940,830, PUB. 1-18-2011. INT. CL. 45.  
3,940,831, PUB. 1-18-2011. INT. CL. 45.
- SPANG COMPANY, PITTSBURGH, PA, MAGNETICS, INC., EAST BUTLER, PA:  
710,186. REN. 3-3-11. U.S. CL. 21 (INT. CL. 9).
- SPANISH BROADCASTING SYSTEM, INC., COCONUT GROVE, FL:  
2,865,576, CANC. MULTIPLE CLASS, INT. CLS. 35, 38 AND 41.
- SPATIAL TECHNOLOGIES INDUSTRY ASSOCIATION, WASHINGTON, DC:  
2,864,542, CANC. MULTIPLE CLASS, INT. CLS. 35 AND 41.
- SPAUN ELECTRONIC GMBH & CO. KG, SINGEN, FED REP GERMANY:  
2,864,821, CANC. MULTIPLE CLASS, INT. CLS. 9, 37 AND 42.
- SPC RESOURCES, INC., HARTSVILLE, SC:  
2,864,971, CANC. MULTIPLE CLASS, INT. CLS. 20, 21 AND 40.
- SPECIALTY FABRICATION, LLC, PALOS VERDES PENINSULA, CA:  
3,941,854, INT. CL. 11.
- SPECIFIED TECHNOLOGIES INC., SOMERVILLE, NJ:  
2,518,017. REN. 3-2-11. INT. CL. 41.
- SPECTRA PREMIUM INDUSTRIES INC., BOUCHERVILLE, CANADA:  
2,865,499, CANC. MULTIPLE CLASS, INT. CLS. 7 AND 11.
- SPECTRUM HEALTH SYSTEM, GRAND RAPIDS, MI:  
3,940,709, PUB. 1-18-2011. INT. CL. 44.
- SPECTRUM INTERNATIONAL CORPORATION, SOUTHLAKE, TX:  
2,368,450, CANC. INT. CL. 8.

SPECTRUM TRACKING SERVICES, INC., CARROLLTON, TX:  
2,865,444, CANC. INT. CL. 37.

SPEEDBALL ART PRODUCTS CO., LLC, STATESVILLE, NC:  
1,635,469, REN. 2-25-11. INT. CL. 16.

SPEERINGS CORPORATION, BIRMINGHAM, MI:  
2,369,158, CANC. INT. CL. 42.

SPELLBINDERS PAPER ARTS COMPANY, LLC, PEORIA, AZ:  
3,151,646, CANC. INT. CL. 8.

SPELLBINDERS PAPER CRAFTS, INC., OAKWOOD VILLAGE, OH:  
3,142,994, CANC. INT. CL. 16.

SPELLING TELEVISION INC., STUDIOS CITY, CA:  
2,481,263, CANC. INT. CL. 41.

SPELLMAN, ORION, PACIFIC GROVE, CA:  
3,940,881, PUB. 1-18-2011. INT. CL. 25.

SPELMAN COLLEGE, ATLANTA, GA:  
1,636,931, REN. 2-25-11. INT. CL. 20.  
1,639,165, REN. 3-1-11. INT. CL. 25.

SPI INTERNATIONAL B.V., NETHERLANDS:  
3,940,067, PUB. 1-18-2011. INT. CL. 38.  
3,940,068, PUB. 1-18-2011. INT. CL. 38.

SPIER WINES (PTY) LTD., STELLENBOSCH, SOUTH AFRICA:  
2,864,123, CANC. INT. CL. 33.

SPILL 911, INC., WESTFIELD, IN:  
2,864,170, CANC. INT. CL. 3.

SPINA, BRIEN S., MARCO ISLAND, FL, DBA OFF THE HOOK COMEDY CLUB:  
3,940,207, PUB. 1-18-2011. INT. CL. 41.

SPINK AND SON LIMITED, LONDON, ENGLAND:  
2,429,066, REN. 2-26-11. INT. CL. 14.

SPIRIT ARTIST, LLC, FOGELSVILLE, PA:  
3,940,405, PUB. 1-18-2011. INT. CL. 14.

SPIRIT HOODS LLC, PORTLAND, OR:  
3,939,759, PUB. 1-18-2011. INT. CL. 25.

SPIRIT MANUFACTURING, INC., JONESBORO, AR:  
3,940,519, PUB. 1-18-2011. INT. CL. 28.

SPONG, DOUGLAS BENSON, ISLE OF CAPRI, QUEENSLAND, AUSTRALIA:  
2,864,077, CANC. MULTIPLE CLASS, INT. CLS. 9 AND 25.

SPONTANEOUS GAMES, INC., BILLINGS, MT:  
3,941,813, INT. CL. 28.

SPORTSBLOGS, INC., WASHINGTON, DC, DBA SB NATION:  
3,940,855, PUB. 1-18-2011. INT. CL. 41.

SPORTSENSE, LLC., NORWICH, CT:  
3,941,419, INT. CL. 28.

SPOT INC., ONTARIO, CANADA:  
2,864,059, CANC. INT. CL. 8.

SPOT411 TECHNOLOGIES, INC., ORANGE, CA:  
3,941,382, INT. CL. 41.

SPRINGFIELD SIGN AND GRAPHICS, INC., SPRINGFIELD, MO:  
3,941,336, MULTIPLE CLASS, INT. CLS. 6, 9 AND 19.  
3,941,337, MULTIPLE CLASS, INT. CLS. 6, 9 AND 19.

SPRINGFIELD, DEBRA L., COLLIERVILLE, TN:  
2,865,141, CANC. INT. CL. 16.  
2,865,142, CANC. INT. CL. 16.

SPRINGFIELD, INC., GENESEO, IL:  
3,942,063, INT. CL. 13.

SPRINT COMMUNICATIONS COMPANY L.P., OVERLAND PARK, KS:  
2,864,521, CANC. INT. CL. 9.

SPS TECHNOLOGIES, LLC, JENKINTOWN, PA:  
2,369,233, CANC. INT. CL. 6.

SQAD INC., TARRYTOWN, NY:  
2,428,589, REN. 2-28-11. INT. CL. 9.

SQUIRREL BRAND, L.P., MCKINNEY, TX:  
3,942,385, INT. CL. 29.

SQUIRREL SYSTEMS, G.P., BURNABY, BC, CANADA:  
3,939,584, PUB. 1-18-2011. MULTIPLE CLASS, INT. CLS. 35, 41 AND 42.

SRI INTERNATIONAL, MENLO PARK, CA:  
2,471,649, REN. 3-2-11. INT. CL. 9.  
2,471,746, REN. 3-2-11. INT. CL. 9.

SRI SPORTS KABUSHIKI KAISHA, KOBE-SHI, HYOGO, JAPAN, TA SRI SPORTS LIMITED:  
3,942,090, INT. CL. 28.

SRI USA, INC., AMHERST, NY:  
2,865,706, CANC. INT. CL. 12.

SRS LABS, INC., SANTA ANA, CA:  
2,446,751, REN. 2-25-11. INT. CL. 9.

SSB DESIGN, INC, SANTA ANA, CA, DBA CYGOLITE:  
3,940,358, PUB. 1-18-2011. INT. CL. 11.

SSG CAPITAL ADVISORS, LLC, WEST CONSHOHOCKEN, PA:  
3,939,672, PUB. 1-18-2011. INT. CL. 36.

ST. JOHN, NOAH J., NORTON, OH:  
2,865,104, CANC. INT. CL. 9.

ST. JOHN'S MEDICAL RESEARCH INSTITUTE, INC., SPRINGFIELD, MO:  
3,941,316, INT. CL. 40.

ST. LAWRENCE TEXTILES INC., MONTREAL, QUEBEC, CANADA:  
1,611,246, REN. 3-2-11. INT. CL. 25.

STADT HOLDINGS CORPORATION, BROOKLYN, NY:  
2,536,696, REN. 2-26-11. INT. CL. 30.

STAFF AND LINE, FRANCE:  
3,939,920, PUB. 1-18-2011. MULTIPLE CLASS, INT. CLS. 9, 35, 38 AND 42.  
3,939,921, PUB. 1-18-2011. MULTIPLE CLASS, INT. CLS. 9, 35, 38 AND 42.

STAG CAPITAL PARTNERS, LLC, BOSTON, MA:  
3,940,903, PUB. 1-18-2011. INT. CL. 36.

STAMPED FITTINGS, INC., ELMIRA, NY:  
3,939,833, PUB. 1-18-2011. INT. CL. 6.

STANDARD MORTGAGE CORPORATION, NEW ORLEANS, LA:  
2,367,324, CANC. INT. CL. 36.

STANDARD NINE INC., SAN FRANCISCO, CA, DBA INKLING:  
3,940,201, PUB. 1-18-2011. MULTIPLE CLASS, INT. CLS. 9 AND 42.  
3,940,202, PUB. 1-18-2011. MULTIPLE CLASS, INT. CLS. 9 AND 42.

STANDARD TEXTILE CO. INC., CINCINNATI, OH:  
1,661,596, REN. 2-26-11. INT. CL. 10.

STANLEY LOGISTICS, INC., NEW BRITAIN, CT:  
909,538, REN. 3-3-11. U.S. CL. 23 (INT. CL. 8).

STANTON CARPET CORP., SYOSSET, NY:  
2,481,873, REN. 2-25-11. INT. CL. 27.

STAPLES THE OFFICE SUPERSTORE, LLC, FRAMINGHAM, MA:  
2,504,479, REN. 3-2-11. MULTIPLE CLASS, INT. CLS. 21, 25, 35 AND 41.

STAPLES, LEXI, TOLEDO, OH:  
3,942,423, INT. CL. 41.

STAR PACKAGING CORP., COLLEGE PARK, GA:  
1,150,813, REN. 3-2-11. INT. CL. 7.

STAR SHUTTLE, INC., SAN ANTONIO, TX:  
2,387,748, CANC. INT. CL. 39.

STARBOARD CRUISE SERVICES, INC., MIAMI, FL:  
2,368,560, CANC. INT. CL. 3.

STARBUCKS CORPORATION, SEATTLE, WA, DBA STARBUCKS COFFEE COMPANY:  
3,939,715, PUB. 1-18-2011. MULTIPLE CLASS, INT. CLS. 29, 30 AND 32.

STARCREST PRODUCTS OF CALIFORNIA, INC., PERRIS, CA:  
1,672,180, REN. 2-26-11. INT. CL. 42.

STARGATE ACQUISITION CORP., NEW YORK, NY:  
2,865,708, CANC. INT. CL. 36.  
2,865,709, CANC. INT. CL. 36.

STARLIGHT CHILDREN'S FOUNDATION AUSTRALIA, ST. LEONARDS, NSW, AUSTRALIA:  
3,939,494, PUB. 1-18-2011. MULTIPLE CLASS, INT. CLS. 38 AND 41.

STARTOUT, NEW YORK, NY:  
3,940,355, PUB. 1-18-2011. MULTIPLE CLASS, INT. CLS. 35 AND 41.

- STARZ ENTERTAINMENT, LLC, ENGLEWOOD, CO:  
3,941,910, MULTIPLE CLASS, INT. CLS. 9, 38 AND 41.
- STATE INDUSTRIAL PRODUCTS, CLEVELAND, OH:  
2,517,945, CANC. INT. CL. 7.
- STATESERV MEDICAL, LLC, TEMPE, AZ:  
3,940,277, PUB. 1-18-2011. INT. CL. 35.
- STATS CHIPPAC, INC., FREMONT, CA:  
2,863,927, CANC. MULTIPLE CLASS, INT. CLS. 40 AND 42.
- STAVIS SEAFOODS, INC., BOSTON, MA:  
3,942,104, INT. CL. 29.
- STAYING SANE, LLC, RED BANK, NJ:  
3,939,520, PUB. 1-18-2011. INT. CL. 35.
- STE. MICHELLE WINE ESTATES LTD., WOODINVILLE, WA:  
3,764,071, CANC. INT. CL. 33.
- STECHER, SCOTT, MARBLEHEAD, OH, DBA REEF RUNNER TACKLE COMPANY:  
1,642,909. REN. 3-3-11. INT. CL. 28.
- STEEL, MICHAEL MAYNARD, LA JOLLA, CA:  
2,369,023, CANC. INT. CL. 3.
- STEELTREE INDUSTRIES, INC., LA HABRA, CA:  
2,368,440, CANC. INT. CL. 19.
- STEINBERG, JOSEPHINE, BUTLER, WI:  
3,939,572, PUB. 12-14-2010. INT. CL. 44.  
3,939,573, PUB. 12-14-2010. INT. CL. 44.
- STEINER-OPTIK GMBH, FED REP GERMANY:  
3,939,994, PUB. 1-18-2011. INT. CL. 9.
- STEINHAFELS, INC., WAUKESHA, WI:  
3,942,155, INT. CL. 35.
- STEPAC L.A. LTD., TEFEEN 24959, ISRAEL:  
3,939,512, PUB. 1-18-2011. INT. CL. 9.
- STEPHEN DEANE CROOK, MINNEAPOLIS, MN:  
3,941,101, U.S. CL. B.
- STEPHENS GROUP, INC., MOUNT JULIET, TN, DBA WONDER WORKSHOP:  
2,495,912. REN. 2-26-11. INT. CL. 9.
- STEPTOE AND WIFE ANTIQUES LTD., TORONTO, ONTARIO, CANADA:  
1,149,594. REN. 3-3-11. INT. CL. 6.
- STERLING, PATRICK B., COLFAX, NC:  
3,941,107, INT. CL. 25.
- STETSON, DELIA, MARINA DEL REY, CA:  
2,469,450. REN. 2-26-11. INT. CL. 17.
- STEVE DAMSA, ZEPHYR HILLS, FL:  
3,941,536, INT. CL. 25.
- STEVEN E. ROSEN, DAVIE, FL:  
3,941,760, INT. CL. 25.
- STEVEN VIAT, OAKLAND, CA:  
3,941,697, INT. CL. 30.
- STEVENSON INDUSTRIES, INC., PACIFIC PALISADES, CA:  
2,539,816. REN. 3-3-11. INT. CL. 10.
- STEWART, RACHEL, COLUMBUS, IN:  
2,544,629, CANC. INT. CL. 42.
- STHEART CLOTHING COMPANY LLC, LEONARD, MI:  
3,940,540, PUB. 1-18-2011. INT. CL. 25.
- STICK-AID LLC, LONG BEACH, CA:  
3,942,259, INT. CL. 28.
- STIHLER ELECTRONIC GMBH, STUTTGART, FED REP GERMANY:  
1,636,057. REN. 2-25-11. INT. CL. 10.
- STILL LIFE SKIN, LLC, NEW YORK, NY:  
3,941,657, INT. CL. 3.
- STODDARD, DANIEL, WEBSTER, DALLAS, TX:  
2,865,262, CANC. INT. CL. 39.
- STONE CREEK ENTERTAINMENT INC., RIDGEFIELD, CT:  
3,941,108, INT. CL. 9.
- STORELAW, INC., IRVINE, CA:  
2,865,273, CANC. INT. CL. 9.
- STORSIMPLE, INC., SANTA CLARA, CA:  
3,941,355, MULTIPLE CLASS, INT. CLS. 9 AND 42.
- STOULIL, WILLIAM GREGGORY, PASO ROBLES, CA AND STOULIL, GORDON THOMAS, POULSBORO, WA:  
2,864,674, CANC. INT. CL. 3.
- STRÖCK-BROT GMBH, A-1220 WIEN, AUSTRIA:  
3,882,662, COR. MULTIPLE CLASS, INT. CLS. 16, 30, 35 AND 39.
- STRANGE MUSIC, INC., BLUE SPRINGS, MO:  
3,941,634, INT. CL. 14.
- STRASSBURGER MEATS LLC, CARLSTADT, NJ:  
3,939,752, PUB. 1-18-2011. INT. CL. 35.
- STRATACACHE, INC., DAYTON, OH:  
2,865,401, CANC. INT. CL. 38.
- STRATAGENE, LA JOLLA, CA:  
2,864,647, CANC. INT. CL. 1.
- STRESS LESS, INC., ATLANTA, GA:  
2,466,089. REN. 2-26-11. INT. CL. 5.
- STRICTLY BUSINESS INCORPORATED, ST. LOUIS, MO:  
2,865,135, CANC. INT. CL. 43.
- STRIGNANO FOREX, HALLANDALE BEACH, FL:  
3,939,851, PUB. 1-18-2011. INT. CL. 36.
- STRYKER CORPORATION, KALAMAZOO, MI:  
3,941,541, INT. CL. 10.
- STUART A. LINDER, BEVERLY HILLS, CA:  
3,941,405, INT. CL. 10.
- STUD, INCORPORATED, LOS ANGELES, CA:  
2,367,922, CANC. INT. CL. 42.
- STUDIO IP HOLDINGS LLC, WILMINGTON, DE:  
2,434,124. REN. 2-25-11. INT. CL. 25.
- STUDIOCANAL IMAGE, BOULOGNE-BILLANCOURT, FRANCE:  
2,865,461, CANC. INT. CL. 6.  
2,865,463, CANC. INT. CL. 14.  
2,865,464, CANC. INT. CL. 16.
- STUDIOSML, LLC, FALLS CHURCH, VA:  
3,940,799, PUB. 1-18-2011. INT. CL. 42.
- SU, SHENG SHYOUNG, BROOKLYN, NY:  
2,865,071, CANC. INT. CL. 16.
- SUAU, CARMEN FERNANDEZ, 08011 BARCELONA, SPAIN:  
2,443,750. REN. 2-26-11. INT. CL. 10.
- SUCCESS IN MARKETING, LLC, OCALA, FL:  
3,940,996, MULTIPLE CLASS, INT. CLS. 35 AND 42.
- SUCCESS MARKETING SYSTEMS, INC., FLOWER MOUND, TX:  
2,864,261, CANC. INT. CL. 35.
- SUCCESSION OF ALOIS MAXWELL HIRT, JR., THE, NEW ORLEANS, LA:  
2,472,844, CANC. INT. CL. 41.
- SUDAMERICANA DE FIBRAS S.A., CALLAO, PERU:  
2,476,212. REN. 2-27-11. INT. CL. 22.
- SUE HAMILTON, CAMILLUS, NY:  
3,941,662, INT. CL. 36.
- SUGARLAND LLC, CHAPEL HILL, NC:  
3,939,499, PUB. 1-18-2011. INT. CL. 43.
- SUGARLOAF MOUNTAIN WORKS, INC., GERMANTOWN, MD:  
2,430,019. REN. 2-25-11. INT. CL. 41.
- SUKAITIS, EDVINAS, NANTUCKET, MA:  
3,941,253, INT. CL. 28.
- SUMITOMO CORPORATION, TOKYO, JAPAN, DORAL TIRE & RUBBER CO., INC., STOW, OH:  
905,141. REN. 3-1-11. U.S. CL. 35 (INT. CL. 12).
- SUMITOMO JUKIKAI KOGYO KABUSHIKI KAISHA, TOKYO, JAPAN, AKA SUMITOMO HEAVY INDUSTRIES, LTD.:  
1,149,616. REN. 2-26-11. INT. CL. 7.
- SUMOPTI, PALO ALTO, CA:  
3,941,778, INT. CL. 9.
- SUN CORPORATION, KONAN CITY, ALCHI 483-8555, JAPAN:  
2,958,172. COR. INT. CL. 9.
- SUN DRILLING PRODUCTS CORPORATION, BELLE CHASSE, LA:  
2,864,639, CANC. INT. CL. 1.
- SUN POLAR INTERNATIONAL CO., LTD., CHANGHUA COUNTY, TAIWAN:  
3,941,551, INT. CL. 25.
- SUNBEAM PRODUCTS, INC., BOCA RATON, FL, CHICAGO FLEXIBLE SHAFT COMPANY, CHICAGO, IL:  
281,291. REN. 2-27-11. U.S. CL. 21 (INT. CL. 7).
- SUNBEAM PRODUCTS, INC., BOCA RATON, FL:  
2,438,251. REN. 2-26-11. INT. CL. 37.  
3,941,830, INT. CL. 11.

SUNBELT STEEL TEXAS, LLC, HOUSTON, TX:  
3,941,531, INT. CL. 25.

SUNBURST R&D LIMITED, TORTOLA, BR.VIRGIN ISLANDS:  
2,865,188, CANC. INT. CL. 1.

SUNCOR ENERGY INC., CALGARY, ALBERTA, CANADA:  
3,939,472, PUB. 1-18-2011. MULTIPLE CLASS, INT. CLS. 1 AND 5.  
3,939,473, PUB. 1-18-2011. MULTIPLE CLASS, INT. CLS. 1 AND 5.

SUNDAY AFTERNOONS INC, TALENT, OR:  
3,939,485, PUB. 1-18-2011. INT. CL. 25.

SUNKIST GROWERS, INC., SHERMAN OAKS, CA:  
2,766,672, CANC. INT. CL. 31.  
3,942,284, INT. CL. 31.

SUNNYLAND BULGUR WHEAT INC., FRESNO, CA, DBA SUNNYLAND MILLS:  
2,527,839. REN. 2-26-11. INT. CL. 30.

SUNRISE MEDIA GROUP, INC., MIAMI, FL:  
3,939,822, PUB. 1-18-2011. INT. CL. 32.

SUNRISE TELECOM INCORPORATED, SAN JOSE, CA:  
3,941,565, INT. CL. 9.

SUNSHINE MILLS, INC., RED BAY, AL:  
2,540,313. REN. 2-26-11. INT. CL. 31.

SUNSHINE PET TREATS, INC., RED BAY, AL:  
2,864,329, CANC. INT. CL. 31.

SUNSTAR ENGINEERING INC., OSAKA 569-1134., JAPAN:  
3,939,780, PUB. 1-18-2011. INT. CL. 7.

SUNTERRA CENTRALIZED SERVICES COMPANY, NORTH LAS VEGAS, NV:  
2,369,499, CANC. MULTIPLE CLASS, INT. CLS. 35, 36, 39 AND 42.

SUNTRUST BANKS, INC., ORLANDO, FL:  
2,865,594, CANC. INT. CL. 36.

SUPER BAKERY INC, PITTSBURGH, PA:  
3,941,646, INT. CL. 32.  
3,941,647, INT. CL. 32.

SUPER POWER GOLF COMPANY, LLC, THE, CAMPBELL, CA:  
2,368,637, CANC. INT. CL. 28.

SUPERIOR FINISHES OF AMERICA, LLC, DEL MAR, CA:  
3,941,975, INT. CL. 2.  
3,942,126, INT. CL. 2.

SUPERIOR SERVICE, INC., ST. AUGUSTINE, FL:  
2,865,817, CANC. INT. CL. 37.

SUPERMEDIA LLC, DFW AIRPORT, TX:  
3,941,978, INT. CL. 36.

SUPERPUMPER, INC., MINOT, ND:  
1,611,556. REN. 3-1-11. MULTIPLE CLASS, INT. CLS. 37 AND 42.

SUPPORT OUR TROOPS FOUNDATION, INC., DAYTONA BEACH, FL:  
3,940,954, PUB. 1-18-2011. INT. CL. 36.

SUPREME TAPE, INC., CRANSTON, RI, DBA J.B. PRATA, LTD.:  
2,864,429, CANC. MULTIPLE CLASS, INT. CLS. 16 AND 17.

SURADO SOLUTIONS, INC., RIVERSIDE, CA:  
2,368,186, CANC. MULTIPLE CLASS, INT. CLS. 9 AND 42.

SURESOURCE, INCORPORATED, SHELTON, CT TO SURESOURCE, INCORPORATED, SHELTON, CT:  
2,367,367, CANC. INT. CL. 35.

SURETINT SYSTEMS, LLC, NORTHBROOK, IL:  
3,941,645, INT. CL. 9.

SURGICAL APPLIANCE INDUSTRIES, INC., CINCINNATI, OH:  
929,244. REN. 2-26-11. U.S. CL. 44 (INT. CL. 10).

SURGICAL NOTES MDP, LP, DALLAS, TX:  
3,940,107, PUB. 1-18-2011. MULTIPLE CLASS, INT. CLS. 35 AND 39.

SURYA PHARMACEUTICAL, INC., FREMONT, CA, AKA SURYA PHARMACEUTICAL LIMITED:  
3,939,542, PUB. 1-18-2011. INT. CL. 40.

SUSAN BOYER, PALM SPRINGS, CA:  
3,940,808, PUB. 1-18-2011. INT. CL. 25.

SUSHI SIGLO XXI, S.L., 07730 ALAIOR (MENORCA) ISLAS BALEARES, SPAIN:  
2,827,360, AM. INT. CL. 25.

SUTTER HOME WINERY, INC., ST. HELENA, CA:  
3,941,665, INT. CL. 33.

SUZANNE SOMERSALL, LLC, CHARLOTTESVILLE, VA:  
3,940,599, PUB. 1-18-2011. INT. CL. 14.

SVS HOLLAND B.V., 1600 AA ENKHUIZEN, NETHERLANDS:  
2,865,342, CANC. INT. CL. 31.

SWAIN METER COMPANY, THE, MOUNT PLEASANT, MI:  
2,368,349, CANC. INT. CL. 9.

SWEETS OF OMAN SAOG, SULTANATE OF OMAN, OMAN:  
3,941,949, INT. CL. 30.

SWIMC, INC., NEWARK, DE:  
923,093. REN. 2-26-11. U.S. CL. 16 (INT. CL. 2).

SWIMC, INC., NEWARK, DE, SEAGUARD CORPORATION, PORTSMOUTH, VA:  
1,185,339. REN. 3-2-11. INT. CL. 2.

SWIMC, INC., NEWARK, DE:  
2,452,601. REN. 2-25-11. INT. CL. 8.  
2,476,288. REN. 3-2-11. INT. CL. 16.  
2,483,876. REN. 2-25-11. INT. CL. 2.  
2,502,691. REN. 2-26-11. INT. CL. 2.

SWISHER, CLAUDIA, GORE, VA:  
2,864,509, CANC. INT. CL. 40.

SWITCH COMMUNICATIONS GROUP LLC, LAS VEGAS, NV:  
3,942,079, MULTIPLE CLASS, INT. CLS. 37 AND 42.  
3,942,121, MULTIPLE CLASS, INT. CLS. 42 AND 45.

SWOPE, TRAVIS, BUENA PARK, CA:  
2,864,409, CANC. INT. CL. 25.

SWOYB PROPERTIES, LP, DALLAS, TX:  
3,940,482, PUB. 1-18-2011. INT. CL. 9.  
3,940,483, PUB. 1-18-2011. INT. CL. 16.  
3,940,484, PUB. 1-18-2011. INT. CL. 41.

SYLOGENT LLC, NEWTOWN, PA:  
3,940,593, PUB. 1-18-2011. INT. CL. 42.

SYLVAN R. SHEMITZ DESIGNS, INC., WEST HAVEN, CT:  
2,864,651, CANC. INT. CL. 11.

SYMETIS SA, CH-1012 LAUSANNE, SWITZERLAND:  
3,940,030, PUB. 1-18-2011. MULTIPLE CLASS, INT. CLS. 5, 10 AND 42.

SYMMYS LLC, NEW YORK, NY:  
3,942,467, INT. CL. 41.

SYNOLOGY, INC., TAIPEI, TAIWAN:  
3,941,745, INT. CL. 9.

SYOPTICS NETWORKS, NEW YORK, NY:  
3,940,744, PUB. 1-18-2011. INT. CL. 38.  
3,940,745, PUB. 1-18-2011. INT. CL. 38.  
3,940,757, PUB. 1-18-2011. INT. CL. 38.  
3,940,959, PUB. 1-18-2011. INT. CL. 38.

SYSTREAM, LLC, FREDERICK, MD, DBA SYSTREAM, LLC:  
3,940,841, PUB. 1-18-2011. INT. CL. 9.

SYSTEM ELECTRIC COMPANY, PLANO, TX, AKA MCBRIDE ELECTRIC:  
1,142,882. REN. 3-3-11. INT. CL. 37.

SYSTEMAIR AKTIEBOLAG, SWEDEN:  
3,940,028, PUB. 1-18-2011. INT. CL. 11.

SYSTEMAX INCORPORATED, PORT WASHINGTON, WA:  
1,630,455. REN. 2-26-11. INT. CL. 42.

SYSTEMS BUILDERS ASSOCIATION, INC., WEST MILTON, OH:  
2,633,626, CANC. INT. CL. 41.

SYSTEMS MANUFACTURING CORPORATION, CONKLIN, NY:  
2,864,277, CANC. INT. CL. 20.

SYSTRAN S.A., MONTMORENCY, FRANCE:  
2,429,047. REN. 2-26-11. MULTIPLE CLASS, INT. CLS. 9 AND 38.

SYSTRONIX, INC., SALT LAKE CITY, UT:  
2,367,842, CANC. INT. CL. 9.

S3 PRODUCTS, LLC, PALM BEACH GARDENS, FL:  
2,864,382, CANC. MULTIPLE CLASS, INT. CLS. 17 AND 19.

- T & R SERVICE COMPANY, COLMAN, SD:  
1,671,412. REN. 2-26-11. INT. CL. 42.
- T E TECHNOLOGY, INC., TRAVERSE CITY, MI:  
3,939,420. PUB. 1-18-2011. MULTIPLE CLASS, INT. CLS.  
11 AND 42.
- T.G. AND G.T. WOLF, INC., LITITZ, PA:  
2,865,816. CANC. INT. CL. 35.
- T-MOBILE USA, INC., BELLEVUE, WA:  
3,942,212. INT. CL. 9.
- TA OPERATING LLC, WESTLAKE, OH:  
2,450,381. REN. 3-3-11. INT. CL. 42.
- TA, CHRISTOPHER, WESTMINSTER, CA:  
2,865,645. CANC. INT. CL. 30.
- TABACALERA BRANDS INC, WILMINGTON, DE, BAYUK  
CIGARS INCORPORATED, PHILADELPHIA, PA:  
717,427. REN. 2-25-11. U.S. CL. 17 (INT. CL. 34).
- TACOS LA SILLA, L.L.C., MISSION, TX:  
3,941,488. INT. CL. 43.
- TAIZILONG HOLDING GROUP LIMITED COMPANY,  
ZHEJIANG, CHINA:  
3,940,026. PUB. 1-18-2011. MULTIPLE CLASS, INT. CLS.  
14, 18, 20, 25, 34, 35 AND 43.
- TAKASHI COSMETICS (THAILAND) CO., LTD., SILOM,-  
BANGRAK, BANGKOK, THAILAND:  
3,939,461. PUB. 1-18-2011. MULTIPLE CLASS, INT. CLS.  
3, 16, 41 AND 44.
- TAKEDA PHARMACEUTICAL COMPANY LIMITED, OSA-  
KA, JAPAN:  
2,864,362. CANC. INT. CL. 5.  
2,864,363. CANC. INT. CL. 5.
- TALC DE LUZENAC FRANCE, F-09250 LUZENAC,  
FRANCE:  
3,940,022. PUB. 1-18-2011. MULTIPLE CLASS, INT. CLS. 1  
AND 17.
- TALON ASSET MANAGEMENT, INC., CHICAGO, IL:  
2,864,273. CANC. INT. CL. 36.
- TALUS CORPORATION, PORTLAND, ME:  
2,491,403. REN. 2-28-11. INT. CL. 12.  
2,491,403. CANC. INT. CL. 11.
- TAMARA SCHILLING, GLENDALE, AZ:  
3,941,759. INT. CL. 41.
- TAMMY PARKER, MEMPHIS, TN:  
3,940,558. PUB. 1-18-2011. INT. CL. 3.
- TAMRON CO., LTD., SAITAMA-KEN, JAPAN:  
3,939,649. PUB. 1-18-2011. INT. CL. 9.
- TARA GRINNA SWIMWEAR, INC., CONWAY, SC:  
2,865,442. CANC. INT. CL. 25.
- TARGET BRANDS, INC., MINNEAPOLIS, MN:  
2,864,975. CANC. INT. CL. 35.  
3,942,289. INT. CL. 35.
- TARGETED NUTRIENTS, S.L., SPAIN:  
3,939,989. PUB. 1-18-2011. MULTIPLE CLASS, INT. CLS.  
5, 29 AND 35.
- TARRANT, CORNELIA, NEW YORK, NY:  
2,865,728. CANC. MULTIPLE CLASS, INT. CLS. 28 AND  
30.
- TASCO, WALDORF, MD:  
2,445,403. REN. 2-26-11. INT. CL. 35.
- TATIOSSIAN BROTHERS INC., SUN VALLEY, CA:  
3,940,979. INT. CL. 25.
- TAUNTON PRESS, INC., THE, NEWTOWN, CT:  
1,647,425. REN. 2-26-11. INT. CL. 16.
- TAYLOR & FRANCIS GROUP, LLC, BOCA RATON, FL:  
2,369,338. CANC. INT. CL. 16.
- TAYLOR MADE GOLF COMPANY, INC., CARLSBAD, CA:  
2,865,501. CANC. INT. CL. 28.
- TAYLOR, CARL, RALEIGH, NC:  
3,939,687. PUB. 1-18-2011. INT. CL. 41.
- TCO UTVECKLING, 114 94, STOCKHOLM, SWEDEN:  
2,864,211. CANC. U.S. CL. A.
- TCT MINISTRIES, INC., MARION, IL:  
3,941,439. INT. CL. 38.
- TD BANKNORTH, N.A., PORTLAND, ME:  
2,425,950. CANC. INT. CL. 36.
- TDH MARKETING COMMUNICATIONS, INC., DAYTON,  
OH:  
2,368,840. CANC. INT. CL. 35.
- TEACHERS OF ENGLISH TO SPEAKERS OF OTHER  
LANGUAGES, INC., ALEXANDRIA, VA:  
3,939,691. PUB. 1-18-2011. INT. CL. 41.
- TEAM ONE CREDIT UNION, SAGINAW, MI:  
3,939,767. PUB. 1-18-2011. INT. CL. 40.
- TECH FRIENDS, INC., JONESBORO, AR:  
3,939,568. PUB. 1-18-2011. INT. CL. 9.
- TECHNETIX GROUP LIMITED, BURGESS HILL, UNITED  
KINGDOM:  
3,941,035. INT. CL. 9.
- TECHNICAL EXHIBITS CORPORATION, CHICAGO, IL:  
717,820. REN. 3-1-11. U.S. CL. 21 (INT. CL. 9).
- TECHNOLOGY AND ENTREPRENEURSHIP CENTER OF  
HOUSTON, INC., HOUSTON, TX, DBA HOUSTON TECH-  
NOLOGY CENTER:  
3,942,447. INT. CL. 35.
- TECHNOLOGY PROJECT, PHILADELPHIA, PA:  
2,535,771. CANC. INT. CL. 9.
- TECHNOLOGY SEARCH PARTNERS, L.L.C., HOUSTON,  
TX:  
2,368,267. CANC. INT. CL. 35.
- TECHSOLUTIONS, LLC, ARVADA, CO, DBA LIFEPOINT  
STRATEGIES:  
3,940,162. PUB. 1-18-2011. INT. CL. 35.
- TECHSOLVE, INC., CINCINNATI, OH, TECHSOLVE, INC.,  
CINCINNATI, OH:  
2,490,386. REN. 2-25-11. INT. CL. 42.  
2,495,901. REN. 2-25-11. INT. CL. 9.
- TECHTRONIC FLOOR CARE TECHNOLOGY LIMITED,  
ROAD TOWN, TORTOLA, BR. VIRGIN ISLANDS:  
3,940,507. PUB. 1-18-2011. INT. CL. 7.
- TECHWORLD CORPORATION, LAS VEGAS, NV:  
2,864,074. CANC. INT. CL. 5.
- TECNICA GROUP S.P.A., GIAVERA DEL MONTELLO,  
ITALY, NORDICA S.P.A., MONTEBELLUNA, TREVISO,  
ITALY:  
1,180,293. REN. 3-3-11. INT. CL. 25.
- TECNICA S.P.A., (TREVISO), ITALY:  
3,939,597. PUB. 1-18-2011. INT. CL. 25.
- TED TURNER DOCUMENTARIES, LLC, ATLANTA, GA:  
2,864,218. CANC. INT. CL. 41.
- TEDD CYCLE, INC., NEWBURGH, NY:  
3,940,093. PUB. 1-18-2011. MULTIPLE CLASS, INT. CLS.  
7, 11 AND 12.  
3,940,104. PUB. 1-18-2011. MULTIPLE CLASS, INT. CLS.  
7, 11 AND 12.
- TEEN REACH, SCOTTSDALE, AZ:  
2,863,926. CANC. MULTIPLE CLASS, INT. CLS. 41 AND  
42.
- TEGWAN CYRTODIO, LLC:  
2,421,617. CANC. INT. CL. 9.
- TEKNOR APEX COMPANY, PAWTUCKET, RI:  
3,941,518. INT. CL. 17.
- TELECOMMUNICATION SYSTEMS, INC., ANNAPOLIS,  
MD:  
2,431,278. REN. 2-26-11. INT. CL. 42.
- TELEDYNE MONITOR LABS, INC., ENGLEWOOD, CO:  
2,428,334. REN. 2-28-11. INT. CL. 9.
- TELEDYNE TECHNOLOGIES INCORPORATED, LOS AN-  
GELES, CA:  
1,578,621. CANC. INT. CL. 7.
- TELEFONICA, S.A., MADRID, SPAIN:  
3,939,693. PUB. 1-18-2011. MULTIPLE CLASS, INT. CLS.  
35, 38 AND 42.
- TELEvisa S.A. DE C. V., COLONIA ZEDEC SANTA FE,  
MEXICO:  
3,939,862. PUB. 5-18-2010. INT. CL. 38.
- TELEvisa, S.A. DE C.V., SANTA FE, MEXICO:  
3,940,351. PUB. 1-18-2011. INT. CL. 41.
- TELEVISION EVENTS AND MARKETING, INC., HONOLU-  
LU, HI TO TELEVISION EVENTS AND MARKETING,  
INC., HONOLULU, HI:  
2,528,577. CANC. INT. CL. 32.
- TELFONI, INC., SAFAT, KUWAIT:  
3,941,893. INT. CL. 38.
- TELIFI, LLC, SANTA BARBARA, CA:  
3,940,235. PUB. 1-18-2011. INT. CL. 35.

TELINTEL, WESTON, FL:  
3,941,718, INT. CL. 38.

TELTRONICS, INC., SARASOTA, FL:  
2,367,830, CANC. INT. CL. 9.

TEMPLE UNIVERSITY - OF THE COMMONWEALTH  
SYSTEM OF HIGHER EDUCATION, PHILADELPHIA,  
PA:  
2,512,267, REN. 3-3-11, INT. CL. 41.  
2,512,272, REN. 3-3-11, INT. CL. 41.  
2,512,272, COR. INT. CL. 41.

TEMPLEHOME MEDIA, LLC, LOS ANGELES, CA:  
3,939,745, PUB. 1-18-2011, INT. CL. 35.

TEND SKIN INTERNATIONAL, INC., DAVIE, FL:  
3,939,607, PUB. 1-18-2011, INT. CL. 3.

TENEBRAEX CORPORATION, BOSTON, MA:  
3,940,657, PUB. 1-18-2011, INT. CL. 9.

TENNESSEE VALLEY AUTHORITY, KNOXVILLE, TN:  
2,864,346, CANC. INT. CL. 35.

TENNMAN BRANDS, LLC, NEW YORK, NY:  
3,941,230, INT. CL. 16.

TENSION CLOTHING INC., VANCOUVER, BRITISH CO-  
LUMBIA, CANADA:  
2,906,892, CANC. INT. CL. 25.

TEOBRAS S.R.L., I-00144 ROMA, ITALY:  
3,940,040, PUB. 1-18-2011, MULTIPLE CLASS, INT. CLS.  
3, 9 AND 25.

TEQUILERA MILAGRO, S.A. DE C.V., COL.DESARROLLO  
SANTAFE, MEXICO:  
3,942,393, INT. CL. 33.

TERESITA PEDRAZA, MIAMI, FL:  
3,941,698, INT. CL. 14.

TERMINAL DESIGN, INC., BROOKLYN, NY:  
3,940,447, PUB. 1-18-2011, INT. CL. 9.

TERRAVANT WINE COMPANY, LLC, SANTA BARBARA,  
CA:  
3,942,156, INT. CL. 33.

TERRY HARRIS, CORDOVA, TN:  
3,940,429, PUB. 1-18-2011, INT. CL. 30.

TERU CO., LTD., TOKYO, JAPAN:  
2,463,406, REN. 3-3-11, INT. CL. 16.

TETON OUTFITTERS, L.L.C., RIGBY, ID:  
2,865,106, CANC. INT. CL. 25.

TETRA LAVAL HOLDINGS & FINANCE S.A., CH-1009  
PULLY, SWITZERLAND:  
2,446,618, REN. 3-2-11, INT. CL. 7.

TEUTLOFF, JORN K, SANTA MONICA, CA:  
3,941,033, INT. CL. 25.

TEVA MEATS, LLC, CANISTOTA, SD:  
3,852,522, CANC. IIRN. RESTORED TO S.N. 77-840,695.

TEXAS LAWYERS' INSURANCE EXCHANGE, AUSTIN,  
TX:  
3,942,269, INT. CL. 36.

TEXTILES2, INC., PROVIDENCE, RI:  
2,864,836, CANC. INT. CL. 35.

TEXTRON INNOVATIONS INC., PROVIDENCE, RI:  
1,613,724, REN. 2-26-11, INT. CL. 12.

THAI ORCHID, INC., LAKE OSWEGO, OR:  
2,417,336, REN. 2-25-11, INT. CL. 42.

THANKS FOR HAVING ME GREETING CARD COMPANY,  
LAS VEGAS, NV:  
2,605,406, CANC. INT. CL. 16.

THAYER, CHERYL, CONCORD, CA:  
3,942,436, INT. CL. 35.

THE ALCHEMY SOLUTIONS GROUP, INC., POWDER  
SPRINGS, GA:  
3,941,821, INT. CL. 35.

THE AMERICAN INSTITUTE OF ARCHITECTS, WA-  
SHINGTON, DC:  
3,941,511, INT. CL. 42.

THE ANTIOCH COMPANY, YELLOW SPRINGS, OH:  
2,865,228, CANC. INT. CL. 16.

THE BACHMAN COMPANY, WYOMISSING, PA:  
2,864,530, CANC. INT. CL. 30.

THE BANK OF NEW YORK MELLON, NEW YORK, NY:  
2,380,089, REN. 2-26-11, INT. CL. 36.

THE BANK OF NEW YORK MELLON CORPORATION,  
NEW YORK, NY:  
2,363,731, REN. 2-25-11, INT. CL. 36.

THE BAZAR GROUP, INC., EAST PROVIDENCE, RI,  
DELTAH, INC., E. PROVIDENCE, RI:  
1,635,436, REN. 2-25-11, INT. CL. 14.

THE BOOKSOURCE, INC., ST. LOUIS, MO:  
3,942,304, INT. CL. 28.

THE BUXTON COMPANY, FORT WORTH, TX:  
2,865,660, CANC. INT. CL. 35.

THE BUZAN ORGANISATION LIMITED, MARLOW, BUCK-  
INGHAMSHIRE, UNITED KINGDOM:  
3,939,815, PUB. 1-18-2011, MULTIPLE CLASS, INT. CLS.  
9, 16 AND 41.

THE CABRON FAMILY HOLDINGS, INC., LOS ANGELES,  
CA:  
3,942,074, INT. CL. 32.

THE CANDIE'S FOUNDATION, NEW YORK, NY:  
3,940,119, PUB. 1-18-2011, INT. CL. 41.

THE CARDINAL GROUP INC., TORONTO, ONTARIO,  
CANADA:  
2,864,410, CANC. MULTIPLE CLASS, INT. CLS. 9, 16, 35,  
41 AND 42.

THE CATALYST GROUP, INC., SPRING HOUSE, PA:  
3,942,092, MULTIPLE CLASS, INT. CLS. 35 AND 42.

THE CBORD GROUP, INC., ITHACA, NY:  
3,939,853, PUB. 1-18-2011, INT. CL. 9.

THE CHILDREN'S PROJECT FOUNDATION, SANTA BAR-  
BARA, CA, DBA THE CHILDREN'S PROJECT ACAD-  
EMY:  
3,942,455, INT. CL. 45.

THE CLUB AT ADMIRAL'S COVE, INC., JUPITER, FL:  
2,426,716, REN. 3-2-11, INT. CL. 41.

THE COLLECTOR CAR NETWORK, INC., PHOENIX, AZ:  
3,939,818, PUB. 1-18-2011, INT. CL. 35.

THE COMEDY QUARRY, CHARLOTTE, NC:  
2,865,132, CANC. INT. CL. 41.

THE COMMUNITY FOUNDATION FOR GREATER NEW  
HAVEN, INC., NEW HAVEN, CT:  
3,942,223, INT. CL. 36.

THE CREATIVE CENTER, INC., NEW YORK, NY:  
3,939,839, PUB. 1-18-2011, MULTIPLE CLASS, INT. CLS.  
36 AND 41.

THE CROES OLIVA GROUP, INC., LEXINGTON, MA:  
3,940,622, PUB. 1-18-2011, MULTIPLE CLASS, INT. CLS.  
35 AND 44.

THE DENVER NEWSPAPER AGENCY LLP, DENVER, CO:  
2,864,462, CANC. MULTIPLE CLASS, INT. CLS. 16 AND  
35.

THE DIAL CORPORATION, SCOTTSDALE, AZ:  
3,942,188, INT. CL. 3.

THE DIRECTV GROUP, INC., EL SEGUNDO, CA:  
2,865,216, CANC. INT. CL. 41.

THE ENDURANCE INTERNATIONAL GROUP, INC., BUR-  
LINGTON, MA:  
2,367,849, CANC. INT. CL. 42.

THE EXPRESS CAFE & BAKERY, LLC, SAVANNAH, GA:  
3,941,283, INT. CL. 25.

THE FILLIES, INC., LOUISVILLE, KY:  
3,941,516, INT. CL. 36.

THE GARR GROUP, INC., CHERRY HILL, NJ:  
2,864,672, CANC. INT. CL. 35.

THE GEM GROUP, INC., LAWRENCE, MA:  
3,942,413, INT. CL. 35.

THE GOLDEN PEAR CORPORATION, SOUTHAMPTON,  
NY:  
2,367,719, CANC. INT. CL. 42.

THE GORILLA GLUE COMPANY, CINCINNATI, OH:  
3,940,976, PUB. 10-26-2010, INT. CL. 3.

THE HANDCRAFTED SOAPMAKERS GUILD, INC., SID-  
NEY, OH:  
2,864,199, CANC. MULTIPLE CLASS, INT. CLS. 35 AND  
41.

THE HARTZ MOUNTAIN CORPORATION, SECAUCUS, NJ:  
3,941,786, INT. CL. 31.

THE HAYWIRE GROUP, INC., INDIAN ORCHARD, MA:  
3,942,198, INT. CL. 28.

THE HCF COMPANY, INC., HENDERSON, NV:  
3,860,707, CANC. INT. CL. 5.  
3,860,708, CANC. INT. CL. 5.

- THE HEALTHY EDGE, INC., OMAHA, NE:  
2,430,881. REN. 3-3-11. MULTIPLE CLASS, INT. CLS. 35 AND 42.
- THE HEART EXCHANGE, LLC, BRIARCLIFF MANOR, NY:  
3,941,262, INT. CL. 35.  
3,941,278, INT. CL. 35.
- THE HOBBY HUB, LA MIRADA, CA:  
2,865,078, CANC. INT. CL. 35.
- THE I.D.E.A. CORPORATION, LAS CRUCES, NM:  
2,864,620, CANC. INT. CL. 9.
- THE INFINITY SPORTS GROUP LTD., LANGLEY, B.C., CANADA:  
539,254. REN. 2-26-11. U.S. CL. 39 (INT. CL. 25).
- THE INNOVISION GROUP, L.L.C., ASHEBORO, NC:  
3,941,358, INT. CL. 35.
- THE JIM HENSON COMPANY, INC., LOS ANGELES, CA:  
3,941,091, MULTIPLE CLASS, INT. CLS. 9, 16, 25, 28 AND 41.
- THE JONES GROUP APC, KENNESAW, GA:  
3,940,697, PUB. 1-18-2011. INT. CL. 42.
- THE KANSAS CITY BEANS & GREENS PROGRAM, LLC, KANSAS CITY, MO:  
3,940,308, PUB. 1-18-2011. INT. CL. 35.
- THE KEEP A BREAST FOUNDATION, CARLSBAD, CA:  
3,940,875, PUB. 1-18-2011. INT. CL. 36.  
3,940,876, PUB. 1-18-2011. INT. CL. 41.  
3,940,877, PUB. 1-18-2011. INT. CL. 12.
- THE KEG RIGHTS LIMITED PARTNERSHIP, TORONTO, CANADA, GUILBEAUX, KENNETH J., LAFAYETTE, LA:  
909,366. REN. 2-28-11. U.S. CL. 107 (INT. CL. 41).
- THE KNOT, INC., NEW YORK, NY:  
3,941,775, INT. CL. 9.  
3,942,409, INT. CL. 35.
- THE LEUKEMIA & LYMPHOMA SOCIETY, INC., WHITE PLAINS, NY:  
3,942,084, INT. CL. 36.
- THE LITTLE JOHNNY TRADING COMPANY; PTY LTD, PORT MELBOURNE VIC 3207, AUSTRALIA:  
3,940,021, PUB. 1-18-2011. MULTIPLE CLASS, INT. CLS. 9, 16, 25, 28 AND 41.
- THE LONGABERGER COMPANY, NEWARK, OH:  
3,940,324, PUB. 1-18-2011. INT. CL. 21.
- THE LUBRIZOL CORPORATION, WICKLIFFE, OH:  
2,463,128. REN. 2-25-11. INT. CL. 1.
- THE MARION MILITARY INSTITUTE FOUNDATION, INC., MONTGOMERY, AL:  
3,940,619, PUB. 1-18-2011. INT. CL. 41.
- THE MASTERS OF BEVERAGES, LLC, CORONA, CA:  
3,941,674, INT. CL. 32.
- THE METRAFLEX COMPANY, CHICAGO, IL:  
3,942,352, INT. CL. 6.  
3,942,353, INT. CL. 6.
- THE MICHAEL W. CLARY COMPANY, HUNT VALLEY, MD:  
2,367,599, CANC. INT. CL. 7.
- THE MILLS LIMITED PARTNERSHIP, INDIANAPOLIS, IN:  
3,940,913, PUB. 1-18-2011. INT. CL. 36.
- THE MOTHERVINE, LLC, CHARLOTTE, NC:  
3,941,780, INT. CL. 3.  
3,941,781, INT. CL. 3.
- THE MULTIPLE MYELOMA RESEARCH FOUNDATION, INC., NORWALK, CT:  
3,941,412, MULTIPLE CLASS, INT. CLS. 16, 36, 42 AND 44.
- THE NATIONAL THEATRE FOR CHILDREN, INC., MINNEAPOLIS, MN:  
2,461,489. REN. 2-25-11. INT. CL. 41.
- THE NEW YORK SAYS THANK YOU FOUNDATION, NEW YORK, NY:  
3,940,211, PUB. 1-18-2011. INT. CL. 35.
- THE NEW ZEALAND WAY LIMITED, WELLINGTON, NEW ZEALAND:  
2,864,257, CANC. MULTIPLE CLASS, INT. CLS. 35, 36, 37, 38, 41, 42, 43, 44 AND 45.
- THE OMAR COFFEE COMPANY, NEWINGTON, CT:  
3,940,331, PUB. 1-18-2011. INT. CL. 30.
- THE ORGANIC MATTRESS STORE, INC., HELLERTOWN, PA:  
3,941,193, INT. CL. 35.
- THE ORVIS COMPANY, INC., SUNDERLAND, VT:  
3,942,271, INT. CL. 28.
- THE PETTING ZOO, INC., GLEN BURNIE, MD:  
2,864,544, CANC. INT. CL. 28.
- THE PILLSBURY COMPANY, LLC, MINNEAPOLIS, MN:  
2,476,769, REN. 2-26-11. INT. CL. 30.
- THE PINE STRAW STORE LLC, AUGUSTA, GA:  
3,942,381, INT. CL. 35.
- THE PNC FINANCIAL SERVICES GROUP, INC., PITTSBURGH, PA:  
3,940,971, PUB. 1-18-2011. INT. CL. 36.
- THE PROCTER & GAMBLE COMPANY, CINCINNATI, OH:  
3,941,122, INT. CL. 3.  
3,941,281, INT. CL. 3.  
3,941,860, INT. CL. 29.  
3,942,040, INT. CL. 3.
- THE RABBIT HOLE LIMITED, WOOD END, UNITED KINGDOM:  
3,939,502, PUB. 1-18-2011. MULTIPLE CLASS, INT. CLS. 9, 38 AND 41.
- THE REAL ESTATE LEARNING GROUP, LLC, PORTLAND, ME:  
3,941,882, INT. CL. 41.
- THE REGENTS OF THE UNIVERSITY OF COLORADO, BOULDER, CO:  
3,939,747, PUB. 1-18-2011. MULTIPLE CLASS, INT. CLS. 16, 25 AND 35.
- THE RELEGENCE CORPORATION, NEW YORK, NY:  
2,864,297, CANC. INT. CL. 42.
- THE RETAIL EQUATION, INC., IRVINE, CA:  
2,429,343, REN. 2-26-11. INT. CL. 35.
- THE RIGHT CARD LLC, IRVINE, CA:  
3,941,097, INT. CL. 35.
- THE ROBERT ALLEN GROUP, NEW YORK, NY:  
3,940,630, PUB. 1-18-2011. MULTIPLE CLASS, INT. CLS. 24 AND 35.
- THE ROUND TOWEL COMPANY, INC., NEW YORK, NY:  
2,864,846, CANC. INT. CL. 24.
- THE RUNNING COMPANY, LLC, INDIANAPOLIS, IN:  
3,942,172, MULTIPLE CLASS, INT. CLS. 35 AND 41.
- THE SERVICE DOG INSTITUTE OF SOUTH CAROLINA, SIMPSONVILLE, SC:  
3,942,203, INT. CL. 41.  
3,942,411, INT. CL. 41.
- THE SHOCK BOX LLC, LEWES, DE:  
3,940,732, PUB. 1-18-2011. INT. CL. 35.
- THE STRACKA DESIGN COMPANY, LLC, HOUSTON, TX:  
3,940,523, PUB. 1-18-2011. INT. CL. 41.  
3,940,524, PUB. 1-18-2011. INT. CL. 41.
- THE SUBURBAN BUS DIVISION OF THE REGIONAL TRANSPORTATION AUTHORITY, ARLINGTON HEIGHTS, IL, DBA PACE:  
3,942,297, INT. CL. 39.
- THE TASTEFUL OLIVE, LLC, OVERLAND PARK, KS:  
3,940,673, PUB. 1-18-2011. INT. CL. 35.
- THE TAUBMAN COMPANY LLC, BLOOMFIELD HILLS, MI:  
2,536,618. REN. 2-26-11. INT. CL. 35.
- THE TIFFEN COMPANY, LLC, HAUPPAUGE, NY:  
2,489,623, REN. 2-25-11. INT. CL. 9.  
3,942,283, INT. CL. 9.  
3,942,285, INT. CL. 9.
- THE TRUSTEES OF RESERVATIONS, BEVERLY, MA:  
2,719,729, CANC. INT. CL. 25.
- THE UNLIMITED "INC." WELL, LLC, RENO, NV:  
2,368,093, CANC. MULTIPLE CLASS, INT. CLS. 9 AND 16.
- THE W.E. LONG CO. - INDEPENDENT BAKERS' COOPERATIVE, CHICAGO, IL:  
3,942,131, MULTIPLE CLASS, INT. CLS. 35 AND 41.
- THE WARRANTY GROUP, INC., CHICAGO, IL:  
3,939,717, PUB. 1-18-2011. INT. CL. 36.
- THE WARRELL CLASSIC COMPANY, CAMP HILL, PA:  
1,642,954. REN. 3-2-11. INT. CL. 30.



THE WHITAKER LLC, WILMINGTON, DE, AMP INCORPORATED, HARRISBURG, PA:  
712,448. REN. 2-26-11. U.S. CL. 21 (INT. CL. 9).

THE WINE GROUP LLC, TRACY, CA:  
2,918,027, CANC. INT. CL. 33.  
3,941,423, INT. CL. 33.  
3,942,262, INT. CL. 33.

THE WORLD PROTECTION GROUP, INC., BEVERLY HILLS, CA:  
3,940,462, PUB. 1-18-2011. INT. CL. 45.

THE 10X MANAGEMENT GROUP, LLC, HOUSTON, TX:  
2,864,877, CANC. INT. CL. 36.

THEFIND, INC., MOUNTAIN VIEW, CA:  
3,941,348, INT. CL. 35.

THEOS MEDICAL SYSTEMS INC., SANTA CLARA, CA, DBA MYCHUMMIE.COM:  
3,941,471, INT. CL. 9.

THERA STRAT AG, ALLSCHWIL, SWITZERLAND:  
2,865,607, CANC. INT. CL. 42.

THERMALTAKE TECHNOLOGY CO., LTD., TAIPEI COUNTY, TAIWAN:  
2,475,585. REN. 2-25-11. INT. CL. 9.  
2,479,647. REN. 2-25-11. INT. CL. 9.

THERMAPAK TECHNOLOGIES, INC., PASADENA, CA:  
3,939,517, PUB. 1-18-2011. INT. CL. 9.

THERMO VISION CORPORATION, FRANKLIN, MA:  
2,736,009, CANC. INT. CL. 9.

THERMOGRAPHIC MEASUREMENTS LIMITED, BURTON, SOUTH WIRRAL L64 5TA, UNITED KINGDOM:  
2,502,695. REN. 2-26-11. INT. CL. 9.

THF EQUITIES, LP, WESTCHESTER, IL:  
2,864,426, CANC. INT. CL. 30.  
3,941,297, MULTIPLE CLASS, INT. CLS. 29 AND 30.

THILMANY LLC, KAUKAUNA, WI, MILPRINT, INC., MILWAUKEE, WI, DBA NICOLET PAPER COMPANY:  
903,027. REN. 3-3-11. U.S. CL. 37 (INT. CLS. 16, 26 AND 27).

THINK GLOBAL SCHOOL, INC., SAN FRANCISCO, CA:  
3,941,214, INT. CL. 41.

THINKING GROUP LIMITED, WANCHAI, HONG KONG:  
3,940,319, PUB. 1-18-2011. INT. CL. 9.

THINWARE, INC., MCKINNEY, TX:  
3,940,492, PUB. 1-18-2011. INT. CL. 9.  
3,940,915, PUB. 1-18-2011. INT. CL. 9.

THOMAS A. BRADY SPORTS MEDICINE CENTER, P.C., INDIANAPOLIS, IN:  
3,942,397, MULTIPLE CLASS, INT. CLS. 35, 41 AND 44.

THOMAS III, TERRANCE R., SEATTLE, WA:  
3,941,752, MULTIPLE CLASS, INT. CLS. 9 AND 41.

THOMAS M. STEFFAN, INC., SHOREWOOD, IL, AKA STEFFCO INTERNATIONAL CORPORATION:  
3,940,266, PUB. 1-18-2011. INT. CL. 5.

THOMAS SABO GMBH & CO. SCHMUCKHANDEL KG, D-92104 LAUF/PEGNITZ, FED REP GERMANY:  
2,430,756. REN. 3-3-11. INT. CL. 14.

THOMAS, KENNETH H, MIAMI, FL, DBA K.H. THOMAS ASSOCIATES:  
3,940,147, PUB. 1-18-2011. INT. CL. 35.

THOMPSON HOLDINGS, L.P., NEW YORK, NY:  
2,551,903, CANC. INT. CL. 31.

THOMPSON TANK, INC., DOWNEY, CA:  
3,939,516, PUB. 1-18-2011. MULTIPLE CLASS, INT. CLS. 9, 12, 35, 37, 40 AND 42.

THOMPSON, BUD, WHITTIER, CA:  
3,940,441, PUB. 1-18-2011. MULTIPLE CLASS, INT. CLS. 25 AND 41.

THOMPSON, BUD, WHITTIER, CA, DBA ULTRA ENTERPRISES:  
3,940,572, PUB. 1-18-2011. INT. CL. 5.

THOMPSON, HANCOCK, WITTE & ASSOC., INC., ATLANTA, GA:  
2,369,073, CANC. INT. CL. 42.

THOMPSON, RODNEY B, PHILADELPHIA, PA, DBA FOE COMPANY:  
3,942,340, INT. CL. 25.

THOR POWER CORPORATION, BETHLEHEM, PA:  
3,940,293, PUB. 1-18-2011. INT. CL. 9.

THOR TECH, INC., JACKSON CENTER, OH:  
3,942,282, INT. CL. 12.

THORNTONS INC., LOUISVILLE, KY:  
3,940,651, PUB. 1-18-2011. INT. CL. 35.

THREE DOG BAKERY, INC., KANSAS CITY, MO:  
2,471,083. REN. 3-1-11. INT. CL. 31.

THREE FLOYDS BREWING LLC, MUNSTER, IN:  
3,940,968, PUB. 1-18-2011. INT. CL. 32.

THREE SQUARE, INC., PORTLAND, OR:  
2,864,128, CANC. INT. CL. 43.

THRIVE FOODS LLC, LINDON, UT:  
3,941,572, INT. CL. 29.  
3,941,573, INT. CL. 30.

THULE, INC., SEYMOUR, CT:  
2,367,921, CANC. INT. CL. 12.

THYSSEN INC., DETROIT, MI:  
2,369,113, CANC. MULTIPLE CLASS, INT. CLS. 35 AND 40.

THYSSENKRUPP BAUSERVICE GMBH, HUKKELHOVEN, FED REP GERMANY:  
2,442,345. REN. 2-25-11. INT. CL. 6.

THYSSENKRUPP VDM GMBH, FED REP GERMANY:  
3,939,991, PUB. 1-18-2011. INT. CL. 6.  
3,939,992, PUB. 1-18-2011. INT. CL. 6.

TI GOLF HOLDINGS INC., NEW YORK, NY:  
2,429,568. REN. 2-25-11. INT. CL. 41.

TI-PHARMACEUTICALS, MOUNTAIN VIEW, CA TO ALLERDERM LABORATORIES, INC., PHOENIX, AZ:  
1,146,999, AM. INT. CL. 3.

TIANJIN GALAXY VALVE CO., LTD, TIANJIN, CHINA:  
3,940,682, PUB. 1-18-2011. INT. CL. 17.

TICKETFLY, INC., SAN FRANCISCO, CA:  
3,940,294, PUB. 1-18-2011. INT. CL. 35.

TIDE ACQUISITION CORPORATION, BEVERLY HILLS, CA:  
2,369,607, CANC. INT. CL. 38.

TIDINGS CORPORATION, ARLINGTON, VA:  
2,469,345, CANC. INT. CL. 41.

TIEGE HANLEY LLC, CHICAGO, IL, DBA PURCHASE POINT DESIGN:  
3,942,368, INT. CL. 35.

TIFCO INDUSTRIES, INC., CYPRESS, TX:  
2,368,520, CANC. INT. CL. 6.

TIFFANY (NJ) LLC, PARSIPPANY, NJ, TIFFANY & COMPANY, NEW YORK, NY:  
139,646. REN. 2-26-11. U.S. CL. 28 (INT. CLS. 8 AND 14).

TIGERDIRECT, INC., MIAMI, FL, TIGERSOFTWARE, INC., CORAL GABLES, FL:  
1,641,257. REN. 3-2-11. INT. CL. 16.

TILL; GILBERT J., SEATTLE, WA, DBA URBK ENTERPRISES:  
1,188,237. REN. 3-3-11. INT. CL. 42.

TILLMANN, CAMERON LEE, TEMECULA, CA:  
3,940,872, PUB. 1-18-2011. INT. CL. 25.  
3,940,873, PUB. 1-18-2011. INT. CL. 25.

TIME INC., NEW YORK, NY:  
2,464,490. REN. 3-3-11. INT. CL. 16.  
2,464,987. REN. 3-3-11. INT. CL. 16.

TIME INC. LIFESTYLE GROUP, BIRMINGHAM, AL:  
2,434,844. REN. 3-2-11. INT. CL. 42.  
2,440,291. REN. 2-26-11. INT. CL. 42.

TIME WARNER ENTERTAINMENT COMPANY LP, NEW YORK, NY:  
691,063, CANC. U.S. CL. 107.

TIME WARNER NY CABLE LLC, STAMFORD, CT:  
2,369,036, CANC. INT. CL. 38.

TIMELINE PRODUCTIONS LLC, LINCOLN, NE, DBA READYSTEADY:  
3,942,159, INT. CL. 9.

TIMOTHY J. KIEDROWSKI, AMHERST, OH, DBA KIEDROWSKI'S SIMPLY DELICIOUS BAKERY AND TERESA R. KIEDROWSKI, AMHERST, OH, DBA KIEDROWSKI'S SIMPLY DELICIOUS BAKERY:  
3,940,602, PUB. 1-18-2011. INT. CL. 30.

TIPPMANN SPORTS, LLC, BUFFALO GROVE, IL:  
3,941,129, INT. CL. 28.  
3,942,154, INT. CL. 28.

- TIRE SERVICE EQUIPMENT MFG. CO., INC, PHOENIX, AZ:  
3,940,717, PUB. 1-18-2011. INT. CL. 7.
- TIREWARE, INC., EDENTON, NC:  
3,940,193, PUB. 1-18-2011. INT. CL. 35.
- TISH & SNOOKY'S N.Y.C. INC., LONG ISLAND CITY, NY:  
3,940,825, PUB. 1-18-2011. MULTIPLE CLASS, INT. CLS. 14, 18 AND 25.  
3,940,932, PUB. 1-18-2011. INT. CL. 35.  
3,940,933, PUB. 1-18-2011. INT. CL. 26.  
3,940,934, PUB. 1-18-2011. INT. CL. 25.
- TISHMAN SPEYER PROPERTIES, L.P., NEW YORK, NY:  
2,766,731, CANC. INT. CL. 36.
- TMR WINE COMPANY LLC, ST. HELENA, CA:  
2,469,331, REN. 2-25-11. INT. CL. 33.
- TMW MARKETING COMPANY, INC., FREMONT, CA:  
2,864,720, CANC. MULTIPLE CLASS, INT. CLS. 14, 16 AND 25.
- TNEMEC COMPANY, INC., KANSAS CITY, MO:  
1,636,595, REN. 2-25-11. INT. CL. 2.
- TOB INTERNATIONAL MARKETING CORP., NEW YORK, NY:  
3,458,542, CANC. MULTIPLE CLASS, INT. CLS. 8, 16, 26 AND 28.
- TOBISHI PHARMACEUTICAL CO., LTD., TOKYO, JAPAN:  
2,750,371, CANC. INT. CL. 10.
- TODAY'S WINDOW FASHIONS, INC., FRAZIER PARK, CA:  
2,368,528, CANC. INT. CL. 35.
- TOGETHER FOR OUR MAJORITY POLITICAL ACTION COMMITTEE (TOMPAC), ARLINGTON, VA:  
2,864,381, CANC. INT. CL. 35.
- TOGO'S EATERIES, INC., SAN JOSE, CA:  
2,429,998, REN. 2-25-11. INT. CL. 42.  
2,429,998, CANC. MULTIPLE CLASS, INT. CLS. 29 AND 30.  
2,429,999, REN. 2-25-11. INT. CL. 42.  
2,429,999, CANC. MULTIPLE CLASS, INT. CLS. 29 AND 30.
- TOIV, SHRAGE, BROOKLYN, NY:  
3,939,652, PUB. 1-18-2011. INT. CL. 35.
- TOLKO INDUSTRIES LTD., VERNON, B.C., CANADA:  
2,435,727, REN. 2-26-11. INT. CL. 36.
- TOM TAILOR SPORTSWEAR HANDELSGESELLSCHAFT MBH, 22453 HAMBURG, FED REP GERMANY:  
2,367,526, CANC. INT. CL. 25.
- TOM'S HANDCRAFTED L.L.C., PLAINFIELD, NJ:  
3,940,398, PUB. 1-18-2011. INT. CL. 32.
- TOMPAC LLC, WESTPORT, CT:  
2,865,043, CANC. INT. CL. 18.
- TONY ODISHO EXTENSIONS, INC., CHICAGO, IL:  
3,940,964, PUB. 1-18-2011. INT. CL. 3.
- TOOLS4EVER BV, 3741 GP BAAM, NETHERLANDS:  
2,864,139, CANC. INT. CL. 9.
- TOP FLOOR CREATIONS, INC., NEW CANAAN, CT:  
2,865,699, CANC. INT. CL. 28.
- TOP GRILL IMPORTS, LLC, LINCOLNTON, GA:  
3,940,571, PUB. 1-18-2011. INT. CL. 35.
- TOP OF THE THIRD, INC., LOS ANGELES, CA:  
2,433,996, REN. 2-25-11. MULTIPLE CLASS, INT. CLS. 25, 28 AND 41.
- TOPANGA TECHNOLOGIES, INC., CANOGA, CA:  
3,942,349, MULTIPLE CLASS, INT. CLS. 9 AND 11.
- TORNABENE, DEAN G., MARINA DEL REY, CA:  
2,864,831, CANC. INT. CL. 28.
- TOSH AVIATION, INC., CHATTANOOGA, TN:  
3,941,601, INT. CL. 9.
- TOTAL ALIGNMENT, INC., DALLAS, TX, DBA ALIGNMENT, INC.:  
3,941,962, MULTIPLE CLASS, INT. CLS. 35 AND 41.
- TOTAL EDUCATION SOLUTIONS, INC., SOUTH PASADENA, CA:  
3,939,796, PUB. 1-18-2011. MULTIPLE CLASS, INT. CLS. 16 AND 41.
- TOTH, JAMES JACKSON, NEW YORK, NY:  
2,864,495, CANC. INT. CL. 9.
- TOUR GOLF CLUB, LLC, RICHMOND, VA:  
2,864,379, CANC. INT. CL. 25.
- TOURNAMENT ONE CORP, STAMFORD, CT, AKA T1 GAMING, T1, TOC:  
3,941,777, INT. CL. 9.  
3,941,897, INT. CL. 9.
- TOWN OF ISLIP, ISLIP, NY:  
3,940,557, PUB. 1-18-2011. INT. CL. 39.  
3,940,967, PUB. 1-18-2011. INT. CL. 39.
- TOWNSEND, MARK, BEVERLY HILLS, CA:  
3,940,461, PUB. 1-18-2011. INT. CL. 41.  
3,940,463, PUB. 1-18-2011. INT. CL. 41.
- TOYO BOSEKI KABUSHIKI KAISHA, OSAKA, JAPAN, TA TOYOBO CO., LTD.:  
2,865,061, CANC. INT. CL. 24.
- TOYOTA JIDOSHA KABUSHIKI KAISHA, AICHI-KEN, JAPAN, TA TOYOTA MOTOR CORPORATION:  
2,865,371, CANC. MULTIPLE CLASS, INT. CLS. 7 AND 12.
- TRACFONE WIRELESS, INC., MIAMI, FL:  
2,865,092, CANC. MULTIPLE CLASS, INT. CLS. 9, 35 AND 38.
- TRACY IGWE, CERRITOS, CA, DBA PRETTY AND PRIVILEGED AND LAUREN SANDERS, CERRITOS, CA, DBA PRETTY AND PRIVILEGED:  
3,939,736, PUB. 1-18-2011. INT. CL. 25.
- TRADE DOCK CO., CHEVY CHASE, MD:  
3,940,227, PUB. 1-18-2011. INT. CL. 36.
- TRADITIONAL MEDICINALS, INC., SEBASTOPOL, CA:  
1,671,572, REN. 3-1-11. INT. CL. 5.
- TRAFFIC AND PARKING CONTROL CO., INC, ELM GROVE, WI:  
2,431,992, REN. 2-26-11. INT. CL. 9.
- TRANS WESTERN POLYMERS, INC., LIVERMORE, CA:  
3,941,140, INT. CL. 16.
- TRANS-ASH, INC., CINCINNATI, OH:  
2,205,256, CANC. INT. CL. 19.
- TRANSAMERICA CORPORATION, CEDAR RAPIDS, IA:  
1,635,682, REN. 2-25-11. INT. CL. 36.  
1,635,682, CANC. MULTIPLE CLASS, INT. CLS. 35, 37, 39 AND 41.
- TRANSCONTINENTAL EVENTS, LLC, SEATTLE, WA:  
3,942,438, INT. CL. 35.
- TRANSENTERIX, INC., MORRISVILLE, NC:  
3,941,683, INT. CL. 10.
- TRANSFORMATION ASSOCIATES, INC., LEBANON, NJ, DBA PRECISEPROCESS:  
3,942,238, INT. CL. 9.
- TRANSFORMATION GARDEN, INC., PHOENIX, AZ:  
3,940,844, PUB. 1-18-2011. INT. CL. 45.
- TRANSPLANTS, LLC, SAN DIEGO, CA:  
2,864,950, CANC. INT. CL. 41.
- TRANSPORTATION PROFESSIONAL CERTIFICATION BOARD, INC., WASHINGTON, DC:  
2,430,722, REN. 2-26-11. U.S. CL. B.
- TRANSWESTERN PUBLISHING LLC, SAN DIEGO, CA:  
2,369,545, CANC. INT. CL. 16.
- TRAUMA ENTERTAINMENT LLC, SHERMAN OAKS, CA:  
2,865,553, CANC. INT. CL. 35.
- TRAVEL CORPORATION (INDIA) LTD, MUMBAI-400 021 MAHARASHTRA, INDIA:  
2,865,783, CANC. MULTIPLE CLASS, INT. CLS. 39 AND 43.
- TRAVELPRO INTERNATIONAL, INC., BOCA RATON, FL:  
1,658,250, REN. 3-3-11. INT. CL. 24.  
2,434,023, REN. 2-26-11. INT. CL. 18.
- TRAVELPRO INTERNATIONAL, INC., BOCA RATON, FL, TRAVELPRO INTERNATIONAL, INC., BOCA RATON, FL:  
2,480,772, REN. 2-26-11. INT. CL. 9.
- TRAVELTREX GMBH, FED REP GERMANY:  
3,939,892, PUB. 1-18-2011. INT. CL. 39.
- TREATT PLC, SUFFOLK, UNITED KINGDOM:  
3,939,470, PUB. 1-18-2011. MULTIPLE CLASS, INT. CLS. 1 AND 3.  
3,939,471, PUB. 1-18-2011. MULTIPLE CLASS, INT. CLS. 1 AND 3.
- TREE TRUNK, INC., GARDEN VALLEY, ID:  
2,864,253, CANC. INT. CL. 20.

TRG ACCESSORIES, LLC, ST. LOUIS, MO:  
3,942,077, MULTIPLE CLASS, INT. CLS. 6, 9, 18, 20 AND 21.

TRI COUNTY WATER CONCEPTS, GENEVA, OH:  
2,369,133, CANC. INT. CL. 11.

TRI-COUNTY SUPPLY, INC, CHAFFEE, NY:  
2,726,765, CANC. INT. CL. 35.

TRI-FOCUS WEALTH MANAGEMENT GROUP, INC., CALIFORNIA, CA:  
3,941,222, MULTIPLE CLASS, INT. CLS. 35 AND 36.

TRI-MEX HOLDINGS LIMITED, LONDON W1X 2NL, ENGLAND:  
2,863,976, CANC. MULTIPLE CLASS, INT. CLS. 9, 35, 38 AND 42.

TRI-OAK COMMERCIAL GROUP, INC., CANTON, GA:  
3,939,637, PUB. 8-24-2010. INT. CL. 36.

TRIANGLE TOWN CENTER, LLC, CHATTANOOGA, TN:  
2,538,518. REN. 2-27-11. INT. CL. 37.

TRIBULATION CLOTHING LLC, TUCSON, AZ:  
3,941,421, INT. CL. 25.

TRIBUNE COMPANY, CHICAGO, IL:  
3,940,421, PUB. 1-18-2011. MULTIPLE CLASS, INT. CLS. 16 AND 41.

TRIBUNE PUBLISHING COMPANY, CHICAGO, IL:  
2,864,734, CANC. INT. CL. 35.

TRICAL DE VENEZUELA. S.A., PLAZA VENEZUELA, CARACAS, VENEZUELA:  
2,865,385, CANC. MULTIPLE CLASS, INT. CLS. 19 AND 22.

TRIDEC B.V., NETHERLANDS:  
3,939,941, PUB. 1-18-2011. MULTIPLE CLASS, INT. CLS. 12, 40 AND 42.

TRIDENT SEAFOODS CORPORATION, SEATTLE, WA:  
2,418,631. REN. 3-2-11. INT. CL. 29.

TRILARY, INC., WAUNAKEE, WI:  
2,493,190. REN. 1-18-2011. MULTIPLE CLASS, INT. CLS. 20 AND 21.

TRIOLOGY GLASS & PACKAGING, INC., SANTA ROSA, CA:  
3,940,305, PUB. 12-14-2010. INT. CL. 35.

TRINITY CHRISTIAN CENTER OF SANTA ANA, INC., SANTA ANA, CA:  
2,494,112. REN. 3-3-11. MULTIPLE CLASS, INT. CLS. 16, 25 AND 41.

TRINITY INDUSTRIES, INC., DALLAS, TX:  
2,507,155. REN. 3-3-11. INT. CL. 6.

TRIP ENGINEERING SERVICES, LLC, ARLINGTON, MA:  
2,865,160, CANC. INT. CL. 42.

TRIPLE/S DYNAMICS, INC., DALLAS, TX:  
1,140,234. REN. 3-2-11. INT. CL. 7.

TRISH MCEVOY LTD., NEW YORK, NY:  
2,324,023. REN. 2-25-11. MULTIPLE CLASS, INT. CLS. 3 AND 18.  
3,942,067, INT. CL. 3.

TRISTATE SOLAR, INC., RICHMOND HILL, NY:  
2,864,388, CANC. MULTIPLE CLASS, INT. CLS. 35 AND 37.

TRITON BOATS, LLC, FLIPPIN, AR:  
2,424,581. REN. 2-26-11. INT. CL. 12.

TRIUMPH, LLC, HOPKINS, MN:  
2,434,376. REN. 2-25-11. INT. CL. 12.

TRS QUALITY, INC., FORT WORTH, TX:  
3,941,992, INT. CL. 40.  
3,942,108, INT. CL. 40.

TRS QUALITY, INC., FT. WORTH, TX:  
3,942,407, INT. CL. 11.

TRUCKIN' MOVERS CORPORATION, DURHAM, NC:  
2,332,763, CANC. INT. CL. 9.

TRUCKVAULT, INC., SEDRO WOOLLEY, WA:  
3,942,314, INT. CL. 6.

TRUCKXCHANGE COMPANY, BELLEVUE, WA:  
2,550,979, CANC. INT. CL. 35.

TRUE UNIVERSAL STANDARDS EVERYWHERE, INC., SAN FRANCISCO, CA:  
2,428,135. REN. 2-26-11. U.S. CL. B.

TRUGREEN LIMITED PARTNERSHIP, MEMPHIS, TN:  
3,940,963, PUB. 1-18-2011. INT. CL. 44.

TRUSTED MEDIA NETWORKS, INC., SEATTLE, WA:  
2,864,740, CANC. INT. CL. 9.

TRUSTEES OF DARTMOUTH, HANOVER, NH:  
3,941,322, INT. CL. 41.

TRUSTEES OF THE UNIVERSITY OF PENNSYLVANIA, THE, PHILADELPHIA, PA:  
2,369,442, CANC. MULTIPLE CLASS, INT. CLS. 16, 41 AND 42.

TRUSTWAVE HOLDINGS, INC., CHICAGO, IL:  
3,940,583, PUB. 1-18-2011. INT. CL. 42.  
3,940,883, PUB. 1-18-2011. INT. CL. 42.

TRUTH SPIRITS, LLC, AUSTIN, TX:  
3,941,094, INT. CL. 33.

TRUTZSCHLER GMBH & CO. KG, MONCHENGLADBACH, FED REP GERMANY:  
1,156,993. REN. 2-26-11. MULTIPLE CLASS, INT. CLS. 7, 9 AND 11.

TSA STORES, INC., ENGLEWOOD, CO:  
2,865,103, CANC. INT. CL. 35.

TSAKONAS, ATHENA M., NAPLES, FL, DBA LITE YUMMIES:  
3,942,217, INT. CL. 30.

TSX INC., TORONTO, CANADA:  
3,939,416, PUB. 1-18-2011. INT. CL. 36.

TUCANO SRL, ITALY:  
3,939,960, PUB. 1-18-2011. INT. CL. 18.

TULSA PRO ARENA FOOTBALL, LLC, TULSA, OK, DBA TULSA TALONS:  
3,940,341, PUB. 1-18-2011. MULTIPLE CLASS, INT. CLS. 16, 25 AND 41.

TUPPERWARE PRODUCTS S.A., FRIBOURG CH-1700, SWITZERLAND:  
3,941,224, INT. CL. 3.

TURMAN, GENEVA, RANCHO SANTA MARGARITA, CA:  
3,940,985, INT. CL. 3.

TURN 5, INC., MALVERN, PA:  
3,940,433, PUB. 1-18-2011. INT. CL. 37.

TURNER CORPORATION, THE, NEW YORK, NY:  
2,440,011. REN. 3-2-11. INT. CL. 37.

TURNER MEDIA GROUP, INCORPORATED., DENVER, CO:  
2,864,280, CANC. INT. CL. 41.

TURTLE HOMES CORP., TOPEKA, KS:  
2,864,378, CANC. INT. CL. 42.

TUTKA, LLC, WASILLA, AK:  
3,941,270, INT. CL. 39.

TUTTOESPRESSO S.P.A., ORIGGIO (VARESE), ITALY:  
3,942,065, INT. CL. 30.

TWELVE SOUTH, LLC, MOUNT PLEASANT, SC:  
3,941,370, INT. CL. 20.  
3,941,375, INT. CL. 9.

TWENTIETH CENTURY FOX FILM CORPORATION, LOS ANGELES, CA:  
3,941,888, INT. CL. 9.

TWISTED JOE'S INC, MUSKOGEE, OK:  
2,369,277, CANC. INT. CL. 35.

TWISTED SPOKE, INC., CHICAGO, IL:  
2,428,363. REN. 2-25-11. INT. CL. 42.

TWOMO CORP., SACRAMENTO, CA, DBA LOGIXDATA:  
3,939,523, PUB. 1-18-2011. INT. CL. 35.

TY-CROP INVESTMENTS, LTD., ROSEDALE, BC, CANADA:  
3,940,155, PUB. 1-18-2011. INT. CL. 12.

TYCO FIRE PRODUCTS LP, LANSDALE, PA, ANSUL COMPANY, THE, MARINETTE, WI:  
909,544. REN. 2-28-11. U.S. CL. 26 (INT. CL. 9).

TYCO HEALTHCARE GROUP LP, NEW HAVEN, CT:  
1,641,716. REN. 2-28-11. INT. CL. 10.

TYCO HEALTHCARE GROUP LP, MANSFIELD, MA:  
2,368,716, CANC. INT. CL. 24.

TYNDALE HOUSE PUBLISHERS, INC., CAROL STREAM, IL:  
3,940,509, PUB. 1-18-2011. MULTIPLE CLASS, INT. CLS. 9 AND 41.  
3,940,512, PUB. 1-18-2011. INT. CL. 16.

TYNET BILLING SOLUTIONS, INC, ARLINGTON, TX:  
3,940,224, PUB. 1-18-2011. INT. CL. 42.

TYRONE INJURY & WELLNESS CENTER, LLC., ST. PETERSBURG, FL:  
3,942,083, INT. CL. 44.

- TZVETANOV, MILEN, REGO PARK, NY, DBA ESPRESSO 2.0 LLC:  
3,940,677, PUB. 1-18-2011. INT. CL. 30.
- U.S. BRICK & BLOCK SYSTEMS, INC., DAVIE, FL:  
2,369,540, CANC. INT. CL. 37.
- U.S. DEPARTMENT OF HEALTH AND HUMAN SERVICES, BETHESDA, MD:  
3,941,864, INT. CL. 44.
- U.S. FOODSERVICE, INC., ROSEMONT, IL:  
2,438,587, REN. 2-26-11. INT. CL. 16.  
2,438,588, REN. 2-26-11. INT. CL. 3.  
3,941,505, INT. CL. 16.
- U.S. VISION, INC., GLENDORA, NJ:  
2,368,943, CANC. INT. CL. 9.
- U.S.S. MASSACHUSETTS MEMORIAL COMMITTEE, INC., FALL RIVER, MA:  
3,940,453, PUB. 1-18-2011. INT. CL. 41.
- UBM MEDICA GROUP LLC, JERSEY CITY, NJ:  
2,864,387, CANC. MULTIPLE CLASS, INT. CLS. 16 AND 41.
- UCI MEDICAL CENTER, INC., ORANGE, CA:  
2,864,816, CANC. INT. CL. 44.
- UDELL, MONROE, DANIA BEACH, FL:  
1,149,187, REN. 2-25-11. INT. CL. 42.
- UGA DIGITAL INC., TAIPEI CITY 115, TAIWAN:  
3,941,675, MULTIPLE CLASS, INT. CLS. 9 AND 42.
- ULIKO, INC., BEAVERTON, OR:  
3,940,212, PUB. 1-18-2011. MULTIPLE CLASS, INT. CLS. 35 AND 42.
- ULLMAN, MARILYN, RYE BROOK, NY:  
2,367,826, CANC. INT. CL. 42.
- ULTIMATE BEACH, LTD., GREENFIELD, WI:  
2,525,294, REN. 3-3-11. INT. CL. 42.
- ULTRAFRAME (UK) LIMITED, CLITHEROE, LANCA-SHIRE BB7 1PE, UNITED KINGDOM:  
2,864,314, CANC. INT. CL. 11.
- ULTRAMATICS, INC., OLDSMAR, FL:  
3,940,725, PUB. 1-18-2011. INT. CL. 42.
- ULTRASONIC SERVICES INC., BELLAIRE, TX:  
2,504,972, REN. 2-26-11. INT. CL. 10.
- ULTRATECH, INC., SAN JOSE, CA:  
2,865,344, CANC. INT. CL. 9.
- UMG RECORDINGS, INC., SANTA MONICA, CA:  
3,941,379, INT. CL. 9.
- UMOVEFREE, FLOWER MOUND, TX:  
3,942,377, INT. CL. 36.
- UMS, INC., GREENSBORO, NC:  
2,368,143, CANC. INT. CL. 36.
- UNCOMMON, LLC, CHICAGO, IL:  
3,942,233, INT. CL. 9.
- UNDER ARMOUR, INC., BALTIMORE, MD:  
2,509,632, REN. 3-3-11. INT. CL. 25.
- UNDERHILL, FRANK E. JR., BARBERVILLE, FL:  
2,864,247, CANC. INT. CL. 31.
- UNI-PRESIDENT ENTERPRISES CORP., TAINAN HSIEN, TAIWAN:  
2,864,032, CANC. MULTIPLE CLASS, INT. CLS. 29, 30, 31 AND 32.
- UNICASH FRANCHISING INC., TORONTO, ONTARIO, CANADA:  
2,864,373, CANC. INT. CL. 36.
- UNICHEMA CHEMIE BV, GOUDA, NETHERLANDS:  
2,864,182, CANC. INT. CL. 1.
- UNIFIRST CORPORATION, WILMINGTON, MA:  
2,540,938, REN. 3-2-11. MULTIPLE CLASS, INT. CLS. 9 AND 25.
- UNIHERBS, INC., ARCADIA, CA:  
3,940,486, PUB. 1-18-2011. INT. CL. 5.
- UNION BANK, NATIONAL ASSOCIATION, SAN FRANCISCO, CA:  
2,865,546, CANC. INT. CL. 36.
- UNION CYCLISTE INTERNATIONALE, CH-1860 AIGLE, SWITZERLAND:  
3,939,955, PUB. 1-18-2011. MULTIPLE CLASS, INT. CLS. 12, 25 AND 41.
- UNION LINE, INC., CHICAGO, IL:  
2,441,730, REN. 2-28-11. INT. CL. 25.
- UNION PRIVILEGE, WASHINGTON, DC:  
2,457,526, REN. 3-3-11. INT. CL. 36.
- UNIQEMA AMERICAS LLC, WILMINGTON, DE:  
385,243, REN. 2-26-11. U.S. CL. 6 (INT. CL. 1).
- UNIQUE SYSTEMS, INC., HOLLAND, OH:  
2,865,343, CANC. INT. CL. 9.
- UNISEN, INC., IRVINE, CA:  
2,429,242, REN. 2-25-11. INT. CL. 28.
- UNISOURCE WORLDWIDE, INC., NORCROSS, GA:  
3,797,186, COR. INT. CL. 35.  
3,941,610, INT. CL. 16.
- UNIT CHEMICAL CORPORATION, LOS ANGELES, CA:  
538,938, REN. 2-25-11. U.S. CL. 18 (INT. CL. 5).
- UNITED BUSINESS MEDIA LLC, MANHASSET, NY:  
3,942,009, MULTIPLE CLASS, INT. CLS. 9 AND 38.
- UNITED CUTLERY CORPORATION, THOMASVILLE, GA:  
3,939,644, PUB. 1-18-2011. INT. CL. 8.
- UNITED FEATHER & DOWN, INC., DES PLAINES, IL:  
2,430,066, REN. 3-3-11. INT. CL. 20.  
2,430,067, REN. 3-3-11. INT. CL. 24.  
2,430,068, REN. 3-3-11. INT. CL. 24.
- UNITED INDUSTRIES CORPORATION, ST. LOUIS, MO:  
2,865,530, CANC. INT. CL. 1.
- UNITED INDUSTRIES, INC., STERLING, KS:  
911,204, REN. 3-3-11. U.S. CL. 23 (INT. CL. 7).
- UNITED NATURAL FOODS, INC., PROVIDENCE, RI:  
3,940,100, PUB. 1-18-2011. MULTIPLE CLASS, INT. CLS. 29 AND 30.
- UNITED SERVICE ORGANIZATIONS, INC., WASHINGTON, DC:  
2,865,289, CANC. INT. CL. 41.
- UNITED STATES CRANE, INC., ORLANDO, FL:  
2,368,752, CANC. INT. CL. 42.
- UNITED STATES EQUESTRIAN FEDERATION, INC., LEXINGTON, KY:  
3,939,558, PUB. 1-18-2011. MULTIPLE CLASS, INT. CLS. 35 AND 42.
- UNITED STATES EVENTING ASSOCIATION, LEESBURG, VA:  
3,940,236, PUB. 1-18-2011. MULTIPLE CLASS, INT. CLS. 35 AND 41.
- UNITED STATES FOUNDATION FOR INSPIRATION AND RECOGNITION OF SCIENCE AND TECHNOLOGY, MANCHESTER, NH, AKA US FIRST AND LEGO SYSTEMS, INC, ENFIELD, CT, AKA LEGO CORPORATION CONNECTICUT:  
3,940,508, PUB. 1-18-2011. INT. CL. 41.
- UNITED STATES MINERAL PRODUCTS COMPANY, STANHOPE, NJ, DBA ISOLATEK INTERNATIONAL:  
3,941,120, MULTIPLE CLASS, INT. CLS. 1, 2 AND 17.
- UNITED STATES NAVY, THE, WASHINGTON, DC:  
2,431,314, REN. 3-3-11. MULTIPLE CLASS, INT. CLS. 16 AND 42.
- UNITED STATES POLO ASSOCIATION, LEXINGTON, KY:  
3,939,462, PUB. 1-18-2011. INT. CL. 25.
- UNITED STATES SUBMARINE VETERANS, INC., SILVERDALE, WA:  
2,369,026, CANC. U.S. CL. 200.
- UNITED SYNTEK CORPORATION, DENVER, NC:  
2,368,033, CANC. INT. CL. 9.
- UNIVAR USA INC., REDMOND, WA:  
1,635,885, REN. 3-2-11. INT. CL. 5.
- UNIVERSAL ELECTRONICS INC., CYPRESS, CA:  
3,940,983, INT. CL. 9.
- UNIVERSAL HOSPITAL SERVICES, INC., EDINA, MN:  
3,940,707, PUB. 1-18-2011. MULTIPLE CLASS, INT. CLS. 35, 37 AND 44.  
3,940,726, PUB. 1-18-2011. MULTIPLE CLASS, INT. CLS. 35, 37 AND 44.
- UNIVERSITY OF CINCINNATI, CINCINNATI, OH AND XAVIER UNIVERSITY, CINCINNATI, OH:  
2,431,012, REN. 2-27-11. INT. CL. 41.
- UNIVERSITY OF IDAHO, MOSCOW, ID:  
3,940,396, PUB. 1-18-2011. MULTIPLE CLASS, INT. CLS. 14, 16, 21, 24, 25 AND 41.
- UNIVERSITY OF KANSAS, THE, LAWRENCE, KS:  
2,368,824, CANC. INT. CL. 42.

UNIVITA HEALTH INC., SCOTTSDALE, AZ:  
3,941,710, INT. CL. 44.

UNLOCKING POTENTIAL, INC., BOSTON, MA:  
3,942,078, MULTIPLE CLASS, INT. CLS. 35 AND 41.

UP THE CREEK RESTAURANTS, INC., JOHNS CREEK, GA:  
2,473,741, CANC. INT. CL. 42.

UPRIGHT, INC, SELMA, CA:  
2,368,341, CANC. MULTIPLE CLASS, INT. CLS. 6 AND 7.

URANUS CHEMICALS CO., LTD., HSINCHU HSIEN, TAIWAN:  
3,940,480, PUB. 1-18-2011. INT. CL. 1.

URBAN DECAY COSMETICS LLC, NEWPORT BEACH, CA:  
3,942,273, INT. CL. 3.

URBAN PUBLICATIONS INC, WESLEY CHAPEL, FL:  
3,940,432, PUB. 1-18-2011. INT. CL. 9.

URBANOVSKY, MATT, TAMPA, FL:  
3,941,590, MULTIPLE CLASS, INT. CLS. 16 AND 34.

URENCO LIMITED, BUCKINGHAMSHIRE, UNITED KINGDOM:  
2,864,735, CANC. MULTIPLE CLASS, INT. CLS. 6, 9, 17, 40 AND 42.

US AIRWAYS, INC., TEMPE, AZ:  
2,865,418, CANC. INT. CL. 35.  
3,940,890, PUB. 1-18-2011. INT. CL. 39.  
3,940,948, PUB. 1-18-2011. INT. CL. 28.  
3,941,162, INT. CL. 24.  
3,941,288, INT. CL. 36.

US LEGAL MANAGEMENT SERVICES, INC., LOS ANGELES, CA:  
3,940,525, PUB. 1-18-2011. MULTIPLE CLASS, INT. CLS. 35 AND 42.  
3,940,543, PUB. 1-18-2011. MULTIPLE CLASS, INT. CLS. 35 AND 45.  
3,940,547, PUB. 1-18-2011. MULTIPLE CLASS, INT. CLS. 35 AND 45.

US WEEKLY LLC, NEW YORK, NY:  
2,865,179, CANC. INT. CL. 16.

USAI, LLC, NEW WINDSOR, NY:  
3,941,782, INT. CL. 11.

USER INSIGHT, INC., ATLANTA, GA:  
3,939,538, PUB. 1-18-2011. MULTIPLE CLASS, INT. CLS. 35 AND 42.

USP, LLC, OCEANSIDE, CA:  
3,940,397, PUB. 1-18-2011. INT. CL. 41.

USPDF, LLC, NEW YORK, NY:  
3,940,927, PUB. 1-18-2011. MULTIPLE CLASS, INT. CLS. 35 AND 41.

UTECH PRODUCTS, INC., SCHENECTADY, NY:  
2,673,256, CANC. INT. CL. 9.

UTH FITNESS INC., SELLERSVILLE, PA:  
2,864,281, CANC. INT. CL. 41.

UTICA MUTUAL INSURANCE COMPANY, NEW HARTFORD, NY, DBA UTICA NATIONAL INSURANCE:  
2,865,107, CANC. INT. CL. 36.

UTILITIES INTERNATIONAL, INC., CHICAGO, IL:  
2,473,876, REN. 2-25-11. INT. CL. 9.

UTILITY CONCIERGE, LLC, DALLAS, TX:  
3,939,813, PUB. 1-18-2011. MULTIPLE CLASS, INT. CLS. 35 AND 45.

UVIEW ULTRAVIOLET SYSTEMS INC., MISSISSAUGA, ONTARIO, CANADA:  
3,941,600, INT. CL. 1.

V&S VIN & SPRIT AKTIEBOLAG, STOCKHOLM, SWEDEN:  
2,435,456, REN. 2-28-11. INT. CL. 41.

VAASAN & VAASAN OY, 00440 HELSINKI, FINLAND:  
2,863,929, CANC. MULTIPLE CLASS, INT. CLS. 5, 30 AND 42.

VAC-U-MAX, BELLEVILLE, NJ:  
716,444, REN. 3-3-11. U.S. CL. 23 (INT. CL. 7).

VAC-U-MAX, BELLEVUE, NJ, PULSONICS CORPORATION, LAKEWOOD, NJ:  
1,166,231, REN. 3-3-11. INT. CL. 9.

VACSHACK.COM, INC., OKLAHOMA CITY, OK:  
3,940,800, PUB. 1-18-2011. INT. CL. 35.

VAESTRO, LLC, PORT TOWNSEND, WA:  
3,940,806, PUB. 1-18-2011. INT. CL. 38.

VAF INSTRUMENTS B.V., 3316 EL DORDRECHT, NETHERLANDS:  
2,448,156, REN. 2-26-11. INT. CL. 9.

VAL-ED JOINT VENTURE LLP, MOORHEAD, MN, DBA 702 COMMUNICATIONS:  
3,940,611, PUB. 1-18-2011. INT. CL. 38.

VALENCE HEALTH, INC., CHICAGO, IL:  
2,430,349, REN. 2-25-11. MULTIPLE CLASS, INT. CLS. 35 AND 42.

VALENTINE SUITS, INC., NEW YORK, NY:  
2,865,676, CANC. INT. CL. 25.

VALEX SECURITY, INC., NEW YORK, NY:  
2,581,020, CANC. INT. CL. 39.

VALIDITY SENSORS, INC., SAN JOSE, CA:  
3,941,145, INT. CL. 9.

VALLE STEPHEN K, MARBLEHEAD, MA, VALLE MANAGEMENT ASSOCIATES, INC., LYNN, MA:  
1,659,185, REN. 3-2-11. INT. CL. 42.

VALLEY CHRISTIAN SCHOOLS, INC., SAN JOSE, CA:  
3,941,164, INT. CL. 41.

VALSIR S.P.A., 25078 VESTONE (BRESCIA), ITALY:  
2,864,294, CANC. MULTIPLE CLASS, INT. CLS. 6, 11 AND 17.

VALUE SMART PRODUCTS, INC., SUWANEE, GA:  
2,864,326, CANC. MULTIPLE CLASS, INT. CLS. 3 AND 5.

VAN BEEK GLOBAL/ NINKOV, LLC, ORANGE CITY, IA:  
2,865,374, CANC. INT. CL. 16.

VAN BEEK SCIENTIFIC, L.L.C., ORANGE CITY, IA:  
2,429,898, REN. 2-26-11. INT. CL. 5.

VAN BOMMEL SUPERIOR SHOES B.V., WILLEMSTAD, CURACAO, NETHERLANDS ANTILLES:  
2,863,935, CANC. MULTIPLE CLASS, INT. CLS. 14 AND 18.

VAN ROMPAY, BOUD, CLEARWATER, FL:  
3,941,251, INT. CL. 37.

VANDERBILT UNIVERSITY, THE, NASHVILLE, TN:  
1,634,131, REN. 2-26-11. MULTIPLE CLASS, INT. CLS. 24, 25 AND 41.

VANGUARD GROUP, INC., THE, MALVERN, PA:  
2,431,969, REN. 2-26-11. INT. CL. 36.

VANGUARD TRADEMARK HOLDINGS USA LLC, ST. LOUIS, MO, NATIONAL CAR RENTAL SYSTEM, INC., MINNEAPOLIS, MN:  
1,635,709, REN. 2-25-11. MULTIPLE CLASS, INT. CLS. 37 AND 42.

VANMOOF B.V., NETHERLANDS:  
3,940,031, PUB. 1-18-2011. INT. CL. 12.

VANN'S INC., MISSOULA, MT:  
2,368,540, CANC. INT. CL. 35.

VANTAGEMED CORPORATION, RANCHO CORDOVA, CA:  
2,864,030, CANC. INT. CL. 9.

VAREX SOLUTIONS LLC, GLENDALE, WI:  
3,939,530, PUB. 1-18-2011. INT. CL. 42.

VARIAN SEMICONDUCTOR EQUIPMENT ASSOCIATES, INC., GLOUCESTER, MA:  
2,865,420, CANC. INT. CL. 7.

VARSITY MEDIA GROUP, INC., AUSTIN, TX:  
2,864,528, CANC. INT. CL. 38.

VARSITY SPIRIT CORPORATION, MEMPHIS, TN:  
2,436,010, REN. 2-28-11. INT. CL. 41.

VASCULAR VIEW LLC, SALT LAKE CITY, UT:  
3,942,128, INT. CL. 44.

VASEN INTERNATIONAL LTD, KWUN TONG, KOWLOON, HONG KONG:  
3,941,072, INT. CL. 28.

VBS ONLINE, INC., MILWAUKEE, WI:  
3,942,327, INT. CL. 3.

VECTURA DELIVERY DEVICES LIMITED, CHIPPENHAM, WILTSHIRE, UNITED KINGDOM:  
2,863,995, CANC. MULTIPLE CLASS, INT. CLS. 10 AND 42.

VENEZUELA HUNTINGTON'S DISEASE FAMILY FUND, INC., BOSTON, MA:  
2,368,633, CANC. INT. CL. 9.

- VENTECH, LLC, WIXOM, MI:  
3,941,272, INT. CL. 11.  
3,941,273, INT. CL. 11.  
3,941,274, INT. CL. 11.
- VENTI CORP., LAKE LAND, TN:  
3,941,372, MULTIPLE CLASS, INT. CLS. 30 AND 43.
- VERDI, LLC, BEAR CREEK, WI:  
3,941,784, INT. CL. 29.
- VERICHANNEL, LLC, DILLON, CO:  
3,940,565, PUB. 1-18-2011. INT. CL. 35.
- VERIDIAN HEALTHCARE, LLC, WAUKEGAN, IL:  
3,941,435, INT. CL. 10.
- VERMEER MANUFACTURING COMPANY, PELLA, IA:  
2,542,020. REN. 3-3-11. INT. CL. 7.
- VERSANI SILVER JEWELRY LTD., NEW YORK, NY:  
2,428,219. REN. 2-26-11. INT. CL. 14.
- VERSATRANS, INC., PLYMOUTH, MI:  
3,939,630, PUB. 1-18-2011. INT. CL. 40.
- VESCE, ERNEST D., MT. KISCO, NY:  
3,942,218, INT. CL. 35.
- VEXILAR, INC., MINNEAPOLIS, MN:  
2,432,819. REN. 3-3-11. INT. CL. 9.
- VIACK CORPORATION, TEMPE, AZ:  
2,865,656, CANC. INT. CL. 9.
- VIACOM INTERNATIONAL INC., NEW YORK, NY:  
3,939,707, PUB. 1-18-2011. INT. CL. 38.
- VIALOGY LLC, PASADENA, CA:  
3,941,017, INT. CL. 9.
- VICTORIA BADER PRODUCTIONS, LTD., NEW YORK, NY:  
2,864,551, CANC. INT. CL. 41.
- VICTORIA SPECIALTY FOODS, LLC, BROOKLYN, NY:  
1,149,967. REN. 3-2-11. MULTIPLE CLASS, INT. CLS. 29 AND 30.
- VICTORIA'S SECRET STORES BRAND MANAGEMENT, INC., REYNOLDSBURG, OH:  
2,865,764, CANC. INT. CL. 3.  
3,940,420, PUB. 1-18-2011. INT. CL. 35.
- VICTORINOX SWISS ARMY, INC., MONROE, CT:  
3,941,170, INT. CL. 14.
- VICTORY BREWING COMPANY, DOWNINGTOWN, PA:  
2,751,912, CANC. MULTIPLE CLASS, INT. CLS. 32 AND 43.
- VIDEORATING, S.L., 28004 MADRID, SPAIN:  
2,863,916, CANC. INT. CL. 9.
- VIETNAM MEAT INDUSTRY CORPORATION, HO CHI MINH CITY, VIETNAM, DBA VISSAN IMPORT EXPORT CORPORATION:  
2,865,067, CANC. INT. CL. 29.
- VIETNAM VETERANS MEMORIAL FUND, WASHINGTON, DC:  
3,942,336, MULTIPLE CLASS, INT. CLS. 16, 35, 41 AND 45.
- VIKING DRILL & TOOL, INC., ST. PAUL, MN:  
3,940,607, PUB. 1-18-2011. INT. CL. 7.
- VILLAGE BANK AND TRUST FINANCIAL CORPORATION, MIDLOTHIAN, VA:  
3,940,782, PUB. 1-18-2011. INT. CL. 36.
- VILLAGE LIGHTHOUSE, INC., LOS ANGELES, CA:  
2,368,730, CANC. INT. CL. 3.
- VINCENT VAN GOGH CAFE, LLC, ASTORIA, NY:  
3,941,023, INT. CL. 30.
- VINOS DE LOS HEREDEROS DEL MARQUÉS DE RISCAL, S.A., ELCIEGO, SPAIN:  
3,941,632, INT. CL. 33.
- VINUM CELLARS, SAN FRANCISCO, CA:  
2,524,332, CANC. INT. CL. 33.
- VIRTUAL CORPORATE COACH, INC., CHICAGO, IL:  
2,865,377, CANC. INT. CL. 35.
- VISAGE DEVELOPMENTS LTD., SURREY KT4 7PU, ENGLAND:  
2,863,914, CANC. MULTIPLE CLASS, INT. CLS. 9 AND 42.
- VISCIRA, LLC, SAN FRANCISCO, CA:  
3,939,643, PUB. 1-18-2011. MULTIPLE CLASS, INT. CLS. 35 AND 42.
- VISIOMATIC GMBH, D-70499 STUTTGART, FED REP GERMANY:  
2,864,152, CANC. MULTIPLE CLASS, INT. CLS. 9, 37 AND 42.
- VISION CAPITAL MANAGEMENT CORPORATION, DAVIDSON, NC:  
2,702,334, CANC. INT. CL. 36.
- VISTA TRENDS, INC., SANTA CLARA, CA, DBA EFFETTI:  
2,865,733, CANC. MULTIPLE CLASS, INT. CLS. 35 AND 42.
- VISTABOOKS, SILVERTHORNE, CO:  
2,428,553, REN. 2-26-11. INT. CL. 16.
- VITAMIN RESEARCH PRODUCTS, INC., CARSON CITY, NV:  
2,367,992, CANC. INT. CL. 5.
- VM PRODUCTS & MARKET DEVELOPMENT, INC., SAN JUAN, PUERTO RICO:  
3,942,236, INT. CL. 30.
- VOCADO, LLC, BEVERLY HILLS, CA, FORMERLY VSM SYSTEMS, LLC:  
3,939,620, PUB. 1-18-2011. MULTIPLE CLASS, INT. CLS. 9 AND 42.
- VOCALIS LIMITED, CAMBRIDGE, ENGLAND:  
2,864,000, CANC. MULTIPLE CLASS, INT. CLS. 38 AND 42.
- VODA FASHION LLC, LOS ANGELES, CA, DBA VODA SWIM:  
3,942,213, INT. CL. 25.
- VOITH PAPER PATENT GMBH, HEIDENHEIM, FED REP GERMANY:  
2,864,860, CANC. INT. CL. 7.
- VOLGER, KARL, SANTA MONICA, CA:  
3,939,601, PUB. 1-18-2011. INT. CL. 12.
- VOLKSWAGEN AKTIENGESELLSCHAFT, D-38436 WOLFSBURG, FED REP GERMANY:  
2,864,333, CANC. MULTIPLE CLASS, INT. CLS. 12, 28, 35 AND 37.
- VOLLARA CONCEPTS, LLC, DALLAS, TX:  
3,941,814, INT. CL. 35.  
3,941,815, INT. CL. 35.
- VOLLRATH, EDWARD L., TOMS RIVER, NJ:  
3,941,711, INT. CL. 24.
- VOSS, CAROLYN A., NEVADA CITY, CA:  
2,368,760, CANC. INT. CL. 41.
- VRL INTERNATIONAL LIMITED, GEORGETOWN, CAYMAN ISLANDS:  
2,865,569, CANC. INT. CL. 43.
- VSL PHARMACEUTICALS, INC., GAITHERSBURG, MD:  
2,864,083, CANC. INT. CL. 5.
- VYGON, ECOUEN, FRANCE:  
2,864,959, CANC. INT. CL. 10.  
2,864,974, CANC. INT. CL. 10.
- W & H DEUTSCHLAND GMBH, 83410 LAUFEN, FED REP GERMANY:  
3,940,019, PUB. 1-18-2011. MULTIPLE CLASS, INT. CLS. 7, 9 AND 10.
- W W WOOD, INC., PLEASANTON, TX:  
3,940,199, PUB. 1-18-2011. MULTIPLE CLASS, INT. CLS. 4 AND 21.
- W. D. CORPORATION, BOULDER, CO:  
2,864,344, CANC. INT. CL. 21.
- W. D. CROFT CO., LTD., CORONA, CA:  
2,864,818, CANC. INT. CL. 21.
- W. E. GUNDY & ASSOCIATES, INC., HAILEY, ID:  
3,941,914, INT. CL. 42.
- W. G. PARK, L.P., PHILADELPHIA, PA:  
3,939,825, PUB. 1-18-2011. MULTIPLE CLASS, INT. CLS. 35 AND 36.  
3,939,826, PUB. 1-18-2011. MULTIPLE CLASS, INT. CLS. 35 AND 36.
- W.C. BRADLEY COMPANY, COLUMBUS, GA:  
2,865,487, CANC. INT. CL. 11.
- W.C. BRANHAM, INC., RIVER FALLS, WI:  
3,941,085, INT. CL. 7.  
3,941,086, INT. CL. 7.
- W.J. DEUTSCH & SONS LTD., WHITE PLAINS, NY:  
3,941,690, INT. CL. 33.
- WACHHOLZ & COMPANY, KALISPELL, MT:  
2,865,648, CANC. INT. CL. 35.

WACHOVIA EDUCATION FINANCE INC., RANCHO CORDOVA, CA:  
 2,368,650, CANC. INT. CL. 36.

WAGGONER, WYNDI, OKLAHOMA CITY, OK:  
 3,941,828, INT. CL. 5.

WAGNER, JAMES, MENLO PARK, CA:  
 2,367,595, CANC. INT. CL. 42.

WAH HUNG INTERNATIONAL MACHINERY, INC., MONTEREY PARK, CA:  
 3,942,111, INT. CL. 12.

WAH LUM KUNG FU TEMPLE, INC., ORLANDO, FL:  
 1,676,160, REN. 2-26-11. INT. CL. 41.

WAH YAN HONG CHEMICAL FACTORY LIMITED, TAI HANG TUNG, KOWLOON, HONG KONG:  
 1,629,793, REN. 2-28-11. INT. CL. 5.  
 1,632,122, REN. 2-26-11. INT. CL. 5.

WAHOO TECH, INC., SANTA ANA, CA:  
 2,864,658, CANC. INT. CL. 9.

WAKE FOREST UNIVERSITY, WINSTON-SALEM, NC:  
 3,940,895, PUB. 1-18-2011. INT. CL. 42.  
 3,940,936, PUB. 1-18-2011. INT. CL. 44.

WAL-MART STORES, INC., BENTONVILLE, AR:  
 3,940,220, PUB. 1-18-2011. INT. CL. 35.  
 3,941,793, INT. CL. 33.

WALDE, INC., LA JOLLA, CA, DBA WALDE, INC.:  
 3,940,247, PUB. 1-18-2011. INT. CL. 9.

WALGREEN COMPANY, DEERFIELD, CA:  
 2,369,459, CANC. INT. CL. 5.

WALKER, LESLIE FEASTER, MERION, PA:  
 2,865,019, CANC. INT. CL. 3.

WALLACE, JEFFREY W., BRIDGEVILLE, PA:  
 2,864,252, CANC. INT. CL. 40.

WALLOVER OIL COMPANY INCORPORATED, STRONGSVILLE, OH:  
 3,940,181, PUB. 1-18-2011. MULTIPLE CLASS, INT. CLS. 4 AND 40.

WALLS INDUSTRIES, INC., CLEBURNE, TEXAS, CLEBURNE, TX:  
 3,940,997, INT. CL. 25.  
 3,940,998, INT. CL. 25.  
 3,940,999, INT. CL. 25.

WALSH, MELISSA, ROCHESTER, MI, DBA POWERPLAY COMMUNICATIONS:  
 3,940,479, PUB. 1-18-2011. INT. CL. 41.

WALTER KIDDE PORTABLE EQUIPMENT, INC., MEBANE, NC:  
 2,427,100, REN. 2-26-11. INT. CL. 9.

WALTON, JOHN, A, BATAVIA, IL, DBA JACKPOINT JACKSTANDS:  
 3,942,148, INT. CL. 7.

WANBLI WANAGI, LTD., FRIENDSWOOD, TX:  
 3,941,951, INT. CL. 16.

WARNER BROS. ENTERTAINMENT INC., BURBANK, CA:  
 2,479,341, REN. 2-26-11. INT. CL. 20.  
 2,865,679, CANC. INT. CL. 41.

WARREN, TERRY GRAHAM, FRANKLIN, TN:  
 3,941,319, INT. CL. 28.

WARRICK, MERCEDES, LAS VEGAS, NV:  
 3,941,717, INT. CL. 35.

WARRIOR LACROSSE, INC., WARREN, MI:  
 3,939,866, PUB. 12-26-2006. INT. CL. 25.  
 3,939,867, PUB. 12-26-2006. INT. CL. 25.

WARRIOR SPORTS, INC., WARREN, MI:  
 2,865,263, CANC. INT. CL. 28.  
 2,865,264, CANC. INT. CL. 28.

WASHBURN UNIVERSITY, TOPEKA, KS:  
 3,939,466, PUB. 1-18-2011. MULTIPLE CLASS, INT. CLS. 16, 25 AND 41.

WASKI, JOHN L., WESTPORT, CT, DBA JOHN WASKI DESIGN LLC:  
 3,941,420, MULTIPLE CLASS, INT. CLS. 21 AND 30.

WASTE MANAGEMENT, INC., HOUSTON, TX:  
 3,941,725, INT. CL. 35.

WASTECH INTERNATIONAL, INC., PORTSMOUTH, NH:  
 2,369,161, CANC. INT. CL. 11.

WATCHLINQ, REDONDO BEACH, CA:  
 3,942,096, INT. CL. 14.

WATER LILIES FOOD INC., ASTORIA, NY:  
 3,940,223, PUB. 1-18-2011. MULTIPLE CLASS, INT. CLS. 29 AND 30.

WATER TECH, LLC, EAST BRUNSWICK, NJ:  
 3,941,198, INT. CL. 7.

WATER-JEL TECHNOLOGIES, LLC, CARLSTADT, NJ:  
 3,942,248, MULTIPLE CLASS, INT. CLS. 3 AND 5.

WATERFORD HOME BUILDERS, LLC, HAMILTON, VA:  
 3,940,386, PUB. 1-18-2011. INT. CL. 37.

WATFORD, GLYN, BIRMINGHAM, AL:  
 2,864,234, CANC. INT. CL. 37.

WATSON DIAGNOSTICS, INC., CORONA, CA:  
 2,436,267, REN. 3-2-11. INT. CL. 10.

WAUSAU PAPER MILLS, LLC, WAUSAU, WI:  
 3,941,028, INT. CL. 16.

WAVES AUDIO LTD., TEL AVIV, ISRAEL:  
 3,941,010, INT. CL. 9.

WAXIE'S ENTERPRISES, INC., SAN DIEGO, CA:  
 2,460,456, REN. 2-26-11. MULTIPLE CLASS, INT. CLS. 3, 5 AND 21.

WAYPOINT TECHNOLOGIES, INC., LITTLE FALLS, MN, DBA LAKEMASTER LAKE MAPS:  
 3,940,091, PUB. 1-18-2011. MULTIPLE CLASS, INT. CLS. 9 AND 16.

WEALTH STRONG DEVELOPMENT, INC., LITTLETON, CO:  
 3,942,098, INT. CL. 36.

WEBER HOSTING & DESIGN, MAPLE GROVE, MN:  
 3,942,450, INT. CL. 42.

WEBMAGIC, INC., PASADENA, CA:  
 2,431,010, REN. 2-26-11. MULTIPLE CLASS, INT. CLS. 35, 37, 38, 41 AND 42.

WEBPROLEADS LLC, SAINT PAUL, MN, DBA WEBPROLEADS:  
 3,940,641, PUB. 1-18-2011. INT. CL. 42.

WEBSTER FINANCIAL CORPORATION, WATERBURY, CT:  
 2,865,014, CANC. INT. CL. 36.

WEBTAB, SAN FRANCISCO, CA:  
 3,940,414, PUB. 1-18-2011. MULTIPLE CLASS, INT. CLS. 9 AND 42.

WEB2ZONE, INC., NEW YORK, NY:  
 2,865,173, CANC. INT. CL. 41.

WEDDING BRAND INVESTORS, LLC, SANTA BARBARA, CA, DBA BEVERLY CLARK COLLECTION:  
 2,369,551, CANC. INT. CL. 16.

WEGOLOOK, LLC, OKLAHOMA CITY, OK:  
 3,941,429, INT. CL. 35.

WEIGHT WATCHERS INTERNATIONAL, INC., NEW YORK, NY:  
 3,941,946, INT. CL. 29.  
 3,941,947, INT. CL. 30.  
 3,941,961, INT. CL. 44.  
 3,942,320, INT. CL. 41.

WEIMAN PRODUCTS, LLC, GUMEE, IL:  
 3,939,371, PUB. 1-18-2011. MULTIPLE CLASS, INT. CLS. 3 AND 5.

WEIRICH, DANIEL D., UNALASKA, AK, DBA SEATTITUDE:  
 3,940,530, PUB. 1-18-2011. INT. CL. 41.

WEISBLATT, KRIS, FULTON, NY:  
 3,940,350, PUB. 1-18-2011. INT. CL. 10.

WEISS, ROBIN L, LAGUNA NIGUEL, CA:  
 3,042,607, CANC. INT. CL. 25.

WELBORN BAPTIST FOUNDATION, INC., EVANSVILLE, IN:  
 2,846,143, CANC. INT. CL. 36.

WELLA AKTIENGESELLSCHAFT, FED REP GERMANY:  
 3,940,072, PUB. 1-18-2011. INT. CL. 3.  
 3,940,073, PUB. 1-18-2011. INT. CL. 3.  
 3,940,074, PUB. 1-18-2011. INT. CL. 3.

WELLINGTON'S WORLD LLC, PETALUMA, CA, DBA SETH WELLINGTON:  
 3,941,383, INT. CL. 25.

WELLNESS CONSULTING, INC., PHILADELPHIA, PA:  
 2,864,668, CANC. INT. CL. 41.

WELLPET LLC, TEWKSBURY, MA:  
 3,940,120, PUB. 1-18-2011. INT. CL. 31.

- WELLS FARGO & COMPANY, MINNEAPOLIS, MN:  
2,449,036. REN. 2-26-11. INT. CL. 36.  
2,865,375. CANC. INT. CL. 36.
- WELLS FARGO HOME MORTGAGE, A DIVISION OF  
WELLS FARGO BANK, N.A., DES MOINES, IA:  
1,662,739. REN. 2-25-11. INT. CL. 36.
- WELLS LAMONT INDUSTRY GROUP LLC, NILES, IL:  
3,942,237. INT. CL. 10.
- WELLS' DAIRY, INC., LEMARS, IA:  
2,369,479. CANC. INT. CL. 30.
- WEN, YONGJUN, POMPANO BEACH, FL:  
2,864,815. CANC. INT. CL. 20.
- WEND-EN-EDEN, CAVE CREEK, AZ:  
3,940,600. PUB. 1-18-2011. INT. CL. 41.
- WENGER S.A., DELEMONT, SWITZERLAND:  
3,939,396. PUB. 1-18-2011. INT. CL. 25.
- WENTZ, JOHN BUDD, III, OAKLAND, CA, DBA BUDD  
WENTZ PRODUCTIONS:  
3,940,816. PUB. 1-18-2011. INT. CL. 9.
- WERAS, INC., OZONE PARK, NY:  
3,941,235. INT. CL. 25.
- WERBER, RANA ERIN, LOS ANGELES, CA AND LUSTYAN  
V, JOHN FRANCIS, LOS ANGELES, CA:  
3,940,836. PUB. 1-18-2011. INT. CL. 30.
- WERNER ENTERPRISES, INC., OMAHA, NE:  
1,636,358. REN. 2-26-11. INT. CL. 39.
- WEST GEORGIA NATIONAL BANK, CARROLLTON, GA:  
2,865,532. CANC. INT. CL. 36.
- WEST HONEST INTERNATIONAL INC., CITY OF INDUS-  
TRY, CA:  
2,531,711. CANC. INT. CL. 29.
- WEST, RICHARD L. SNOHOMISH, WA AND RICHMOND,  
VOLNEY IV, BOTHELL, WA:  
2,864,908. CANC. INT. CL. 25.
- WESTERN GAS PARTNERS, LP, THE WOODLANDS, TX:  
3,941,047. INT. CL. 4.
- WESTERN NEW YORK PUBLIC BROADCASTING ASSO-  
CIATION, BUFFALO, NY:  
1,611,594. REN. 3-1-11. INT. CL. 41.
- WESTERN WIRE WORKS, INC., PORTLAND, OR:  
2,430,383. REN. 2-26-11. MULTIPLE CLASS, INT. CLS. 6,  
17 AND 35.
- WESTERN-CULLEN-HAYES, INC., CHICAGO, IL, FEDER-  
AL SIGN AND SIGNAL CORPORATION, CHICAGO, IL:  
907,934. REN. 2-28-11. U.S. CL. 23 (INT. CLS. 6, 7, 8, 9, 11,  
12, 16, 21 AND 28).
- WESTFLEX INDUSTRIAL, INC., NATIONAL CITY, CA:  
2,431,871. REN. 2-25-11. INT. CL. 35.
- WESTIN HOTEL MANAGEMENT, L.P., WHITE PLAINS,  
NY:  
2,925,577. CANC. MULTIPLE CLASS, INT. CLS. 3 AND  
11.
- WESTINGHOUSE ELECTRIC COMPANY LLC, CRANBER-  
RY TOWNSHIP, PA:  
3,941,831. INT. CL. 43.
- WESTOVER CAPITAL ADVISORS, LLC, WILMINGTON,  
DE:  
3,940,467. PUB. 1-18-2011. INT. CL. 36.
- WESTPOINT INTERNATIONAL HATS, SAN FRANCISCO  
DEL RINCON, GTO, MEXICO:  
3,942,215. INT. CL. 25.
- WEVERIJ BULCKAERT N.V., BEVEREN-LEIE, BELGIUM:  
2,864,264. CANC. INT. CL. 27.
- WEXLER PACKAGING PRODUCTS, INC., NORTH WALES,  
PA:  
2,864,480. CANC. INT. CL. 35.
- WGBH EDUCATIONAL FOUNDATION, BOSTON, MA:  
1,159,469. REN. 2-26-11. INT. CL. 41.
- WGI INNOVATIONS, LTD., GRAND PRAIRIE, TX:  
3,941,724. INT. CL. 28.
- WHATABURGER PARTNERSHIP, SAN ANTONIO, TX:  
2,418,380. REN. 2-26-11. INT. CL. 42.  
2,418,394. REN. 2-26-11. INT. CL. 42.
- WHATSAPP INC., SANTA CLARA, CA:  
3,939,463. PUB. 1-18-2011. INT. CL. 42.
- WHEAT DON'T NEED YOU INC., DEER PARK, NY:  
3,940,412. PUB. 1-18-2011. INT. CL. 35.
- WHEELER, BETH S., FORT WAYNE, IN:  
2,524,961. CANC. INT. CL. 16.
- WHEELER, JAMES C., JR., ST. ANN, MO:  
2,863,951. CANC. INT. CL. 41.
- WHEELHOUSE INVESTMENT REAL ESTATE BROKER-  
AGE, INC., SAN FRANCISCO, CA:  
3,939,735. PUB. 1-18-2011. INT. CL. 35.
- WHEELLOCK COLLEGE, BOSTON, MA:  
2,864,127. CANC. MULTIPLE CLASS, INT. CLS. 41 AND  
42.
- WHIRLPOOL PROPERTIES, INC., ST. JOSEPH, MI:  
2,432,036. REN. 3-2-11. INT. CL. 11.
- WHIT, LLC, NEW YORK, NY:  
3,941,761. MULTIPLE CLASS, INT. CLS. 18 AND 25.
- WHITE MOUNTAIN MAPLE WORKS, LLC, LANCASTER,  
NH:  
2,429,400. REN. 2-26-11. INT. CL. 30.
- WHITE SHOE MEDIA, INC., NEW YORK, NY:  
3,942,179. INT. CL. 9.  
3,942,180. INT. CL. 9.
- WHITE, LESTER, ANDREWS, NC:  
3,941,060. INT. CL. 36.
- WHITEPAGES, INC., SEATTLE, WA:  
3,942,222. MULTIPLE CLASS, INT. CLS. 9 AND 35.
- WHITETAIL INSTITUTE OF NORTH AMERICA, INC.,  
PINTLALA, AL:  
2,493,325. REN. 2-28-11. INT. CL. 5.  
2,505,976. REN. 3-1-11. INT. CL. 31.  
2,511,844. REN. 2-28-11. MULTIPLE CLASS, INT. CLS. 5,  
31 AND 35.
- WHITEY'S ICE CREAM , INC., MOLINE, IL:  
3,942,342. INT. CL. 30.
- WHITMORE MANUFACTURING COMPANY, THE, ROCK-  
WALL, TX, INDUSTRIAL-MINE SUPPLY CO., INC., ST.  
LOUIS, MO:  
1,638,835. REN. 3-3-11. INT. CL. 4.
- WHITTLEWALLA, LLC, BELLEVUE, WA:  
3,941,342. INT. CL. 38.
- WHO'S YA DADDY! INC., NORTH PALM BEACH, FL:  
2,407,870. REN. 2-25-11. INT. CL. 25.
- WHOLE FOODS MARKET IP, L.P., AUSTIN, TX:  
3,941,591. MULTIPLE CLASS, INT. CLS. 29 AND 35.
- WHOLE SPACE INDUSTRIES LTD., TAIPEI, TAIWAN:  
3,941,402. INT. CL. 20.
- WHOM HOW LLC, SAN DIEGO, CA:  
2,865,168. CANC. INT. CL. 44.
- WI, INC., ENGLEWOOD, CO:  
3,915,755. COR. INT. CL. 42.
- WICKED BAGGER LLC, LAKE TAPPS, WA:  
3,939,814. PUB. 1-18-2011. INT. CL. 11.
- WIGGINS, D'WAYNE, HAYWARD, CA:  
3,939,586. PUB. 1-18-2011. MULTIPLE CLASS, INT. CLS. 9  
AND 41.
- WIGGLES PTY LIMITED, THE, BONDI JUNCTION, AUS-  
TRALIA:  
2,432,458. REN. 2-26-11. INT. CL. 41.
- WIKUS-SAGENFABRIK WILHELM H. KULLMANN GMBH  
& CO. KG, SPANGENBERG, FED REP GERMANY:  
2,448,918. CANC. MULTIPLE CLASS, INT. CLS. 7 AND 8.
- WILBUR PRODUCTS, INC., SPRING LAKE, MI:  
3,941,306. INT. CL. 3.
- WILBUR-ELLIS COMPANY, SAN FRANCISCO, CA:  
3,941,582. INT. CL. 1.
- WILDER, KING, PASADENA, CA, DBA GIZMO BEACH:  
2,508,074. REN. 3-3-11. INT. CL. 42.
- WILLIAM GRANT & SONS LIMITED, DUFFTOWN,  
BANFFSHIRE, SCOTLAND, UNITED KINGDOM:  
2,432,377. REN. 3-2-11. INT. CL. 33.
- WILLIAM GRANT & SONS MARKETING, LTD, DUBLIN 2,  
IRELAND:  
3,939,817. PUB. 1-18-2011. INT. CL. 33.
- WILLIAMS III, ROBERT K, LAS VEGAS, NV:  
3,940,323. PUB. 1-18-2011. INT. CL. 32.
- WILLIAMS, JOHN ALAN, SANTA FE, NM, DBA WILLIAMS,  
JOHN ALAN:  
3,942,140. INT. CL. 35.
- WILLIAMSON COUNTY TOURISM BUREAU, MARION, IL:  
2,864,982. CANC. INT. CL. 41.



WILLIAMSON-DICKIE MANUFACTURING COMPANY, FORT WORTH, TX:  
3,941,520, INT. CL. 25.

WILLIE GEORGE MINISTRIES, INC., TULSA, OK:  
2,539,674, CANC. MULTIPLE CLASS, INT. CLS. 9, 16, 25, 41 AND 42.  
2,539,675, CANC. MULTIPLE CLASS, INT. CLS. 9, 16, 25, 41 AND 42.

WILSHIRE CLASSIFIEDS, LLC, LOS ANGELES, CA:  
2,548,580, CANC. INT. CL. 16.  
2,593,119, CANC. INT. CL. 16.

WILSON, GRAHAM, LITTLETON, CO:  
2,831,977, CANC. INT. CL. 41.

WINDMOLLER & HOLSCHER, D-49525 LENGERICH, FED REP GERMANY:  
1,638,205, REN. 2-25-11. INT. CL. 9.  
2,437,921, REN. 2-26-11. INT. CL. 7.

WINDOWIZARDS, INC., BRISTOL, PA:  
2,369,327, CANC. INT. CL. 19.

WINDSOR FASHIONS, INC., VERNON, CA:  
2,465,135, REN. 3-1-11. INT. CL. 35.

WINDTRAC LTD., NORTH ANDOVER, MA, DBA WIND-TRAC GPS:  
3,940,395, PUB. 1-18-2011. INT. CL. 9.

WINE HOLDINGS, INC., CHICAGO, IL:  
3,941,636, INT. CL. 35.

WINE SCOUT INTERNATIONAL, NAPA, CA:  
3,941,544, INT. CL. 33.

WINEISIT.COM CORP., AMHERST, NY:  
2,865,373, CANC. INT. CL. 35.

WING HING LUNG LTD., TORONTO, CANADA:  
3,939,871, PUB. 1-18-2011. INT. CL. 30.

WINGBOARD, INC., MINEOLA, NY:  
3,940,905, PUB. 1-18-2011. INT. CL. 28.

WINKS LANE, INC., WILMINGTON, DE:  
3,941,927, INT. CL. 35.

WINNERS INTERNATIONAL RESTAURANTS FRANCHISE SERVICES, INC., FT WALTON BEACH, FL:  
2,691,888, CANC. INT. CL. 42.

WINROCK INTERNATIONAL INSTITUTE FOR AGRICULTURAL DEVELOPMENT, LITTLE ROCK, AR:  
2,367,658, CANC. INT. CL. 35.

WINTEC, INC., CINCINNATI, OH:  
2,368,691, CANC. INT. CL. 42.

WIRELESSBEEHIVE.COM LLC, LAKE POINT, UT, DBA BEEHIVE BROADBAND:  
3,942,278, INT. CL. 38.

WIRELINE TECHNOLOGIES, INC., HOUSTON, TX:  
2,512,749, REN. 3-3-11. INT. CL. 9.

WITHERS LLP, LONDON, UNITED KINGDOM:  
3,939,431, PUB. 1-18-2011. MULTIPLE CLASS, INT. CLS. 35, 36 AND 45.  
3,939,432, PUB. 1-18-2011. MULTIPLE CLASS, INT. CLS. 35, 36 AND 45.

WITHERS, MICHAEL WAYNE, SHAWNEE, KS:  
3,939,669, PUB. 12-14-2010. INT. CL. 35.

WITZ SPORTCASES, INC., GOLD RIVER, CA:  
2,368,681, CANC. INT. CL. 20.

WIZARD WALL, INC., ALEXANDRIA, VA:  
3,940,274, PUB. 1-18-2011. INT. CL. 16.

WIZARDS OF THE COAST LLC, PAWTUCKET, RI:  
3,941,661, INT. CL. 28.

WM. WRIGLEY JR. COMPANY, CHICAGO, IL:  
3,940,774, PUB. 1-18-2011. INT. CL. 30.  
3,941,873, INT. CL. 30.

WMS GAMING INC., WAUKEGAN, IL:  
3,941,871, INT. CL. 9.  
3,941,902, INT. CL. 9.  
3,941,906, INT. CL. 9.  
3,941,908, INT. CL. 9.  
3,941,909, INT. CL. 9.

WOHLFAHRT, ARLAN MICHAEL, LITTLETON, CO, DBA MWOLHF ENTERPRISES:  
2,864,760, CANC. INT. CL. 25.

WOLTERS KLUWER HEALTH, INC., PHILADELPHIA, PA:  
3,940,723, PUB. 1-18-2011. INT. CL. 41.

WOLVERINE WORLD WIDE, INC, ROCKFORD, MI:  
2,367,650, CANC. INT. CL. 25.

WOMEN'S INSTITUTE FOR A SECURE RETIREMENT, WASHINGTON, DC:  
2,430,075, REN. 2-26-11. INT. CL. 41.

WONG, DAVID T., WALNUT, CA:  
3,941,498, INT. CL. 14.

WONG, DOROTHY, ALTADENA, CA:  
3,939,874, PUB. 12-5-2006. INT. CL. 41.

WOOD IRON WOOD FINISHES, INC., NORTHGLENN, CO:  
2,430,963, REN. 2-26-11. MULTIPLE CLASS, INT. CLS. 2 AND 3.

WOOD, MARTIN J., POWAY, CA:  
3,941,790, INT. CL. 9.

WOODROW D. FELIX II, RIVERSIDE, CA:  
2,865,156, CANC. INT. CL. 25.

WOODSTOCK PERCUSSION, INC., SHOKAN, NY:  
2,436,118, REN. 3-2-11. INT. CL. 21.

WOODWORKERS SUPPLY INC., ALBUQUERQUE, NM:  
1,637,203, REN. 2-26-11. INT. CL. 42.

WOOLPERT, INC., DAYTON, OH:  
3,941,034, INT. CL. 9.

WORLD ALCOHOL RACERS, LLC, WEST OLIVE, MI:  
2,865,795, CANC. INT. CL. 41.

WORLD MARATHON MAJORS LLC, WILMINGTON, DE:  
3,942,075, MULTIPLE CLASS, INT. CLS. 25 AND 35.

WORLD ON WHEELS INTERNATIONAL, INC., MARIETTA, GA:  
3,940,368, PUB. 1-18-2011. INT. CL. 35.

WORLD RESIDENT HOLDINGS, LTD., THE, MIRAMAR, FL:  
2,465,902, REN. 3-3-11. INT. CL. 36.  
2,471,805, REN. 3-3-11. INT. CL. 36.

WORLD TRIATHLON CORPORATION, TAMPA, FL:  
3,941,945, INT. CL. 32.

WORLD WIDE LINES, INC., COVINGTON, TN:  
2,434,556, REN. 3-2-11. INT. CL. 21.

WORLD WRESTLING ENTERTAINMENT, INC., STAMFORD, CT:  
2,686,549, CANC. INT. CL. 9.

WORLD WRESTLING ENTERTAINMENT, INC., STAMFORD, CT:  
3,941,046, INT. CL. 41.

WORLDBLABEL HOLDINGS INC, PEEKSKILL, NY, AKA WORLDBLABEL.COM:  
3,942,382, INT. CL. 16.

WORLDWIDE INTERACTIVE NETWORK, INC., KINGSTON, TN:  
3,941,474, MULTIPLE CLASS, INT. CLS. 9 AND 42.

WORLDWIDE PANTS INCORPORATED, LOS ANGELES, CA:  
2,457,243, REN. 3-2-11. INT. CL. 41.

WORLDWIDE RESTAURANT CONCEPTS, INC., SHERMAN OAKS, CA:  
2,865,436, CANC. MULTIPLE CLASS, INT. CLS. 6, 21 AND 25.

WOUND CARE ASSOCIATES, COVINGTON, LA:  
3,941,739, INT. CL. 44.

WP PRODUCTIONS INC., RAY CITY, GA:  
2,369,574, CANC. INT. CL. 42.

WRIGHT WILLIAMS & KELLY, INC., PLEASANTON, CA:  
2,432,933, REN. 2-25-11. INT. CL. 9.  
2,432,934, REN. 3-1-11. INT. CL. 9.

WSTY GROUP, L.L.C., NAPERVILLE, IL:  
2,864,557, CANC. INT. CL. 35.

WU, TAMMIE P., NEW YORK, NY:  
2,865,332, CANC. INT. CL. 11.

X-RITE EUROPE GMBH, CH-8105 REGENSDORF, SWITZERLAND:  
3,939,998, PUB. 1-18-2011. MULTIPLE CLASS, INT. CLS. 9 AND 16.

XANODYNE PHARMACEUTICALS, INC., NEWPORT, KY:  
3,940,185, PUB. 1-18-2011. INT. CL. 5.

XENOCS S.A., SASSENAGE, FRANCE:  
2,864,904, CANC. INT. CL. 7.

XENTRIS WIRELESS, LLC, ADDISON, IL:  
3,940,450, PUB. 1-18-2011. INT. CL. 9.

XEROX CORPORATION, NORWALK, CT:  
2,368,798, CANC. INT. CL. 9.

- XP INNOVATION, LLC, MT. VERNON, IN, DBA DAN'S COMP:  
3,940,083, PUB. 1-18-2011. MULTIPLE CLASS, INT. CLS. 12, 18, 20 AND 25.
- XU YUAN PACKAGING TECHNOLOGY CO., LTD., HSIN-CHU HSIEN, 30352, TAIWAN:  
3,942,151, INT. CL. 7.
- XU, REX FANG, TUSTIN, CA:  
3,940,548, PUB. 1-18-2011. INT. CL. 16.
- XYPEX CHEMICAL CORPORATION, RICHMOND, BC, CANADA:  
3,939,532, PUB. 1-18-2011. MULTIPLE CLASS, INT. CLS. 1 AND 37.
- XYTEX CRYO INTERNATIONAL, LTD., AUGUSTA, GA:  
2,431,505. REN. 3-2-11. INT. CL. 42.
- X10 LTD., HAMILTON HM EX, BERMUDA:  
2,433,264. REN. 3-1-11. INT. CL. 9.
- X20 FILTRATION, ALAMOGORDO, NM:  
3,941,701, INT. CL. 11.
- Y-MED, INC., SAN DIEGO, CA:  
3,940,911, PUB. 1-18-2011. INT. CL. 10.
- YAGO M. JONES, MANHATTAN, NY, AKA YAGO M. JONES:  
3,939,640, PUB. 1-18-2011. INT. CL. 3.
- YAHOO! INC., SUNNYVALE, CA:  
3,941,055, INT. CL. 42.  
3,941,059, INT. CL. 9.
- YAMAHA CORPORATION, HAMAMATSU-SHI, SHIZUOKA-KEN, JAPAN:  
2,440,786. REN. 3-3-11. INT. CL. 15.
- YAMAHA MOTOR CO., LTD., JAPAN:  
3,889,246, COR. MULTIPLE CLASS, INT. CLS. 4, 7 AND 12.
- YARBOROUGH JEWELRY, LLC, NEW YORK, NY:  
3,942,139, MULTIPLE CLASS, INT. CLS. 14 AND 35.
- YASMENA INC., NEW YORK, NY:  
2,864,990, CANC. INT. CL. 18.
- YATVIN, MICHAEL, JEFFERSONVILLE, PA, DBA HEYMO PRODUCTIONS AND HOROWITZ, PAMELA, JEFFERSONVILLE, PA, DBA HEYMO PRODUCTIONS:  
3,939,683, PUB. 1-18-2011. INT. CL. 35.
- YBF LLC, NEW YORK, NY:  
3,942,004, INT. CL. 3.
- YELIYA GROUP CO., SHAN-DONG PROVINCE, POSTAL CODE 261021, CHINA:  
2,428,710. REN. 3-2-11. INT. CL. 25.
- YELLOW STROM; VERWALTUNGSGESELLSCHAFT MBH, KARLSRUHE, FED REP GERMANY:  
3,939,939, PUB. 1-18-2011. MULTIPLE CLASS, INT. CLS. 9, 35, 36, 37, 38 AND 42.
- YELLOW PAGES INTEGRATED MEDIA ASSOCIATION, BERKELEY HTS, NJ:  
2,865,508, CANC. INT. CL. 35.
- YEREVAN BRANDY COMPANY, 375082 YEREVAN, ARMENIA. YEREVAN BRANDY COMPANY, 375082 YEREVAN, ARMENIA:  
2,540,815. REN. 2-27-11. INT. CL. 33.
- YESLENDER, INC., SALT LAKE CITY, UT, DBA LENDER-LAB:  
2,865,295, CANC. INT. CL. 36.
- YGRAINE CONSULTANTS, INC., TORTOLA, BR. VIRGIN ISLANDS:  
2,416,667, CANC. INT. CL. 41.  
2,416,678, CANC. INT. CL. 41.
- YIN TAO, MASON, OH:  
3,941,769, INT. CL. 25.
- YMA MONARCH ACCORDIONS, INC, THORNTON, CO:  
2,437,219. REN. 3-2-11. INT. CL. 15.
- YNGWIE MALMSTEEN, MIAMI, FL AND APRIL MALMSTEEN, MIAMI, FL:  
3,939,557, PUB. 1-18-2011. INT. CL. 25.
- YNOT LLC, VIRGINIA BEACH, VA:  
3,940,631, PUB. 1-18-2011. INT. CL. 43.
- YOCHA DEHE WINTUN NATION, BROOKS, CA:  
3,941,627, INT. CL. 35.
- YOGA HARLEY GIRL LLC, MCKINNEY, TX:  
3,940,337, PUB. 1-18-2011. INT. CL. 41.
- YOGA PEOPLE, INC., BROOKLYN, NY:  
2,368,924, CANC. INT. CL. 41.
- YOGABERRY CORPORATION, JACKSONVILLE, FL:  
3,942,267, MULTIPLE CLASS, INT. CLS. 30 AND 43.
- YONEX KABUSHIKI KAISHA, JAPAN:  
3,940,065, PUB. 1-18-2011. INT. CL. 28.
- YONG LI, COSTA MESA, CA, DBA LUCKY88 ENTERPRISES:  
3,939,746, PUB. 1-18-2011. MULTIPLE CLASS, INT. CLS. 16 AND 41.
- YONWOO CO.,LTD, REPUBLIC OF KOREA:  
3,940,048, PUB. 1-18-2011. INT. CL. 21.
- YORKVILLE ADVISORS, LLC, JERSEY CITY, NJ:  
3,940,793, PUB. 1-18-2011. INT. CL. 36.
- YOUNG, GYVEL Z., WIMBERLEY, TX:  
2,433,538. REN. 2-26-11. INT. CL. 42.
- YOUNGSTOWN STEEL HERITAGE FOUNDATION, YOUNGSTOWN, OH:  
3,940,309, PUB. 1-18-2011. INT. CL. 41.
- YOUNUS, ZESHAAN, ANAHEIM, CA:  
3,940,742, PUB. 1-18-2011. INT. CL. 25.
- YOUSEM, SUSAN, CORTLANDT MANOR, NY:  
2,864,389, CANC. INT. CL. 35.
- YOUTH IN ARTS, SAN RAFAEL, CA:  
2,433,313. REN. 2-26-11. INT. CL. 41.
- YOUTHFRONT, INC., SHAWNEE MISSION, KS:  
2,948,945, AM. MULTIPLE CLASS, INT. CLS. 35 AND 41.
- YOUTHODOLOGY RESEARCH INSTITUTE, LLC, LOS ANGELES, CA:  
3,940,213, PUB. 1-18-2011. MULTIPLE CLASS, INT. CLS. 3 AND 35.
- YUEN, LILLIAN, SEATTLE, WA:  
2,450,355. REN. 3-1-11. INT. CL. 35.
- YUNG SHIN PHARM. IND. CO., LTD., TACHIA TAI-CHUNG, TAIWAN:  
3,941,068, INT. CL. 35.  
3,941,385, INT. CL. 5.
- YUREEKAH, INC., NEW YORK, NY, FORMERLY YUREEKAH LLC:  
3,941,058, INT. CL. 42.
- YZY INC, MIAMI, FL:  
3,942,251, INT. CL. 3.
- Z CIGAR INTERNATIONAL, LLC, GREEN COVE SPRINGS, FL:  
3,940,575, PUB. 1-18-2011. INT. CL. 34.
- ZACHARY EDWARD LEIBOVIT CHILDREN'S TRUST, SEDONA, AZ:  
3,939,551, PUB. 1-18-2011. INT. CL. 36.
- ZACHRY REALTY COMPANY, SAN ANTONIO, TX:  
2,368,926, CANC. INT. CL. 36.
- ZADIK, ALLAN, HOUSTON, TX:  
2,865,757, CANC. INT. CL. 3.
- ZAEGA, INC., BUFFALO, MN:  
3,939,771, PUB. 1-18-2011. INT. CL. 44.
- ZAIO INC., TEMPLE, AZ, AKA ZAIO CORP:  
2,488,300, CANC. INT. CL. 9.
- ZAKOR LLC, TAMPA, FL:  
3,942,332, INT. CL. 1.
- ZECTER, INC., SAN MATEO, CA:  
3,941,167, MULTIPLE CLASS, INT. CLS. 38, 39 AND 42.
- ZEE'S INTERNATIONAL, INC., PHOENIX, AZ:  
2,530,459. REN. 2-26-11. INT. CL. 14.
- ZEEMOTE LLC, SAN FRANCISCO, CA:  
3,942,073, INT. CL. 9.
- ZENAR CORPORATION, OAK CREEK, WI:  
2,450,483. REN. 2-26-11. INT. CL. 7.
- ZENASIS TECHNOLOGIES, INC., CAMPBELL, CA:  
2,865,625, CANC. INT. CL. 9.
- ZENTARIS AG, FRANKFURT, FED REP GERMANY:  
2,864,727, CANC. MULTIPLE CLASS, INT. CLS. 1, 5, 10 AND 42.
- ZEON CORPORATION, TOKYO, JAPAN:  
1,636,152. REN. 2-26-11. INT. CL. 17.
- ZERAH SERVICES, INC., ENGLEWOOD, CO:  
2,864,745, CANC. INT. CL. 35.
- ZERO TRADERS, INC., NEW YORK, NY:  
2,432,112. REN. 2-27-11. INT. CL. 35.

ZERORISK HR, INC., DALLAS, TX:  
2,532,833, REN. 3-3-11. INT. CL. 35.

ZHAO, ZHONG SHI, JIANGSU PROVINCE, CHINA:  
3,941,501, INT. CL. 9.

ZHEJIANG AILISITE HEALTH TECHNOLOGY CO., LTD.,  
JIAXING, ZHEJIANG, CHINA:  
3,939,454, PUB. 1-18-2011. INT. CL. 28.

ZHEJIANG JIAKANG STAINLESS STEEL PRODUCT  
CO.,LTD., ZHEJIANG, CHINA:  
3,940,680, PUB. 1-18-2011. INT. CL. 21.

ZHONG SHAN CAMRY ELECTRONICS CO., LTD., ZHONG-  
SHAN, GUANGDONG, CHINA:  
3,940,629, PUB. 1-18-2011. INT. CL. 9.

ZHONGSHAN SIRUI PHOTOGRAPHIC EQUIPMENT IN-  
DUSTRY CO., LTD., GUANGDONG PROVINCE, CHINA:  
3,940,416, PUB. 1-18-2011. INT. CL. 9.

ZHOU HAI PENG, CHINA:  
3,939,984, PUB. 1-18-2011. INT. CL. 42.

ZIGGY'S CHEESESTEAKS, SOUTHFIELD, MI:  
3,941,967, INT. CL. 43.

ZIRKELBACH CONSTRUCTION, INC., PALMETTO, FL:  
2,431,771, COR. INT. CL. 37.

ZKZ BEST POWER INC., MONTEREY PARK, CA:  
3,940,826, PUB. 1-18-2011. INT. CL. 9.

ZODIAC DATA SYSTEMS, FRANCE:  
3,939,889, PUB. 1-18-2011. INT. CL. 9.

ZOHAR, TIBI, OCEANSIDE, CA:  
3,940,379, PUB. 1-18-2011. INT. CL. 41.

ZOO GAMES, INC., NEW YORK, NY:  
3,942,013, INT. CL. 9.

ZOO MED LABORATORIES, INC., SAN LUIS OBISPO, CA:  
3,940,957, PUB. 1-18-2011. INT. CL. 9.

ZOOM EYEWORKS, INC., BERKELEY, CA:  
3,942,125, INT. CL. 9.

ZUNIGA CHAVEZ, ALVARO JAIME, LOS ANGELES, CA:  
3,940,896, PUB. 1-18-2011. INT. CL. 5.

ZUNZUN EDUCATION SERVICES INC, BLAINE, WA:  
3,940,598, PUB. 1-18-2011. INT. CL. 39.

ZURICH AMERICAN INSURANCE COMPANY, SCHAUM-  
BURG, IL TO ZURICH INSURANCE COMPANY,  
SCHAUMBURG, IL:  
2,547,741, COR. INT. CL. 36.

1C JOINT STOCK VENTURE, MOSCOW, RUSSIAN FED.:  
3,941,051, MULTIPLE CLASS, INT. CLS. 9 AND 16.  
3,941,052, MULTIPLE CLASS, INT. CLS. 9 AND 16.

1ST RESPONSE PUBLIC ADJUSTERS, INC., MIAMI, FL:  
3,940,730, PUB. 1-18-2011. INT. CL. 36.

10 PERCENT SOLUTION, INC., DANA POINT, CA:  
3,940,538, PUB. 1-18-2011. INT. CL. 36.

1099309 ONTARIO LTD, OSHAWA, ONTARIO, CANADA,  
DBA ARMALAC INDUSTRIES:  
3,941,083, MULTIPLE CLASS, INT. CLS. 29 AND 30.

110 PERCENT, INC., GARDEN CITY, MI:  
2,792,572, CANC. INT. CL. 41.

11040 HOLDINGS, INC., IRWIN, PA:  
2,215,990, AM. INT. CL. 6.

1431248 ONTARIO LIMITED, TORONTO, ONTARIO M5X  
1A6, CANADA:  
2,863,959, CANC. MULTIPLE CLASS, INT. CLS. 9, 16  
AND 42.

1776, LTD, SAN ANTONIO, TX:  
2,368,305, CANC. INT. CL. 42.

2SN LLC, KILAUEA, HI:  
3,940,640, PUB. 1-18-2011. INT. CL. 3.

21 DROPS LLC, DELRAY BEACH, FL:  
3,941,842, MULTIPLE CLASS, INT. CLS. 3 AND 35.

21ST CENTURY, PALM BEACH, FL, DBA 21ST CENTURY  
ELOQUENCE:  
2,368,205, CANC. INT. CL. 9.

21ST CENTURY INSURANCE AND FINANCIAL SERVICES  
INC., WILMINGTON, DE:  
2,864,617, CANC. INT. CL. 36.

2135036 ONTARIO LIMITED, NORTH YORK, ONTARIO,  
CANADA:  
3,939,588, PUB. 1-18-2011. INT. CL. 25.

24 HOUR FITNESS USA, INC., SAN RAMON, CA:  
2,395,153, REN. 3-2-11. INT. CL. 42.

3M COMPANY, ST. PAUL, MN:  
1,641,842, REN. 2-28-11. INT. CL. 2.  
2,449,846, REN. 3-1-11. INT. CL. 9.

323.TV LLC, DESOTO, KS:  
3,939,662, PUB. 1-18-2011. MULTIPLE CLASS, INT. CLS.  
35 AND 37.  
3,939,663, PUB. 1-18-2011. MULTIPLE CLASS, INT. CLS.  
35 AND 37.

360 VIANSIA LLC, NAPA, CA:  
2,475,589, REN. 2-26-11. INT. CL. 33.

360SWEATER COMPANY, LLC, SANTA MONICA, CA:  
3,941,613, MULTIPLE CLASS, INT. CLS. 24 AND 25.

3831558 CANDA INC., MONTREAL, QUEBEC, CANADA:  
2,863,887, CANC. INT. CL. 20.

4KIDS ENTERTAINMENT, INC., NEW YORK, NY:  
3,940,945, PUB. 1-18-2011. INT. CL. 41.  
3,941,100, INT. CL. 41.

470858 ALBERTA LTD., EDMONTON, ALBERTA, CANADA,  
DBA LUBE CITY:  
2,516,126, CANC. INT. CL. 37.

6 MINUTES LTD, LONDON, UNITED KINGDOM, DBA LES  
TAI TAI:  
3,940,105, PUB. 1-18-2011. INT. CL. 20.

745 LLC, BOSTON, MA:  
3,940,130, PUB. 1-18-2011. INT. CL. 9.  
3,940,131, PUB. 1-18-2011. MULTIPLE CLASS, INT. CLS. 9  
AND 15.

940 OCEAN DRIVE LLC, MIAMI BEACH, FL:  
3,941,384, INT. CL. 43.

9451 BECKER LANE, LLC, TEMPE, AZ:  
3,941,483, INT. CL. 35.  
3,941,522, INT. CL. 35.

\* \* \* \* \*